

AWARD NUMBER: W81XWH-20-1-0291

TITLE: A Prosthetic Foot Test-Drive Strategy for Improving Stability and Falls-Related Outcomes in Veterans With Leg Amputations

PRINCIPAL INVESTIGATOR: David Morgenroth, MD

CONTRACTING ORGANIZATION: Seattle Institute for Biomedical and Clinical Research
Seattle, WA

REPORT DATE: August 2021

TYPE OF REPORT: Annual

PREPARED FOR: U.S. Army Medical Research and Development Command
Fort Detrick, Maryland 21702-5012

DISTRIBUTION STATEMENT: Approved for Public Release; Distribution Unlimited

The views, opinions and/or findings contained in this report are those of the author(s) and should not be construed as an official Department of the Army position, policy or decision unless so designated by other documentation.

REPORT DOCUMENTATION PAGE

Form Approved
OMB No. 0704-0188

Public reporting burden for this collection of information is estimated to average 1 hour per response, including the time for reviewing instructions, searching existing data sources, gathering and maintaining the data needed, and completing and reviewing this collection of information. Send comments regarding this burden estimate or any other aspect of this collection of information, including suggestions for reducing this burden to Department of Defense, Washington Headquarters Services, Directorate for Information Operations and Reports (0704-0188), 1215 Jefferson Davis Highway, Suite 1204, Arlington, VA 22202-4302. Respondents should be aware that notwithstanding any other provision of law, no person shall be subject to any penalty for failing to comply with a collection of information if it does not display a currently valid OMB control number. **PLEASE DO NOT RETURN YOUR FORM TO THE ABOVE ADDRESS.**

1. REPORT DATE August 2021			2. REPORT TYPE Annual		3. DATES COVERED 01Aug2020 – 31Jul2021	
4. TITLE AND SUBTITLE A Prosthetic Foot Test-Drive Strategy for Improving Stability and Falls-Related Outcomes in Veterans With Leg Amputations					5a. CONTRACT NUMBER W81XWH-20-1-0291	
					5b. GRANT NUMBER	
					5c. PROGRAM ELEMENT NUMBER	
6. AUTHOR(S) David C. Morgenroth, M.D. E-Mail: dmorgen@uw.edu					5d. PROJECT NUMBER	
					5e. TASK NUMBER	
					5f. WORK UNIT NUMBER	
7. PERFORMING ORGANIZATION NAME(S) AND ADDRESS(ES) Seattle Institute for Biomedical and Clinical Research 1660 S. Columbian Way, S-151F Seattle, WA 98108					8. PERFORMING ORGANIZATION REPORT NUMBER MD15-PRSCI-4	
9. SPONSORING / MONITORING AGENCY NAME(S) AND ADDRESS(ES) U.S. Army Medical Research and Materiel Command Fort Detrick, Maryland 21702-5012					10. SPONSOR/MONITOR'S ACRONYM(S)	
12. DISTRIBUTION / AVAILABILITY STATEMENT Approved for Public Release; Distribution Unlimited					11. SPONSOR/MONITOR'S REPORT NUMBER(S)	
13. SUPPLEMENTARY NOTES						
14. ABSTRACT The objective of this project is to assess the effects of prosthetic feet of varying stiffness on dynamic stability and falls-related outcomes in people with transtibial amputation and to determine whether a test-drive strategy using a multi-axial prosthetic foot emulator can be used to predict stability and balance-confidence outcomes. During this reporting period, we have received approval from the VA Central IRB for the human subjects portion of the project. We have also initiated mechanical testing of commercial prosthetic feet that will be used to inform the development of a multi-axial prosthetic foot emulator that will mimic the sagittal and coronal plane mechanical properties of commercial prosthetic feet without physically changing feet. We have also made progress on the hardware and software production of the multi-axial prosthetic foot emulator.						
15. SUBJECT TERMS Lower extremity amputee, transtibial, prosthesis, artificial limb, prosthetic foot, mobility, balance, stability, biomechanics, stiffness, falls, mechanical testing, robotics						
16. SECURITY CLASSIFICATION OF:			17. LIMITATION OF ABSTRACT	18. NUMBER OF PAGES	19a. NAME OF RESPONSIBLE PERSON	
a. REPORT	b. ABSTRACT	c. THIS PAGE			USAMRMC	
Unclassified	Unclassified	Unclassified	Unclassified	28	19b. TELEPHONE NUMBER <i>(include area code)</i>	

TABLE OF CONTENTS

	<u>Page</u>
1. Introduction	4
2. Keywords	4
3. Accomplishments	4
4. Impact	18
5. Changes/Problems	19
6. Products	21
7. Participants & Other Collaborating Organizations	22
8. Special Reporting Requirements	26
9. Appendices	26

1. INTRODUCTION:

The objective of this project is to assess the effects of prosthetic feet of varying stiffness on dynamic stability and falls-related outcomes in people with transtibial amputation and to determine whether a test-drive strategy using a multi-axial prosthetic foot emulator (PFE) can be used to predict stability and balance-confidence outcomes. We have developed a customizable robotic prosthetic foot that mimics the mechanical properties of commercial prosthetic feet without physically changing feet. We will test the ability of the multi-axial emulator to reproduce the experience of wearing the corresponding commercial (actual) prosthetic feet by testing whether brief in-laboratory experiences with feet accurately predict longer-term dynamic stability and balance-confidence outcomes.

2. KEYWORDS:

Lower extremity amputee, transtibial, prosthesis, artificial limb, prosthetic foot, mobility, balance, stability, biomechanics, stiffness, falls, mechanical testing, multi-axial, robotic

3. ACCOMPLISHMENTS:

What were the major goals of the project?

Primary and Secondary and Exploratory Aims (specified in proposal)	Timeline	Description of Tasks Completed	Completion Date or Percent Completion
Obtain and Maintain Human Subjects Approval	Months		
Prepare and submit application to VA Central IRB Modify documents per VA Central IRB feedback	pre-study 0-3 months	<p>We received approval for the initial human subjects protocol application from the VA Central IRB for the Principal Investigator/Study Chair (PISC) application.</p> <p>As required by VA Central IRB, we then submitted the local site applications (LSI) for both data collection sites (Seattle and Minneapolis).</p> <p>The Seattle site LSI application was approved and the Minneapolis site LSI application is pending approval.</p>	<p>PISC: 14-May-2021 (approved)</p> <p>LSIs: 11-August-2021 (Seattle, approval)</p> <p>09-July-2021 (Minneapolis, submission)</p>

Prepare and submit VA Puget Sound Research and Development (R&D) Application for Human Subjects Research		<p>We received approval for the non-human subjects portion of the project that occurs at the Seattle site only (i.e., prosthetic foot mechanical testing to program the multiaxial PFE) from the VA Puget Sound R&D. Continuing review approval for this non-human subjects portion of the project was also received.</p> <p>We also received VA Puget Sound R&D approval for the human subjects portion of the work (PISC) and the local Seattle site (LSI).</p>	<p>Non-human subjects: 24-Sep-2020 (initial approval); 05-Aug-2021 (Continuing Review Approval)</p> <p>Human subjects PISC: 27-May-2021 (approval)</p> <p>Human subjects LSI Seattle: 26-Aug-2021 (approval)</p>
Prepare and submit HRPO Protocol for Human Subjects Research	4-6	We submitted the PISC application to HRPO for required second level review and have responded to the queries they sent in response.	HRPO: 15-July-2021 (submitted)
Modify per ORP/HRPO feedback	6-8		
Study Preparation	Months		
Prepare and finalize study protocol and consent materials (e.g., recruitment materials, consent forms)	pre-study	We have prepared, finalized, and received approval for study protocol and consent materials (i.e., telephone script, approach letter, talking points, and flyers) from the VA Central IRB.	29-Jan-2021
Prepare data collection files (e.g., forms, surveys)	1-5	We have developed data collection files including forms and surveys for each of the six study visits.	30-Nov-2020
Create recruitment and data collection databases	1-5	We have created and received approval for the recruitment and data collection databases from the VA Central IRB.	29-Jan-2021
Purchase research supplies and equipment (e.g., prosthetic feet, treadmill, laptops, software)	1-3	We have purchased a study laptop, study prosthetic feet, and a custom Europa+ prosthetic pyramid-embedded load cell for robotic foot emulator design and testing to prepare equipment for human subjects data collection.	Ongoing
Mechanical testing of commercial prosthetic feet and input of mechanical testing data to multiaxial	1-9	After facing substantial COVID-related delays, we have now initiated mechanical testing of commercial prosthetic feet including designing, fabricating, and assembling marker clusters, the motion capture camera system and supporting hardware.	10%
Delivery of emulator and training investigators and staff for use	6-8	Required agreements are in place with Humotech for the VA collaboration and purchase of Seattle's prosthetic foot emulator.	Ongoing
In-person kick-off meeting	8-9	Held virtual kick-off meeting with entire investigative team (virtual instead of in-person due to pandemic).	30-Oct-2020
Train research staff	1-9	Elizabeth Halsne and Talia Ruxin have undergone training including	Ongoing

		biomechanical data collection, human subjects research, and mechanical testing of prosthetic feet training.	
Register of clinical trial on clinicaltrials.gov	8	Will not begin until full human subjects approvals are in place.	
Ongoing Study Coordination	Months		
Once per month teleconference meetings of investigative team	1-36	Recurrent meetings to discuss human subjects approval submission process, mechanical testing, and biomechanical data collection protocol.	Ongoing
Participant Recruitment	9-45	The human subjects protocol is awaiting approval by the VA local site in Minneapolis (LSI) and by HRPO.	Not yet begun
Data Collection	9-45	The human subjects protocol is awaiting approval by the VA local site in Minneapolis (LSI) and by HRPO.	Not yet begun
Data Analysis	9-45	The human subjects protocol is awaiting approval by the VA local site in Minneapolis (LSI) and by HRPO.	Not yet begun
Dissemination	9-48	The human subjects protocol is awaiting approval by the VA local site in Minneapolis (LSI) and by HRPO.	Not yet begun

What was accomplished under these goals?

During this reporting period, the VA Central IRB Principal Investigator/Study Chair (PISC) human subjects testing application was approved. Specifically, we received approval for all study documents, including consent forms, recruitment materials (telephone script, talking points, approach letter, and flyers), data collection forms (self-report questionnaire packets and study visit forms for each data collection session), and recruitment and data collection databases. VA REDCap Project Setup and Online Designer were used to enter the self-report questionnaire questions for future data collection (**Appendix 1**). Designated study staff will use VA REDCap to enter de-identified self-report questionnaire responses. We finalized the study methodology and outcome measures (e.g., including discussions with MVAHCS data collection site to ensure feasibility of matching methodology across sites) as part of the finalized study protocol approved by the VA Central IRB.

Once we received approval from the VA Central IRB for the PISC application, we submitted site-specific Local Site Investigator (LSI) applications to the VA Central IRB. Approval for the Seattle site application was received while the Minneapolis site LSI is pending approval.

Additionally, we submitted the human subjects PISC protocol application for second-level review by HRPO, which is pending approval.

We also received local VA Puget Sound R&D Committee approval for the non-human subjects portion of work to characterize the mechanical properties of commercial prosthetic feet in the sagittal and coronal planes for input to the multiaxial prosthetic foot emulator. A continuing review for this work was also approved. These steps are critical to measuring stiffness properties of the prosthetic feet to address Aim 1 and prepare the prosthetic foot emulator equipment from human subjects data collection.

During this reporting period, we received approval for the VA Puget Sound R&D human subjects research application for the PISC. The R&D application included information on research data safety, conflict of interest determinations, data management and access, recruitment and study procedures, and study staff. The local VA Puget Sound R&D LSI application in Seattle was also approved.

In addition to the regulatory progress and study preparation progress we made during this reporting period, we also purchased research supplies and equipment. We purchased study prosthetic feet, a study laptop, and a custom Europa+ prosthetic pyramid-embedded load cell sensor (Orthocare Innovations; Mountlake Terrace, WA). The Europa+ device will be used for experimental testing for the design of the multiaxial prosthetic foot emulator and preparing it for use in human subjects testing (**Figure 1**). We facilitated putting the required agreements in place between Humotech and VA Puget Sound and the Minneapolis VA for our research collaboration and purchase agreements with the VA non-profits. SIBCR's (Seattle) is complete and CVRE's (Minneapolis) is being finalized now.

Mechanical testing of the study commercial prosthetic feet in the sagittal and coronal planes is essential to obtain angular stiffness properties to achieve Aim 1 and for input into the multiaxial prosthetic foot emulator prior to initiating human subjects testing. During this reporting period, we experienced COVID-related delays that prolonged the initiation of mechanical testing (*see Actual Problems section below*). However, in the final quarter of this reporting period, we made considerable progress in obtaining the necessary hardware and software to conduct mechanical testing. A Kistler force plate was calibrated and arrived on 02-June-2021 for use in loading the study commercial prosthetic feet during mechanical testing. A mounting bracket for the force plate was designed and fabricated for use with the Robotic Gait Simulator (RGS) used for mechanical testing, and the equipment was mounted (**Figure 2 and Figure 3**). A mechanical hardware shakedown for the RGS R3100 was conducted by the manufacturer (i.e., Mikrolar) on 27-Jul-2021. To attach the prosthetic feet to the testing fixture for mechanical testing using the RGS, a tibial mount was designed, fabricated, and mounted to the RGS on 23-July-2021 (**Figure 4**). Additionally, in order to use the Optitrack motion capture system for collecting kinematics during prosthetic foot mechanical testing, a frame to mount the cameras was designed, fabricated (**Figure 5**) and assembled (**Figure 6**). This frame was designed to house the eight OptiTrack infrared cameras (**Figure 7**) and color video camera to enable stabilized motion capture video during testing. The OptiTrack motion analysis system in-person training was conducted on 25-Aug-2021. The AMTI MC3A 6-axis load cell for use collecting force and moment data in-line with

the prosthetic pylon was calibrated and returned for use in prosthetic foot mechanical testing on 26-July-2021. Furthermore, a 6-channel signal conditioner and external amplifier compatible with the load cell was acquired on 14-Aug-2021. Furthermore, rigid clusters for the reflective marker were designed, fabricated, and attached to prosthetic feet (donned with standard, heel-height appropriate walking shoes), which we mounted to the RGS for mechanical testing (**Figure 8**). An example prosthetic foot being tested as seen through the Optitrack Motive motion capture software is shown in **Figure 9**. Finally, ongoing weekly meetings with BioRobotics simVITRO software engineers were conducted to continue remote installation to use simVITRO software architecture to control the RGS and collect prosthetic foot mechanical testing data. A five-session virtual training with simVITRO has been scheduled with dates ranging from August 31-September 16, 2021.

In advance of the simVITRO trainings and installations, we have begun quasi-static testing of commercial prosthetic feet using the RGS, the in-line load cell, and the OptiTrack camera system at three fixed sagittal and coronal plane angles (**Figure 10**). Testing was performed by applying quasi-static loads to the prosthetic feet at three discrete coronal positions (i.e., neutral, -10° to simulate loading the medial foot and $+10^\circ$ to simulate loading the lateral foot) at a sagittal pylon progression angle (e.g., -10° to simulate heel loading during walking). The loading platform was moved towards the prosthetic foot at a fixed rate of 20 mm/s. The heels and forefeet were loaded to the maximum of the user body weight as determined by the manufacturers' guidelines. Six consecutive cycles of loading and unloading were completed during each test. Force data were collected using a 6-axis load cell that was attached proximal to and in-line with the prosthetic foot. The 8-camera OptiTrack motion capture system was used to collect displacement data from the reflective marker cluster which were adhered to the loading platform, the prosthetic foot within the foot shell and shoe, and the load cell, which defined the coordinate system (**Figure 11**). Example force data (from the in-line load cell) and displacement data (from the Optitrack motion analysis system) collected during quasi-static testing is shown in **Figure 12**. Next, we will mechanically test prosthetic feet to determine their stiffness properties, which will take place after the simVITRO installation and training. This mechanical testing informs the design of the multiaxial prosthetic foot emulator.

We have also been working with Humotech on the multiaxial prosthetic foot emulator that will be used during human subjects testing. Hardware and software development is underway for the multiaxial prosthetic foot emulator design including controller design and testing. Bimonthly meetings and weekly email communications with the Humotech team are ongoing. Specifically, the Humotech team is performing experiments with a prototype controller (**Figure 13**) that adds a measurement of heel deflection necessary for the multiaxial prosthetic foot emulator. The prototype controller has three reference curves by which to define its behavior, each corresponding to different stance phases (**Figure 14**). The hardware design of the multiaxial prosthetic foot emulator is also ongoing. The Humotech team developed a Computer Aided Design (CAD) of the multiaxial prosthetic foot emulator (**Figure 15**). The CAD shows some of the features to be integrated, including modular forefoot lengths, modular weights, and a heel that can sustain loads representative of the target study population of individuals with transtibial amputation (designed based on results from the quasi-static mechanical testing conducted on commercial prosthetic feet).

Study staff Elizabeth Halsne and Talia Ruxin have continued ongoing training in biomechanical data collection, mechanical testing hardware and software, and human subjects research. We have continued to communicate with collaborating sites to develop and refine study methods and coordinate consistent equipment.



Figure 1: The Europa+ sensor as viewed from top (left) showing prosthetic pyramid adapter, and from the bottom (right) with custom wiring to interface with multi-axial prosthetic foot emulator equipment for testing to achieve equipment readiness for human subjects data collection.

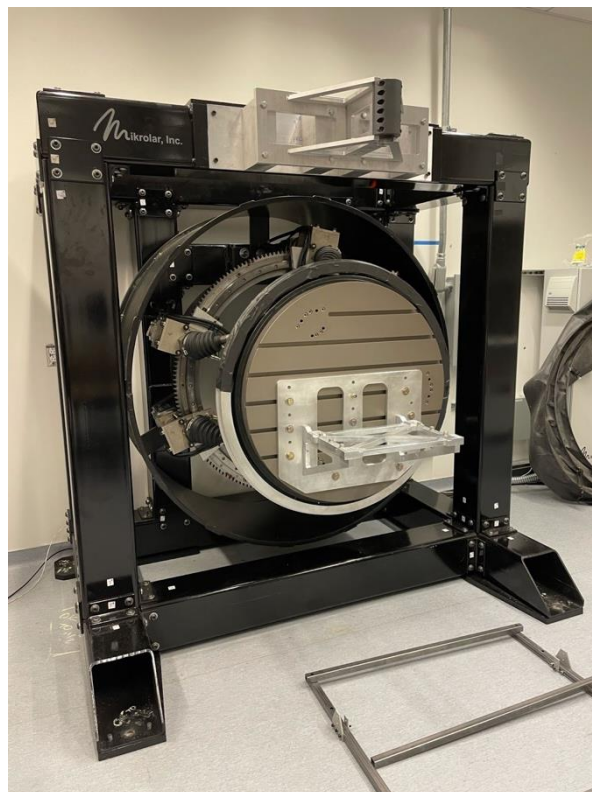

Figure 2: The Robotic Gait Simulator (RGS) used for mechanical testing of study prosthetic feet is shown above with force plate bracket and tibial mount installed. The RGS will be used to collect sagittal and coronal plane angular stiffness properties of commercial prosthetic feet for input to the multi-axial emulator.

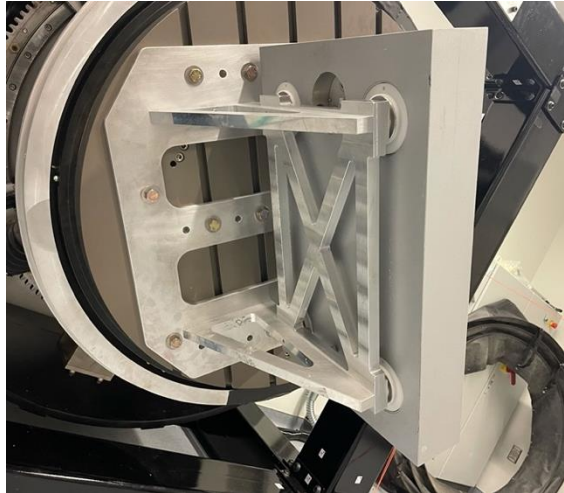

Figure 3: The Kistler force plate is shown mounted on the bracket of the RGS to serve as the loading platform and collect center of pressure data for prosthetic foot mechanical testing.



Figure 4: The prosthetic foot tibial mount shown above attached to the RGS which will be used to attach commercial prosthetic feet during mechanical testing.



Figure 5: The motion capture camera mounting frame design was fabricated in-house to mount cameras for prosthetic foot mechanical testing data collection (frame members shown above in yellow).

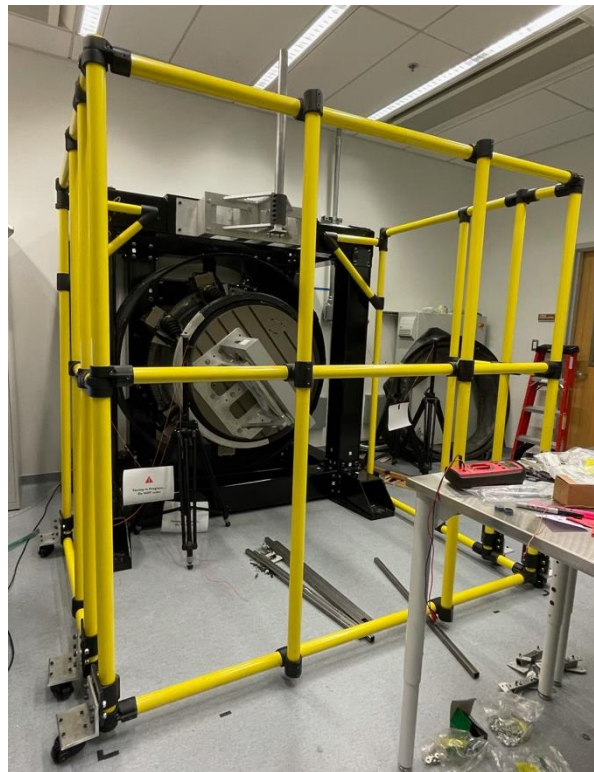

Figure 6: The camera mounting frame was designed, built, assembled, and installed around the RGS in preparation for prosthetic foot mechanical testing.



Figure 7: The OptiTrack cameras were installed and configured around the RGS to capture kinematic data as part of prosthetic foot mechanical testing.

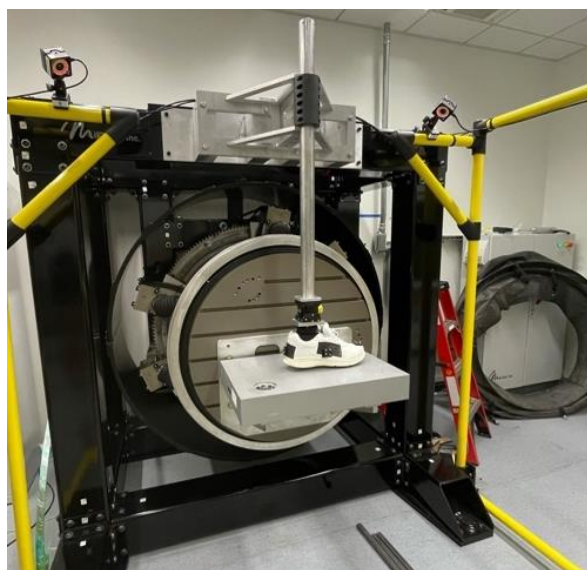

Figure 8: An example study commercial prosthetic foot within a shoe, shown mounted to the RGS for quasi-static mechanical testing.

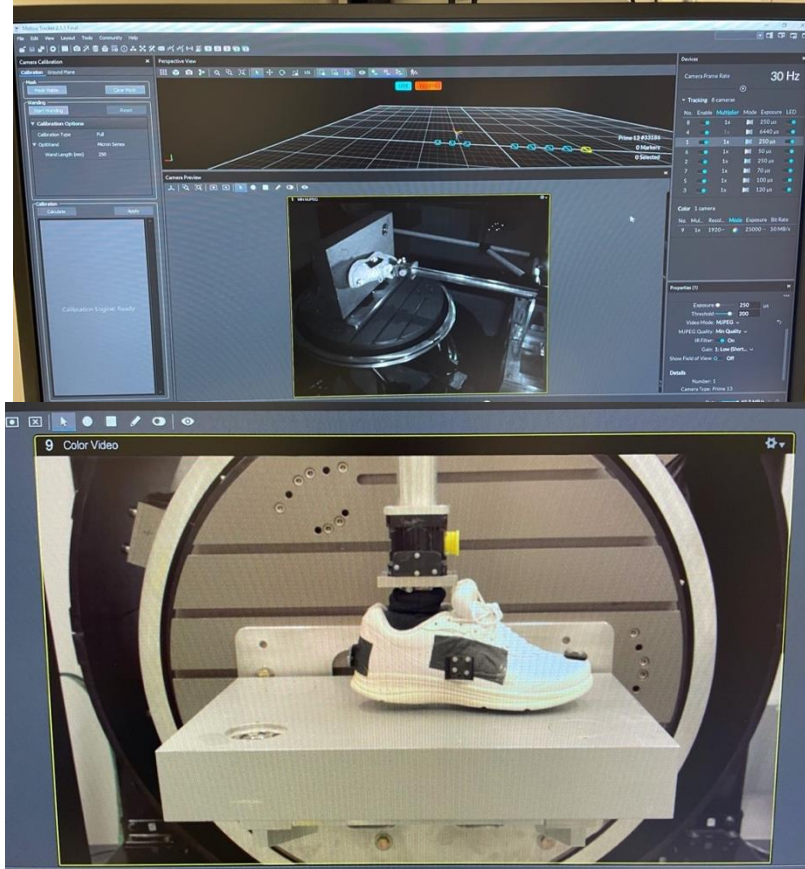

Figure 9: Rigid marker clusters attached to a prosthetic foot within a shoe mounted to the RGS for testing (top) and a close-up of a prosthetic foot being tested (bottom) as seen through the Optitrack Motive software.



Figure 10: Initial quasi-static testing of prosthetic feet using the RGS, the motion capture system, and in-line load cell has begun. Example study commercial prosthetic foot shown undergoing quasi-static testing depicted with sagittal plane view (left), +10 deg coronal plane view to collect lateral foot stiffness properties (center), and -10 deg coronal plane view to test medial foot stiffness properties (right).



Figure 11: Rigid clusters of reflective markers on the heel (left) and forefoot (right) of a prosthetic foot and shoe are shown. These markers are detected by the 8-camera Optitrack motion capture system to track kinematics during mechanical testing.

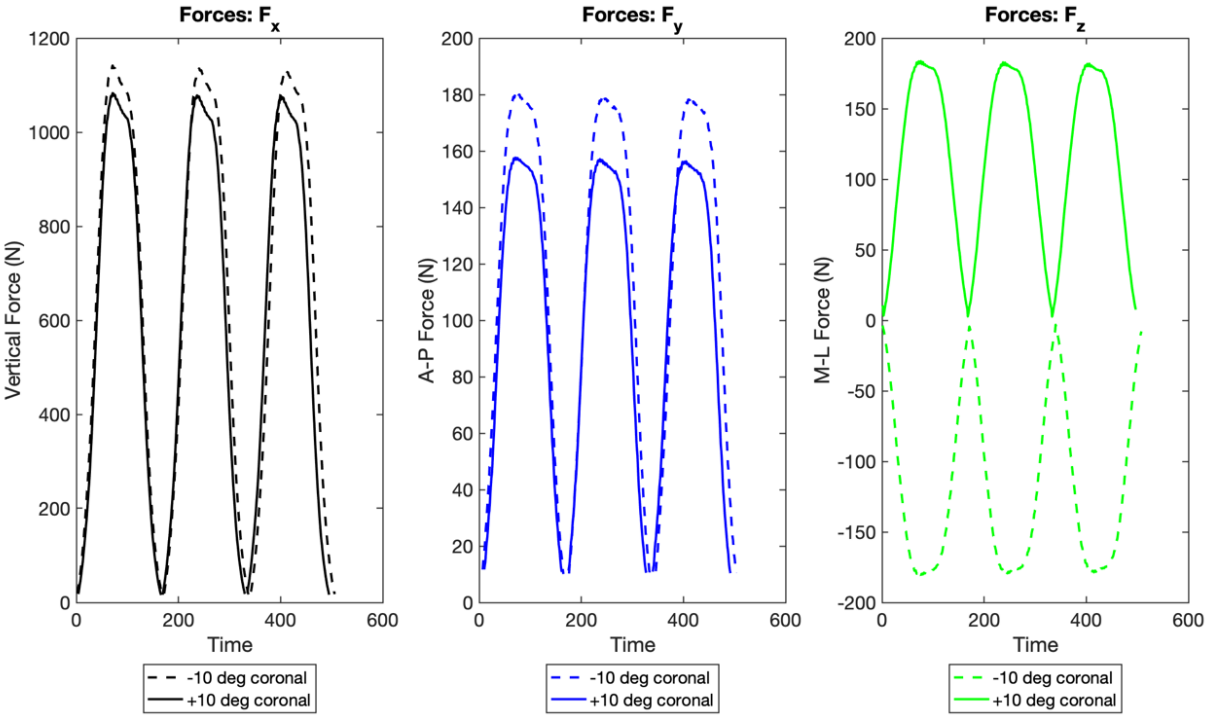

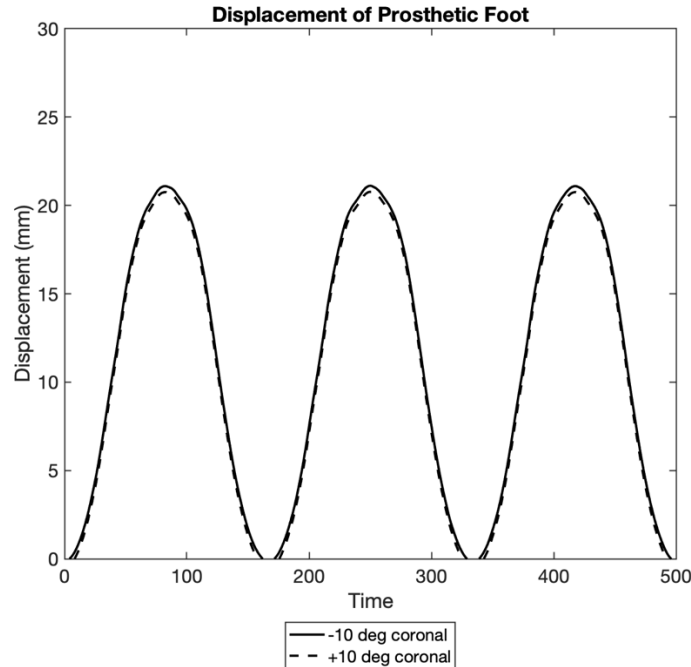

Figure 12: Force data from in-line load cell (top) and displacement data from Optitrack motion capture system (bottom) from an example study commercial prosthetic foot collected during quasi-static mechanical testing to inform the design of the prosthetic foot emulator heel component as an important step towards future human subjects data collection.

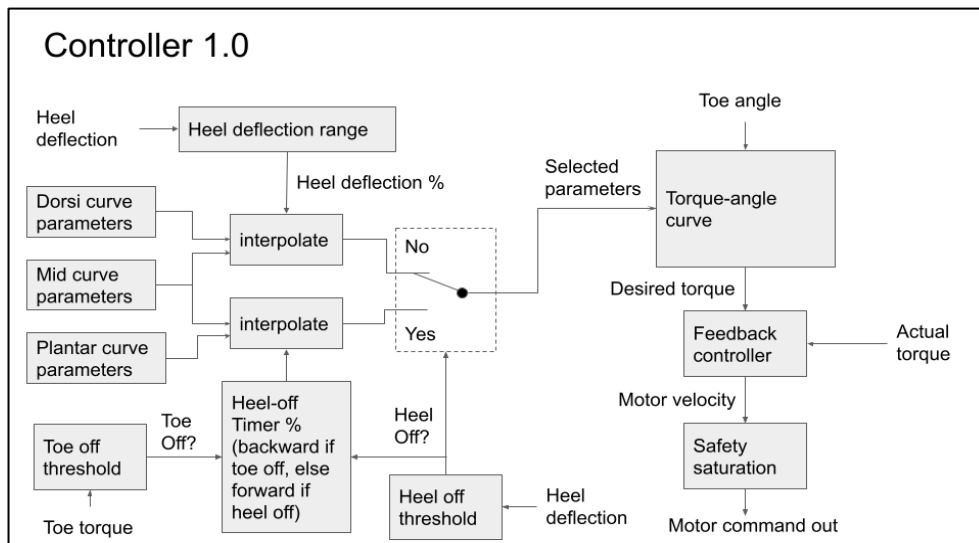

Figure 13: Controller 1.0 describes the prototype controller logic for the prosthetic foot emulator (PFE). During PFE operation, the controller interpolates between two of the three reference curves (specifically the solid curves in **Figure 14**, below) based on the current measurement of heel deflection to create a new torque curve. If the heel is not in contact with the ground, however, the controller instead transitions from the second to the third

curve over a set time period. The resulting torque-angle curve, a hybrid of two reference curves, is then sampled at the PFE's current angle to determine the desired torque.

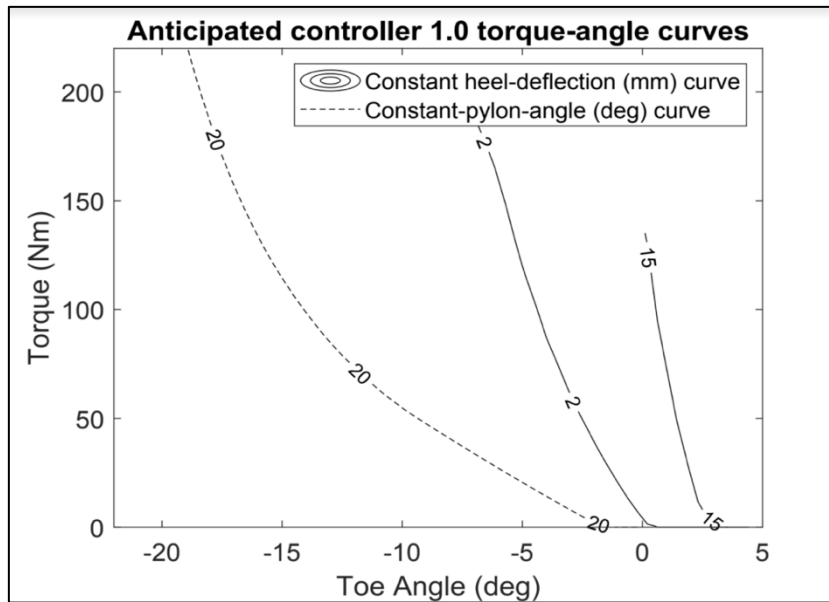

Figure 14: Anticipated prosthetic foot emulator controller 1.0 torque-angle curves describes three example torque-angle curves which the prototype controller could target. These are derived from a simulation of a commercial prosthetic foot. This simulation output is equivalent to the data to be produced by the RGS describing the real commercial feet to be tested. Figure 13 shows how the information captured from the RGS is transformed into the inputs for the prototype controller, by which it can emulate the foot that was tested.

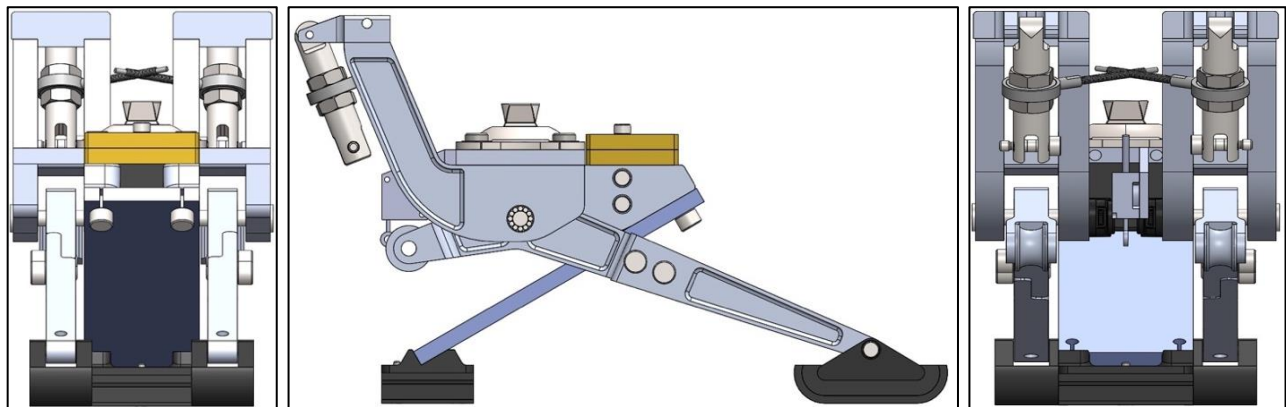

Figure 15: Front, side, and rear views of the multi-axial foot emulator CAD containing improvements and additional features designed to improve reliability and function.

What opportunities for training and professional development has the project provided?

Nothing to Report.

How were the results disseminated to communities of interest?

Nothing to report.

What do you plan to do during the next reporting period to accomplish the goals?

1. Continued bimonthly virtual meetings with Humotech working toward design updates and fabrication of the multiaxial prosthetic foot emulator
2. Complete mechanical testing of study prosthetic feet to characterize the torque vs. angle profiles in the coronal and sagittal plane for input to the multiaxial prosthetic foot emulator
3. Continued purchase of necessary research equipment and supplies including study prosthetic feet
4. Once we have received remaining regulatory approvals (e.g., HRPO) and have completed mechanical testing of all study prosthetic feet (to provide input data for the prosthetic foot emulator), and once design, fabrication and installation of the prosthetic foot emulator is completed, we will begin recruitment for human subjects data collection.

4. IMPACT:

What was the impact on the development of the principal discipline(s) of the project?

Nothing to Report.

What was the impact on other disciplines?

Nothing to Report.

What was the impact on technology transfer?

Nothing to Report.

What was the impact on society beyond science and technology?

Nothing to Report.

5. CHANGES/PROBLEMS:

Changes in approach and reasons for change

Nothing to report.

Actual or anticipated problems or delays and actions or plans to resolve them

During this reporting period, the COVID-19 pandemic caused unavoidable delays in the delivery of hardware and software infrastructure (VA resources) that are necessary for mechanical testing of prosthetic feet. Additionally, there were VA facilities-related delays in installation of mechanical testing hardware. We have recently been able to resolve several delays related to installation of mechanical testing hardware within the reporting period (i.e., acquiring, calibrating, and installing components of the RGS). Additionally, we have scheduled virtual trainings with simVITRO for the month of September, 2021 to enable full use of the RGS for necessary mechanical testing of prosthetic feet. There remains an anticipated delay related to necessary electrical modifications for equipment power requirements. Specifically, in order to use the prosthetic foot emulator within the RGS to perform validation mechanical testing of the emulated foot conditions prior to human subjects data collection, there needs to be additional 3-phase power receptacles installed in the biomechanical testing laboratory. We continue to work with VA facilities by maintaining biweekly communication between their representatives and members from the Center for Limb Loss and Mobility at the VAPSHCS to acquire necessary electrical work quotes, contracts, and permits and expect resolution of this issue. In the meantime, we have been able to proceed with quasi-static mechanical testing in advance of the simVITRO installation and training and will begin mechanical testing of the prosthetic feet to determine their stiffness properties to achieve Aim 1 and progress towards human subjects data collection once the simVITRO control software has been installed.

In order to minimize project delays once the hardware and software are acquired, we are continuing to meet with Humotech to discuss how to optimize mechanical testing methods and multi-axial prosthetic foot emulator design considerations and have ongoing weekly meetings with simVITRO software representatives. We have also focused on obtaining components such as the calibrated force plate and load cell, external amplifier, and OptiTrack frame which has allowed us work-arounds to initiate some basic mechanical testing of prosthetic feet to aid in prosthetic foot emulator design (see *Accomplishments section*).

Changes that had a significant impact on expenditures

A significant portion of the planned Year 1 expenditures to have not yet occurred because of the delays described above. We anticipate spending for the period from 1-Aug-2020 to 31-Jul-2021 of originally budgeted. Spending reductions have been across the board this year, reflective of overall progress, but most notable in the local personnel, equipment and subaward categories. These are delays rather than cost reductions. Now that some mechanical testing has begun, larger amounts of personnel effort will be needed for this project. We anticipate both sites (Seattle and Minneapolis) paying Humotech for their PFEs in the coming year: Seattle has already made its first payment. When Minneapolis/CVRE's complete their human subjects regulatory approvals, their subaward will be signed and begin to support costs (such as their PFE purchase) shortly thereafter. We anticipate using these funds over the coming years for their original purpose.

In addition, the uneven ground treadmill that we budgeted for in Year 1 was unexpectedly purchased by the VA last year. We will use the funds originally planned to support this purchase in other ways over the coming year that will be important to support the work of the project. Specifically, we have revised our staffing plan from including a graduate student/post-doc to supporting a PhD-level Research Prosthetist, which will be more expensive.

Significant changes in use or care of human subjects, vertebrate animals, biohazards, and/or select agents

Significant changes in use or care of human subjects

Nothing to report.

Significant changes in use or care of vertebrate animals

Nothing to report.

Significant changes in use of biohazards and/or select agents

Nothing to report.

6. PRODUCTS:

- **Publications, conference papers, and presentations**

- Journal publications.**

- Nothing to report.

- Books or other non-periodical, one-time publications.**

- Nothing to report.

- Other publications, conference papers and presentations.**

- Nothing to report.

- **Website(s) or other Internet site(s)**

Nothing to report.

- **Technologies or techniques**

Nothing to report.

- **Inventions, patent applications, and/or licenses**

Nothing to report.

- **Other Products**

None to report.

7. PARTICIPANTS & OTHER COLLABORATING ORGANIZATIONS

What individuals have worked on the project?

Name: David Morgenroth, MD

Project Role: PI

Researcher Identifier (e.g. ORCID ID):

Nearest person month worked: 5 calendar months

Contribution to Project: As PI, Dr. Morgenroth has led study team meetings, coordinated with Humotech on initial purchase contracting discussions, worked with study staff to put local mechanical testing approvals in place, had primary responsibility for all DoD reporting, and documentation, and overseen work on protocol finalization and modification of the initial application to the VA Central IRB.

Funding Support: VA contributed effort

Name: Talia Ruxin

Project Role: Study Coordinator

Researcher Identifier (e.g. ORCID ID):

Nearest person month worked: 2 calendar months

Contribution to Project: Drafted and revised all documents relevant to the submission of the initial application to the VA Central IRB, to the VA R&D Committees, and to HRPO, coordinated submission of the initial application, scheduled multisite team meetings and ongoing meetings with Humotech. Assisted in equipment preparation and quasi-static mechanical testing of commercial prosthetic feet.

Name: Elizabeth Halsne

Project Role: Graduate Research Assistant

Researcher Identifier (e.g. ORCID ID):

Nearest person month worked: 1 calendar month

Contribution to Project: Assisted with drafting all documents relevant to the submission of the initial human subjects application to the VA Central IRB, modified the initial human subjects application in response to the VA Central IRB, participated in meetings with investigators regarding human subject testing protocol, participated in ongoing meetings with Humotech to inform procedures for mechanical testing of prosthetic feet, and participated in ongoing meetings to resolve remaining anticipated issues with obtaining necessary VA electrical work prior to mechanical testing of the prosthetic foot emulator. Led equipment preparation and initial quasi-static mechanical testing of commercial prosthetic feet to inform design of prosthetic foot emulator heels for future use in human subjects data collection.

Name: Andrew Sawers

Project Role: co-I

Researcher Identifier (e.g. ORCID ID):

Nearest person month worked: 1

Contribution to Project: Dr. Sawers participated in team meetings. In addition, based on his expertise and previous research in the area, he has contributed to the project by providing

recommendations for the assessment and measurement of balance and falls in lower limb amputees (e.g., providing data that examines the influence of foot type on balance ability and leading a discussion based on this data, identifying, reviewing and presenting a single item fear of falling questions, accompanied by appropriate citations to facilitate data collection, creating a custom version of his LLP User Fall Circumstance and Consequence Survey for baseline testing, presenting a conceptual model characterizing the continuum of balance and falls in LLP users to guide and inform plans for data collection, analysis and interpretation).

Has there been a change in the active other support of the PD/PI(s) or senior/key personnel since the last reporting period?

Dr. Morgenroth's other active DoD grant (specified below) is ending this month after a no-cost extension from August 2020 to August 2021 end date:

Title: A Prosthetic Foot Emulator to Optimize Prescription of Prosthetic Feet in Veterans and Service Members with Leg Amputations
W81XWH-16-1-0569 / OP150005
9/1/2016-8/31/2021

Additionally, the following projects received no-cost extensions moving their end dates:

Title: The Evaluation and Redesign of Transmetatarsal Prosthetics to Reduce Peak Plantar Pressures
Funder: National Institutes of Health, R21HD095516
Performance Period: 8/30/2018 – 7/31/2022
Role in Project: Investigator
Time Commitment: 5%

Title: Improving Footwear Options for Women and Men Veterans with Amputations
Funder: VA
Performance Period: 07/01/2018 – 06/30/2022
Role in Project: Investigator
Time Commitment: 5%

What other organizations were involved as partners?

Minneapolis VA Health Care System (MVAHCS)

Center for Veterans Research and Education

One Veterans Drive

Minneapolis, MN 55417-2309

Site PI: Sara Koehler-McNicholas (SKM)

Investigator: Andrew Hansen (AH)

Staff: MVAHCS Study Staff (SS) will include Research Coordinator and Research Prosthetist

Contribution: Supported local effort to start-up study in advance of the project subaward between SIBCR and CVRE being fully signed.

University of Illinois at Chicago (UIC)

Department of Kinesiology 502A

1919 W. Taylor Street (AHSB)

Chicago, IL 60612

Investigator: Andrew Sawers (AS)

*Note that UIC is not a human subjects data collection site.

Contribution: Collaboration. Aids in study methodology and survey development.

Role: Subawardee as per proposal

Human Motion Technologies LLC

U-PARC Building A2

630 William Pitt Way

Pittsburgh, PA 15238

Consultants: Joshua Caputo and Tianyao Chen

Role: Vendor as per proposal, designing and manufacturing the multi-axial prosthetic foot emulator.

8. SPECIAL REPORTING REQUIREMENTS

COLLABORATIVE AWARDS:

There are no Partnering PIs involved in this project.

QUAD CHARTS:

Quad Chart is attached

9. APPENDICES:

Appendix 1: VA REDCap Project Setup and Online Designer were used to enter the VA Central IRB approved self-report questionnaire questions for later data entry purposes after we have all regulatory approvals and begin human subjects testing.

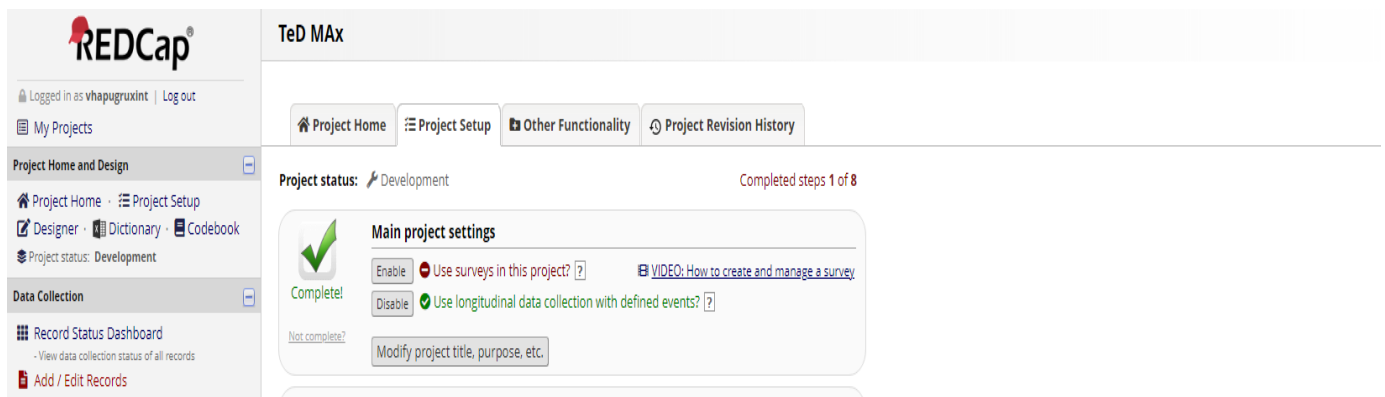

The screenshot displays the REDCap interface for a project named 'TeD MAX'. The user is logged in as 'vhapugruxint'. The interface includes a navigation menu on the left with options like 'Project Home and Design', 'Data Collection', and 'Record Status Dashboard'. The main content area shows the 'Project status' as 'Development' and 'Completed steps 1 of 8'. Under 'Main project settings', there are two settings: 'Use surveys in this project?' (checked) and 'Use longitudinal data collection with defined events?' (checked). A 'Modify project title, purpose, etc.' button is also visible.

REDCap
 Logged in as vhapugruxint | Log out
 My Projects

Project Home and Design

- Project Home
- Project Setup
- Designer
- Dictionary
- Codebook
- Project status: Development

Data Collection

- Record Status Dashboard
- Add / Edit Records

Applications

- Alerts & Notifications
- Calendar
- Data Exports, Reports, and Stats
- Data Import Tool
- Data Comparison Tool
- Logging
- Field Comment Log
- File Repository
- User Rights and DAGs
- Customize & Manage Locking/E-signatures
- Data Quality
- API and API Playground

Help & Information

- Help & FAQ
- Video Tutorials
- Suggest a New Feature
- Contact REDCap administrator

TeD MAX

- Project Home
- Project Setup
- Online Designer
- Data Dictionary
- Codebook

Create snapshot of instruments
 VIDEO: How to use this page
 Last snapshot: never

This page allows you to build and customize your data collection instruments one field at a time. You may add new fields or edit existing ones. New fields may be added by clicking the Add Field buttons. You can begin editing an existing field by clicking on the Edit icon. If you decide that you do not want to keep a field, you can simply delete it by clicking on the Delete icon. To reorder the fields, simply drag and drop a field to a different position within the form below. NOTE: While in development status, all field changes will take effect immediately in real time. Are you using Action Tags yet? If not, learn about Action Tags here.

Return to list of instruments

Current instrument: Falls (Fear of Falling)

Preview instrument

Matrix group: fall_fear

Variable: fear_fall

	Very afraid	Afraid	Somewhat afraid	Not at all afraid
How afraid are you that you will fall...? <small>* must provide value</small>	<input type="radio"/>	<input type="radio"/>	<input type="radio"/>	<input type="radio"/>

Variable: fear_fall_hurt

	Very afraid	Afraid	Somewhat afraid	Not at all afraid
How afraid are you that you will fall and hurt yourself ...? <small>* must provide value</small>	<input type="radio"/>	<input type="radio"/>	<input type="radio"/>	<input type="radio"/>

Matrix group: fear_falling_avoidance

Variable: dont_try

	Many Things	Some Things	A few things	Nothing
Are there things you don't try to do because you might fall? <small>* must provide value</small>	<input type="radio"/>	<input type="radio"/>	<input type="radio"/>	<input type="radio"/>

Variable: stopped_try

TeD MAX

- Project Home
- Project Setup
- Online Designer
- Data Dictionary
- Codebook

Create snapshot of instruments
 VIDEO: How to use this page
 Last snapshot: never

This page allows you to build and customize your data collection instruments one field at a time. You may add new fields or edit existing ones. New fields may be added by clicking the Add Field buttons. You can begin editing an existing field by clicking on the Edit icon. If you decide that you do not want to keep a field, you can simply delete it by clicking on the Delete icon. To reorder the fields, simply drag and drop a field to a different position within the form below. NOTE: While in development status, all field changes will take effect immediately in real time. Are you using Action Tags yet? If not, learn about Action Tags here.

Return to list of instruments

Current instrument: Demographics

Preview instrument

Variable: study_id

Study ID
Ex: S12 or M03

NOTE: The field above is the record ID field and thus cannot be deleted or moved. It can only be edited.

Variable: site

Study Site

- Seattle VA
- Minneapolis VA

Consent Information

Variable: date_consent

Date participant signed consent form Today MM-DD-YYYY

REDCap
 Logged in as vhapugruxint | Log out
 My Projects

Project Home and Design

- Project Home
- Project Setup
- Designer
- Dictionary
- Codebook
- Project status: Development

Data Collection

- Record Status Dashboard
- Add / Edit Records

Applications

- Alerts & Notifications
- Calendar
- Data Exports, Reports, and Stats
- Data Import Tool
- Data Comparison Tool
- Logging
- Field Comment Log
- File Repository
- User Rights and DAGs
- Customize & Manage Locking/E-signatures
- Data Quality
- API and API Playground

Help & Information

- Help & FAQ
- Video Tutorials
- Suggest a New Feature
- Contact REDCap administrator

A Prosthetic Foot Test-Drive Strategy for Improving Stability and Falls-Related Outcomes in Veterans with Leg Amputations

OP190048 / W81XWH-20-1-0291



PI: David Morgenroth MD

Org: Seattle Institute for Biomedical and Clinical Research Award Amount: \$2,000,000

Study/Product Aim(s)

- Determine the effects of commercial prosthetic feet of varying stiffness on stability and falls-related outcomes in Service members and Veterans with transtibial amputation (TTA)
- Determine whether a multiaxial prosthetic foot emulator can be used to predict stability and balance-confidence outcomes with corresponding commercial prosthetic feet in Veterans with TTA
- Determine whether a brief trial of commercial prosthetic feet can predict longer-term stability and balance-confidence outcomes in Veterans with TTA

Approach

We will conduct a repeated measures study with cross sectional and longitudinal components to study foot preference, falls-related, and mobility outcomes for a variety of commercially available prosthetic feet compared with emulated versions of those feet in Veterans and Service members with lower limb amputation.

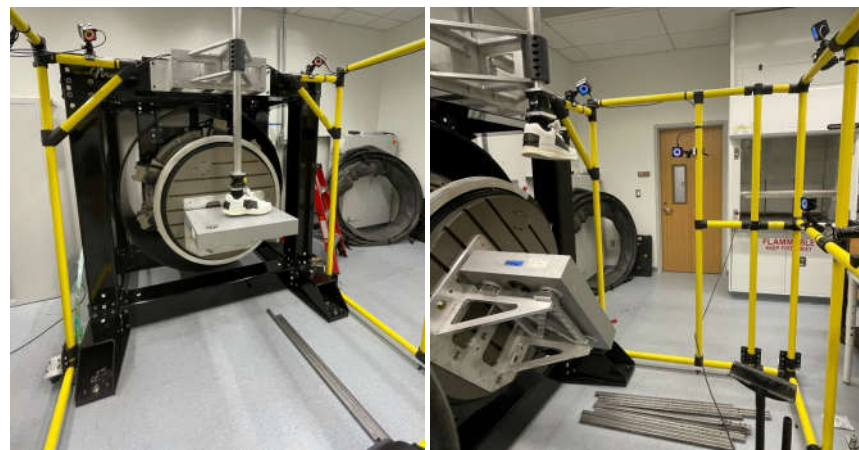

Accomplishment: We are working on the mechanical testing of commercial prosthetic feet for input into the prosthetic foot emulator. Shown above are the Robotic Gait Simulator with a prosthetic foot within a shoe attached (left) and the OptiTrack camera frame in front of the RGS with the 8 motion capture cameras (right, yellow).

Timeline and Cost

Activities	Budget Year	20-21	21-22	22-23	23-24
Obtain Human Subjects approvals					
Mechanical testing of prosthetic feet					
Human subjects data collection					
Data analysis and results dissemination					
Estimated Budget (\$2M)		\$859K	\$397K	\$367K	\$377K

Updated: 08/31/2021

Goals/Milestones (Example)

CY20-21 Goal – Study preparation and Institutional approvals

- Obtain R&D Committee approval for non-human subjects work
- Develop and finalize self-report questionnaire packets and data spreadsheet
- Obtain human subjects approval (almost complete, *pending HRPO approval*)
- Initiate mechanical testing of prosthetic feet and emulator fabrication

CY21-22 Goals – Completion of mechanical testing, emulator delivery, and initiation of human subjects testing

- Complete mechanical testing of prosthetic feet and emulator fabrication
- Recruit participants and conduct human subjects data collection

CY22-23 Goal – continued human subjects testing and preliminary analyses

- Continue human subjects data collection
- Analyze preliminary data set for dissemination at scientific meetings

CY23-24 Goal – Completion of testing, analysis and dissemination

- Finalize human subjects data collection
- Analyze final data set and disseminate findings

Comments/Challenges/Issues/Concerns

Budget Expenditure to Date

Projected Expenditure: \$2,000,000. Actual Expenditure: \$155,842