

# Kalki: High Assurance Software-Defined IoT Security

## Problem

Despite the DoD's current use of Internet of Things (IoT) devices in supervisory control and data acquisition (SCADA) systems, and its interest in using such devices in tactical systems, adoption of IoT has been slow, mainly due to security concerns (e.g., reported vulnerabilities, untrusted supply chains). At the same time, the DoD recognizes the rapid pace at which the IoT commercial marketplace is evolving, and its urgency to embrace commodity technologies to match its adversaries.

## Solution

Move part of security enforcement to the network to enable the integration of IoT devices into DoD systems, even if the IoT devices are not fully trusted or configurable, by creating an IoT security platform that is provably resilient to a collection of prescribed threats.

## The "Software-Defined" Aspect

Use software-defined networking (SDN) and network function virtualization (NFV) to create a highly dynamic IoT security platform.

## The "High Assurance" Aspect

Use the open-source uber extensible Micro-Hypervisor Framework (uberXMHF) to develop secure extensions that enforce security properties of critical elements of the software-defined IoT security platform at runtime, on commodity platforms.

## Kalki IoT Security Platform Features

- Has flexible policies to define states, transitions and actions.
- Can protect from both cyber and kinetic attacks.
- Uses different network defenses for each device and state.
- Adapts to device-specific vulnerabilities or limitations.

The Kalki IoT Security Platform enables the integration of IoT devices into DoD systems, even if the IoT devices are **not fully trusted** or configurable.

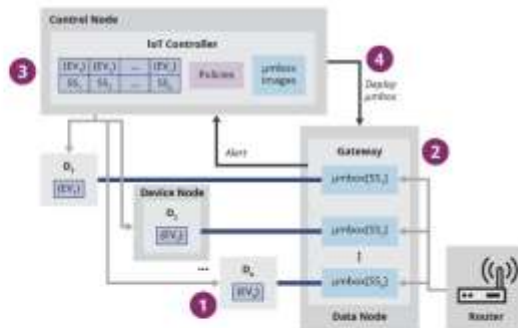

- 1 Each IoT Device  $D_i$  senses/control a set of environment variables (EV)
- 2 Network traffic to/from each device is tunneled through jumbos that implement the desired network defense for the current system state  $D_i$ ,  $jumboSS_1 = Firewall$ ,  $D_i$ ,  $jumboSS_2 = IPS, \dots$
- 3 IoT Controller maintains a shared namespace (comprised of EV) and security state (SS) for each device  $SS = \{Alerts, Suspicious, Alerts\}$
- 4 Changes in the shared namespace are evaluated by policies and may result in the deployment of new jumbos

Security sensitive areas of the system are protected by the uberXMHF extensible and performant micro-hypervisor framework that provides three key runtime capabilities:

- a. isolation,
- b. mediation,
- c. attestation.

- The micro-hypervisor verifies the integrity of the jumbo images when they are loaded, to ensure that each device has the correct network defenses.
- Signing network packets ensures that they are routed through the proper jumbos for each specific device in the Data Node.

## Year 3 Highlights

1. The new version of the platform prototype using docker containers showed significant performance and scalability improvements—threat reaction time is 3 seconds (90% improvement) with support for up to 125 connected devices (80% improvement).
2. User interface improvements to the Dashboard UI significantly reduce the time and complexity of adding new IoT devices, especially with respect to policy definition.



3. Architecture changes enable the system to adapt to different network layouts and to be deployed on low-cost hardware such as a Raspberry Pi.
4. We created a formal model of our security architecture using the Alloy modeling language and successfully validated its designed-in resilience properties.
5. We demonstrated that the architecture provides intrinsic security against a broad spectrum of attacks, including nine published attacks against such software-defined architectures.
6. Kalki code is available as open-source on Github to invite the community to test or adapt the platform. Kalki platform: <https://github.com/SEI-TAS/kalki-node-setup/wiki>; uberXMHF microhypervisor: <https://uberxmhf.org/>

Copyright 2020 Carnegie Mellon University.

This material is based upon work funded and supported by the Department of Defense under Contract No. FA8702-15-D-0002 with Carnegie Mellon University for the operation of the Software Engineering Institute, a federally funded research and development center.

The view, opinions, and/or findings contained in this material are those of the author(s) and should not be construed as an official Government position, policy, or decision, unless designated by other documentation.

NO WARRANTY. THIS CARNEGIE MELLON UNIVERSITY AND SOFTWARE ENGINEERING INSTITUTE MATERIAL IS FURNISHED ON AN "AS-IS" BASIS. CARNEGIE MELLON UNIVERSITY MAKES NO WARRANTIES OF ANY KIND, EITHER EXPRESSED OR IMPLIED, AS TO ANY MATTER INCLUDING, BUT NOT LIMITED TO, WARRANTY OF FITNESS FOR PURPOSE OR MERCHANTABILITY, EXCLUSIVITY, OR RESULTS OBTAINED FROM USE OF THE MATERIAL. CARNEGIE MELLON UNIVERSITY DOES NOT MAKE ANY WARRANTY OF ANY KIND WITH RESPECT TO FREEDOM FROM PATENT, TRADEMARK, OR COPYRIGHT INFRINGEMENT.

[DISTRIBUTION STATEMENT A] This material has been approved for public release and unlimited distribution. Please see Copyright notice for non-US Government use and distribution.

This material may be reproduced in its entirety, without modification, and freely distributed in written or electronic form without requesting formal permission. Permission is required for any other use. Requests for permission should be directed to the Software Engineering Institute at [permission@sei.cmu.edu](mailto:permission@sei.cmu.edu).

Carnegie Mellon® is registered in the U.S. Patent and Trademark Office by Carnegie Mellon University.

DM20-0816

# Kalki IoT Security Platform

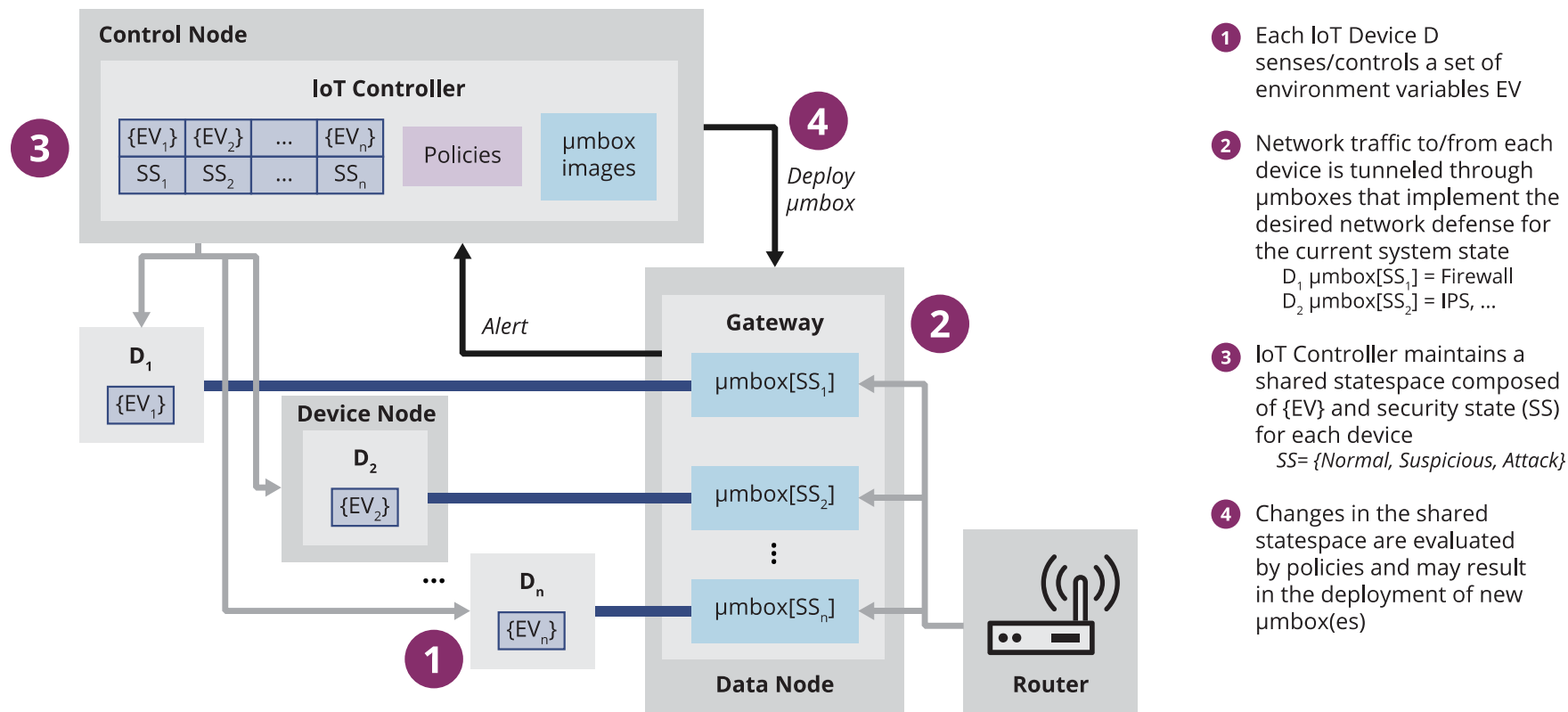

# Kalki IoT Security Platform

Carnegie Mellon University
Software Engineering Institute

## KalkiDashboard

Devices
FUNCy View
Configurations ▾

---

### Device Type Configuration

Device Type: DLink Camera ▾

Policy Rules
Policy Rule View
Commands
Alert Types
Umbox Actions

#### Selected Policy Rules

Policy Rule: dic-motion-sense && max-login-attempts

**Sampling Rate Factor:** 1

**Commands:** WeMo Insight - turn-off

Name: Suspicious  
 Umboxes: U2-Auth-Proxy > U3-Brute-Force-Detection > U4-Stat-Monitoring

# The Kalki Team



Sebastian Echeverria  
Grace A. Lewis  
Craig Mazzotta



Amit Vasudevan  
Marc Novakouski  
Keegan Williams



Kyle O'Meara  
Matthew McCormack  
Vyas Sekar