

412TW-PA-22075



DEVELOPMENT OF THE F-104

CLARENCE L JOHNSON

AIR FORCE FLIGHT TEST CENTER
EDWARDS AIR FORCE BASE,
CALIFORNIA

18 JUNE 1957

A
F
F
T
C

APPROVED FOR PUBLIC RELEASE A: DISTRIBUTION IS UNLIMITED.
RELEASED 21 MARCH 2022

AIR FORCE FLIGHT TEST CENTER
EDWARDS AIR FORCE BASE, CALIFORNIA
AIR FORCE MATERIEL COMMAND
UNITED STATES AIR FORCE

REPORT DOCUMENTATION PAGE

Form Approved
OMB No. 0704-0188

Public reporting burden for this collection of information is estimated to average 1 hour per response, including the time for reviewing instructions, searching existing data sources, gathering and maintaining the data needed, and completing and reviewing this collection of information. Send comments regarding this burden estimate or any other aspect of this collection of information, including suggestions for reducing this burden to Department of Defense, Washington Headquarters Services, Directorate for Information Operations and Reports (0704-0188), 1215 Jefferson Davis Highway, Suite 1204, Arlington, VA 22202-4302. Respondents should be aware that notwithstanding any other provision of law, no person shall be subject to any penalty for failing to comply with a collection of information if it does not display a currently valid OMB control number. **PLEASE DO NOT RETURN YOUR FORM TO THE ABOVE ADDRESS.**

1. REPORT DATE (DD-MM-YYYY) 21-03-2022		2. REPORT TYPE Historical Release		3. DATES COVERED (From - To) 18 June 1957	
4. TITLE AND SUBTITLE Development of the F-104				5a. CONTRACT NUMBER	
				5b. GRANT NUMBER	
				5c. PROGRAM ELEMENT NUMBER	
6. AUTHOR(S) Clarence L. Johnson				5d. PROJECT NUMBER	
				5e. TASK NUMBER	
				5f. WORK UNIT NUMBER	
7. PERFORMING ORGANIZATION NAME(S) AND ADDRESS(ES) AND ADDRESS(ES) Air Force Test Center History Office 305 East Popson Ave, Edwards AFB, CA 93524				8. PERFORMING ORGANIZATION REPORT NUMBER 412TW-PA-22075	
9. SPONSORING / MONITORING AGENCY NAME(S) AND ADDRESS(ES) 412th Test Wing 195 E Popson Ave Edwards AFB CA 93524				10. SPONSOR/MONITOR'S ACRONYM(S) N/A	
				11. SPONSOR/MONITOR'S REPORT NUMBER(S)	
12. DISTRIBUTION / AVAILABILITY STATEMENT Approved for public release Distribution Statement A: distribution is unlimited.					
13. SUPPLEMENTARY NOTES Source Code 012100 (This number comes from STINFO via EAFB Technical Library) CA: 412 th Test Wing, Edwards AFB, CA					
14. ABSTRACT This document is a historical document for the F-104.					
15. SUBJECT TERMS Development of the F-104, LR-12236					
16. SECURITY CLASSIFICATION OF: Unclassified			17. LIMITATION OF ABSTRACT None	18. NUMBER OF PAGES 93	19a. NAME OF RESPONSIBLE PERSON 412 TENG/EN (Tech Pubs)
a. REPORT Unclassified	b. ABSTRACT Unclassified	c. THIS PAGE Unclassified			19b. TELEPHONE NUMBER (include area code) 661-277-8615

DEVELOPMENT OF THE F-104

7A-2

Title: F-104 Development Of The F-104

LR 12236
June 18, 1957

Lockheed AIRCRAFT CORPORATION

CALIFORNIA DIVISION

DEVELOPMENT OF THE LOCKHEED F-104
SUPERSONIC FIGHTER

by

Clarence L. Johnson

Vice President - Engineering and Research
Lockheed Aircraft Corporation

To be presented at the National Summer Meeting
of the Institute of the Aeronautical Sciences at
Los Angeles, California, June 18, 1957.



Lockheed AIRCRAFT CORPORATION

CALIFORNIA DIVISION

I. INTRODUCTION

For a considerable period of time after World War II, the developments of fighter aircraft proceeded at a leisurely pace, based on various adaptations of the subsonic pure jet fighter. Between 1945 and 1950, very few new models were prepared and too many of these were based on operational requirements stemming from World War II techniques. Our first real operational experience with jet fighters took place in Korea in 1952. The shortcomings of some of our American design philosophies showed up in spite of the fine record our pilots attained against the MIG-15's in combat. There was universal criticism of our American fighters in regard to their capabilities in ceiling and high altitude maneuverability, as well as their complexity from a maintenance point of view.

At this time, Lockheed was endeavoring to find a successor to the F-80 airplane and many design studies had been undertaken and certain experimental airplanes, such as the XF-90 (Figure 1) constructed and tested. The XF-90 was a heavy penetration fighter for which suitable powerplants were never developed. We became interested in a different fighter approach as a result of discussions with fighter pilots who had flown in Korea and with various Air Force officers. In 1947



XF-90 WITH 3% WING

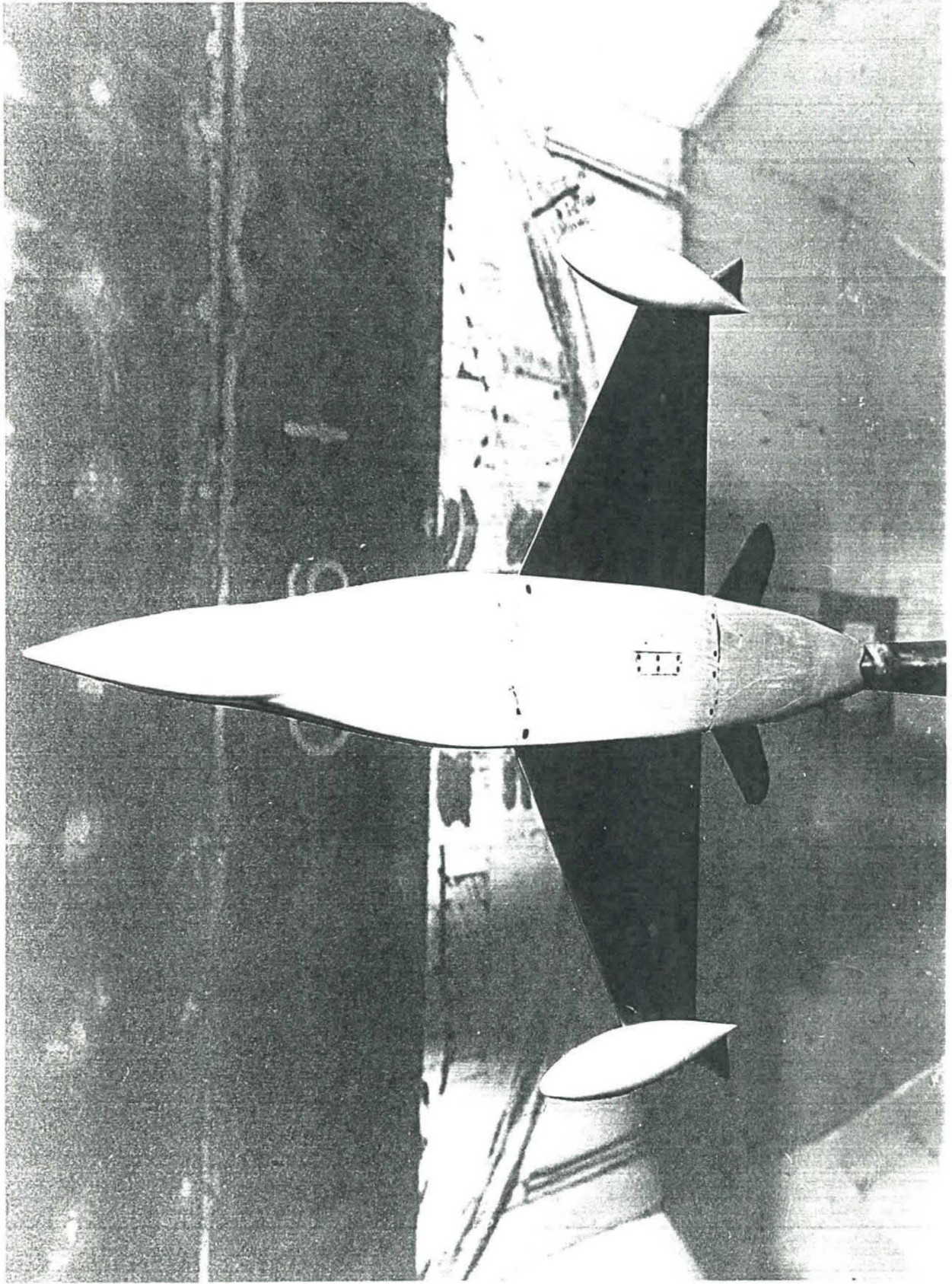

FIG.1

Lockheed AIRCRAFT CORPORATION

CALIFORNIA DIVISION

Lockheed was engaged in the development of a supersonic high altitude ramjet test vehicle, known as the X-7, and a substantial amount of research on configurations, aeroelasticity problems, and aerodynamics pertaining to supersonic flight was being accomplished. It appeared from tests on this vehicle that it was possible to build a low aspect ratio, thin, straight wing aircraft which would have excellent flight characteristics in the Mach number range from 2 to 3. I have covered factors leading to the choice of the straight thin wing in a separate paper. (1)

The actual X-7 flight tests gave us some detailed knowledge on structures which would be difficult to obtain in other than free flight tests. (Figure 2)

An effort was made to convert the XF-90 into a supersonic airplane by installing a 3% thick wing for a series of wind tunnel tests. Other studies led to the design of Lockheed model 205 (Figure 3), utilizing an air duct behind the pilot's canopy, which had several advantages in over-all design layout. To this point, our major efforts were concentrated on airplanes in the 25,000 to 45,000 pound gross weight category. After a visit to the Korean area and discussions with the Air Force, studies were undertaken to see whether or not an airplane of about 15,000 to 18,000 pounds gross weight could be designed which would have high enough performance and satisfactory armament and equipment to stand on

(1) Airplane Configurations for High Speed Flight, by Clarence L. Johnson, presented at the SAE National Aeronautic meeting on October 2, 1953.

X-7 RAMJET TEST VEHICLE

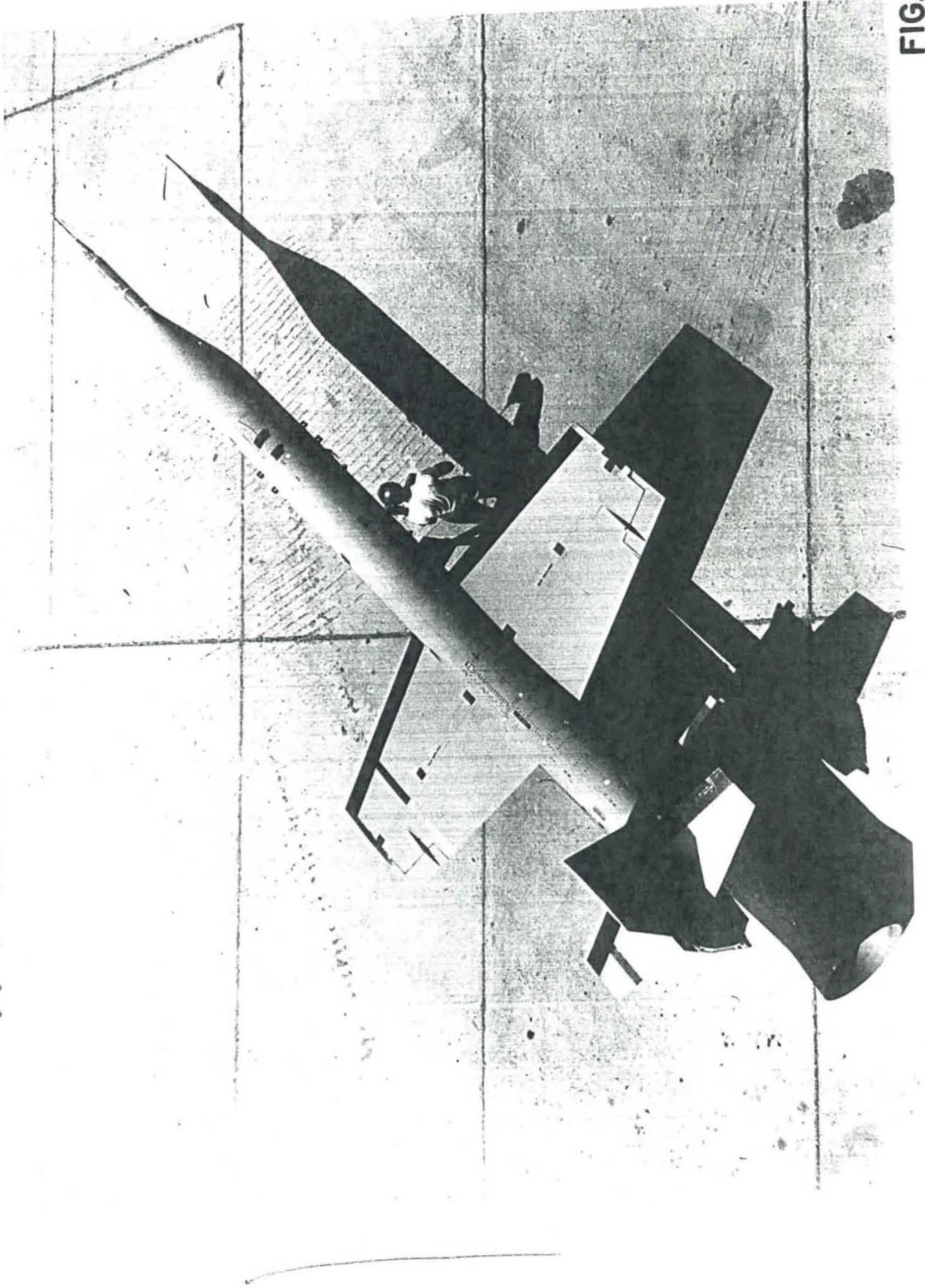

FIG. 2

MODEL
L-205

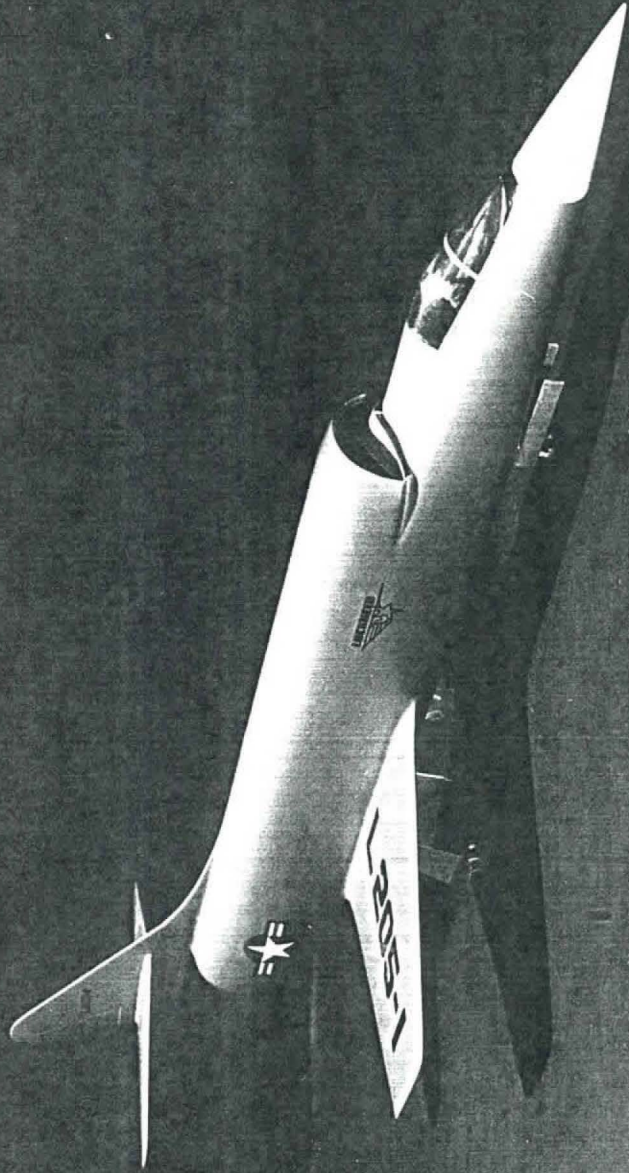

FIG. 3

~~CONFIDENTIAL~~
Lockheed AIRCRAFT CORPORATION

CALIFORNIA DIVISION

its own against fighters of approximately twice that size.

There were two schools of thought on this matter. The large airplane exponents claimed that equal speed, range, and fighting power could not be obtained in a smaller airplane because such fixed items as the pilot size, canopy size, engine thrust per square foot of frontal area, and fixed equipment item weights were a smaller percentage of the large airplane weight than of the smaller one. Likewise, the fuselage cross section and size, in general, would be unfavorable for the smaller airplane, resulting in lower ratios of lift to drag and thrust to drag, even if the same percentage fuel weight could be carried. There was not in existence a small engine which had as good thrust weight ratios or specific fuel consumption as the larger engines then available. These factors were all true at the time; so it was necessary to make some rather major advances on practically all of these fronts before a successful light weight fighter could be developed.

Lockheed AIRCRAFT CORPORATION

CALIFORNIA DIVISION

II. THE "STRIPPED" PHILOSOPHY

There was a considerable pressure from a number of the fighter pilots in Korea to strip the fighter airplanes, in an effort to improve their acceleration and ceiling. There was criticism of the American designer for providing "excessive complexity" in such things as dual flying controls, ejection seats, parking brakes, and a host of other elements. While it is easy to overload an airplane with equipment which does not pay its way, many of the things complained about have amply proven their value in both peacetime and wartime operation. It is not easy to get a true answer regarding the comparative values of the stripped and unstripped airplanes. This can be done only by completely designing two airplanes, to take full advantage of every ounce of weight removed, and then evaluating the resulting performance. For instance, when 100 pounds of equipment are removed from the airplane, one must also remove at least 1-1/2 square feet of wing area, corresponding tail area, reduce the fuel for a given job, etc., through the complete design. Figures 4 to 8 show a typical study along these lines, removing various items of equipment and finally arriving at a smaller airplane, to show the total gains involved from the stripping procedure. In any such evaluation,

BASIC

WING AREA _____ 360 SQ. FT.
WING SPAN _____ 30 FT.
LENGTH _____ 65.4 FT.
POWER PLANT _____ YJ-67-W-1
TOTAL FUEL _____ 1530 GALS.
GROSS WEIGHT _____ 31,850 LBS.

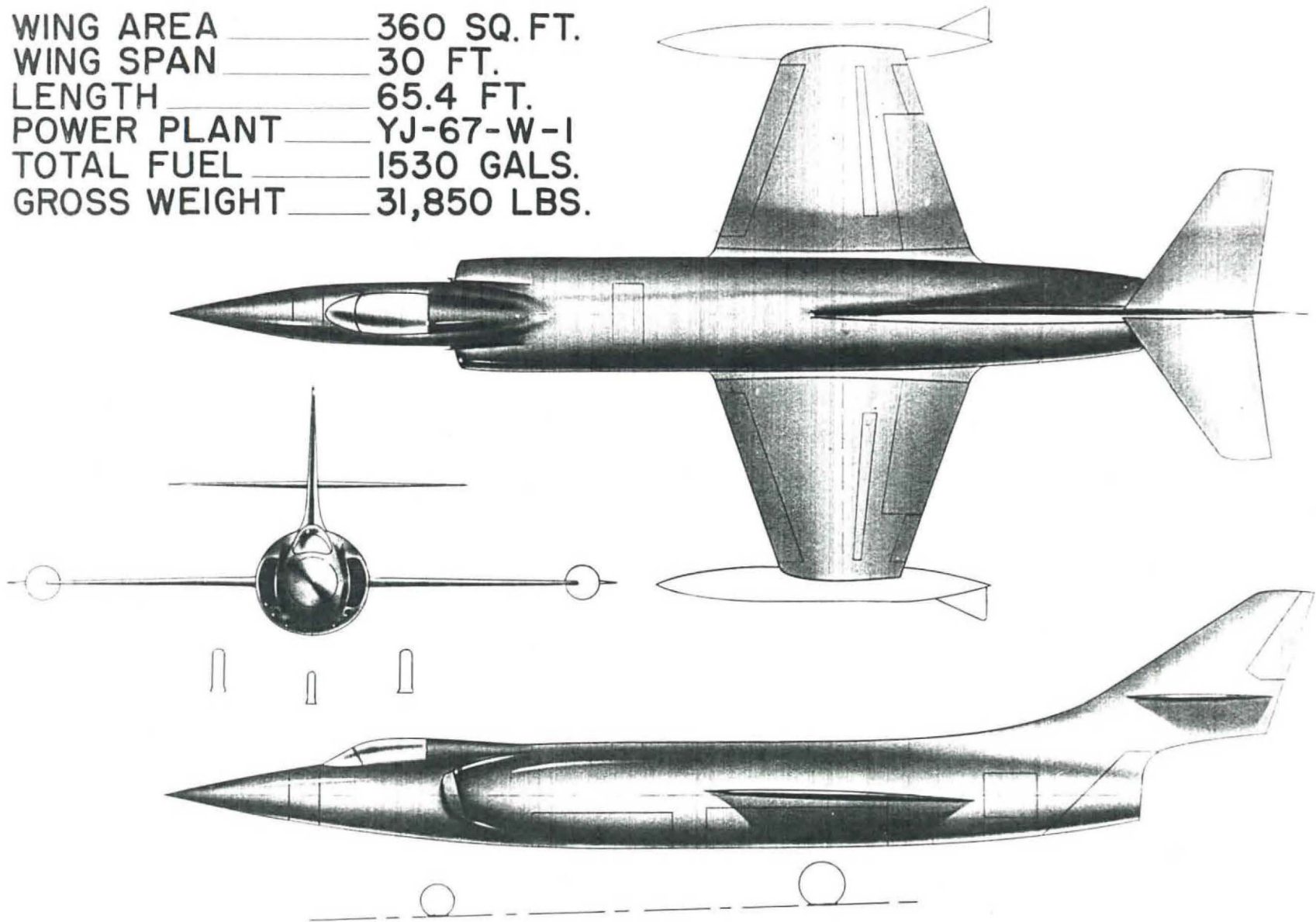

FIG. 4

EFFECT OF REDUCTION IN ARMAMENT & EQUIPMENT ON AIRPLANE GROSS WEIGHT

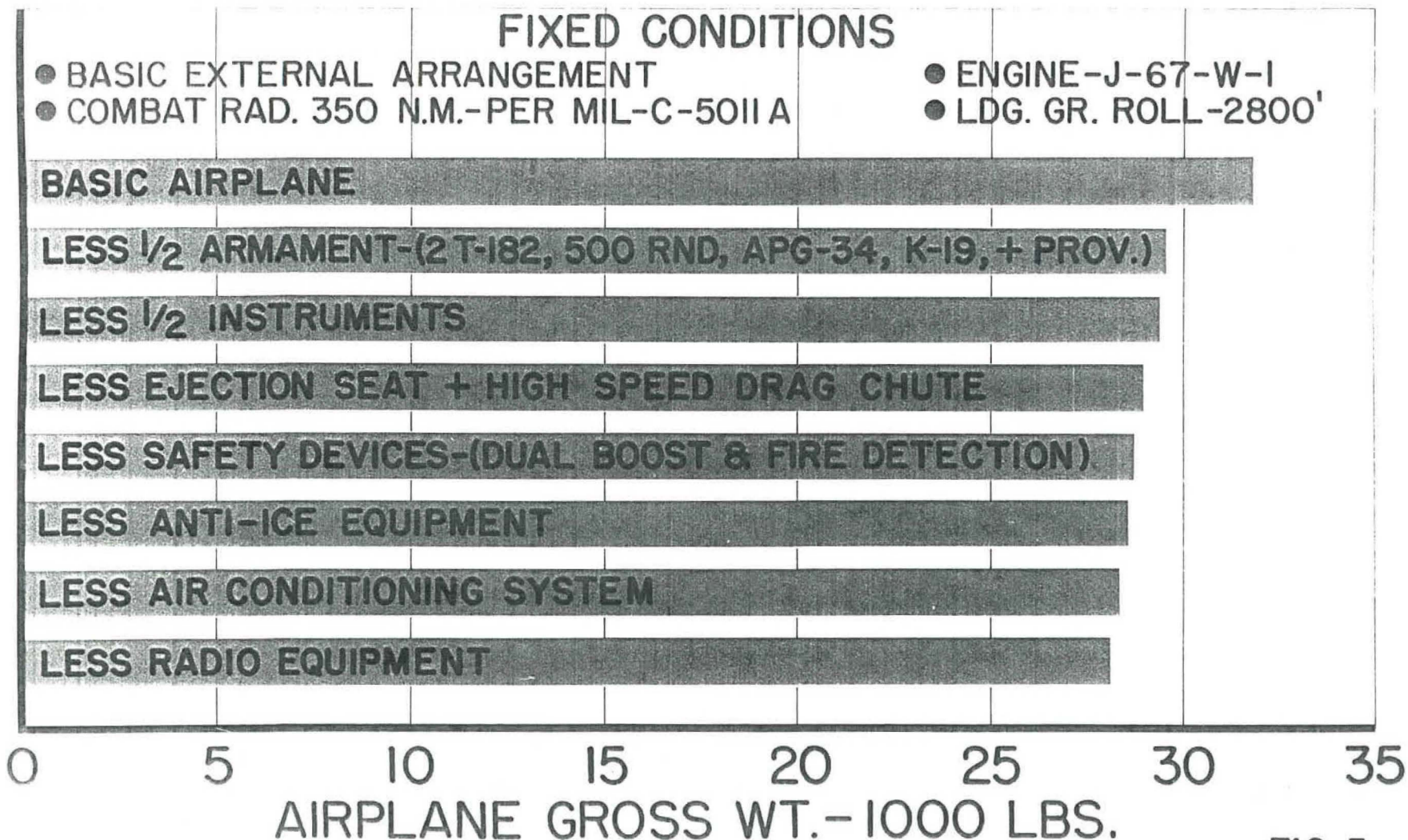

FIG. 5

MINIMUM EQUIP. BASIC

WING AREA _____ 306 SQ. FT.
WING SPAN _____ 27.7 FT.
LENGTH _____ 65.4 FT.
POWER PLANT _____ YJ-67-W-1
TOTAL FUEL _____ 1460 GALS.
GROSS WEIGHT _____ 28,100 LBS.

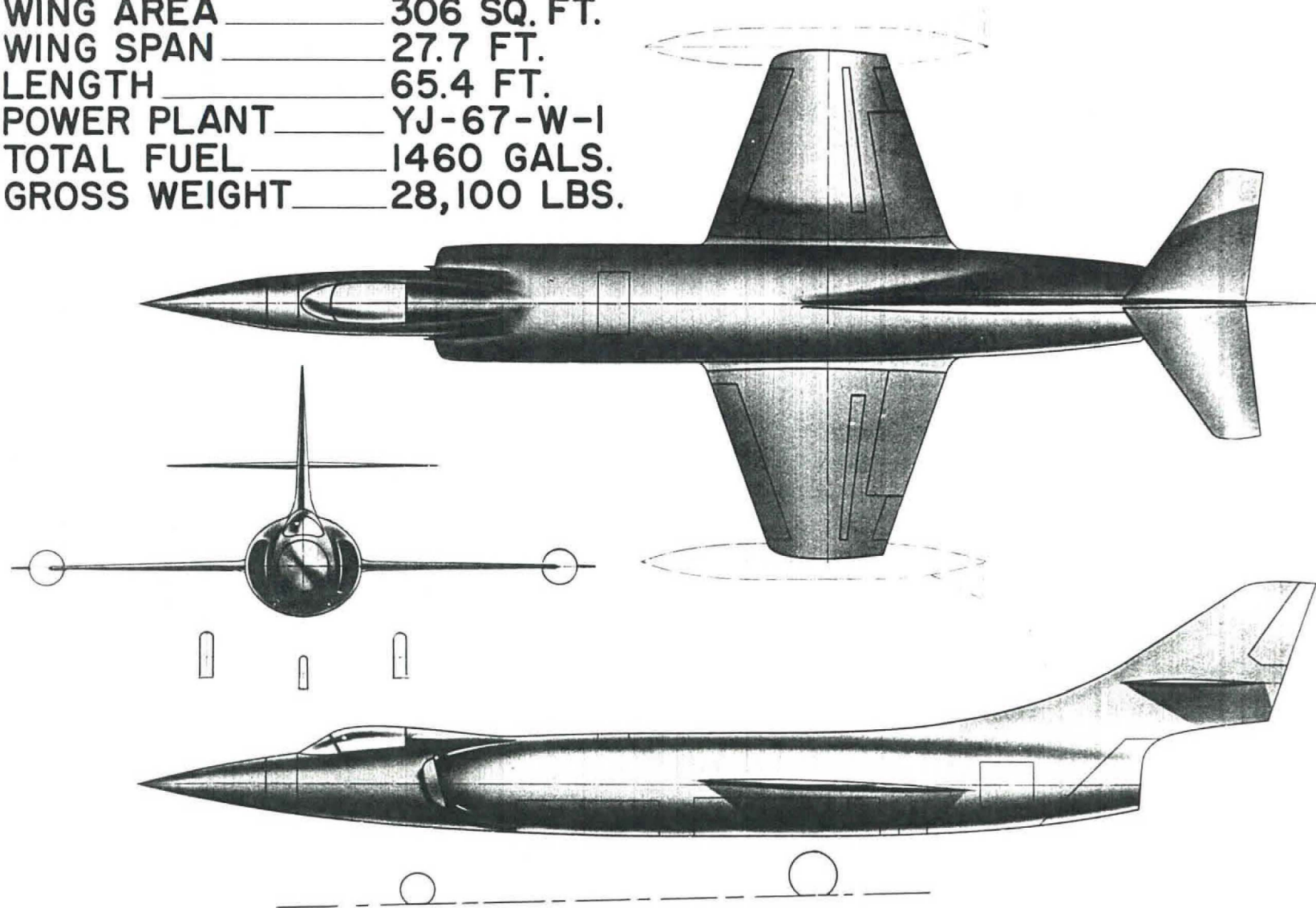
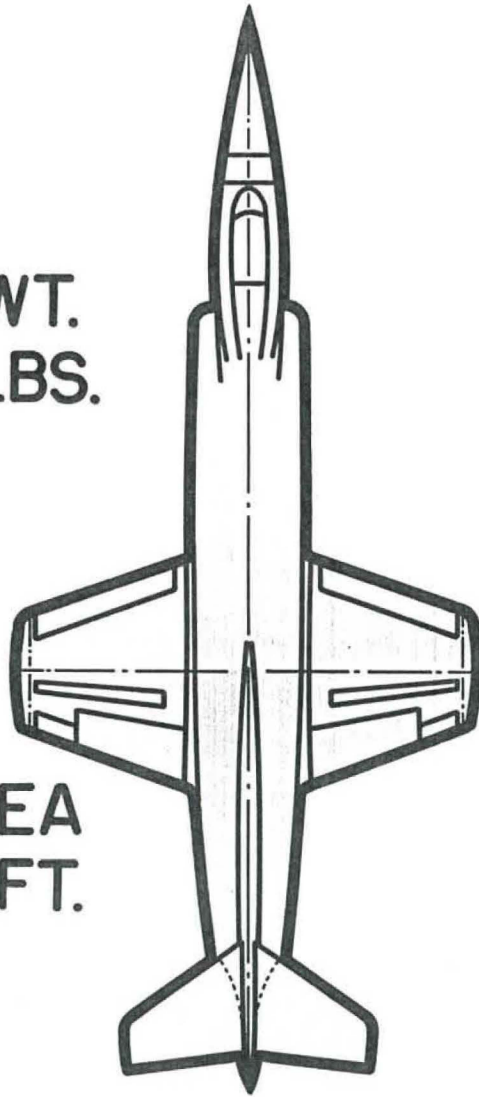

FIG. 6

COMPARATIVE PLAN

GROSS WT.
28,100 LBS.



WING AREA
306 SQ. FT.

GROSS WT.
31,849 LBS.

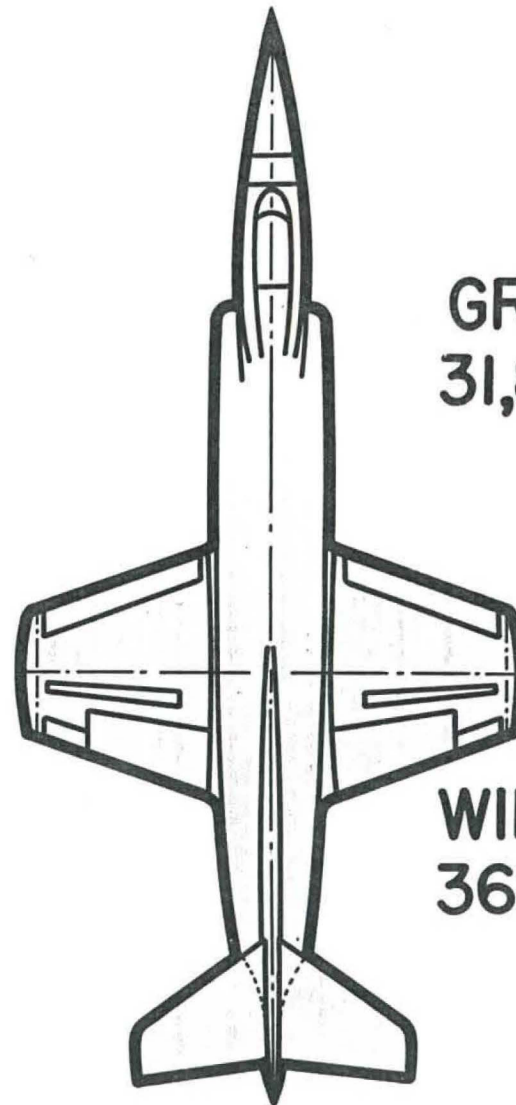

WING AREA
360 SQ. FT.

FIG. 7

SUMMARY OF FIGHTER STUDY

AIRPLANE _____	BASIC _____	STRIPPED _____
ARMAMENT _____	FULL _____	REDUCED _____
EQUIPMENT _____	FULL _____	MINIMUM _____
POWER PLANT _____	J-67-W-1 _____	J-67-W-1 _____
ARMAMENT		
GUNS: NUMBER AND TYPE _____	4 T-182 _____	2 T-182 _____
ROUNDS OF AMMUNITION _____	800 _____	500 _____
SIGHT _____	K-19 _____	K-19 _____
RADAR _____	APQ-42 _____	APG-34 _____
WING AREA (SQ. FT.) _____	360 _____	306 _____
FUEL (GALLONS) _____	1,530 _____	1,460 _____
WEIGHTS (POUNDS)		
TAKE-OFF _____	31,850 _____	28,100 _____
COMBAT _____	28,330 _____	24,800 _____
LANDING _____	23,025 _____	19,030 _____
PERFORMANCE AT 35,000 FT.		
A/B POWER; COMBAT WEIGHT		
MAXIMUM SPEED (MACH NUMBER) _____	1.92 _____	1.94 _____
SPEED AFTER 3 MIN. ACCELERATION (MACH NO.) _____	1.83 _____	1.90 _____
RATE OF CLIMB (FT./MIN.) _____	15,800 _____	19,680 _____
RATE OF CLIMB AT SEA LEVEL (FT./MIN.) _____	43,200 _____	53,000 _____
COMBAT CEILING (R/C = 500 FT./MIN.)(FT.) _____	52,300 _____	55,000 _____
COMBAT RADIUS (PER MIL-C-5011A) (N.MI.) _____	350 _____	350 _____
TAKE-OFF GROUND ROLL (FEET)		
MILITARY POWER _____	3,720 _____	3,410 _____
A/B POWER _____	2,000 _____	1,833 _____
LANDING GROUND ROLL _____	2,800 _____	2,800 _____

FIG. 8

Lockheed AIRCRAFT CORPORATION

CALIFORNIA DIVISION

certain factors must be kept constant, and in this study the landing roll and the mission length were kept constant, as was the powerplant. We never have the luxury of using rubberized powerplants in actual aircraft designs, so within the above limits the data shown apply.

For the example study, the basic airplane weighed 31,849 pounds and had a wing area of 360 square feet. Removing half the armament, half the instruments, ejection seats, drag parachute, dual boosters, fire detection equipment, and various other elements, the airplane could be reduced to 28,100 pounds, with a wing area of 306 square feet. This includes the effect of reducing the structural and fuel weights to the maximum degree compatible with equivalent landing field lengths and mission radii. A performance summary on Figure 8 shows the minimum equipped airplane is only slightly faster than the one carrying its full complement of armament and equipment. Its combat ceiling is 2700 feet higher, and its ground takeoff roll 300 feet shorter. This indicates, in the writer's opinion, that the performance gains shown would not be worth sacrificing the equipment removed, considering the very extreme nature of the "stripping" involved in the example.

There was also considerable hue and cry about the fact that we tended to load up our airplanes with equipment to do many

~~CONFIDENTIAL~~

LR 12236
June 18, 1957

Lockheed AIRCRAFT CORPORATION

CALIFORNIA DIVISION

different missions with a given airframe and thereby compromised all basic missions. An actual investigation of the facts showed this to be untrue in many cases. If an airplane has basically good performance and flight characteristics, it is not difficult or costly in weight to provide the capability for doing a number of different missions. It is only the marginal airplane that gets into trouble on this basis. This is particularly true if the alternate mission capability can be considered in the initial design of the airplane and not patched on afterwards.

Lockheed AIRCRAFT CORPORATION

CALIFORNIA DIVISION

III. WEIGHT AND PERFORMANCE FACTORS

Some of the early problems encountered, and which still exist, have to do with such factors as definition of combat time and factors affecting acceleration from cruising to combat speed. It was evident at once that the higher the performance of the airplane the more it was penalized by having a fixed combat time. The fuel burned, for instance, for five minutes of combat at Mach 2 is substantially less than what it would be for five minutes at Mach 3 (Figure 9). Yet military specifications call for fixed combat times. Speed alone is not a measure of combat effectiveness. The time to accelerate from cruising speed to high speed is at least equally important. Practically all of our American engines today are limited at altitude to Mach numbers of 2 to 2.2. Level flight speeds are set by this factor and not the aerodynamic limits of the airplane - for our best fighters. The time to accelerate to these speeds, however, can be greatly different, and the only way in which the better fighters can exploit their performance is by use of climbing maneuvers at their highest forward speed or by their ability to maintain their high speeds in turning flight.

A comparison of the fuel load breakdown for a subsonic

TOTAL COMBAT FUEL REQUIREMENT vs COMBAT MACH NUMBER

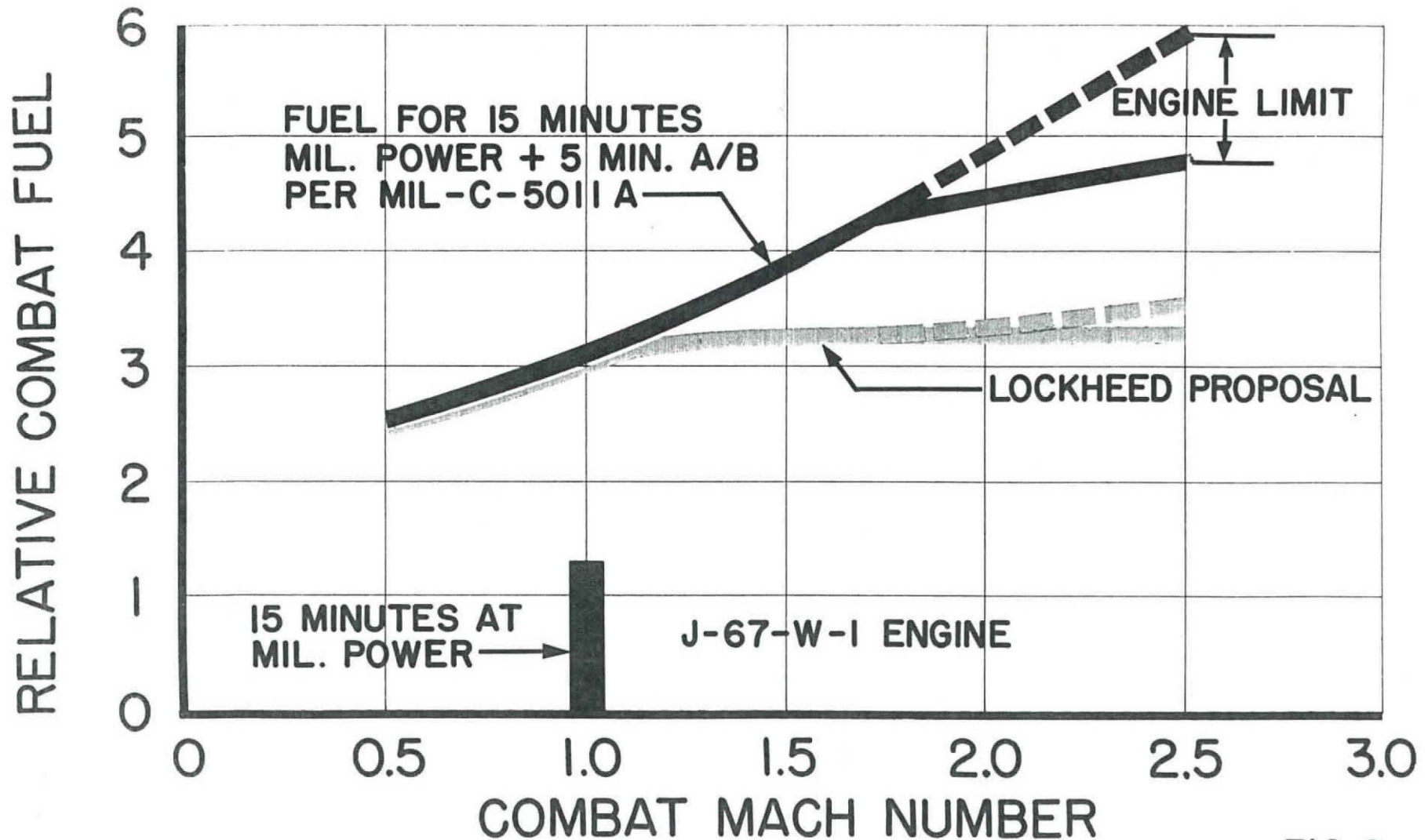

FIG. 9

~~CONFIDENTIAL~~
Lockheed AIRCRAFT CORPORATION

CALIFORNIA DIVISION

and a supersonic airplane is shown in Figure 10. It will be seen that the combat fuel is a substantially greater portion of the weight of a supersonic fighter than of a subsonic one. In our early studies, in order to keep airplane size reasonable and not compromise the faster airplanes with unnecessary fuel loads, a variation of combat time against speed was proposed and given certain consideration by the Air Force (Figure 11). Such arbitrary establishment of time at high speed, however, and its effect on airplane design condition, needs further evaluation at the present date.

The supersonic airplane is very critical in its combat radius, should a pilot continue combat at high speeds too long. Figures 12 through 15 show how the pilot can use up his total reserves under various conditions and easily exceed his safe combat radius.

A number of generalized studies on both large and small fighters was undertaken to evaluate such things as the effect of armament load on airplane gross weight to do a given mission, the effect of extending the combat radius, and the effect of changing the landing ground roll (Figures 16, 17 and 18). I would like to repeat that we consider the landing ground roll to be a fundamental factor in controlling supersonic aircraft design, because the landing characteristics of all our latest fighters require close judgment on the part of the pilot in his flareout procedure

COMPARISON OF FUEL LOAD FOR FIGHTER MISSION

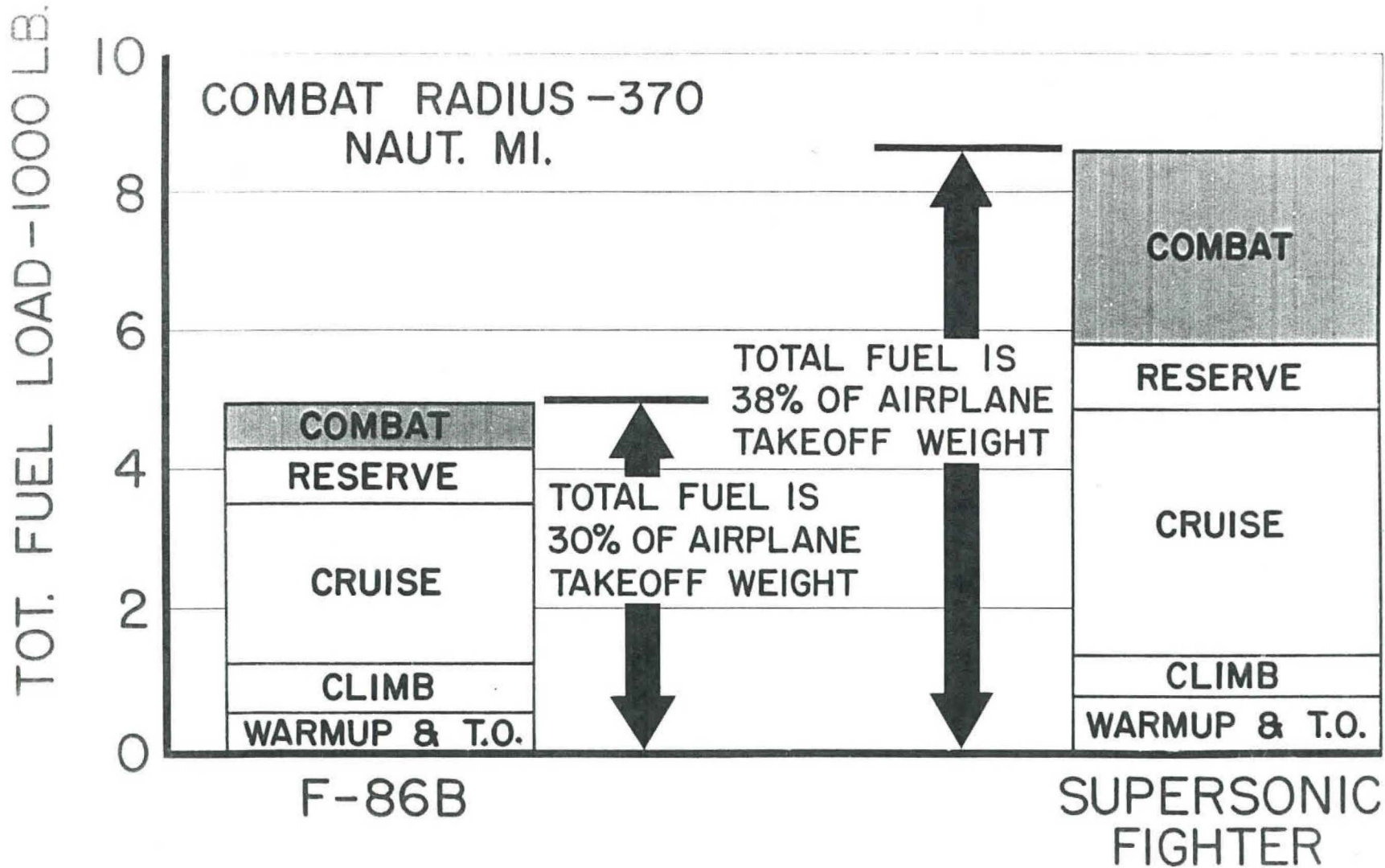

FIG. 10

PROPOSED AFTERBURNER COMBAT TIME FOR FIGHTER AIRCRAFT

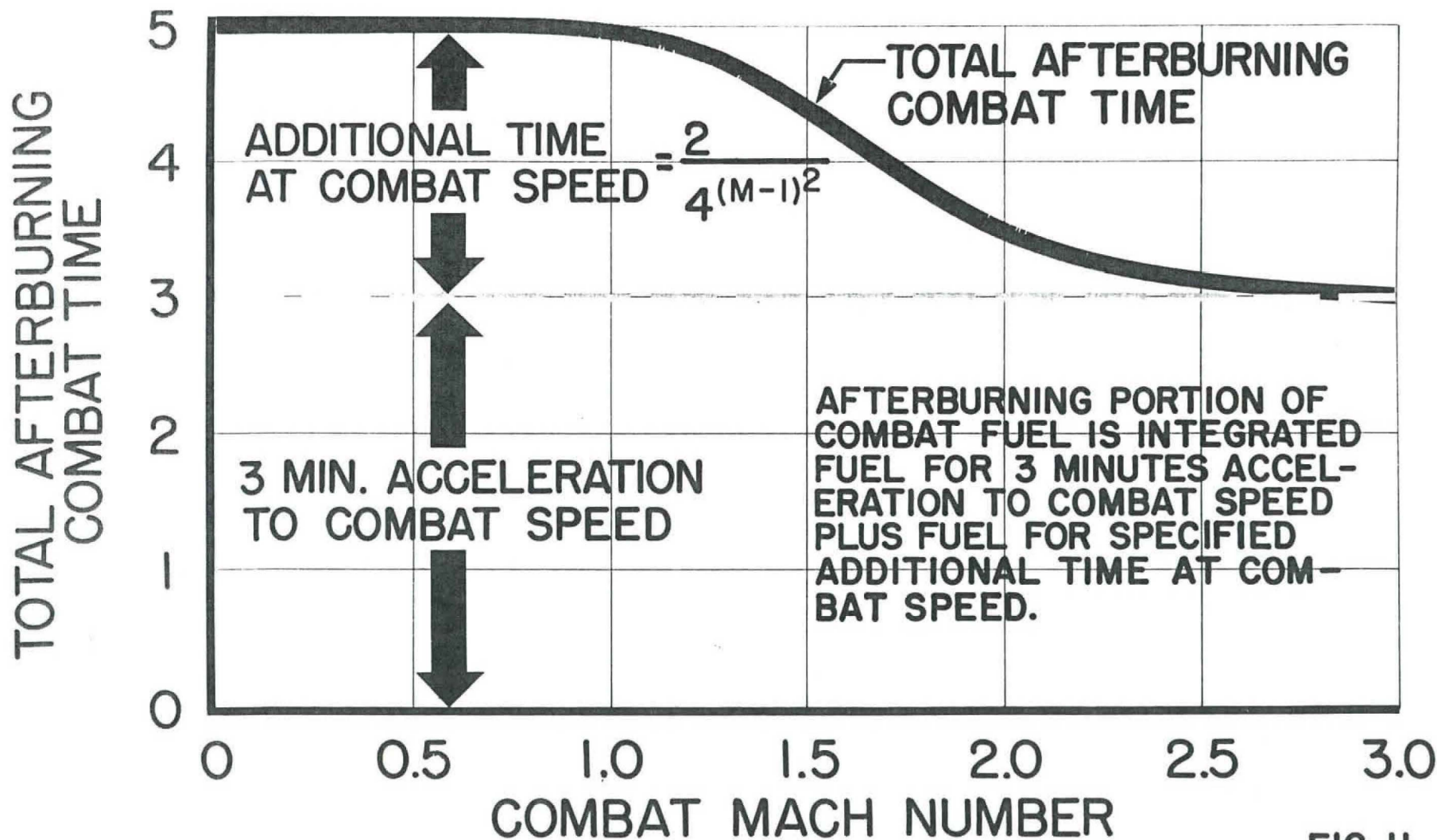
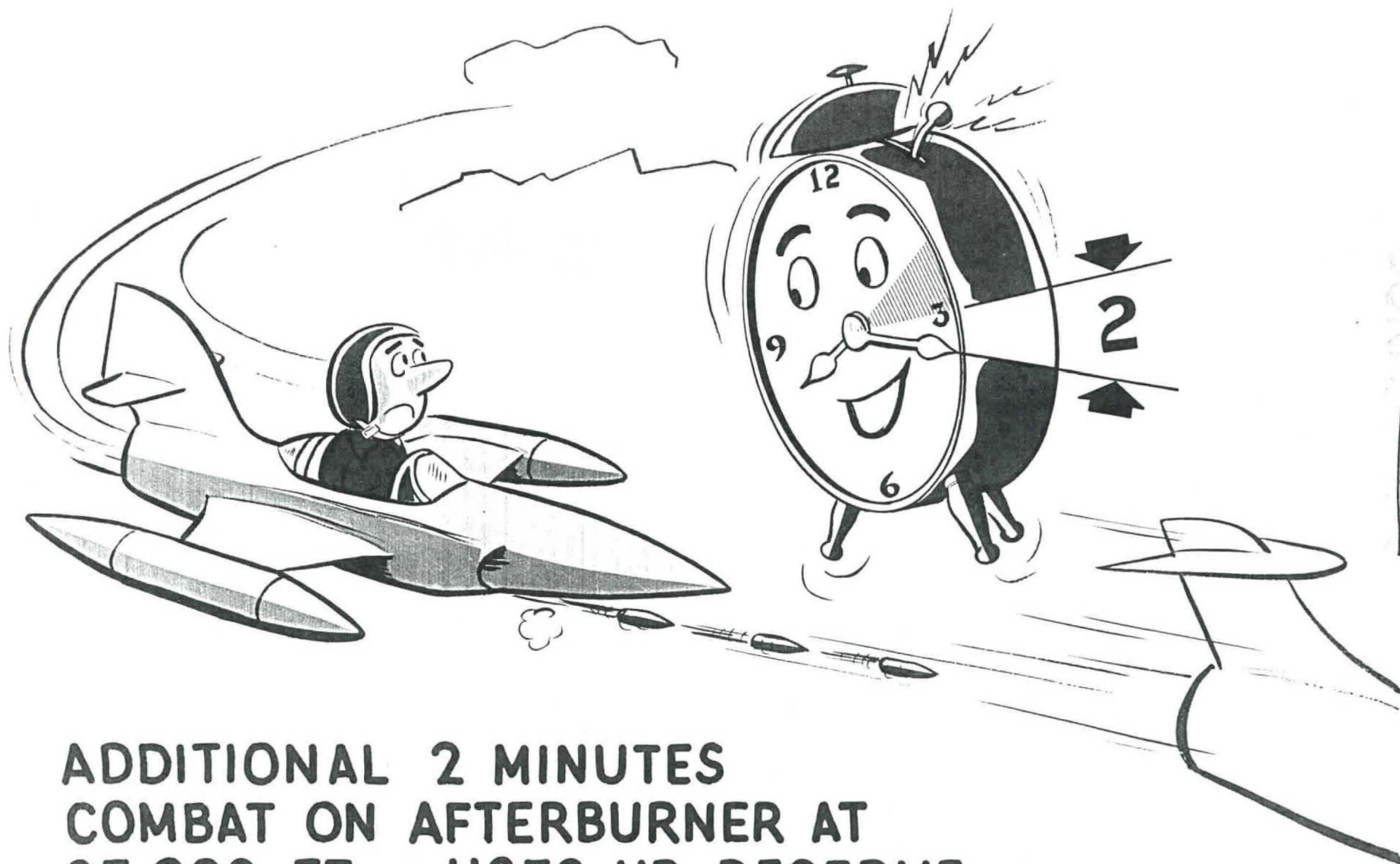

FIG. II

COMBAT TOLERANCE PERMITTED BY RESERVES...



**ADDITIONAL 2 MINUTES
COMBAT ON AFTERBURNER AT
35,000 FT. - USES UP RESERVE**

COMBAT TOLERANCE PERMITTED BY RESERVES...

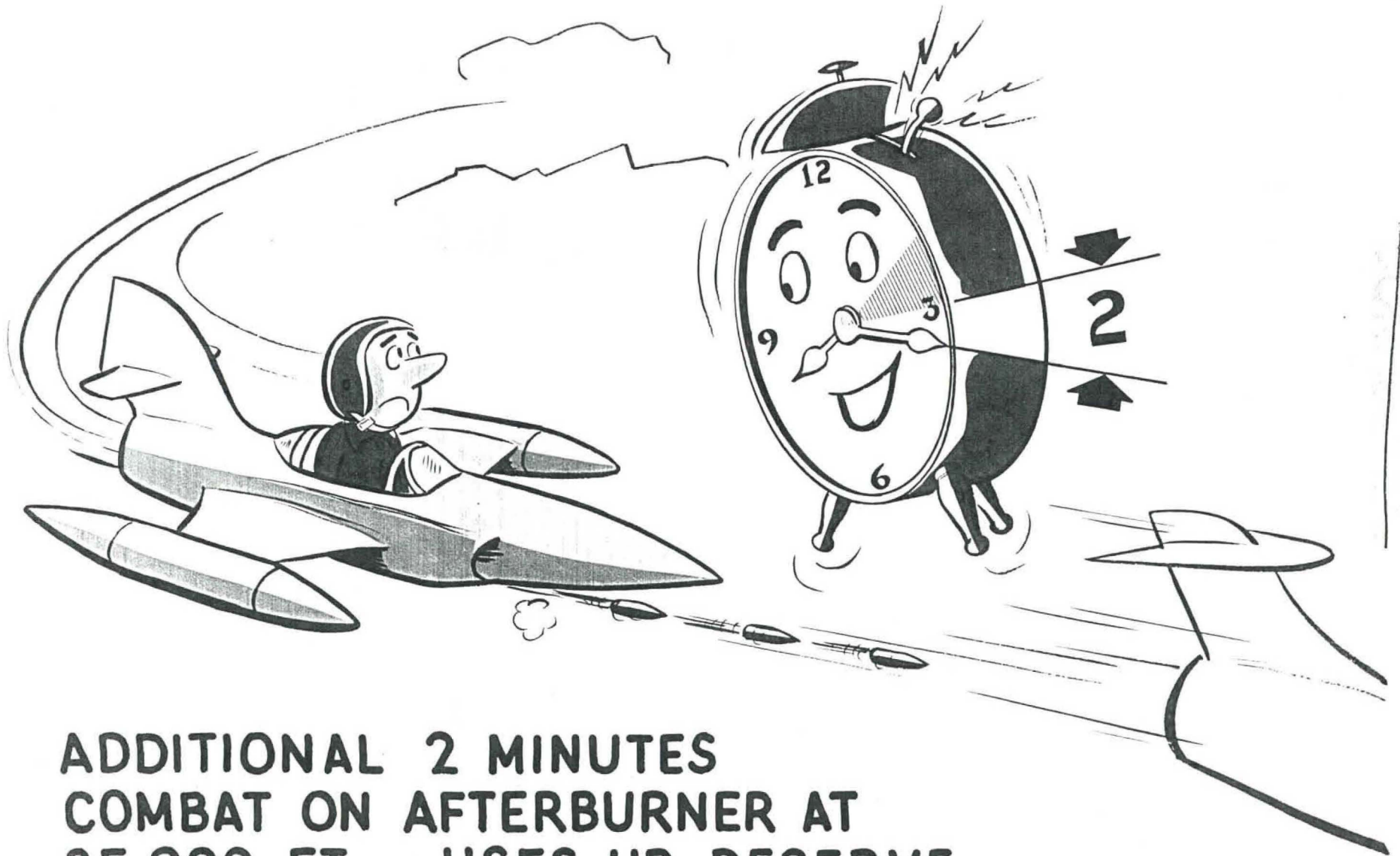

**ADDITIONAL 2 MINUTES
COMBAT ON AFTERBURNER AT
35,000 FT. - USES UP RESERVE**

COMBAT TOLERANCE PERMITTED BY RESERVES...



**SUFFERS BATTLE DAMAGE TO EXTENT
OF 15% DRAG INCREASE - PRESSURE LOSS
FORCES RETURN FLIGHT AT 15,000 FT.**

COMBAT TOLERANCE PERMITTED BY RESERVES...

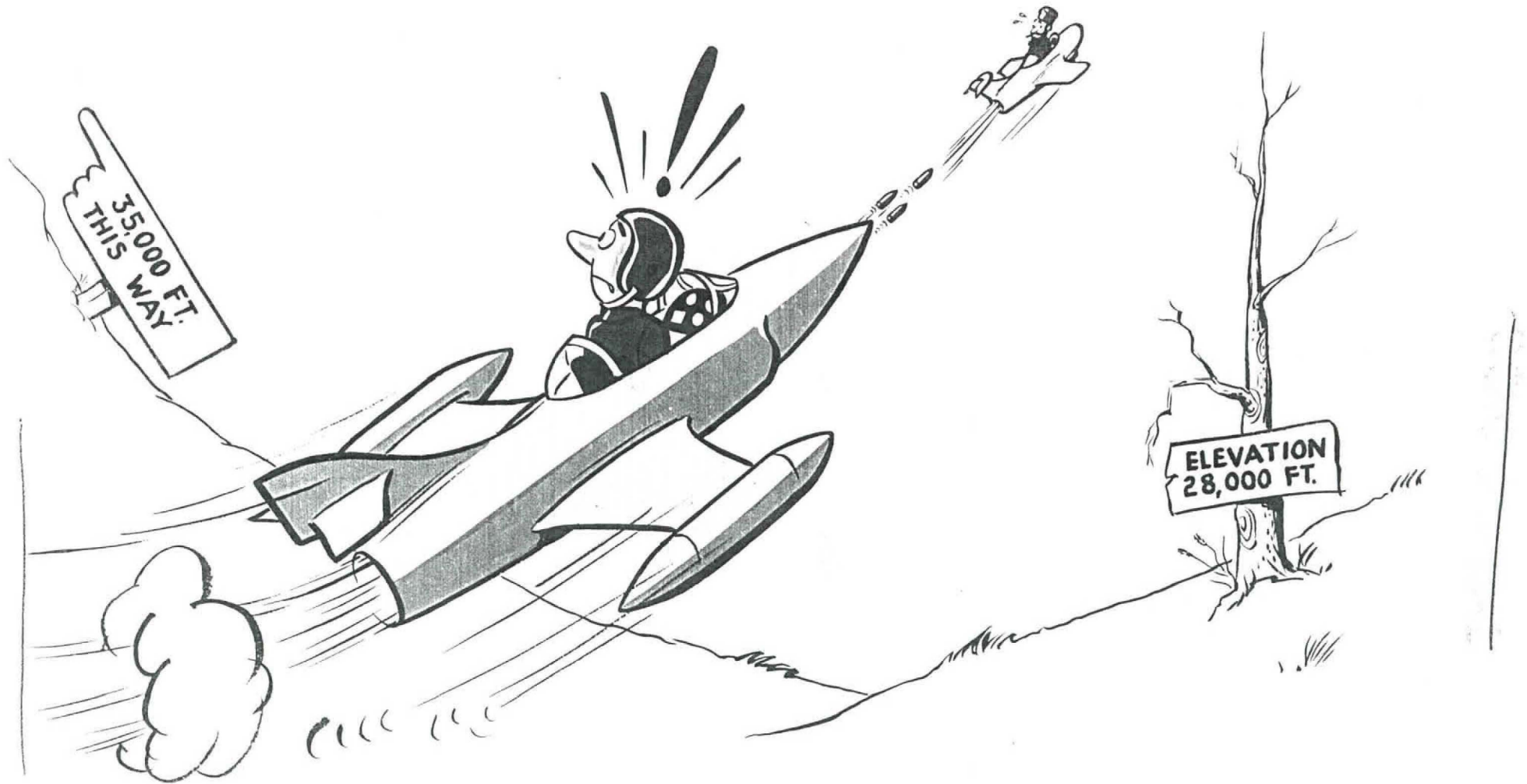

**COMBAT AT 28,000 FT. INSTEAD
OF 35,000 FT. - USES UP RESERVE**

COMBAT TOLERANCE PERMITTED BY RESERVES...



**CRUISING BACK ADDITIONAL DISTANCE
TRAVELED IN COMBAT - USES UP RESERVE**

AIRPLANE GROSS WEIGHT vs ARMAMENT LOAD

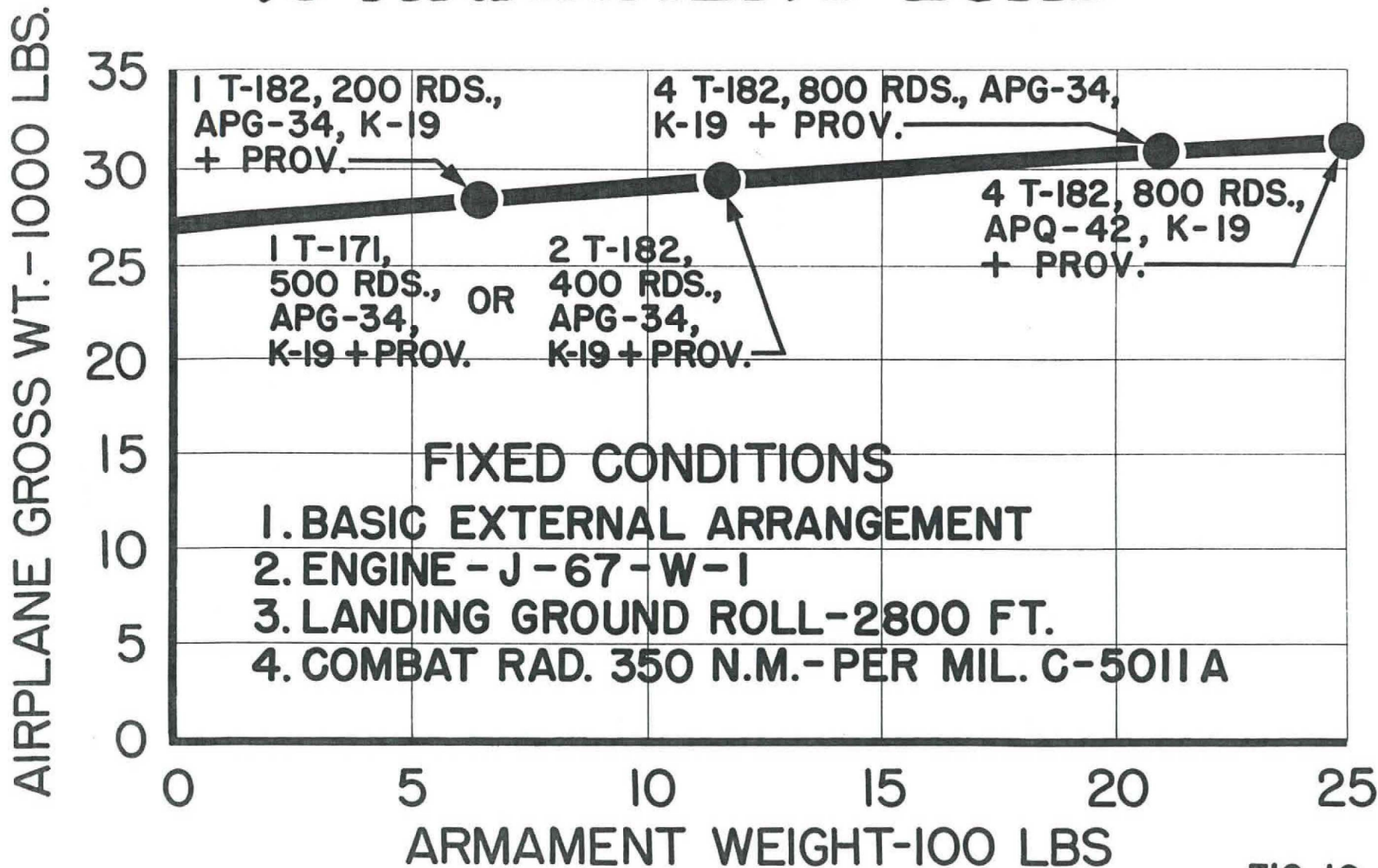

FIG. 16

AIRPLANE GROSS WEIGHT vs MIL-C-5011A COMBAT RADIUS

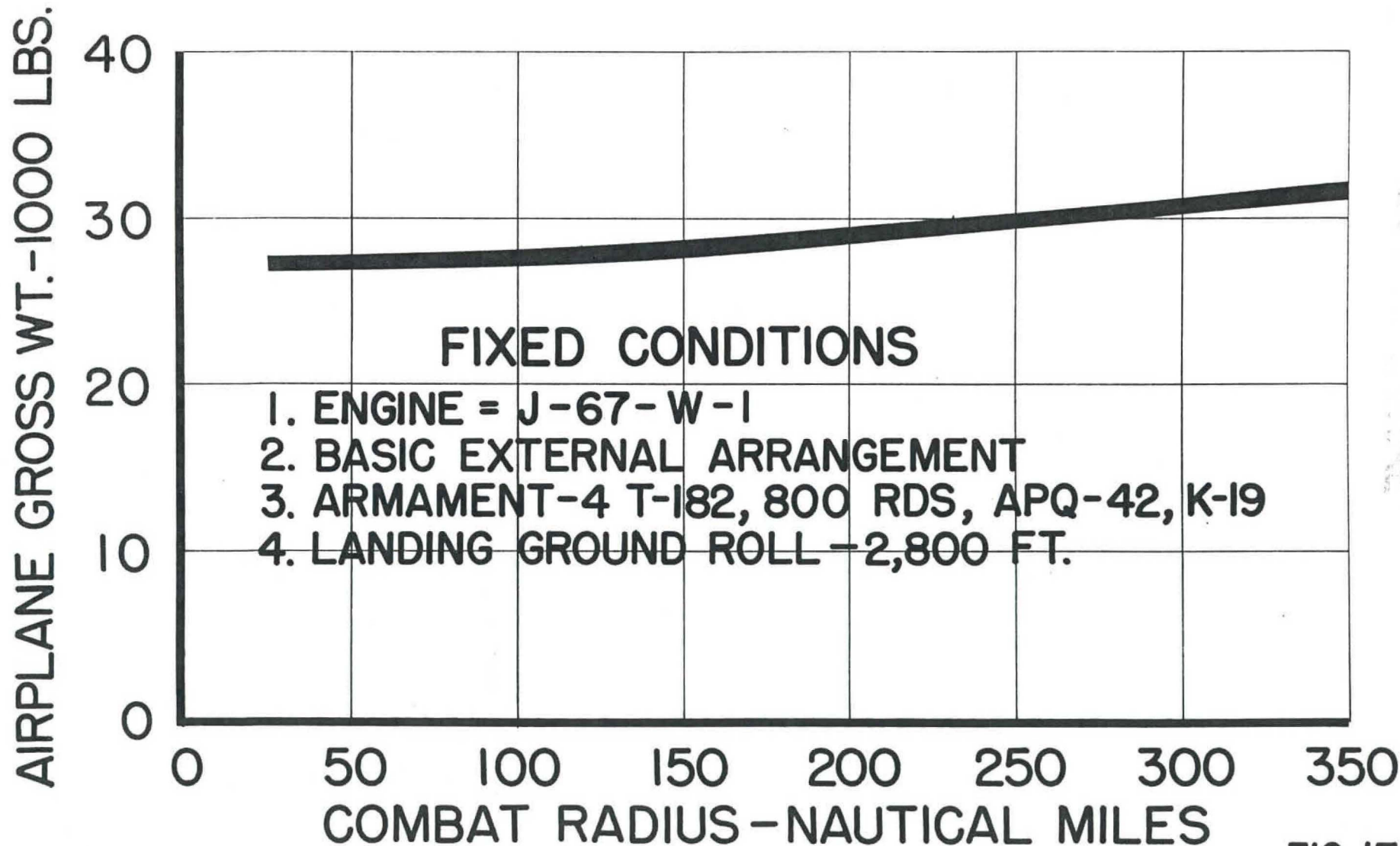

FIG. 17

EFFECT OF LANDING GROUND ROLL ON AIRPLANE GROSS WEIGHT

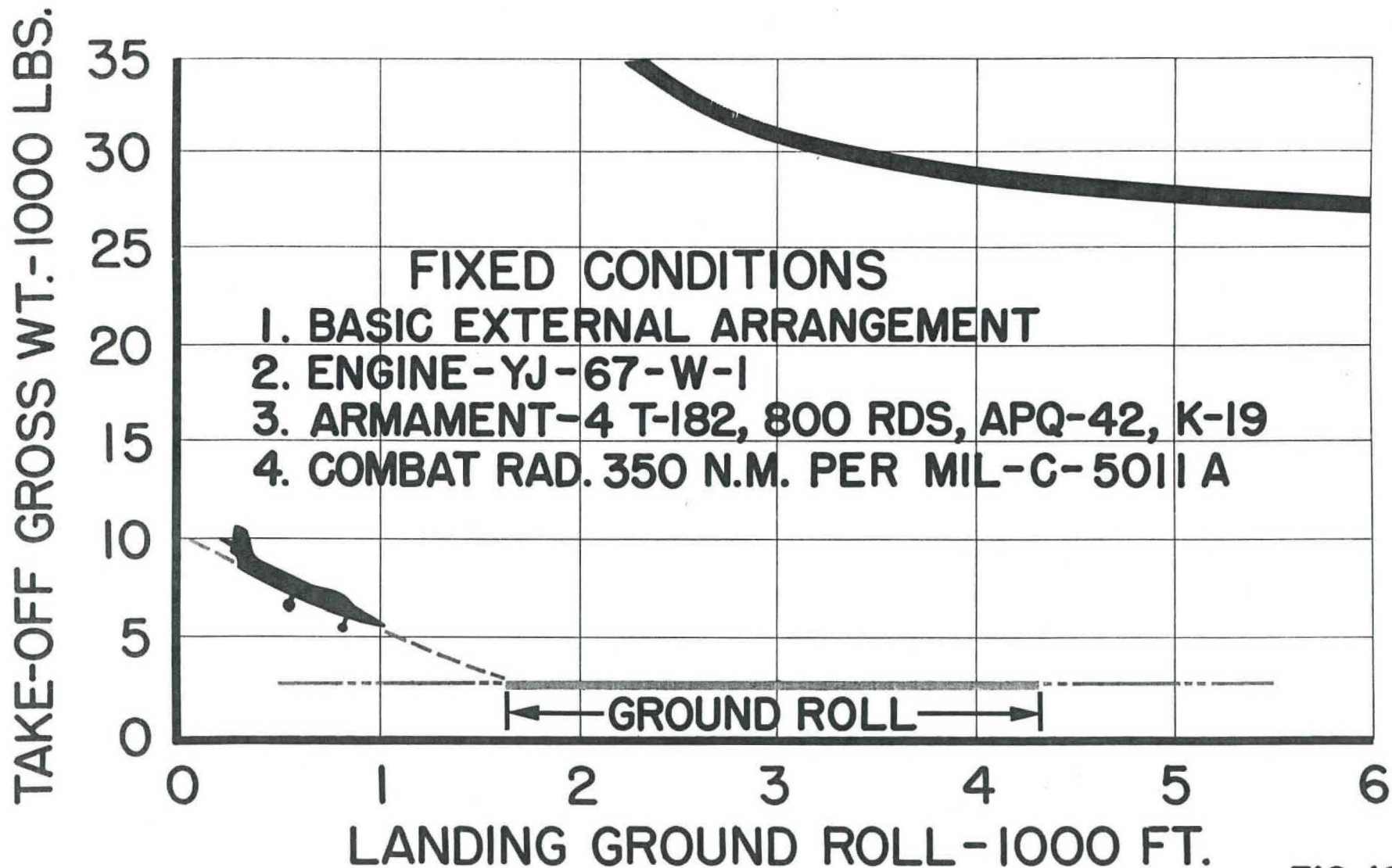

FIG. 18

EFFECT OF LANDING GROUND ROLL ON AIRPLANE GROSS WEIGHT

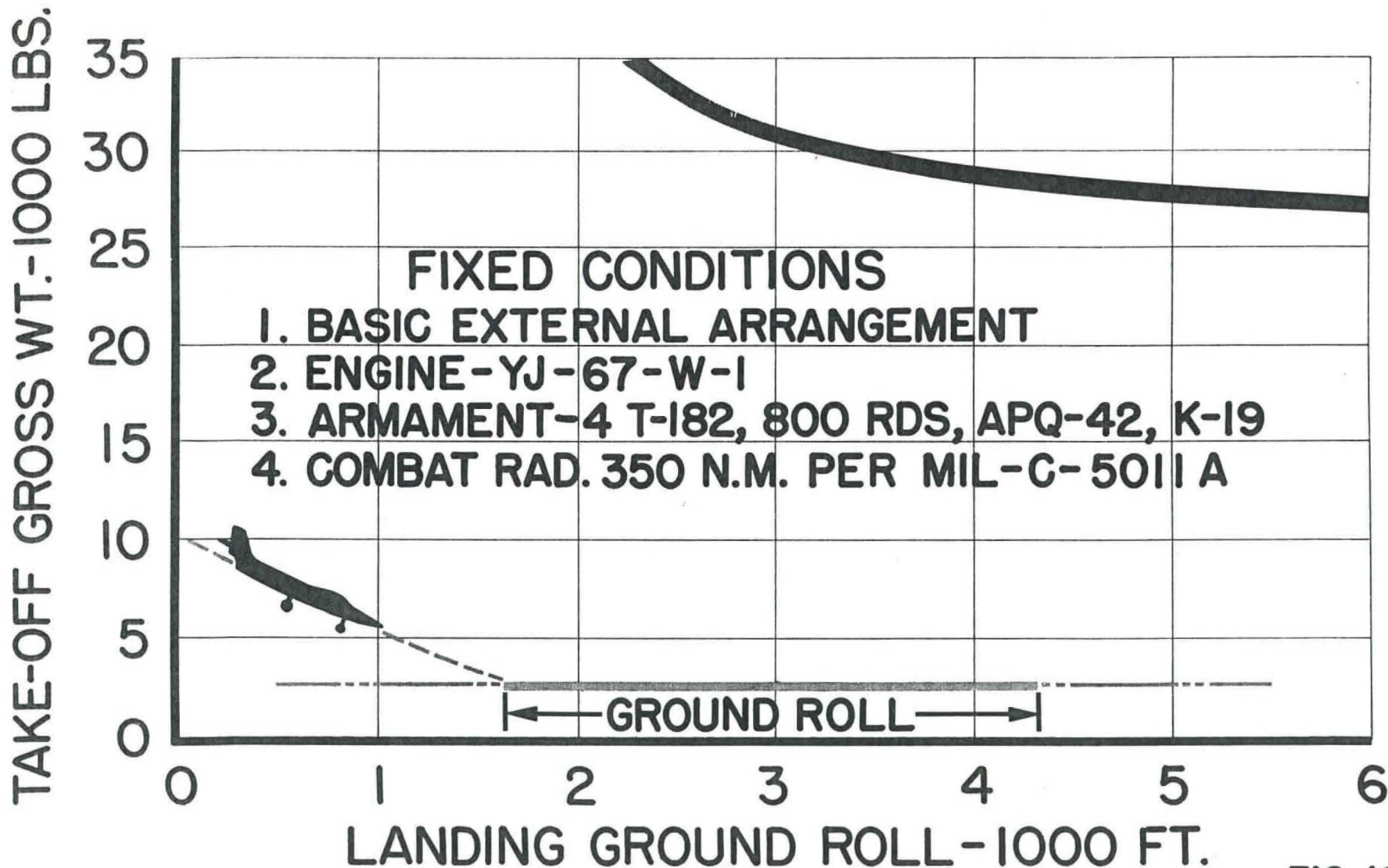

FIG. 18

~~CONFIDENTIAL~~

LR 12236
June 18, 1957

Lockheed AIRCRAFT CORPORATION

CALIFORNIA DIVISION

and, while excellent performance in terms of test numbers can be obtained for the landing roll (with the use of a great deal of braking, drag chutes, etc.), it is this factor under emergency conditions which will set up the field lengths required for operating supersonic fighters. While these early studies did not apply directly to the F-104, they are of interest for background material.

Lockheed AIRCRAFT CORPORATION

CALIFORNIA DIVISION

IV. DEVELOPMENT OF THE XF-104

After many discussions with the Air Force along the lines indicated above, a proposal to build a lightweight, completely equipped fighter was accepted in March 1953. The design aim was to produce a supersonic fighter that would have a performance capability in excess of Mach 2 and combat altitudes of over 60,000 feet. This performance could not be expected with the initial engine installation - the Wright J65 - but could be exceeded with the General Electric J79. It was necessary to use the latest form of armament, consisting of the T-171 (the so-called "Gatling gun"), which was the equivalent of four to six older type 20 mm guns but which was substantially lighter and more compact. It was evident that major steps must be taken in the provisions for advanced radar and gunsights.

Making use of the Lockheed "Special Project" approach to the fast development of prototypes, the XF-104 was designed, built and flown in 355 days. During this period, there were extensive wind tunnel tests run in our own and many NACA wind tunnels.

In laying out the basic arrangement, the writer proposed a symmetrical design for the attachment of the wings to the ducts and the

~~CONFIDENTIAL~~

LR 12236
June 18, 1957

Lockheed AIRCRAFT CORPORATION

CALIFORNIA DIVISION

ducts to the fuselage. It seemed evident that this form would give minimum drag while providing other arrangement advantages such as better clearance for the wing tip tanks and ability to carry the inlet air ducts directly to the engine. With a wing span of only seven feet outside of the ducts, it was considered feasible to attach the wings to rings forming the outside contour of the duct without any normal carry-through structure. After several structural engineers threatened to commit suicide, it was eventually determined that this could be done without any undue wing weight or fuselage weight penalty. A basic drag reduction of some 12% appeared to result from the midwing approach compared to low wing designs. The decision to use a high horizontal tail position will be described more fully later in the paper.

One of the first problems that seemed apparent from the basic layout of the airplane was that the span of the vertical tail above the centerline of the fuselage was practically equal to the wing semi-span and with the high horizontal tail position the vertical tail was very effective. It was evident that the rudder was, therefore, a good aileron, and that adverse roll would occur with rudder deflection. This indicated some amount of negative dihedral or "cathedral" would be necessary, but it was difficult to determine the proper amount. At this time, the NACA at Ames Laboratory had modified a propeller-driven airplane to vary the lateral

~~CONFIDENTIAL~~
Lockheed AIRCRAFT CORPORATION

CALIFORNIA DIVISION

stability artificially by "black boxes," so that different apparent amounts of dihedral could be evaluated and pilots' opinions gathered on what was a desirable relation between dihedral effect and a given amount of directional stability.

A phone call to Mr. Smith J. DeFrance obtained his immediate concurrence in running a series of tests trying to simulate the desirable degree of cathedral which it would be necessary to employ for the F-104. Lockheed computed the characteristics required to simulate zero degrees, five degrees, and ten degrees cathedral, and Mr. Tony LeVier, our engineering test pilot, visited Ames to evaluate the problem on the NACA aircraft. He was not told in advance what angles of cathedral were to be simulated, but he was told by radio what settings to try on the "black box."

He was first given a setting of zero degrees dihedral, whereupon he said over the radio, "My God, what did you give me here?" The airplane was very difficult to fly. He was then given several other settings, with the result that a minus ten degrees was chosen to give good characteristics for the F-104 configuration. Throughout all phases of testing the F-104, such typical cooperation was obtained from the NACA.

A major problem in the concept of the airplane was the

~~CONFIDENTIAL~~
Lockheed AIRCRAFT CORPORATION

CALIFORNIA DIVISION

flutter and aeroelastic characteristics encountered with a 3% thick wing. This wing was only three-quarters as thick as the thinnest research wing, and about 82% as thick as those flown at that time on the X-7 test vehicle. There were many unknowns, and still are, in the prediction of flutter, particularly in the transonic speed range, as well as at supersonic speeds. It was necessary to find some cheap means of testing empirically various wing and tail configurations to insure freedom from flutter. It seemed that the use of 5-inch HVAR rockets might be appropriate, using camera means to obtain data of flutter, and a parachute for recovery of the camera. This study was actually undertaken prior to getting a contract on the XF-104, and was carried on initially for the larger fighters indicated in the early part of this paper, for which we had no Air Force contract.

When a private organization tries to go out and buy 5-inch rockets, they rapidly find out such armament cannot be purchased without government sanction. One day when the writer was visiting General ----- in Baltimore, he made the problem known to him. The General immediately turned to his aide and said, "Send a message to General ----- in Korea and tell him to stop shooting 5-inch rockets for one morning and send them to Kelly." By the time I returned to California, some four hundred odd 5-inch rockets had been delivered to Lockheed, for implementing studies of flutter. There was no red tape in that operation, until we found out

Lockheed AIRCRAFT CORPORATION

CALIFORNIA DIVISION

ourselves we lacked proper storage facilities for the rockets, an area in which to fire them, and several similar items. Edwards Air Force Base solved these problems by providing the necessary facilities.

A typical shot of the data obtained is indicated in the accompanying movie and slides (Figures 19 and 20). A group under Mr. Ford Johnston was able in a very short time to do some excellent basic research on the flutter of the F-104 configuration, including such factors as tip tanks and tails. One dollar in every eight spent on the XF-104 program was spent on flutter and aeroelastic problems. Later, the tail surfaces and aft fuselage were mounted on a sled and tested to high speeds on the Edwards Air Force Base sled facility. These precautions resulted in our having encountered no flutter problems on the aircraft to date.

The problem of flight controls was solved by the application of irreversible boosters on the stabilizer and ailerons, and various damper devices were evaluated for providing the optimum gun platform at all speeds. The basic stability of the airplane is so good that perfectly safe flight can be maintained without any of the yaw, pitch or roll dampers in operation. The use of these devices, however, gives the airplane superior stability and damping, which is no doubt necessary for effective use of any supersonic airplane as an effective armament platform.



CONFIDENTIAL

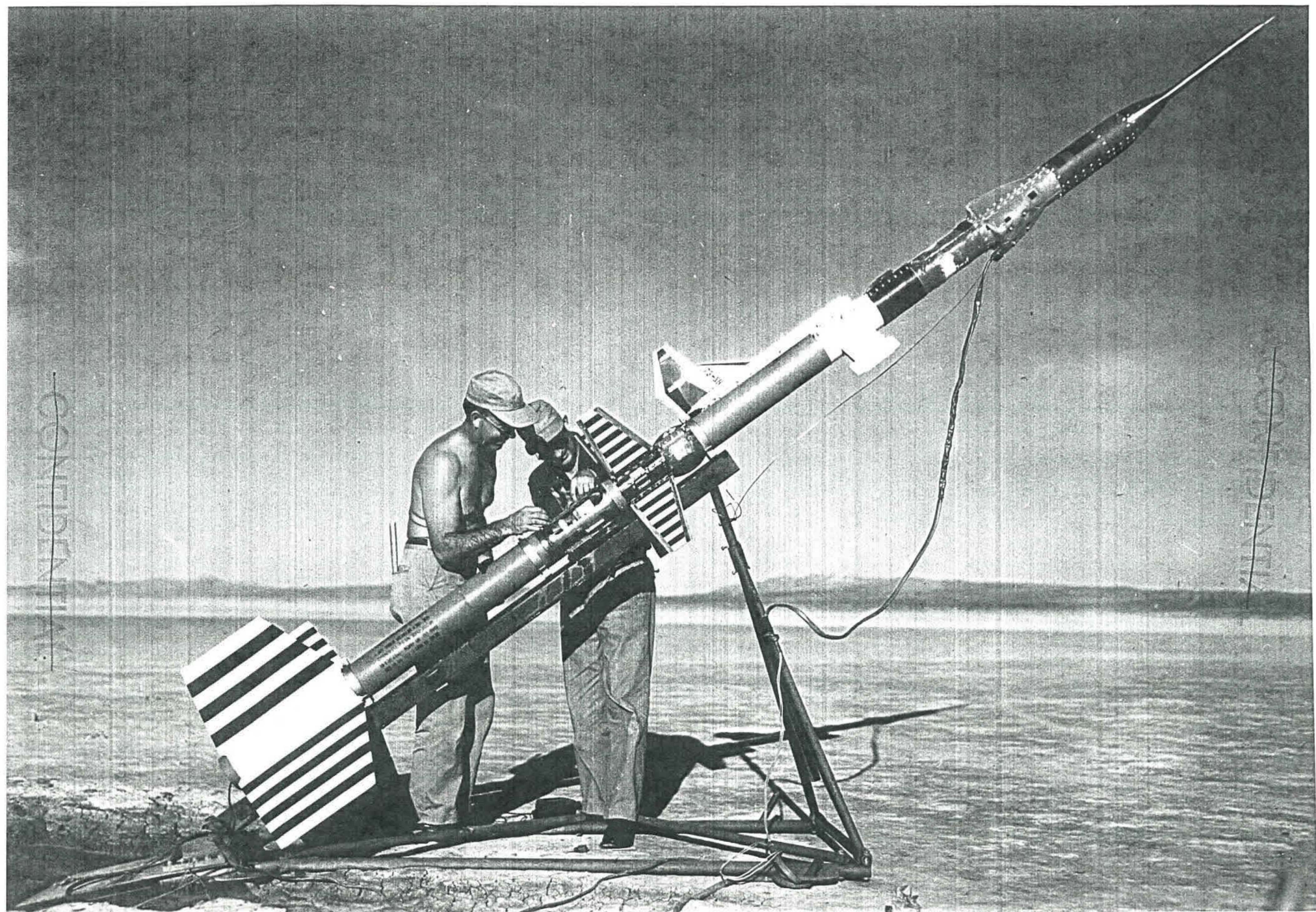

~~CONFIDENTIAL~~

LR 12236
June 13, 1957

Lockheed AIRCRAFT CORPORATION

CALIFORNIA DIVISION

An interesting problem developed in trying to fit an irreversible booster into the thin wing. This was solved by a "piccolo" design (Figure 21), involving multiple operating cylinders imbedded in what amounts to a solid piece of dural, which is practically a structural part of the airplane.

AILERON BOOSTER

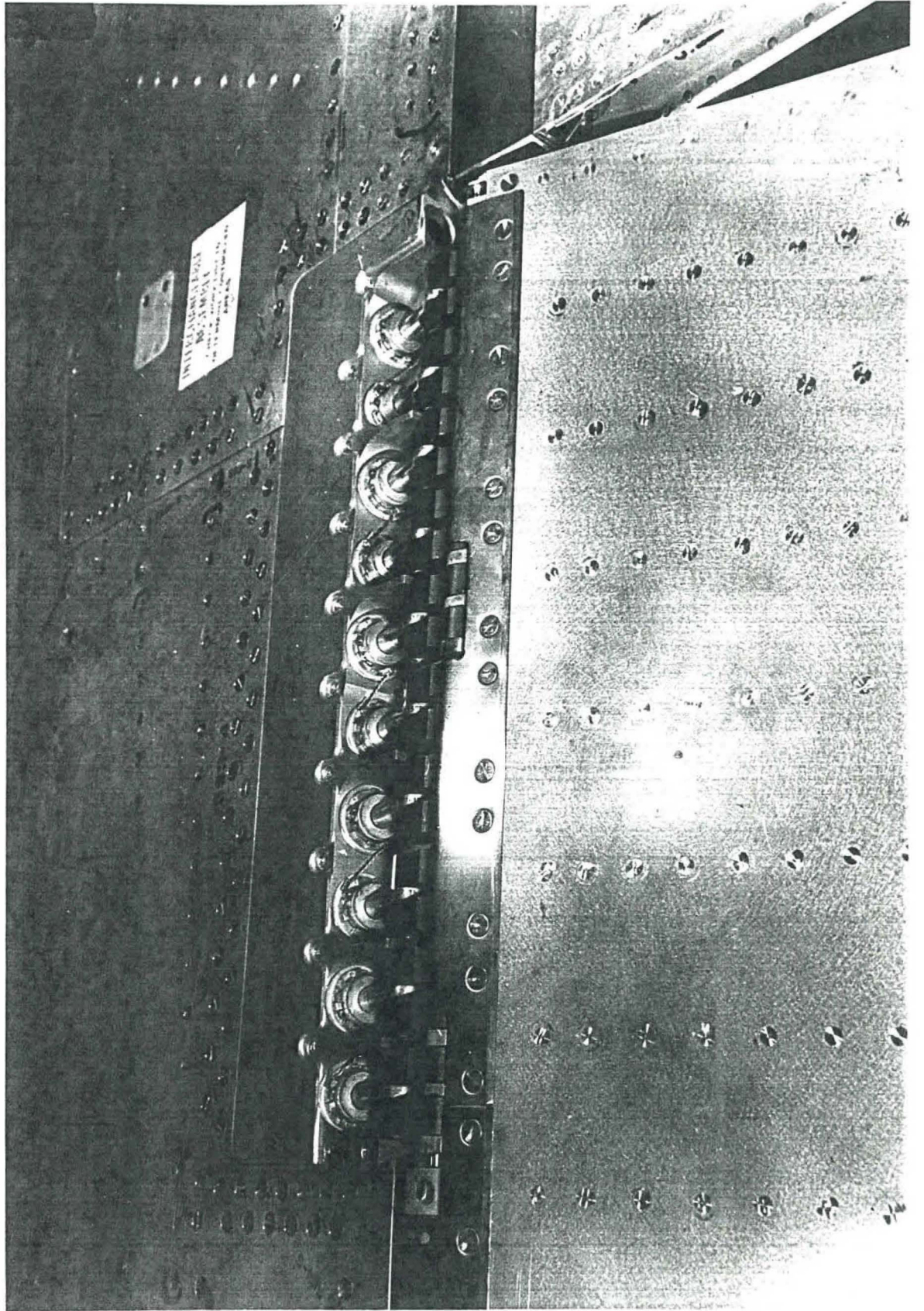

FIG. 21

~~CONFIDENTIAL~~
Lockheed AIRCRAFT CORPORATION

CALIFORNIA DIVISION

V. PRODUCTION STUDY PHASE

During the time the experimental airplanes were being built, a new approach was taken to the over-all problem of producibility. The rapid prototype development system does not always allow sufficient time for incorporation of desirable production features in the experimental airplane. A program was therefore proposed to the Air Force, and accepted, whereby for a sum of \$400,000, a producibility study for the production airplane would be made concurrently with development of the experimental aircraft. A special group of about 20 people, made up of production engineers and structural and cost analysis engineers, was set up in an area separate from the experimental group, and they were given duplicates of the prototype drawings as soon as these were released to the experimental shop. This group was given a directive to investigate the cheapest, lightest, and most maintainable form in which to produce each part of the production airplane, but were limited so that there would be no increase in weight or drag, and likewise no adverse maintenance features, compared with the experimental airplane. They were completely free to study any method of making the various aircraft components. The success of this study is very outstanding.

Prior to making the final production drawings, all phases of the producibility report were reviewed with engineering, tooling, and

~~CONFIDENTIAL~~
Lockheed AIRCRAFT CORPORATION

CALIFORNIA DIVISION

cost people, and the best specific design chosen for large scale production. In certain cases, as many as twenty alternative designs were evaluated. Methods of building the wing, for instance, included the use of castings, forgings, honeycomb structure, heavy plate structure with column supports, and many other variations. When the meeting was concluded, there was complete agreement on the part of the various groups involved that a good compromise had been reached between factors on performance, weight, and producibility. Examples of some of the test specimens developed and tested by the group are shown in Figures 22, 23 and 24. The changes incorporated into the production airplane as a result of this study will result in savings of the nature shown in Figure 25. For a reasonable run of production airplanes, it seems that a saving of from \$40 to \$70 will be obtained for each dollar spent in the study. The savings per airplane, including the effect of the learning curve on production efficiency, are of the nature of \$10,000 to \$12,000 per airplane as a result of this study alone.

This procedure seems to be an excellent way of taking full advantage of the fast prototype development system and still combining it with the most efficient type of production study at the lowest possible cost.

MODEL OF SKIN AND TRUSS-CORE ASSEMBLY

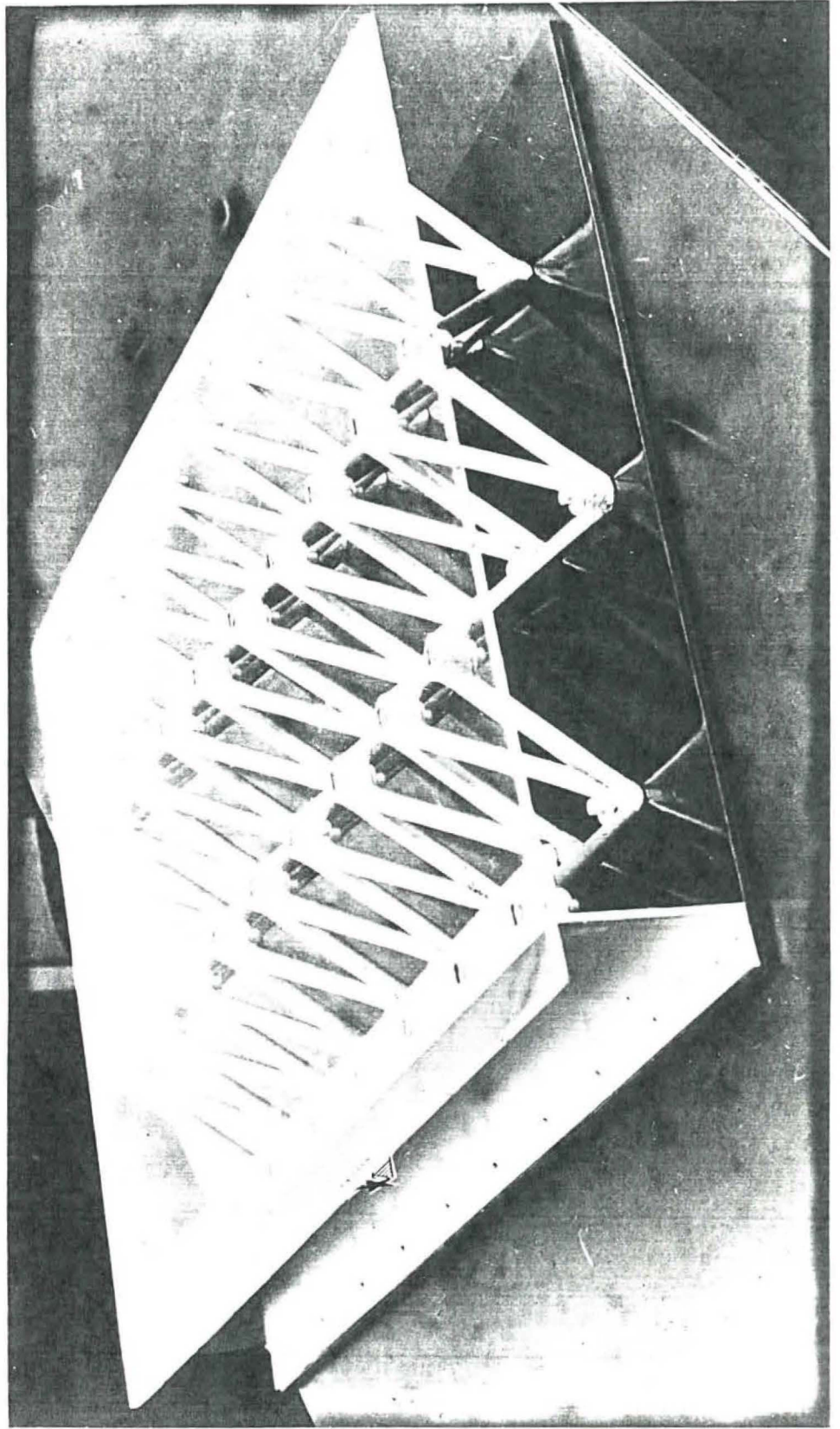

FIG. 22

BOX BEAM TEST

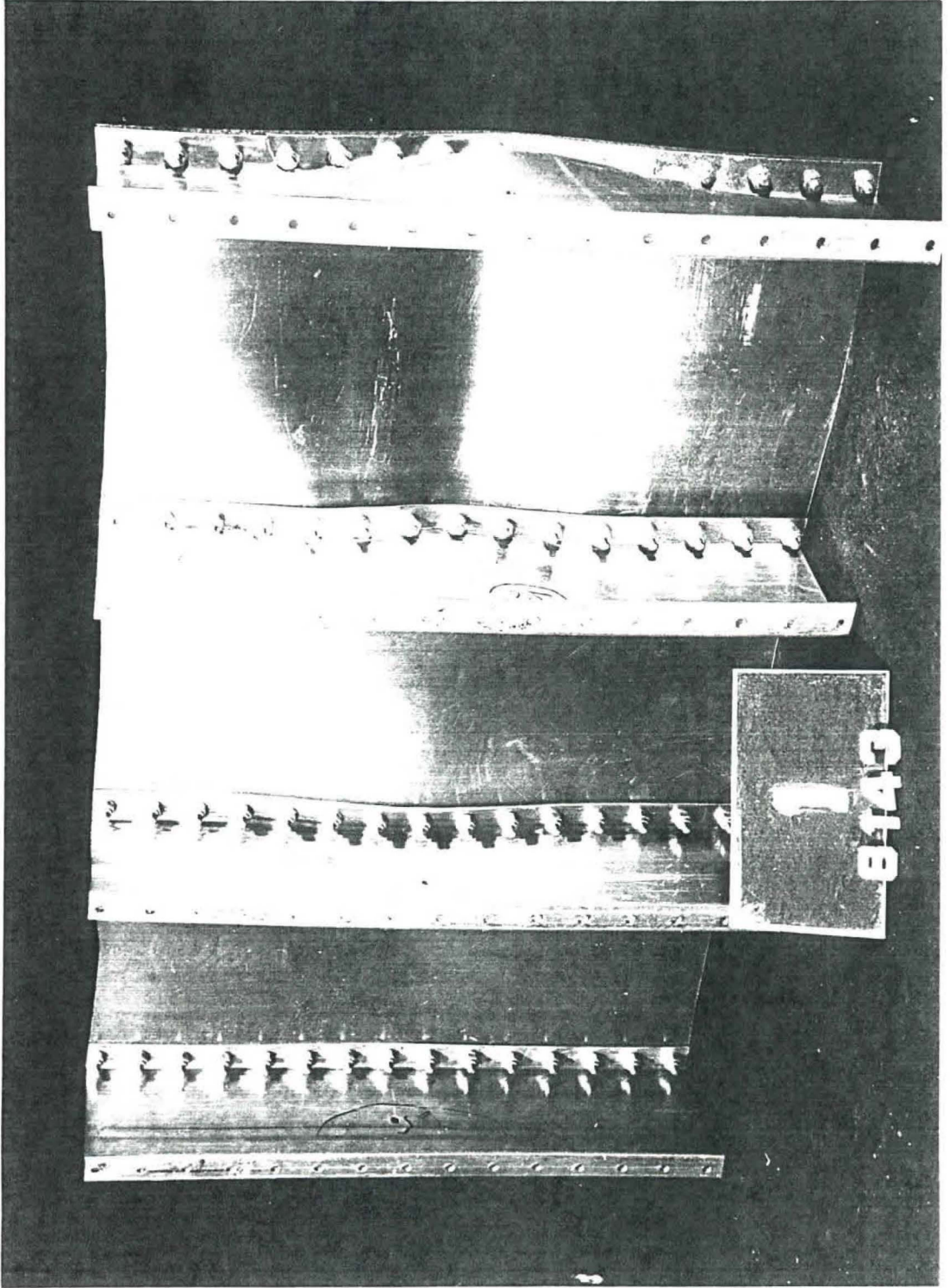

FIG. 24

SAVINGS REALIZED BY F-104 PRODUCIBILITY STUDY MADE DURING EXPERIMENTAL DEVELOPMENT

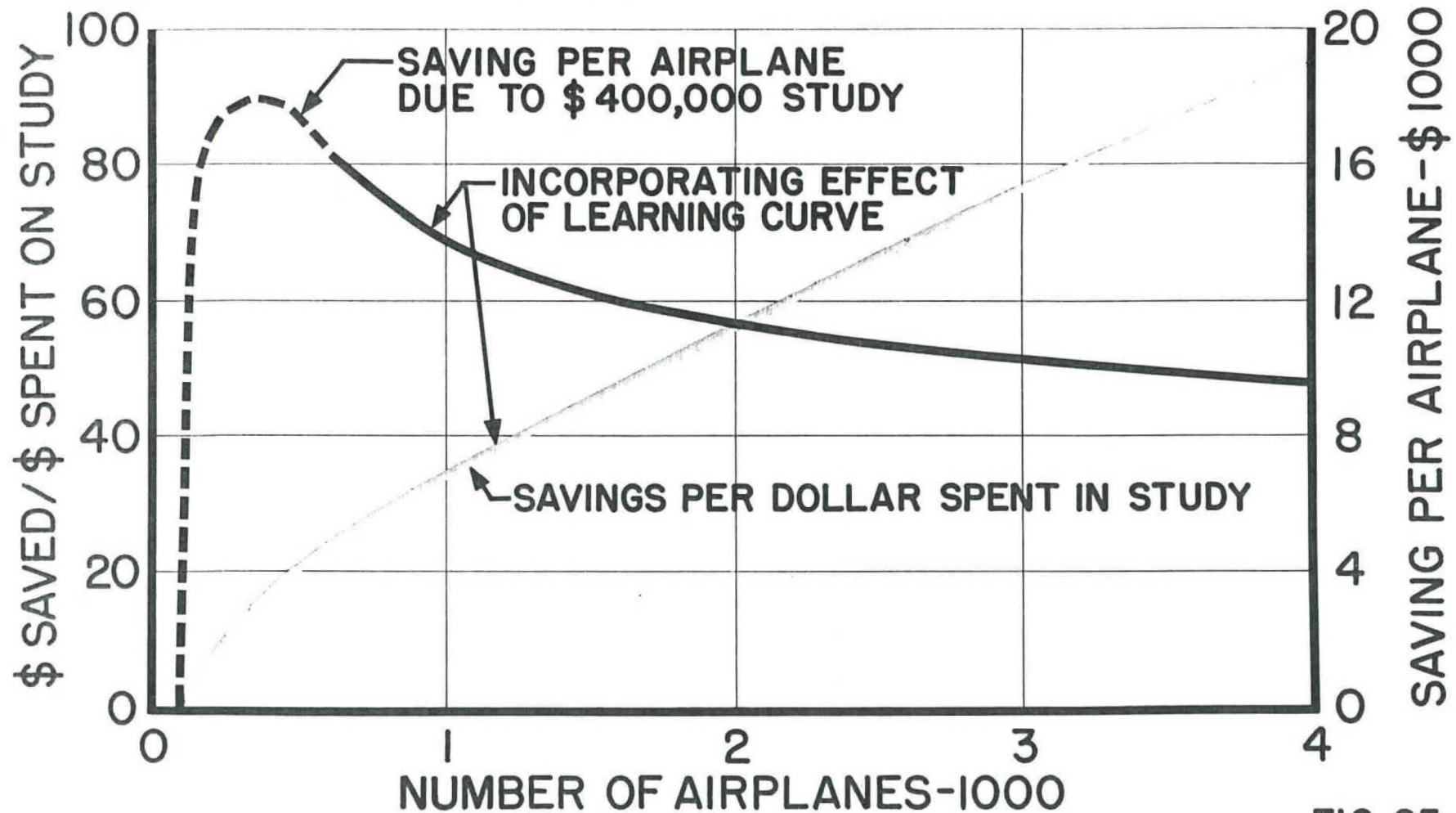

FIG. 25

~~CONFIDENTIAL~~
Lockheed AIRCRAFT CORPORATION

CALIFORNIA DIVISION

VI. VARIOUS PROBLEMS ENCOUNTERED

A. Pitchup

The problem of pitchup was first evaluated by Lockheed in October 1952 in attempting to put a low aspect ratio thin wing on the wind tunnel model of the XF-90. Pitchup is a term used to describe the maneuver that an airplane makes when it suddenly loses its normal longitudinal stability. It has occurred on a large number of different airplanes in various degrees. Its cause is a sudden blanketing of the horizontal tail surfaces by the wake from the wing, fuselage, or ducts and, in the case of the swept wing airplanes, from tip stall resulting in a forward movement of the aerodynamic center pressure. Low aspect ratio wings have very strong fields of downwash with large vortices which sometimes blanket the tail. Also, long fuselages required on supersonic airplanes, particularly those with ducts attached, develop strong vortices off the nose or ducts, which can combine with the wing tip vortices to give severe downwash conditions and low impact pressure conditions for the horizontal and vertical tail. Each configuration has its own particular problems with regard to pitchup. Horizontal tail position is a determining factor as to what angle of attack produces pitchup. Some configurations with short ducts close to the wing can escape pitchup, so that one cannot generalize from one

Lockheed AIRCRAFT CORPORATION

CALIFORNIA DIVISION

configuration to another. The wind tunnel predicts accurately conditions which will be encountered in pitchup (Figures 26, 27 and 28).

Figure 26 shows the subsonic pitchup problem. A normal slope of the longitudinal stability curve occurs up to about 16 degrees angle of attack. At that angle, for the Mach number in question, the tail becomes immersed in the rough flow from the fuselage and the wing stall. If the angle of attack is allowed to increase from this point, a severe nose-up pitch develops and is maintained through angles of attack above 40 degrees. Even with full nose-down stabilizer setting, it is possible to get a strong nose-up pitch, as shown on the same slide. In actual flight tests, the airplane at subsonic speeds gets about a 30-knot warning prior to pitchup. This warning is made up of buffeting, lateral instability, and then finally the airplane pitches nose upwards. It generally recovers by rolling over and diving. Because the vertical tail is also in the same poor flow pattern, direction stability is generally lost, so that the maneuver can assume different forms, involving high angles of yaw as well as high angles of pitch. With any reasonably slow approach to the stall, there is ample warning to the pilot to prevent his entering into this regime. The longitudinal control is so great, however, that it is possible to develop one unit of g acceleration in one-tenth second of time. If a pilot starts this maneuver at high altitude at high speed, he may not get sufficient warning from

HIGH ANGLE OF ATTACK PITCHUP

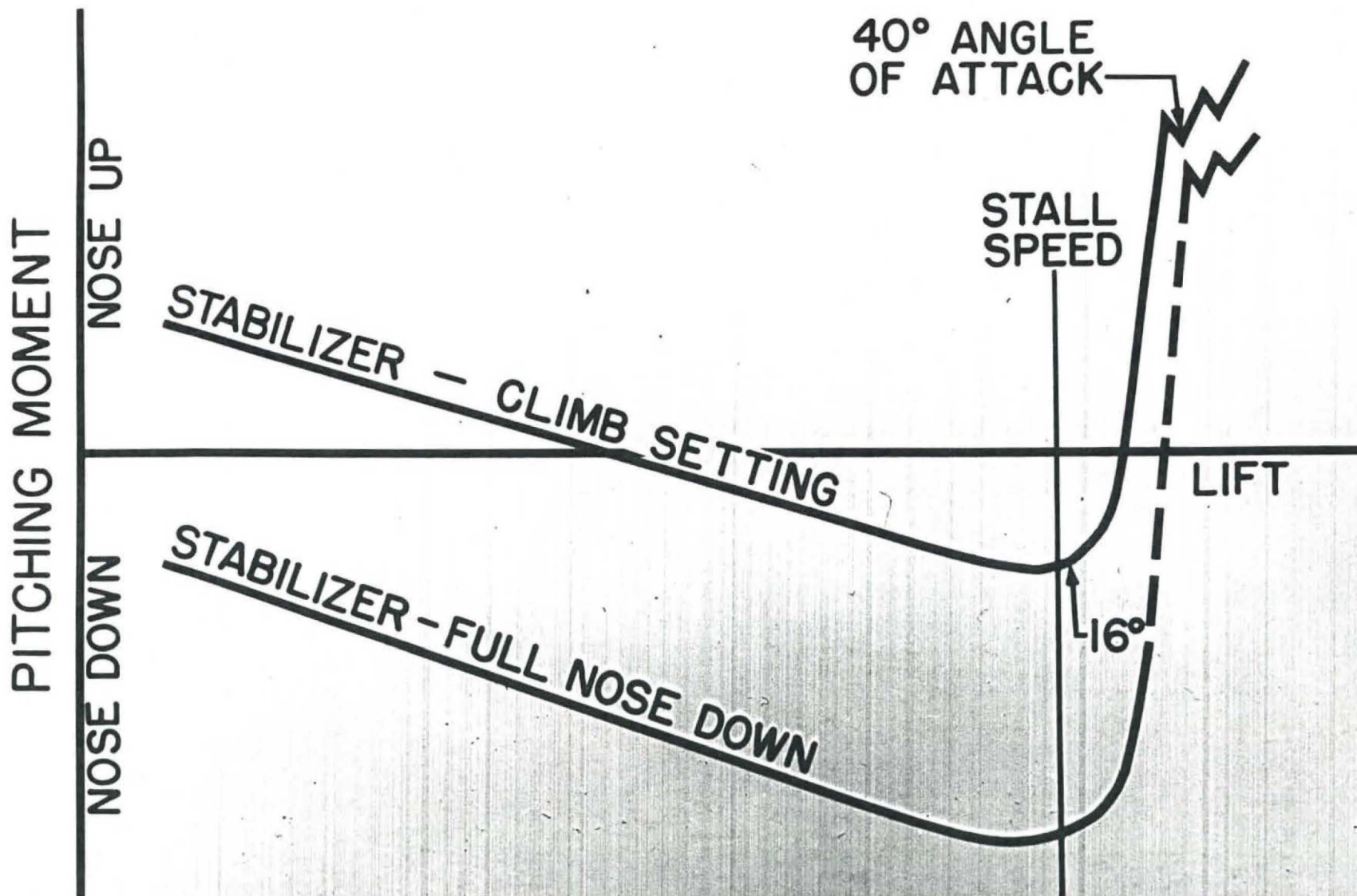

FIG. 26

FLOW PATTERN FOR PITCHUP

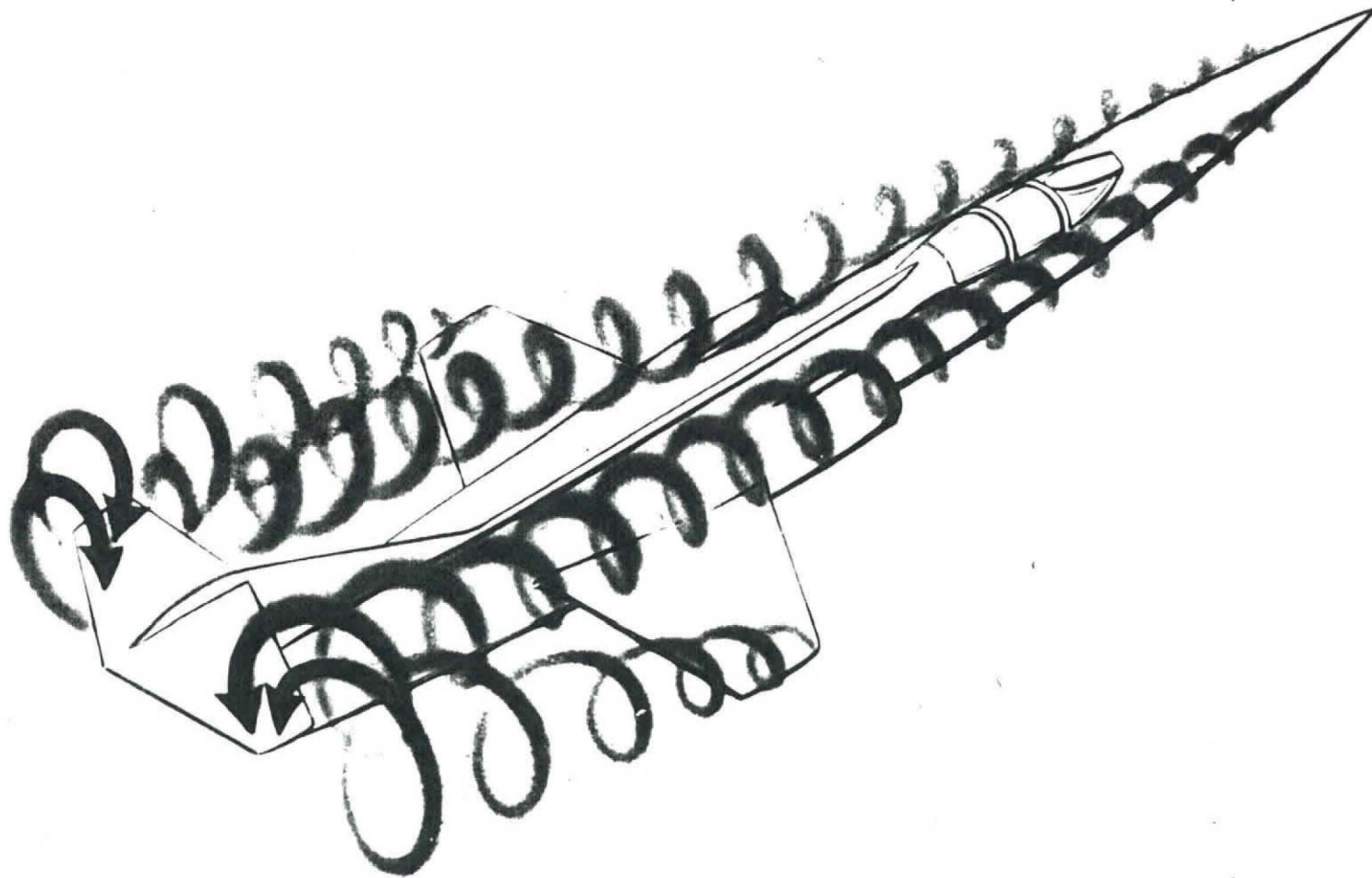

FIG. 27

CONFIDENTIAL

VARIOUS FORMS OF PITCHUP

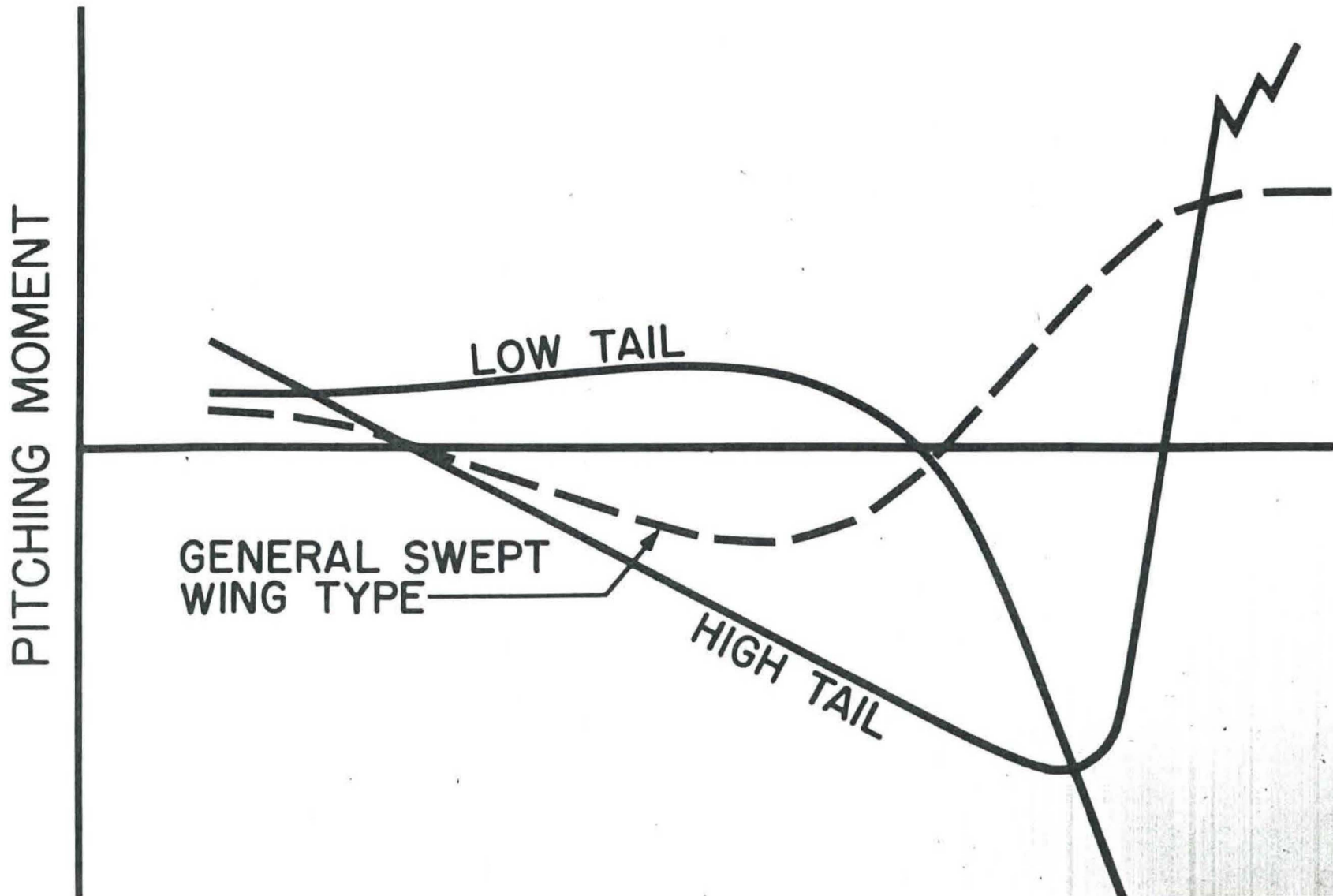

FIG. 28

~~CONFIDENTIAL~~
Lockheed AIRCRAFT CORPORATION

CALIFORNIA DIVISION

aerodynamic sources and will essentially do a horizontal snap roll.

When first encountered by Lockheed, a series of tests was undertaken immediately to determine what configuration changes would eliminate pitchup. Prior to the first flight of the XF-104, some ninety-eight configuration modifications had been tested to find an aerodynamic solution for pitchup. Figures 29 through 37A show some of the various ideas tried. It was possible in many cases to eliminate pitchup, but always at a cost in other characteristics felt to be totally unacceptable. The use of a low tail in almost every case eliminated pitchup on the F-104, but, when it did, the normal longitudinal stability, the directional stability, drag, weight, and over-all combat utility of the airplane were seriously compromised. Attempts were made, unsuccessfully, to use boundary layer control on the wing, fuselage, and canopy to control pitchup.

Having tried and discarded all forms of aerodynamic modifications which we could think of, and apparently which anyone else has since thought of, it was decided to take the good features of the high tail position and provide artificial warning and stability to prevent pitchup maneuvers.

In October 1953, an automatic pitch control was developed in theory, which showed that two things must be done to provide safety from

F-104 MODEL WITH DESIGN HORIZONTAL ON BOTTOM OF FUSELAGE

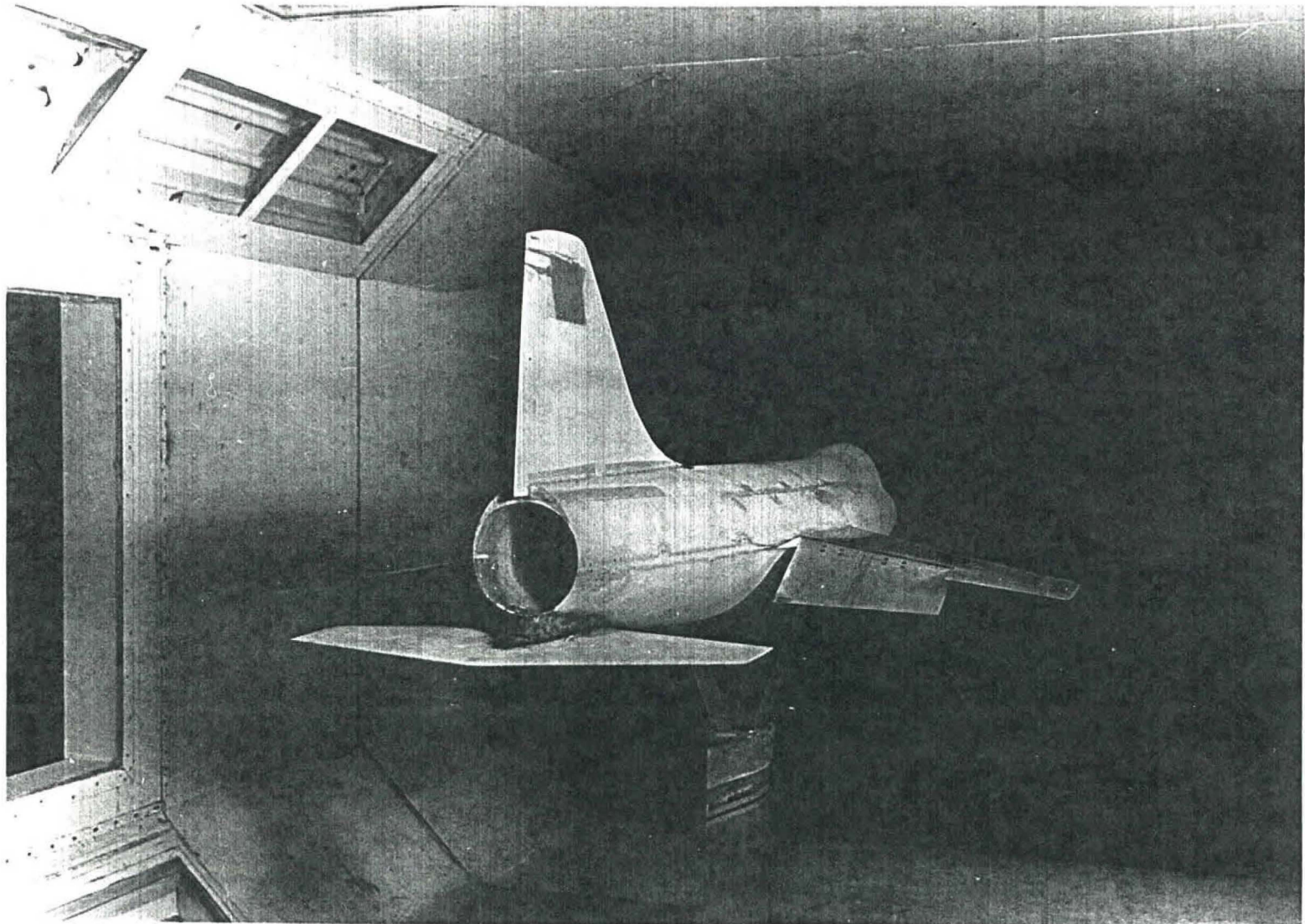

FIG. 29

F-104 MODEL WITH DESIGN HORIZONTAL
AT INTERSECT. OF VERT. TAIL AND FUS.

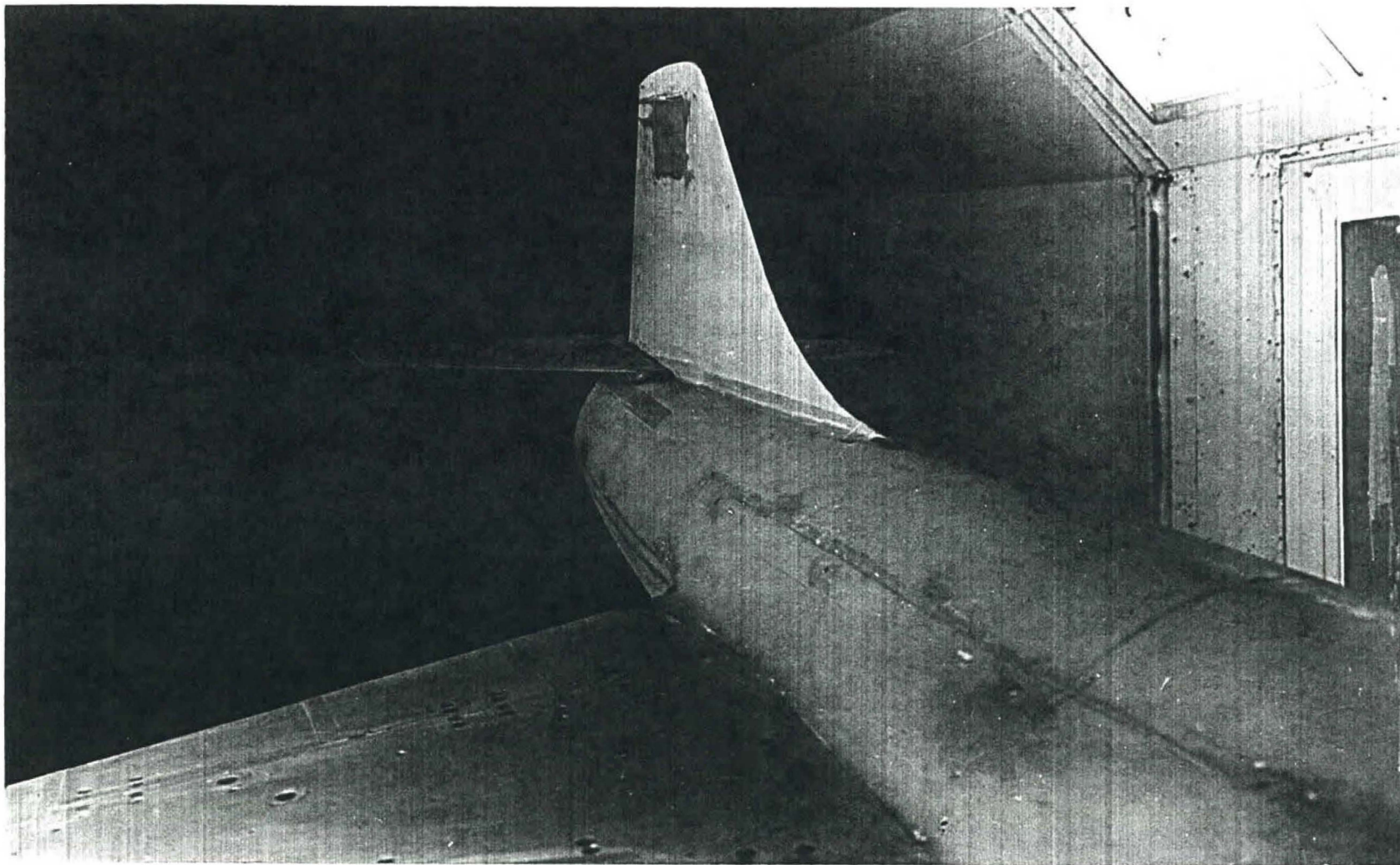

FIG. 30

~~CONFIDENTIAL~~

~~CONFIDENTIAL~~

F-104 MODEL WITH FWD. TRIMMER VANES

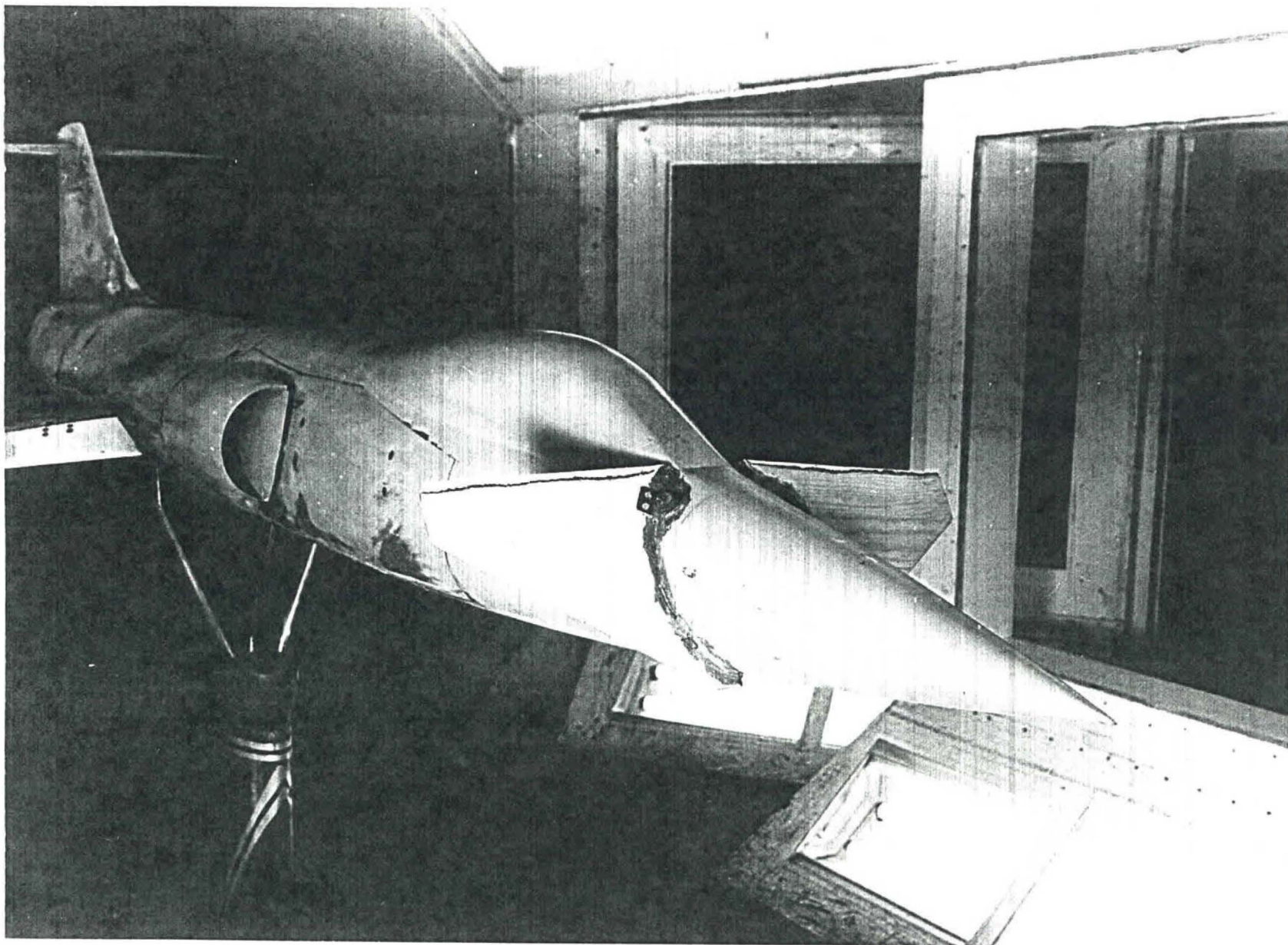

FIG. 31

F-104 MODEL WITH DESIGN HORIZ. SPAN
INCR. 3 IN. AND RECT. TRIMMER ON
BOTTOM OF AFT FUSELAGE

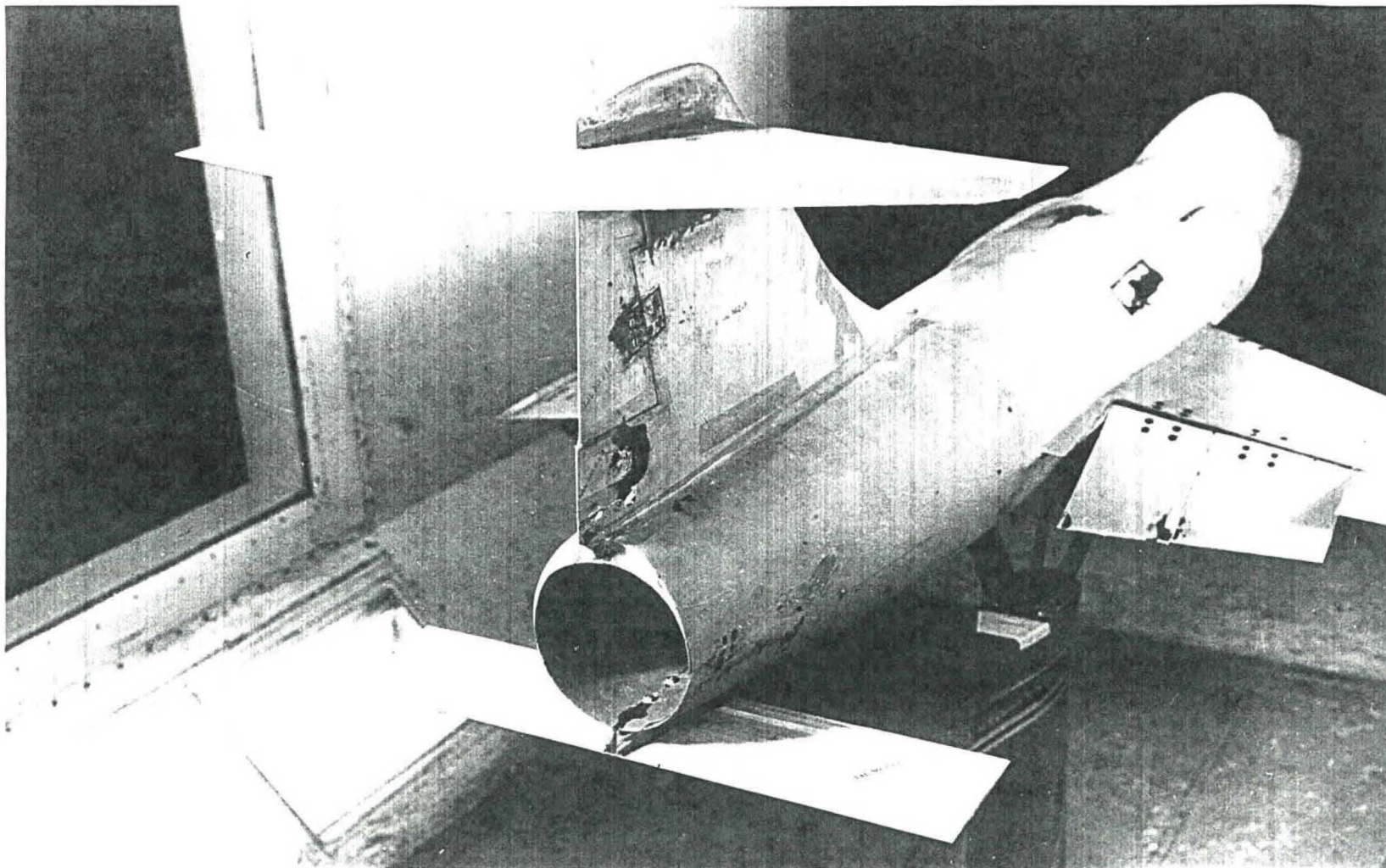

FIG. 32

F-104 MODEL WITH STRAIGHT T.E.
HORIZONTAL TAIL ON F.R.L.

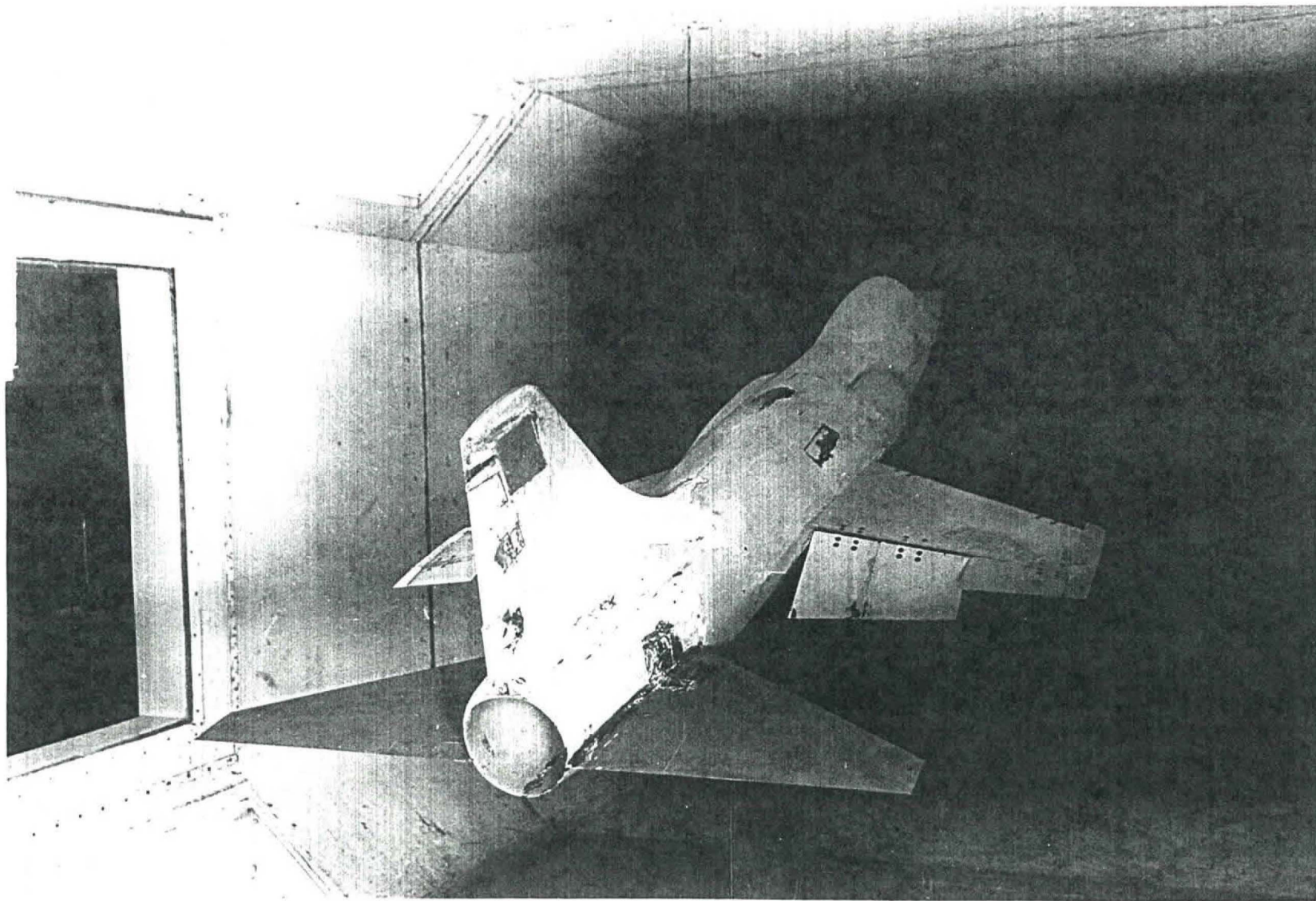

FIG. 33

F-104 MODEL WITH VEE TAIL

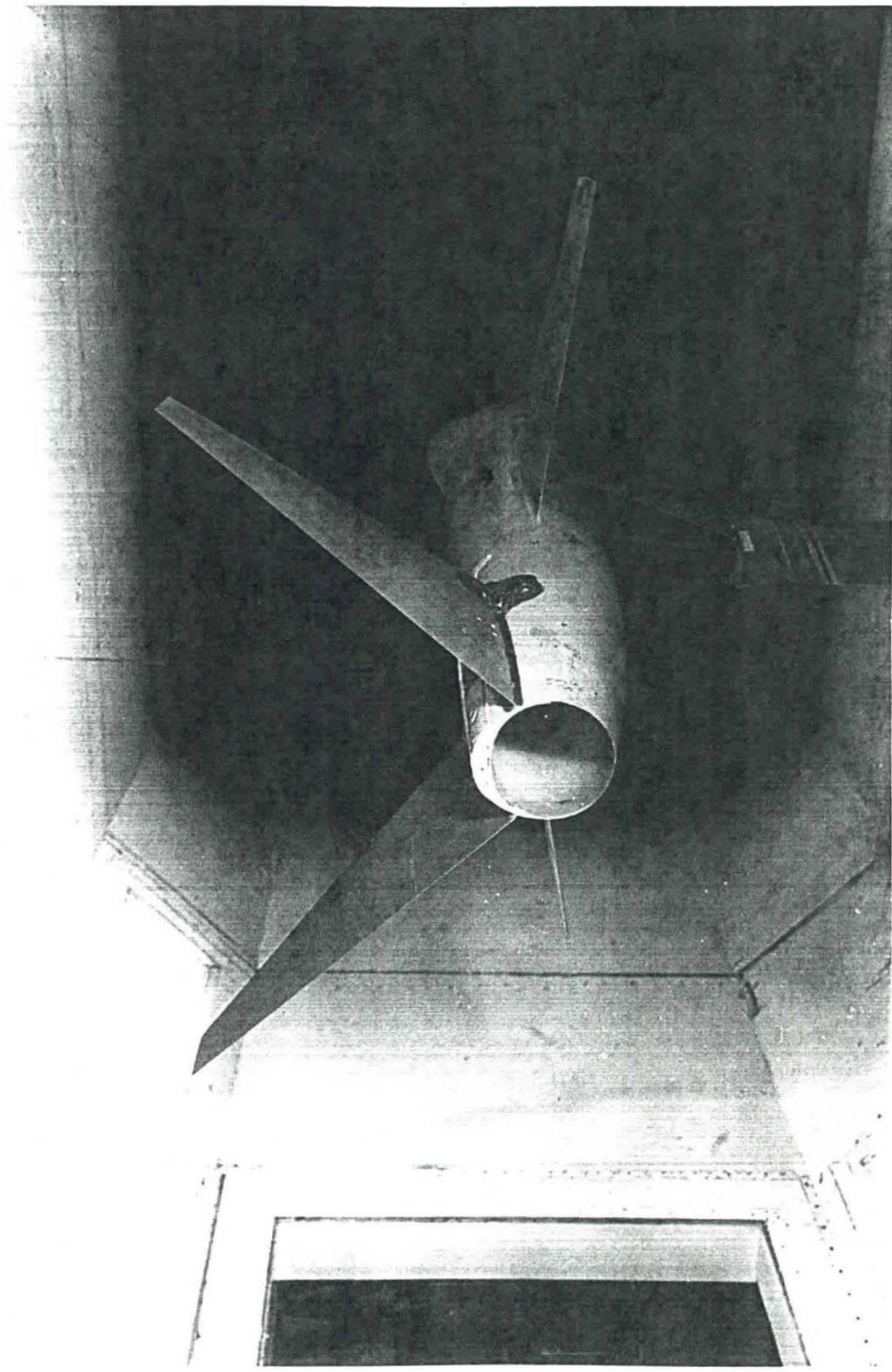

FIG. 34

F-104 MODEL WITH HORIZ. FINS AT F.R.L.

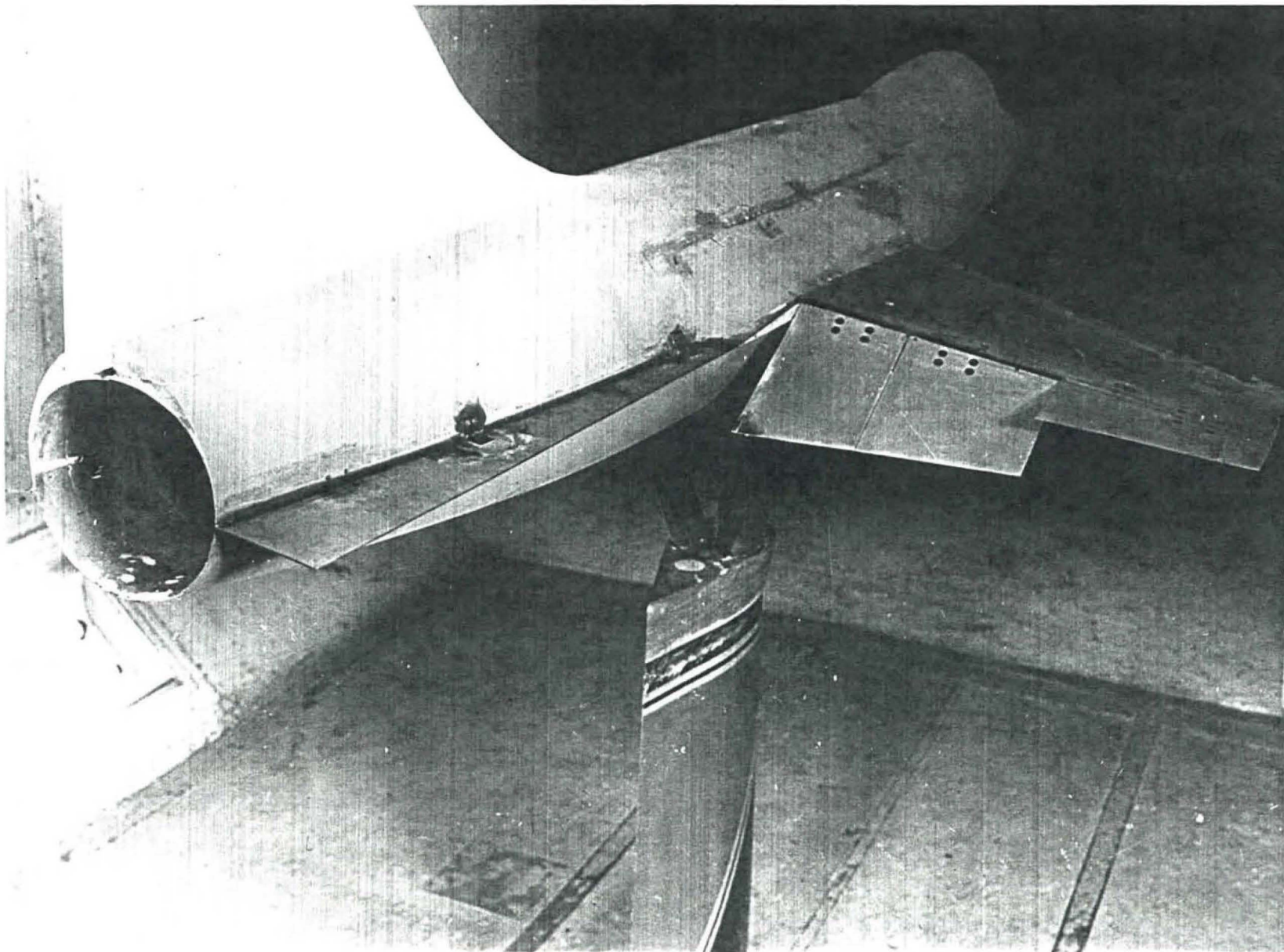

FIG. 35

F-104 MODEL WITH BOUNDARY LAYER
CONTROL AREAS ON FUSELAGE

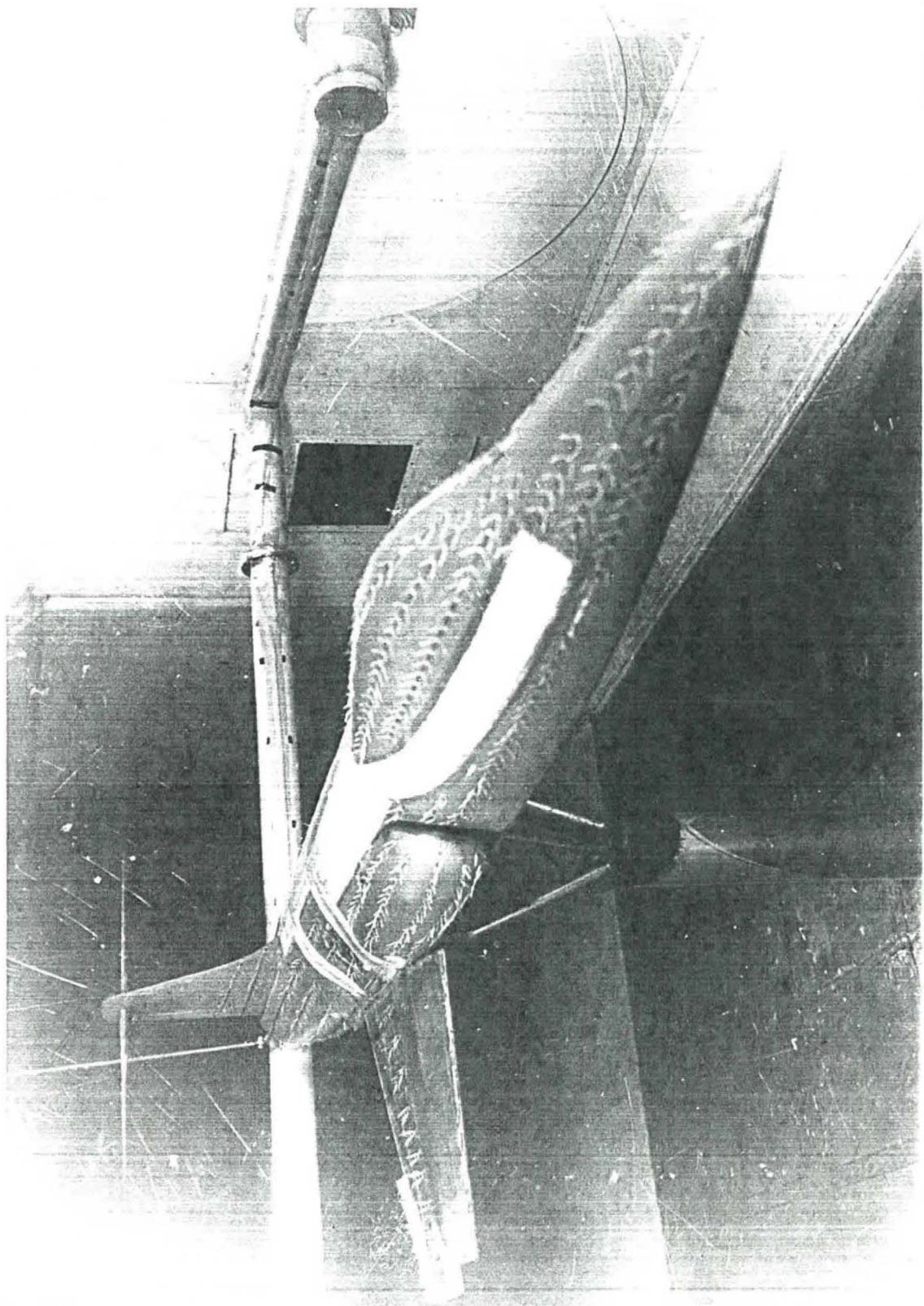

FIG. 36

EMPENNAGE CONFIGURATION

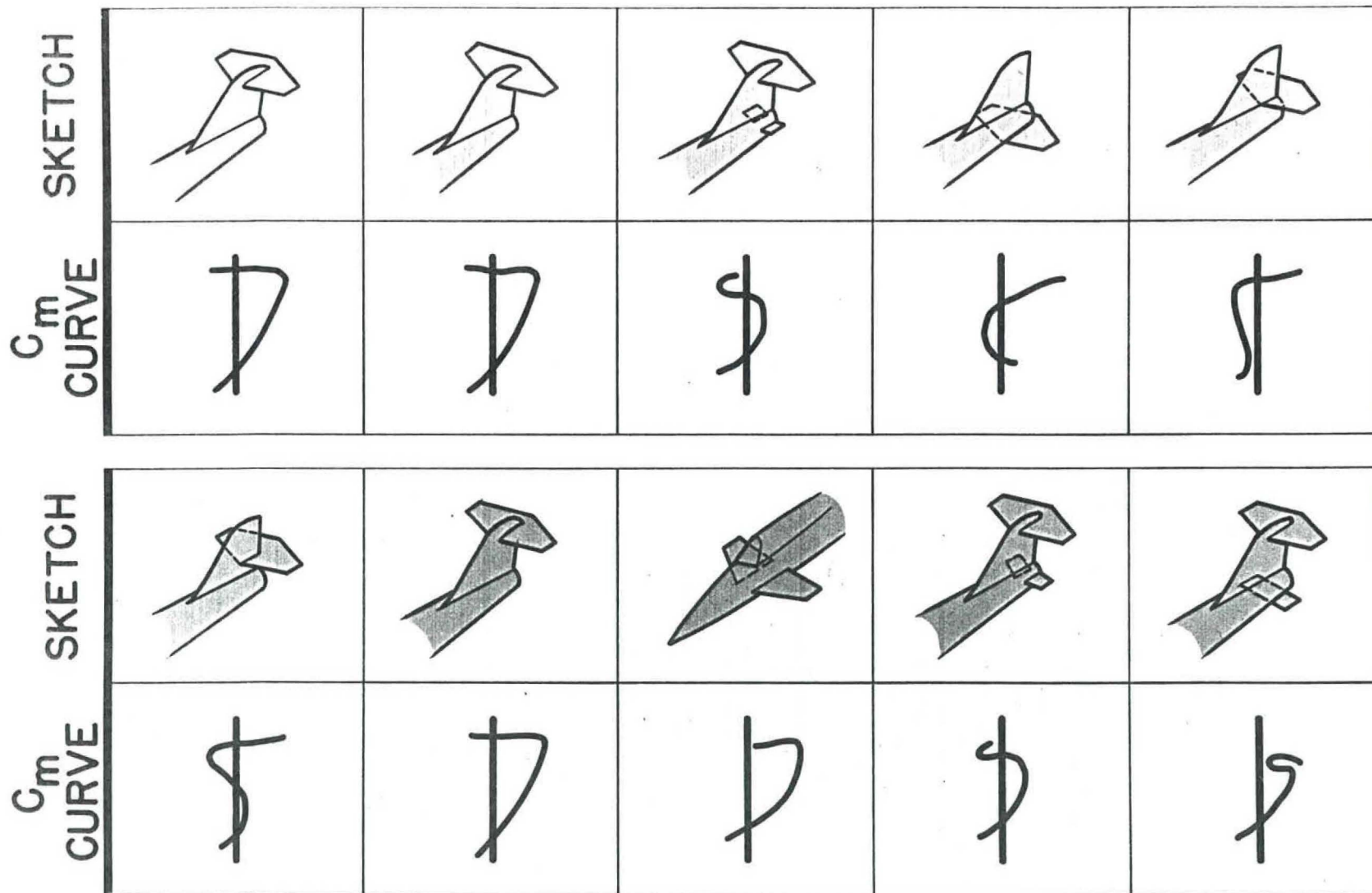

FIG. 37

EMPENNAGE CONFIGURATION

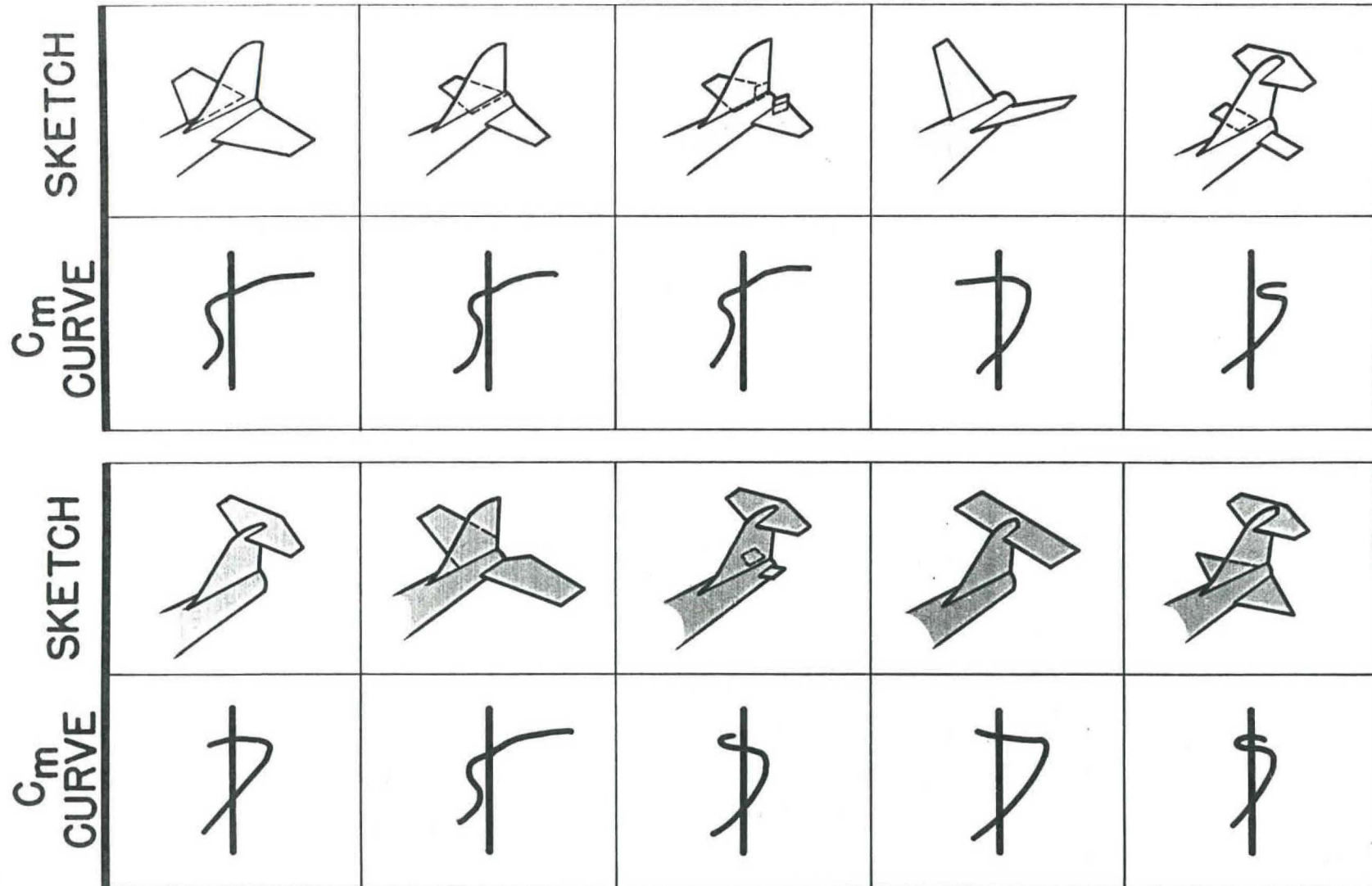

FIG.37A

~~CONFIDENTIAL~~
Lockheed AIRCRAFT CORPORATION

CALIFORNIA DIVISION

pitchup. There must be an input signal from angle of attack to cover the cases of slow approach to the pitchup angle, but there must also be a factor put into the control which would be a function of the rate of pitch.

The final form of the developed automatic pitch control (APC) is shown in a schematic drawing (Figure 38). The rate of pitch is fed into the longitudinal control by a gyro system to increase the apparent stability. The amount of the stick force (which is adjustable) is about 35 pounds pull force. The rate of pitch factor is also combined to feed into the angle of attack warning system and stick shaker. There is a dual vane arrangement on the nose which provides such angle of attack warning. It was necessary to include what is known as a "washout circuit" for periods of prolonged turn where various force components due to the turn would be fed into the warning system and give improper warning.

Figure 39 shows the operation of the automatic pitch control for various sharp maneuvers. It is believed that this device is an excellent solution to the pitchup problem for the specific configuration of the F-104 and probably other types.

Figure 40 shows the effect of Mach number on the changes in the buffet, lateral instability, and neutral longitudinal stability limits. In the supersonic region, angles of attack above 20° to 25° must be

AUTOMATIC PITCH CONTROL INSTALLATION

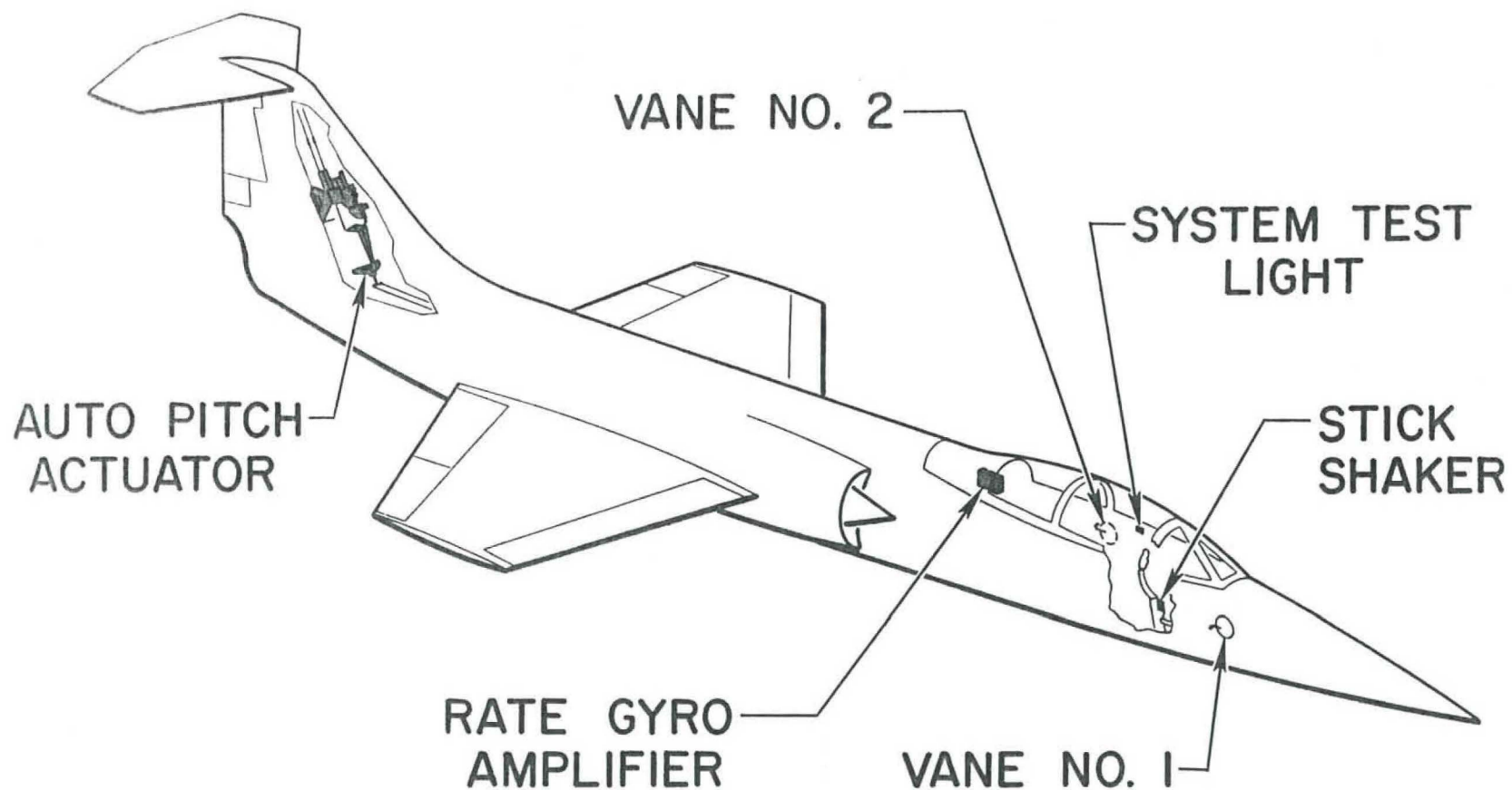

FIG. 38

TYPICAL MANEUVERS WITH AUTOMATIC PITCH CONTROL

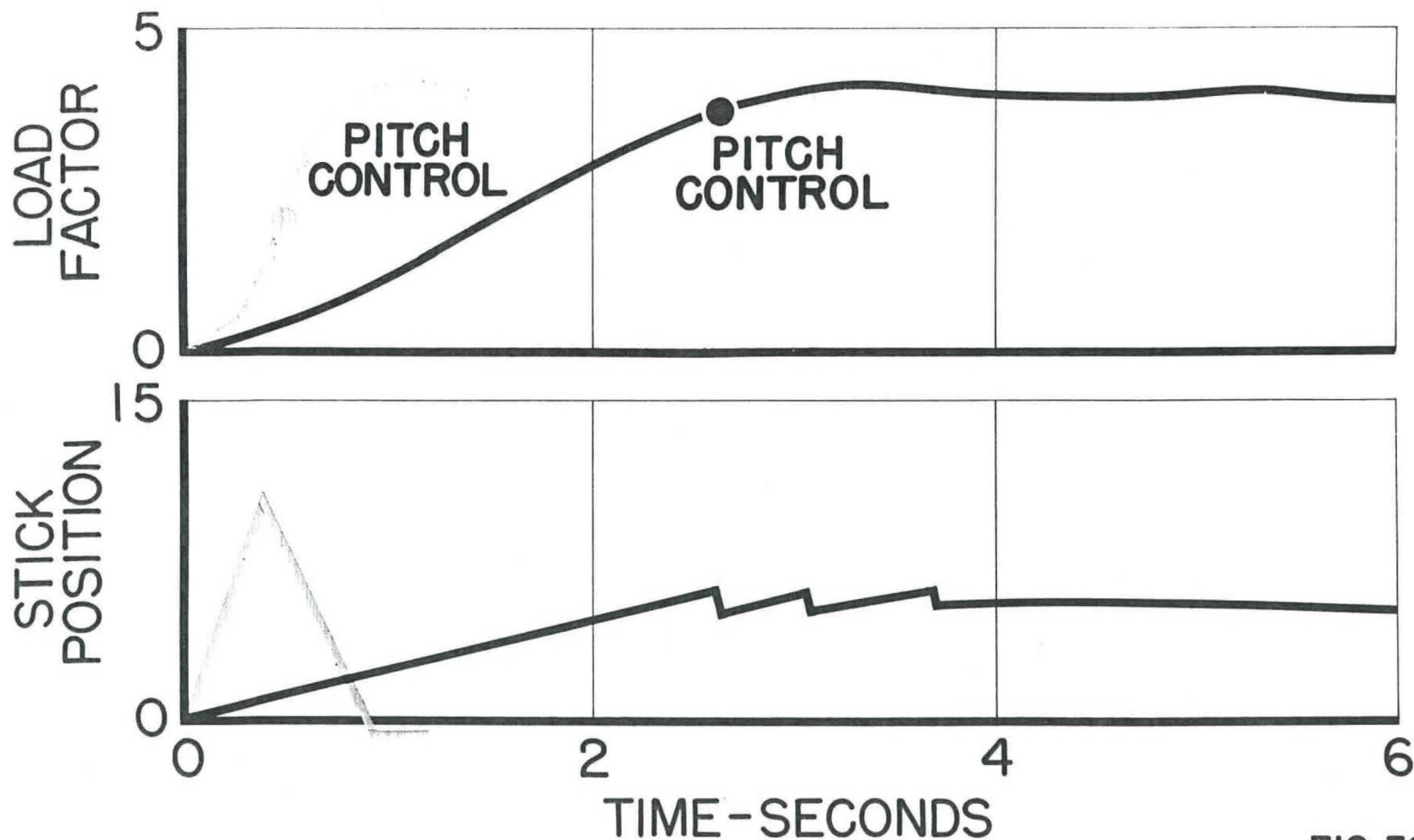

FIG. 39

F-104A STALL CHARACTERISTICS vs MACH NUMBER

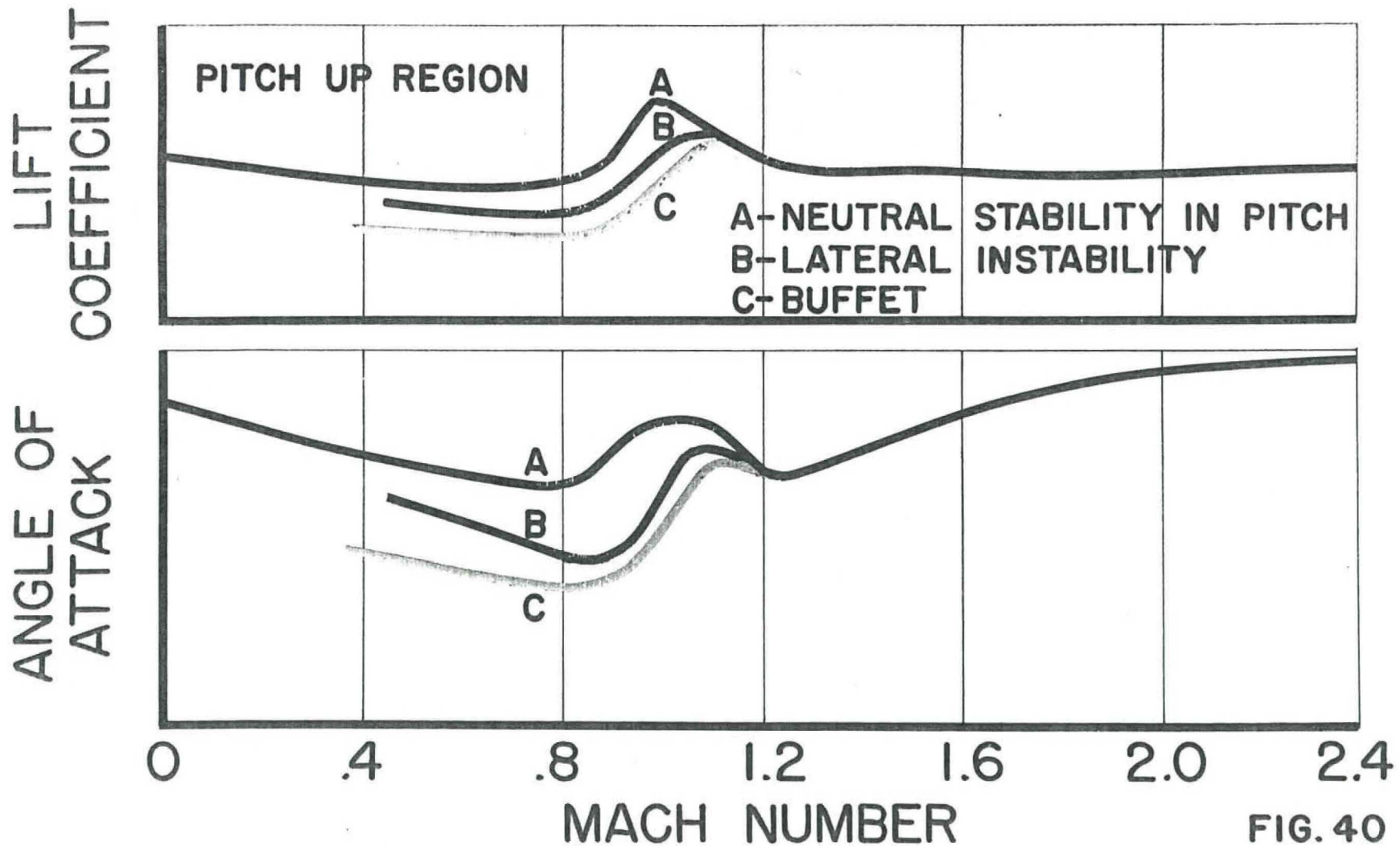

FIG. 40

~~CONFIDENTIAL~~
Lockheed AIRCRAFT CORPORATION

CALIFORNIA DIVISION

encountered prior to pitchup. In this region the complete flow picture is, of course, different from that existing subsonically.

B. Roll Coupling

The subject of roll coupling on the F-104 has been dealt with at considerable length by Heppe and Celsiker in their report. (2) The F-104 configuration is such that very good basic stability exists even through the transonic region, and roll coupling has not been an important problem on the airplane to this point. By placing the horizontal tail above the vertical tail, the latter has a very high effectiveness, particularly since it is provided with an end plate on the lower end by the fuselage.

The variation of directional stability with Mach number is shown in Figure 41. The mere provision, however, of good directional and lateral stability does not insure that a configuration will be totally free from problems of inertia coupling. The critical condition for encountering this problem on the F-104 is at low or negative lifts. It appears that rates of roll of well over 180° per second will have to be encountered at Mach numbers between 1.4 and 1.6 before any inertia coupling will be encountered. During the flight test program on the experimental airplane, some 350 rolls, carrying through three total revolutions in most cases, and at altitudes ranging from 10,000 to 40,000 feet, were made. Our aerodynamics group

(2) Airplane Design Implications of the Inertia Coupling Problem, by R. Richard Heppe and Leo Celsiker, Lockheed Aircraft Corp., presented at the I. A. S. National meeting in New York, January 1957.

TYPICAL DIRECTIONAL STABILITY VARIATION WITH MACH NUMBER

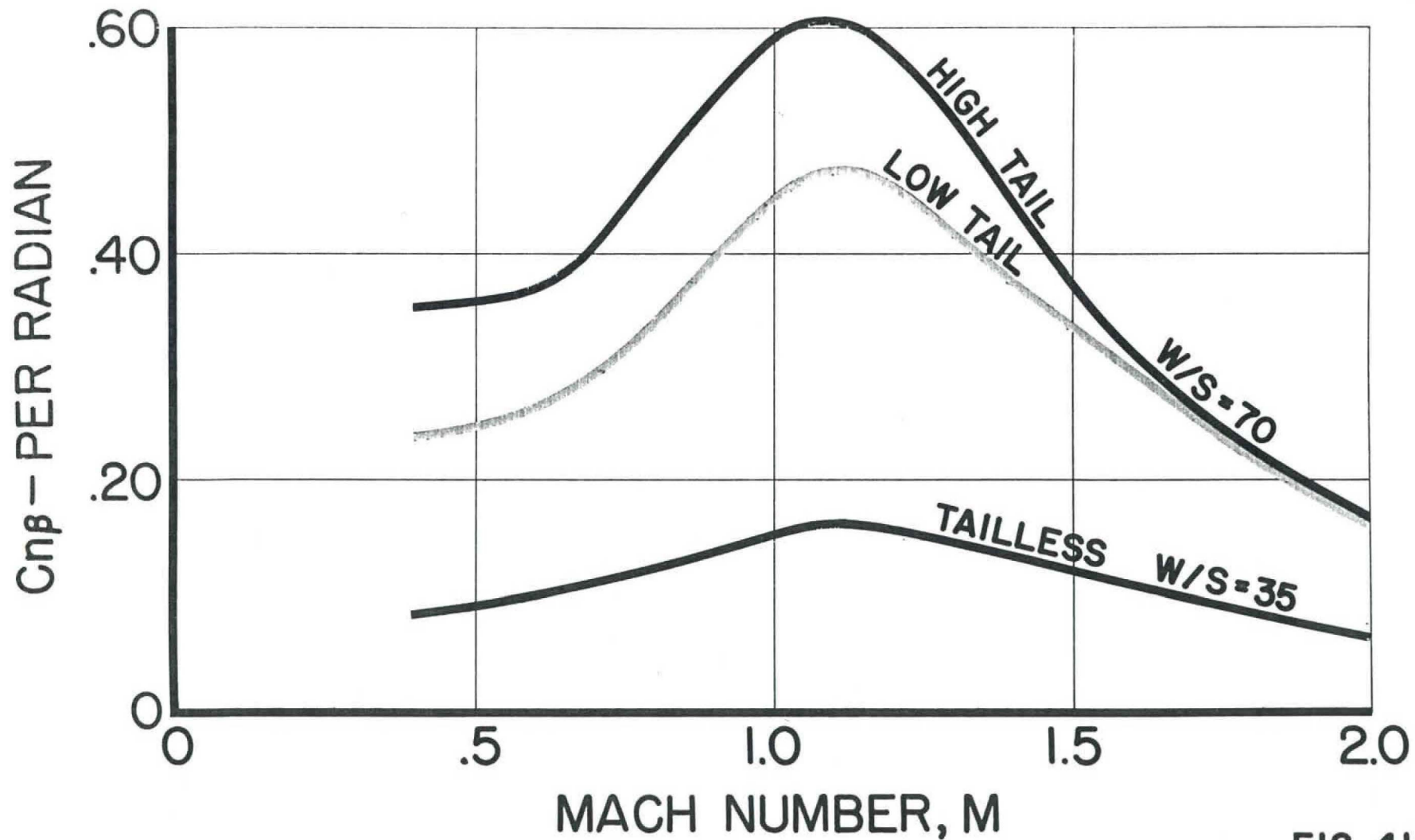

FIG. 41

Lockheed AIRCRAFT CORPORATION

CALIFORNIA DIVISION

has been able to set up theoretical computation means which show excellent agreement between flight tests on the various factors affecting inertia coupling. This subject has been so well covered in the paper referred to above that it will not be dwelt on in this report, except to say that the basic configuration seems to be less sensitive to the inertia coupling problem than a number of other supersonic types investigated. This is one of the benefits obtained from choosing to face the pitchup problem previously described (Figure 42).

C. Powerplant Problems

The experimental XF-104 was powered with a Wright J65 engine and afterburner, capable of developing about 10,500 pounds of sea level static thrust. This was not sufficient thrust to require the use of a very involved air inlet ducting system. When the General Electric J79 engine was provided for the production airplane, speeds could be reached which required a more complicated form of ducting than on the experimental airplane. A great deal of wind tunnel testing was done in our own and NACA wind tunnels to develop a sophisticated type of inlet and bypass system for the F-104A. The duct finally developed makes use of a fixed cone in front of the duct and a variable bypass arrangement to allow a certain percentage of the air that hits the duct to flow between the engine and the fuselage skin and finally out an augmentor arrangement around the afterburner. Not

COMPARISON BETWEEN COMPUTATION & FLIGHT MEASUREMENT LEFT ROLL FROM 0g PUSHOVER

— FLIGHT MEASUREMENT
— COMPUTATION

M=.97 h=39,270

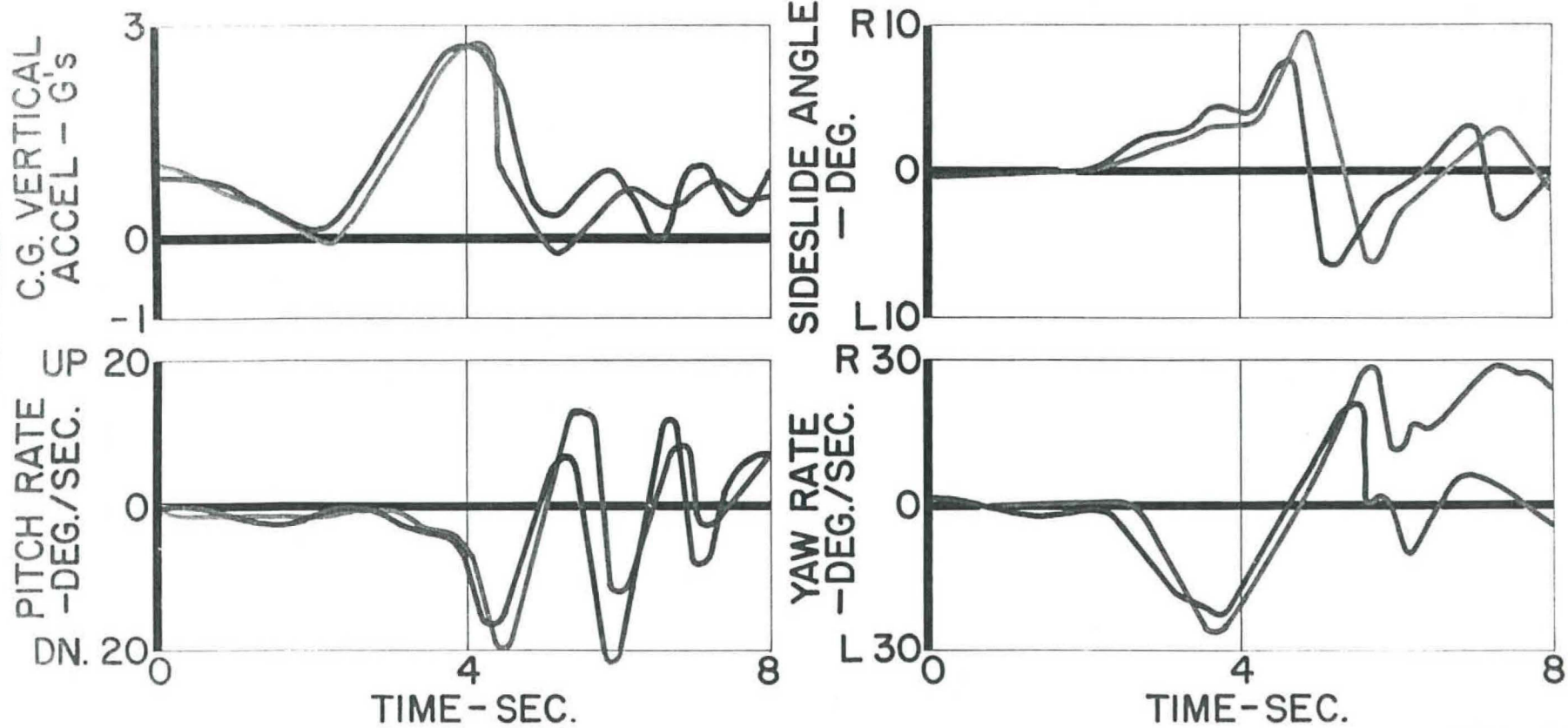

FIG. 42

Lockheed AIRCRAFT CORPORATION

CALIFORNIA DIVISION

only is excellent ram obtained for the engine by this arrangement, but an aerodynamic nozzle is formed, so that the proper expansion can take place behind the afterburner to obtain a good thrust coefficient over-all. Figure 43 shows a schematic diagram of the ducting arrangement. This form of inlet arrangement provides obviously excellent cooling (within the limits of the adiabatic rise) and good fire protection against fuel leaks and battle damage.

The use of the variable bypass may not be necessary in certain cases, but the writer is of the opinion that it is worthwhile and will provide a certain measure of safety for several conditions which have not yet been encountered at high Mach number. Should the engine blow out at extreme speeds, there is every likelihood that the duct would immediately stall and the resulting flow pattern cause severe blanketing not only of sections of the wing but of the vertical and horizontal tail. This problem will be common to all high speed supersonic airplanes and requires a great deal more consideration and study than have been given to it up to this time.

Ability to obtain high ram at high Mach number is extremely important to the supersonic airplane (Figure 44). It makes possible the use of a supersonic ceiling that is above the subsonic ceiling of the airplane. Good ram improves engine distribution - practically always reduces drag.

When we combat at high Mach number and high altitude,

EJECTOR AIR

EXHAUST GASES

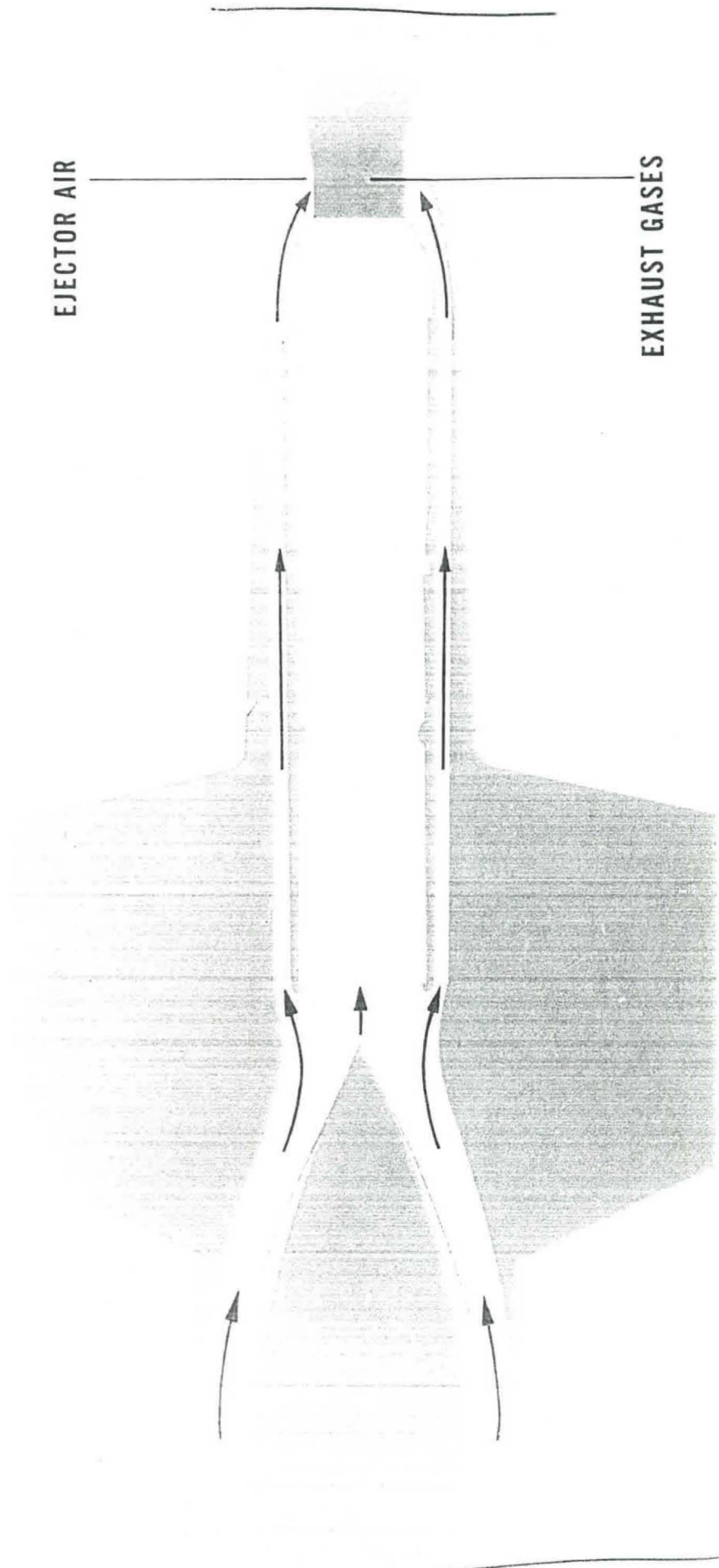

ENGINE BYPASS SYSTEM

FIG. 43

INLET TOTAL PRESSURE RECOVERY

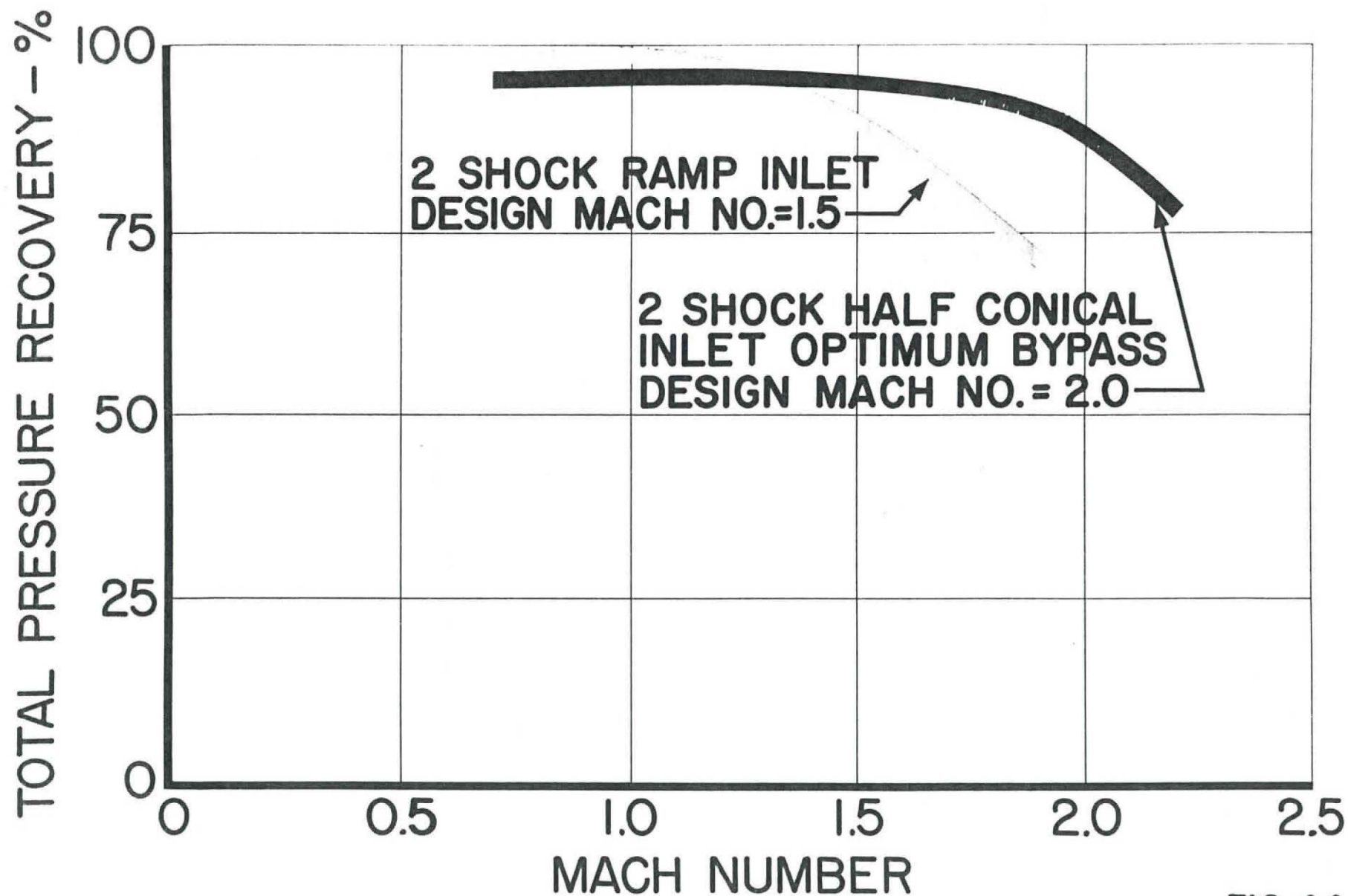

FIG.44

Lockheed AIRCRAFT CORPORATION

CALIFORNIA DIVISION

unfortunately our present configurations of high speed aircraft, utilizing low aspect ratios and high wing loadings, tend to make the duct problem very difficult. Variations of angle of attack in maneuvers can change the air distribution to the engine and cause high altitude engine blowouts. To insure safety to the pilot under these conditions, a partial pressure suit must be used. This has proven to be a very reliable device, but extremely uncomfortable, particularly when long periods of pre-oxygenation are required prior to flight. Figure 45 shows such a suit.

A new problem was encountered on the F-104 in regard to previous practices of afterburner modulation. Figure 46 shows basic airplane drag and thrust curves. In the non-afterburning condition, a normal speed of about Mach 1 is obtained. If the full afterburning output would be used over a considerable range of altitudes, there would be no intersection of the drag and thrust curves within the arbitrary engine temperature limits. Should it be desired to stabilize flight at a Mach number of, say, 1.5, it would be necessary to modulate the amount of afterburning. In certain regions it would also be very difficult to fly formations (or make good attacks on a bomber), in that close thrust control is required for equal speeds on two or more aircraft. The problem of getting a field of power between the full amount of afterburning and non-afterburning requires substantial development work, and the initial attempts to obtain this modulation efficiency are



FIG. 45

TYPICAL THRUST & DRAG AT 35,000 FT.

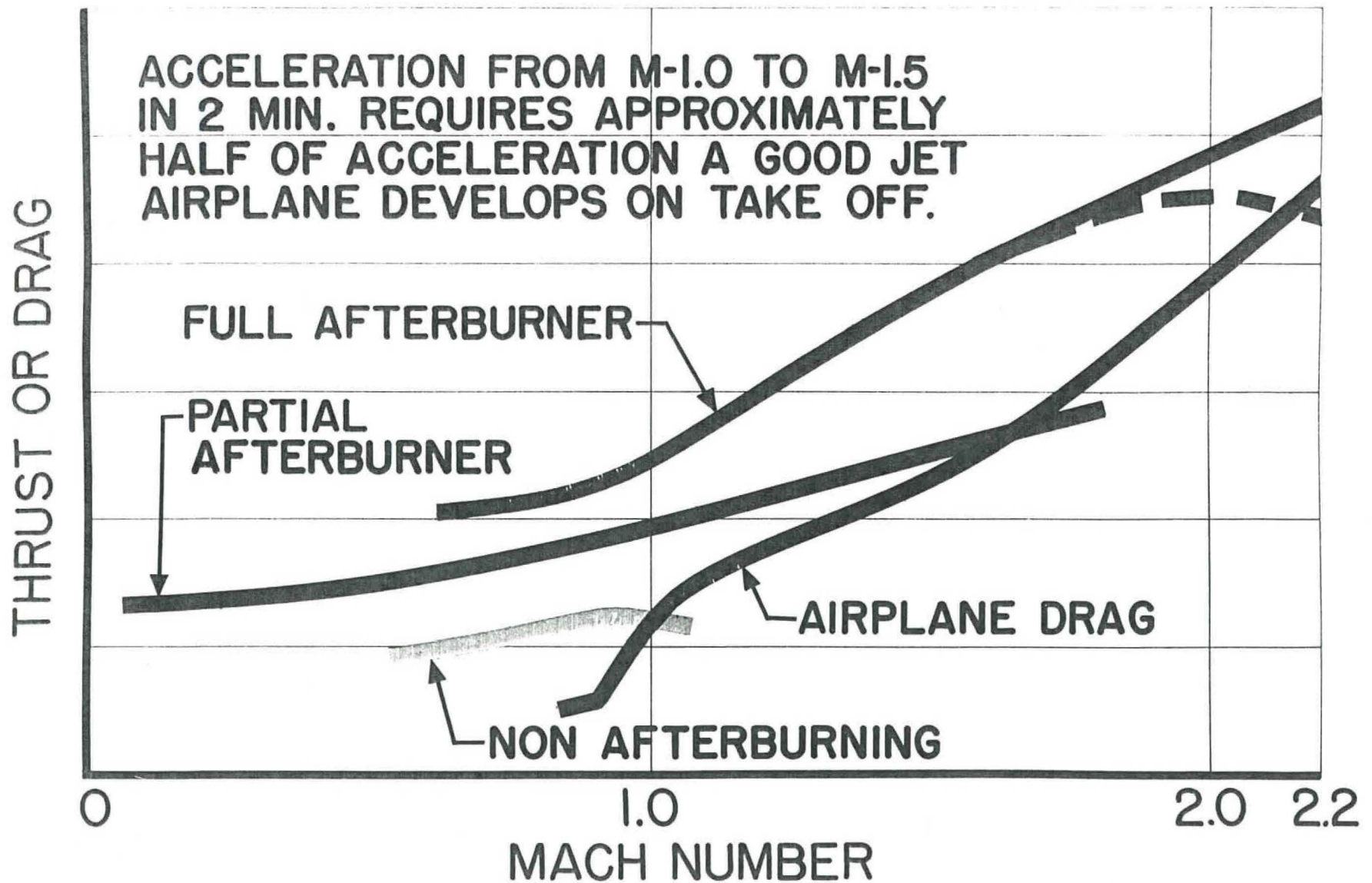

FIG. 46

Lockheed AIRCRAFT CORPORATION

CALIFORNIA DIVISION

not fully successful. This does not seem to be a problem that is incapable of solution with a moderate degree of development.

D. High Speed Escape

In the early design studies of the XF-104, every effort was made to attain the simplest and safest ejection seat arrangement that was known at the time. Downward ejection was chosen for a number of reasons. There was a much more reliable tie-in between the seat and the lower escape hatch than can generally be obtained with canopies which require ejection. Downward ejection also insured raising the horizontal and vertical tail, each having a leading edge radius of .61" inches. This ejection system also allowed for a better positioning of the instrument board and involved lower escape g's.

As experience was gathered on other high speed airplanes, it became apparent that a standard ejection seat would not be able to cope with the high indicated speeds of the subject airplane. A group was organized under Mr. Irwin Culver to investigate the possibility of reducing the air load on the pilot and preventing tumbling of the seat, so that the speed envelope for safe escape could be improved in keeping with the airplane performance. Figure 47 indicates the type of performance sought with our advanced seat. By making use of a skip flow generator, small retractable vanes alongside the seat to provide roll damping, and vertical vanes for yaw stability, a

SAFE ESCAPE LIMITS OF "D" SEAT EXCEED 800 KNOTS AT SEA LEVEL AND MACH 3.0 AT ALTITUDE

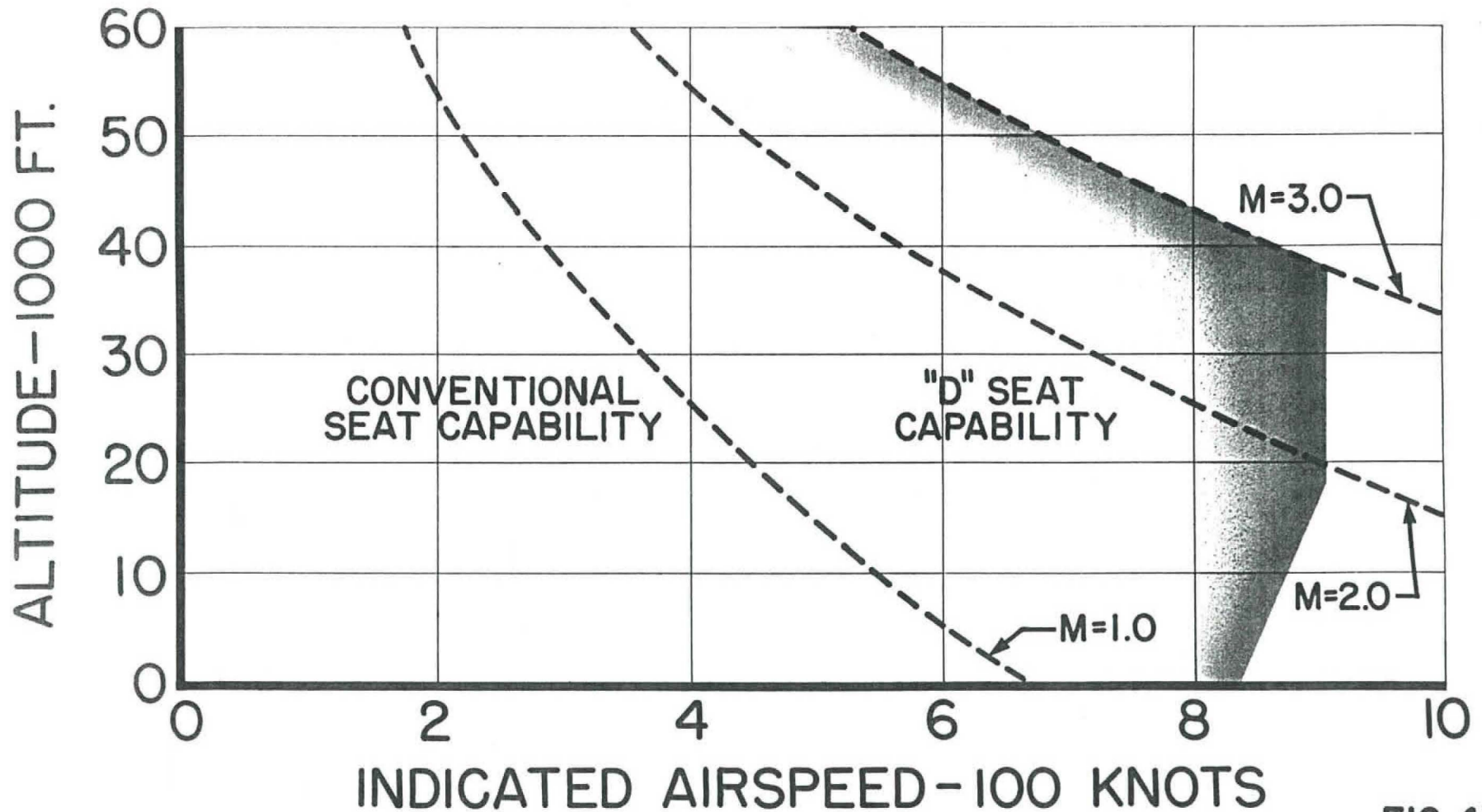

FIG. 47

~~CONFIDENTIAL~~
Lockheed AIRCRAFT CORPORATION

CALIFORNIA DIVISION

substantial improvement in ejection seat capability has been obtained, as shown on films taken at Hurricane Mesa. Wind tunnel tests showed the application of the skip-flow generator to be very important in reducing the drag of the occupied seat and the airload on the pilot. Figures 48 and 49 show Schlieren pictures taken in model tests. There is every indication that the design objectives for the seat have been attained, but actual live jumps have not been made at high speed to this time.

There is a continual inquiry about the use of capsules for high speed escape. It is the writer's opinion that the sacrifices which must be made to adapt a capsule to our high speed aircraft are not warranted and that the capsule does not necessarily provide a higher degree of safety than can be obtained with ejection seats as a result of further studies and improvements in personnel equipment. The problems of making disconnects from many controls (radio, etc.), as well as the problems of stabilizing the capsule itself, present many difficulties and sacrifice performance, simplicity, and maintainability in any designs which the writer has seen to date. There is likewise the problem, becoming more and more important, of escape on takeoff, landing, and low altitude flight. Unless a very large parachute is carried, which can lower the capsule plus the occupant, there will be a double escape problem of getting the capsule out of the airbase and then the man out of the capsule. Downward ejection, of course, does not

STANDARD SEAT AT MACH 2.0

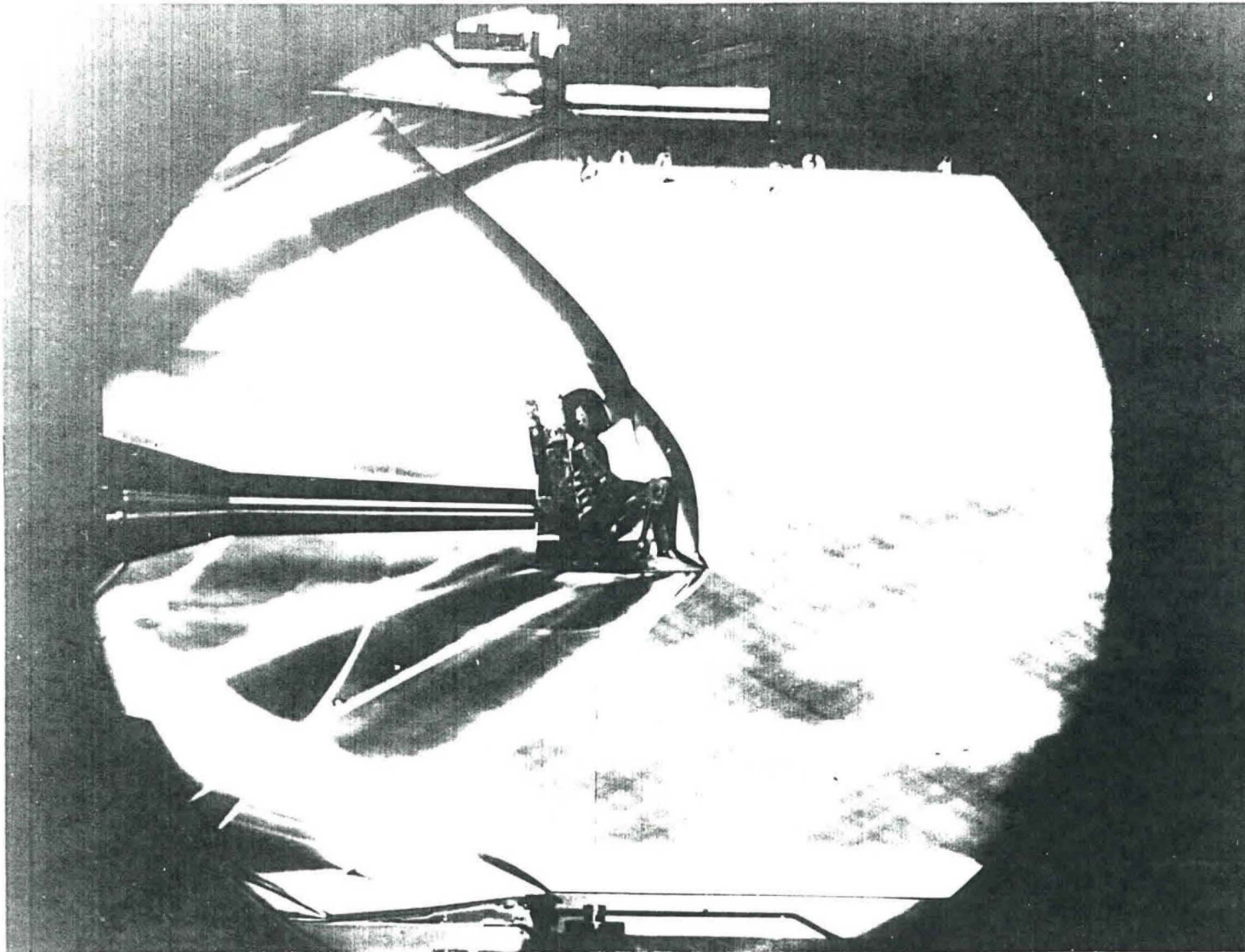

FIG. 48

MODEL "D" SEAT AT MACH 2.0

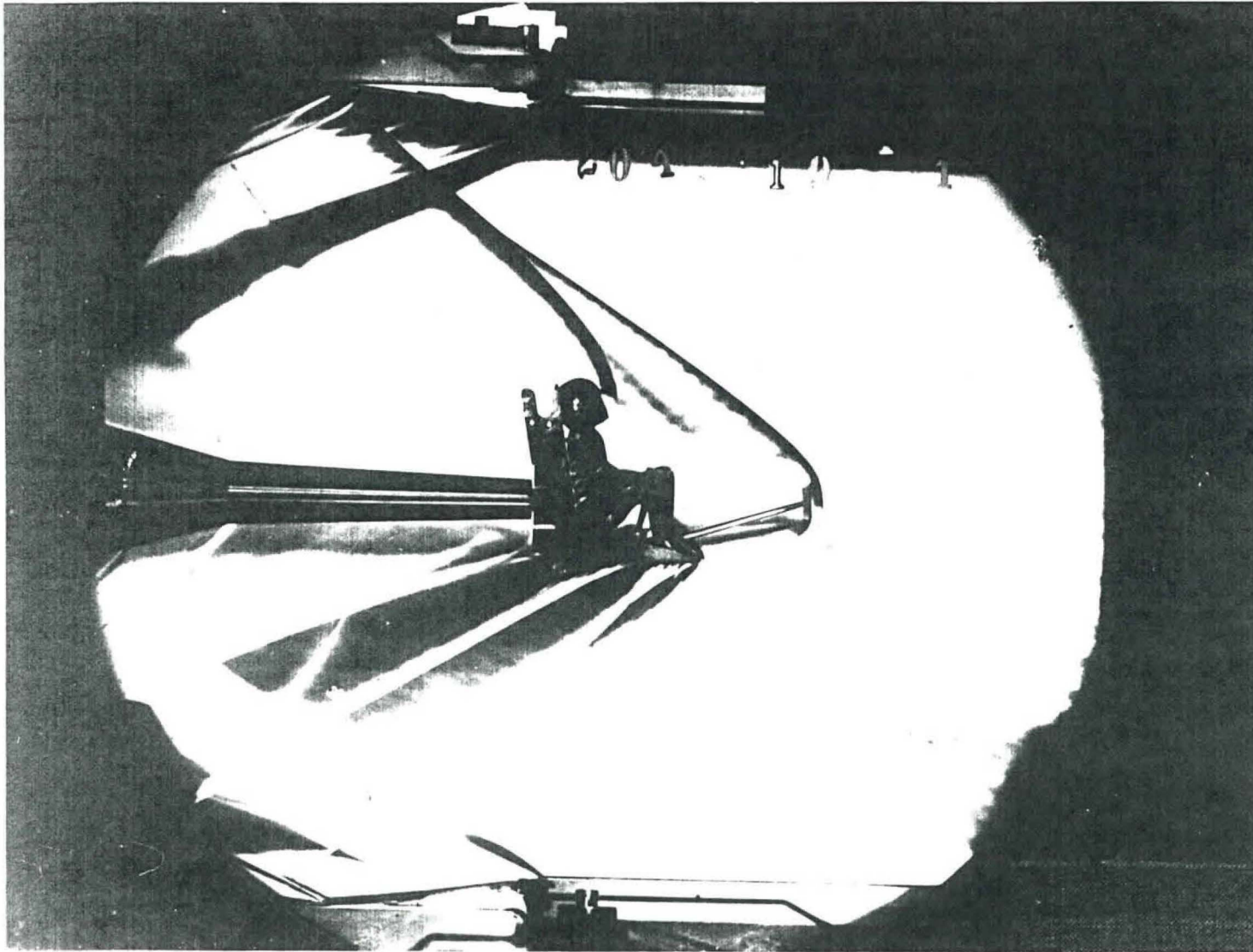

FIG. 49

Lockheed AIRCRAFT CORPORATION

CALIFORNIA DIVISION

provide for escape at high takeoff and approach speeds, but the principles that have been developed for the Lockheed "D" seat can be applied to upward ejection seats and a good over-all escape system provided without the use of capsules.

E. Spin and Rate of Roll Requirements

It is quite difficult for the supersonic airplane configuration to comply with certain existing spin requirements developed over many years for subsonic configurations. Likewise, the ability of the short span supersonic airplanes to obtain fantastically high rates of roll produces unnecessary problems in inertia coupling, structural design, etc. A revision to these requirements is long overdue. It is not reasonable to expect our newer fighters to make six-turn normal spins and, should they be forced to comply with such regulations, it will in all likelihood result in modifications that will be costly in performance and weight. The writer recommends that the incipient conditions for spinning and spin provision be given the emphasis, rather than wasting a great deal of time and effort on forcing our newer configurations to meet obsolete requirements. Roll rates should be limited to those practical in combat, without encountering rates of roll which may be as high as 300° to 400° per second.

F. Boundary Layer Control Development

In addition to the boundary layer control studies made in

~~CONFIDENTIAL~~
Lockheed AIRCRAFT CORPORATION

CALIFORNIA DIVISION

connection with pitchup, the F-104A was studied with various forms of boundary layer control for an increase in maximum lift. Figure 50 shows the use of the blowing system for flow control over the trailing edge flaps. This system is standard on all production airplanes. A decrease in stalling speed of approximately 15 mph can be obtained with this system. Further development using boundary layer control behind the leading edge flap shows excellent promise. The straight thin wing is very adaptable to obtaining good increases from such boundary layer control devices, while this is not always possible with other wing planforms. This wing planform has the further advantage that high lifts are obtained at relatively low angles of attack, so that problems of visibility in approach and landing are not encountered.

G. Electronic Development

As previously explained, it was possible to make an efficient lightweight fighter only by making improvements in the weight and size of such things as armament, powerplant, and electronic and radar gear. In the case of the gunsight, it was recognized at an early date that radar was required to extend the pilot's vision in search, as it would be absolutely impossible, at the high speeds to be used, to depend on normal vision alone. A proposal was made to the Air Force whereby the development of a lightweight radar and gunsight would be undertaken, and this was approved. The

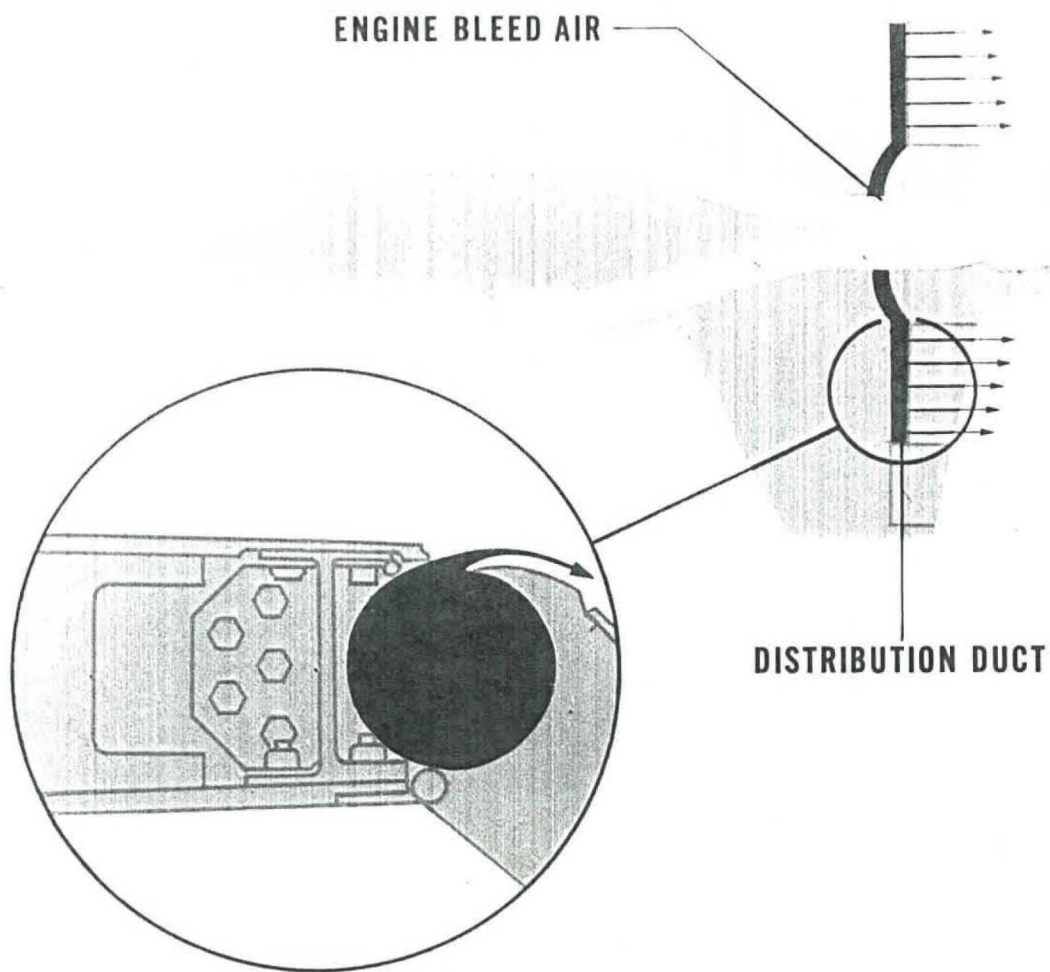

BOUNDARY LAYER CONTROL SYSTEM

FIG. 50

~~CONFIDENTIAL~~

Lockheed AIRCRAFT CORPORATION

CALIFORNIA DIVISION

MA-10 system evolved, weighing less than half of other fighter radar and gunsight developments. Infrared was provided for sighting at night. The performance of the airplane is so high, however, that radar ranges obtained are not fully suitable for completely solving the problems of air-to-air search and tracking.

In the field of communications and navigation equipment, repackaging of these units and incorporation of built-in test equipment is going forward. While it has not been possible, to this time, to reduce greatly the weight of this gear, there have been important advances made in maintainability and general arrangement from an installation point of view.

~~CONFIDENTIAL~~
Lockheed AIRCRAFT CORPORATION

CALIFORNIA DIVISION

VII. GENERAL DESCRIPTION OF F-104A AND F-104B

With the foregoing as an introduction, outlining the reasons for using the basic configuration and equipment, it is in order to show the over-all outcome of the design problems referred to. Figures 51 through 55 are self-explanatory and show the general arrangement of the F-104A and some of its systems. Provision was made in the initial aircraft layout to provide for a two-place, tandem seating, trainer version of the aircraft. This tactical trainer has performance practically identical to the fighter, except for range, and will no doubt be a very useful machine to insure good training programs for the tactical airplane (Figure 56).

Various other developments, having to do with carrying external stores, missiles, range extension devices, and similar features, have been made, but will not be described at this time.

The foregoing summary covers developments leading up to the actual service indoctrination of the F-104A, encompassing some 4700 wind tunnel tests and a vast number of design studies and developments, such as it takes to make a modern fighter.

LIGHTWEIGHT SEARCH RADAR

OPTICAL & INFRARED SIGHT

ELECTRONICS COMPARTMENT

AMMUNITION

J-79 ENGINE WITH AFTERBURNER

SADDLE TANKS

RADAR INDICATOR

T-171E3 GUN

SUMP TANK

ARRESTOR CHUTE

DOWNWARD EJECTION SEAT

AUXILIARY TANK

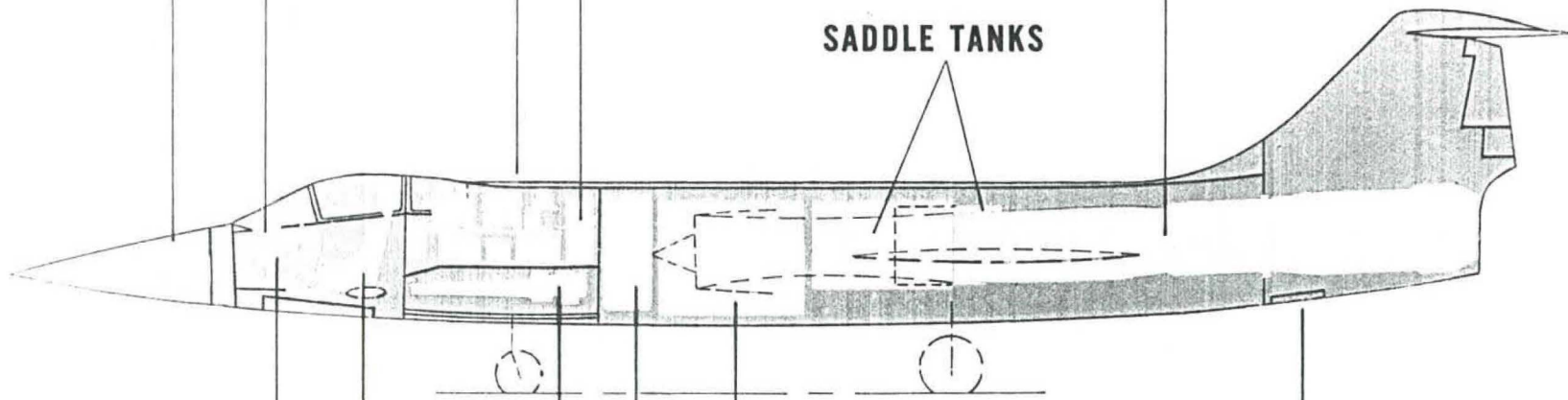

F-104A FIGHTER ARRANGEMENT

FIG. 51

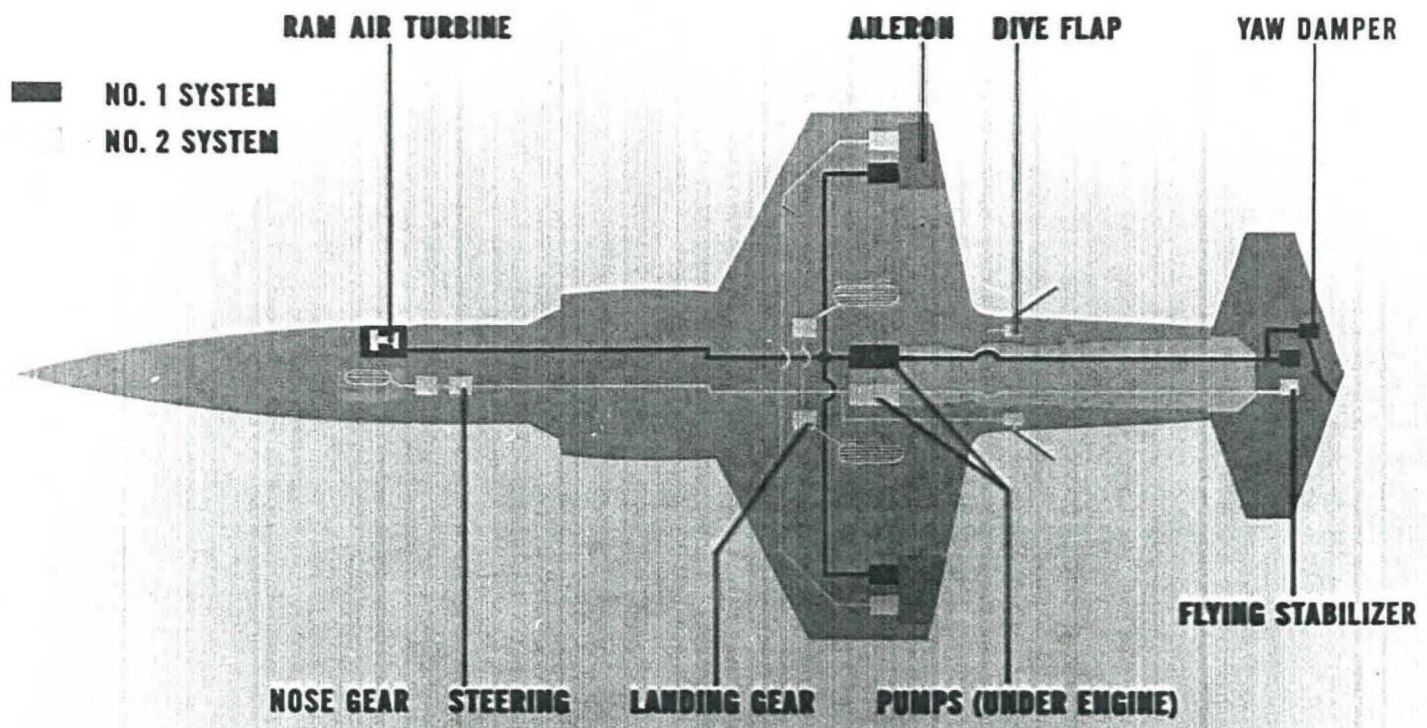

HYDRAULIC SYSTEM

FIG. 52

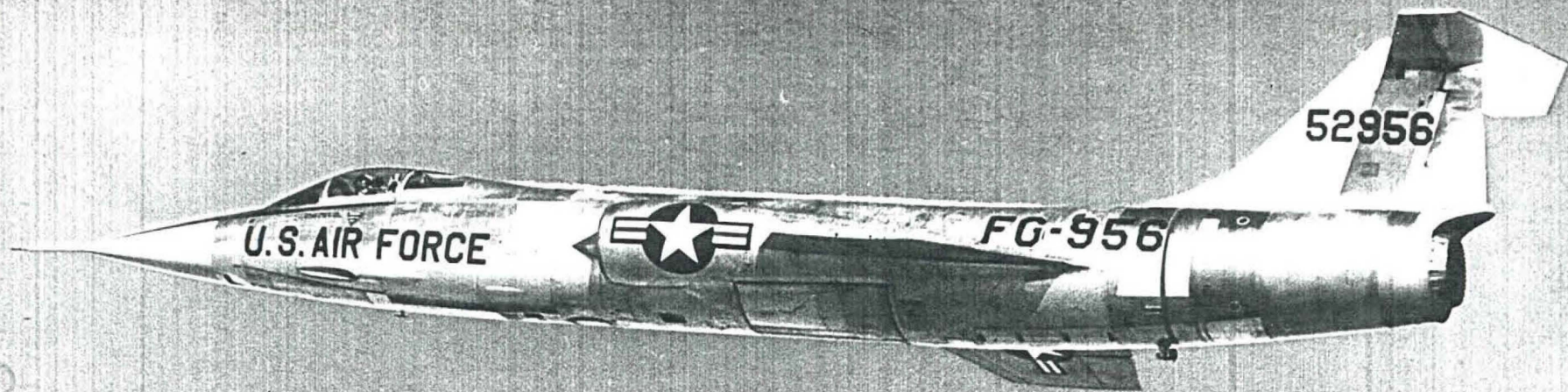

~~CONFIDENTIAL~~

~~CONFIDENTIAL~~

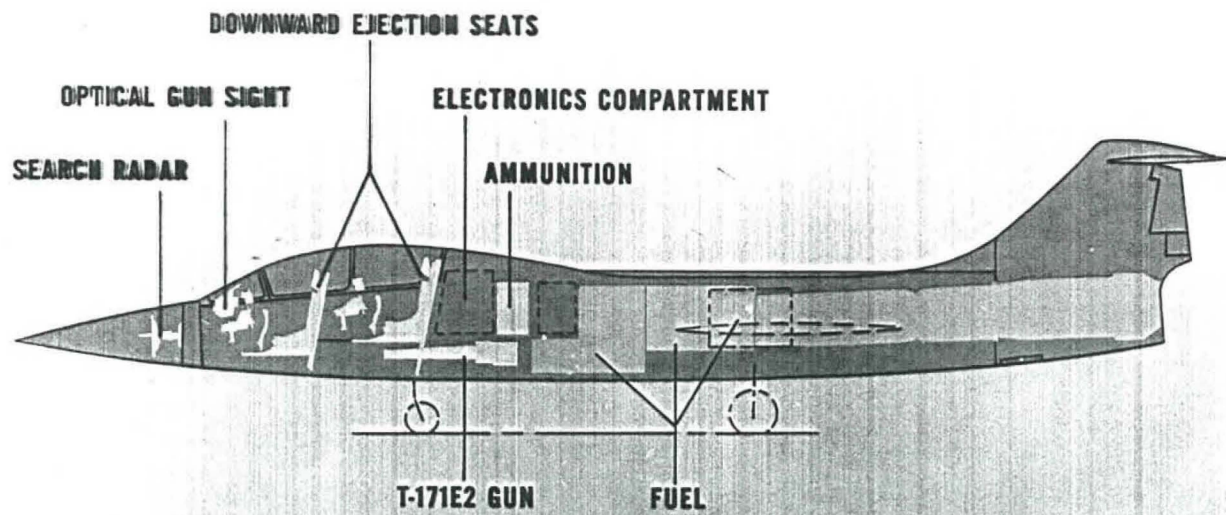

TWO-PLACE ARRANGEMENT

FIG.56

Lockheed AIRCRAFT CORPORATION

CALIFORNIA DIVISION

VIII. LOOKING FORWARD

What direction should forward progress take in the fighter field? Should we have more speed? More altitude? We have reached the state where our fighters are essentially "manned missiles." We have probably outstripped our ground radar control system and our airborne radar for search and firing. We have gotten to the point where the thrust/weight ratio of the F-104A is very close to 1.0 and it is becoming feasible, from that point of view, to consider the vertical takeoff and landing configuration. It is very difficult to see where added high speed is worthwhile, and it appears that the development of armament, radar, and fire control systems is the most fruitful field for our research efforts over the next five years.

Prop-
Pheny