

412TW-PA-22217



**SOME THOUGHTS ON TESTING THE DATA QUALITY
METRIC**

KIP TEMPLE

**AIR FORCE TEST CENTER
EDWARDS AFB, CA**

JUNE 2022

**4
1
2
T
W**

**APPROVED FOR PUBLIC RELEASE DISTRIBUTION STATEMENT A:
DISTRIBUTION IS UNLIMITED.**

**412TH TEST WING
EDWARDS AIR FORCE BASE, CALIFORNIA
AIR FORCE MATERIEL COMMAND
UNITED STATES AIR FORCE**

REPORT DOCUMENTATION PAGE

Form Approved
OMB No. 0704-0188

Public reporting burden for this collection of information is estimated to average 1 hour per response, including the time for reviewing instructions, searching existing data sources, gathering and maintaining the data needed, and completing and reviewing this collection of information. Send comments regarding this burden estimate or any other aspect of this collection of information, including suggestions for reducing this burden to Department of Defense, Washington Headquarters Services, Directorate for Information Operations and Reports (0704-0188), 1215 Jefferson Davis Highway, Suite 1204, Arlington, VA 22202-4302. Respondents should be aware that notwithstanding any other provision of law, no person shall be subject to any penalty for failing to comply with a collection of information if it does not display a currently valid OMB control number. **PLEASE DO NOT RETURN YOUR FORM TO THE ABOVE ADDRESS.**

| | | | | | |
|---|------------------------------------|--|---|---|---|
| 1. REPORT DATE (DD-MM-YYYY) 10-06-2022 | | 2. REPORT TYPE Technical Paper | | 3. DATES COVERED (From - To) | |
| 4. TITLE AND SUBTITLE SOME THOUGHTS ON TESTING THE DATA QUALITY METRIC | | | | 5a. CONTRACT NUMBER | |
| | | | | 5b. GRANT NUMBER | |
| | | | | 5c. PROGRAM ELEMENT NUMBER | |
| 6. AUTHOR(S) Temple, Kip | | | | 5d. PROJECT NUMBER | |
| | | | | 5e. TASK NUMBER | |
| | | | | 5f. WORK UNIT NUMBER | |
| 7. PERFORMING ORGANIZATION NAME(S) AND ADDRESS(ES) AND ADDRESS(ES) 812 AITS 307 E. Popson Ave Edwards AFB CA 93561 | | | | 8. PERFORMING ORGANIZATION REPORT NUMBER 412TW-PA-22217 | |
| 9. SPONSORING / MONITORING AGENCY NAME(S) AND ADDRESS(ES) 412th Test Wing 195 E Popson Ave Edwards AFB CA 93524 | | | | 10. SPONSOR/MONITOR'S ACRONYM(S) N/A | |
| | | | | 11. SPONSOR/MONITOR'S REPORT NUMBER(S) | |
| 12. DISTRIBUTION / AVAILABILITY STATEMENT Approved for public release Distribution Statement A: distribution is unlimited | | | | | |
| 13. SUPPLEMENTARY NOTES Source Code 012100 (This number comes from STINFO via EAFB Technical Library) CA: 412 th Test Wing, Edwards AFB, CA | | | | | |
| 14. ABSTRACT Over the last several years, Test and Training Ranges have been upgrading their telemetry receiving capabilities by integrating hardware that implement many of the link improvement techniques standardized within IRIG 106. One of these techniques is Data Quality Encapsulation (DQE) that includes the Data Quality Metric (DQM). The DQM assigns a quality metric to a set of data without a priori knowledge of the data. This metric can be highly useful if it accurately describes the quality of the data. This paper presents some initial thoughts on potential test methods that could aid in the determination of DQM accuracy. The approaches center on the use of differing transmission channels to corrupt the telemetry signal and then compare the estimated quality with the actual quality. | | | | | |
| 15. SUBJECT TERMS Data Quality Metric, Data Quality Encapsulation, Best Source Selection, bit error probability, bit error rate, E _b /N ₀ | | | | | |
| 16. SECURITY CLASSIFICATION OF: Unclassified | | | 17. LIMITATION OF ABSTRACT None | 18. NUMBER OF PAGES 12 | 19a. NAME OF RESPONSIBLE PERSON 412 TENG/EN (Tech Pubs) |
| a. REPORT Unclassified | b. ABSTRACT Unclassified | c. THIS PAGE Unclassified | | | 19b. TELEPHONE NUMBER (include area code) 661-277-8615 |

SOME THOUGHTS ON TESTING THE DATA QUALITY METRIC

Kip Temple

Air Force Test Center, Edwards AFB CA

ABSTRACT

Over the last several years, Test and Training Ranges have been upgrading their telemetry receiving capabilities by integrating hardware that implement many of the link improvement techniques standardized within IRIG 106. One of these techniques is Data Quality Encapsulation (DQE) that includes the Data Quality Metric (DQM). The DQM assigns a quality metric to a set of data without a priori knowledge of the data. This metric can be highly useful if it accurately describes the quality of the data. This paper presents some initial thoughts on test methods that could aid in the determination of the validity and accuracy of this metric. The approaches center on the use of differing transmission channels to corrupt the telemetry signal and then compare the estimated quality with the actual quality.

KEY WORDS

Data Quality Metric, Data Quality Encapsulation, Best Source Selection, bit error probability, bit error rate, E_b/N_0

INTRODUCTION

If you were to canvas the vendors that supply telemetry receivers, you would come across a feature not available just a few years ago. Receivers of today have the ability to assess the quality of the output data after reception and demodulation without a priori knowledge of the input data. The Telemetry Group (TG) of the Range Commanders Council (RCC) quickly realized the ability to assess data quality after reception of encrypted data would be of great benefit to Test and Training Ranges performing aeronautical mobile telemetry (AMT) missions. In response to this revolutionary advancement in receive technology, the RCC/TG standardized a protocol for transferring a packet of data with an associated quality metric [1]. This is all well and good, but how well do these receivers actually characterize the output data quality in a challenging AMT transmission environment? Can this new metric even be trusted to give accurate results? This paper will discuss some thoughts on potential tests that could be used to assess how well the data quality metric characterizes the output data of a telemetry receiver.

BACKGROUND

The RCC/TG standardized a protocol to ensure future interoperability of hardware that would use this new data quality metric. This protocol is referred to as data quality encapsulation (DQE) which defines the frame structure for the transmission of the data payload with the data quality metric (DQM) value associated with that payload. For the purposes of this paper, we will focus on the DQM.

The one defining metric for data quality is bit error rate (BER), i.e. how many bits are in error over a given range of data or time. In order to assess this error rate, the originally transmitted data is compared to the received data on a bit-by-bit basis to determine if the received bit was in error. For telemetry links,

DISTRIBUTION STATEMENT A. Approved for public release; Distribution is unlimited 412TW-PA-

XXXXX

unless a known pseudo-random bit sequence (PRBS) of a defined length is transmitted, a BER calculation is not possible as the originally transmitted data is not known. In this case where the transmitted data is not known, the next best metric for assessing data quality is determining the probability that a bit is in error. Telemetry receivers in the market place today are able to make this probability determination of the data output from the receiver. Transmitting this probability estimation directly using the DQE protocol would be difficult to express so the BEP is converted to an n -bit word prior to the encapsulation. This conversion is detailed in [1] and repeated here for reference. The DQM value is calculated from the estimated BEP as follows:

$$DQM = \frac{-\log_{10}(LR)}{k} * 2^n \tag{1}$$

where: k is the exponent for lowest estimated BEP
 n is number of bits in the DQM field
 LR is the likelihood ratio

$$LR = \frac{BEP}{(1-BEP)} \tag{2}$$

For most receivers and real-world applications to date, $k=12$ and $n=16$. Table 1 illustrates the calculation of LR and DQM for values of BEP given these values of k and n .

| BEP Verses DQM | | |
|----------------|-------------|-------|
| BEP | LR | DQM |
| 0.5 | 1.00 | 0 |
| 1e-01 | 1.11111e-01 | 5211 |
| 1e-02 | 1.01010e-02 | 10898 |
| 1e-03 | 1.00100e-03 | 16381 |
| 1e-04 | 1.00010e-04 | 21845 |
| 1e-05 | 1.00001e-05 | 27306 |
| 1e-06 | 1.00000e-06 | 32767 |
| 1e-07 | 1.00000e-07 | 38229 |
| 1e-08 | 1.00000e-08 | 43690 |
| 1e-09 | 1.00000e-09 | 49151 |
| 1e-10 | 1.00000e-10 | 54613 |
| 1e-11 | 1.00000e-11 | 60074 |
| 1e-12 | 1.00000e-12 | 65535 |

Table 1 – Bit Error Probability versus Data Quality Metric

There is now a standard way of sending DQM via a DQE protocol. Why is the transmission of an estimation of data quality important? It is important for several reasons. One, a standard method of transmission ensures that sources and sinks of this information are interoperable. Second, the data quality information can be used for several downstream applications not realized before this information was available. For example, real-time display of link quality is now available to consumers of real-time telemetry. Telemetry link performance can now be logged and recorded during missions allowing post

mission link analysis. But perhaps the most important application is using the DQM value as the selection metric for best source selection (BSS). Best source selectors have been in existence for a many years and have used several suboptimal selection metrics such as majority vote or PCM frame sync. These metrics both have shortcomings. Not until the introduction of DQM did the BSS have a decision metric that was actually based upon the data being sent (via DQE) to the BSS. Today, best source selectors implement a maximum likelihood bit detector (MLBD) scheme as described in [2] in combination with multiple stream correlation to optimally choose the best source on a bit by bit basis with very good results [7]. The key to assigning a DQM value is an accurate and consistent estimate of the bit error probability that applies to the data that follows the estimate. The DQM must be relevant for all channel conditions or sources of signal corruption that may exist during telemetry operations.

Accurate and consistent DQM values are important concepts and should not be overlooked. Some Test Ranges use telemetry receivers from a single vendor exclusively. In this case, consistent results between receiver 1 through receiver n should be expected though accurate results still should be tested. But this exclusive use is not prevalent at all Test Ranges. Some use a combination of two, three, or more receiver products from differing vendors. In this case, both vendor-to-vendor consistency along with accuracy should be tested. This is especially true when multiple vendor receivers are feeding a single best source selector. Imagine the extreme case where a receivers DQM=65535 regardless of output data quality, the downstream best source selector would always select this source!

THE AMT TRANSMISSION CHANNEL AND SIGNAL DEGRADATION SOURCES

Before thinking about tests that would characterize the performance validity of the data quality estimate, a cursory understanding of the AMT transmission channel is required. In a typical application, the telemetry signal is transmitted from the test article and is received at the ground station antenna. As the signal propagates between test article and ground station, it can undergo corruption. This corruption is due to a combination of many mechanisms within the transmission channel that are determined by frequency, distance, antenna patterns, geometry, geography, etc. These mechanisms can generally be broken into two categories that limit telemetry system performance in that channel: noise and multipath. As distance between transmitter and receiver increases, the ratio of signal-to-noise decreases until noise dominates the channel resulting in bit errors and ultimately signal loss. Multipath is predominately due to the surrounding geography and geometry between the transmitter and receiver. The multiple paths the signal can take from the transmitting antenna to the receiving antenna in an AMT environment is modeled with a channel model as defined in [3].

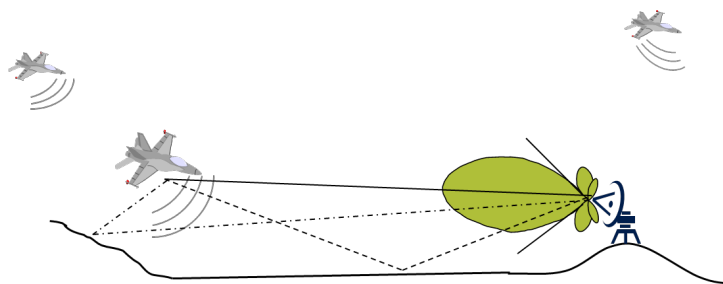

Figure 1 – Typical Aeronautical Mobile Telemetry Scenario

As systems under test increase in complexity and in numbers, less day-to-day AMT spectrum is available to accommodate real-time transmission of test data. Greater complexity results in higher over-

the-air data rates. Coupled with the sheer number of tests and increasing test tempo result in AMT spectrum scheduling congestion. Regulatory actions and spectrum auctions have resulted in commercial wireless systems operating in and adjacent to AMT spectrum. All of these conditions result in potential in-band adjacent channel interferers as well as out-of-band interference.

The next section will discuss tests to assess how well the receiver is estimating signal corruption based on these limiting channel conditions generally characterized as additive noise, multipath, and adjacent channel interference.

THOUGHTS ON TESTING

The telemetry link is limited by channel conditions that include additive noise, multipath fading, and at times, interference. The reception of the signal can also be affected by anomalies in test article antenna patterns or ground station antenna tracking. The result of these sources of signal corruption and degradation should be the basis for the proposed tests. The goal is for the test to emulate a real-world signal corruption event, then measure how well the receiver estimates the actual output bit error rate via a bit error probability estimation after reception and demodulation. To illustrate these thoughts, here are a few examples of conditions that should be considered when thinking about appropriate DQM testing:

- Additive noise will start dominating the received signal as the distance between test article and receiving station increase. This results in lower and lower signal-to-noise ratios until the transmitted signal is unrecoverable.
- Depending upon the bandwidth of the transmitted signal and the multipath condition, a complete signal fade could occur during a multipath event.
- A low flying test article transmitting a high data rate telemetry signal in a mountainous environment could result in frequency selective multipath conditions.
- Deep nulls in the composite antenna pattern from the test article would cause signal fading at the receiver. At long slant ranges the result of the fading could result in the signal abruptly transitioning between values of system BER. This fading could also cause the receive antenna to lose track of the test article for some amount of time resulting in signal loss and receiver resynchronization.

In [4] Hill proposed multiple DQM "calibration" tests using much the same thought process as this paper; since no standardized method exists on how to determine a DQM value, testing must be done to characterize receiver DQM performance. This paper builds upon those initial thoughts and proposes a series of tests by leveraging existing test methods [5, 6] and the telemetry channel model [3]. Throughout the tests described below, a comparison of DQM (BEP) against BER, captured and compared over the same interval of time, is used as the performance metric. Lastly, coding in the form of forward error correction and Space-Time Coding and their effect on the tests are briefly discussed. Both add a level of complication to all of the test methods described below as DQE payload lengths are tied to the block structure of the coding schemes [1].

Limiting Channel Condition – Additive Noise (BER versus BEP)

The first, and perhaps easiest test to consider is one where the signal is corrupted by additive white Gaussian noise (AWGN). This is indicative of many flight scenarios where the test article flies near the limit at which point noise starts to dominate the signal, in other words the limiting channel condition is

noise. The test method in [6] can be leveraged to provide a starting point for this test method. The receiver should be able to provide a BEP that is a very good estimate of BER for the AWGN case. In general, the test method can be described with the following steps using the test set up as shown in Figure 2:

1. Create the test signal/waveform with the desired modulation/coding, pseudo random bit sequence (PRBS), at the required data rate.
2. Corrupt the signal with a known level of AWGN thus setting E_b/N_0 for the signal.
3. Measure receiver output BER by varying input E_b/N_0 .
4. While measuring BER derived from the DQE payload, simultaneously capture and record the corresponding DQM values. Calculate BEP from the DQM values.
5. Plot BER vs E_b/N_0 and BEP vs. E_b/N_0 and compare results.

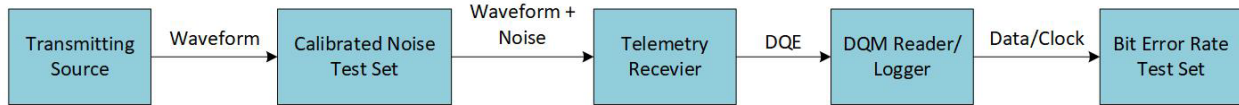

Figure 2 – Notional Test Set Up (Additive Noise, BER vs. BEP)

The result of this test illustrates the detection performance of the receiver for the input modulation/coding selected. While an excellent figure of merit, what is important for this test is how well the BEP vs. E_b/N_0 curve matches the BER vs. E_b/N_0 curve. Ideally, the two curves should sit on top of each other.

Limiting Channel Condition – Flat Fading (resynchronization response)

This test method provides a means to characterize the receiver’s signal quality estimate during a resynchronization event where the link is either impaired with additive noise or is not. For the case where noise is added, this scenario could occur when the test article is operating at longer slant ranges at low antenna elevation angles, i.e. an aircraft flying low over the ocean at a distance that is stressing the link budget. This case would exhibit low signal-to noise ratios coupled with a multipath severe environment causing flat fades (complete signal loss) and antenna tracking issues. For the case where no additive noise is added (the link is not noise limited), the test article would be operating at a shorter range where multipath or test article antenna pattern nulls are now limiting performance causing signal losses to the receiver. The purpose is to investigate any anomalous or erroneous DQM values output from the receiver during a resynchronization event. The basis of comparison is the DQM value versus BER before, during, and after a resynchronization event. For both cases, the input signal to the receiver will have a known, fixed signal quality resulting in a known BER. In the case of no additive noise, BER would be zero corresponding to a DQM value of 65535 (see Table 1).

In general, the test method can be described with the following steps using the test set up shown in Figure 3:

1. Create the test signal/waveform with the desired modulation/coding using a PRBS as the baseband data set to the desired bit rate.
2. For testing with AWGN, set E_b/N_0 as required. For testing without additive noise, bypass the noise test set.

3. To simulate a signal outage, step between signal (or signal + noise) and noise by adjusting the RF switching time with the switching source. Adjust the signal outage rate as required to fully characterize the receiver's DQM resynchronization response.
4. While measuring BER derived from the DQE payload, simultaneously capture and record the corresponding DQM values as the signal to the receiver is switched between signal (or signal + noise), noise, then back to signal (or signal + noise).
5. Calculate BEP from DQM and plot the calculated BEP estimates with BER throughout the switching cycle.
6. Repeat the test at different values of E_b/N_0 as required.

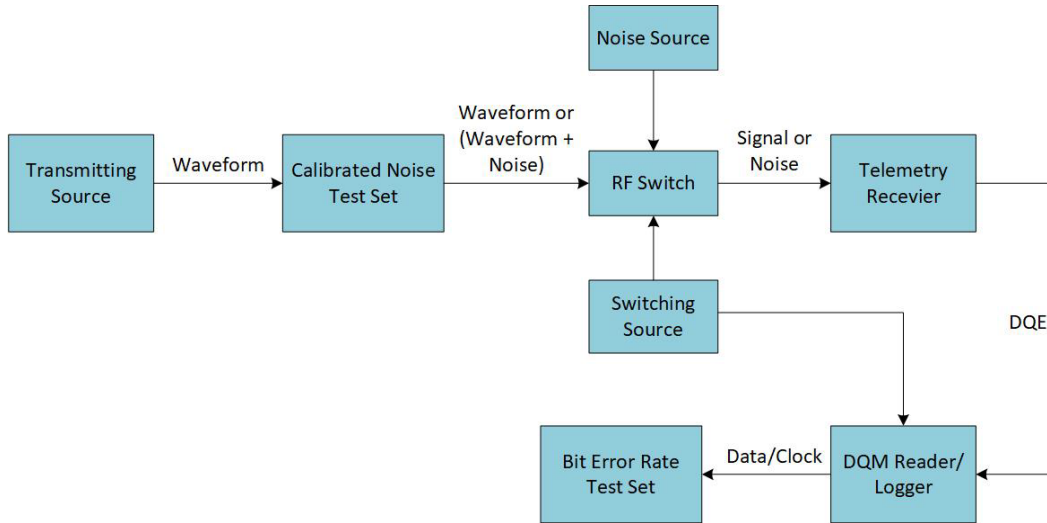

Figure 3 – Notional Test Set Up (Resynchronization Response)

It is worth mentioning that there are a few practical considerations associated with this test. During resynchronization, the number of DQE payload bits may not match the number of transmitted bits due to the resynchronization process. Something else to consider is if IRIG-compliant low density parity check code (LDPC) is applied. In this case, both the demodulator and LDPC decoder have to resynchronize. In this case, the DQE payload should be synchronized to the LDPC codeblock [1] that could lead to some anomalous behavior depending upon the receiver strategy for outputting DQE frames during resynchronization. The same discussion is true if Space Time Coding is added.

Limiting Channel Condition – Additive Noise in a Flat Fading Channel (DQM step and dwell)

The goal of this test would be to characterize the accuracy, relevancy, and response of the receiver's BEP estimate in a dynamic channel condition with differing amounts of additive noise. This test differs from the one above test. In this test the link is operating in a region where bit errors are evident and the switching of the signal does not cause the receiver to resynchronize. This channel condition is probably not representative of a real-world channel condition that occurs a lot, rather it is intended to test the correlation of DQM to the data payload in the DQE frame. To test this scenario, a test setup is required that will cyclically step and dwell through several values of input signal E_b/N_0 while simultaneously recording DQM and BER values from the receiver. The timing of the capture is important, the BER and DQM need to correspond to the same payload of information. The test method in [6] related to

resynchronization testing can be used as a starting point for developing the concepts used in this test method.

This test is intended to illustrate whether or not the DQM values directly applies to the payload in the same DQE frames. This is vitally important for downstream equipment, such as a best source selector, that is making decisions on the payload quality. If the DQM value is not directly applicable or relevant to the data payload in the DQE frame(s) or is averaged over a huge number of multiple DQE frames, the decisions made within the BSS on which source to select will be in error as the DQM values are not representative of the data. The faster the cycle rate through E_b/N_0 values the more apparent whether or not the DQM value applies to the data payload over the exact same number of DQE frames.

The test method can generally be described with the following steps using the test set up in Figure 4:

1. Create the test signal/waveform with the desired modulation/coding, PRBS, at the required data rate.
2. Corrupt the signal with a known level of AWGN thus setting E_b/N_0 for the signal.
3. Continually step between several values of E_b/N_0 that result in a BER ranging between 1×10^{-2} to 1×10^{-7} . For example, for SOQPSK modulation, E_b/N_0 could step and dwell between values of 5, 8, 12, 8, 5, 8, 12, etc.
4. Vary the dwell time (step frequency) between steps in E_b/N_0 . The dwell time could range between 10-1000 DQE frames before switching to the next value.
5. Capture and record results comparing dwell time with measured DQM (BEP) vs actual BER values for the values of E_b/N_0 used during the test. It is critical that the BER and DQM (BEP) be measured simultaneously on the exact same DQE frames.
6. Plot BEP estimates with BER values versus the number of DQE data payloads captured as the test cycles through each E_b/N_0 setting.

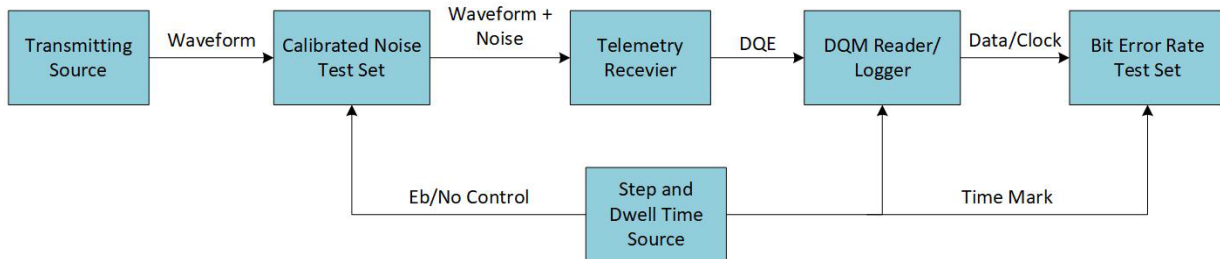

Figure 4 – Notional Test Set Up (DQM Step and Dwell)

Every DQE frame has an expected number of bit errors based on DQM and an actual number of bit errors as calculated to determine the BER. This can be illustrated by comparing the calculated number of expected bit errors, as determined by the DQM value, with actual bit errors measured. Granted, depending upon the BER and data rate, a bit in error may not be present for several DQE frames. For this case, it is highly likely the DQM value applies to several DQE frames.

Limiting Channel Condition – Adjacent Channel Interference (BER versus BEP)

The goal of this test would be to characterize the how accurately the receiver estimates the output signal quality in the presence of adjacent channel interference. In a bandwidth constrained environment typical of an environment most test ranges face today, telemetry signals are scheduled as close in frequency as

possible trading the maximum number of users with interference. Even with this rigorous scheduling, interference can exist either with other unscheduled telemetry signals, non-telemetry signal in-band interferers, or out-of-band adjacent signals. For example, strong cellular signals can exist as adjacent band interferers, Wireless Communication Service (WCS) signals can exist as in-band S-Band interferers, and unscheduled users of telemetry spectrum can all cause interference. All of these scenarios can be derived allowing a comparison of estimated BEP versus measured BER. The test method in [6] related to ACI can be used as a starting point for developing the concepts used in this test method.

The test method can generally be described with the following steps using the test set up in Figure 5:

1. Create the “carrier” or “victim” waveform with the desired modulation/coding using a PRBS as the baseband data at the desired data rate. Corrupt the carrier signal with AWGN to an E_b/N_0 level 1dB above a resulting BER of 1×10^{-5} .
2. Choose an interferer. If a telemetry signal, choose the waveform with the desired modulation/coding and data rate. If a cellular-type signal, choose the type of signal present in the environment to be simulated.
3. Set carrier to interference (C/I) ratio. For telemetry signals, C/I is typically -20dB. For other interfering signals, C/I is dictated by the environment to be simulated.
4. At the C/I for the test, determine the frequency offset of the interfering signal that results in a carrier BER = 1×10^{-5} . This frequency offset results in 1dB of carrier signal degradation and will be used as the “center point” for dithering the interfering signal frequencies.
5. Capture and record carrier DQM (BEP) and BER values while the interferer is dithered in frequency around the center point resulting in a range of BER values between 1×10^{-2} to 1×10^{-7} .
6. Calculate BEP from DQM values, tabulate results and plot BEP and BER as a function of interferer offset frequency to illustrate the results.

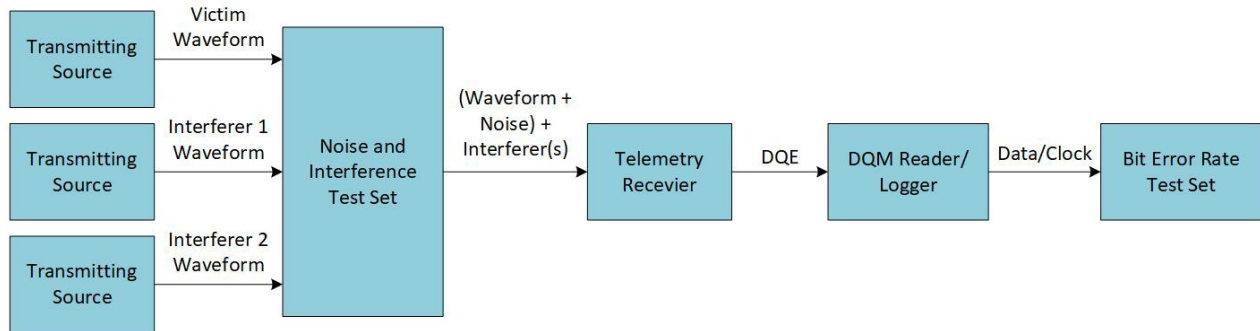

Figure 5 – Notional Test Set Up (ACI, BER vs. BEP)

Limiting Channel Condition – Multipath (BER versus BEP, static 3-ray channel)

Any telemetry channel described using the channel model in [3] will use three propagation paths, or transmission rays, to describe the impulse response of the channel. The three paths are line-of-site (LOS) direct path, the specular reflection path, and the diffuse reflection path. The severity, or how much the multipath channel degrades the signal, depends upon the characteristics of the specular and diffuse reflection paths. The goal of this test is to determine how well the BEP estimate characterizes or tracks the actual system BER under three real-world static multipath conditions as defined in [5]. These multipath channel conditions are generally described as mild, moderate, and severe.

Using the three static 3-ray multipath conditions, measure the BER of the given combination of waveform/coding under test. Depending upon the multipath sensitivity of the waveform or waveform/coding combination under test, one or more of the multipath channels may be too severe for the receiver/decoder to synchronize to and provide a valid output. Unlike a system corrupted by AWGN that provides predictable results (i.e. gradual degradation of BER as increasing levels of noise is added), a signal corrupted by multipath must be tested for each multipath condition presented. Once the multipath channels are determined, BER and DQM (BEP) can then be captured and compared.

In general, the test method can be described with the following steps using the test set up in Figure 6:

1. Create the waveform with the desired modulation or modulation/coding using a known bit pattern (PRBS) at the desired bit rate.
2. Create one of the three (mild, moderate, severe) static 3-ray multipath channel conditions. The multipath condition will cause waveform distortion leading to corruption in system BER.
3. While measuring BER derived from the DQE payload, simultaneously capture and record the corresponding DQM values for each of the three static channel conditions.
4. Calculate BEP from DQM values and compare the BEP with the actual BER.

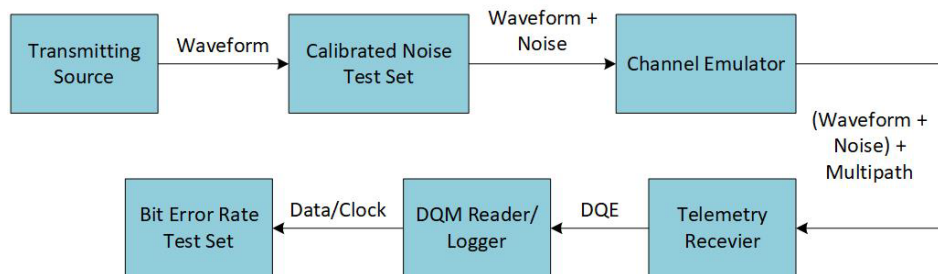

Figure 6 – Notional Test Set Up (Multipath, BER vs. BEP)

Limiting Channel Condition – Multipath (BER versus BEP, static 2-ray channel)

Much like the static 3-ray test described above, this test is used to determine how well the BEP estimate from the telemetry receiver characterizes or tracks the actual system BER while being subjected to multiple static multipath conditions. Unlike the test described above, this test uses only 2-rays but uses multiple settings of amplitude, relative delay, and phase of the specular reflection path to increase or decrease the severity of the multipath channel [5]. In total, there are over 150 different settings available to create any level of severity required. The test set up, test method, and result comparison is much the same as the 3-ray static multipath case described above.

WHAT YOU SHOULD GET OUT OF THIS PAPER

- The Test Ranges require standardized test methods to ensure receiver output data quality is assessed both contently and accurately.
- Test Ranges that use telemetry receivers from multiple vendors and perform best source selection using DQM as a selection metric are keenly interested in standard test methods.
- Standardized test methods can add confidence in the data quality estimate as it applies to the data packet that follows the estimate as defined in [1].
- Several of the existing test methods in IRIG 118 Vol 2 can be leveraged to provide the basis for test methods specific to DQM evaluation.

- Throughout the notional tests described above, there was a key piece of test equipment introduced generally described as the “DQM Reader/Logger”. This reader/logger would have the following functionality:
 - Capture incoming DQE packets
 - Log DQM values and calculate BER using the same DQE payload
 - Accept external time mark into log file
 - Output data and clock derived from the DQE payload by “de-framing” the payload in the DQE frame
- Even under the worst fading conditions where DQM values may or may not be valid, correlating best source selectors do an amazing job of providing a best source.

ACKNOWLEDGEMENTS

A special thanks to the Telemetry Group of the Range Commanders Council and the member Ranges for funding this work through the Telemetry Group Engineering Support Task. The author would also like to thank the following technical contributors not only to this paper but also for their continued technical support of AMT systems:

Edwards AFB: Bob Selbrede; Quasonix: Terry Hill, Jim Uetrecht; Safran Data Systems: Tim Cole

REFERENCES

1. Secretariat, Range Commander Council, *”Standards for Data Quality Metrics and Data Quality Encapsulation”*, RCC Document IRIG 106 Chapter 2, Appendix 2-G, <https://www.trmc.osd.mil/wiki/display/publicRCC/Public+RCC+Home>
2. Rice, Michael. Perrins, Erik. *”Maximum Likelihood Detection from Multiple Bit Sources”*, International Telemetry Conference Proceedings, October 2015
3. Secretariat, Range Commander Council, *”Dynamic Multipath Channel for Aeronautical Mobile Telemetry”*, RCC Document IRIG 106 Chapter 2, Appendix 2-H, <https://www.trmc.osd.mil/wiki/display/publicRCC/Public+RCC+Home>
4. Hill, Terry. *”Metrics and Test Procedures for Data Quality Estimation in the Aeronautical Telemetry Channel”*, International Telemetry Conference Proceedings, October 2015
5. Secretariat, Range Commander Council, *”Test Procedures for Implementing Multipath Channel Conditions”*, RCC Document IRIG 118 Chapter 10, <https://www.trmc.osd.mil/wiki/display/publicRCC/Public+RCC+Home>
6. Secretariat, Range Commander Council, *”Test Procedures for Telemetry Demodulators”*, RCC Document IRIG 118 Chapter 7, <https://www.trmc.osd.mil/wiki/display/publicRCC/Public+RCC+Home>
7. Uetrecht, Jim. *”Dual-Channel Receiver Performance Using Best Channel Selection: Field Test Results”*, International Telemetry Conference Proceedings, October 2019
8. Uetrecht, Jim. *”Obtaining Superior Performance From Dual –Channel Receivers Using Best Channel Selection”*, International Telemetry Conference Proceedings, October 2018
9. Rice, Michael. *Digital Communications – A Discrete-Time Approach*. Pearson Prentice Hall 2009
10. Proakis, John G. *Digital Communications*. McGraw Hill 1995