

AWARD NUMBER: W81XWH-17-1-0022

TITLE: Assistive and Autonomous Breast Ultrasound Screening:  
Improving PPV and Reducing RSI

PRINCIPAL INVESTIGATOR: Thomas Howard

CONTRACTING ORGANIZATION: University of Rochester, Rochester, NY

REPORT DATE: September 2021

TYPE OF REPORT: **FINAL**

PREPARED FOR: U.S. Army Medical Research and Materiel Command  
Fort Detrick, Maryland 21702-5012

DISTRIBUTION STATEMENT: Approved for Public Release;  
Distribution Unlimited

The views, opinions and/or findings contained in this report are those of the author(s) and should not be construed as an official Department of the Army position, policy or decision unless so designated by other documentation.

# REPORT DOCUMENTATION PAGE

*Form Approved*  
*OMB No. 0704-0188*

Public reporting burden for this collection of information is estimated to average 1 hour per response, including the time for reviewing instructions, searching existing data sources, gathering and maintaining the data needed, and completing and reviewing this collection of information. Send comments regarding this burden estimate or any other aspect of this collection of information, including suggestions for reducing this burden to Department of Defense, Washington Headquarters Services, Directorate for Information Operations and Reports (0704-0188), 1215 Jefferson Davis Highway, Suite 1204, Arlington, VA 22202-4302. Respondents should be aware that notwithstanding any other provision of law, no person shall be subject to any penalty for failing to comply with a collection of information if it does not display a currently valid OMB control number. **PLEASE DO NOT RETURN YOUR FORM TO THE ABOVE ADDRESS.**

<b>1. REPORT DATE</b> September 2021			<b>2. REPORT TYPE</b> Final		<b>3. DATES COVERED</b> 01Feb2017-31May2021	
<b>4. TITLE AND SUBTITLE</b>  Assistive and Autonomous Breast Ultrasound Screening: Improving PPV and Reducing RSI					<b>5a. CONTRACT NUMBER</b> W81XWH-17-1-0022	
					<b>5b. GRANT NUMBER</b> W81XWH-17-1-0022	
					<b>5c. PROGRAM ELEMENT NUMBER</b>	
<b>6. AUTHOR(S)</b>  Stephen McAleavey, Thomas Howard  E-Mail: <a href="mailto:stephen.mcaleavey@rochester.edu">stephen.mcaleavey@rochester.edu</a> <a href="mailto:thoward@ece.rochester.edu">thoward@ece.rochester.edu</a>					<b>5d. PROJECT NUMBER</b>	
					<b>5e. TASK NUMBER</b>	
					<b>5f. WORK UNIT NUMBER</b>	
<b>7. PERFORMING ORGANIZATION NAME(S) AND ADDRESS(ES)</b>  University of Rochester Rochester, NY 14627					<b>8. PERFORMING ORGANIZATION REPORT NUMBER</b>	
<b>9. SPONSORING / MONITORING AGENCY NAME(S) AND ADDRESS(ES)</b>  U.S. Army Medical Research and Materiel Command Fort Detrick, Maryland 21702-5012					<b>10. SPONSOR/MONITOR'S ACRONYM(S)</b>	
					<b>11. SPONSOR/MONITOR'S REPORT NUMBER(S)</b>	
<b>12. DISTRIBUTION / AVAILABILITY STATEMENT</b>  Approved for Public Release; Distribution Unlimited						
<b>13. SUPPLEMENTARY NOTES</b>						
<b>14. ABSTRACT</b> This report describes all research activities on technologies that support sonographer-supervised robotic systems for breast ultrasound imaging with qualitative elastography, quantitative elastography, and shear-wave elastography for this grant.						
<b>15. SUBJECT TERMS</b> None listed.						
<b>16. SECURITY CLASSIFICATION OF:</b>			<b>17. LIMITATION OF ABSTRACT</b>	<b>18. NUMBER OF PAGES</b>	<b>19a. NAME OF RESPONSIBLE PERSON</b>	
<b>a. REPORT</b>	<b>b. ABSTRACT</b>	<b>c. THIS PAGE</b>			<b>19b. TELEPHONE NUMBER</b> (include area code)	
Unclassified	Unclassified	Unclassified	Unclassified	28	USAMRMC	

## Table of Contents

	<u>Page</u>
<u>1. Introduction .....</u>	<u>4</u>
<u>2. Keywords .....</u>	<u>4</u>
<u>3. Accomplishments .....</u>	<u>4</u>
<u>4. Impact .....</u>	<u>20</u>
<u>5. Changes/Problems .....</u>	<u>21</u>
<u>6. Products .....</u>	<u>22</u>
<u>7. Participants &amp; Other Collaborating Organizations .....</u>	<u>25</u>
<u>8. Special Reporting Requirements .....</u>	<u>28</u>
<b>9. Appendices .....</b>	<b>none</b>

## **1. Introduction**

The objective of this research project is to develop technologies that support sonographer-supervised robotic systems for breast ultrasound imaging with quantitative elastography. Elastography provides tissue metrics independent of B-mode image features to deliver improved lesion classification, but current techniques are hampered by sensitivity to variations in probe motion and pressure, resulting in significant operator dependence. By delivering advanced, operator-independent elastography data, the proposed system will address the urgent need to improve the positive predictive value (PPV) of ultrasound to spare women unnecessary biopsies, anxiety, and cost while maintaining quality of care. The main goals in the third and fourth years of the project have been to develop and experimentally verify novel algorithms for robotically assisted breast ultrasound imaging.

## **2. Keywords**

Ultrasound elastography, breast cancer, robotics, human-robot teaming

## **3. Accomplishments**

### **3.1 What were the major goals of the project**

The overall goal of this research is to investigate technologies for improving the positive predictive value (PPV) of ultrasound screening. The specific aims for this research include development and evaluation of a collaborative robotic system for breast ultrasound scanning and elastography (SA1) and perform experiments with robotically assisted elastography (SA2). Year 1-2 focused on developing technologies to support human-robot ultrasound scanning systems, while Years 3-5 transitioned towards studies and refinement of the collaborative robotic system and ultrasound imaging techniques.

### **3.2 What was accomplished under these goals**

The early years of this research proposal focused on the development of a robotically assisted ultrasound scanning system. The system we developed primarily consisted of a Rethink Robotics Sawyer Collaborative Robot and a Robotiq FT300 Force/Torque (FT) Sensor that controlled the position, orientation, and applied force of an 3D printed end-effector that encapsulated a L11-4v ultrasound probe connected to a Verasonics Vantage 64 LE ultrasound scanner. An illustration of a control architecture described in our 2018 IEEE International Conference on Biomedical Robotics and Biomechatronics paper that accepted desired velocities and forces of the end-effector is illustrated below in Figure 1. Software for this system was written in C++ and MATLAB and used ROS for interprocess communication and CMake as the software build system.

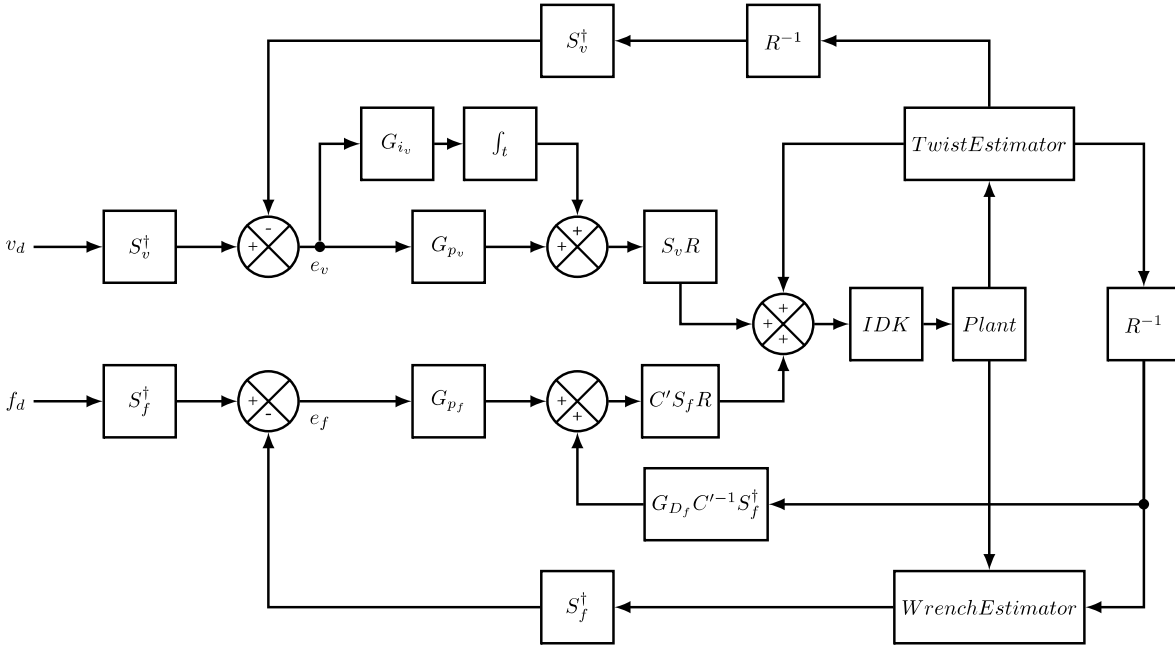

Figure 1: A block diagram illustrating an early hybrid force/velocity controller for robotically assisted ultrasound scanning implemented on our Rethink Robotics Sawyer Collaborative Robot.

Figure 2 shows human positioning of the ultrasound transducer using the wrist cuff buttons of the Rethink Robotics Sawyer Collaborative Robot. After experimenting with several different approaches for providing user input for controlling the end-effector position and orientation and initiation of the scanning procedure, the wrist cuff buttons were observed to be most intuitive and naturally used the gravity compensation mode of control of the Sawyer Collaborative Robot. In these early experiments we evaluated the responsiveness of the implemented control architecture and ability to reject disturbances akin to those that might occur from natural respiration or movement of a human subject.



Figure 2: Images showing positioning and experiments with the robotically assisted ultrasound scanning of a tissue phantom.

Following the initial implementation of the robotically assisted ultrasound scanning system, we developed a method to estimate uncertainty of an approach to qualitative quasi-static strain

elastography. This idea used Gaussian filters that are commonly applied for probabilistic mapping approaches for robotic systems to fuse information from robot sensors and the ultrasound transducer to produce a measure of the confidence of the resulting elastogram. Images representative of experiments described in our 2019 International Symposium on Robotics Research paper on qualitative elastography approaches to robotically assisted ultrasound scanning are illustrated in Figure 3.

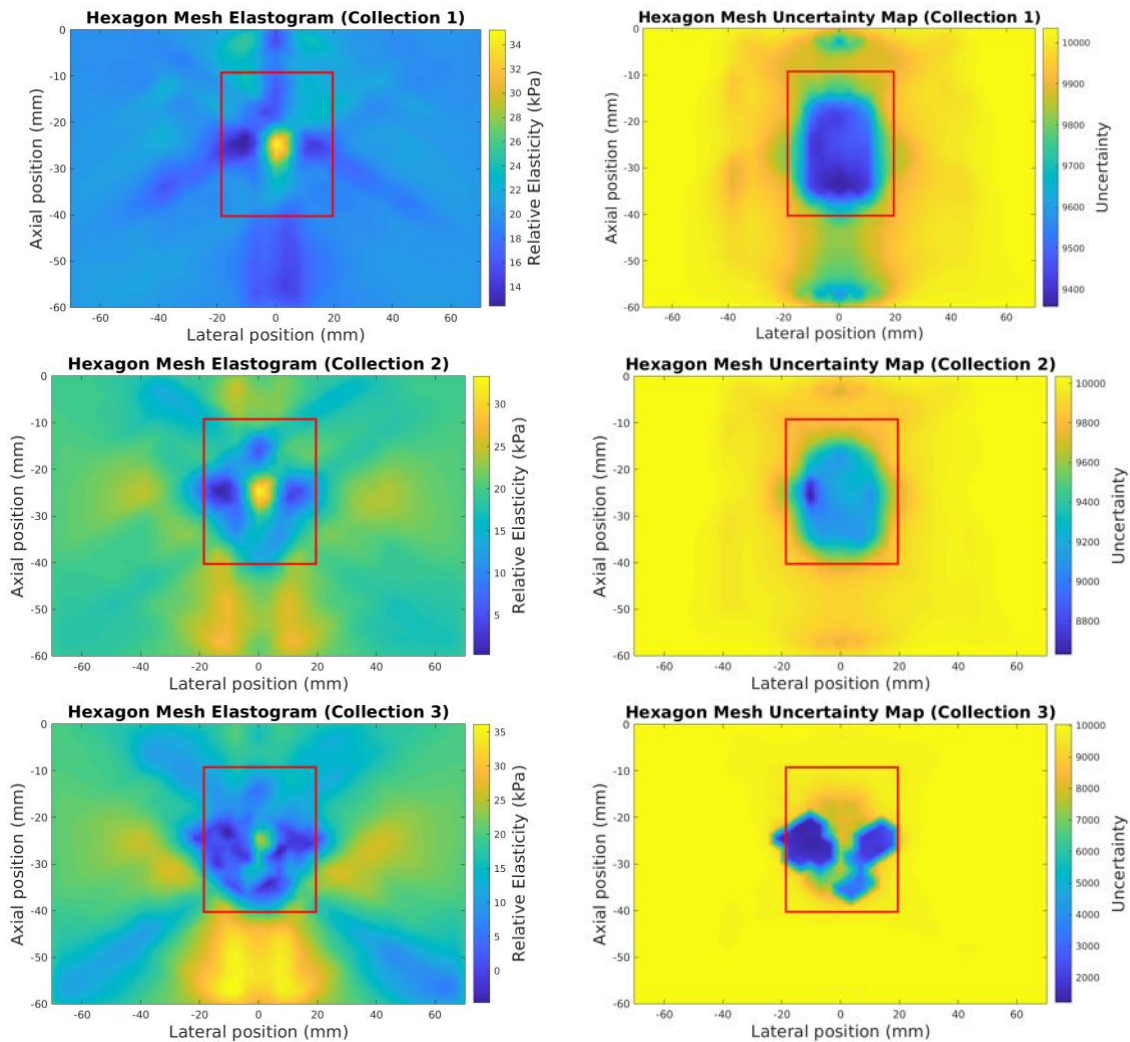

Figure 3. Reconstructed elastograms (left) and uncertainty maps (right) for three data acquisitions using the developed approach to qualitative elastography.

Recent activities involving robotically assisted compressional elastography were focused primarily on the extension of the stochastic qualitative elastography approach to quantitative, by including data from a force/torque sensor mounted at the robot's wrist. The original framework presented in our paper "Probabilistic mapping of tissue elasticity for robot-assisted medical ultrasound" that was presented at the 2019 International Symposium on Robotics Research was used directly by incorporating a new measurement model for the FT sensor. However, the initial results were highly degraded by reconstruction artifacts due to the models we originally selected

for experiments with both homogeneous and inclusion fabricated gelatin phantoms as shown in Figure 4.

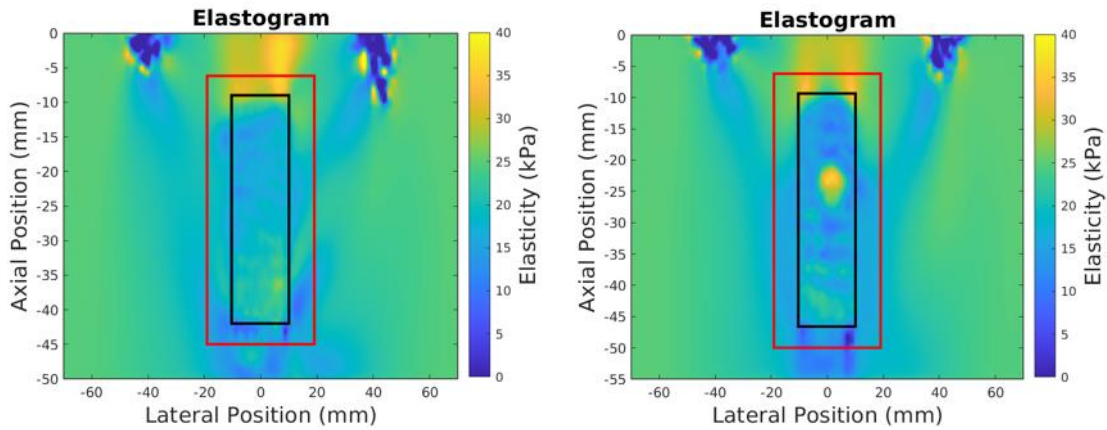
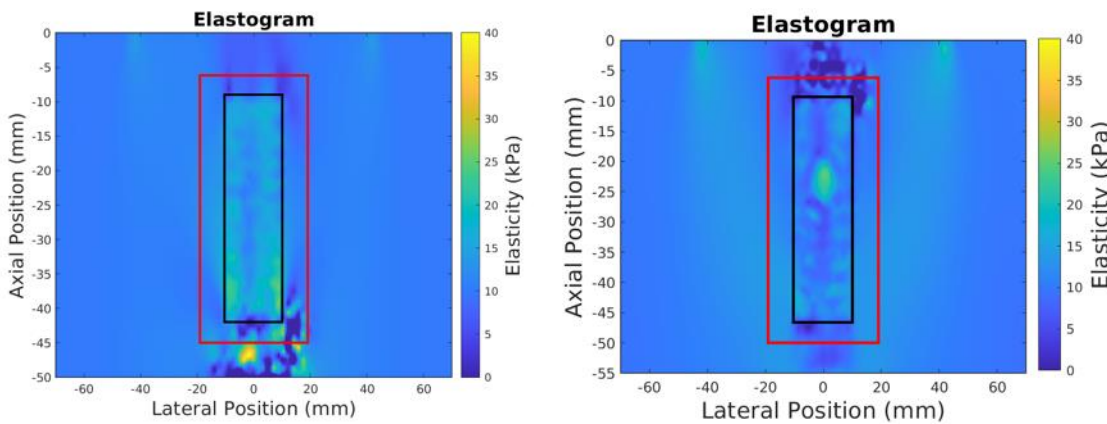

Figure 4. Nominal resulting elastograms on homogeneous (left) and inclusion (right) phantoms obtained by direct application of the stochastic elastography approach developed in the previous year. While the inclusion and background elasticities agree with the measurements made by the MTS machine, the reconstructions are seriously degraded outside of the field of view (black rectangle).

The results of this process were highly dependent on the initial assumption for tissue elasticity. The background was measured to be approximately 16kPa and the inclusion roughly 40kPa, which agrees with the resulting elastograms when the initial elasticity assumption was “close”, which in this case was 25 kPa. However, when the algorithm was applied with initial elasticities of either 10kPa or 40 kPa, the results are significantly degraded as shown in Figure 5.



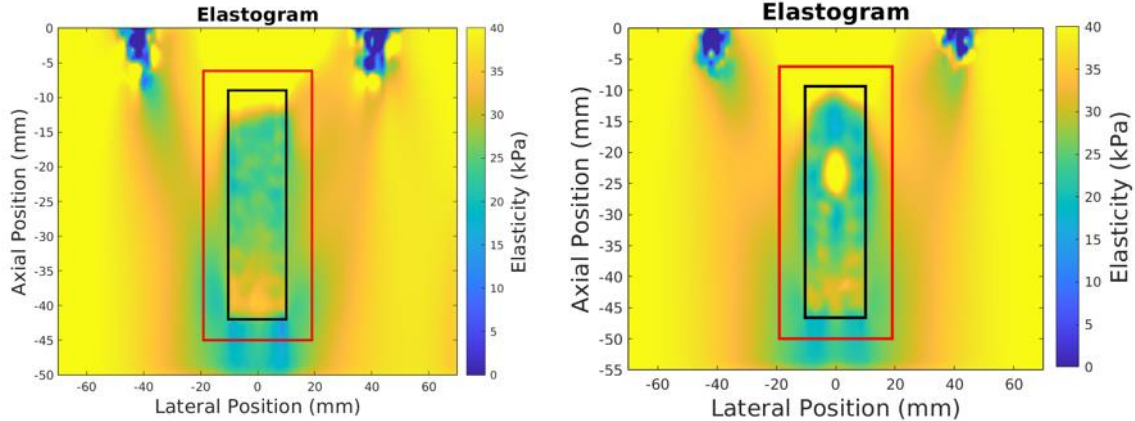

Figure 5. Resulting elastograms when the initial elasticity is assumed to be 10kPa (top row) and (40kPa) bottom row for the homogeneous (left column) and inclusion (right column) phantoms. In addition to many artifacts the resulting elastograms are noisy inside the Field of View (FOV) and have a significantly higher error in absolute elasticity.

The experiments were repeated for three trials on each phantom for a total of six data collections with 200 ultrasound image pairs and thousands of force/torque and joint encoder measurements acquired per collection. The final mean elasticities of the inclusion and backgrounds are shown in Figure 6. The figures show significant dependence on the initial elasticity assumption and the reconstructed value. This is a significant practical disadvantage as good estimates of the biomechanical tissue properties in patients may not be readily available.

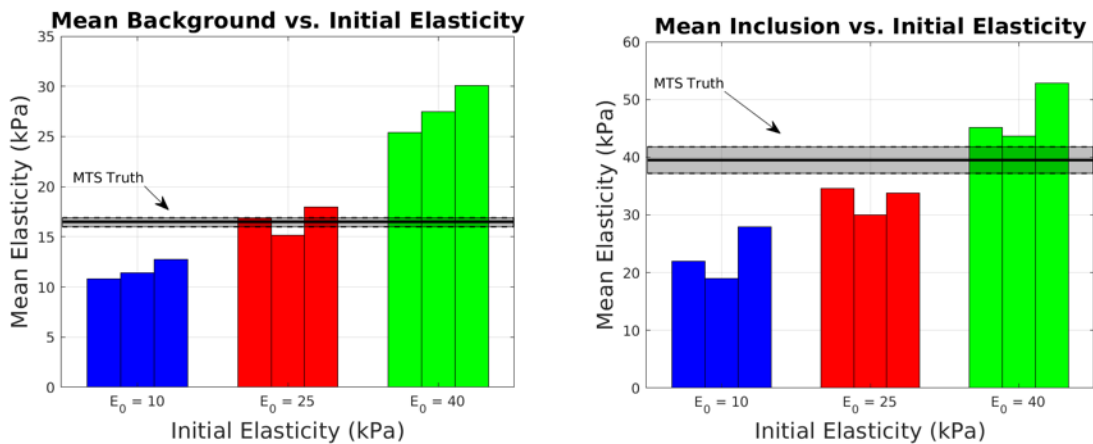
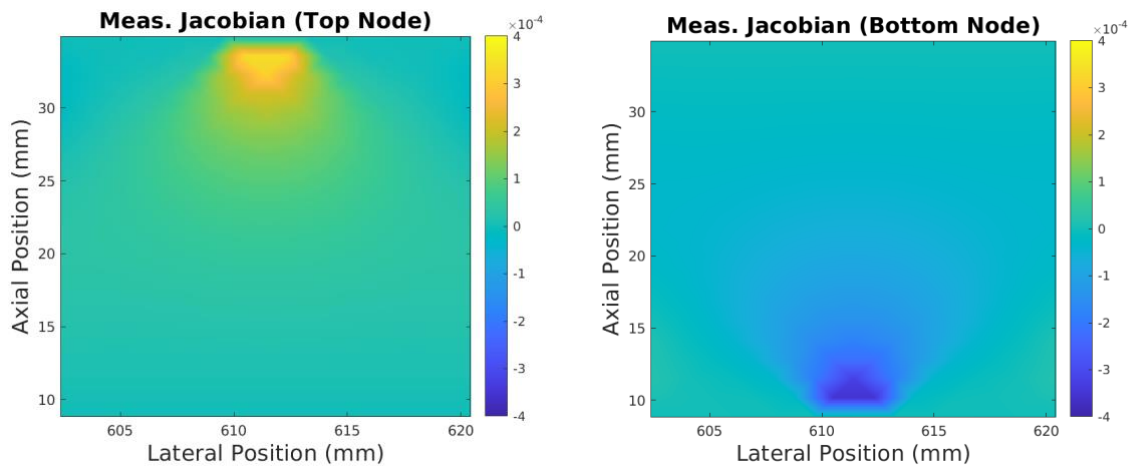

Figure 6. Average background (left) and inclusion (right) elasticities over all trials and initial conditions. Results with an initial elasticity of 25kPa are closer to the background and inclusion elasticities as measured by the MTS machine. Results obtained with the initial assumption of 10kPa underestimate both the inclusion and background elasticities. Conversely, results obtained with an initial assumption of  $E = 40$ kPa overestimate both phantoms.

Although the results from Figure 6 show reasonably accurate reconstruction with a close initial elasticity assumption, the greater limitation of this approach is that there is no clear objective to discern which results are accurate in practice. This challenge prevents leveraging a multi-

hypothesis approach since no appropriate comparison metric could be identified. As such, it was determined that an update to the map state vector would be required to address these shortcomings. This included the addition of an absolute elasticity scaling variable in the map vector which would provide a bias during construction of the elastograms. All nodes in the Finite Element Model (FEM) mesh contained variables representing relative differences from this scale factor. Additionally, a new measurement model which predicts the normal force based on this scale factor and the penetration depth into the tissue by the end-effector was employed instead of the previous full FEM model. This measurement model facilitates the computation of a Jacobian with significantly fewer quantitative variables with the intent of improving robustness to poor initial assumptions.

In addition to the updated force measurement model and map state vector, the FOV was restricted to include only a region encapsulated by the reconstructed ultrasound coordinates. This reduced the number of degrees of freedom which were unobserved during the mapping process (anything outside of the black rectangles in Figures 4 and 5). This led to the discovery of an additional complication due to the nature of the displacement measurement model Jacobian. In essence, while there are displacement measurements to balance state variable updates for nodes in the center of the FOV, these observations are absent on the top and bottom of the mesh as shown in Figure 7.



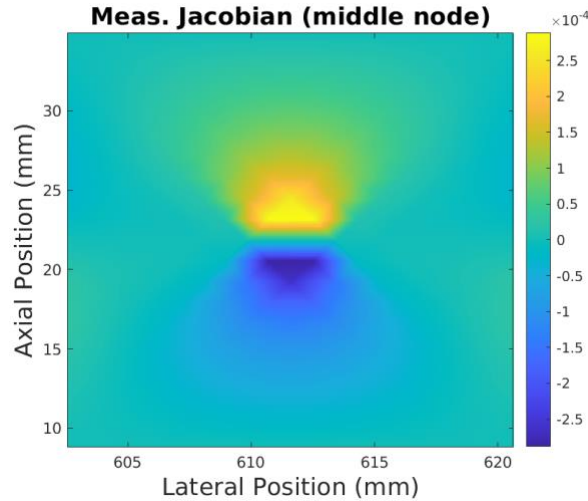

Figure 7. Visualization of the displacement measurement model’s asymmetrical nature for a node at the top of the FEM mesh (top left), bottom (top right), and center (bottom). Brighter and darker regions represent displacement predictions which experience more contribution from the current node’s relative elasticity. Note that there is an equal contribution above and below the center node, which is not present for nodes on the mesh boundaries. Furthermore, there are no displacement observations for the areas outside of these regions which would normally contribute when updating the estimated elasticity values for these nodes.

The asymmetrical nature of the displacement measurement model Jacobian can be illustrated using the visualizations of said Jacobian in Figure 7. These images represent the sensitivity of a displacement prediction to the relative elasticity of the node being considered (either at the top, bottom, or center of the mesh). The center node (at the bottom of this figure) has a larger impact on the displacement predictions than nodes at the top or bottom. Furthermore, there are measured displacements above and below the center node to help determine the appropriate update for this relative elasticity. However, for nodes on the boundaries, there are only observations on one side. For example, while softening the tissue may help resolve displacements below the top node, there is additional tissue above this node which is not being considered and may affect how the elasticity would otherwise be updated. Fortunately, this asymmetry can be mitigated by choosing a sub-FOV where the Jacobians are mostly balanced as shown in Figure 8. Any nodes outside of this region are initialized with low uncertainty, which is equivalent to high confidence that they are homogeneous in these regions.

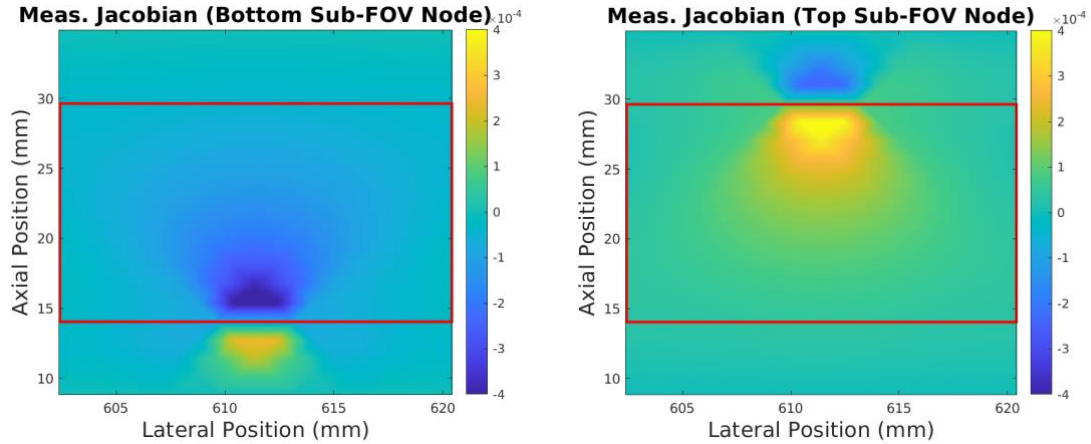

Figure 8. Sub-windows are used to mitigate the effects of the asymmetrical nature of the displacement measurement model Jacobian. The Jacobians inside these windows are mostly balanced and have observations of the tissue both above and below each node inside the sub-window.

When the sub-windows are not employed, the resulting quantitative reconstruction is severely degraded. In two out of three trials on inclusion phantoms, the stochastic elastography approach failed to converge. Convergence was achieved in the third trial; however, the quantitative value of the inclusion was significantly lower than the MTS measured (40kPa). The resulting elastogram is shown in Figure 9.

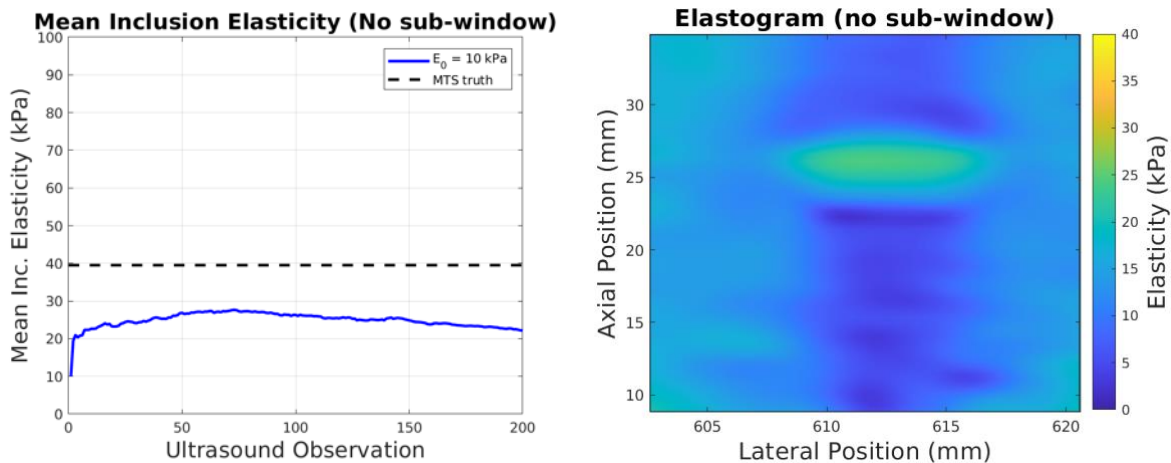

Figure 9. Average inclusion elasticity per ultrasound data observation (left) and resulting elastogram (right) on gelatin inclusion phantom without applying a sub-window to mitigate the effect of the displacement measurement model Jacobian's asymmetry. Although qualitatively the presence of an inclusion is detectable in the resulting elastogram, its absolute elasticity value is significantly different from the MTS measured (20kPa vs. 40kPa).

The results in Figure 9 and our observations of the asymmetry of the displacement measurement model Jacobian led us to believe that the latter was detrimental to the quantitative results. We hypothesized that effect of the displacement measurement model Jacobian

asymmetry could be mitigated using a sub-window-based approach as shown by the resulting elastograms in Figure 10. The flat regions at the top and bottom are outside of the sub-windows illustrated in Figure 8 and were therefore primarily unmodified during the reconstruction.

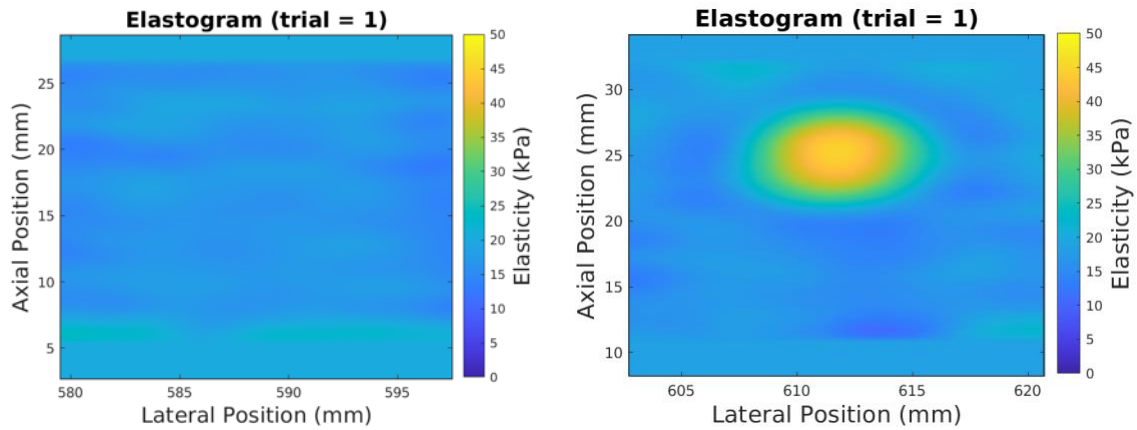

Figure 10. Resulting quantitative elastograms obtained using the stochastic elastography method on homogeneous (left) and an inclusion (right) gelatin phantom. The measured elasticity for both the background and inclusion are within 5 kPa of the measured MTS values.

The experiment was repeated over both phantoms for three trials at three different initial elasticity assumptions (10kPa, 50kPa, and 100kPa) to evaluate the algorithm's resilience against poorly initialized models. The convergence of the mean inclusion elasticity of each initial condition for each trial is shown in Figure 11. The results for the background elasticity are shown in Figure 12.

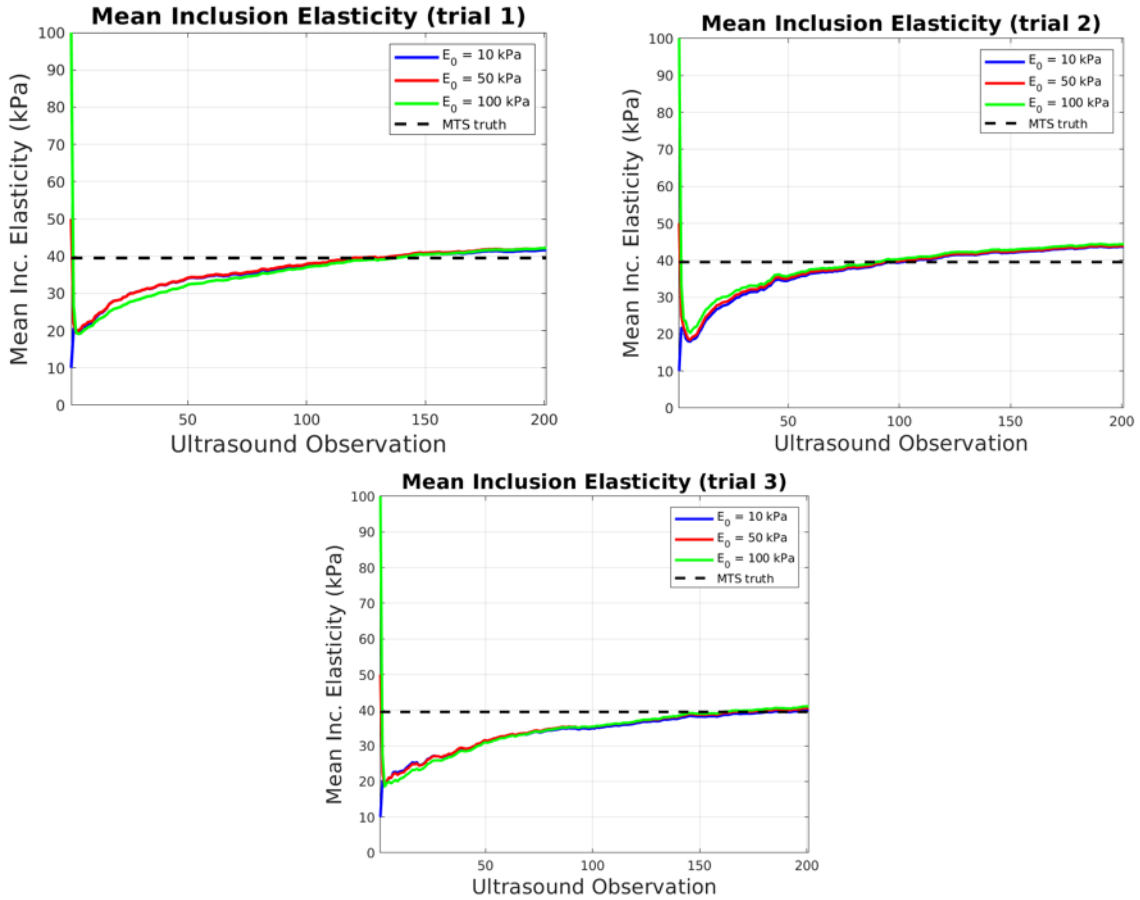

Figure 11. Convergence plots for the resulting mean inclusion elasticities initialized at 10kPa, 50kPa, and 100kPa respectively. Regardless of the analyzed initial elasticity assumption, the algorithm converges to within 5kPa of the measured MTS values. This indicates a degree of resilience against poor initial assumptions

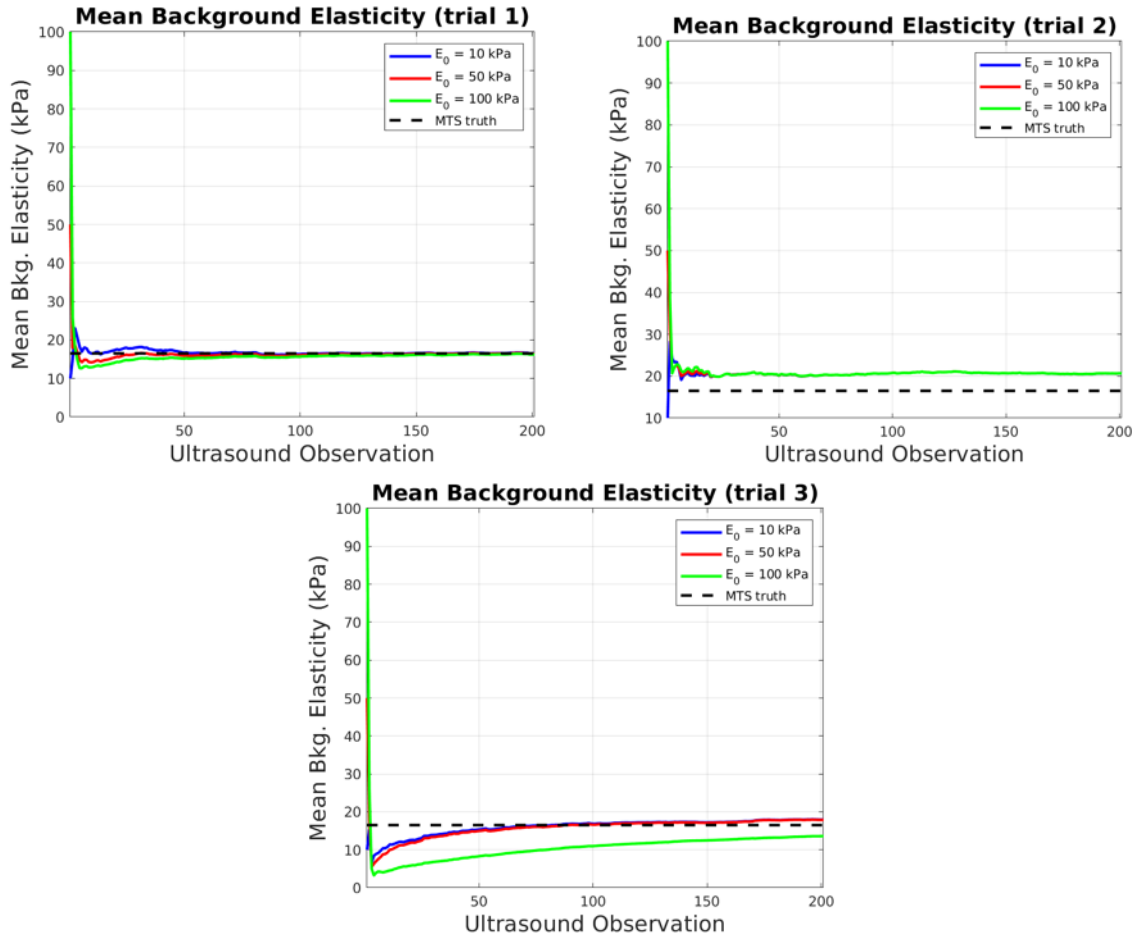

Figure 12. Convergence plots for the resulting mean background elasticities initialized at 10kPa, 50kPa, and 100kPa. Like the results in Figure 11 illustrating the performance of the algorithm for mean inclusion elasticities, regardless of the analyzed initial elasticity assumption, the algorithm converges to within 5kPa of the measured MTS values.

The convergence plots show that for all initial conditions, reasonably accurate quantitative elastograms were obtained using the proposed stochastic approach with data from the force/torque sensor, robot joint encoders, and ultrasound transducer. These trends show a promising resilience to initial conditions which carries significant practical importance as these initial estimates may not be available on patients. Additionally, to emphasize the importance of the stochastic method, the robot states were removed from the proposed method and the reconstruction was performed using joint encoder measurements only. The algorithm failed to resolve the uncertainty in force and joint encoder measurements without including the robot states which led to divergence in two out of three trials. However, the algorithm was able to recover and converge in the third trial with the resulting elastogram shown in Figure 13.

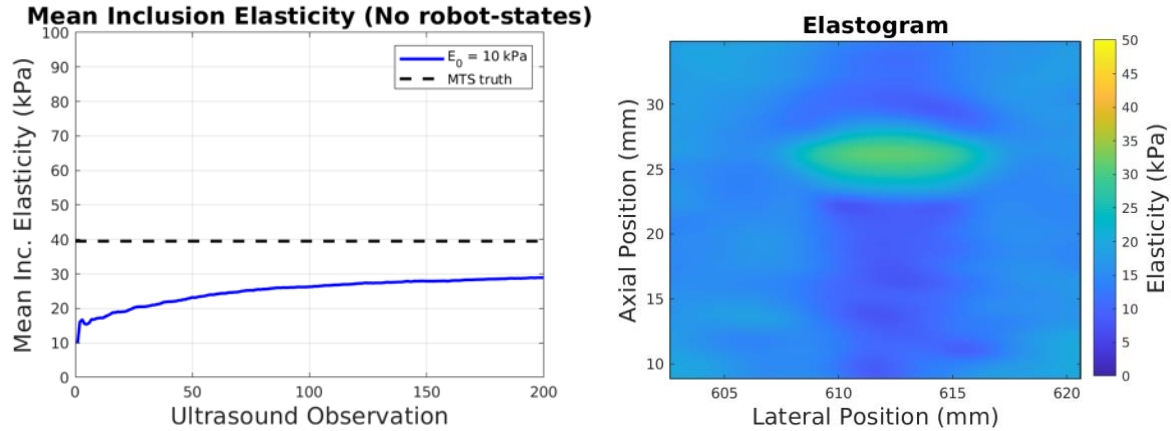

Figure 13. Convergence plot of the mean inclusion elasticity (left) for the reconstruction without incorporating the task space variables in the state vector. The resulting elastogram (right) is significantly quantitatively degraded as the stiffness of the inclusion is well below the measured MTS results.

The results in Figure 13 demonstrate the importance of including the robot state directly into the elastography reconstruction. The approach is unable to sufficiently resolve measurement uncertainty without these variables and the stability of the reconstruction is severely compromised. However, by including these variables reasonably accurate quantitative elastograms were obtained over both homogeneous and inclusion gelatin phantoms using the developed robotically assisted ultrasound scanning system explored by this research project.

Development of non-linear elastography methods proceeded in parallel with the robotic system developments. As described in our 2018 Annual Report, we developed pulse sequences for the Verasonics 64LE scanner and linear array to collect co-registered strain images and shear wave speed maps. Representative early images are shown in Figure 14. Echo signal processing to create these images was implemented in MATLAB using GPU-accelerated subroutines.

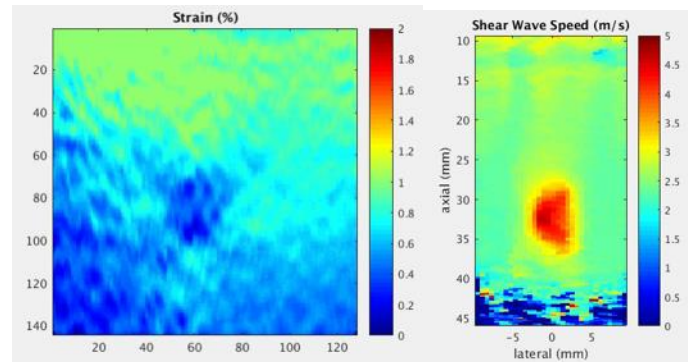

Figure 14. Strain elastogram (left) and shear wave speed image (right) of a 6.5 mm in diameter inclusion *a* in CIRS 049A phantom obtained with our system. Note the decreased strain in the inclusion, consistent with its greater stiffness relative to the background. The increased shear wave speed likewise is consistent with increased stiffness; in an elastic material, shear wave speed is proportional to the square root of shear modulus:  $G=pc^2$ .

In preparation for planned in-vivo experiments, facilities for acoustic output measurement were developed. This work included the updating of control systems of an NTR three-axis positioning system, the development of a water-treatment system including UV-sterilization, deionization, and degassing components, and software for automated mapping of acoustic fields. The system and representative acoustic field maps are shown in Figure 15.

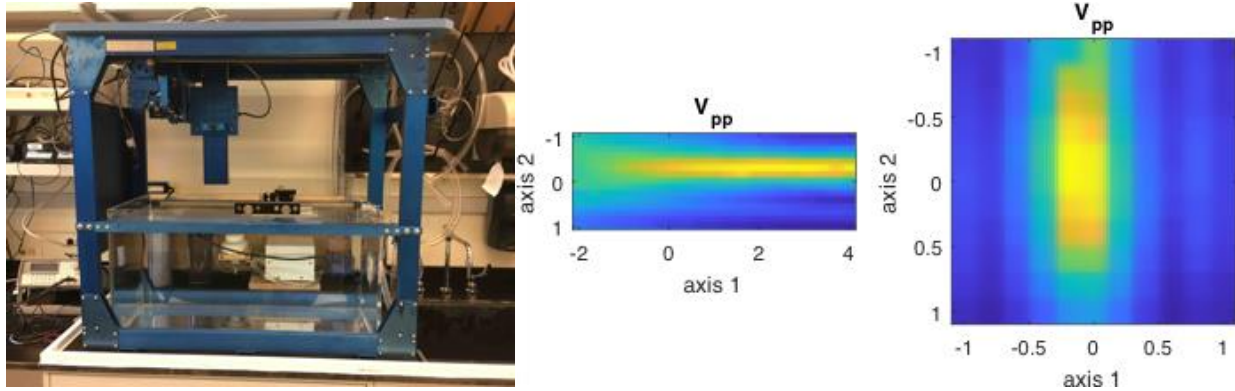

Figure 15. (left) Acoustic output measurement system, consisting of 3-axis positioner, water conditioning system, hydrophone, amplifier, and digital oscilloscope. (center and right) Representative axial (center) and transverse (right) plots of ultrasound push beam patterns obtained with the system under control of custom Matlab software.

Phantom models for evaluation of non-linear elasticity techniques were developed. Gelatin and polyvinyl alcohol (PVA) cryogel were selected as materials for these phantoms, due their easy availability and contrast in non-linear mechanical properties. Gelatin is a comparatively linear material and exhibits a small change in shear wave speed with compression. Polyvinyl alcohol cryogel exhibit significantly greater strain dependence in shear wave speed, as can be seen in the Figure 16.

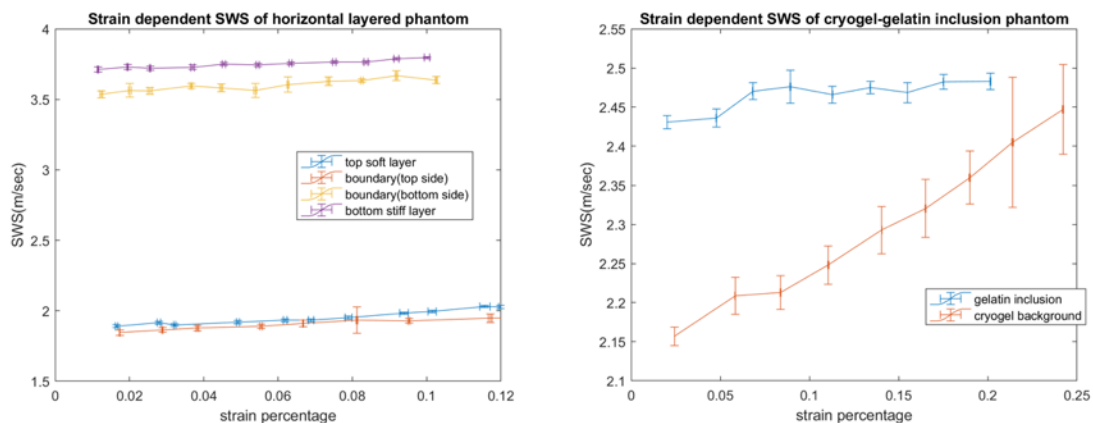

Figure 16. Left: Representative shear wave speed measurements in a phantom consisting of two layers of gelatin of differing stiffness as a function of applied strain. Shear wave speed is very weakly dependent on applied strain over a range of 0 to 12%. Right: shear wave speed measurements in a phantom consisting of a cylindrical gelatin inclusion in an PVA cryogel background. The much greater dependence of shear wave speed with strain in PVA vs gelatin is readily apparent.

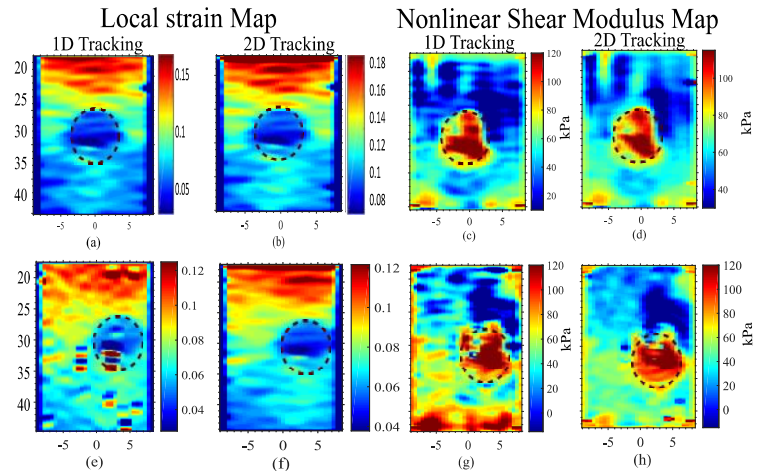
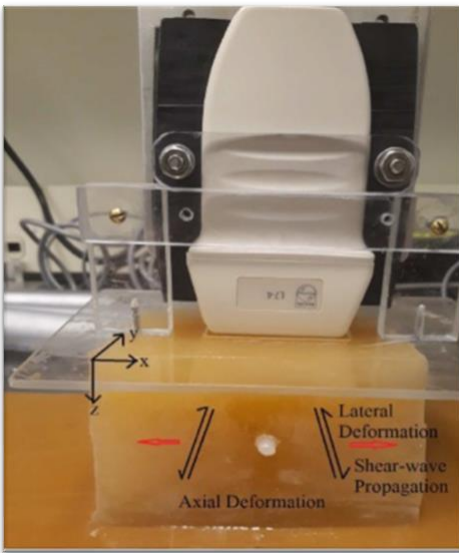

Figure 17: Left: Image of L7-4 transducer and compression paddle applied to the top surface of a gelatin phantom with cylindrical cryogel inclusion. The system we developed acquired plane wave echo data over a range of angles (-7 to 7 degrees) while incrementally increasing global strain, allowing concurrent measurement of local strain and shear wave velocity.

We implemented 2D motion tracking for estimation of strains. In this approach we use 2D speckle tracking to measure both the axial and lateral deformation of the phantom under axial (z-axis) loading. The estimation of both lateral and axial strain allows a more accurate estimate of total strain when imaging non-homogeneous media, e.g., the phantom pictured in Figure 17. The results illustrate a clear improvement in reconstructed non-linear modulus using 2D tracking. 2D tracking shows a 40% improvement in contrast, and a more than doubling of contrast-to noise ratio vs the global strain approach, and a ~40% improvement in CNR vs 1D tracking. This clear improvement in performance does not require any change in transmit beamforming and is achieved purely through improved echo post-processing.

An important development in this work was the method that models complex strain fields due to both axial and lateral motions of the imaging transducer, rather than purely axial deformations as illustrated above. This approach, termed Shear Induced Nonlinear Elasticity (SiNE) imaging, produces correct images of non-linear shear modulus, whether the applied strain is axial, lateral, or a combination of the two. The development of this method is necessary, as it is difficult or impossible when using manual manipulation of the ultrasound probe to produce pure axial or shear deformation of the breast in vivo. The SiNE method is described in Figure 18:

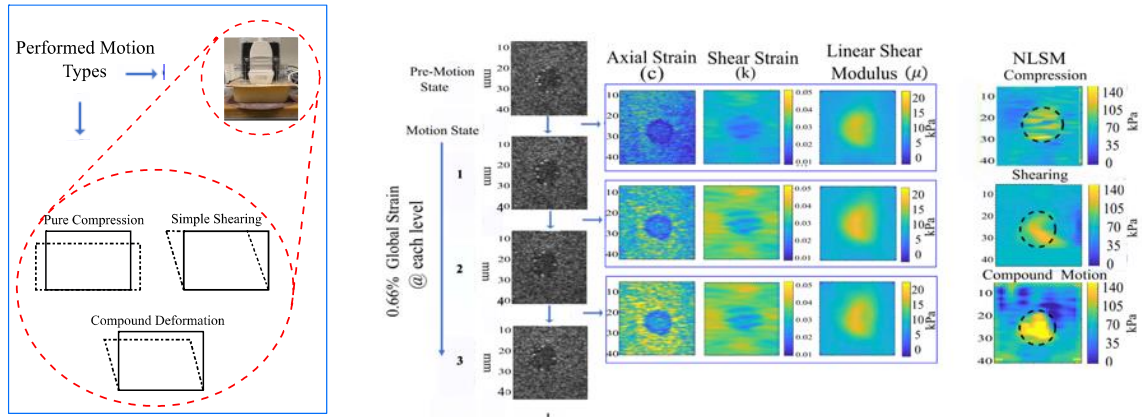

Figure 18. Left panel: Tissue deformation can be decomposed into axial and lateral components, termed “pure compression” and “simple shearing”. The change in shear wave speed as a function of strain is different for each. Center: B-mode images obtained during compound deformation of the tissue. 2D tracking of inter-frame motion provides maps of axial (c) and shear (k) strain. Shear wave elastography is used to generate matched maps of apparent linear shear modulus  $\mu$ . Right: non-linear shear modulus obtained using estimators designed for axial motion alone (top, “compression”) lateral motion alone (center, “shear”) and combined motions (bottom, “compound”). The compound estimator produces the most accurate reconstruction of the inclusion.

A key observation is that smaller shear deformation is required for the non-linear estimator to converge compared to axial deformation. As shown in Figure 19, in simple shearing the estimator converges at about half the strain level required for compressional deformation.

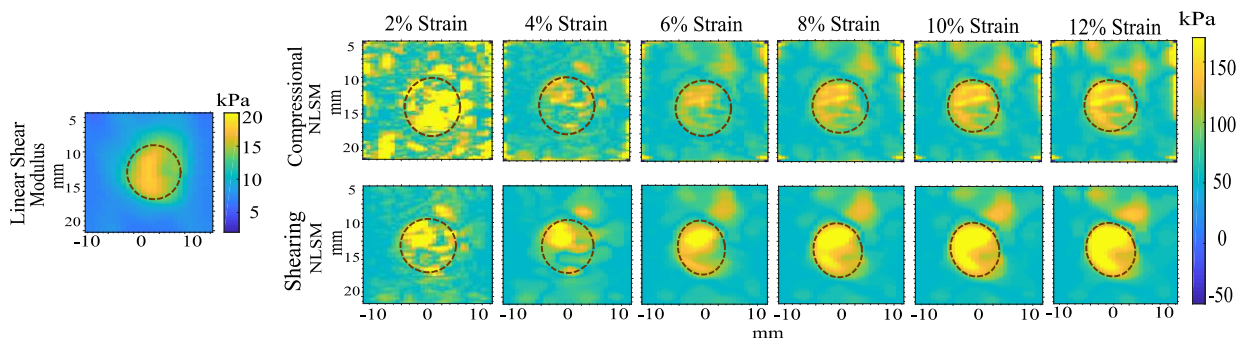

Figure 19: NLSM maps estimated in tissue-mimicking phantoms by pure compression and simple shearing for an 18 kPa inclusion in 8 kPa gelatin medium for different strain levels. The dotted circle shows the original inclusion position. Note that the NLSM map converges at ~4% strain in the shear case (bottom), while axial compression (top) requires approximately twice the strain to converge to the final estimate.

Finally, we have begun development of methods to distinguish non-linear and viscoelastic properties of tissues. The local wavenumber imaging method of Kijanka<sup>1</sup> was adapted to create images of phase velocity in soft tissue. As shown in Figure 20, spatial maps of SW phase velocity may be generated within the SW broadband excitation as a function of strain.

<sup>1</sup> P. Kijanka, and M. W. Urban, “Local phase velocity-based imaging: A new technique used for ultrasound shear wave elastography.,” *IEEE transactions on medical imaging*, vol. 38, no. 4, pp. 894-908, 2018

Frequency-dependent NLSM maps are obtained. These maps allow changes in shear wave speed due to non-linear elasticity vs viscoelasticity to be distinguished and provide an additional contrast mechanism that future work may use to distinguish tissues.

Nonlinear Elastic Inclusion - Linear Elastic Medium (Both medium & inclusion have SWS 2.16 m/sec and non-viscous)

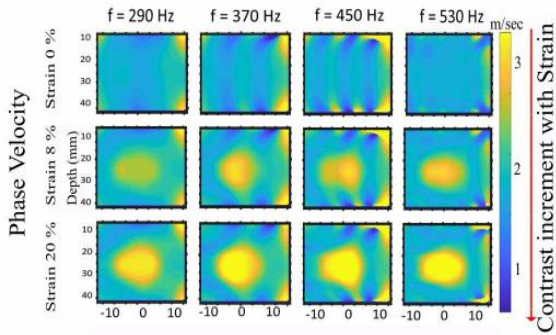

Nonlinear Viscoelastic Inclusion (1.8 Pa-sec shear viscosity)- Linear Elastic Medium (Both medium & inclusion have SWS 2.16 m/sec)

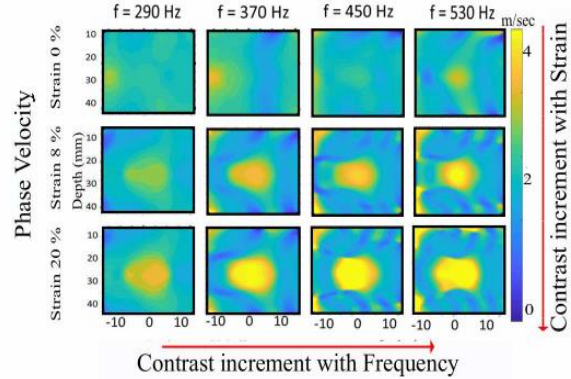

Figure 20. Simulated images of shear wave phase velocity obtained using finite-element modeling of shear wave propagation (as in figure 1) and the reconstruction method described in the text. The left panel demonstrates the results observed with a nonlinear (and non-viscous) inclusion in a linear elastic background. The observed shear wave speed increases in the inclusion, and the increase is independent of shear wave frequency. The right panel demonstrates a viscoelastic *and* nonlinear inclusion, wherein the shear wave speed increases both with frequency and global strain.

### **3.3 What opportunities for training and professional development has the project provided?**

This project has been a part of professional development for two graduate students in PI Howard's Robotics and Artificial Intelligence Laboratory. The research on hybrid force/velocity control for acquiring ultrasound scans under constant force and position setpoints supported the work of Christian Freitas as described in the 2017-2018 annual report in preparation of his master's thesis in Electrical Engineering that he defended in April 2018. The work on robotically assisted qualitative and quantitative compressional elastography is one of the principal research topics of Michael Napoli's doctoral research. Michael has proposed his PhD Thesis proposal on the topic of quantitative robotically assisted compressional elastography. Both of these individuals have published peer-reviewed research on topics supported by this grant.

This project has also supported one undergraduate and one graduate student in PI McAleavey's ultrasound imaging laboratory. Undergraduate Katelyn Offerdahl (2017-2018) worked to quantify the performance of shear wave elasticity imaging methods during periods of transducer motion. Her work led to a conference publication in the first year of this project. The work on co-registered shear strain and shear wave speed imaging is the thesis topic of graduate student Soumya Goswami. Soumya has successfully proposed his PhD thesis and is scheduled to complete his dissertation by December 2021. Both Katelyn and Soumya received one-on-one mentoring, participated in laboratory group meetings, and journal club activities.

Professional development activities for Katelyn Offerdahl include attending and presenting at the IEEE International Ultrasonics Symposium. Professional development activities for Soumya Goswami include attendance and multiple presentations the IEEE International Ultrasonics Symposiums.

### **3.4 How were the results disseminated to communities of interest?**

Results were disseminated to communities of interest through publication of refereed conference papers and research presentations at academic conferences as outlined in Section 6.1.

### **3.5 What do you plan to do during the next reporting period to accomplish these goals?**

Nothing to Report (Final Report)

## **4. Impact**

### **4.1 What was the impact on the development of the principal discipline(s) of the project?**

Nothing to report beyond the publications and presentations listed below.

#### **4.2 What was the impact on other disciplines?**

Nothing to report.

#### **4.3 What was the impact on technology transfer?**

There was no technology transfer that occurred under this project during the period of performance.

#### **4.4 What was the impact on society beyond science and technology?**

Nothing to report.

### **5. Challenges / Problems**

#### **5.1 Changes in approach and reasons for change**

Due to the impact and continued risks from COVID-19 and the suspension of in-person activities in research laboratories on the University of Rochester campus during part of this reporting period we eliminated plans to perform in-vivo or ex-vivo tissue studies involving human subjects. As outlined in our updated and approved statement of work, we focused on studies involving gelatin tissue phantoms to safely quantify the performance of the techniques developed for robotically assisted tissue stiffness estimation by maintaining social distance between researchers and eliminating contact with human subjects that would be required by our original IRB protocol. This adjustment of focus allowed us to further our research in probabilistic approaches to stiffness mapping.

#### **5.2 Actual or anticipated problems or delays and actions or plans to resolve them**

Our plan to scan human subjects was disrupted by the COVID-19 pandemic. We submitted a revised statement of work outlining a plan to replace studies involving human subjects with phantom studies; this revised statement of work was accepted.

#### **5.3 Changes that had a significant impact on expenditures**

The no-cost extension and increase in student support costs have impacted the budget with respect to graduate student support.

#### **5.4 Significant changes in use or care of human subjects, vertebrate animals, biohazards, and/or select agents**

A significant change is the (approved) plan to replace studies involving human subjects with phantom studies, due to concerns related to coronavirus.

## 6. Products

### 6.1 Publications, conference papers, and presentations

Papers, presentations, and theses created over the period of performance are listed below. Papers under review are listed separately from published papers.

#### *Publications:*

- 1) K. Offerdahl and S. McAleavey, "Influence of Transmit Beamforming Parameters on Image Quality in Quantitative Elastography," Proceedings of the 2017 IEEE International Ultrasonics Symposium, Washington, DC
- 2) M. Napoli, C. Freitas, S. Goswami, S. McAleavey, M. Doyley, and T.M. Howard, "Hybrid Force/Velocitv Control with Compliance Estimation via Strain Elastography for Robot Assisted Ultrasound Screening," In 7<sup>th</sup> IEEE International Conference on Biomedical Robotics and Biomechatronics. IEEE, Aug. 2018.
- 3) M. Napoli, S. Goswami, S. McAleavey, M. Doyley, and T.M. Howard, "Probabilistic Mapping of Tissue Elasticity for Robot-Assisted Medical Ultrasound," In International Symposium on Robotics Research, October 2019.
- 4) S. Goswami, R. Ahmed, M. Doyley, S. McAleavey, "Nonlinear Shear Modulus Estimation with Bi-axial Motion Registered Local Strain", *IEEE Transactions on Ultrasonics, Ferroelectrics, and Frequency Control* 66(8), pp. 1292-1303, May 2019
- 5) S. Goswami, S. Khan, R. Ahmed, M. M. Doyley and S. A. McAleavey, "Deformation Independent Non-linearity Estimation: Studies and Implementation in Ultrasound Shear Wave Elastography," *Proceedings of the 2019 IEEE International Ultrasonics Symposium (IUS)*, Glasgow, United Kingdom, 2019, pp. 217-220.
- 6) S. Goswami, R. Ahmed, S. Khan, M.M. Doyley, S.A. McAleavey, "Shear Induced Non-linear Elasticity Imaging: Elastography for Compound Deformations", *IEEE Transactions on Medical Imaging* 39(11) 3559-3570, 2020
- 7) S. Khan, S. Goswami, F. Feng and S. A. McAleavey, "Characterization and Evaluation of a Hydrogel-PVC Aberrator Phantom," *2020 IEEE International Ultrasonics Symposium (IUS)*, Las Vegas, NV, USA, 2020, pp. 1-3, doi: 10.1109/IUS46767.2020.9251586.
- 8) S. Goswami, R. Ahmed, M. M. Doyley and S. A. McAleavey, "Quantitative nonlinear shear modulus mapping using freehand scanning," *2020 IEEE International Ultrasonics Symposium (IUS)*, Las Vegas, NV, USA, 2020, pp. 1-3, doi: 10.1109/IUS46767.2020.9251339.
- 9) S. Goswami, R. Ahmed, M. M. Doyley and S. A. McAleavey, "Local Spectral Nonlinear Elasticity Imaging: Contrast Enhancement in Heterogeneous Elastograms based on Viscoelastic Nonlinear Characterizations," *2020 IEEE International Ultrasonics Symposium (IUS)*, Las Vegas, NV, USA, 2020, pp. 1-3, doi: 10.1109/IUS46767.2020.9251283.
- 10) F. Feng, S. Goswami, S. Khan and S. A. McAleavey, "Evaluating the Feasibility of Nondiffractive Bessel Beams for Shear Wave Elasticity Imaging: A Simulation

Study," *2020 IEEE International Ultrasonics Symposium (IUS)*, Las Vegas, NV, USA, 2020, pp. 1-4, doi: 10.1109/IUS46767.2020.9251828.

Papers Under Review:

- 1) S. Goswami, R. Ahmed, Fang Fen, Siladitya Khan, M. M. Doyley and S. A. McAleavey, Imaging the Local Nonlinear Viscoelastic Properties of Soft Tissues: Initial Validation and Expected Benefits, *IEEE Transactions on Medical Imaging*
- 2) M. E. Napoli, S. Goswami, S. A. McAleavey, M. M. Doyley, and T. M. Howard, "Enabling quantitative robot- assisted compressional elastography via probabilistic gaussian filters," *Physics in Medicine and Biology*, 2021

Theses:

- 3) C. Freitas, "Hybrid force/velocity control for semi-autonomous ultrasound scanning," Master's thesis, University of Rochester, April 2018.
- 4) M. Napoli, "A probabilistic framework that enables a novel approach to robotically assisted quantitative compressional elastography in linear elastic gelatin phantoms," PhD thesis, University of Rochester, Oct. 2021 (Proposal given May 2020, defense scheduled October 2021)
- 5) S. Goswami, "Nonlinear Shear Modulus Imaging with complex freehand tissue deformation and under the effect of tissue viscoelasticity" (Proposal given August 2021, defense scheduled February 2022)

Presentations:

- 1) K. Offerdahl and S. McAleavey, "Influence of Transmit Beamforming Parameters on Image Quality in Quantitative Elastography," presented at 2017 IEEE International Ultrasonics Symposium, Washington, DC
- 2) R. Ahmed, A. McAleavey, M. Doyley, "A Novel Tracking Strategy for Single Tracking Location Shear Wave Elasticity Imaging," presented at 2017 IEEE International Ultrasonics Symposium, Washington, DC
- 3) S. McAleavey, "Towards the Goal of High Resolution, Low Noise, and Low Variance in Shear Wave Elastography," presented at the 2017 International Congress on Ultrasonics, Honolulu, Hawaii (Invited)
- 4) M. Napoli, "Hybrid force/velocity control with compliance estimation via strain elastography for robot assisted ultrasound screening" IEEE International Conference on Biomedical Robotics and Biomechatronic 2018, Enschede, Netherlands.
- 5) M. Napoli, "Hybrid Force Velocity Control with Compliance Estimation via Strain Elastography for Robot Assisted Ultrasound Scanning", presented at the Inaugural RCBU Biomedical Ultrasound Symposium Day, Rochester, NY, USA. Nov. 2018.
- 6) S. Goswami, R. Ahmed, M. Doyley, S. McAleavey, "Nonlinear Shear Modulus Estimation with Biaxial Motion Registered Local Strain Distribution", presented at the Inaugural RCBU Biomedical Ultrasound Symposium Day, Rochester, NY, USA. Nov. 2018.
- 7) M. Napoli, "Probabilistic mapping of tissue elasticity for robot-assisted medical ultrasound", International Symposium on Robotics Research 2019, Hanoi, Vietnam

- 8) S. Goswami, R. Ahmed, M. Dooley, S. McAleavey "2D tracking improves quantitative nonlinear shear modulus estimation" Presented at the International Symposium on Ultrasonic Imaging and Tissue Characterization, Arlington, VA, June 5-7, 2019
- 9) S. Goswami, S. Khan, R. Ahmed, M. M. Dooley and S. A. McAleavey, "Deformation Independent Non-linearity Estimation: Studies and Implementation in Ultrasound Shear Wave Elastography," Presented at the 2019 IEEE International Ultrasonics Symposium (IUS), Glasgow, United Kingdom
- 10) S. Goswami, S. Khan, R. Ahmed, M. M. Dooley and S. A. McAleavey, "Deformation Independent Non-linearity Estimation" Rochester Center for Biomedical Ultrasound Symposium, Rochester, NY, Nov. 7<sup>th</sup> 2019
- 11) S. Khan, S. Goswami, F. Feng and S. A. McAleavey, "Characterization and Evaluation of a Hydrogel-PVC Aberrator Phantom," 2020 IEEE International Ultrasonics Symposium (IUS), Las Vegas, NV, USA, 2020
- 12) S. Goswami, R. Ahmed, M. M. Dooley and S. A. McAleavey, "Quantitative nonlinear shear modulus mapping using freehand scanning," 2020 IEEE International Ultrasonics Symposium (IUS), Las Vegas, NV, USA, 2020,
- 13) S. Goswami, R. Ahmed, M. M. Dooley and S. A. McAleavey, "Local Spectral Nonlinear Elasticity Imaging: Contrast Enhancement in Heterogeneous Elastograms based on Viscoelastic Nonlinear Characterizations," 2020 IEEE International Ultrasonics Symposium (IUS), Las Vegas, NV, USA, 2020
- 14) F. Feng, S. Goswami, S. Khan and S. A. McAleavey, "Evaluating the Feasibility of Nondiffractive Bessel Beams for Shear Wave Elasticity Imaging: A Simulation Study," *2020 IEEE International Ultrasonics Symposium (IUS)*, Las Vegas, NV, USA, 2020

## **6.2 Website(s) or other Internet site(s)**

There are no websites or internet sites to report.

## **6.3 Technologies or techniques**

There are no technologies or techniques to report.

## **6.4 Inventions, patent applications, and/or licenses**

There are no inventions, patent applications, and/or licenses to report.

## **6.5 Other products**

There are no other products to report.

## 7. Participants & other collaborating organizations

### 7.1 What individuals have worked on the project?

**Note: Personnel & months worked listed below reflect period since last annual report, and not the entire period of this project.**

Name:	<i>Stephen McAleavey</i>
Project Role:	<i>PI</i>
Researcher Identifier:	<i>eRA Commons User ID: smcaleavey</i>
Nearest month worked	<i>9</i>
Contribution to Project:	<i>Human subjects protocol development and approval, ultrasound shearwave elastography systems development</i>
Other Funding Support:	<i>NIH, NYSTAR</i>

Name:	<i>Thomas Howard</i>
Project Role:	<i>PI</i>
Researcher Identifier:	<i>IEEE PIN: 107736</i>
Nearest month worked	<i>7</i>
Contribution to Project:	<i>Design and development of software robotically assisted breast ultrasound scanning system, design and development of hybrid force/velocity control, simulation and haptic interface software, assisted with development of qualitative and quantitative elastography algorithms.</i>
Other Funding Support:	<i>NSF, ARL, NASA</i>

Name:	<i>Marvin Doyley</i>
Project Role:	<i>Co-PI</i>
Researcher Identifier:	<i>eRA Commons User ID: mmdoyley</i>
Nearest month worked	<i>4</i>
Contribution to Project:	<i>Strain elastography system development lead</i>
Other Funding Support:	<i>NIH</i>

Name:	<i>Christian Freitas</i>
Project Role:	<i>Graduate student</i>
Researcher Identifier:	<i>IEEE PIN: 224766</i>
Nearest month worked	<i>4</i>
Contribution to Project:	<i>Development of the hybrid force/velocity control software, Rethink Robotics Sawyer Robot interface, and Robotiq Force/Torque sensor interface for control of the manipulator in the human-robot system.</i>
Other Funding Support:	<i>NYSCoE in Data Science</i>

Name:	<i>Michael Napoli</i>
Project Role:	<i>Graduate student</i>
Researcher Identifier:	<i>IEEE PIN: 198132</i>
Nearest month worked	<i>32</i>
Contribution to Project:	<i>Development of controllers and estimators for robotically assisted breast ultrasound scanning system, experiments on hybrid force/velocity controller software capabilities for strain elastography, integration of the elastography software stack with arm control software, interfaces, and sensors, development of new qualitative and quantitative elastography algorithms.</i>
Other Funding Support:	<i>N/A</i>

Name:	<i>April Wang</i>
Project Role:	<i>Graduate student</i>
Researcher Identifier:	<i>--</i>
Nearest month worked	<i>1</i>
Contribution to Project:	<i>Ultrasound phantom fabrication</i>
Other Funding Support:	<i>NIH</i>

Name:	<i>Rifat Ahmed</i>
Project Role:	<i>Graduate student</i>
Researcher Identifier:	--
Nearest month worked	<i>1</i>
Contribution to Project:	<i>Shear wave and strain elastography sequence development</i>
Other Funding Support:	<i>NIH, NYSTAR</i>

Name:	<i>Katelyn Offerdahl</i>
Project Role:	<i>Undergraduate student</i>
Researcher Identifier:	--
Nearest month worked	<i>3</i>
Contribution to Project:	<i>Quantification of ultrasound beam sequence parameters on signal-to-noise and contrast-to-noise ratios of shear wave elastograms. Quantification of elastogram noise due to probe or tissue motion. Development of test fixtures</i>
Other Funding Support:	

Name:	<i>Soumya Goswami</i>
Project Role:	<i>Graduate student</i>
Researcher Identifier:	--
Nearest month worked	<i>27</i>
Contribution to Project:	<i>Shear wave and strain elastography sequence development, Phantom validation studies</i>
Other Funding Support:	<i>University of Rochester Department of Electrical Engineering</i>

**7.2 Has there been a change in the active other support of the PD/PI(s) or senior/key personnel since the last reporting period?**

Since the last reporting period PI Howard has a new sponsored research project with the Army Research Laboratory's Distributed and Collaborative Intelligent Systems and Technology Collaborative Research Alliance for research on language interaction with field robots titled "Abstract Meaning Representation for Grounded Language Communication with Collaborative Robots". PI Howard also was awarded a second year on his Army Research Laboratory Scalable, Adaptive, and Resilient Autonomy project titled "Efficiently Adaptive State Lattices for Robust Guidance, Navigation and Control of Unmanned Ground Vehicles" and a third year on his National Aeronautics and Space Administration Early Career Faculty Award project titled "Explainable and Verifiable Models for Human-Robot Teaming".

**7.3 What other organizations were involved as partners?**

There are no other organizations involved as partners in this research.

**8. Special reporting requirements**

There are no special reporting requirements. This report reflects the work of PI McAleavey under Award Number W81XWH-17-1-0021 and PI Howard under Award Number W81XWH-17-1-0022. Leadership and organization of research tasks have been marked with the responsible PI and site of the research activities.