

**REPORT DOCUMENTATION PAGE**

*Form Approved*  
OMB No. 0704-0188

The public reporting burden for this collection of information is estimated to average 1 hour per response, including the time for reviewing instructions, searching existing data sources, gathering and maintaining the data needed, and completing and reviewing the collection of information. Send comments regarding this burden estimate or any other aspect of this collection of information, including suggestions for reducing the burden, to the Department of Defense, Executive Service Directorate (0704-0188). Respondents should be aware that notwithstanding any other provision of law, no person shall be subject to any penalty for failing to comply with a collection of information if it does not display a currently valid OMB control number.

**PLEASE DO NOT RETURN YOUR FORM TO THE ABOVE ORGANIZATION.**

<b>1. REPORT DATE (DD-MM-YYYY)</b> 21-03-2007		<b>2. REPORT TYPE</b> Master of Military Studies Research Paper		<b>3. DATES COVERED (From - To)</b> September 2016 - April 2017	
<b>4. TITLE AND SUBTITLE</b> Women Conscripts and Building Draftee Combat Power				<b>5a. CONTRACT NUMBER</b> N/A	
				<b>5b. GRANT NUMBER</b> N/A	
				<b>5c. PROGRAM ELEMENT NUMBER</b> N/A	
				<b>5d. PROJECT NUMBER</b> N/A	
				<b>5e. TASK NUMBER</b> N/A	
				<b>5f. WORK UNIT NUMBER</b> N/A	
<b>6. AUTHOR(S)</b> Pezzat, Sarah B., Major, USMCR					
<b>7. PERFORMING ORGANIZATION NAME(S) AND ADDRESS(ES)</b> USMC Command and Staff College Marine Corps University 2076 South Street Quantico, VA 22134-5068				<b>8. PERFORMING ORGANIZATION REPORT NUMBER</b>  N/A	
<b>9. SPONSORING/MONITORING AGENCY NAME(S) AND ADDRESS(ES)</b> N/A				<b>10. SPONSOR/MONITOR'S ACRONYM(S)</b>  N/A	
				<b>11. SPONSOR/MONITOR'S REPORT NUMBER(S)</b>  N/A	
<b>12. DISTRIBUTION/AVAILABILITY STATEMENT</b> Approved for public release; distribution is unlimited.					
<b>13. SUPPLEMENTARY NOTES</b> N/A					
<b>14. ABSTRACT</b> The United States has not inducted personnel into the military since the draft induction authority expired in the mid-1970s during President Nixon's administration. The institutional knowledge of how to mobilize and utilize draftees during large-scale war-driven manpower shortages has faded. In December 2015, the restrictions against women serving in certain combat specialties were eliminated. This change in policy has driven the US Courts and Congress closer to inclusion of women in the draft. The Department of Defense faces a manpower utilization challenge in both its apparent lack of policy on how to operate a draft compounded by the likelihood of having to integrate women into the draft. This study seeks to examine the context of historical drafts, physical and physiological limitations of women, and the impact of the recent gender integration programs, and to recommend a provisional unit that accommodates manpower intricacies to maximize female draftee combat power.					
<b>15. SUBJECT TERMS</b> Draft, Gender Integration, Women, Infantry, Conscription, Draftee, Adaptation, Constabulary Battalion					
<b>16. SECURITY CLASSIFICATION OF:</b>			<b>17. LIMITATION OF ABSTRACT</b>  UU	<b>18. NUMBER OF PAGES</b>  69	<b>19a. NAME OF RESPONSIBLE PERSON</b> USMC Command & Staff College
<b>a. REPORT</b>  Unclass	<b>b. ABSTRACT</b>  Unclass	<b>c. THIS PAGE</b>  Unclass			<b>19b. TELEPHONE NUMBER (Include area code)</b> (703) 784-3330 (Admin Office)

*United States Marine Corps  
Command and Staff College  
Marine Corps University  
2076 South Street  
Marine Corps Combat Development Command  
Quantico, Virginia 22134-5068*

MASTER OF MILITARY STUDIES

---

---

**TITLE:**

Women Conscripts and Building Draftee Combat Power

SUBMITTED IN PARTIAL FULFILLMENT  
OF THE REQUIREMENTS FOR THE DEGREE OF  
MASTER OF MILITARY STUDIES

**AUTHOR:**

Major Sarah B. Pezzat  
United States Marine Corps Reserve

AY 16-17

---

---

Mentor and Oral Defense Committee Member: \_\_\_\_\_

Approved: \_\_\_\_\_

Date: \_\_\_\_\_

Oral Defense Committee Member: \_\_\_\_\_

Approved: \_\_\_\_\_

Date: \_\_\_\_\_

## Executive Summary

**Title:** Women Conscripts and Building Draftee Combat Power

**Author:** Major Sarah B. Pezzat, United States Marine Corps Reserve

**Thesis:** For a large-scale mobilization in support of a major military campaign, female draftees deemed fit for unrestricted military service should be used to construct constabulary infantry battalions.

**Discussion:** The United States has not inducted personnel into the military since the draft induction authority expired in the mid-1970s during President Nixon's administration. The institutional knowledge of how to mobilize and utilize draftees during large-scale war-driven manpower shortages has faded. In December 2015, the restrictions against women serving in certain combat specialties were eliminated. This change in policy has driven the US Courts and Congress closer to inclusion of women in the draft. The Department of Defense faces a manpower utilization challenge in both its apparent lack of policy on how to operate a draft compounded by the likelihood of having to integrate women into the draft. This study seeks to examine the context of historical drafts, physical and physiological limitations of women, and the impact of the recent gender integration programs, and to recommend a provisional unit that accommodates manpower intricacies to maximize female draftee combat power.

**Conclusion:** There are substantial complexities involved in generating provisional constabulary infantry battalions. However, if a constabulary infantry battalion consisting of female draftees can be employed in a manner that provides solvency, then manpower difficulties of a draft can be mitigated.

*Table of Contents*

	Page
DISCLAIMER . . . . .	i
LIST OF ILLUSTRATIONS . . . . .	ii
LIST OF TABLES . . . . .	iii
PREFACE . . . . .	iv
INTRODUCTION . . . . .	1
BACKGROUND . . . . .	2
Legal Discussion . . . . .	3
The All Volunteer Force . . . . .	4
Historical Perspective . . . . .	5
Population Analysis . . . . .	8
IMPEDIMENTS TO SIMPLE INTEGRATION . . . . .	8
Job Performance Predictors . . . . .	9
Physical Considerations . . . . .	9
Physiological Impediments . . . . .	12
Negligible Factors . . . . .	14
Conclusion . . . . .	15
INTEGRATION PLAN CONSIDERATIONS . . . . .	15
Pre-Induction Testing . . . . .	16
US Army . . . . .	18
US Marine Corps . . . . .	19
Proposed Assignment Criteria . . . . .	21
CASE STUDY: ISRAEL DEFENSE FORCES. . . . .	22
CONSTABULARY INFANTRY BATTALION . . . . .	25
Definitions . . . . .	27
Missions . . . . .	28
Task Organization . . . . .	30
Aggregation and Piecemealing . . . . .	31
Equipment . . . . .	32
Challenges . . . . .	32
CONCLUSION . . . . .	34

*Table of Contents (continued)*

	Page
APPENDIX A: MISSIONS AND ADAPTATIONS . . . . .	A-1
APPENDIX B: TASK ORGANIZATION . . . . .	B-1
GLOSSARY . . . . .	I-I
BIBLIOGRAPHY . . . . .	II-I

## DISCLAIMER

THE OPINIONS AND CONCLUSIONS EXPRESSED HEREIN ARE THOSE OF THE INDIVIDUAL STUDENT AUTHOR AND DO NOT NECESSARILY REPRESENT THE VIEWS OF EITHER THE MARINE CORPS COMMAND AND STAFF COLLEGE OR ANY OTHER GOVERNMENTAL AGENCY. REFERENCES TO THIS STUDY SHOULD INCLUDE THE FOREGOING STATEMENT.

QUOTATION FROM, ABSTRACTION FROM, OR REPRODUCTION OF ALL OR ANY PART OF THIS DOCUMENT IS PERMITTED PROVIDED PROPER ACKNOWLEDGEMENT IS MADE.

*Illustrations*

	Page
Figure 1. Weight Lift Capability of Male and Female Air Force Basic Trainees . . . . .	11

*Tables*

	Page
Table 1. Minimum Pre-Induction Physical Assessments, Minimum Passing Scores . . . . .	17
Table 2. OPAT Scoring Chart . . . . .	19
Table 3. Marine Corps Combat Arms Physical Standards. . . . .	20
Table 4. Marine Corps Load Bearing Unit Assignment Criteria. . . . .	21

## *Preface*

As a female Marine, I have often heard numerous reasons from my male counterparts as to why females would not be successful in combat arms. As a logistics officer with more time in Headquarters Marine Corps than the fleet, I often defer to their expertise. But I felt it would be remiss if I did not take this research opportunity to more thoroughly study women in combat. The matter of female integration into combat arms is not an issue for the history books quite yet. Integration plans are still being implemented into the military services as of the date of this research. As I decided on my research topic, I felt that I might be able to provide military leaders a bit more than personal anecdotes on female physical ability upon which to base their support of the mandated integration of women into combat arms.

In this essay, I sought to review a mostly untouched ramification of the female integration programs: the induction of women into the military through the draft. The military service-integration programs utilize physical capability filters to ensure only the most physically capable service members attain combat military-occupational specialties. But these filters may have negative consequences in terms of manpower application during a draft, when manpower in combat arms is needed most. In examining how best to use female draftees, it brought to the forefront the idea that women warriors can be used in roles other than administration and logistics.

To use all draftee manpower in the most advantageous way, however, requires some change to the combat arms institution. Changes to that institution typically are railed against as social manipulations and civilian interference at the cost of combat effectiveness. The same tropes have been declared by critics of racial integration and at the elimination of the ban on gays in the military – with absence of its actual occurrence. This research seeks to get beyond the

emotional repudiations of gender integration to show that – as the Israel Defense Forces have found – there is combat power to be gleaned from women warriors if we are willing to make some valuable adjustments to our institutions.

Finally, I would like to thank Christi Bayha, Marine Corps University research librarian, for her extensive assistance with researching a number of items to include policy that apparently is non-existent and my Master of Military Studies Mentor, Dr. Christopher Stowe, War Studies Department Head for his guidance throughout this process.

## **Introduction**

On December 3, 2015, then-Secretary of Defense Ash Carter announced that the Department of Defense would open all military occupations previously closed to women with no exceptions. The current Secretary of Defense, retired US Marine Corps General James Mattis, has previously questioned the suitability of women for combat.<sup>1</sup> Regardless of the new administration's opposition to women in combat, the likelihood of closing any military occupational specialties a year and a half after the Department of Defense opened them seems remote. Since Secretary Carter's announcement, each military service culminated its implementation research efforts and produced implementation plans to filter women into previously closed combat arms specialties. Included in these service plans are thresholds and limitations to ensure personnel without the requisite physical capability would not be permitted to enter into these combat arms specialties. This is ostensibly to preserve combat effectiveness of combat arms units.

A conventional war against a traditional nation-state near-peer adversary is not the future operating environment as described by Joint Chiefs of Staff force-development analysts.<sup>2</sup> The United States does, however, prudently maintain the personnel and equipment for and train toward the possibility of a conventional war. As a possible eventuality, it would be similarly prudent to explore how to maximize the utilization of females in a combat role, in the event of a large-scale mobilization of American manpower by a draft not limited to males. The Department of Defense would likely render the preponderance of female conscripts ineligible for combat roles if it applied service integration plan restrictions alone. During massive campaign preparation, akin to that of World War II, a draft is for the purpose of wholesale combat-unit

construction. By reducing manpower available to constitute combat units, the military would then need to expand the draft, resulting in unnecessarily large non-combat military populations.

This Master of Military Studies essay seeks to determine the appropriate mix of gender constraint-related adaptations and limitations applied against a general-purpose infantry unit in order to reverse engineer a serviceable combat-unit framework. To do so, this essay will examine female impediments to combat roles, potential assignment criteria, and the exemplar Israeli Defense Force mixed-gender infantry battalions in order to furnish a notional battalion based upon a menu of possible tasks that accommodate existing combat role impediments. For a large-scale mobilization in support of a major military campaign, female draftees deemed fit for unrestricted military service should be used to construct constabulary infantry battalions.

## **Background**

To understand the enormity of the task of inclusion of a separate female population with unique characteristics, largely untapped by the military, into a mass-conscription scenario, the American draft system must be dissected. The last draft call occurred in December, 1972, in support of operations in Vietnam. The institutional knowledge, not of registration or induction, but rather draftee utilization plans by the military has eroded over the last 45 years. It would appear that there is no existing Department of Defense or military service-level policy or doctrine germane to draft manpower employment. Additionally, there is no present legal authority in which to induct personnel into the military via the Military Selective Service Act. While the constitutional law precedent regarding the draft of women currently supports exclusion, the last ruling is simply awaiting a current challenge under the equal protection clause, in light of the 2015 lift of the combat ban. Assuming the actualization of legal authority to draft,

resumption of draft inductions, and successful legal challenges to inclusion of women in the draft, today's population can be compared to the statistics of historical draft paradigms to determine a baseline manpower pool. The manpower pool will help to inform the magnitude of the task of maximizing utilization of female manpower in a combat role.

### Legal Discussion

Since women currently have no gender-based restrictions from being assigned to combat units or specialties, lawmakers in Congress began discussions on whether the Military Selective Service Act should be changed to allow for the registration of women.<sup>3</sup> The Selective Service System registration, currently a requirement only for citizens and resident males from ages 18 through 25, has previously withstood legal challenges under the Equal Protection Clause of the Fifth Amendment of the US Constitution. In the *Rostker v. Goldberg* decision, the US Supreme Court upheld the Military Selective Service Act as constitutional and found that it did not violate equal protection due to the existing combat exclusion regulations precluding women serving in combat roles.<sup>4</sup>

In 2013, James Lesmeister and the National Coalition for Men, a men's rights organization, filed a lawsuit against the Selective Service System stating that the male-only draft registration constituted sex discrimination under the Fifth and Fourteenth Amendments.<sup>5</sup> This lawsuit was filed after then-Secretary of Defense Leon Panetta had announced the removal of the ban on women in combat roles. It was dismissed by the US Central District Court in California ruling that the suit was "unripe" because the military was still working to integrate women over a multi-year plan into previously closed roles.<sup>6</sup>

In February 2016, the 9th Circuit Court of Appeals reversed the dismissal of the suit on the grounds of ripeness.<sup>7</sup> Consequently, the merit of the challenge to the Selective Service

registration has yet to be decided in the courts. Regardless of the District Court ruling, the case may very well languish in the court system for years unless Congress decides that it will expand registration to women as well. In November 2016, it declined to do so by stripping female draft registration language from the National Defense Authorization Act.<sup>8</sup>

### The All-Volunteer Force

The principle reason why the draft is not currently instituted as it has been in past US history is due to the deliberate expiration of draft-induction authority and the ushering in of the all-volunteer force (AVF) military. The induction authority of the Military Selective Service Act expired in 1973 at the behest of President Richard Nixon, resulting in an all-volunteer force.<sup>9</sup> The AVF came at the conclusion of a combination of failed Selective Service reform and several analytic studies that determined that the draft was no longer viable.<sup>10</sup>

During the transition from the draft, concerns over women's ability to adapt to military service were reflected in the analysis of the AVF. Among those concerns highlighted by the Army's Directorate of Personnel Studies and Research report of 1969 were rates of sexual assault, high cost of separate habitation and sanitation facilities, women's ability to live in austere conditions, and female physical capacity.<sup>11</sup> In particular, the Army believed that no woman would be able to "perform under the conditions experienced by maneuver elements in tactical operations" and advised against women at combat arms units below the corps level.<sup>12</sup> The Army's Women in the Army Policy Review report of November 1982 determined that, based upon military occupational specialty, physical demands and the combat exclusion policy of the time, many specialties would be restricted to only men.

The Jimmy Carter administration also attempted to push for inclusion of the registration of women for a possible draft.<sup>13</sup> This was resisted in Congress as well as within the military,

with legislators citing women's lack of emotional and physical fitness for military service.<sup>14</sup> At the time, military members felt resentment at female members' inclusion into increasingly larger areas of the force and felt as if the inclusion policies were being made for "political expediency and misguided desires for social equity" at the expense of combat readiness.<sup>15</sup> The legacy of questioning a female military member's military capacity – especially in combat – persists today despite the fall of the combat-exclusion policy and military occupational specialty restrictions.

### Historical Perspective

With the apparent absence of Department of Defense policy on the utilization of draftees, historical examples provide sample methodologies for understanding how the draft has been previously employed. This essay will explore two historical examples that are different in approach in addition to timeframe: Vietnam, the most recent instance of a draft; as well as World War II, a draft of remarkable proportions, both provide unique cases of draftee utilization.

#### *Vietnam*

The draft during the Vietnam War did not reflect the massive forward mobilization of unit-sized draftee elements in preparation of theater operations such as those accomplished during World War II. Approximately 21% of the entire US military force during the Vietnam War consisted of draftees compared to 63% during World War II.<sup>16</sup> During the Vietnam era, the type of draft was one in which inducted personnel were predominantly used as casualty replacements based on demand signal.

The methodology in which Vietnam draftees were inducted and utilized demonstrated a combat-casualty demand-signal paradigm. During the Vietnam War from 1964 through 1975, approximately 8.74 million military members served. Of those, only 30%, or 2.59 million, were deployed to South Vietnam. The total number of casualties in theater represented approximately

1/8th of the deployed force with 58,200 deaths and an additional 153,303 wounded.<sup>17</sup> These casualties were also primarily combat forces that then had to be replaced with corresponding combat specialties throughout this conflict.<sup>18</sup> By 1969, approximately 88% of the Army riflemen in Vietnam and the majority of combat deaths were draftees.<sup>19</sup> As the mobilization numbers were capped, military manpower that has been raised for Vietnam operations had to be applied directly to casualty replacement. This demonstrates that demand signal of casualty rates primarily dictated draftee throughput.

### *World War II*

World War II mobilization, on the other hand, was based upon the United States preparing for the eventuality of joining a large-scale multi-nation-state and multi-theater war. As compared to the Vietnam War, which seemed a side-effort to the overall Cold War, World War II was the entire focus of not just the American military but of the United States writ large. During World War II, the United States conducted industrial mobilization in which private factories shifted production in support of the war effort. The United States conducted rationing of goods in order to control supply and demand and reduce the effect on the American populace during shortages as a result of import restrictions.<sup>20</sup> While not all Americans were united during World War II, such as grieving widows of dead soldiers and interned Japanese Americans, the US government was largely able to engender the public's patriotic commitment to the war effort.<sup>21</sup>

The massive and graduated mobilization of manpower through the draft in advance of a possibly multi-theater war against multiple nation-states demonstrates a high-volume draft paradigm. Distinct from Vietnam's paradigm, World War II conscripts were not a stream of combat replacements, though they did replace combat losses. They were planned for in advance

of large-scale operations to constitute whole units and fully fleshed detachments. Though the increase in mobilization was gradual, it was only modulated due to lagging organizational equipment production, delays in Congressional appropriations, and flagging volunteer numbers.<sup>22</sup> Unlike Vietnam's model, the end state of mobilization force strength was high. At the height of World War II, the number serving in the military was over 12 million compared to the 3.2 mil deployed to Southeast Asia over the course of a nine-year period in support of the Vietnam War.<sup>23</sup>

#### *Application to Gender-Neutral Draft*

Reserve component manpower can largely be utilized for combat replacements in a manpower demand-signaling style of draft, similar to the one during the Vietnam War. Attitudes regarding the use of reserves in operations have changed since Vietnam. As evidenced by the large call up of reserves during the Global War on Terror, the reserve component is no longer seen as a tertiary measure behind regular forces and conscripts.<sup>24</sup> This renders the requirement for draftees only necessary only in a case in which moderate casualty rates are sustained over a significant length of time. This would have a cumulative effect that would outpace the Department of Defense's ability to generate manpower from the reserves. Female integration policies could then be applied to incoming female draftees in order to determine whether they meet the thresholds to become combat arms specialists.

In the event of a draft in support of a large-scale campaign in which there is requirement to reconstitute or construct combat units, the high-volume draft of World War II would likely be applicable. This essay seeks to analyze how best to apply women, in large numbers, to generate the combat power requisite of the draft mobilization. One half of the mobilized manpower cannot just be placed into combat service support and administrative roles as it both violates the

Equal Protection Clause and runs counter to the Secretary of Defense order to open all combat roles to women without exception.

### Population Analysis

Today's eligible population is approximately 35.7 million, based on the ages of 18 to not-yet 26 years old specified in the Selective Service Act.<sup>25</sup> The number of potential inductees minus approximated deferments, exemptions, and disqualifications would leave approximately 15.2 million. Of these, approximately 6-7 million would be women. This is simply too large a population to shuttle into combat service support specialties such as administration and supply. Only 27% of fiscal year 2015 enlisted force of the active-duty Army was assigned to force sustainment.<sup>26</sup> While the overall numbers of personnel would rise during a draft to include force support, the assignment of 50% of raised manpower to force support is not necessary. Further, as draft calls increase to meet combat unit staffing goals, the number of excess force support personnel would rise dramatically. Therefore, a solution in which female draftees are utilized to maximize combat power, as opposed to excess force support, must be devised.

### **Impediments to Simple Integration**

Military effectiveness has long been espoused as the primary discriminator in restricting women's inclusion into combat roles. As studied by the Brookings Institution in 1977, factors such as leadership, discipline, training, and group relationships muddle the analytical ability to measure effectiveness.<sup>27</sup> An inability to determine the measureable differences between men's and women's military effectiveness led the Brookings Institution to determine that the arguments both for and against women in combat are mostly ideological.<sup>28</sup> This is not to preclude the idea that there are gendered differences in physical capacity or physiology. Simply, there have been

no actual causal ties made between women's service capacity and actual quantitative reduction in military effectiveness of a completely combined force.

### Job Performance Predictors

Ability to perform in any job – not just a combat role – is contingent on aspects beyond physicality such as mental ability, education level, and job aptitude. In analyzing how the military evaluated mental quality of women versus men, the Brookings Institution found that there was disparity in how women and men were determined to be qualified. In the early to mid-1970s, it determined that women on average were much more highly educated.<sup>29</sup> However, it could come to no further conclusion as to the differences between mental ability and job aptitude due to a likely inherent sex bias in military measurements and a questionable relationship between aptitude test scores and actual job aptitude.<sup>30</sup>

In 1990, Dr. Janet Shibley Hyde published a study demonstrating no overall differences between young males and females in math ability.<sup>31</sup> Hyde also found a slight but negligible verbal ability advantage of females over males. In 2005, Hyde studied differences between the sexes in cognition, communication style, social and personality variables, motor behaviors, and moral reasoning. Among this battery she found small or negligible differences.<sup>32</sup> The conclusion researchers drew was that the large disparity of men over women in math and science fields was due to cultural and societal factors, not aptitude.<sup>33</sup> Of the job aptitude research transcending cultural and societal bias, researchers found women were better prepared than men for any job, both educationally and verbally.

### Physical Considerations

Military policy regarding physical standards for decades prior to the AVF dictated that if a recruit were capable of meeting the minimum medical requirements, he would be capable of

being trained to a requisite physical capacity.<sup>34</sup> The 1977 study by the Brookings Institution found that there was no strong tie between job specifications and physical qualifications.<sup>35</sup> It projected that a small number of men, likely of diminutive stature, were physically unqualified for combat yet had still been assigned to combat jobs. Those men would need to be assisted by their larger colleagues in activities that were physically demanding or assigned to low-strain positions within combat arms units.<sup>36</sup> This theory reasoned that as long as the number of physically constrained personnel in combat jobs remained low, purportedly sustained by the restriction of women from those jobs, there would be no problem with the oversight.<sup>37</sup> This theory, assuming its validity, becomes problematic with the assignment of a large number of women to the combat arms force.

In a pioneering experiment, the Air Force in the 1970s instituted an additional standard to the traditional battery of medical tests, known as Factor X, to discern a recruit's success in physically demanding jobs.<sup>38</sup> Factor X was an addition to the traditional medical profile that specifically measured a recruit's ability to lift three ranges of weights to a certain height. The test was found to have successful predictive value in determining assignment to physically demanding positions.<sup>39</sup> In 1983, the Air Force modified its study using the Incremental Weight Lift Test, which added weight hold endurance testing. Researchers found that during the most strenuous portion of these tests, the average female recruit had only half the weight lift and hold capacity of the average male recruit as demonstrated in Figure 1.<sup>40</sup> Additionally, a portion of both men and women tested showed comparable weight lift capacity shown as an overlapping curve in Figure 1.

Figure 1: Weight Lift Capability of Male and Female Air Force Basic Trainees

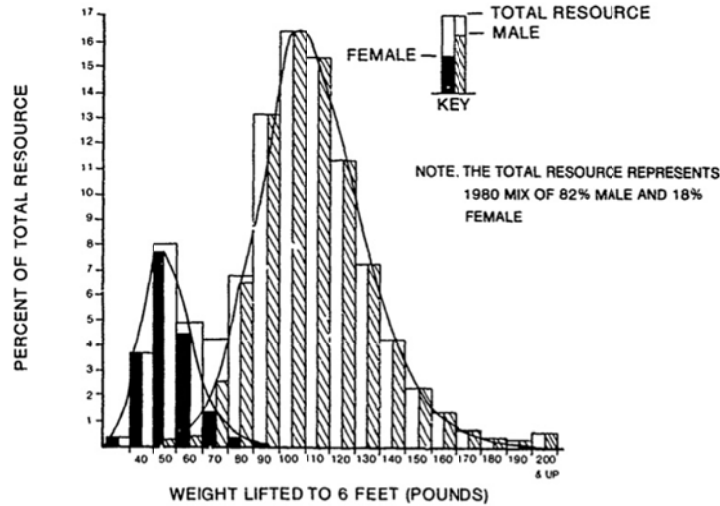

*Source:* Weight Lift Capabilities of Air Force Basic Trainees, Air Force Aerospace Medical Research Laboratory, May 1983.

The Air Force study studied prior physical tests of the ability of female subjects to overcome disparities in physical capacity through training. After training 73 subjects over a 10-week period, analysts determined that while women can markedly increase their physical capacity, they are unable to overcome the difference in upper-body strength between men and women through training.<sup>41</sup> After a review of several similar tests, Air Force researchers concluded that while training could not eliminate a physical gap between all men and women, physical training, in as little as two weeks, could leverage a significant portion of female population into eligible range for physically demanding duty.<sup>42</sup>

The Special Operations Command (SOCOM) integration study provided the most candid examination of gendered physical differences. The study stated that based upon multiple physical meta-analyses, on average men score higher than women in the areas of muscular strength and cardiovascular endurance.<sup>43</sup> Men and women rated about the same in flexibility and balance.<sup>44</sup> However, it also found that those ratings were composite ratings. The more the research drilled down into specific body-strength areas, the more meaningful the understanding

of sex-based physical differences. For instance, in studies focused on core-muscle strength, there was little difference between men and women, but in terms of coordination, men showed a slight edge over women.<sup>45</sup>

Another underlying factor brought out by the SOCOM study was the observed difference in capacity of men and women of the general population versus men and women who pass a baseline requirement of a physical test. SOCOM proposed that the disparity between sexes would be reduced by the institution of physical baseline requirements in order to ferret out higher physical performers.<sup>46</sup> Finally, the SOCOM study also concluded that while training can increase female physical capacity, it does not eliminate the physical gap between the sexes.<sup>47</sup>

This series of studies suggests that a baseline physical test and physical training, in addition to the existing Department of Defense-mandated medical and military service-recruit physical tests, should be instituted to incoming draftees. Baseline physical tests should be focused on measuring lift and holding capacity of both upper- and lower-body strength, modeled after the Air Force's Incremental Weight Lift Test, as well as cardiovascular stamina. Draftees achieving scores at least 10% below the baseline threshold should be offered the opportunity to participate in a physical training regimen for three weeks before they were retested. While this *prima facie* policy for draftees would be neutral with respect to sex, based upon the results of physical testing, it would have the largest positive impact on draftee manpower management and most-capable female draftee combat arms throughput.

### Physiological Impediments

Many female physical-capacity disparities can primarily be linked with the average female physiology, which is typically smaller and less muscular than the average male physiological profile. As summarized by the SOCOM integration study, on average women are

approximately 5 inches shorter, have 40% less upper and 33% lower muscle mass, have 6-14% more body fat, have shorter limbs relative to body length, and have a wider pelvis than men.<sup>48</sup> This translates to 25-35% less maximal oxygen uptake, less muscular strength, less absolute anaerobic power, a lower center of gravity, and an increased risk of overuse injuries.<sup>49</sup> Women do have the advantage over men in terms of resistance to muscle fatigue relative to body mass and quicker recovery.<sup>50</sup>

SOCOM concluded that adaptation to accommodate the average female's smaller physiology as well as a focus on cardiovascular endurance training can minimize the physiological disparities between the sexes. The 1983 Air Force study concluded that while the physiological differences were not of predictive value for assignment, they could be used to determine criteria for organizational equipment such as personal protective equipment.<sup>51</sup> The Marine Corps Force Integration Office (MCFIO) also studied physiological differences between the sexes in which it assessed its ability to adapt equipment to reduce physiological limitations of females. The study concluded that approximately 53% of female Marines are not in optimally sized equipment based upon their height.<sup>52</sup> This results in a degradation of mobility due to improperly fitting vests.

Adaptability solutions of some female physiological limitations should be applied whenever they can be. To combat improperly fitted equipment, for a gender-neutral draft, the Department of Defense will need to budget for purchase of additional smaller-sized body armor. In advance of that, force innovators should begin the arduous process of development and acquisition of smaller and lighter protective clothing, thinner and lighter armor plates, and female-ergonomic pack frames. Not only would it benefit the entire force in the long run, it will become essential as female draftees arrive in large numbers. For female physiological difference

areas such as less muscle mass and more body fat, adaptation of equipment cannot provide a solution. The best solution will be to restrict how far and fast the female draftee must go and to limit the individual's carry load that cannot be transported on vehicle lift. This will have significant implications on how the female draftee can be utilized and it would lend itself to those with such restrictions being placed into units together.

### Negligible Factors

Opponents of females in combat have raised issues such as violence squeamishness, pregnancy, menstruation, and field hygiene. In the SOCOM integration study, researchers studied psychological stress management between the sexes. This study admitted that while it appeared that men appear to have larger stress responses than women depending on the context, it also relayed that the female stressors studied were environmental, such as sexual and gender harassment, as compared to male stressors, such as combat.<sup>53</sup> The study concludes that stress studies appear to be much more contingent on other factors such as personality, which have a "much larger impact than sex and gender on responses to stress."<sup>54</sup> This would indicate that aversion to violence is not actually predicated by gender but rather appears to be contingent on other factors such as environment stressors and individual personality.

The Brookings Institution study of 1977 concluded that women's fertility had been a cultural rationale to keep women out of the workforce.<sup>55</sup> While pregnancy could occur while a female is deployed into a combat zone, there is no reason to believe it would occur at higher incidence than a female deployed in a combat-support role versus a combat role. Pregnancy is a temporary medical condition that can be managed by basic medical detachment as the patient is processed out of theater.

Feminine hygiene and menstruation can be easily managed in a manner that prevents it from interfering with mission success, even in a field or deployed environment. Menstruation in combination with arduous exercise can result in iron deficiency anemia.<sup>56</sup> As anemia can degrade physical performance, unit-level medical personnel should issue female personnel an iron supplement as a preventative measure. Unit logistics should be prepared to order Class VI, personal demand items, specifically Type II Health and Comfort Packs, which can provide a 30-day supply of feminine hygiene items for up to 10 women. Women can also be provisioned the same hygiene wipes available to male personnel found in Type III Health and Comfort Packs for cleanliness in austere environments. Commanders should ensure they are familiar with these items and that they are made readily available to their personnel.

### Conclusion

Female draftees will differ in physical capacity and physiology from their male draftee counterparts. In order to maximize usage of female draftees to build combat power, physical training can help increase physical capacity and reduce the disparity between the average female and average male in physical tasks. By utilizing a baseline assessment test, the military can cull the least physically capable from the pack and assign the rest to combat units. Where adaptability cannot overcome physical disparity and physiological differences, assignment of female draftees with like capabilities can be assigned to constabulary infantry battalions.

### **Integration Plan Considerations**

In order to determine the impact of integrating women into combat arms units and specialties, each of the services conducted studies on gender differences. These studies highlight physical and physiological differences between the average male and female populations with

women being at a marked disadvantage in particular areas such as upper-body strength and smaller statures. In creating implementation plans in anticipation of the Department of Defense removal of barriers to women serving as combat arms personnel, each service examined areas that could be accommodated and other areas that would need restrictions. The developed implementation plans of the services assist in understanding gendered differences but also serve to place limitations in assignment criteria hampering potential draftee utilization. Each military service developed its own plan that has different restrictions and assessments distinct from other services.

This essay focuses on the Army and Marine Corps as the most likely recipients of draftees in a major land war. The integration plans do not provide information regarding physical assessment modifications for the large numbers of personnel needed in combat arms during a draft. Additionally, this assessment difference highlights the number of tests that a draftee could potentially be required to take. Each military service has different military occupational specialty (MOS) requirements and unique assessment tests. Therefore, the service integration plans compound complexity in manpower allocation during high-volume drafts.

#### Pre-Induction Testing

Recruits must meet a physical-assessment test minimum standard in order to enter active duty to begin initial entry training. All military services administer slightly different tests and have gendered scoring as demonstrated in Table 1. In the Army, the 1-1-1 Physical Fitness Assessment is given to enlisted recruits who must pass the test prior to reporting to initial entry training.<sup>57</sup> Prospective Army officer candidate pre-contract requirements vary by source of entry. However, each candidate must pass the Army Physical Fitness Test (APFT) with a minimum of 60 points in each physical category in order to receive his or her commission.<sup>58</sup>

Table 1: Minimum Pre-Induction Physical Assessments, Minimum Passing Scores

Type	Event	Male	Female
<b>Enlisted</b> US Army 1-1-1 Physical Fitness Assessment	1 min of push-ups	13	3
	1 min of sit-ups	17	17
	1 mile run	8:30	10:30
<b>Enlisted</b> US Marine Corps Initial Strength Test	Pull-ups or push-ups	3 or 34	1 or 15
	2 min crunches	44	44
	1.5 mile run	13:30	15:00
<b>Officer</b> US Army pre-commissioning APFT	2 min push-ups	40*	17*
	2 min sit-ups	50*	50*
	2 mile run	16:36*	19:36*
<b>Officer</b> US Marine Corps Initial Strength Test	Pull-ups or push ups	8 or 62	1 or 34
	2 min crunches	70	70
	3 mile run	24:00	27:00

\*Scoring is adjusted by age. These scores based upon 22-26 age group.

*Sources:* FM 7-22, Army Physical Fitness Test; Marine Administrative Message 670/16, Changes to the Physical Fitness Test, Combat Fitness Test, and Body Composition Program: Advisory 1-17.

Marine Corps enlisted recruits must pass the general Initial Strength Test (IST) prior to shipping to initial entry training.<sup>59</sup> Marine Corps applicants to the officer program must pass a slightly different IST prior to reporting to Officer Candidate School.<sup>60</sup> Naval Academy midshipmen compete for a Marine Corps commission based upon their scores from the Marine Corps physical fitness test (PFT), combat fitness test (CFT), and The Basic School obstacle course and endurance course.<sup>61</sup>

While each of the tests provides a threshold of physical fitness capacity prior to induction, each military service uses different assessments and the minimum scores are not standardized. In order to determine a baseline threshold of physical fitness capacity for draftees, especially in determination of which draftees will have better capacity for physically demanding combat jobs, institution of a baseline assessment is vital.

Between recruitment and movement to initial entry training, recruits are sent to a military entrance processing station (MEPS) to undergo screening prior to induction into the military.

The purpose of this screening is to attain mental-aptitude and medical-testing results. The

Department of Defense uses a quality spread of enlistees across the military services requisitioning personnel.<sup>62</sup> This method of manpower allocation is for current volunteer military service. Historically, during a draft the Department of Defense requisitioned personnel through the Selective Service System to allocate toward a manpower gap.<sup>63</sup> During World War II, the War Department used the draft initially to fill gaps in the regular Army and National Guard and subsequently for automatic and special requisition combat replacements.<sup>64</sup>

In addition to the ASVAB, recruits also undergo a medical examination to ensure candidates for enlistment are medically fit. Department of Defense Instruction 6130.03, *Medical Standards for Appointment, Enlistment, or Induction in the Military Services*, provides a comprehensive list of disqualifiers that prevent medically unfit persons from entering the military.<sup>65</sup> Given this extensive list, this essay makes the assumption that each draftee assessed into the military would be reasonably medically qualified for service, even into combat arms. However, the Department of Defense must determine a draftee's propensity for a combat position through other means.

### US Army

As of January 2017, the Army began administering a physical test to all recruits and cadets as a replacement for the 1-1-1 assessment test in order to better determine their fitness for physically demanding MOSs.<sup>66</sup> The new test, known as the Occupational Physical Assessment Test (OPAT), is an output from the Army female integration plan and contains physical tasks in which scoring is gender neutral. The overall program allocates all Army MOSs into categories based upon their physical requirements: heavy, significant, moderate, and unqualified. Soldiers seeking to attain an MOS in any of the categories other than unqualified must meet the OPAT minimum requirements for that MOS. Soldiers who seeks to change their MOS, are only

required to take the OPAT when the desired MOS category is higher than their current MOS category.

Table 2: OPAT Scoring Chart

MOS Category	Standing Long Jump	Seated Power Throw	Strength Deadlift	Interval Aerobic Run
Heavy	5'3"	14'9"	160 lbs	10:14 min/mile over 43 shuttles
Significant	4'7"	13'1"	140 lbs	10:20 min/mile over 40 shuttles
Moderate	3'11"	11'6"	120 lbs	10:27 min/mile over 36 shuttles

*Source:* Headquarters, Department of the Army Execution Order 202-16: Accessions Occupational Assessment Test (OPAT) Implementation

Per the requirements described in Table 2 and based upon all Army MOS 11X (infantry) specialties being in the heavy MOS category, draftees subject to the Army implementation plan would be required to achieve significant physical thresholds.<sup>67</sup> The heavy category would likely eliminate many small-stature draftees and those without robust upper-body strength and high maximal oxygen uptake/cardiovascular endurance.

In addition to combat arms screening based upon OPAT requirements, there may be additional physical requirements depending on the specialty and the method that the Army uses to implement female integration in the future.<sup>68</sup> Soldiers seeking to become special-forces operators, rangers, or airborne soldiers also must pass gender-neutral physical-assessment tests.<sup>69</sup> However the Army decides to implement any additional physical job specialty requirements to attain physically challenging jobs, it will detrimentally impact throughput of small stature and low physical capacity draftees.

### US Marine Corps

The Marine Corps's female integration plan places gender-neutral physical thresholds on everything from the IST for those seeking a combat arms job, pre-combat arms MOS school

screening, to combat arms MOS attainment. The ground combat arms IST standards compared to those of the general-purpose IST are stricter and have gender-neutral requirements.<sup>70</sup> Those recruits seeking a combat arms job will be required to achieve minimum requirements with the MOS classification standards (MCS) on their boot camp PFTs and CFTs.<sup>71</sup> In order to attain a combat arms MOS, a Marine must be able to complete additional MOS specific physical standards prior to completion of their MOS school.<sup>72</sup> These tiered requirements build on each other, narrowing the pool of eligible personnel to allow only the most physically capable to attain combat arms jobs. To attain the MOS of 0311, rifleman, a Marine would need to achieve all the requirements listed in Table 3.

Table 3: Marine Corps Combat Arms Physical Standards

Type	Event	Minimum
Ground Combat Arms IST	Pull-ups	3
	Crunches	44
	Ammo can lift	45
	1.5 mi run	13:30 min
Ground Combat Arms MCS	Pull-ups (from PFT)	6
	3 mi run (from PFT)	24:51 min
	Ammo can lift (from CFT)	60
	Movement to contact (from CFT)	3:26 min
	Maneuver under fire (from CFT)	3:12 min
MOS 0311 Rifleman Specific Physical Standards	Sprint 25 meters and evacuate a casualty 25 meters*	54 sec
	Lift MK-19 heavy machinegun from the deck to overhead height.	Pass
	Scale a 56" wall unassisted*	30 sec
	March 20 km*	5 hrs
	Run/rush for 300 meters through a course with an agility network*	3 min 54 sec

\*Conducted with fighting load and weapon (~64 lbs)

*Source:* Fragmentary Order 4 (Implementation) to Marine Corps Force Integration Campaign Plan, December 16, 2015

In addition to the combat arms MOS physical thresholds, the Marine Corps also places restrictions on personnel to be assigned to load-bearing units. The Marine Corps female

integration plan defines a load-bearing unit as a unit that will require a non-combat arms Marine to be able to perform physically demanding tasks outside of his/her regular duties.<sup>73</sup> The purpose of the load-bearing unit assignment criteria is to utilize PFT/CFT minimum thresholds to ensure those being assigned to certain combat arms units will have the physical capacity to be successful due to the physically demanding nature of the unit's mission.<sup>74</sup> These criteria only apply to infantry regiments and battalions, reconnaissance battalions, force-reconnaissance companies, combat engineer/assault companies, and raider battalions; they are shown in Table 4.

Table 4: Marine Corps Load Bearing Unit Assignment Criteria

Event	Minimum
3 mi run (from PFT)	26:05 min
Ammo can lift (from CFT)	60
Movement to contact (from CFT)	3:26 min
Maneuver under fire (from CFT)	3:12 min

*Source:* Fragmentary Order 4 (Implementation) to Marine Corps Force Integration Campaign Plan, December 16, 2015

The combination of combat arms standards and load-bearing unit assignment criteria poses additional hurdles to any draftees assigned to the Marine Corps beyond pre-induction physical requirements. In a general comparison to the Army's OPAT and potential high physical-demand screening criteria, the Marine Corps combat arms physical requirements are more stringent. This might lend itself toward the less-physically capable draftees being funneled into the Army to be utilized more fully in the combat arms specialties.

#### Proposed Assignment Criteria

Manpower managers can follow a general-assignment flow based on physical assessment and draft paradigm to properly assign female draftees inducted into the military force to units. If a female is inducted into the military, and she meets the physical requirements imposed by the military services to attain a combat arms specialty, she can be assigned to that combat arms specialty as fill rates require.

If that draftee does not meet the integration requirements and the draft is a combat casualty demand signal paradigm, then the draftee should be assigned to non-combat arms specialties as required by fill rates. If that draftee does not meet the integration requirements and the draft is a high-volume paradigm, then the draftee should be given a baseline physical assessment similar to the Air Force Incremental Weight Lift Test with additional cardiovascular stamina testing.

Draftees who meet the baseline requirements can be assigned to a combat unit with adapted organizational equipment that also has a force protection mission set, referred to here as a constabulary infantry battalion. Those within 10% of achieving baseline standards can train and re-test within three weeks. Those who pass the retest should be assigned to constabulary infantry battalions in support roles. Those who fail and those draftees more than 10% below baseline threshold should be assigned to combat service support specialties. This throughput should ensure not all female manpower is dedicated to combat service support, unnecessarily overwhelming those units with excess, and also maximizing female draftee combat power in constabulary infantry units.

### **Case Study: Israel Defense Forces**

The US military is not the first military to address integration of women into combat roles. More than a dozen other countries have integrated women into combat roles. Furthermore, Israel and Britain have both conscripted women during wartime. Nowadays, most nations' militaries have executed implementation plans, similar to the US experience, to integrate females into existing combat forces.<sup>75</sup> However, it is only the Israel Defense Forces (IDF) that has constructed units focused upon female manpower utilization in the combat arms realm. The

Caracal, Lions of the Jordan, and the future Cheetah Battalion are heavily staffed by female soldiers. The Israel Defense Forces has adjusted their missions from traditional infantry battalions in order to accommodate the gender physical and physiological differences inherent in the primarily female units.

The IDF did not integrate women into combat arms positions in order to generate female-only gender-isolated units but rather to gender-integrate females into combat units. During the IDF's phased experimental approach to integration, which worked toward a fully gender-integrated end state, the initial combat arms units with females were gender-isolated.<sup>76</sup> The Caracal Battalion, the IDF's first completely integrated combat unit, was formed in 2004 after the Israel parliament enacted gender-equality legislation, requiring females be permitted to join combat jobs.<sup>77</sup> The Caracal Battalion is responsible for guarding the Egyptian border with various missions ranging from smuggling prevention to refugee control and anti-terrorism.<sup>78</sup> The more recently integrated combat unit, Lions of the Jordan Battalion, a unit in the 417th Jordan Valley Brigade, received its first female combat soldiers in August 2015.<sup>79</sup> The unit is responsible for guarding the eastern portion of Israel along the Jordan Valley. The female soldiers reported as a unit subsequent to their completion of specialty training to the Valley in order to replace the armored reserve battalion on duty. The IDF is in the process of forming a third gender-integrated combat unit, the Cheetah Battalion, to guard the Arava Desert sector from the Dead Sea to Eilat along the Jordan border.<sup>80</sup> Finally, the IDF has announced the plans for activation of a fourth integrated combat unit in March 2017 for border security rumored to be called the Panther Battalion.<sup>81</sup> The IDF has now committed to standing up border units that consist of a majority of female combat soldiers.

The IDF established Caracal, Lions, and Cheetah battalions to serve as border guard light infantry units without the traditional general-purpose infantry missions of the rest of the IDF.<sup>82</sup> These specialized border units have replaced traditional units along the two largest borders of Israel, replacing Golani, Givati, paratroopers, and other IDF regular infantry units.<sup>83</sup> Border security is considered a high-risk combat mission to Israel, which is surrounded by potential belligerents, compared to America's border-patrol job of law enforcement and immigration control.<sup>84</sup> However, the perception is also that the gender-integrated units are only being employed along tranquil areas, as Israel has peace treaties with Egypt and Jordan. Additionally, regular combat units are being employed along borders in which combat is more likely, such as the Givati Brigade deployed along the Gaza Strip.<sup>85</sup> The gender-integrated units are being employed to guard the border but only in areas not considered risky.

The IDF determined some best practices, such as adaptation and mission limitation, during its experimental integration process. During the experimental gender-integration process, the IDF modified combat equipment and organizational equipment in order to accommodate physiological differences between men and women.<sup>86</sup> The IDF currently provides female combat soldiers with lighter and fitted protective gear to help their mobility and prevent injuries.<sup>87</sup> The IDF also established that male and female combat soldiers would need to accomplish the same training regardless of gender in both entry level and advanced training.<sup>88</sup> It has used a mixture of gender-neutral and gender-normed physical standards depending on what was being tested and the specialty.<sup>89</sup> The IDF has found that regardless of the gender neutral standards and challenging training, female soldiers have been able to perform most tasks that male soldiers performed and that additional physical training has helped close the physical gap.<sup>90</sup>

The gender-integrated units are considered light infantry with less operational capability than their heavier and general purpose infantry counterparts such as the infantry battalions with the Golani Brigade.<sup>91</sup> With the limited availability of specific tactics, techniques, and procedures on the IDF units, analysis of how exactly the gender-integrated units operate compared to the general-purpose infantry is not possible. The IDF has considered restricting general-purpose infantry jobs to males due to female physiological attributes such as body mass and bone density that put female soldiers at a physical capacity disadvantage.<sup>92</sup> The IDF has established tough gender-neutral physical standards for the toughest infantry units and as of 2017, there have been no female soldiers able to meet them.<sup>93</sup>

The IDF has found a less physically strenuous combat niche for female soldiers in the gender-integrated border security units, and that is where they reside. Those units have had equipment adaptation applied in the form of lighter and better-fitting protective gear to alleviate strain and injury. The border-security units, while considered combat units, have a limited set of missions compared to the general-purpose infantry units. These gender-integrated units have seen combat action twice but are largely deployed to peaceful locations that are considered low risk. As the number of female combat soldiers has risen, the IDF has continued to create these provisional combat units to accommodate large numbers of female soldiers with physical capacity and physiological limitations that preclude them from joining standard infantry.

### **Constabulary Infantry Battalion**

An examination of common missions and tasks for a regular infantry battalion is vital to determine the structure of battalion capable of both assisting the US mission in a major conventional military campaign but also maximizing numbers of not just female draftees but

draftees of either sex possessing physical capacity limitations. The Army Field Manual 3-31.20, *The Infantry Battalion*, as well as the Navy and Marine Corps Policy 3500.44B, *Infantry Training and Readiness Manual*, and the Marine Corps Warfighting Publication 3-11.1, *Infantry Company Operations*, provide a wealth of information on doctrinal terms, missions, and organization. What none of these publications provide, however, is specifics on what the physical requirements of each mission and task entail.

In order to reverse engineer an infantry unit that accounts for physiological and physical capacity limitations and that supports conventional operations, those limitations of the draftee must be matched with accommodations such as reduced personal protective equipment, reduced carried days of supply, imposed movement range restrictions, and increased ground-lift assets. What cannot be accommodated will further dictate what missions can be assigned. For instance, a mission that requires man-carry of an 81-millimeter mortar through dense terrain, negating the ability to use lift, the notional female battalion will not be able to accomplish. As was identified by the Marine Corps during its research into female-integration planning, accommodation is not particularly cost effective. This analysis, however, will not attempt to accommodate a maximum budgetary limit in formulating a female draftee utilization strategy.

The force structure, equipment authorizations, and menu of assignable missions for a female draftee unit can be refined from available lessons learned on the IDF's mixed gender battalions such as the Caracal and Lions of Jordan units. As with the IDF battalions, the notional constabulary infantry battalions designed for female draftee accommodation do not have to be staffed entirely by females but instead should draw upon draftee personnel of either sex that may be of smaller stature or have physical capacity constraints. Additionally, the unit would operationally benefit from male manpower with infantry leadership experience at the non-

commissioned officer and commissioned-officer level. For a large-scale mobilization in support of a major military campaign, female draftees deemed fit for unrestricted military service should be used to construct constabulary infantry battalions primarily focused upon force protection measures involving consolidating operational gains, commonly referred to as wide-area security.

### Definitions

To set the stage for devising a new unit based on the context outlined by the background of the draft, the likely physical capacity and physiological restrictions of female draftees, and the IDF gender integrated unit model, it is useful to examine US military infantry terminology.

#### *Regular or General Purpose Infantry Battalion*

The Marine Corps describes an infantry battalion in terms of its composition, its general mission, and how it can be modified. In the Marine Corps Reference Publication 5-12C, *Organization of Marine Corps Forces*, an infantry battalion is described as the Marine Corps's basic tactical ground combat unit consisting of a headquarters and service company, a weapons company, and three-to-four rifle companies; it is by design a foot-mobile unit.<sup>94</sup> It states that the infantry battalion conducts combined-arms operations by integrating with Marine aviation and can potentially be reinforced with other combat arms units.

The Army provides an entire field manual dedicated to the Army infantry battalion complete with definitions, organization, and missions. It describes an infantry battalion as the first level of command that includes a staff that supports a commander, a unit that can be applied against missions across the range of military operations, and an organization whose primary task is to “close with and destroy the enemy by fire and maneuver.”<sup>95</sup>

#### *Light Infantry*

This type of infantry unit is non-doctrinal and non-standardized. There are two schools of thought within the US Army: One believes that a unit is light infantry based upon its ease of

strategic mobility due to lack of heavy equipment while the other believes what makes a light infantry unit is its light, skirmish, and ambush-style tactics.<sup>96</sup> This latter unit does not require heavy equipment because of the nature of how it operates; therefore, its strategic mobility is an unintended beneficial consequence.

### Missions

The majority of restrictions to a potential mission set for a battalion made up of female draftees revolves around mobility and combat-load concerns. Appendix A lists a common set of infantry battalion missions generalized from the Field Manual on the Army infantry battalion. These missions fall into major categories of intelligence, surveillance, and reconnaissance; offensive operations; defensive operations; security operations; and miscellaneous missions. The appendix provides a general list of adaptations against mission set.

Primarily, a constabulary infantry battalion would need enough operational vehicles in order to mount or mechanize the entire force. Furthermore, restrictive terrain preventing vehicular movement, such as dense jungle or swampy terrain, would render a constabulary infantry battalion incapable of performing many of the missions in Appendix A. Additionally, dismounted operations would be restricted to limited ranges due to slower effective-movement speeds and challenging combat loads. In the event that there is no alternative to conducting a long-range mission and mounted operations are not possible, commanders of constabulary infantry battalions must make trade-offs such as reducing carried supplies, eliminating heavy protective equipment such as small-arms protective inserts, or adjusting the organization to send hardier military personnel on the longer ranging missions.

Other general modifications to constabulary infantry battalions will need to be applied to accommodate general physical capacity restrictions of its personnel. Constabulary infantry

battalions will need additional attachments such as engineers or reconnaissance personnel when a commander anticipates those missions must be undertaken. For urban operations, where there is an overabundance of multi-floored structures, constabulary infantry battalions should be deployed in large numbers to apply more personnel against the additional number of building floors to clear. Generally, constabulary infantry battalions should apply additional personnel compared with general-purpose infantry for sizeable attack and clearing areas and attach enablers where the organic capability is minimal such as attaching engineers for fortification building.

The constabulary infantry battalion will need to limit ranges, terrain, and carry loads of personnel executing dismounted movement. In 2007, the Naval Research Advisory Committee conducted a human performance effect review of recent operations by reviewing average carry loads of foot patrols. On average, members of a foot patrol taking five hours carried anywhere from 68 lbs. to as much as 134 lbs.<sup>97</sup> In order to reduce the strain on a constabulary infantry battalion foot patrol, members should limit their range, reduce protective equipment, and eliminate carried supplies, which would reduce the time a patrol could be outside of a defensive perimeter. Additionally, the battalion should try to conduct mounted movement as much as possible and only conduct dismounted operations in a limited manner.

The niche the constabulary infantry battalion would best fill would be in force protection of critical nodes, forward operating base security, vital main supply routes, and other essential operating areas. These suggested missions would enable the battalion to have ready access to vehicle-oriented terrain and sources of supply necessary to replenish resources to prevent culmination. The battalion could still provide provisional infantry support based upon the accommodations and limitations detailed in Appendix A.

## Task Organization

The general design of a constabulary infantry battalion differs from an Army or Marine Corps infantry battalion in the number of its line rifle companies, as shown in Appendix B. Army and Marine Corps infantry battalions consist of one headquarters company, three rifle companies, and one weapons company.<sup>98</sup> A constabulary infantry battalion also contains a headquarters and weapons company but is designed around four rifle companies. The additional rifle company allows a commander to more heavily weight a main effort or reserve with an additional company. The other added benefit is that with additional available personnel, battalion equipment can be spread-loaded during dismounted operations across more manpower, thus reducing the individual load.

The constabulary infantry battalion is intended to operate as both light infantry in terms of its tactics but also as a motorized unit. The battalion's line companies during dismounted operations, with limited range and light weapons, should be employed only in a light, skirmishing method. During mounted operations, the line companies should either be employed in twos or the reserve should be doubled so as to create options for the commander. Heavy indirect fire of vehicle-mounted 81-millimeter mortars would be consolidated at the headquarters company. This allows the commander greater control of the longer range that can be provided by 81-millimeter mortars and lightens the company of heavier equipment. Both the Army and Marine Corps rifle companies have heavy weapons. The Army places a section of 60-millimeter mortars in the company, whereas the Marine Corps has a weapons platoon with 60-millimeter mortars, medium machine guns, and shoulder-launched multipurpose assault weapons.<sup>99</sup> The constabulary infantry battalion rifle company has nothing larger than small arms within the companies. This allows the constabulary infantry battalion rifle companies much more mobility but reduced firepower at the rifle-company level.

To ensure mobility, the constabulary infantry battalion has additional motorized assets not found in an Army or Marine Corps infantry battalion. The constabulary infantry battalion has an added motor transportation platoon and a motorized reconnaissance platoon within the headquarters company. The motor transportation platoon's mission is to assist with mounted operations of the headquarters element and, secondarily, motor-transportation administrative matters such as licensing. The reconnaissance platoon is intended to be employed in vehicles but, with limited patrol ranges, it can be foot mobile as well. Additionally, the weapons company is also a motorized unit within the battalion with the intent to deploy its weapons, with the exception of the 60-millimeter mortars from vehicle mounts. Additional motorized assets are required to assist the battalion with the lift demands of fully mounted operations.

#### Aggregation and Piecemealing

Constabulary infantry battalions are not designed with the intent to aggregate into a larger regimental structure. This is due to the inherent mission limitations, terrain restrictions, and reduced firepower. However, line rifle companies could potentially be detached from a constabulary infantry battalion for use with a task force or attached to another combat arms construct in order to provide manpower for special missions. These companies could be utilized for tasks related to counterinsurgency recently assigned to female engagement teams, such as female searches at entry control points, human intelligence gathering, or female populace engagement.<sup>100</sup> However, reduction in the four-company construct shown in Appendix B further reduces the combat power of the battalion and increases risk. If constabulary rifle companies need to be detached for another mission, the constabulary battalion will have a further restricted mission set unless it also receives enabler attachments.

## Equipment

The constabulary infantry battalion differs from the Army and Marine Corps infantry battalion in the way it consolidates heavy equipment at a higher echelon. Both the Army and Marine Corps employ a triangular structure, and each includes heavy weapons at the platoon level for each rifle company.<sup>101</sup> The constabulary infantry battalion consolidates those heavy weapons assets within the weapons company and the headquarters and service company. This consolidation frees the rifle companies from heavy equipment to engage in skirmishing tactics of light infantry.

The composition of heavy weapons and indirect-fire assets of the unit must be modified from a traditional Army or Marine Corps infantry battalion to accommodate the reduced physical capacity to carry heavy equipment long distances. As 81-millimeter man-carried mortars and their associated equipment are prohibitively heavy, they should be eliminated from the constabulary infantry battalions table of equipment.<sup>102</sup> The elimination of the 81-millimeter mortar would reduce the range and quantity of organic indirect fire available to the battalion. To compensate, M1129 wheeled armored mortar carriers configured with an 81-millimeter mortar, capable of firing a mortar from the vehicle-mount, should be added to battalion.

## Challenges

The goal of the constabulary infantry battalion is to actually use female draftees – and male draftees that are also of smaller stature with physical limitations – in a combat unit that is providing operational benefit. As described in the background, a large number of female draftees would be inducted with every draft call. Pressing these draftees in large numbers into infantry battalions that provide no combat advantage is a fruitless endeavor. Additionally, not every billet within a constabulary infantry battalion can even be filled with a draftee, male or

female. The probability is high that commissioned and non-commissioned officers will be allocated from the active component, reserve force, or even the National Guard. An Army infantry battalion officer cadre is composed of approximately 10% commissioned officers and mid-to-senior level non-commissioned officers.<sup>103</sup> That leaves approximately 630 open billets for junior personnel to fill of a 700-member battalion. Of those open billets, draftees would likely not even fill all of them – not all would be entry-level billets. As the gender-integration programs within the military services are new, it will be years until female leadership within the combat arms is grown in significant numbers. These challenges to a constabulary infantry battalion pose significant questions regarding the battalion's concrete military advantage, proper manpower application, and direct leadership challenges.

In a gender-neutral draft mandated by law, there is no choice to be made regarding whether or not the military will utilize female manpower. The Department of Defense has an obligation to fill its operational gap with conscripted manpower in the most effective way possible. The operational gap would be the reason the military signaled to Congress that it needed to induct personnel in the first place. This may require the military to shift missions from unit to unit in the same way a cargo officer fits each piece of equipment in the restricted cargo space of a ship to optimize space. The US military should apply the constabulary infantry battalions as the IDF has learned to apply their gender-integrated battalions. The IDF utilizes them for lower-risk border security missions. This allows the IDF to apply heavier, more robust infantry units against higher-risk missions. The constabulary infantry battalions could be utilized in a similar way by applying them against forward operating base security, using mounted patrols, and keeping main supply routes secure. As the constabulary infantry battalions coalesce

and mature, the military could expand its mission set to assist the regular infantry battalions as needed.

During a draft, there will be friction between regular and reserve leadership and conscripts independent of the gender of the junior personnel. This issue is not unique to a constabulary infantry battalion. The US military's promotion systems that only permit those with leadership skills to rise to higher ranks must be relied upon to ensure a constabulary infantry battalion's success. It might also be prudent to further vet those military members who will join a draftee unit in a leadership role to ensure they possess the correct temperament to handle the exceptional challenges of such a new and unique construct. Ultimately, only training, testing, and operational application would determine the definitive realization of a constabulary infantry battalion.

### **Conclusion**

Should the United States decide to begin inducting personnel into the military using the Selective Service system, the Department of Defense will need a plan to apply personnel against manpower gaps. It is likely that, due to the societal movement toward gender equality and pending legal challenges to the current male draft system, the barrier to women conscripts will fall. Department of Defense force planners need to begin moving not just toward solidifying draftee manpower application, but draftee plans that include women as well. Serious consideration must be given to how the current gender-integration programs of the military services will impact draftee manpower plans. As currently established, a draftee would be fed through the gender-integration plan filter during entry-level training. As the integration plan

requirements to even achieve a combat MOS are stringent, the plans would likely eliminate female draftees that could otherwise be used to generate combat power.

Implementation of a gender-neutral draft will require modification to the training path of a new enlisted recruit. If a draftee cannot meet the gender integration plan physical requirements to attend a combat MOS school, s/he will not achieve the combat arms MOS and would be unable to be assigned to a constabulary infantry battalion. This implies that during a draft, the military services considering using a provisional unit modeled after the constabulary infantry battalion would need to establish a separate MOS. This improvised MOS would have different physical requirements that draw the most physically capable draftees not quite able to meet the integration plan requirements. However, the creation of a new MOS comes with a whole other host of issues to include infrastructure, cost, longevity, and training pipeline problems. To create a constabulary infantry battalion force, either draftees must be exempt from gender-integration plan requirements or a separate MOS with a different training pipeline must be established.

The measure of the constabulary infantry battalion comes down to its solvency. The creation of such a provisional unit will be expensive due to specialized equipment development and acquisition, separate training pipeline creation, and the large number of vehicle assets required for mobility. The constabulary infantry battalion must prove to provide efficacy to the operational mission in order for the Department of Defense to be willing to dedicate a significant portion of resources to their creation. The best recourse for the military is to place draftees who have physical capacity and physiological limitations into constabulary infantry battalions.

---

<sup>1</sup> Richard Sisk, "Mattis Pick Could See Senate Clash on Women in Combat, PTSD," *Military.com*, published December 1, 2016, <http://www.military.com/daily-news/2016/12/01/mattis-pick-could-see-senate-clash-on-women-in-combat-ptsd.html>.

---

Kassia Halcli, “Would Trump’s defense secretary push women back out of combat jobs?” *PBS Newshour*, published December 6, 2016, <http://www.pbs.org/newshour/updates/trumps-defense-secretary-push-women-back-combat/>.

Jeff Schogol, “New in 2017: Future of Marines' gender integration plan uncertain,” *Marine Corps Times*, published December 29, 2016, <https://www.marinecorpstimes.com/articles/women-in-marine-combat-jobs>.

<sup>2</sup> Chairman of the Joint Chiefs of Staff, *Joint Operating Environment 2035*, (Washington, DC: Joint Chiefs of Staff, July 14, 2016), [http://www.dtic.mil/doctrine/concepts/joe/joe\\_2035\\_july16.pdf](http://www.dtic.mil/doctrine/concepts/joe/joe_2035_july16.pdf), ii-iii.

Additionally, the United States Agency for International Development in its Conflict Assessment Framework “the vast majority of violent conflicts since 1945 have been intrastate rather than interstate in nature and, as such, the USG is far more likely to find itself responding to a civil war than one directly between or among states (although states frequently intervene in other states’ internal conflicts).”

Neil Levine, *Conflict Assessment Framework v2*, (Washington, DC: United States Agency for International Development, June 2012), 6.

<sup>3</sup> Karoun Demirjian, “Are Women Headed for the Draft? Support for the Idea Grows in Congress,” *Washington Post*, published April 28, 2016, [https://www.washingtonpost.com/news/powerpost/wp/2016/04/28/women-could-be-headed-for-the-draft-after-house-committee-vote/?utm\\_term=.d8ef606184cb](https://www.washingtonpost.com/news/powerpost/wp/2016/04/28/women-could-be-headed-for-the-draft-after-house-committee-vote/?utm_term=.d8ef606184cb).

<sup>4</sup> 478. *Rostker v. Goldberg*, 453 U.S. 57 (1981).

<sup>5</sup> National Coalition for Men and James Lesmeister v. Selective Service System and Lawrence G. Romo as Director of Selective Service System, (US Dist. Calif., 2013), [https://www.fpparchive.org/media/documents/us\\_military/Lawsuit%20of%20National%20Coalition%20for%20Men%20and%20James%20Lesmeister\\_Mark%20E.%20Angelucci\\_April%204,%202013\\_Law%20office%20of%20Marc.%20E.%20Angleucci.pdf](https://www.fpparchive.org/media/documents/us_military/Lawsuit%20of%20National%20Coalition%20for%20Men%20and%20James%20Lesmeister_Mark%20E.%20Angelucci_April%204,%202013_Law%20office%20of%20Marc.%20E.%20Angleucci.pdf).

<sup>6</sup> National Coalition for Men and James Lesmeister v. Selective Service System and Lawrence G. Romo as Director of Selective Service System, No. 13-56690, (9th Cir., 2016), <http://law.justia.com/cases/federal/appellate-courts/ca9/13-56690/13-56690-2016-02-19.html>.

<sup>7</sup> *Ibid.*, 3.

<sup>8</sup> Leo Shane, “Congress Drops Plans to Make Women Register for the Draft,” *Military Times*, published November 29, 2016, <http://www.militarytimes.com/articles/ndaa-women-draft-dropped>.

<sup>9</sup> Selective Service System, “Background of Selective Service,” *Selective Service System*, published 2016, accessed December 2016, <https://www.sss.gov/About/History-And-Records/Background-Of-Selective-Service>.

<sup>10</sup> Bernard Rostker, *I Want You! The Evolution of the All-Volunteer Force*, (Santa Monica, CA: RAND Corporation, 2006), 30-32.

<sup>11</sup> *Ibid.*, 561.

<sup>12</sup> *Ibid.*

<sup>13</sup> *Ibid.*, 561.

<sup>14</sup> *Ibid.*, 442-444, 564.

<sup>15</sup> *Ibid.*, 564.

<sup>16</sup> Department of Veterans Affairs, *America’s Wars*, (Washington DC: Department of Veterans Affairs, May 2016), [https://www.va.gov/opa/publications/factsheets/fs\\_americas\\_wars.pdf](https://www.va.gov/opa/publications/factsheets/fs_americas_wars.pdf).

---

Selective Service System, "Induction Statistics," *Selective Service System*, published 2016, accessed December 2016, <https://www.sss.gov/About/History-And-Records/Induction-Statistics>.

<sup>17</sup> Nese F. DeBruyne and Anne Leland, *American War and Military Operations Casualties: Lists and Statistics*, CRS Report for Congress RL32492, (Washington, DC: Congressional Research Service, January 2, 2015), <https://fas.org/sgp/crs/natsec/RL32492.pdf>.

<sup>18</sup> Ibid.

<sup>19</sup> Janie Blankenship, "Draftees: Invaluable Contributors to the Nation's Defense." *VFW, Veterans of Foreign Wars Magazine* 96, no. 5 (January 2009), 14-15.

<http://search.proquest.com.lomc.idm.oclc.org/docview/204888109?accountid=14746>.

Kevin Baker, "The Case for the Draft." *American Heritage* 54, no. 3 (June 2003), 16.

<http://search.proquest.com.lomc.idm.oclc.org/docview/202706922?accountid=14746>.

<sup>20</sup> Laura Schumm, "Food Rationing in Wartime America," *History.com*, published 2014, <http://www.history.com/news/hungry-history/food-rationing-in-wartime-america>.

<sup>21</sup> Michael S. Neiberg, review of *The "Good War" in American Memory*, by John Bodnar, *Journal of Social History* 45, no. 3 (2012): 870-872.

<sup>22</sup> Marvin A. Kreidberg and Merton G. Henry, *History of Military Mobilization in the United States Army: 1775-1945*, Department of the Army Pamphlet No 20-212 (Washington, DC: Headquarters, Department of the US Army, November 30, 1955), 486, 501, 541.

<sup>23</sup> The National World War II Museum, "By the Numbers: The US Military," *The National WWII Museum*, accessed December 2016,

<http://www.nationalww2museum.org/learn/education/for-students/ww2-history/ww2-by-the-numbers/us-military.html>.

Veterans Affairs, *America's Wars*.

<sup>24</sup> David R. Segal and Mady Wechsler Segal, "U.S. Military's Reliance on the Reserves," *Population Reference Bureau*, accessed December 2016,

<http://www.prb.org/Publications/Articles/2005/USMilitarysRelianceontheReserves.aspx>.

<sup>25</sup> Military Selective Service Act, 50 USC § 3801 (2012), <http://legcounsel.house.gov/Comps/Military%20Selective%20Service%20Act.pdf> section 16, (a), 34.

<sup>26</sup> Headquarters, Department of the US Army, *Army Demographics, FY15 Army Profile*, (Washington, DC: Headquarters, Department of the US Army, September 30, 2015),

<http://www.armyg1.army.mil/hr/docs/demographics/BlueFinalFY15APR.pdf>.

<sup>27</sup> Martin Binkin and Shirley J. Bach, *Women and the Military*, (Washington, DC: Brookings Institution, 1977), 72.

<sup>28</sup> Ibid.

<sup>29</sup> Ibid., 75.

<sup>30</sup> Ibid., 77.

<sup>31</sup> American Psychological Association, "Think Again: Men and Women Share Cognitive Skills," *American Psychological Association*, published August 2014,

<http://www.apa.org/action/resources/research-in-action/share.aspx>.

<sup>32</sup> Ibid.

<sup>33</sup> Ibid.

<sup>34</sup> Binkin, *Women and the Military*, 78.

<sup>35</sup> Ibid., 80.

<sup>36</sup> Ibid.

- 
- <sup>37</sup> Ibid.
- <sup>38</sup> Ibid., 81-82.
- <sup>39</sup> Ibid., 36.
- <sup>40</sup> Joe McDaniel, Richard J. Skandis, and Scott W. Madole, *Weight Lift Capabilities of Air Force Basic Trainees*, (Wright-Patterson AFB, OH: Air Force Aerospace Medical Research Laboratory, May, 1983), 9.
- <sup>41</sup> J.H. Wilmore, "Alterations in Strength, Body Composition and Anthropometric Measurements Consequent to a 10-week Weight Training Program," *Medicine and Science in Sports F.*, no. 2 (1974): 133-138.
- <sup>42</sup> McDaniel, *Weight Lift Capabilities*, 33.
- <sup>43</sup> Thomas S. Szayna, Eric V. Larson, Angela O'Mahony, Sean Robson, Agnes Gereben Schaefer, Miriam Matthews, J. Michael Polich, Lynsay Ayer, Derek Eaton, William Marcellino, Lisa Miyashiro, Marek Posard, James Syme, Zev Winkelman, Cameron Wright, Megan Zander Cotugno, and William Welser IV, *Considerations for Integration of Women into Closed Occupations in the US Special Operations Forces*, (Santa Monica, CA: RAND Corporation, May 2015), 49.
- <sup>44</sup> Ibid.
- <sup>45</sup> Ibid., 50.
- <sup>46</sup> Ibid., 51.
- <sup>47</sup> Ibid., 58.
- <sup>48</sup> Ibid., 54.
- <sup>49</sup> Ibid.
- <sup>50</sup> Ibid.
- <sup>51</sup> Ibid., 33.
- <sup>52</sup> McNulty, Andrew. *Adaptability Study Update*. Staff Study, Deputy Commandant, Combat Development and Integration, February 2015.
- <sup>53</sup> Szayna, *Considerations for Integration of Women*, 64-65.
- <sup>54</sup> Ibid., 65.
- <sup>55</sup> Binkin, *Women and the Military*, 85.
- <sup>56</sup> Women In International Security Combat Integration Initiative, *Combat Integration Handbooks: A Leader's Guide to Success*, (Washington, DC: Women In International Security Global, September 2016), 44.
- <sup>57</sup> Headquarters, Department of the US Army. *Army Pocket Physical Training Guide*, (Washington, DC: Headquarters, Department of the US Army, January 2011), [https://www.goarmy.com/content/dam/goarmy/downloaded\\_assets/pt\\_guide/pocket-pt-guide.pdf](https://www.goarmy.com/content/dam/goarmy/downloaded_assets/pt_guide/pocket-pt-guide.pdf), 4-5.
- US Army Recruiting Command, *2015-2016 Pocket Recruiter Guide*, (Fort Knox, KY: US Army Recruiting Command, 2015), <http://www.usarec.army.mil/hq/apa/download/PRG15-16.pdf>.
- <sup>58</sup> US Army Training and Doctrine Command, *Institutional Leader Training and Education*, TRADOC Regulation 350-10, August 12, 2002, 19.
- <sup>59</sup> Commanding General, Marine Corps Combat Development Command, *Changes to the Physical Fitness Test, Combat Fitness Test, and Body Composition Program: Advisory 1-17*, MARADMIN 670/16, December 20, 2016, <http://www.marines.mil/News/Messages/Messages-Display/Article/1036121/changes-to-the-physical-fitness-test-combat-fitness-test-and-body-composition-p/>.

---

<sup>60</sup> Ibid.

<sup>61</sup> US Naval Academy, “Marine Selection,” *United States Naval Academy*, accessed January 1, 2017, <https://www.usna.edu/USMC/Selection.php>.

<sup>62</sup> US Department of Defense, *Personnel Procurement: Military Entrance Processing Station (MEPS)*, Army Regulation 601–270, OPNAVINST 1100.4C CH-2, AFI 36-2003\_IP, MCO 1100.75F, COMDTINST M 1100.2E, September 13, 2011, 36.

<sup>63</sup> Leonard L. Lerwill, *The Personnel Replacement System in the United States Army*, Department of the Army Pamphlet No 20-211 (Washington, DC: Headquarters, Department of the US Army, August 30, 1954), 57.

<sup>64</sup> Ibid., 205-206.

<sup>65</sup> US Department of Defense, *Medical Standards for Appointment, Enlistment, or Induction in the Military Services*, Instruction 6130.03 w/CH1, April 28, 2010.

<sup>66</sup> David Vergun, “Army Implements New Fitness Standards for Recruits and MOS Transfers,” TRADOC News Center (blog), January 3, 2017, <http://tradocnews.org/tag/occupational-physical-assessment-test/>.

<sup>67</sup> Chief of Staff of the Army, *Accessions Occupational Physical Assessment Test (OPAT) Implementation*, HQDA EXORD 202-16, June 16, 2016.

<sup>68</sup> Chief of Staff of the Army, *US Army Implementation Plan 2016-01 (Army Gender Integration)*, HQDA EXORD 097-16, March 9, 2016.

<sup>69</sup> US Army Special Operations Recruiting Battalion, “Qualifications,” *Special Operations Recruiting Battalion (Airborne)*, published 2016, [http://www.sorbrecruiting.com/SF\\_Qualifications.htm](http://www.sorbrecruiting.com/SF_Qualifications.htm).

US Army Maneuver Center of Excellence, “Ranger School Preparation,” *US Army Maneuver Center of Excellence*, published September 19, 2016, <http://www.benning.army.mil/infantry/rtb/content/PDF/Ranger%20School%20Prep%201%202.pdf>.

75th Ranger Regiment, “Ranger Assessment & Selection Program,” *US Army, 75th Ranger Regiment*, published July 23, 2015, <http://www.goarmy.com/ranger/training/rasp.html>.

US Army Maneuver Center of Excellence, “BAC Entrance Requirements,” *US Army Maneuver Center of Excellence*, published November 29, 2016, <http://www.benning.army.mil/infantry/rtb/1-507th/airborne/entrancereq.html>

<sup>70</sup> CG, MCCDC, *Changes to the Physical Fitness Test*.

Commandant of the Marine Corps, *Fragmentary Order 4 to Marine Corps Force Integration Campaign Plan*, FRAGO 4 (Implementation) December 16, 2015, C-1, C-3.

<sup>71</sup> Ibid., C-4.

<sup>72</sup> Ibid., Appendix 2 to Annex C.

<sup>73</sup> Ibid., C-6.

<sup>74</sup> Ibid.

<sup>75</sup> Agnes Gereben Schaefer, Jennie W. Wenger, Jennifer Kavanagh, Jonathan P. Wong, Gillian S. Oak, Thomas E. Trail, Todd Nichols, *Implications of Integrating Women into the Marine Corps Infantry*, RAND Corporation, 2015, 49-86.

<sup>76</sup> Ibid., 63.

<sup>77</sup> Judah Ari Gross, “On Egypt Border, Mixed-Gender Unit Fights Old Ideas and New Foes,” *The Times of Israel*, published October 30, 2016, <http://www.timesofisrael.com/on-egypt-border-mixed-gender-troops-fight-old-ideas-and-new-foes/>.

---

<sup>78</sup> Tsivya Fox, “Israel’s Cutting Edge Co-Ed Combat Battalions,” *Breaking Israel News*, published July 14, 2016, <https://www.breakingisraelnews.com/71838/israels-cutting-edge-co-ed-combat-battalions/#V84KAdY2kYy4dXLQ.97>.

<sup>79</sup> Hana Levi Julian, “Lions of Jordan Battalion Guard Israel’s Jordan Valley,” *The Jewish Press*, published August 5, 2015, <http://www.jewishpress.com/news/breaking-news/lions-of-jordan-battalion-guard-israels-jordan-valley/2015/08/05/>.

<sup>80</sup> Ibid.

Gross, “On Egypt Border, Mixed-Gender Unit.”

<sup>81</sup> Michael Blum, “Women Increasingly Join the Fight in Israel’s Army,” *The Times of Israel*, published November 20, 2016, <http://www.timesofisrael.com/women-increasingly-join-the-fight-in-israels-army/>.

<sup>82</sup> Israel Defense Forces, “What’s New? Top 6 Exciting Changes of the Year,” *Israel Defense Forces* (blog), September 18, 2015, <https://www.idfblog.com/2015/09/18/whats-new-top-6-exciting-changes-year/>.

<sup>83</sup> Gross, “On Egypt Border, Mixed-Gender Unit.”

<sup>84</sup> Becca Noy, “Get To Know the IDF Infantry Corps Brigades: Golani, Givati, Kfir, Nahal, Tzanchanim,” *Jerusalem Online*, published January 8, 2017, <http://www.jerusalemonline.com/news/politics-and-military/military/get-to-know-the-idf-infantry-corps-brigades-25818>.

<sup>85</sup> Gross, “On Egypt Border, Mixed-Gender Unit.”

<sup>86</sup> Ibid.

<sup>87</sup> Judah Ari Gross, “New Combat Positions For Women in the IDF, Same Old Obstacles,” *The Times of Israel*, published March 13, 2016, <http://www.timesofisrael.com/new-combat-positions-for-women-in-the-idf-same-old-obstacles/>.

<sup>88</sup> Judy Maltz, “IDF’s Mixed-sex Combat Battalion Lures New Immigrants, Challenge-seekers,” *Haaretz*, published September 3, 2015, <http://www.haaretz.com/israel-news/1.674171>.

<sup>89</sup> Schaefer, *Implications of Integrating Women*, 63.

<sup>90</sup> Ibid., 63-64.

<sup>91</sup> Ibid.

<sup>92</sup> Gross, “New Combat Positions.”

<sup>93</sup> Ibid.

<sup>94</sup> Headquarters US Marine Corps, *Marine Corps Supplement to the DOD Dictionary of Military and Associated Terms*, Marine Corps Reference Publication 5-12C, (Washington, DC: Headquarters US Marine Corps, November 16, 2011), Section II-32.

<sup>95</sup> Headquarters, Department of the US Army, *The Infantry Battalion*, Field Manual 3-21.20, (Washington, DC: Headquarters, Department of the US Army, December 2006), 1-1.

<sup>96</sup> Scott R. McMichael, *A Historical Perspective on Light Infantry*, Combat Studies Institute Research Survey (Fort Leavenworth, KS: US Army Command and General Staff College, 1951), xi-xii, xi.

<sup>97</sup> Naval Research Advisory Committee (NRAC), *Human Performance Effects*, staff study, Office of Naval Research, 2007, 2.

<sup>98</sup> HQDA, *The Infantry Battalion*, Figure 1-1, 1-3.

Headquarters US Marine Corps, *Organization of the United States Marine Corps*, Marine Corps Reference Publication 5-12D, (Washington, DC: Headquarters US Marine Corps, August 26, 2015), Figure 5-4, 5-6.

---

<sup>99</sup> Ibid.

<sup>100</sup> Stephanie Erwin, “The Veil of Kevlar: An Analysis of the Female Engagement Teams in Afghanistan,” (master’s thesis, Naval Postgraduate School, Monterey, CA, March 2012), <http://www.dtic.mil/dtic/tr/fulltext/u2/a560637.pdf>, 12-13.

<sup>101</sup> Ibid.

HQMC, *Organization of the United States Marine Corps*, Figure 5-4, 5-6.

<sup>102</sup> Headquarters, Department of the US Army, *Field Maintenance, 60-mm Mortars M2 and M19; 60-mm Mortar Mount M5; 60-mm Mortar Baseplate M1; 81-mm Mortars M1 and M29; and 81-mm Mortar and Mounts M3, M23A1, M23A2, and M23A3*, Technical Manual 9-3071-1, (Washington, DC: Headquarters, Department of the US Army, January 1967), 11. This technical manual lists the weight of an M1 81 mm mortar and an M4 mount as being 132 lbs. It lists the base plate as 45 lbs. The technical manual lists the weight of an M29 81 mm mortar and an M2SA1 mount as being 107 lbs and the base plate as 48 lbs.

<sup>103</sup> US Army Maneuver Center of Excellence, *Maneuver Center of Excellence Supplement Manual 3-90 Force Structure Reference Data*, (Maneuver Center of Excellence, Fort Benning, GA, October 2016), 9.

### Appendix A: Missions and Adaptation

Major Category	Sub-category	Physical Constraint(s)	Adaptation/Limitation	Result
Intel, Surveillance, Reconnaissance Ops	None	Combat load, significant ranging (150k)	Attach recon detachment Leverage other ISR assets	Non-organic surveillance for long range ISR
Offensive Ops	Envelopment	Long ranges, difficult terrain	Maximize lift assets	Do not conduct unless terrain supports mounted operations to carry supplies
	Penetration	Long duration attacks require additional ammunition	Carry additional ammo days of supply on lift assets	For projected long fights, carry additional ammo on vehicles
	Turning & Infiltration Ops	Dislocated detachment behind enemy forces requires additional days of supply	Carry additional supplies on lift assets	Do not conduct unless terrain supports mounted operations to carry supplies
	Frontal Attack	Long durations attacks require additional ammunition	Maximize lift assets	Do not conduct unless terrain supports mounted operations to carry supplies
	Hasty	Movement speed, range limitations	Maximize lift assets	Limited ranges without vehicles Plan must account for slower dismounted movement speed
	Deliberate	Range limitations	Maximize lift assets	Limited dismounted range

### Appendix A: Missions and Adaptation

Offensive Ops (continued)	Movement to Contact	Combat load, movement speed, range limitations	Maximize lift assets	Limited dismounted range Plan must account for slower dismounted movement speed
	Consolidation	None	None	No restrictions
Defensive Ops	Area Defense	Fortification time	Attach engineer detachment	Plan must account for slower defensive fortification
	Forward Defense	Combat load, terrain issues and ranging with screening unit	Maximize lift assets	Limited screening dismounted range
	Defense in Depth	Counterattack force mobility restrictions Fortification time	Mounted counterattack force Attach engineer detachment	Contingent on permissive terrain for counterattack force Plan must account for slower defensive fortification
	Battle Handover Passage of Lines	None	None	No restrictions
	Mobile Defense	Counterattack force mobility restrictions Fortification time	Mounted counterattack force Attach engineer detachment	Contingent on permissive terrain for counterattack force Plan must account for slower defensive fortification

### Appendix A: Missions and Adaptation

Defensive Ops (continued)	Retrograde	Movement speed	Maximize lift assets	Plan must account for slower dismounted movement speed
Security Ops	Humanitarian/Relief	None	None	No restrictions
	Security Assistance	None	None	No restrictions
	Noncombatant Evac	Casualty carry	None	Recommend not to conduct noncombatant evac unless a part of a larger unit
	Patrol	Range limitations	Maximize lift assets	Limited range for dismounted ops
	Observation Post	Range limitations	Maximize lift assets	Limited range for dismounted ops
	Searches	Potential hand-to-hand combat	Overwatch	Ensure additional personnel available for overwatch
Miscellaneous	Roadblocks	None	None	No restrictions
	River crossing	Mobility in water	Ensure unit is swim qualified	Mandate swim qualification
	Fire support	Heavy equipment	Utilize vehicles to transport equipment Use only 60 mm mortars	Less organic IDF support Smaller ranges of organic IDF
	Urban Ops	Vertical equipment carry	Utilize more units to cover large vertical construction	More constabulary units per city blocks

*Source:* Field Manual 3-21.20: The Infantry Battalion, December 2006



## Appendix B: Organization

US Marine Corps Infantry Battalion<sup>2</sup>

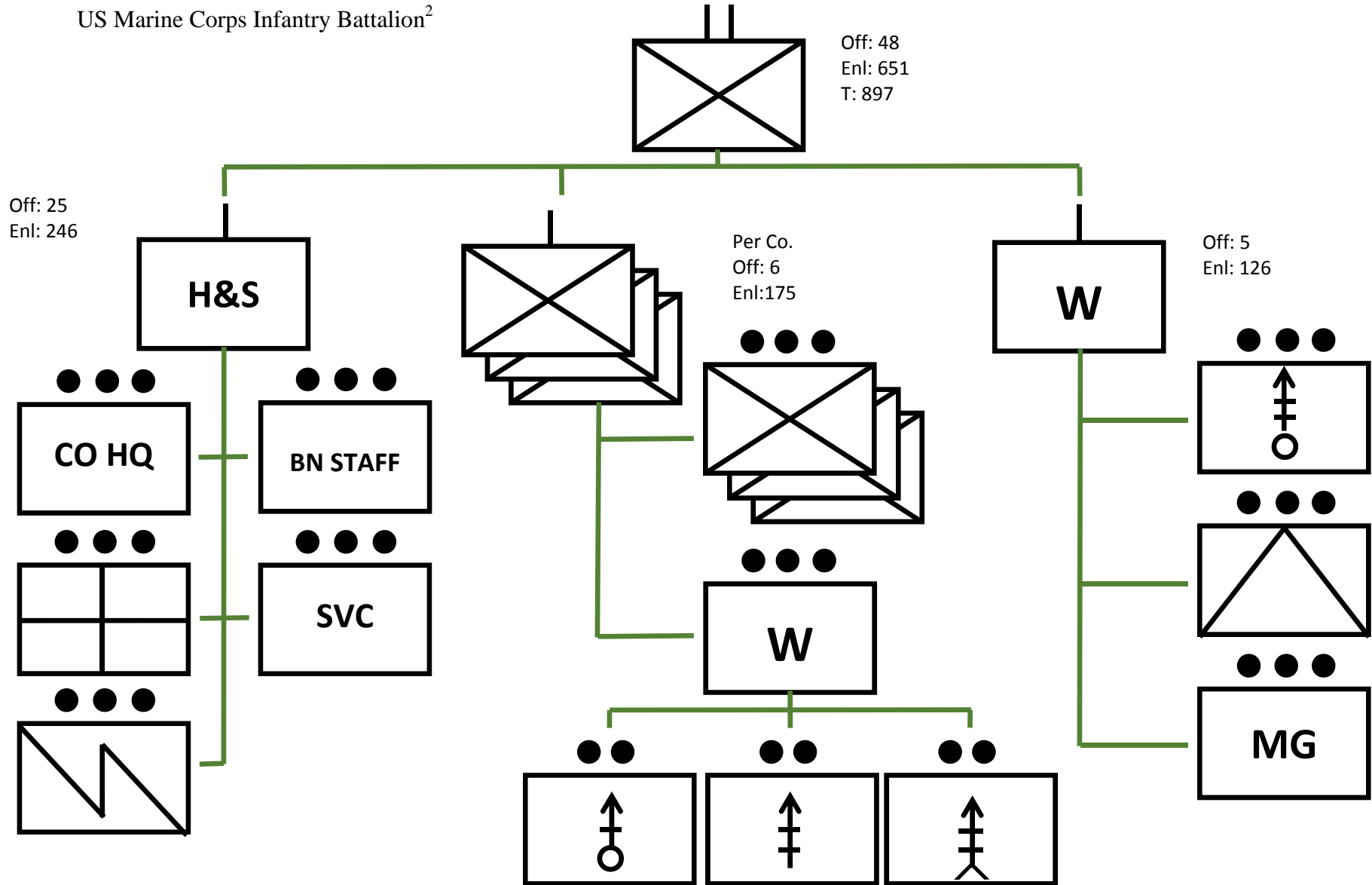

## Appendix B: Organization

Constabulary Infantry Battalion

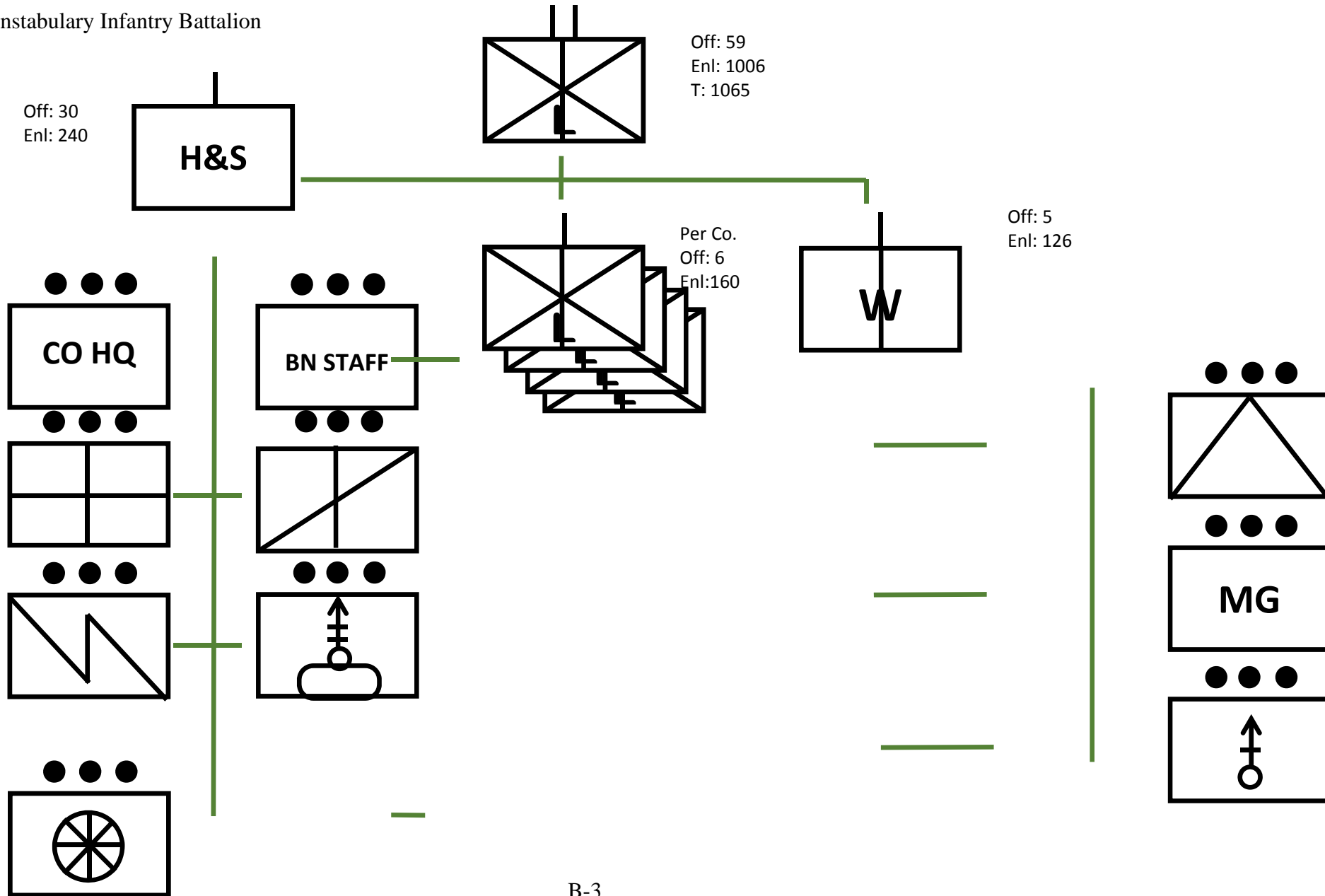

---

<sup>1</sup> Headquarters, Department of the US Army, *The Infantry Battalion*, Field Manual 3-21.20, (Washington, DC: Headquarters, Department of the US Army, December 2006), Figure 1-1, 1-3.

<sup>2</sup> Headquarters US Marine Corps, *Organization of the United States Marine Corps*, Marine Corps Reference Publication 3-11.1, (Washington, DC: Headquarters US Marine Corps, August 26, 2015), Figure 5-4, 5-6.

Headquarters US Marine Corps, *Infantry Company Operations*, Marine Corps Warfighting Publication 3-11.1, (Washington, DC: Headquarters US Marine Corps, October 6, 2014), 1-5:13.

Headquarters US Marine Corps, *Total Force Structure Management System: M11110 1/1 1st Marine Division*, (Washington, DC: Headquarters US Marine Corps, October 1, 2016).

## Glossary

1-1-1 Assessment Test – Test given by US Army recruiters to determine a prospective recruit’s physical propensity for success at initial entry training. It consists of one minute of sit-ups, one minute of push-ups, and a timed one mile run.

Accommodation – Adaptation, adjustment, or provision to lessen the detrimental impact of a physical or physiological limitation.

Active Component (AC) – Standing forces of the US military that are permanently on active duty. These forces are sometimes incorrectly referred to as active duty. However, active duty is a duty status and both active and reserve component forces can be in an active duty status.

Aggregation – Integration of forces together into a larger cohesive unit.

All Volunteer Force (AVF) – US military force established in 1973 after expiration of the draft induction authority. The force is comprised solely of volunteer military members as opposed to a portion of the force consisting of draftees.

Anaerobic – Referring to non-endurance, short-term/high-intensity activity.

Armed Forces Qualification Test (AFQT) – Sub-test of the Armed Services Vocational Aptitude Battery utilizing a combination of arithmetic reasoning, math knowledge, and verbal composite scores to determine military eligibility.

Armed Services Vocational Aptitude Battery (ASVAB) – Set of tests that measure a military applicant’s propensity for certain military occupations and his or her propensity for success in the military.

Army Chief of Staff (CSA) – Also Chief of Staff of the US Army. Top ranking four star US Army general who serves as both a member of the Joint Chiefs of Staff and an advisor to the Secretary of the Army.

Body Mass – Body weight and size.

Bradley Fighting Vehicle (BFV) – Tracked and armored vehicle used by the US Army to transport troops and provide cover fire. It possesses a 25-millimeter chain gun and a TOW as the primary weapons.

Brookings Institution – Washington, DC-based research institution, or think tank, that provides research into the social sciences.

Caracal Battalion – Israel Defense Forces border security combat unit stood up in the early 2000s as an experimental unit to test gender integration. This unit’s mission is to guard the border Israel shares with Egypt. It was the first of now four planned border security gender-integrated

units. Currently, there are also the Lions of the Jordan and Cheetah Battalions with a fourth battalion planned for activation.

Central All-Volunteer Force Task Force (CAVFTF) – Organization, stood up in 1972 by Secretary of Defense Melvin Laird, with the mission to develop manpower policy and practices that would allow the Department of Defense to execute national strategy without a draft to support it.

Combat Arms – Referring to those forces designed for the participation in direct ground combat.

Combat Development and Integration (CD&I) – Headquarters Marine Corps organization directed by a three-star general with the purpose of developing the Marine Corps force and its capabilities.

Combat Fitness Test (CFT) – Physical fitness test implemented by the Marine Corps in 2009 that seeks to determine a Marine’s capability to endure combat operational rigors. It has three elements that consist of a sprint, lifting an ammunition box overhead multiple times, and a short/high-intensity weighted obstacle course.

Commandant of the Marine Corps (CMC) – Top ranking four star US Marine Corps general who serves as a member of the Joint Chiefs of Staff. This general also reports to the Secretary of the Navy.

Commissioned Officer – Military leader who has received through an approved commissioning source (such as Officer Candidate School or a Service Academy) an official document of appointment known as a commission and is typically authorized to command a unit in the US military.

Conscript – Military member who has been enlisted compulsorily into the armed forces.

Department of Defense (DoD) – US organization under the Executive Branch in charge of national security and the US military.

Draft – Conscription of personnel into the military.

Draftee – See conscript.

Enlistment – Act of or contract pertaining to the enrollment into the armed forces.

Equal Protection Clause – Portion of the 14th Amendment to the US Constitution that no state may deny a person equal protection of the law. The Supreme Court has also ruled that under the 5th Amendment’s Due Process Clause, these protections also apply to the federal government.

Factor X – Additional test added by the US Air Force to recruit physical screening to determine a recruit’s ability to perform physically demanding jobs.

Gates Commission – Body formed by President Nixon in 1970 to determine the efficacy of an all-volunteer military force.

Gender Integration – Policy of allowing both men and women equal opportunity to all job positions. This refers to allowing women after a previous policy of restricting their participation in some way.

General Purpose Infantry – Basic direct combat unit whose mission is to close with and destroy the enemy.

Givati – Infantry brigade in the Israel Defense Forces who serve as that military's amphibious force. Members can be identified by their purple berets and fox unit symbol.

Golani – Infantry brigade in the Israel Defense Forces who serve as a regular infantry unit. Members can be identified by their brown berets and olive tree unit symbol.

Health and Comfort Pack – Non-food hygiene necessity package for forward deployed units.

Incremental Weight Lift Test – Tiered strength test developed by the US Air Force that improved on the Factor X test given to recruits to determine their propensity for physically demanding jobs.

Induction – Ceremony in which a recruit is enlisted into the military.

Initial Strength Test (IST) – Test given by US Marine Corps recruiters to military applicants to determine if they will be inducted into the Marine Corps.

Israel Defense Forces (IDF) – National military of the state of Israel.

Javelin – Man-portable shoulder-fired infrared-guided anti-armor missile.

Joint Chiefs of Staff (JCS) – Organization of staff consisting of a Chairman, Vice Chairman, and the senior uniformed flag officer of each military service. This organization advises the President of the United States and the Department of Defense on military matters.

Light Infantry – Type of infantry that possess minimal equipment and utilizes harassing or skirmishing tactics against the enemy.

Constabulary Infantry – Type of infantry that primarily focuses on wide area security and utilizes accommodation in terms of equipment and/or mission to alleviate an otherwise detrimental problem.

Marine Corps Force Integration Office (MCFIO) – US Marine Corps organization established to assess the integration of female Marines into previously closed occupations.

Maximal Oxygen Update – Also VO2 Max. Amount of oxygen a person’s body uses during aerobic exercise. It is correlated to how well a person can perform short-term and high-intensity activity.

Mechanized Infantry – Type of infantry that is equipped with armored vehicles for mobility and protection.

Military Entrance Processing Station (MEPS) – Location where a military applicant receives the ASVAB, physical screening, and then potentially inducted into the military prior to beginning entry level training.

Military Occupational Specialty (MOS) – Job category in the US Army and Marine Corps.

Military Selective Service Act – 50 USC 3801, as amended August 10, 2012, Public law that allows the Selective Service System to require a certain subset of the populace to register for a potential draft. It contains provisions for how a draft were to operate if induction authority is given in the future.

Military Service – Refers to the US Army, US Air Force, US Navy, and US Marine Corps as branches of the Department of Defense.

Mobilization – Act of preparing and organizing the military and possibly the industrial sector of the country in anticipation or actualization of war.

Mortar – Short-tubed, smooth-bored, large caliber gun capable of indirectly launching projectiles of various sorts at an enemy at high angles.

MOS Classification Standards (MCS) – Set of physical standards established by the US Marine Corps for each military job based on the specific physical demands of that job.

MOS School – Entry level school a military member attends upon graduation from initial entry training to learn MOS-specific skills. This school produces a military member that possesses the skills necessary for MOS success.

Motorized Infantry – Type of infantry that is designed to perform mounted operations on wheeled, and typically unarmored, vehicles.

National Guard – US Army reserve component and federally recognized force that consists of active and inactive militia forces. It consists of both the Army National Guard and Army Air National Guard.

National Defense Authorization Act (NDAA) – Annual law containing allowed budget expenses of the Department of Defense.

Neutrality Act – Laws passed by US Congress prior to World War II to prevent US involvement in foreign wars.

Non-Commissioned Officer (NCO) – Military enlisted leaders that do not possess a commission or warrant.

Occupational Physical Assessment Test (OPAT) – US Army gender neutral physical test that measures a member's ability to perform physically demanding jobs.

Physical Fitness Test (PFT) – Physical assessment given to military members on which to determine their general health and used as an administrative readiness measure. Scores are typically normed by age group and gender. Method of assessment differs by military service.

Physiology – Study of human biological systems and how they function.

Piecemealing – Refers to the detachment of one or more subordinate unit(s) (e.g. company) from a provisional unit (e.g. battalion) for special use in a task force or different unit.

Protective Mobilization Plan (PMP) – War plan developed during the Interwar Period to mobilize US Army troops and equipment in support of a potential war.

PUHLES Profile – Acronym standing for Physical capacity/stamina, Upper extremities, Lower extremities, Hearing/ear, Eyes, Psychiatric. Medical physical profile built on military applicants.

Prima Facie – Latin phrase meaning presumed to be true until disproven.

Regular Army – Active Component US Army.

Reserve Component (RC) – US military forces that are part time forces or can be on part time or permanent active duty to support the reserve component. Reserve component forces can also be called to active duty for training, operations, or other commitments.

Rifle Company – General purpose infantry company.

Secretary of Defense (SECDEF) – Civilian appointee who is the head of the Department of Defense.

Selective Service System – Agency established to manage the registration and possible future mobilization of military manpower in support of a national emergency.

Special Operations Command (SOCOM) – Unified US combatant command in charge of special operations missions.

Stryker Infantry Carrier – Armored fighting vehicle used by the US Army to transport personnel and engage the enemy. Primary armament is a 105-millimeter main gun, 0.50-inch machine gun, or a MK19 grenade launcher.

Task Organization – Structural hierarchy of a set of units and their subordinates based on operational responsibilities.

Tech Mech/Tank – US Marine Corps cross attached company level units in which the preponderance of the company defines its name (e.g. unit with mostly tanks is team tank).

TOW – Acronym standing for Tube-launch, Optically-guided, Wire-guided missile. Weapon is an anti-tank guided missile that can be fired from a ground tripod or vehicle mount.

Training and Doctrine Command (TRADOC) – US Army organization responsible for the Army's training programs and development of service doctrine.

Warrant Officer – Specialty or technical officer appointed by warrant.

Weapons Company – Infantry company responsible for the employment of machine guns and other heavy weapons.

## Bibliography

- 75th Ranger Regiment. "Ranger Assessment & Selection Program." *US Army, 75th Ranger Regiment*. Published July 23, 2015. <http://www.goarmy.com/ranger/training/rasp.html>.
- American Psychological Association. "Think Again: Men and Women Share Cognitive Skills." *American Psychological Association*. Published August, 2014. <http://www.apa.org/action/resources/research-in-action/share.aspx>.
- Baker, Kevin. "The Case for the Draft." *American Heritage* 54, no. 3 (June 2003): 16. <http://search.proquest.com.lomc.idm.oclc.org/docview/202706922?accountid=14746>.
- Binkin, Martin, and Shirley J. Bach. *Women and the Military*. Washington, DC: Brookings Institution, 1977.
- Blankenship, Janie. "Draftees: Invaluable Contributors to the Nation's Defense." *VFW, Veterans of Foreign Wars Magazine* 96, no. 5 (January 2009), 14-15. <http://search.proquest.com.lomc.idm.oclc.org/docview/204888109?accountid=14746>.
- Blum, Michael. "Women Increasingly Join the Fight in Israel's Army." *The Times of Israel*. Published November 20, 2016. <http://www.timesofisrael.com/women-increasingly-join-the-fight-in-israels-army/>.
- Chairman of the Joint Chiefs of Staff. *Joint Operating Environment 2035*. Washington, DC: Joint Chiefs of Staff, July 14, 2016. [http://www.dtic.mil/doctrine/concepts/joe/joe\\_2035\\_july16.pdf](http://www.dtic.mil/doctrine/concepts/joe/joe_2035_july16.pdf).
- Chief of Staff of the Army. *Accessions Occupational Physical Assessment Test (OPAT) Implementation*. HQDA EXORD 202-16, June 16, 2016.
- Chief of Staff of the Army. *US Army Implementation Plan 2016-01 (Army Gender Integration)*. HQDA EXORD 097-16, March 9, 2016.
- Commandant of the Marine Corps. *Fragmentary Order 4 to Marine Corps Force Integration Campaign Plan*. FRAGO 4 (Implementation), December 16, 2015.
- Commanding General, Marine Corps Combat Development Command. *Changes to the Physical Fitness Test, Combat Fitness Test, and Body Composition Program: Advisory I-17*. MARADMIN 670/16, December 20, 2016. <http://www.marines.mil/News/Messages/Messages-Display/Article/1036121/changes-to-the-physical-fitness-test-combat-fitness-test-and-body-composition-p/>.
- DeBruyne, Nese F., and Anne Leland. *American War and Military Operations Casualties: Lists and Statistics*. CRS Report for Congress RL32492. Washington, DC: Congressional Research Service, January 2, 2015. <https://fas.org/sgp/crs/natsec/RL32492.pdf>.

- Demirjian, Karoun. "Are Women Headed for the Draft? Support for the Idea Grows in Congress." *Washington Post*, April 28, 2016. [https://www.washingtonpost.com/news/powerpost/wp/2016/04/28/women-could-be-headed-for-the-draft-after-house-committee-vote/?utm\\_term=.d8ef606184cb](https://www.washingtonpost.com/news/powerpost/wp/2016/04/28/women-could-be-headed-for-the-draft-after-house-committee-vote/?utm_term=.d8ef606184cb).
- Department of Veterans Affairs. *America's Wars*. Washington, DC: Department of Veterans Affairs, May 2016. [https://www.va.gov/opa/publications/factsheets/fs\\_american\\_wars.pdf](https://www.va.gov/opa/publications/factsheets/fs_american_wars.pdf).
- Erwin, Stephanie. "The Veil of Kevlar: An Analysis of the Female Engagement Teams in Afghanistan." Master's thesis, Naval Postgraduate School, March 2012. <http://www.dtic.mil/dtic/tr/fulltext/u2/a560637.pdf>.
- Fox, Tsivya. "Israel's Cutting Edge Co-Ed Combat Battalions." *Breaking Israel News*. Published July 14, 2016. <https://www.breakingisraelnews.com/71838/israels-cutting-edge-co-ed-combat-battalions/#V84KAdY2kYy4dXLQ.97>.
- Gross, Judah Ari. "New Combat Positions For Women in the IDF, Same Old Obstacles." *The Times of Israel*. Published March 13, 2016. <http://www.timesofisrael.com/new-combat-positions-for-women-in-the-idf-same-old-obstacles/>.
- Gross, Judah Ari. "On Egypt Border, Mixed-Gender Unit Fights Old Ideas and New Foes." *The Times of Israel*. Published October 30, 2016. <http://www.timesofisrael.com/on-egypt-border-mixed-gender-troops-fight-old-ideas-and-new-foes/>.
- Halcli, Kassia. "Would Trump's defense secretary push women back out of combat jobs?" *PBS Newshour*. Published December 6, 2016. <http://www.pbs.org/newshour/updates/trumps-defense-secretary-push-women-back-combat/>.
- Headquarters, Department of the US Army. *Army Demographics, FY15 Army Profile*. Washington, DC: Headquarters, Department of the US Army, September 30, 2015. <http://www.armygl.army.mil/hr/docs/demographics/BlueFinalFY15APR.pdf>.
- Headquarters, Department of the US Army. *Army Pocket Physical Training Guide*. Washington, DC: Headquarters, Department of the US Army, January 2011. [https://www.goarmy.com/content/dam/goarmy/downloaded\\_assets/pt\\_guide/pocket-pt-guide.pdf](https://www.goarmy.com/content/dam/goarmy/downloaded_assets/pt_guide/pocket-pt-guide.pdf).
- Headquarters, Department of the US Army. *The Infantry Battalion*. Field Manual 3-21.20. Washington, DC: Headquarters, Department of the US Army, December 2006.
- Headquarters, Department of the US Army. *Field Maintenance, 60-mm Mortars M2 and M19; 60-mm Mortar Mount M5; 60-mm Mortar Baseplate M1; 81-mm Mortars M1 and M29; and 81-mm Mortar and Mounts M3, M23A1, M23A2, and M23A3*. Technical Manual 9-3071-1. Washington, DC: Headquarters, Department of the US Army, January 1967.

- Headquarters US Marine Corps. *Marine Corps Supplement to the DOD Dictionary of Military and Associated Terms*. Marine Corps Reference Publication 5-12C. Washington, DC: Headquarters US Marine Corps, November 16, 2011.
- Headquarters US Marine Corps. *Organization of the United States Marine Corps*. Marine Corps Reference Publication 5-12D. Washington, DC: Headquarters US Marine Corps, August 26, 2015.
- Headquarters US Marine Corps. *Infantry Company Operations*. Marine Corps Warfighting Publication 3-11.1. Washington, DC: Headquarters US Marine Corps, October 6, 2014.
- Headquarters US Marine Corps. *Total Force Structure Management System: M11110 1/1 1st Marine Division, Fiscal Year 2016*. Washington, DC: Headquarters US Marine Corps, October 1, 2016.
- Julian, Hana Levi. "Lions of Jordan Battalion Guard Israel's Jordan Valley." *The Jewish Press*. Published August 5, 2015. <http://www.jewishpress.com/news/breaking-news/lions-of-jordan-battalion-guard-israels-jordan-valley/2015/08/05/>.
- Kreidberg, Marvin A., and Merton G. Henry. *History of Military Mobilization in the United States Army: 1775-1945*. Department of the Army Pamphlet No 20-212. Washington, DC: Headquarters, Department of the US Army, November 30, 1955.
- Lerwill, Leonard L. *The Personnel Replacement System in the United States Army*. Department of the Army Pamphlet No 20-211. Washington, DC: Headquarters, Department of the US Army, August 30, 1954.
- Levine, Neil. *Conflict Assessment Framework v2*. Washington, DC: United States Agency for International Development, June 2012.
- Maltz, Judy. "IDF's Mixed-sex Combat Battalion Lures New Immigrants, Challenge-seekers." *Haaretz*. Published September 3, 2015. <http://www.haaretz.com/israel-news/1.674171>.
- McDaniel, Joe, Richard J. Skandis, and Scott W. Madole. *Weight Lift Capabilities of Air Force Basic Trainees*, Wright-Patterson AFB, OH: Air Force Aerospace Medical Research Laboratory, May, 1983. <http://www.dtic.mil/dtic/tr/fulltext/u2/a129543.pdf>.
- McMichael, Scott R. *A Historical Perspective on Light Infantry*, Combat Studies Institute Research Survey (Fort Leavenworth, KS: US Army Command and General Staff College, 1951), xi-xii.
- McNulty, Andrew. *Adaptability Study Update*. Staff Study, Deputy Commandant, Combat Development and Integration, February 2015.
- Military Selective Service Act. US Code 50 (2012) § 3801. <http://legcounsel.house.gov/Comps/Military%20Selective%20Service%20Act.pdf>.

- National Coalition for Men v. Selective Service System. US Dist. Calif. (2013).  
[https://www.fpparchive.org/media/documents/us\\_military/Lawsuit%20of%20National%20Coalition%20for%20Men%20and%20James%20Lesmeister\\_Mark%20E.%20Angelucci\\_April%204,%202013\\_Law%20office%20of%20Marc.%20E.%20Angleucci.pdf](https://www.fpparchive.org/media/documents/us_military/Lawsuit%20of%20National%20Coalition%20for%20Men%20and%20James%20Lesmeister_Mark%20E.%20Angelucci_April%204,%202013_Law%20office%20of%20Marc.%20E.%20Angleucci.pdf).
- National Coalition for Men v. Selective Service System. No. 13-56690, 9th Cir. (2016).  
<http://law.justia.com/cases/federal/appellate-courts/ca9/13-56690/13-56690-2016-02-19.html>.
- Naval Research Advisory Committee (NRAC). *Human Performance Effects*. Staff Study, Office of Naval Research, 2007.
- Neiberg, Michael S. Review of *The "Good War" in American Memory*, by John Bodnar. *Journal of Social History* 45, no. 3 (2012): 870-872.
- Noy, Becca. "Get To Know the IDF Infantry Corps Brigades: Golani, Givati, Kfir, Nahal, Tzanchanim." *Jerusalem Online*. Published January 8, 2017.  
<http://www.jerusalemonline.com/news/politics-and-military/military/get-to-know-the-idf-infantry-corps-brigades-25818>.
- Rostker, Bernard. *I Want You! The Evolution of the All-Volunteer Force*. Santa Monica, CA: RAND Corporation, 2006.
- Rostker v. Goldberg*. 453 U.S. 57 (1981).
- Schaefer, Agnes Gereben, Jennie W. Wenger, Jennifer Kavanagh, Jonathan P. Wong, Gillian S. Oak, Thomas E. Trail, and Todd Nichols. *Implications of Integrating Women into the Marine Corps Infantry*. Washington, DC: RAND Corporation, 2015.
- Schogol, Jeff. "New in 2017: Future of Marines' gender integration plan uncertain." *Marine Corps Times*. Published December 29, 2016.  
<https://www.marinecorpstimes.com/articles/women-in-marine-combat-jobs>.
- Schumm, Laura. "Food Rationing in Wartime America." *History.com*. Published 2014.  
<http://www.history.com/news/hungry-history/food-rationing-in-wartime-america>.
- Segal, David R., and Mady Wechsler Segal. "U.S. Military's Reliance on the Reserves." *Population Reference Bureau*. Accessed December 2016.  
<http://www.prb.org/Publications/Articles/2005/USMilitarysRelianceontheReserves.aspx>.
- Selective Service System. "Background of Selective Service." *Selective Service System*. Published 2016. Accessed December 2016. <https://www.sss.gov/About/History-And-Records/Background-Of-Selective-Service>.

- Selective Service System. "Induction Statistics." *Selective Service System*. Published 2016. Accessed December 2016. <https://www.sss.gov/About/History-And-Records/Induction-Statistics>.
- Shane, Leo. "Congress Drops Plans to Make Women Register for the Draft." *Military Times*. Published November 29, 2016, <http://www.militarytimes.com/articles/ndaa-women-draft-dropped>.
- Sisk, Richard. "Mattis Pick Could See Senate Clash on Women in Combat, PTSD." *Military.com*. Published December 1, 2016. <http://www.military.com/daily-news/2016/12/01/mattis-pick-could-see-senate-clash-on-women-in-combat-ptsd.html>.
- Szayna, Thomas S., Eric V. Larson, Angela O'Mahony, Sean Robson, Agnes Gereben Schaefer, Miriam Matthews, J. Michael Polich, Lynsay Ayer, Derek Eaton, William Marcellino, Lisa Miyashiro, Marek Posard, James Syme, Zev Winkelman, Cameron Wright, Megan Zander Cotugno, and William Welser IV. *Considerations for Integration of Women into Closed Occupations in the US Special Operations Forces*. Santa Monica, CA: RAND Corporation, May 2015.
- The National World War II Museum. "By the Numbers: The US Military." *The National WWII Museum*. Accessed December 2016. <http://www.nationalww2museum.org/learn/education/for-students/ww2-history/ww2-by-the-numbers/us-military.html>.
- US Army Maneuver Center of Excellence. "BAC Entrance Requirements." *US Army Maneuver Center of Excellence*. Published November 29, 2016. <http://www.benning.army.mil/infantry/rtb/1-507th/airborne/entrancereq.html>
- US Army Maneuver Center of Excellence. *Maneuver Center of Excellence Supplement Manual 3-90 Force Structure Reference Data*. Fort Benning, GA: Maneuver Center of Excellence, October 2016.
- US Army Maneuver Center of Excellence. "Ranger School Preparation." *US Army Maneuver Center of Excellence*. Published September 19, 2016. <http://www.benning.army.mil/infantry/rtb/content/PDF/Ranger%20School%20Prep%201%202.pdf>.
- US Army Recruiting Command. *2015-2016 Pocket Recruiter Guide*. Fort Knox, KY: US Army Recruiting Command, 2015. <http://www.usarec.army.mil/hq/apa/download/PRG15-16.pdf>.
- US Army Special Operations Recruiting Battalion. "Qualifications." *Special Operations Recruiting Battalion (Airborne)*. Published 2016. [http://www.sorbrecruiting.com/SF\\_Qualifications.htm](http://www.sorbrecruiting.com/SF_Qualifications.htm).

US Army Training and Doctrine Command. *Institutional Leader Training and Education*. TRADOC Regulation 350-10, August 12, 2002.

US Department of Defense. *Medical Standards for Appointment, Enlistment, or Induction in the Military Services*. Instruction 6130.03 w/CH1, April 28, 2010.

US Department of Defense. *Personnel Procurement: Military Entrance Processing Station (MEPS)*. Army Regulation 601-270, OPNAVINST 1100.4C CH-2, AFI 36-2003\_IP, MCO 1100.75F, COMDTINST M 1100.2E, September 13, 2011.

US Naval Academy. "Marine Selection." *United States Naval Academy*. Accessed January 1, 2017. <https://www.usna.edu/USMC/Selection.php>.

Wilmore, J.H., "Alterations in Strength, Body Composition and Anthropometric Measurements Consequent to a 10-week Weight Training Program." *Medicine and Science in Sports F*, no. 2 (1974): 133-138.

Women In International Security Combat Integration Initiative. *Combat Integration Handbooks: A Leader's Guide to Success*. Washington, DC: Women In International Security Global, September 2016.

THIS PAGE INTENTIONALLY LEFT BLANK