

DECLASSIFIED

Report No. R-2184

LIBRARY  
NAVAL RESEARCH LABORATORY

NRL-54

FR-2184

REPORT NO. R-2184

DATE 4 November 1943

DECLASSIFIED by NRL Contract  
Declassification Team

Date: 26 Jul 2016

SUBJECT

Reviewer's name(s): A. THOMPSON,  
P. HANNA

Declassification authority: NAVY DECLASS  
MANUAL 11 DEC 2012, 04 SERIES  
08 SERIES, 12 SERIES

Japanese Radar Equipment C.E.E. No. 3088 Captured on Attu

DECLASSIFIED: By authority of  
5000A January 1958  
Entered by: E. Bliss Code 2027

DISTRIBUTION STATEMENT A APPLIES  
Further distribution authorized by  
UNLIMITED only.

NAVAL RESEARCH LABORATORY  
BELLEVUE, D. C.

4 November 1943

NRL Report No. R-2184  
Problem S148.3R-S

NAVAL RESEARCH LABORATORY

*[Redacted text]*

Navy Department  
Report on  
Japanese Radar Equipment

C.E.E. No. 3088

Captured on Attu

Naval Research Laboratory

Anacostia Station

Washington, D.C.

FR-2184

No. of Pages: Text: 11 Plates: 22 Appendix: 3

Authorization: BuShips ltr S-S67-5(924-9) S-920-05991 to NRL dated 21 September 1943.

Prepared by: W.F. Main, Jr.  
W.F. Main, Jr., Contract Employee

L.L. Bonham  
L.L. Bonham, Contract Employee

Submitted by: R.C. Guthrie  
R.C. Guthrie, Head of Search Radar Section

Reviewed by: A. Hoyt Taylor  
A. Hoyt Taylor, Supt. of Radio Div.

Approved by: A.H. VanKeuren  
A.H. VanKeuren, Rear Admiral, U.S.N.  
Director.

- Distribution:
- Cominch Readiness (1)
  - VCNO, Op-16-Z (3)
  - VCNO, Op-20S-4 (1)
  - CNO, Air Info. Div. (1)
  - BuShips, Code 920 (1)
  - BuShips, Code 910 (1)
  - BuAero, Code Aer-E-3144 (1)
  - Dissemination Unit, MIS (4)
  - OEW, Liaison Officer (1)
  - BAD (2)
  - Royal Air Force Delegation (1)
  - British Army Staff (1)

- Joint Intelligence Committee (1)
- Australian Air Force Delegation (1)

LIBRARY  
NAVAL RESEARCH LABORATORY

DECLASSIFIED

Table of Contents

|   | <u>Page</u> |
|---|-------------|
| 1. Abstract . . . . .   | 1           |
| 2. Introduction . . . . .   | 1           |
| 3. Description of Units and Comparison with Guadalcanal Radar . . . . . | 3           |
| 3-1 Transmitter . . . . .   | 3           |
| 3-2 Receiver . . . . .  | 5           |
| 3-3 Synchronization Unit . . . . .                                      | 5           |
| 3-4 Main Indicator Unit . . . . .                                       | 6           |
| 3-5 Monitor Oscilloscope . . . . .                                      | 7           |
| 3-6 Wave Meter . . . . .  | 7           |
| 3-7 Synchro Motors and Generators . . . . .                             | 8           |
| 3-8 Antenna . . . . .   | 10          |
| 3-9 Voltage Regulator . . . . .   | 10          |
| 4. Conclusions . . . . .  | 11          |

|   |          |
|---|----------|
| Photograph of System . . . . .                      | Plate 1  |
| Block Diagram of System . . . . .                   | Plate 2  |
| Photograph of r.f. Section of Transmitter . . . . . | Plate 3  |
| Transmitter Wiring Diagram . . . . .                | Plate 4  |
| Receiver Wiring Diagram . . . . .                   | Plate 5  |
| Receiver Block Diagram - Japanese . . . . .         | Plate 6  |
| Receiver Block Diagram . . . . .                    | Plate 7  |
| Receiver Parts List . . . . .                       | Plate 8  |
| Receiver Power Supply . . . . .                     | Plate 9  |
| Synchronizing Unit . . . . .                        | Plate 10 |
| Block Diagram of Synchronizing Unit . . . . .       | Plate 11 |
| Main Indicator Wiring Diagram . . . . .             | Plate 12 |
| Monitor Scope Wiring Diagram . . . . .              | Plate 13 |
| Wave Meter Wiring Diagram . . . . .                 | Plate 14 |
| Wave Meter Power Supply Wiring Diagram . . . . .    | Plate 15 |
| Photograph of Wave Meter . . . . .                  | Plate 16 |
| Voltage Regulator Diagram . . . . .                 | Plate 17 |
| Photograph of Remote Indicators . . . . .           | Plate 18 |
| Photograph of Synchro Motors . . . . .              | Plate 19 |
| Front View of Control Box . . . . .                 | Plate 20 |
| Rear View of Control Box . . . . .                  | Plate 21 |
| Photograph of Tube Types . . . . .                  | Plate 22 |

|   |              |
|---|--------------|
| Translation of Transmitter Parts List . . . . . | Appendix I   |
| Translation of Receiver Parts List . . . . .    | Appendix II  |
| Translation of Operating Instructions . . . . . | Appendix III |

DECLASSIFIED

1. ABSTRACT.

1-1. On 22 July 1943, a shipment of Japanese radar equipment, captured on Attu Island by the U.S. Army, was received at this laboratory. This equipment consisted of two essentially complete radar systems: one, serial No. 158, manufactured in November 1942, and the second, serial No. 161, manufactured in December 1942.

1-2. Both of these systems were set up and operated at this laboratory, using an antenna constructed for the testing of similar Japanese equipment captured on Guadalcanal. Operating characteristics of the Attu radar were found to be similar to the Guadalcanal radar, and are listed below:

|                      |                                    |
|----------------------|------------------------------------|
| Frequency range:     | 92-105 mc.                         |
| Pulse Power output:  | Nominal: 5 kw, Measured: 2.7 kw.   |
| Repetition rate:     | 1000 cps.                          |
| Pulse width:         | 15-17 microseconds.                |
| A.C. Input:          | 220 v., 3 phase, 50-60 cycles.     |
| A.C. Input Power:    | 4 kw (approx.).                    |
| Range (Total sweep)  | 150 km (82 miles, nautical).       |
| Calibration markers: | Every 10 km (5.5 miles, nautical). |

The only difference between the more recently captured gear and that captured earlier on Guadalcanal are improvements which make for easier servicing and greater dependability.

1-3. Since the Attu equipment is identical in performance to the Guadalcanal radar, similar forms of countermeasures would be effective against the two types. Countermeasures effective against the Guadalcanal radar are described in the report of reference (c) and in the letter of reference (j).

2. INTRODUCTION.

2-1. On 30 May 1943, the U.S. Army took over Chichagof Bay from the Japanese and found the partially completed installations of two separate radars. These units were examined by the Signal Corps and sent to the United States for further study, as described in the report of reference (b). On 22 July 1943, the shipment of material from Attu was received at this laboratory. In the shipment were two essentially complete radar systems. One had the serial No. 158 and was manufactured in November 1942, while the other had the serial No. 161, and was manufactured in December 1942. It is of interest to note that the Guadalcanal equipment bore serial Nos. 9, 29, and 35, and were manufactured in January, February, and March, 1942. Following preliminary inspection and inventory of the material shipped from Attu, a letter report was written to the Bureau of Ships on 13 August 1943 (Reference (d)).

2-2. Tests of this equipment were authorized by Bureau of Ships letter of reference (a), assigning problem No. S-148.3R-S. Other references pertaining to this problem are listed as references (b) through (j).

- Ref. (a) BuShips ltr S-S67-5(924-9), S-920-05991 to NRL dated 21 Sept. 1943.
- (b) "Report on Japanese Radar Captured on Attu", 11th Air Force Operations Analysis Section, dated 1 July 1943.
- (c) NRL Report on Japanese Radar Equipment C.E.E. No. 211, Captured on Guadalcanal, Report No. R-2183, dated November 1943.
- (d) NRL ltr S-S67/5EF37(378) Serial No. 1629 to BuShips dated 13 Aug. 1943.
- (e) NRL ltr S-S67/36(370) Serial No. 1116 to BuShips dated 2 Feb. 1943.
- (f) NRL ltr S-S67-5/RCM, Serial No. 1836 to BuShips dated 24 Sept. 1943.
- (g) VCNO ltr Op-20-S-4/dea, (SC) S67-5/EF37 Serial No. 01128820 to NRL with Enc. (A), (B), and (C), dated 25 July 1943.
- (h) ComNoPac secret ltr to VCNO, Serial No. 0509 and Enc. (A), (B), (C), and (D) thereto, dated 11 July 1943.
- (i) "Report on Japanese Kiska Radars", 11th Air Force Operations Analysis Section, dated 12 Sept. 1943.
- (j) NRL Secret ltr S-S67-5/EF37(378), Serial 2039 to BuShips, dated November 1943, Subj: Radar Countermeasures - Tests against Japanese Radar, C.E.E. No. 211.

2-3. On 3 August 1943, work was started in setting up the equipment. Circuits were traced, and the equipment was cleaned up. On 17 August 1943, an Army Signal Corps engineer arrived to assist in setting up and testing this equipment. Both systems were placed in operation and measurements of the significant characteristics were made. Following this, on 21 September 1943, the system serial No. 161 was removed to Florosa Field, Florida for further tests by the U.S. Army. The serial No. 150 equipment was retained at this laboratory.

2-4. Information was desired as to whether the Attu gear was more or less susceptible to countermeasures than that captured at Guadalcanal. The important features of radar equipment examined from this viewpoint were: pulse power output, repetition rate, pulse length, receiver characteristics and antenna characteristics. These features of the system were therefore examined and compared with those of the Guadalcanal radar. Since the characteristics of this previous model have been discussed fully in the report of reference (c), and since so many features of the two systems are identical,

this report will not attempt to discuss every detail in the operation, but instead it will note the differences between the two models. As these two models were manufactured approximately one year apart, a comparison between the two systems is significant in that it may indicate the progress made by Japan in the development of radar gear during 1942.

### 3. DESCRIPTION OF UNITS AND COMPARISON WITH GUADALCANAL RADAR.

In order to make a comparison between the Guadalcanal and the Attu radars, each of the component units will be discussed separately. The units of the Attu radar are as follows:

- (a) Transmitter.
- (b) Receiver.
- (c) Synchronizing Unit.
- (d) Indicator Oscilloscope.
- (e) Monitor Oscilloscope.
- (f) Wave Meter.
- (g) SynchroIndicators.
- (h) Antenna.
- (i) Voltage Regulator.

Each will be discussed and compared with the similar unit of the Guadalcanal radar.

3-1. Transmitter. Although the Attu transmitter (Plate 4) shows considerable improvement over the Guadalcanal transmitter with respect to the physical construction and some improvement in circuit design, the pulse power, pulse width, and repetition rate are unchanged (see paragraph 1-2). Most of the improvements have been made for the purpose of making the units more reliable. Appendix I is a translation of the parts lists given with the circuit diagram of the transmitter and modulator (Plate 4).

3-1-1. Like the Guadalcanal radar, the master oscillator is grid-keyed. The high "Q" tank in the plate circuit of the previous model has now been replaced by a balanced transmission line tuned circuit similar to the arrangement used in the power amplifier. (Plate 3 is a photograph of the R.F. section of the transmitter). The oscillator grids are now tuned by a shorted transmission line, but the filaments are tuned in the same manner as previously. The final amplifier is identical to the one of the previous unit. As before, both stages are biased beyond cut-off and the grid-keyed oscillator drives the amplifier.

3-1-2. The keyer, or modulator, is now a plug-in unit to the transmitter, and consists of three stages. The first stage is a pentode amplifier using a UZ-42 tube, which is transformer coupled to a gas tetrode tube type XB-767-A. The electrical characteristics of this tube (see Plate 22, tube #4) are closely similar to the American

type 2050 but it has a 6-prong base instead of the octal type. This stage drives a triode power amplifier employing a TB-506-C (a large transmitting type tube of approximately 100 watt size which is also shown in Plate 22, tube #2). The final stage of the Guadalcanal keyer used a thyratron, which was not satisfactory, as the Japanese tube had a relatively short life. This was indicated by the fact that a reserve tube was built in the unit, to be switched in the circuit when a failure occurred. The revised circuit has proved more reliable than the previous one.

3-1-3. The transmitter power supply is changed considerably from the one in the Guadalcanal radar. The input is three-phase, 220 volts, 50-60 cycles as before, but the three phase induction voltage regulator, formerly built into the transmitter, is now a separate unit. The rectifiers are now single-phase full wave, and employ high-vacuum tubes type K-251 (shown as tube #1 in Plate 22) instead of the mercury vapor tubes used before. A choke coil, in series with the primary of the high voltage transformer of the amplifier plate voltage supply, reduces the output voltage to prevent damage to tubes and meters during tuning and adjustment. This coil is shorted out when the full operating voltage is desired. No continuous adjustment of plate voltage is possible. There is no adjustment for the plate voltage of the oscillator.

3-1-4. One interesting feature has been added to this transmitter that was not on the previous equipment. There is a protective spark gap (part #6 and 22 in Plate 4, item #3 in Plate 22) from the grids of the transmitting tubes to ground. One electrode of the gap is a small pool of mercury. The purpose of this gap is evidently to protect the grid circuit meters in case of flashover within the tube. Experience with similar devices in American circuits shows that the protective device must be placed near the point of flashover in order to give adequate protection. These gaps are some distance from the grid leads, as they are mounted just inside and to the lower right of the front panel of the transmitter, as shown in Plate 1. Instead of only one gap being used, three identical gap tubes are connected in series. This fact indicates that they were originally intended for lower voltage circuits, hence three were connected in series for the desired gap spacing. However, the gaps appear to be effective.

3-1-5. The operating voltages and currents for the oscillator and amplifier are as follows:

|                | <u>Oscillator</u> | <u>Amplifier</u> |
|----------------|-------------------|------------------|
| Plate Voltage: | 3300 v.           | 5200 v.          |
| Plate Current: | 40 ma.            | 55 ma.           |
| Grid Voltage:  | 320 v.            | 400 v.           |
| Grid Current:  | 4 ma.             | 4.5 ma.          |

(When the plate voltage switch is in the "Adjust" position, the plate voltage of the amplifier is approximately 3.5 kv.)

3-2. Receiver. Two types of receivers were included with the radar equipment captured on Guadalcanal. The smaller was evidently of Japanese design, but the larger was believed by many observers at this laboratory to be of German design. With the Attu equipment only one type of receiver was found (Plates 5, 6, 7, 8, and 9); it was identical to the "German" type receiver mentioned above. Copies of the original Japanese wiring diagram, block diagram and receiver parts list are Plates 5, 6 and 8 respectively. Appendix II is a translation of the receiver parts list (Plate 8).

3-2-1. The receiver is a double superheterodyne type with a tuning range of 89 to 115 mc. The first intermediate frequency is 21.55 mc; the second 3.5 mc. The characteristics of this receiver are described fully in the report of reference (c).

3-3. Synchronization Unit. The circuit of the synchronization unit (Plates 10 and 11) of the Attu radar is fundamentally the same as that used in the system captured at Guadalcanal. A 15 kc sine wave is generated and divided to a 1 kc sawtooth; the sawtooth is used to form a pulse to key the transmitter, form the sweep, provide return blanking, and provide a pulse to synchronize the monitor oscilloscope. The 15 kc sine wave is also squared, differentiated, and amplified to furnish pulse markers for the main indicator oscilloscope.

3-3-1. The first departure from the design of the Guadalcanal radar appears in the method of frequency division. While the division from 15 kc to 1 kc was made in one step in the earlier captured radar, this division is made in two steps in the Attu equipment. The 15 kc sine wave is divided by V2 and V3. The output of this circuit is a 3 kc sawtooth having a 15 kc ripple; this sawtooth is divided to a 1 kc sawtooth having a 3 kc ripple. The outputs of the 3 kc and 1 kc dividers are fed to banana plug jacks on the front panel. The input from the monitor oscilloscope is plugged into these to make possible rapid localization of circuit failure in the synchronization unit. These jacks are marked 15 kc, 1/5 (3 kc), and 1/3 (1 kc). These markings led to a first impression that the system used more than one pulse repetition rate and indicator range scale, as stated in the letter of reference (d). Actually, as described above, only one repetition rate and one range scale are used.

3-3-2. The 1 kc output which is obtained from the last dividing circuit is fed to a 6D6, a pulse forming oscillator, which generates a pulse for the transmitter keying. By adjusting potentiometers ( $R_A$ ,  $R_B$  and  $R_C$  as shown in Plate 10) in the pulse forming oscillator circuit, the phase of the transmitter keying pulse may be shifted with respect to the sweep forming pulse, thereby placing the transmitter pulse at the start of the sweep and in line with one of the range markers. The transmitter keying pulse is amplified and fed to the modulator unit from a type UX-76 cathode follower.

3-3-3. A 1 kc pulse is fed from the last divider circuit to a 76, V-101. The return blanking and synchronization for the monitor oscilloscope are obtained from the cathode of V-101, while the plate feeds another 76, V-5, for production of the sweep voltage for the main indicator oscilloscope. In the plate circuit of V-5, there is a large inductance, L-101, across which is connected an 0.01 mfd mica condenser, C-104. Tube V-5 is operated at a fairly high bias, and normally very little plate current flows. When the positive pulse is applied to the grid, a large plate current flows and charges up the condenser, C-104 which, after the pulse has passed, discharges slowly through the inductance, forming the sweep. This is a typical sawtooth generator circuit.

3-3-4. The synchronization unit also supplies plate power for the video amplifier in the main indicator oscilloscope. The connections for these leads are referred to as the "D.C. Input" in the discussion of this unit on page 11 of reference (b).

#### 3-4. Main Indicator Unit.

3-4-1. The main indicator unit (Plate 12) contains the final amplifier for the video and an amplifier for the sweep. A pentode type 6302 tube, one of the few that is not a direct copy of an American type, is used in a conventional circuit for the final video amplifier.

3-4-2. The sweep voltage, generated in the synchronization unit, is applied to the grid of a 42-A power pentode by means of a potentiometer which controls the sweep amplitude. This voltage is then transformer coupled to the horizontal plates of the cathode ray tube. The transformer gives the desired balanced sweep voltage output. This system differs from the conventional American circuit which usually employs an extra tube for phase inversion. Since this conventional circuit was used in the Guadalcanal radar, the transformer method must have been considered an improvement. However, the benefits derived by employing this circuit are not apparent since the same results can be obtained by the phase inversion circuit, and the design requirements for a transformer capable of handling the sweep voltage waveform are severe.

3-4-3. The return blanking and marker signals also are generated in the synchronizing unit. The return blanking pulse drives the cathode of the SSE-120-G tube positive with respect to the grid. The markers are applied directly to one of the vertical deflecting plates. The generation of these signals is discussed in paragraph 303.

3-4-4. The main indicator of the Guadalcanal radar consisted of three separate units as described in the report of reference (c). The arrangement of the Attu radar is more compact since only one unit is used. Practically identical results are obtained, however.

3-4-5. One feature appearing on the earlier model has been omitted from the Attu indicator. The Guadalcanal indicator had two methods of presentation. One of these was standard type A presentation. The other showed the echoes as blank places on a wide line sweep, the echo video voltage being applied to the grid of the cathode ray tube, as explained in the report of reference (c). The latter method had no apparent advantage and it has been eliminated from the newer model.

3-5. Monitor Oscilloscope. Although the monitor oscilloscope (Plate 13) is not an integral part of the radar system, it is very useful in checking the pulse signal at various points in the system. This unit employs only one three-inch tube while the Guadalcanal radar monitor scope used four three-inch tubes. The signal is monitored at four different points simultaneously in the latter, while in the Attu system the one oscilloscope is used to monitor the signal at the desired points with convenient plug in jacks. The type SSE-75-G cathode ray tubes of both models are identical and are similar to the American type tube 3AP1.

3-5-1. The monitor oscilloscope is a complete cathode ray oscillograph of inferior quality. It is self-contained, having its own power supply, generating its own sweep, and incorporating one stage of video amplification (a 6D6 pentode). Plate 13 is a schematic diagram of the circuit. The sweep is generated by charging a 0.01 mfd condenser through a high inductance choke. Because of the average bias across C-9, the UY-76 will not conduct for low values of plate voltage. When the plate voltage reaches a certain pre-determined value, however, the tube will start to conduct, and, due to the transformer regeneration, the rise in plate current will be rapid. The pulse of plate current discharges the 0.01 mfd condenser across which the sweep was being generated and simultaneously the grid draws current. The grid pulse is used for the return blanking by applying it to the grid of the cathode ray tube. The 0.01 mfd condenser is now in its original discharged condition and the process repeats itself. In order to synchronize the sweep with the incoming signal, an output from the synchronizing unit is amplified and transformer coupled to the plate and grid of the UY-76.

3-5-2. The four monitor cathode ray tubes of the Guadalcanal radar had a common power supply, causing any adjustment of one to react on the other three. This difficulty has been eliminated by using only one tube. Also, the unit is much more compact than before. Although these changes are improvements over the Guadalcanal monitor, the unit is still inferior to the commercial models of American cathode ray oscilloscopes.

### 3-6. Wave Meter.

3-6-1. The wavemeter (Plates 14, 15 and 16) is an auxiliary unit used in aligning the receiver to the transmitter frequency. This unit was not captured with the Guadalcanal radar although it is mentioned in the captured instruction book. The following paragraph

appears on page 23 of the instruction book (reference (c)), with regard to the tuning of the receiver to the transmitter frequency:

"II When there is no suitable echoing target in the vicinity.

14. Disconnect the transmitter, receiver, and frequency meter to the original condition.

15. Measure the frequency of the transmitter emissions with the frequency meter.

16. Next cut off the modulator voltage, the transmitter voltage and the power, stopping transmitter emission.

17. Change the setting of the frequency meter to receive, then commence reception of the modulated wave transmission of the frequency meter in the receiver. By adjusting the local oscillator tuning condenser and the H.F. tuning condenser you get the point of maximum effect.

18. This completes the tuning of the receiver."

3-6-2. When the send-receive switch in Plate No. 4 is on the "send" position, the received transmitter signal is heterodyned with a local oscillator, which uses a 955 tube. This oscillator is tuned to the transmitter frequency as indicated by the audible beat in the earphones. The switch is then thrown to the "Receive" position and the 955 oscillator is modulated by another oscillator (a 76 tube). This oscillator is used as a signal generator and the output goes to the receiver. The receiver is then tuned for maximum output. The power supply for the wave meter is a separate unit; the circuit diagram is given in Plate 15.

3-7. Synchro Motors and Generators. Of particular interest were the synchro motors found with the equipment. These are shown in the photograph of Plate 19.

3-7-1. Plates 20 and 21 are photographs of a box containing a synchro generator unit. There is a dial calibrated in degrees connected to a gear train extending to a joint just above a hole in the bottom of the box. Below is another dial, calibrated in kilometers, which is connected to a generator-type synchro. The dials both have knobs. In between the two dials, and to the side, is a push button s.p.s.t. switch. The push button, according to the translated nameplate, controls a buzzer, and is assumed to be for signalling when the equipment is "on target". The control boxes have serial numbers 68284 and 68285.

3-7-2. The remote train and range indicator units (Plate 17) calibrated in degrees and kilometers, respectively, each contain a motor-type synchro in a round cast aluminum case. There is a rheostat on the side for controlling brilliance of the three pilot

lights which illuminate the dial, and for switching out the illuminating lights and switching in a light in the terminal box to show that the unit is operating. The units were made by Kure Arsenal in June, 1943 and bear serial numbers 35, 36, 39 and 49.

3-7-3. The Synchro units (Plate 19) are fairly well constructed. They have spiral cuts on the laminations of the rotor, the brushes are dual and independently sprung for positive contact, and the slip rings appear to be gold plated. There is a cast strap bearing retainer, but there is no case to prevent the entrance of dust and other foreign matter. In the generator units both bearings are steel-on-steel, and the other is steel-on-steel with a ball thrust bearing. This latter could not function, however, unless the face of the dial was pointing downward, and in this position it turns least easily, so the bearing is evidently extraneous.

3-7-4. Both the motor and the generator units are stator excited, the rotor having three windings. In both units, there are two separate windings on the stator; in the case of the motor unit, the second winding functions as a step-down transformer from the line to provide power for the illuminating lamps.

3-7-5. Based upon the experimental value obtained from the fact that the bulbs are rated at 15 volts, 50 volts was used as field excitation. With this voltage applied, in several trials, the motor followed within plus or minus  $\frac{1}{2}$  degree.

3-7-6. Specifications for U.S. Navy fire control Synchros require an average static accuracy of 0.2 degree deviation, with a maximum of 0.5 degree deviation. Due to the fact that the dials on the Japanese Synchros cannot be read closer than  $\frac{1}{2}$  degree, no attempt was made to determine whether the average accuracy was better than that value, but it is doubtful that such would be the case. As for physical construction, the Japanese models are far inferior to those of American design. The rotors of the motor units do not turn freely; in fact, there is so much friction, that there is no need for the damping arrangement common to American models. No attempt was made to reduce friction in the generator type Synchros. In one test, a generator type was driven by another; the rotor of the unit under observation turned with the greatest difficulty and did not follow at all.

3-7-7. The master control box is painted khaki and the remote indicator units are painted gray, while the radar equipment is painted black. This cast some doubt as to whether the Synchros were designed for use with the radar. The most conclusive evidence found was that the calibrations on the different units are different. While the radar main indicator oscilloscope and the remote indicator units read maximum range as 150 km (for 360° rotation of the remote indicator pointer) the master control box has 300 km for the 360°.

Since on the latter the range is a multiple of the range reading on the first two, it is possible to use the units as a system. However, this may indicate that the units were not designed for use with the radar as a system, but were pressed into service.

3-8. Antenna. Very little information concerning the antenna used with the Attu radar was received. The writers of the report of reference (b) note the absence of anything resembling a duplexing device, but remark that there may have been one, since a device as small as a spark-gap or gap-tube might easily be overlooked. However, it is to be noted that there definitely was no duplexer in the equipment captured at Guadalcanal, but instead the antenna system consisted of separate arrays (on common mount) for receiving and transmitting. A sufficient quantity of copper rods and insulators were included with the Attu equipment to construct two complete antenna systems. The rods were made of copper tubing  $3/8$ " in diameter and were intended to be supported by the standoff insulators. There were 8 quarter-wave lengths and 16 half-wave lengths of copper rod for each antenna. These numbers correspond exactly to the number of such elements used in the Guadalcanal antenna.

The report of reference (i) describes and includes photographs of the antennas used on Kiska Island. The framework and antenna spacing appear to be identical to that used on Guadalcanal. The report also states that no "transmit-receiver box" or spark gap was found but we may suppose that the Japanese are acquainted with the technique of using the same antenna for both transmission and reception. However, the similarity of the antenna system to that used at Guadalcanal indicates that the two systems may have been identical. The report of reference (c) fully describes the Guadalcanal antenna system.

3-9. Voltage Regulator. The components of the three phase voltage regulator (Plate 17) are almost identical to those used in the Guadalcanal radar. However, instead of being built into the transmitter, the Attu unit is entirely separate. The circuit and operation is that of a conventional three phase induction regulator. This is used to raise or lower the line voltage to the required value. The regulator is turned by a motor which is controlled by a reversing relay. The relay is energized by a contact making voltmeter. The output voltage may be varied somewhat by changing the "relay adjust" resistor shown in Plate No. 17.

3-10. The units (Plate 1) were connected as shown in the block diagram, Plate 2, and the system set in operation.

Measurements made on the equipment were:

|                    |                         |
|--------------------|-------------------------|
| Pulse Power Output | 2.7 kw (Nominally 5 kw) |
| Pulse Width        | 16 microseconds         |
| Repetition Rate    | 1000 cycles per second. |

3-10-1. The average power output was measured by using an incandescent lead lamp with a photo cell and microammeter. The highest value of pulse power obtained was 2.7 kw (pulse length 16 microseconds). The rated nominal pulse power for this equipment is assumed to be the same as for the previous model since the final amplifiers are identical and the pulse length is unchanged. The nominal pulse power given in the Japanese instruction book found on Guadalcanal was 5 kw.

3-10-2. The receiver was carefully examined and compared with the German type receiver captured at Guadalcanal. No differences were found and no anti-jam features had been added.

3-10-3. From an examination of the two systems, serial Nos. 158 and 161, manufactured in November and December of 1942 respectively, it was observed that a few minor circuit changes had been made in the month between their manufacture. The diagram of Plate 10 is that of unit No. 161. Supporting evidence of the fact that there was little or none of the standardization necessary for mass production technique is the fact that covers for particular units are not interchangeable between the two systems.

#### 4. CONCLUSIONS.

4-1. Except for the changes which affect dependability and serviceability in the Attu radar, no significant difference in performance was noted between this gear and that captured at Guadalcanal.

4-2. Therefore, since none of the characteristics which determine effectiveness against countermeasures have been altered in any great sense, countermeasures effective against the Guadalcanal radar would be effective against the Attu radar.

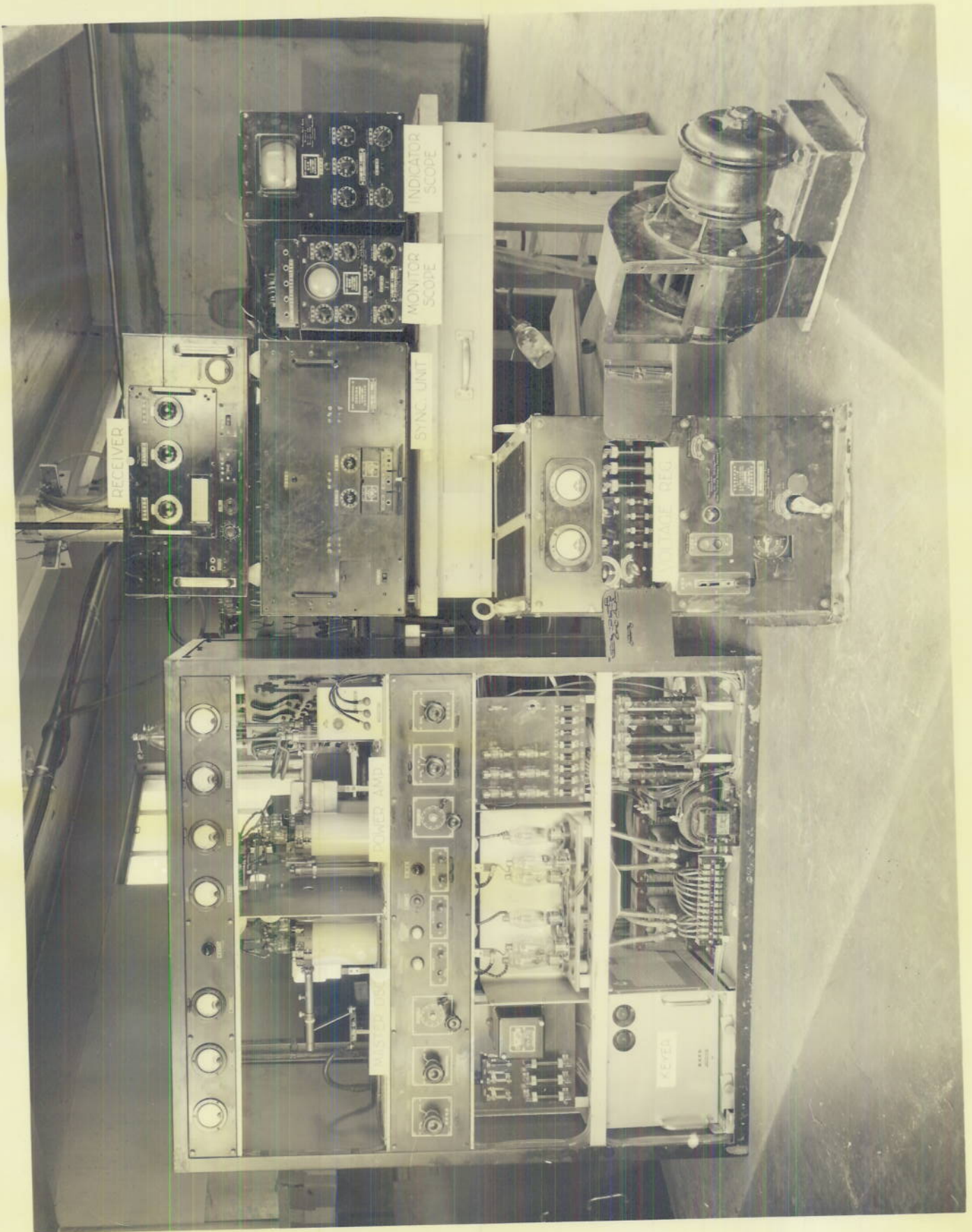

**CONFIDENTIAL**

DECLASSIFIED

PLATE I

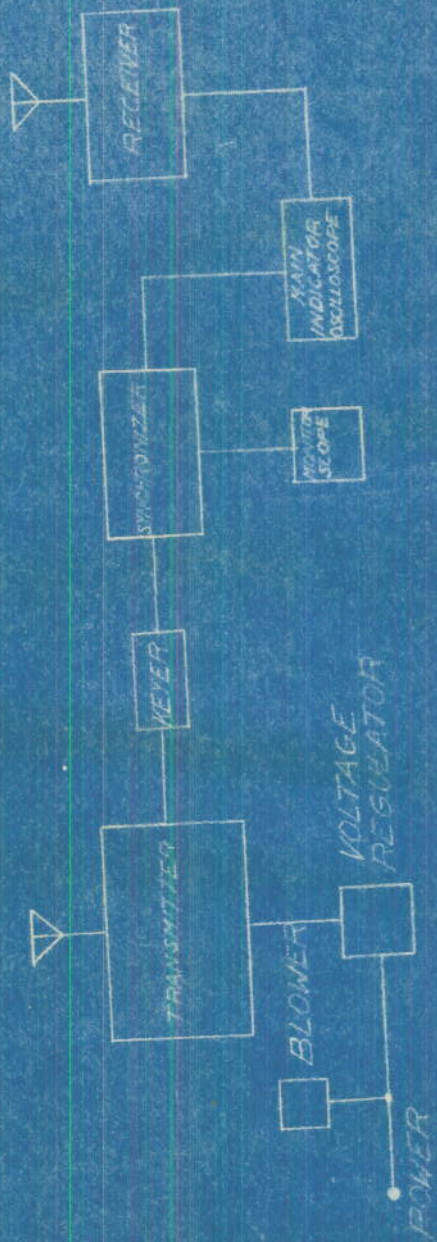

BLOCK DIAGRAM  
AT TU RADAR

DECLASSIFIED

PLATE 2



POWER AMP.

MASTER OSC.

~~CONFIDENTIAL~~

DECLASSIFIED

PLATE 3

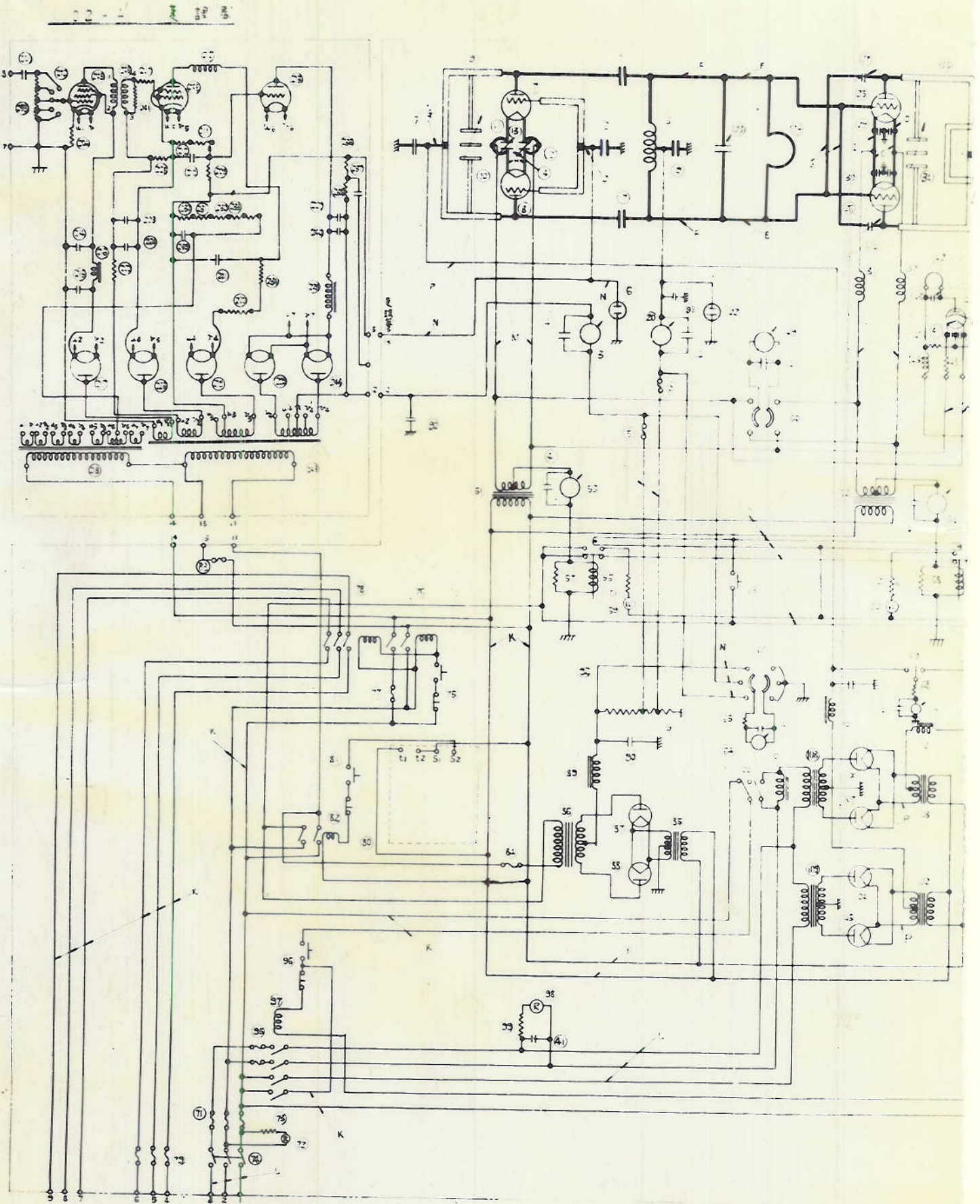
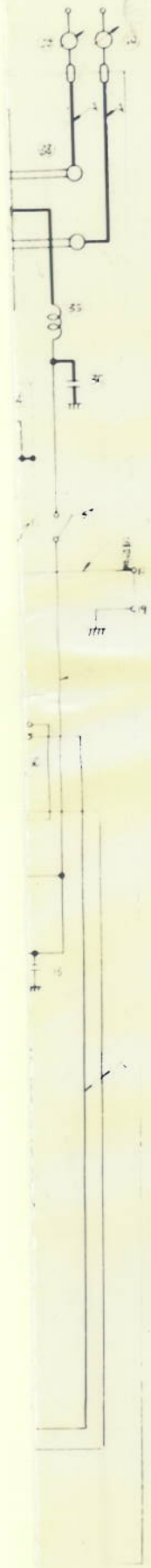

Plate  
4

DECLAS



| 序號 | 名稱    | 數量 | 備註 |
|----|-------|----|----|
| 1  | 行車線軸  |    |    |
| 2  | 行車線電機 |    |    |
| 3  | 行車線電機 |    |    |
| 4  | 行車線電機 |    |    |
| 5  | 行車線電機 |    |    |
| 6  | 行車線電機 |    |    |
| 7  | 行車線電機 |    |    |
| 8  | 行車線電機 |    |    |
| 9  | 行車線電機 |    |    |
| 10 | 行車線電機 |    |    |
| 11 | 行車線電機 |    |    |
| 12 | 行車線電機 |    |    |
| 13 | 行車線電機 |    |    |
| 14 | 行車線電機 |    |    |
| 15 | 行車線電機 |    |    |
| 16 | 行車線電機 |    |    |
| 17 | 行車線電機 |    |    |
| 18 | 行車線電機 |    |    |
| 19 | 行車線電機 |    |    |
| 20 | 行車線電機 |    |    |
| 21 | 行車線電機 |    |    |
| 22 | 行車線電機 |    |    |
| 23 | 行車線電機 |    |    |
| 24 | 行車線電機 |    |    |
| 25 | 行車線電機 |    |    |
| 26 | 行車線電機 |    |    |
| 27 | 行車線電機 |    |    |
| 28 | 行車線電機 |    |    |
| 29 | 行車線電機 |    |    |
| 30 | 行車線電機 |    |    |
| 31 | 行車線電機 |    |    |
| 32 | 行車線電機 |    |    |
| 33 | 行車線電機 |    |    |
| 34 | 行車線電機 |    |    |
| 35 | 行車線電機 |    |    |
| 36 | 行車線電機 |    |    |
| 37 | 行車線電機 |    |    |
| 38 | 行車線電機 |    |    |
| 39 | 行車線電機 |    |    |
| 40 | 行車線電機 |    |    |
| 41 | 行車線電機 |    |    |
| 42 | 行車線電機 |    |    |
| 43 | 行車線電機 |    |    |
| 44 | 行車線電機 |    |    |
| 45 | 行車線電機 |    |    |
| 46 | 行車線電機 |    |    |
| 47 | 行車線電機 |    |    |
| 48 | 行車線電機 |    |    |
| 49 | 行車線電機 |    |    |
| 50 | 行車線電機 |    |    |
| 51 | 行車線電機 |    |    |
| 52 | 行車線電機 |    |    |
| 53 | 行車線電機 |    |    |
| 54 | 行車線電機 |    |    |
| 55 | 行車線電機 |    |    |

| 序號 | 名稱    | 數量 | 備註 |
|----|-------|----|----|
| 56 | 行車線電機 |    |    |
| 57 | 行車線電機 |    |    |
| 58 | 行車線電機 |    |    |
| 59 | 行車線電機 |    |    |
| 60 | 行車線電機 |    |    |
| 61 | 行車線電機 |    |    |
| 62 | 行車線電機 |    |    |
| 63 | 行車線電機 |    |    |
| 64 | 行車線電機 |    |    |
| 65 | 行車線電機 |    |    |
| 66 | 行車線電機 |    |    |
| 67 | 行車線電機 |    |    |
| 68 | 行車線電機 |    |    |
| 69 | 行車線電機 |    |    |
| 70 | 行車線電機 |    |    |
| 71 | 行車線電機 |    |    |
| 72 | 行車線電機 |    |    |
| 73 | 行車線電機 |    |    |
| 74 | 行車線電機 |    |    |
| 75 | 行車線電機 |    |    |
| 76 | 行車線電機 |    |    |
| 77 | 行車線電機 |    |    |
| 78 | 行車線電機 |    |    |
| 79 | 行車線電機 |    |    |
| 80 | 行車線電機 |    |    |
| 81 | 行車線電機 |    |    |
| 82 | 行車線電機 |    |    |
| 83 | 行車線電機 |    |    |
| 84 | 行車線電機 |    |    |
| 85 | 行車線電機 |    |    |

| 序號  | 名稱    | 數量 | 備註 |
|-----|-------|----|----|
| 86  | 行車線電機 |    |    |
| 87  | 行車線電機 |    |    |
| 88  | 行車線電機 |    |    |
| 89  | 行車線電機 |    |    |
| 90  | 行車線電機 |    |    |
| 91  | 行車線電機 |    |    |
| 92  | 行車線電機 |    |    |
| 93  | 行車線電機 |    |    |
| 94  | 行車線電機 |    |    |
| 95  | 行車線電機 |    |    |
| 96  | 行車線電機 |    |    |
| 97  | 行車線電機 |    |    |
| 98  | 行車線電機 |    |    |
| 99  | 行車線電機 |    |    |
| 100 | 行車線電機 |    |    |
| 101 | 行車線電機 |    |    |
| 102 | 行車線電機 |    |    |
| 103 | 行車線電機 |    |    |
| 104 | 行車線電機 |    |    |
| 105 | 行車線電機 |    |    |
| 106 | 行車線電機 |    |    |
| 107 | 行車線電機 |    |    |
| 108 | 行車線電機 |    |    |
| 109 | 行車線電機 |    |    |
| 110 | 行車線電機 |    |    |
| 111 | 行車線電機 |    |    |
| 112 | 行車線電機 |    |    |
| 113 | 行車線電機 |    |    |
| 114 | 行車線電機 |    |    |
| 115 | 行車線電機 |    |    |
| 116 | 行車線電機 |    |    |
| 117 | 行車線電機 |    |    |
| 118 | 行車線電機 |    |    |
| 119 | 行車線電機 |    |    |
| 120 | 行車線電機 |    |    |

SSIFIED

PLATE 4A

1<sup>st</sup> Local Osc.

1<sup>st</sup> Converter

R.F. Amplifier

R.F. Input

2<sup>nd</sup> Local Osc.

2<sup>nd</sup> Converter

2<sup>nd</sup> I.F. - 3.5 mc.

2<sup>nd</sup> I.F. - 3.5 mc.

VIDEO AMPLIFIER

RECEIVER CIRCUIT - JAPANESE RADAR (ATTU - 1943).

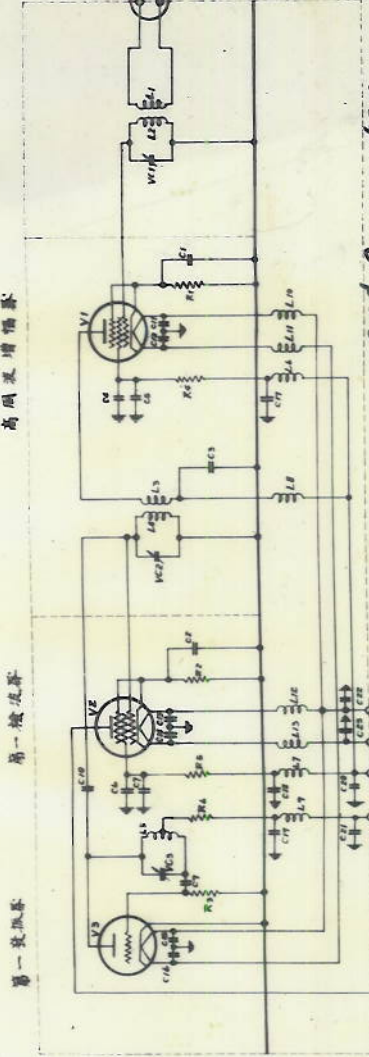

1<sup>st</sup> I.F. 21.55 mc.

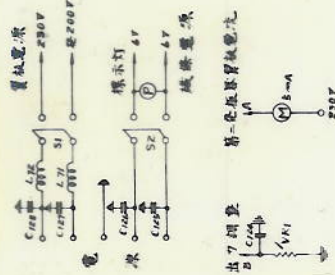
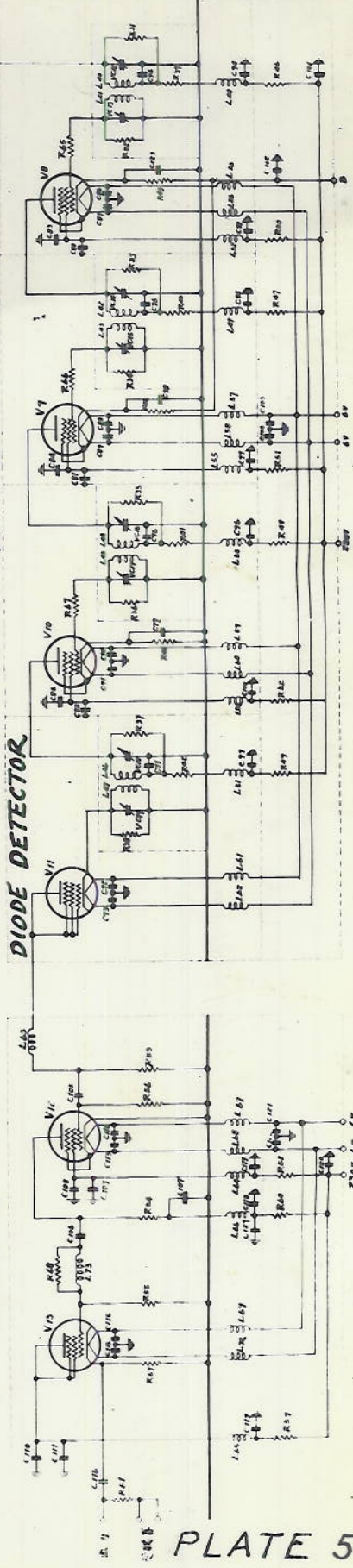
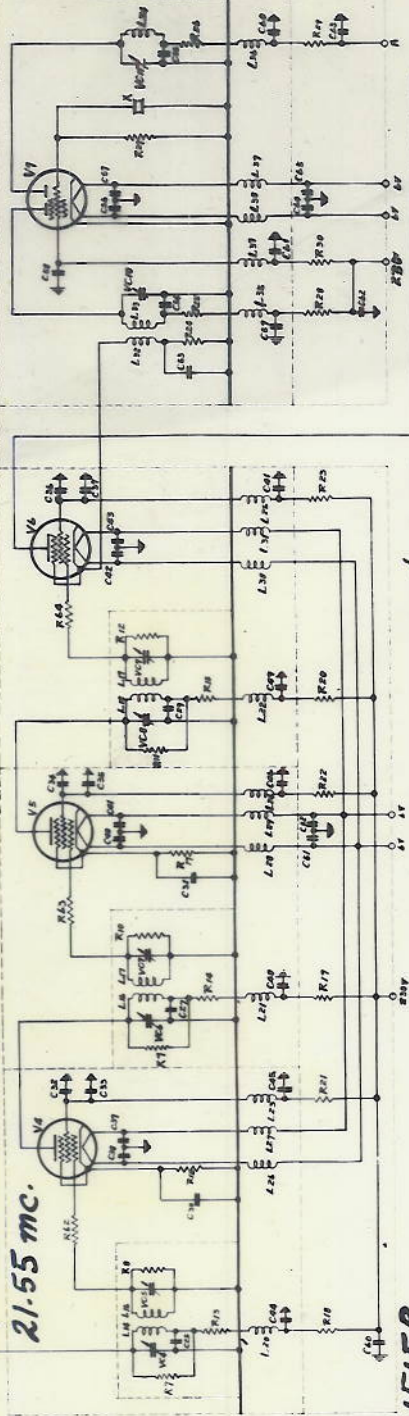

DECLASSIFIED

PLATE 5

**CONFIDENTIAL**

主 體 配 線 圖  
(底面ヨリ見タル圖)  
Bottom View

高周波カソード  
スイッフルド線ノ下ニ  
付テ、導子普通ノ線ノ下ニ  
High Freq. Cathode  
POWER source  
出力調整ノツグ  
output meter

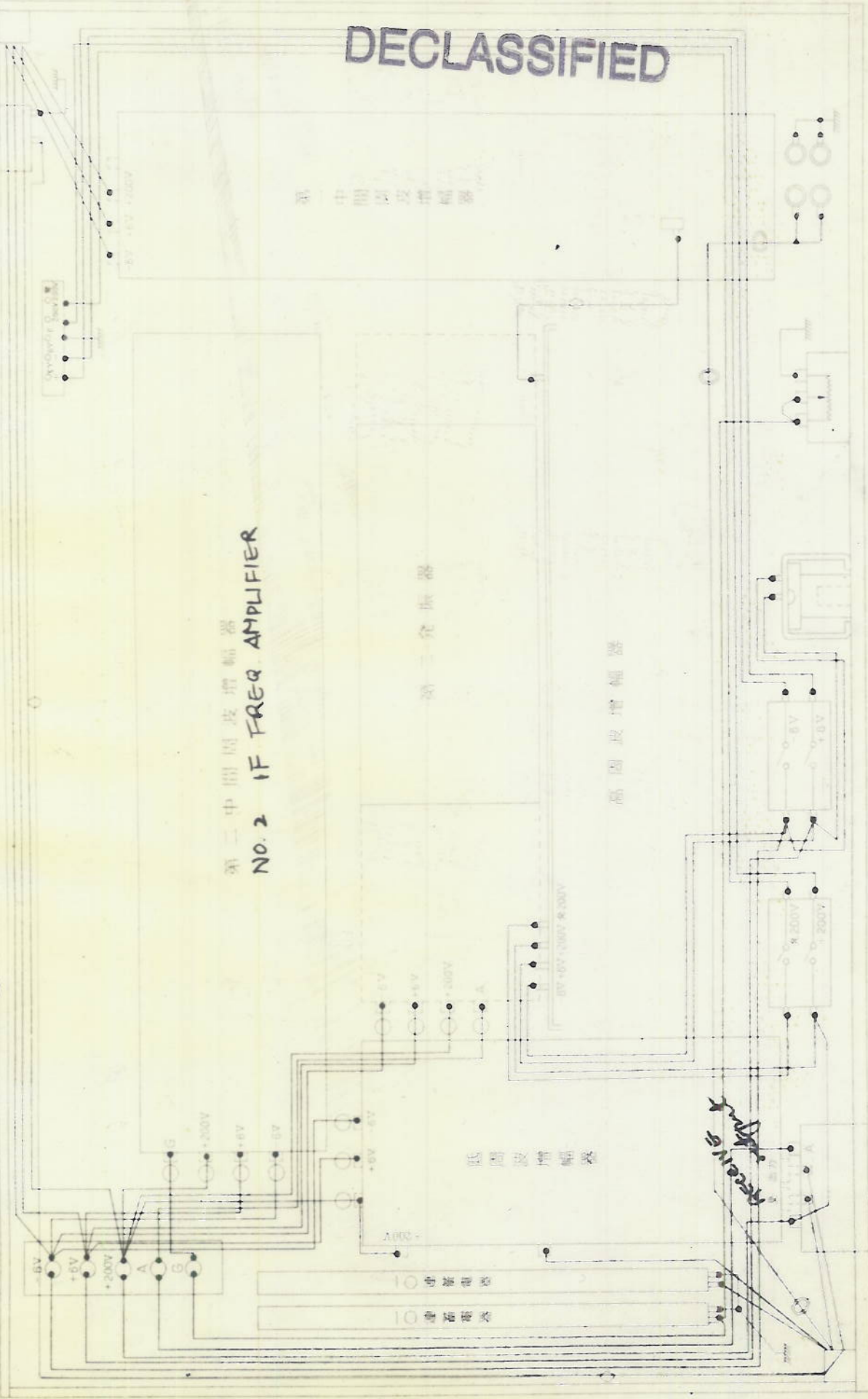

第二中間周波増幅器  
NO. 2 IF FREQ AMPLIFIER

受聴器  
出力調整  
出力調整ノツグ  
output meter  
調整ノツグ  
adjustment  
停示灯  
indicator lamp  
検出電流 (95)  
on plate off  
Power source  
Power source  
NO. 2 OSCILLATOR plate  
Power meter

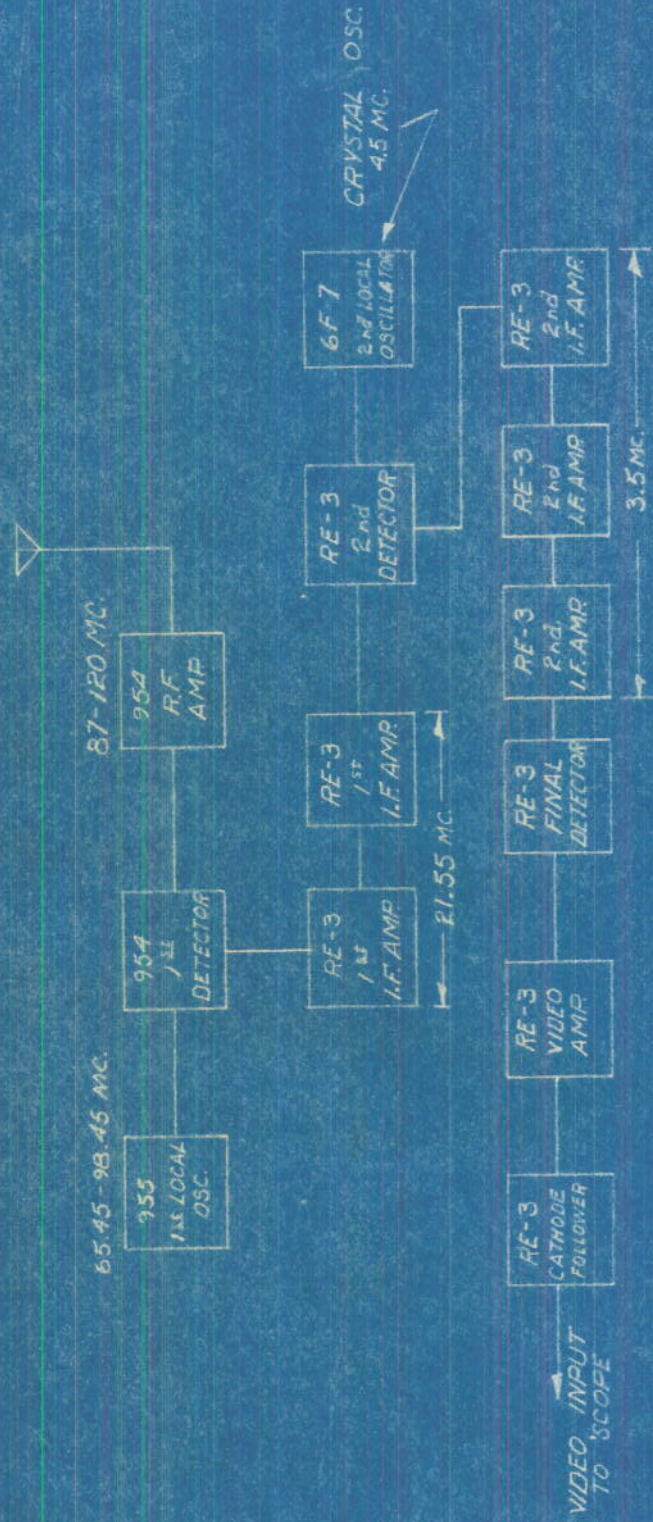

RECEIVER  
BLOCK DIAGRAM  
ATTU RADAR

DECLASSIFIED





15 KC

1/3 (3KC)

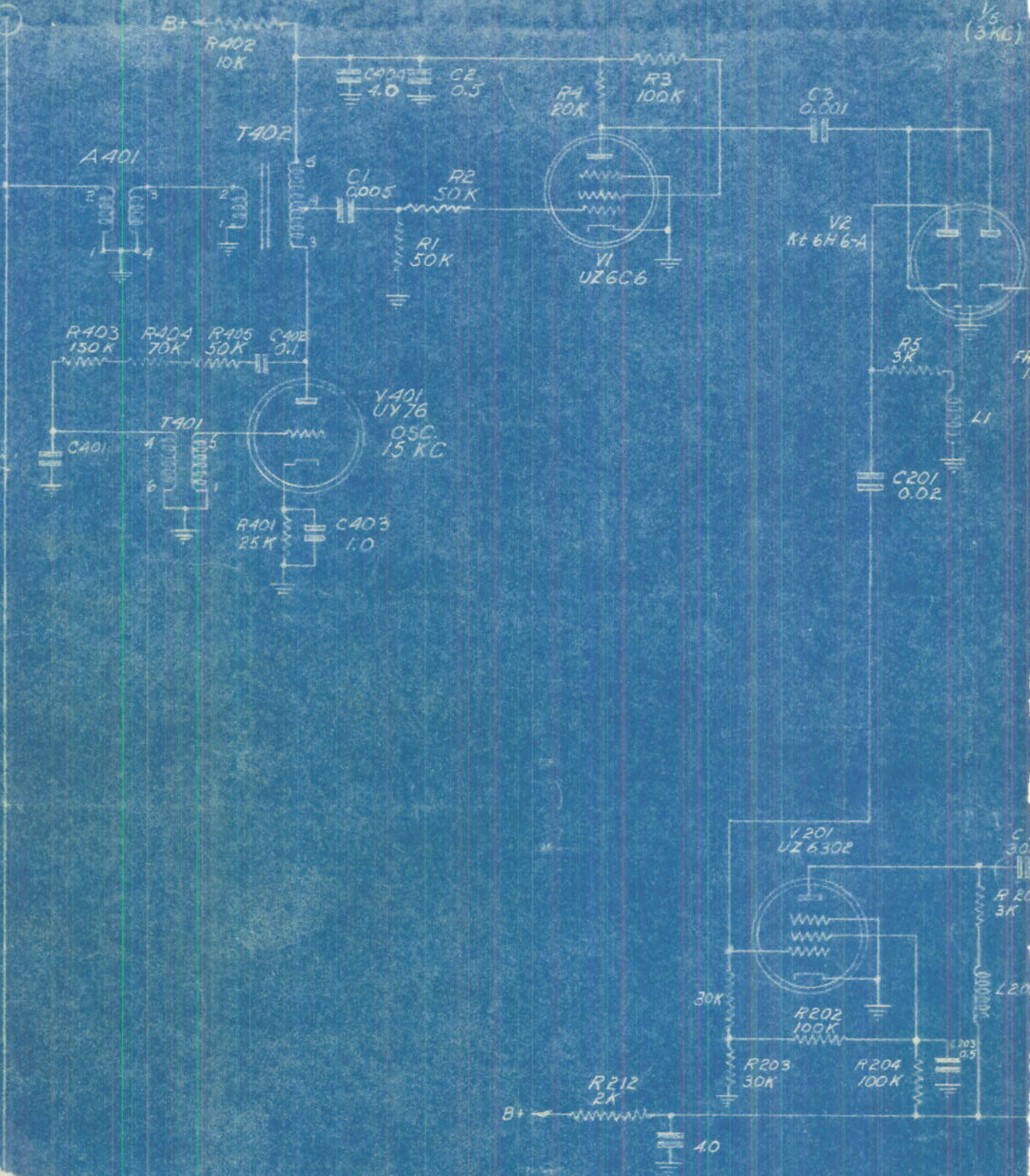

SYNCHRONIZATION UNIT  
ATTU RADAR

15 KC  
300 ~

DECLASSIFIED  
Plate 10

REPRODUCTION

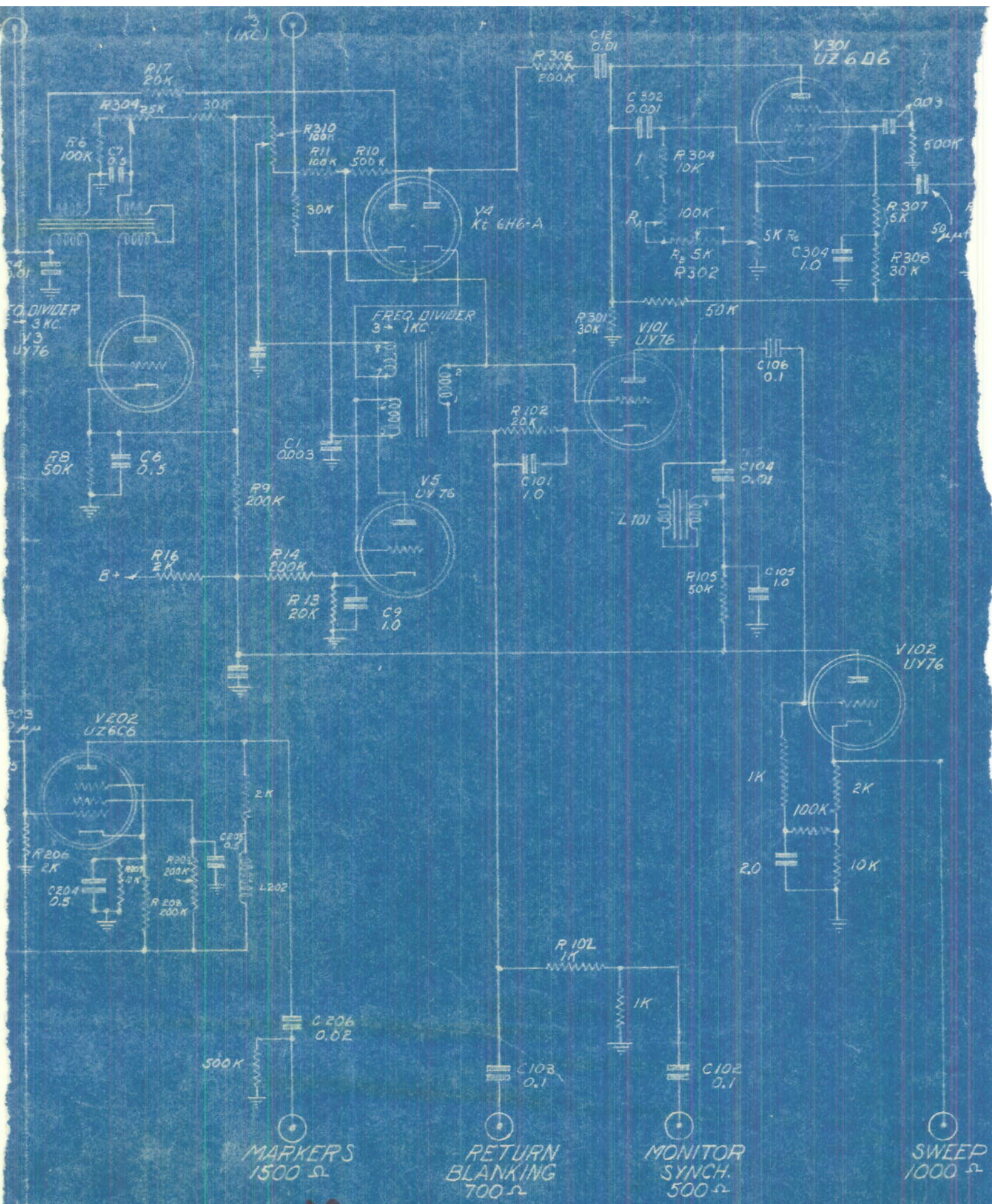
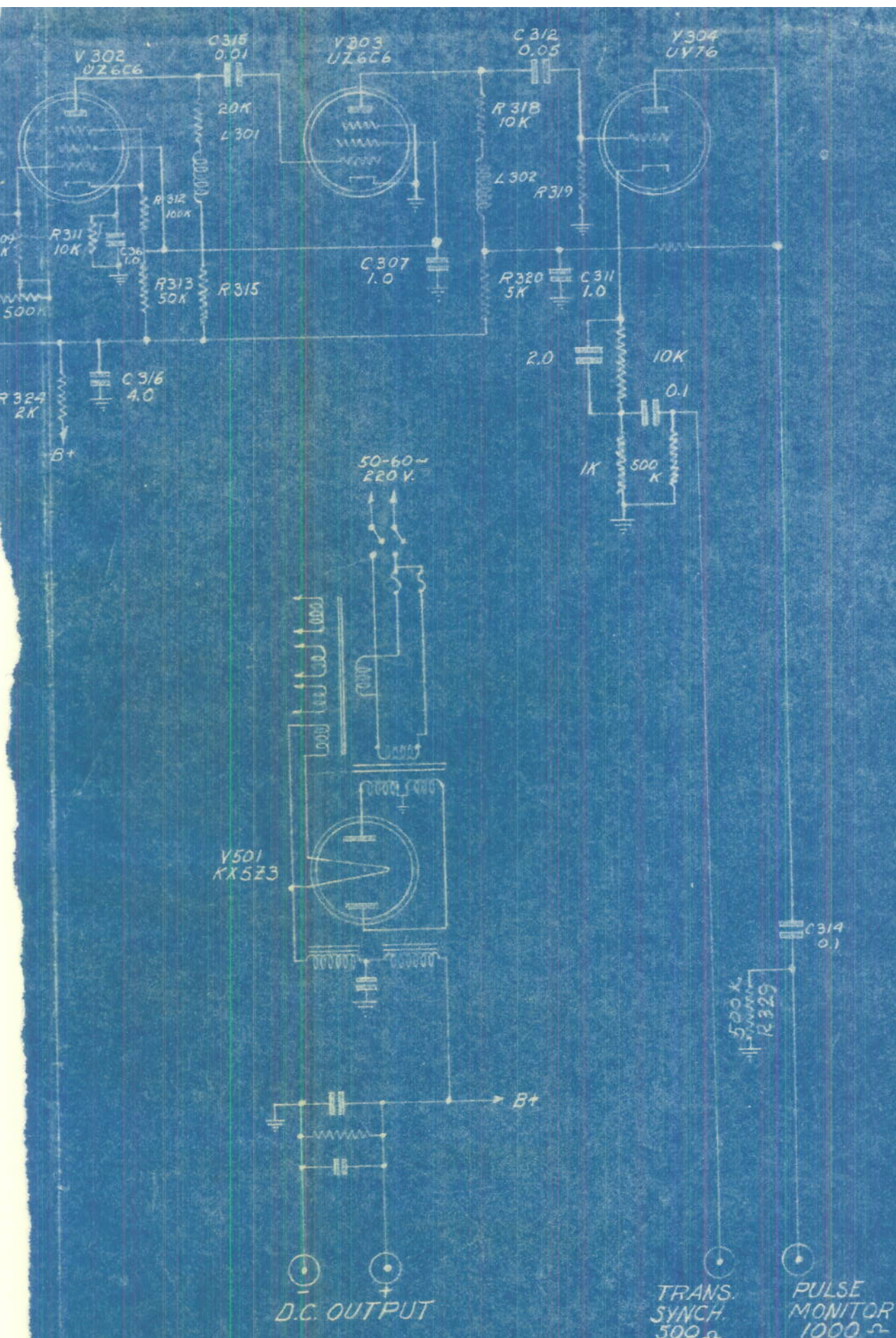
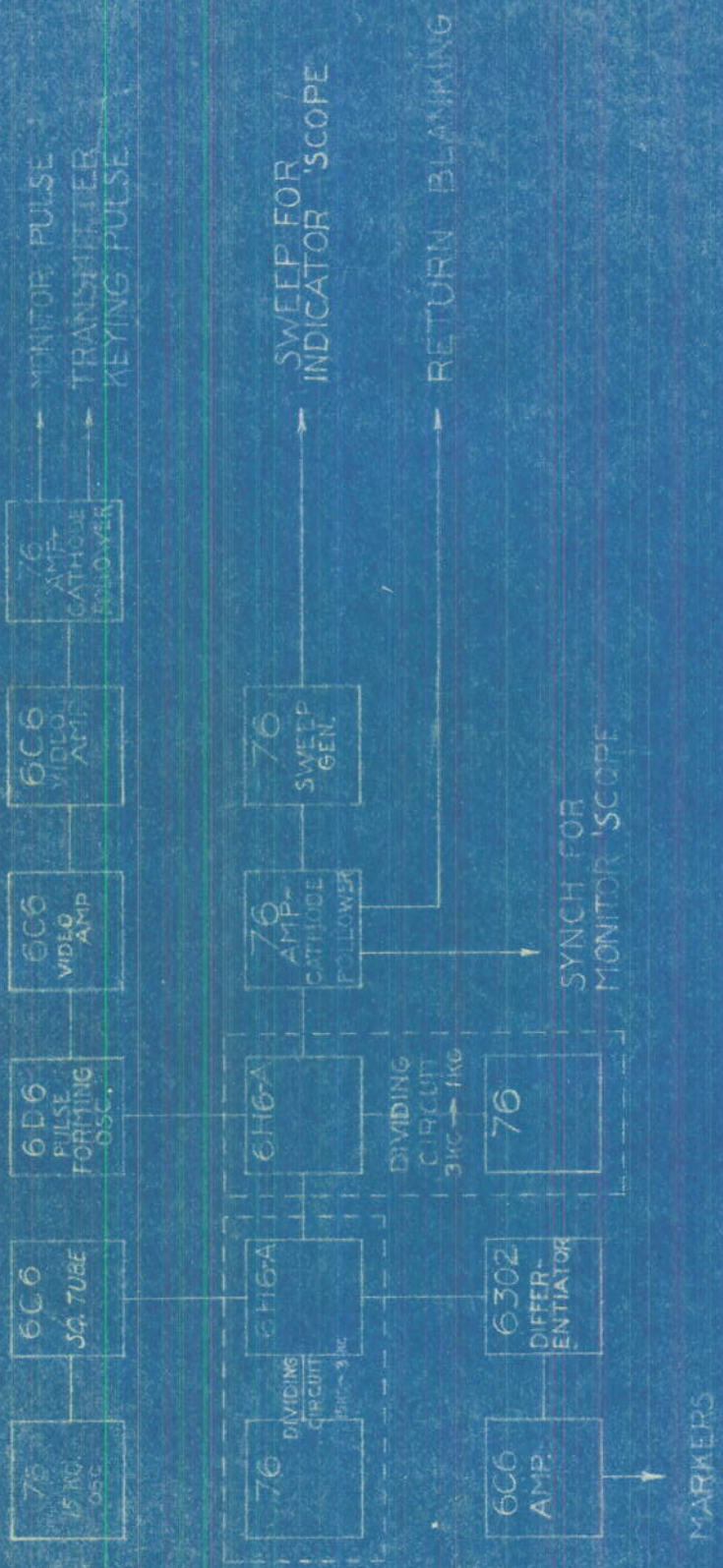

plate 10A





SYNCHRONIZING UNIT  
BLOCK DIAGRAM  
ATTU RADAR

DECLASSIFIED

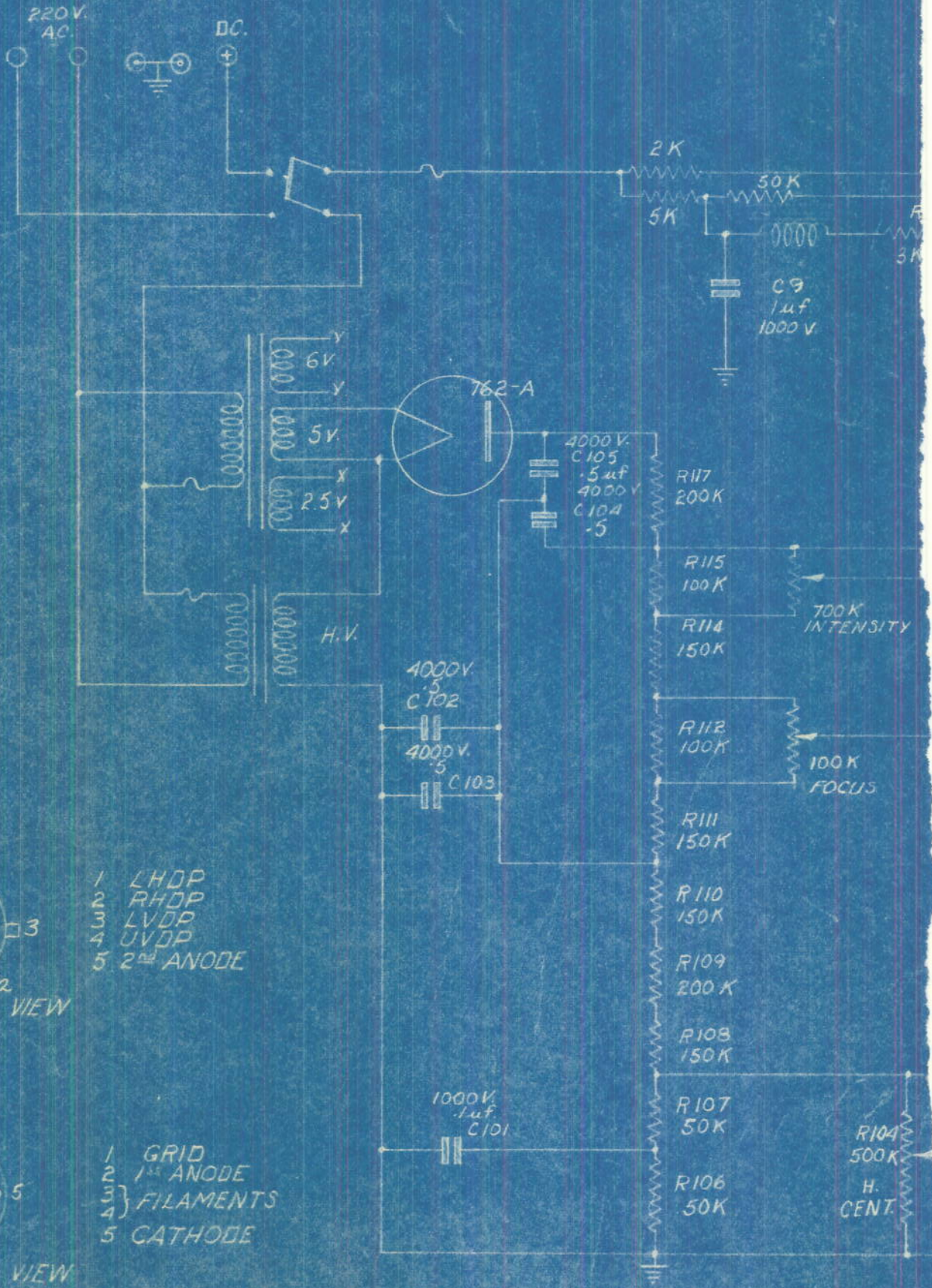

- 1 LHDP
- 2 RHDP
- 3 LVDP
- 4 UVDP
- 5 2<sup>nd</sup> ANODE

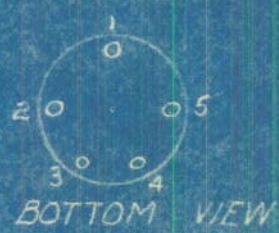

- 1 GRID
- 2 1<sup>st</sup> ANODE
- 3 } FILAMENTS
- 4 }
- 5 CATHODE

SSE 120 G

plate 12

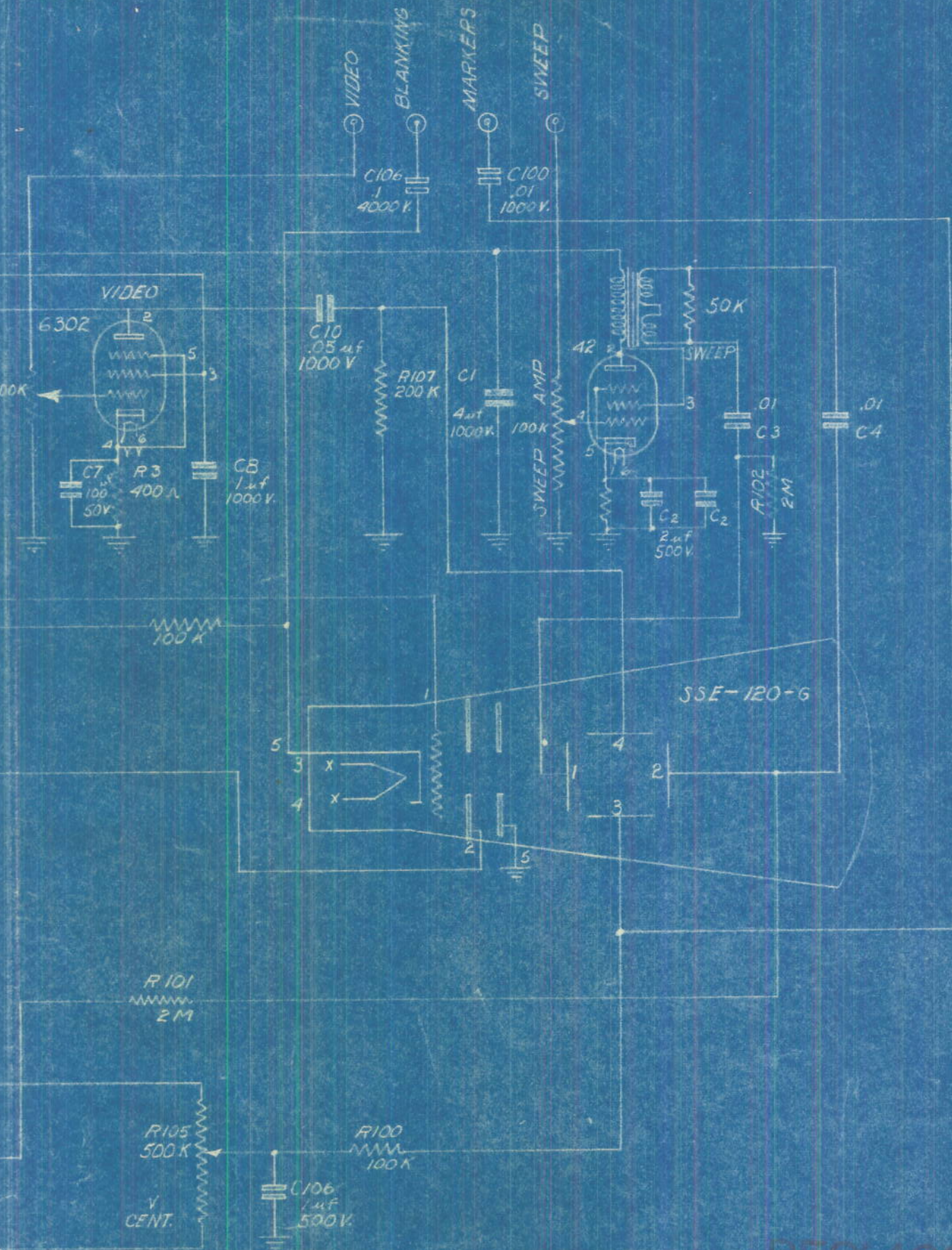

MAIN INDICATOR  
ATTU RADAR

DECLASSIFIED

PLATE 12 **A**

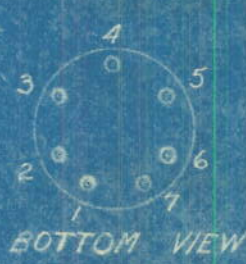
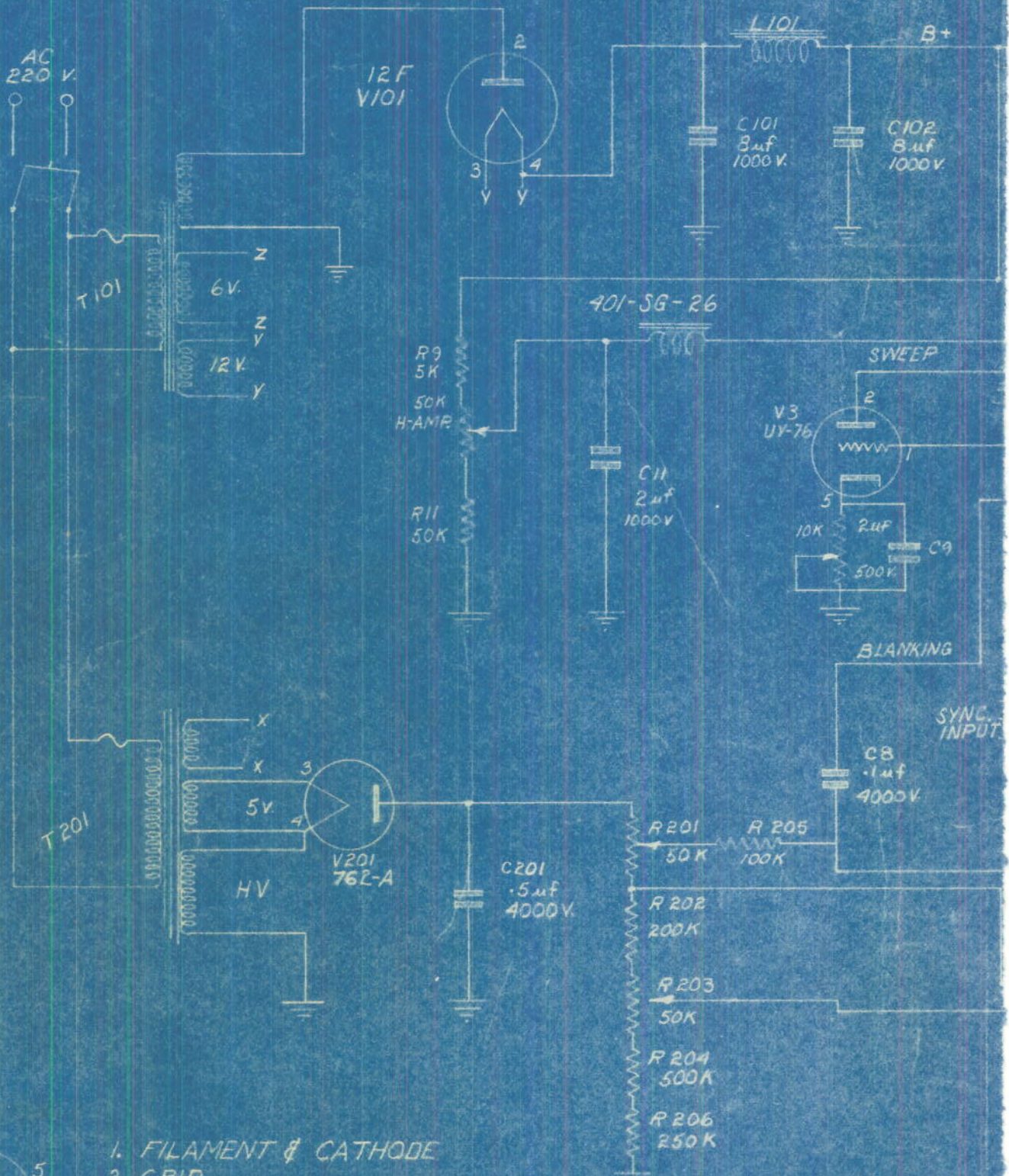

- 1. FILAMENT & CATHODE
- 2. GRID
- 3. UVDP
- 4. 1<sup>st</sup> ANODE
- 5. RHDP
- 6. 2<sup>nd</sup> ANODE, LVDP, LHDP
- 7. FILAMENT

SSE-75-G

Plate 13

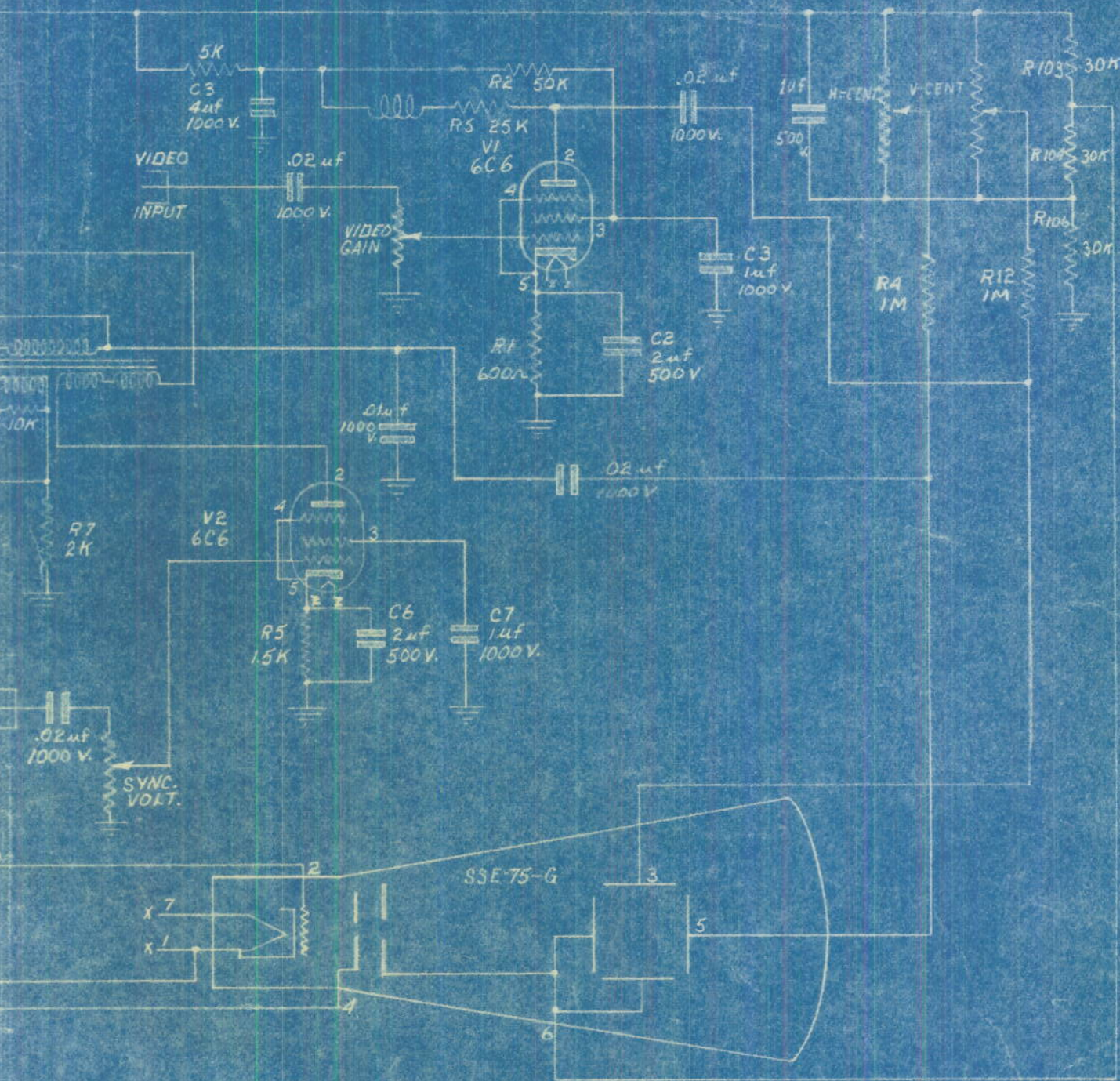

MONITOR SCOPE  
ATTU RADAR

DECLASSIFIED

PLATE 13A



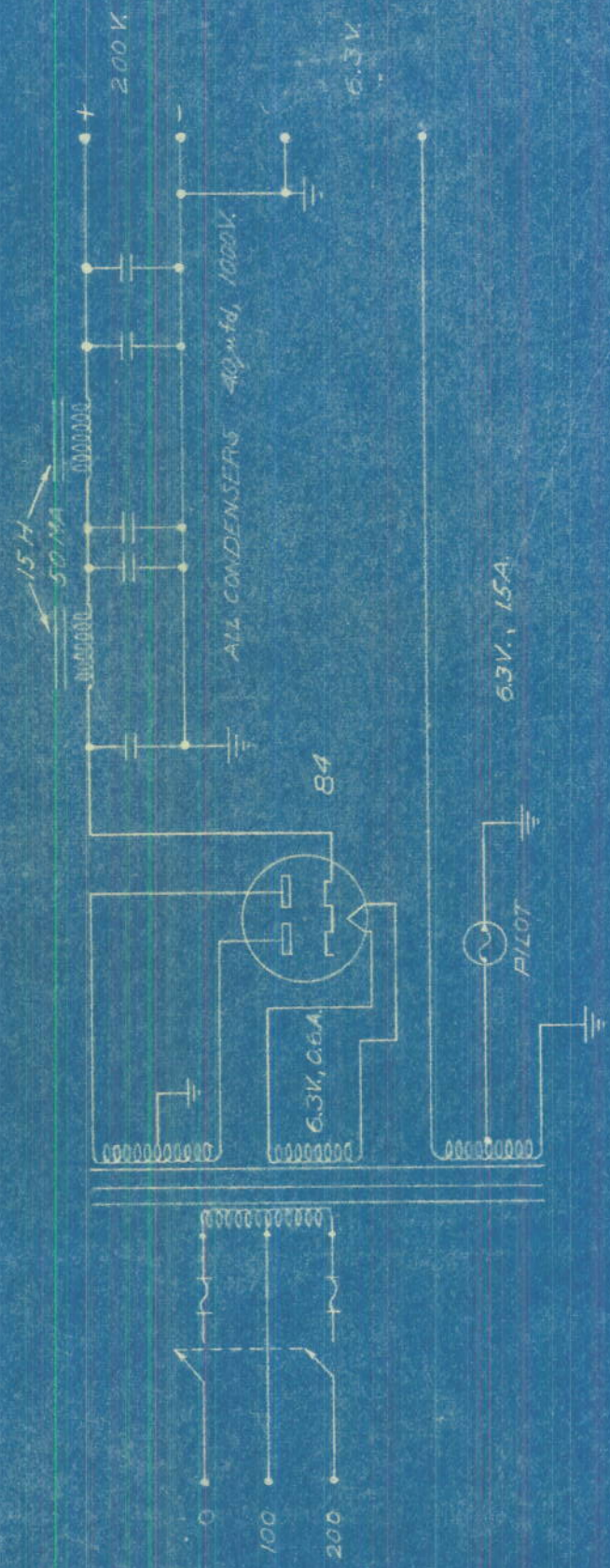

WAVEMETER POWER SUPPLY  
ATTU RADAR

DECLASSIFIED

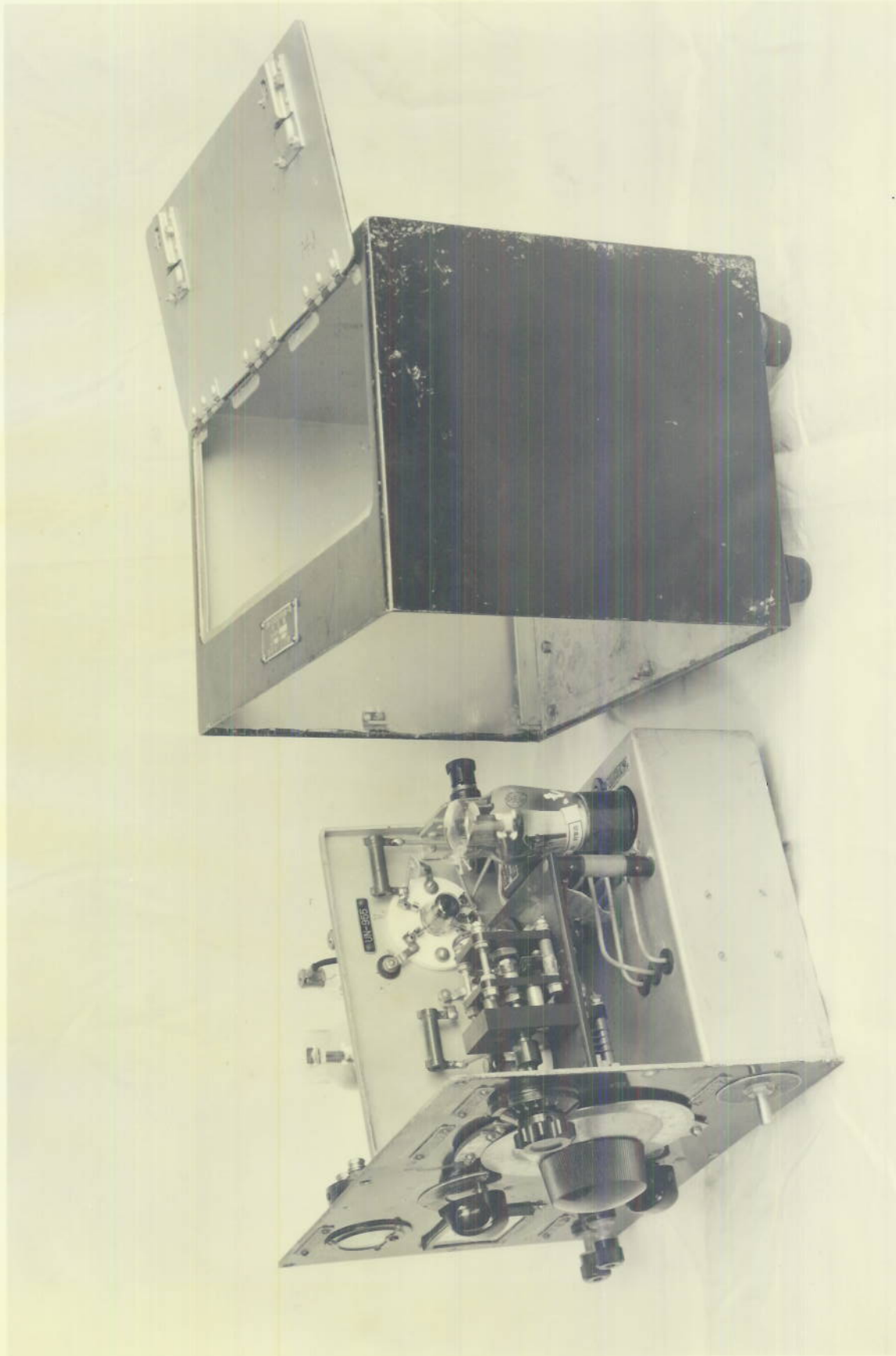

**CONFIDENTIAL**

**DECLASSIFIED**

**PLATE 16**

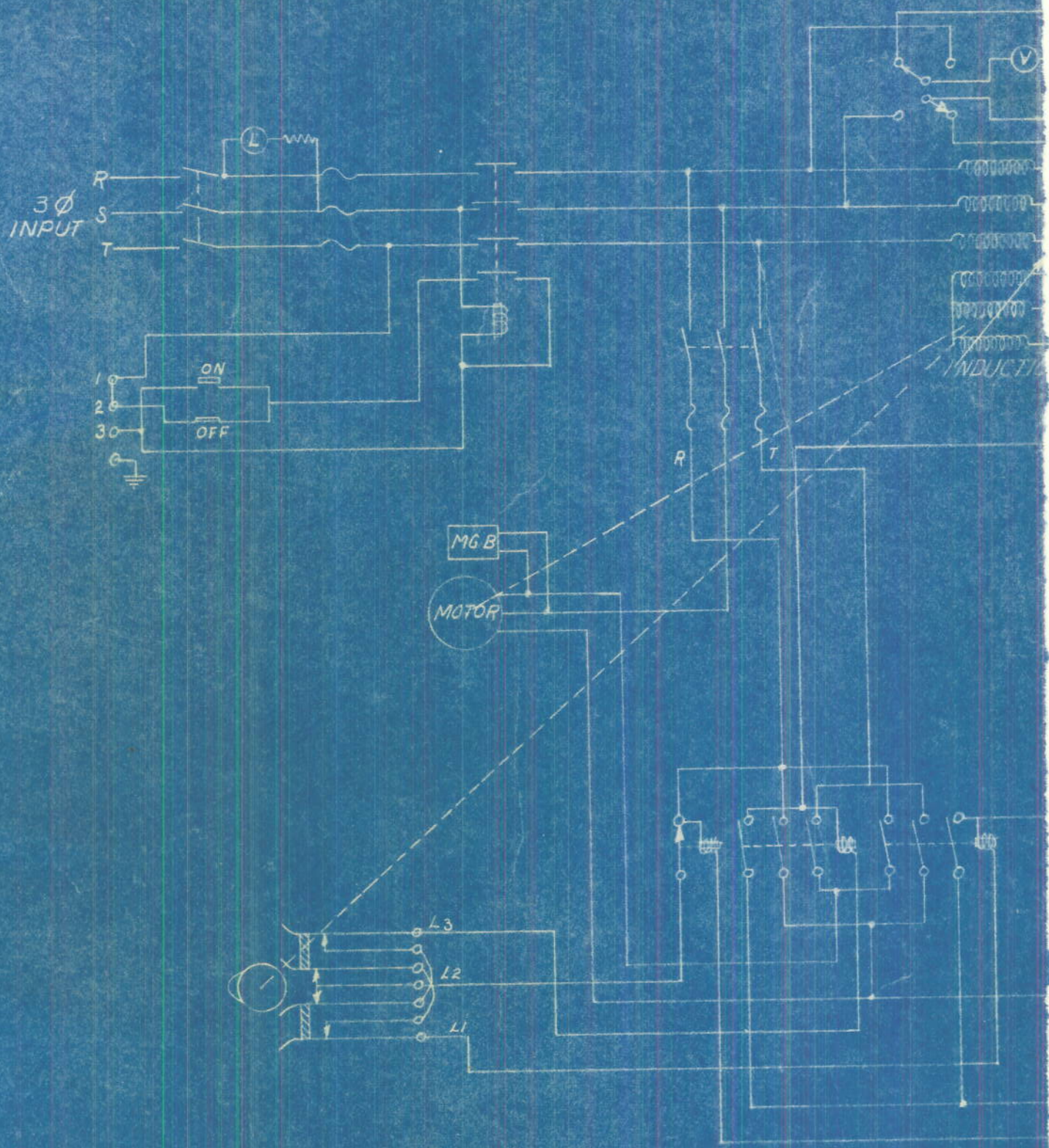

THREE PHASE VO  
ATTU A

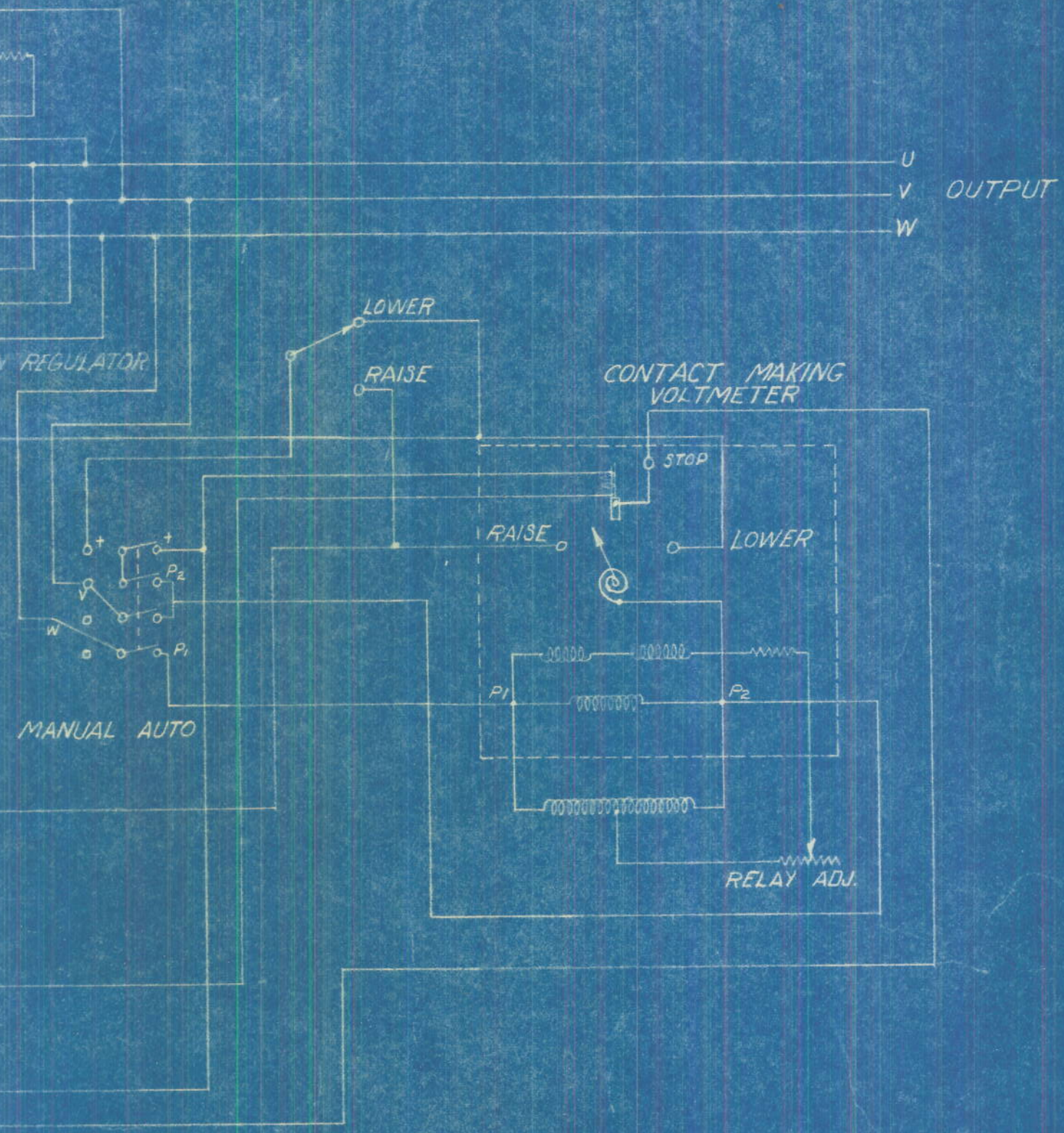

VOLTAGE REGULATOR  
ADAR

DECLASSIFIED

Plate 17A

PLATE 17

3718  
EOLAE

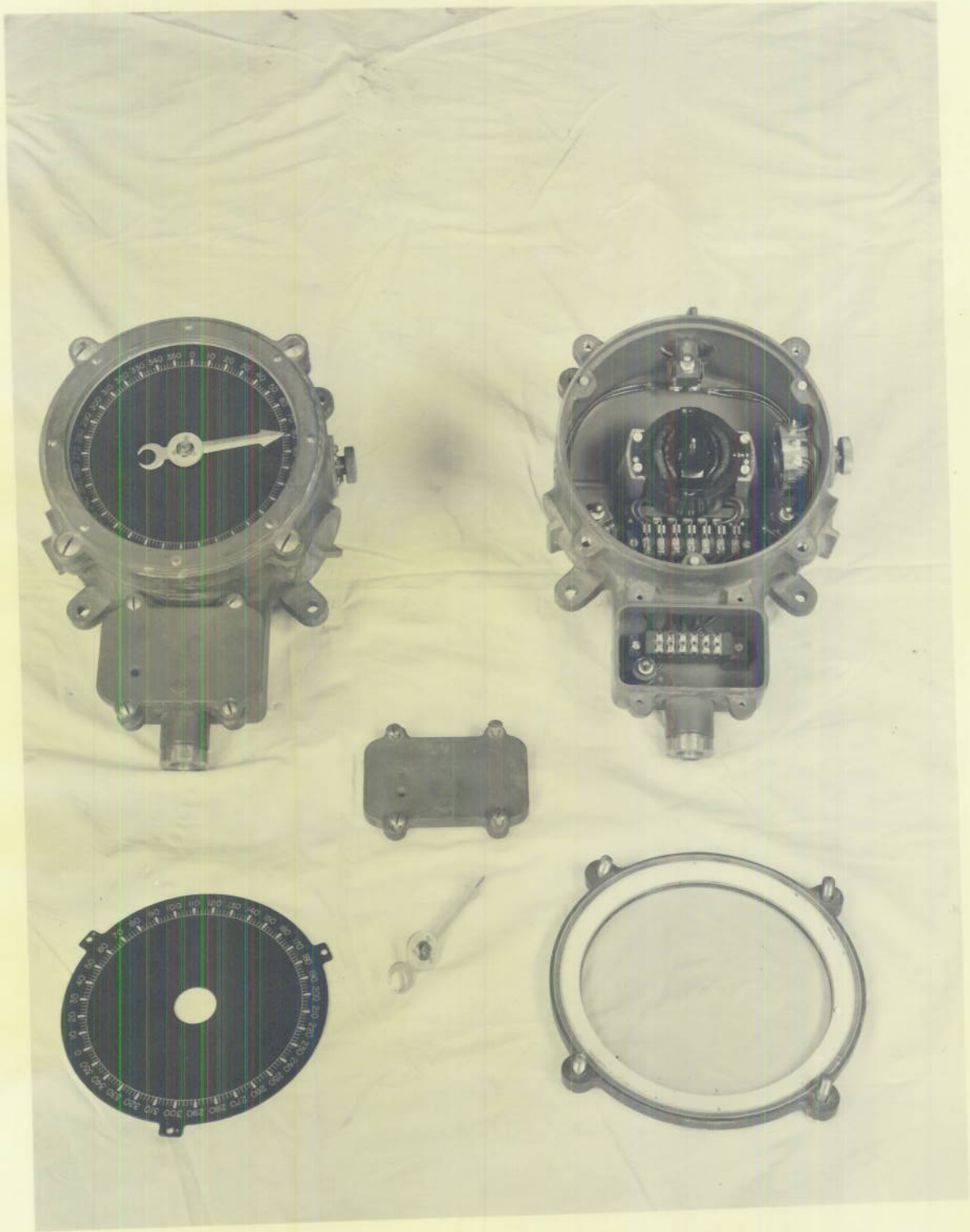

DECLASSIFIED

**CONFIDENTIAL**

PLATE 18



DECLASSIFIED

PLATE 19

CONFIDENTIAL

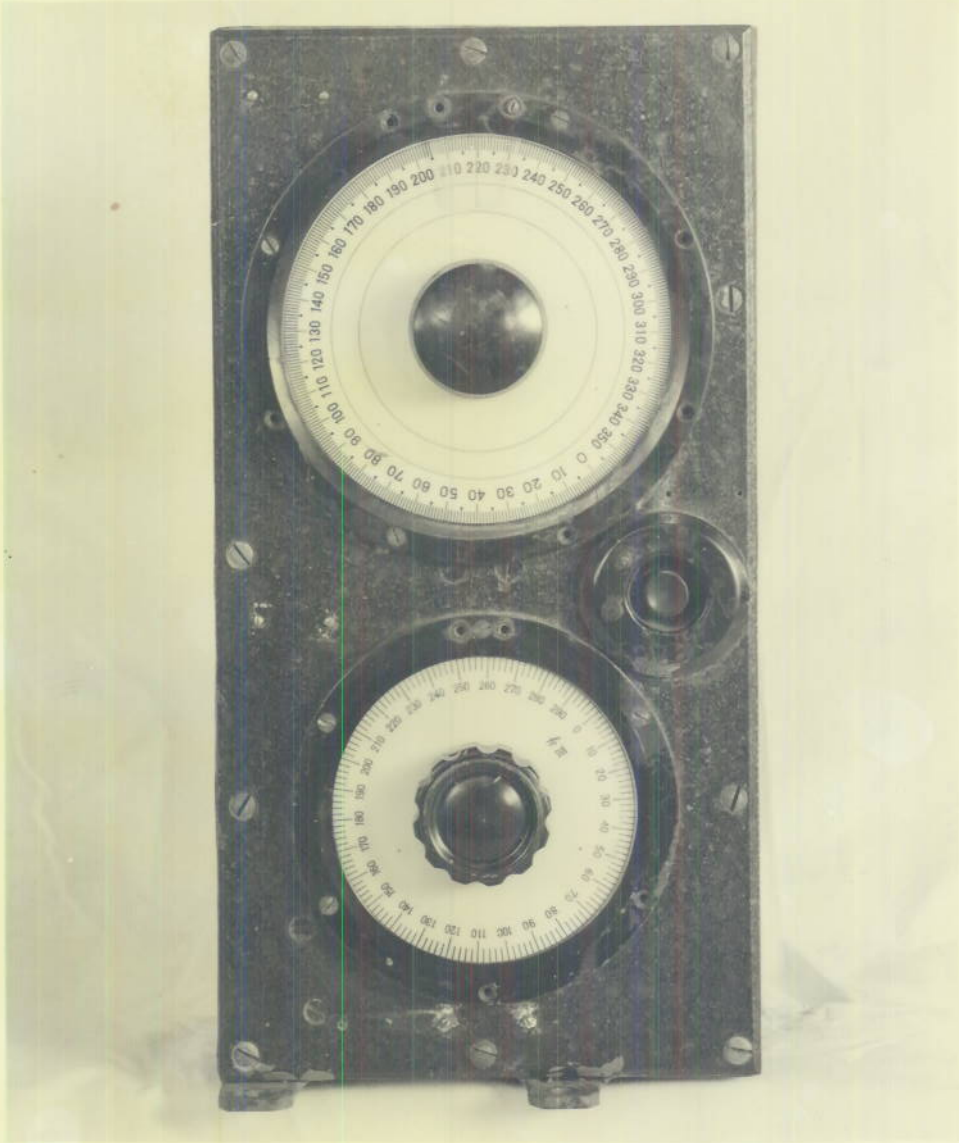

DECLASSIFIED

~~CONFIDENTIAL~~

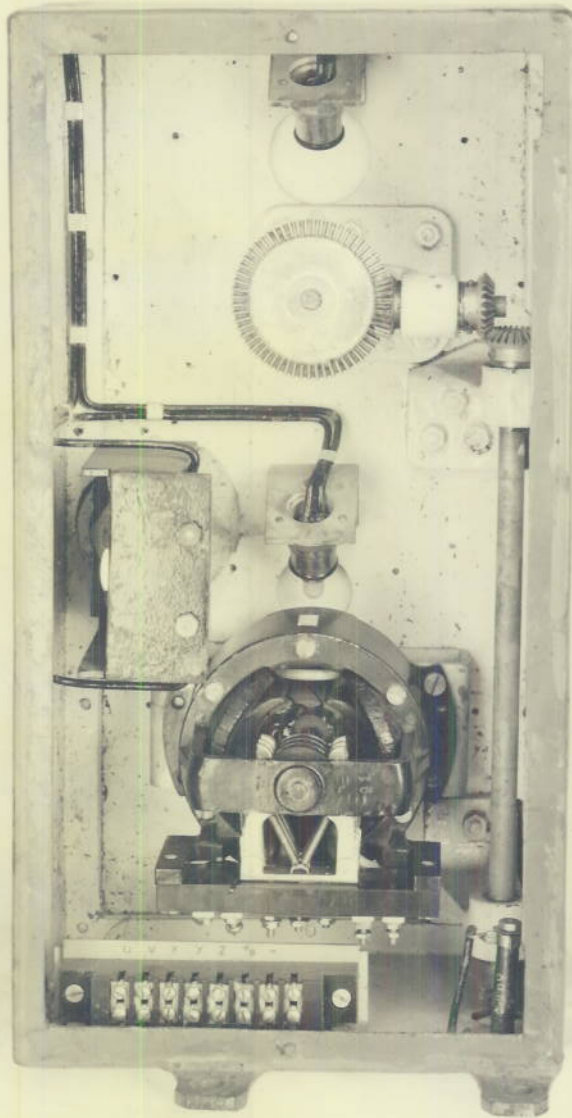

DECLASSIFIED

PLATE 21

~~CONFIDENTIAL~~



1



2



3



4

APPENDIX I

TRANSLATION OF TRANSMITTER PARTS LIST (PLATE 4).

| No. | Name  | Total | Remarks                        |
|-----|---|-------|--------------------------------|
| 1   | Grid Coil                                       | 1     |                                |
| 2   | Grid By-Pass Condenser                          | 1     | 0.005 mfd<br>D.C. 75 V Mica    |
| 3   | Grid Current Meter (Main Oscillator)            | 1     | D.C. 50 MA                     |
| 4   | Meter (Gauge) "A" Safeguard Condenser           | 7     | 0.005 mfd<br>D.C. 1500 Mica    |
| 5   | Arrestor Fuse                                   | 1     | Vacuum Type 30 MA              |
| 6   | Mercury Arrestor                                | 3     |                                |
| 7   | Main Oscillator Tube                            | 1     | TR-593-A                       |
| 8   | Main Oscillator Tube                            | 1     | TR-593-A                       |
| 9   | Plate Closed Elec. Circuit Coil(Main Osc.)      | 1     |                                |
| 10  | Plate Condenser (Main Oscillator)               | 1     |                                |
| 11  | Filament Tuning Coil                            | 1     |                                |
| 12  | Filament Tuning Coil                            | 1     |                                |
| 13  | Filament Tuning Condenser                       | 1     |                                |
| 14  | Filament Tuning Condenser                       | 1     |                                |
| 15  | Plate By-Pass Condenser                         | 1     | 0.002 mfd<br>D.C. 15000 V Mica |
| 16  | Coupling Condenser                              | 1     |                                |
| 17  | Coupling Condenser                              | 1     |                                |
| 18  | Grid Choke Coil                                 | 1     |                                |
| 19  | Grid By-Pass Condenser                          | 1     | 0.005 mfd<br>D.C. 7500 V Mica  |
| 20  | Grid Current Meter (Amplifier)                  | 1     | D.C. 50 MA                     |
| 21  | Arrestor Fuse                                   | 1     | Vacuum Type 30                 |
| 22  | Mercury Arrestor                                | 3     |                                |
| 23  | Grid Closed Elec. Circuit Condenser (Amplifier) | 1     |                                |
| 24  | Grid Closed Elec. Circuit Coil                  | 1     |                                |
| 25  | Amplifier Tube                                  | 1     | TR-593-A                       |
| 26  | Amplifier Tube                                  | 1     | TR-593-A                       |
| 27  | Neutralizing Condenser                          | 1     |                                |
| 28  | Neutralizing Condenser                          | 1     |                                |
| 29  | Filament By-Pass Condenser                      | 1     | 100 mmfd                       |
| 30  | Filament By-Pass Condenser                      | 1     | 100 mmfd                       |
| 31  | Filament Choke Coil                             | 1     |                                |
| 32  | Filament Choke Coil                             | 1     |                                |
| 33  | Plate Closed Electric Circuit (Amplifier)       | 1     |                                |
| 34  | Plate Condenser (Amplifier)                     | 1     |                                |
| 35  | Plate Choke Coil                                | 1     |                                |
| 36  | Plate By-Pass Condenser                         | 1     | 0.002 mfd<br>D.C. 15000 V Mica |
| 37  | Plate Voltage Switch                            | 1     |                                |
| 38  | Antenna Coupling Coil                           | 1     |                                |
| 39  | Feeder Circuit Current Meter                    | 1     | 1 A                            |
| 40  | Feeder Circuit Current Meter                    | 1     | 1 A                            |

~~CONFIDENTIAL~~

DECLASSIFIED

APPENDIX I (cont.)

| No. | Name  | Total | Remarks                         |
|-----|---|-------|---------------------------------|
| 41  | By-Pass Condenser                             | 1     | 0.005 mfd<br>D.C. 1500 V Mica   |
| 42  | Closed Circuit Coil (Monitoring Rectifier)    | 1     |                                 |
| 43  | Closed Circuit Condenser                      | 1     |                                 |
| 44  | Monitoring Rectifier Tube                     | 1     | D.C.-782-A                      |
| 45  | Plate Choke Coil                              | 1     |                                 |
| 46  | Plate Resistor                                | 1     | C-5 2000 ohms                   |
| 47  | Filament By-Pass Condenser                    | 1     | 0.005 mfd<br>D.C. 1500 V Mica   |
| 48  | Filament Resistor                             | 1     | 4 ohm enamelled                 |
| 49  | Filament Voltage Meter                        | 1     | AC 15 V                         |
| 50  | Filament Changeover Switch                    | 1     |                                 |
| 51  | Filament Transformer (Main Oscillator)        | 1     | 7.5 V 35A                       |
| 52  | Filament Transformer (Amplifier)              | 1     | 7.5 V 35A                       |
| 53  | Plate Current Meter (Main Oscillator)         | 1     | DC-300 mA                       |
| 54  | Plate Current Meter (Amplifier)               | 1     | DC-300 mA                       |
| 55  | Overload Relay (Main Oscillator)              | 1     | 0.0-0.3 A                       |
| 56  | Overload Relay (Amplifier)                    | 1     | 0.0-0.3 A                       |
| 57  | Overload Parrell Resistor                     | 1     | 40 ohm Enamel                   |
| 58  | Overload Parrell Resistor                     | 1     | 40 ohm Enamel                   |
| 59  | Overload Moving Indicator Lamp                | 1     | 18 V 75 mA                      |
| 60  | Overload Moving Indicator Lamp                | 1     | 18 V 75 mA                      |
| 61  | Overload Series Resistor                      | 1     | 2600 ohm Enamel                 |
| 62  | Overload Series Resistor                      | 1     | 2600 ohm Enamel                 |
| 63  | Overload Relay Reset                          | 1     |                                 |
| 64  | Grid Voltage Meter                            | 1     | D.C. 1000 V                     |
| 65  | Multiplier                                    | 1     |                                 |
| 66  | Multiplier Changeover Switch                  | 1     |                                 |
| 67  | Plate Voltage Meter                           | 1     | D.C. 8000 V                     |
| 68  | Multiplier                                    | 1     |                                 |
| 69  | Multiplier Changeover Switch                  | 1     |                                 |
| 70  |   |       |                                 |
| 71  | Main Power Supply Fuse                        | 3     | 30 A                            |
| 72  | Power Supply Indicator Lamp                   | 1     | 18 V 75 mA Red                  |
| 73  | Power Supply Series Resistor                  | 1     | 2600 ohms                       |
| 74  | Main Power Supply Switch                      | 1     |                                 |
| 75  | Filament Power Supply Control Switch          | 1     |                                 |
| 76  | Filament Electro-Magnetic Switch              | 1     |                                 |
| 77  | Filament Fuse                                 | 1     | 5 A                             |
| 78  | Air Blast Electro-Magnetic Switch             | 1     |                                 |
| 79  | Air Blast Fuse                                | 3     | 10 A                            |
| 80  | Timing Relay                                  | 1     |                                 |
| 81  | Grid Power Supply Control Switch              | 1     |                                 |
| 82  | Grid Power Source Electro-Magnetic Switch     | 1     |                                 |
| 83  | Modulator Fuse                                | 1     | 2 A                             |
| 84  | Grid Power Source Fuse                        | 1     | 2 A                             |
| 85  | Grid Power Source Rectifier                   | 1     | 122 VA 5000 V<br>Pressure Proof |
| 86  | Grid Power Source Rectifier Plate Transformer | 1     | 176 VA                          |

APPENDIX I (cont.)

| No. | Name   | Total | Remarks                                     |
|-----|--|-------|---|
| 87  | Grid Power Supply Rectifier Tube                       | 1     | K-251                                       |
| 88  | Grid Power Supply Rectifier Tube                       | 1     | K-251                                       |
| 89  | Smoothing Choke Coil                                   | 1     | 30 H 0.11 A 6 KV                            |
| 90  | Smoothing Condenser                                    | 1     | 3 mfd OF DC 3 KV                            |
| 91  | Voltage Dividing Resistor                              | 1     | 1300 ohms Enamel                            |
| 92  | Smoothing Condenser                                    | 1     | 3 mfd OF DC 3000 V                          |
| 93  | Smoothing Condenser                                    | 1     | 3 mfd OF DC 3000 V                          |
| 94  |  |       |   |
| 95  | Plate Power Supply Fuse                                | 2     | 10 -  |
| 96  | Plate Power Supply Push Button Switch                  | 1     |   |
| 97  | Plate Power Supply Electro-Magnetic Switch             | 1     |   |
| 98  | Plate Power Supply Indicator Lamp                      | 1     | 18 V 75 ma                                  |
| 99  | Plate Series Resistor                                  | 1     | 2600 ohms Enamel                            |
| 100 | Plate Voltage Changeover Switch                        | 1     |   |
| 101 | Voltage Regulator Reactor                              | 1     | 0.4 H                                       |
| 102 | Plate Power Supply Rectifier Filament Transformer Tube | 1     | 10 V 12 A 122 VA<br>20 KV Pressure Proof    |
| 103 | Plate Power Supply Rectifier Filament Transformer Tube | 1     | 122 VA 20 KV<br>10 V 12 A<br>Pressure Proof |
| 104 | Plate Power Supply Rectifier Tube                      | 1     | K-251                                       |
| 105 | Plate Power Supply Rectifier Tube                      | 1     | K-251                                       |
| 106 | Plate Power Supply Rectifier Tube                      | 1     | K-251                                       |
| 107 | Plate Power Supply Rectifier Tube                      | 1     | K-251                                       |
| 108 | Plate Transformer for Plate Power Supply Rectifier     | 1     | 1.4 KVA                                     |
| 109 | Plate Transformer for Plate Power Supply Rectifier     | 1     | 640 VA                                      |
| 110 | Smoothing Choke Coil                                   | 1     | 4 H 0.3 A 6000 V                            |
| 111 | Smoothing Condenser                                    | 2     | 2 mfd OF DC-15000 V                         |
| 112 | Smoothing Choke Coil                                   | 1     | 11 H 0.65 A 10 KV                           |
| 113 | Smoothing Condenser                                    | 2     | 2 mfd OF DC-15000 V                         |
| 201 | Series Resistance Condenser                            | 1     | 0.005 mfd 1000 V                            |
| 202 | Input Adjustable Changeover Switch                     | 1     | MK-12451                                    |
| 204 | Automatic Bias Resistor                                | 1     | C-3 2K ohms                                 |
| 205 | Synchronous Input Amplifier Tube                       | 1     | UZ-42                                       |
| 206 | Audio Transformer                                      | 1     | 202-SB-5                                    |
| 207 | Grid Resistor  | 1     | C-3 100 K ohms                              |
| 208 | Impulse Wave Intermediate Driver Tube                  | 1     | XB-767-A                                    |
| 209 | Impulse Wave Load Resistor                             | 1     | 3K ohm Enamel                               |
| 210 | Impulse Wave Discharge Condenser                       | 2     | 0.002 mfd 5000 V                            |
| 211 | Variable Resistor                                      | 1     | Model 819 160K ohms                         |
| 212 | Choke Coil   | 1     | 15 mH                                       |
| 213 | Impulse Wave Amplifier Tube                            | 1     | TB-508-C                                    |
| 214 | Power Supply Smoothing Condenser                       | 1     | 6 mfd 1500 V                                |
| 215 | "  | 1     | 2 mfd 2000 V                                |
| 216 | Power Supply Smoothing Low Freq. Choke Coil            | 1     | 15 H 40 ma                                  |
| 217 | Power Supply Rectifier                                 | 1     | KX-12-F                                     |
| 218 | Power Supply Transformer                               | 1     | 66 VA                                       |

CONFIDENTIAL

DECLASSIFIED

APPENDIX I (cont.)

| No. | Name                                     | Total | Remarks          |
|-----|--|-------|------------------|
| 219 | Power Supply Rectifier Tube              | 1     | KX-142           |
| 220 | Power Supply Filter Resistor             | 1     | C-5 70K ohms     |
| 221 | Power Supply Filter Condenser            | 1     | 3 mfd 3000 V     |
| 222 | Power Supply Filter Resistor             | 1     | C-3 10K ohms     |
| 223 | Power Supply Filter Condenser            | 1     | 2 mfd 2000 V DC  |
| 224 | "  | 1     |                  |
| 225 | Voltage Allotment Resistor               | 1     | C-3 10 K ohms    |
| 226 | Power Supply Rectifier Tube              | 1     | KX-12F           |
| 227 | Power Supply Filter Condenser            | 1     | 2 mfd 5000 V     |
| 228 | Power Supply Filter Low Freq. Choke Coil | 1     |                  |
| 229 | Power Supply Rectifier Tube              | 1     | KX-142           |
| 230 | Power Supply Allotment Resistor          | 1     | C-5 4K ohms      |
| 231 | "  | 1     | C-3 2K ohms      |
| 232 | "  | 1     | "                |
| 233 | "  | 1     | "                |
| 234 | "  | 1     | C-5 70K ohms     |
| 235 | Impulse Wave Load Resistor               | 1     | 200 ohms Enamel  |
| 236 | "  | 1     | 2000 ohms        |
| 237 | Series Resistance Condenser              | 1     | 2 mfd 2000 V     |
| 238 | Input Adjustable Resistor                | 1     | M 1/3L 30K ohms  |
| 239 | By-Pass Condenser                        | 1     | 2 mfd 2000 V     |
| 240 | Power Supply Filter Condenser            | 1     | 2 mfd 5000 V     |
| 241 | Rikenohm                                 | 1     | 20K ohms M-1/3 L |
| 242 | Impulse Wave Discharge Resistor          | 6     | C-1 50K ohms     |
| 243 | Power Supply Transformer                 | 1     | 135 VA           |
| 244 | Power Supply Rectifier Tube              | 1     | KX-142.          |

APPENDIX II

TRANSLATION OF RECEIVER PARTS LIST

Feeder Circuit High Frequency Amplifier - No. 1 Detector - No. 1 Oscillator

| <u>Symbol</u> | <u>Name</u>                             | <u>Fixed Number</u> | <u>Summary</u> |
|---------------|---|---------------------|----------------|
| V1            | UN-954                                  |                     | Acorn Socket   |
| V2            | "                                       |                     | "              |
| V3            | UN-955                                  |                     | "              |
| VC1           | Midget Condenser                        | 20 mmfd.            |                |
| VC2           | "                                       | "                   |                |
| VC3           | "                                       | "                   |                |
| C1            | Naval Type Model 2                      | 0.002 mfd           |                |
| C2            | "                                       | "                   |                |
| C3            | "                                       | "                   |                |
| C4            | "                                       | "                   |                |
| C5            |   | 0.5 mfd             |                |
| C6            | Naval Type Model 2                      | 0.002 mfd           |                |
| C7            | Naval Type Porcelain Terminal Condenser | 0.5 mfd             |                |
| C9            | Naval Type Model 2                      | 0.0001 mfd          |                |
| C10           | "                                       | 1 mmfd              |                |
| C11           | "                                       | 0.002 mfd           |                |
| C12           | "                                       | "                   |                |
| C13           | "                                       | "                   |                |
| C14           | "                                       | "                   |                |
| C15           | "                                       | "                   |                |
| C16           | "                                       | "                   |                |
| C17           | "                                       | "                   |                |
| C18           | "                                       | "                   |                |
| C19           | "                                       | "                   |                |
| C20           | "                                       | 0.002 mfd           |                |
| C21           | "                                       | "                   |                |
| C22           | "                                       | "                   |                |
| C23           | "                                       | "                   |                |
| R1            | Naval Type C-0.5 Purple Color           | .500 ohms           | Rikenohm       |
| R2            | "                                       | 1 K ohm             | "              |
| R3            | " Yellow Color                          | 30 K ohm            | "              |
| R4            | Naval Type B-20 Orange Color            | 50 K ohm            | "              |
| R5            | "                                       | 100 K ohms          | "              |
| R6            | " Red Color                             | 5 K ohms            |                |
| L1            | Feeder Circuit Tuning Coil              |                     |                |
| L2            | "                                       |                     |                |
| L3            | Amplifier Tuning Coil                   |                     |                |
| L4            | "                                       |                     |                |
| L5            | Oscillator Tuning Coil                  |                     |                |
| L6            | Plate Choke Coil                        |                     | N-16114        |
| L7            | "                                       |                     | "              |
| L8            | "                                       |                     | "              |
| L9            | "                                       |                     | "              |
| L10           | Filament Choke Coil                     |                     | "              |
| L11           | "                                       |                     | "              |

APPENDIX II (cont.)

| <u>Symbol</u>   | <u>Name</u>                             | <u>Fixed Number</u> | <u>Summary</u> |
|---|---|---------------------|----------------|
| L12   | Filament Choke Coil                     |                     | N-16114        |
| L13   | "                                       |                     | "              |
| No. 1 Intermediate Frequency Amplifier No. 2 Detector |   |                     |                |
| V4  | RE-3                                    |                     |                |
| V5  | "                                       |                     |                |
| V6  | "                                       |                     |                |
| VC4   | Midget Condenser                        | 50 mmfd             |                |
| VC5   | "                                       | "                   |                |
| VC6   | "                                       | "                   |                |
| VC7   | "                                       | "                   |                |
| VC8   | "                                       | "                   |                |
| VC9   | "                                       | "                   |                |
| C25   | Naval Type Model 2                      | 0.01 mfd            |                |
| C27   | Naval Type Model 2                      | 0.01 mfd            |                |
| C29   | Naval Type Model 2                      | 0.01 mfd            |                |
| C30   | Naval Type Model 2                      | 0.01 mfd            |                |
| C31   | Naval Type Model 2                      | 0.01 mfd            |                |
| C32   | Naval Type Model 2                      | 0.01 mfd            |                |
| C33   | Naval Type Porcelain Terminal Condenser | 0.5 mfd             |                |
| C34   | Naval Type Model 2                      | 0.01 mfd            |                |
| C35   | Naval Type Porcelain Terminal Condenser | 0.5 mfd             |                |
| C36   | Naval Type Model 2                      |                     |                |
| C37   | Naval Type Porcelain Terminal Condenser | 0.5 mfd             |                |
| C38   | Naval Type Model 2                      | 0.002 mfd           |                |
| C39   | "                                       | "                   |                |
| C40   | "                                       | "                   |                |
| C41   | "                                       | "                   |                |
| C42   | "                                       | "                   |                |
| C43   | "                                       | "                   |                |
| C44   | "                                       | "                   |                |
| C45   | "                                       | "                   |                |
| C46   | "                                       | "                   |                |
| C47   | "                                       | "                   |                |
| C48   | "                                       | "                   |                |
| C49   | "                                       | "                   |                |
| C50   | "                                       | 0.01 mfd            |                |
| C51   | "                                       | "                   |                |
| C52   | "                                       | "                   |                |
| R7  | Naval Type $\frac{1}{2}$ C              | 100 K ohms          | Rikenohm       |
| R8  | "                                       | "                   | "              |
| R9  | "                                       | "                   | "              |
| R10   | "                                       | "                   | "              |
| R11   | "                                       | "                   | "              |
| R12   | "                                       | "                   | "              |
| R13   | Naval Model C-0.5 Red Color             | 1 K ohm             |                |
| R14   | "                                       | "                   | "              |

APPENDIX II (cont.)

| <u>Symbol</u> | <u>Name</u>                        | <u>Fixed Number</u> | <u>Summary</u> |
|---------------|------------------------------------|---------------------|----------------|
| R15           | Naval Model C-0.5 Red Color        | 1 K ohm             | Rikenohm       |
| R16           | " Purple Color                     | 250 ohms            | "              |
| R17           | "                                  | "                   | "              |
| R18           | Naval Model B-20 Red Color         | 5 K ohms            | "              |
| R19           | "                                  | "                   | "              |
| R20           | "                                  | "                   | "              |
| R21           | " Orange Color                     | 30 K ohms           | "              |
| R22           | "                                  | "                   | "              |
| R23           | "                                  | 100 K ohms          | "              |
| R62           | Naval Type $\frac{1}{2}$ Model L   | 100                 | "              |
| R63           | "                                  | "                   | "              |
| R64           | "                                  | "                   | "              |
| L14           | Intermediate Frequency Tuning Coil |                     | N-16112        |
| L15           | "                                  |                     | "              |
| L16           | "                                  |                     | "              |
| L17           | "                                  |                     | "              |
| L18           | "                                  |                     | "              |
| L19           | "                                  |                     | "              |
| L20           | Plate Choke Coil                   |                     | N-16114        |
| L21           | "                                  |                     | "              |
| L22           | "                                  |                     | "              |
| L23           | "                                  |                     | "              |
| L24           | "                                  |                     | "              |
| L25           | "                                  |                     | "              |
| L26           | Filament Choke Coil                |                     | "              |
| L27           | "                                  |                     | "              |
| L28           | "                                  |                     | "              |
| L29           | "                                  |                     | "              |
| L30           | "                                  |                     | "              |
| L31           | "                                  |                     | "              |

No. 2 Oscillator

|      |                    |           |       |
|------|--------------------|-----------|-------|
| V7   | 6 F 7              |           | Ut-7P |
| VC10 | Midget Condenser   | 50 mmfd   |       |
| VC11 | "                  | 25 mmfd   |       |
| C53  | Naval Type Model 2 | 0.01 mfd  |       |
| C54  | "                  | "         |       |
| C55  | "                  | "         |       |
| C56  | "                  | "         |       |
| C57  | "                  | "         |       |
| C58  | "                  | "         |       |
| C59  | "                  | 0.002 mfd |       |
| C60  | "                  | "         |       |
| C61  | "                  | "         |       |
| C62  | "                  | 0.01 mfd  |       |
| C63  | "                  | "         |       |

APPENDIX II (cont.)

| <u>Symbol</u> | <u>Name</u>                   | <u>Fixed Number</u> | <u>Summary</u> |
|---------------|-------------------------------|---------------------|----------------|
| C64           | Naval Type Model 2            | 0.01 mfd            |                |
| C65           | "                             | "                   |                |
| R24           | Naval Type C-0.5 Purple Color | 1 K ohm             | Rikenohm       |
| R25           | " Red Color                   | "                   | "              |
| R26           | " "                           | "                   | "              |
| R27           | " Yellow Color                | 1 M ohm             | "              |
| R28           | Naval Type C-2 Red Color      | 5 K ohm             | "              |
| R29           | "                             | 5 K ohm             | "              |
| R30           | " Orange Color                | 30 K ohms           | "              |
| L32           | Oscillator Coil               |                     | N-16114        |
| L33           | "                             |                     | "              |
| L34           | "                             |                     | "              |
| L35           | Plate Choke Coil              |                     | N-16114        |
| L36           | "                             |                     | "              |
| L37           |                               |                     | "              |
| L38           | Filament Choke Coil           |                     | "              |
| L39           | "                             |                     | "              |
| X             | Crystal Oscillator            | 4.5 MC              |                |

No. 2 Intermediate Frequency Amplifier - No. 3 Detector

|      |   |          |  |
|------|---|----------|--|
| V8   | RE-3                                    |          |  |
| V9   | "                                       |          |  |
| V10  | "                                       |          |  |
| V11  | "                                       |          |  |
| VC12 | Midget Condenser                        | 50 mmfd  |  |
| VC13 | "                                       | "        |  |
| VC14 | "                                       | "        |  |
| VC15 | "                                       | "        |  |
| VC16 | "                                       | "        |  |
| VC17 | "                                       | "        |  |
| VC18 | "                                       | "        |  |
| VC19 | "                                       | "        |  |
| C74  | Naval Type Model 2                      | 0.01 mfd |  |
| C75  | "                                       | "        |  |
| C76  | "                                       | "        |  |
| C77  | "                                       | "        |  |
| C78  | "                                       | "        |  |
| C79  | "                                       | "        |  |
| C80  | "                                       | "        |  |
| C81  | "                                       | "        |  |
| C82  | "                                       | "        |  |
| C83  | Naval Type Porcelain Terminal Condenser | 0.5 mfd  |  |
| C84  | "                                       | "        |  |
| C85  | "                                       | "        |  |
| C86  | Naval Type Model 2                      | 0.01 mfd |  |
| C87  | "                                       | "        |  |
| C88  | "                                       | "        |  |
| C89  | "                                       | "        |  |
| C90  | "                                       | "        |  |

APPENDIX II (cont.)

| <u>Symbol</u> | <u>Name</u>                        | <u>Fixed Number</u> | <u>Summary</u> |
|---------------|------------------------------------|---------------------|----------------|
| C91           | Naval Type Model 2                 | 0.01 mfd            |                |
| C92           | "                                  | "                   |                |
| C93           | "                                  | "                   |                |
| C94           | "                                  | "                   |                |
| C95           | "                                  | "                   |                |
| C96           | "                                  | "                   |                |
| C97           | "                                  | "                   |                |
| C98           | "                                  | 0.002 mfd           |                |
| C99           | "                                  | "                   |                |
| C100          | "                                  | "                   |                |
| C101          | "                                  | 0.01 mfd            |                |
| C102          | "                                  | "                   |                |
| C103          | "                                  | "                   |                |
| C104          | "                                  | "                   |                |
| C123          | "                                  | "                   |                |
| R31           | Naval Type $\frac{1}{2}$ C         | 15 K ohm            | Rikenohm       |
| R32           | "                                  | "                   | "              |
| R33           | "                                  | "                   | "              |
| R34           | "                                  | "                   | "              |
| R35           | "                                  | "                   | "              |
| R36           | "                                  | "                   | "              |
| R37           | "                                  | "                   | "              |
| R38           | "                                  | "                   | "              |
| R39           | Naval Type C-0.5 Red Color         | 1 K ohm             | "              |
| R40           | "                                  | "                   | "              |
| R41           | "                                  | "                   | "              |
| R42           | "                                  | "                   | "              |
| R43           | " Purple Color                     | 250 ohm             | "              |
| R44           | "                                  | "                   | "              |
| R45           | "                                  | "                   | "              |
| R46           | " Red Color                        | 5 K ohm             | "              |
| R47           | "                                  | "                   | "              |
| R48           | "                                  | "                   | "              |
| R49           | "                                  | "                   | "              |
| R50           | " Orange Color                     | 30 K ohm            | "              |
| R51           | "                                  | "                   | "              |
| R52           | "                                  | "                   | "              |
| R65           | Naval Type 1/3 Model L             | 100 ohm             | "              |
| R66           | "                                  | "                   | "              |
| R67           | "                                  | "                   | "              |
| L40           | Intermediate Frequency Tuning Coil |                     | N-16112        |
| L41           | "                                  |                     | "              |
| L42           | "                                  |                     | "              |
| L43           | "                                  |                     | "              |
| L44           | "                                  |                     | "              |
| L45           | "                                  |                     | "              |
| L46           | "                                  |                     | "              |

CONFIDENTIAL

DECLASSIFIED

APPENDIX II (cont.)

| <u>Symbol</u> | <u>Name</u>                        | <u>Fixed Number</u> | <u>Summary</u> |
|---------------|------------------------------------|---------------------|----------------|
| L47           | Intermediate Frequency Tuning Coil |                     | N-16112        |
| L48           | Plate Choke Coil                   |                     | N-16114        |
| L49           | "                                  |                     | "              |
| L50           | "                                  |                     | "              |
| L51           | "                                  |                     | "              |
| L52           | "                                  |                     | "              |
| L53           | "                                  |                     | "              |
| L54           | "                                  |                     | "              |
| L55           | "                                  |                     | "              |
| L56           | Filament Choke Coil                |                     | "              |
| L57           | "                                  |                     | "              |
| L58           | "                                  |                     | "              |
| L59           | "                                  |                     | "              |
| L60           | "                                  |                     | "              |
| L61           | "                                  |                     | "              |
| L62           | "                                  |                     | "              |

Low Frequency Amplifier

|      |   |            |           |
|------|---|------------|-----------|
| V12  | RE-3                                    |            |           |
| V13  | RE-3                                    |            |           |
| C105 | Naval Type Porcelain Terminal Condenser | 0.5 mfd.   |           |
| C106 | "                                       | "          |           |
| C107 | Naval Type Model 2                      | 0.002 mfd. |           |
| C108 | Naval Type Porcelain Terminal Condenser | 2 mfd      | 0.5 x 4   |
| C109 | Naval Type Model 2                      | 0.002 mfd  |           |
| C110 | Naval Type Porcelain Terminal Condenser | 2.5        | 0.5 x 5   |
| C111 | Naval Type Model 2                      | 0.002 mfd  |           |
| C112 | "                                       | "          |           |
| C113 | "                                       | "          |           |
| C114 | "                                       | "          |           |
| C115 | "                                       | "          |           |
| C116 | Naval Type Porcelain Terminal Condenser | 0.5 mfd.   |           |
| C117 | Naval Type Model 2                      | 0.002 mfd  |           |
| C118 | Naval Type Porcelain Terminal Condenser | 5 mfd      | 0.5. x 10 |
| C119 | Naval Type Model 2                      | 0.002 mfd  |           |
| C120 | "                                       | "          |           |
| C121 | "                                       | "          |           |
| C122 | "                                       | "          |           |
| R53  | Naval Type C-0.5 Red Color              | 10 K ohm   | Rikenohm  |
| R54  | Naval Type C-2                          | "          | "         |
| R55  | Naval Type C-0.5 Yellow Color           | 100 K ohm  | "         |
| R56  | "                                       | "          | "         |
| R57  | " Purple Color                          | 1 K ohm    | "         |
| R58  | Naval Type B-20 Orange Color            | 30 K ohms  | "         |
| R59  | " Red Color                             | 5 K ohms   | Rikenohm  |
| R60  | "                                       | "          | "         |
| R61  | " C-0.5 Yellow Color                    | "          | "         |

DECLASSIFIED

APPENDIX II (cont.)

| <u>Symbol</u> | <u>Name</u>   | <u>Fixed Number</u> | <u>Summary</u>                                   |
|---------------|---|---------------------|--|
| L63           | Plate Choke Coil                                    |                     | N-16114  |
| L64           | "   |                     | "  |
| L65           | "   |                     | "  |
| L66           | "   |                     | "  |
| L67           | Filament Choke Coil                                 |                     | "  |
| L68           | "   |                     | "  |
| L69           | "   |                     | "  |
| L70           | "   |                     | "  |
| VR1           | Naval Type Variable Resistor for<br>Vessels (Ships) | 10 K ohms           | Kokawa No. 4<br>Model C                          |
| C124          | Naval Type Porcelain Terminal Condenser             | 5 mfd               | 0.5 x 10   |
| M             | No. 2 Oscillator Plate Current Meter                | 5 ma                | MO-Model 2                                       |
| S1            | Plate Power Supply Switch                           |                     | Temperature<br>Switch                            |
| S2            | Filament Power Supply Switch                        |                     | "  |
| P             | Pilot Lamp  | 6 V 0.1A            | Naval Type "E"<br>Special Model<br>Elec. Bulb #6 |
| J1            | Output Terminal                                     |                     |  |
| J2            | Receiver (Ear phone) Terminal                       |                     | N-16117  |
| J3            | "   |                     | KMK-204 "B"                                      |
| C125          | Naval Type Model 2                                  | 0.01 mfd            |  |
| C126          | "   | "                   |  |
| C127          | "   | "                   |  |
| C128          | "   | "                   |  |
| L71           |   |                     |  |
| L72           |   |                     |  |

## APPENDIX III\*

### TRANSLATION - TRANSMITTER INSTRUCTIONS

#### SECTION I ITEMS FOR CARE IN HANDLING

- order:
1. The operating of transmitter is in the following order:
    - (a) Switch on filament supply. (Will light up the filament of modulator and transmitter, and air-blast will start operating.)
    - (b) Switch on grid supply. (Thirty seconds after switching on time delay relay will start. Therefore, in switching on grid supply, grid supply and modulator will start operating.)
    - (c) Switch on plate supply. (To operate at adjusting position of plate voltage protector.)
    - (d) Reset of Plate Voltage Protector (Change to operating position from adjusting.) To turn off, change switch to off position in order of plate supply, grid supply, and filament supply.

#### SECTION II

##### CARE IN CHANGING THE TUBES

In the case of changing TR 503A, will adjust frequency by turning control I in the oscillator. In the amplifier, it is necessary to neutralize and to align. In this neutralizing act, first of all open up plate voltage switch (37) of the amplifier and to start the oscillator. Then adjust the grid tank condenser (23) and look for the maximum point of grid current of the amplifier.

Next, resonate the amplifier plate condenser. In other words, placing the neon tube on tank and look for the place where the light is strongest or the strongest point of the amplifier grid current.

Next, adjust the neutralizing condenser (27) (28) with neon and look for the strongest point of amplifier grid current. In this case the adjusting position of each neutralizing condenser is same. After perfecting the neutralizing act, close plate voltage switch (37), at the adjusting position of plate voltage switch on plate supply and by frequency adjuster II and in finding the adjusting point, the dip of plate current and the peak of grid current and the peak of aerial current will occur at the same time. In

### APPENDIX III (Cont'd)

this way to prevent the arcing of tube transmission should be continued for 30 minutes. After applying ageing to the tube change and use plate voltage changer to operating position. If the arcing of tube transmission continues, ageing should be done again.

#### SECTION III

##### CARE IN MAINTENANCE

In case of inspecting the inside of transmitter, open electric supply switch (74). In the plate electric supply high voltage current remains, so it is necessary to lead out the electric current by grounding rod. It is with the condenser.

#### SECTION IV

##### OTHERS

In the upper electrode of the mercury arrester (6) (22) it is best to have mercury at all times. In case of packing this transmitter for transporting it is best to take parts that are heavy off.

\*Reproduced from the report of reference (b). This is the translation of a sheet of operating instructions that was captured with the Attu equipment.

~~CONFIDENTIAL~~

DECLASSIFIED