



DEPARTMENT OF THE NAVY

OFFICE OF COUNSEL
NAVAL UNDERSEA WARFARE CENTER DIVISION
1176 HOWELL STREET NEWPORT RI 02841-1708

IN REPLY REFER TO

Attorney Docket No. 211145
12 October 2022

The below identified patent application is available for licensing. Requests for information should be addressed to:

TECHNOLOGY PARTNERSHIP OFFICE
NAVAL UNDERSEA WARFARE CENTER
1176 HOWELL ST.
CODE 00T2, BLDG. 102T
NEWPORT, RI 02841

Serial Number 17/881,677
Filing Date 5 August 2022
Inventor Richard E. Dooley

Address any questions concerning this matter to the Technology Partnership Office at (401) 832-3339.

DISTRIBUTION STATEMENT
Approved for Public Release
Distribution is unlimited

VARIABLE CAMBER SEGMENTED CONTROL SURFACE ASSEMBLY

CROSS REFERENCE TO RELATED APPLICATIONS

[0001] The present application is a divisional application and claims the benefit of United States Application Serial Number 17/020,872 filed on September 15, 2020 by the inventor Richard E. Dooley with the invention entitled "Variable Camber Segmented Control Surfaces".

STATEMENT OF GOVERNMENT INTEREST

[0002] The invention described herein may be manufactured and used by or for the Government of the United States of America for governmental purposes without the payment of any royalties thereon or therefor.

BACKGROUND OF THE INVENTION

(1) FIELD OF THE INVENTION

[0003] This application and the subject matter disclosed herein (collectively referred to as the "disclosure"), generally concern variable camber segmented control surfaces, and related systems and methods. More particularly, but not exclusively, this disclosure pertains to systems, methods, and components that use segmented levers assembled to articulate in both

positive and negative symmetric cambers by means of a single degree of freedom rotary actuation shaft. As but one illustrative example, an airfoil may have three or more segments hingeably connected together that collectively provide a control surface. The camber of the airfoil and the angle of attack can be varied by angular displacement of one of the segments.

(2) DESCRIPTION OF THE RELATED ART

[0004] A foil, such as an airfoil or a hydrofoil, is the cross-sectional shape of a wing, blade or sail. A foil-shaped structure moving through a fluid, e.g., water or air, produces an aerodynamic force having a lift component perpendicular to the direction of motion, and a drag component parallel to the direction of motion. The surface of the foil-shaped structure is referred to as a control surface. The shape of the control surface, e.g., its camber or curvature, and an angle of attack of the control surface relative to the direction of motion affects the amount of lift produced at a given speed.

[0005] The need for more control authority at slower speeds while maintaining minimal drag at higher speeds is always a challenge for control surface design for vehicles. Conventional approaches have increased the size of the control surface as needed due to volume limitations of the vehicle and control surface itself. A disadvantage to simply increasing the size of the control surface is that drag is increased at higher speeds.

Another disadvantage is that the larger control surfaces may interfere with external interfaces, e.g., with ports or launch tubes, or may require the external interfaces to be repositioned in the vehicle design.

[0006] Modern commercial aircraft include flap systems to vary the control surfaces of the aircraft wings. However, these flap systems are relatively complex, requiring mechanisms, e.g., multiple actuators, to extend a flap and to change the angle of the flap relative to the rest of the wing to change the size and camber of the control surface.

SUMMARY OF THE INVENTION

[0007] The disclosed embodiments provide a segmented control surface whose camber may be varied both positively and negatively with a single rotary actuation shaft. The disclosed embodiments may also provide increased lift compared to similarly sized angled symmetric airfoils.

[0008] In some respects, concepts disclosed herein generally concern variable camber segmented control surfaces. Some disclosed concepts pertain to systems, methods, and components to provide a control surface with an adjustable and variable camber controlled through a single degree of freedom actuator. As but one example, some disclosed control surfaces may have three or more segments hingeably connected together that

collectively provide the control surface. The camber of the airfoil and the angle of attack can be varied by angular displacement of one of the segments.

[0009] In one aspect, a variable camber wing for mounting to a vehicle chassis can have an actuator shaft extending from the vehicle chassis that is capable of angular rotation about an axis of the actuator shaft and a static pin affixed to the vehicle chassis. The wing can have a nose segment defining a proximal leading edge and a distal edge. The nose segment can have a channel through the segment and positioned between the proximal leading edge and the distal edge, an arcuate aperture therethrough aft of the channel, and a second aperture therethrough aft of the arcuate aperture. The nose segment has a head formed at the distal edge. The actuator shaft can be affixed in the channel to rotate the nose segment.

[0010] The wing can have a first linkage defining a clevis on a proximal end and a distal end aft of the proximal end. The first linkage can be configured to hingeably connect to the nose segment, wherein the clevis is complementarily configured to rotatably engage with the static pin extending through the arcuate aperture. The wing can have a second linkage defining a second clevis on a proximal end and a trailing distal edge. The second linkage can be configured to hingeably connect to the first linkage, wherein the second clevis is complementarily

configured to rotatably engage with the head of the nose segment.

[0011] The wing can have a pedestal affixed to the vehicle chassis, wherein the static pin and the actuator shaft extend orthogonally from the pedestal, and wherein the wing is arranged opposite the vehicle chassis relative to the pedestal.

[0012] The wing can have a smooth elastomeric coating fixed to and extending over the nose segment, the first linkage and the second linkage. The wing can define an asymmetrical airfoil when the nose segment is rotated with respect to the vehicle chassis by the actuator shaft to an actuation angle. The nose segment, the first linkage, and the second linkage in combination can define a first camber at a first actuation angle, and a second camber at a second actuation angle.

[0013] The first linkage can have a first hinge aperture therethrough aft of the clevis and configured to be aligned axially with the second aperture of the nose segment. The first linkage can be hingeably connected to the nose segment when a pin is inserted through the first hinge aperture and the second aperture.

[0014] The first linkage can have second hinge aperture therethrough aft of the first hinge aperture, and the second linkage can have a third hinge aperture therethrough aft of the second clevis. The third hinge aperture can be configured to

align axially with the second hinge aperture of the first linkage. The first linkage can be hingeably connected to the second linkage when a second pin is inserted through the aligned second and third hinge apertures.

[0015] The nose segment, the first linkage, and the second linkage can define a first variable camber wing rib, wherein the variable camber wing comprises a plurality of adjacent variable camber wing ribs. Each of the respective nose segments of the respective plurality of variable camber wings can be hingeably connected to an adjacent first linkage, and each of the respective second linkages of the respective plurality of variable camber wings can be hingeably connected to an adjacent first linkage.

[0016] The second linkage can define a top surface and a bottom surface, where the top and bottom surfaces taper toward each other from the third hinge aperture to the second clevis.

[0017] The wing can have at least one additional linkage, configured to hingeably connect with an adjacent linkage.

[0018] In another aspect, a variable camber wing for mounting to a vehicle chassis can have a nose segment defining a proximal leading edge and a distal edge. The nose segment can have a channel therethrough between the proximal leading edge and the distal edge, an arcuate aperture therethrough aft of the channel, and a second aperture therethrough aft of the arcuate

aperture. The nose segment can have a head formed at the distal edge.

[0019] The wing can have a first linkage defining a clevis on a proximal end and a distal end aft of the proximal end. The first linkage can be configured to hingeably connect to the nose segment, wherein the clevis overlaps the arcuate aperture. The wing can have a second linkage defining a second clevis on a proximal end and a trailing distal edge. The second linkage can be configured to hingeably connect to the first linkage, wherein the second clevis is complementarily configured to rotatably engage with the head of the nose segment.

[0020] The wing can have an actuator shaft extending from the vehicle chassis through the channel and capable of angular rotation about an axis of the actuator shaft; and a static pin affixed to the vehicle chassis and extending through the arcuate aperture, wherein the clevis is complementarily configured to rotatably engage with the static pin.

[0021] The first linkage can have a first hinge aperture therethrough aft of the clevis and configured to be aligned axially with the second aperture of the nose segment wherein the first linkage is hingeably connected to the nose segment when a pin is inserted through the first hinge aperture and the second aperture.

[0022] The first linkage can have a second hinge aperture therethrough aft of the first hinge aperture, and the second linkage having a third hinge aperture therethrough aft of the second clevis. The third hinge aperture can be configured to align axially with the second hinge aperture of the first linkage wherein the first linkage is hingeably connected to the second linkage when a second pin is inserted through the aligned second and third hinge apertures.

[0023] The nose segment, the first linkage, and the second linkage can define a first variable camber wing rib, wherein the variable camber wing comprises a plurality of adjacent variable camber wing ribs. Each of the respective nose segments of the respective plurality of variable camber wings can be hingeably connected to an adjacent first linkage, and each of the respective second linkages of the respective plurality of variable camber wings can be hingeably connected to an adjacent first linkage.

[0024] The second linkage can define a top surface and a bottom surface, wherein the top and bottom surfaces taper toward each other from the third hinge aperture to the second clevis.

[0025] The wing can have a smooth elastomeric coating fixed to and extending over the nose segment, the first linkage and the second linkage.

[0026] The wing can have at least one additional linkage, configured to hingeably connect with an adjacent linkage.

[0027] Also disclosed are associated methods for making a variable camber segmented wing.

[0028] The foregoing and other features and advantages will become more apparent from the following detailed description, which proceeds with reference to the accompanying drawings.

BRIEF DESCRIPTION OF THE DRAWINGS

[0029] Referring to the drawings, wherein like numerals refer to like parts throughout the several views and this specification, aspects of presently disclosed principles are illustrated by way of example, and not by way of limitation.

[0030] **FIG. 1A** illustrates a partially cutaway view of a variable camber segmented wing.

[0031] **FIG. 1B** illustrates an exploded view of the variable camber segmented wing.

[0032] **FIGS. 2A, 2B,** and **2C** illustrate the variable camber segmented wing at different actuation angles.

[0033] **FIG. 3** shows a cross-sectional view taken along a plane represented by section line III-III shown in **FIG. 2A**.

[0034] **FIG. 4** shows an isometric view of a variable camber segmented wing in an unactuated configuration.

[0035] FIG. 5 shows an isometric view of the variable camber segmented wing in an actuated configuration.

[0036] FIG. 6 shows a graph of the lift of an airfoil, and a performance gain, as a function of angle of attack.

DETAILED DESCRIPTION OF THE INVENTION

[0037] The following describes various principles related to variable camber segmented control surfaces. For example, certain aspects of disclosed principles pertain to assemblies of segmented levers configured to articulate in both positive and negative symmetric cambers by means of a single degree of freedom rotary actuation shaft, without the need for secondary actuators. That said, descriptions herein of specific apparatus configurations and combinations of method acts are but particular examples of contemplated systems chosen as being convenient illustrative examples of disclosed principles. One or more of the disclosed principles can be incorporated in various other systems to achieve any of a variety of corresponding system characteristics.

[0038] Thus, systems having attributes that are different from those specific examples discussed herein can embody one or more presently disclosed principles, and can be used in applications not described herein in detail. Accordingly, such

alternative embodiments also fall within the scope of this disclosure.

[0039] Conventionally, improving control at lower speeds in wing design has led to larger control surfaces. However, larger control surfaces typically create more drag at higher speed. Some wings are made with flaps that may be temporarily extended and/or angled to increase the control surface and/or modify the camber when needed, e.g., at slower speeds. These flap systems are complex mechanically and electrically, and thus may be more expensive to use and maintain. These flap systems may be more subject to mechanical failure and/or control system errors.

[0040] Accordingly, an approach to a variable camber wing that is relatively simpler and provides a relatively more adjustable camber and improved lift is needed. The principles disclosed herein overcome many problems in the prior art and address one or more of the aforementioned or other needs.

[0041] Further details of disclosed principles are set forth below. Section II describes principles pertaining to a segmented airfoil whose camber can be varied with a single actuator. Section III describes principles pertaining to improvements in lift provided by the disclosed embodiments.

[0042] The following description and related figures are presented in context of a symmetric wing, but following a review of this disclosure, a person of ordinary skill in the art will

readily appreciate that principles disclosed herein can be adapted for other control surface configurations (e.g., non-symmetrical control surfaces) whose camber may be varied both positively and negatively with a single rotary actuation shaft by means of a plurality of hingeably interconnected segments of the control surface. A single actuator shaft can rotate one segment, and by virtue of the hingeable connections among the plural segments, adjust the camber of the wing. Although the discussion references airfoils and wings, the disclosed principles and constructs may also apply to hydrofoils and fins or other control surfaces configured to move through a fluid.

[0043] **FIG. 1A** shows a partial cutaway view of a variable camber wing **100** with a cover **101** partially removed to reveal internal components of the wing. The wing **100** that may be singularly actuated through a rotary shaft to provide bi-directional variable camber. Cover **101** is a pre-stretched elastomeric material. This can be made from a variety of resilient materials known in the art. **FIG. 1B** shows an exploded view of the wing **100** showing each of several segments, as well as a pedestal **102** to which the wing **100** mounts. Pedestal **102** can function to separate the variable camber wing **100** from a vehicle chassis or a static wing portion. The wing **100** may include three segments, for example, a nose section **110**, a first linkage **120**, and a second linkage **130**.

[0044] The wing **100** may be configured to be installed onto the pedestal **102** on a vehicle chassis. The pedestal **102** may include an actuator shaft **104** extending orthogonally from the pedestal and a static pin **106** extending orthogonally from the pedestal.

[0045] The nose segment **110** may define a proximal leading edge **112** and a distal edge at a head **119**. The leading edge **112** is defined as the point on the front of the airfoil having maximum curvature. The nose segment **110** may include a channel **114** disposed between the proximal edge and the distal edge. The channel **114** may extend spanwise through the nose segment **110** and may receive the actuator shaft **104** therethrough when the wing **100** is installed on the pedestal **102**. The shaft **104** may have splines and the channel **114** may have complementary splines that mate with the splines on the shaft **104** when the shaft extends through the channel. The mated splines can inhibit relative rotation between the shaft **104** and the nose segment **110**, allowing the shaft **104** to rotate the nose segment **110** as the shaft **104** rotates.

[0046] The nose segment **110** may include an arcuate aperture **116** aft of the channel **114** (e.g., between the channel **114** and the head **119**). The arcuate aperture **116** may extend spanwise through the nose segment and extend generally transversely relative to the nose segment. The arcuate aperture **116** may

receive the static pin **106** therethrough, when the wing **100** is installed on the pedestal **102**. When so installed, the actuator shaft **104** may be configured to rotate the nose section **110** with respect to the chassis surface. The rotation may change the angle of attack of the nose segment **110**, and of the wing **100**, and the arcuate aperture **116** can allow the nose segment **110** to rotate without binding on the static pin **106**.

[0047] The nose segment **110** may include a hinge aperture **117** between the arcuate aperture **116** and the head **119**, which may form part of a hinge connector.

[0048] The linkage **120** may define a clevis **122** on a proximal end. The linkage **120** may define a distal end **128** aft of the clevis **122**. The linkage **120** may include a hinge connector configured to hingeably connect the linkage to the nose segment. For example, the linkage **120** may include a first hinge aperture **124** aft of the clevis. The hinge connector may comprise the first hinge aperture **124** axially aligned with the hinge aperture **117** of the nose segment and a pin **118** inserted through the aligned apertures to hingeably connect the first linkage **120** to the nose segment **110** with the apertures **117** and **124** in spanwise alignment with the pin **118** extending through the aligned apertures. When so hingeably connected, the clevis **122**, which overlaps the arcuate aperture **116** and is complementarily configured relative to the static pin **106**, can rotatably engage

with the static pin **106** extending through the arcuate aperture **116**. Thus, as the shaft **104** rotates, the nose segment **110** also will rotate, causing the aperture **117** to swing through a first arc. As the aperture **124** is hingeably connected with the aperture **117** by the pin **118**, the aperture **124** will swing through the same arc as the aperture **117** by virtue of the shaft **114** rotating. However, the clevis **122**, which is hingeably connected with the static pin **106**, imparts a restraining force to a proximal end of the first linkage **120** as the aperture **124** swings through an arc. Consequently, the first linkage **120** will rotate relative to the nose segment **110**. The linkage **120** may also include a second hinge aperture **125** aft of the first hinge aperture **124**.

[0049] The second linkage **130** may define a second clevis **132** on a proximal end, together with a trailing distal edge **138**. The trailing edge of an airfoil is defined as the point of maximum curvature on the rear end of the airfoil. The linkage **130** may include a second hinge connector configured to hingeably connect the second linkage **130** to the first linkage **120**. For example, the linkage **130** may include a third hinge aperture **134**. The hinge connector may comprise the third hinge aperture **134** axially aligned with the second hinge aperture **125** of the linkage **120** and a pin **126** inserted through the aligned apertures to hingeably connect the second linkage **130** to the first linkage

120. When so hingeably connected, the second clevis **132** may be complementarily configured to rotatably engage with the head **119** of the nose segment.

[0050] Although two linkages are described and shown in **FIG. 1B**, additional linkages can be added using the same type of hinge and clevis connections as the first linkage and the second linkage.

[0051] The illustrated arrangement of the nose segment **110** and the linkages **120, 130** permits the effective camber of the control surface of the wing **100** to be altered as the nose segment **110** is angularly displaced by the rotation of the actuator shaft **104**.

[0052] **FIGS. 2A-2C** illustrate the wing **100** at different actuation angles, resulting in different cambers and angles of attack. **FIG. 2A** shows the wing **100** in an unactuated configuration, e.g., at an actuation angle of zero, and at a zero attack angle. In this context, "unactuated" means that the nose segment **110** is not rotated with respect to the pedestal. An airfoil defines a chord line, which is the straight line between the leading edge and the trailing edge. A mean camber line of an airfoil is defined as the locus of points midway between the upper and lower surfaces. In the unactuated configuration, the wing **100** may be symmetrical, in the sense that the mean camber line and the chord line are the same line, shown as line **202**,

and that the shape of the airfoil above the chord mirrors the shape of the airfoil below the chord.

[0053] **FIG. 2B** shows the wing **100** at a first actuation angle x relative to the pedestal **102**. The actuator shaft **104** has caused the nose segment **110** to rotate about the actuator shaft **104**. The arcuate aperture **114** allows the nose segment **110** to move relative to the static pin **106**, such that the static pin **106** extends through the lower part of the arcuate aperture **116**. The clevis **122** of the first linkage **120** rotates about the static pin **106**, and the hinged connection at pin **118** allows the angle y of the linkage **120** relative to the nose segment **110** to change.

[0054] The clevis **132** of the second linkage **130** rotates about the head **119** of the nose segment **110**. The hinged connection at pin **126** allows the angle z of the second linkage **130** relative to the first linkage **120** to change. The head **119** may extend aftward by a neck that is narrower than a diameter of the head. The narrower width of the neck may allow the ends of the clevis to pivot more fully about the head, thereby permitting further deflection of the second linkage relative to the first linkage.

[0055] The proximal end of the second linkage **130**, e.g., the top and bottom surfaces extending between the clevis **132** and the aperture **134**, may be tapered toward the clevis such that, when the second linkage is angled away from the first linkage, the

tapered surfaces do not protrude above the top surface or below the bottom surface of the first linkage.

[0056] FIG. 2C shows the wing **100** at a different actuation angle x' of the nose segment **110** relative to the pedestal **102**. The change in the actuation angle causes the angle of the linkage **120** relative to the nose segment **110** to change to angle y' . The change to the angles and in turn causes the angle of the second linkage **130** relative to the first linkage **120** to change to the angle z' .

[0057] Of note is that the chord line of the airfoil has changed relative to the unactuated airfoil, seen as line **202'**. Because the camber has changed, the mean camber line **204** has also changed relative to the mean camber line of the unactuated airfoil. The mean camber line **204** does not align with the chord line **202'**.

[0058] Although only three different actuation angles are illustrated herein, the wing **100** may be actuated to any angle in a range of angles relative to the pedestal between $\pm 90^\circ$, such as, for example, $\pm 3^\circ$, $\pm 6^\circ$, $\pm 8^\circ$, $\pm 10^\circ$, $\pm 15^\circ$, $\pm 25^\circ$, $\pm 30^\circ$, or $\pm 45^\circ$.

[0059] Two linkages are shown in relation to the nose segment, however, the number and position of the segments can be varied as needed. A higher number of linkages may provide a smoother piecewise linear fit to a theoretically smooth cambered airfoil. Additionally, a pre-stretched smooth elastomeric

coating may be fixed to each segment and linkage outside the hinged regions to minimize flow disturbances and therefore increase lift performance and minimize drag.

[0060] In an embodiment, a nose segment **110**, a first linkage **120**, and a second linkage **130** may define a variable camber wing rib. A plurality of variable camber wing ribs may be interleaved to form a wider control surface for a wing as illustrated in **FIG. 3**. **FIG. 3** shows a cross-sectional view of the interleaved components taken along a plane represented by section line III-III shown in **FIG. 2A**. The scale of the components in the figure is exaggerated for clarity. A variable camber rib **301** may be defined, for example, by a nose segment **110-a**, a first linkage **120-a**, and second linkage **130-a**. The second linkage **130-a** may be positioned linearly directly aft of the nose segment **110-a** such that the clevis **132** of the second linkage **130-a** engages with the head **119** of the nose segment **110-a**.

[0061] The first linkage **120-a** may be positioned parallel and adjacent to the second linkage **130-a** and the nose segment **130-a** in a spanwise direction. The first linkage **120-a** may be positioned such that the clevis **122** may engage with the static pin **106** when the static pin **106** is present within the aperture **116**. The aperture **124** of the first linkage **120-a** may be axially aligned with the aperture **117** of the nose segment **110-a** such that the pin **118** may be placed therethrough. The aperture **125** of

the first linkage **120-a** may be axially aligned with the aperture **134** of the second linkage **130-a** such that the pin **126** may be inserted therethrough.

[0062] The arrangement may be repeated, for example, with another variable camber wing rib **302**, defined by a nose segment **110-b**, a first linkage **120-b**, and a second linkage **130-b**. The nose segment **110-b** and second linkage **130-b** may be parallel and adjacent to the first linkage **120-a**, and the first linkage **120-b** may be parallel and adjacent to the nose segment **110-b** and second linkage **130-b**. The arrangement may be repeated still further to obtain a desired span for the control surface of the wing.

[0063] For example, **FIGS. 4** and **5** show an isometric view of a wing **300** having a plurality of nose segments **110**, first linkages **120** and second linkages **130** in an interleaved arrangement as shown in **FIG. 3**. **FIG. 4** shows the wing **300** in an unactuated configuration. **FIG. 5** shows the wing **300** in an actuated configuration. Part of the outer surface of outermost nose segment **110** is cutaway to show, namely, the actuator shaft **104** extending into the aperture **114** in the nose segment **110**, the static pin **106** extending through the arcuate aperture **116**. The nose segment **110** also includes the aperture **117** aft of the arcuate aperture **116** to receive a pin.

[0064] FIG. 6 shows a graph that illustrates the lift of an airfoil, and a performance gain, as a function of angle of attack for four known National Advisory Committee for Aeronautics (NACA) airfoils, and for an embodiment of the wing described above. The graph also illustrates a performance gain of wing over an angled symmetric airfoil, e.g., a NACA 0012 airfoil.

[0065] Table 1 below illustrates an expected lift improvement for an embodiment of the disclosed wing compared to an angled symmetric airfoil.

[0066] TABLE 1

Angle of Attack (deg)	Theoretical Improved lift over angled symmetric airfoil
-15.00	26%
-12.00	37%
-9.00	56%
-6.00	63%
-3.00	86%
3.00	86%
6.00	63%
9.00	56%
12.00	37%
15.00	26%

[0067] The examples described above generally concern apparatus, methods, and related systems for variable camber segmented control surfaces. More particularly, but not exclusively, disclosed principles pertain to systems, methods,

and components that use segmented levers assembled to articulate in both positive and negative symmetric cambers by means of a single degree of freedom rotary actuation shaft.

[0068] Nonetheless, the previous description is provided to enable a person skilled in the art to make or use the disclosed principles. Embodiments other than those described above in detail are contemplated based on the principles disclosed herein, together with any attendant changes in configurations of the respective apparatus or changes in order of method acts described herein, without departing from the spirit or scope of this disclosure. Various modifications to the examples described herein will be readily apparent to those skilled in the art.

[0069] For example, the linkages may define different shapes than those described, provided that in an assembled configuration, an airfoil is still defined. The hinged connector may include any configuration that permits a hinged relationship between two adjacent components.

[0070] Directions and other relative references (e.g., up, down, top, bottom, left, right, rearward, forward, etc.) may be used to facilitate discussion of the drawings and principles herein, but are not intended to be limiting. For example, certain terms may be used such as "up," "down," "upper," "lower," "horizontal," "vertical," "left," "right," and the like. Such terms are used, where applicable, to provide some

clarity of description when dealing with relative relationships, particularly with respect to the illustrated embodiments. Such terms are not, however, intended to imply absolute relationships, positions, and/or orientations. For example, with respect to an object, an "upper" surface can become a "lower" surface simply by turning the object over. Nevertheless, it is still the same surface and the object remains the same. As used herein, "and/or" means "and" or "or", as well as "and" and "or." Moreover, all patent and non-patent literature cited herein is hereby incorporated by reference in its entirety for all purposes.

[0071] And, those of ordinary skill in the art will appreciate that the exemplary embodiments disclosed herein can be adapted to various configurations and/or uses without departing from the disclosed principles. Applying the principles disclosed herein, it is possible to provide a wide variety of variable camber segmented control surfaces and related methods and systems to increase control authority at slower speeds while maintaining minimal drag at higher speeds. For example, the principles described above in connection with any particular example can be combined with the principles described in connection with another example described herein. Thus, all structural and functional equivalents to the features and method acts of the various embodiments described throughout the

disclosure that are known or later come to be known to those of ordinary skill in the art are intended to be encompassed by the principles described and the features and acts claimed herein. Accordingly, neither the claims nor this detailed description shall be construed in a limiting sense, and following a review of this disclosure, those of ordinary skill in the art will appreciate the wide variety of variable camber segmented control surfaces and related methods and systems that can be devised using the various concepts described herein.

[0072] Moreover, nothing disclosed herein is intended to be dedicated to the public regardless of whether such disclosure is explicitly recited in the claims. No claim feature is to be construed under the provisions of 35 USC 112(f), unless the feature is expressly recited using the phrase "means for" or "step for".

[0073] The appended claims are not intended to be limited to the embodiments shown herein, but are to be accorded the full scope consistent with the language of the claims, wherein reference to a feature in the singular, such as by use of the article "a" or "an" is not intended to mean "one and only one" unless specifically so stated, but rather "one or more". Further, in view of the many possible embodiments to which the disclosed principles can be applied, we reserve the right to claim any and all combinations of features and technologies

described herein as understood by a person of ordinary skill in the art, including the right to claim, for example, all that comes within the scope and spirit of the foregoing description, as well as the combinations recited, literally and equivalently, in any claims presented anytime throughout prosecution of this application or any application claiming benefit of or priority from this application, and more particularly but not exclusively in the claims appended hereto.

VARIABLE CAMBER SEGMENTED CONTROL SURFACE ASSEMBLY

ABSTRACT OF THE DISCLOSURE

A variable camber wing for mounting to a vehicle chassis has an actuator shaft and a static pin extending from the chassis. The wing's nose segment defines a proximal edge and a distal edge and has a channel therethrough between the proximal and distal edges, an arcuate aperture therethrough aft of the channel, and a second aperture therethrough aft of the arcuate aperture. The wing has a first linkage defining a clevis on a proximal end and hingeably connected to the nose segment. The clevis can rotatably engage with the static pin extending through the arcuate aperture. A second linkage defines a second clevis on a proximal end and a distal edge. The second linkage is configured to hingeably connect to the first linkage.

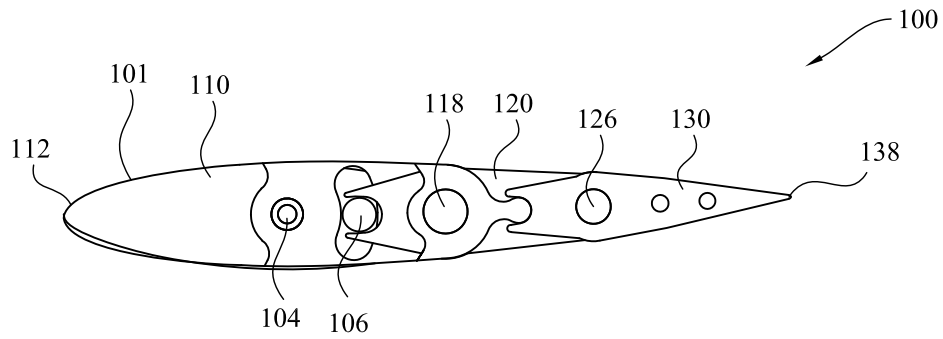

FIG. 1A

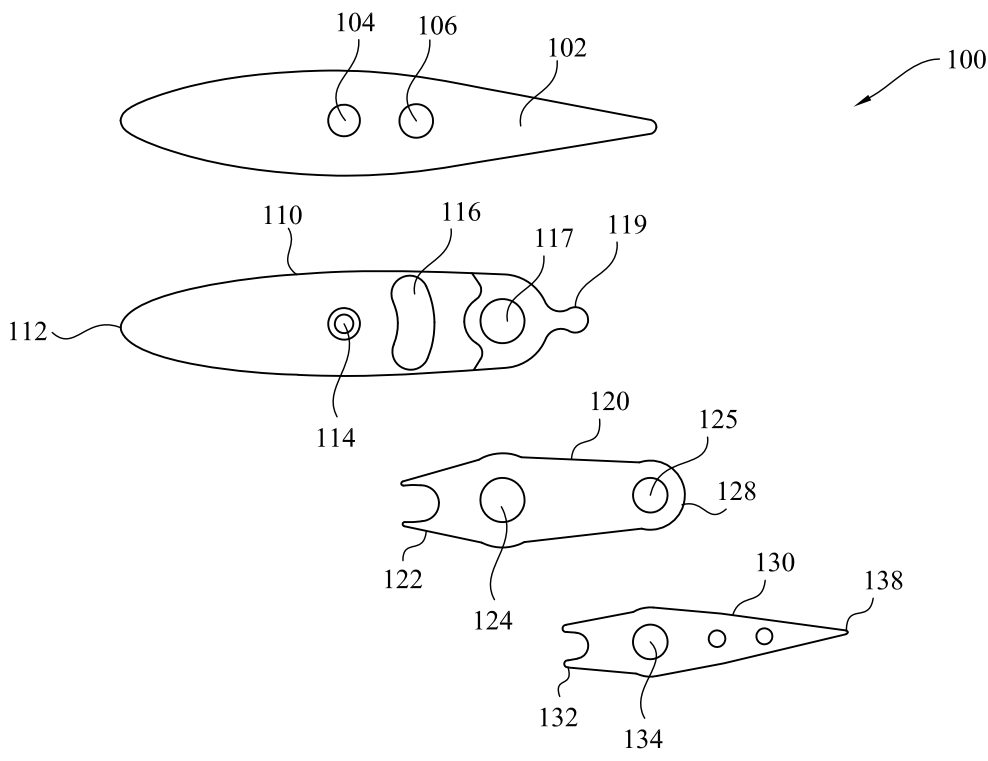

FIG. 1B

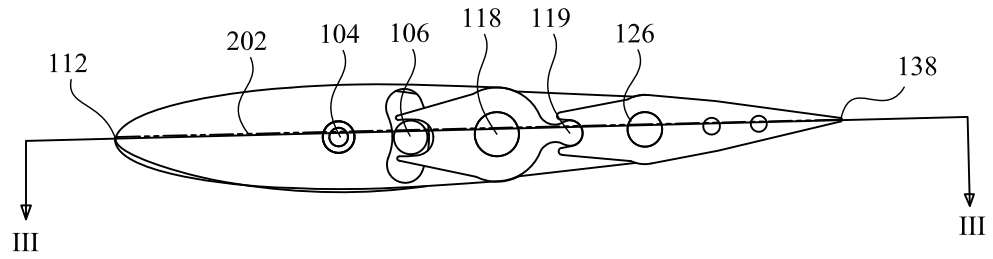

FIG. 2A

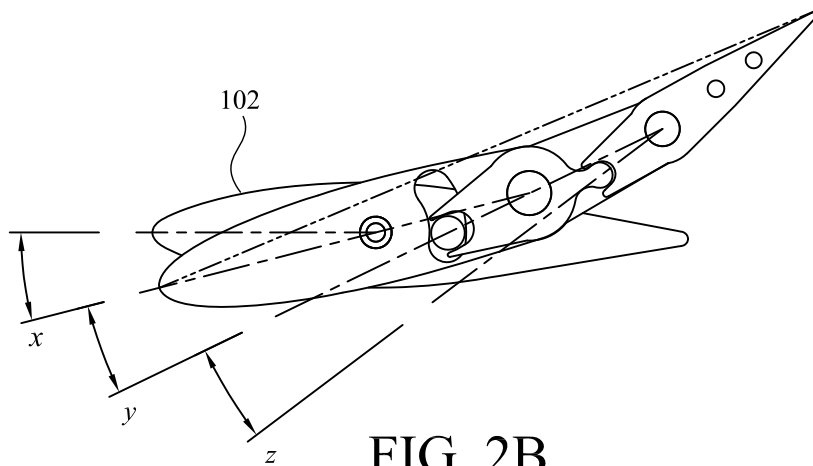

FIG. 2B

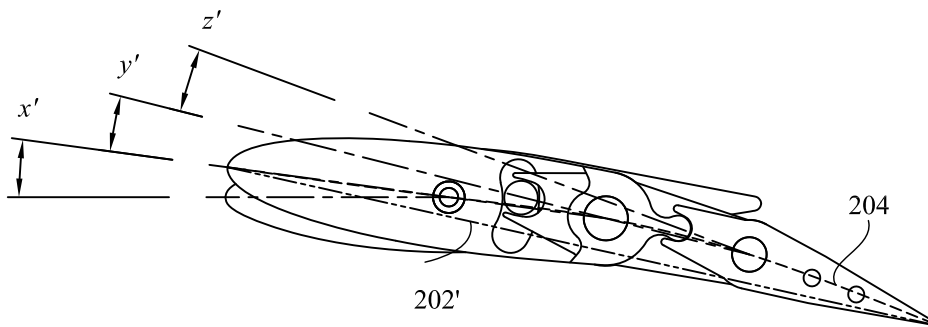

FIG. 2C

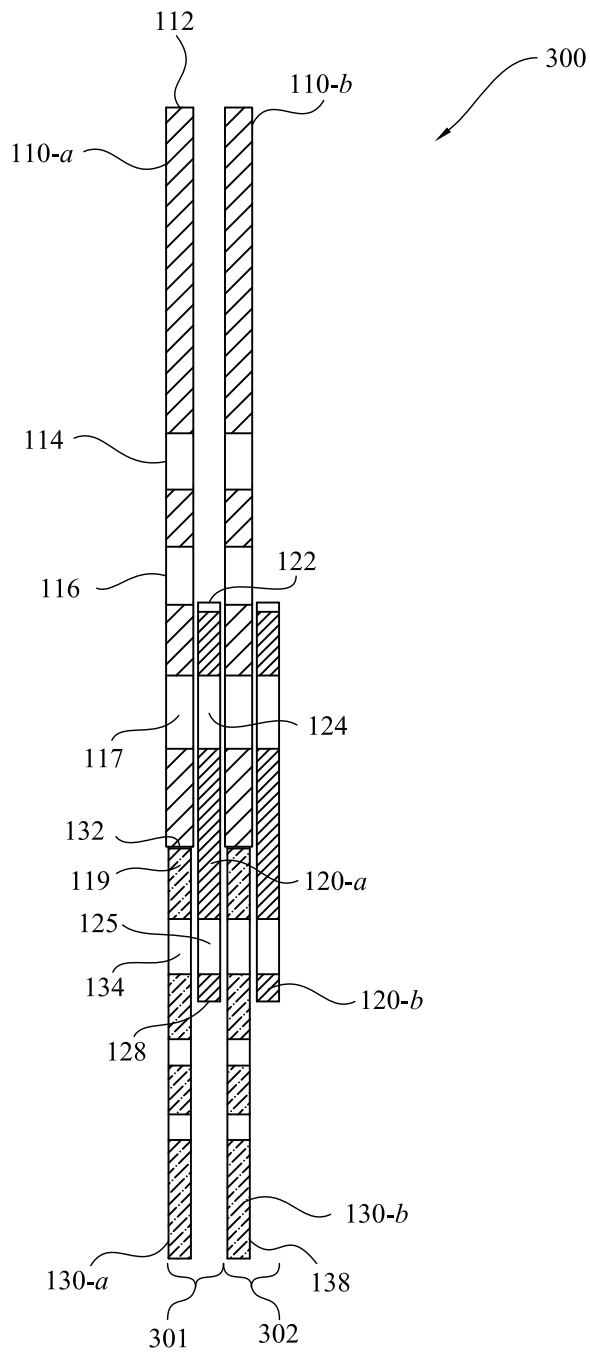

FIG. 3

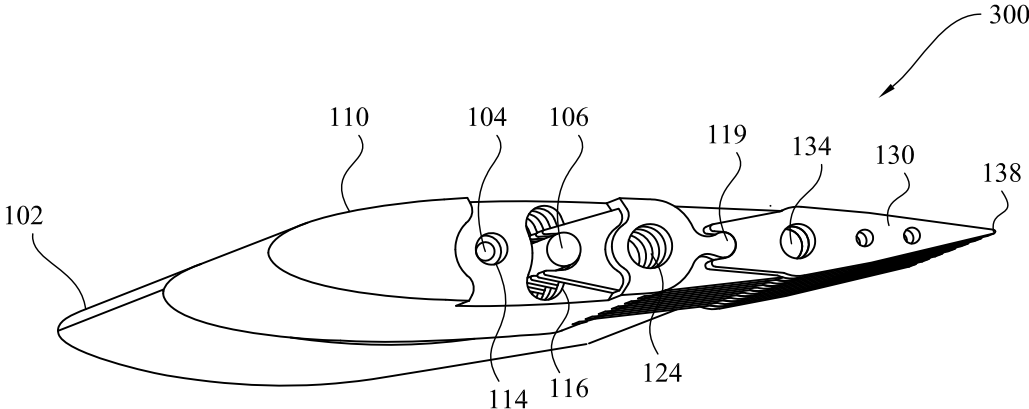

FIG. 4

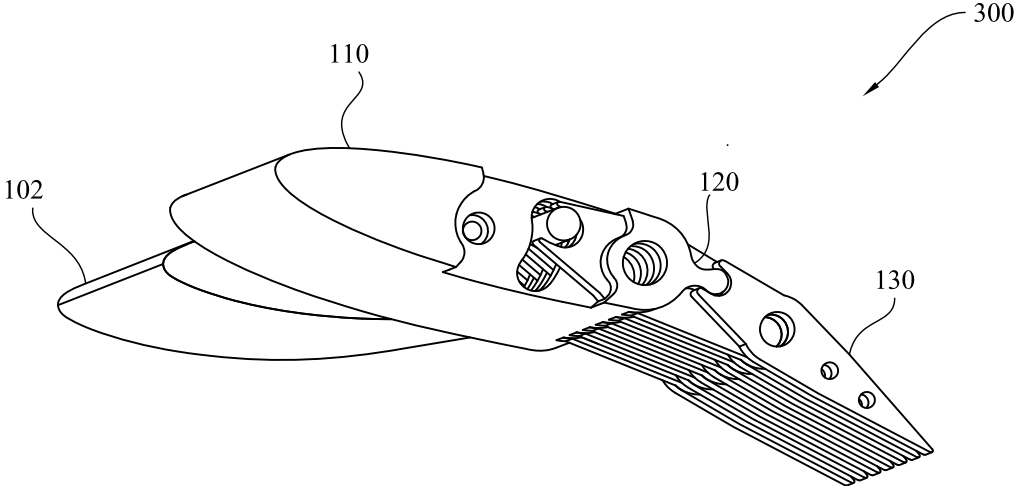

FIG. 5

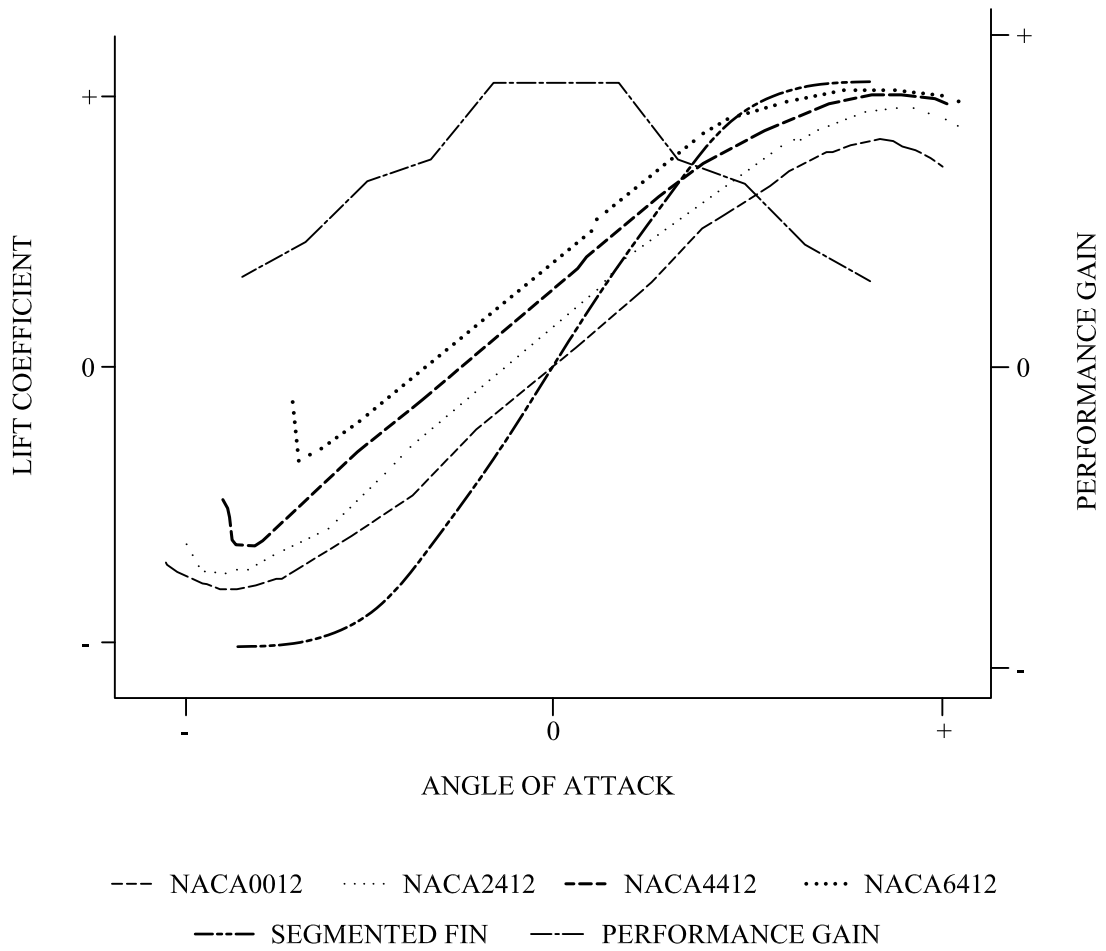

FIG. 6