



NAVAL POSTGRADUATE SCHOOL

MONTEREY, CALIFORNIA

MBA PROFESSIONAL PROJECT

AN INTERNET OF THINGS–BASED APPROACH TO INNOVATE CANTEEN STORES DEPARTMENT’S RETAIL OPERATIONS

June 2022

By: **Sohaib Leghari**
 Kashif Kamal
 Hafiz K. Rashid

Advisor: **Robert F. Mortlock**
Second Reader: **Raymond D. Jones**

Approved for public release. Distribution is unlimited.

THIS PAGE INTENTIONALLY LEFT BLANK

REPORT DOCUMENTATION PAGE			<i>Form Approved OMB No. 0704-0188</i>
Public reporting burden for this collection of information is estimated to average 1 hour per response, including the time for reviewing instruction, searching existing data sources, gathering and maintaining the data needed, and completing and reviewing the collection of information. Send comments regarding this burden estimate or any other aspect of this collection of information, including suggestions for reducing this burden, to Washington headquarters Services, Directorate for Information Operations and Reports, 1215 Jefferson Davis Highway, Suite 1204, Arlington, VA 22202-4302, and to the Office of Management and Budget, Paperwork Reduction Project (0704-0188) Washington, DC 20503.			
1. AGENCY USE ONLY (Leave blank)	2. REPORT DATE June 2022	3. REPORT TYPE AND DATES COVERED MBA Professional Project	
4. TITLE AND SUBTITLE AN INTERNET OF THINGS–BASED APPROACH TO INNOVATE CANTEEN STORES DEPARTMENT’S RETAIL OPERATIONS		5. FUNDING NUMBERS	
6. AUTHOR(S) Sohaib Leghari, Kashif Kamal, and Hafiz K. Rashid			
7. PERFORMING ORGANIZATION NAME(S) AND ADDRESS(ES) Naval Postgraduate School Monterey, CA 93943-5000		8. PERFORMING ORGANIZATION REPORT NUMBER	
9. SPONSORING / MONITORING AGENCY NAME(S) AND ADDRESS(ES) N/A		10. SPONSORING / MONITORING AGENCY REPORT NUMBER	
11. SUPPLEMENTARY NOTES The views expressed in this thesis are those of the author and do not reflect the official policy or position of the Department of Defense or the U.S. Government.			
12a. DISTRIBUTION / AVAILABILITY STATEMENT Approved for public release. Distribution is unlimited.		12b. DISTRIBUTION CODE A	
13. ABSTRACT (maximum 200 words) In a competitive business environment, retail organizations in the Western world are capitalizing on technological tools and solutions to enhance customer experience and boost sales. Specifically, retailers that adopt Internet of Things (IoT) technologies improve customer experience and achieve cost savings. Yet such innovation is rare outside the Western world. Hence, early adopters of IoT technologies in retail operations in Pakistan could gain a competitive advantage. This study aims to create a deeper understanding of how Pakistan-based Canteen Stores Department (CSD), a retail chain mainly serving service members and their families, can use IoT technologies to significantly modernize and improve its operations and distinguish itself from competitors. To do so, this study conducts a qualitative analysis of scholarly articles on the relevant technologies and on IoT-based products offered by commercial companies. The authors also include findings from discussions with CSD customers and management. The results of the study indicate CSD can use IoT technologies to optimize store layout, offer interactive in-store mapping, automate checkout systems, implement smart shelving and digital price tagging, improve in-store promotions, enhance customer relationship management, and modernize distribution, transportation, and warehousing. The study also offers CSD management guidance on how to implement IoT technologies into retail operations at one location as a pilot.			
14. SUBJECT TERMS IoT, retail operations, Pakistan’s retail industry, technology-based retail solutions, digital information gathering, retail automation		15. NUMBER OF PAGES 111	
		16. PRICE CODE	
17. SECURITY CLASSIFICATION OF REPORT Unclassified	18. SECURITY CLASSIFICATION OF THIS PAGE Unclassified	19. SECURITY CLASSIFICATION OF ABSTRACT Unclassified	20. LIMITATION OF ABSTRACT UU

THIS PAGE INTENTIONALLY LEFT BLANK

Approved for public release. Distribution is unlimited.

**AN INTERNET OF THINGS–BASED APPROACH TO INNOVATE CANTEEN
STORES DEPARTMENT’S RETAIL OPERATIONS**

Sohaib Leghari, Lieutenant Commander, Pakistan Navy
Kashif Kamal, Wing Commander, Pakistan Air Force
Hafiz K. Rashid, Lieutenant Colonel, Pakistan Army

Submitted in partial fulfillment of the
requirements for the degree of

MASTER OF BUSINESS ADMINISTRATION

from the

**NAVAL POSTGRADUATE SCHOOL
June 2022**

Approved by: Robert F. Mortlock
Advisor

Raymond D. Jones
Second Reader

Amilcar A. Menichini
Academic Associate, Department of Defense Management

Bryan J. Hudgens
Academic Associate, Department of Defense Management

Robert F. Mortlock
Academic Associate, Department of Defense Management

THIS PAGE INTENTIONALLY LEFT BLANK

AN INTERNET OF THINGS–BASED APPROACH TO INNOVATE CANTEEN STORES DEPARTMENT’S RETAIL OPERATIONS

ABSTRACT

In a competitive business environment, retail organizations in the Western world are capitalizing on technological tools and solutions to enhance customer experience and boost sales. Specifically, retailers that adopt Internet of Things (IoT) technologies improve customer experience and achieve cost savings. Yet such innovation is rare outside the Western world. Hence, early adopters of IoT technologies in retail operations in Pakistan could gain a competitive advantage. This study aims to create a deeper understanding of how Pakistan-based Canteen Stores Department (CSD), a retail chain mainly serving service members and their families, can use IoT technologies to significantly modernize and improve its operations and distinguish itself from competitors. To do so, this study conducts a qualitative analysis of scholarly articles on the relevant technologies and on IoT-based products offered by commercial companies. The authors also include findings from discussions with CSD customers and management. The results of the study indicate CSD can use IoT technologies to optimize store layout, offer interactive in-store mapping, automate checkout systems, implement smart shelving and digital price tagging, improve in-store promotions, enhance customer relationship management, and modernize distribution, transportation, and warehousing. The study also offers CSD management guidance on how to implement IoT technologies into retail operations at one location as a pilot.

THIS PAGE INTENTIONALLY LEFT BLANK

TABLE OF CONTENTS

I.	INTRODUCTION.....	1
A.	PROBLEM STATEMENT	2
B.	RESEARCH QUESTIONS.....	2
C.	RESEARCH OBJECTIVES.....	3
D.	SCOPE OF THE RESEARCH PROJECT	3
E.	RESEARCH LIMITATIONS.....	4
F.	RESEARCH METHODOLOGY	5
G.	SIGNIFICANCE OF THE STUDY	6
H.	CHAPTER OUTLINES	6
II.	BACKGROUND	9
A.	CSD EXTERNAL ENVIRONMENT – OVERVIEW OF PAKISTAN’S RETAIL INDUSTRY	9
	1. Categories of the Pakistani Retail Sector.....	9
	2. Emerging Trend in Pakistani Retail Sector.....	10
	3. CSD’s Positioning in the Pakistani Retail Sector.....	11
B.	OVERVIEW OF CSD’S RETAIL OPERATIONS.....	11
	1. CSD’s Customer Experience.....	11
	2. CSD’s Internal Retail Management.....	12
	3. CSD’s Supplier Relationship	14
C.	IOT-BASED RETAIL MARKET OPPORTUNITIES FOR CSD.....	14
III.	LITERATURE REVIEW	17
A.	DEFINITION OF IOT AND APPLICATIONS FOR IOT.....	17
	1. Hospitality Industry.....	18
	2. Health Care.....	18
	3. Education	19
	4. Freight and Logistics	19
	5. Application of IoT in Daily Life.....	20
B.	NEED TO INNOVATE RETAIL OPERATIONS	20
	1. Domains of Retail Innovation	21
	2. Innovative Technologies Driving Retail Transformation	22
C.	IOT-BASED RETAIL OPERATIONS AND THEIR ADVANTAGES.....	25
	1. IoT-Based Store Layout	26
	2. IoT-Based Automated Checkout	26
	3. IoT-Based Store Map.....	28

4.	IoT-Based Shelf Availability	29
5.	IoT-Based In-Store Promotions.....	30
6.	IoT-Based CRM	31
7.	IoT-Based Digital Shelf Tags	32
8.	Utilization of Augmented Reality	33
9.	IoT-Based Multimodal Distribution and Retailing.....	33
D.	IOT IMPLEMENTATION FRAMEWORK	34
1.	IoT Components.....	34
2.	IoT-Implemented Library System Utilizing RFID and WSN	38
3.	IoT Implementation Requirements	40
E.	CHALLENGES IN IMPLEMENTATION OF IOT TECHNOLOGIES.....	41
1.	Distributed Network	42
2.	Variability of IoT Applications.....	42
3.	Data Management.....	43
4.	Application Maintenance	43
5.	Human-Centric Interaction	43
6.	Inter-Dependency of Different Applications	44
7.	Stakeholder Concerns.....	44
8.	Quality Output Assurance	45
F.	INNOVATION IN THE PAKISTANI RETAIL SECTOR	45
IV.	FINDINGS AND ANALYSIS	47
A.	DOMAINS FOR INNOVATION IN CSD'S RETAIL OPERATIONS	47
1.	CSD's Retail Identity as a Brand	47
2.	CSD's Retail Physicality.....	48
B.	ANALYSIS OF IOT APPLICATIONS FOR ADOPTION AT CSD'S RETAIL OPERATIONS	48
1.	IoT-Based Store Layout	49
2.	Automated Checkout at CSD's Store.....	50
3.	IoT-Based Map of CSD's Store	53
4.	Smart Shelving at CSD's Store.....	55
5.	IoT-Based In-Store Promotion at CSD's Store.....	58
6.	Digital Price Tagging at CSD's Store.....	59
7.	Smart CRM at CSD's Store	61
8.	IoT-Based Distribution and Retailing for CSD.....	63
C.	INTEGRATION OF FEASIBLE IOT-BASED SOLUTIONS AT CSD.....	66

1.	Software	67
2.	Hardware	68
3.	Architecture.....	69
V.	CONCLUSION AND RECOMMENDATIONS.....	71
A.	RECOMMENDATIONS FOR MANAGEMENT TO ADDRESS POTENTIAL IMPLEMENTATION CHALLENGES	73
B.	RECOMMENDATIONS FOR FURTHER RESEARCH	75
	LIST OF REFERENCES.....	77
	INITIAL DISTRIBUTION LIST	91

THIS PAGE INTENTIONALLY LEFT BLANK

LIST OF FIGURES

Figure 1.	IoT Basic Architecture. Source: Bayani et al. (2018).....	36
Figure 2.	RFID-Based IoT Architecture. Source: Bayani et al. (2018).....	37
Figure 3.	WSN Architecture. Source: Bayani et al. (2018).....	38
Figure 4.	IoT-Based Library System. Source: Bayani et al. (2018).....	39

THIS PAGE INTENTIONALLY LEFT BLANK

LIST OF TABLES

Table 1. Existing IoT Applications. Adapted from Bok (2016).67

THIS PAGE INTENTIONALLY LEFT BLANK

LIST OF ACRONYMS AND ABBREVIATIONS

AI	artificial intelligence
AR	augmented reality
CAGR	compound annual growth rate
CRM	customer relationship management
CSD	Canteen Stores Department
DC	distribution center
ERP	enterprise resource planning
FMCG	fast-moving consumer goods
FY	Fiscal Year
GDP	gross domestic product
GPS	Global Positioning System
IoT	Internet of Things
IPS	indoor positioning system
IT	information technology
MoD	Ministry of Defense
OEM	original equipment manufacturer
OSA	on-shelf availability
PO	purchase order
POS	point of sales
QR	quick response
RFID	radio frequency identification
ROP	reorder point
SKU	stock-keeping unit
SME	subject matter expert
USP	unique selling proposition
WSN	wireless sensors network

THIS PAGE INTENTIONALLY LEFT BLANK

ACKNOWLEDGMENTS

We would like to take this opportunity to thank our research advisor, Professor Robert Mortlock, whose encouragement, support, and guidance from the very beginning to the last phase enabled us to develop an understanding of the subject and made this study possible. We would also like to thank our second reader, Professor Raymond Jones, for providing us valuable feedback on this study.

We express our gratitude to all those who contributed to this study directly or indirectly. We are grateful to the management of Canteen Stores Department (CSD) for providing us their feedback in understanding the CSD's retail operations. We would also like to thank our program manager, CDR Matthew Geiser, academic associates, and Naval Postgraduate School's Department of Defense faculty, Graduate Writing Center coaches, and Thesis Processing Office processors for their guidance, support, and academic instructions, which helped us in completing this study.

THIS PAGE INTENTIONALLY LEFT BLANK

I. INTRODUCTION

The Internet of Things (IoT) provides numerous technological tools and solutions that can enhance retail business operations (Bok, 2016). An overview of the retail industry will show that emerging technologies have made a huge impact by giving retailers a competitive advantage (Vel et al., 2010). In particular, the basic retail operation of matching demand and supply while keeping minimum inventories is cumbersome without the effective utilization of technological tools (Caro & Sadr, 2019). IoT can significantly improve such retail operations based on information gathering from multiple sources by utilizing technology (Bennett, 2017). Consumers themselves have rapidly adopted IoT, which is already widespread in households through products such as Amazon Alexa, Smart Homes, and autonomous cars (Grewal et al., 2018). By contrast, the utilization of IoT in retail's front-end operations is relatively low because retailers are usually adapters to new technology rather than innovators of new retail trends (Vel et al., 2010). Therefore, introducing IoT-based retail stores in a developing country like Pakistan poses a unique opportunity for retailers to capitalize on potential benefits and better serve customers.

Pakistan's retail sector has yet to see widescale adoption of emerging technology-based solutions to improve business offerings (Ali & Xie, 2021). The majority of the retail market consists of "mom-and-pop" shops with limited offerings (Ghani, 2005). There are few superstore chains, and they are usually established in big cities of Pakistan (Arshad, 2020). These big players of the Pakistani market have established their strong distribution channels, and due to their huge customer base and sales, they offer their products at much lower prices than the traditional local stores (Iqbal, Rahim et al., 2020). While the local stores are unable to compete with large supermarket chains on price, for example, they have one advantage: their accessibility to customers (Irfan et al., 2019). These local stores are located within residential areas, and therefore, customers prefer to buy grocery items from their locally owned stores instead of driving to supermarkets that are either far from the residential areas or at least at distances that could not be covered on foot. Furthermore, supermarkets in Pakistan usually attract shoppers from higher-income households, who tend to have cars and stable monthly income (Arshad, 2020). Given the increasing

importance of IoT just delineated and the Pakistani retail market, this research focuses on improving the retail operations of the Canteen Stores Department (CSD), a chain of superstores being managed by the Pakistani Ministry of Defense (MoD).

A. PROBLEM STATEMENT

CSD, one of the country's largest retail store chains, currently operates more than 100 stores in Pakistan (Canteen Stores Department [CSD] The Caring Store, n.d.). CSD is a self-sustaining government organization managed and supervised by the MoD. The primary aim of CSD is to provide a benefit to the armed forces personnel of Pakistan by offering high quality grocery and electronic items at much-discounted prices. Moreover, as per the researchers' discussion with CSD's managing director (personal communication, November 8, 2021), the chain also serves civilians by providing a diversified range of products under one roof at comparatively lower prices than other superstores. In order to sustain and compete in the retail business sector of Pakistan, CSD has committed to continuously improving its retail processes (CSD The Caring Store, n.d.). At the same time, to sustain its retail operations and be competitive in a retail market facing new challenges from online retailing, there is a need to analyze CSD's retail operations and thereby improve them through innovative technologies to remain competitive. Therefore, the researchers believe that the integration of new technologies into CSD's retail operation can lead to potential benefits of enhanced customer experience and more efficient retail operations that CSD's management should consider. Nonetheless, not all technological solutions are feasible for adoption. Therefore, this study has attempted to identify and suggest IoT-based processes and technologies that CSD can adopt in the Pakistani retail market and continue its mission of serving the nation by providing discounted products to armed forces personnel and citizens of Pakistan.

B. RESEARCH QUESTIONS

The primary research goal of the study is to identify available IoT-based technologies and processes feasible for implementation in the retail setup of CSD. To accomplish this goal, the study considers the following research questions:

1. What is CSD's retail operation?

2. What are the most effective IoT-based technologies available for the retail industry?
3. What IoT-based technologies can feasibly be implemented into CSD's retail operation?
4. What are the potential benefits and issues associated with innovating CSD's retail operations?

C. RESEARCH OBJECTIVES

The following research objectives have guided this research:

1. To explain the CSD's existing retail operations.
2. To study IoT-based technologies currently in use in the retail industry.
3. To determine the impact of adopting IoT in the retail operations of CSD.
4. To identify key processes in CSD's retail operation where IoT-based technologies can be implemented.
5. To determine potential benefits and issues associated with adopting IoT-based solutions in CSD's retail operations.

D. SCOPE OF THE RESEARCH PROJECT

Emerging technologies have created a wide range of solutions for the retail industry (Stubbs, 2016). The feasibility of implementing technology-based solutions in any business relies on several factors like IT infrastructure, internet connectivity, human resources, etc. (Grewal et al., 2018). These factors are dependent upon the internal and external environment of the organization (Vel et al., 2010). Especially in the retail sector, if the environment is not suitable for the adoption of technology, the perceived benefits might result in extra costs with no value creation (Paredes, 2015). It is imperative, therefore, to ascertain whether IoT-based solutions could be applicable in the retail sector of Pakistan and ultimately create value for retail customers. This research contains an analysis of various technologies falling under the umbrella of IoT; however, the focus is on the suitable technological solutions that would improve the retail operations of CSD and are feasible to

implement in the Pakistani retail setup. The study does not present a quantitative analysis to discuss the IoT implementation in terms of total costs of implementation and expected profits in numbers, but rather highlights the potential benefits based on the secondary data.

Several operations and strategies are adopted in a retail setup to provide better services to the customers. Some of these operations and strategies are value-driven and need greater emphasis for the overall improvement of a retail store. Therefore, the scope of this research is limited to the value-driven technological solutions encompassing store layout, automated checkout, store mapping, smart shelves, smart customer relationship management (CRM), digital price tagging, and robot-based warehousing and distribution. Although the study does not examine the engineering parameters of implementation in detail, the study does provide an analysis of IoT implementation issues arising from engineering, cultural, and social factors.

As mentioned earlier, CSD operates more than 100 outlets in Pakistan (CSD The Caring Store, n.d.). According to the managing director of CSD (personal communication, November 8, 2021), each outlet has different levels of resources and infrastructure; therefore, technological solutions in innovating CSD's retail operation might not be beneficial for all outlets. Moreover, as regular customers of CSD, the researchers have observed that CSD has diverse product offerings, ranging from electric appliances and automobiles to grocery items. Accordingly, the scope of this research is limited to grocery items and fast-moving consumer goods (FMCG) only.

Further, the research focuses on the retail store at Rawalpindi, which is one of the largest CSD outlets and has a significant customer base. This research describes the retail operations of this outlet only; therefore, the recommendations proposed in this research may not be equally applicable to other outlets of CSD. Consequently, this study can act as a management guide to innovate CSD's operations solely at Rawalpindi.

E. RESEARCH LIMITATIONS

The following limitations exist in the study:

1. Time-constraints did not allow the researchers to study the retail operations of all CSD stores located in Pakistan.
2. Data on CSD's retail operations is limited.
3. Few studies have been conducted on Pakistan's retail industry.
4. Research participants displayed a limited understanding of IoT technological terms and tools.
5. Researching the organization remotely prevented the authors from obtaining first-hand knowledge of CSD's back-end retail operation.
6. Research analysis covering acquisition, financial, and supply chain management aspects of CSD adoption of IoT technologies is based on personal communication with CSD's management since CSD's financial statements were not accessible and their supply chain procedures are undocumented.

F. RESEARCH METHODOLOGY

The study describes the existing technologies and processes in the realm of IoT and in the retail operations of CSD. Subsequently, an in-depth analysis of both aspects is carried out to integrate and describe the processes that CSD can implement to innovate its retail operations to achieve perceived benefits and cost savings. Therefore, the research employs a descriptive approach, and the qualitative analysis relies on the data collected from primary and secondary sources.

The primary source information has been collected through personal communication with subject matter experts (SME) like CSD's management and suppliers. The rationale for discussing CSD's retail operations with SMEs was that the researchers wanted to obtain first-hand information on the retail operations of CSD. The discussions were conducted online via video/voice calls in November 2021, as the researchers were located abroad at the time of study. As regular customers of CSD, the researchers have also given input based on their own retail experiences at CSD stores. In addition, personal communication with CSD's customers, in November 2021, was also carried out in this

study to ensure multiple points of view. The secondary data was collected from research journals, news articles, books, reports, research articles, web pages, blog posts, and conference papers.

G. SIGNIFICANCE OF THE STUDY

A wide range of research has been carried out on matching demand and supply through technological means in retail operations (Bok, 2016). Nevertheless, Bok (2016) noted that besides these two fundamental drivers of the retail supply chain, very little research has been conducted to analyze technological tools that can be implemented on retail functions. Indeed, the retail industry in developed countries has excelled with greater innovations like self or automated checkout counters, sensor-based customer tracking, in-store personalized promotion, and robotics-based warehousing (Ali & Xie, 2021). By contrast, developing countries like Pakistan have yet to adopt the aforementioned innovative retail operations (Ali & Xie, 2021). The main reason for such a lack of innovation is that very little research has been carried out on the retail industry of Pakistan. Therefore, this research has attempted to identify and evaluate possible technology-based solutions that can be implemented in CSD's retail operations. The solutions are focused mainly on increasing demand visibility and availability of the items, decreasing checkout time for the customer, and creating value in terms of smart customer relationship management. The research addresses fundamental processes wherein CSD can embed the recommended technological tools to better serve its customers and gain a competitive advantage over other retailers in Pakistan. Moreover, the research forms a basis for further studies on adopting IoT across the entire CSD chain in Pakistan. The study highlights various technological solutions that will most likely be helpful to other commercial retail stores in Pakistan, depending upon their organizational policies and resources.

H. CHAPTER OUTLINES

The research consists of five chapters. Chapter I, "Introduction," has described the associated importance of IoT in the retail industry. Additionally, this chapter has presented the problem and research questions shaping the research objectives. This chapter has also

explained the scope of the research, its limitations and significance, and the research methodologies adopted to conduct the research.

Chapter II, “Background,” discusses the Pakistani retail industry and its associated significance in CSD’s retail operations. The chapter briefly explains the purpose and mission of CSD. Moreover, the chapter also explains CSD’s retail operation from CSD’s management, customers’, and suppliers’ perspectives.

Chapter III, “Literature Review,” synthesizes the research already done in the domain of adopting IoT in the retail sector. The chapter presents a discussion of various research articles to explain the need to innovate retail operations. In particular, the chapter focuses on research articles related to the utilization of information technology (IT) to improve retail operations. The chapter also contains explanations of the different components used in adopting IoT and the organizational requirements and potential issues arising from the adoption of IoT technology.

Chapter IV, “Findings and Analysis,” presents an in-depth analysis of findings from the secondary research to evaluate the suitability of IoT implementation in the retail sector. Subsequently, a detailed critical analysis is presented of CSD’s processes and where IoT-based solutions can be dovetailed into CSD’s retail operations. The analysis includes the rationale for selecting specific IoT solutions and also highlights the potential benefits and issues the solutions pose for CSD. The researchers also give their analysis on how to mitigate the potential issues and ensure the successful implementation of various IoT applications. The chapter also contains an explanation of the integration of numerous IoT-based solutions at CSD.

Chapter V, “Conclusion and Recommendations,” comprehensively concludes the study’s findings. Finally, the chapter contains recommendations on the way forward for CSD’s management to innovate CSD’s retail operations and a discussion of further avenues for research on this topic.

THIS PAGE INTENTIONALLY LEFT BLANK

II. BACKGROUND

As already noted, CSD operates in the Pakistani retail market and faces competition not only from local grocery stores situated at every corner of residential areas but also big supermarkets and superstores that have strong distribution channels and a huge customer base. CSD's primary customers are armed forces personnel; however, CSD stores also attracts civilian customers who have access to the stores. This chapter explains CSD's business environment in to order develop an understanding of CSD's retail operations for subsequent implementation of IoT.

A. CSD EXTERNAL ENVIRONMENT – OVERVIEW OF PAKISTAN'S RETAIL INDUSTRY

CSD operates in the Pakistani retail sector, which accounts for almost 61.40% of the Fiscal Year (FY) 2020 Gross Domestic Product (GDP), and is the third largest sector in Pakistan (Arshad, 2020). According to a Euromonitor report on the Pakistani retail sector, the industry has had its fastest growth in the past five years ("Pakistan Retail Market," 2021). The firm Planet Retail recently estimated the Pakistani retail market size to be \$150 billion and to have an annual growth rate surpassing 8% (Arshad, 2020). A major reason for this dramatic growth is Pakistan's expanding youth population, which is gradually becoming a part of the workforce of the country and exercising greater buying power ("Pakistan Retail Market," 2021).

1. Categories of the Pakistani Retail Sector

The Pakistani retail sector is divided into two main categories (Tirmizi, 2010). The popular and most extensive category, with a footprint in most rural areas, consists of the traditional retail outlets located at the corner of every street. While in urban areas, these traditional "mom-and-pop" stores compete with the local and international chains of superstores and supermarkets (Tirmizi, 2010). Traditional mom-and-pop stores have indeed dominated the retail industry since the independence of Pakistan; however, increased customer awareness has challenged traditional retail businesses, especially in megacities (Ali, 2020). Retail customers demand not only greater variety of products but

also an enriched experience of shopping and superior services (Irfan et al., 2019). These changing customer preferences have resulted in increased construction of mega shopping malls, supermarkets, and discount stores in urban areas of the country (“Pakistan Retail Market,” 2021). In particular, the high-end customer segment is more inclined towards these mega shopping malls (Irfan et al., 2019).

2. Emerging Trend in Pakistani Retail Sector

Apart from brick-and-mortar retail stores, there has been a trend of increased online shopping especially triggered by the COVID-19 pandemic (Ali, 2020). Although the mega e-commerce store Amazon has not yet offered its services in Pakistan, its major rival Ali Baba has penetrated the market through its acquisition of Daraz, a popular online e-commerce store in Pakistan (“Ali Baba Acquires Daraz,” 2018). Indeed, the country’s retail sector is undergoing dynamic change, and online retailing is posing a major challenge to traditional retailers and supermarkets (Ali, 2020). In order to compete with this trend, the majority of large grocery retailers have introduced online shopping services (Rizvi et al., 2019). Pakistani retail customers, however, are still reluctant to buy groceries online due to quality issues and the relatively high cost of items (Rizvi et al., 2019). This poses yet another challenge to the retail sector as retailers have to maintain and sustain an omnichannel distribution system to remain competitive in the retail market of Pakistan (Rizvi et al., 2019).

A snapshot of grocery outlets depicts that there are few retail chains in the country (Arshad, 2020). The established chains do not operate local discount stores and have limited their retail operations to supermarkets in urban areas (Arshad, 2020). One can also observe that even these large retailers have established only a few supermarkets in the entire country, and especially in the urban areas, these supermarkets are usually located far from residential areas and are not readily accessible to all customers. Consequently, most of these supermarkets have an online presence and are maintaining omnichannel distribution (Rizvi et al., 2019). Rizvi et al. (2019) further elaborate that online presence is just another market offering as grocery retail customers are more inclined towards in-store shopping, and thus, online shopping does not have a huge impact on sales.

Small and medium-sized retailers do not have retail chains throughout the country, so they cannot achieve supply chain efficiencies or economies of scale, and therefore, they cannot offer more discounts to their customers (Irfan et al., 2019). As a result, a trade-off exists for a typical retail customer, especially in the urban areas where the customer either shops at a local store with high accessibility or travels a distance to the supermarkets offering high discounts and a better shopping experience (Arshad, 2020).

3. CSD's Positioning in the Pakistani Retail Sector

CSD has a competitive positioning in the retail market as its stores are located near the armed forces' residential areas and in the military garrisons, as highlighted by CSD's managing director (personal communication, November 7, 2021). CSD has more than 100 retail outlets and supermarkets throughout Pakistan, covering rural and urban areas (CSD The Caring Store, n.d.). In the rural areas, CSD has established small discount stores based on customer foot traffic, whereas in the urban areas, CSD has established supermarkets following the norms of large commercial retail supermarkets. In this regard, CSD is filling the gap between the traditional local store and superstores, being easily accessible to its primary customers and offering a supermarket experience.

B. OVERVIEW OF CSD'S RETAIL OPERATIONS

CSD's retail operations have been investigated from three perspectives to identify and recommend an IoT approach for innovation. These three aspects include CSD's customer experience, internal retail management, and supplier relationships. These aspects are discussed in the following paragraphs.

1. CSD's Customer Experience

As regular customers of CSD, the researchers have personally observed CSD's retail offerings and held discussions with many other regular customers of CSD to analyze the experiences of CSD's customers. During the discussions held between the researchers and other regular customers, it was noted that CSD is lacking in customer relationships. There is no formal channel through which CSD's customers can communicate their needs to the retailer's managers. For example, aisle management at the stores is sometimes

compromised. The products are often placed in the wrong aisles and shelves, which is frustrating for shoppers. The store staff is usually engaged at the point-of-sales (POS) counters, however, and not available to help customers during their retail shopping. When a customer is unable to find a particular product at the shelf and needs directions to the aisle of a specific product, the staff is not available to guide them. There is no mechanism whereby the customer can easily track specific products' aisles at CSD, and customers spend most of their time searching for the products at CSD stores. During the researchers' discussion with customers, it was concluded that overall, CSD's customers are only moderately satisfied with their shopping experience, and that satisfaction is due to the convenience of CSD's location and discount prices. By adopting emerging technologies, CSD could provide an enhanced retail shopping experience for its customers. Making these improvements could convert the shopping experience from a moderately to a highly satisfactory one and develop a strong customer relationship.

2. CSD's Internal Retail Management

The researchers had a detailed discussion with the management of CSD to understand the retail operations of CSD. The management revealed that CSD deals directly with Fast Moving Consumer Goods (FMCG) companies. There is no distributor between FMCG and CSD, except for commodity and produce items. The FMCG products include inexpensive everyday items such as packaged food, toiletries, house cleaning products, etc., whereas commodity items consist of flour, rice, sugar, etc., and produce items include fruits and vegetables. Moreover, CSD has its own unique distribution channel to support its more than 100 outlets in Pakistan.

As discussed with CSD's managing director (personal communication, November 7, 2021), CSD has divided its stores into seven clusters based upon their locations within Pakistan. CSD has termed those clusters as zones and assigned a single distributor to each zone. These distribution centers (DC) are assigned the responsibility of receiving goods from the manufacturers and then distributing goods to CSD stores as per the demand. The majority of CSD stores do not have big warehouses to keep inventories, and instead, the entire inventory is placed on the shelves and aisles of the individual stores. As managing

director highlighted, only large stores like the Rawalpindi CSD store have a warehouse in which to keep sufficient inventories of items having a high consumption rate.

Clearly, CSD's material and information flow was critical for this research, and therefore, the researchers engaged in a detailed discussion about this topic with the management of CSD. The company's managing director (personal communication, November 7, 2021) noted that CSD has its enterprise resource planning (ERP) set up to manage and control the flow of information. The information flow is mainly based upon demand information taken from the sales data generated at the POS. The sales data is then transferred to the DCs and subsequently to the procurement department at CSD's headquarters through its ERP. The procurement department accumulates demand from all DCs daily and then initiates the purchase order (PO) in the ERP. The sales data from each CSD store serves as an input to forecast the future demand. It was observed that CSD does not use any specific forecasting techniques to predict future demand. Therefore, it is assumed that the forecast for the future demands of items is mainly based on the judgment and speculation of CSD's procurement manager with input from past sales data. The speculation-based forecast is then communicated to the relevant manufacturers/vendors as a PO via an online vendor portal system. The PO specifically communicates the description and the quantities required at each CSD's DC.

CSD's management highlighted that as soon as the PO is received at the respective manufacturer, the order is processed for fulfillment. Since many manufacturers have different facilities all over Pakistan, the facility located nearest to a CSD's DC is responsible for the shipment of orders. CSD's management estimated that the lead time of each PO is usually a week for most manufacturers. When the items are received at the DCs of CSD, they are further segregated for each CSD located within the zonal DC and then transported through a trucking fleet maintained by CSD itself. After items are received at CSD's stores, they are placed onto shelves and aisles; excess quantities are usually placed at the back-end warehouse if available, but otherwise, they are placed in open storage areas in the stores.

3. CSD's Supplier Relationship

The majority of CSD's suppliers are manufacturers, producers, or large distributors, as highlighted by CSD's managing director (personal communication, November 9, 2021). These suppliers have a wide range of customers, and the resources of each supplier also vary. Therefore, CSD's management cannot use a single approach to control material and information flows with each supplier. While most suppliers prefer to communicate via email and phone, some suppliers prefer to visit the actual location of stores to measure the inventory levels of their respective items and speak with the store manager regarding the replenishment of items at each CSD store. Therefore, CSD has established an entire procurement department at its headquarters, which is further divided according to the type of products and items.

The researchers' discussion with CSD's suppliers (I. Khan, A. Javed, and S. Mazari, personal communication, November 9, 2021) revealed that CSD has established a strong and reliable relationship with its suppliers. This relationship with suppliers has supported CSD in the timely replenishment of items during surges in demand, except for a few instances. The replenishment lead time of items is also reliable, with very low deviation and uncertainties. CSD's management stated that the rationale for such a supportive relationship with the suppliers is CSD's sound financial practices. CSD has the policy to clear the outstanding invoices of suppliers within the defined time instead of delaying payments. According to one of the suppliers (I. Khan, personal communication, November 9, 2021), the timely payment of outstanding invoices from other retailers is rarely observed in the Pakistani retail market. The supplier further highlighted that most large retailers with a chain of stores are usually slow to pay within the defined time of contract. Since bulk quantities are usually pushed to these large retailers, the suppliers cannot usually invoke legal remedies for payments to keep their products at the aisles of giant retailers.

C. IOT-BASED RETAIL MARKET OPPORTUNITIES FOR CSD

In today's era, digital customer information is considered as valuable as gold, and without such information, it is difficult for the companies relying on customer information

to make informed decisions (Shakhidi, 2020). Before the advent of the Internet, the collection of information was an arduous and time-consuming task (Verhulst & Young, 2018). Technological advancements have shaped new realities through a variety of advanced devices like Amazon Alexa, smartphones, smartwatches, etc., that have helped to make life easier, and in parallel, these devices have become information collection points (Allmendinger et al., 2017). In particular, these technological devices have provided the commercial sector with the effortless collection of information (Dörndorfer & Seel, 2016). For instance, consumers following a specific exercise and diet routine to lose weight do not necessarily have to inform the nearby grocery retail outlet that they need specific food items to maintain their diet. Instead, their smartwatch and smartphone are already collecting information on each consumer's routine and informing the nearby grocery outlets and online e-commerce stores through the giant web of the IoT ecosystem. Since the companies can easily obtain information on a specific consumer's needs and wants (Lo & Campos, 2018), companies can tailor their marketing and advertising strategies to make sure that their products are bought by that person or persons with similar characteristics (Verhulst & Young, 2018). Similarly, this huge information network managed by IoT can benefit retail businesses in understanding customers' needs and subsequently enable them to tailor their offerings in the market with much more informed decisions as compared to the previous era in which retailers tried to drive demand by bombarding the public with general advertisements (Caro & Sadr, 2019).

IoT has also developed technological solutions that have reduced the need for human interaction while improving service in the retail stores (Dlamini & Johnston, 2016). As the increased utilization of technologies in the past few decades fueled the need to innovate and improve the operations of almost every industrial sector, the same trend has also emerged in the retail sector (Pantano et al., 2018). The evolving technological solutions in the retail sector are highly influenced by an IoT-based approach. Moreover, IoT-based retail operations are not limited to the conventional utilization of computing devices for information gathering. The IoT-based approach entails the utilization of a network of devices and continuous collection of information without vesting human efforts (Liu et al., 2018).

The researchers' conversation with CSD's managing director (personal communication, November 8, 2021), however, revealed that CSD does not yet incorporate IoT-based infrastructure to improve its retail operations. Specifically, CSD does not have an IoT-based information gathering system to make informed decisions about its customers' needs. Instead, CSD follows the traditional convenience store approach of collecting demand data from POS only. Meanwhile, it should be noted that online sales comprise only 5% of CSD's overall sales, and therefore, information collected from online customers is not sufficient for formulating retail strategies at this time. It is apparent that CSD is missing an opportunity to utilize an IoT-based approach to better serve its customers and improve its retail operations. Great potential benefits exist in adopting an IoT-based approach to operating CSD's retail activities. Nevertheless, not all IoT-based approaches are suitable for adoption in terms of their acquisition costs and viability within the Pakistani retail environment. Therefore, there is a need to study and analyze IoT applications that can feasibly be implemented at CSD.

III. LITERATURE REVIEW

The utilization of technology is increasing rapidly in the commercial sector. One can observe that a combination of various technologies within IoT plays a significant role in improving retail processes. At the same time, the adoption of IoT has also raised certain challenges, and suitable strategies are needed to address those challenges before the implementation of IoT-related technologies. In order to lay the foundation for an analysis of IoT's implementation at the CSD store in Rawalpindi, this chapter explores the concept of IoT, IoT's application in a retail setup, and its associated perceived benefits and challenges.

A. DEFINITION OF IOT AND APPLICATIONS FOR IOT

No single definition of IoT is widely accepted (Rose et al., 2015). Many researchers have defined IoT as a network of devices connected via the Internet to gather and process the data and subsequently share the information to make informed decisions (Sharma et al., 2019). According to "Here's how the Internet of Things will explode" (Business Insider, 2016), IoT solutions have attracted large investments reaching \$6 trillion. Most of the investments in IoT are being made by businesses and governments (Bennett, 2017). It is imperative to highlight that businesses with less focus on adopting IoT solutions will have fewer competitive advantages compared to businesses making huge investments in IoT solutions (Das, 2019). It seems less likely that in the future, businesses would not have some embedded IoT solutions (Sharma et al., 2019).

In the absence of IoT solutions in the past, organizations usually relied on available information without having any comparative advantage over their competitors in terms of better information (Das, 2019). IoT solutions have enabled organizations to utilize unique artificial intelligence (AI) and machine learning expertise to collect and process information efficiently and effectively compared to competitors who lack such solutions (Shafique et al., 2018). Rapid and effective information gathering and processing has enabled businesses to gain a unique competitive advantage in addition to what they enjoy from their usual business offerings (Ali & Xie, 2021).

IoT has created automation in many areas as the interconnectivity of various devices followed by real-time information sharing provides instructions to numerous other devices without human interaction or intervention (Kramp et al., 2013). Some examples of IoT observed in the following industries highlight its working methodology and extent of automation:

1. Hospitality Industry

IoT has enabled hotels to install motion sensor devices in the room refrigerators filled with different snacks and drinks (Malliaris, 2018). Malliaris (2018) elaborated that as soon as the guest takes any items from the room refrigerator, the guest is billed for items without any human intervention. Moreover, IoT infrastructure can also predict the consumption trend of items in each category of rooms to suggest what items the procurement managers of hotels should order, without expending much effort in knowing customer demand (Nadkarni et al., 2019). IoT has also enabled hotels to reduce the operational cost associated with energy consumption (de Carvalho Silva et al., 2017). In terms of automation and improved customer experience, the IoT has enabled hotel guests to book and reserve rooms online with self-check-in, check-out systems, and smart rooms managed through mobile applications (Mercan et al., 2020). Similarly, a wide range of operations in the hospitality industry can be observed employing IoT infrastructure (Car et al., 2019).

2. Health Care

IoT has played a pivotal role in monitoring personal health through its infrastructure of wearable devices and smartphones (Malliaris, 2018). These devices track data on heart rate, blood pressure, and daily exercise to predict certain nutritional deficiencies and suggest diet plans to follow (BinDhim et al., 2015). The apps embedded in these devices also monitor the weather and warn users of any illness or allergies that might arise from certain weather conditions and suggest precautions based on a person's health conditions (Malliaris, 2018). All such data being continuously monitored is seamlessly shared with health care providers and doctors, which enables them to continuously monitor their patients without making regular office visits (Heidel & Hagist, 2020). Accordingly,

numerous other IoT devices are being utilized in the medical sciences, which have enabled better services for patients with a chronic medical condition (Mendiola et al., 2015).

3. Education

Highly interactive education games powered by IoT devices have enabled educational institutions to engage their students in a fun-loving manner (Ling et al., 2022). Ling et al. (2022) further highlighted that the educational games automatically adapt to each student's learning capability and subsequently interact with the students according to their capacities. IoT has made education an interactive experience rather than the traditional one-way consumption of information (Malliaris, 2018). Moreover, IoT has aided in the development of technologies that can automatically adjust the font size on the computer screen for visually impaired students (Malliaris, 2018). Educational technologies like smart whiteboards and video recording of lectures have provided great help to the students to access their classroom information at any time (Alelaiwi et al., 2015). Similarly, several IoT-enabled technologies can be found throughout the education sector playing a pivotal role in improving the education system (Mohammadian, 2019).

4. Freight and Logistics

IoT has revolutionized the entire freight and logistics industry (Tran-Dang et al., 2020). In one example, IoT infrastructure installed at various manufacturing sites, DCs, warehouses, trucks, containers, ships, and other facilities, has provided real-time tracking of parcels (Chen et al., 2021). The sensors installed at the exit/entry points at various echelons of the supply chain can count an entire lot of thousands of items within seconds, freeing the facility employees from physical counting of items (Derakhshan et al., 2007). Similarly, an item can be tracked without human intervention from the point of its manufacture to the point of its sale (Mishra & Mohapatro, 2020). The increased visibility of items in the supply chain has created an advantage for the retail industry (Shamsuzzoha et al., 2021).

5. Application of IoT in Daily Life

A wide range of IoT applications can be observed in an individual's daily routines (Kramp et al., 2013). In smart homes, the monitoring utilities of various kinds of sensors can accurately give the consumption pattern of a household and predict future consumption (Longe et al., 2015). A device like Google Nest can sense the temperature in a house and automatically adjust the temperature to the desired level (Noto La Diega & Walden, 2016). These devices can also shut off the heater/air conditioner automatically when there is no one in the house (Noto La Diega & Walden, 2016). Similarly, devices like Amazon Alexa can perform a variety of functions on their own by learning the specific behaviors of each household (McLean & Osei-Frimpong, 2019). Fire safety sensors can detect fire hazards and automatically shut off all the appliances and notify the local authorities to initiate actions (Perilla et al., 2018). Almost all appliances like refrigerators, washing machines, TVs, air conditioners, heaters, and others, can be controlled through smartphones (Wang et al., 2015). Through a smartphone, a homeowner can set the temperature of his or her house without being in the vicinity of the house (Nur-A-Alam et al., 2021). Smart cars make it possible for an owner to turn off appliances after leaving the house and turn on the desired appliances as soon as the car comes within a specific distance of the house (Malliaris, 2018). Similarly, a smart car has a variety of sensors that help drivers know of hazards in advance to prevent an accident (Krishnan, 2018). Furthermore, devices in cars are continuously transmitting data to other parties like insurance companies, police, and highway/road authorities so those parties can make well-informed decisions and responses when a situation arises (Malliaris, 2018).

B. NEED TO INNOVATE RETAIL OPERATIONS

Today, the innovation of retail operations is driven by the fact that retail stores are facing stiff competition from their rivals and the emerging challenges of transforming business into an e-commerce domain (Vel et al., 2010). Moreover, the new entrants in the market generally follow the existing positioning strategy of retailers without offering their unique selling proposition (USP) (Ali & Xie, 2021). The established retail differentiation strategies followed by retailers are also not aligned with the changing needs of customers

(Dennis, 2020). Instead, such strategies are heavily inclined toward product quality and supply chain relationships (Caro & Sadr, 2019). As a result, the strategies have traditionally enabled retailers to offer their products at lower or at par prices with their competitors (Caro & Sadr, 2019). However, the focus of retail strategy has now shifted toward a customer-centric approach (Huo, 2021). The time a customer spends at a retail store and his or her associated experience is a source of great insight for retailers to draw on in deriving their strategies (Hermes & Riedl, 2021). Hermes and Riedl (2021) highlight that the customer experience does not necessarily depend upon the number of purchases made. Instead, it is dependent upon numerous other factors that cannot be captured through sales data. In order to observe customer experience and make relevant strategy, retailers need to innovate their existing practices (Ali & Xie, 2021). Conversely, retail businesses that fail to innovate with changing customer needs will face numerous challenges and may perish in the long run (Grewal et al., 2018).

1. Domains of Retail Innovation

Innovation in the retail business can be carried out in two domains: retail identity and retail physicality (Vel et al., 2010).

a. Retail Identity

A retail identity is primarily established through a brand name (Siqueira et al., 2021). The brand name reflects many aspects of a retail business (Ailawadi & Keller, 2004). A brand is an image that a consumer holds about a retailer's pricing strategy, quality, after-sales services, etc. (Vel et al., 2010). A retailer with a strong brand name communicates with its customers about the consistent quality of services (Ailawadi & Keller, 2004). Consequently, a retailer with unique and strong brand representation can maintain a significant market share that ultimately yields higher revenues (Burt, 2000). A strong brand name depends not only upon the quality of items offered by the retailer, but also whether the retailer offers a commitment to high quality service in the form of CRM (Zamil, 2011). If a consumer has concerns about the retailer's quality of service, they know that their voice is given attention and importance (Zamil, 2011). Therefore, a retailer needs to have an infrastructure that ensures that the customer relationship is given its due

importance (Vel et al., 2010). That is why departments devoted to CRM are now common at various companies (Zamil, 2011). Accordingly, managing CRM by adopting innovative technologies provides cost-effective solutions (Garrido-Moreno et al., 2015).

b. Retail Physicality

According to Vel et al. (2010), the physicality of retail business goes beyond the concept of a traditional brick-and-mortar building. The authors further elaborated that physicality encompasses all the external and internal appearance of a store, including displays of merchandise, in-store promotions, store ambience, and the unique internal atmosphere at a store. These aspects create a great customer experience and can serve as a differentiation strategy for the retailer that makes it unique from its competitors (Vel et al., 2010). The in-store customer experience sometimes creates more value than the actual value of the products offered by the retailer (Hermes & Riedl, 2021). Therefore, innovative ways to improve the in-store customer experience at retail stores play an important role in creating a competitive advantage for the retailer (Grewal et al., 2020).

2. Innovative Technologies Driving Retail Transformation

Retail transformation is driven by innovation in new and evolving technologies (Progressive Grocer, n.d.). These new and evolving technologies have provided high levels of connectivity between businesses and have provided details in tracking and locating merchandise in ways that seemed impossible in the past (Progressive Grocer, n.d.). These new technologies have also allowed flexibility in doing retail supply chain operations (Chen et al., 2021) and provided numerous opportunities in transforming businesses from physical stores to e-commerce (online) stores (Mohdhar & Shaalan, 2021). The emerging technologies have indeed provided ease for businesses in many domains; however, they have also introduced many challenges for businesses in meeting customer demands by requiring retailers to maintain both traditional and omnichannel distribution strategies (Ishfaq et al., 2016). In this regard, the most powerful and innovative technologies that have shaped a new era of retail operations are as follows (Progressive Grocer, n.d.):

a. Cloud Computing

Cloud computing has played a major role in transforming retail operations (Maqsood & Haseebuddin, 2015). In 2017, a global retail cloud computing market evaluation reached about \$13.24 billion (Progressive Grocer, n.d.). This market evaluation is estimated to rise to approximately \$40.75 billion by 2023 (Progressive Grocer, n.d.). The fundamental reason for such a huge increase in the utilization of cloud computing by the retail sector is reduced operating expenses (Progressive Grocer, n.d.). Cloud computing has allowed retailers to outsource their information collection and processing setup as it involves a network of servers hosted by third-party IT companies and connected through the Internet (Maqsood & Haseebuddin, 2015). Previously, a retail business was heavily dependent upon its ERP for information collection, and processing of demand and payment information consumed significant resources in storing, managing, and processing data on its local servers (Progressive Grocer, n.d.). The huge costs associated with the maintenance of these servers often prevented small businesses from adopting sophisticated ERP solutions (Hustad & Olsen, 2013).

b. Big Data

The availability of advanced data processing software applications has enabled retail businesses to extract valuable insights from large and complex data sets (Progressive Grocer, n.d.). Previously, the processing of large data sets had been a complex and time-consuming task for traditional software applications (Nasser & Soomro, 2015). The advancement of technologies has resulted in the development of sophisticated software applications that not only process the data at a fast pace but also provide real-time insights from millions of data points (Altarturi et al., 2017). These advanced software packages can utilize different mathematical models to generate patterns, market trends, and correlations and identify customer preferences (Altarturi et al., 2017). These real-time data insights have helped retail businesses make well-informed decisions and implement relevant strategies to meet customer preferences and needs (Bok, 2016).

c. Radio Frequency Identification

Radio frequency identification (RFID) has transformed the supply chain of retail businesses (Mishra & Mohapatro, 2020). RFID utilizes chips, readers, scanners, and small chips equipped with antennas to locate and identify tagged items (Derakhshan et al., 2007). The RFID infrastructure involves the scanning of tags pasted on each item through hand-held or fixed readers (Derakhshan et al., 2007). A user standing in front of an aisle or rack can obtain information on inventory levels, expiration date, location of an item, and any other criteria without physically seeing the item placed in a rack/aisle (Kasiri, 2021). The growth of RFID has been substantial and rising at a 14.1% compound annual growth rate (CAGR) since 2017 (Progressive Grocer, n.d.).

d. Artificial Intelligence

The devices and systems incorporating AI mechanisms can utilize complex algorithms and make decisions through countless data points (Cao, 2021). AI can learn from the data and make predictive decisions (Guha et al., 2021). AI systems can learn from data obtained from human behaviors while consumers are purchasing items and subsequently can imitate customer behavior (Liu et al., 2018). The implementation of AI in retail operations has enabled retailers to predict the customers' next course of action based on their buying patterns and existing market trends (Progressive Grocer, n.d.). Prior to the implementation of AI, during supply chain planning, a retailer could only utilize historical data to forecast future demand, which did not take into account current market trends, seasonality, inflation, and economic conditions (Progressive Grocer, n.d.). On the other hand, AI has enabled the retailer to consider all of these factors while obtaining real-time data from different sources and then processing it through complex algorithms to forecast future demand as accurately as possible (Progressive Grocer, n.d.). An AI mechanism also takes into consideration internal factors including current inventory level, inventory in transportation, inventory currently held at various echelons of the supply chain, and so on (Liu et al., 2018). The consideration of internal and external factors while making forecasts results in the ability to match the demand without having to hold

enormous stocks and compromising the level of service experienced by the customer (Progressive Grocer, n.d.).

e. IoT

IoT can be considered as the blend of new and evolving technologies discussed previously (Progressive Grocer, n.d.). IoT consists of a network of devices, including RFID scanners connected through cloud computing via the Internet (Mishra & Mohapatro, 2020). The input from a network of devices is a huge amount of data, which is then synthesized by sophisticated software applications backed by AI-based mechanisms to suggest real-time insights that enable the retailer to make well-informed decisions in the retail arena (Guha et al., 2021). Therefore, IoT has the potential to transform retail practices and provide enhanced customer experiences (Bok, 2016).

C. IOT-BASED RETAIL OPERATIONS AND THEIR ADVANTAGES

The need to innovate retail operations is driven by the cutthroat competition in the retail industry (Pantano et al., 2018). Yet, as discussed earlier, strong demand to innovate retail operations is ultimately driven by consumers (Huo, 2021). Consumers today are less influenced by the message projected in marketing and advertisement campaigns; they are more likely to carry out their own detailed research while shifting to or adopting new brands of products or services (Hermes & Riedl, 2021). They are well-informed about their needs and wants and particularly know the alternatives for each option (Hermes & Riedl, 2021). They have adequate knowledge about products and the pricing strategy of retail businesses (Ali & Xie, 2021). With such well-informed customers in the market, it is necessary to formulate a retail strategy based on customers' preferences and choices (Bok, 2016).

A survey on customer experience highlighted that 86% of customers would pay an additional price to the retailer in favor of a better shopping experience (Reddy, 2015, as cited in Bok, 2016). In this regard, IoT can help to inform such strategies by conveying real-time data insights about individual customers that can help a retailer formulate a customized strategy for each type of consumer (Bok, 2016). Accordingly, the following

are the ways by which IoT promises innovative retail experiences for customers, which can in turn yield higher revenues for retailers.

1. IoT-Based Store Layout

An IoT-based store layout offers the possibility of installing sensors to detect customers moving from one aisle to another to optimize the layout for more in-store purchases (Bok, 2016). The sensors and cameras can also track customer behaviors and reactions while looking at different products placed in the aisles (Sturari et al., 2016). Those behaviors and facial reactions of customers can help to determine the customer's preference for products (Sturari et al., 2016). Accordingly, the store layout can then be developed to give the customer easier access to the items with the most customer demand and purchases (Bok, 2016).

Hugo Boss utilizes heat sensors to track the movement of customers in its stores and subsequently places premium products in the aisles with the most customer foot traffic, which has increased sales of the company's premium-priced products (Gregory, 2015). Layout optimization is expected to contribute to a potential benefit of \$158 billion and a 5% increase in productivity by 2025 (Manyika et al., 2015). Similarly, another research conducted by Parada et al. (2015) utilized RFID to detect user-object interaction and proposed measurement tools to support customer purchase decisions and ensure timely availability of products. The measurement tool helped increase sales performance of the products by 80% (Parada et al., 2015).

2. IoT-Based Automated Checkout

IoT provides retailers the opportunity to offer negligible checkout time (Sarwar et al., 2020). It is imperative for retailers to understand that the time consumed at the retail checkout is a major concern, especially during peak periods and holidays (Rehman & Charpe, 2021). Checkout experiences involving long wait times and lines is one of the most intensive processes and acts as a source of frustration for the customers (Wankhede et al., 2018). This factor alone can have a significant adverse impact on the customer shopping experience (Sarwar et al., 2020). Retailers with the shortest checkout time at their stores

provide more value to customers than retailers with longer checkout times (Rehman & Charpe, 2021).

In view of the high importance of checkout time, it can be observed that superstores usually establish multiple counters for checkout and deploy staff at these counters as needed (Rehman & Charpe, 2021). Yet, even though a superstore might have multiple checkout counters, all these counters may not be operating at all times as it would not be cost effective to operate all of them simultaneously when there are few customers in the store and customer wait time is almost negligible (Rehman & Charpe, 2021). The rationale for not operating all checkout counters simultaneously is that it would be costly, and that increase cost would ultimately be transferred to the customers (Sharma et al., 2021). Therefore, while retailers need to ensure the optimal number of checkout counters, they should operate all of them simultaneously only when long lines begin to form at the checkout counters and the customer's wait time continuously increases, particularly during holidays (Sharma et al., 2021). In order to reduce wait time at checkout, some retailers have also introduced express checkout counters to accommodate customers with fewer than a certain number of items in their cart; (Coronado-Hernández et al., 2021), self-checkout counters (i.e., customers can themselves process the payment of items; Sharma et al., 2021), and automated checkout systems to help their customers in early payment processing and enhance their shopping experience (Wankhede et al., 2018). However, self-checkout and express checkout counters are not necessarily the most feasible solution as customers may still have to wait in lines at these counters, although for a shorter duration because of fewer customers and quicker processing time at these checkout counters (Coronado-Hernández et al., 2021; Sharma et al., 2021; & Wankhede et al., 2018).

The most feasible solution to decreasing customer wait time at checkout lines is the IoT-based automated checkout system wherein customers do not have to wait in line at all (Wankhede et al., 2018). The customer can scan a mobile app upon entering the store and keep on adding items to their cart (Wankhede et al., 2018). Wankhede et al. (2018) add that as soon as the customer is done shopping, he or she can cross the scanner at the exit of the store, which can read all the RFID tags on the items in the shopping cart and their associated prices/quantities and transfer the information to the wireless payment processing system

linked with the customer's app. Subsequently, customers can leave the store without any wait time for payment processing at the store (Wankhede et al., 2018). Not only can retailers provide value to customers through IoT-based checkout systems, they can also reduce their labor costs as there will be no need for cashier staff at the counters (Sarwar et al., 2020). It is estimated that IoT-based automated checkout procedures can reduce staff by 75%, which could result in significant cost reductions (Manyika et al., 2015).

Indeed, an IoT-based automated checkout system is ideally suited to reduce cost and enhance the customer shopping experience; however, very few retailers have adopted this technology due to a lack of awareness (Bok, 2016). Presently, Amazon Go is the only physical retail store employing this model in the retail market (Wankhede et al., 2018). Meanwhile, Disney is using a similar method by issuing MagicBands to its customers; the wristband serves as an RFID tag and allows customers to check in to their hotel rooms, buy food and merchandise, and so on (Borkowski et al., 2016). The said RFID tag also keeps a record of customers' movements, preferences, and purchases, which ultimately enables the Disney's management to make informed decisions about advertisement strategies and inventory stocking policies (Borkowski et al., 2016).

3. IoT-Based Store Map

An IoT-based store mobile app that has the complete map of a store along with details about each item placed in an aisle can add value to the shopping experience (Bok, 2016). It is very frustrating for the retail customer to locate a specific item when there is no assistance in the store (Hicks et al., 2013). When an item cannot be easily located by the customer, this factor may not only results in loss of sales but also contribute to a negative shopping experience (Bok, 2016). Moreover, customers might not return to the store if most products are not easily found (Hicks et al., 2013). In order to address this issue, superstore retailers normally hire an adequate number of staff to assist customers with locating products (Tlapanana & Mduba, 2021). However, IoT can provide a cost-effective technological solution that reduces the customer's frustration in trying to locate specific products (Hicks et al., 2013). IoT can also help to reduce the labor costs as fewer store staff would be needed to help the customers locate specific products (Bok, 2016).

This type of IoT-based solution consists of a mobile app known as SmartMart (Hicks et al., 2013). The app provides the complete floor plan of the retail store with the real-time location of each item in every aisle (Hicks et al., 2013). The app can allow the customer to enter a specific item name in its search bar and get the item's location through an indoor positioning system (IPS) and an RFID tag on the item (Hicks et al., 2013). The app can not only provide the customer with the real-time location of an item in the store, and it can also help managers locate a misplaced item in the store (Hicks et al., 2013). Hicks et al. (2013) explained that if the customer uploads a complete grocery list in the app and enters the location of a particular store, the app can suggest the shortest pathway to pick up all the items on the list in that store. This way, customers can significantly save time in the store, and the retailers can improve the shopping experience by facilitating the customers with such technological solutions (Hicks et al., 2013).

4. IoT-Based Shelf Availability

In the retail marketplace, one of the most important aspects of good customer experience is the on-shelf availability (OSA) of the item, which can be addressed through IoT in a seamless manner (Mishra & Keshri, 2021). If the customer arrives at a store to buy a certain product and that product is not available on the expected aisle, this results in the worst customer experience and loss of sales (Kalange et al., 2017). The same customer can buy the missing product from a competitor, and the retailer can expect to lose the customer in the long run if the stock-out situation is frequent at the store (Khanna & Tomar, 2016). There is a potential loss of 4% in annual sales due to out-of-stock products (Bok, 2016). In order to ensure OSA, retailers have adopted numerous strategies and sophisticated forecasting models to meet customer demand (Mishra & Keshri, 2021). The main explanation for an out-of-stock situation is that the retailer was unable to forecast the actual demand for an item (Khanna & Tomar, 2016). Moreover, even when the item is available in the back-end warehouse, but because of the challenge of managing a huge inventory, managers may be unable to replenish the stock promptly in the store aisle (Bok, 2016). Therefore, OSA is an important metric for customer experience, and it is a strategic retail activity that no retailer can compromise (Vargheese & Dahir, 2014).

A retailer can use two approaches to ensure OSA (Bok, 2016). The first method includes manually auditing the items placed on the shelves after regular intervals, and the second method is to keep track of items leaving POS (Bok, 2016). The latter approach is normally used by big retailers as it is very difficult to maintain manual audits of huge inventories in a store, as the inventory of items can be significantly depleted between the audit intervals and might result in a stock-out situation before the inventory review period (Fiorito et al., 2010). On the other hand, Bok (2016) highlighted that keeping track of POS data is not a sound approach to maintain OSA as it does not provide a holistic summary of inventory levels.

There is an IoT-based automated OSA model proposed by Vargheese & Dahi, (2014), consisting of five stages, each of which has its own algorithm. These five stages combine different elements of IoT installed at the shelf to make informed decisions for the retail managers about the recent stock position at the shelf and in the warehouse (Vargheese & Dahir, 2014). It gives information on misplaced and stolen items as well (Vargheese & Dahir, 2014). This model also provides advice on re-order points to maintain OSA by sending alerts to the manager so that the managers do not have to go through the arduous task of physically counting items or POS data (Vargheese & Dahir, 2014). It also helps to select the appropriate forecasting technique to meet the actual demand (Vargheese & Dahir, 2014). Accordingly, the use of IoT elements in maintaining OSA can result in adequate inventories with no stock-out situations and can contribute to an enhanced customer experience (Kalange et al., 2017).

5. IoT-Based In-Store Promotions

IoT can help to facilitate in-store promotions through mobile apps like iBeacon (Dentamaro et al., 2021). These apps allow the store to send tailored promotional offers to customers in the vicinity (Bernritter et al., 2021). A customer's main identity is his or her mobile phone in the store; when they use their mobile phone, the app gets the data on previous purchases made by the customer through different online shopping apps (Dentamaro et al., 2021). Based on this input parameter involving beacon technology and IoT elements, a customer receives a notification from the store with a certain discount on

products of customer interest (Sturari et al., 2016). The promotion could be exclusive to the customer by sending a unique coupon to the customer's phone, or it could be just an announcement of a promotional offer to everyone (Bernritter et al., 2021). The highly personalized in-store promotion can lead to greater sales (Dentamaro et al., 2021). As per a survey conducted by Infosys, 78% of customers will most likely purchase again from the same retailer if the promotional offers perform the retailer match their interests (Reddy, 2015, as cited in Bok, 2016). In a 2015 study, Manyika et al. estimated that real-time promotion based on personalized interest can result in huge economic benefits, and the productivity of the retail operations can increase by 5%.

6. IoT-Based CRM

A technology-based approach to managing CRM can provide the best solutions to retailers (Ploder et al., 2021). One of the most fundamental aspects of CRM is that the customer wants to feel valued, and the retailers that are good at making their customers feel more valuable tend to have a greater market share than retailers giving no significant importance to CRM (Zamil, 2011). Therefore, most retailers want to make sure that customer priorities are addressed with utmost care (Ailawadi & Keller, 2004). Customers feel more important when they feel that their voice is being heard and when they want advice or an answer to a question, they can receive assistance (Zamil, 2011). Therefore, retailers usually deploy sales staff at various locations in a store to assist customers with any complaint or question (Madhani, 2021). Yet, this kind of staff deployment would be a costly option for superstores that have numerous sections and a high number of customers shopping simultaneously (Madhani, 2021). Consequently, many customers' issues go unresolved due to the non-availability of store staff in a nearby aisle, and such issues may result in the loss of customers and worsen the overall shopping experience (Chen, 2021).

IoT can provide valuable assistance in effectively managing CRM through sensors and cameras (Bok, 2016). Bok (2016) further elaborated that in an IoT setup, a retailer can install sensors and cameras at various locations of within its stores. These sensors and cameras using AI can sense the customer's movements and observe the facial expression of customers. The back-end AI-based technology connected through IoT sensors and

cameras can scan numerous faces at the same time unlike human eyes, which can monitor only one person at a time (Bok, 2016). As soon as AI signals that a customer's facial expression indicates he is becoming perplexed and his movement is also erratic from aisle to aisle, possibly because he is searching for a particular product, the nearest store staff member is alerted to greet the customer and offer help (Bok, 2016). If the customer needs help, he or she could ask the staff member, and in the case that the customer does not need help, then it would be clear that the change in customer behavior is not related to the in-store experience (Bok, 2016).

Similarly, IoT can also help in CRM by analyzing past customer purchases and sending personalized promotions to the customer via email and text messaging (Ploder et al., 2021). Ploder et al. (2021) further highlighted that IoT-collected data from numerous sources can also help to predict common customer issues to management, which could be addressed promptly by the retail managers.

7. IoT-Based Digital Shelf Tags

IoT-based electronic price tags can play a significant role in reducing time spent on placing price tags on items and at shelves (Miguez et al., 2019). The traditional method of pasting price tags is not only time-consuming but also resource intensive. When a superstore offers promotional discounts, significant resources are further expended in replacing paper tags on items and shelves. Moreover, it is frustrating for the customers and impacts the customer experience when the price tags are either missing or incorrect on items. The practice raises questions about the reliability of a retailer, and customers might not trust the retailer's promotions in the future. On the other hand, the situation can be resolved easily with the use of IoT-based digital shelf tags. These tags involve the initial cost of acquisition but offer recurring cost savings.

The digital tags are pasted/hung/placed on the shelf of a particular item (Miguez et al., 2019). These are hardware-based devices with a digital screen giving the price or discount (if any) of the item (SoluM Europe, n.d.). The tags can get their feed from the system's inserted prices of items (SoluM Europe, n.d.). If there is a change in price or the retailers want to offer promotional discounts, then a simple change in system price would

make this update instead of an employee replacing paper tags on shelves or items (Pricer, n.d.). Thus, IoT-based digital shelves can save a lot of time and resources for a retailer in terms of price change (SoluM Europe, n.d.). Moreover, customers are also satisfied when they can easily know the prices of the items from the digital tags without calling for help from customer service (Miguez et al., 2019).

8. Utilization of Augmented Reality

The utilization of augmented reality (AR) at retail stores is another contemporary concept in the retail sector (Nikhashemi et al., 2021). The network of IoT devices attached to virtual reality platforms can aid retailers in knowing customer preferences, especially in the fashion industry (Jayamini et al., 2021). There are AR-based mirrors in apparel stores that allow customers to change the color, size, and other features of apparel simply by tapping on the virtual mirror (Insignares, 2021). The back-end store managers keep a record of all the data related to customer preferences, and they also make suggestions to new customers on the virtual mirror if previous customers have bought certain items in a particular combination (Lawrence, 2016). This data gives an insight into the fashion trends that are liked or disliked by customers, and similarly, this information is transmitted upstream in the supply chain to adjust the production plan (Lawrence, 2016). Although AR is not yet in use at grocery outlets to a great extent (Retail Space Solutions, 2020), this technology has opened new possibilities in terms of product visualization that can better shape the promotion efforts of a grocery retailer (Shinde et al., 2020).

9. IoT-Based Multimodal Distribution and Retailing

IoT-based applications provide effective and efficient logistics support (Song et al., 2021). Therefore, there is an emerging need to adopt a smart distribution system in the retail sector to remain competitive in the market (Ali & Xie, 2021). Increased online sales have challenged traditional brick-and-mortar retailing (Ishfaq et al., 2016). Retailers are increasingly positioning themselves in an online environment by offering their services through either giant e-commerce stores or their online mobile applications (Ali & Xie, 2021). In order to meet the demand at both ends (i.e., brick-and-mortar stores and online customers) retailers face the challenge of maintaining omnichannel distribution (Ishfaq et

al., 2016). In this regard, IoT-based applications can help retailers to maintain such distribution networks with increased visibility and automation (Yaqiong et al., 2018). IoT-based applications enable retailers to gauge the real-time demand at physical and online stores, track the status of inventory at different levels of the supply network, and devise solutions to meet the demand for each type of customer (de Vass et al., 2021). Such solutions include accuracy of forecasted demand, personalized promotion to customers, and a highly integrated inventory management system, which results in maintaining lower inventories while meeting the desired customer service level (de Vass et al., 2021). Moreover, the utilization of robotics at distribution centers and warehouses can fully automate the process of demanding, receiving, stocking, issuing, and packing items (Li & Liu, 2016). Therefore, IoT-enabled distribution centers and warehouses encompassing robots-based operations with minimal human intervention can improve productivity and lower the costs of any retailer (Chen et al., 2021; Li & Liu, 2016).

D. IOT IMPLEMENTATION FRAMEWORK

IoT technology has created an ecosystem of information sharing through a network of devices, sensors, and software connected through the Internet (Malliaris, 2018). The devices working in the framework of IoT record, process, and transmit information to other devices to achieve specific objectives (Malliaris, 2018). Furthermore, these devices were already present and serving a particular functionality; however, the advent of IoT provided the linkage of these devices through the Internet and enabled them to provide smart solutions by working together in a group (Sharma et al., 2019). A standalone device working within its domain cannot provide as many robust and comprehensive solutions as it can provide by connecting itself to a network of other devices (Al-Qaseemi et al., 2016).

1. IoT Components

IoT technology implementation is dependent upon three main components and is described by Agarwal & Unhelkar (2018) as follows:

a. *Hardware Components in IoT*

The hardware in IoT generally includes physical devices like RFID, computing devices, Bluetooth, cameras, wireless sensor networks (WSN), and the entire web of networks connected through Internet communication platforms (Agarwal & Unhelkar, 2018). The data collected through hardware devices must be uploaded into the cloud servers for subsequent analysis and decision making (Nasser & Soomro, 2015). These hardware devices, like RFID, were already in use by industry before the inception of IoT technologies (Derakhshan et al., 2007). However, the usage of these devices when powered by IoT technologies has tremendously enhanced their productivity, particularly in the age of globalization (Noto La Diega & Walden, 2016; Sharma et al., 2019).

b. *Software Components in IoT*

Hardware devices are of limited use without appropriate software (Ninikrishna et al., 2017). Agarwal & Unhelkar (2018) explained that the software used in IoT provides the main means of communication between the different devices. It enables the users to utilize the hardware devices. IoT-based software can be broadly categorized into middleware and browsing or searching software (Agarwal & Unhelkar, 2018). The middleware is mainly employed by back-end software developers to obtain specific outcomes from the hardware devices in the network. The searching or browsing software is the main pillar of IoT infrastructure, which is utilized by the end-users. The browsing software used in IoT is different from conventional Internet browsers as IoT search software processes at high velocities to deal with dynamic data of devices in motion (Agarwal & Unhelkar, 2018). The information processed by IoT software is rapidly changing, and stability of content is rarely observed (Altarturi et al., 2017). Therefore, maximum efficiencies from the IoT-enabled technologies are dependent upon the efficacy of IoT software (Agarwal & Unhelkar, 2018).

c. *Architecture in IoT*

Agarwal & Unhelkar (2018) highlighted that IoT needs a well-defined architecture of hardware, software, and processes to collect, organize, and represent the information to make informed decisions and achieve required objectives. The IoT architecture defines the

process by which hardware devices interact with peer devices to share information (Al-Qaseemi et al., 2016). Specifically, it defines the protocol of software applications to collect the information and process it into a meaningful result (Choudhary & Jain, 2016). Thus, the IoT architecture determines the processes for utilizing other relevant technologies and embedding them into the IoT infrastructure to yield desired objectives (Al-Qaseemi et al., 2016). Therefore, architecture in IoT plays a pivotal role in its utilization and in addressing various issues arising in the IoT domain (Agarwal & Unhelkar, 2018). Some of the important architectures required for implementation in IoT are as follows (Bayani et al., 2018):

(1) IoT Basic Architecture

An IoT basic architecture can be divided into three layers as shown in Figure 1 (Bayani et al., 2018). These layers can be termed as Perception, Network, and Application layers (Sethi & Sarangi, 2017).

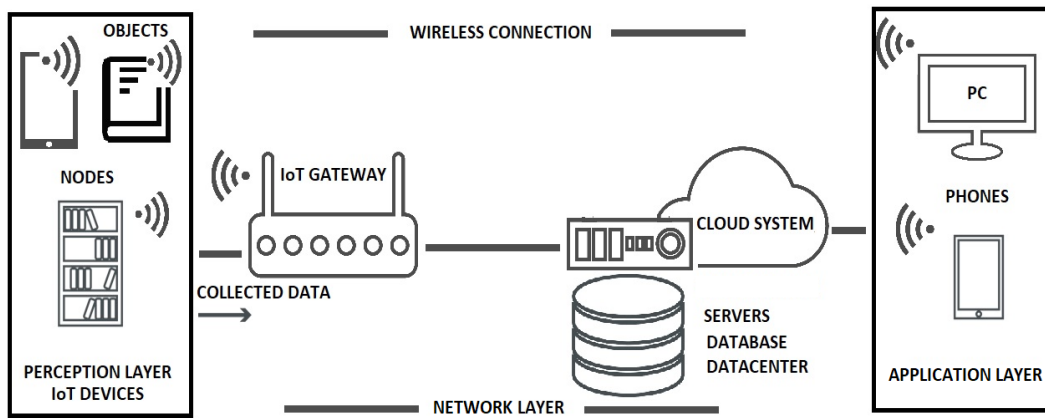

Figure 1. IoT Basic Architecture. Source: Bayani et al. (2018)

The purpose of each layer, as explained by Sethi & Sarangi, (2017) is as follows:

1. The physical layer in an IoT architecture—typically termed the perception layer—contains all the hardware devices like WSN, RFID, and others. The physical layer is the primary source of data collection in IoT architecture.

2. The network layer provides connectivity and serves as a gateway between objects, cable or wireless connections, and cloud servers. The role of network layer is to receive input or sensory data from the physical devices or the perception layer. The network layer is then required to transfer the data to the application layer via cloud systems.
3. The application layer provides the output to users in the shape of valuable information after processing it through various applications and programs.

(2) RFID-Based IoT Architecture

RFID is one of the widely used technologies in retail IoT systems (Kasiri, 2021). It consists of various components that are interlinked to capture data and provide information seamlessly (Mishra & Mohapatro, 2020). As shown in Figure 2, the RFID reader captures data from the tag through the tag processing unit and subsequently transmits data to the server (Bayani et al., 2018).

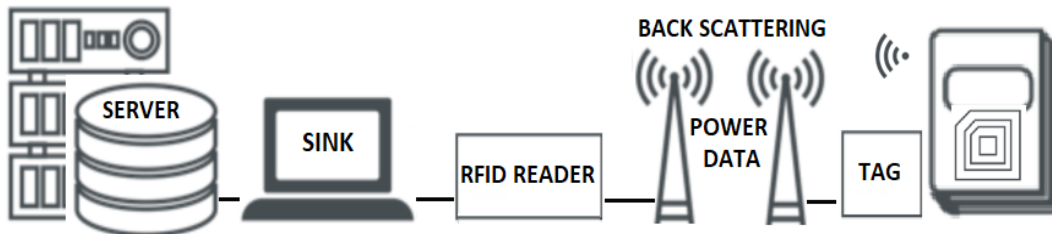

Figure 2. RFID-Based IoT Architecture. Source: Bayani et al. (2018)

(3) Wireless Sensors Network Architecture

In an IoT architecture, WSNs consist of a wireless network, which contains small electronic sensors deployed over a particular region to collect data by sensing and detecting an event (Bayani et al., 2018). The sensory data is then transferred to a base station to monitor and evaluate the event to make a decision based on input data. The WSN, as illustrated in Figure 3, contains green dots representing electronic sensors that are sensing or capturing the data from the red dot representing an event (Bayani et al., 2018). The

sensory data is then gathered at the purple dot representing the base station (sink) to make a relevant decision based on event attributes (Bayani et al., 2018).

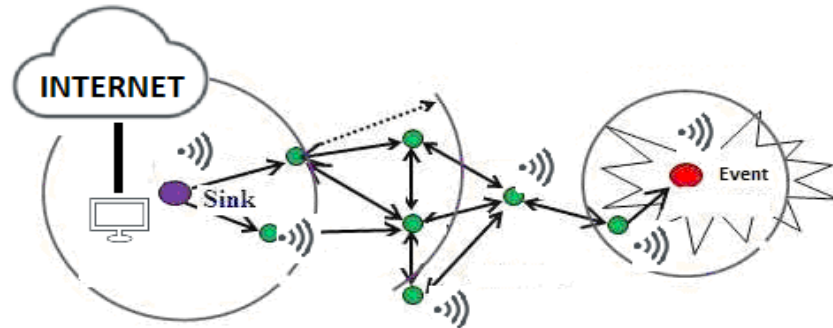

Figure 3. WSN Architecture. Source: Bayani et al. (2018)

2. IoT-Implemented Library System Utilizing RFID and WSN

Bayani et al. (2018) have given an illustration of an IoT-based system in a library that uses RFID and WSN. The implementation of IoT in a library environment provides an excellent practical scenario to understand the implementation of the IoT framework, which can act as a guide for implementation for other organizational setups.

Bayani et al. (2018) have explained that in an IoT-based library administration, a cycle of book circulation can be illustrated as shown in Figure 4. All the books and documents liable to be issued to users receive RFID tags at the tagging area. The RFID tags on the books contain all the information about the book and their storage location, and this information is subsequently used when the book is being issued or returned to the library. Similarly, when users enter the library through an electronic access gate, they are identified by the library through their ID card for various processes at the library (Bayani et al., 2018).

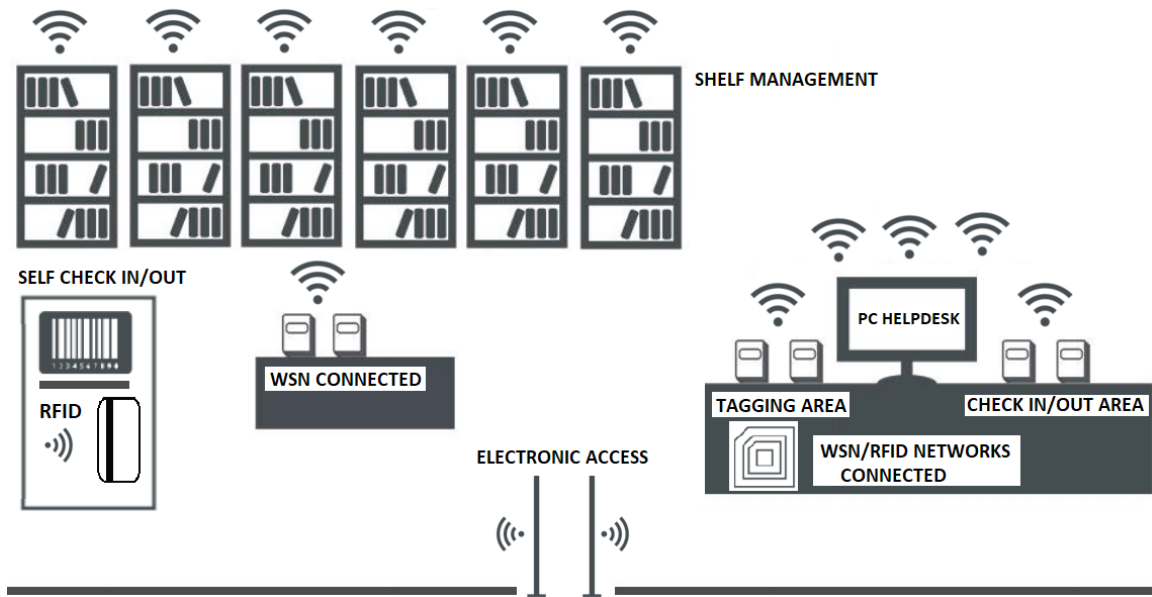

Figure 4. IoT-Based Library System. Source: Bayani et al. (2018)

If users intend to withdraw books from the library, for example, they have two options (Bayani et al., 2018). They could either go to the self-checkout area or they could go to the library staff located near the tagging area to borrow the book. If they choose to go through the self-checkout process, then they can simply scan their ID card along with the RFID card on the book at the self-checkout area. The RFID tag would then communicate with the RFID reader and link the book issuance information with the user ID card on the cloud server. The same process is followed by the library staff while checking out a book. When the users leave the library, they must pass through an electronic access gate, where the sensors would detect the book's RFID tag and the information related to the book carried by the user. If the information of issuance matches with the RFID tag, then the user is authorized to pass. However, if the user has not processed the book correctly through the checkout system, then the sensors would raise an alarm. A similar process would enable users to return borrowed books to the library. Moreover, an IoT-based system enables library staff to perform their tasks more efficiently. For example, they can easily locate a book's shelf information through RFID tag readers and manage bookshelves with much more accuracy compared to manual systems. Furthermore, when the entire process of checking books in and out of the library has been automated with IoT

technologies, library staff members are freed up to attend to other duties (Bayani et al., 2018).

3. IoT Implementation Requirements

The extent of automation in the processes governed by IoT technologies determines the relevant implementation requirements. These requirements are critical to the successful implementation of IoT in any organization. Accordingly, essential requirements are as follows:

a. Security

The security principles in an IoT framework play a pivotal role in its implementation (Udoh & Kotonya, 2018). The security of information collected through multiple hardware devices and software applications connected through the Internet is of paramount importance when privacy, confidentiality, and trust of people is at stake (Lin et al., 2017). Therefore, the IoT framework considers a mechanism wherein the security of information collected from numerous sources is given strategic priority (Al-Fuqaha et al., 2015). Moreover, the integrity of data is also ensured through the security of the mechanism (Lin et al., 2017). If the data can be manipulated without authorization due to compromised security protocols, then IoT operations would not yield effective results as IoT is highly dependent upon the data entered (Udoh & Kotonya, 2018).

b. Adaptability

IoT is heavily dependent upon the connectivity of various nodes to obtain and share information (Bayani et al., 2018). If the connectivity of nodes is compromised, then IoT is unable to operate (Ding et al., 2020). Poor connectivity can result from several factors like power outages, limited Internet infrastructure at various locations, and slower computing speed of various devices in an IoT network (Ding et al., 2020). Therefore, IoT needs to adapt to the dynamic environmental issues by developing capacities of being resilient, self-protective, self-optimized, and energy efficient (Udoh & Kotonya, 2018).

c. Intelligence

Intelligence in an IoT framework is the basic building block enabling IoT technologies to be more efficient and effective than traditional practices (Shafique et al., 2018). IoT-enabled devices and systems must have the capacity to learn and execute independently with such accuracy that human intervention is either negligible or not required at all (Pramanik et al., 2018). Therefore, the IoT framework needs to be equipped with devices and networks having the capabilities to do predictive analytics, behavioral analytics, complex event processing, and context-aware computing (Udoh & Kotonya, 2018).

d. Real-Time Data Delivery

The real-time delivery of data is one of the important aspects in an IoT framework that differentiate it from the traditional approach of data collection (Mishra & Mohapatro, 2020). If the IoT is unable to collect and process data in real time, then the adoption of IoT is not a worthwhile effort (Tran-Dang et al., 2020). Therefore, speed of data delivery is critical in an IoT framework and is one of the most essential requirements (Dlamini & Johnston, 2016).

e. Regulatory Compliance

In an IoT framework, a huge amount of personal data is collected from consumers (Ploder et al., 2021). The personal data could vary from household energy consumption to medical prescriptions (Nasser & Soomro, 2015). An individual's data is considered confidential, and therefore, data collection through an IoT framework demands strict compliance with privacy requirements established according to the location of the user (Udoh & Kotonya, 2018).

E. CHALLENGES IN IMPLEMENTATION OF IOT TECHNOLOGIES

IoT promises numerous automated functionalities and associated advantages; however, there are several challenges in adopting IoT technologies. As an innovative technological solution, IoT demands resources from and commitment by the organizations (Lin et al., 2017). In addition to the cost related to implementing IoT solutions, the

perceived benefits of IoT may be questioned by shareholders, employees, suppliers, and customers, especially if the initial results are not satisfying (Udoh & Kotonya, 2018). Therefore, it is imperative to understand the following challenges when organizations consider adopting IoT technologies. If they are not addressed before or after implementation of IoT, then it is more difficult to achieve potential benefits promised by IoT.

1. Distributed Network

An IoT network is distributed among multiple applications, and each application has system-specific components of various types (Bayani et al., 2018). Each application has its own set of parameters and protocols, which may differ from those of other applications in the IoT network (Choudhary & Jain, 2016). The hardware components deal with real-time data acquisition either through sensors or end-user input on the Web or mobile application interface while the data is accumulated in the cloud (Mishra & Mohapatro, 2020). Similarly, a complex and dynamic IoT network involves a wide range of applications that may be operated in different geographical regions, embedding numerous limitations related to internet connectivity issues, capable human resource, computing infrastructure (Allmendinger et al., 2017). The vast distribution of IoT networks makes it increasingly complex to develop a centralized methodology to deal with all applications involved (Udoh & Kotonya, 2018).

2. Variability of IoT Applications

The variability of IoT applications—such as wireless and fixed networks, Web and mobile software-based applications, and differences in a cloud network—is one of the fundamental aspects that create challenges in synchronizing all IoT applications (Abbas et al., 2017). The variability in IoT application is not just limited to the differences in capabilities, features, and interfaces, however; it is also dependent upon the differences of original equipment manufacturers (OEM), suppliers, and service providers having diverse quality measures and standards of services (Udoh & Kotonya, 2018). Accordingly, these stakeholders may not necessarily communicate and cooperate with each other to achieve standardization of services (Udoh & Kotonya, 2018). Therefore, variability in IoT

applications makes it difficult to achieve synchronization and standardization of output (Bok, 2016).

3. Data Management

The devices in an IoT setup collect data in huge volumes and in several formats (Nasser & Soomro, 2015). This data holds paramount importance as most decisions made by the IoT application are based on the efficacy of data collected and processed (Shafique et al., 2018). Therefore, data collection requires due diligence to ensure it is free from any manipulation by a malicious user, inconsistency of data formats, and slow delivery (Udoh & Kotonya, 2018). As a result, data management poses a greater challenge to ensure that the data collected is valid, reliable, and real-time (Udoh & Kotonya, 2018).

4. Application Maintenance

A wide variety of IoT applications connected with each other through a complex network of devices demands extensive maintenance and technical support (Tran-Dang et al., 2020). In order to maintain the physical devices like hand-held RFID receivers, sensors, cloud servers, and back-end code development and debugging, a diverse team of professionals is required to implement, operate, and maintain an IoT system (Jernigan et al., 2016). Moreover, if the IoT applications are in different geographical regions, then application maintenance can become more expensive and complex if adequate technical expertise and information technology infrastructure is not already available in a particular region (Kuzminykh et al., 2020). Therefore, application maintenance remains a challenging and expensive aspect of implementing IoT (Udoh & Kotonya, 2018).

5. Human-Centric Interaction

Although AI plays a pivotal role in the automation of processes and replaces the need for human intervention in IoT applications, input by humans still plays a significant role (Nunes et al., 2015). The devices and humans often work in synergy to produce and process data (Stankovic, 2014). However, the interaction between humans and devices demands seamless harmony to enable IoT applications to learn and model human behavior (Pramanik et al., 2018). Therefore, it is necessary to design IoT applications that understand

the complex behavioral and psychological aspects of human nature to ensure the validity of data collected from humans (Udoh & Kotonya, 2018).

6. Inter-Dependency of Different Applications

IoT applications are interdependent upon each other, and thus, any conflict in an assumption of one application may result in inconsistent outputs (Munir & Stankovic, 2014). For instance, sensors in a smart home may work simultaneously for multiple applications like health care and energy consumption (Munir & Stankovic, 2014). The integration of these two IoT-based applications is cumbersome to achieve as the real-world assumption of one application may be in opposition to the other application. For example, a healthcare application sensing the user's depression from his lack of movement may respond by turning on all the lights of the house, whereas the energy consumption application would turn off the lights if the sensors do not detect any motion in the house (Munir & Stankovic, 2014). Accordingly, designing the interaction between different applications so they work seamlessly and efficiently in a manner that produces the efficient result poses a significant challenge in an IoT implementation (Udoh & Kotonya, 2018).

7. Stakeholder Concerns

The stakeholders of an organization with varying or sometimes conflicting interests may thwart the successful implementation of IoT (Iqbal et al., 2020). It is pertinent to mention that IoT applications in an organization cannot be adopted in isolation and therefore involve numerous concerns of various stakeholders (Aldowah et al., 2021). For instance, a shareholder may oppose IoT if the perceived financial savings are not achieved even though processes are improved in terms of time savings. Similarly, employees may fear the loss of their jobs due to IoT-based automation of processes (Liu et al., 2018), and customers may be reluctant to share information because of privacy leakages (Lin et al., 2017). Conversely, suppliers and upper management may support IoT applications given enhanced operational performance and visibility (Hicks et al., 2013). Therefore, the diverging views of various stakeholders regarding performance and uncertain financial benefits of IoT are challenging aspects of its implementation (Brous et al., 2020).

8. Quality Output Assurance

The quality of output produced by IoT applications is one of the greatest challenges of IoT applications (Uckelmann, 2012). The output of IoT applications is expected to be flawless as decisions based on this output involves high financial risk (Hwang et al., 2017). For instance, a manufacturing organization relying on an IoT-based demand forecast for its products could risk a significant portion of its production budget (Yerpude & Singhal, 2017). If the demand forecast of such a manufacturing organization is erroneous, the result can ultimately devastate the entire IoT setup with a ripple effect, because no other organization would risk its resources in IoT applications (Yerpude & Singhal, 2017). Therefore, assurance of error-free output and uncompromised quality remain a prominent challenge to IoT implementation (Uckelmann, 2012).

F. INNOVATION IN THE PAKISTANI RETAIL SECTOR

The Pakistani retail and wholesale sector constitutes about 53% of the nation's GDP (Imran et al., 2018). The country's traditional retail setup has been challenged by the rapid increase in technology adoption by the nation's youth, especially during the Covid-19 pandemic (Ali, 2020). These tech-savvy customers are inclined to shop online and are aware of their choices (Rizvi et al., 2019). Nonetheless, many other customers still rely on the physical shopping experience, especially for grocery shopping (Arshad, 2020). Therefore, large grocery retailers with their own chain of stores in the country are highly focused on improving the customer experience in those stores (Irfan et al., 2019). Improving the customer experience through innovative means and technologies, however, is rarely seen in retail superstores (Ali & Xie, 2021). Pakistan's retail managers are mainly focused on improving the supply chain of their products so their stores offer products at lower prices than their competitors ("Pakistan Retail Market," 2021). Moreover, the majority of Pakistani customers lack an understanding of contemporary technologies (Ali, 2020). Therefore, management fears innovating retail processes, which might result in waste of resources and bad customer experience, and has led retailers to adhere to traditional retail practices (Ali & Xie, 2021). These retailers do not consider Pakistan's youth and how quickly and extensively they have adopted new technologies. Consequently,

lack of innovation in retail practices could result in the loss of future customers, and retailers would not be able to sustain their competitive advantage in the long run (Rizvi et al., 2019). Hence, this study contains suggestions on ways to innovate the retail operations of CSD, in particular, which operates in the Pakistani retail sector. that the suggested innovations would enhance the overall customer experience while promising potential cost savings.

IV. FINDINGS AND ANALYSIS

The literature review has highlighted multiple frameworks and implementation guidelines through which CSD retail operations can be innovated through IoT-based applications. Indeed, the existing research has highlighted numerous advantages to implementing IoT applications in a retail setup; however, it is also pertinent to highlight that several IoT applications may not be practical to implement in a business environment of CSD. Based on personal communication with CSD's management, customers, and supplier, and the study of existing literature, the researchers have carried out an in-depth analysis in this chapter to provide a feasible approach to implementing IoT applications in the retail operations of CSD.

A. DOMAINS FOR INNOVATION IN CSD'S RETAIL OPERATIONS

Innovation in CSD's retail operations will have an impact on CSD's identity as a brand and its physical infrastructure. The impact of innovation through IoT-based applications in these domains can be described as follows:

1. CSD's Retail Identity as a Brand

CSD has established itself as a valuable brand in the Pakistani retail market. CSD's managing director (personal communication, November 8, 2021) emphasized that CSD cannot compromise its value proposition of providing low-cost grocery items and friendly service to its valuable customers. Accordingly, CSD's management endeavors to meet the brand's proposition by effectively and efficiently managing its supply chain to ensure the availability of grocery and FMCG items on the shelves. In a competitive retail market, however, CSD needs to focus on the overall customer experience rather than limiting the focus to product availability only. CSD's military customers (personal communication, November 10, 2021) highlighted that CSD lacks in overall customer experience compared to other commercial retail stores. The lack of focus on the broader customer experience stems from CSD's low-cost strategy that demands cost-cutting measures in its retail operations. In order to enhance customer experience and simultaneously its image as a brand while maintaining low-cost retail operations, CSD can adopt innovative strategies

using IoT-based applications. Although IoT-based applications do not promise to improve the overall customer experience per se, they do have the potential to revamp the entire business model of CSD and provide a much better customer experience compared to the existing business model.

2. CSD's Retail Physicality

CSD operates traditional brick-and-mortar retail superstores within the military garrisons of Pakistan. CSD's physical presence has a unique advantage of being positioned among its target customers, i.e., military personnel and their families. The ease of access to CSD's stores located within residential areas of the military garrisons is a great competitive advantage that other superstore retailers do not have. However, that competitive advantage is diminishing with the rise of e-commerce retailing. Therefore, CSD needs to revamp its retail physicality to continue attracting customers to its stores. The innovative ways of improving customer experience at CSD's brick-and-mortar stores go beyond installing extra lighting and centralized air conditioning, hiring helpful store staff, and maintaining neat and clean shelves, aisles, and floors. These are the basic facilities in a superstore that CSD cannot claim as a competitive advantage that provide a significantly better customer experience. Therefore, there is a need to innovate the physical aspects of CSD's retail outlets in a way that aligns with CSD's low-cost model and provides a better customer experience compared to that of its competitors. Accordingly, IoT applications can pave the way through which CSD can capture greater competitive advantage and lay the foundation for an innovative retail experience in a Pakistani retail market.

B. ANALYSIS OF IOT APPLICATIONS FOR ADOPTION AT CSD'S RETAIL OPERATIONS

Numerous IoT technologies can be adopted to innovate CSD's retail operations. However, it is imperative to understand that every IoT application has its unique architecture and framework for implementation. Therefore, this study has focused primarily on IoT-based applications suitable for a Pakistani retail environment, and the feasibility of their implementation is analyzed in particular based on CSD's infrastructure,

resources, capacities, and organizational culture. Accordingly, the following IoT-based applications are analyzed for adoption in CSD's retail operations at its superstore at Rawalpindi only.

1. IoT-Based Store Layout

Using IoT at its superstore at Rawalpindi, CSD can optimize the store's layout. The observations of the researchers as regular customers of CSD and their discussion with CSD's managing director (personal communication, November 10, 2021) revealed that there are no sensors and movement detectors at the store that can track customers' movement within the stores. The store layout is designed based on the categories of grocery items without consideration of any optimization of store layout based on high sales of items and customer foot traffic. With IoT technologies, CSD can use the feed from different sensors installed in the store to determine how to optimize the store layout by tracking customers' movement within the aisles.

Heat sensors can detect the movement of customers in a store, and, based on the data collected, CSD can showcase its promotional products in the areas most frequently visited by customers. The placement of promotional products themselves may not attract greater attention to their aisles or shelves compared to their placement in the areas of the store that already attract high customer presence. By moving the promotional items to these high traffic areas, CSD can optimize store layout and increase sales volume. Moreover, the heat sensors can also be linked to the different utilities in the store to optimize their utilization. The areas in the store where fewer customers are observed may have reduced need for bright lighting and cooling/heating. The study revealed that data on customer movement could provide feedback to the utility control panel, and the lighting and cooling/heating could be adjusted in different areas of the store according to customer presence. This would result in significant cost savings on utilities without compromising customer experience.

The installation of heat sensors to track customer movement seems challenging and complex and demands significant resources. Nevertheless, the potential benefits and cost savings seem to outweigh the implementation issues. If the installation of a swarm of heat

sensors for tracking customers' movement within the store would require high acquisition and maintenance costs, there is an option to install small trackers in shopping carts instead. The study revealed that these trackers can utilize either RFID (Newberg, 2020) or Global Positioning System technologies (GPS; Live View GPS, 2015). The trackers can send direct feedback on shopping cart movement within the store to the back-end server as soon as movement is initiated (Newberg, 2020). Subsequently, an IoT-based software application fetches the same feedback from the server to determine the number of shopping carts within a specific area of the store; this information could be used to make decisions about future promotional product placement (Newberg, 2020) and can also be utilized for automated lighting and heating/cooling within the store. These trackers can also provide feedback to CSD's management about the specific route from entrance to check out that the majority of the customers take in the store. The most traveled route in a store can be further optimized according to the business needs. Moreover, to lower costs related to the loss of shopping carts, the wheels of the carts may be programmed to jam as soon as the cart leaves a defined area outside the store.

2. Automated Checkout at CSD's Store

IoT-based applications provide an opportunity for CSD to establish automated checkout at its Rawalpindi store. According to CSD's customers (personal communication, November 10, 2021), it is frustrating to shop at CSD's Rawalpindi store during the beginning of the month. The main reason for such frustration is long lines at the checkout counters. The customers waste their time in lines waiting to process their payments, which contributes to a negative shopping experience at CSD. The matter was discussed by the researchers with CSD's managing director and store manager (personal communication, November 8, 2021), and they highlighted that CSD has already invested heavily in establishing numerous checkout counters at Rawalpindi, and cashier staff is also trained to process each customer's shopping cart in the shortest possible time. Nevertheless, the number of cashiers and counters at the Rawalpindi store cannot cope with the demand at the beginning of the month as per the CSD's management feedback. The management realized that lines of customers would form at the checkout counters, but management could not install any more counters because doing so would increase their operating

expenses. In this regard, IoT-based applications offering automated checkout would reduce the workload on checkout counters and would also enhance customers' experience, as they would no longer have to wait in lines to make their purchases.

At an IoT-based automated checkout counter, CSD customers would have to enter a small passage-shaped counter installed with two small doors of sensors. The customer would have to tap his or her debit/credit card at the first door to open the automated checkout counter aisle door. As soon as the customer would enter the passage, the first door of the sensor would close to enable the processing of a single customer at a time within the automated counter. Subsequently, the customer could then pass through a series of sensors, which would automatically detect all the items in the customer's shopping cart at once without requiring the customer to scan each item individually. The gate of the sensor would have the capacity to scan the RFID tags of each item in a cart; transfer the price, weight, and quantity information to the back-end server; and process payment from the customers' debit/credit card within seconds. If no payment error would occur, the second door would open, and the customer would be able to leave quickly. Installing the automated checkout counter would allow customers to leave the store without waiting in line for the checkout counter.

Since CSD operates in the Pakistani retail market wherein the majority of customers prefer to pay in cash instead of debit/credit cards and mobile payment apps, holistic adoption of an automated checkout system may not be well received by the cash-paying customers, and the system might fail as this study noticed. Therefore, CSD would have to adopt this IoT-based automated checkout system in conjunction with the traditional checkout counter system. The system would work in a way that customers willing to process their shopping carts through traditional checkout counters would have to follow the existing practice of paying for their purchases through cashier staff at the counter, while the tech-savvy customers savvy willing to process their payment with a debit/credit card would be able to go through automated checkout counters without any wait time.

The significant potential benefits from implementing an IoT-based automated checkout counter at CSD include improved customer experience, as the wait time for customers passing through automated checkout counters would be negligible if multiple

automated checkout counters were installed. Since the customers processing payment through automated checkout counters would be diverted from the traditional checkout counters operated by cashier staff, the wait time at those counters would also likely decrease. The other benefit that CSD could achieve in the long run is that if more customers prefer to go through an automated checkout counter, then CSD can reduce its labor costs related to cashier staff. In a fully automated checkout system, CSD would not need any cashier staff to operate a traditional counter.

Indeed, automated checkout counters present promising potential benefits in terms of improved customer service and experience as per this study. On the other hand, they are also likely to get resistance from the CSD store's staff and customers. From the customer's perspective, the adoption of a new process, although quite simple, would raise concerns of trust and security. The customers might not trust the system while going through automated checkout counters, as they could not observe the processing of their shopping cart through their own eyes. Similarly, CSD's floor management might not trust the entire process of the automated checkout system without human intervention. These trust issues can be further aggravated if the accuracy of the automated checkout counter is compromised. Furthermore, employees who fear losing their jobs might not support its implementation. The extent of automation that delivers much more accuracy, speed, and reliability may challenge the traditional retail practices being followed by the employees and may require their learning new skills to deal with such automation. Therefore, prior to the implementation of the automated checkout counter, CSD's management needs to mitigate these potential issues.

The implementation of automated checkout counters should likely be incremental to anticipate and address any potential issues effectively. As discussed earlier, given the Pakistani customer cultural norms, CSD could initially install two automated counters at the Rawalpindi store. These two counters would then be tested by the store staff to check their reliability and speed. Moreover, CSD's management would also need to communicate to the store employees that this automation would not affect their jobs; instead, it would ease their jobs. Support from the store employees is necessary; if such support from employees is not mustered, then there is a possibility that even the initial system might fail.

Subsequently, after the automated checkout counter's reliability and accuracy prove trustworthy, these counters can be made available to customers. In order to promote the usage of the new system, CSD could offer discounts and help to customers willing to use the new technology. Eventually, when the percentage of customers using automated checkout counters begins increasing, the number of automated checkout counters could be increased, and the number of traditional cashier-based counters could be decreased.

3. IoT-Based Map of CSD's Store

IoT-based store maps can play a substantial role in improving customer experience and sales of CSD. According to most CSD customers (personal communication, November 10, 2021), it is very frustrating to locate items at CSD's megastore. Moreover, there is not enough staff to ask where items are placed within the store. Consequently, CSD's customers either buy the item from another retail store or shift to another brand of the same product. Management stated that CSD groups different types of products by category. For instance, all toiletries will be placed together in a group of aisles. However, the customers may have a different expectation about how an item should be categorized or with what other products it should be placed. Moreover, even if the customer can locate the correct group of aisles assigned to some category of products, it is sometimes difficult to locate the specific stock-keeping unit (SKU) of an item in the presence of thousands of items placed together in the group of aisles. Therefore, a customer at CSD frequently needs staff assistance to locate a specific item. CSD's managing director (personal communication, November 8, 2021) highlighted that customers usually need direction when they are either new to CSD's store layout or trying a new product. The managing director also highlighted that there are cases when regular customers also need directions to locate specific items when the store staff has moved items to other aisles due to space constraints or other issues. Both CSD's management and customers pointed out that store mapping is one of the greater concerns affecting customers' experience and CSD's bottom line. In this regard, IoT-based technological solutions could help to create a better customer experience and support a stronger financial stream for CSD.

Using an IoT-based store mapping system like SmartMart discussed in Chapter III of this study, CSD could develop an interactive mobile phone application that captures real-time data of all items present in its Rawalpindi store through RFID tags placed on the items. With the mobile application installed, whenever customers needed guidance to locate a specific item aisle, they could simply enter the item's description in the search bar, and after fetching information from the CSD's server linked with the RFID tags on items and aisles, the app would give the specific location along with the highlighted route to that location within the store using the IPS. Following the route, the customer would easily reach the destination of the item without bothering any store staff. Moreover, the mobile app could also display the price of the item and any discounts. If a customer enters his or her grocery list into the app, it could also suggest the shortest route to pick up the items from different aisles. Using a queuing theory model, the app could also notify the customer of the estimated wait time at the checkout counters at any given time so that customers could plan their visit to CSD at their convenience. Accordingly, other IoT applications may be linked with this app to facilitate an enhanced shopping experience for customers and subsequently improve sales.

Introducing a store map through a mobile application would enhance customer experience, and the loss of sales due to difficulties in locating items within the store would be eliminated. Moreover, CSD could also save on potential labor costs, as the store staff who currently assist customers in finding products in the store would no longer be required. As already explained, customers could spend less time in the store if they entered their entire grocery list of items prior to coming to the store, but this has advantages for management as well. The list of items would also alert CSD's ERP about the potential purchases of the items. The data per se would ultimately help in making inventory procurement decisions well in advance, compared to the existing ERP systems getting feedback on sales data from the POS. Moreover, CSD could save a lot of time and make timely procurement decisions even before sales occur, with the data being fed from the CSD store map mobile applications to the CSD's computing servers.

The development of a mobile-based application and its subsequent network with ERP, RFID system, and IPS would be a challenging aspect that needs consideration before

its implementation. The software protocols and database management of these platforms would be unique and would require a complex architecture to work synchronously. If the app were unable to establish the connection with the RFID systems to fetch the real-time location of an item, then the mobile application would not yield its potential benefits. Moreover, management would also need to know the actual percentage of sales deviation from intended purchase items marked by the customers in the mobile application, as there is a possibility that the customers might add numerous items to their grocery list in the app, but might change their mind in the store and buy another item instead. Moreover, there is a possibility that most customers would not use mobile apps to locate the items at the CSD store. Accordingly, CSD would then have to place certain store staff on the floor to guide such customers. Consequently, procurement decisions would not solely depend upon the mobile application-based forecast for items. Given that consideration, a complex algorithm backed by the machine learning capability of the system would be required to base the final demand forecast of products.

An IoT-based store mapping system could be implemented at CSD with a major focus on giving guidance to the customer in locating different items within the store so that the tech-savvy customers could help themselves. At the same time, CSD could substantially minimize the store staff needed on the floor to guide customers who are not interested in using the CSD store map mobile app. When management observes an increase in the rate of mobile app usage to locate the items within the store and greater percentage of sales driven by a customer's intended purchase list on the mobile application, then it would be feasible to eliminate store staff on the floor and calculate the demand forecast based heavily on mobile application data.

4. Smart Shelving at CSD's Store

IoT applications can help to turn CSD shelves into smart shelves that both house items and act as a data collection point to forecast demand. OSA is one of the primary concerns of any retailer: if items customers want are not available at a retail store, then it could result in a bad customer experience and loss of sales (Caro & Sadr, 2019). According to CSD's managing director (personal communication, November 8, 2021), CSD has a

sophisticated procedure to ensure the OSA of an item. In the demand forecast process typically used by CSD, the sales data at the POS of each item is transferred to the CSD's ERP. The sales data of an item is obtained from all CSD stores and then the accumulated order is placed with the manufacturers and distributors of the item. The managing director highlighted that while placing orders with the CSD's suppliers, the procurement managers use their judgment about future consumption based on past consumption trends. During the discussion, managing director did not highlight any mathematical model of forecasting used for demand determination. The model of demand determination and order placement is indeed effective, and CSD is able to meet customer demands with much efficacy from management's perspective. It is imperative to judge the same model from the customer's perspective. CSD's customers (personal communication, November 10, 2021) highlighted that CSD has less variety of items at its Rawalpindi superstore compared to the variety of items at the commercial supermarkets. Less variety of items leads to the assumption that CSD indeed ensures OSA of fast-moving items; however, CSD does not maintain OSA of numerous products that have low customer demand. CSD's customers expect to buy all kinds of items under the same roof. This does not necessarily mean that CSD should store excessive inventories on its shelves, but CSD's management must understand that the needs of each segment of its target customers are being fulfilled. If a certain lower-demand item qualifies to be on the shelf of CSD based on the demand of a particular customer segment, then CSD must consider the demand of said item closely. Moreover, there is also a possibility that CSD's existing demand forecasting model is flawed, based on which items are not available when needed by CSD's customers. It is also possible that when CSD allocates more shelf space to the items with high demand, there is either less or no space left for the items with low demand. Therefore, efficient shelf management encompassing demand levels with high variability is critical to enhancing the overall customer experience and reducing the number of lost sales. In this regard, IoT-based smart shelving can help CSD to address this issue and improve its customer experience.

With IoT-based smart shelving, CSD can obtain data directly from the smart shelf instead of waiting for the sales data to consolidate at POS. Following the model proposed by Vargheese & Dahir (2014), CSD can implement IoT-based smart shelves. According to

the model, sensors could be installed on store shelves, allowing numerous items to be scanned through RFID tags. As soon as the item is picked up by the customer, the scanner observes the movement of items and relays its feedback to the back-end servers. The servers would then send the data to the sophisticated IoT-based software using machine learning protocols that would analyze the stock position of items at various points (i.e., shelf, warehouse, distribution center, and transportation). Accordingly, the sophisticated software would then alert the managers as soon as the stock falls at or below the reorder point (ROP) set by the system based on past data of supply lead times, demand, seasonality, and customer service level. The software would also be able to suggest a suitable forecasting technique having fewer forecast errors for each type of item, as applying a single forecasting technique for all categories of items is not reasonable. The real-time alerts would help managers in the timely ordering of items instead of manual review of sales data. The automation of capturing inventory data would make the process seamless and would also help CSD to share the same information with its suppliers so that they could adjust their production plan with a real-time data feed.

The IoT-based smart shelving would help CSD to maintain a large variety of items without facing a stockout situation. CSD's customer experience would also improve, as CSD would be able to meet the demand of each segment of its target customers. The forecast based on a machine learning algorithm encompassing several factors (e.g., trends, seasonality, inflation) in an IoT-based application is expected to be much more accurate as compared to existing judgmental forecasting that relies solely on past sales data. CSD would be able to maintain adequate safety stocks as per the requirement without piling up huge inventories to meet unforeseen demand. Thus, CSD would be able to decrease its inventory levels without compromising its level of customer service. This would result in huge cost savings, as the majority of investment in inventory would decrease.

The implementation of smart shelving at CSD would be challenging and complex. CSD would have to develop the entire infrastructure from smart shelving to order placement to suppliers. After the development, the upgrade of the existing ERP used by CSD or development of a new one would also pose great challenges. Subsequently, the relevant expertise to maintain the entire smart shelving models and training of managers to

use the new system would also be required to ensure successful implementation and operation of the system.

The challenges and complexities of IoT-based smart shelving could be navigated if its implementation were given strategic importance. Therefore, successful implementation of IoT-based smart shelving to maintain OSA would depend upon the acceptance of this innovative system by upper management. If upper management supports the idea of installing smart shelving at CSD and realizes the potential benefits of the same, then it would be possible to generate a successful system with adequate resources. Since it is a revitalization of the complete system, abrupt implementation is not recommended. At first, CSD's management would have to develop a prototype of smart shelves and an associated system of networks. Afterward, management would have to observe its result from end-to-end. If the results are promising, and potential savings are projected to be huge, then the resources may be allocated, and development of the system may be initiated and further linked to CSD's ERP.

5. IoT-Based In-Store Promotion at CSD's Store

IoT-based in-store promotion could boost sales at CSD compared to the existing method of placing banners and discounted price tags on aisles and shelves. During the researchers' discussion with CSD's managing director (personal communication, November 8, 2021), it was revealed that CSD has no specific strategy to address promotion to individual customers. Instead, the promotions are offered to any customers who wish to take advantage of them. By contrast, IoT-based in-store promotions using beacon technologies could enable CSD to send personalized promotional notifications to customers' mobile phones along with other in-store promotions. In said system, as soon as a customer reaches CSD's vicinity, his or her mobile phone would define the customer's shopping preferences based on past purchases from different online apps. As soon as the data is received at beacons installed at the CSD store, the algorithm would analyze the customer's interests and relevant products in the store that would be of interest to customers. Accordingly, if the algorithm suggests that the items can be offered at a discount to specific customers, then the customer would receive notification of discounts with a

specific numeric or quick response (QR) code. The customer would then be able to take advantage of a certain discount by using the unique numeric or QR code on specific products of their interest. The highly personalized in-store promotion can be made possible through the implementation of an IoT system. Accordingly, the improved customer experience would be followed by higher sales volume, as the discount would most likely be taken due to the customer's preference. Since CSD operates in a Pakistan where customers are not usually ordering items through online apps, a rich history of shopping preferences cannot be determined to offer relevant products of interest to customers. Since CSD deals with grocery and FMCG items, suggesting such items at lower discounts to specific customers would also not make a great difference in sales. CSD can utilize this technology to offer discounts on new brands or a variety of grocery items that CSD's customers might want to try if available at a discount. The IoT technology cannot promise high potential benefits on grocery or FMCG items unless CSD introduces its online shopping mobile application and maintains a record of customers' interest data. However, CSD could use this technology for electronic or clothing items at its store, a topic beyond the scope of this study.

6. Digital Price Tagging at CSD's Store

The digital price tagging on items at CSD's Rawalpindi store can be integrated with IoT applications to yield cost-effective price tagging. CSD's managing director (personal communication, November 8, 2021) highlighted that price tagging is a laborious and costly activity at CSD. The time and cost are further increased when management decides to offer promotional discounts on products. Usually, the price tags are pasted at DCs of CSD. If a particular store wants to get rid of existing stock to make space for the new stock or there are any other issues arising due to perishability, expiration, or deterioration of stock, management usually decreases the price of an item in order to increase the demand for that item. These promotional efforts require changing the price tag of an item, as it serves as the main advertisement on the item itself. When customers see a price tag showing a lower price than the previous higher one, then customers realize that they are getting more value from that item. Therefore, CSD's management carefully considers correct price tagging of

items, and it is usually a routine activity in the presence of thousands of items in a superstore.

Digital price tags can provide a cost-effective and efficient solution to eliminate the routine laborious activity of price tagging. It is pertinent to highlight that digital price tag devices, if managed manually by inserting/changing the price on each device, would not serve the purpose of time and cost minimization. Therefore, to yield potential savings, digital price tagging devices must be managed centrally through IoT-based applications. Accordingly, in IoT-based digital pricing, all the devices are connected in a network to a server giving its feed to the IoT-based software applications. In this system as soon items are received at CSD, an RFID tag including relevant price details of the items would be pasted on each item. The RFID tag information would then be transferred to the server and IoT-based application. Management could change the prices of the items in the IoT-based software by simply typing the new price within seconds and subsequently the price change would be reflected on digital devices placed on the shelves. This results in huge cost savings, as management would save numerous labor hours deployed in placing price tags on the items. Moreover, management could easily offer discounts on the items with low shelf life in just in time.

Digital price tagging and its associated IoT-based ecosystem would be challenging to implement. The sourcing of digital tags having network capabilities would be difficult and might result in higher costs, as there is no retailer in Pakistan that has the same provision, according to the CSD's supplier (I. Khan, personal communication, November 9, 2021). Therefore, identifying and locating a reliable manufacturer/supplier in the region that can provide such digital tags would be CSD's priority before considering digital price tagging. If a reliable manufacturer agrees to provide the same and guarantees its integration with CSD's IoT system, then management should implement it incrementally to determine the potential issues in the pilot system. If the pilot system of digital pricing proves to be successful, then management should train the employees on the system and the storewide implementation may be carried out by CSD's management.

7. Smart CRM at CSD's Store

IoT-based applications can work in a variety of ways to support CRM at CSD. In this regard, CSD's customers (personal communication, November 10, 2021) highlighted that CSD does not have a specific CRM department and customers' voices are often unheard. The only chance that customers get to convey their suggestions to management is either by phone or via cashier staff at the checkout counters. Moreover, the staff is also not adequate to assist the customers within the stores during peak periods. Indeed, management is trying its best to provide a better customer experience at the store within the resources and established procedures; however, the resentment of customers resulting from negative shopping experience due to insufficient staff to assist would rise with time due to increased competition in the retail sector. In view of the present situation, CSD's management can either establish a separate CRM department and staff it with an adequate number of employees, or management can venture into IoT-based applications encompassing sophisticated AI systems. The IoT-based CRM would not only enhance the customer experience, it would also work in a manner to increase sales and generate personalized promotions for the customer.

In an IoT-based CRM, automation of processes will play an integral role in enhancing the ultimate goal of improving customer experience. At the floor level, multiple cameras driven by AI technology would detect the customer's facial expression on the floor. As soon as the camera detected a customer with a confused facial expression, it would trigger the system (Bok, 2016). Management would then send a store staff member to assist the customer and, if the customer needs assistance, he or she would be highly satisfied with the responsive customer service. If the customer did not need assistance, then at least it would be clear that the perplexed facial expressions of the customer were not driven by CSD's shopping experience. Moreover, the cameras placed at the different aisles, shelves, and corners would also help to determine the shopping behavior of the customers by capturing facial expressions and time spent by the customers at CSD. Management can draw relevant insights from such data about customer buying patterns and interests and subsequently devise strategies to attract more customers by offering personalized promotions based on customer interests. The AI system would detect the products that

CSD's management offered on promotional discount and would send emails/text messages to the customers most likely to buy based on their buying behavior. CRM can be implemented in terms of offering a mobile application that customers can use to raise their concerns/complaints and offer suggestions instead of contacting management via phone calls. Since customers are already using smartphones for many tasks, smart CRM is expected to receive more feedback from the customers via mobile applications instead of phone calls. Similarly, numerous other processes can be automated through AI-driven IoT-based applications that CSD can further tailor after the implementation.

IoT-based CRM offers numerous advantages to CSD. Presently, store staff is deployed at the CSD store to assist customers; however, the number of staff is insufficient to assist all customers in a timely manner. The AI-based facial expression recognition would generate a targeted list for the store staff of customers who are potentially in need of assistance. This would help CSD's staff in assisting customers when needed instead of wasting time by asking random customers whether they need assistance while shopping in-store. Moreover, AI-based systems would also enable CSD to offer highly personalized promotions to the customers as per their interests to boost sales. At the same time, a mobile application would also generate significant amounts of data in terms of complaints and suggestions from which CSD's management could then draw insights and work on relevant solutions to improve customer experience. Hence, automated CRM would result in greater customer experience, and management would be able to create a unique competitive advantage through its automated IoT-enabled CRM practices.

The potential issues related to the implementation of highly sophisticated AI-based systems and mobile applications are the development cost of such technologies. Although the potential benefits are greater in terms of customer experience and boosting sales, these benefits may be compromised if the technology is not developed at par with the requirements. In order to develop, implement, and maintain such AI-based infrastructure linked with IoT-based hardware and software, relevant expertise would also be required, and that would further increase the cost. The managing director of CSD (personal communication, November 8, 2021) revealed that CSD has already established a reliable and highly sophisticated IT infrastructure. Therefore, if the IoT-based AI technologies were

developed, then CSD would have the expertise and resources to maintain the system. Yet, the development of such a system would be a challenging project due to issues like the hiring of a relevant professional IT team with the requisite skills in AI-based software developments. Accordingly, CSD could develop such a system at a very small scale and with minimal resources. If the developed system promises perceived benefits, then CSD can implement the system at full scale.

8. IoT-Based Distribution and Retailing for CSD

IoT-based distribution, transportation, and warehousing would result in better OSA and high cost savings. CSD's managing director (personal communication, November 8, 2021) explained that CSD follows the traditional distribution system for online and in-store customers: items are shipped to CSD's DC and then shipped to CSD's retail stores for subsequent sale to in-store customers and online customers. The orders for online customers are picked from CSD's in-store shelves. There is no facility for customers to do curbside or in-store pickup. The customer either picks up items from shelves or processes an online order, which is delivered to them at their home address located within the boundaries of the city. The managing director (personal communication, November 8, 2021) highlighted that those online customers' sales through CSD's website account for only 5% of CSD's sales. No dedicated efforts and distribution system were established to cater for such low sales volume. The online deliveries are made by third-party transportation companies, and CSD charges its customers the delivery costs it incurs from the transportation companies. Online sales volume will likely increase in the future due to increased online shopping (Rizvi et al., 2019). Therefore, CSD must establish its omnichannel distribution system to cater to online and in-store customers. In this regard, IoT-based applications encompassing AI, robots, and GPS-enabled digital devices can entirely transform the retail practices of CSD. The omnichannel distribution of CSD would be almost fully automated to ensure efficient and cost-effective retail operations.

In an IoT-based setup, CSD would have to establish a robotics-based warehouse adjacent to the Rawalpindi store. The warehouse would act as a DC for the online sales as well. Instead of manually picking and stowing the items in the warehouse, small robots

would do the same and move the items through sensor-based conveyor belts (Yudiansyah et al., 2020). Amazon's fulfillment centers have the same robotics-based technologies (Yudiansyah et al., 2020). CSD can follow the same methodology as that of Amazon's fulfillment center. As soon as the item is received at the gate of the warehouse, it would be picked up by the automated forklift, which would be programmed to place a group of items on a conveyor belt. The items packed in bulk cartons and determined by the system to be stowed in bulk cartons within the warehouse would then move toward a certain area of the warehouse on a conveyor belt with highly integrated guidance of sensors installed along the way. After reaching specific locations, a swarm of mini-robots would then take the boxes. Depending on the weight, size, and volume of the carton, the relevant robot would be assigned by the AI system to pick up the carton and place it in the system-defined storage place. Similarly, the items required to be stowed in individual packing instead of bulk package storage would be sorted out manually at the initial receiving station and then placed on conveyor belts that move the item to its specific location; this would be followed by robot pickup. This would be a procedure to store the items in a warehouse to meet the demand from in-store and online customers. Accordingly, CSD would also have to develop the online shopping mobile application with features for home delivery, curbside pickup, and in-store pickup. As soon as the demand signal is received in the warehouse, the dedicated robots would pick up the items and place them on a conveyor belt. The conveyor belt would then transfer the item to a specific bin where all the items for individual orders would be accumulated and packed manually by the store staff. The store staff would also act as a quality check that all the items in an order are picked up and that there are no quality issues with those grocery items prone to deterioration. The package of items would then be transferred to the conveyor belt, and the belt would further move the package to the system-defined transport bay area. All the packages to be delivered to a specific location would be allotted relevant means of transportation. The delivery trucks, vans, motorbikes, and other vehicles, would be guided by a sophisticated AI system recommending drivers follow a specific route to complete deliveries. The AI system would maintain the data from a GPS installed on CSD's trucks and from various other online maps to suggest the fastest route, as followed by UPS for parcel deliveries (Holland et al.,

2017). Following the same principles of UPS, CSD can also direct its delivery drivers through the use of AI-based IoT applications. The route suggested by the AI system would help to deliver all packages in less time and with greater fuel efficiency, thus enabling CSD to offer free delivery of items within the city. Customers would also be given the real-time feed on the processing of their order, including the recent location of their package, on the mobile application. Hence, CSD would be able to fulfill the demands of online customers with a highly automated distribution system and deliver a better customer experience.

The automated warehouse would also support the in-store replenishment of stock and curbside pickup by the customers. For curbside and in-store pickup of items, the system would work as follows: as soon as the order is received in the system, the robots, conveyor belts, and manual quality check described previously would be carried out, and the items would be sent manually to the in-store pickup counter or delivered to the customer at curbside. Similarly, the system would also fetch data from the smart shelves located in-store. As soon the stock reaches or falls below ROP to the warehouse, the data would automatically transfer to the warehouse IT system, and the subsequent actions of robots, conveyor belt, and manual quality check would take place, and the items would be delivered to the store staff for replenishment of stock.

Automation at the warehouse and AI-based omnichannel distribution promise numerous advantages and potential benefits of cost savings as per this study. The system would significantly reduce labor costs and enhance the performance of CSD. If CSD develops trust among its online customers by delivering quality items through same-day service, then CSD can attract a huge customer base and demand would increase dramatically over its in-store demand. If CSD establishes such a system and promotes its offering to a target customer base in an efficient manner, there is no doubt that CSD could become a market leader in the online grocery delivery business.

The IoT-based warehousing and its associated distribution strategies would be highly challenging in terms of acquisition aspects. The acquisition of robots for warehouses, sensor-controlled conveyor belts, highly sophisticated AI-based ERP, and the transportation fleet would require enormous investment. The maintenance costs of such infrastructure would also be a great burden on CSD's balance sheets, until CSD captures a

significant market share in online retailing. The automation of processes would also create job insecurity for some CSD employees, and opposition to automation might result in an unsuccessful venture. Automation would entirely change the business model of CSD, and therefore, the automation of processes should be undertaken with a strategy that mitigates the odds of failure.

CSD's management would need to have ascertained the potential online demand of grocery items, especially in Rawalpindi city, prior to introducing full automation of the warehouse and distribution. The calculation of the normal online demand market and a potential increase in demand if CSD offers quality grocery items at discounted prices and same-day, free delivery services would require extensive research, surveys, and focus group interviews/discussions. If the detailed research reflected that the customer demand would likely increase significantly and the potential sales volume would surpass existing sales to a great extent, then CSD could initiate the development of such an automated system and implement it incrementally. If the initially developed pilot system resulted in the creation of huge demand, then the system could be rolled out with full funding and resources to complete the building of such infrastructure. In this regard, the employees' resentment stemming from the fear of losing their jobs might be mitigated by the fact that the automation would also open opportunities for online customer segments, and the employees would still be needed to ensure quality as entire retail operations would not be solely dependent upon automation.

C. INTEGRATION OF FEASIBLE IOT-BASED SOLUTIONS AT CSD

There are numerous ways for CSD to adopt IoT applications in innovating CSD's retail operations. In this regard, CSD can adopt and implement any of the IoT applications discussed previously through existing IoT applications as identified in Table 1. The cross mark (✕) in each box represents the perceived potential benefit, shown in the first row of this table, that would come from adopting an IoT-based application strategy listed in the left column. The right column of this table represents the available technologies, which CSD can consider adopting with minor tweaks as per CSD's business requirements.

Table 1. Existing IoT Applications. Adapted from Bok (2016).

IoT Based	Ease of Shopping	Product Availability	Marketing	Data Analytics	Cost Savings	Existing Application
Store Layout	✗		✗	✗	✗	Euclid, ShopperTrak, Aurora
Automated Checkout	✗			✗	✗	MagicBand, Verifone, Beanstore POS
Store Mapping	✗		✗	✗	✗	SmartMart, Linea Pro-4
Smart Shelves	✗	✗		✗	✗	Kaa Power Shelf
In-Store Promotions	✗	✗	✗	✗		iBeacon VMware
Digital Price Tagging	✗		✗		✗	Electronic Shelf Labels (Pricer, n.d.)
Smart CRM	✗	✗	✗	✗	✗	Combination of almost all abovementioned technologies
Robotics Warehouse and Distribution	✗	✗	✗	✗	✗	Kiva (Yudiansyah et al., 2020), ORION (Holland et al., 2017)

CSD can also adopt several IoT applications simultaneously and integrate them in a manner to get maximum potential benefits and cost savings. In this regard, if CSD plans to adopt all the previously discussed IoT applications simultaneously, then the resultant IoT-based CSD retail practices would be developed by CSD’s management through IT professionals and SMEs. The system would be primarily built upon integrated software, hardware, and architecture.

1. Software

In an integrated setup at CSD, almost every IoT application would require a mobile application for CSD’s customers. Presently, there is no mobile application for CSD’s customers. Therefore, CSD would have to develop a mobile application for smartphone

users, having the features of online shopping with home delivery, curbside pickup, and in-store pickup. The mobile application would also require customers to set up an online account with CSD and get it scanned at the automated or manual checkout counter so that CSD can track the customer's preferences and interests and send personalized promotional discounts. The mobile app would also help with in-store mapping in case the customer needs to know the location or price of a specific item. Finally, the app would serve as a platform to receive customers' complaints and suggestions. Moreover, CSD would need to build comprehensive software that CSD's management would use to receive real-time data from various hardware devices and make decisions based on this real-time data. The software would act as a source to give directions to the entire IoT system and would also reflect different decisions undertaken by AI. Hence, sophisticated software having features to integrate all IoT applications and then represent information in such a manner that would enable CSD's management to make informed decisions would play a critical role in the successful implementation of IoT-integrated applications.

2. Hardware

Hardware devices like RFID scanners, robots, conveyor belts, and sensors would be required to implement an IoT-based store layout, smart shelves, digital pricing, automated checkout, etc. These hardware devices programmed to obtain the relevant data from customers, the environment, and items themselves, would play a critical role in the successful implementation of IoT at CSD. The huge number of devices working together might have their own separate protocols and set of operating parameters. However, their integration would be of utmost importance. For instance, if the smart shelves could not integrate with digital price tags, then the perceived benefits and cost savings could not be achieved. It is pertinent to highlight that all these hardware devices are sending their real-time data to the back-end physical computer servers. The computational powers and accuracy of these servers would augment the IoT applications. CSD's managing director (personal communication, November 8, 2021) highlighted that CSD has advanced servers with high capacity to deal with IoT applications. Therefore, CSD would have to invest in other devices mentioned earlier to enable IoT applications at the Rawalpindi store.

3. Architecture

The architecture of the IoT applications at CSD would define the overall process of capturing, routing, processing, and analyzing real-time data. The functions of each physical device would be defined so that they capture the relevant data and route the same to the CSD servers and software applications. These software packages with embedded machine learning capabilities would suggest an informed decision to management. Accordingly, if CSD adopts a comprehensive setup integrating the previously discussed IoT applications, then it would be necessary to implement a sophisticated architecture for retail operations at CSD.

CSD's architecture for IoT applications would play a pivotal role in capturing relevant benefits. If there are flaws in the architecture, then CSD's significant investment in IoT technologies would either be in vain or yield a negative outcome. Moreover, the architecture would also act as a steppingstone to implement IoT. The architecture will define the extent of automation and manual work required at CSD's store, warehouse, and DC. The architecture would elaborate the connection between each device at the store to share data and subsequently route it to other devices. The role of each device in an IoT setup would be defined by the output needed from such device. The combined output of each device would be based on the overall requirements of CSD's management. Therefore, the development of an IoT architecture would be heavily based on CSD's management input. Based on that input, the IT professionals would then design the IoT architecture to meet the potential needs of management and implement the same depending upon the investment and resources allocated by the management.

THIS PAGE INTENTIONALLY LEFT BLANK

V. CONCLUSION AND RECOMMENDATIONS

Innovation has disrupted many industries. It has changed the entire business model of many organizations (Vel et al., 2010), but such change is often necessary. Innovation is typically driven by the need to enhance the customer experience (Yaqiong et al., 2018). In the wake of enhancing customer experience, organizations are changing their business models to keep pace with changing trends (Siqueira et al., 2021). Change is also transforming the retail sector, especially in the Western world (Wankhede et al., 2018). By contrast, the pace of innovation fueled by technology is slow in developing nations like Pakistan (Ali & Xie, 2021). In the Pakistani market, the traditional convenience store on the corner of every street is still common. The small scale of retail operations at these individual corner shops in Pakistan cannot accommodate technological innovation (Irfan et al., 2019). On the other hand, large superstore chains in Pakistan have started adopting new technologies to enhance customer experience (Rizvi et al., 2019). The new technologies are usually limited to digital payment processing, barcoding, and sharing of POS data with customers to better forecast demand (Ali & Xie, 2021). These large retailers have yet to tap the huge potential benefits of other new technologies, particularly IoT applications, that can deliver early adopters a competitive advantage. This study was carried out to highlight the feasibility of implementing IoT applications in CSD, one of the largest discount superstore chains of Pakistan with more than 100 stores. The study was limited to one of CSD's stores, which is located in Rawalpindi. The researchers analyzed the retailer's existing business model based on discussions with CSD's management, customers, and suppliers. Subsequently, researchers carried out detailed research on IoT applications that can be adopted by CSD to innovate its business processes and gain a competitive advantage.

CSD's existing business model follows the traditional superstore model wherein the majority of retail operations are carried out manually. The role of IT is limited to the processing of customer payments and the capture of associated POS data which is used to forecast future demand. CSD's management claims to provide an excellent customer service experience with the existing retail model. Furthermore, CSD's management

believes that the model is quite successful as is the retailer has been highly profitable. The model's success, though, is primarily based on the unique physical location of the CSD store (i.e., within military garrisons where CSD's target customer base resides). The ease of access to the CSD superstore acts as a competitive advantage as no other superstores are located within military garrisons. Furthermore, CSD's superstore can offer its customers items at discounts that traditional small grocery stores in the military garrisons cannot afford; therefore, customers remain loyal to CSD. But CSD has large competitors also, and their innovative retail offerings have the potential to affect the loyalty of CSD's customers. These customers are unlikely to remain loyal if CSD continues its traditional retailing practices that place little emphasis on customer experience. Therefore, in a changing environment that is growing more competitive, CSD needs to place more emphasis on enhancing customer experience in addition to offering discounted prices. In this regard, CSD's existing business model needs to undergo a change.

CSD can innovate its business model through the adoption of IoT technologies. This study has presented a description of various IoT applications along with their relevant implementation strategies. CSD's management could either adopt all the relevant IoT applications described through a single holistic IoT setup, or it could adopt only a few, based on CSD's most pressing needs and available resources. Either way, the adoption of all or a few IoT applications at the CSD store located at Rawalpindi will transform CSD's operations. Such a transformation can include optimization of store layout, in-store mapping on a mobile application, automated checkout, smart shelves, highly personalized promotions for customers, digital price tagging, smart CRM to communicate with customers, a robotics-based warehouse, and data-driven transportation routes for the delivery of online orders. This innovative retail model would generate big data and the subsequent utilization of AI tools would help CSD to make well-informed management decisions based on real-time data. Presently, the data being collected is limited and does not offer possibilities to adopt highly individualized promotions for its customers; therefore, promotional marketing campaigns are not very effective in yielding the desired management outcome. With IoT-based applications, the customer experience will be

tremendously enhanced, and CSD can attract an entirely new segment of online customers through a new, innovative business model.

The initial investment for developing and implementing an IoT-based business model at CSD would be high. However, in the long term, the new setup would significantly reduce costs spent on labor-intensive operations. The IoT-based business model also promises better inventory management practices. The waste of carrying excessive stock in the existing model would be eliminated through AI-based forecasting and real-time sharing of information. Similarly, the innovative business model would likely boost sales and reduce costs at CSD in multiple domains.

The new business model raises some challenges as well. Since the IoT-based applications would be based on personal data collected from customers, ensuring the security of such data to protect the privacy of customers would require additional cyber security operations. CSD would have to maintain the IT infrastructure associated with IoT-based applications, and the integration of various IoT applications would require detailed planning and development efforts. Consequently, the maintenance of such infrastructure would require relevant expertise and resources. Therefore, implementation would require a long-term commitment from CSD's employees and management to make the innovation successful. Otherwise, if the issues related to IoT implementation are not considered with strategic importance, the innovation in retail practices would not yield the expected results.

A. RECOMMENDATIONS FOR MANAGEMENT TO ADDRESS POTENTIAL IMPLEMENTATION CHALLENGES

The study has presented an overall analysis of IoT applications that can be adopted by CSD management to innovate its retail practices. Each IoT application can either be implemented as a standalone application, or it can be implemented by integration with other IoT applications. The integration of these applications can be challenging because their technical protocols and parameters may differ. Therefore, the implementation of the IoT-based setup would require assessing the technical feasibility of implementing each IoT application discussed in this study. In this regard, it is recommended that CSD's

management adopt the following roadmap to implement IoT-based applications seamlessly and reap potential benefits:

1. CSD may set targets for the potential cost savings and enhanced customer experience expected from adopting IoT applications at the Rawalpindi store only.
2. CSD may identify the potential IoT applications that can help to attain the set targets.
3. CSD may then direct IT experts and professionals to carry out a detailed technical study on each IoT application. The output of the study would be a detailed report on the technical feasibility of integration and implementation, and the estimated cost to develop and maintain IoT applications' infrastructure.
4. CSD may initiate a financial analysis of acquisition and implementation costs if the technical report favors implementation. If the resources are adequate to support the integrated implementation of all IoT applications discussed in this study, then CSD management may proceed further. Otherwise, fewer IoT applications may be considered for implementation.
5. CSD may carry out a cost-benefit analysis of IoT framework implementation. If benefits will exceed costs in the long run, then management may proceed further. Otherwise, management may halt its attempt to innovate its retail operations.
6. CSD can simulate all retail operations in an IoT environment through software packages, as a risk-reduction measure, if management can afford simulation costs. Otherwise, CSD can implement pilot IoT applications at its Rawalpindi store.
7. CSD may then observe and address potential issues arising from the implementation of the IoT applications pilot project. The pilot project may continue to be tested until the robustness of the system is ensured.

8. CSD may then implement a complete, fully integrated IoT setup at the Rawalpindi store and observe its issues and potential benefits. If the benefits seem promising and the issues can be resolved satisfactorily, then it would be a game-changer for CSD.
9. CSD may then implement its IoT setup at its other outlets where the technological applications can be supported, as CSD does operate in remote areas where such applications would not work due to the unavailability of the Internet.
10. CSD may continuously pursue testing and adopting new technologies that can provide additional benefits, cost savings, and enhanced customer experience.

B. RECOMMENDATIONS FOR FURTHER RESEARCH

This study was conducted to identify and describe IoT applications that can be adopted in the retail setup of a particular discount store chain in Pakistan (i.e., CSD). Accordingly, the following recommendations for future research merit consideration:

1. The study can act as a steppingstone for other researchers to carry out quantitative analysis of IoT applications in terms of financial considerations for CSD.
2. The scope of this research was limited to one CSD store in Rawalpindi. Future researchers may carry out studies on the feasibility of adopting IoT-based applications at all CSD stores.
3. The scope of this study was limited to the retail operations of CSD. Future researchers can take the lead from this research and carry out studies on the feasibility of adopting IoT-based applications for other areas of CSD's organization, for instance, Human Resources Management, Financial Management, Marketing Management, etc.

4. The findings of the research can be utilized by other large retailers in Pakistan, and future researchers can carry out studies to assess the feasibility of innovative retail operations at other large retailers.
5. The study was limited to the adoption of IoT-based applications at a retail grocery setup. Future research can be carried out to study IoT-based applications in other retail domains like clothing, electronic items, furniture, and automotive products.

LIST OF REFERENCES

- Abbas, A., Siddiqui, I. F., & Lee, S. U.-J. (2017). Contextual variability management of IoT application with XML-based feature modelling. *Journal of Theoretical and Applied Information Technology*, 95(6). 1300–1308. <https://repository.hanyang.ac.kr/handle/20.500.11754/128453>
- Agarwal, A., & Unhelkar, B. (2018). Internet of Things. In B. Warf (Ed.), *The SAGE encyclopedia of the Internet* (Vol. 1, pp. 540–542). SAGE Publications. <https://doi.org/10.4135/9781473960367>
- Ailawadi, K. L., & Keller, K. L. (2004). Understanding retail branding: Conceptual insights and research priorities. *Journal of Retailing*, 80(4), 331–342. <https://doi.org/10.1016/j.jretai.2004.10.008>
- Aldowah, H., Ul Rehman, S., & Umar, I. (2021). Trust in IoT systems: A vision on the current issues, challenges, and recommended solutions. In F. Saeed, T. Al-Hadhrani, F. Mohammed, & E. Mohammed (Eds.), *Advances on Smart and Soft Computing* (pp. 329–339). Springer. https://doi.org/10.1007/978-981-15-6048-4_29
- Alelaiwi, A., Alghamdi, A., Shorfuzzaman, M., Rawashdeh, M., Hossain, M. S., & Muhammad, G. (2015). Enhanced engineering education using smart class environment. *Computers in Human Behavior*, 51, 852–856. <https://doi.org/10.1016/j.chb.2014.11.061>
- Al-Fuqaha, A., Guizani, M., Mohammadi, M., Aledhari, M., & Ayyash, M. (2015). Internet of Things: A survey on enabling technologies, protocols, and applications. *IEEE Communications Surveys Tutorials*, 17(4), 2347–2376. <https://doi.org/10.1109/COMST.2015.2444095>
- Ali, K. (2020, July 20). COVID-19 and innovation in retail. *Pakistan's Growth Story*. <https://devpakistanblog.com/2020/07/20/covid-19-and-innovation-in-retail/>
- Ali, S., & Xie, Y. (2021). The impact of Industry 4.0 on organizational performance: The case of Pakistan's retail industry. *European Journal of Management Studies*, 26(2/3), 63–86. <https://doi.org/10.1108/EJMS-01-2021-0009>
- Alibaba acquires Daraz in estimated \$200 million deal. (2018, May 9). *The News*. <https://www.thenews.com.pk/print/314282-alibaba-acquires-daraz-in-estimated-200-million-deal>
- Allmendinger, R. W., Siron, C. R., & Scott, C. P. (2017). Structural data collection with mobile devices: Accuracy, redundancy, and best practices. *Journal of Structural Geology*, 102, 98–112. <https://doi.org/10.1016/j.jsg.2017.07.011>

- Al-Qaseemi, S. A., Almulhim, H. A., Almulhim, M. F., & Chaudhry, S. R. (2016). IoT architecture challenges and issues: Lack of standardization. *2016 Future Technologies Conference (FTC)*, 731–738.
- Altarturi, H. H., Ng, K.-Y., Ninggal, M. I. H., Nazri, A. S. A., & Ghani, A. A. A. (2017). A requirement engineering model for big data software. *2017 IEEE Conference on Big Data and Analytics (ICBDA)*, 111–117. <https://doi.org/10.1109/ICBDAA.2017.8284116>
- Arshad, Z. (2020, July 25). An insight into retail sector of Pakistan. *The Frontier Post*. <https://thefrontierpost.com/an-insight-into-retail-sector-of-pakistan/>
- Bayani, M., Segura, A., Alvarado, M., & Loaiza, M. (2018). IoT-based library automation and monitoring system: Developing an implementation framework of implementation. *E-Ciencias de La Información*, 8(1), 83–100. <https://dx.doi.org/10.15517/eci.v8i1.30010>
- Bennett, D. (2017, May 5). *Adopting technology for tomorrow*. CStore Decisions. <https://cstoredecisions.com/2017/05/05/adopting-technology-tomorrow/>
- Bernritter, S. F., Ketelaar, P. E., & Sotgiu, F. (2021). Behaviorally targeted location-based mobile marketing. *Journal of the Academy of Marketing Science*, 49(4), 677–702. <https://doi.org/10.1007/s11747-021-00784-0>
- BinDhim, N. F., Hawkey, A., & Trevena, L. (2015). A systematic review of quality assessment methods for smartphone health apps. *Telemedicine and E-Health*, 21(2), 97–104. <https://doi.org/10.1089/tmj.2014.0088>
- Bok, B. G. J. (2016). *Innovating the retail industry: An IoT approach* [Bachelor's thesis, University of Twente]. <http://essay.utwente.nl/69982/>
- Borkowski, S., Sandrick, C., Wagila, K., Goller, C., Ye, C., & Zhao, L. (2016). MagicBands in the Magic Kingdom: Customer-centric information technology implementation at Disney. *Journal of the International Academy for Case Studies*, 22(3), 143.
- Brous, P., Janssen, M., & Herder, P. (2020). The dual effects of the Internet of Things (IoT): A systematic review of the benefits and risks of IoT adoption by organizations. *International Journal of Information Management*, 51, 101952. <https://doi.org/10.1016/j.ijinfomgt.2019.05.008>
- Burt, S. (2000). The strategic role of retail brands in British grocery retailing. *European Journal of Marketing*, 34(8), 875–890. <https://doi.org/10.1108/03090560010331351>

- Cao, L. (2021). Artificial intelligence in retail: Applications and value creation logics. *International Journal of Retail & Distribution Management*, 49(7), 958–976. <https://doi.org/10.1108/IJRDM-09-2020-0350>
- Car, T., Stifanich, L. P., & Šimunić, M. (2019). Internet of Things (IoT) in tourism and hospitality: Opportunities and challenges. *Tourism in South East Europe*, 5, 163–175. <https://doi.org/10.20867/tosee.05.42>
- Caro, F., & Sadr, R. (2019). The Internet of Things (IoT) in retail: Bridging supply and demand. *Business Horizons*, 62(1), 47–54. <https://doi.org/10.1016/j.bushor.2018.08.002>
- Chen, C. (2021). The study on the store image of hypermarkets: An empirical study of Carrefour, Fe-Amart, and Costco in Taiwan. *International Journal of Asian Business and Information Management (IJABIM)*, 12(3), 205–221. <https://doi.org/10.4018/IJABIM.20210701.oa13>
- Chen, Y.-T., Sun, E. W., Chang, M.-F., & Lin, Y.-B. (2021). Pragmatic real-time logistics management with traffic IoT infrastructure: Big data predictive analytics of freight travel time for Logistics 4.0. *International Journal of Production Economics*, 238, 108157. <https://doi.org/10.1016/j.ijpe.2021.108157>
- Choudhary, G., & Jain, A. K. (2016). Internet of things: A survey on architecture, technologies, protocols and challenges. *2016 International Conference on Recent Advances and Innovations in Engineering (ICRAIE)*, 1–8. <https://doi.org/10.1109/ICRAIE.2016.7939537>
- Coronado-Hernández, J. R., Macías-Jiménez, M. A., Chica-Llamas, J. D., & Zapata-Márquez, J. I. (2021). Assessment of organizational policies in a retail store based on a simulation model. In K. Saeed & J. Dvorský (Eds.), *Computer Information Systems and Industrial Management* (pp. 245–258). Springer International Publishing. https://doi.org/10.1007/978-3-030-84340-3_20
- CSD The Caring Store. (n.d.). *About us—CSD The caring store*. Retrieved October 11, 2021, from <https://www.csd.gov.pk/about-us/>
- Das, S. (2019). The early bird catches the worm—First mover advantage through IoT adoption for Indian public sector retail oil outlets. *Journal of Global Information Technology Management*, 22(4), 280–308. <https://doi.org/10.1080/1097198X.2019.1679588>
- de Carvalho Silva, J., Rodrigues, J. J. P. C., Alberti, A. M., Solic, P., & Aquino, A. L. L. (2017). LoRaWAN—A low power WAN protocol for Internet of Things: A review and opportunities. *2017 2nd International Multidisciplinary Conference on Computer and Energy Science (SpliTech)*, 1–6.

- de Vass, T., Shee, H., & Miah, S. J. (2021). IoT in supply chain management: A narrative on retail sector sustainability. *International Journal of Logistics Research and Applications*, 24(6), 605–624. <https://doi.org/10.1080/13675567.2020.1787970>
- Dennis, S. (2020, July 20). *Why does it take a crisis for retailers to get innovative?* Retail Wire. <https://retailwire.com/discussion/why-does-it-take-a-crisis-for-retailers-to-get-innovative/>
- Dentamaro, V., Impedovo, D., Pirlo, G., Abbattista, G., Gattulli, V., Buscicchio, C. A., & Fiore, C. M. (2021). Non-invasive personalized in-store location-based marketing: A practical use case. In B. Christiansen, & T. Škrinjarić (Ed.), *Handbook of Research on Applied AI for International Business and Marketing Applications* (pp. 365–390). IGI Global. <https://doi.org/10.4018/978-1-7998-5077-9.ch018>
- Derakhshan, R., Orłowska, M. E., & Li, X. (2007). RFID data management: Challenges and opportunities. *2007 IEEE International Conference on RFID*, 175–182. <https://doi.org/10.1109/RFID.2007.346166>
- Ding, J., Nemati, M., Ranaweera, C., & Choi, J. (2020). IoT connectivity technologies and applications: A survey. *IEEE Access*, 8, 67646–67673. <https://doi.org/10.1109/ACCESS.2020.2985932>
- Dlamini, N. N., & Johnston, K. (2016). The use, benefits and challenges of using the Internet of Things (IoT) in retail businesses: A literature review. *2016 International Conference on Advances in Computing and Communication Engineering (ICACCE)*, 430–436. <https://doi.org/10.1109/ICACCE.2016.8073787>
- Dörndorfer, J., & Seel, C. (2016). The impact of mobile devices and applications on business process management. *Prozesse, Technologie, Anwendungen, Systeme und Management*, 10–19.
- Fiorito, S. S., Gable, M., & Conseur, A. (2010). Technology: Advancing retail buyer performance in the twenty-first century. *International Journal of Retail & Distribution Management*, 38(11/12), 879–893. <https://doi.org/10.1108/09590551011085966>
- Garrido-Moreno, A., Lockett, N., & Garcia-Morales, V. (2015). Exploring the role of knowledge management practices in fostering customer relationship management as a catalyst of marketing innovation. *Baltic Journal of Management*, 10(4), 393–412. <https://doi.org/10.1108/BJM-10-2014-0166>
- Ghani, J. A. (2005). Consolidation in Pakistan's retail sector. *Asian Journal of Management Cases*, 2(2), 137–161.
- Gregory, J. (2015). The Internet of Things: Revolutionizing the retail industry. *Accenture Strategy*, 1–8.

- Grewal, D., Motyka, S., & Levy, M. (2018). The evolution and future of retailing and retailing education. *Journal of Marketing Education*, 40(1), 85–93. <https://doi.org/10.1177/0273475318755838>
- Grewal, D., Noble, S. M., Roggeveen, A. L., & Nordfalt, J. (2020). The future of in-store technology. *Journal of the Academy of Marketing Science*, 48(1), 96–113. <https://doi.org/10.1007/s11747-019-00697-z>
- Guha, A., Grewal, D., Kopalle, P. K., Haenlein, M., Schneider, M. J., Jung, H., Moustafa, R., Hegde, D. R., & Hawkins, G. (2021). How artificial intelligence will affect the future of retailing. *Journal of Retailing*, 97(1), 28–41. <https://doi.org/10.1016/j.jretai.2021.01.005>
- Heidel, A., & Hagist, C. (2020). Potential benefits and risks resulting from the introduction of health apps and wearables into the German Statutory Health Care System: Scoping review. *JMIR MHealth and UHealth*, 8(9), e16444. <https://doi.org/10.2196/16444>
- Here's how the Internet of Things will explode by 2020. (2016, April 28). [Research Firm]. Business Insider. <https://www.businessinsider.com/iot-ecosystem-internet-of-things-forecasts-and-business-opportunities-2016-4-28>
- Hermes, A., & Riedl, R. (2021). Dimensions of retail customer experience and its outcomes: A literature review and directions for future research. In F. F.-H. Nah & K. Siau (Eds.), *HCI in Business, Government and Organizations* (pp. 71–89). Springer International Publishing. https://doi.org/10.1007/978-3-030-77750-0_5
- Hicks, D., Mannix, K., Bowles, H. M., & Gao, B. J. (2013). SmartMart: IoT-based in-store mapping for mobile devices. *9th IEEE International Conference on Collaborative Computing: Networking, Applications and Worksharing*, 616–621. <https://doi.org/10.4108/icst.collaboratecom.2013.254116>
- Holland, C., Levis, J., Nugehalli, R., Santilli, B., & Winters, J. (2017). UPS optimizes delivery routes. *INFORMS Journal on Applied Analytics*, 47(1), 8–23. <https://doi.org/10.1287/inte.2016.0875>
- Huo, J. (2021). Supply chain coordination. In J. Huo (Ed.), *Advances in Theory and Practice in Store Brand Operations* (pp. 211–253). Springer. https://doi.org/10.1007/978-981-15-9877-7_5
- Hustad, E., & Olsen, D. H. (2013). Critical issues across the ERP life cycle in small-and-medium-sized enterprises: Experiences from a multiple case study. *Procedia Technology*, 9, 179–188. <https://doi.org/10.1016/j.protcy.2013.12.020>

- Hwang, G., Lee, J., Park, J., & Chang, T.-W. (2017). Developing performance measurement system for Internet of Things and smart factory environment. *International Journal of Production Research*, 55(9), 2590–2602. <https://doi.org/10.1080/00207543.2016.1245883>
- Imran, M., ul Hameed, W., & ul Haque, A. (2018). Influence of industry 4.0 on the production and service sectors in Pakistan: Evidence from textile and logistics industries. *Social Sciences*, 7(12), 246. <https://doi.org/10.3390/socsci7120246>
- Insignares, A. (2021, February 25). *Augmented reality in retail: How to make your store stand out*. Koombea. <https://www.koombea.com/blog/augmented-reality-in-retail-how-to-make-your-store-stand-out/>
- Iqbal, M. S., Rahim, Z. A., & Hussain, S. A. (2020). Industry 4.0 revolution and challenges in developing countries: A case study on Pakistan. *Journal of Advanced Research in Business and Management Studies*, 21(1), 40–52.
- Iqbal, W., Abbas, H., Daneshmand, M., Rauf, B., & Bangash, Y. A. (2020). An in-depth analysis of IoT security requirements, challenges, and their countermeasures via software-defined security. *IEEE Internet of Things Journal*, 7(10), 10250–10276. <https://doi.org/10.1109/JIOT.2020.2997651>
- Irfan, W., Siddiqui, D. A., & Ahmed, W. (2019). Creating and retaining customers: Perspective from Pakistani small and medium retail stores. *International Journal of Retail & Distribution Management*, 47(4), 350–367. <https://doi.org/10.1108/IJRDM-03-2018-0045>
- Ishfaq, R., Defee, C. C., Gibson, B. J., & Raja, U. (2016). Realignment of the physical distribution process in omni-channel fulfillment. *International Journal of Physical Distribution & Logistics Management*, 46(6/7), 543–561. <https://doi.org/10.1108/IJPDLM-02-2015-0032>
- Jayamini, C., Sandamini, A., Pannala, T., Kumarasinghe, P., Perera, D., & Karunanayaka, K. (2021). The use of augmented reality to deliver enhanced user experiences in fashion industry. *Lecture Notes in Computer Science*, 12936. <https://usehci.org/mar2021/proceedings/>
- Jernigan, S., Kiron, D., & Ransbotham, S. (2016). Data sharing and analytics are driving success with IoT. *MIT Sloan Management Review*, 58(1), 0–0. <https://www.proquest.com/docview/1832206447/abstract/18C6490D8B3F4CB5PQ/1>
- Kalange, S. H., Kadam, D. A., Mokal, A. B., & Patil, A. A. (2017). Smart retailing using IOT. *International Research Journal of Engineering and Technology (IRJET)*, 4(11), 263–268.

- Kasiri, N. (2021). RFID applications in retail. In *Electromagnetic Wave Propagation for Industry and Biomedical Applications*. IntechOpen. <https://doi.org/10.5772/intechopen.95787>
- Khanna, A., & Tomar, R. (2016). IoT based interactive shopping ecosystem. *2016 2nd International Conference on Next Generation Computing Technologies (NGCT)*, 40–45. <https://doi.org/10.1109/NGCT.2016.7877387>
- Kramp, T., van Kranenburg, R., & Lange, S. (2013). Introduction to the Internet of Things. In *Enabling Things to Talk* (pp. 1–10). Springer.
- Krishnan, P. (2018). Design of collision detection system for smart car using Li-Fi and ultrasonic sensor. *IEEE Transactions on Vehicular Technology*, 67(12), 11420–11426. <https://doi.org/10.1109/TVT.2018.2870995>
- Kuzminykh, I., Ghita, B., & Such, J. M. (2020). The challenges with Internet of Things for business. *ArXiv:2012.03589 [Cs]*. <http://arxiv.org/abs/2012.03589>
- Lawrence, C. (2016, May 17). *How IoT is changing the fashion retail experience*. ReadWrite. <https://readwrite.com/how-iot-is-changing-the-fashion-retail-experience-vr4/>
- Li, J., & Liu, H. (2016). Design optimization of Amazon robotics. *Automation, Control and Intelligent Systems*, 4(2), 48–52.
- Lin, J., Yu, W., Zhang, N., Yang, X., Zhang, H., & Zhao, W. (2017). A survey on Internet of Things: Architecture, enabling technologies, security and privacy, and applications. *IEEE Internet of Things Journal*, 4(5), 1125–1142. <https://doi.org/10.1109/JIOT.2017.2683200>
- Ling, L., Yelland, N., Hatzigianni, M., & Dickson-Deane, C. (2022). The use of Internet of Things devices in early childhood education: A systematic review. *Education and Information Technologies*. <https://doi.org/10.1007/s10639-021-10872-x>
- Liu, L., Zhou, B., Zou, Z., Yeh, S.-C., & Zheng, L. (2018). A smart unstaffed retail shop based on artificial intelligence and IoT. *2018 IEEE 23rd International Workshop on Computer Aided Modeling and Design of Communication Links and Networks (CAMAD)*, 1–4. <https://doi.org/10.1109/CAMAD.2018.8514988>
- Live View GPS. (2015, May 26). Supermarket uses GPS tracking devices on shopping carts. *Live View GPS Tracking Blog*. <https://www.liveviewgps.com/blog/supermarket-gps-tracking-devices-shopping-carts/>
- Lo, F.-Y., & Campos, N. (2018). Blending Internet-of-Things (IoT) solutions into relationship marketing strategies. *Technological Forecasting and Social Change*, 137, 10–18. <https://doi.org/10.1016/j.techfore.2018.09.029>

- Longe, O. M., Ouahada, K., Rimer, S., Zhu, H., & Ferreira, H. C. (2015). Effective energy consumption scheduling in smart homes. *AFRICON 2015*, 1–5. <https://doi.org/10.1109/AFRCON.2015.7331917>
- Madhani, P. M. (2021). Retail workforce sizing strategy for enhancing service delivery and store performance. *International Journal of Business Strategy and Automation (IJBSA)*, 2(3), 1–19. <https://doi.org/10.4018/IJBSA.20210701.oa1>
- Malliaris, M. (2018). Internet of Things (IoT). In R. Kolb (Ed.), *The SAGE Encyclopedia of Business Ethics and Society* (Vol. 1, pp. 1924–1926). SAGE Publications. <https://doi.org/10.4135/9781483381503>
- Manyika, J., Chui, M., Bisson, P., Woetzel, J., Dobbs, R., Bughin, J., & Aharon, D. (2015). *The Internet of Things: Mapping the value beyond the hype* (Vol. 24). McKinsey Global Institute.
- Maqsood, M., & Haseebuddin, M. (2015). Cloud computing for retailing industry: An overview. *International Journal of Computer Trends and Technology*, 19(1), 51–56. <https://doi.org/10.14445/22312803/IJCTT-V19P110>
- McLean, G., & Osei-Frimpong, K. (2019). Hey Alexa ... examine the variables influencing the use of artificial intelligent in-home voice assistants. *Computers in Human Behavior*, 99, 28–37. <https://doi.org/10.1016/j.chb.2019.05.009>
- Mendiola, M. F., Kalnicki, M., & Lindenauer, S. (2015). Valuable features in mobile health apps for patients and consumers: Content analysis of apps and user ratings. *JMIR MHealth and UHealth*, 3(2), e4283. <https://doi.org/10.2196/mhealth.4283>
- Mercan, S., Cain, L., Akkaya, K., Cebe, M., Uluagac, S., Alonso, M., & Cobanoglu, C. (2020). Improving the service industry with hyper-connectivity: IoT in hospitality. *International Journal of Contemporary Hospitality Management*, 33(1), 243–262. <https://doi.org/10.1108/IJCHM-06-2020-0621>
- Miguez, M., Marioni, M., Ortiz, M., Vogel, G., & Arnaud, A. (2019). An IoT-based electronic price-tag for food retail. *2019 26th IEEE International Conference on Electronics, Circuits and Systems (ICECS)*, 189–192. <https://doi.org/10.1109/ICECS46596.2019.8964686>
- Mishra, A., & Mohapatro, M. (2020). Real-time RFID-based item tracking using IoT amp; efficient inventory management using Machine Learning. *2020 IEEE 4th Conference on Information Communication Technology (CICT)*, 1–6. <https://doi.org/10.1109/CICT51604.2020.9312074>
- Mishra, N., & Keshri, A. K. (2021). Smart racking and retailing using IOT. In V. Nath & J. K. Mandal (Eds.), *Proceedings of the Fourth International Conference on Microelectronics, Computing and Communication Systems* (pp. 645–653). Springer. https://doi.org/10.1007/978-981-15-5546-6_54

- Mohammadian, H. D. (2019). IoT—A solution for educational management challenges. *2019 IEEE Global Engineering Education Conference (EDUCON)*, 1400–1406. <https://doi.org/10.1109/EDUCON.2019.8725213>
- Mohdhar, A., & Shaalan, K. (2021). The future of e-commerce systems: 2030 and beyond. In M. Al-Emran & K. Shaalan (Eds.), *Recent Advances in Technology Acceptance Models and Theories* (pp. 311–330). Springer International Publishing. https://doi.org/10.1007/978-3-030-64987-6_18
- Munir, S., & Stankovic, J. A. (2014). DepSys: Dependency aware integration of cyber-physical systems for smart homes. *2014 ACM/IEEE International Conference on Cyber-Physical Systems (ICCPS)*, 127–138. <https://doi.org/10.1109/ICCPS.2014.6843717>
- Nadkarni, S., Kriechbaumer, F., Rothenberger, M., & Christodoulidou, N. (2019). The path to the Hotel of Things: Internet of Things and Big Data converging in hospitality. *Journal of Hospitality and Tourism Technology*, *11*(1), 93–107. <https://doi.org/10.1108/JHTT-12-2018-0120>
- Nasser, T., & Soomro, T. (2015). Big Data challenges. *Computer Engineering & Information Technology*, *04*(03). <https://doi.org/10.4172/2324-9307.1000133>
- Newberg, M. (2020, July 23). The secret hiding inside Amazon’s new smart shopping carts. *HNGRY*. <https://medium.com/hngry/the-secret-hiding-inside-amazons-new-smart-shopping-carts-f17f5bffab78>
- Nikhashemi, S. R., Knight, H. H., Nusair, K., & Liat, C. B. (2021). Augmented reality in smart retailing: A (n) (A) Symmetric Approach to continuous intention to use retail brands’ mobile AR apps. *Journal of Retailing and Consumer Services*, *60*, 102464. <https://doi.org/10.1016/j.jretconser.2021.102464>
- Ninikrishna, T., Sarkar, S., Tengshe, R., Jha, M. K., Sharma, L., Daliya, V. K., & Routray, S. K. (2017). Software defined IoT: Issues and challenges. *2017 International Conference on Computing Methodologies and Communication (ICCMC)*, 723–726. <https://doi.org/10.1109/ICCMC.2017.8282560>
- Noto La Diega, G., & Walden, I. (2016). *Contracting for the “Internet of Things”*: *Looking into the Nest* (SSRN Scholarly Paper ID 2725913). Social Science Research Network. <https://papers.ssrn.com/abstract=2725913>
- Nunes, D. S., Zhang, P., & Silva, J. S. (2015). A survey on human-in-the-loop applications towards an Internet of all. *IEEE Communications Surveys & Tutorials*, *17*(2), 944–965.
- Nur-A-Alam, Ahsan, M., Based, M. A., Haider, J., & Rodrigues, E. M. G. (2021). Smart monitoring and controlling of appliances using LoRa based IoT System. *Designs*, *5*(1), 17. <https://doi.org/10.3390/designs5010017>

- Pakistan retail market transforming into fastest growing retail market. (2021, November 13). *Pakistan Shining*. <https://pakistanshining.com/pakistan-millennials-drive-worlds-fastest-retail-market/>
- Pantano, E., Priporas, C. V., & Dennis, C. (2018). A new approach to retailing for successful competition in the new smart scenario. *International Journal of Retail & Distribution Management*, 46(3), 264–282. <https://doi.org/10.1108/IJRDM-04-2017-0080>
- Parada, R., Melià-Seguí, J., Carreras, A., Morenza-Cinos, M., & Pous, R. (2015). Measuring user-object interactions in IoT spaces. *2015 IEEE International Conference on RFID Technology and Applications (RFID-TA)*, 52–58. <https://doi.org/10.1109/RFID-TA.2015.7379797>
- Paredes, D. (2015). Retailers need advanced analytics to compete in digitalised marketplace: Gartner. CIO (13284045), 1.
- Perilla, F. S., Villanueva, G. R., Cacanindin, N. M., & Palaoag, T. D. (2018). Fire safety and alert system using Arduino sensors with IoT integration. *Proceedings of the 2018 7th International Conference on Software and Computer Applications*, 199–203. <https://doi.org/10.1145/3185089.3185121>
- Ploder, C., Bernsteiner, R., Dilger, T., & Huber, S. (2021). Customer relationship management improvement using IoT data. *Proceedings of the 6th International Conference on Internet of Things, Big Data and Security*, 115–122. <https://doi.org/10.5220/0010378101150122>
- Pramanik, P. K. D., Pal, S., & Choudhury, P. (2018). Beyond automation: The cognitive IoT. Artificial intelligence brings sense to the Internet of Things. In A. K. Sangaiah, A. Thangavelu, & V. Meenakshi Sundaram (Eds.), *Cognitive Computing for Big Data Systems Over IoT: Frameworks, Tools and Applications* (pp. 1–37). Springer International Publishing. https://doi.org/10.1007/978-3-319-70688-7_1
- Pricer. (n.d.). *Digital price tags—Most reliable electronic shelf label system in the world*. Pricer. Retrieved January 16, 2022, from <https://www.pricer.com/products/digital-price-tags/>
- Progressive Grocer. (n.d.). *Digital transformation 101: A guide to the new retail revolution*. Progressive Grocer. Retrieved January 16, 2022, from <https://progressivegrocer.com/digital-transformation-101-aperion>
- Rehman, N., & Charpe, N. A. (2021). Assessment of checkout operator’s workload in organized retail stores of India. In M. Muzammil, A. A. Khan, & F. Hasan (Eds.), *Ergonomics for Improved Productivity* (pp. 373–381). Springer. https://doi.org/10.1007/978-981-15-9054-2_42

- Retail Space Solutions. (2020, February 28). Grocery shopping reimagined with augmented reality. *Retail Space Solutions*. <https://retailspaceolutions.com/blog/grocery-shopping-reimagined-with-augmented-reality/>
- Rizvi, M., Khan, M. A., & Zubair, D. S. S. (2019). Prospects for online grocery shopping in Pakistan. *Governance and Management Review (ISSN-2521-554X)*, 4(2), 76–91.
- Rose, K., Eldridge, S., & Chapin, L. (2015). The Internet of Things: An overview. *The Internet Society (ISOC)*, 80, 1–50.
- Sarwar, M. A., Daraghmi, Y.-A., Liu, K.-W., Chi, H.-C., İk, T.-U., & Li, Y.-L. (2020). Smart shopping carts based on mobile computing and deep learning cloud services. *2020 IEEE Wireless Communications and Networking Conference (WCNC)*, 1–6. <https://doi.org/10.1109/WCNC45663.2020.9120574>
- Sethi, P., & Sarangi, S. R. (2017). Internet of Things: Architectures, protocols, and applications. *Journal of Electrical and Computer Engineering*, 2017, e9324035. <https://doi.org/10.1155/2017/9324035>
- Shafique, M., Theocharides, T., Bouganis, C.-S., Hanif, M. A., Khalid, F., Hafiz, R., & Rehman, S. (2018). An overview of next-generation architectures for machine learning: Roadmap, opportunities and challenges in the IoT era. *2018 Design, Automation Test in Europe Conference Exhibition (DATE)*, 827–832. <https://doi.org/10.23919/DATE.2018.8342120>
- Shakhidi, K. (2020, June 18). Information is the new gold. *Forbes*. <https://www.forbes.com/sites/forbesfinancecouncil/2020/06/18/information-is-the-new-gold/>
- Shamsuzzoha, A., Ehlers, M., Addo-Tengkorang, R., & Helo, P. (2021). Tracking and tracing of global supply chain network: Case study from a Finnish company. *Proceedings of the 23rd International Conference on Enterprise Information Systems*, 118–125. <https://doi.org/10.5220/0010515401180125>
- Sharma, N., Shamkuwar, M., & Singh, I. (2019). The history, present and future with IoT. In V. E. Balas, V. K. Solanki, R. Kumar, & M. Khari (Eds.), *Internet of Things and Big Data Analytics for Smart Generation* (pp. 27–51). Springer International Publishing. https://doi.org/10.1007/978-3-030-04203-5_3
- Sharma, P., Ueno, A., & Kingshott, R. (2021). Self-service technology in supermarkets—Do frontline staff still matter? *Journal of Retailing and Consumer Services*, 59, 102356. <https://doi.org/10.1016/j.jretconser.2020.102356>
- Shinde, G. R., Dhotre, P. S., Mahalle, P. N., & Dey, N. (2020). *Internet of Things Integrated augmented reality*. Springer Nature.

- Siqueira, J. R., Peña-García, N., ter Horst, E., Molina, G., & Villamil, M. (2021). The role of brand commitment in the retail sector: The relation with open innovation. *Journal of Open Innovation: Technology, Market, and Complexity*, 7(2), 154. <https://doi.org/10.3390/joitmc7020154>
- SoluM Europe. (n.d.). *Shelf labeling 101: How do electronic shelf price tags work?* SoluM Europe. Retrieved February 19, 2022, from <https://solumesl.com/en/insights/how-do-electronic-shelf-price-tags-work>
- Song, Y., Yu, F. R., Zhou, L., Yang, X., & He, Z. (2021). Applications of the Internet of Things (IoT) in smart logistics: A comprehensive survey. *IEEE Internet of Things Journal*, 8(6), 4250–4274. <https://doi.org/10.1109/JIOT.2020.3034385>
- Stankovic, J. A. (2014). Research directions for the Internet of Things. *IEEE Internet of Things Journal*, 1(1), 3–9. <https://doi.org/10.1109/JIOT.2014.2312291>
- Stubbs, A. (2016). Intel unveils IoT platform for retailers. *Global Telecoms Business*, 1–1. <https://search.ebscohost.com/login.aspx?direct=true&db=bth&AN=112834201&site=ehost-live&scope=site>.
- Sturari, M., Liciotti, D., Pierdicca, R., Frontoni, E., Mancini, A., Contigiani, M., & Zingaretti, P. (2016). Robust and affordable retail customer profiling by vision and radio beacon sensor fusion. *Pattern Recognition Letters*, 81, 30–40. <https://doi.org/10.1016/j.patrec.2016.02.010>
- Tirmizi, F. (2010, September 26). The changing face of retail. *The Express Tribune*. <http://tribune.com.pk/story/55005/the-changing-face-of-retail>
- Tlapaná, T., & Mduba, K. (2021). Customer service and its impact on consumer buying patterns. *Modern Management Review*, 26(2), 67–78. <https://doi.org/10.7862/rz.2021.mmr.12>
- Tran-Dang, H., Krommenacker, N., Charpentier, P., & Kim, D.-S. (2020). The Internet of Things for logistics: Perspectives, application review, and challenges. *IETE Technical Review*, 1–29. <https://doi.org/10.1080/02564602.2020.1827308>
- Uckelmann, D. (2012). Performance measurement and cost benefit analysis for RFID and Internet of Things implementations in logistics. In D. Uckelmann (Ed.), *Quantifying the Value of RFID and the EPCglobal Architecture Framework in Logistics* (pp. 71–100). Springer. https://doi.org/10.1007/978-3-642-27991-1_4
- Udoh, I. S., & Kotonya, G. (2018). Developing IoT applications: Challenges and frameworks. *IET Cyber-Physical Systems: Theory & Applications*, 3(2), 65–72.

- Vargheese, R., & Dahir, H. (2014). An IoT/IoE enabled architecture framework for precision on shelf availability: Enhancing proactive shopper experience. *2014 IEEE International Conference on Big Data (Big Data)*, 21–26. <https://doi.org/10.1109/BigData.2014.7004418>
- Vel, K. P., Dayal, A., & Eastaugh, D. (2010). Retail physicality and identity change as innovation strategies: The case of better life. *Business Strategy Series*, *11*(4), 204–213. <https://doi.org/10.1108/17515631011063721>
- Verhulst, S. G., & Young, A. (2018, January 23). How the data that Internet companies collect can be used for the public good. *Harvard Business Review*. <https://hbr.org/2018/01/how-the-data-that-internet-companies-collect-can-be-used-for-the-public-good>
- Wang, D., Lo, D., Bhimani, J., & Sugiura, K. (2015). AnyControl—IoT based home appliances monitoring and controlling. *2015 IEEE 39th Annual Computer Software and Applications Conference*, *3*, 487–492. <https://doi.org/10.1109/COMPSAC.2015.259>
- Wankhede, K., Wukkadada, B., & Nadar, V. (2018). Just walk-out technology and its challenges: A case of Amazon Go. *2018 International Conference on Inventive Research in Computing Applications (ICIRCA)*, 254–257. <https://doi.org/10.1109/ICIRCA.2018.8597403>
- Yaqiong, L., Lei, T., Lee, C. K. M., & Xin, T. (2018). IoT based omnichannel logistics service in industry 4.0. *2018 IEEE International Conference on Service Operations and Logistics, and Informatics (SOLI)*, 240–243. <https://doi.org/10.1109/SOLI.2018.8476708>
- Yerpude, S., & Singhal, T. K. (2017). Internet of Things and its impact on business analytics. *Indian Journal of Science and Technology*, *10*(5), 1–6. <https://doi.org/10.17485/ijst/2017/v10i15/111794>
- Yudiansyah, A., S, D. A., Keke, Y., & Veronica, V. (2020). Can the mobile robot be a future order-picking solution?: A case study at Amazon fulfillment center. *Advances in Transportation and Logistics Research*, *3*, 800–806. <https://doi.org/10.25292/atlr.v3i0.339>
- Zamil, A. M. (2011). Customer relationship management: A strategy to sustain the organization's name and products in the customers' minds. *European Journal of Social Sciences*, *22*(3), 451–459.

THIS PAGE INTENTIONALLY LEFT BLANK

INITIAL DISTRIBUTION LIST

1. Defense Technical Information Center
Ft. Belvoir, Virginia
2. Dudley Knox Library
Naval Postgraduate School
Monterey, California