

# Designing Next Generation Polymer- Based Surfactants for Fire Suppression (WP-1559)

Dr. Timothy E. Long (Virginia Tech)

Dr. Brian Y. Lattimer (Jensen Hughes)



COLLEGE OF SCIENCE  
**CHEMISTRY**  
VIRGINIA TECH.



JENSEN HUGHES  
Advancing the Science of Safety



Arizona State  
University

## Objectives

1. Design a polymeric surfactant platform of **all-aromatic, polyimides**
2. Demonstrate **crosslinkable** all-aromatic **aqueous** polyimide foams
3. Explore versatile pendant **sulfonates** to further tailor fire performance



*Foamed formulation*

Benjamin J. Stovall (Virginia Tech)

Clay B. Arrington (Virginia Tech)

Joshua B. Dinaburg (Jensen Hughes)

# REPORT DOCUMENTATION PAGE

*Form Approved*  
OMB No. 0704-0188

The public reporting burden for this collection of information is estimated to average 1 hour per response, including the time for reviewing instructions, searching existing data sources, gathering and maintaining the data needed, and completing and reviewing the collection of information. Send comments regarding this burden estimate or any other aspect of this collection of information, including suggestions for reducing the burden, to Department of Defense, Washington Headquarters Services, Directorate for Information Operations and Reports (0704-0188), 1215 Jefferson Davis Highway, Suite 1204, Arlington, VA 22202-4302. Respondents should be aware that notwithstanding any other provision of law, no person shall be subject to any penalty for failing to comply with a collection of information if it does not display a currently valid OMB control number.  
**PLEASE DO NOT RETURN YOUR FORM TO THE ABOVE ADDRESS.**

<b>1. REPORT DATE (DD-MM-YYYY)</b> 11/12/2020		<b>2. REPORT TYPE</b> SERDP Project Outbrief		<b>3. DATES COVERED (From - To)</b> 1/3/2019 - 1/3/2021	
<b>4. TITLE AND SUBTITLE</b> Designing Next Generation Polymer Based Surfactants for Fire Suppression				<b>5a. CONTRACT NUMBER</b> 19-P-0001	
				<b>5b. GRANT NUMBER</b>	
				<b>5c. PROGRAM ELEMENT NUMBER</b>	
<b>6. AUTHOR(S)</b> Dr. Timothy E. Long, Benjamin J. Stovall, Clay B. Arrington Virginia Polytechnic Institute and State University  Joshua B. Dinaburg, Dr. Brian Y. Lattimer Jensen Hughes				<b>5d. PROJECT NUMBER</b> WP18-1559	
				<b>5e. TASK NUMBER</b>	
				<b>5f. WORK UNIT NUMBER</b>	
<b>7. PERFORMING ORGANIZATION NAME(S) AND ADDRESS(ES)</b> Virginia Polytechnic Institute and State University 1040 Drillfield Drive Davidson Hall, Rm 480 (0212) Blacksburg, VA 24061				<b>8. PERFORMING ORGANIZATION REPORT NUMBER</b> WP18-1559	
<b>9. SPONSORING/MONITORING AGENCY NAME(S) AND ADDRESS(ES)</b> Strategic Environmental Research and Development Program 4800 Mark Center Drive, Suite 16F16 Alexandria, VA 22350-3605				<b>10. SPONSOR/MONITOR'S ACRONYM(S)</b> SERDP	
				<b>11. SPONSOR/MONITOR'S REPORT NUMBER(S)</b> WP18-1559	
<b>12. DISTRIBUTION/AVAILABILITY STATEMENT</b> DISTRIBUTION STATEMENT A. Approved for public release: distribution unlimited.					
<b>13. SUPPLEMENTARY NOTES</b>					
<b>14. ABSTRACT</b> The technical objectives of this project are listed below: <ul style="list-style-type: none"> <li>• 1. Design a polymeric surfactant platform of all aromatic, polyimides</li> <li>2. Demonstrate crosslinkable all aromatic aqueous polyimide foam</li> <li>3. Explore versatile pendant sulfonates to further tailor fire performance</li> </ul>					
<b>15. SUBJECT TERMS</b> Polymer Based Surfactants, Fire Suppression, AFFF					
<b>16. SECURITY CLASSIFICATION OF:</b>			<b>17. LIMITATION OF ABSTRACT</b>  UNCLASS	<b>18. NUMBER OF PAGES</b>  26	<b>19a. NAME OF RESPONSIBLE PERSON</b> Timothy Long
<b>a. REPORT</b>  UNCLASS	<b>b. ABSTRACT</b>  UNCLASS	<b>c. THIS PAGE</b>  UNCLASS			<b>19b. TELEPHONE NUMBER (Include area code)</b> 540-231-2480





# Innovative polymer “solutions” to combat use of fluorosurfactants

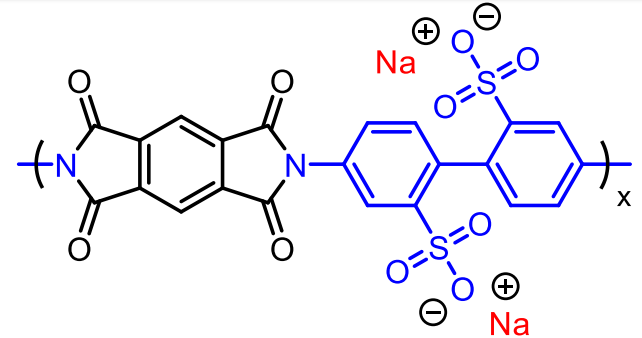
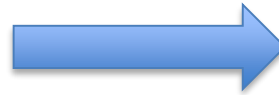
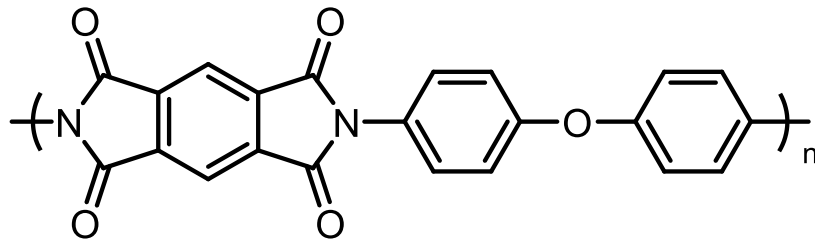

## Aromatic polyimides display advantageous properties:

- Operating temp. up to 450 °C
- Elastic modulus 2+ GPa
- **High UL-94 flammability rating**
- Thermal, electrical, radiation resistance
- **Insoluble/non-dispersible in water**

## Sulfonated fully aromatic PI:

- ✓ **Water soluble/dispersible**
- ✓ **High char yields**
- ✓ **Surfactant miscibility**
- ✓ **Ionic/ compositional modularity**

Next generation fluorine-free foams based on a novel polymer technology, which meet fire qualification requirements, limit environmental impact, and are compatible with existing AFFF equipment

# Foam behavior can be investigated with regard to a modular molecular design

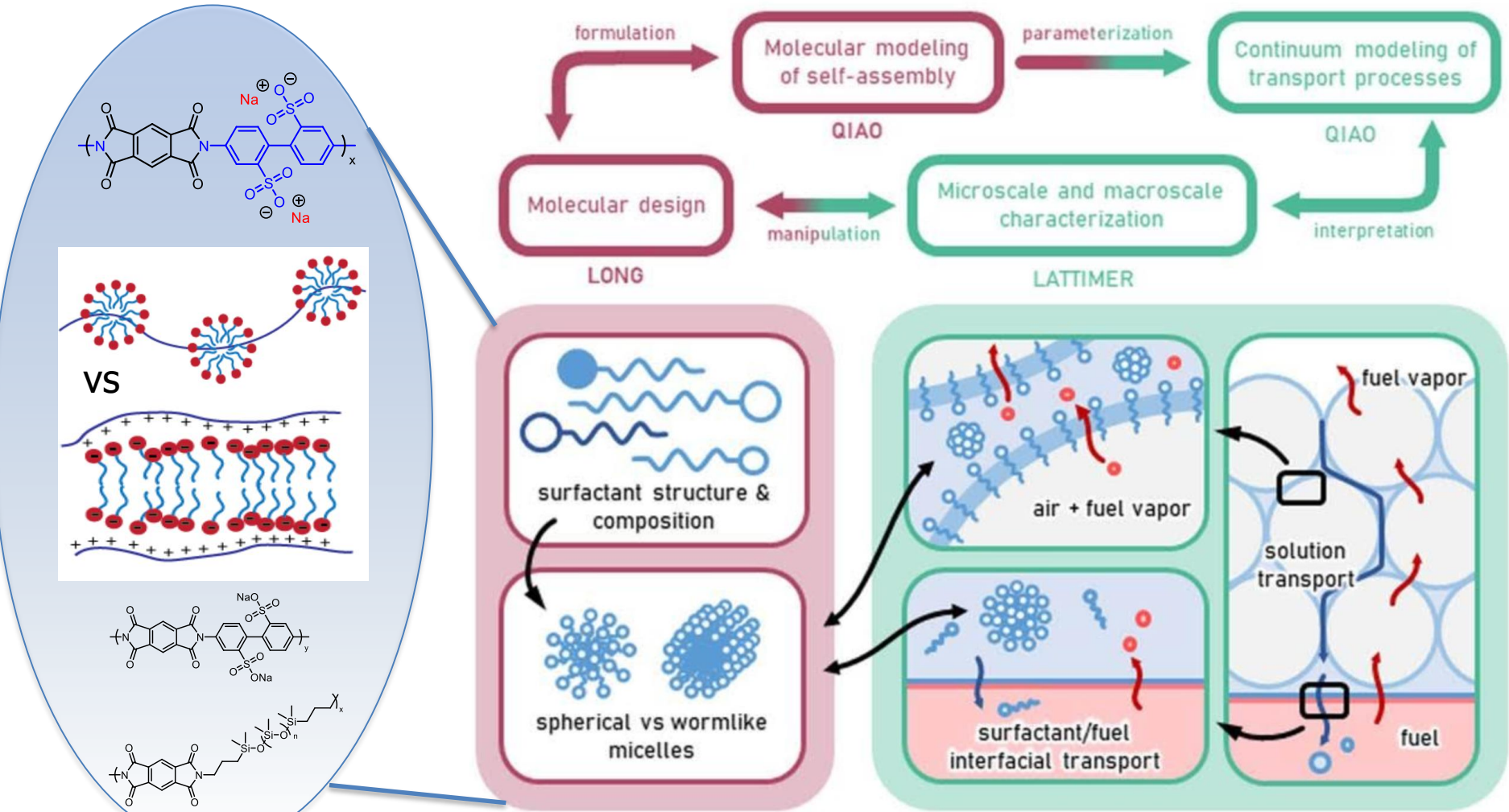

# Two-step polycondensation yields thermally stable sodiosulfonated polyimides

From pyromellitic dianhydride (**PMDA**), sodium salt of 4,4'-diamino diphenyl 2,2'-disulphonic acid (**BDSA-Na**) and 4,4'-oxydianiline (**ODA**)

➤ 100-50 mol% **BDSA-Na**: **ODA**

After imidization up to 400 °C, free-standing films, deep brown, with varying flexibility

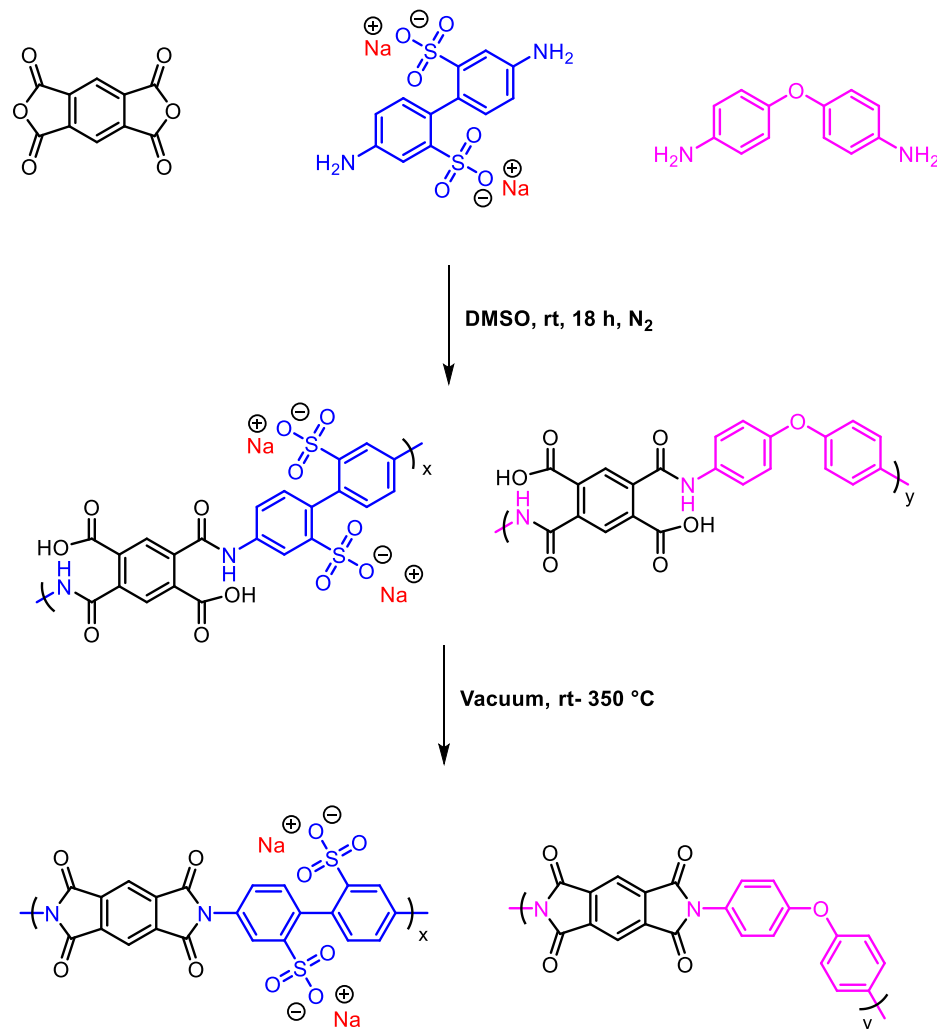

# Thermal characterization reveals high char yields and competitive weight loss temperatures

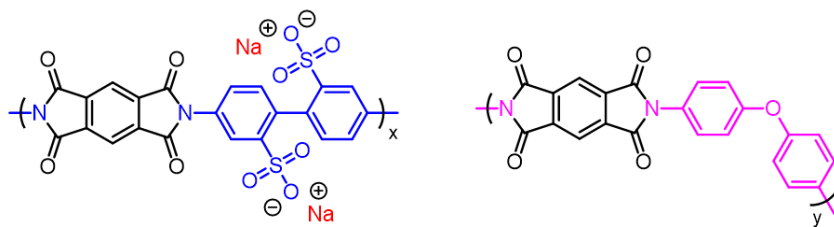
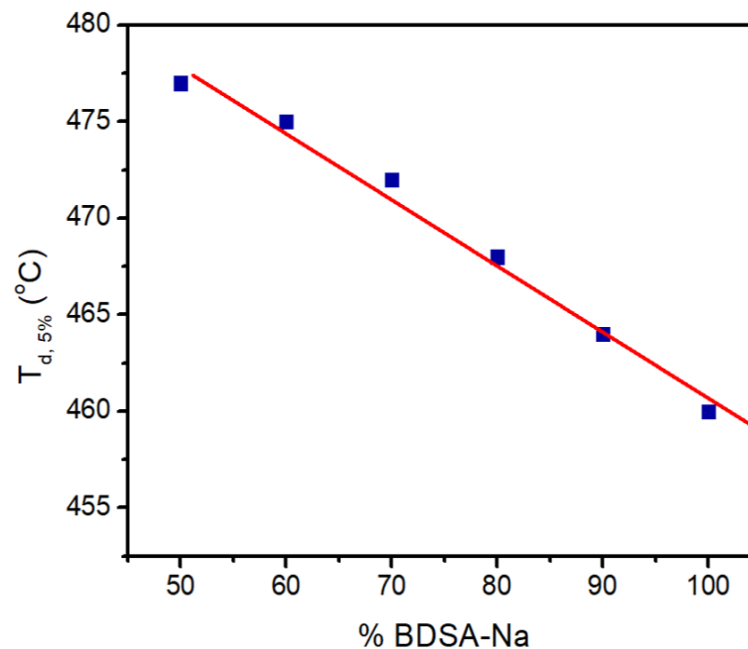
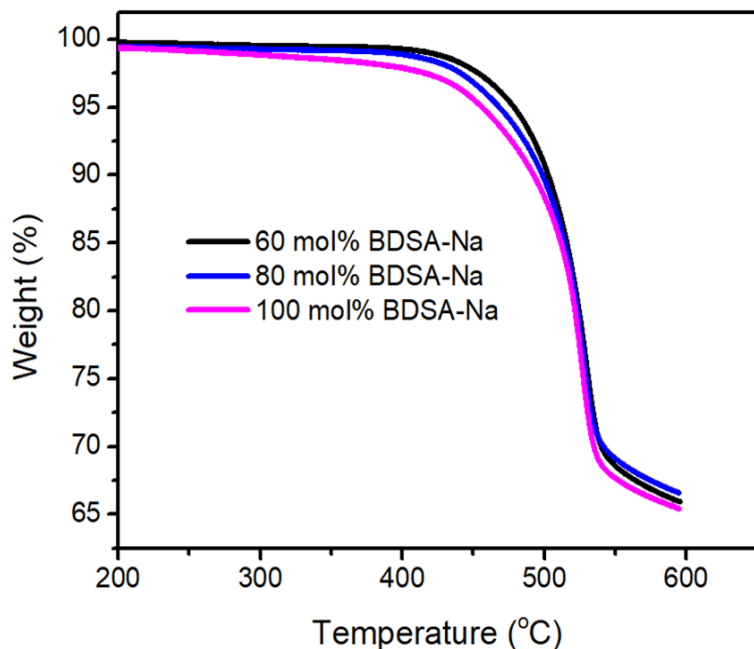

- $T_{d,5\%}$  remains the same under air, 60-70%
- Changes in char yields are negligible between different polymers

# Preliminary ecotoxicology provides insight into environmental effects

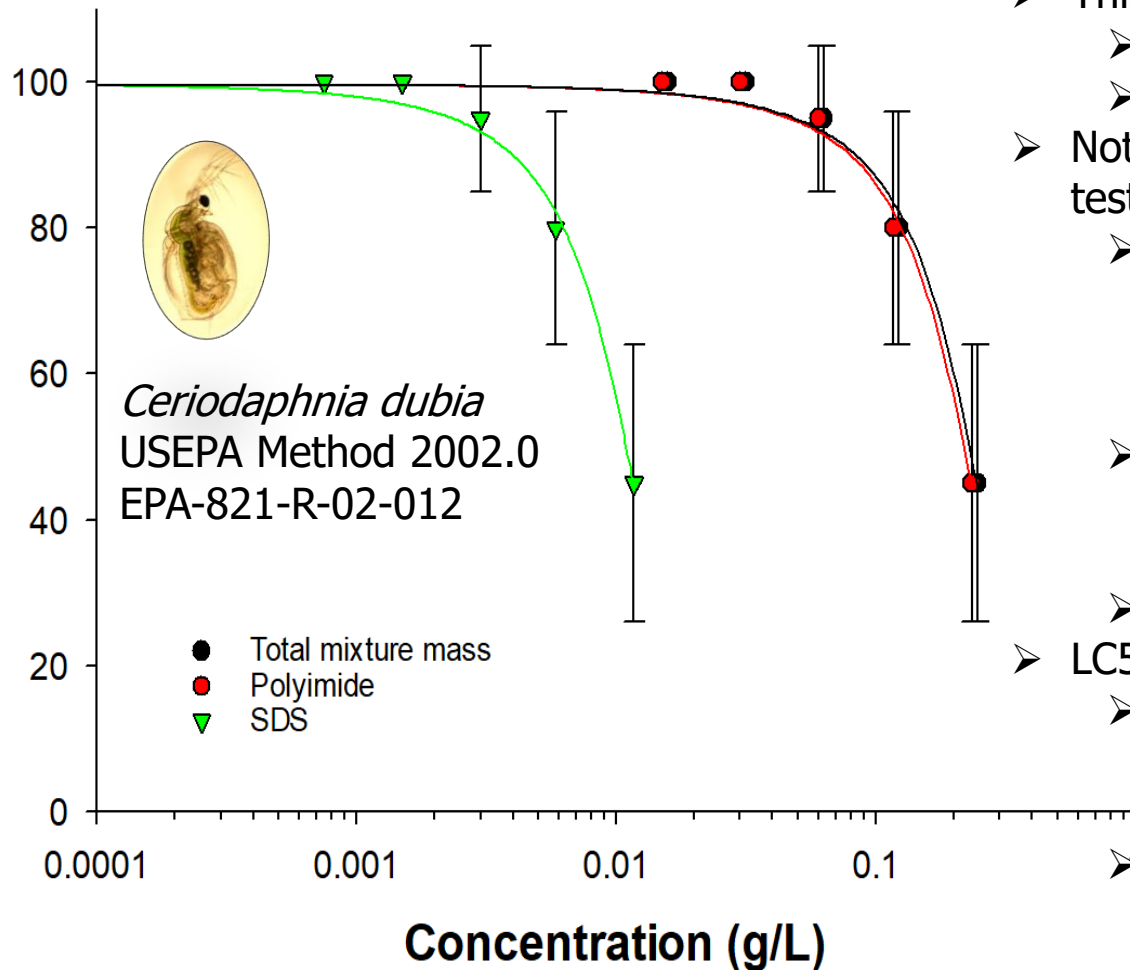

- This is a mixture
  - Cause for toxicity **uncertain**
  - Polyimide + SDS
- Note: only single 48-hour acute toxicity test conducted on the mixture
  - Concentrations expressed as individual constituents from the mixture (from one test) but there may be synergistic effects
  - **Individual constituent tests not conducted but are planned**
  - All concentrations nominal
- LC50 values (nominal)\*
  - Expressed in terms of polyimide
    - LC50 = **216 (162 – 430) mg/L\***
  - Expressed in terms of SDS
    - LC50 = **11 (8 – 21) mg/L\***

# Solution viscosity models and predicts solution behavior

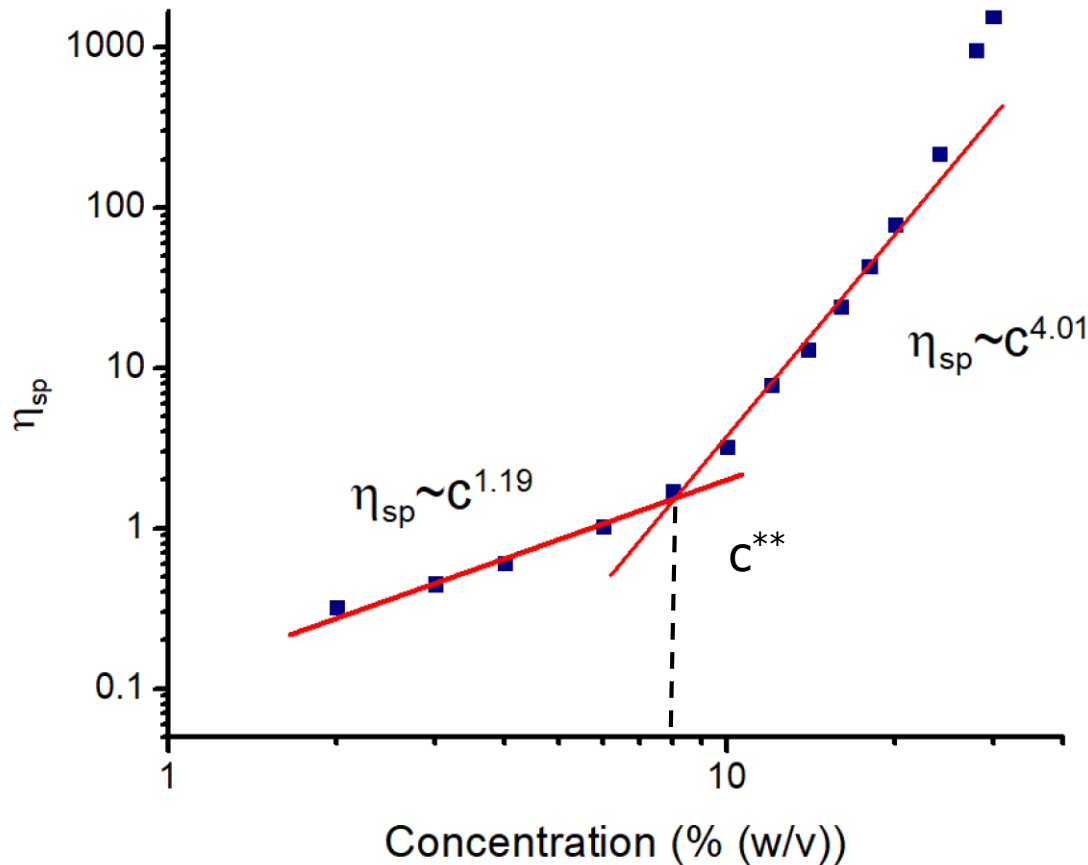

- $C^{**}$ , crossover into entanglement  $\sim 8$  wt.%
- Deviations at high concentrations due to lower molecular wt. polymer and dispersity
- Scaling theory indicates a polyelectrolyte solution with salt present!
  - Not quite at neutral limit
  - Being studied further

# Fully water soluble, foam-forming polyimides at high degrees of sulfonation

## PIs with 100 and 75 mol% **BDSA-Na**, fully water soluble

- Minimal foam-forming ability in unmodified polymer solution
- Addition sodium dodecyl sulfate (SDDS), produced stable foams after agitation

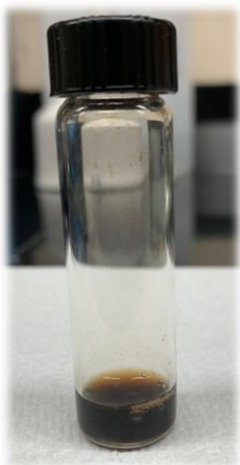
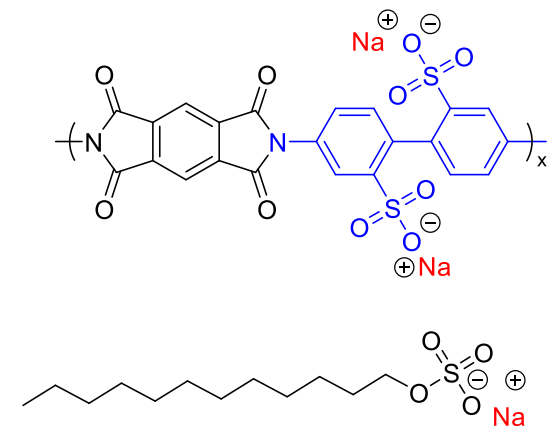

3 wt.% PI



0.12 wt.% SDS 0.12 wt.% SDS  
3 wt.% PI



Foamed formulation

# Synthesis and neutralization of sulfonated polyamic acid (sPAA) with photolabile amine provides route to crosslinkable polymer surfactants

## Simplified synthetic route

- Require diminished sulfonation for water dispersibility
- Neutralization of poly(amic acid) with various basic molecules allows for tuning of surfactant performance
- Inclusion of polymerizable unit may enable gel formation during flame suppression
- Exploring additional pathways based on backbone surfactant tethering

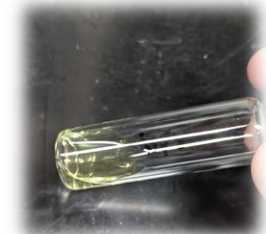

4 wt. % sPAAs in H<sub>2</sub>O

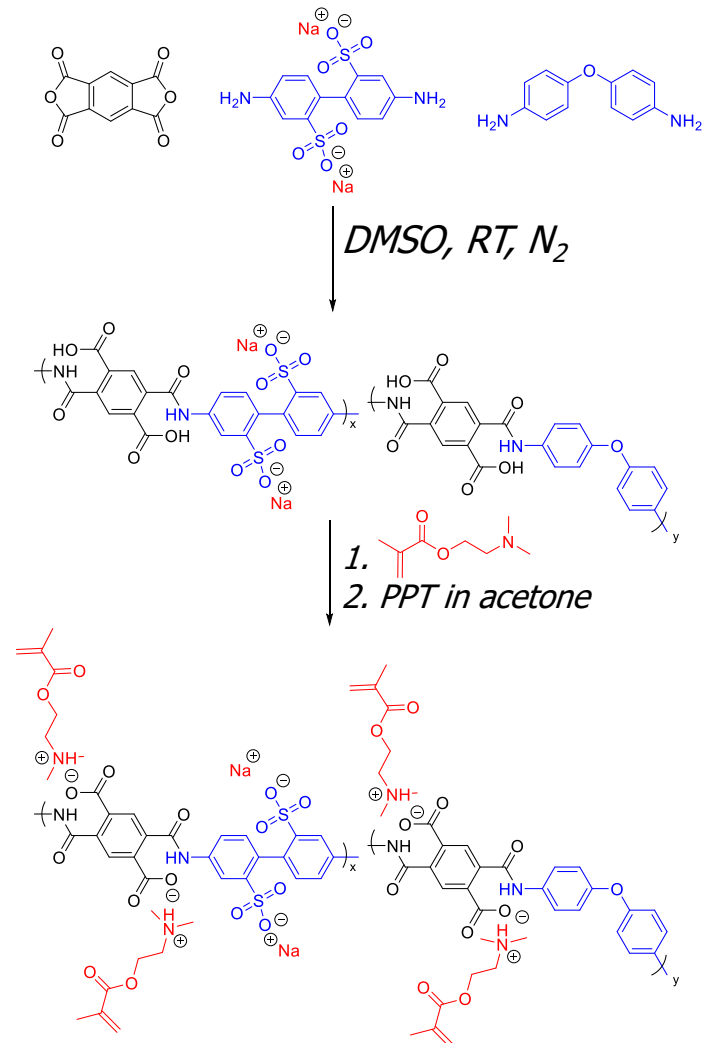

# High wt.% loading of sPAAs with photoinitiator permits photocrosslinking of fully aromatic polymer from water

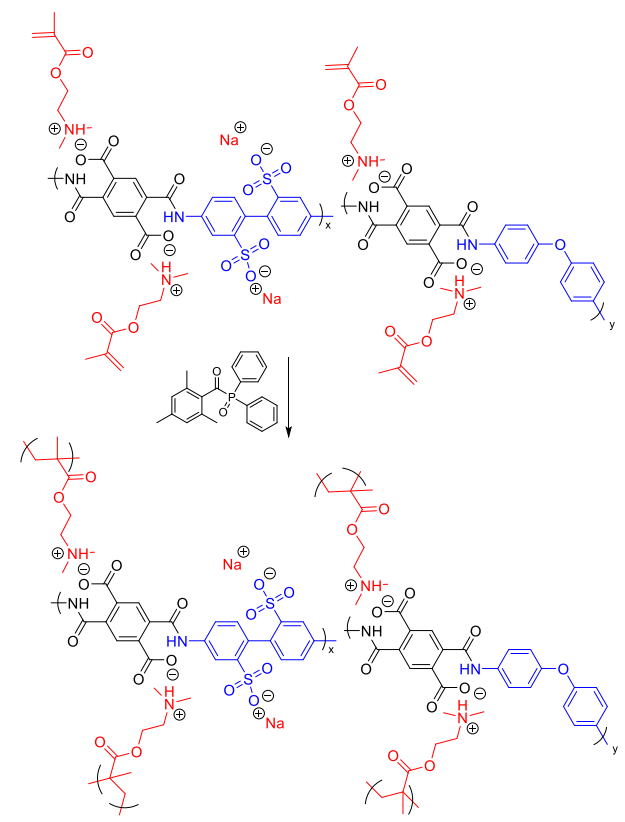
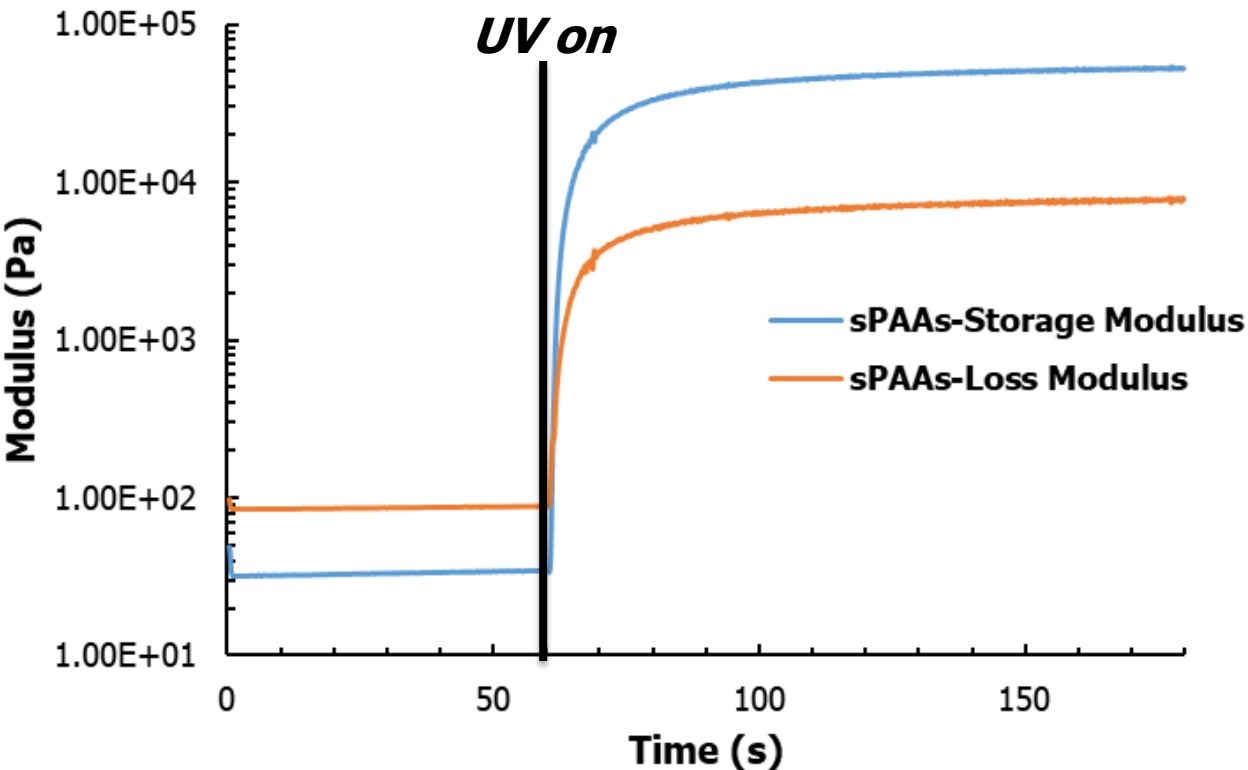

- 20 wt.% sPAAs in DI water
  - 2.5 wt.% TPO relative to sPAAs
- **1.3 s crossover time**

# Formulating sPAAs with alkyl surfactant, NaCl and glycolic ether enable production of stable foam

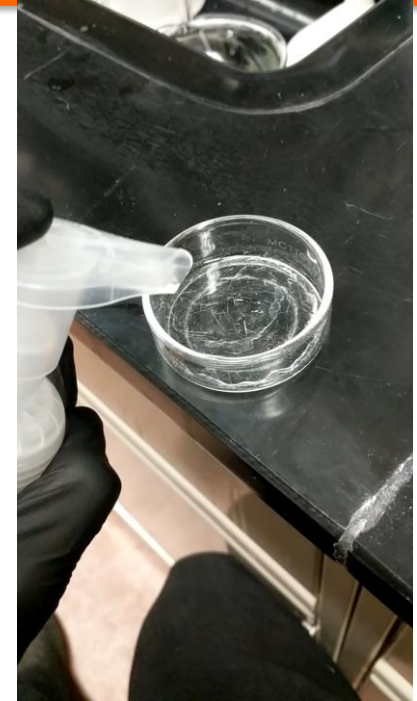
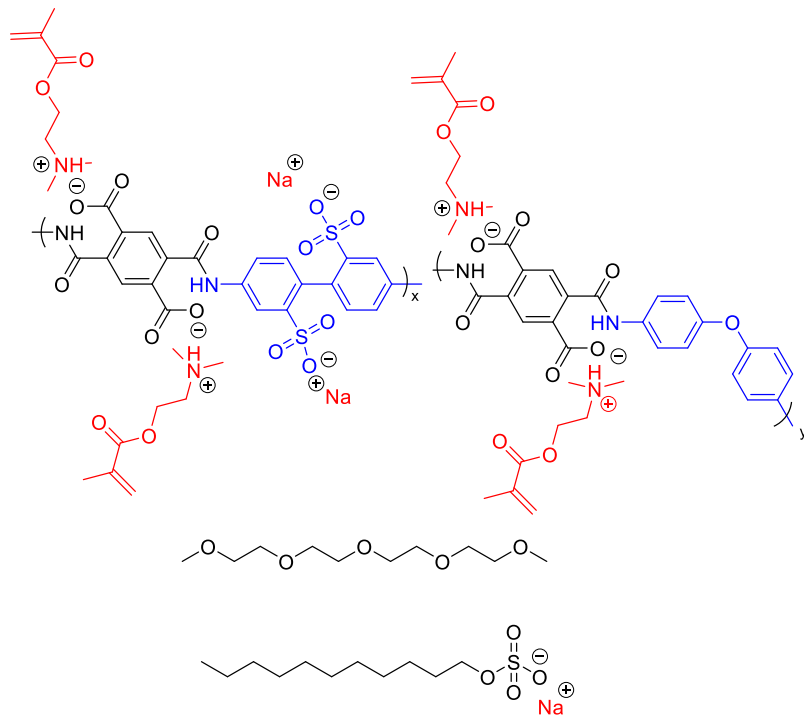

- Solution contains 4 wt.% sPAAs, 1 wt.% SDS, 1 wt.% NaCl and 1 wt.% tetraethylene glycol dimethyl ether in DI water
  - **Foam exhibited stability for > 30 min in petri dish**
- ✓ ER and DT reported are similar to Gen 1, if not marginally better

# Numerous polyimide/ poly(amic acid) “generations” attempt to combat liquid fuel fires

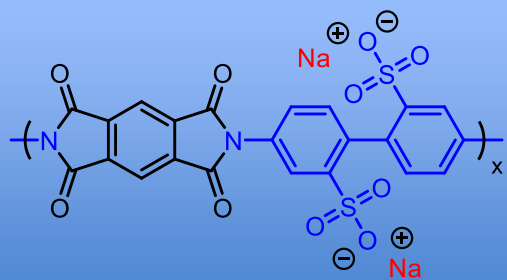

**sPI**

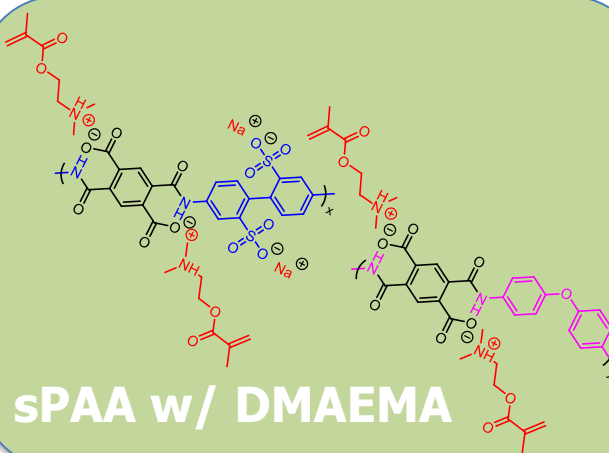

**sPAA w/ DMAEMA**

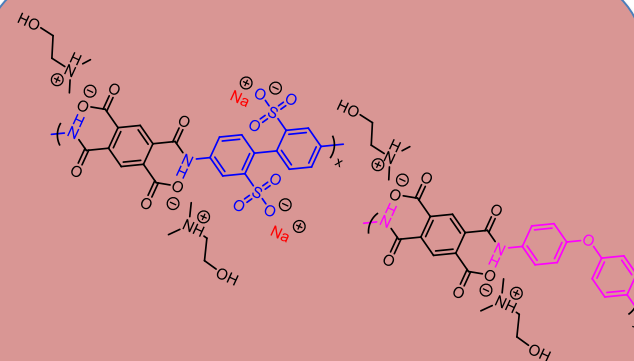

**sPAA w/ DMAE**

## Polymer Formulation

## Description

Generation 1

3 wt% sPI, 0.15 wt% SDS

Generation 1, revision 1

6 wt% sPI, 0.15 wt% SDS

Generation 2

3 wt% sPAAs w/ DMAEMA, 0.3 wt% SDS

Generation 3

3 wt% sPI, 0.15 wt% SDS, 0.3 wt% MTPP-Br,  
0.3 wt% NaCl

Generation 4

3 wt% sPAAs w/ DMAE, 0.15 wt% SDS

Generation 5

3 wt% sPAAs w/ DMAE, 0.15 wt% SDS, 1 wt%  
MTPP-Br

Generation 6

3 wt% 40:60 sPI (Gen1): sPAAs w/ DMAE  
(Gen4), 0.15wt% SDS

Generation 7

3wt% 50:50 sPAAS with DMAEMA (Gen2): sPAAs  
w/ DMAE (Gen4), 0.3 wt% SDS

# Measurement of foam expansion/ drainage conducted in accordance NFPA 412

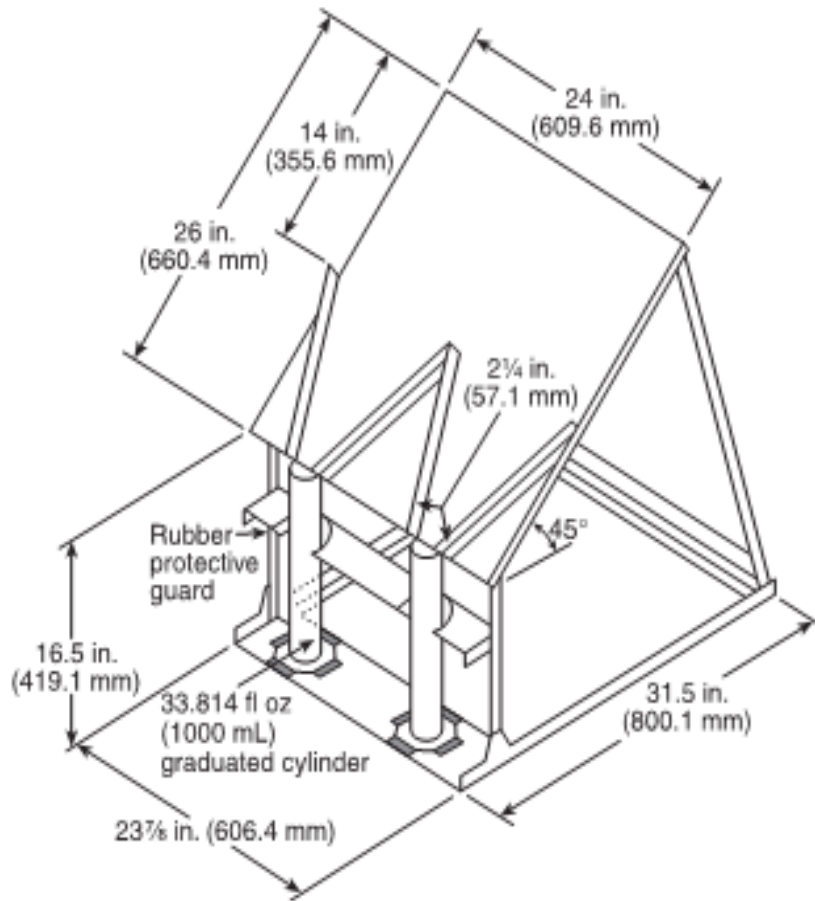

NFPA 412- "Standard for Evaluating Aircraft Rescue and Fire-Fighting Foam Equipment"



JENSEN HUGHES

Advancing the Science of Safety

- **AFFFs are tested against a very strict US Military requirement- The "Mil Spec"- MIL-F-24385F**
  - Drainage Time- maximum 25% drainage in 2.5 min
  - Expansion Ratio- >5, foam volume 5x greater than liquid volume
  - Foam sprayed from the 2 GPM MilSpec nozzle at 4-6 ft
  - Weight of the cylinder measured to determine expansion ratio of the foam, quotient of the volume (mL) and the mass (g)

# Small scale testing at Jensen Hughs provides platform for foam screening

Test Class (Severity)	MIL-SPEC Pool Fire Test Basis	Pre-burn Time (s)	Foam Added for Ext. (g)	Foam Added After Ext. (g)	MIL-SPEC Test Basis
A (Least)	28 ft <sup>2</sup>	10	405	None	90 seconds of 2 GPM foam applied to 28 ft <sup>2</sup> pool fire

1 ft X 1 ft X 2 in

After preburn duration, foam is poured from top of flames into the center of the pan

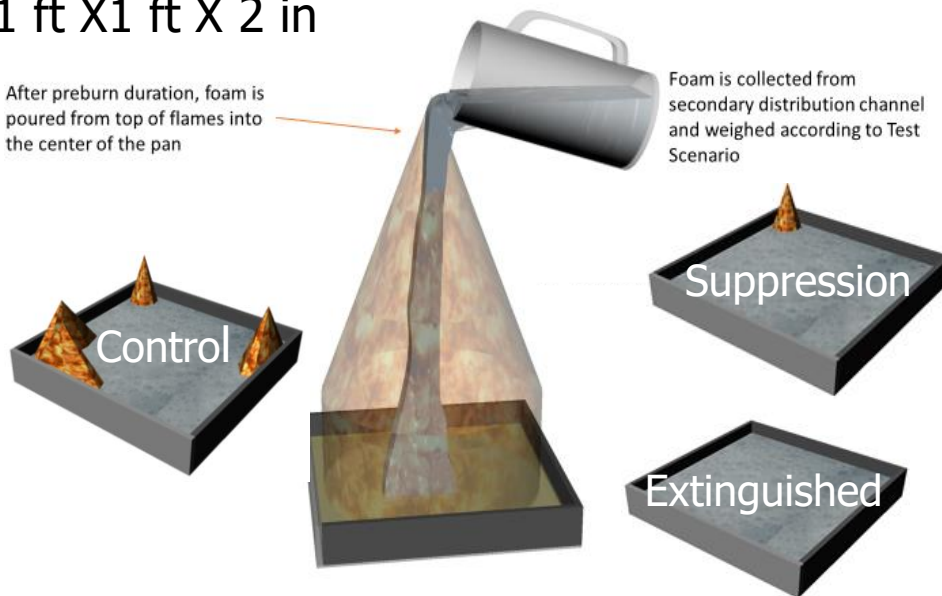

3.3 in X 1.5 in

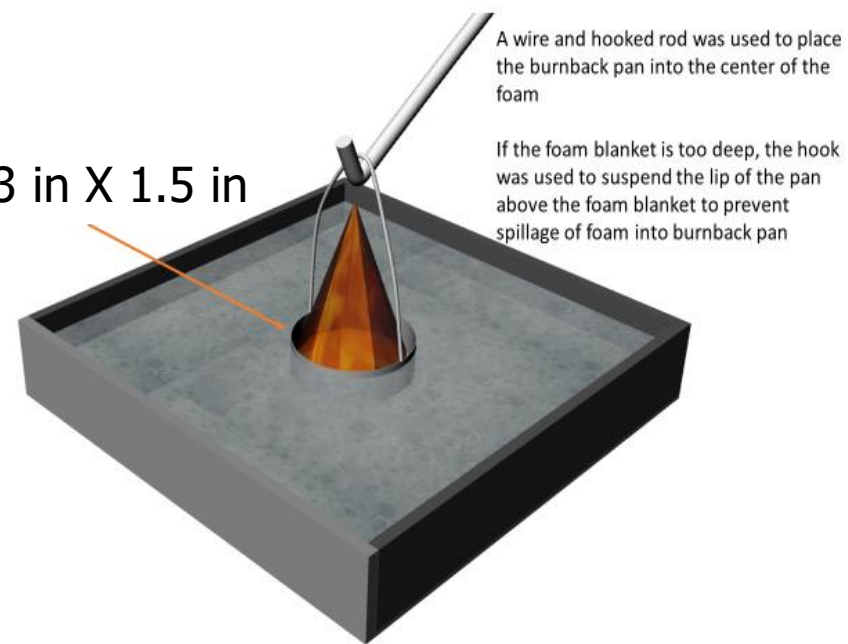

# Initial Foam Testing of Generation 1, meets MIL-SPEC ER/DT

## Foams tested using MIL-SPEC nozzle against MIL-F-24385F requirements<sup>2</sup>

- Max 25% drainage, 2.5 min
- Expansion ratio  $\geq 5$

### Average 25% Drainage

- $3.80 \pm 0.08$  min

### Average Expansion Ratio

- $6.93 \pm 0.16$

### Burnback

- Some suppression but low fluidity



**3 wt.% PI**

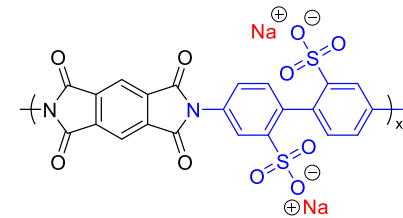

**0.12 wt.% SDDS**

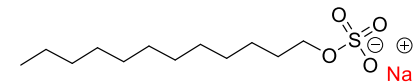

# Generation 2 foam crosslinks with heat, delaying ignition time and imparting fire control

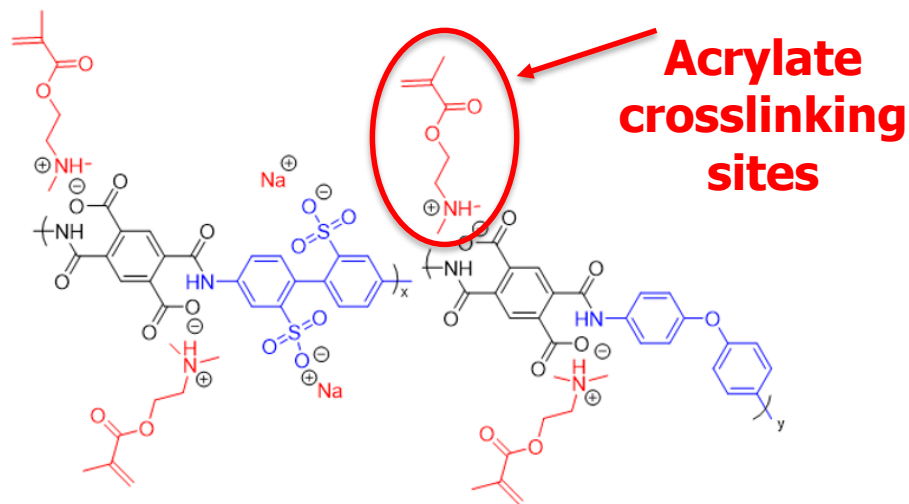

## Key Learnings of Gen 2 route:

- Simplified one-step synthetic strategy enables large scale
- **Cross-linking** of polymer exposed to higher radiant heating improves ignition resistance
  - Rapid control in fire test
- Only small flamlets exist on foam surface and edges after control
- Next Generations involve further modification of cationic site balance
  - Thermal stability
  - Gas phase interactions



# Generations 6 and 7 are successful in extinguishing fire

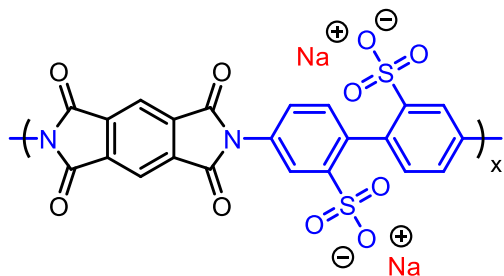

## ➤ Generation 6

➤ Extinguishment:  
25 sec

➤ 25% Burnback:  
20 sec

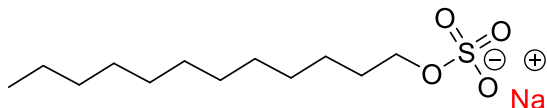
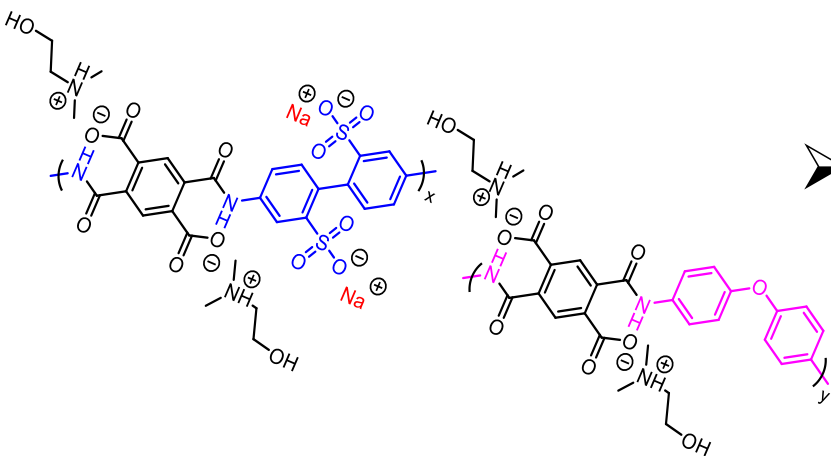

40 sPI:60 sPAAs; 0.15 wt% SDS

# Generations 6 and 7 are successful in extinguishing fire (Cont.)

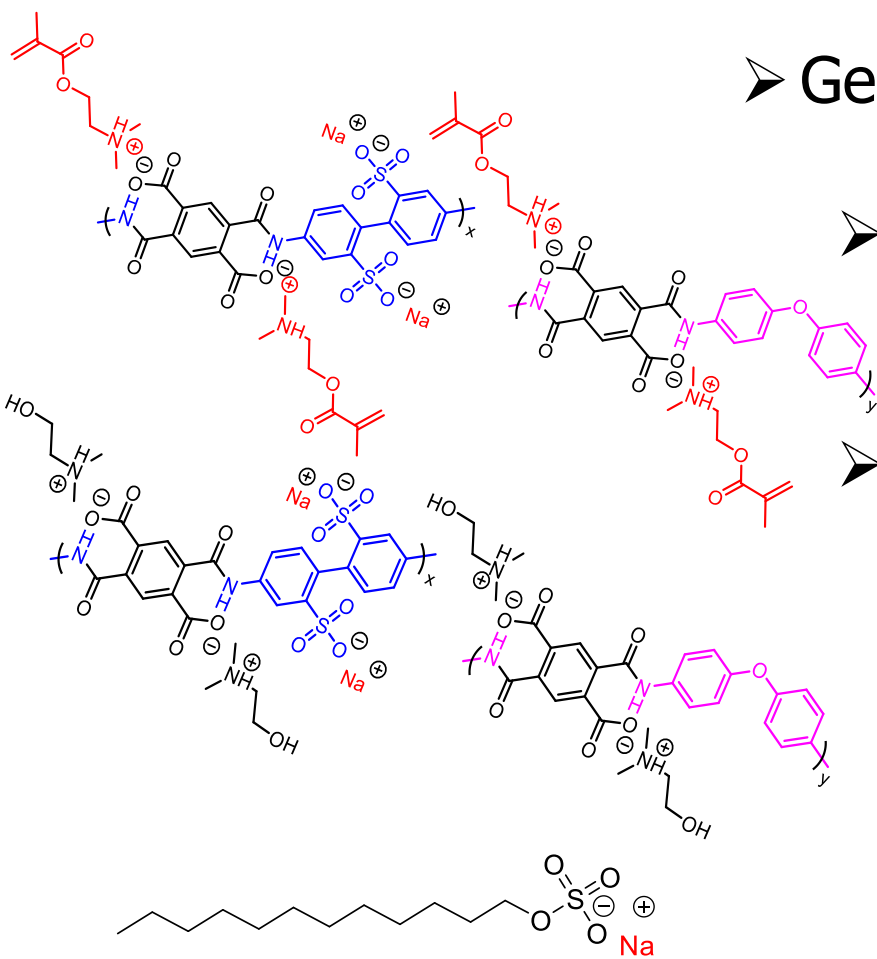

## ➤ Generation 7

➤ Extinguishment:  
55 sec

➤ 25% Burnback:  
15 sec



40 sPI:60 sPAAs; 0.15 wt% SDS

# Future Directions: Neutralization of sPAA with DMAE enables water solubility with phosphonium incorporation

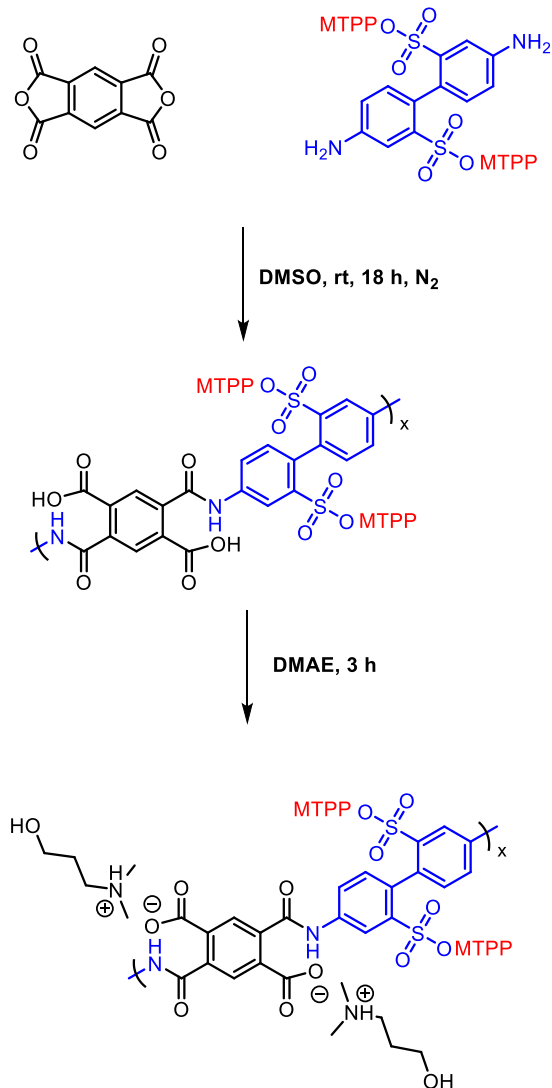

- Allows for simpler synthetic route with more control, modularity and potential added flame retardance with novel BDSA monomer
- Can vary mol% of phosphonium widely
  - Can combine with other types of monomers without hindering solubility
  - Aligns with SERDP trajectory

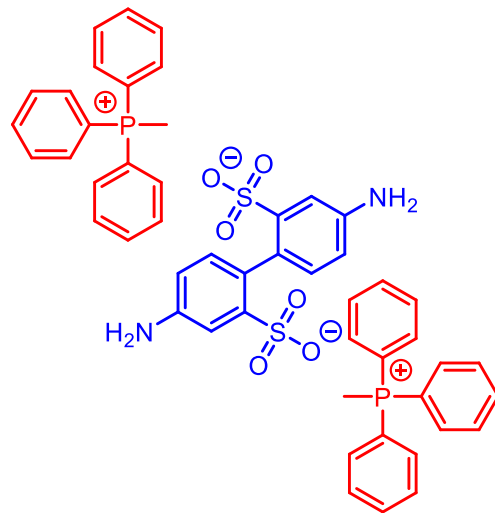

# Future Directions: Siloxane based foams to be another promising platform for fluorosurfactant replacement

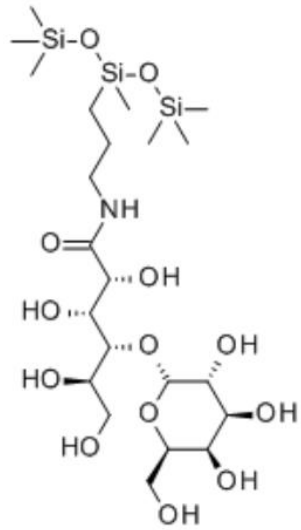

Surfactant 1

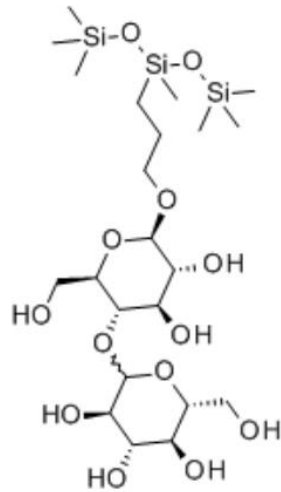

Surfactant 2

## Siloxanes and siloxane surfactants

- surface/ interfacial properties
- flame retardancy
- environmental friendliness

## Siloxane based foams **out-performed** other commercially available fluorine-free foams

- Not as good as AFFF however

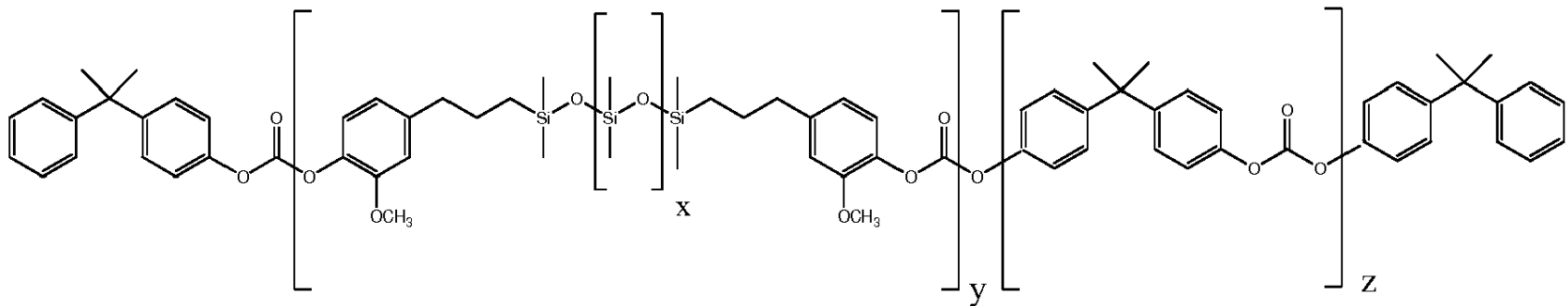

# Future Directions: Employment of grafted PIs as polymeric surfactants may improve flame suppression

## Nomex (*meta*-aramid) exhibits fantastic flame resistance<sup>1</sup>

- **Coupling with graft monomer may produce polymeric surfactant**
- Possible route to improved flame suppression
- **Tuning of graft density and composition dictate surfactant performance**
- Necessitates investigating toxicology of degradation products

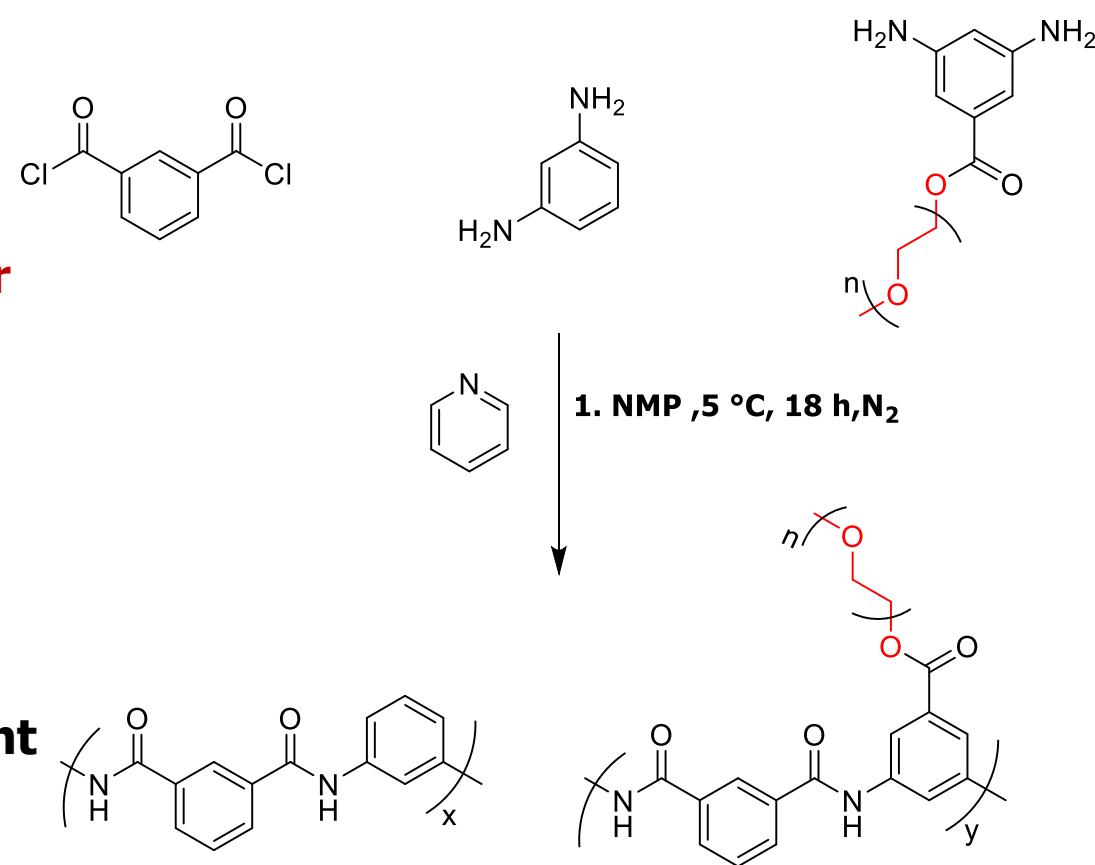

1. Foo, C. C.; Chai, G. B.; Seah, L. K. *Compos. Struct.* **2007**, *80*(4), 588–594.

# Sulfonated polyimides and poly(amic acids) provide a promising platform for AFFF replacement

## ➤ Design of commercially viable synthesis

- Commercially Available Starting Materials
- Existing Reactor Technology
- Existing Industrial Partnerships in place
- Modular polymers → facile customization

## ➤ Establishment of foam evaluation protocol

- Expansion ration, drainage time, burnback, stability evaluated at JH
- Ecotoxicology evaluated at Army EDRC

## ➤ Future Directions include additional modification

- Varying crosslinker content
- Phosphonium cations for added flame resistance and gas phase interactions
- Siloxane segmented copolymers for flame resistance and interfacial activity

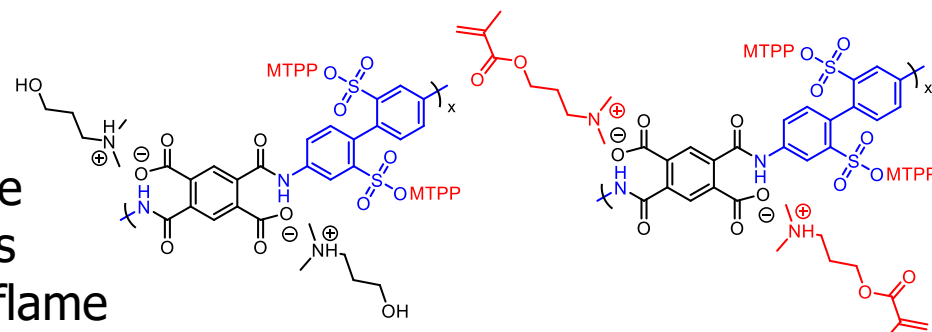
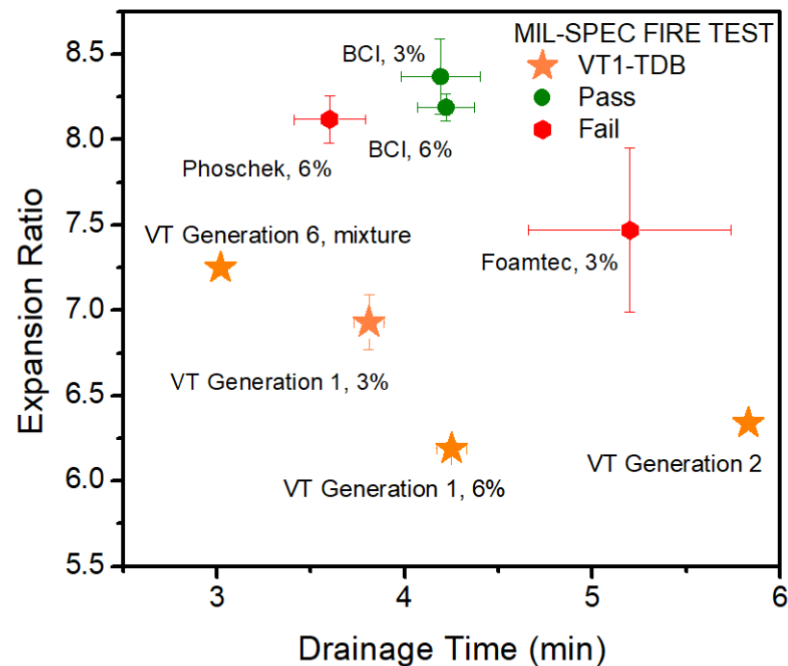

# Acknowledgements



MEETING DOD'S ENVIRONMENTAL CHALLENGES



Macromolecules  
Innovation Institute  
*At the intersection of science, engineering, and society*



COLLEGE OF SCIENCE  
**CHEMISTRY**  
VIRGINIA TECH.

JENSEN HUGHES

Advancing the Science of Safety

