



JENSEN HUGHES

SCREENING TESTS FOR PFAS FREE FIREFIGHTING FOAMS

Joshua Dinaburg, Research Engineer



AFFF PROJECT MEETING

2021 ♦ PFAS-Free Firefighting Foams



REPORT DOCUMENTATION PAGE

Form Approved
OMB No. 0704-0188

The public reporting burden for this collection of information is estimated to average 1 hour per response, including the time for reviewing instructions, searching existing data sources, gathering and maintaining the data needed, and completing and reviewing the collection of information. Send comments regarding this burden estimate or any other aspect of this collection of information, including suggestions for reducing the burden, to Department of Defense, Washington Headquarters Services, Directorate for Information Operations and Reports (0704-0188), 1215 Jefferson Davis Highway, Suite 1204, Arlington, VA 22202-4302. Respondents should be aware that notwithstanding any other provision of law, no person shall be subject to any penalty for failing to comply with a collection of information if it does not display a currently valid OMB control number.
PLEASE DO NOT RETURN YOUR FORM TO THE ABOVE ADDRESS.

1. REPORT DATE (DD-MM-YYYY) 31/08/2021		2. REPORT TYPE ESTCP Project Outbrief		3. DATES COVERED (From - To) 5/29/2019 - 5/31/2021	
4. TITLE AND SUBTITLE Screening Tests for PFAS-Free Firefighting Foams				5a. CONTRACT NUMBER 19-C-0027	
				5b. GRANT NUMBER	
				5c. PROGRAM ELEMENT NUMBER	
6. AUTHOR(S) Brian Lattimer, Jerry Back, Joshua Dinaburg Jensen Hughes, Inc. John Farley Naval Research Laboratory Brian Lattimer Virginia Tech				5d. PROJECT NUMBER WP19-5332	
				5e. TASK NUMBER	
				5f. WORK UNIT NUMBER	
7. PERFORMING ORGANIZATION NAME(S) AND ADDRESS(ES) Jensen Hughes, Inc. 2020 Kraft Drive, Suite 3020 Blacksburg, VA 24060				8. PERFORMING ORGANIZATION REPORT NUMBER WP19-5332	
9. SPONSORING/MONITORING AGENCY NAME(S) AND ADDRESS(ES) Environmental Security Technology Certification Program 4800 Mark Center Drive, Suite 16F16 Alexandria, VA 22350-3605				10. SPONSOR/MONITOR'S ACRONYM(S) ESTCP	
				11. SPONSOR/MONITOR'S REPORT NUMBER(S) WP19-5332	
12. DISTRIBUTION/AVAILABILITY STATEMENT DISTRIBUTION STATEMENT A. Approved for public release: distribution unlimited.					
13. SUPPLEMENTARY NOTES					
14. ABSTRACT The objective of this project was to develop a series of bench - scale tests that can predict the fire suppression and burnback performance of candidate foams in accordance with Military Specification MIL - PRF - 24385F (SH), Amendment 2.					
15. SUBJECT TERMS Screening Tests, PFAS-Free Firefighting Foams					
16. SECURITY CLASSIFICATION OF:			17. LIMITATION OF ABSTRACT UNCLASS	18. NUMBER OF PAGES 39	19a. NAME OF RESPONSIBLE PERSON Brian Lattimer
a. REPORT UNCLASS	b. ABSTRACT UNCLASS	c. THIS PAGE UNCLASS			19b. TELEPHONE NUMBER (Include area code) 540-808-2800

TECHNICAL OBJECTIVES

The objective of this project was to develop a series of bench-scale tests that can predict the fire suppression and burnback performance of candidate foams in accordance with Military Specification MIL-PRF-24385F (SH), Amendment 2.

	
<ul style="list-style-type: none"> + 28 ft² test fire + 6 ft diameter steel pan + 2 gpm MILSPEC nozzle + 30 second max extinguishing time (full strength fresh water) 	<ul style="list-style-type: none"> + 50 ft² test fire + 8 ft diameter steel pan + 2 gpm MILSPEC nozzle + 50 second max extinguishing time

Firefighting Performance Requirements of MIL-PRF-24385F	
28 ft² Fire Tests and Required Extinguishment Time (s)	
Fresh Water 1/2 strength	<45
Fresh Water full strength	<30
Saltwater 1/2 strength	<45
Saltwater full strength	<30
Fresh water Quintuple Strength	<55
Burn Back Time (s)	
Fresh Water 1/2 strength	>300
Fresh Water full strength	>360
Saltwater 1/2 strength	>300
Saltwater full strength	>360
Fresh water Quintuple Strength	>200
50 ft² Fire Test and Required Extinguishment Times (s) (Saltwater Only)	
Extinguishment time (s)	<50
Burn back time (s)	>360
40 second summation	>320

UNDERLYING PHYSICAL MECHANISMS

- Suppression:

- Foam fluidity and ability to spread over fuel.
- Foam stability under influence of radiative heat.

- Burnback:

- Foam stability under influence of radiative heat.
- Foam stability over heated fuel.

Qualification
Fire Tests

Bench-Scale
Mechanism Tests

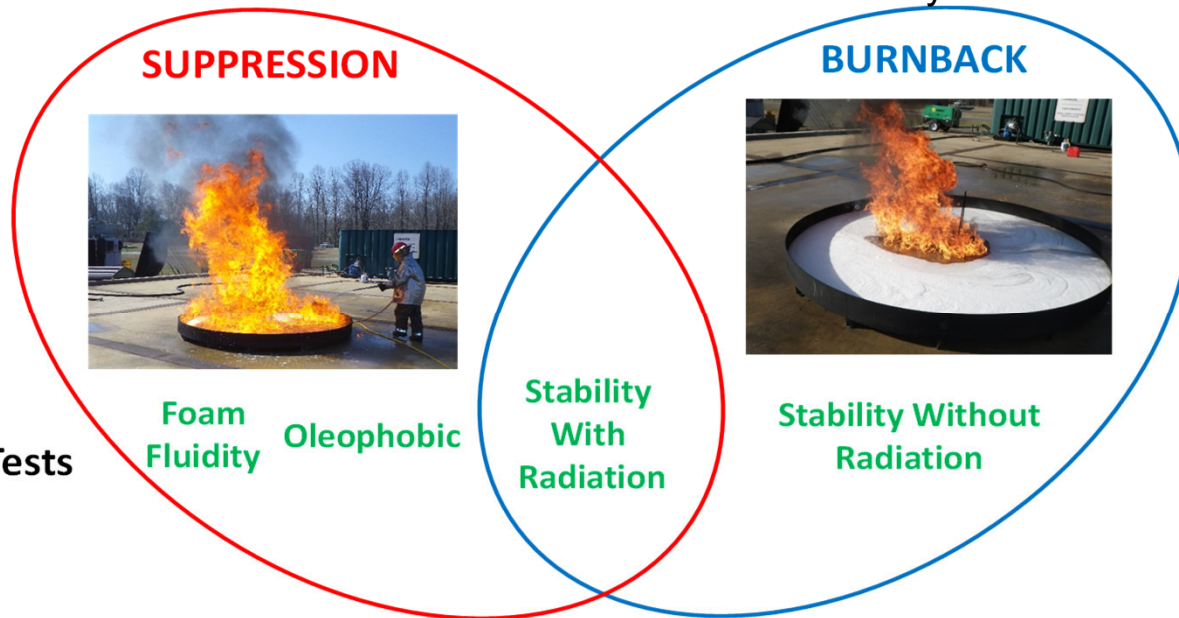

PERFORMANCE OBJECTIVES

Performance Objective	Data Requirements	Success Criteria
Quantitative Performance Objectives		
Foam Quality Equal foam quality to 2 GPM MIL-SPEC nozzle	<ul style="list-style-type: none"> Expansion Ratio Drainage Time 	Measurements of ER and DT equal to 2 GPM nozzle
Foam Fluidity	<ul style="list-style-type: none"> Rate of Spread Area Coverage 	Spread of foam relates to MIL-SPEC 28ft ² extinguishing performance
Stability on Heated Fuel	<ul style="list-style-type: none"> Rate of foam drainage Rate of foam/fuel evaporation Prevention of ignition of fuel vapors 	Vapor retention of foam relates to MIL-SPEC 28ft ² extinguishing and burnback performance
Stability under Radiation	<ul style="list-style-type: none"> Rate of foam drainage Rate of foam/fuel evaporation Prevention of ignition of fuel vapors 	Vapor retention of foam relates to MIL-SPEC 28ft ² extinguishing and burnback performance
Extinguishing	Quantity of foam needed to extinguish small fire Time to extinguish fire	Extinguishing time and foam application density relate to MIL-SPEC 28ft ² extinguishing performance
Burnback	Time to prevent 25% burnback at reducing quantities of foam	Burnback time and foam application density relate to MIL-SPEC 28ft ² burnback performance
Qualitative Performance Objectives		
Scale of tests	Tests can be conducted at bench-scale in Jensen Hughes Laboratory	No scale up of tests needed beyond bench to correlate to MIL-SPEC 28ft ² extinguishing and burnback testing
Consumption of foam concentration	Limit foam solution used	Require less total foam than MIL-SPEC 28ft ² extinguishing and burnback testing



MIL-SPEC PERFORMANCE

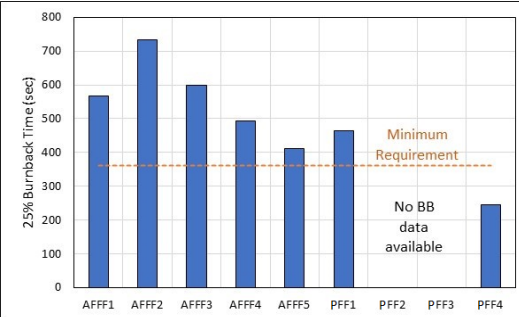

Name	Foam Type	Concentrate	MIL-SPEC Qualified
AFFF1	C6 HC AFFF	Type 3 (3%)	X
AFFF2	C6 HC AFFF	Type 6 (6%)	X
AFFF3	C6 HC AFFF	Type 3 (3%)	X
AFFF4	C6 AR AFFF	Type 3 (3%)	
AFFF5	C6 AR AFFF	Type 6 (6%)	
PFF1	HC-PFF	Type 3 (3%)	
PFF2	AR-PFF	Type 3 (3%)	
PFF3	AR-PFF	Type 3 (3%)	
PFF4	AR-PFF	Type 3 (3%)	

28 ft² MIL-SPEC Tested All Foams



- 28 ft² test fire
- 6 ft diameter steel pan
- 2 GPM MIL-SPEC nozzle
- 30 second max extinguishing time (full strength fresh water)
- 60 second additional foam application before burnback
- 360 second burnback resistance

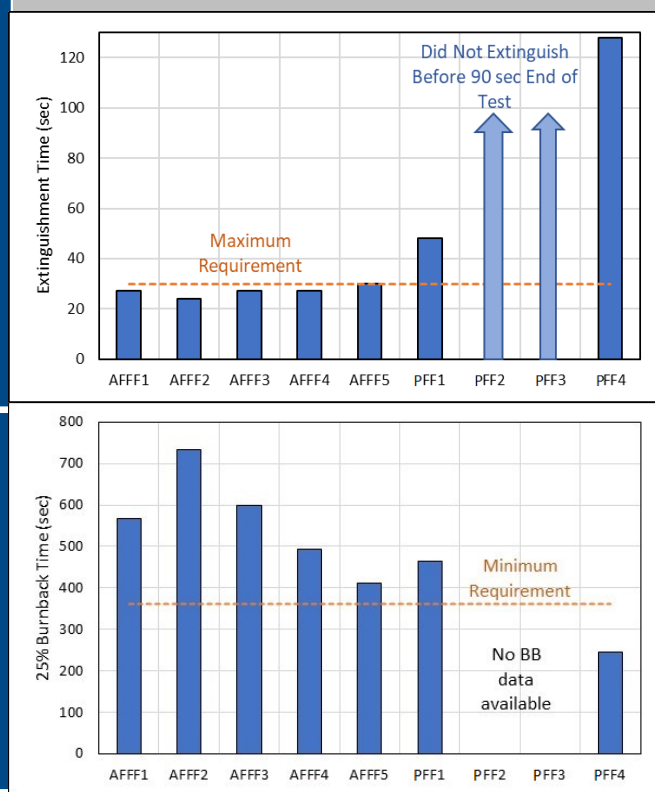

BENCH-SCALE TEST METRICS

Suppression and Burnback

- Directly assess the ability of a foam to suppress a fire and to resist burnback in a bench-scale pool fire.
- Performance metrics:
 - Directly related to full-scale (time to extinguishment, time to 25% burnback).

Stability

- Assess foam stability with and without radiative heating, over a heated and non-heated fuel layer.
- Performance metrics:
 - Mass of foam drained and evaporated, rates of drainage and evaporation, time to ignition.

Fluidity

- Ability of foam to spread over a layer of fuel.
- Performance metrics:
 - Velocity of foam as it spreads over fuel, coverage rates, mass of foam applied.

Mechanism	Foam Fluidity	Stability With Radiation	Stability Without Radiation
Test	Foam Flow Over Liquid	Foam Layer with Radiation	Foam Layer on Heated Fuel
Data	+ Foam height	+ Foam height depletion	+ Foam breakdown
	+ Spread velocity	+ Drainage rate	+ Time to ignition
	+ Radiation Effects	+ Evaporation rate	+ Drainage rate
	+ Burnback velocity	+ Critical foam mass	+ Expansion ratio
		+ Time to ignition	
		+ Radiation effects	

FOAM QUALITY

- Measured using 2 gpm MIL-SPEC nozzle and backboard

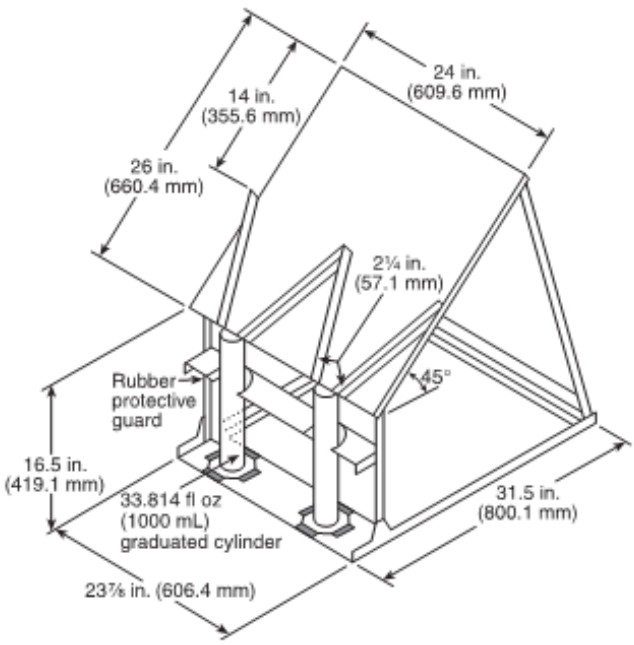
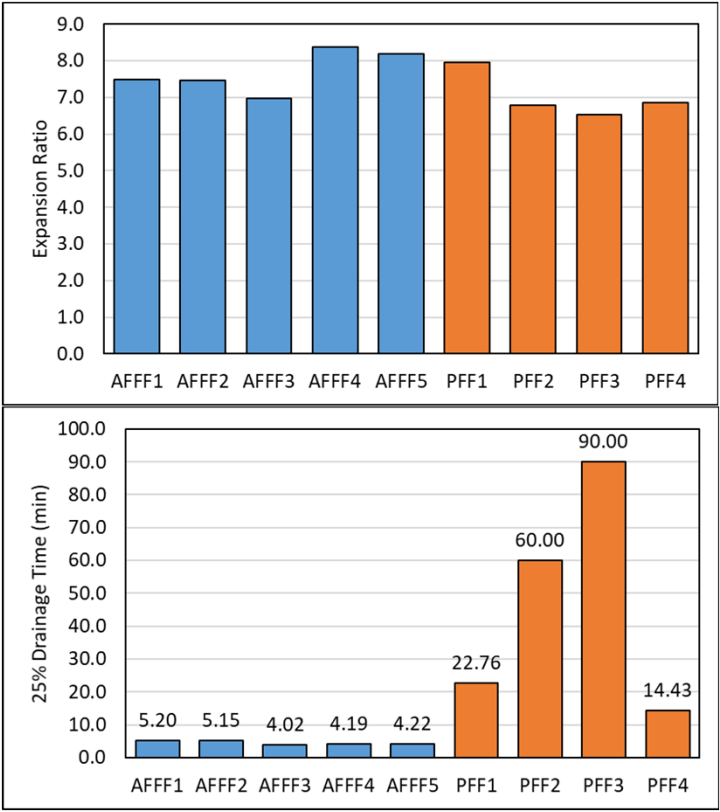

FOAM QUALITY – REDUCED NOZZLES

- Attempted to reproduce MIL-SPEC foam with reduced flow nozzle
- Limited success, not achieved for all foam formulations with same nozzle
- For consistency, developed a diverter to maximum foam usage from 2 gpm nozzle

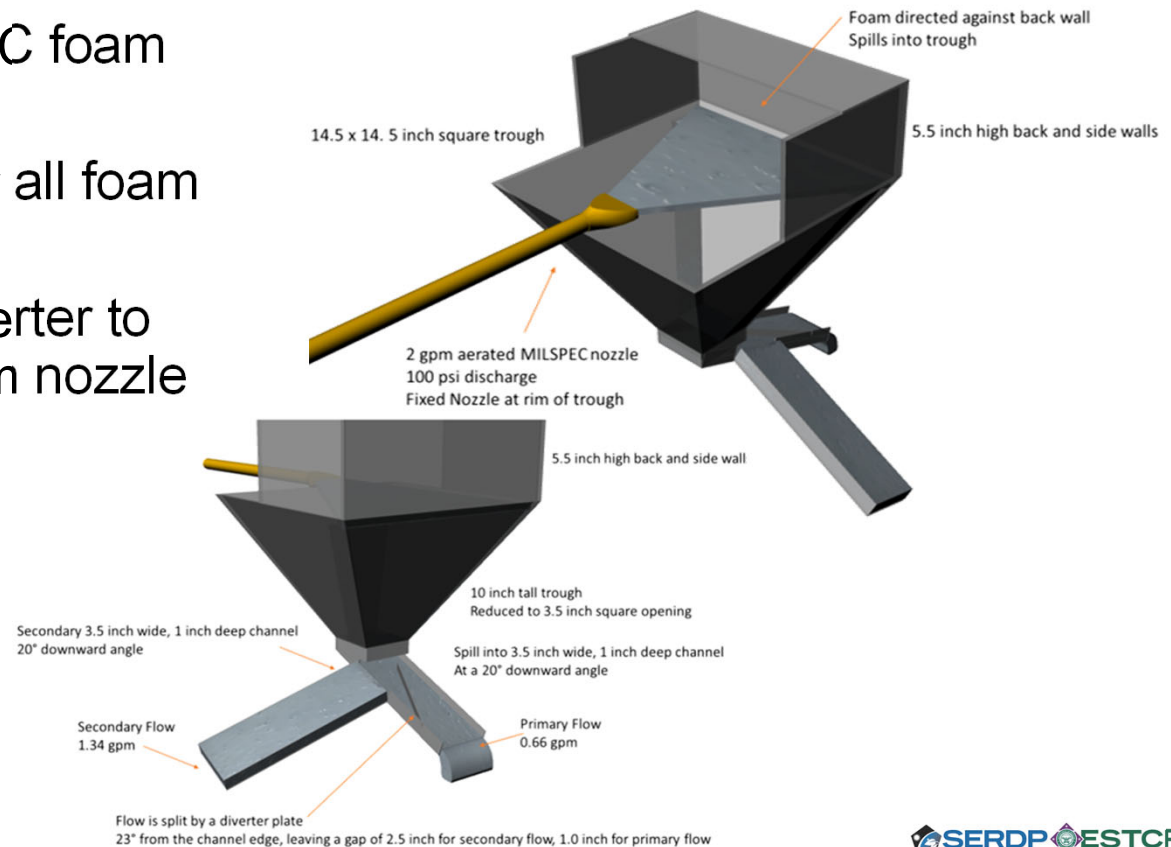
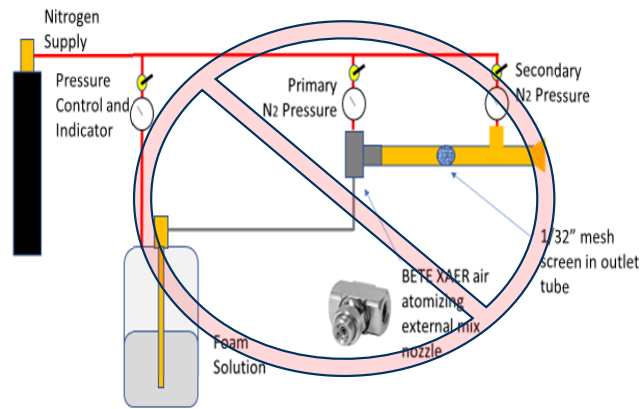

8

FLUIDITY

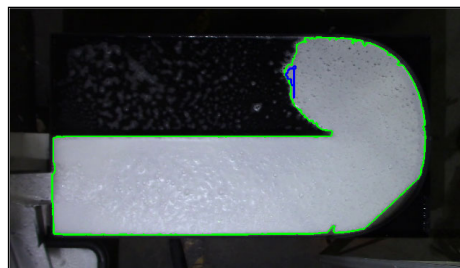
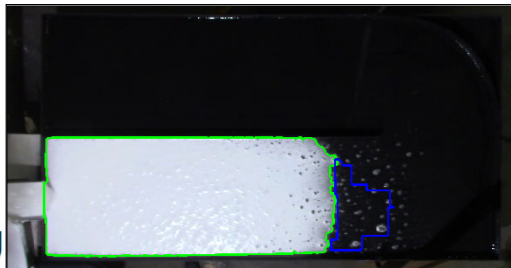
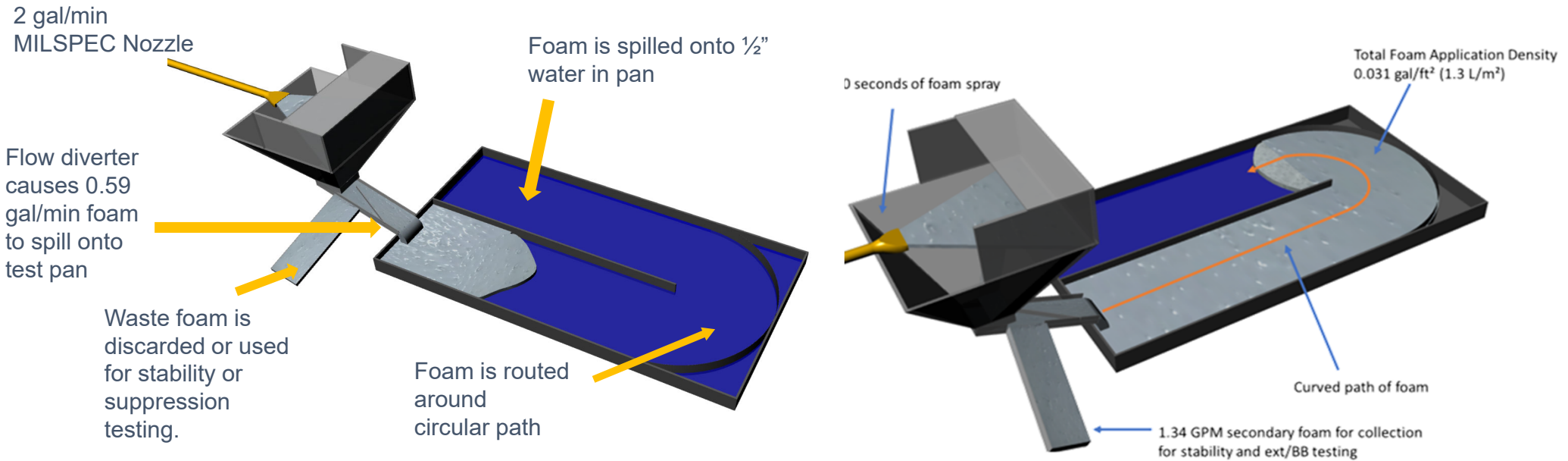

Foam spreading rate and coverage area is measured continuously by image analysis tool.

FLUIDITY

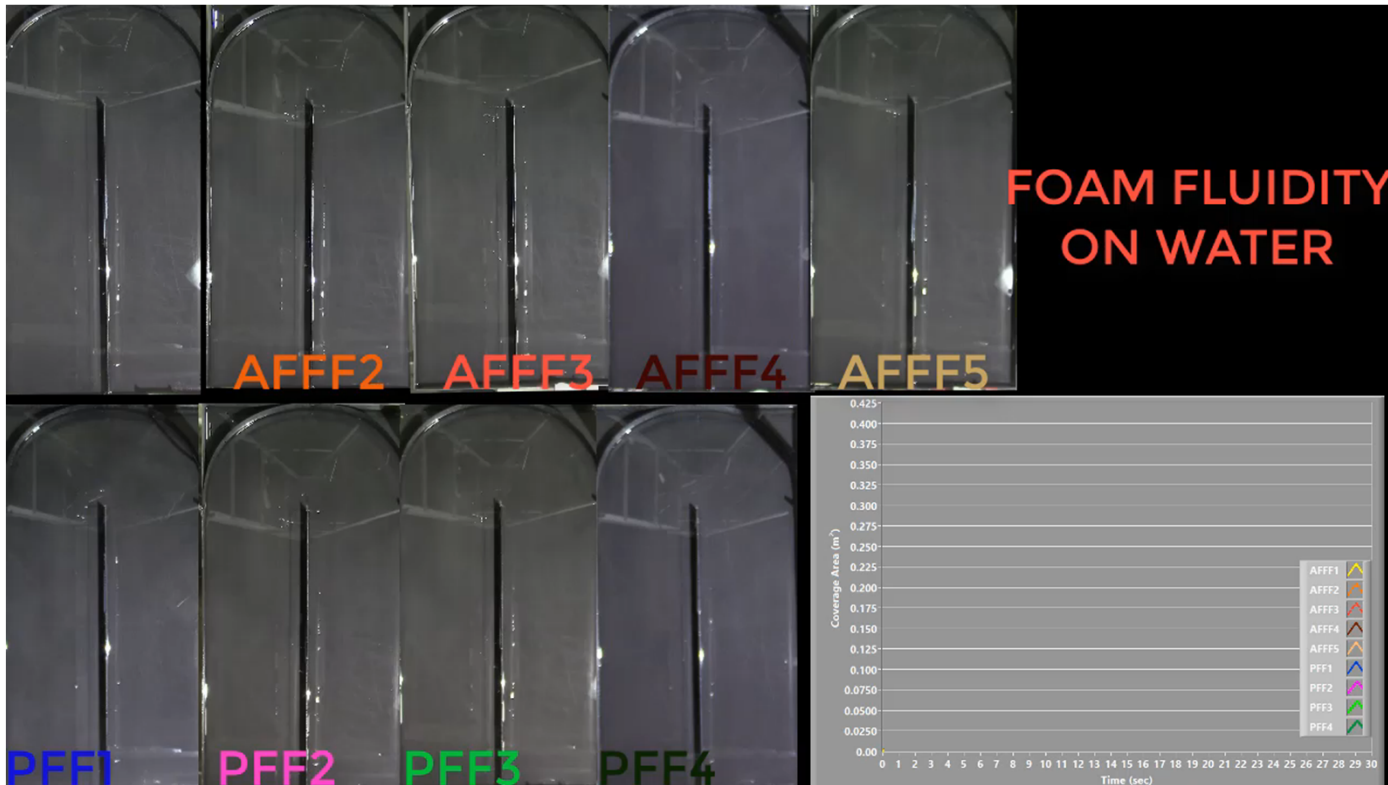

- AFFF are consistent
- PFF generally more sluggish at start
- All foams achieve comparable final spread area

FLUIDITY RESULTS

- Spread of foam on water surface
 - Coverage velocity early in test distinguishes foams
 - $V_{2.5s} > 0.04 \text{ m}^2/\text{s}$; $V_{5.0s} > 0.035 \text{ m}^2/\text{s}$
 - AFFF spreads faster than PFF foams
 - Final coverage areas are about equal for same mass/time

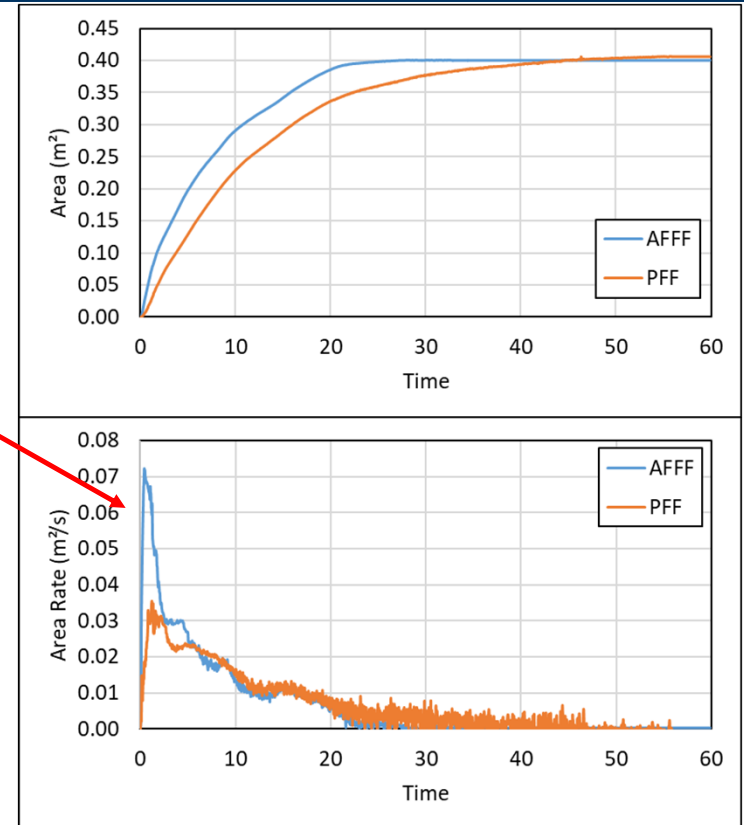
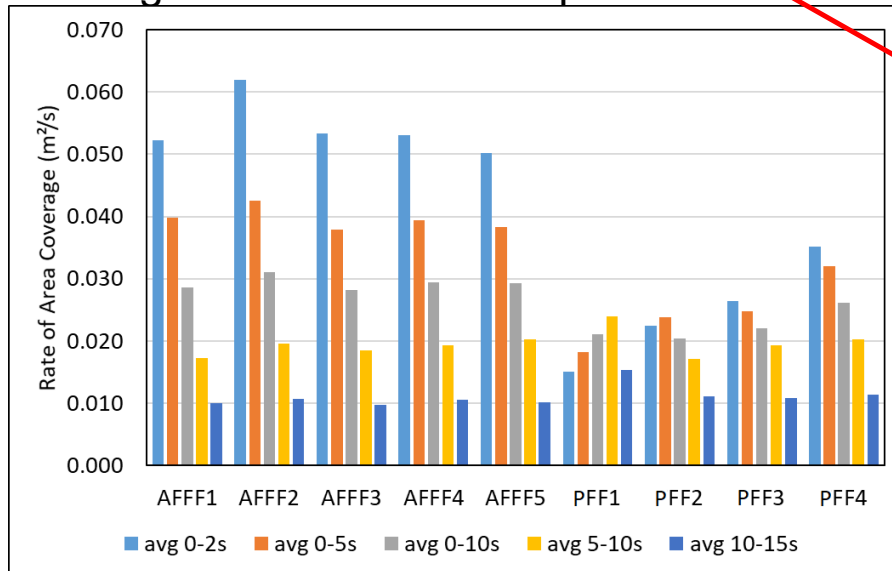

STABILITY

- Radiation source:
 - Conical heater same as used in the cone calorimeter bench-scale fire test.
 - Capable of producing a uniform irradiance over a 4 inch (10 cm) square region below the heater.
- Fuel/foam vessel:
 - Clear, so that levels of fuel and foam may be observed.
 - Deep, so that different thicknesses of foam layer may be applied.
 - Fused quartz vessel with ~3-1/8 inch (8 cm) inside diameter and 4-3/4 inch (12 cm) outside height.
 - Positioned 1 inch (2.5 cm) below the cone heater.
- Scale:
 - High accuracy scale positioned under the heater. Measure the mass of fuel and foam in the vessel over time.
- Video:
 - Image analysis used to differentiate foam drainage from evaporation.

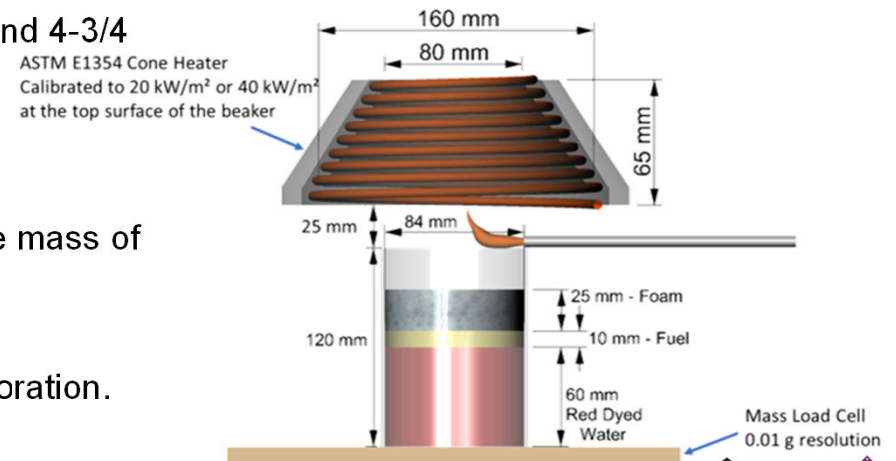
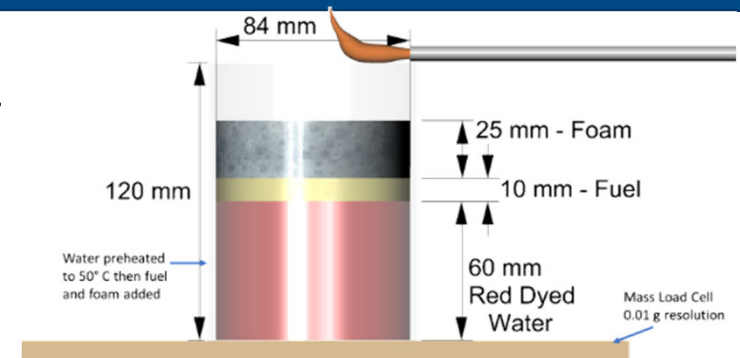

STABILITY

- Fuel is suspended over dyed water.
- Red dye is detected by the image processing algorithm.
- Interface between fuel and red water raises over time as foam drains through the fuel.
- Thickness of fuel layer stays relatively constant while the foam layer is present.
- As the foam layer decomposes, fuel vapors escape through the foam and are ignited by a pilot flame.
- Rate of mass drainage determined by image analysis; rate of evaporation determined by scale measurement and conservation of mass.

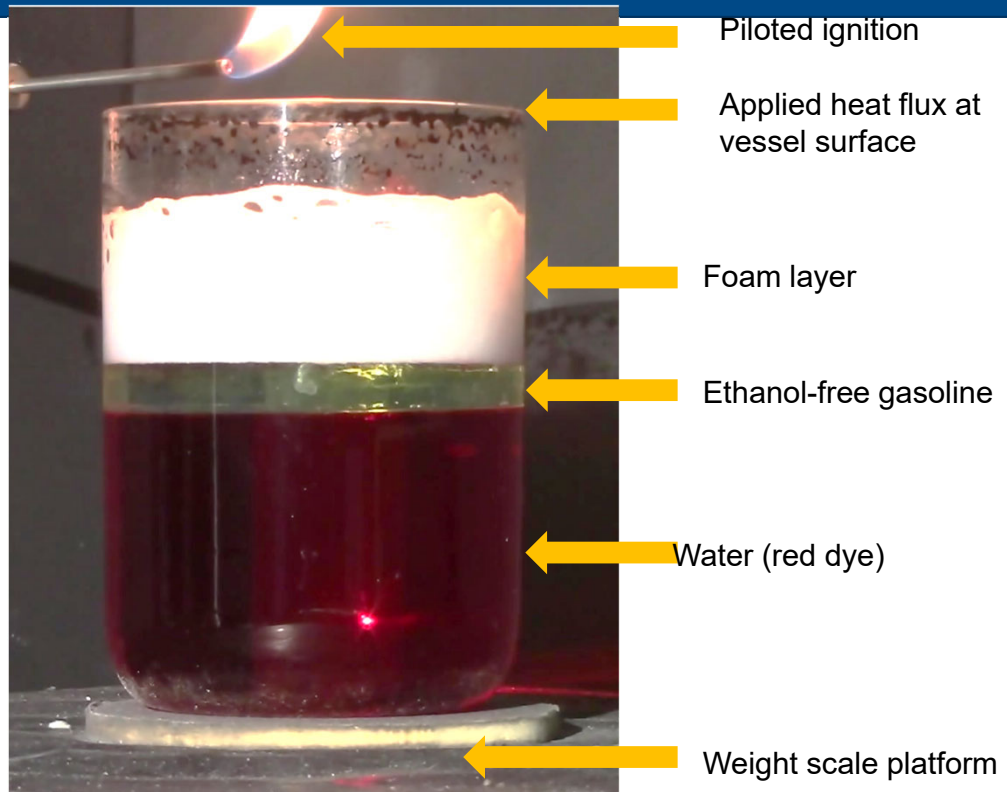

0 kW/m² - Stability – On Hot Fuel

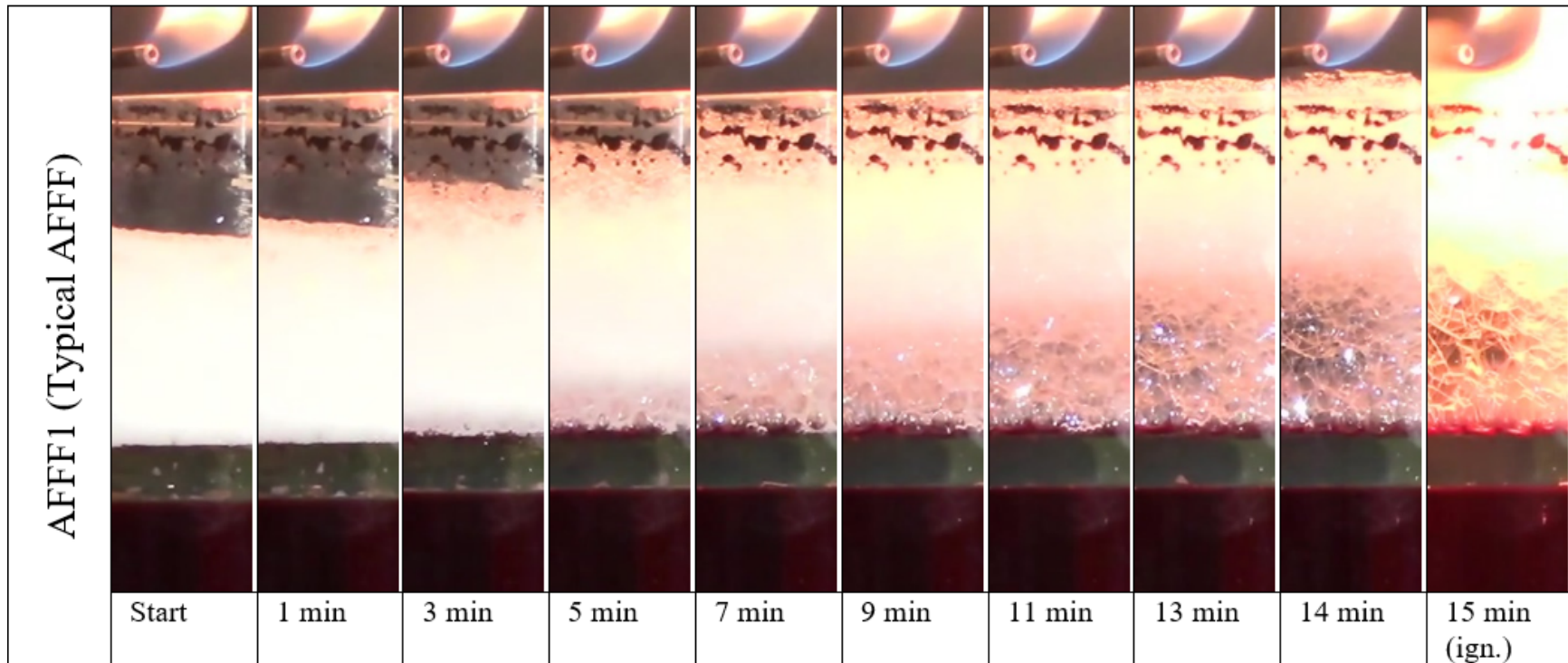

0 kW/m² - Stability – On Hot Fuel

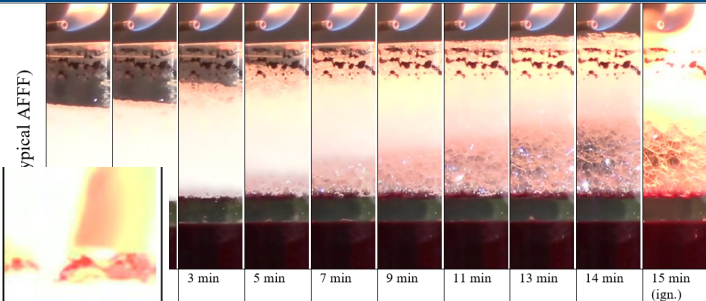
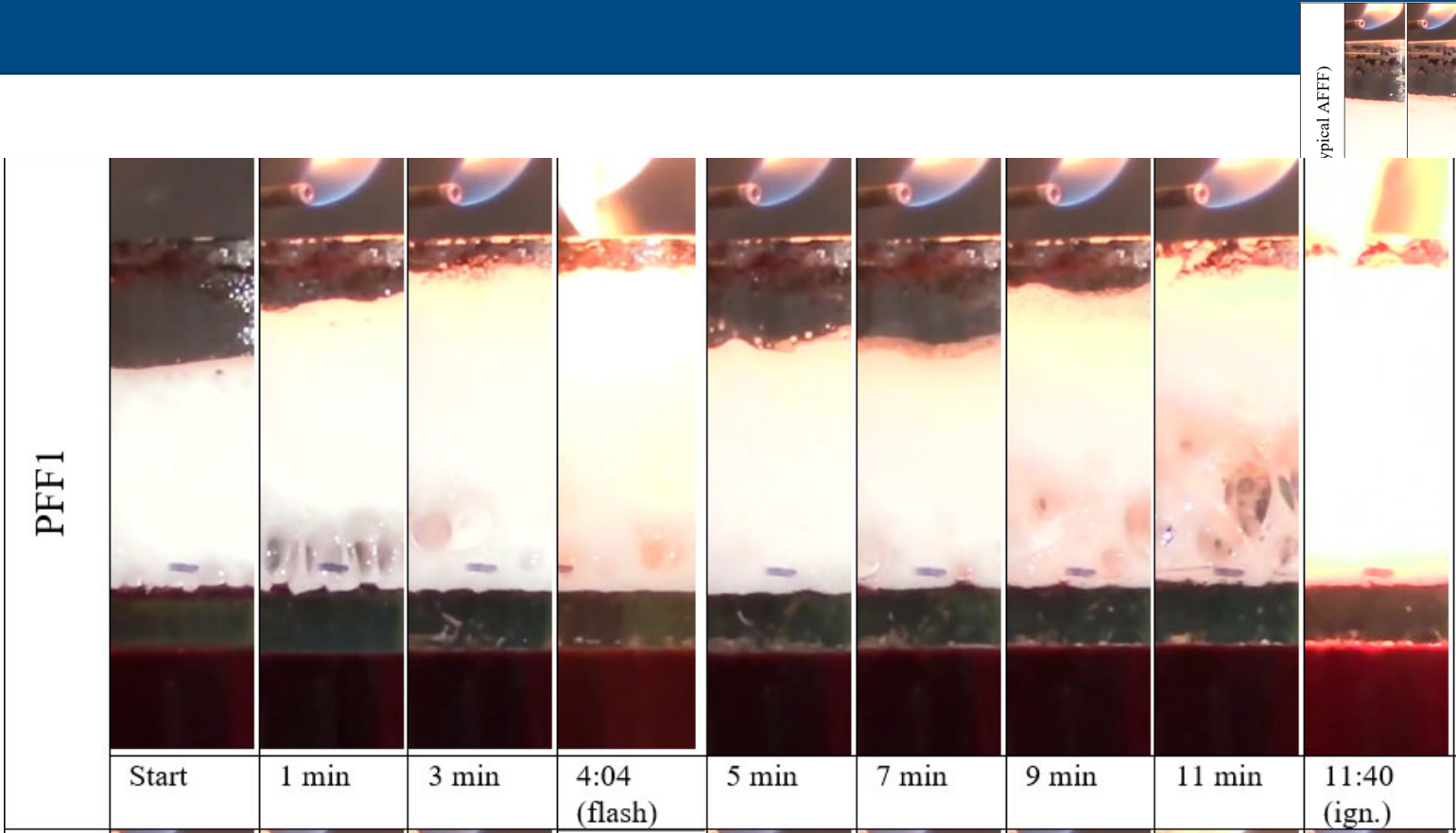

0 kW/m² - Stability – On Hot Fuel

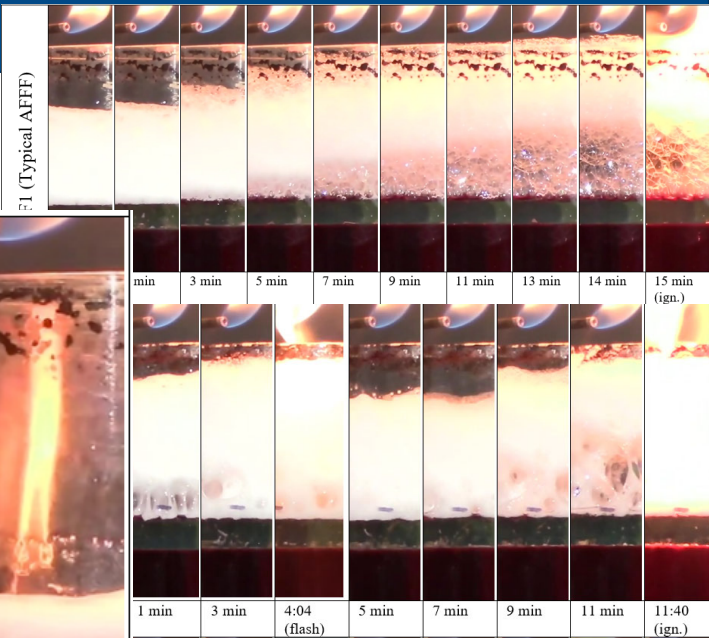
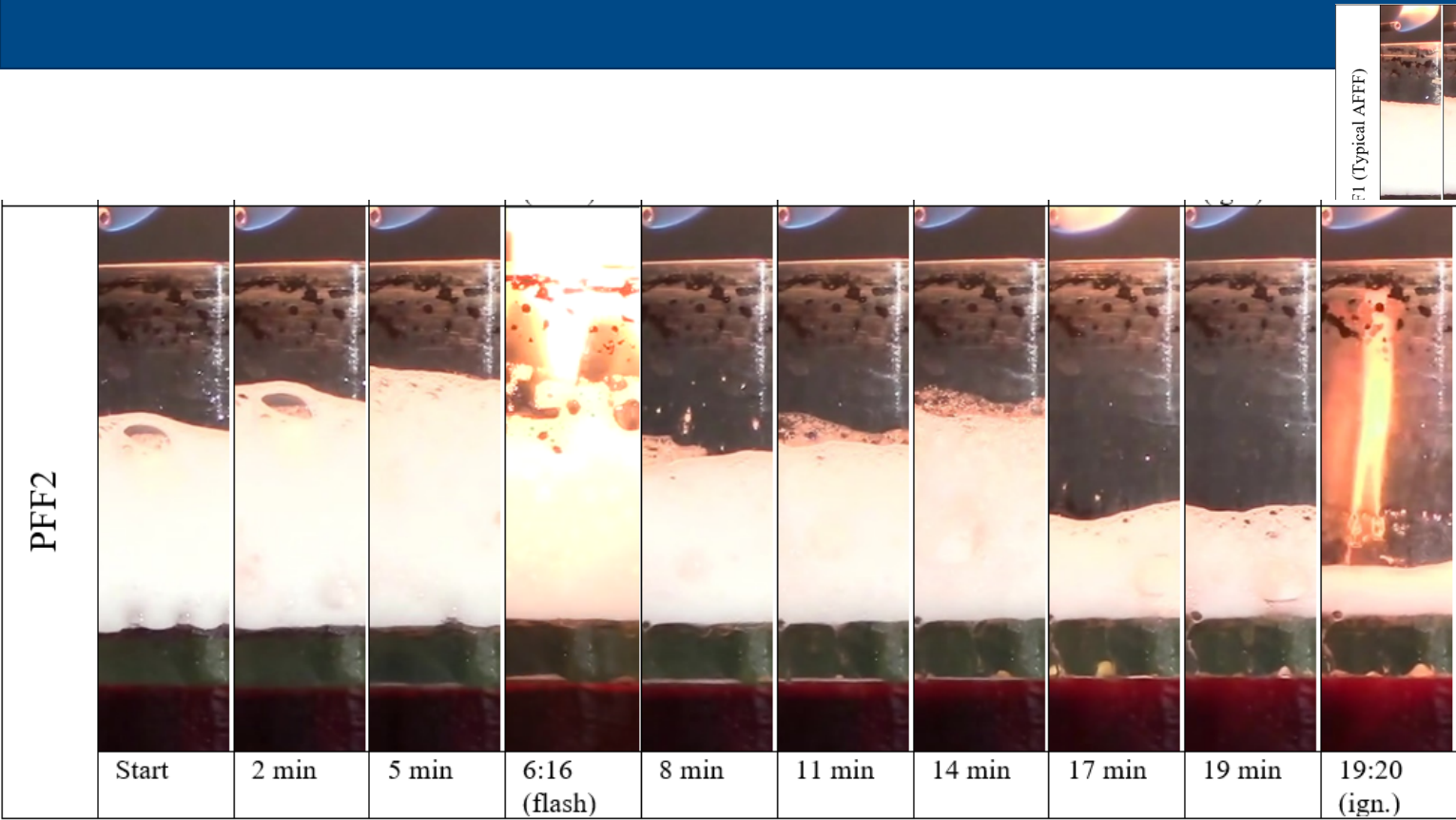

0 kW/m² - Stability – On Hot Fuel



PFF3										
	Start	2:36 (flash)	5 min	8 min	12 min	16 min	20 min	24 min	25 min	25:20 (ign.)

3 min	5 min	7 min	9 min	11 min	13 min	14 min	15 min (ign.)

4:04 (flash)	5 min	7 min	9 min	11 min	11:40 (ign.)

6:16 (flash)	8 min	11 min	14 min	17 min	19 min	19:20 (ign.)

0 kW/m² - Stability – On Hot Fuel

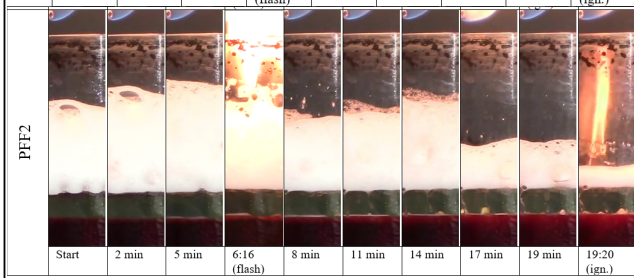
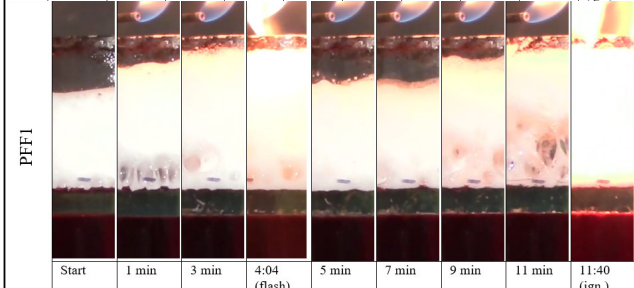
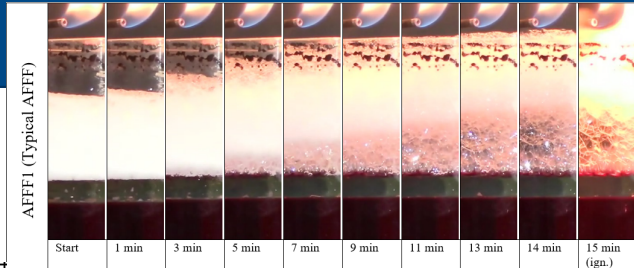
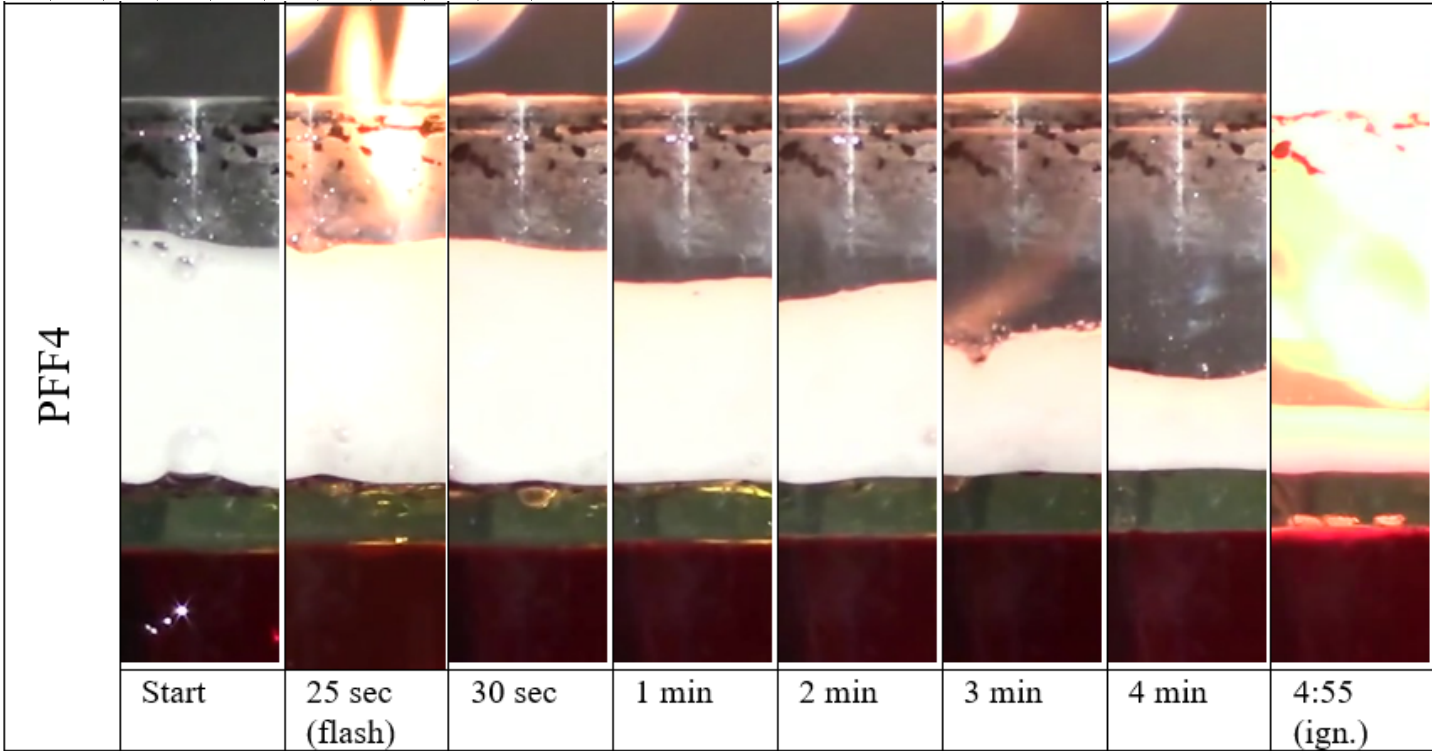
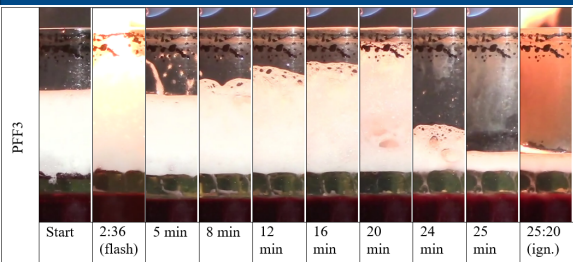

TIME TO FLASH IGNITION

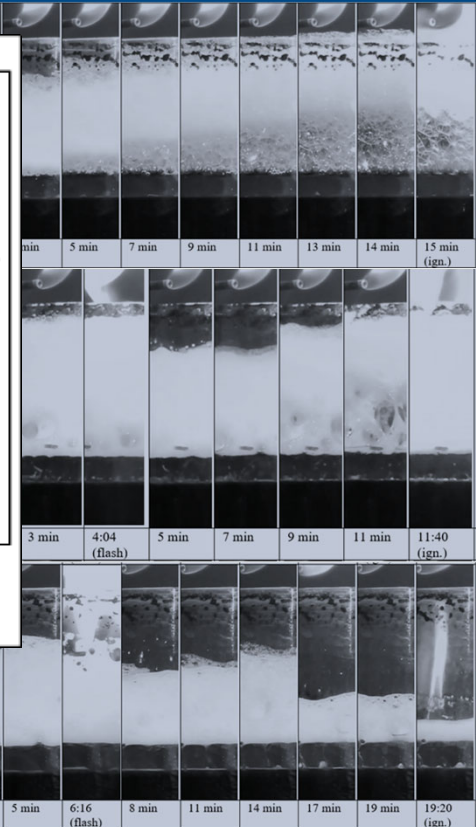
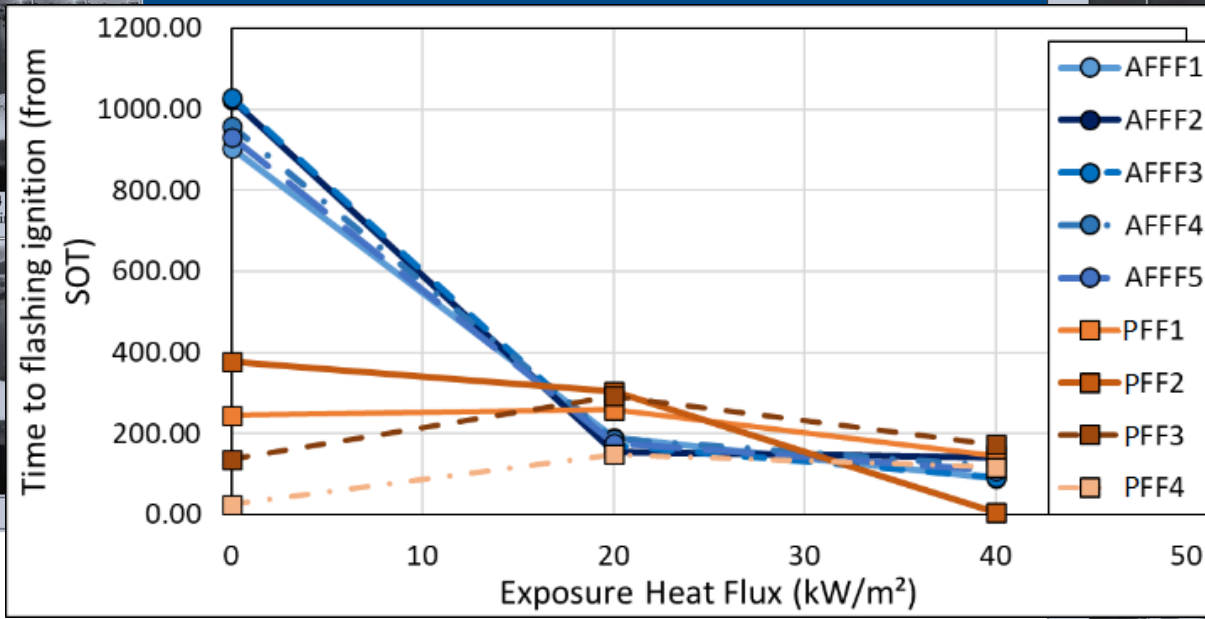
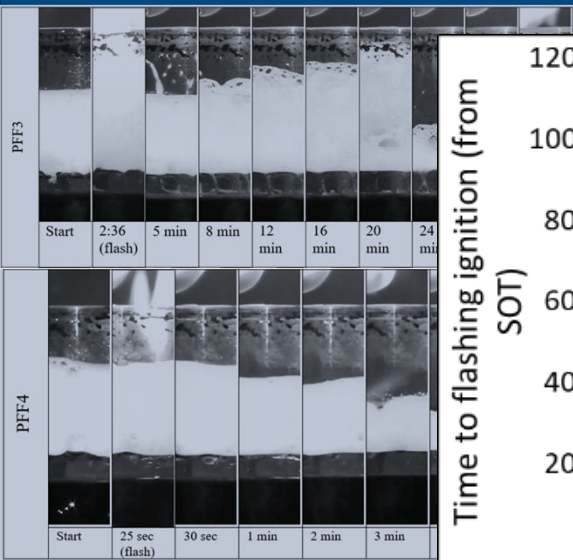

- AFFF do not flash
- Flash ignition at 0 kW/m² over heated fuel seems to be best indicator of performance
 - $t_{ig,flash} > 400$ s to pass / near pass of MilSpec
- FF4 (worst performer) shows shortest flash and sustained ignition times

FOAM DRAINAGE THROUGH FUEL

- Mass drained out of foam, cools fuel
 - All AFFFs similar, PFF have significant increase with increase in heat flux
 - More mass drained in AFFF compared with FF at all heat fluxes at over 30 s, 60 s, and 180 s of test
 - Measured by video analysis algorithm – depth of water layer below fuel

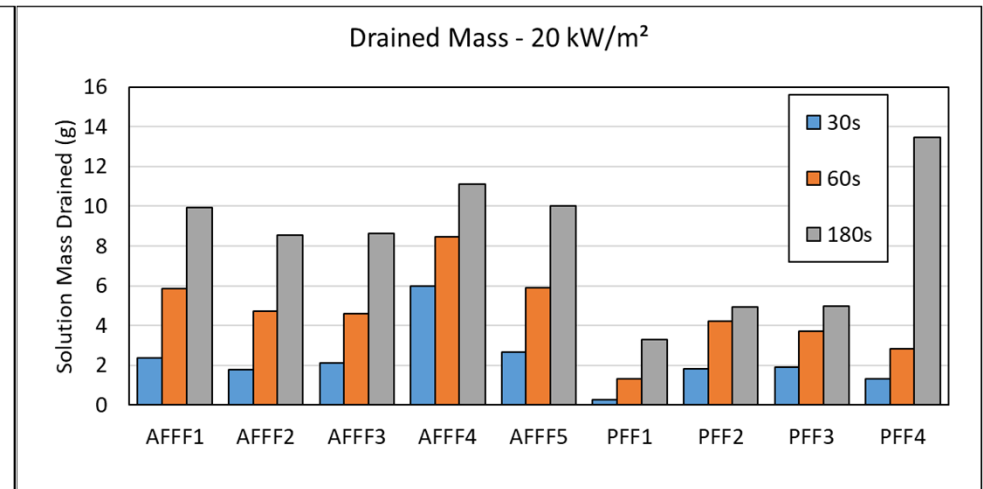
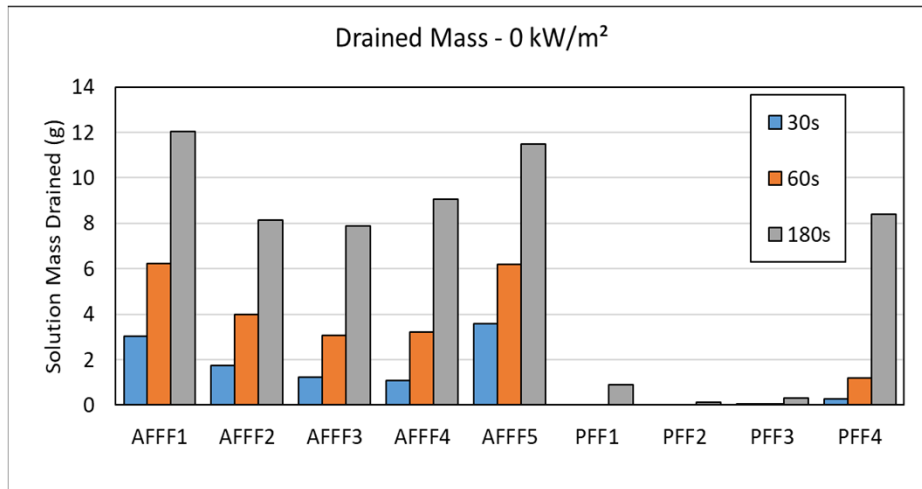

SUPPRESSION AND BURNBACK

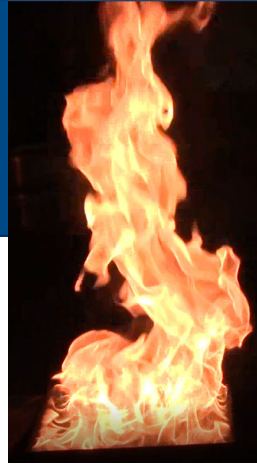

~100 kW free burn
0.6-0.9 m (2-3 ft) flames

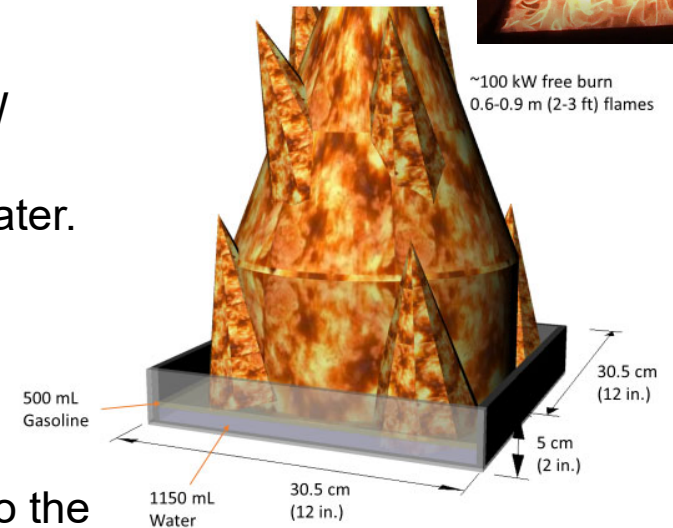

- Fire pan:
 - Fire pan size of 1 ft (0.30 m) sufficiently large to generate turbulent pool fire.
 - The largest size that can be handled for bench-scale testing.
 - Flame height around 3 ft (1 m), heat release rate around 100 kW (steady burning).
 - Contains 500 mL fuel (ethanol-free gasoline) over 1000 mL of water.
- Burnback pan:
 - ~3-1/8 inch (8 cm).
 - Contains 50 mL fuel (ethanol-free gasoline).
- Foam application:
 - Foam is sprayed into collection bucket, weighed, and poured into the fire pan.



FOAM APPLICATION

After preburn duration, foam is poured from top of flames into the center of the pan

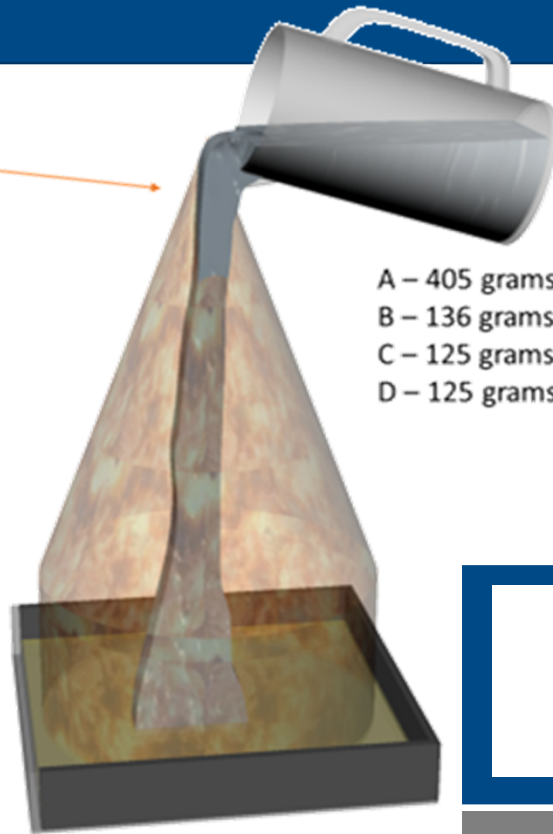

Foam is collected from secondary distribution channel and weighed according to Test Scenario

- A – 405 grams
- B – 136 grams
- C – 125 grams
- D – 125 grams

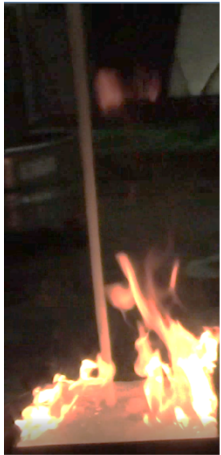

EVALUATION CRITERIA

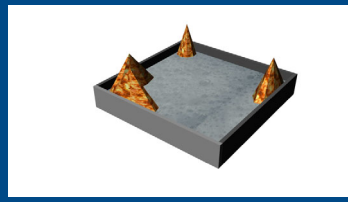
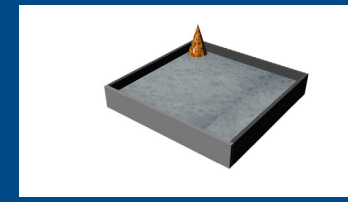
		
Control	Suppression	Extinguished

BURNBACK

Burnback Pan

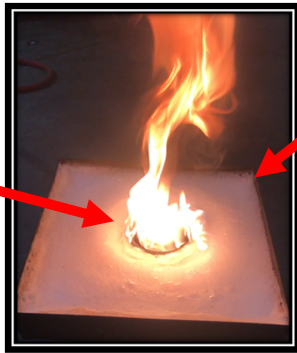

Fuel Pan

8.5 cm (3.3 in.) diameter by 3.9 cm (1.5 in.) deep steel pan

15 mL of gasoline

Ignited and placed into center of the foam

A wire and hooked rod was used to place the burnback pan into the center of the foam

If the foam blanket is too deep, the hook was used to suspend the lip of the pan above the foam blanket to prevent spillage of foam into burnback pan

Burnback pan removed after 5 minutes
If flames extinguished pan was returned and removed again after 7.5 minutes

Sustained burning on the fuel without burnback pan

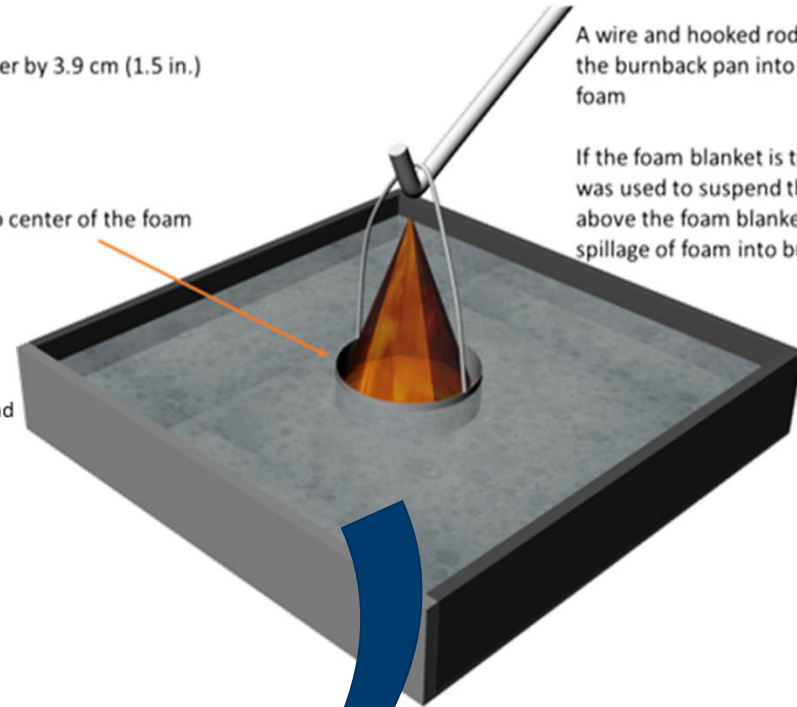
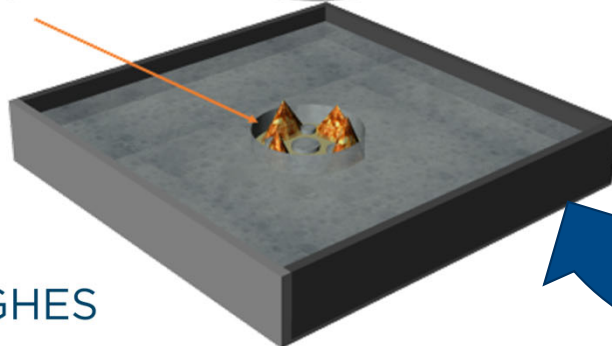

25% BURNBACK



- All shapes equal to 25% of pan area burnback

TEST BASIS AND METHOD

Test method:

- Ignite the fuel and pre-burn for a set time, then apply foam based on application density in MIL SPEC tests and measure the time to extinguishment.
- After a set time, place the burnback pan into the center of the fuel pan, and ignite.
- After a set time, remove the burnback pan and measure the time for 25% of the pan area to reignite.

A series of four progressively more severe tests were developed:

Test	Basis	Description
A	MIL 28 ft ² - 90 seconds of 2 gpm foam application (30 s extinguishment, 60 s before burnback).	10 s pre-burn, add all foam based on 90 s duration (405 g), if extinguished burnback test
B	MIL 28 ft ² - 30 seconds of 2 gpm foam to extinguish fire + 60 seconds of 2 gpm foam before burnback.	10 s pre-burn, add foam based on 30 s duration (136 g), if extinguished add foam based on 60 s duration (269 g), burnback test
C	MIL 50 ft ² - 50 seconds of 2 gpm foam to extinguish fire + 40 seconds of 2 gpm foam before burnback.	10 s pre-burn, add foam based on 50 s duration (125 g), if extinguished add foam based on 40 s duration (98 g), burnback test
D	MIL 50 ft ² - 50 seconds of 2 gpm foam to extinguish fire + 40 seconds of 2 gpm foam before burnback.	20 s pre-burn, add foam based on 50 s duration (125 g), if extinguished add foam based on 40 s duration (98 g), burnback test



AFFF SUPPRESSION PERFORMANCE



SUPPRESSION TEST RESULTS

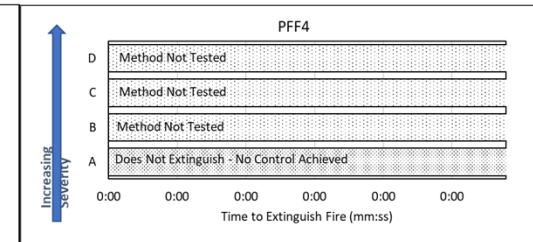
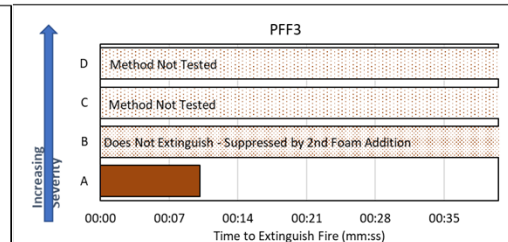
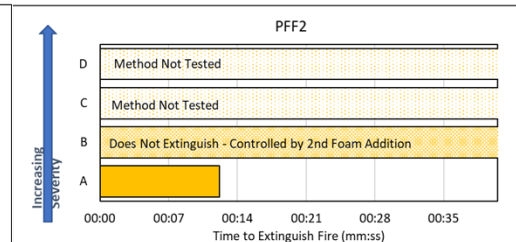
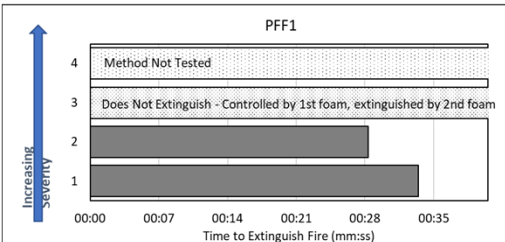
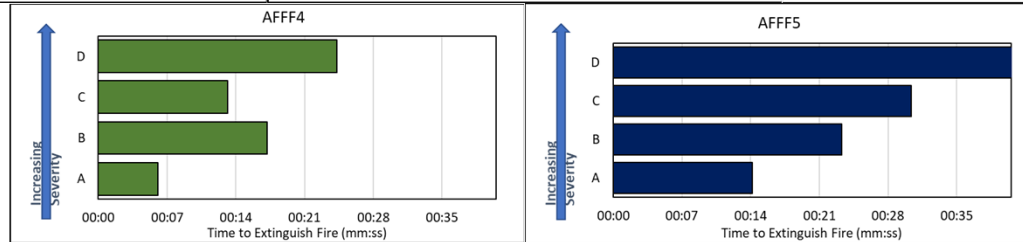
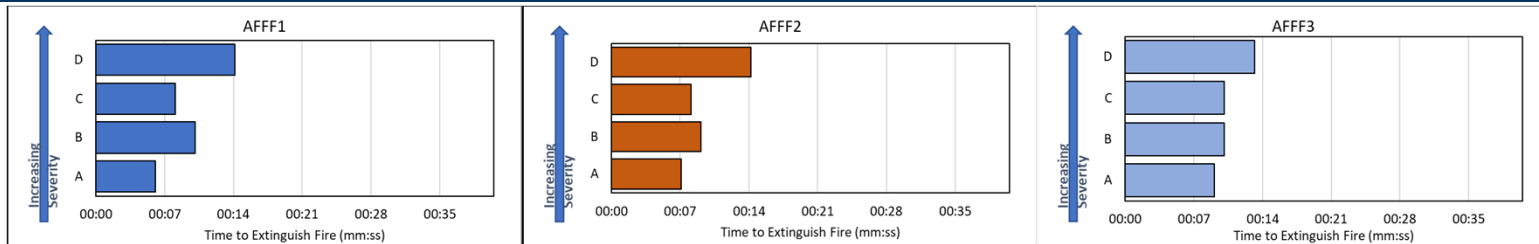

PFF SUPPRESSION PERFORMANCE

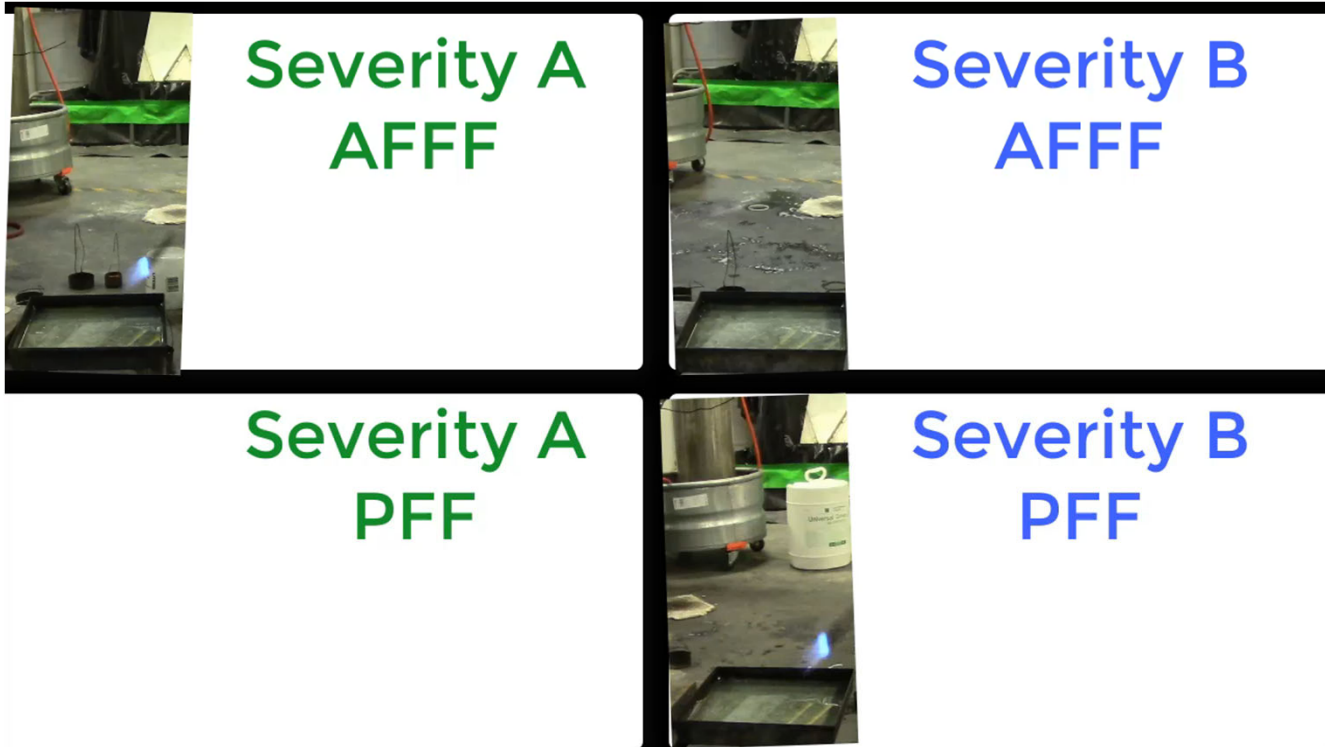

BURNBACK TEST RESULTS

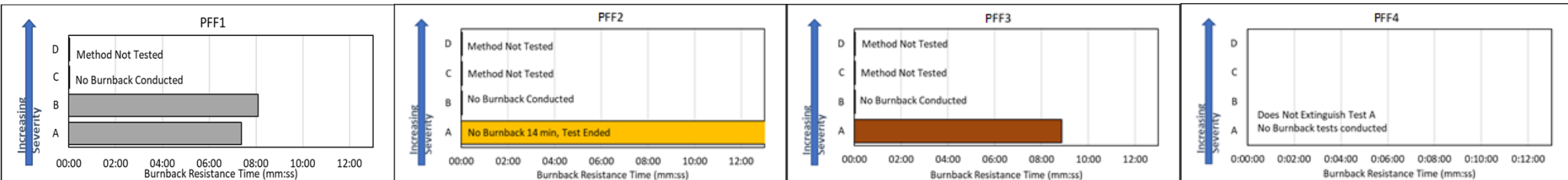
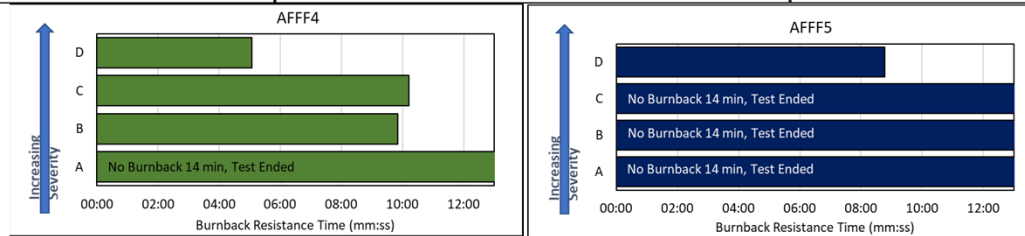
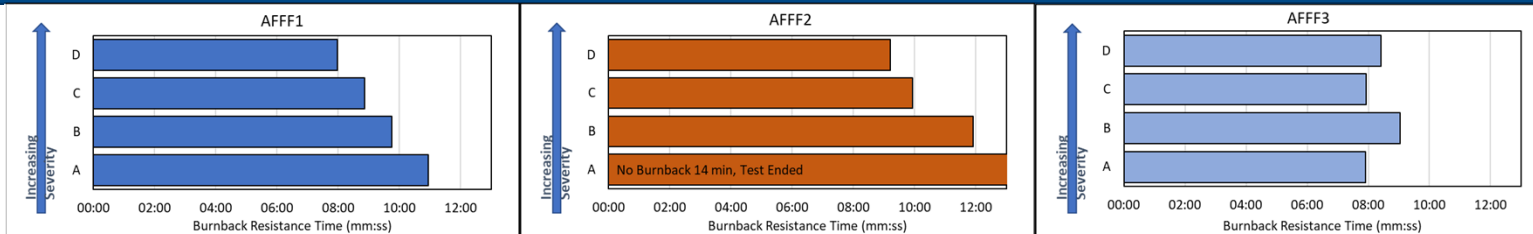

TEST A	Score
NO CONTROL	0
CONTROL - FIRE IN MULTIPLE CORNERS OR AROUND EDGES	1
SUPPRESSION - FIRE NEARLY EXTINGUISHED BUT REMAINS IN 1 CORNER ONLY	5
EXTINGUISHED > 20 SECONDS	25
EXTINGUISHED <= 20 SECONDS	30
TEST B	Score
TEST NOT CONDUCTED - FAILED PREVIOUS TEST	0
APPLICATION 1 - NO CONTROL	0
APPLICATION 1 - CONTROL - FIRE IN MULTIPLE CORNERS OR AROUND EDGES	2
APPLICATION 1 - SUPPRESSION - FIRE NEARLY EXTINGUISHED BUT REMAINS IN 1 CORNER ONLY	10
APPLICATION 1 - EXTINGUISHED > 20 SECONDS	50
APPLICATION 1 - EXTINGUISHED <=20 SECONDS	60
APPLICATION 2 - NO CONTROL	0
APPLICATION 2 - CONTROL - FIRE IN MULTIPLE CORNERS OR AROUND EDGES	2
APPLICATION 2 - SUPPRESSION - FIRE NEARLY EXTINGUISHED BUT REMAINS IN 1 CORNER	10
APPLICATION 2 - EXTINGUISHED	50
TEST C	Score
TEST NOT CONDUCTED - FAILED PREVIOUS TEST	0
APPLICATION 1 - NO CONTROL	0
APPLICATION 1 - CONTROL - FIRE IN MULTIPLE CORNERS OR AROUND EDGES	2
APPLICATION 1 - SUPPRESSION - FIRE NEARLY EXTINGUISHED BUT REMAINS IN 1 CORNER ONLY	10
APPLICATION 1 - EXTINGUISHED > 30 SECONDS	50
APPLICATION 1 - EXTINGUISHED <=30 SECONDS	60
APPLICATION 2 - NO CONTROL	0
APPLICATION 2 - CONTROL - FIRE IN MULTIPLE CORNERS OR AROUND EDGES	2
APPLICATION 2 - SUPPRESSION - FIRE NEARLY EXTINGUISHED BUT REMAINS IN 1 CORNER ONLY	10
APPLICATION 2 - EXTINGUISHED	50
TEST D	Score
TEST NOT CONDUCTED - FAILED PREVIOUS TEST	0
APPLICATION 1 - NO CONTROL	0
APPLICATION 1 - CONTROL - FIRE IN MULTIPLE CORNERS OR AROUND EDGES	2
APPLICATION 1 - SUPPRESSION - FIRE NEARLY EXTINGUISHED BUT REMAINS IN 1 CORNER ONLY	10
APPLICATION 1 - EXTINGUISHED > 30 SECONDS	50
APPLICATION 1 - EXTINGUISHED <=30 SECONDS	60
APPLICATION 2 - NO CONTROL	0
APPLICATION 2 - CONTROL - FIRE IN MULTIPLE CORNERS OR AROUND EDGES	2
APPLICATION 2 - SUPPRESSION - FIRE NEARLY EXTINGUISHED BUT REMAINS IN 1 CORNER ONLY	10
APPLICATION 2 - EXTINGUISHED	50

CORRELATION OF SUPPRESSION RESULTS

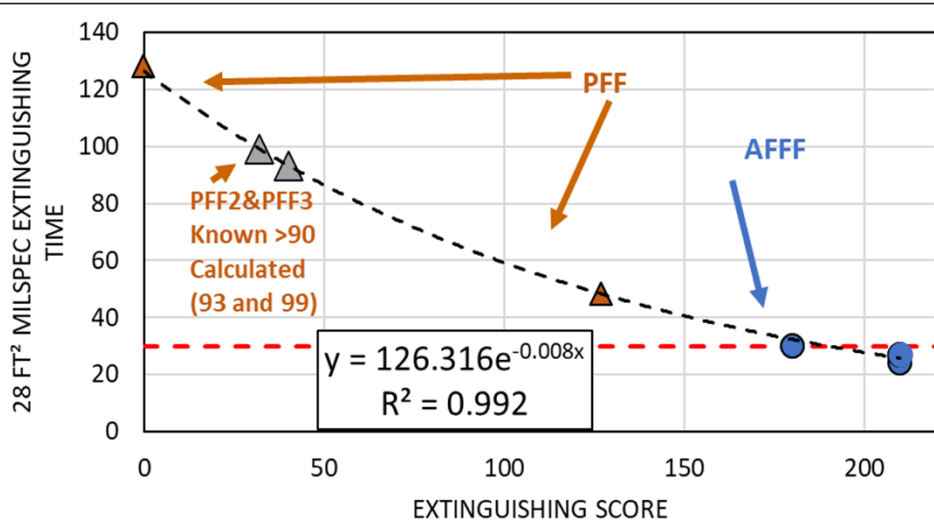

Scoring method shows good ability to predict MIL-SPEC extinguishing time

TEST A		Score
NO CONTROL		0
CONTROL - FIRE IN MULTIPLE CORNERS OR AROUND EDGES		1
SUPPRESSION - FIRE NEARLY EXTINGUISHED BUT REMAINS IN 1 CORNER ONLY		5
EXTINGUISHED > 20 SECONDS		25
EXTINGUISHED <= 20 SECONDS		30
TEST B		Score
TEST NOT CONDUCTED - FAILED PREVIOUS TEST		0
APPLICATION 1 - NO CONTROL		0
APPLICATION 1 - CONTROL - FIRE IN MULTIPLE CORNERS OR AROUND EDGES		2
APPLICATION 1 - SUPPRESSION - FIRE NEARLY EXTINGUISHED BUT REMAINS IN 1 CORNER ONLY		10
APPLICATION 1 - EXTINGUISHED > 20 SECONDS		50
APPLICATION 1 - EXTINGUISHED <=20 SECONDS		60
APPLICATION 2 - NO CONTROL		0
APPLICATION 2 - CONTROL - FIRE IN MULTIPLE CORNERS OR AROUND EDGES		2
APPLICATION 2 - SUPPRESSION - FIRE NEARLY EXTINGUISHED BUT REMAINS IN 1 CORNER ONLY		10
APPLICATION 2 - EXTINGUISHED		50
TEST C		Score
TEST NOT CONDUCTED - FAILED PREVIOUS TEST		0
APPLICATION 1 - NO CONTROL		0
APPLICATION 1 - CONTROL - FIRE IN MULTIPLE CORNERS OR AROUND EDGES		2
APPLICATION 1 - SUPPRESSION - FIRE NEARLY EXTINGUISHED BUT REMAINS IN 1 CORNER ONLY		10
APPLICATION 1 - EXTINGUISHED > 30 SECONDS		50
APPLICATION 1 - EXTINGUISHED <=30 SECONDS		60
APPLICATION 2 - NO CONTROL		0
APPLICATION 2 - CONTROL - FIRE IN MULTIPLE CORNERS OR AROUND EDGES		2
APPLICATION 2 - SUPPRESSION - FIRE NEARLY EXTINGUISHED BUT REMAINS IN 1 CORNER ONLY		10
APPLICATION 2 - EXTINGUISHED		50
TEST D		Score
TEST NOT CONDUCTED - FAILED PREVIOUS TEST		0
APPLICATION 1 - NO CONTROL		0
APPLICATION 1 - CONTROL - FIRE IN MULTIPLE CORNERS OR AROUND EDGES		2
APPLICATION 1 - SUPPRESSION - FIRE NEARLY EXTINGUISHED BUT REMAINS IN 1 CORNER ONLY		10
APPLICATION 1 - EXTINGUISHED > 30 SECONDS		50
APPLICATION 1 - EXTINGUISHED <=30 SECONDS		60
APPLICATION 2 - NO CONTROL		0
APPLICATION 2 - CONTROL - FIRE IN MULTIPLE CORNERS OR AROUND EDGES		2
APPLICATION 2 - SUPPRESSION - FIRE NEARLY EXTINGUISHED BUT REMAINS IN 1 CORNER ONLY		10
APPLICATION 2 - EXTINGUISHED		50

CORRELATION AND ANALYSIS

- Numerous metrics evaluated for each test
 - Rate of mass drainage, evaporation of fuel
 - Video analysis algorithms developed
 - Machine learning analysis used to correlate to MIL-SPEC performance
- Strongest correlations from:
 - Occurrence / Time of flash ignition on heated fuel (tigflash_0)
 - Mass of foam drained in 30 seconds on heated fuel (mdrn30_0)
 - Mass of foam drained in 60 seconds on heated fuel (mdrn60_0_)
 - Foam fluidity velocity in the first 5 seconds

Description	Variable	Analysis Thresholds
Flash Ignition, 0 kW/m ² (s)	tigflash_0	400
Mass drained after 30 s, 0 kW/m ² (g)	mdrn30_0	1.1
Mass drained after 60 s, 0 kW/m ² (g)	mdrn60_0	3.0
Foam Velocity (Area Covered per Time), 0 – 5.0 s (m ² /s)	V0to5	0.035

INCONSISTANCIES IN CORRELATION

- In several cases the trends for AFFF and PFF actual reverse
- For example, high drainage in AFFF indicates good performance, but increased drainage in PFF may correlate to worse performance
- Same for rate of fluid coverage, increased spreading in PFF correlate to worse MIL-SPEC extinguishing time

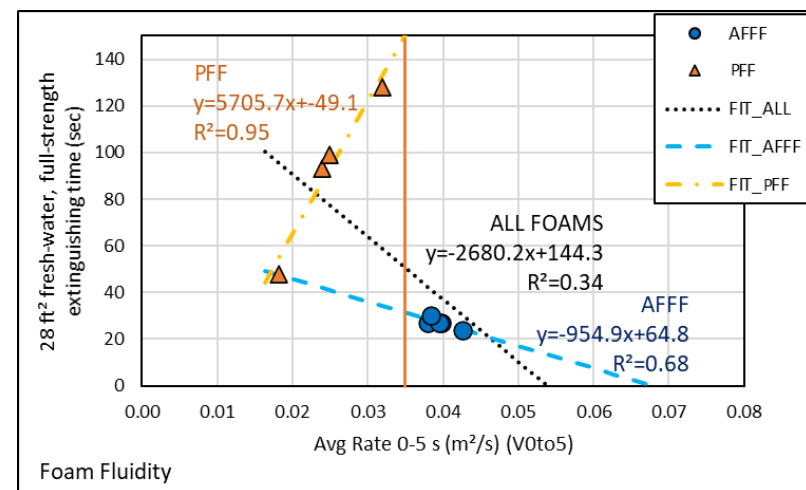
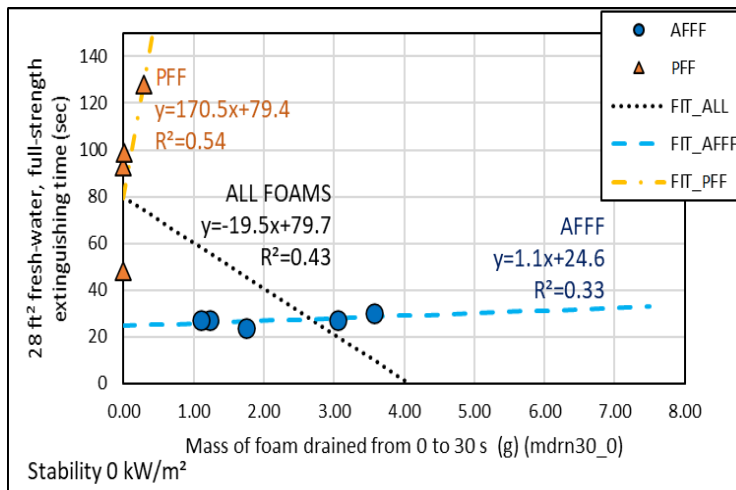

LIMITATIONS

- Full suite of tests is time consuming and expensive
 - Staff training
 - Instrumentation
 - Video analysis algorithm development
- Limited correlation of fluidity and stability results
 - Qualified AFFF and commercially available PFF tested only
 - Lower quality foams or experimental batches may show greater distinction
 - Tests intended to ID MIL-SPEC capable foams, these tests may not be needed
- Use of 2 gpm MIL-SPEC nozzle is still an issue

Conclusions

- Most PFF appear to have difficulty meeting suppression time, not burnback
- Bench-scale pan fire suppression and burn-back test
 - Series of tests with increasing difficulty
 - Good test for ranking performance and identifying whether foam might pass MIL-SPEC or if still a needs further development
 - Does ID parameters to improve to achieve performance
- Stability test
 - Test with no heat (0 kW/m²) → best data to distinguish foams
 - 0 kW/m² mdrn60s > 3.0 g, tig,flash > 400 s
 - Test with 20 kW/m² also provided distinguishing mass drained metric to assess foam performance
 - 20 kW/m² mdrn60s > 4.5 g
- Fluidity test
 - Spread velocity early in test distinguishes foams
 - $V_{2.5s} > 0.04 \text{ m}^2/\text{s}$; $V_{5.0s} > 0.035 \text{ m}^2/\text{s}$
 - Test has more uncertainty and difficult to perform
- Full set of tests – 0.045 gal (0.17 L) of concentrate, only a few milliliters to run S/BB only



OUTCOME

- 2021 SERDP AFFF Challenge
- <https://www.serdp-estcp.org/News-and-Events/Blog/2021-SERDP-AFFF-Challenge>
- https://www.youtube.com/watch?v=9S2XEpmXMJw&ab_channel=SERDPandESTCP
- 1 ft² pan extinguishing challenge



TEAM

- Dr. Brian Lattimer – Virginia Tech
- Jerry Back, Matt DiDomizio, Brianna Gillespie, Lindsay Huffert, Michelle Addai – Jensen Hughes
- John Farley, Stanley Karwoski – NRL

BURNING QUESTIONS?

