

Naval Facilities Command Pacific



E-TCOM

Expeditionary Thermal Conversion of Organic Materials

Presented By

Leroy Harris, Cheyenne Lurvey, & Dorian Espinosa



Agenda

- Introductions
- Current Challenges at On-base Installations
- The Solution: E-TCOM
- E-TCOM System Overview
- Outputs – A Case Study
- Contracting Options
- Questions & Next Steps

Our Team



Alaka'i Services Group Inc.

- Hawaii-based SBA certified 8(a) Disadvantaged Small Business and Native Hawaiian Organization (NHO) owned.
- Focused on providing technical services, research & development (R&D), information technology (IT) & cybersecurity support, business consulting, and subject matter expertise to the DoD.
- Management team has a track record of providing the Navy with optimal solutions for technical and logistical challenges.



Phoenix Carbon LLC

- Hawaii-based Service-Disabled Veteran Owned Business (SDVOB).
- Offers a leading-edge technology for waste reduction & conversion to energy, fuels (SAF), and commercial-grade chemicals from carbon-based solids; capabilities to process contaminated soils as a remediation solution.
- Phoenix Carbon technology specialized in the development of the Thermal Conversion of Organic Materials (TCOM), a U.S. patented system over 15years.

AIR



WATER



LAND



THE PROBLEM

NAVFAC Pacific – Environmental

*-Compliance, Conservation, & Restoration
- Sustainable Solid Waste Management*

Expeditionary

*-Logistics-over-the-shore systems
-Expeditionary IT Systems*

Asset Management

-Facilities Integrated Logistics Support

Design & Construction

-Specialized technical services

■ HIGH EXPENSES

- Tires and plastics are shipped off island.
- Logistical packaging goes to landfills.
- Municipal Solid Waste (MSW) goes to landfills.
- Compliance with Invasive Species Policies
- HAZMAT Spillovers (PFAS, Fuels, Water Contaminates)
- Burn Pits, Sewage, etc.

■ CARBON FOOTPRINT

- Transportation of waste increases Green House Gases (GHG).
- Landfills becoming over capacity.
- Carbon emissions.
- Need to sequester Green House Gases (GHGs)
- Need to reduce Carbon Footprint

■ CLEAN ENERGY

- Need to support the Navy's Great Green Fleet through producing Clean Diesel and Sustainable Aviation Fuel (SAF).
- Reduce conditions that led to PACT Act victims
- Need solutions for clean processes to convert waste to clean energy.

Expeditionary - Thermal Conversion of Organic Materials

Proven Innovation of Combined Technologies

Flash Carbonization

Gasification

Pyrolysis

Pressurization

Catalysts



Patent Holder



An ALTERNATIVE to INCINERATION and LANDFILLS

20-Foot Containerized Configuration



Processor & Canister

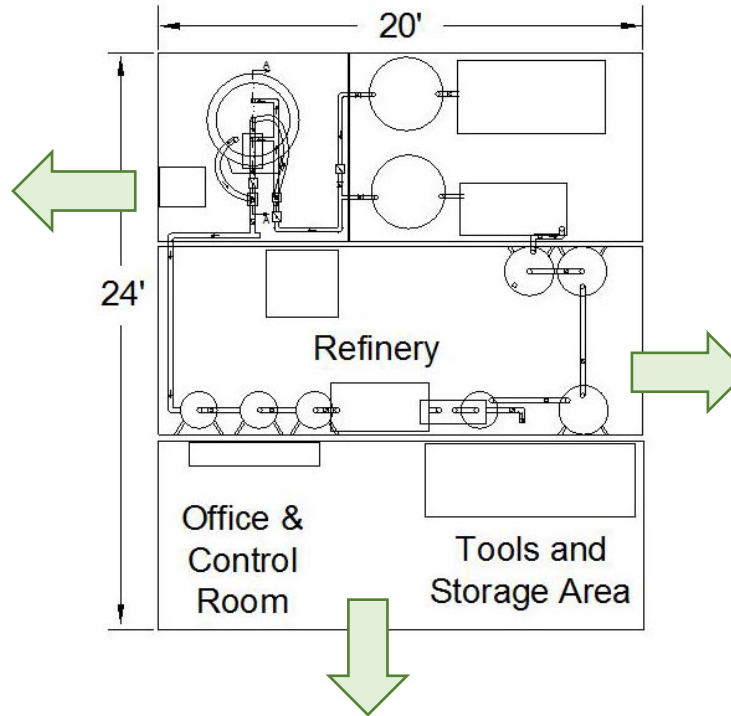

Refinery



Portable Office

Waste Streams for Processing

Tires



Plastics



Municipal



Construction



Green



Agricultural



Forest



Medical



Wastewater Sludge



Process Flow of Solid Material

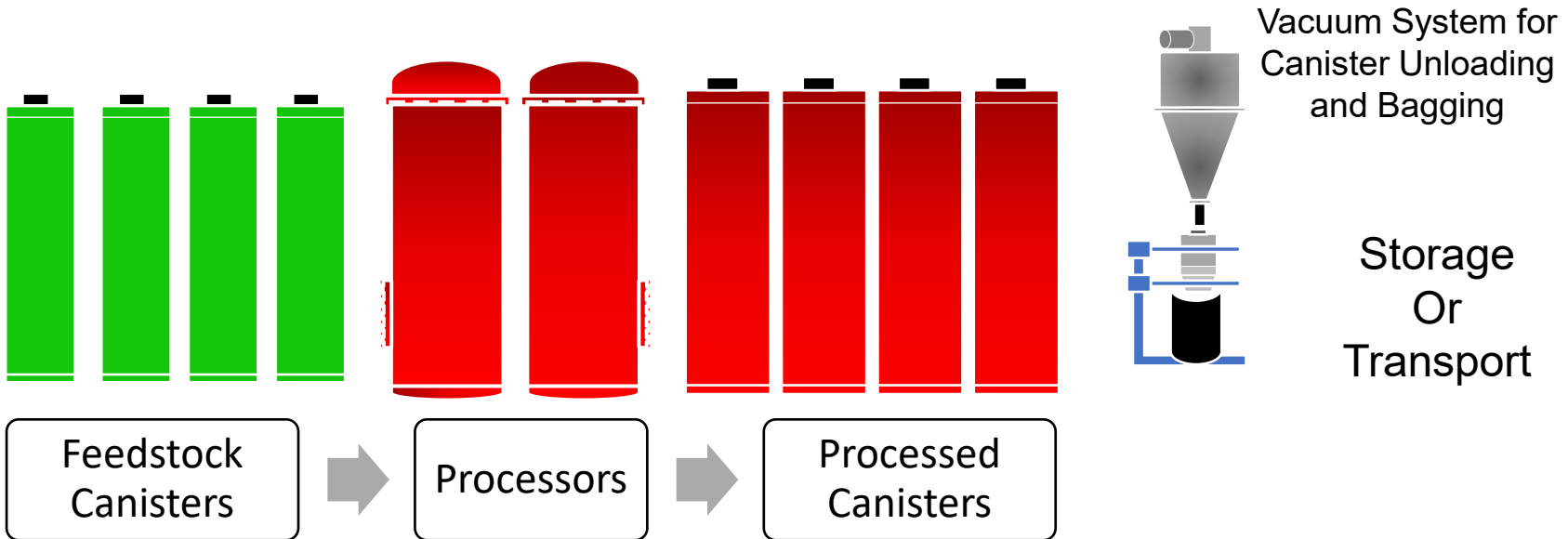
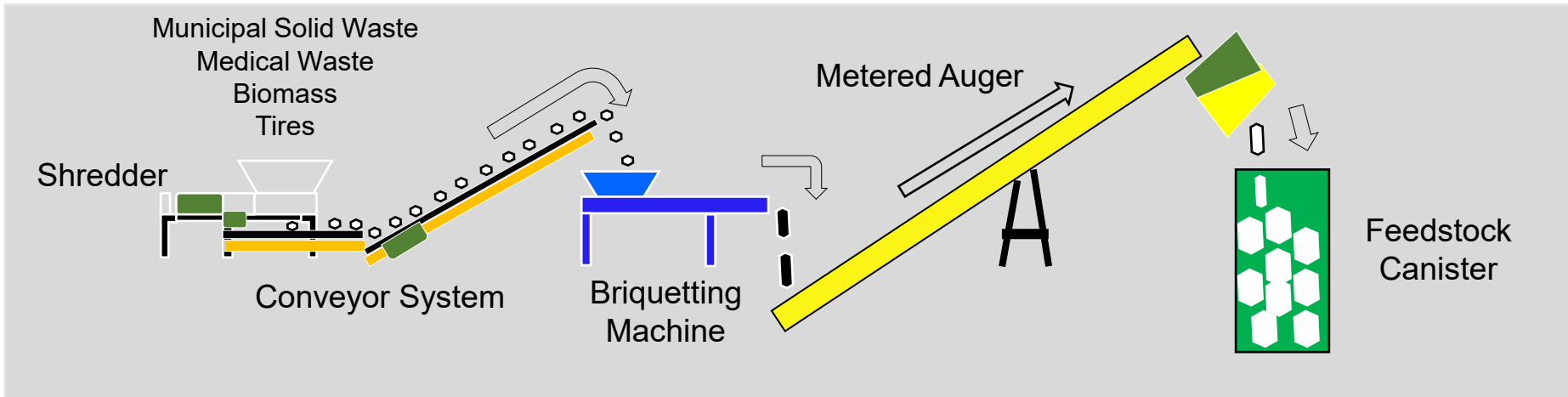

TIRES

Processed Tires Produce:

30% - 45% refined liquid fuel | 30% - 40% solid carbon | 10% - 15% RNG | 10% - 20% metals

E-TCOM Systems

Amount of Processed Materials per hour

Estimated Annual Production

ET1m

70 cubic foot volume

1.5 Tons

5,760 Tons

of Processed Materials

=

527,000 Gallons of Fuel

ET2m

250 cubic foot volume

6 Tons

23,040 Tons

of Processed Materials

=

2,142,720 Gallons of Fuel

Plastics have similar yield results (less the metal products). Wood and carbonaceous products will have higher yields of solid carbon (40-55%) with lower refined liquid fuels (20-35%) with the remaining percentage evolved into Renewable Natural Gas (RNG).

Streamlined Contracting

Leveraging Direct Award & Sole-Source Process

NHO 8(a) Direct Award Benefits:

- Fast Requirements Definition & Direct Award Compliant
- Reduced Acquisition Decision Cycle
- Up to \$100 Million Contract without J&A
- Contract Award Cannot be Protested
- Lowered Administrative Costs
- Best Value Pricing & Services
- Small Business Credit



Ecological Dividends

Environmental Economic

Energy Efficiency
Resource Conservation
Subsidies/Incentives

Social Environmental

Environmental Justice
Stewardship
Local/Global Connections

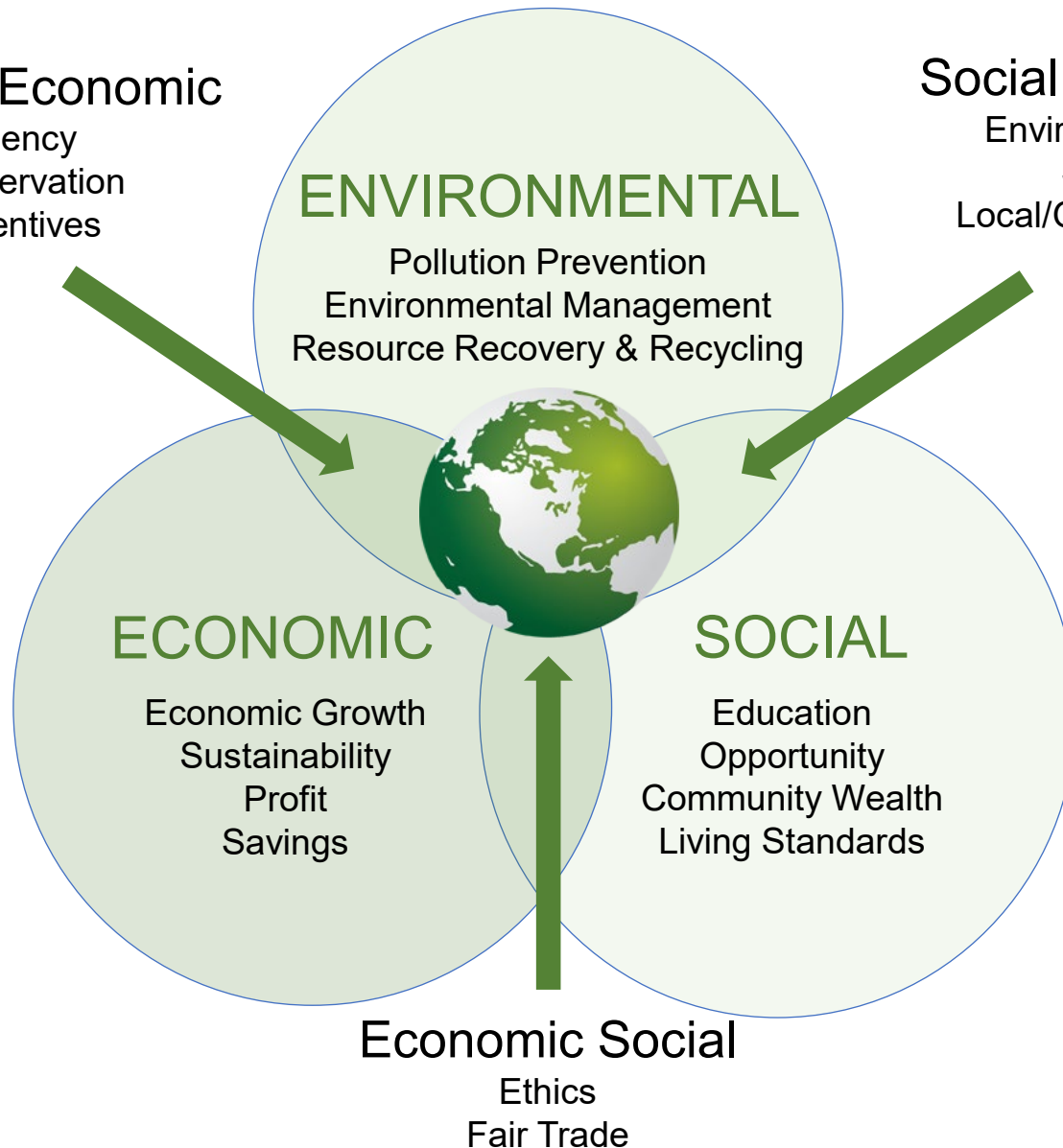

Summary

Navy Deployable Waste-to-Clean Energy E-TCOM Pilot Project

Expeditionary – Thermal Conversion of Organic Materials (E-TCOM)

- Processing consists of:
 - Flash Carbonization
 - Gasification
 - Pyrolysis
 - Pressurization
 - Catalysts



Current Challenges at On-base Installations

- Waste Disposal Expenses
- HAZMAT Disposal Expenses
- Negative contributions to Landfills
- Negative contributions to the Environment
- Limited Waste-to-Energy Solution On-base (Precursor to a Micro Grid)
- Clean Fuels to support the Navy's Great Green Fleet
- Reduce Carbon Footprint On-base
- Need for Public "Good Will" Message about the Navy's positive environmental contributions
- Prevent Spillovers: PFAS, Fuels, Other Contaminates
- Soil Remediation after Spillovers

E-TCOM Solution

- Containerized & Mobile
- 100% Sequester of GHGs
- Scalability to meet the mission

Feedstocks:

Tires, Plastics, Municipal Solid Waste (MSW), HAZMAT, Green Waste, Medical Waste, Construction, Wastewater Sludge, etc.

By-products:

SAF, Diesel, Propane, Electricity, BIOCHAR, Charcoal, Activated Carbon, Carbon Black, etc.

Way Ahead

- **Partner with E-TCOM to Pilot (Environmental Services like NAVFAC; Disposal Services like DLA; Landfill reduction like Guam, etc.)**
- **Purchase E-TCOM**
- **Lease E-TCOM**
- **Turnkey Solution – Equipment & Staffing**
- **Acquisition Strategy:** Native Hawaiian Organization (NHO) (8a) Certified up to **\$100M Direct Award Noncompete**

Thank You



CONTRACTS POC:

Dorian Espinosa

Dorian.Espinosa@alakaiservicesinc.com

(808) 330-6808

PRIMARY POC:

Leroy Harris

LeroyHarris@phoenix-carbon.com

TECHNICAL POC:

Michael Lurvey

Michael@phoenix-carbon.com

Website: www.phoenix-carbon.com