

REPORT DOCUMENTATION PAGE*Form Approved
OMB No. 0704-0188*

The public reporting burden for this collection of information is estimated to average 1 hour per response, including the time for reviewing instructions, searching existing data sources, gathering and maintaining the data needed, and completing and reviewing the collection of information. Send comments regarding this burden estimate or any other aspect of this collection of information, including suggestions for reducing the burden, to Department of Defense, Washington Headquarters Services, Directorate for Information Operations and Reports (0704-0188), 1215 Jefferson Davis Highway, Suite 1204, Arlington, VA 22202-4302. Respondents should be aware that notwithstanding any other provision of law, no person shall be subject to any penalty for failing to comply with a collection of information if it does not display a currently valid OMB control number.

PLEASE DO NOT RETURN YOUR FORM TO THE ABOVE ADDRESS.

1. REPORT DATE (DD-MM-YYYY)		2. REPORT TYPE		3. DATES COVERED (From - To)	
4. TITLE AND SUBTITLE				5a. CONTRACT NUMBER	
				5b. GRANT NUMBER	
				5c. PROGRAM ELEMENT NUMBER	
6. AUTHOR(S)				5d. PROJECT NUMBER	
				5e. TASK NUMBER	
				5f. WORK UNIT NUMBER	
7. PERFORMING ORGANIZATION NAME(S) AND ADDRESS(ES)				8. PERFORMING ORGANIZATION REPORT NUMBER	
9. SPONSORING/MONITORING AGENCY NAME(S) AND ADDRESS(ES)				10. SPONSOR/MONITOR'S ACRONYM(S)	
				11. SPONSOR/MONITOR'S REPORT NUMBER(S)	
12. DISTRIBUTION/AVAILABILITY STATEMENT					
13. SUPPLEMENTARY NOTES					
14. ABSTRACT					
15. SUBJECT TERMS					
16. SECURITY CLASSIFICATION OF:			17. LIMITATION OF ABSTRACT	18. NUMBER OF PAGES	19a. NAME OF RESPONSIBLE PERSON
a. REPORT	b. ABSTRACT	c. THIS PAGE			19b. TELEPHONE NUMBER (Include area code)

91st MORS Symposium

"Analytics as a Force Multiplier"

Army Future Force Structure Analysis

Ms. Adwoa Gyekye

Mr. Curt Hudson

Dr. Suzanne DeLong

The view, opinions, and/or findings contained in this report are those of The MITRE Corporation and should not be construed as an official Government position, policy, or decision, unless designated by other documentation.

Agenda

- Background, Sponsor and Problem Statement
- Methodology
- Scenario Planning and Development
- Mission Threads/Vignettes/Scenarios
- Wargame Units/System and Terrain Characteristics
- Future Force Structure Courses of Action (COA) Measures
- Translating Wargame into Simulation
- Data Elements and Structure
- Project Outcome and Future Work

Background and Sponsor

- Army Futures Command (AFC), Futures and Concepts Center (FCC) Sponsor
- Support to wargaming the Future Study Program (FSP) and the writing of the next Army Operating Concept for 2040

This work is being done directly for a future Army concept and a direct sponsor

- Use of Operational Wargaming System (OWS) with VASSAL game engine
- Extending Wargaming into Simulation for experimentation with Future Army Force Structure

Methodology: Laying the groundwork for Force Structure Analysis

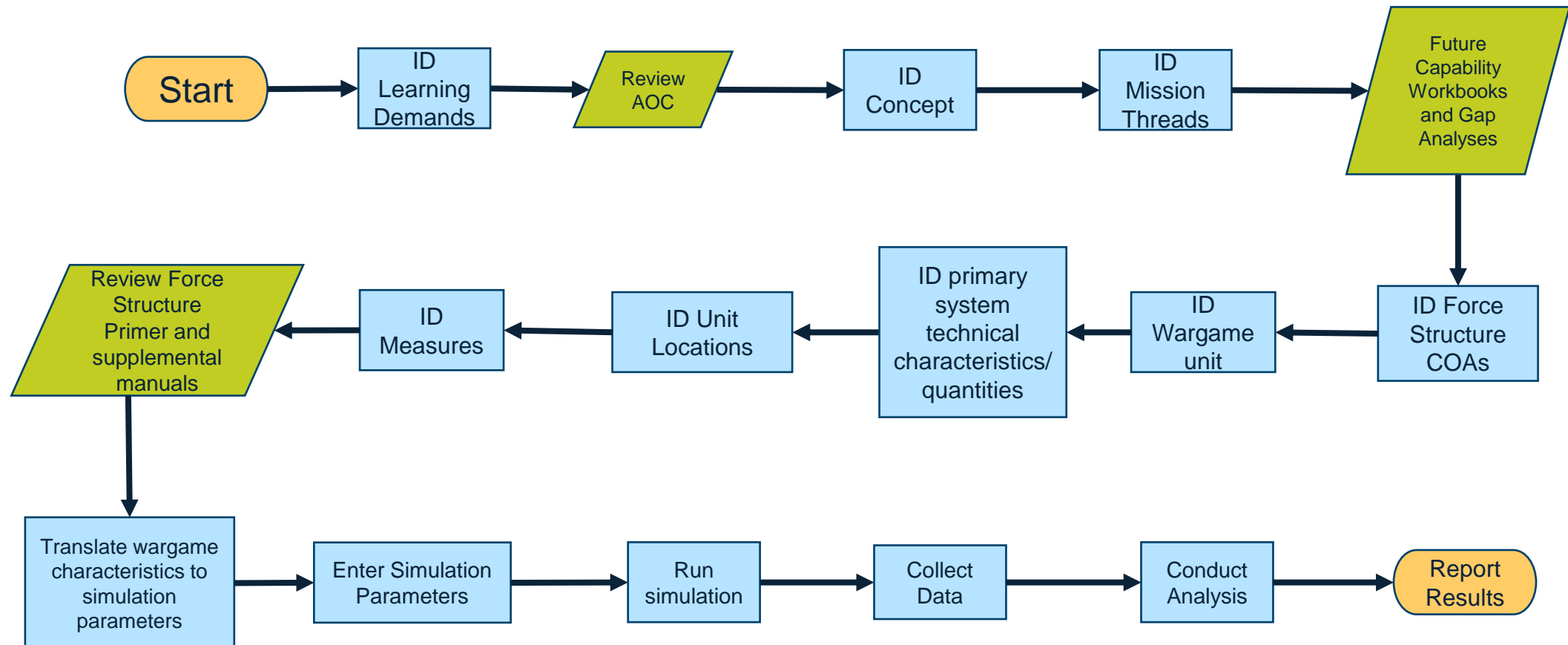

***Proof of concept starts at the Brigade level and progresses to higher echelons**

Military Scenario Planning Framework and Development Process

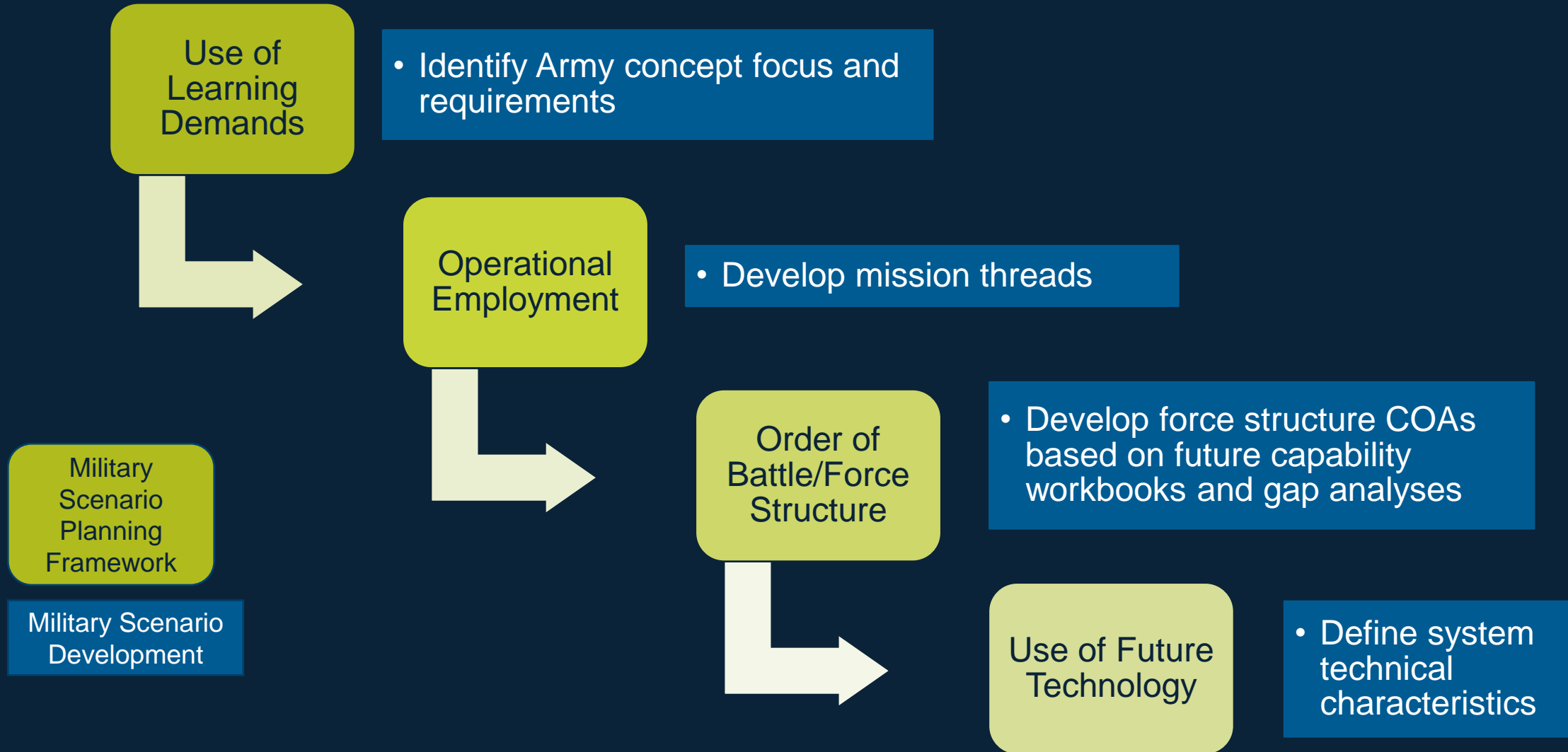

Mission Thread Examples

- Wet gap crossing
- Vertical envelopment
- Defend an APOD

- Use Case = System level
- Mission Thread = System of Systems (SoS) Level
 - A [mission thread](#) is a sequence of end-to-end activities and events presented as a series of steps that accomplish the execution of one or more capabilities that the SoS supports.
- Vignette – includes environmental factors

ID Wargame Units: OWS Unit Representation

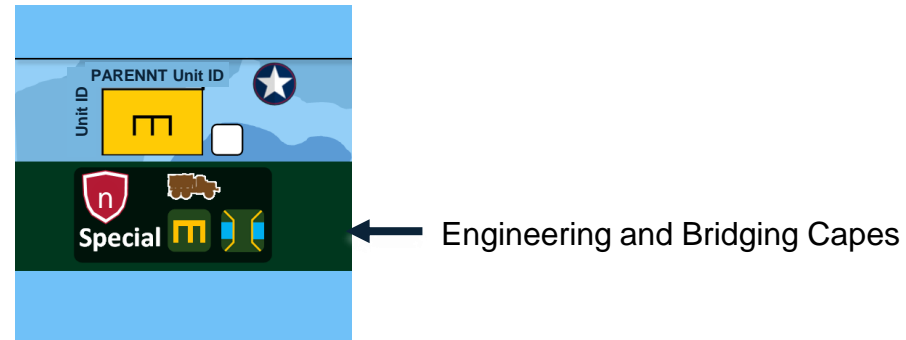
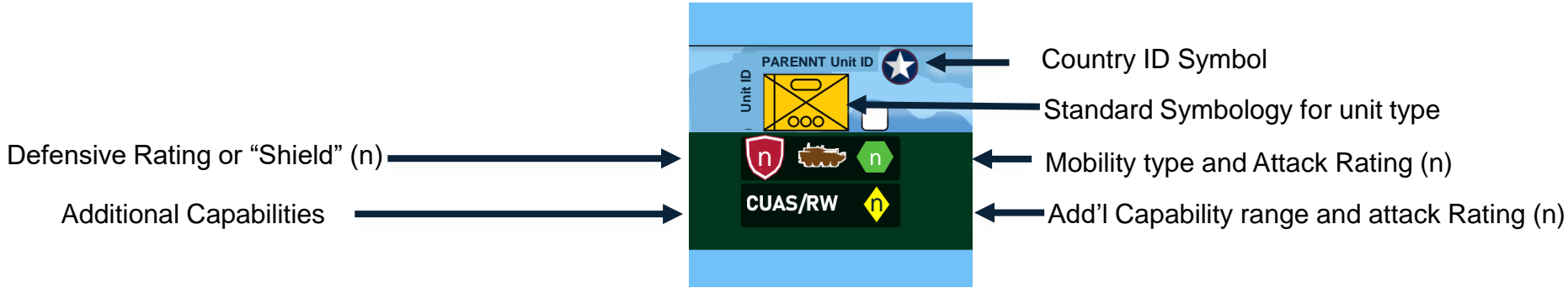

- 1 turn = 24 hours
- Operational Map = 200nm/hex
- Tactical Map = 10 nm/hex
- Global map. Theater maps
- Unit scale Bn to Theater Army
- All domains/WfF

Attack Capabilities and range (land attack only) (m/n)

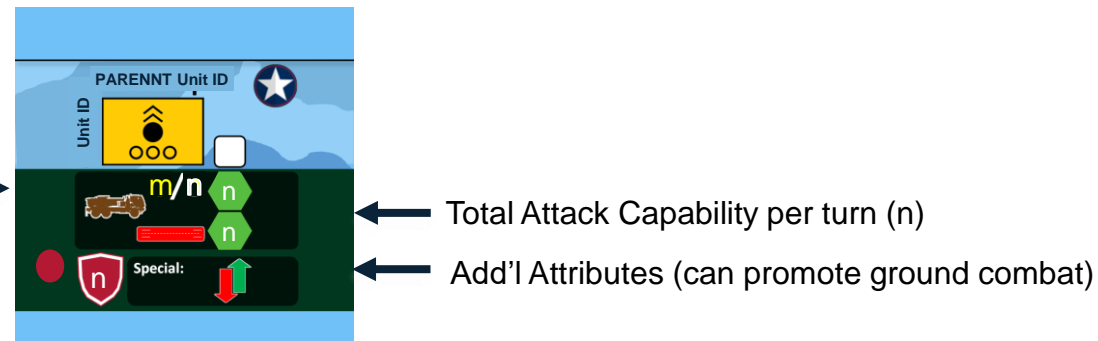

System Technical Characteristics/Behaviors Examples

- Air
- Ground
- Surface
- Weapon (kinetic and non-kinetic)
- Communication
- Countermeasures
- Fire Control
- Munition
- Navigation
- Radar Warning Receiver
- Sensor
- Attack Vehicle
- Cyber
- Command Post (C2)

Terrain Characteristics - Unit Locations

Considerations:

- Area/Hex/Point
- Terrain coordinate system
- Elevation source data and resolution (DTED, HRTE)
- Map scale
- Terrain database formats
- Features (Buildings, roads, vegetation, soil type, etc.)

OWS/Vassal → NGTS:

- World file produced by GIS tool QGIS to edit the source map imagery
- Export as a .PNG file along with the .PGW world file
- Pixel coordinate into Lat/Long translator
- Export file from Vassal to NGTS

Wargame (OWS/Vassal)



Simulation (NGTS)



Sample COA Measures

COA 1 Baseline (Current) Force
 COA 2 (TBD)
 COA 3 (TBD)

Measures	Wet gap crossing	Vertical envelopment	Defend an APOD
	Time for Blue to cross gap	Distance Blue penetrates Red Defenses	Percent of damage to APOD
	Time for Blue to seize objective	Time to start/end envelopment	Time to secure APOD
		# / % of Red stimulated	
		# / % Red entities sensed	
		Time Blue senses Red	
		# / % Red engaged	
		# Blue rounds expended	
		Range at which Red engaged	
		Time Blue system engages	
	# / % Blue entities damaged		
	# / % Blue entities destroyed		
	# / % Red entities damaged		
	# / % Red entities destroyed		

Data Elements and Structure

Description	Command Level/ Unit Type	Defensive rating (Shield)	Primary System	Number of Counters	M1A2/M2	M1126	M109A7	M1283	M1150	IFPC
Unit	HQ (CP)				0	0	0	0	0	0
Unit	Combined Arms		M1A2/M2		0	0	0	0	0	0
Unit	Stryker		M1126		0	0	0	0	0	0
Unit	SP Artillery		M109A7		0	0	0	0	0	0
Unit	Engineer		M1150		0	0	0	0	0	0
Unit	AD		IFPC2		0	0	0	0	0	0

Source: "MCoE SUPPLEMENTAL MANUAL 3-90 FORCE STRUCTURE REFERENCE DATA"

Project Outcome and Future Work

Project Outcome:

- **Insights into Force Structure implications**
- **Instantiation of the interface protocol for OWS wargame and NGTS simulation**
 - Data structure that goes between the wargame and simulation
 - User developed OM (Object Model)

Future Work: Bridge Wargame to Simulation

- Instantiation of the interface protocol for any wargame and any simulation
- This effort will focus on researching methods for migrating the output of a wargame into an appropriate level (entity-based or aggregate) simulation for conducting Monte Carlo-style experiments.

Wargame Alternatives
OWS, COTS, Design your own
Others?

Simulation Alternatives
AFSIM, NGTS, OneSAF, VRForces, WARSIM
Others?

Contacts

Ms. Adwoa Gyekye

Group Leader and Operations Research
MITRE National Security N214
MITRE McLean
Email: agyekye@mitre.org

Dr. Suzanne DeLong

Applied Operations Research Lead
MITRE National Security N213
MITRE Hampton Roads
Email: sdelong@mitre.org

Mr. Curt B. Hudson, Jr.

Mission and Wargaming Systems Engineer Principal
MITRE National Security N151
MITRE Hampton Roads
Email: chudsonjr@mitre.org