

# SEI-CMU Quantum Computing Introduction

**JULY 26, 2023**

SEI Quantum Computing Team



# Document Markings

Copyright 2023 Carnegie Mellon University.

This material is based upon work funded and supported by the Department of Defense under Contract No. FA8702-15-D-0002 with Carnegie Mellon University for the operation of the Software Engineering Institute, a federally funded research and development center.

The view, opinions, and/or findings contained in this material are those of the author(s) and should not be construed as an official Government position, policy, or decision, unless designated by other documentation.

NO WARRANTY. THIS CARNEGIE MELLON UNIVERSITY AND SOFTWARE ENGINEERING INSTITUTE MATERIAL IS FURNISHED ON AN "AS-IS" BASIS. CARNEGIE MELLON UNIVERSITY MAKES NO WARRANTIES OF ANY KIND, EITHER EXPRESSED OR IMPLIED, AS TO ANY MATTER INCLUDING, BUT NOT LIMITED TO, WARRANTY OF FITNESS FOR PURPOSE OR MERCHANTABILITY, EXCLUSIVITY, OR RESULTS OBTAINED FROM USE OF THE MATERIAL. CARNEGIE MELLON UNIVERSITY DOES NOT MAKE ANY WARRANTY OF ANY KIND WITH RESPECT TO FREEDOM FROM PATENT, TRADEMARK, OR COPYRIGHT INFRINGEMENT.

[DISTRIBUTION STATEMENT A] This material has been approved for public release and unlimited distribution. Please see Copyright notice for non-US Government use and distribution.

This material may be reproduced in its entirety, without modification, and freely distributed in written or electronic form without requesting formal permission. Permission is required for any other use. Requests for permission should be directed to the Software Engineering Institute at [permission@sei.cmu.edu](mailto:permission@sei.cmu.edu).

DM23-0752

# Agenda

## Research

- **Quantum Advantage Framework**
- **Quantum Resource Estimation**
- **Quantum Architecture**

## Quantum Landscape and Cyber Protection

- Identification of Key Challenges in Early-Stage Quantum Computing
- Cyber security and IP protection
- Talks and workshops

- Collaboration

Presentation Name

# SEI-CMU Quantum Work

# Quantum Advantage Evaluation Framework (QAEF)

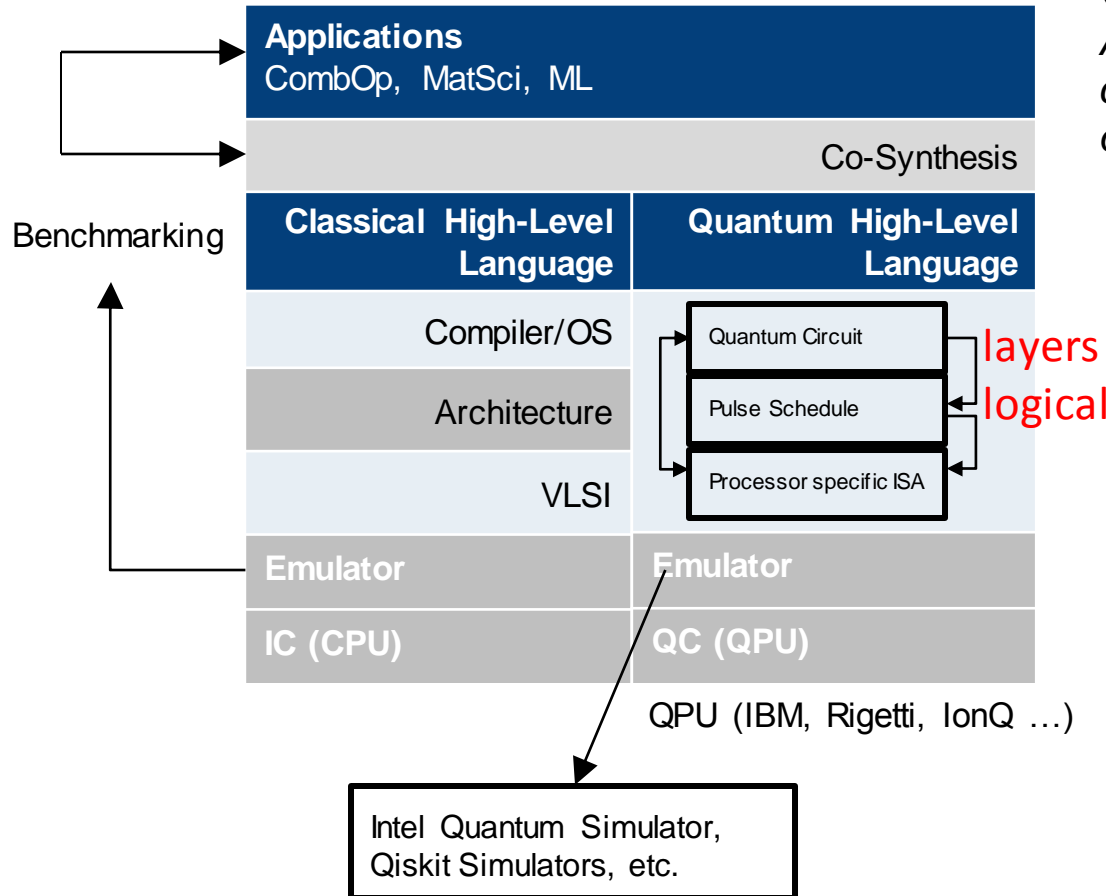

*QAEF compares benchmarks for Applications on both quantum and classical SoTA computing to determine quantum advantage.*

*Identify applications with potential Quantum Advantage in near-term*

*Synthesize Emulation of Classical with Software-Hardware.*

*Universal Gate has emerged at the technology most likely to achieve quantum advantage*

# Quantum Advantage Evaluation Framework

## Problem

When and where can the DoD benefit it from investing in quantum computing technology? To answer this question, we are working with noisy intermediate scale quantum (NISQ) computers, but we're also thinking ahead to fault-tolerant quantum error corrected computation. In particular, we want to determine when and where quantum advantage will exist for the following important DoD applications:

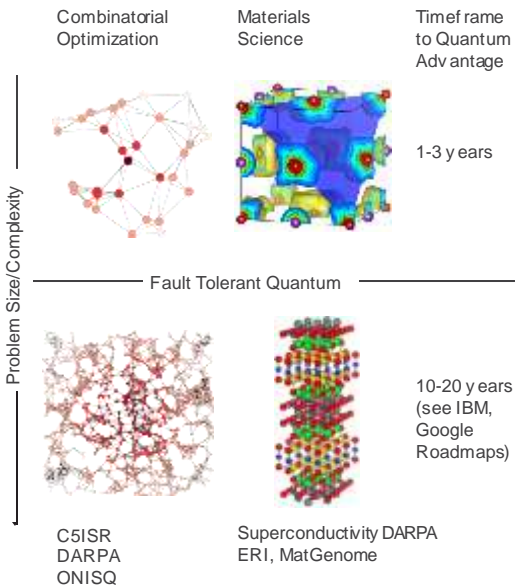

## Framework to evaluate current and projected quantum computing advantage.

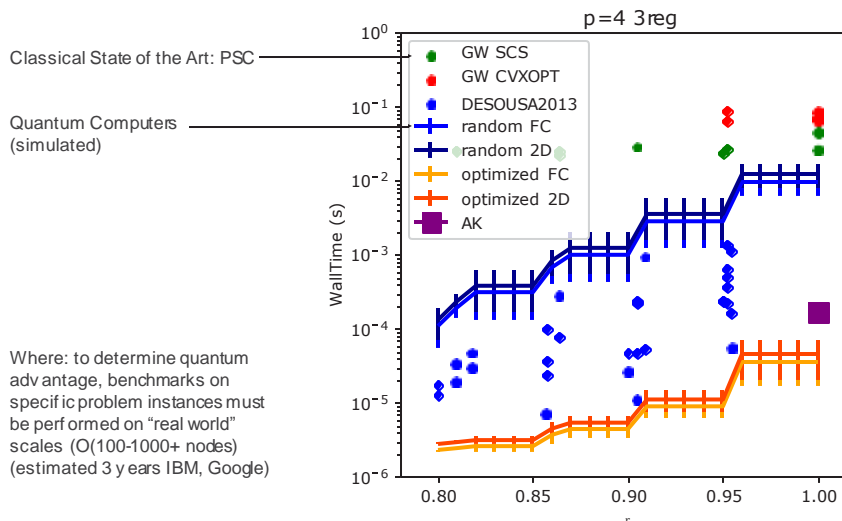
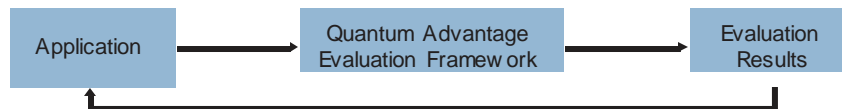

Where: to determine quantum advantage, benchmarks on specific problem instances must be performed on "real world" scales ( $O(100-1000+)$  nodes) (estimated 3 years IBM, Google)

<https://arxiv.org/abs/2006.04631>  
"Assessment of Alternative Objective Functions for Quantum Variational Combinatorial Optimization," M. Jonsson, et al, IEEE QCE Quantum Week 2020

## SEI Collaboration with Carnegie Mellon University

Quantum algorithm performance depends critically on quantum circuit optimization. We are working with CMU ECE Franz Franchetti's group to adapt their well-known classical computing optimization tool, SPIRAL.

### Quantum Circuit Optimization in SPIRAL

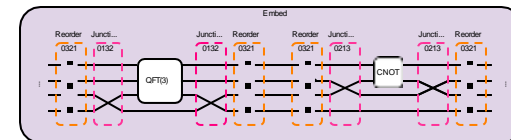

### Scheduling to Quantum "Baremetal"

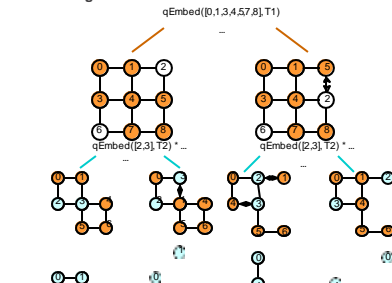

<http://spiralgate.com>  
<https://github.com/cmupiralgene/spiral-package-quantum>  
"Quantum Circuit Optimization with SPIRAL: A First Look", S. Morris, et al, Supercomputing 2020

### QAEF Output: When and where can you leverage quantum computing to achieve advantage in solving your organization's problems?

- Input: the applications that have most potential for quantum advantage. It is critical to identify "real world" problem instances.
- Output: when and where will quantum advantage exist? Establish timeframe for Quantum Advantage Readiness.

Presentation Name

# SEI-CMU Quantum Resource Estimation

# Quantum Resource Estimation

- circuit widths (number of qubits)
- depths (number of gate operations)

**Quantum Advantage (QA)** = Are you getting a speedup/quality improvement over classical or not?

We have reviewed 3 broad Application areas: Machine Learning, Combinatorial Optimization, **Hamiltonian**

**Simulation** and evaluate which has the best chance of realizing a QA in 1-3 years

# Case-study QAOA-MaxCut (SEI LENS FY20)

- We evaluated QAOA-MaxCut against different classical solver modalities: [https://iopscience.iop.org/article/10.1088/2058-9565/ac6973/meta?casa\\_token=wOgiaz0VWTIAAAAA:YKamLf3cNTp1MoZ6AEPnZ5A\\_9oC0imXHQWMytaN\\_BuoNOlgThZxDwkVuzDyfsC8BXu99liwDR\\_IIzvnzNL](https://iopscience.iop.org/article/10.1088/2058-9565/ac6973/meta?casa_token=wOgiaz0VWTIAAAAA:YKamLf3cNTp1MoZ6AEPnZ5A_9oC0imXHQWMytaN_BuoNOlgThZxDwkVuzDyfsC8BXu99liwDR_IIzvnzNL)
- Using variational parameter training, QAOA is competitive with classical but in a **NOISELESS** setting. Noise will likely decrease performance, on the  $O(p\_error^{depth})$ . Performance of QAOA-Noiseless is competitive with classical, but with classical utilizing only a single CPU core.
- To achieve practical QA, circuit widths  $O(1e2-1e3)$  and depths  $O(1e3-1e4+)$  are needed to reach classically-hard-ish instances, performance improvement maybe **only** polynomial or even constant factor, highly-heuristic.
- Because of these results, and others from DARPA ONISQ, we deemed CombOp a lesser candidate for near-term QA compared with HamSim, both in terms of needed resources and expected performance improvement.

# QRE for Hamiltonian Simulation

- Variational Quantum Eigensolver (VQE): variational optimization algorithm designed to find ground states of Hamiltonians (similar to other VQA like QAOA).
- Optimised variational algorithm to calculate ground state energies in a 2D Fermi-Hubbard model. A  $5 \times 5$  instance (larger than can be solved exactly classically) on a 50Q device with approximately **325 2-Q gates** (on a fully connected architecture). <https://arxiv.org/abs/1912.06007>
- We conclude that VQE circuits that are able to represent the ground state of the KAFH on lattices inaccessible to exact diagonalization techniques may be achievable on near-term quantum hardware. However, for large systems, circuits with many variational parameters are needed to achieve high fidelity with the ground state. <https://arxiv.org/abs/2108.08086>
- We perform resource estimation for both silicon spin qubits and superconducting qubits for a **50-qubit** simulation, which cannot be solved exactly via classical means, and find similar results. The number of two-qubit gates required is on the order of **20,000**. Hence, to suppress the mean circuit error count to a level such that we can obtain meaningful results with the aid of error mitigation, we need to achieve a two-qubit gate error rate of  $\sim 1e-4$ . <https://arxiv.org/abs/1910.02719>
- Fermi-Hubbard model is the simplest FCI system that is classically hard.

QRE

50Qubits - 325gates

50Qubits - 550gates

50Qubits - 20,000gates

Presentation Name

# SEI-CMU Quantum Work

# Near Term Outlook and Cybersecurity

OUSD R&E desires SEI to provide research and analysis to answer a congressional tasker embedded in Section 214 of the Fiscal Year 2021 NDAA, which requires the “Secretary of each military department” to “develop and annually update a list of technical problems and research challenges which are likely to be addressable by quantum computers available for use within the next one to three years”. SEI will also provide a potential roadmap for utilization of quantum computing.

## 2.2 Identification of Key Challenges in Early-Stage Quantum Computing and Key Areas of Application

- Analysis and reports suitable for addressing the NDAA request
- Educational materials for identifying suitable areas of research
- Analysis and reports for analyzing adoption concerns
- Workshop Reports

## 2.3 Cyber Protection for US Proprietary Assets

- Report(s) describing cyber protection issues

# Cybersecurity Threats to Quantum Computers

- **Because of the challenges in NISQ-era quantum computing:**
  - In the near-future, quantum computers will likely be used as co-processors in hybrid systems
  - Classical computers hand off mathematical calculations to QCs as part of larger system workflow
- **Understanding the classical-quantum computer integration is essential to considering cyber threats**
  - Classical-quantum interface of NISQ-era is ripe for cybersecurity threats
  - This interface gateway can serve as conduit for known classical computer exploits to traverse into quantum areas

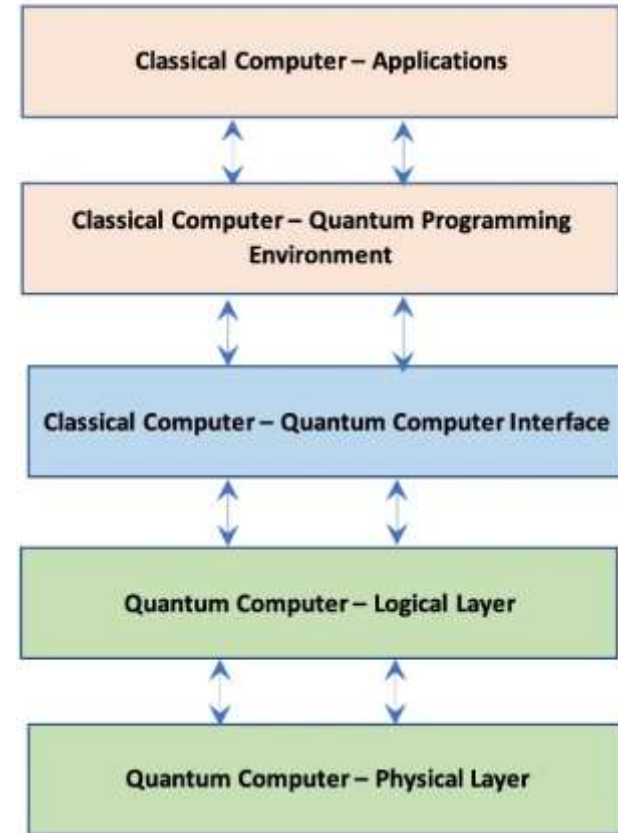

**Notional Model of Classical-Quantum Hybrid Computer**



# Talks and Workshops

Below we give a summary of recent activities:

**APS March 2020 QAOA MaxCut, ... about 5 more conferences (Supercomputing 2021, IEEE HPEC 2021,) NOTE**

**Variational Hamiltonian Diagonalization for Dynamical Quantum Simulation (DOD-NRL) February 2022**  
Ben Commeau talk at NRL to Computational Chemistry Division and Gerald Borsuk Director.

**Variational Hamiltonian Diagonalization for Dynamical Quantum Simulation (NETL) March 2022**  
Ben Commeau talk at NETL to Computational Chemistry Division.

**Quantum Computing of Many-Particle Quantum-Mechanical Systems, Daniel Gunlycke NRL March 2022.**  
Recently developed Methods and techniques for optimal use of limited quantum computing resources currently available for material science problems.

**Workshop on Cybersecurity of Quantum Computing, November 2022**

**Planned:**

**IEEE Quantum Week 2023 Quantum Software Arch** <https://qce.quantum.ieee.org/2023/workshops-program/>

Presentation Name

# Other SEI Expertise

# SEI Quantum Expertise and Experience

- **Quantum Sensors/Sensing**
  - Quantum Magnetometers
  - Rydberg Antennas
- **Quantum Computing/Algorithms**
  - Understanding how and when to apply and utilize quantum computers and/or algorithms to relevant mission needs or challenges
- **Quantum Cryptography**
- **Quantum AI**
- **Quantum Education**
  - Technical staff teaching courses through CMU
  - Quantum education for DoD missions (and SEI reputation)

Presentation Name

# Collaboration Opportunities

# Collaboration Opportunities

**Leverage Quantum Computing for strategic use**

**Identify opportunities for Quantum Advantage**

**Match Quantum applications with available resources**

**Prepare and transfer data to quantum computers**

**Implement algorithms in quantum computers**

**Return and verify quantum computing results**

**Exploit Quantum Sensing and Metrology**

**Explore opportunities for Quantum communication and Networking**

**Quantum Computing Education and Training**

# SEI Quantum Team



**Catherine Bernaciac**  
Sr. Researcher



**Jason Larkin**  
Sr. Researcher



**William Nichols**  
Principal Engineer



**Daniel Justice**  
Software Developer



**Ben Commeau**  
Sr. Researcher



**Joseph McIlvenny**  
Sr. System Designer



**Michael McCall**  
Associate Software Security Engineer

Presentation Name

# Backup

# Quantum Advantage Evaluation Framework (QAEF)

***Work inspired by “Evaluation of QAOA based on the approximation ratio of individual samples”***

“A Review on Quantum Approximate Optimization Algorithm and its Variants”

Blekos et.al. <https://arxiv.org/pdf/2306.09198.pdf>

“Larkin et al. [156] proposed a new metric for evaluating the runtime performance of QAOA in solving the MaxCut problem. They focused on the probability of observing a sample above a certain threshold. Given a desired approximation ratio value, QAOA’s efficiency is measured by the time needed to observe at least one sample with the desired approximation ratio, with a probability of at least 50%. In this sense, the efficiency could also be seen as the number of circuit repetitions before a cut value above a fixed approximation ratio is observed. Specifically, they considered the approximation ratio  $\alpha$  and calculated the likelihood of observing a cut value above  $\alpha C_{\max}$  in the first  $K$  samples. When this probability exceeded 50%, they took  $K$  as the expected number of repetitions needed to obtain the desired approximation. By doing so, in the training phase of the algorithm, the authors managed to reduce the execution time for MaxCut on random 3-regular graphs by two orders of magnitude compared to previous estimates reported in [151]. This was achieved by reducing the number of samples used to calculate the average approximation ratio and also by treating single samples as candidate solutions without waiting for the parameters’ optimization to converge. The performance of QAOA was also evaluated in comparison with some of the best classical alternatives, i.e., an exact solver (AKMAXSAT) [157], an approximate solver (GW) [53], and a heuristic solver (DESOUSA2013) [158]. Thanks to the improved efficiency in the proposed parameter optimization process and approximation ratio calculation, the runtime performance of the QAOA was competitive concerning the aforementioned solvers. However, further studies are required to assess the effectiveness and scalability of this approach on different types of graphs and larger instance sizes”

# Quantum Advantage Evaluation Framework (QAEF)

Applications: CombOp, MatSci, ML

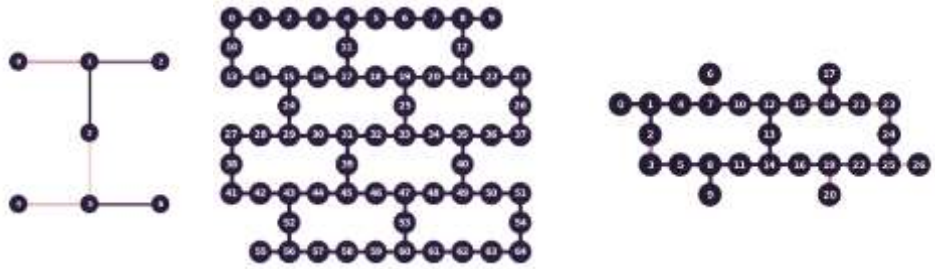
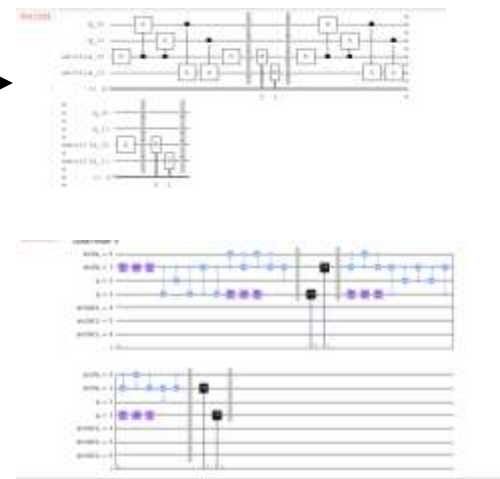
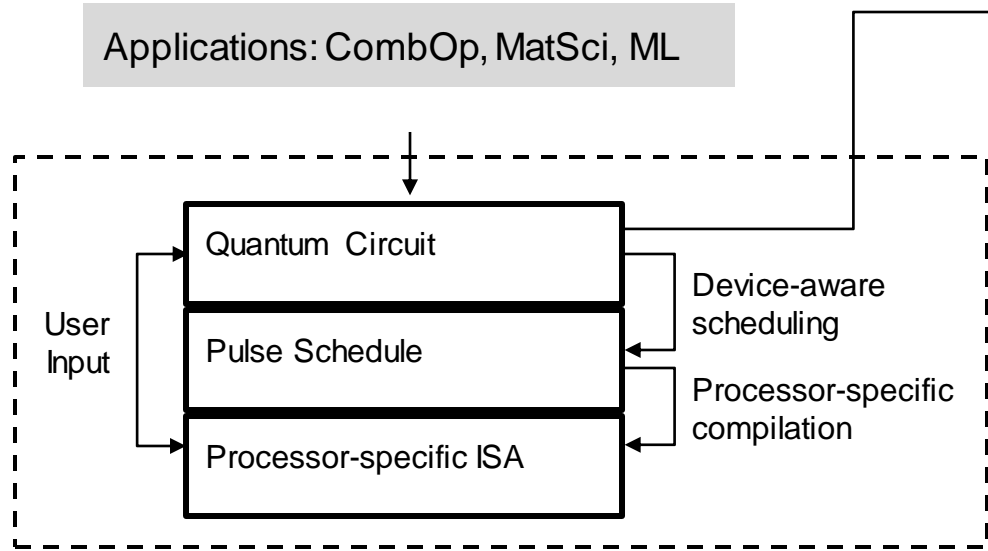

# Quantum Advantage Evaluation Framework (QAEF)

*“Evaluation of QAOA based on the approximation ratio of individual samples”*

Maybe a few slides

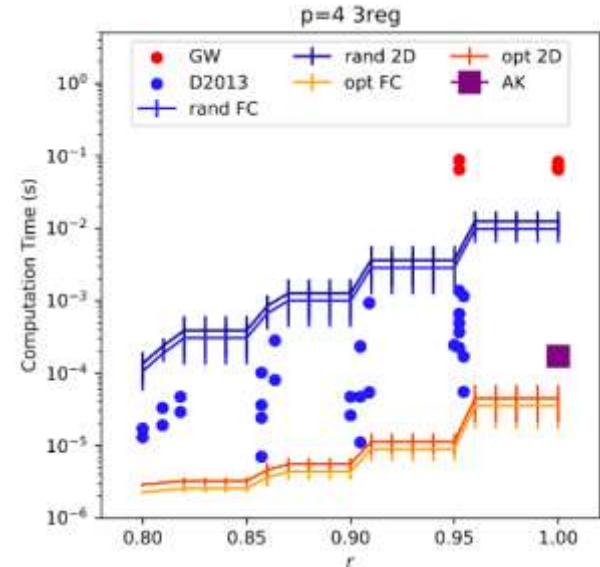

# QRE for VQE: IonQ Proposal

Benjamin Commeau, Daniel Gunlycke, and Jason Larkin

March 2022

- We are actively engaged in research to minimize VQE (and other VQA) circuit resource requirements (e.g. minimize QRE). Proposal to utilize Gunlycke's Symmetry Configuration Mapping (SCM) on NISQ baremetal.

## Symmetry Configuration Mapping for Representing Quantum Systems on Quantum Computers

Sean A. Fischer and Daniel Gunlycke\*

*U.S. Naval Research Laboratory, Washington, DC 20375, USA*

Quantum computing has the potential to significantly speed up complex computational tasks, and arguably the most promising application area for near-term quantum computers is the simulation of quantum mechanics. To make the most of our limited quantum computing resources, we need new and more compact algorithms and mappings. Whereas previous work, including recent demonstrations, has focused primarily on general mappings for fermionic systems, we propose instead to construct customized mappings tailored to the considered quantum mechanical systems. Specifically, we take advantage of existing symmetry, which we build into the mappings a priori to obtain optimal compactness. To demonstrate this approach, we have performed quantum computing calculations of the fluorine molecule, in which we have mapped 16 active spin-orbitals to 4 qubits. This is a four-fold reduction in the qubit requirement, as compared to the standard general mappings. Moreover, our compact system-to-qubits mappings are robust against noise that breaks symmetry, thereby reducing non-statistical errors in the computations. Furthermore, many systems, including  $F_2$ , are described by real Hamiltonians, allowing us to also reduce the number of single-qubit operations in the hardware-efficient ansatz for the quantum variational eigensolver by roughly a factor of three.

## 1 Research Proposal

A recent method provides state of the art quantum circuit resource compression for material science problems called "Symmetry Configuration Mapping (SCM) for Representing Quantum Systems on Quantum Computers [1]." SCM achieves the best quantum circuit resource compression possible by selecting all desired symmetries in the quantum Hamiltonian and removing all undesired symmetries. Our goal is to simulate  $F_2$ .

Our requested resources are 32 qubits, 512 shots per iteration, 256 iterations, and 256 two-qubit gates per iteration. Using IonQ's resource calculator [2] this comes to a budget of \$10,066.33 which is approximately within the maximum allowed budget of \$10k. We plan to iteratively step through smaller qubit system sizes to provide sufficient feedback to run larger qubit systems up to 32 qubits within this resource request.

Here is the reasoning for the requested resources: 32 qubits are required because 32 qubits is the maximum allowed qubits and at least 50 qubits or more are needed for reaching classically intractable problems. 512 shots per iteration to achieve a shot noise error below 0.05. 256 iterations for a combination of variational optimization steps and number of unitaries expressing the Hamiltonian. 256 two-qubit gates per iteration to ensure sufficient coverage of the Hilbert space to find the ground state.

Once we have obtained our results from the \$10k resource budget, we plan to extrapolate from those results larger simulations using larger IonQ resource budgets. This will lead to towards a publication. ■

1

DEPARTMENT OF DEFENSE LIMITED DISTRIBUTION This information has not been approved for public release. Further dissemination must be approved by the Commanding Officer, NRL.

DRAFT DISCLAIMER The entire content of this DRAFT information exchange is provided for the purposes of discussion on the plan of work and does not constitute a final proposal for the work described by NRL. A final proposal will be submitted upon request by the offeror.

# Updating the Distribution Statement in the Footers

To update the distribution statement in the footers of your presentation, follow these steps:

1. From the Home tab, select Replace at the right side of the toolbar.
2. Paste [DISTRIBUTION STATEMENT Please copy and paste the appropriate distribution statement into this space.] in the Find What field.
3. Paste a short version of the distribution statement provided by the Document Marking System in the Replace With field. (See the table on the next slide for the short statements you can use. If you have questions, send email to [DMARR-Team@sei.cmu.edu](mailto:DMARR-Team@sei.cmu.edu).)
4. Click the Replace All button. Voilà! You're done!

You can adapt these instructions to update other information (e.g., title, date, copyright) in your presentation without having to access slide master pages.

# Quantum Computing Attack Vector Examples

- **Known cyber attack techniques for classical computers to compromise a NISQ-era hybrid system**
- **Control and measurement devices for quantum computers, such as:**
  - Application-specific integrated circuits (ASICs)
  - Field-programmable gate arrays (FPGAs)
  - Digital to analog converters (DACs) and analog to digital converters (ADCs)
- **Common quantum computing scalability issues can also serve as potential attack avenues, such as:**
  - I/O management
  - Heat and power dissipation
  - System footprint
  - Noise and interference
  - Bandwidth

**Our work in cybersecurity of classical computers has taught us that any system failure can provide an opening to exploit a system.**