

FR-3428

CONSTANT-FREQUENCY CHARACTERISTICS OF A DUAL-FEEDBACK-PATH BRIDGE OSCILLATOR

James M. Headrick

March 3, 1949

Approved by:

F. Malcolm Gager, Head, Special Research Section
Dr. R. M. Page, Superintendent, Radio Division III



NAVAL RESEARCH LABORATORY

CAPTAIN F. R. FURTH, USN, DIRECTOR
WASHINGTON, D.C.

Distribution Unlimited

Approved for
Public Release

DISTRIBUTION

ONR	1
Attn: Code 400	1
Attn: Code 402	6
Attn: Code 413	1
Attn: Code 420	1
Attn: Code 460	1
CO, ONR, Boston	1
CO, ONR, Brooklyn	1
CO, ONR, Chicago	1
CO, ONR, Los Angeles	1
CO, ONR, San Francisco	1
Ass't Naval Attache for Research, FPO, N. Y., N. Y.	1
BuAer	5
Attn: Code TD-4	5
BuShips	5
CNO	5
Attn: Code Op-413-B2	5
Dir., USNEL	2
Cdr., USNOTS	2
Attn: Reports Unit	2
SNLO, USNELO	1
Cdr., NATC	1
OCSigO	1
Attn: Ch. Eng. & Tech. Div., SIGTM-S	1
CO, SCEL	2
Attn: Dir. of Engineering	2
BAGR, CD, Wright-Patterson Air Force Base	1
Attn: BAU-ADD	1
CG, AMC, Wright-Patterson Air Force Base	1
Attn: Eng. Div., Electronics Subdiv., MCREEO-2	1
CO, 4151st Air Force Base Unit, Red Bank, N. J.	1
Attn: Ch. Eng. Div., WLENG	1

DISTRIBUTION (Cont.)

CO, 4153rd Air Force Base Unit, Cambridge Attn: ERCAJ-2	1
RDB	
Attn: Library	2
Attn: Navy Secretary	1
Science and Technology Project Attn: Mr. J. H. Heald	2
BuOrd	1
Dir., NBS	1
CO, NADS	1

CONTENTS

Abstract	vi
Problem Status	vi
Authorization	vi
INTRODUCTION	1
CIRCUIT ANALYSIS	2
EXPERIMENTAL CHARACTERISTICS	7
Crystal Oscillator	7
Variable-Frequency Oscillator	.13
CONCLUSIONS	13

ABSTRACT

A theoretical and experimental analysis is undertaken of the constant-frequency characteristics of a transformer-less, dual-path bridge, feedback oscillator circuit. Its frequency stability is found to compare favorably with that of a single-feedback-path bridge oscillator, one of the most stable known, and use of the circuit is indicated wherever its form factor offers advantages. The circuit lends itself to operation over a wide frequency range using either fixed or variable frequency-controlling elements.

PROBLEM STATUS

This report covers a special study related to the main problem; work on the over-all problem is continuing.

AUTHORIZATION

NRL Problem No. R10-49D.

CONSTANT-FREQUENCY CHARACTERISTICS OF A DUAL-FEEDBACK-PATH BRIDGE OSCILLATOR

INTRODUCTION

In a previous Naval Research Laboratory report,¹ a vacuum-tube oscillator circuit is discussed and some experimentally determined characteristics are given. This oscillator is composed of a linear, zero phase-shift amplifier and a bridge-feedback network containing the desired frequency-controlling elements. The elementary oscillator circuit (see Figure 1) may be considered a dual-feedback-path variation of the oscillator due to Meacham.² The bridge constants are such that the system is near balance, and the value of one bridge resistance is current-sensitive, thereby adjusting attenuation through the bridge to be equal to the reciprocal of loop gain and providing the amplitude-control of oscillation. This current-sensitive resistance is essentially linear over any one oscillation cycle. The amplifier stage of tube V_1 is tuned in order to obtain high gain and zero phase shift with a minimum of components. The cathode-follower stage of tube V_2 is used to obtain a low-impedance drive to the bridge. The grid and cathode of tube V_1 are operated approximately symmetrical about ground to obtain, without transformers, the single-side to double-side conversion required by the bridge-feedback network. This last feature introduces a second feedback path due to the plate current of tube V_1 flowing through the bridge.

The circuit as shown in Figure 1 is considered to offer advantages over a single-feedback-path oscillator in certain applications because it eliminates any necessity for tuned output and input transformers for the single-side to double-side transformation and impedance-matching. Specifically the advantages are:

1. Operation over a wide frequency range.
2. Elimination of transformers for applications where their temperature characteristics are undesirable.
3. Localization of sources of amplifier phase-shift deviations to plate load of tube V_1 .
4. Construction with a small number of components.

¹ F. M. Gager and J. M. Headrick, "Fixed and Variable Frequency Oscillators with Improved Frequency Stability," NRL Report R-3082, May 1947.

² L. A. Meacham, Proc. I.R.E., 26, 1278-1294, October 1938.

CIRCUIT ANALYSIS

In Figure 2 an equivalent circuit of the dual-feedback-path oscillator is given. One bridge resistance is assumed to have a value that is a function of its conducting alternating current (so as to maintain oscillation at a stable level) but to change resistance slowly enough that its value is substantially constant over any one cycle. The desired frequency-controlling element, impedance Z_4 , may be either a series-resonant circuit or an electromechanical resonator, such as a quartz crystal. Bridge-arm impedances are considered sufficiently small to allow disregard of the stray capacities.

The network determinant may be written:

$$D = \begin{vmatrix} Z_{11} & -Z_{12} & -Z_{13} \\ -Z_{21} & Z_{22} & -Z_{23} \\ -Z_{31} & -Z_{32} & Z_{33} \end{vmatrix}$$

where

$$\begin{aligned} Z_{11} &= r_{p1} + Z_b + R_3, \\ Z_{22} &= R_1 + R_2 + R_3 + Z_4, \\ Z_{33} &= R_k + R_1 + Z_4, \\ Z_{21} &= Z_{12} = R_3, \\ Z_{32} &= Z_{23} = R_1 + Z_4, \\ Z_{31} &= Z_{13} = 0, \end{aligned}$$

and

$$R_k = \frac{r_{p2}}{\mu_2 + 1}.$$

Letting

$$\mu_1 e = E_1$$

and

$$\frac{\mu_2 E_{g2}}{\mu_2 + 1} = E_3,$$

the currents may be written

$$I_2 = \frac{E_1 Z_{12} Z_{23} + E_3 Z_{23} Z_{11}}{D}$$

and

$$I_3 = \frac{E_1 Z_{12} Z_{23} + E_3 (Z_{11} Z_{22} - Z_{12}^2)}{D}.$$

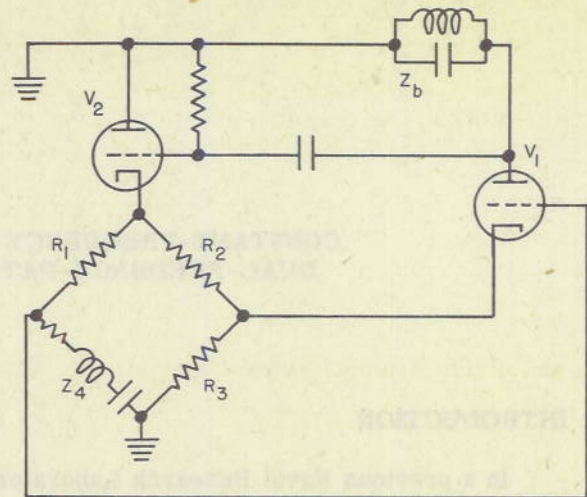

Fig. 1 - Elementary circuit diagram of oscillator

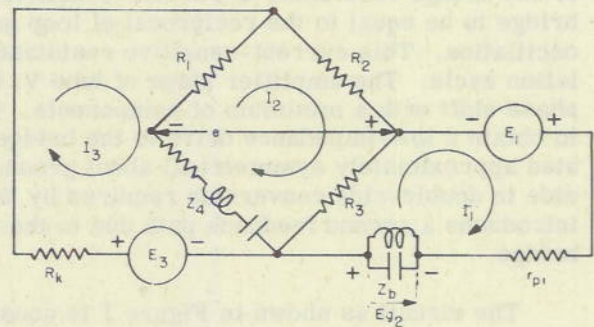

Fig. 2 - Equivalent circuit of oscillator

Since the bridge output voltage

$$e = -I_2 (R_1 + R_2) + I_3 R_1,$$

substituting for currents gives

$$e = \frac{E_3 (Z_{11} Z_{22} R_1 - Z_{12}^2 R_1 - Z_{23} Z_{11} R_1 - Z_{23} Z_{11} R_2)}{D} + \frac{E_1 (Z_{12} Z_{23} R_1 - Z_{12} Z_{33} R_1 - Z_{12} Z_{33} R_2)}{D};$$

and dividing numerator and denominator by Z_{11} results in

$$e = \frac{E_3 \left(R_1 R_3 - R_2 Z_4 - \frac{R_1 R_3^2}{Z_{11}} \right) - \frac{E_1 R_3}{Z_{11}} \left(R_1 R_k + R_2 R_k + R_1 R_2 + R_2 Z_4 \right)}{R_1 R_2 + R_1 R_3 + R_2 Z_4 + R_3 Z_4 + R_k (R_1 + R_2 + R_3 + Z_4) - (R_1 + Z_4 + R_k) \frac{R_3^2}{Z_{11}}}. \quad (1)$$

At this point there are placed on the circuit certain restrictions that can be met in practical design and which will simplify analysis, namely, that

$$Z_{11} \gg R_3,$$

to the extent that the terms $R_1 R_3^2 / Z_{11}$ and $(R_1 + Z_4 + R_k) R_3^2 / Z_{11}$ may be neglected in equation (1). In general this means that the Q of Z_4 must be large, so that bridge-arm resistances are small by comparison, and that V_1 must have a very large plate resistance and a large load impedance. Normally, both of these requirements are readily met in a good design. Defining amplifier gain as

$$A = \frac{E_3}{e} \approx \frac{E_{g2}}{e}$$

and conductance as

$$G = \frac{\mu_1}{Z_{11}} \approx g_{m2} \quad (\text{transconductance of } V_1),$$

and equation (1) becomes

$$e = \frac{Ae (R_1 R_3 - R_2 Z_4) - Ge R_3 (R_1 R_k + R_2 R_k + R_1 R_2 + R_2 Z_4)}{R_1 R_2 + R_1 R_3 + R_2 Z_4 + R_3 Z_4 + R_k (R_1 + R_2 + R_3 + Z_4)}. \quad (2)$$

Equation (2) describes the condition of oscillation and may be represented by an equivalent circuit as shown in Figure 3. In the subsequent investigation of frequency stability, A will be considered variable both in magnitude and phase and G will be considered a real quantity variable in magnitude. To be rigorous, G must be admitted to vary in phase also; however, its variations are of second order magnitude compared to A . Therefore, a change in both G and the magnitude of A may be identified with change in transconductance of V_1 , and a change in both magnitude and phase of A may be identified with detuning of the plate load of V_1 . Variations in magnitude of A alone may be laid to changes in amplification of V_2 ; however, the cathode-follower performance is insensitive to variations of tube parameters.

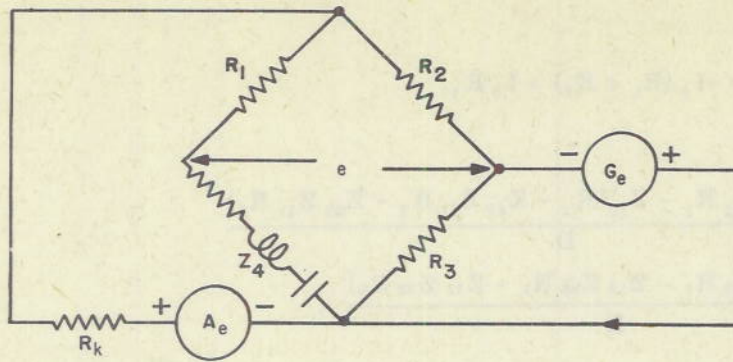

Fig. 3 - Simplified equivalent circuit of oscillator

By eliminating e from equation (2) and substituting A and Z_4 in component form, that is,

$$A = A \angle \theta = A_1 + j A_2,$$

and

$$Z_4 = R_4 + j X_4 = R_4 + j \left(\omega L - \frac{1}{\omega C} \right),$$

the expression describing oscillation condition is

$$I = \frac{(A_1 + j A_2) (R_1 R_3 - R_2 R_4 - j R_2 X_4) - G R_3 (R_1 R_k + R_2 R_k + R_1 R_2 + R_2 R_4 + j X_4 R_2)}{R_1 R_2 + R_1 R_3 + R_1 R_k + R_2 R_k + R_3 R_k + R_4 (R_k + R_2 + R_3) + j (R_k + R_2 + R_3) X_4}.$$

Letting

$$\begin{aligned} B &= R_1 R_3 - R_2 R_4, \\ P &= R_3 (R_1 R_k + R_2 R_k + R_1 R_2 + R_2 R_4), \\ M &= R_1 R_2 + R_1 R_3 + R_1 R_k + R_2 R_k + R_3 R_k + (R_k + R_2 + R_3) R_4, \end{aligned}$$

and

$$N = R_k + R_2 + R_3, \quad 1 = \frac{(A_1 + j A_2) (B - j R_2 X_4) - G (P + j X_4 R_2 R_3)}{M + j N X_4}, \quad (3)$$

or

$$A_1 B - j A_1 R_2 X_4 + j A_2 B + A_2 R_2 X_4 - G P - j G R_2 R_3 X_4 - M - j N X_4 = 0.$$

Equating reals and imaginaries to zero,

$$M - A_1 B - A_2 R_2 X_4 + G P = 0, \quad (4)$$

and

$$N X_4 + A_1 R_2 X_4 - A_2 B + G R_2 R_3 X_4 = 0. \quad (5)$$

If the phase shift is adjusted to be zero ($A_2 = 0$),

$$A_1 = A = \frac{(M + GP)}{B}, \quad (6)$$

$$X_4 = 0,$$

and

$$\omega = \frac{1}{\sqrt{LC}}. \quad (7)$$

With the phase shift zero the frequency of oscillation is controlled by Z_4 alone and is independent of circuit changes.

In order to examine the effects of small phase shifts in A upon frequency, an expression for ω in terms of X_4 is useful. Now

$$X_4 = \frac{\omega^2 LC - 1}{\omega C}.$$

Solving this quadratic,

$$\omega = \frac{X_4}{2L} \pm \left(\frac{X_4^2}{4L^2} + \frac{1}{LC} \right)^{1/2}.$$

Since analysis is restricted to small phase shifts in A, only small differences from zero exist in X_4 so that

$$\frac{X_4^2}{4L^2} \ll \frac{1}{LC}$$

or

$$\omega \approx \frac{1}{\sqrt{LC}} + \frac{X_4}{2L}. \quad (8)$$

By defining

$$\omega_0 = \frac{1}{\sqrt{LC}}$$

and

$$Q = \frac{\omega_0 L}{R_4},$$

$$\frac{\omega - \omega_0}{\omega_0} = \frac{X_4}{2L\omega_0} = \frac{X_4}{2QR_4}. \quad (9)$$

Substituting in equation (9) the value of X_4 given by equation (5),

$$\frac{\omega - \omega_0}{\omega_0} = \frac{A_2 B}{2QR_4(A_1 R_2 + GR_2 R_3 + N)}. \quad (10)$$

Since small phase shifts only are considered, equation (6) holds to a good approximation, and substituting in equation (10) the value of B determined from equation (6),

$$\frac{\omega - \omega_0}{\omega_0} = \frac{\frac{A_2}{A_1} (M + GP)}{2QR_4 (A_1 R_2 + GR_2 R_3 + N)}$$

Since

$$\frac{A_2}{A_1} = \tan \theta \approx \theta$$

and

$$A_1 \approx |A|,$$

$$\frac{\omega - \omega_0}{\omega_0} = \frac{(M + GP)\theta}{2QR_4 (|A| R_2 + GR_2 R_3 + N)}. \quad (11)$$

Considering ω to be a function of θ , $|A|$, and G ,

$$\begin{aligned} \frac{d\omega}{\omega_0} = & \frac{(M + GP)d\theta}{2QR_4 (|A| R_2 + GR_2 R_3 + N)} - \frac{\theta R_2 (M + GP) d|A|}{2QR_4 (|A| R_2 + GR_2 R_3 + N)^2} \\ & + \frac{\theta (|A| R_2 P + NP - MR_2 R_3) dG}{2QR_4 (|A| R_2 + GR_2 R_3 + N)^2}. \end{aligned} \quad (12)$$

The above differentiation is not strictly rigorous, since one bridge resistance is only approximately constant; however, this introduces negligible error. As noted previously, the frequency change is zero for zero phase shift. With small phase shifts the change is approximately proportional to the reciprocal of amplifier gain.

It is of interest to determine an expression for the frequency stability of a single-feedback-path oscillator in order to compare it with equation (12). By setting G equal to zero, the frequency stability of a hypothetical single-feedback-path oscillator is found. Such an oscillator may be supposed to have an ideal one-to-one transformer coupling the bridge output to the grid and cathode of V_1 . For this oscillator

$$\frac{d\omega}{\omega_0} = \frac{Md\theta}{2QR_4 (|A| R_2 + N)} - \frac{\theta R_2 M d|A|}{2QR_4 (|A| R_2 + N)^2}. \quad (13)$$

Comparison of equations (12) and (13) shows that the frequency stability equations take the same form. The single-feedback-path oscillator gives some greater stability for variations in θ , the amount depending upon the relative magnitudes of M and GP . However, the dual-feedback-path oscillator has an interesting feature in that its frequency stability may be made independent of changes in transconductance of tube V_1 . Since for changes in this transconductance $d|A|$ is a linear function of dG , this independence may be accomplished by designing

$$(|A| R_2 P + NP - MR_2 R_3) dG = (M + GP) d|A|.$$

The order of stability afforded by the oscillators may be illustrated by substitution of values for circuit parameters. The values listed below are those suitable for an oscillator with a 100-kilocycle crystal:

$$\begin{aligned} R_k &= 80 \\ R_1 &= 2000 \end{aligned}$$

$R_2 = 600$ (nominal)
 $R_3 = 9$
 $R_4 = 30$
 $Q = 354,000$
 $G = 10^{-2}$ (nominal)
 $A = 3,600$ (nominal)

giving

$P = 12,834,000$
 $M = 1,447,390$

and

$N = 689.$

Substitution of the above values in equation (12) gives

$$\frac{d\omega}{\omega_0} = 3.41 \times 10^{-8} d\theta - 9.47 \times 10^{-12} \theta d|A| + 2.80 \times 10^{-7} \theta dG. \quad (14)$$

The degree of cancellation between the last two terms for this particular oscillator may be shown by substituting an arbitrary 10% change in G for dG and the corresponding 10% change in A for d|A|, the result being

$$-3.4 \times 10^{-9} \theta + 2.8 \times 10^{-9} \theta = -6 \times 10^{-10} \theta.$$

For the single-feedback-path oscillator, substitution in equation (13) results in

$$\frac{d\omega}{\omega_0} = 3.1 \times 10^{-8} d\theta - 8.6 \times 10^{-12} \theta d|A|. \quad (15)$$

The dual-feedback-path oscillator circuit is seen to afford essentially the same frequency stability as may be expected from a single-feedback-path circuit when components are assigned values considered to be in agreement with good design practice. In addition, the dual-feedback-path oscillator offers the possibility of rendering frequency stability independent of transconductance changes in the high-gain amplifier for phase shifts different from zero.

EXPERIMENTAL CHARACTERISTICS

Crystal Oscillator

The circuit shown in Figure 4 was used with crystals as frequency-controlling elements. Two tungsten lamps served as the current-sensitive resistor; lamp characteristics are given in Figure 5. Bridge-arm values were chosen to allow low-level excitation of the crystal where it is comparatively insensitive to amplitude of excitation. The resistor R_3 was varied to set oscillation level initially.

This circuit with appropriate changes in tuned amplifier load was used with crystals

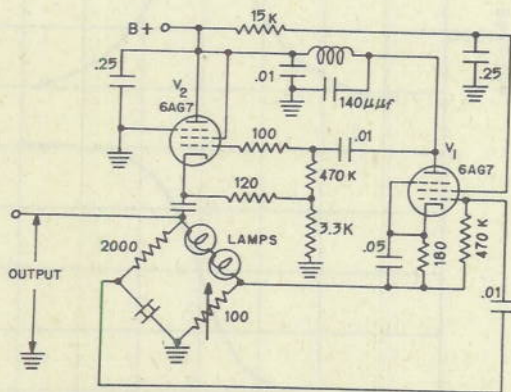

Fig. 4 - Circuit of an experimental crystal oscillator

Fig 5 - Resistance as a function of dissipated power for current-sensitive resistors used in experimental oscillators.

- a - Two 6 watt, 115 volt, tungsten lamps in series
- b - Western Electric D 163903 thermistor

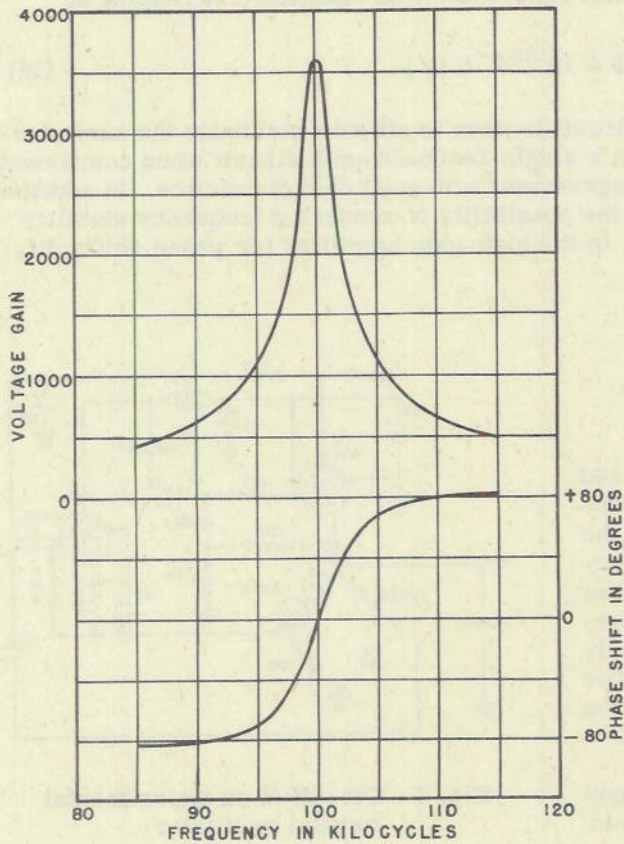
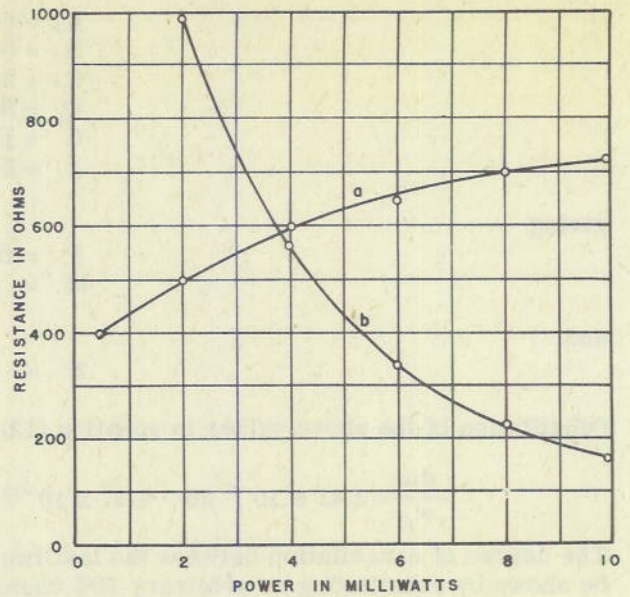

Fig. 6 - Gain and phase shift as a function of frequency for amplifier of experimental oscillator operated at 100 kilocycles

having series-resonant frequencies of 50, 100, 250, 500, 1000, 2000, and 6000 kilocycles. With the amplifier adjusted for zero phase shift, it was possible to vary supply voltages (either filament or plate, or both) plus or minus 20% without causing any measurable change in the frequency of oscillation. Crystals of sufficient inherent stability to warrant a good degree of isolation from the driving circuit were available at 100 and 250 kilocycles, and extensive stability studies of the dual-feedback-path crystal oscillator were confined to these two frequencies.

In Figure 6 the gain and phase-shift characteristics of the tuned amplifier are given for the plate-load impedance used at 100 kilocycles; small changes in tuning correspond closely to shifting the curves along the frequency axis. Figures 7 and 8 give oscillation level and amplifier gain as a function of supply voltages.

The frequency change of the oscillator with a phase-shift change from zero to 0.5 radian was measured to be approximately 3 parts in 10^6 . Figure 6 indicates that with a phase shift of 0.5 radian the associated change in gain is 900. Substituting these values for $d\theta$ and $d|A|$ in equation (14) and neglecting any second order terms,

$$d\omega/\omega_0 = 1.7 \times 10^{-8} + 0.43 \times 10^{-8} = 2.13 \times 10^{-8}.$$

Since equation (14) cannot be expected to hold precisely for such large changes in θ , the agreement with the measured 3 parts in 10^8 is considered good.

In Figures 9 and 10 oscillator-frequency change is shown as a function of supply voltages with the amplifier tuned to 90, 100, and 110 kilocycles. Reference to Figure 6 shows that detuning to 90 to 110 kilocycles introduces a phase shift of approximately 80 degrees and reduces the gain from 3600 to approximately 1100. Such changes in amplifier tuning are quite extreme and result in an oscillation-frequency deviation of approximately 2.5 parts in 10^7 with normal supply voltages.

Figures 11, 12, and 13 give oscillator characteristics when used with a 250-kilocycle crystal and amplifier tuned to 250 kilocycles. Figures 14 and 15 show frequency change as a function of supply voltages for different amplifier tunings. In general, these results are similar to those obtained at 100-kilocycle operation. Phase shifts of 80 degrees, with accompanying reduction in gain from 350 to 100, result in an oscillation-frequency deviation of approximately 1 part in 10^6 .

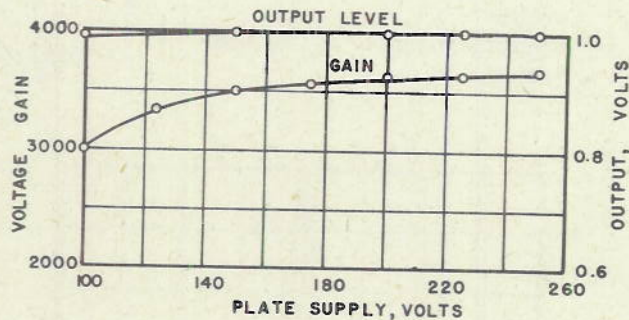

Fig. 7 - Output voltage and amplifier gain versus plate supply voltage for experimental oscillator at 100 kilocycles

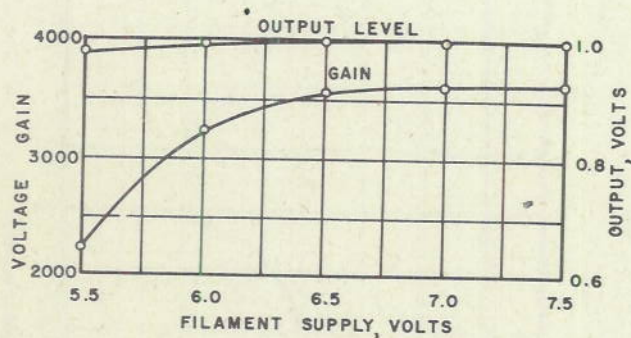

Fig. 8 - Output voltage and amplifier gain versus filament supply voltage for experimental oscillator at 100 kilocycles

Fig. 9 - Frequency change versus plate supply voltage for experimental oscillator with 100 kilo-cycle crystal

- a - Amplifier tuned to 110 kilo-cycles
- b - Amplifier tuned to 100 kilo-cycles
- c - Amplifier tuned to 90 kilo-cycles

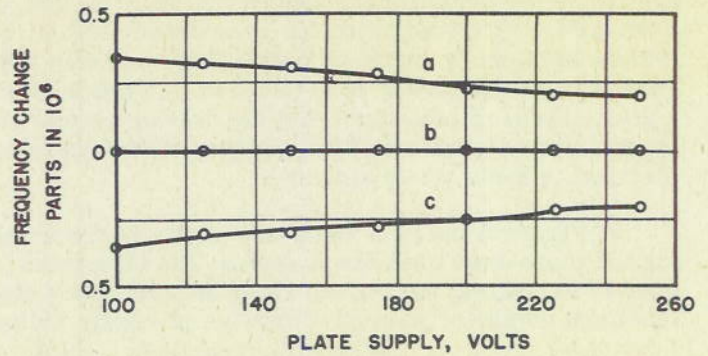

Fig. 10 - Frequency change versus filament supply voltage for experimental oscillator with 100-kilo-cycle crystal

- a - Amplifier tuned to 110 kilo-cycles
- b - Amplifier tuned to 100 kilo-cycles
- c - Amplifier tuned to 90 kilo-cycles

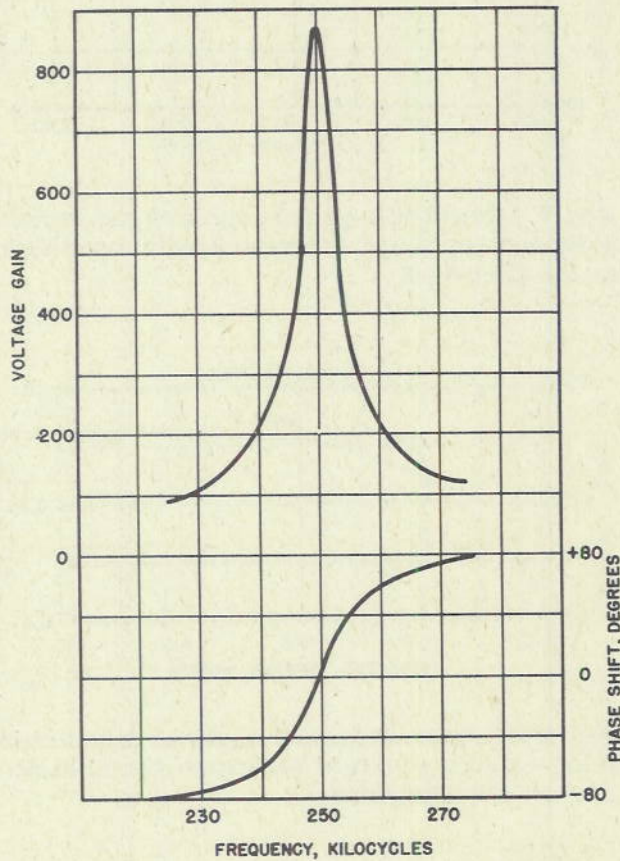
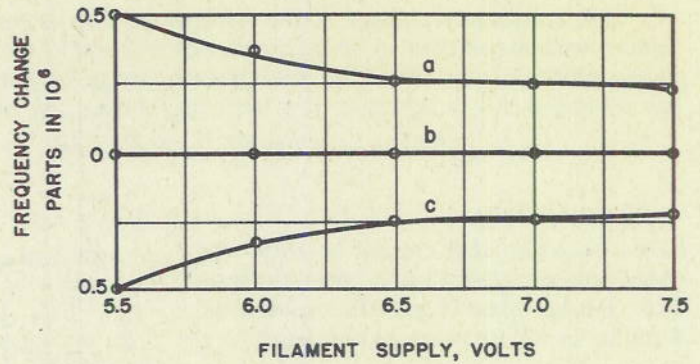

Fig. 11 - Gain and phase shift as a function of frequency for amplifier of experimental oscillator operated at 250 kilocycles

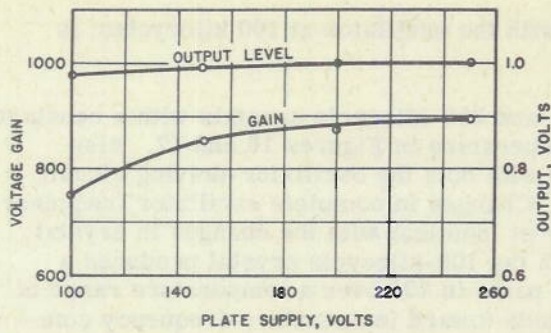

Fig. 12 - Output voltage and amplifier gain versus plate supply voltage for experimental oscillator at 250 kilocycles

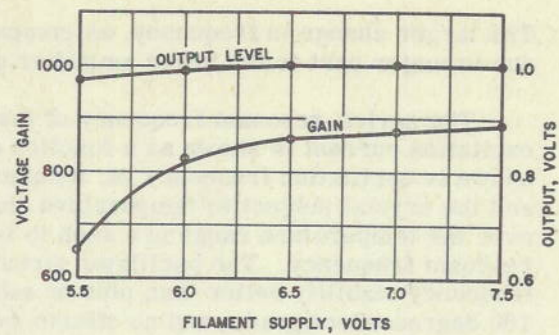

Fig. 13 - Output voltage and amplifier gain versus filament supply voltage for experimental oscillator at 250 kilocycles

Fig. 14 - Frequency change versus plate supply voltage for experimental oscillator with 250-kilocycle crystal
 a - Amplifier tuned to 275 kilocycles
 b - Amplifier tuned to 250 kilocycles
 c - Amplifier tuned to 225 kilocycles

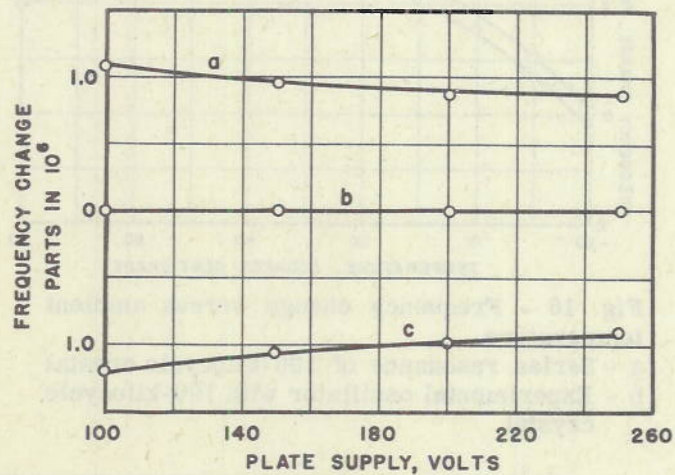
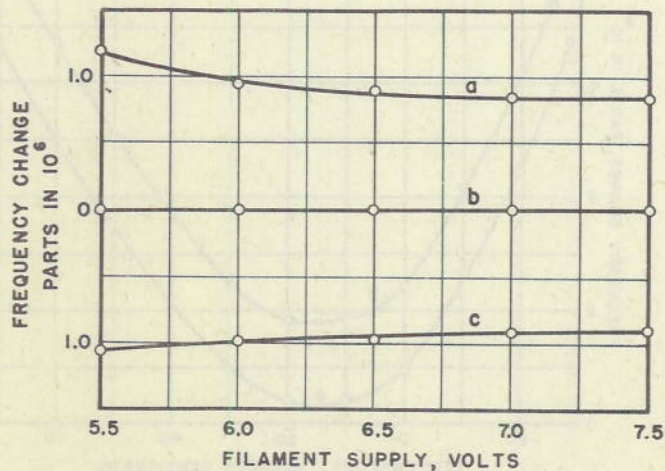

Fig. 15 - Frequency change versus filament supply voltage for experimental oscillator with 250-kilocycle crystal
 a - Amplifier tuned to 275 kilocycles
 b - Amplifier tuned to 250 kilocycles
 c - Amplifier tuned to 225 kilocycles



The larger change in frequency, as compared with the oscillator at 100 kilocycles, is due in major part to the lower amplifier gain.

The series-resonant frequency of the 100- and 250-kilocycle crystals with a constant excitation current is shown as a function of temperature in Figures 16 and 17. Also shown is oscillation frequency vs. temperature with both the oscillator-driving circuit and the crystal subject to temperature change. Changes in complete oscillator frequency over the temperature range are seen to be almost identical with the changes in crystal resonant frequency. The oscillator circuit with the 100-kilocycle crystal produces a frequency stability better than plus or minus 2 parts in 10^6 over a temperature range of 100 degrees Centigrade, and no efforts were made toward temperature-frequency compensation of circuit components.

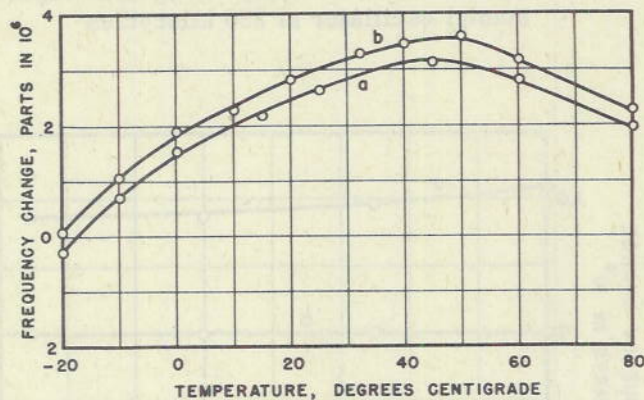

Fig. 16 - Frequency change versus ambient temperature.
a - Series resonance of 100-kilocycle crystal
b - Experimental oscillator with 100-kilocycle crystal

It should be noted that effective crystal resistance and the value of the current-sensitive resistor change appreciably over a wide temperature range, requiring that some bridge arm be adjusted if oscillation level is kept constant. Measurements showed it possible to perform this adjustment with an appropriate ambient-temperature-sensitive thermistor in one bridge arm. As an alternative, a rudimentary vacuum-tube voltmeter may be included with the oscillator and the oscillation level set to a standard manually when large changes in ambient temperature are encountered.

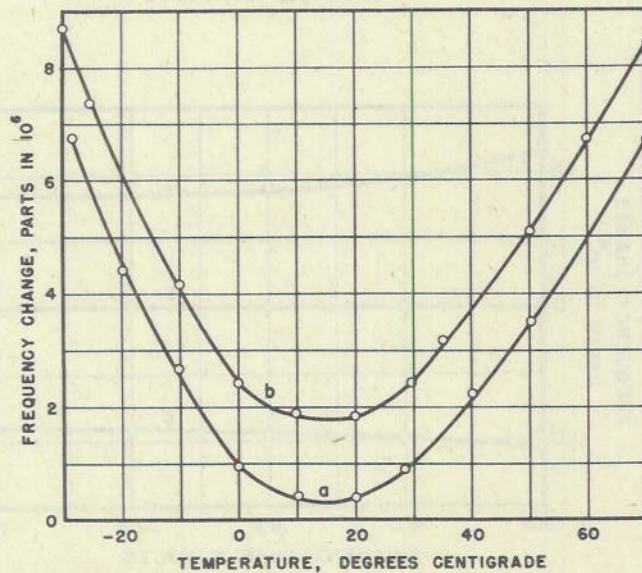

Fig. 17 - Frequency change versus ambient temperature
a - Series resonance of 250-kilocycle crystal
b - Experimental oscillator with 250-kilocycle crystal

Variable-Frequency Oscillator

A circuit diagram of a variable-frequency version of the dual-feedback-path oscillator is shown in Figure 18. The thermistor whose characteristic is given in Figure 5 serves as a current-sensitive resistor. If the amplifier is adjusted for zero phase shift, the oscillation frequency is essentially independent of variations in supply voltages. The curves marked 'a' in Figure 19 show oscillation frequency and output voltage vs. plate supply voltage at 1 megacycle. Oscillator instability with plate supply voltage variations over the frequency range 0.7 to 2.4 megacycles is shown in Figure 20, this range being covered by three sets of plug-in coils. The larger instability at the high-frequency end of each band is principally due to failure in tracking between the ganged condensers of the tuned amplifier and the frequency-controlling element. It is also due, in part, to the fact that tube capacities constitute a larger portion of amplifier tuning capacity at the high-frequency end of tuning range.

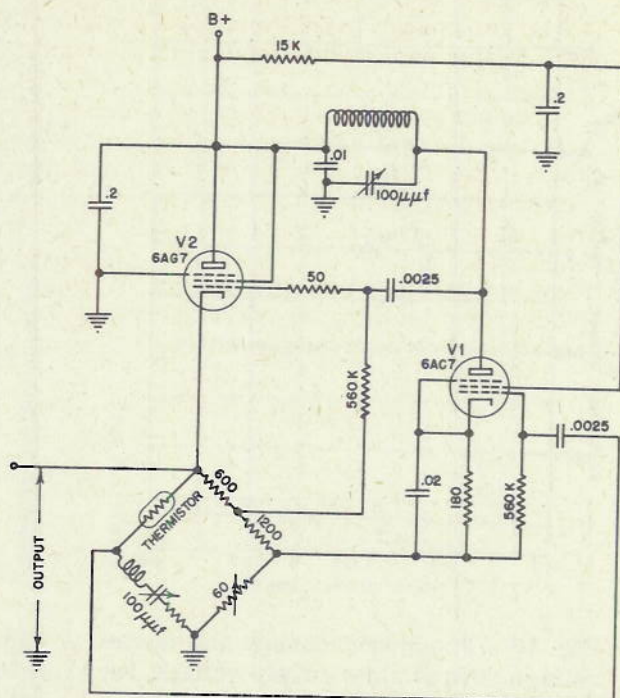

Fig. 18 - Circuit of an experimental variable-frequency oscillator

The curves marked 'b' in Figure 19 show oscillation frequency and output voltage vs. plate voltage with the inductance-capacity series-resonant circuit in the bridge replaced by a resistance and a series-blocking condenser of negligible impedance. This data gives some idea of the isolation afforded the frequency-controlling element when located in the bridge.

CONCLUSIONS

The dual-feedback-path oscillator, as described in this report, provides one approach to complete oscillation-frequency determination by a selected frequency-controlling element. If the phase shift through the driving-circuit amplifier is held to zero, the frequency is independent of any changes in the driving circuit. Considering oscillation-frequency changes due to small amplifier phase shifts, the dual-feedback-path oscillator offers the same order of stability as is given by the conventional single-feedback-path oscillator, and therefore this circuit may be used wherever its form factors are desirable.

The source of phase shift in the present oscillator, unlike the single-feedback-path type, is localized to one simple parallel-resonant circuit, the tuned-amplifier load impedance. Thus, any efforts toward increasing the isolation of the desired frequency-controlling element from the driving circuit may be confined to reducing phase-shift variations introduced at this point. In addition, the driving circuit may be designed to render oscillation frequency independent of tuned-amplifier transconductance variations over a narrow phase-shift range.

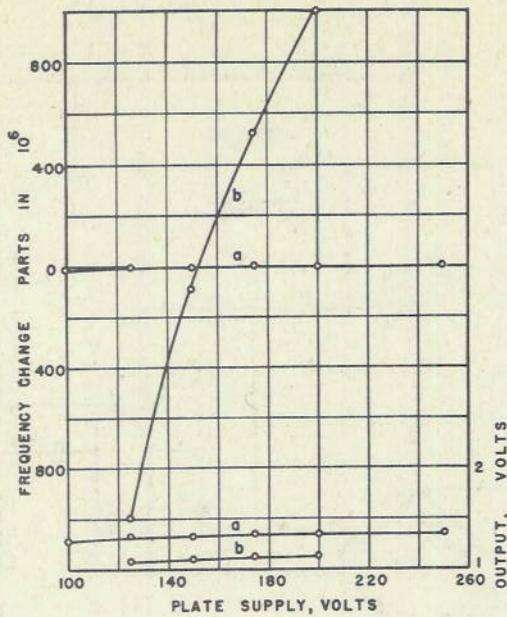

Fig. 19 - Frequency change and output voltage versus plate supply voltage for experimental variable-frequency oscillator operating at 1 megacycle
 a - Oscillator as shown in Figure 18
 b - Bridge-arm coil and condenser replaced by a resistance

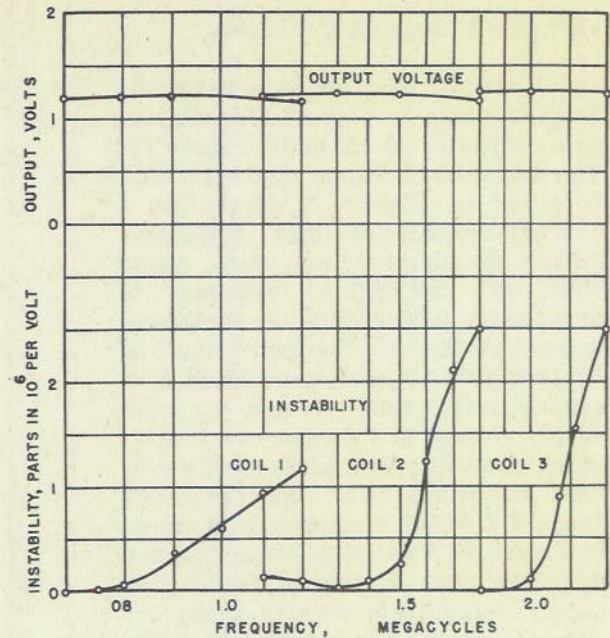

Fig. 20 - Instability and output voltage versus frequency for experimental variable-frequency oscillator. Instability defined as frequency change per change in plate supply voltage

The same driving circuit may be used with a number of successive frequency-controlling elements ranging over a wide frequency band. The circuit modification required when changing frequency-controlling element is appropriate adjustment of tuned amplifier load, such as substituting a new inductance and adjusting condenser capacitance. By using a tunable frequency-controlling element and suitable ganging with the tuned amplifier, a highly stable variable-frequency oscillator may be obtained.

* * *