



# Development of Display Hardware Requirements for Surface Ship Bridge Integration

*Presented by*

**Adam Goetz**

*NSWCDD, Human Systems Integration Branch*

**JP Plummer, Taylor Shupsky, and John Winters**

*BCI, Dahlgren, VA*

---

**DoD Human Factors Engineering (HFE)  
Technical Advisory Group (TAG)  
Controls and Displays SubTAG**

---

May 2023

*The Leader in Warfare Systems Development and Integration*



NAVAL SURFACE WARFARE CENTER  
DAHLGREN DIVISION  
DAHLGREN | DAM NECK

- Bridge Lighting Assessment (BLA) effort developed in response to the 2017 Comprehensive Review of Recent Surface Force Incidents.
- Bridge system display hardware requirements were developed in support of the development, acquisition, and fielding of hardware that supports operational performance in low-light environments.
- Supporting operational performance includes balancing:
  - Needs for legible displays with adequate contrast.
  - Limiting overall brightness to facilitate dark-adapted vision.
  - Reducing overall ambient lighting in environment.
  - Ensure suitability across range of lighting conditions (including daytime operation).
- Current bridge equipment and system-specific requirements do not adequately support operational performance at night.



Light pollution in pilot house during night operations.

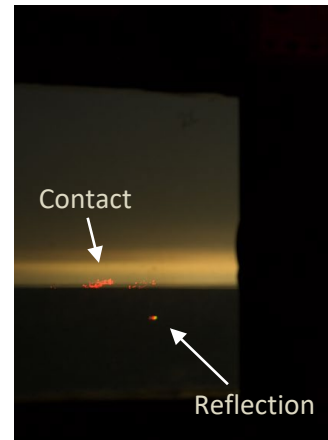

Contact vs. indicator reflection.

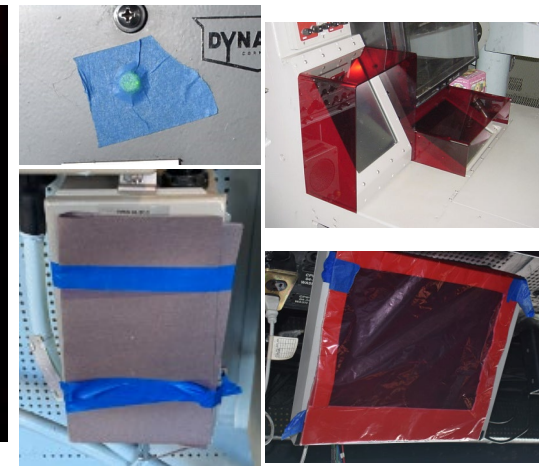

Example crew mitigations.

# Display Hardware Requirements Sources

- MIL-STD-1472 (*DoD Design Criteria: Human Engineering*) provides foundation for these requirements:
  - Ship Bridge Design section was established in MIL-STD-1472G Change 1 and carried forward to MIL-STD-1472H.
  - These requirements are characterized in terms of end-state operational performance.
    - E.g., display contrast requirements (5.2.1.3; 5.2.2.7) relate to actual display content and background and operational lighting conditions are assumed.
    - These need to be adapted without specific context for hardware acquisition and selection.
- MIL-STD-1472 requirements have been supplemented with:
  - Applicable documents, particularly from aviation.
  - Lessons learned from pier-side and underway shipboard observations and laboratory tests.
  - Naval aviation requirements and practices from the Naval Air Warfare Center Aircraft Division (NAWCAD) Aircraft Lighting and Transparency Lab (ALTL).

| Requirements Document  | Date               |
|--|--------------------|
| Aegis Computing Infrastructure (ACI) Prime Item Development Specification (PIDS), Thin Client Display (TCD) requirements (Dynamic Object Oriented Requirements System (DOORS) Requirements extraction) | Retrieved May 2021 |
| Aegis TCD Aydin Displays Functional Specification  | 11 February 2015   |
| IBNS Contract 3 Display Requirements, DDG Modernization Integrated Bridge and Navigation System (IBNS) Requirements Specification Revision: F  | 16 September 2019  |
| Next Generation Surface Search Radar (NGSSR) System/Subsystem Specification (SSS)  | 01 February 2018   |
| MIL-HDBK-516C Airworthiness Certification Criteria   | 12 December 2014   |
| MIL-HDBK-87213B Electronically/Optically Generated Airborne Displays   | 02 March 2020      |
| MIL-L-85762A Lighting, Aircraft, Interior, Night Vision Imaging System (NVIS) Compatible   | 26 August 1988     |
| MIL-STD-3009 Lighting, Aircraft, Night Vision Imaging System (NVIS) Compatible   | 02 February 2001   |
| MIL-STD-411F Aircrew Station Alerting Systems  | 10 March 1997      |

Display Hardware Requirements Sources.

Bridge System Display Hardware Requirements traced to MIL-STD-1472H Requirements:



Bridge Display Requirements

# Methodology for Display Testing

- All testing is completed in a dark environment (ambient light  $\leq .001$  lux).
- Specific methods are derived from various sources, including:
  - International Committee for Display Metrology's *Information Display Measurements Standard (IDMS)* (version 1.1)
  - International Organization for Standardization (ISO) 9241-300 series (*Ergonomic Design of Electronic Visual Displays*).
  - Various military documentation (e.g., MIL-HDBK-87213B).
  - Collaboration with NAWCAD ALTL for naval aviation procedures and practices.
- Most measurements use white or black 5×5 checkerboard test images.
  - Measurement take at the center of the display or at nine standard test points.
- Most measurements are taken orthogonal to the display (i.e.,  $90^\circ$  from display).

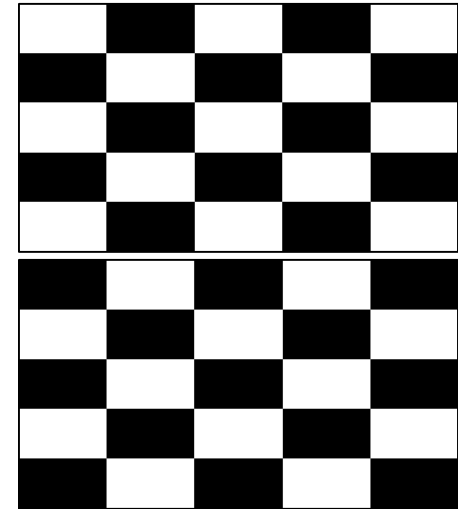

White (top) and Black (bottom) 5×5 checkerboard.

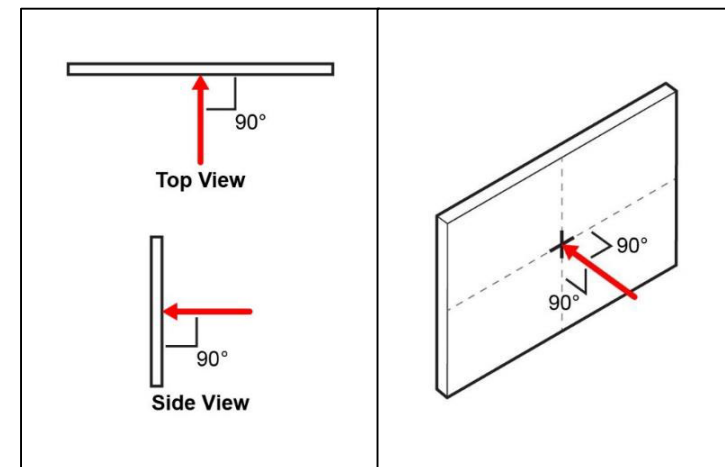

Orthogonal measurement.

# Methodology for Display Testing

- Off-axis measurements defined by direction and angle:
  - Direction refers to horizontal, vertical, or diagonal direction off the screen.
  - Angle refers to the angle from orthogonal in that direction.
- Off-axis measurements are collected at the edge of the viewing envelop.
  - If not defined:
    - Workstation displays:  $\pm 45^\circ$  off-axis vertically and horizontally.
    - Overhead displays:  $30^\circ$  up vertically,  $60^\circ$  down vertically, and  $\pm 60^\circ$  horizontally.
  - Additional angles are collected in  $15^\circ$  increments towards orthogonal, if possible.

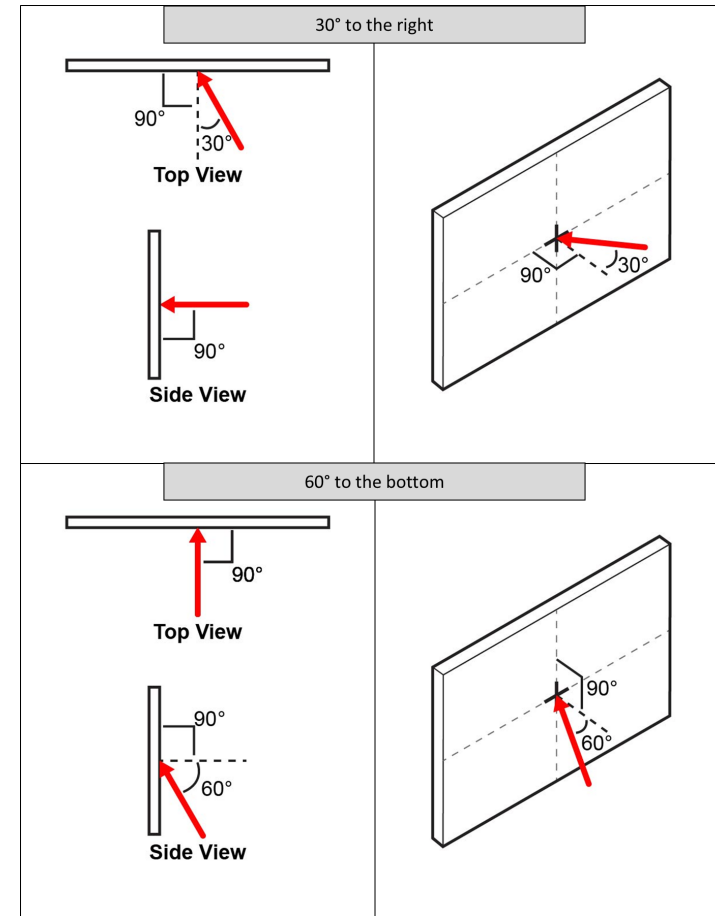

Examples of off-axis measurement angles and directions.

# 1. Minimum Display Luminance

The following requirements relate to the minimum luminance of a display for full white, as measured by a 5x5 checkerboard pattern:

|     |  |
|-----|--|
| 1.1 | Displays shall be dimmable to extinction (full off).   |
| 1.2 | Displays used solely by personnel not requiring dark adaptation shall be dimmable to a minimum full white luminance of 0.35 cd/m <sup>2</sup> or lower before extinction.<br><i>Modified from MIL-STD-1472 requirement of 3.5 cd/m<sup>2</sup>.<br/>Note: Minimum luminance should be measured at the center of the display with a white 5x5 checkerboard pattern.</i> |
| 1.3 | Displays used by personnel requiring dark adaptation shall be dimmable to a minimum full white luminance of 0.03 cd/m <sup>2</sup> or lower before extinction.<br><i>Note: Minimum luminance should be measured at the center of the display with a white 5x5 checkerboard pattern.</i>  |

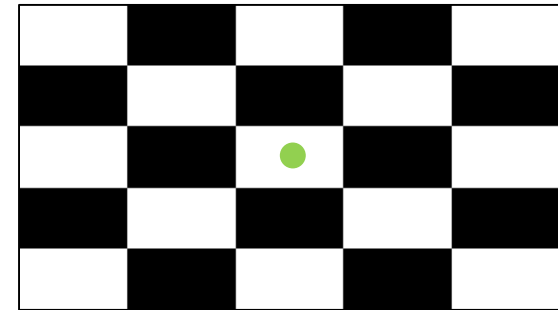

Minimum display requirements tested at center (green dot) of white 5x5 checkerboard.

The following requirement relates to the entire dimming curve, which prioritizes granularity at the lower end of the curve:

|     |  |
|-----|--|
| 1.4 | Displays shall exhibit an exponential luminance curve for all display brightness settings or modes (e.g., day, night). |
|-----|--|

**Notes:**

- The MIL-STD-1472 requirement for non-dark adapted positions was reduced to 0.35 cd/m<sup>2</sup> due to the excess ambient light produced at 3.5 cd/m<sup>2</sup>.

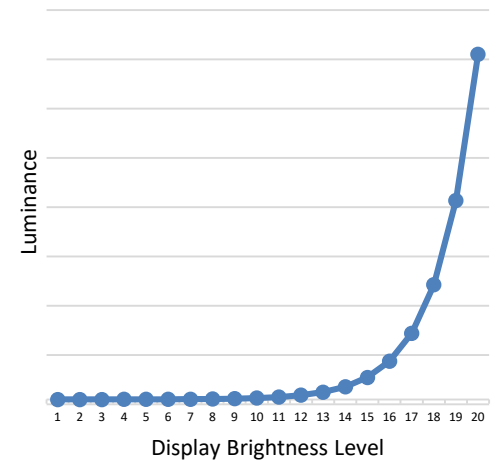

Example exponential curve with 20 levels.

# 1. Minimum Display Luminance

The following requirements relate display modes (e.g., day and night) that change the brightness range/capabilities of the display:

|       |  |  |
|-------|--|--|
| 1.5   | Displays should have operator-selectable display brightness modes, including for day and night.  |  |
| 1.6   | If brightness modes are present, they shall have the following characteristics:  |  |
|       | 1.6.1  | The maximum luminance for while in night mode shall be between 3.5 and 30.0 cd/m <sup>2</sup> .<br><i>Note: Maximum luminance should be measured at the center of the display with a white 5x5 checkerboard pattern.</i> |
|       | 1.6.2  | The minimum luminance for white in day mode shall be between 1.0 and 15.0 cd/m <sup>2</sup> .<br><i>Note: Minimum luminance should be measured at the center of the display with a white 5x5 checkerboard pattern.</i>   |
| 1.6.3 | The brightness modes shall have brightness levels for white that overlap.<br><i>Note: Luminance should be measured at the center of the display with a white 5x5 checkerboard pattern.</i> |  |

## Notes:

- MIL-HDBK-516C, Airworthiness Certification Criteria, was referenced for day/night mode transition points.
- Requirements related to the methods of adjustment between display modes are found in Section 6.

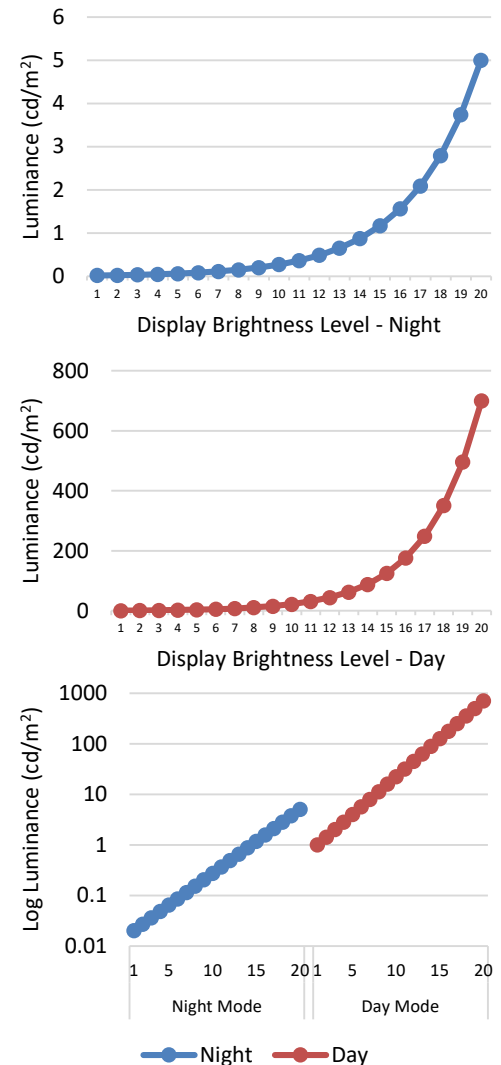

Example data illustrating night dimming curve (top), day dimming curve (middle), and overlap (bottom).

## 2. Maximum Display Luminance

The following requirements relate to the maximum luminance of a display for full white, as measured by a 5×5 checkerboard pattern:

|     |   |
|-----|---|
| 2.1 | <p>Displays exposed to direct sunlight (i.e., on the bridge wing or placed next to the pilot house windows) shall provide a maximum luminance of at least 700 cd/m<sup>2</sup> (204 fL) (objective) or 500 cd/m<sup>2</sup> (146 fL) (threshold).<br/><i>Note: Maximum luminance should be measured at the center of the display with a white 5×5 checkerboard pattern.</i></p> |
| 2.2 | <p>Displays shaded from direct sunlight (i.e., not placed next to pilot house windows) shall provide a maximum luminance of at least 340 cd/m<sup>2</sup> (100 fL).<br/><i>Note: Maximum luminance should be measured at the center of the display with a white 5×5 checkerboard pattern.</i></p>   |

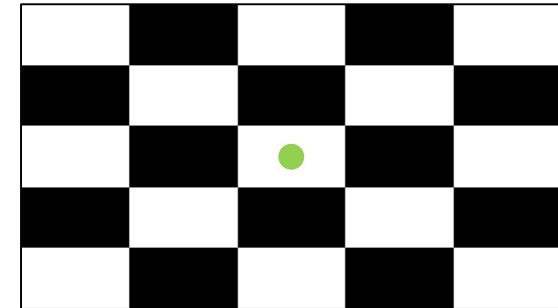

Maximum display requirements tested at center (green dot) of white 5×5 checkerboard.

### Notes:

- Direct sunlight requirements revised to match clear canopy and opaque overhead aviation luminance requirements (MIL-HDBK-516C, MIL-HDBK-87213B).
- If a particular display will be installed in multiple places or its installation placement is unknown, the objective value (e.g., requirement 2.1) should be used.
- For daylight readability concerns, requirements related to glare (Section 5) take precedence over these maximum luminance requirements.

# 3. Luminance and Chromaticity Uniformity

The following requirements relate to the luminance uniformity of full white and full black display content:

|         |  |  |
|---------|--|--|
| 3.1     | Displays shall meet the following luminance uniformity requirements both across its surface and over the expected range of operator viewing angles:<br><i>Note: Luminance uniformity should be measured at the nine standard test points with a white or black 5x5 checkerboard pattern.</i> |  |
| 3.1.1   | Displays shall exhibit no more than 30% luminance non-uniformity ( $1 - \min/\max$ ) for full white measured both at $1.0 \pm 0.1 \text{ cd/m}^2$ and at maximum day luminance for:  |  |
| 3.1.1.1 |  | All standard test points and observed hot spots measured orthogonally. |
| 3.1.1.2 |  | All standard test points for each off-axis measurement angle.          |
| 3.1.1.3 |  | Off-axis measurements at edge of viewing envelope for each test point. |
| 3.1.2   | Displays shall exhibit no more than a 50% luminance non-uniformity ( $1 - \min/\max$ ) for full black when the display is configured to show full white at $1.0 \pm 0.1 \text{ cd/m}^2$ and at maximum day luminance for:  |  |
| 3.1.2.1 |  | All standard test points and observed hot spots measured orthogonally. |
| 3.1.2.2 |  | All standard test points for each off-axis measurement angle.          |
| 3.1.2.3 |  | Off-axis measurements at edge of viewing envelope for each test point. |

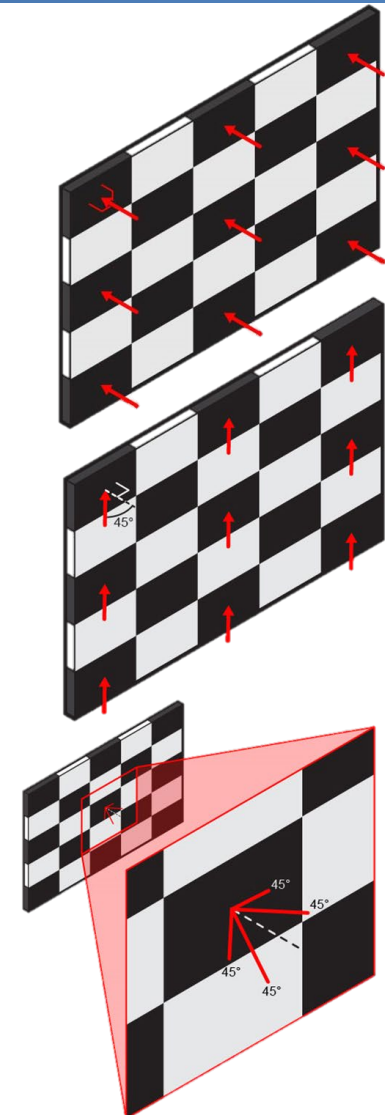

Example measurements of the three non-uniformity series.

# 3. Luminance and Chromaticity Uniformity

The following requirements relate to the stray light for white and black when viewed off axis:

|       |   |
|-------|---|
| 3.1   | Displays shall meet the following luminance uniformity requirements both across its surface and over the expected range of operator viewing angles:<br><i>Note: Luminance uniformity should be measured at the nine standard test points with a white or black 5x5 checkerboard pattern.</i>  |
| 3.1.3 | Displays shall exhibit no more than a 5% increase (objective) or 20% increase (threshold) in off-axis luminance measures compared to the orthogonal luminance level for both white and black luminance measured both for full white at $1.0 \pm 0.1 \text{ cd/m}^2$ . For black luminance, the photometer's absolute measurement error should be added to the orthogonal luminance level before calculating the allowable increase. |

## Notes:

- Stringent stray light requirements are included to minimize ambient light.
- The luminance non-uniformity requirements assess similarity in luminance across the display surface and across the anticipated viewing envelope.
  - They also guard against increased display luminance off the perpendicular, which leads to unwanted and excessive ambient illumination.
- Black luminance measures are likely to be low enough to require accommodation of photometric device measurement error. The ability to measure as low as  $0.001 \text{ cd/m}^2$  is assumed.

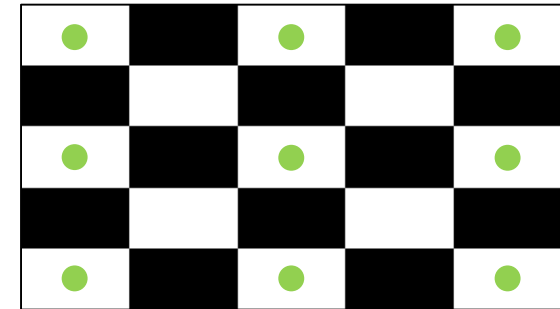

Non-uniformity measured from nine locations (green dots) on 5x5 checkerboard.

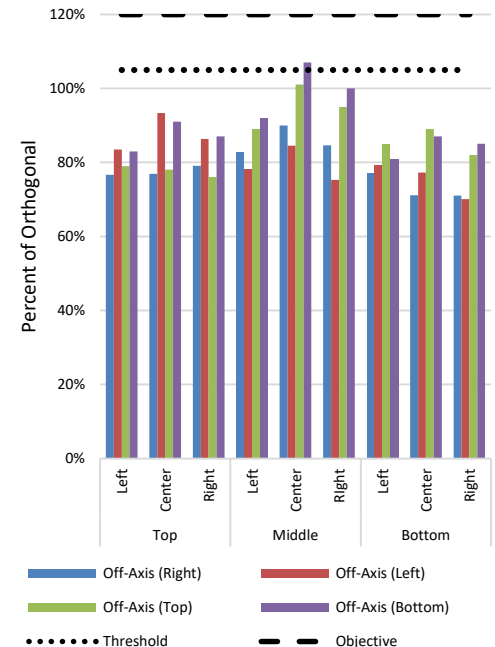

Example data output comparing percent of orthogonal at four off-axis measurements.

# 3. Luminance and Chromaticity Uniformity

The following requirements relate to the uniformity of color presentation on the display:

|       |  |
|-------|--|
| 3.2   | Displays shall provide color uniformity of $r$ less than 0.030 for fully-saturated red, green, and blue over the expected operator viewing envelope measured both at $1.0 \pm 0.1 \text{ cd/m}^2$ for white 5x5 test pattern and at maximum day luminance for:<br><i>Note: Chromaticity should be measured with red, green, and blue 5x5 checkerboard test images. <math>r</math> is the radius of the circular area around a reference point on the International Commission on Illumination (CIE) 1976 Uniform Color Space (UCS)</i> |
| 3.2.1 | All nine standard test points measured orthogonally (reference point = center of display).   |
| 3.2.2 | All off-axis measures across the expected range of operator viewing angles at the center of the display (reference point = orthogonal).  |

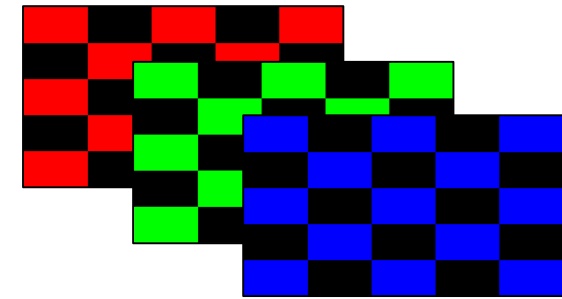

Red, Green, and Blue 5x5 checkerboard test images.

## Notes:

- Radius of 0.03 on the CIE 1976 UCS represents a just noticeable difference in color perception.
- Chromaticity uniformity is verified at both maximum day and a representative night settings.

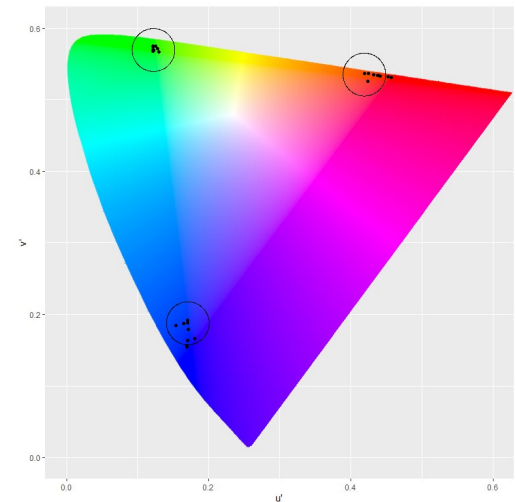

CIE 1976 UCS showing .03 radius around reference point for three colors.

# 4. Display Contrast

The following requirements relate to the maximum contrast of display content at specific display brightness settings:

|     |   |
|-----|---|
| 4.1 | Displays shall provide a white:black display contrast of 100:1 or greater for full white at 0.5 cd/m <sup>2</sup> .<br><i>Note: Contrast should be measured at the center of the display with a white or black 5x5 checkerboard pattern.</i>  |
| 4.2 | Displays shall provide a white:black display contrast of 50:1 or greater for off-axis measures across the expected range of operator viewing angles measured at 0.5 ±0.1 cd/m <sup>2</sup> or at 1.0 ±0.1 cd/m <sup>2</sup> .<br><i>Note: Contrast uniformity should be measured at the nine standard test points with a white or black 5x5 checkerboard pattern.</i> |

### Notes:

- ISO 9241-303 provides a minimum contrast requirement as a function of display luminance.
- Orthogonal display contrast (4.1) is tested at the center of the display with two different test images and then calculated.
- Off-axis contrast (4.2) is tested at the nine standard test points with two different test images, and guards against reduction in legibility across the viewing envelope.
  - The 50:1 requirement for off-axis contrast (4.2) allows for a 50% non-uniformity of contrast compared to the 100:1 orthogonal requirement (4.1) rather than compared to actual orthogonal contrast, which may exceed the 100:1 requirement.
  - Requiring off-axis contrast to be tested at either 0.5 or 1.0 cd/m<sup>2</sup> allows for this requirement to be tested without additional data collected beyond what is used for the non-uniformity requirements (Section 3).

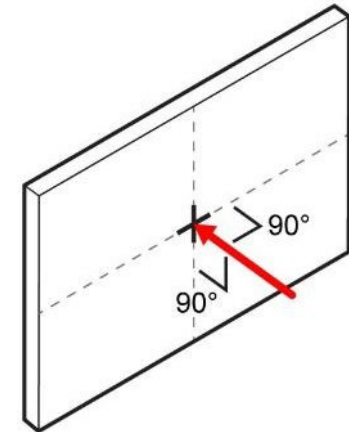

100:1 contrast requirement measured orthogonally.

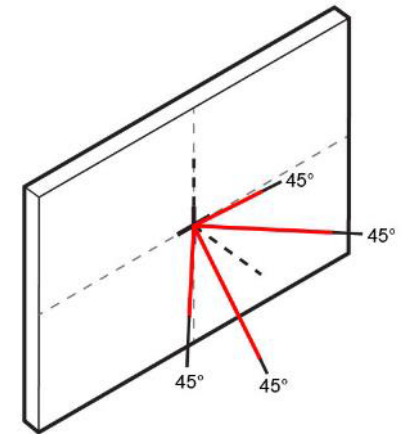

50:1 contrast requirement measured off-axis (e.g., 45°).

# 5. Glare

The following requirements relate the daylight readability under the maximum expected light environment, specular reflectivity, and diffuse reflectivity:

|       |   |  |
|-------|---|--|
| 5.1   | Displays shall meet the following requirements when measured in the applicable lighting condition defined in MIL-HDBK-87213B as modified in Table 6.  |  |
| 5.1.1 | Full white and full black display content shall have a High Ambient Daylight Contrast greater than or equal to the criteria defined in Table 7 in accordance with MIL-HDBK-87213B.  |  |
| 5.1.2 | Light from an external source creating a specular reflection on a display shall not exceed 1.0 percent of the display luminance for a viewing angle of 30 degrees or less from the display normal or across the expected range of operator viewing angles, whichever is larger. |  |
| 5.1.3 | Light from an external source creating a diffuse reflection on a display shall not exceed 0.2 percent for a viewing angle of 30 degrees or less from the display normal or across the expected range of operator viewing angles, whichever is larger.                           |  |

**Notes:**

- This method adapts methods specified in MIL-HDBK-87213B for cockpit displays to assess bridge displays.
- If a display does not meet these requirements, operational assessment of daylight readability can be conducted with operationally-relevant display content.

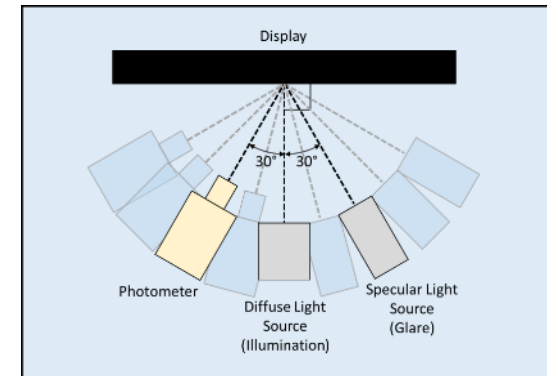

Equipment arrangement for glare testing.

| Bridge Location                    | MIL-HDBK-87213B Environment | Diffuse Illumination (Sunlight) | Glare Source (Specular)          |
|------------------------------------|-----------------------------|---------------------------------|----------------------------------|
| Bridge Wings                       | Bubble Canopy               | 108,000 lux (10,000 fc)         | 6800 cd/m <sup>2</sup> (2000 fL) |
| Above or Below Pilot House Windows | Cockpit with Roof           | 86,000 lux (8,000 fc)           | 6800 cd/m <sup>2</sup> (2000 fL) |
| Pilot House Interior               | Shaded                      | 3240 lux (300 fc)               | 6800 cd/m <sup>2</sup> (2000 fL) |

Table 6 – Bridge Display Lighting Conditions

| Display Content   | MIL-HDBK-87213B Category          | Required Contrast |
|---|-----------------------------------|-------------------|
| Automated Status Boards (ASTABs)                                  | Alphanumerics                     | ≥ 2.0             |
| Steering and Propulsion Control; Hull, Mechanical, and Electrical | Graphic Symbols and Alphanumerics | ≥ 3.0             |
| Radar Displays, Navigational Charts, External Video               | Video, Worst Case                 | ≥ 4.66            |

Table 7 – Bridge Display High Ambient Daylight Contrast Criteria

# 6. Brightness Controls

The following requirements relate to the controls for the brightness level on the display:

|     |   |
|-----|---|
| 6.1 | The display shall provide an external control for the full range of brightness adjustment.  |
| 6.2 | Display brightness controls should provide continuous control over an exponential curve for luminance within each display mode.   |
| 6.3 | Displays with incremental brightness controls shall provide a minimum of twenty exponential luminance settings within each display mode.  |
| 6.4 | Displays with separate display modes (e.g., day and night) shall require operator confirmation when switching from night to day mode (objective) or shall ensure that the display remains at or below the night mode maximum brightness level when switching from night mode to day mode (threshold). |
| 6.5 | Controls for display and indicator or control luminance adjustment shall allow both increasing and decreasing adjustments of brightness.  |
| 6.6 | The display shall provide the user with the capability to locate and identify brightness controls by tactile means throughout the entire range of display brightness, including at extinction.<br><i>Note: Use of a knob is preferred over use of buttons.</i>  |
| 6.7 | Brightness controls should be single-function controls and shall not control any additional functions other than display power.   |
| 6.8 | If an on-screen scale or indicator of display brightness is provided, then it shall dim relative to overall display brightness.   |
| 6.9 | Controls for display and indicator or control luminance adjustment shall adjust luminance for each discrete control input.  |

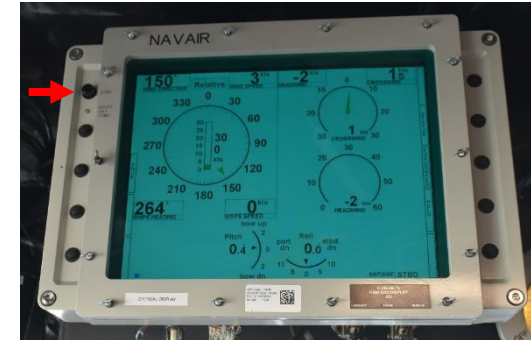

Example brightness controls: knob (top); bidirectional buttons (middle); unidirectional button (bottom).

# 7. Indicators and Backlit Controls

The following requirements relate to bezel-mounted indicator lights and backlit controls:

|     |  |
|-----|--|
| 7.1 | Bezel-mounted indicator lights and backlit controls shall be dimmable at night to 1.0 cd/m <sup>2</sup> or less.   |
| 7.2 | Bezel-mounted indicator lights and backlit controls shall have a luminance ratio of no greater than 2:1 between the brightest and dimmest bezel components at any given display luminance level. |

The following requirements relate to other indicators or light sources on the display:

|     |  |
|-----|--|
| 7.3 | Indicators and light sources internal to the display housing shall not create light leakage through air vents or other openings. |
| 7.4 | Non-dimmable indicator lights should not be visible from the anticipated operator viewing positions.                             |
| 7.5 | Non-dimmable indicator lights should have a luminance no higher than 1.0 cd/m <sup>2</sup> [TBR] in any direction.               |
| 7.6 | Non-dimmable labelled indicators should have a luminance no higher than 0.5 cd/m <sup>2</sup> [TBR] in any direction.            |



Examples of bezel-mounted indicator lights and backlit controls.

# Discussion and Path Forward

- Current requirements support bridge hardware acquisition and selection.
  - Displays that meet the requirements will support operational performance under all lighting conditions expected on the bridge.
  - These requirements have been used to evaluate prototype displays in the lab and drive changes.
- Future focus areas:
  - Indicators.
    - This will involve underway validation of the current requirements.
    - Specific focus areas for indicators include:
      - Display bezel vs. standalone indicators.
      - Large (e.g., labelled) vs. small indicators.
      - Day vs. night use/requirements.
  - Peripheral equipment.
    - Specifically addressing backlights of keyboards and trackballs.

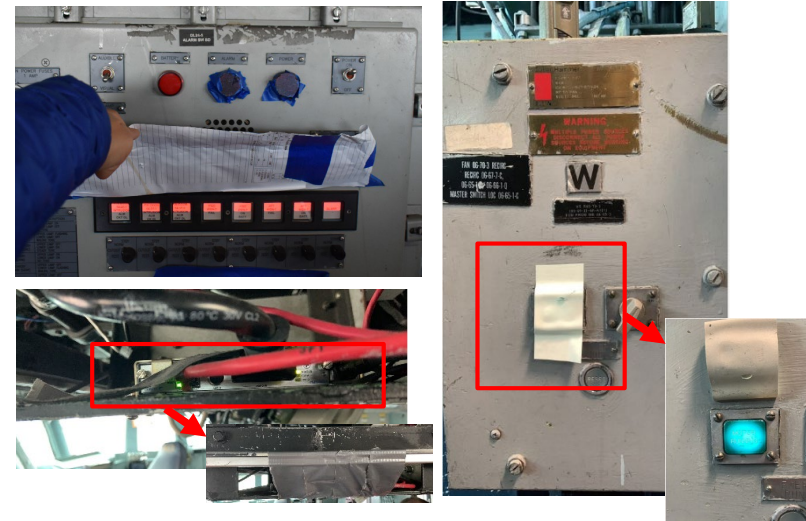

Example large, small, and labelled indicator lights with crew mitigations.



Example backlit keyboard and trackball.