

UNCLASSIFIED

DECLASSIFIED

2020

NRL REPORT 3784

FR 3784

TECHNIQUES FOR ELECTRONIC CONTROL OF UHF OSCILLATORS

DECLASSIFIED by NRL Contract
Declassification Team
Date: 30 JAN 2017
Reviewer's name(s): ~~XXXXXXXXXX~~
~~XXXXXXXXXX~~
Declassification authority: NAVY DECLASS
GUIDE / NAVY DECLASS MANUAL, 11 DEC 2012

DECLASSIFIED by authority of
1505-358/54
Date 4 May 1954
Entered by E. Bliss
NRL Code 4027



NAVAL RESEARCH LABORATORY

WASHINGTON, D.C.

DISTRIBUTION STATEMENT A APPLIES
Further distribution authorized by _____
UNLIMITED only.

UNCLASSIFIED

DECLASSIFIED

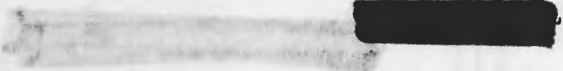

DISTRIBUTION

OpNav Attn: Code Op-42B2	1
BuShips Attn: Code 834	10
ONR Attn: Code 470	1
CO, ONR, Boston	1
CO & Dir., USNEL	2
CDR, USNOTS Attn: Reports Unit	2
Supt., USNPGS	1
CDR, NATC, Patuxent River, Md. Attn: Electronics Test	1
CDR, NADC, Johnsville, Pa.	1
Wright-Patterson AFB Attn: BAU-CADO	1
Attn: CADO-E1	2
Attn: Ch., Electronics Subdiv., MCREEO-2	1
Chief of Staff, USAF Attn: ANDRE-2G	1
CO, Watson Labs., AMC, Red Bank Attn: WLENG	2
Attn: ENR	1
CO, Air Force Cambridge Res. Labs Attn: WLCRD	2
Attn: ERRS	1
OCSigO Attn: Ch. Eng. & Tech. Div., SIGTM-S	1
CG, SCEL Attn: SCEL Liaison Office	3

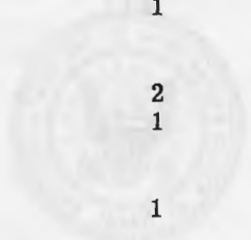

CONTENTS

Abstract vi

Problem Status vi

Authorization vi

INTRODUCTION 1

DESIGN REQUIREMENTS 1

EXPERIMENTAL CIRCUITS 1

 Barkhausen Oscillator 1

 Transit-Time Control 2

 Reactance-Tube Control 3

PROPOSED ELECTRON-BEAM CONTROL CIRCUIT 4

CONCLUSIONS 6

DECLASSIFIED

ABSTRACT

Circuit techniques are described which provide for electronic tuning of several megacycles of radio-frequency generators operating in portions of the 200-400 Mc frequency range. A circuit which provides uniform electronic tuning of about 4 Mc throughout a tuning range from 250 to 350 Mc has been devised. Efforts to extend the operation to a tuning range from 225 to 430 Mc have not been successful.

PROBLEM STATUS

This is a final report on one phase of the problem; work is continuing on other phases.

AUTHORIZATION

NRL Problem R01-05D (BuShips Problem No. S767.1)
NE 020-237

DECLASSIFIED

DECLASSIFIED

UNCLASSIFIED

TECHNIQUES FOR ELECTRONIC CONTROL OF UHF OSCILLATORS

INTRODUCTION

Problem 39R01-05D is concerned with development of multichannel radio-communication equipment operating in the 200-400 Mc frequency range. The equipment in use at present is susceptible to spurious interference, both radiated and received. This condition results from radio-frequency multipliers used to obtain the final operating frequency from the controlled master oscillator. If some means were devised to generate and control the final frequency directly, then the multipliers could be eliminated and, as a consequence, the susceptibility to spurious interference would be reduced.

DESIGN REQUIREMENTS

A circuit with the following characteristics is needed to generate and control the final frequency.

1. It must be capable of continuous oscillation throughout a tuning range from 225 to 400 Mc.
2. Provision should be made for an electronic tuning of at least ± 2 Mc that is uniform throughout the oscillator tuning range.
3. The electronic tuning should not vary the oscillator power output.
4. The oscillator should have sufficient power to drive a receiver-mixer stage or a transmitter power amplifier.
5. The circuit elements should be light, small, and stable under service conditions.

The desired requirements are fulfilled, in general, by klystron oscillators. Unfortunately, klystrons are not practical for operation at frequencies below 600 Mc nor for operation over such large tuning ranges. The problem has been solved for frequencies below 30 Mc by reactance tubes, but again the circuit is not directly applicable to the 200-400 Mc range. This arises from the fact that at higher frequencies the tube interelectrode capacities have such low reactance that a phase-shifting network is shunted by the capacities, and sufficient quadrature voltage cannot be formed between grid and cathode.

EXPERIMENTAL CIRCUITS

Barkhausen Oscillator

In an attempt to find a suitable circuit for electronic tuning, the circuit of Figure 1 was tried. The plate of a 6AG7 was connected to a source of negative bias variable between 0 and -100 volts. A tuned circuit was connected between the screen and suppressor elements, and the control grid was fixed biased slightly negative, and by-passed to the cathode.

DECLASSIFIED

It was found that the circuit oscillated throughout a tuning range of from 180 to 250 Mc. The plate potential was effective in changing the operating frequency, and did not vary the power output severely. Rough calculations of transit time seemed to indicate that electrons travelled through the screen-suppressor field into the retarding plate-suppressor area and returned to the screen or suppressor much the same as in a reflex klystron. The screen and suppressor voltages had to be increased with increasing frequency and an increase in negative bias on the plate resulted in a higher frequency. Later experiments proved the circuit to be a form of Barkhausen oscillator.

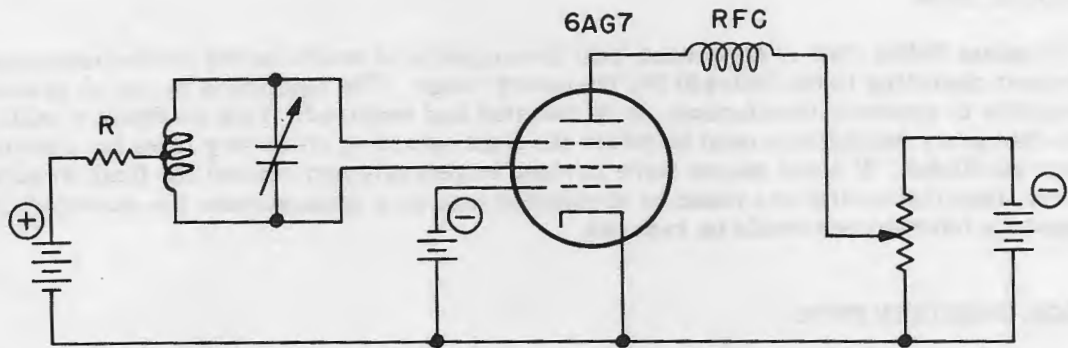

Figure 1 - Barkhausen oscillator

The circuit was abandoned because the frequency of oscillation was primarily dependent upon the tube-element spacings and a wide tuning range could not be secured. Other disadvantages are the dependence of element voltages upon frequency, the very poor efficiency, and the lack of deviation uniformity with operating frequency.

Transit-Time Control

Another circuit investigated employed the transit time of electrons returning from a negative plate to the screen of a pentode or tetrode. This circuit is shown in Figure 2. The oscillator circuit was formed between control grid and screen grid of a pentode and the screen grid served as plate of the oscillator. The electrons which passed through the screen grid entered a negative field, and were returned to the screen. The transit time of the electrons was adjusted to return them to the screen 90 electrical degrees later and cause the screen to draw a reactive current.

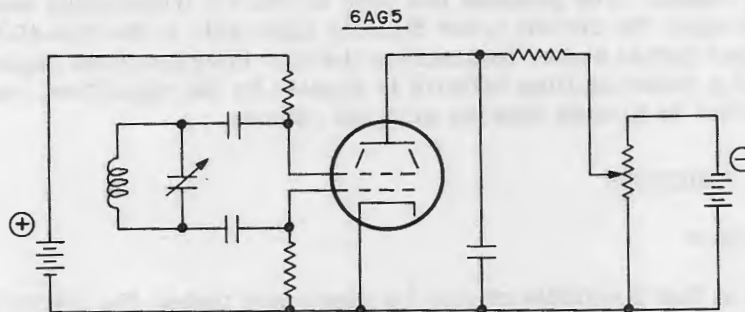

Figure 2 - Transit-time control

The operation of the circuit was not satisfactory. The screen and plate voltages were very critical and dependent upon operating frequency. The best result achieved was a deviation of 3 Mc with a tuning range from 260 to 360 Mc. Operation above 300 Mc was spotty and there was a tendency for the oscillator to jump into Barkhausen oscillations.

Reactance-Tube Control

The circuit shown in Figure 3 was found to perform well when used with some restrictions. In this circuit, both sections of a type 6J6 tube are used. One section is used as an oscillator tuned by a sliding contact on an open-wire transmission line, and the other section as a reactance tube. The cathode is common to both sections and the plates are connected together. The complete phase shift network is formed from the tube lead inductance, an external resistance, and the tube interelectrode capacities. The equivalent circuit of the phase-shift network is shown in Figure 4. The inductance of the plate lead of the oscillator section is considered part of the transmission line. The cathode is common, and inductance between sections is neglected. The inductance between grid and cathode is formed by the grid lead and the cathode lead. The inductance between the reactance tube and the tank circuit is the plate lead inductance. The capacities are the grid-to-plate and the grid-to-cathode interelectrode capacities. The capacity between sections has been neglected. Rough calculations of the network gave the following results. For frequencies around 200 Mc, the phase shift was nearly 90°; for 300 Mc, 80°; and for 400 Mc, only 50°. The calculations predicted good operation for frequencies between 200 and 300 Mc.

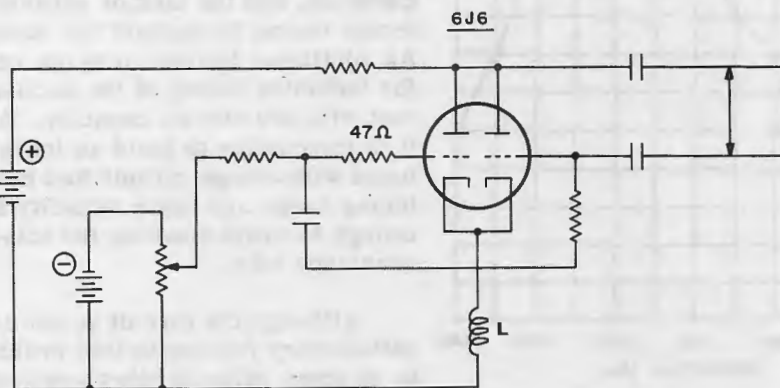

Figure 3 - Reactance-tube control

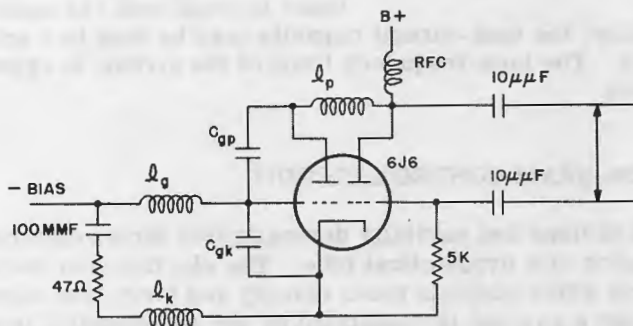

Figure 4 - Equivalent circuit

C [REDACTED]

The phase-shifted voltage on the grid of the reactance section causes the tube to draw a reactive current, which may be controlled by the bias. This variable reactance is formed between plate and cathode of the oscillator section instead of across the tuned circuit as in conventional low-frequency practice. This arrangement permits using a common cathode and filament, and eliminates having to isolate these elements as in conventional circuits. Since the variable capacity is between plate and cathode of the oscillator tube, it is effectively in series with the grid-to-cathode capacity and the series combination is in parallel with the tank-circuit capacity. This means that the actual capacity change is very small, and if wide deviations are desired the tank capacity must be kept small. Furthermore, in order to keep the deviation reasonably constant, the oscillator must be tuned by varying inductance.

Figure 5 is a graph of frequency deviation vs. oscillator frequency. The frequency deviation is nearly constant at 8 Mc for oscillation frequencies from 250 to 400 Mc. Above 400 Mc the deviation falls off because of the lack of 90° phase shift through the network. In addition, the lack of quadrature voltage on the grid of the reactance tube causes the tube to draw a resistive current which loads the oscillator. The resistive current stops oscillations for frequencies above 430 Mc. The low-frequency deviation falls off owing to the increase in capacity of the tuning circuit and the decrease in voltage feed to the reactance-tube grid.

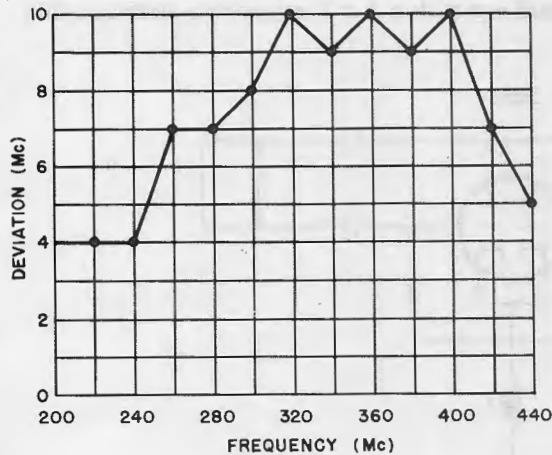

Figure 5 - Deviation vs. oscillator frequency reactance-tube control

fixed-frequency operation, the tank-circuit capacity may be kept to a minimum and deviations of 8 Mc expected. The high-frequency limit of the circuit is approximately 400 Mc and the low limit 250 Mc.

The circuit falls short of the desired characteristics because of the change in power output of the oscillator at high frequencies, and the lack of sufficient electronic tuning throughout the tuning range. An additional limitation is the requirement for inductive tuning of the oscillator circuit with low circuit capacity. At present it is impossible to build an inductively tuned wide-range circuit that covers the tuning range and has a capacity small enough to avoid masking the effect of the reactance tube.

Although the circuit is not completely satisfactory for use in this problem, it may be of some value in other applications. Electronic deviations of 4 Mc are readily obtained in the frequency range from 250 to 350 Mc if a low-capacity, variable-inductance tuner is employed. In applications requiring

PROPOSED ELECTRON-BEAM CONTROL CIRCUIT

A theory has been devised and partially demonstrated for an electron-beam reactance tube. Figure 6 is a sketch of a hypothetical tube. The electron gun includes a control grid and an accelerating grid which controls beam density and forms the electrons into a beam. The beam passes through a gap and is modulated by the r-f potential impressed across the gap. The electrons pass into a drift space and form bunches in similarity to the action in

a reflex klystron. The reflector, however, instead of focusing the electron bunches back through the gap, allows the bunches to spread and hence hit the second grid of the gap. The transit time of the bunched electrons is adjusted so as to return the bunches to draw a reactive current. The magnitude of the reactive current is controlled by the beam-current intensity, and the drift time by the reflector potential.

A Western Electric Type 707-A reflex klystron tube is the nearest approximation to the hypothetical tube. The circuit in Figure 7 was used to demonstrate the principles in the preceding analysis. Since the spacings between gap grids and between gap and reflector are much too small for the 200 to 400 Mc frequencies, the beam was adjusted to return to the gap in one quarter cycle rather than a desired drift time of several cycles. This limitation considerably reduced the extent to which bunches are formed and therefore reduced the reactive current.

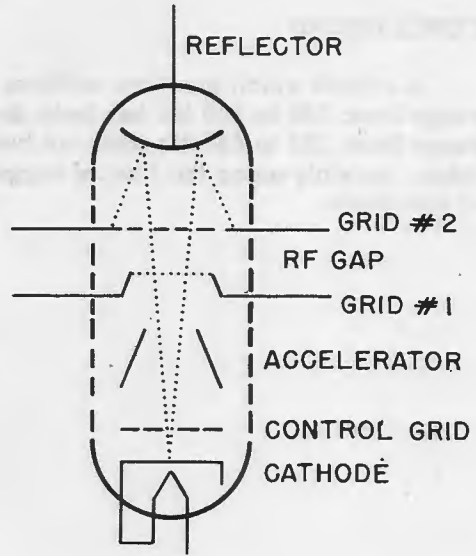

Figure 6 - Proposed electron-beam control tube

The results of the test are encouraging. The electrical deviation was found to be 5 Mc throughout the tuning range from 200 to 360 Mc. It is believed that a tube designed for reactance tuning would perform considerably better. The disadvantage of transit-time reactance control is that the reflector potential must be adjusted with frequency. This is a serious limitation in a wide-tuning-range circuit as it requires a potentiometer to be ganged and tracked with the tuning of the driving oscillator. The advantages of the control are: first, the reactance has little resistive component; second, the electrodes requiring adjustment do not draw current; and third, the r-f gap has very small capacity and does not appreciably shunt the oscillator.

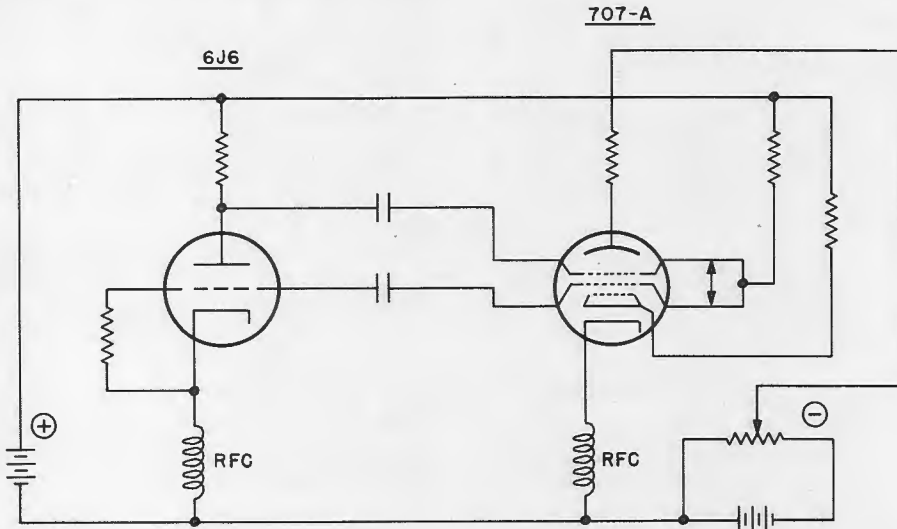

Figure 7 - Electron-beam control

CONCLUSIONS

A circuit which provides uniform electronic tuning of about 4 Mc throughout a tuning range from 250 to 350 Mc has been devised. Efforts to extend the operation to a tuning range from 225 to 430 Mc have not been successful. The design and construction of special tubes, possibly along the line as suggested in this report, is necessary to extend the range of operation.



The circuit of the test set is shown in Figure 1. The circuit is a simple electronic circuit consisting of a power supply, a tuning coil, and a detector. The power supply is connected to the tuning coil, which is in turn connected to the detector. The detector is a vacuum tube that provides the electronic tuning. The circuit is designed to provide uniform electronic tuning of about 4 Mc throughout a tuning range from 250 to 350 Mc.

