

# ENCODING VERIFICATION ARGUMENTS TO ANALYZE HIGH-LEVEL DESIGN CERTIFICATION CLAIMS: EXPERIMENT ZERO (E0)

*Dionisio de Niz*

*Bjorn Andersson*

*Mark Klein*

*John Lehoczky (Carnegie Mellon University)*

*Hyoseung Kim (University of California, Riverside)*

*George Romanski (Federal Aviation Administration)*

*Jonathan Preston (Lockheed Martin Corporation)*

*Daniel Shapiro (Institute of Defense Analysis)*

*Floyd Fazi (Lockheed Martin Corporation)*

*Douglass C. Schmidt (Vanderbilt University)*

*David Tate (Institute of Defense Analysis)*

*Gordon Putsche (The Boeing Company)*

*Ron Koontz (The Boeing Company)*

January 2024

[DISTRIBUTION STATEMENT A] This material has been approved for public release and unlimited distribution.

---

## Introduction

The ASERT (Assurance Evidence for Continuously-Evolving Real-Time Systems) workgroup (ASERTW) has been investigating alternative technologies and techniques to automate certification. ASERTW's first step was captured in a report that identifies the state of the practice and future challenges, especially the need to speed up the pace of updates to cyber-physical systems (CPSs) [ASERTW 2022].

The second step is what we call Experiment Zero (E0). The goal of this experiment is to test technique(s) to verify if the automation of certification arguments can help us to explain potential design/development flaws related to real-world reported problems. To conduct this experiment, we used a recent flight incident report published by the Taiwan Transportation Safety Board [TTSB 2021]. Based on this report, we developed some theories of potential design shortcomings that could explain the sequence of events in this incident. Given the limited information obtained from the incident report, it is important to note that this paper does not claim that such shortcomings necessarily existed. Instead, we view this incident as a way to evaluate if and how formalizing and automating arguments can validate designs and find shortcomings if they exist.

## Argument-Driven Development

A key principle of extreme programming, which is part of the Agile development movement, is test-driven development (TDD). The main goal of TDD is to improve the quality of software by transforming software requirements into test cases; this is also called test-first programming. We

believe that TDD is a powerful principle but, as we will see in this report, code is insufficient to evaluate the requirements of a CPS. In particular, code by itself lacks information to evaluate critical properties of a CPS.

For example, consider evaluating the completion time of the execution of a function to inflate the airbag of a car. This evaluation requires determining how long it would take the software to execute, but such information is not explicitly defined in the code. Instead, this information is the combination of many factors, such as the instructions the processor needs to execute, the speed of the processor, the other tasks running on the same processor, and the scheduler(s) used. Similarly, calculating the probability of failure of a function includes the probability of failure of the processor it runs in, the dependency with other functions, power supply dependencies, etc.

Code is actually not necessary to validate early design decisions that can be catastrophic and costly if these decisions are incorrect. A number of design analysis methods can be applied to early design models even before we have code. These methods allow us to identify design flaws, find assumption conflicts, perform early tradeoff analysis, etc. Moreover, these methods can be an integral part of the strategies to certify CPSs. Specifically, these methods can be included in verification plans to verify certification claims that are presented to a certifier. If the plan meets the certifier's criteria, it is approved, and the developer (or independent verification organization) proceeds to execute the plan by applying the verification methods (and other verification procedures) to obtain evidence to prove the claims.

Since certification claims can be complex and may need different verification procedures to prove them, they can be decomposed into a number of subclaims. This decomposition can be done with different degrees of formality. For example, they can be described in plain English discussing how a claim can be decomposed into subclaims or described in a more structured format using assurance cases. Assurance cases use arguments to decompose claims into subclaims and connect them to evidence to prove subclaims.

In assurance cases, argumentation is designed for human execution and hence can suffer from scalability issues and multiple interpretations of the same claims by different people. This paper avoids these human-centered problems by exploring a technique to formalize assurance arguments and using formal verification tools to automate their processing. This technique both removes human interpretation and increases processing scalability through automation.

Inspired by the test-driven development—but targeting the certification of CPS—we propose the use of an argument-driven development where a certification plan is created to determine the key claims that must be satisfied by the final CPS. These claims then can be captured into executable arguments and decomposed into subclaims that are subsequently evaluated using automated analysis methods applied to the design models that drive the development. Next, these models can be refined, leading all the way down to implementation code, ensuring that early verification is not invalidated and that the assumptions between different methods do not contradict each other.

We believe the full automation of certification arguments can make systems safer and enable faster assured updates as modifications can be evaluated against modifications to argumentation early on,

and only the parts of the arguments that are modified require recertification. Moreover, it is possible to identify flaws in our arguments in systems already deployed. The lessons learned from such events can then be incorporated into machine-processable arguments that can be reused in further certifications so that these lessons are not forgotten.

## State of the Art

This paper shares some objectives with [Shankar 2022]. In particular, they promote the concept of assurance-based development that is similar to the concepts we present here. However, their focus is on the final system; hence, they focus on the application of verification tools to the final system. In contrast, we focus on a more comprehensive approach that encompasses early designs and higher levels of abstractions where arguments can be developed and verified much earlier. Moreover, the low-level focus closer to the code forces abstractions that remove aspects from other analysis domains (e.g., timing, fault tolerance) thereby creating blind spots for conflicts in analysis assumptions from these domains.

The techniques we use are presented in [de Niz 2023], which is based on *analysis contracts* that describe what an analysis tries to prove, what assumptions it makes, and how it connects to a full argument developed to prove verification claims. Analysis contracts rely on assume/guarantee reasoning based on Hoare triples [Hoare 1969], which evolved into more abstract domains with the development of contract algebras [Benveniste 2018]. Contracts have also been used in assume/guarantee reasoning over components in the Architecture Analysis and Design Language (AADL) [SAE 2009, Cofer 2012]. However, component contracts reason about properties of the values that AADL components communicate through their ports to other components and the computation that occurs inside a component that transforms input values into output values. This approach is a more traditional way of thinking about contracts that is easier to map to a Hoare triple. In contrast, analysis contracts reason about properties of analysis algorithms applied to models (e.g., AADL models), not the computations inside the components of the model. Our goal is to reason about how multiple analyses work together to prove top-level assurance claims instead of how properties on values generated by model components discharge properties of top-level components. From this point of view, therefore, an analysis that uses component contracts to verify value transformation properties is just another analysis that we integrate and that would have its own analysis contract.

Previous work in analyses contract started with [Nam 2011], where contracts were defined for resource allocation models. These contracts were defined in Alloy [Jackson 2019], and the analyses algorithms were implemented in Mathematica and included in the AADL models. Analyses contracts were later extended [Ruchkin 2014] to remove the bounded verification limitations of Alloy, implementing the contracts specification with a mixture of satisfiability modulo theories (SMT) and linear-time temporal logic (LTL) [Kesten 1998] with a verification in Z3 and SPIN [Holzmann 1997]. This work also extended the analyses beyond resource allocation to other domains, such as thermal dissipation and security. Later, the authors in [Brau 2018] created an implementation of analysis contracts with a special emphasis on lower level analysis assumptions within the same domain.

In [Wang 2022], the authors present a contract model close to analysis contracts with a synthesis approach to combine multiple contracts that restrict the design space out of pre-crafted parts. Their approach works at a more abstract level closer to [Benveniste 2018]. It is applied at the assurance case level and reuse of assurance case patterns but provides no connection to domain-specific analysis algorithms.

Given the focus on using tools for analysis, it is natural to ask whether to trust that the output of the analysis was computed correctly. The recently coined term *explainable verification* focuses on addressing this issue [ERSA 2022, ERSA 2023]. This effort focuses on the approach that an analysis not only needs to compute an output but also an explanation of why it produced this output. This explanation must then be easy to consume by a person without requiring deep expertise in the analysis domain.

## A Flight Incident Case

As stated in [TTSB 2021],

*On June 14, 2020, China Airlines scheduled passenger flight CI202, an Airbus A330-302 aircraft, registration B-18302, took off from Shanghai Pudong International Airport for Taipei Songshan Airport with 2 flight crew members, 9 cabin crew members, and 87 passengers, for a total 98 persons onboard. The aircraft landed on runway 10 of Songshan Airport at 17:46 Taipei local time. At touchdown, the aircraft experienced the quasi-simultaneous failure of the 3 flight control primary computers (FCPC or PRIM), thus ground spoilers, thrust reversers, and autobrake were lost. The flight crew was aware of the autobrake and reversers failure to activate, and applied full manual brake rapidly to safely stop the aircraft about 30 feet before the end of runway 10 without any damage to the aircraft nor injuries to the passengers onboard.*

A partial view of the A330 architecture is depicted in Figure 1, extracted from [TTSB 2021].

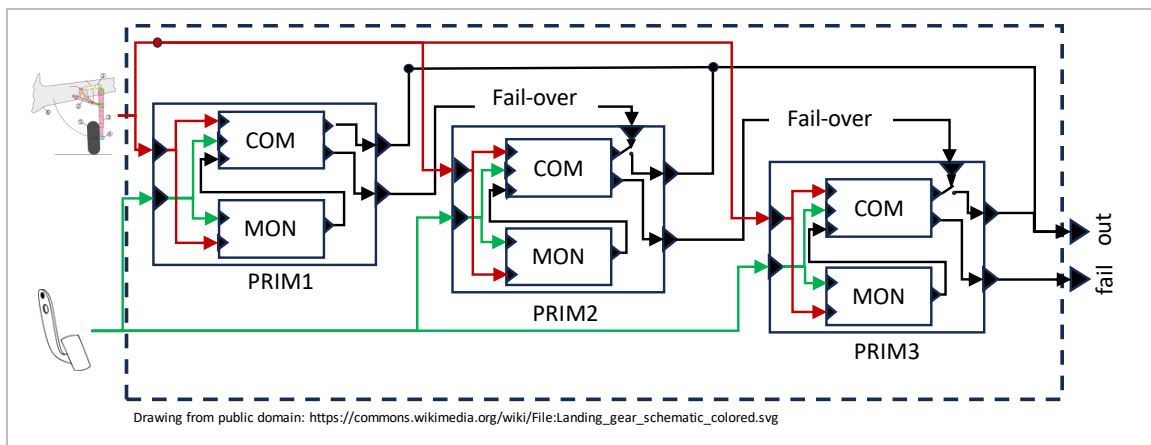

Figure 1: Airbus A330 Flight Control Architecture

More specifically, each PRIM computer is composed of a main command processor (COM) (part of a sequence of processors or channels as known in aviation) and a monitor processor (MON). Both calculate the same actuation value according to the pilot input (depicted by a pedal in the figure). Then COM receives the computed value from MON and compares it to its own value. If the difference is within a threshold, it uses its output. In contrast, if it exceeds the threshold, it fails-over to the next PRIM computer arranged in the same fashion. The next PRIM computer performs the same comparison and has the same failover strategy. If PRIM3 also fails, backup computers are activated.

It is important to note that these computers execute different functions when the aircraft is in air mode versus when it is in ground mode. This is because in air mode, control surfaces are actuated; in ground mode, the landing gear wheels are actuated.

## Key Sequence of Events

In the incident report, the following sequence of events was identified as significant:

1. Gear touchdown → Aircraft switch to ground mode
2. Gear in the Air → Aircraft switch to air mode
3. Gear touchdown → Aircraft switch to ground mode
4. PRIM1 Failed-over
5. PRIM2 Failed-over
6. PRIM3 Failed-over

The report also identified that the cause of the failure stemmed from the disagreement between the COM and the MON over the actuation in [TTSB 2021, p. 68]. This disagreement was traced back to the computation of different functions (controls laws) by COM and MON due to the switching between air mode and ground mode. More specifically, one of the channels<sup>1</sup> used the “lateral flight control law” to calculate the rudder command (based on the pilot pedal input), while the other used the “lateral ground law,” exceeding the threshold that was designed to compare differences for the same law [TTSB 2021, p. 6]. This disagreement was called *channel asynchronism*.

## Channel Asynchronism Timeline

Based on the information presented above we created a sample timeline that could explain the triple failure, which is shown in Figure 2.

---

<sup>1</sup> In Avionics, an end-to-end computation from sensor to actuator that is replicated is typically referred to as a channel.

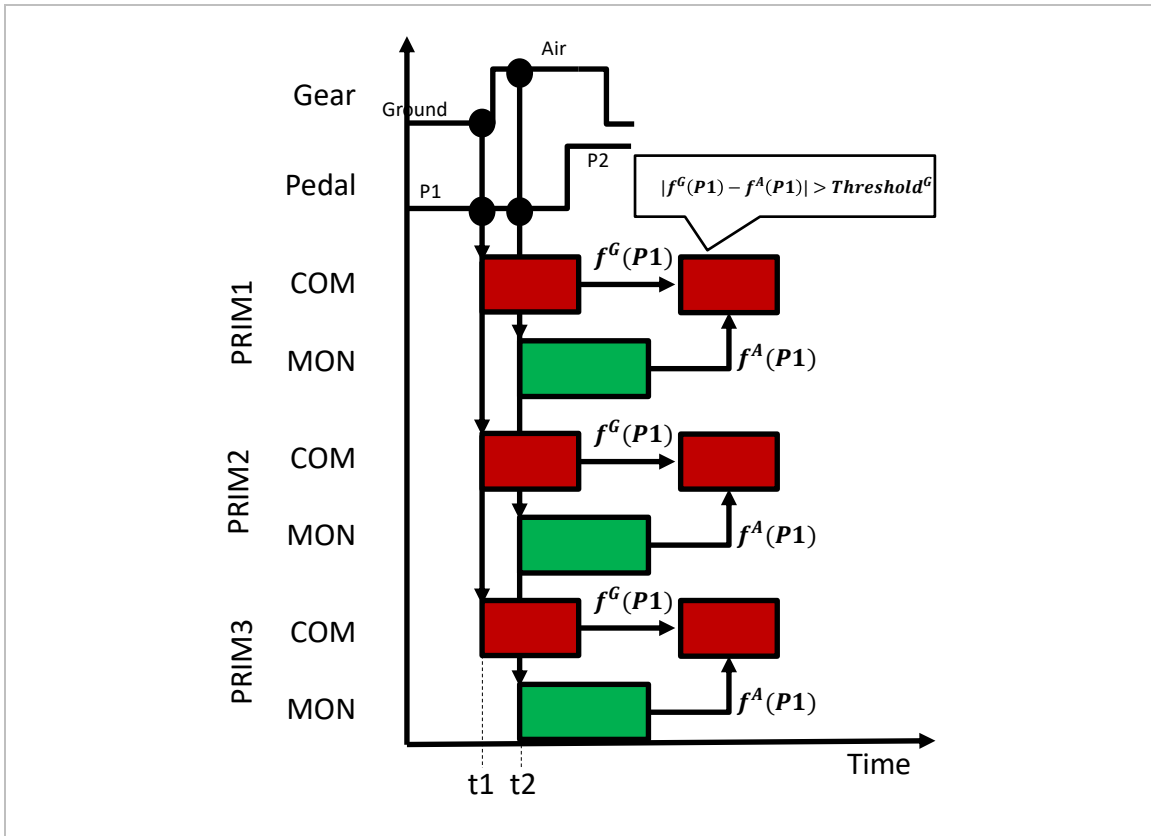

Figure 2: Channel Asynchronism Timeline

Figure 2 shows one specific time sequence that, according to the report, can occur in the system and would explain the triple failure. Specifically, the figure shows all COM processors (from the three PRIM computers) reading the landing gear (and pedal) position at the same time at time  $t_1$ . This occurrence is then followed by the reading of the gear and pedal position by all MON processors at time  $t_2$ . Given that the plane is in ground mode at time  $t_1$ , all COM processors use the “lateral ground law” (identified as  $f^G(P1)$  in the figure) to calculate the rudder command. On the other hand, all MON processors then use the “lateral flight law” (identified as  $F^A(P1)$  in the figure) to calculate the rudder command. The MON command is then communicated back to the COM processor, and it calculates the difference and compares it to the threshold ( $|f^G(P1) - f^A(P1)| > Threshold^G$ ).

Clearly, while MON and COM use the same pedal input ( $P1$ ) they use different functions to calculate the output, violating the implicit assumption of the comparison (i.e., they compare results of the computation from the same control law). The difference exceeded the threshold and PRIM1 fails-over to PRIM2. However, since PRIM2 and PRIM3 suffer from exactly the same flaw, they both fail as well. The end result is that all three MON processors from the three PRIM computers evaluated that they exceeded the tolerance threshold, and all three executed a failover that led to the switching to the secondary computers.

It is worth noting that Figure 2 shows only one possible sequence of events that could lead to this incident. In reality, any sequence that leads COM and MON to execute different control laws will lead to the same incident.

---

## Automatic Certification Argumentation

At the core of E0 is the need to verify if we can use automatic argumentation methods that automate the verification procedures attached to certification arguments. This section presents the techniques from our current work that we use to implement this automation and identify possible design flaws connected to the CI202 incident report.

### Symbolic Assurance Refinement Framework

To enable the automatic argumentation, we used the Symbolic Assurance Refinement (SAR) framework and tool [de Niz 2023]. This framework allowed us to integrate analyses defined for different properties, such as timing, fault tolerance, control, security, etc. into an argumentation structure that validates their assumptions and their interconnections with other analyses. More specifically, an analysis can make assumptions (e.g., tasks are scheduled with fixed-priority scheduling with rate-monotonic priorities) that must be true for the result of an analysis (e.g., rate-monotonic schedulability bound) guarantee (all threads always meet their deadlines) to be valid. Checking these assumptions can involve more complex analysis that would also need to have its assumptions checked for the analysis' guarantee to hold. This argumentation is depicted in Figure 3.

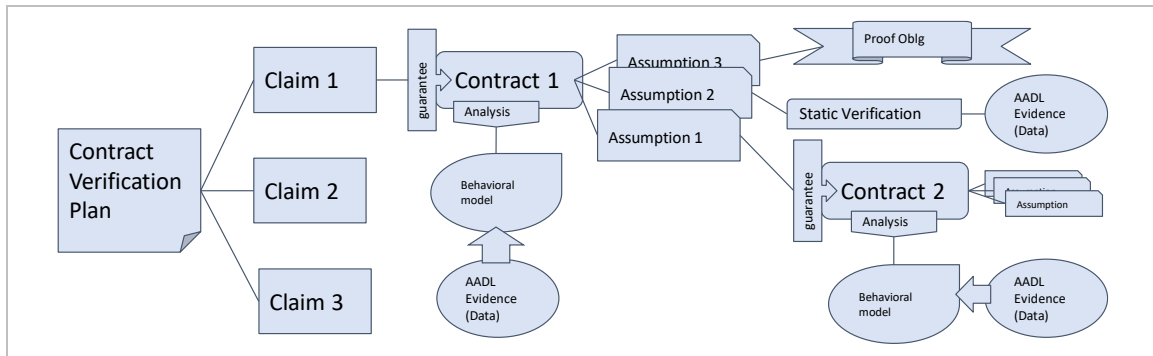

Figure 3: Contract Argumentation

SAR specifies the analysis contracts in a domain-specific language hosted as a language annex in the AADL tool (OSATE<sup>2</sup>). This template is presented in Listing 1.

```

annex contract {**
  contract <name> {
    queries
      <model var> = <query to obtain model data>
    domains
      <domain reference>
    input assumptions
      <Bool func to check data consistency>(<model vars>)
    assumptions
      <Bool func>(<model vars>)
      -> <symbolic assertion>
    analysis
      <Bool func>(<model vars>)
      -> <symbolic guarantee>
  }
**};

```

Listing 1: Analysis Contract Template

Analysis contracts have three main parts: (1) a guarantee that is encoded symbolically (in SMT in the current implementation), (2) assumptions that are assertions also specified symbolically, and (3) an analysis that takes the form of a Boolean proposition that can be implemented as an imperative function that takes model data (model variables) and verifies specific conditions that would make the guarantee true. For instance, checking if a taskset is schedulable using the rate-monotonic harmonic taskset bound implies only checking if the sum of the utilization of all the tasks running in a single processor is below 100 percent (i.e., a simple test like  $\sum_{i \in \text{taskset}} \frac{WCET_i}{\text{Period}_i} \leq 1$ ). However, here the main challenge is checking all the assumptions of the analysis, specifically

1. All tasks are periodic. In the model (e.g., AADL model) this can be a flag but would need to be checked in the implementation.
2. Periods of the tasks are harmonic (i.e., are multiples of each other).  $\forall i, j \in \text{taskset} : (\text{Period}_i > \text{Period}_j) \rightarrow \text{Period}_i \bmod \text{Period}_j = 0$
3. Priorities are rate monotonic.  $\forall i, j \in \text{taskset} : (\text{Period}_i < \text{Period}_j) \rightarrow \text{Priority}_i > \text{Priority}_j$  (A larger priority number implies a higher priority.)
4. Periods are equal to their deadlines.
5. Tasks are scheduled with a fixed-priority scheduler.
6. Tasks do not use mutually exclusive resources. This can be a more complex search in the model for shared resources and the protocols used to access them. This can be an independent contract whose implementation can have further assumptions.

<sup>2</sup> OSATE stands for *Open source AADL Tool Environment*.

Contracts have three additional sections that complement the main ones:

- queries (similar to SQL queries) that collect data from the architectural model for use by the analysis (Queries are, in fact, expressed in a domain-specific model query language [MQL].)
- domains that are basically the names of a separate contract module that defines symbolic variables to be used in the assumptions and guarantee statements (Some of these variables can mirror model variables, but others will be used to encode a property even if they never appear in the model. For instance, the rate-monotonic harmonic bound test guarantees that the worst-case response time of no task will exceed its deadline under any circumstance. For this, we define a worst-case response time even if it is not in the model and is never calculated in the scheduling test but is in the proofs of the paper that demonstrated the correctness of this analysis.)
- input assumptions that validate the data obtained in the queries to check if there is enough data to run the analysis (These are different from the other assumptions [we call analysis assumptions] in that if we do not have enough data [i.e., input], then we cannot run the analysis function. However, if the analysis assumptions are not met, then the result would be invalid even if we have enough data.)

## Proof Obligations and Refinement

SAR enables two forms of analysis assumption verification. First, SAR verifies the existence of model data that will make the assumption false. For instance, if the model already has priorities and periods assigned to tasks, then we can check if the assumption can be violated with this data. If we do not have data that contradicts the assumption, then we can assume that it is correct. This assumption is implemented by the SMT engine that determines if there are symbolic variable values that can satisfy all our assumptions. This determination is useful for the verification of partial models when we do not have everything specified yet. However, assumptions verified this way are considered **proof obligations**, which are basically deferred obligations to verify assumptions.

Second, SAR verifies that the data we have or do not have would not enable an assignment that would contradict the assumption. For instance, if the model has no information about priorities, we will verify if we can find values for the symbolic variable that would make some assumption false. This verification assumes that we now must have all the information to validate all the claims and assumptions. Hence, if this verification fails, it means that we still have proof obligations to fulfill, and we need to refine the model to verify the pending assumptions/claims. This type of verification is formally known as ensuring that a formula is valid (for all assignments).

The first type of verification allows us to verify partial models. This, in turn, allows us to keep refining the model and verifying each refinement step. Finally, once we believe we have a complete model, we can then use the second type of verification to validate whether we are truly done.

## Assurance Argumentation

The contract argumentation starts at the top from a verification plan to capture verification claims and the analysis contracts that can discharge them. These contracts follow the argumentation structure presented in Figure 3. The verification plan structure is presented in Listing 2 along with an example contract for end-to-end timing analysis.

```
annex contract {**
  verification plan verifyEndToEndTiming {
    component
      s: EndToEndTimingExample::mysystem.i;
    domains
      schedulability;
    claims
      `And([E2EResponses[i] <= E2ELatencies[i]
            for i in range(len(E2EResponses))` ;
    contracts
      EndToEndDelayedCommunicationContract;
  }

  contract EndToEndDelayedCommunicationContract {
    domains
      schedulability;
    queries
    input assumptions
      '''areEndToEndLatenciesInputDataComplete(
        ${periods$}, ${wcets$}, ${deadlines$}, ${names$})''';
    assumptions
      contract areConnectionsDelayedContract;
      argument schedulabilityArgument;
    guarantee
      <=> `And([E2EResponses[i] <= E2ELatencies[i]
                for i in range(len(E2EResponses))])`;
    analysis
      '''meetEndToEndLatencies(${synchronization::flowComponents$},
        error0)''';
  }

  argument schedulabilityArgument {
    domains
      schedulability;
    guarantee
      <=> `And([Deadlines[i] >= Responses[i]
                for i in range(len(Deadlines))])`;
    argument
      or(
        contract RMAHarmonicBoundContract
        contract RMANonHarmonicBoundContract
        contract fpResponseTimeContract
      );
  }
**};
```

Listing 2: Verification Plan

Listing 2 shows the `verifyEndToEndTiming` verification plan that includes the contracts (only the `EndToEndDelayedCommunicationContract` in this case) that are used to verify all aspect of the claims presented in the verification plan. (This is an SMT encoding of the claims.)

In the description of the `EndToEndDelayedCommunicationContract` in Listing 2, we see that its assumptions are verified with another contract (`areConnectionsDelayedContract`) and an argument (`schedulabilityArgument`). The `schedulabilityArgument` argument enables the selection of different forms of verification of assumptions (different scheduling analysis) that enables the selection of different forms of verification of this assumption (different scheduling analysis).

The details of the `schedulabilityArgument` are also presented in the listing and show how it is possible to combine multiple contracts into a Boolean formula, or, in this case, to use any of the contracts that are possible to use. In this particular case, it will use the `RMAHarmonicBoundContract` if it can verify its assumptions, which includes both that the priority assignment is rate monotonic and that the periods of the task are harmonic to each other. If it cannot verify the period harmonicity, the **OR** encoding then allows us to try to use the `RMANonHarmonicBoundContract` contract that does not require period harmonicity. Finally, if neither of the two assumptions are met, it is then possible to use the `fpResponseTimeContract` contract that does not require either of the two but requires other assumptions (e.g., the deadline is shorter or equal to the period).

---

## Assurance Argumentation for the A330

While we lack the specific claims of the original certification of the A330 aircraft and the role of the replication patterns (with the PRIM computers and their COM/MON processors), we first explore a generic form of the replication to identify potential claims, verification procedures, and assumptions to develop an assurance argumentation.

### Replication Patterns

The A330 architecture has two forms of replication that, to our understanding, address different properties. In particular, one type of replication addresses reducing the possibility of calculating the wrong value or preserving the value *integrity* (or just *Integrity* for short). The other goes after preserving the availability of the computation even if faults occur; this is known as *Availability*.

#### Integrity Replication

From the incident report, we believe the A330 is implementing integrity replication with the combination of the COMMAND module (COM) and the MONITOR module (MON) that calculate the same output from the input commands, and the COM uses the MON data to check its own computation.

## Assumptions

The integrity replication has at least two assumptions:

1. Development diversity requires that two different teams develop two (or more) modules independently. The rationale behind this approach is that if we develop two different implementations that can fail differently, we would be able to detect the failure of the pair based on the difference in the output values. This diversity assumption can be checked with the proper execution of a development process that enforces it, but the incident report does not point to a failure related to this assumption.
2. Module pair should use the same input, which means that both COM and MON should receive the same input to create the proper comparison between the two. More importantly, in the specific case covered by this paper, while it is possible to get some small variation in the input from the pedal sensor, a difference in the air/ground mode is catastrophic given that it selects different control laws for the same module. This behavior is exactly what the incident report describes as a key violation.

## Availability Replication

Availability replication is used to tolerate hardware failures and preserve a module to continue running. Availability claims aim to satisfy measures of tolerance to failures in the form of either some informal argument on failure independence or a more formal probability of the absence of service due to the failure of all the replicas.

## Assumptions

Key to the availability replication is the assumption that the modules must fail independently. More specifically, this assumption means that the hardware where the modules run must fail independently. For this paper, we focus only on this assumption given that we believe it informs the design of the avionics system and interacts with the integrity replication scheme.

## Replication Modeling

We first formalize the availability claim (probability of absence of service) connected to a specific verification procedure: probabilistic fault-tree analysis (FTA). In this case, we create the replicated end-to-end flow architecture (that captures the channel construct) that reads from the sensors, computes the actuation in the PRIM (COM/MON) computers, and sends it to the actuator as shown in Figure 4. This figure depicts with each box an independent thread (including the sensors and actuator boxes), representing the last thread that interacts with the appropriate device (i.e., reads from the

sensor registers or writes to the actuator registers) that runs in its own processor. For simplicity, we assume that all processors fail independently.<sup>3</sup>

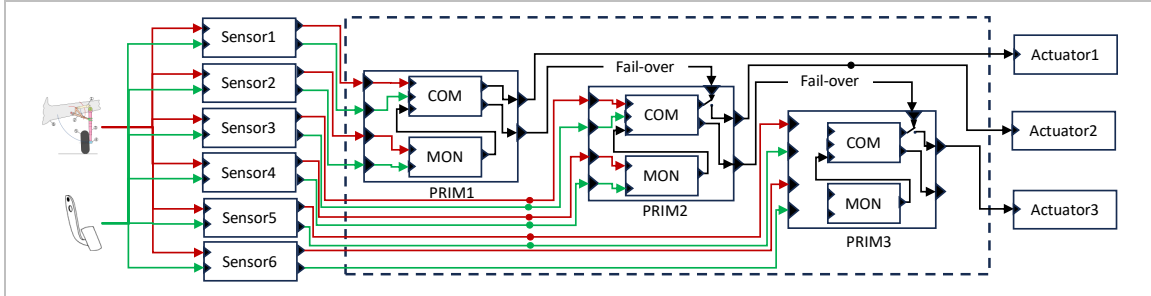

Figure 4: All Independent Channel Threads

### Fault-Tree Analysis (FTA)

FTA is a top-down approach that defines the faults of interest under which a tree of events is created that lead to such a fault [Rausand 2014]. The tree is constructed by first connecting abstract events to the top-level failure by either an **AND** or an **OR** connector to represent that for the fault to occur, either all the next level abstract events need to occur or only one of such events needs to occur respectively. The decomposition of the next level events continues in the same fashion until basic events are identified. This construct can also be translated into what is known as a *reliability block diagram*, where **OR** compositions are represented as blocks connected in series while **AND** are those connected in parallel. These patterns are shown in Figure 5.

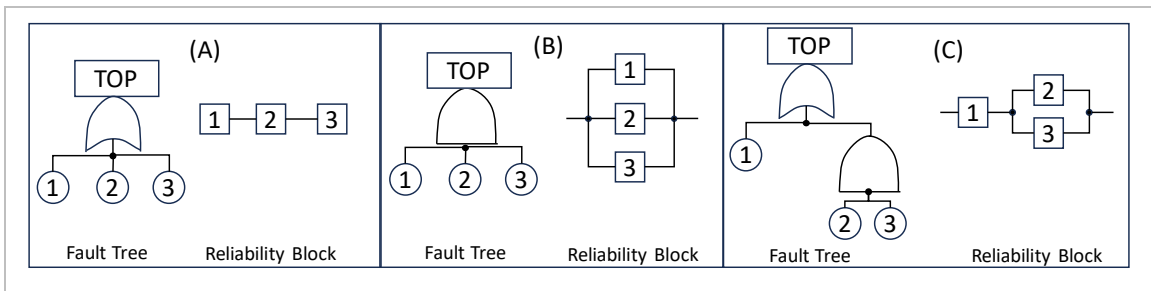

Figure 5: Fault-Tree and Reliability Block Diagrams

Fault trees allow two types of analysis: a qualitative analysis and a quantitative analysis. The qualitative analysis allows us to evaluate the set of basic events that, if they occur simultaneously, makes the top fault occur. These are known as the *cut set*. A cut set is minimal if it cannot be reduced without losing its status as a cut set.

In addition, a fault tree also allows us to identify common causes that break a failure-independence expectation. For instance, the minimal cut sets of the systems in Figure 5 are  $\{1\}, \{2\}, \{3\}$  for system **A**,  $\{1,2,3\}$  for system **B** and  $\{1\}, \{2,3\}$  for system **C**. These sets allow us, for instance, to identify

<sup>3</sup> Further verification is required for the final implementation e.g., power supplies, cooling systems, etc.

single points of failures as cut sets with a single element. In our example, both system **A** and **C** have them, but system **B** does not.

The quantitative analysis, on the other hand, allows us to calculate the probability of failure by assigning probabilities of occurrence to each basic event and deriving the probability of occurrence of the top event from them. This probability is calculated with

$$Q_o(t) = 1 - \prod_{1 \leq j \leq k} (1 - \check{Q}_j(t))$$

Equation 1

with  $\check{Q}_j(t)$  as the failure probability of cut set  $C_j$  calculated as

$$\check{Q}_j = \prod_{i \in C_j} q_i(t)$$

Equation 2

where  $q_i(t)$  can be calculated as a single event occurring at time  $t$  (after some time of service) that is not repairable or is repairable and needs to be calculated over time. For the objective of this analysis, we assume that it is not repairable and that  $q_i(t)$  is given; we apply it in the A330 architecture to evaluate potential claims and their assumptions.

### AADL Model

To capture the replication characteristics to perform the FTA, we created an AADL ) model [SAE 2009] following the architecture in Figure 4<sup>4</sup> where each component is a thread. We next created a hardware architecture where each thread has its own processor assigned to it. We then identify the internal control/data flows (identified as  $f<number>$ ) that cross each component from input to output ports, the connections from output to input ports (identified as  $c<number>$ ), and the flow source (identified as  $s<number>$ ) and flow sinks (identified as  $k<number>$ ). This architecture is shown in Figure 6.

---

<sup>4</sup> Not shown for brevity.

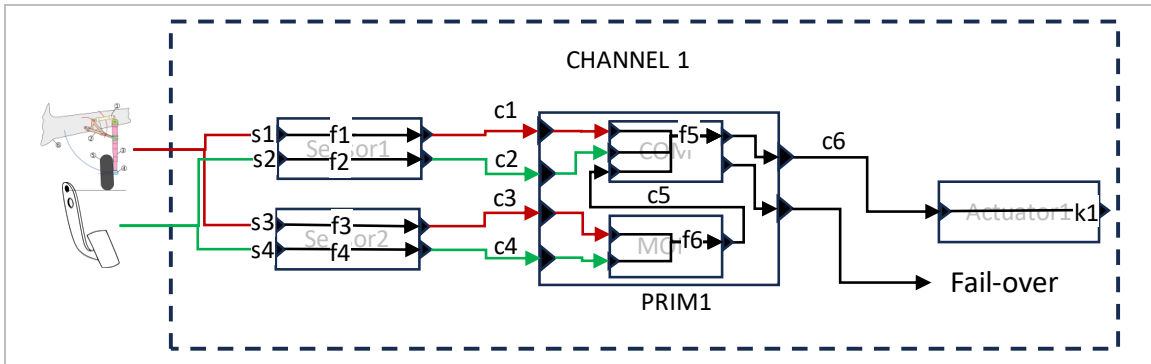

Figure 6: Channel Composition

We now discuss two more details added to the AADL model that we could not include in the figure:

1. All ports in this model are *Data* ports, which means that when the thread activates, it reads whatever is in the port buffer and continues its execution.
2. All connections are *Delayed* connections, which means that whatever the thread in the output port of the connection sends, it arrives at the next periodic activation of the receiving thread.

This combination allows us to (1) abstract away the network communication delays and assume that the communication will happen within the execution of the previous periodic activation and (2) assume that when the receiving thread activates, it already has the most recent data in its input ports.<sup>5</sup> Given all this information, we can define two end-to-end flows, as presented in Listing 3.

```
pedalToActuationCOMPRIM1: end to end flow Sensor1.s1->
Sensor1.f1->c2->COM.f5->c6->Actuator1.k1;

pedalToActuationMONPRIM1: end to end flow Sensor2.s3->
Sensor2.f3->c4->MON.f6->c5->COM.f5->c6->Actuator1.k1;
```

Listing 3: End-to-End Flows Replica 1

Listing 3 only lists one flow in each component because all the flows are equivalent given that their data is available at the time of the thread activation. Moreover, the end-to-end flow `pedalToActuationMONPRIM1` captures the dependency between `COM` and `MON` that is not present in the end-to-end flow `pedalToActuationCOMPRIM1`. These characteristics of Listing 3 allow us to focus only on the `MON` end-to-end flows when describing the replication pattern.

<sup>5</sup> Clearly, both assumptions need and can be verified with a more detailed model, but this discussion is not included in this paper.

To describe the replication pattern, we define that the main flows within each of the PRIM computers must be replicas of each other. In Listing 4, we capture only the `pedalToActuationMONPRIMx` given that it captures the internal dependencies between the MON and COM processors.

```
ReplicationProperties::Replicating =>(reference
(pedalToActuationMONPRIM2), reference
(pedalToActuationMONPRIM3)) applies to pedalToActuatorMONPRIM1;
```

*Listing 4: Replication Specification*

In addition, we specify the probability of failure of each processor and the target reliability (or availability) of the replicated flow as presented in Listing 5. (Note that this probability is notional and does not represent the typical requirement of a commercial aircraft.)

```
ReplicationProperties::ReliabilityTarget => 0.85 applies to
pedalToActuationMONPRIM1;

ReplicationProperties::FailureProbability => 0.01 applies to
Sensor1.processor;
```

*Listing 5: Reliability Specs*

We developed a probabilistic FTA analysis that uses Equation 1 and Equation 2. In this analysis, we transform the graph created with the end-to-end flows into a reliability block diagram based on the processor each thread runs in and their dependencies. Two observations are in order. First, COM depends on MON given that it uses its output to evaluate output value differences; therefore, there is no advantage to running them in separate processors since if one stops working (e.g., is not available), the other will not be able to verify its output and will fail as well. Second, for the COM comparison with MON, it needs to read the pedal and landing gear at exactly the same time since it is not possible to know exactly when the mode switch will happen. This new requirement is captured in Listing 6, which shows only the PRIM1 part.

```
ReplicationProperties::IntegrityReplicas =>(reference
pedalToActuationCOMPRIM1) applies to pedalToActuationMONPRIM1;

ReplicationProperties::ReplicasStartJitterTolerance => 0 ms
applies to pedalToActuationCOMPRIM1;

Period 100 ms applies to Sensor1.thread;

Period 100 ms applies to Sensor2.thread;
```

*Listing 6: Simultaneous Activation*



```

Period 100 ms applies to Sensor1.thread;
Deadline 100 ms applies to Sensor1.thread;
Priority 1 applies to Sensor1.thread;
Compute_Execution_Time 10 ms applies to Sensor1.thread;
Actual_Processor_Binding =>(reference (repl.com.proc))
    applies to Sensor1.thread;
Preemptive_Scheduler => True applies to repl.com.proc;

```

Listing 7: Scheduling Properties

## Automatic Certification Argumentation

Using the SAR framework described in the Symbolic Assurance Refinement Framework section on page 7, we developed the verification plan for the CI202 incident presented in Listing 8. This listing starts with the verification plan specification module at the top and presents three contracts used in the plan to verify the claims and assumptions for integrity (SamplingSynchronizationContract), availability (ReliabilityContract), and end-to-end timing (EndToEndDelayedCommunicationContract). In the claims section of the verification plan, we also have three SMT claims about the three claims that we verify.

```

annex contract {**
  verification plan verifySynchronization {
    component
      s: EndToEndTimingExample::mysystem.i;
    domains
      synchronization;
      reliability;
    claims
      `And([E2ESamplingJitter[i] <= E2ESamplingJitterTolerance[i]
        for i in range(len(E2ESamplingJitter))])`;
      `And([Reliability[i]>=ReliabilityTarget[i]
        for i in range(len(Reliability))])`;
      `And([E2EResponses[i] <= E2ELatencies[i]
        for i in range(len(E2EResponses))])`;
    contracts
      SamplingSynchronizationContract;
      EndToEndDelayedCommunicationContract;
      ReliabilityContract;
  }

  contract SamplingSynchronizationContract {
    domains
      synchronization;
    guarantee
      <=> `And([E2ESamplingJitter[i] <= E2ESamplingJitterTolerance[i]
        for i in range(len(E2ESamplingJitter))])`;
    analysis
      '''areFlowsInSync1(${synchronization::flowComponents$},error0)''';
  }

  contract ReliabilityContract {
    domains
      reliability ;
    assumptions

```

```

        '''areReplicasOnIndependentProcessors(
            ${synchronization::flowComponents$},error0)''';
    guarantee
        ⇔ `And([Reliability[i] >= ReliabilityTarget[i]
            for i in range(len(Reliability))` ;
    analysis
        '''isE2EFlowProbabilityOfFailureMet (${replicatede2es$},error0)` ;
}

contract EndToEndDelayedCommunicationContract {
    domains
        schedulability;
    queries
    input assumptions
        '''areEndToEndLatenciesInputDataComplete(
            ${periods$}, ${wcets$}, ${deadlines$}, ${names$})''';
    assumptions
        contract areConnectionsDelayedContract;
        '''areAllThreadsPeriodic(
            ${threads$}, ${protocols$}, ${names$},error0)'''
            => `And([Periodics[i] for i in range(len(Periodics))])`;
        '''areAllDeadlinesConstrained(
            ${threads$},${periods$},
            ${deadlines$}, ${names$},error0)'''
            => `And([Deadlines[i] <= Periods[i]
                for i in range(len(Deadlines))])`;
        argument schedulabilityArgument;
    guarantee
        <=> `And([E2EResponses[i] <= E2ELatencies[i]
            for i in range(len(E2EResponses))])`;
    analysis
        '''meetEndToEndLatencies (${synchronization::flowComponents$},
            error0)''';
}

argument schedulabilityArgument {
    domains
        schedulability;
    guarantee
        <=> `And([Deadlines[i] >= Responses[i]
            for i in range(len(Deadlines))])`;
    argument
        or(
            contract RMAHarmonicBoundContract
            contract RMANonHarmonicBoundContract
            contract fpResponseTimeContract
        );
}
**);

```

*Listing 8: Verification Plan*

The details of the `SamplingSynchronizationContract` contract are also included in Listing 8. The guarantee is expressed in SMT and is checked with the Python function `areFlowsInSync1()` in the analysis section to verify the `ReplicaStartJitterTolerance` presented in Listing 6.

Similar to the `SamplingSynchronizationContract`, the `ReliabilityContract` presented in Listing 8 includes the verification of the independence assumption that is verified with the Python function `areReplicasOnIndependentProcessors()`. This function returns `True` if it is able to evaluate that the functions in the end-to-end flows that model the different PRIM computers run on independent processors and `False` otherwise. (This end-to-end flows data is obtained

from queries in MQL that obtain the data from the AADL model; they are not shown for brevity.) Then, in section analysis, an invocation to the Python function `isE2EFlowProbabilityOfFailureMet` verifies whether or not the reliability requirement presented in Listing 5 is met.

The last contract presented in Listing 8 is the `EndToEndDelayedCommunicationContract`. The details presented in the listing follow a similar pattern to the other two contracts with the following exceptions. First, it adds an input assumptions section with a Python call to evaluate whether we have enough data to run this contract. Second, it adds the contract `areConnectionsDelayedContract` as one of the assumptions to verify, which is one of the complex assumptions that uses another contract to verify it. Finally, it adds the argument `schedulabilityArgument` that enables the selection of different forms of verification of this assumption (different scheduling analysis), as discussed in the Assurance Argumentation section on page 10.

---

## Concluding Remarks

The objective of E0 was to validate if the automation of certification arguments can indeed identify problems that occur in real systems. Key to this validation exercise was the following:

1. The connection of the arguments to certifiers and designer rationale is typical of certification reasoning.
2. The arguments can be expressed at a high enough level of abstraction to enable humans to evaluate whether the arguments are properly captured or not.
3. The verification of the arguments and the verification procedures of the claims in such arguments can be automatically processed by a computer.
4. The lower level assumptions of the verification procedures (i.e., analysis) can be captured and verified at lower levels of detail, incrementally increasing the details getting all the way down to implementation but in a way that each level can be reasoned incrementally.

E0 allowed us to validate all these aspects. However, limits to the incremental validation did not enable us to produce a full implementation given the lack of information in our example. At the same time, we understand that more work is required to validate if this approach can be extended to the scale of full certification claims and incremental recertification. Subsequent experiments will explore this issue in more detail.

We learned the following lessons from conducting the research presented in this paper:

- From a methodological point of view, E0 allowed us to demonstrate how multiple abstractions used by different verification domains (real-time scheduling, availability, and integrity) can be assembled and cross validated in an automatic, formal way. Importantly, these abstractions are connected to architectural models that are reasonably easy to understand by engineers and

certifiers. These abstractions can also be connected to the results from the specific analysis (even if all of the details are not fully understood).

- E0 allowed us to exercise the reuse of arguments (e.g., for end-to-end timing verification) that encapsulated multiple checks at lower levels of abstractions to which the modeler reusing the argument was not exposed. At the same time, new analyses were added (availability and integrity) along with their assumptions and assumption checking analyses; this allowed us to automatically identify failures to meet these assumptions in the fictitious design variations that we explored.

In summary, this modeling and automatic verification experiment showed a robust process that allowed us to encode lessons learned in an executable format. This encoding can then be reused as we develop new arguments and verification procedures that can be used in new system developments. More importantly, the encoding enables the automatic integration of development activities to the production of certification evidence.

---

## References/Bibliography

*URLs are valid as of the publication date of this report.*

### **[ASERTW 2022]**

de Niz, Dionisio; Andersson, Bjorn; Klein, Mark; Kim, Hyoseung; Lehoczky, John; Schmidt, Doug; & Romanski, George. *Assurance Evidence of Continuous Evolving Real-Time Systems*. Assurance Evidence of Continuously-Evolving Real-Time Systems (ASERT) Workgroup. 2022. <https://www.asertw.org/>

### **[Benveniste 2018]**

Benveniste, Albert; Caillaud, Benoît; Nickovic, Dejan; Passerone, Roberto; Raclet, Jean-Baptiste; Reinkemeier, Philipp; Sangiovanni-Vincentelli, Alberto; Damm, Werner; Henzinger, Thomas A.; & Larsen, Kim G. Contracts for System Design. *Foundations and Trends in Electronic Design Automation*. Volume 12. Issue 2-3. 2018. <https://www.nowpublishers.com/article/Details/EDA-053>

### **[Brau 2018]**

Brau, G.; Hugues, J.; & Navet, N. Towards the Systematic Analysis of Non-Functional Properties in Model-Based Engineering for Real-Time Embedded Systems. *Science of Computer Programming*. Volume 156. Issue 1. 2018. <http://dx.doi.org/10.1016/j.scico.2017.12.007>

### **[Cofer 2012]**

Cofer, Darren; Gacek, Andrew; Miller, Steven P.; Whalen, Michael W.; LaValley, Brian; & Sha, Lui. Compositional Verification of Architectural Models. In *NASA Formal Methods*. Pages 126–140. 2012.

**[de Niz 2023]**

de Niz, Dionisio & Wrage, Lutz. Symbolic Refinement for CPS. *ACM SIGAda Ada Letters*. Volume 43. Issue 1. Pages 88–93. 2023. <https://doi.org/10.1145/3631483.3631498>

**[ERSA 2022]**

1<sup>st</sup> International Workshop on Explainability of Real-Time Systems and their Analysis (ERSA). IEEE Real-Time Systems Symposium (RTSS 2022). Houston, Texas. December 2022. <https://sites.google.com/view/ersa22>

**[ERSA 2023]**

2<sup>nd</sup> International Workshop on Explainability of Real-Time Systems and their Analysis (ERSA). IEEE Real-Time Systems Symposium (RTSS 2023). Taipei, Taiwan. December 2023. <https://sites.google.com/view/ersa23>

**[Hoare 1969]**

Hoare, C. A. R. An Axiomatic Basis for Computer Programming. *Communications of the ACM*. Volume 12. Number 10. Pages 576–580. October 1969. <https://dl.acm.org/doi/10.1145/363235.363259>

**[Holzmann 1997]**

Holzmann, Gerard J. The Model Checker SPIN. *IEEE Transactions on Software Engineering*. Volume 23. Number 5. Pages 279–295. 1997. <https://doi.org/10.1109/32.588521>

**[Jackson 2019]**

Jackson, Daniel. Alloy: A Language and Tool for Exploring Software Designs. *Communications of the ACM*. Volume 62. Issue 9. Pages 66–76. August 2019. <https://doi.org/10.1145/3338843>

**[Kesten 1998]**

Kesten, Yonit; Pnueli, Amir; & Raviv, Li-on. Algorithmic Verification of Linear Temporal Logic Specifications. In *Automata, Languages and Programming*. Larsen, K. G.; Skyum, S.; & Winskel, G. [editors]. Springer Berlin Heidelberg. 1998.

**[Nam 2011]**

Nam, Min-Young; de Niz, Dionisio; Wrage, Lutz; & Sha, Lui. Resource Allocation Contracts for Open Analytic Runtime Models. In *2011 Proceedings of the Ninth ACM International Conference on Embedded Software (EMSOFT)*. Pages 13–22. October 2011. <https://doi.org/10.1145/2038642.2038647>

**[Rausand 2014]**

Rausand, Marvin. *Reliability of Safety-Critical Systems: Theory and Applications*. John Wiley & Sons, Inc. 2014. <https://onlinelibrary.wiley.com/doi/book/10.1002/9781118776353>

### **[Ruchkin 2014]**

Ruchkin, Ivan; de Niz, Dionisio; Garlan, David, & Chaki, Sagar. Contract-Based Integration of Cyber-Physical Analyses. In *EMSOFT '14: Proceedings of the 14<sup>th</sup> International Conference on Embedded Software*. Pages 1-10. October 2014. <https://doi.org/10.1145/2656045.2656052>

### **[SAE 2009]**

Architecture Analysis and Design Language (AADL). SAE International. Standard AS5506. March 2009. <https://www.sae.org/standards/content/as5506/>

### **[Shankar 2022]**

Shankar, Natarajan; Bhatt, Devesh; Ernst, Michael; Kim, Minyoung; Varadarajan, Srivatsan; Millstein, Suzanne; Navas, Jorge; Biatek, Jason; Sanchez, Huascar; Murugesan, Anitha; Ren, Hao. *DesCert: Design for Certification*. March 2022. <https://arxiv.org/abs/2203.15178>

### **[TTSB 2021]**

Taiwan Transportation Safety Board (TTSB). *China Airlines Flight CI202 Occurrence*. TTSB-AOR-21-09-001. September 2021. [https://www.ttsb.gov.tw/media/4936/ci-202-final-report\\_english.pdf](https://www.ttsb.gov.tw/media/4936/ci-202-final-report_english.pdf)

### **[Wang 2022]**

Wang, Timothy E.; Daw, Zamira; Nuzzo, Pierluigi; & Pinto, Alessandro. Hierarchical Contract-Based Synthesis for Assurance Cases. In *NASA Formal Methods: 14th International Symposium, NFM 2022*. May 2022. [http://dx.doi.org/10.1007/978-3-031-06773-0\\_9](http://dx.doi.org/10.1007/978-3-031-06773-0_9)

---

## **Legal Markings**

Copyright 2024 Carnegie Mellon University and the authors (or their employers).

This material is based upon work funded and supported by the Department of Defense under Contract No. FA8702-15-D-0002 with Carnegie Mellon University for the operation of the Software Engineering Institute, a federally funded research and development center.

The view, opinions, and/or findings contained in this material are those of the author(s) and should not be construed as an official Government position, policy, or decision, unless designated by other documentation.

References herein to any specific commercial product, process, or service by trade name, trade mark, manufacturer, or otherwise, does not necessarily constitute or imply its endorsement, recommendation, or favoring by Carnegie Mellon University or its Software Engineering Institute.

References to any specific incident(s) in this paper does not suggest, insinuate, imply, assert, claim, or allege any wrongdoing, fault, negligence, liability or otherwise on behalf of any individual, entity and/or government.

NO WARRANTY. THIS CARNEGIE MELLON UNIVERSITY AND SOFTWARE ENGINEERING INSTITUTE MATERIAL IS FURNISHED ON AN "AS-IS" BASIS. CARNEGIE MELLON UNIVERSITY MAKES NO WARRANTIES OF ANY KIND, EITHER EXPRESSED OR IMPLIED, AS TO ANY MATTER INCLUDING, BUT NOT LIMITED TO, WARRANTY OF FITNESS FOR PURPOSE OR MERCHANTABILITY, EXCLUSIVITY, OR RESULTS OBTAINED FROM USE OF THE MATERIAL. CARNEGIE MELLON UNIVERSITY DOES NOT MAKE ANY WARRANTY OF ANY KIND WITH RESPECT TO FREEDOM FROM PATENT, TRADEMARK, OR COPYRIGHT INFRINGEMENT.

[DISTRIBUTION STATEMENT A] This material has been approved for public release and unlimited distribution. Please see Copyright notice for non-US Government use and distribution.

This work is licensed under a Creative Commons Attribution-NonCommercial 4.0 International License. Requests for permission for non-licensed uses should be directed to the Software Engineering Institute at [permission@sei.cmu.edu](mailto:permission@sei.cmu.edu).

Carnegie Mellon® is registered in the U.S. Patent and Trademark Office by Carnegie Mellon University.

DM24-0010

---

## Contact Us

Software Engineering Institute  
4500 Fifth Avenue, Pittsburgh, PA 15213-2612

**Phone:** 412/268.5800 | 888.201.4479

**Web:** [www.sei.cmu.edu](http://www.sei.cmu.edu)

**Email:** [info@sei.cmu.edu](mailto:info@sei.cmu.edu)