

# Testing of New Fluorine-Free Green Surfactant Mixtures to Replace AFFF - Demonstration Plan

**WP21-3568**

**Sumaer Kamboj Ph.D.  
ADA Technologies**

**Final Report**

**DATE: October 27<sup>th</sup> 2023**



# REPORT DOCUMENTATION PAGE

*Form Approved*  
OMB No. 0704-0188

The public reporting burden for this collection of information is estimated to average 1 hour per response, including the time for reviewing instructions, searching existing data sources, gathering and maintaining the data needed, and completing and reviewing the collection of information. Send comments regarding this burden estimate or any other aspect of this collection of information, including suggestions for reducing the burden, to Department of Defense, Washington Headquarters Services, Directorate for Information Operations and Reports (0704-0188), 1215 Jefferson Davis Highway, Suite 1204, Arlington, VA 22202-4302. Respondents should be aware that notwithstanding any other provision of law, no person shall be subject to any penalty for failing to comply with a collection of information if it does not display a currently valid OMB control number.  
**PLEASE DO NOT RETURN YOUR FORM TO THE ABOVE ADDRESS.**

<b>1. REPORT DATE (DD-MM-YYYY)</b> 27/10/2023		<b>2. REPORT TYPE</b> SERDP Project Outbrief		<b>3. DATES COVERED (From - To)</b> 9/1/2022 - 8/31/2024	
<b>4. TITLE AND SUBTITLE</b> Testing of New Fluorine-Free Green Surfactant Mixtures to Replace AFFF - Demonstration Plan			<b>5a. CONTRACT NUMBER</b> 22-C-0094		
			<b>5b. GRANT NUMBER</b>		
			<b>5c. PROGRAM ELEMENT NUMBER</b>		
<b>6. AUTHOR(S)</b> Sumaer Kamboj Bill Gunter			<b>5d. PROJECT NUMBER</b> WP21-3568		
			<b>5e. TASK NUMBER</b>		
			<b>5f. WORK UNIT NUMBER</b>		
<b>7. PERFORMING ORGANIZATION NAME(S) AND ADDRESS(ES)</b> ADA Technologies, Inc 11149 Bradford Rd Littleton, CO 80127				<b>8. PERFORMING ORGANIZATION REPORT NUMBER</b> WP21-3568	
<b>9. SPONSORING/MONITORING AGENCY NAME(S) AND ADDRESS(ES)</b> Office of the Deputy Assistant Secretary of Defense (Energy Resilience & Optimization) 3500 Defense Pentagon, RM 5C646 Washington, DC 20301-3500				<b>10. SPONSOR/MONITOR'S ACRONYM(S)</b> SERDP	
				<b>11. SPONSOR/MONITOR'S REPORT NUMBER(S)</b> WP21-3568	
<b>12. DISTRIBUTION/AVAILABILITY STATEMENT</b> DISTRIBUTION STATEMENT A. Approved for public release: distribution unlimited.					
<b>13. SUPPLEMENTARY NOTES</b>					
<b>14. ABSTRACT</b> The technical objectives of this project are listed below: <ul style="list-style-type: none"> <li>● Evaluate ADA formulations performance to meet MILSPEC.</li> <li>● Characterize formulation's non-extinguishment qualities: <ul style="list-style-type: none"> <li>• Expansion Ratio</li> <li>• Surface Tension</li> <li>• Viscosity</li> <li>• Drainage Time</li> </ul> </li> </ul>					
<b>15. SUBJECT TERMS</b> Fluorine-Free Green Surfactant Mixtures, AFFF, aqueous film forming foam, AFFF alternatives, surfactants, PFAS, firefighting formulations					
<b>16. SECURITY CLASSIFICATION OF:</b>			<b>17. LIMITATION OF ABSTRACT</b>  UNCLASS	<b>18. NUMBER OF PAGES</b>  27	<b>19a. NAME OF RESPONSIBLE PERSON</b> Sumaer Kamboj
<b>a. REPORT</b>  UNCLASS	<b>b. ABSTRACT</b>  UNCLASS	<b>c. THIS PAGE</b>  UNCLASS			<b>19b. TELEPHONE NUMBER (Include area code)</b> 985-705-0559

# WP21 - 35868: Demo

## Performers:

PI: Sumaer Kamboj Ph.D.

Co-PI: William Gunter

Research Technician: Mark Gaugenmaier

## Technology Focus

Development of PFAS-free firefighting foam (PFFF) to replace toxic and bio-persistent PFAS containing Aqueous Film Forming Foam. (AFFF) for use on DoD bases and by the FAA

## Research Objectives

Evaluate the effectiveness of fluorine-free firefighting (F3) foam formulations produced by ADA Technologies to develop a product that meets the updated MIL-SPEC standards for Class B firefighting foam.

## Technology Transition

- Validate ADA formulations in extreme conditions.
- Deployment in larger scale equipment

## Results (Top performing formulation)

- Extinguishment Time: 13.8 sec @ 0.32 GPM/sqft
- 25% Burnback Time : 112 sec
- Expansion Ratio : 4.43
- Surface Tension : 22.5 dyne/cm
- Viscosity : 334 cp



# Key Points

- Lower surface tension has diminishing returns on reducing extinguishment, but is directly proportional to improved burnback resistance.
- Film formation may still be possible even with negative spreading coefficient.
- Delivery method is essential in determining extinguishment.

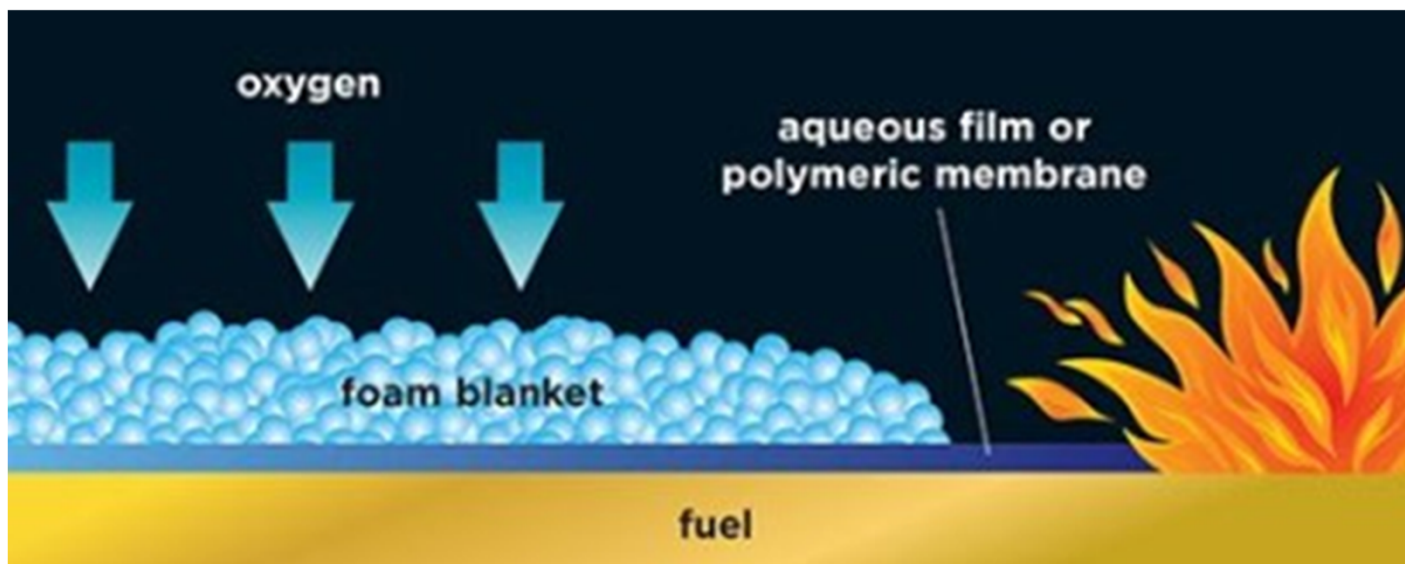

# Project Team

**PI:** Sumaer Kamboj, Formulations Chemist at ADA Technologies

PhD: Quantitative Biosciences and Engineering, Colorado School of Mines, August 2021

B.S. Major - Chemical and Bio-Chemical Engineering, Colorado School of Mines, August 2019

**Co-PI:** William Gunter, Technology Transition Manager at ADA Technologies

**Co-Performer:** John Farley, Researcher at Naval Research Lab



# Technical Objective

- Evaluate ADA formulations performance to meet MIL-SPEC.



DoD Inventory of Foam Concentrate	In Service	2,500,000 gallons
	Reserve Stock	500,000 gallons

- Characterize formulation's non-extinguishment qualities:
  - Expansion Ratio
  - Surface Tension
  - Viscosity
  - Drainage Time

# Technical Approach

Requirement	Values		Applicable publication	Test paragraph
	Type 3	Type 6		
Refractive index, minimum	1.3630	1.3580	–	4.7.1
Viscosity, centistokes			ASTM D445-74	4.7.2
Maximum at 5 °C	20	10		
Minimum at 25 °C	2	2		
Hydrogen ion concentration (pH)	7.0 to 8.5	7.0 to 8.5	–	4.7.3
Spreading coefficient, minimum	3	3	–	4.7.4
Foamability:				
Foam expansion, minimum	5.0	5.0	NFPA STD 412	4.7.5
Foam 25% drainage time, minutes, minimum	2.5	2.5	NFPA STD 412	4.7.5
Corrosion rate:				
General				
Cold rolled, low carbon steel (UNS G10100), milli in/yr, maximum	1.5	1.5	ASTM E527	4.7.7
Copper-nickel (90-10) (UNS C70600), milli in/yr, maximum	1.0	1.0	ASTM E527	4.7.7
Nickel-copper (70-30) (UNS N04400), milli in/yr, maximum	1.0	1.0	ASTM E527	4.7.7
Bronze (UNS C90500), milligrams, maximum	100	100	ASTM E527	4.7.7
Localized, corrosion-resistant (CRES) steel, (UNS S30400)	No pits	No pits	–	4.7.7
Total halides, p/m, maximum	500	250	ASTM D1821	4.7.8
Dry chemical compatibility, burn-back, resistance time, seconds, minimum	360	360	–	4.7.9
Environmental impact:				
Toxicity, LC <sub>50</sub> , mg/L, minimum	500	1000	–	4.7.12.1
COD, mg/L, maximum	1000K	500K	–	4.7.12.2
BOD <sub>20</sub> , minimum	.65	.65	–	4.7.12.3
COD				

# Surface Tension



# Expansion and Drainage

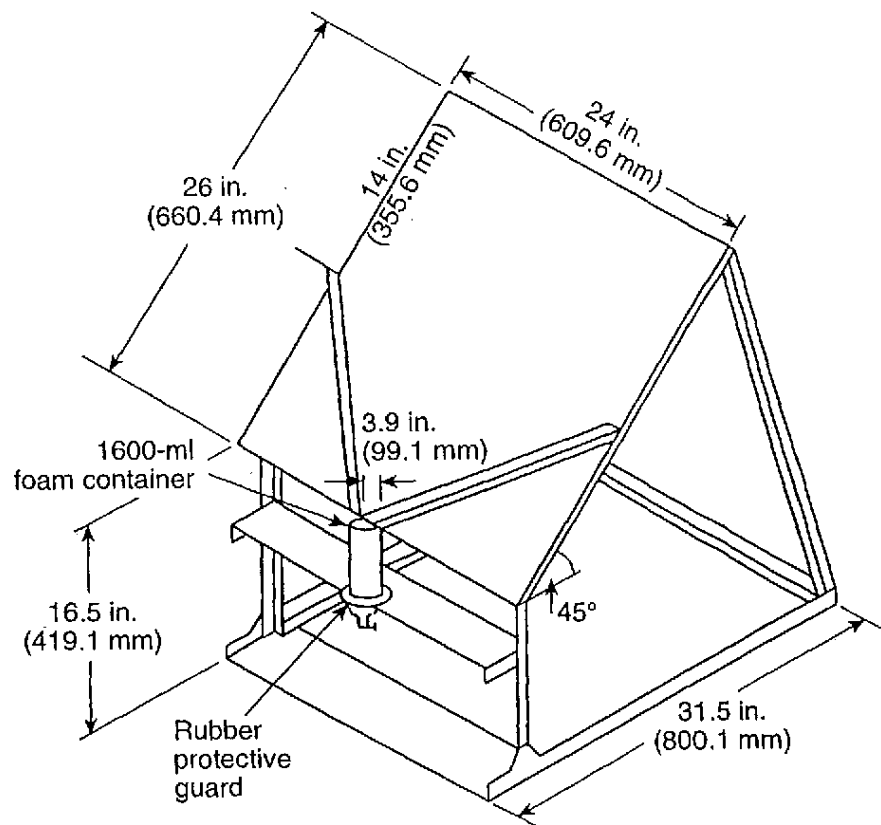

# Delivery System (1 ft<sup>2</sup> pan)

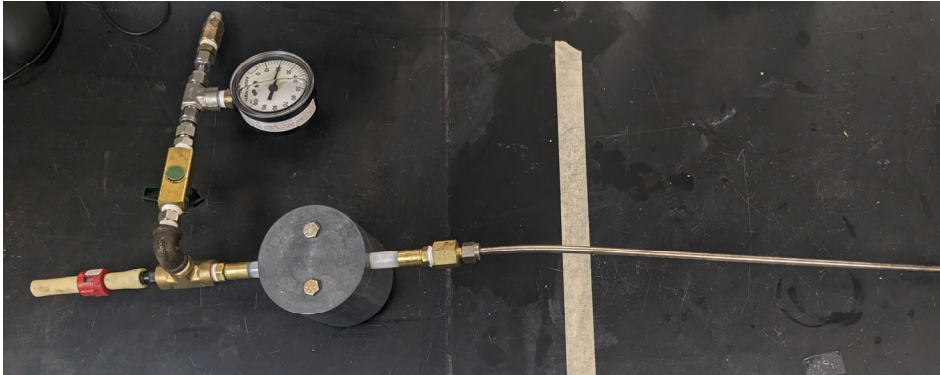

# Delivery System (5 ft<sup>2</sup> pan)

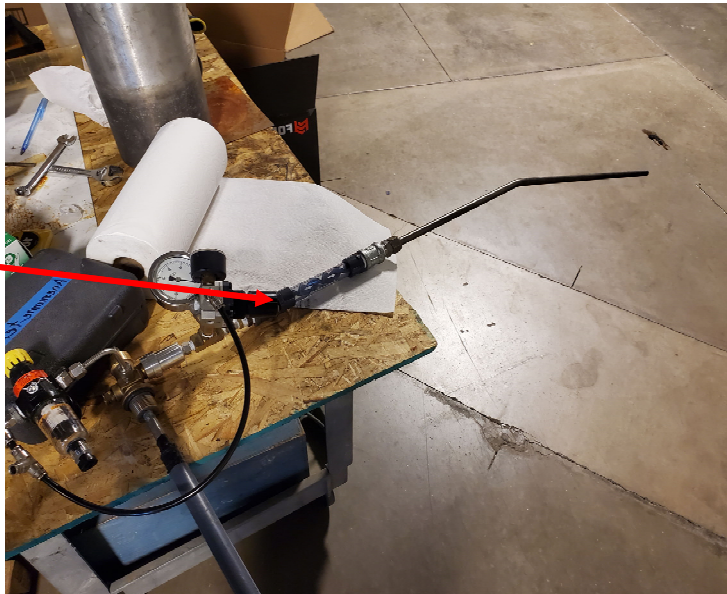

Pressurized nitrogen

Pressurized nitrogen

Surfactant mixture from tank



# Delivery System (12.5 ft<sup>2</sup> pan)



# Base formulation Components

- AGA – Alkylglucose Amide
- OSS – Organosiloxane Surfactant
- APG – Alkylpolyglucoside

Non-ionic

AGA

OSS

APG

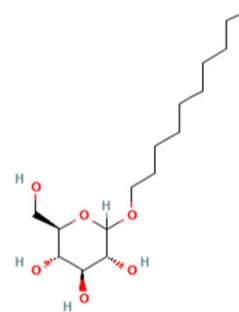
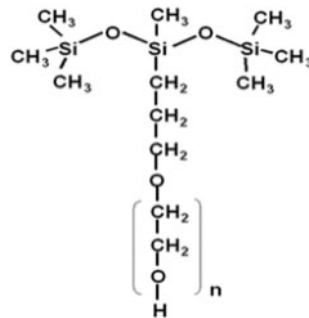
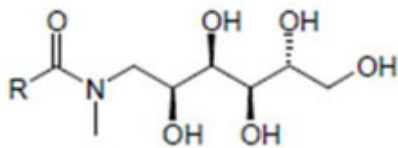

# Formulation List

	<b>AGA</b>	<b>OSS</b>	<b>APG</b>
Formulation A	40%	40%	20%
Formulation B	30%	60%	10%
Formulation C (pH 7)	30%	60%	10%
Formulation D (pH 7)	21.4%	42.9%	37.5%

# Results (Extinguishment)

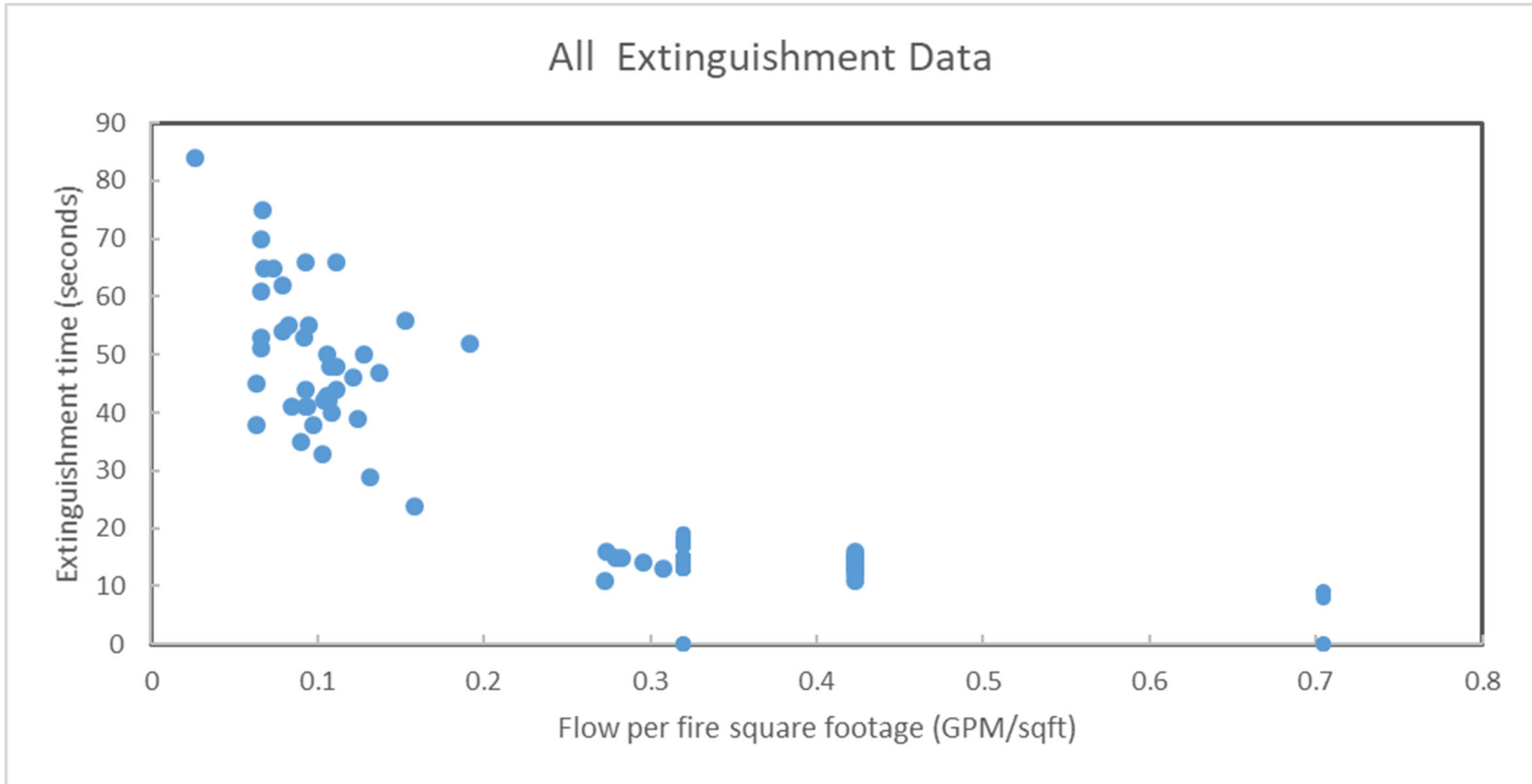

# Results (12.5 ft<sup>2</sup> pan)

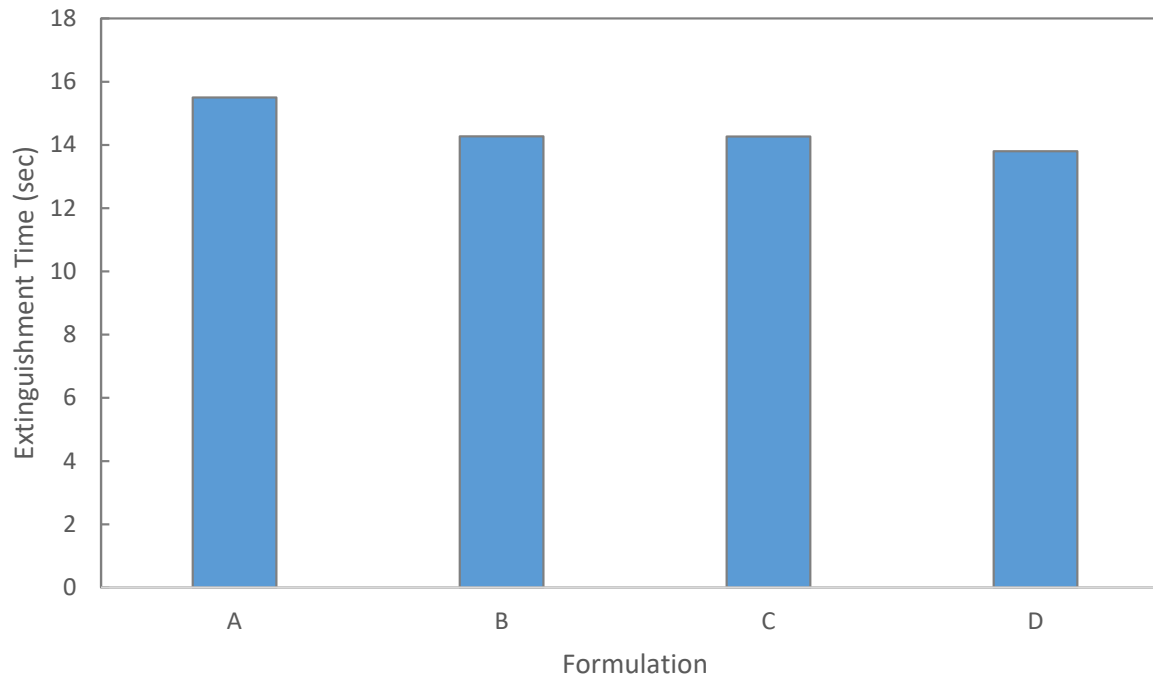

	AGA	OSS	APG
Formulation A	40%	40%	20%
Formulation B	30%	60%	10%
Formulation C (pH 7)	30%	60%	10%
Formulation D (pH 7)	21.4%	42.9%	37.5%

# Results (Burnback)

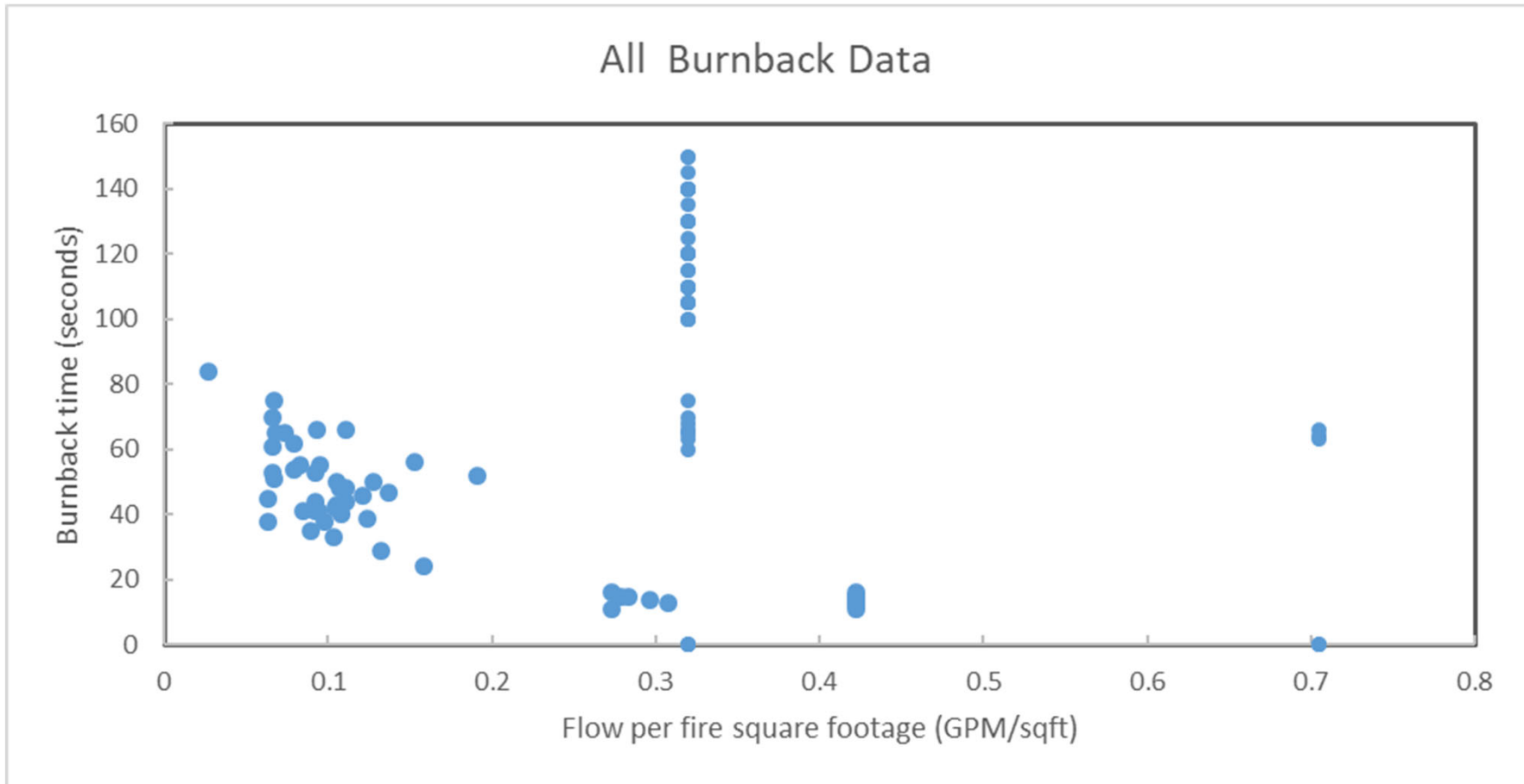

# Results (12.5 ft<sup>2</sup> pan)

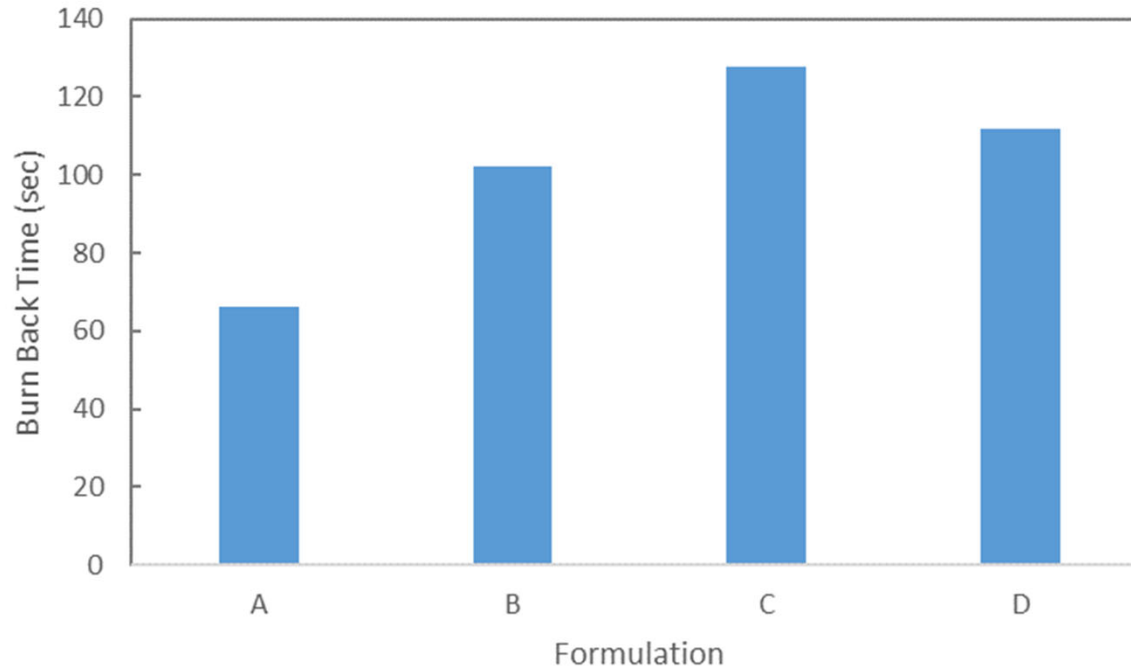

	AGA	OSS	APG
Formulation A	40%	40%	20%
Formulation B	30%	60%	10%
Formulation C (pH 7)	30%	60%	10%
Formulation D (pH 7)	21.4%	42.9%	37.5%

# Results (Surface Tension)

Component	Surface Tension (dynes/cm)
AGA	29
OSS	21
APG	30

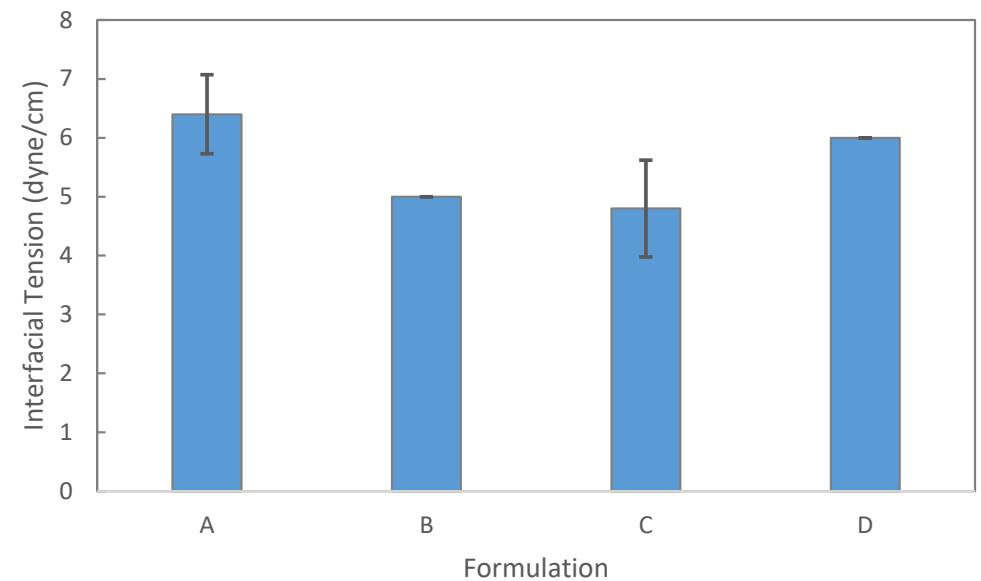
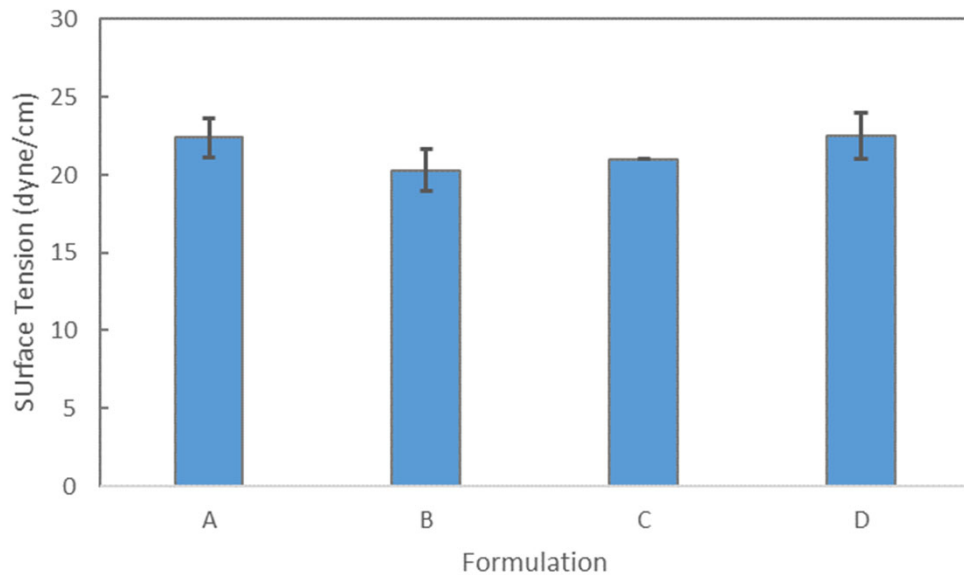

# Results (Spreadability)

$$S(t) = \gamma_{hc} - [\gamma_{foam} + \gamma_{foam/hc}]$$

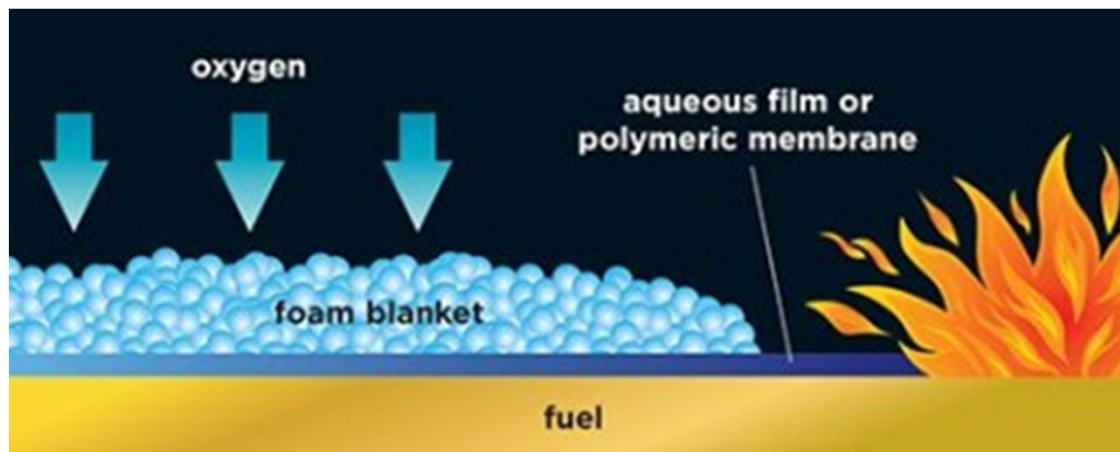

Formulation	Spreadability
A	$-7.8 \pm 1.9$
B	$-4.3 \pm 1.3$
C	$-4.8 \pm 0.8$
D	$-7.5 \pm 1.5$

# Results (Viscosity)

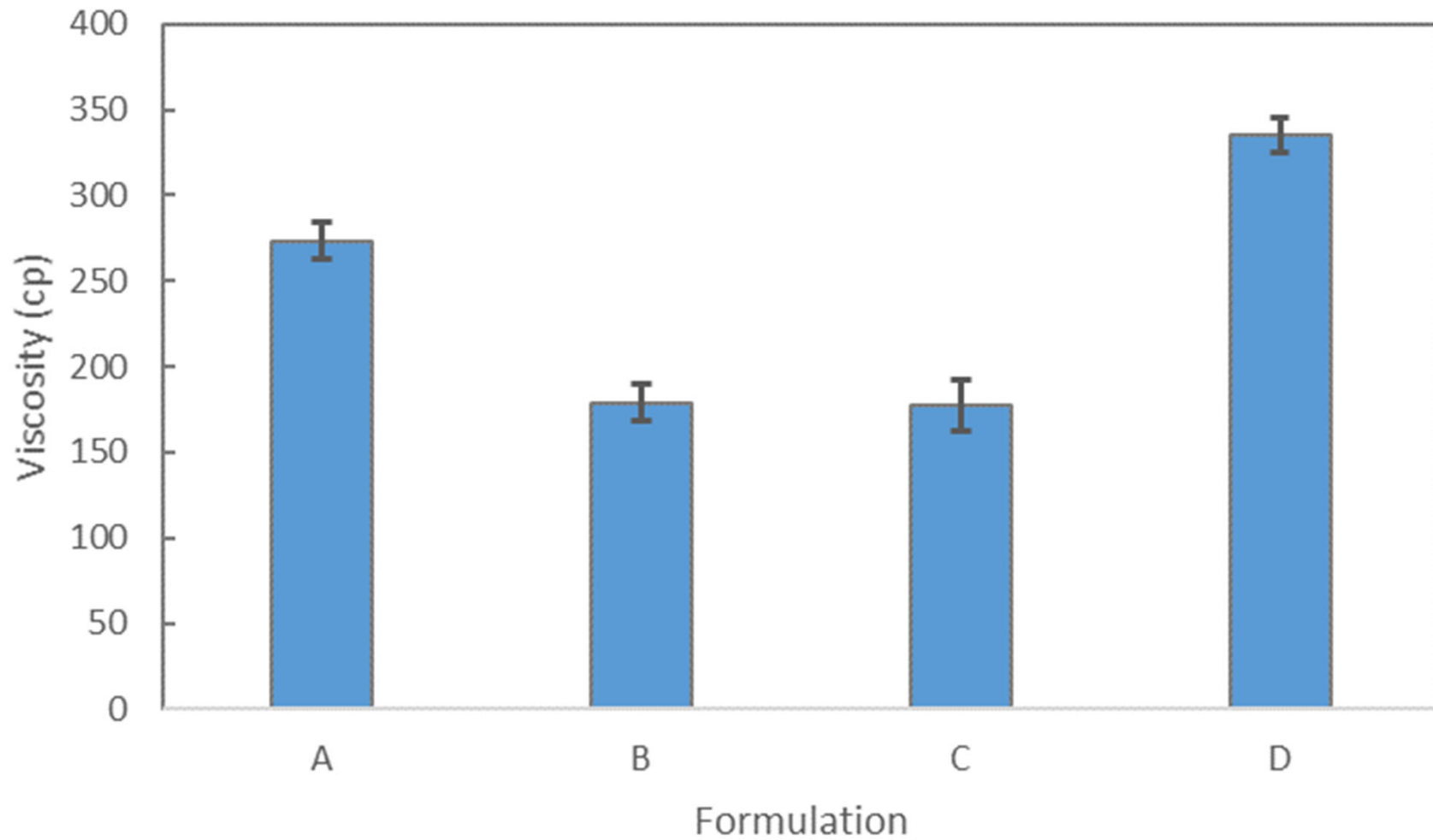

# Results (Drainage Time)

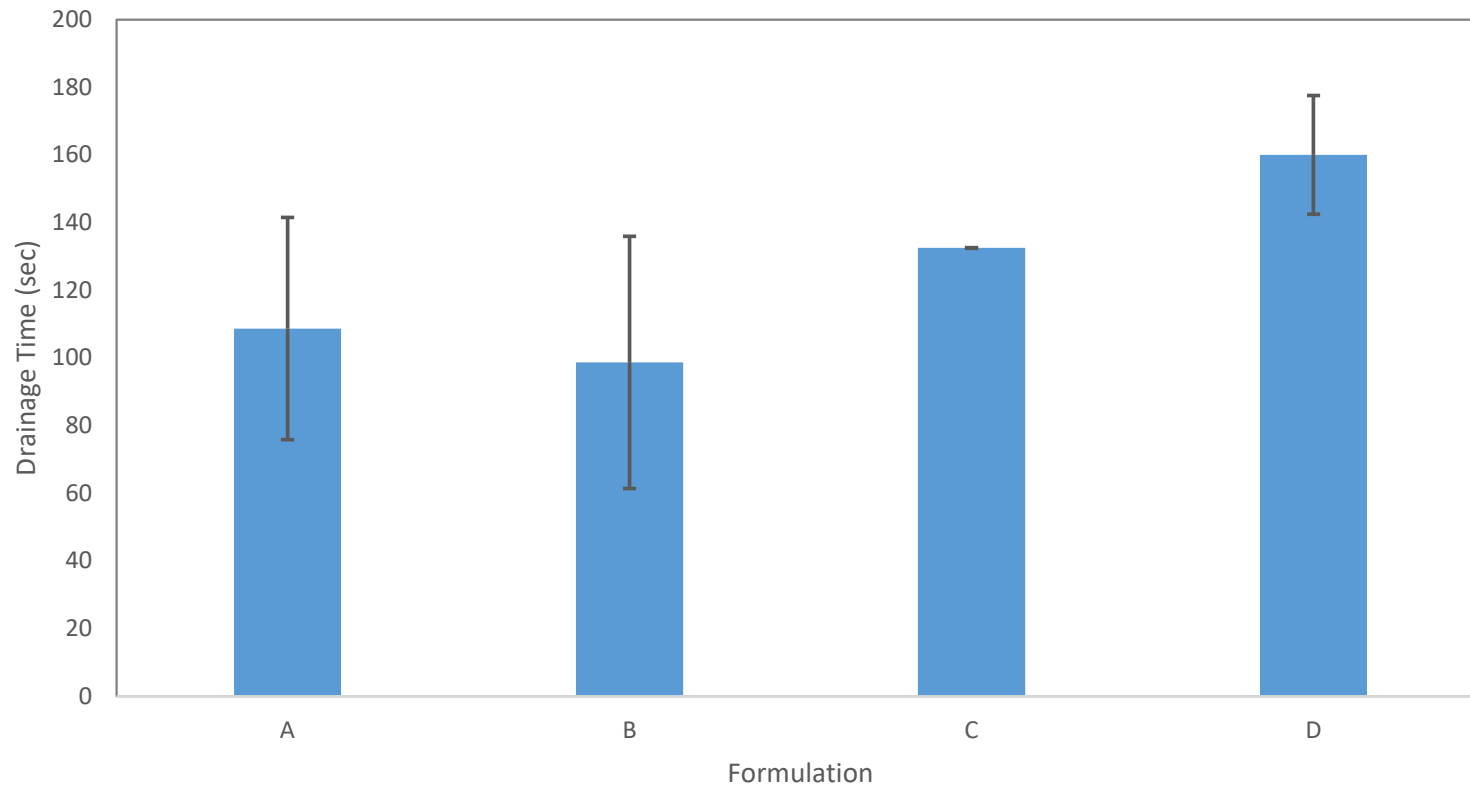

# Key Points

- Lower surface tension has diminishing returns on reducing extinguishment, but is directly proportional to improved burnback resistance.
- Film formation may still be possible even with negative spreading coefficient
- Delivery method is essential in determining extinguishment

Formulation	Extinguishment	Burnback	Spreadability	Expansion	Viscosity	Drainage
<i>[name]</i>	<i>[sec]</i>	<i>[sec]</i>	<i>[dyne/cm]</i>	<i>[ratio]</i>	<i>[cp]</i>	<i>[sec]</i>
A	15.5	66	-7.8	4.2	273	108
B	14.3	102	-4.3	4.1	179	98
C	14.3	127	-4.8	4.05	177	132
D	13.8	112	-7.5	4.43	334	160

# NRL Testing

Data from NRL		
Extinguishment:	61	sec
25% Burnback:	6:08	min:sec
Expansion Ratio:	4.2	n/a
25% Drain Time	7:31	min:sec



# Results: Film formation

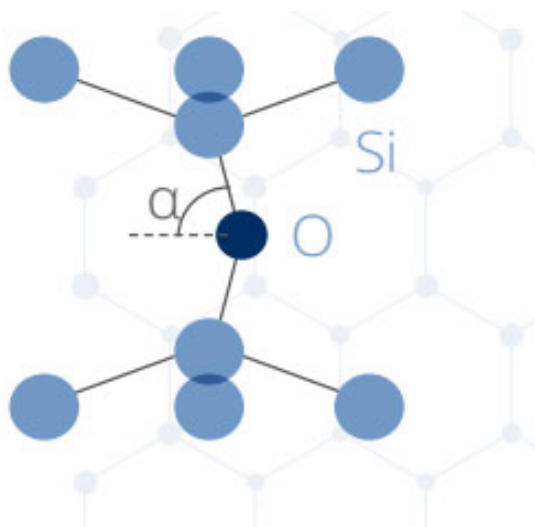

## ADA PFAS Free Fire Fighting Foams Commercialization Roadmap

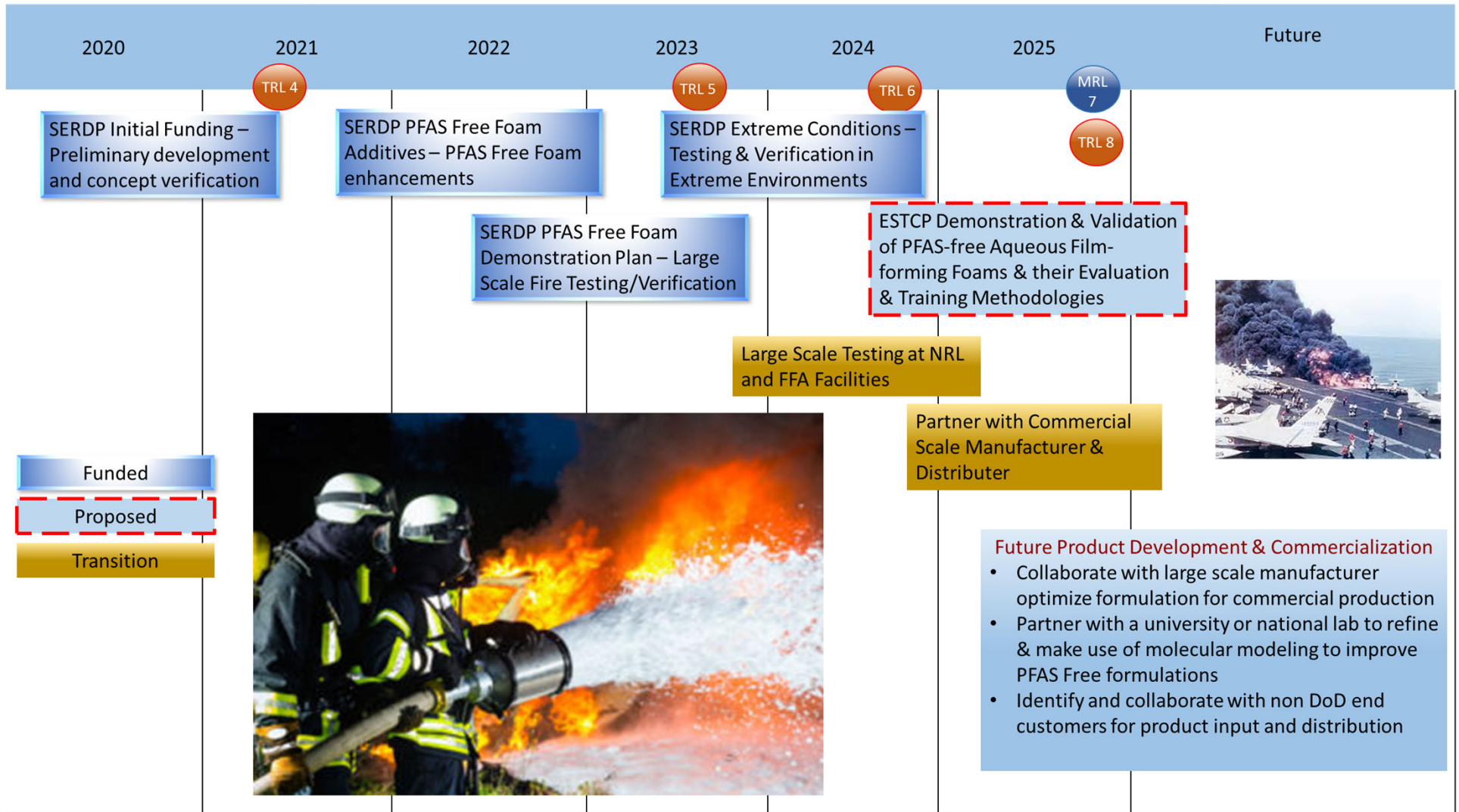

Funded
Proposed
Transition

ADA TECHNOLOGIES PROPRIETARY

# Remaining Unknowns

- Operational Conditions
- Aged Concentrate



**WP23-3920**

- Large Scale Validation
- Production Scale-up
- Market Identification
- System Integration

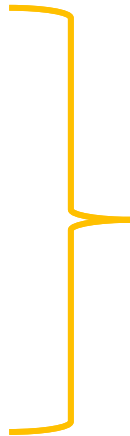

**WP24-B7-8102  
(on hold)**

- Corrosion Testing
- Formulation Compatibility

