

# REPORT DOCUMENTATION PAGE

Form Approved  
OMB No. 0704-0188

Public reporting burden for this collection of information is estimated to average 1 hour per response, including the time for reviewing instructions, searching existing data sources, gathering and maintaining the data needed, and completing and reviewing this collection of information. Send comments regarding this burden estimate or any other aspect of this collection of information, including suggestions for reducing this burden to Department of Defense, Washington Headquarters Services, Directorate for Information Operations and Reports (0704-0188), 1215 Jefferson Davis Highway, Suite 1204, Arlington, VA 22202-4302. Respondents should be aware that notwithstanding any other provision of law, no person shall be subject to any penalty for failing to comply with a collection of information if it does not display a currently valid OMB control number. **PLEASE DO NOT RETURN YOUR FORM TO THE ABOVE ADDRESS.**

<b>1. REPORT DATE (DD-MM-YYYY)</b>		<b>2. REPORT TYPE</b>	<b>3. DATES COVERED (From - To)</b>		
<b>4. TITLE AND SUBTITLE</b>			<b>5a. CONTRACT NUMBER</b>		
			<b>5b. GRANT NUMBER</b>		
			<b>5c. PROGRAM ELEMENT NUMBER</b>		
<b>6. AUTHOR(S)</b>			<b>5d. PROJECT NUMBER</b>		
			<b>5e. TASK NUMBER</b>		
			<b>5f. WORK UNIT NUMBER</b>		
<b>7. PERFORMING ORGANIZATION NAME(S) AND ADDRESS(ES)</b>			<b>8. PERFORMING ORGANIZATION REPORT NUMBER</b>		
<b>9. SPONSORING / MONITORING AGENCY NAME(S) AND ADDRESS(ES)</b>			<b>10. SPONSOR/MONITOR'S ACRONYM(S)</b>		
			<b>11. SPONSOR/MONITOR'S REPORT NUMBER(S)</b>		
<b>12. DISTRIBUTION / AVAILABILITY STATEMENT</b>					
<b>13. SUPPLEMENTARY NOTES</b>					
<b>14. ABSTRACT</b>					
<b>15. SUBJECT TERMS</b>					
<b>16. SECURITY CLASSIFICATION OF:</b>			<b>17. LIMITATION OF ABSTRACT</b>	<b>18. NUMBER OF PAGES</b>	<b>19a. NAME OF RESPONSIBLE PERSON</b>
<b>a. REPORT</b>	<b>b. ABSTRACT</b>	<b>c. THIS PAGE</b>			<b>19b. TELEPHONE NUMBER (include area code)</b>

# Final Scientific/Technical Report

## Executive Summary

This SBIR Phase II initiative culminated in successful field demonstrations of a prototype remote antenna system that meets both (a) C5ISR requirements for Alternate, Contingency, and/or Emergency use under a PACE (Primary, Alternate, Contingency, Emergency) tactical communications plan and (b) a long-standing stakeholder needs by the 101<sup>st</sup> ABN DIV for a permanent radio link between training ranges and headquarters facilities on Fort Campbell. (OV-1 and capability overviews have since been shared with the 101<sup>st</sup>.) Through multiple demonstrations of the prototype's rapid set-up, end-to-end function, and recovery processes with soldier participation at Fort Dix, NJ during Network Modernization Experiment 2023 (NMX23), it was proven that a plethora of radio frequency (RF) transmissions can be reliably remoted to distant antennas, thereby mitigating the risk of Command Post (CP) personnel being targeted via electromagnetic signatures. Smaller, lighter, less expensive, and with a larger range of operating frequencies than previous RF over fiber (RFoF) remote antenna solutions, the demonstrated technology can support HF, VHF, UHF, SATCOM, WIFI, and cellular communications – all waveforms and modulation schemes – up to 40 GHz. Because the Army's current tactical radio systems (e.g. Harris RT-1694/PRC-150 radio and associated amplifier) employ proprietary control signals, commercial-off-the-shelf (COTS) radio transceivers and amplifiers were used to demonstrate the RF transport capability. As an added value and to give the Army options for remoting RF traffic without regard for proprietary control signals – possibly making this Phase II solution agnostic to *any* equipment manufacture's proprietary messaging schemes – the contractor developed a digital-control-to-analog-transport converter that, as of this writing, appears to be effectively relaying the proprietary Harris control signals between the RT-1694 radio transceiver and RF-5833H amplifier over fiber. Further development of this manufacturer-agnostic command signal transport system would give the Army significant flexibility for future systems integration, including integrations unrelated to the remote antenna applications on which this Phase II was focused. The most timely and actionable outcome from this Phase II two initiative is likely the 101<sup>st</sup> ABN DIV's expressed interest in using a version of the remote antenna solution to address a long running problem they have experienced with communications on Fort Campbell's training ranges. In response to these requirements, the contractor developed an OV-1 and capability overview document that have since been shared with members of the 101<sup>st</sup>, further elevating the requesting unit's interest in installing a fixed or permanent version of the remote antenna system on Fort Campbell. As of this writing, the Army's technical point of contact for this Phase II is working with the SBIR office and other authorities to explore options for transferring this technology or, perhaps more simply, facilitating a routine purchase of a non-deployable version of the demonstrated solution for use on Fort Campbell.

## Company Overview

Cogitari Inc, a WOSB-SDVOSB, focuses on advancing communication technologies. With engineering experience that ranges from clandestine communications systems to multimodal intelligence collection platforms to cutting edge fiberoptic transceivers, and as the patent holder of a Radio Frequency (RF) Threat Detection System, the Cogitari team offers innovative, relevant, and cost-effective communication and signature management solutions to tomorrow's warfighter and intelligence operatives. Cogitari is headquartered in Bradenton, FL with satellite offices in Northern Virginia and near the Army's Redstone Arsenal.

**Principal investigator:** Mike Bishop, B.S Computer Science. 28 years research and development initiatives as a software engineer, systems architect, and program manager supporting DoD.

**RF Network engineer:** Andy Zwirko, B.S Electrical Engineering. 35 years' experience in network and RF systems design and development for the IC and DoD.

**Program Manager:** Gerry Heerink, 33 years' experience as a Program Manager, Technical Operations Officer supporting the IC and DoD.

## SBIR Phase II Overview

Cogitari [contractor] received an Army SIBR Phase II award (W56KGU-22-C-0020) to enhance the US Army's tactical communications system in relation to remote antennas and radio frequency (RF) signature management. Specifically, the contractor was required to develop a Proof-of-Concept (PoC) rapidly deployable communications link for use between a Command Post (CP) and a remote antenna site that improves upon previous remote antenna solutions in several respects.

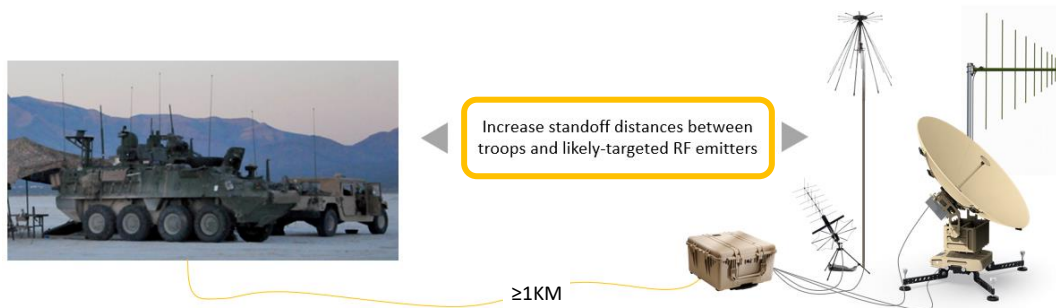

The primary objective for this Phase II effort defined by the Army's Technical Point of Contact (TPOC) and met by the contractor was to **improve the performance, security, and maintainability while reducing SWaP, emplacement and recovery times, and reduce overall operating cost** compared to prior RAS solutions.

The core RFoF system that was successfully demonstrated at Fort Dix, NJ during Network Modernization Experiment 2023 (NMX23) weighed only **10 lbs.** (4.5 kg) and was contained in a single NEMA enclosure measuring **13" × 15" × 7"** (330 mm x 381 mm x 178 mm), operated on 12 VDC, drew a mere 2 AMPs. Further reducing the solution's size and repackaging for seamless integration with the Army's C4ISR/EW Modular Open Suite of Standards (CMOSS) would be a logical next step.



*RFoF Transceiver used during NMX23 1*



*Proposed SBIR Phase III Chassis 1*

MILSPEC multi-core, fiberoptic cable and various reel/spool configurations were field tested and used with the PoC during the Phase II effort. Cable and reel assembly weights were a modest 68 lbs. (31 KG) for 1000m and 36 lbs. (16 KG) for 500m. System performances – all extremely favorable – are detailed in later sections of this report.



As with previous remote antenna solutions, the contractor's PoC offered increased force protection by separating Command Post personnel from antennas/emitters that could be detected and targeted by an adversary. While this reduction in Command Post (CP) RF/electromagnetic signature is common to virtually all remote antenna solutions, the PoC developed during this Phase II effort can offer several unique advantages over previous solutions, including:

**1. Optional Built-in Optical Time Domain Reflectometer (OTDR)**

ODTR is available via small form factor pluggable transceivers (SFP) with embedded micro-OTDR ( $\mu$ OTDR) capabilities. Used to automatically detect, locate, and report optical fiber faults, this capability will alert the CP, in real-time, if there is a fiber fault (cable break) within the deployed cable, greatly reducing mean-time-to-repair (MTTR) and improving network uptime and security.

**2. Optional Delta Power Sense (DPS or  $\Delta$ PS)**

The DPS function detects instantaneous optical power spikes (i.e. fast changes in optical power, up or down). Unlike the OTDR function, DPS will instantaneously report if a fiber cable is being manipulated or potentially compromised by adversaries attempting to tap the fiber. One way to detect fiber tapping is by noting increased attenuation added at the point of tapping but some tapping methods do not create sufficient attenuation and go unnoticed by current detection systems. DPS solves this problem.

**3. Built-in Ethernet**

Ethernet data connection between the sites with full SNMP and web GUI monitoring and control between sites allows commanders to run standard computer networks between the CP and the Remote Antenna site. Beyond the benefits of a distributed network, the ethernet connection permits the use of remote cameras or other surveillance equipment at the Remote Antenna site, increasing security and situational awareness.

**4. Built-in RS232**

For use with microcontrollers and remote sensors (including wireless and/or wired unattended ground sensors) to provide various sensing, reporting, and automated response functions.

Developed to be a component of the Army’s Primary, Alternate, Contingency, and Emergency (PACE) communications plan, the solution described herein is intended for Alternate, Contingency, or Emergency antenna remoting operations.

**SBIR OBJECTIVES: NEXT-GEN RFoF RAS**

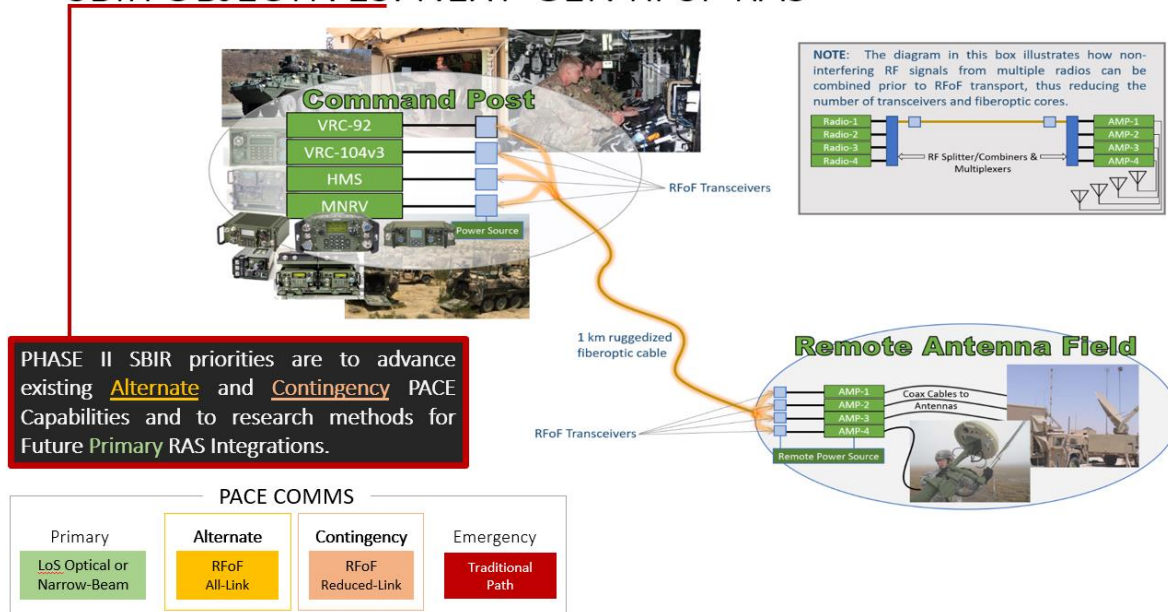

**Base Technology Overview**

The Radio Frequency over Fiber (RFoF) technology upon which this Phase II solution was developed is a well-proven technology that converts analog radio frequency (RF) signals to and from light for optical fiber transmission. The basic operation of RFoF is explained below.

- Modulation – In RFoF, a radio wave (RF) is converted into light by modulating the intensity of a light source (typically a laser) with the RF signal. This process is analog, meaning no digitization is involved.
- Transmission – The modulated light signal is transmitted over an optical fiber cable. The PoC developed under this Phase II used a MILSPEC multi-core, single mode fiberoptic cable that, while still lightweight and easily handled, has been demonstrated to survive the rigors of combat environments.
- Unlike traditional all-electrical signal transmission, RFoF offers several advantages, including:
  - Lower Transmission Losses – Signals transmitted over optical fiber experience significantly less attenuation (loss) compared to other media like metal cables or wireless transmission.
  - Reduced Sensitivity to Noise and Interference – Optical fiber is less susceptible to electromagnetic interference, ensuring cleaner signal transmission.
  - Compared with RF coaxial cables, optical fiber cables can be thinner and possibly more flexible, making it easier to lay them down in the field, for example. Furthermore, the cost per meter of cable can be substantially lower.
  - Security against signal interception and cable-breaks

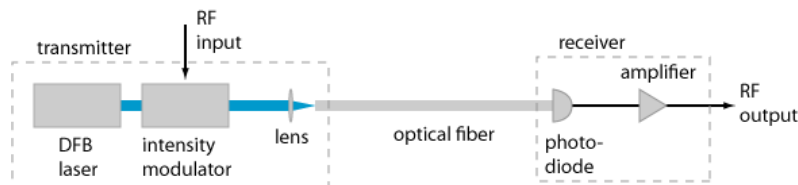

### Design and Field Demonstration of Proof of Concept (POC)

In discussion with the Army Technical Point of Contact (TPOC), it was determined that the Phase II PoC to be demonstrated as part of C5ISR's Network Modernization Experiment 2023 (NMX23) would feature an RFoF transport system operating in the High Frequency (HF) and Very High Frequency (VHF) ranges between 2 MHz and 60 MHz. Because the Army's currently fielded tactical radio sets employ proprietary control signals, a microcontroller-based solution was developed by the contractor to broker RS-232 control signals between the CP's radio transceivers and remote antenna site's RF power amplifier.

The equipment used in the PoC is designed for applications that demand very high spurious-free dynamic range (SFDR) and a low noise floor (NF). The Laser Diodes in the modules are temperature controlled, with a thermoelectric cooler (TEC) assuring a high level of RF performance and fixed gain over a wide range of ambient temperature variations. Mean time to failure (MTTF) currently exceeds 10 years at +50°C (122°F).

The following major equipment components were used for the RFoF RAS Proof of Concept:

- RFoF transceivers
  - 2 x Optical Zonu OZ810 high performance broadband optical transceiver

- Radios (commercial)
  - ICOM IC-705 - ICOM IC-705 HF/50/144/430 MHz All Mode Portable Transceiver
  - ICOM IC-7300 HF Plus 50 MHz Transceiver
  - ICOM IC-9700 VHF/UHF/1.2 GHz Transceiver
  - AnyTone AT-D578UV III Plus Tri-Band VHF/UHF/DMR Mobile Transceivers
- Amplifiers (commercial)
  - KXPA100-AT-F\_KXPA100-AT 100W Ext Amp with KXAT100 100W ATU
  - Xiegu XPA125B | 100W Power Amplifier

#### CP Base RFoF Parts List

- 2 – OZC fiber transceiver A03-Z810-D31-AS-SR (3 GHz, 1310nm, SC/APC, Single mode, RS232, 12V)
- 1 – OCC MTMAx0Bz1CA MHC T2 4CH Plug to 4 SC-M single mode 3' fiber cable assembly
- 2 – Diac SP3T-100C0612 - 3 port SMA-F RF Relay
- 2 – Pacific Antenna RF Sense Relay PCB
- 2 – SMA-F T adapters
- 2 – ZDtech 20 dB SMA M-F attenuator
- 2 – ZDtech 30 dB SMA M-F attenuator
- 1 – JANEL 1-1000 MHz 2:1 BNC-F RF splitter
- 3 – BNC-M to SMA-F adapters
- 1 – ANTRONIX 1-1000 MHz 2:1 F-F RF splitter
- 3 – F-M to SMA-F adapters
- 2 – 3" SMA-M to SMA-M RG-316 coax cable
- 6 – 12" SMA-M to SMA-M RG-316 coax cable
- 2 – 12" SMA-M to N-F RG-316 coax cable
- 2 – HiLetgo Dual Channel 12V Relay Module with Optocoupler PCB
- 2 – Maxmoral LM2596S DC-DC Step Down Variable Volt Regulator Input 3.0-40V Output 1.5-35V
- 1 – 12V DC 12.5 Amp IP67 Power Supply Adapter 100V-260V AC
- 4 – 12V 5A DC Power Barrel M-F Connector Cable DC Connectors 2.1mm x 5.5mm
- 4 – 1n4001 diodes
- 2 – DB9-F connectors
- 2 – 1/8" mini 2 channel cables

#### MCP Remote RFoF Parts List

- 2 – OZC fiber transceiver A03-Z810-D31-AS-SLR (3 GHz, 1310nm, SC/APC, Single mode, LNA, RS232, 12V)
- 1 – OCC MTMAx0Bz1CA MHC T2 4CH Plug to 4 SC-M single mode 3' fiber cable assembly
- 2 – Rankomu 3.2W RF 1MHz-700MHz Power Amplifier
- 2 – Diac SP3T-100C0612 - 3 port SMA-F RF Relay
- 2 – ZDtech 20 dB SMA M-F attenuator
- 4 – 6" SMA-M to SMA-M RG-316 coax cable
- 2 – 12" SMA-M to SMA-M RG-316 coax cable
- 6 – 12" SMA-M to SMA-M RG-316 coax cable
- 2 – 12" SMA-M to N-F RG-316 coax cable
- 2 – HiLetgo Quad Channel 12V Relay Module with Optocoupler PCB
- 2 – Maxmoral LM2596S DC-DC Step Down Variable Volt Regulator Input 3.0-40V Output 1.5-35V

- 1 – 12V DC 12.5 Amp IP67 Power Supply Adapter 100V-260V AC
- 2 – DB9-F connectors
- 2 – RCA-F cables

In addition to the above equipment that was purchased under this Phase II, the contractor also received a Harris RT-1694 radio, Harris RF-5833H Amplifier as Government Furnished Equipment (GFE). Due to This GFE equipment was not used in the PoC demonstration but was analyzed to determine the control signals between the radio and the amplifier for future (possible extended Phase2) demonstration.

Based upon the agreed requirements, with the TPOC for the demonstration of the PoC, the contractor developed a technical solution comprising of a Command Post and Remote Antenna Site RFoF units. The two units are connected with a fiber Optical cable to transport the signal.

The field test demo comprised of a Command Post (CP), the Remote Antenna Site and a Validation Verification Post (VVP). While the CP and Remote Antenna Site each contained components of the PoC, the VVP was equipped only conventional radios and antennas and, as such, was used to (1) confirm the solution's interoperability with conventional non-RFoF-equipped radio systems and (2) receive, transmit, and document RF traffic as part of the field experiment's test procedures.

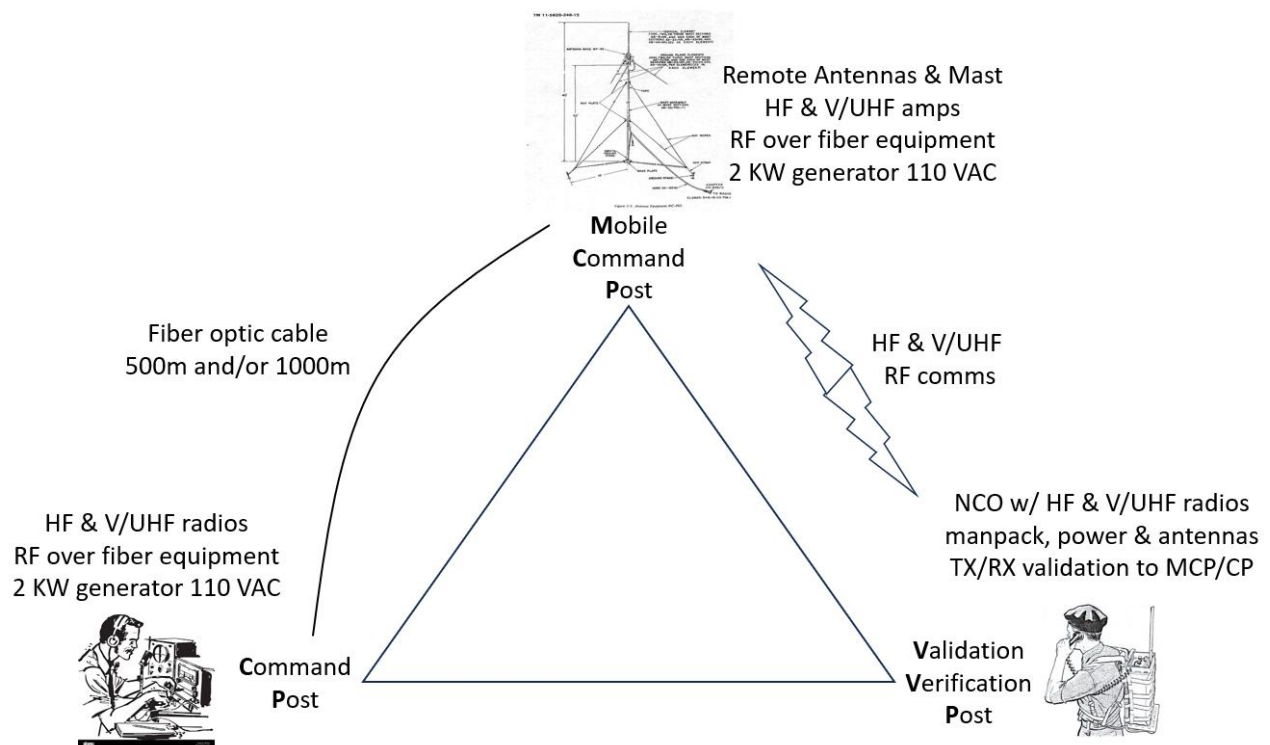

Command Post equipment included:

- 1 – 110VAC 2KW Honda generator and power cord extensions
- 1 – Astron 110VAC to 12VDC 30A power supply
- 1 – Icom IC-705 HF (3-54 MHz) manpack portable radio
- 1 – Icom IC-9700 V/UHF (144-148/430-450 MHz) base station radio

- 2 – 10' LMR-240 N-N coaxial cables
- 2 - Optical Zonu A03-Z810-D31-AS-SR (0-3 GHz Fiber transceivers)
- 1 - Cogitari designed RF signal conditioning, sensing, and switching system
- 1 - OCC 500m & 1000m 4-core single mode fiber (Military Tactical Fiber Optic Cables for Extreme Environments) with Tactical Fiber Optic Connector, COTS-83526
- 1 - OCC Modular Advanced Reel System (MARS) Reel (2 x, both for 500 and 1000-meter)
- 1 - OCC MARS® Transit Case with Acquisition Cradle (2 x, both for 500 and 1000-meter pool)

Below is the schematic for the CP RFoF module:

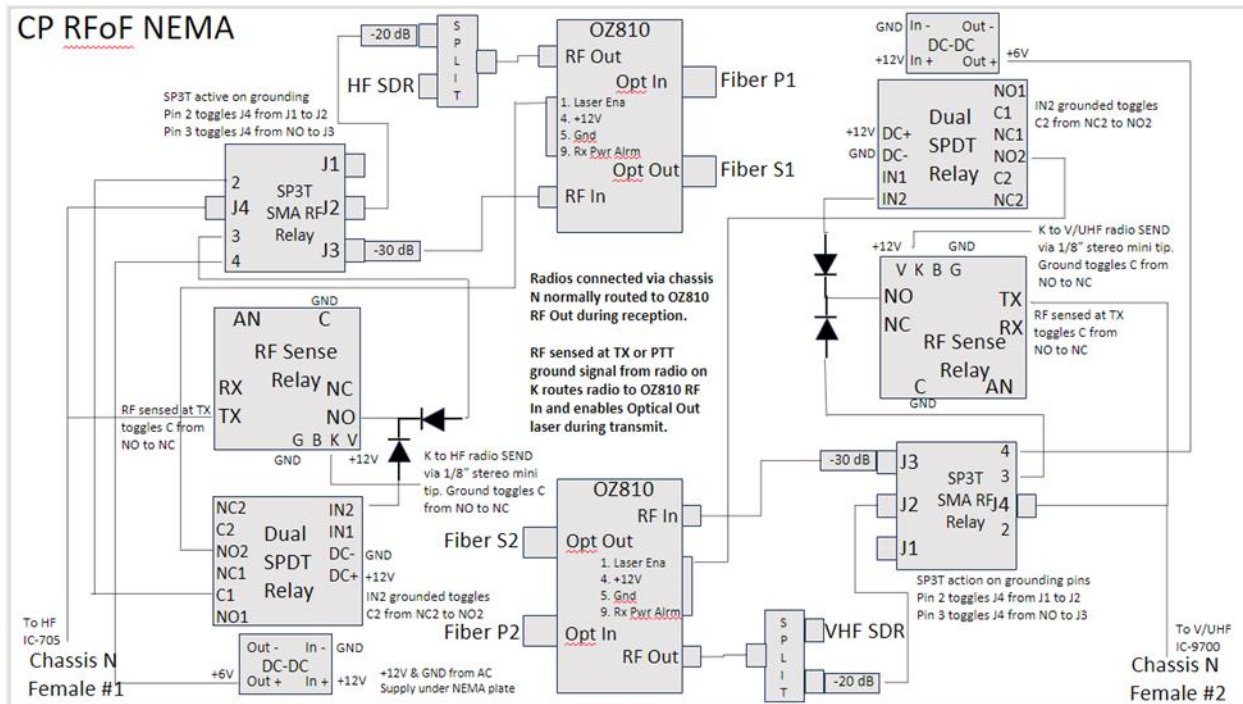

Remote Antenna Site equipment included:

- 1 – 110VAC 2KW Honda generator and power cord extensions
- 1 – Astron 110VAC to 12VDC 30A power supply
- 2 - Optical Zonu A03-Z810-D31-AS-SLR (0-3 GHz fiber transceivers with LNA)
- 1 - Cogitari designed RF signal conditioning, sensing, and switching system
- 2 – 10' LMR-240 N-N coaxial cable
- 1 – Elecraft KXPA100 HF (3-54 MHz) amplifier
- 1 – MFJ BD-35 V/UHF (144-148/430-450 MHz) amplifier
- 1 – 75' RG8X PL259-PL259 coaxial cable
- 1 – 25' RG8X PL259-PL259 coaxial cable
- 1 – Chameleon EMCOMM-III-P HF End Fed Half Wave 1.8-54 MHz wire antenna
- 1 – 18' Blue Sky Tripod Mast
- 1 – Diamond X30A 144-148/430-450 MHz vertical colinear antenna

Below is the schematic of the remote antenna site's RFoF module:

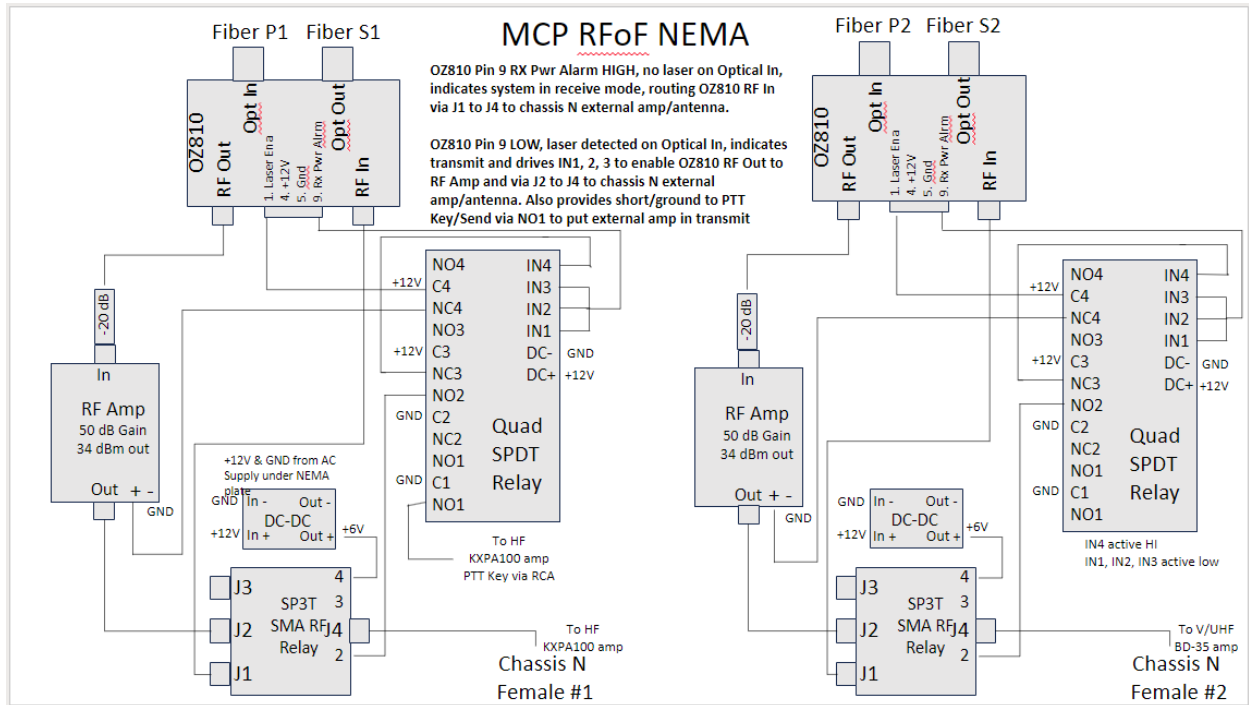

Validation Verification Post equipment included:

- 1 – 110VAC 2KW Honda generator and power cord extensions
- 1 – Astron 110VAC to 12VDC 30A power supply
- 1 – Icom IC-7300 HF (3-54 MHz) base station radio
- 1 – Anytone AT-D578UV III+ (144-148/430-450 MHz) vehicular radio
- 1 – 75' RG8X PL259-PL259 coaxial cable
- 1 – 25' RG8X PL259-PL259 coaxial cable
- 1 – MFJ-1919ex Tripod + MFJ-2982 33' vertical HF portable antenna
- 1 – 15' Portable Fiberglass Tripod
- 1 – Diamond X30A 144-148/430-450 MHz vertical colinear antenna

To connect the CP and the field RFoF units, the contractor used tactical Fiber optical cables and tactical optic connectors from Optical Cable Corporation (OCC). Photos of cable segment and connectors follow.



Two lengths of the fiber cable were deployed during the field demonstration. A 1000-meter cable and a 500-meter cable. Both cables came on the OCC Modular Advanced Reel System (MARS) Reel and in the OCC MARS Transit Case with Acquisition Cradle. See pictures below:



### NMX23 Test Procedures

The setup, configuration and operating procedures followed during the field test include:

- Configuration of the RF over Fiber system, radios, amplifiers, antennas:
  - 2 separate systems to support simultaneous HF & V/UHF communications
  - CP IC-705 HF RF output power 500mw (27 dBm) to 3w (35 dBm)
    - Analog voice USB (Upper Side Band) [emission 2K80J3E]
    - Analog voice FM (Frequency Modulation) [emission 11K2F3E]
    - 8-GFSK (Gaussian Frequency Shift Keyed) FT8 [emission 2K80J2D]
    - WSJT-X software employed for FT8 encoding/decoding
    - SparkSDR employed for reception of multiple FT8 HF frequencies
  - CP IC-9700 V/UHF RF output power 500mw (27 dBm) to 4.5w (36 dBm)
    - Analog voice Frequency Modulation (FM) [emission 11K2F3E]
    - Audio Frequency Shift Keyed (AFSK) AX.25 [emission 11K2F2D]
    - Direwolf software employed for AX.25 APRS encoding/decoding
  - MCP Amplifiers
    - HF amplifier @ 20w (43 dBm)
    - V/UHF amplifier @ 20w (43 dBm)
  - MCP Antennas
    - HF antenna 65' long, 35' height (1-3 dB gain)
    - V/UHF antenna 4' long, 18' height (4 dB gain)
  - VVP Radios
    - HF IC-7300 @ 20w (43 dBm)
    - V/UHF AT-D578UV III+ @ 20w (43 dBm)
  - VVP Antennas
    - HF antenna 33' long, 0' height ground mounted (1 dB gain)
    - V/UHF antenna 4' long, 15' height (4 dB gain)
- Setup of test scenarios or experiments.
  - Local signal quality transmission and reception testing from CP to VVP
    - CP IC-705 <-> VVP IC-7300
      - HF 4, 7, 10, 14, 18, 21, 24, 29 & 54 MHz USB & FM voice
    - CP IC-9700 <-> VVP AT-D578UV III+

- V/UHF 148 & 430 MHz FM voice
  - Distance testing for both transmission and reception
    - CP IC-705 & SparkSDR <-> Worldwide receivers
      - HF 7, 10, 14, 18, 21, 24, 28 MHz 8-GFSK FT8 text messaging
    - CP IC-9700 <-> NJ receivers
      - VHF 144 MHz AFSK AX.25 APRS text messaging
  - 500m fiber spool deployment and recovery configurations
    - Transit-case cradle in SUV
    - Dismounted Inverted A-Frame (wheelbarrow)
  - 1000m fiber spool deployment and recovery configurations
    - Transit-case cradle in SUV
    - A-Frame in open-back HMMWV
    - Dismounted Inverted A-Frame (wheelbarrow)
- Safety protocols and precautions taken during testing.
  - Fiber optic laser equipment was not powered until after cables connected to equipment
  - RF antennas placed at 50 or more feet from any radio operator tables
  - 3-wire power surge protectors used on all 110VAC generators
  - Ground mounted colored, flags, ropes and cones placed around wires, stakes and tripods to prevent accidental tripping hazards
  - <5 MPH for manual deployment and recovery of fiber from SUV
  - <8 MPH for manual deployment and recover of fiber from HMMWV
  - Ground-guide for routing and cable layout/strain-relief during all vehicular operations

**Test Results**

The following results assess the quality and strength of RF signals transmitted and received over fiber. Additionally, power measurements at various points in the systems were recorded. The fiber optic cable retrieval and deployment system options were tested, and times noted.

Performance Metrics:

- **Signal Quality:**
  - A digit system R (Readability 1=distorted/unreadable - 5=clear) was used for all voice communications tests
- **Signal Strength:**
  - A digit system S (Strength 1=weakest – 9=strongest) was used for all voice communications tests between

2-way Voice (USB & FM) RF Tests from CP to VVP

Frequency (MHz)	Readability	Strength
4.000	5	9
7.300	5	9
10.150	5	9
14.350	5	9
18.168	5	9

21.450	5	9
24.980	5	9
29.700	5	9
54.000	5	9
148.000	5	9

## National Time Standard Voice (AM) Broadcast Receptions

Frequency (MHz)	Readability	Strength	Location
3.330	N/A	N/A	Ottawa, Canada (CHU)
5.000	N/A	N/A	Ft. Collins, CO (WWV)
7.850	4	5	Ottawa, Canada (CHU)
14.670	4	3	Ottawa, Canada (CHU)
15.000	5	5	Ft. Collins, CO (WWV)
20.000	2	3	Ft. Collins, CO (WWV)
25.000	4	5	Ft. Collins, CO (WWV)

- **Signal Noise Ratio:**

- The open source WSJT-X software was used for transmission and reception of digital text messages on the 7-28 MHz (HF)
- WSJT-X was configured to use the 8-GFSK modulation FT8 text messaging protocol for distance and SNR demonstrations. The following table summarizes all the reception reports received on Day 2 of the event. Distance in miles and SNR ranges -25 (weakest) to +30 (strongest).

MHz	Max Dist.	Min Dist.	Avg Dist.	Max SNR	Min SNR	Avg SNR	# Reports
7	741	59	395	16	-23	0	95
10	2505	910	1921	9	-23	-11	40
14	8054	59	2282	29	-24	-6	6259
18	3528	1545	2614	1	-22	-14	13
21	N/A	N/A	N/A	N/A	N/A	N/A	N/A
24	4721	4721	4721	-17	-17	-17	1
28	8041	1626	4507	16	-20	-15	12

- WSJT-X configurations provide for the uploading and sharing of distance and SNR metrics online via the PSKreporter mapping server.
- Worldwide radio stations employing WSJT-X and sharing configuration contributed to the event reports for FT8 transmissions originating from NMX23 on Day 2 of the event on the 10, 14, 18, 21, 24 and 28 MHz HF frequencies.

## 10 MHz 8-GFSK FT8 Worldwide Reception Reports of RFoF NMX23 Transmissions (Day 2)

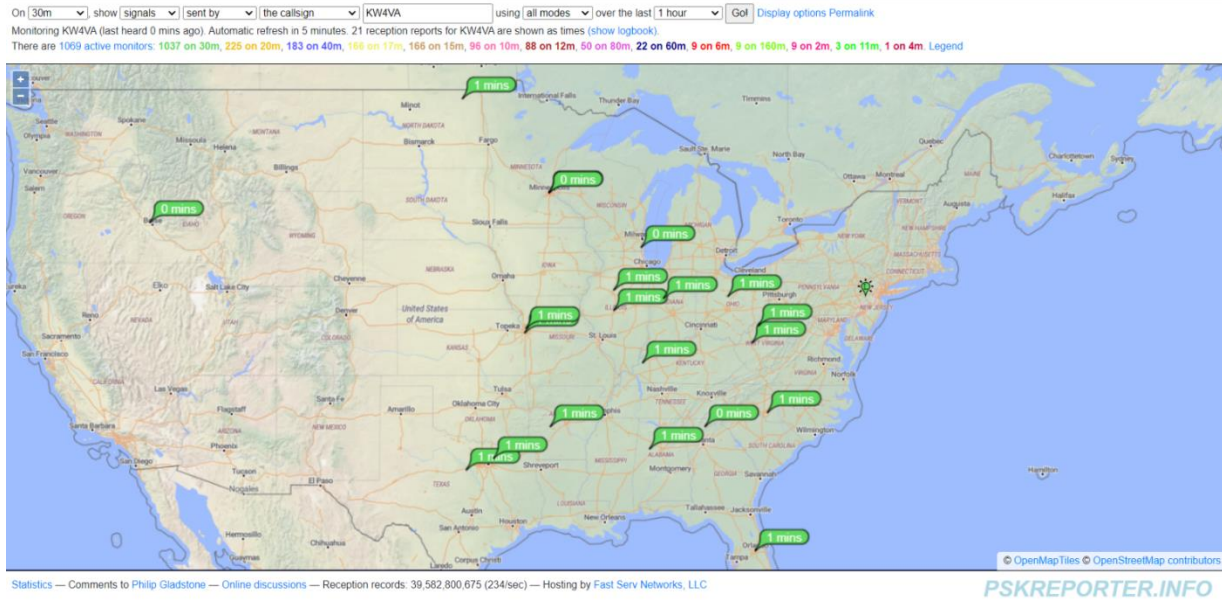

### 14 MHz 8-GFSK FT8 Worldwide Reception Reports of RFoF NMX23 Transmissions (Day 2)

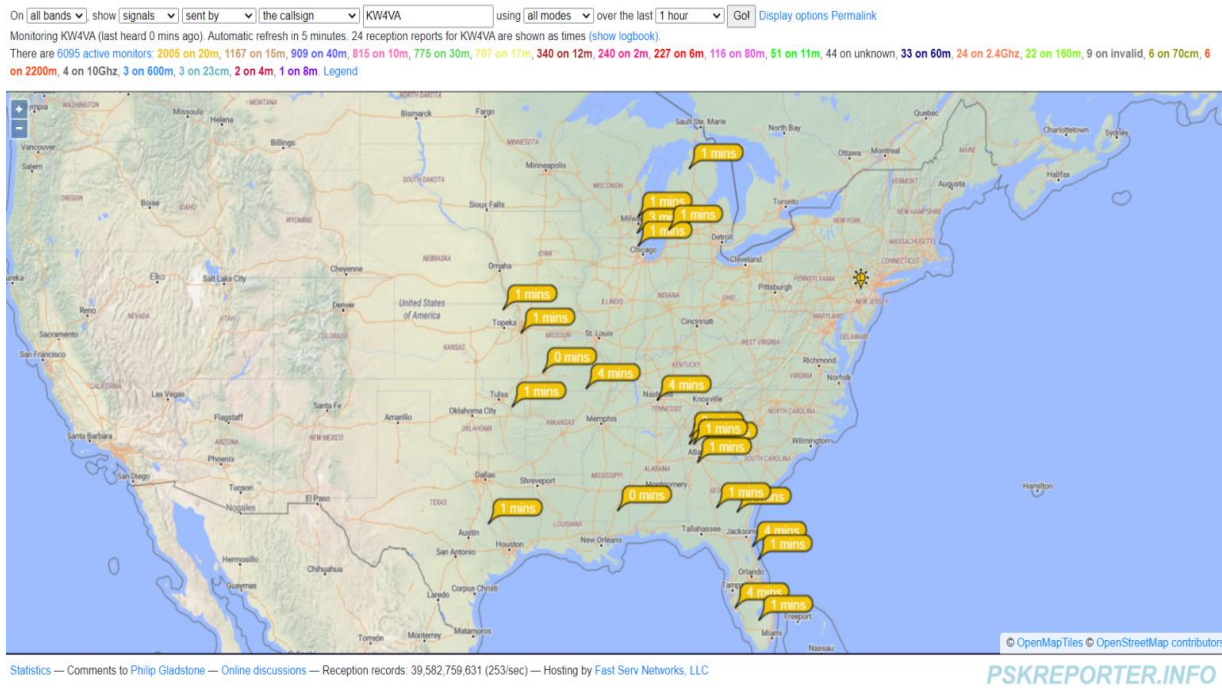

### 18 MHz 8-GFSK FT8 Worldwide Reception Reports of RFoF NMX23 Transmissions (Day 2)

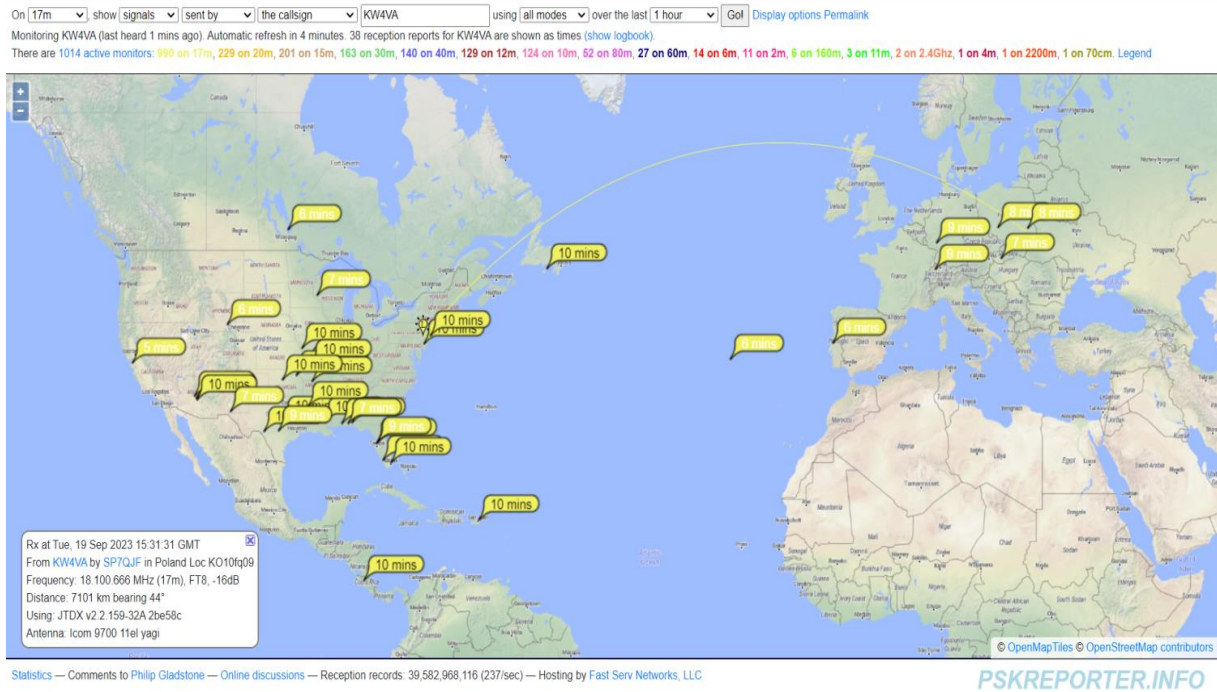

### 21 MHz 8-GFSK FT8 Worldwide Reception Reports of RFOF NMX23 Transmissions (Day 2)

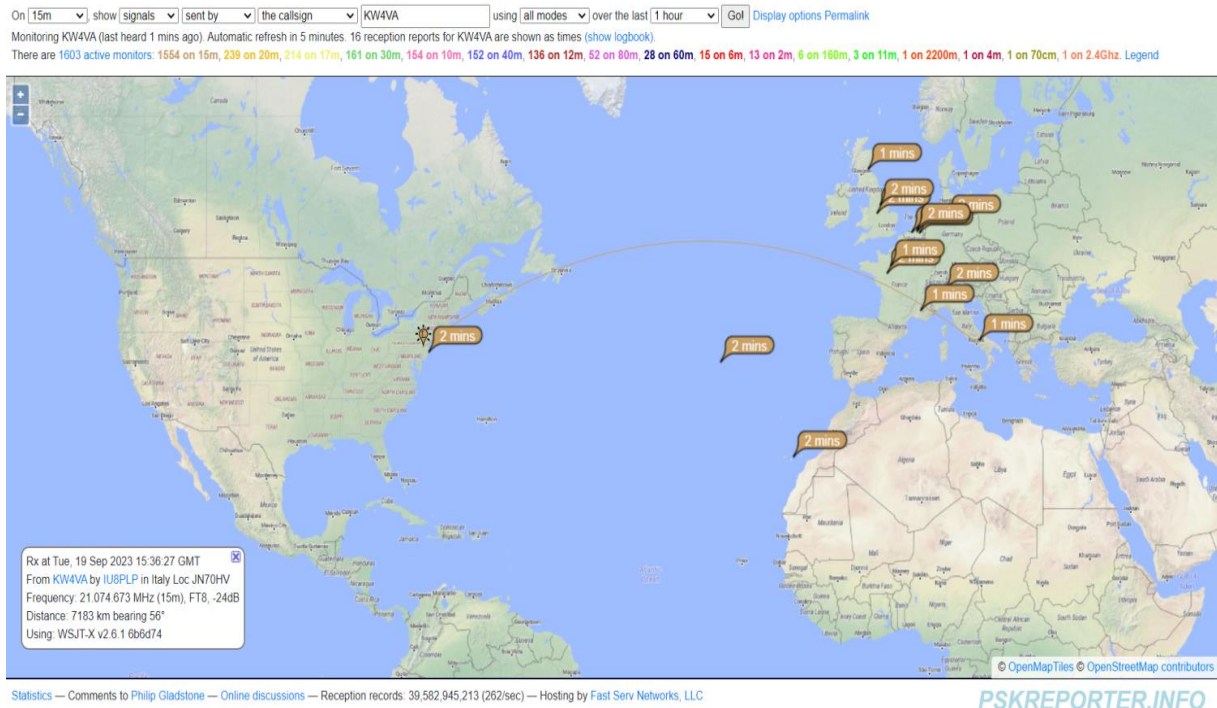

### 24 MHz 8-GFSK FT8 Worldwide Reception Reports of RFOF NMX23 Transmissions (Day 2)

On 12m show signals sent by the callsign KW4VA using all modes over the last 1 hour

Monitoring KW4VA (last heard 2 mins ago). Automatic refresh in 5 minutes. 7 reception reports for KW4VA are shown as times (show logbook).

There are 520 active monitors: 498 on 12m, 138 on 16m, 121 on 17m, 121 on 20m, 117 on 10m, 94 on 30m, 79 on 40m, 38 on 80m, 23 on 60m, 11 on 6m, 9 on 2m, 5 on 160m, 4 on 11m, 1 on 2200m, 1 on 2.4Ghz. Legend

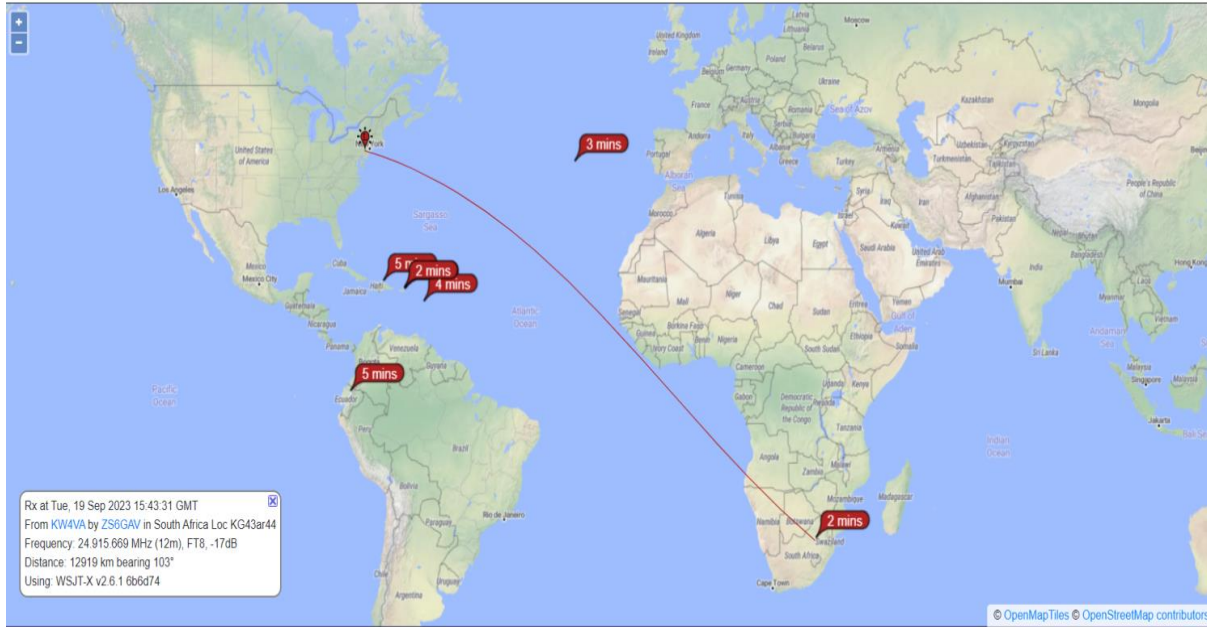

Statistics — Comments to Philip Gladstone — Online discussions — Reception records: 39,583,066,199 — Hosting by Fast Serv Networks, LLC

PSKREPORTER.INFO

### 28 MHz 8-GFSK FT8 Worldwide Reception Reports of RFoF NMX23 Transmissions (Day 2)

On 10m show signals sent by the callsign KW4VA using all modes over the last 1 hour

Monitoring KW4VA (last heard 1 mins ago). Automatic refresh in 5 minutes. 4 reception reports for KW4VA are shown as times (show logbook).

There are 1095 active monitors: 1064 on 10m, 170 on 15m, 168 on 20m, 137 on 17m, 124 on 12m, 100 on 30m, 96 on 40m, 38 on 80m, 24 on 60m, 18 on 2m, 17 on 6m, 4 on 160m, 3 on 11m, 1 on 2200m, 1 on 2.4Ghz. Legend

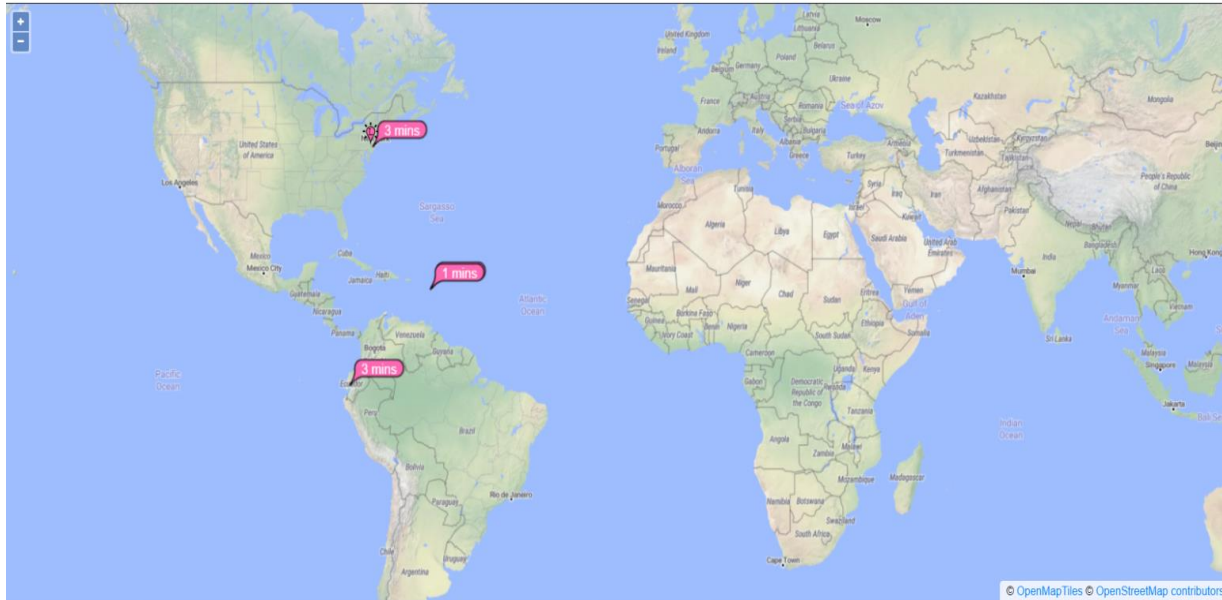

Statistics — Comments to Philip Gladstone — Online discussions — Reception records: 39,583,114,038 (206/sec) — Hosting by Fast Serv Networks, LLC

PSKREPORTER.INFO

### 144 MHz Reception Reports of AFSK AX.25 APRS Digital Message Packets from NJ stations

Station	Grid Locator	Miles
CHATSW	FM29RU	11.1
TOMRVR	FM29VX	17.2

- **Power Measurements:**

- dBm readings were measured using both a power meter and a spectrum analyzer for the CP RF radios and the MCP RF pre-amps and amplifiers for both HF and V/UHF systems

#### HF System Test Points (see Appendix CP Schematic)

Location/Device	dBm (max.)
CP/IC-705 OUT	35
CP/HF OZ810 IN	15
MCP/HF OZ810 OUT	-22
MCP/HF PREAMP OUT	30
MCP/HF AMP OUT	45

#### V/UHF System Test Points (see Appendix MCP Schematic)

Location/Device	dBm (max.)
CP/IC-9700 OUT	35
CP/VHF OZ810 IN	17
MCP/VHF OZ810 OUT	-17
MCP/VHF PREAMP OUT	30
MCP/VHF AMP OUT	43

- **Latency:**

- Demonstrations of removing and inserting the fiber optic cable from the CP RFoF unit were performed during CP to VVP voice communications tests and international AM broadcast reception tests. No latency was exhibited, and it was demonstrated that there was instantaneous loss and acquisition of the RF signals at the radios upon disconnection and reconnection of the fiber respectively.

- **Noise and Interference:**

- A geomagnetic storm impacted HF reception across all frequencies. The K-index (0 calm - 9 blackout) representing disturbance levels was reported as level 5.0 Day 1 and level 6.5 Day 2. This affected HF distance propagation reports as noted in the test results.

K-Indices for Sept 02-Oct 02 (note disturbance Sept 18-19)

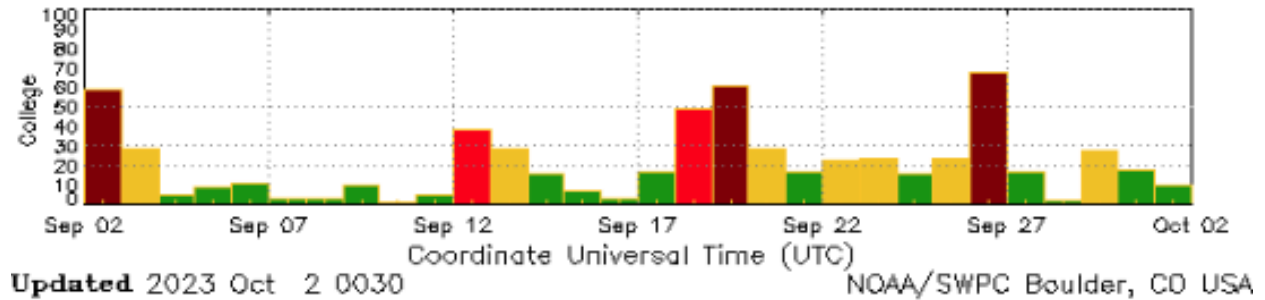

- Some unidentified, broad band buzzing interference was observed while tuning the HF spectrum for shortwave, AM, domestic and international broadcast stations. This was not noted during lab testing and was attributed to other RF emission experiments at NMX23.

### PoC Test Conclusion

The principal outcomes of the PoC's field test indicated that RF over Fiber (RFoF) transmitters (TX) and receivers (RX) could be successfully employed to transport multiple, low level (<30 dBm), analog and digital modulation transmission on frequencies of 3-54 MHz (HF), 144-148 MHz (VHF) and 430-450 MHz (UHF) while minimizing RF signal detectability at a Command Post (CP). RF signals were generated from radio transceivers consisting of a single and combined TX/RX antenna port located at a CP, converted to laser light (1310nm) and transported to a remote antenna location. It was revealed that RFoF equipment at a remote antenna and distant Mobile Command Post (MCP) connected via a 1000m, multi-core, fiber optic cable from the CP converted the laser light back to RF. The resultant RF at the MCP could then be amplified via external pre-amps and amplifiers and radiated via various antennas and used to communicate with both local and distant radio stations.

In direct support of the RFoF remote antenna capability demonstration, Cogitari also demonstrated and evaluated multiple fiber cable deployment systems manufactured by Optical Cable Company (OCC). Timed deployments and recoveries of 500m and 1000m fiber spools were conducted in two different vehicles (open-back HMMWV and a rented Sport Utility Vehicle, SUV) using OCC's transit-case cradle, A-frame, and inverted A-frame "wheelbarrow" spool support systems.

### SBIR Phase II Conclusion and Way Ahead

Since the prototype Remote Antenna System was demonstrated with COTS radios and amplifiers, an extended Phase II would allow the contractor's digital control converter to be tested with the GFE Harris RT-1694 radio and Harris RF-5833H Amplifier. Once successfully demonstrated, **the commercialization of this manufacturer-agnostic control signal converter would offer the Army significant flexibility for future systems integrations that extend beyond the remote antenna applications on which the initial Phase II was focused.**

A second body of work to be completed is to repackage the developed hardware and, if appropriate, standardize its physical form factor and electrical power requirements with the Army's C4ISR/EW Modular Open Suite of Standards (CMOSS).

Lastly but perhaps most the immediately viable follow-on activity could be to **address the 101<sup>st</sup> ABN DIV's long-standing need for a permanent or semi-permanent radio link between training ranges and headquarters facilities on Fort Campbell.** This requirement could be met under an extension to this Phase II or, perhaps more simply, as a direct purchase by Fort Campbell's Mission and Installation Contracting Command (MICC) based upon the configuration requirements. As the 101<sup>st</sup>'s requirement is for a non-deployable version of the contractor's existing commercially available technology – i.e., no different from any other commercial application of the RFoF technology – the required equipment and contractor support could possibly be procured by the MICC using discretionary funds and without the need for a formal technology transfer, materiel acquisition planning, or other steps associated with Programs of Record or Program Management.

For a Government TPOC reference, please reach out to Joe Lashine, 443-395-7460, [joseph.p.lashine.civ@army.mil](mailto:joseph.p.lashine.civ@army.mil)

For a Cogitari Inc. reference, please reach out to Gerry Heerink, 703.587.0616 [gheerink@cogitari.us](mailto:gheerink@cogitari.us)

--