



AFRL-AFOSR-VA-TR-2024-0019

Magnet-Free Non-Reciprocal Metamaterials Based on Spatio-Temporal Modulation

Andrea Alu
RESEARCH FOUNDATION OF THE CITY UNIVERSITY OF NEW YORK
85 SAINT NICHOLAS TER
NEW YORK, NY, 10031
USA

10/30/2023
Final Technical Report

DISTRIBUTION A: Distribution approved for public release.

Air Force Research Laboratory
Air Force Office of Scientific Research
Arlington, Virginia 22203
Air Force Materiel Command

REPORT DOCUMENTATION PAGE

PLEASE DO NOT RETURN YOUR FORM TO THE ABOVE ORGANIZATION.

1. REPORT DATE 20231030	2. REPORT TYPE Final	3. DATES COVERED	
		START DATE 20180715	END DATE 20230714
4. TITLE AND SUBTITLE Magnet-Free Non-Reciprocal Metamaterials Based on Spatio-Temporal Modulation			
5a. CONTRACT NUMBER	5b. GRANT NUMBER FA9550-18-1-0379	5c. PROGRAM ELEMENT NUMBER 61102F	
5d. PROJECT NUMBER	5e. TASK NUMBER	5f. WORK UNIT NUMBER	
6. AUTHOR(S) Andrea Alu			
7. PERFORMING ORGANIZATION NAME(S) AND ADDRESS(ES) RESEARCH FOUNDATION OF THE CITY UNIVERSITY OF NEW YORK 85 SAINT NICHOLAS TER NEW YORK, NY 10031 USA			8. PERFORMING ORGANIZATION REPORT NUMBER
9. SPONSORING/MONITORING AGENCY NAME(S) AND ADDRESS(ES) Air Force Office of Scientific Research 875 N. Randolph St. Room 3112 Arlington, VA 22203		10. SPONSOR/MONITOR'S ACRONYM(S) AFRL/AFOSR RTB1	11. SPONSOR/MONITOR'S REPORT NUMBER(S) AFRL-AFOSR-VA-TR-2024-0019
12. DISTRIBUTION/AVAILABILITY STATEMENT A Distribution Unlimited: PB Public Release			
13. SUPPLEMENTARY NOTES			
14. ABSTRACT The overall objective of our MURI program has been to introduce and develop revolutionary concepts to model, design, analyze, fabricate and characterize magnet-free non-reciprocal metamaterials for the next generation of integrated electromagnetic and photonic systems. Over the past three years, our team has been introducing an entirely new paradigm for nonreciprocal technology, pushing the limits in terms of efficiency, isolation, insertion loss, integrability, size, cost, noise, power handling and scalability. In the past five years, we have been addressing the fundamental issues currently limiting non-reciprocal metamaterial devices, in particular in the context of their bandwidth of operation and metrics of performance, opening completely new pathways towards integrated magnet-free technology that outperforms magnet-based isolators, circulators, gyrators and other relevant devices over all metrics of interest for various applications of relevance to the DoD, including radar, communications, quantum computing and nanophotonics. In parallel, we have also been opening a new paradigm in the context of metamaterial technologies based on temporal modulations, unveiling new wave phenomena in time-modulated metamaterials.			
15. SUBJECT TERMS			
16. SECURITY CLASSIFICATION OF:		17. LIMITATION OF ABSTRACT	18. NUMBER OF PAGES
a. REPORT U	b. ABSTRACT U	c. THIS PAGE U	UU 73
19a. NAME OF RESPONSIBLE PERSON ARJE NACHMAN			19b. PHONE NUMBER (Include area code) 426-8427

Standard Form 298 (Rev. 5/2020)
Prescribed by ANSI Std. Z39.18

AFOSR-MURI FY2019: Magnet Free Non-Reciprocal Metamaterials Based on Spatio-Temporal Modulation

FINAL REPORT

Period of performance: July 15, 2018 to July 14, 2023

I. Administrative information

Grant Number: FA9550-18-1-0379
Start Date: 15 July 2018
PI: Prof. Andrea Alù
Phone: 512-471-5922; Email: alu@gc.cuny.edu
Lead Institution: City University of New York
Program Managers: Dr. Arje Nachman, Dr. Gernot Pomrenke AFOSR/RTB1
Phone: 703-696-8427
Email: arje.nachman@us.af.mil, gernot.pomrenke@us.af.mil
Website: <https://afosr-muri.ws.gc.cuny.edu/>

II. Meetings

October 16, 2023, Advanced Science Research Center, CUNY, Final review meeting
September 23, 2022, Advanced Science Research Center, CUNY, 4th year review meeting
September 30, 2021, Online (zoom), 2nd - 3rd year review meeting
September 12, 2019, Advanced Science Research Center, CUNY, 1st year review meeting
September 7, 2018, Advanced Science Research Center, CUNY, Kick-off meeting

The third annual review meeting was performed over Zoom due to the COVID-19 pandemic restrictions. Slides, videos and outcomes of all our review meetings have been shared with the DoD personnel, and they are available upon request.

III. Program objective

The overall objective of our MURI program has been to introduce and develop revolutionary concepts to *model, design, analyze, fabricate* and *characterize* magnet-free non-reciprocal metamaterials for the next generation of integrated electromagnetic and photonic systems. Over the past three years, our team has been introducing an entirely new paradigm for non-reciprocal technology, pushing the limits in terms of efficiency, isolation, insertion loss, integrability, size, cost, noise, power handling and scalability. In the past five years, we have been addressing the fundamental issues currently limiting non-reciprocal metamaterial devices, in particular in the context of their bandwidth of operation and metrics of performance, opening completely new pathways towards integrated magnet-free technology that outperforms magnet-based isolators, circulators, gyrators and other relevant devices over all metrics of interest for various applications of relevance to the DoD, including radar, communications, quantum computing and

nanophotonics. In parallel, we have also been opening a new paradigm in the context of metamaterial technologies based on temporal modulations, unveiling new wave phenomena in time-modulated metamaterials.

IV. Scientific approach

To achieve these objectives, we have made advances in the following areas: *(i) a real-time-reconfigurable metamaterial platform* supporting novel phenomena that will push the boundaries of time-modulated systems, spanning a broad range of wavelengths from radio-frequencies to the visible; *(ii) novel theoretical tools*, including analytical and numerical methods, as well as fundamental bounds to various metrics of interest, capturing the involved complex physics at hand, such as parametric, nonlinear, quantum, topological and multi-physics phenomena; *(iii) new nanofabrication techniques* and *material platforms* to realize cost-effective, integrated, reconfigurable non-reciprocal metamaterials, including 2D materials, superconducting circuitry and opto-mechanics; *(iv) advances in the fundamental physics* of light-matter interaction in time-modulated metamaterials, using ad-hoc modeling, fabrication and characterization tools; *(v) new concepts for metamaterials*, such as applying parametric phenomena based on time-modulation, reconfigurability, and energy exchanges between harmonics, to push the boundaries of metamaterials to new regimes and functionalities.

Collaborating at the frontiers of metamaterials, integrated circuits, superconductors, 2D materials, opto-mechanics and quantum optics, we are working synergistically as a team to reveal groundbreaking phenomena beyond the proposed technologies to break reciprocity, significantly broadening the impact of our efforts. The combination of leading experts in modeling, fabrication and characterization of electromagnetic and photonic systems allows the team to explore the full extent the impact of the proposed concepts for several exciting applications of interest to the DoD and more broadly to our entire society, pushing the limits in electromagnetic signal manipulation, routing, processing and storage.

V. Team members

Our team is formed by the following PIs from CUNY, Stanford, Columbia and Michigan:

ASRC CUNY: Andrea Alù (PI)

Stanford U: Shanhui Fan
 Amir Safavi-Naeini

Columbia U: Michal Lipson
 Harish Krishnaswamy

U Michigan: Anthony Grbic

In addition, our efforts are supported by unfunded international collaborators:

EPFL: Tobias Kippenberg

Aalto: Sergei Tretyakov

VI. Financial execution

Provided below is the financial execution of the MURI project for the basic budget period to date:

MURI: FA9550-18-1-0379

Basic period:

Period 1: July 15, 2018 to July 14, 2019

Duration: 1 year

Budget: \$1.5M

Spent: \$794k

Period 2: July 15, 2019 to July 14, 2020

Duration: 1 year

Budget: \$1.5M

Spent: \$1,499,933.90

Period 3: July 15, 2020 to July 14, 2021

Duration: 1 year

Budget: \$1.5M

Spent: \$1,739,188.86

Option period:

Period 4: July 15, 2021 to July 14, 2022

Duration: 1 year

Budget: \$1.5M

Spent: \$1,621,592.21

Period 5: July 15, 2021 to July 14, 2022

Duration: 1 year

Budget: \$1.5M

Spent: \$1,845,285.03

Our team has underspent in the first year, spent as expected in the second year, and caught up on the spending in the third year and option period. This delay in spending was due to the pandemic impact. COVID-19 has indeed had a major impact on our effort. As expected, we have been able to fully catch up on the spending as the effort has continued, and achieve our goals of the program within the five years. We have spent all the available budget by the end of 5th year.

VII. Research highlights

Our MURI team has been organized along 4 major thrusts, schematically shown in Fig. 1, together with the interactions among PIs (initials correspond to the different PIs):

- (1) Theoretical framework and fundamental bounds of time-modulated, non-reciprocal systems for signal transport
- (2) Radio-frequency guided waves and radiation
- (3) Nanophotonic circuits and systems
- (4) New physical principles to drive signal manipulation, routing, processing and storage using time-modulated metamaterials

Across these five years, our team has made significant progress along each of these thrusts, developing exciting new ideas in the context of time-modulated metamaterials and implementing new devices and technologies that hold the promise to push forward various technologies of interest to DoD. In the following, we summarize and review a selection of research accomplishments and highlights that have contributed to the success of this program, with a particular focus on the last year of effort, given that previous interim reports are available upon request. More details can be found in our journal publications, detailed towards the end of this report, which further expand on the topics discussed in the following sections.

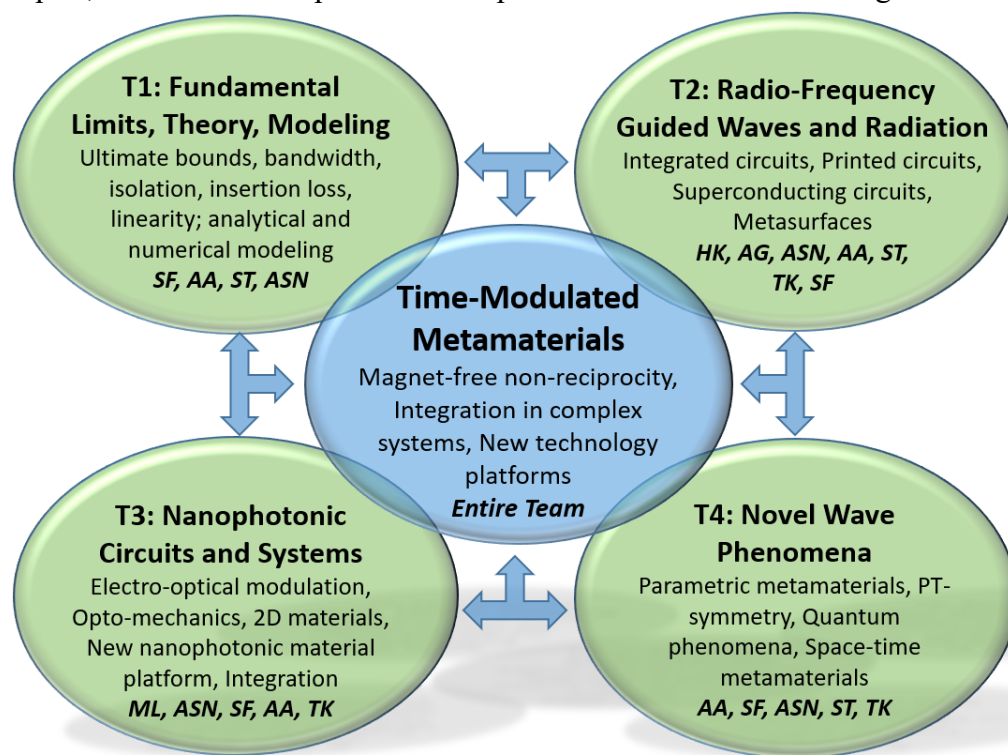

Figure 1 – Schematics of thrust interactions for our MURI effort

Thrust 1, 4: Fundamental limits, theory and modeling and novel wave phenomena

Our first thrust has been focusing on advances in the theory, modeling and simulations of time-varying metamaterials, and on understanding the fundamental limits of operating driven electromagnetic systems. We have been discovering several new bounds for the operation of absorbers, frequency mixers, non-reciprocal technologies, which hold the promise to advance our technologies at the highest level. For details on all these advances, the interested reader is referred to our list of publications in the Appendix below.

As a summary, Figure 1 provides a historical picture and reviews the basic concepts in the field of time-varying metamaterials.

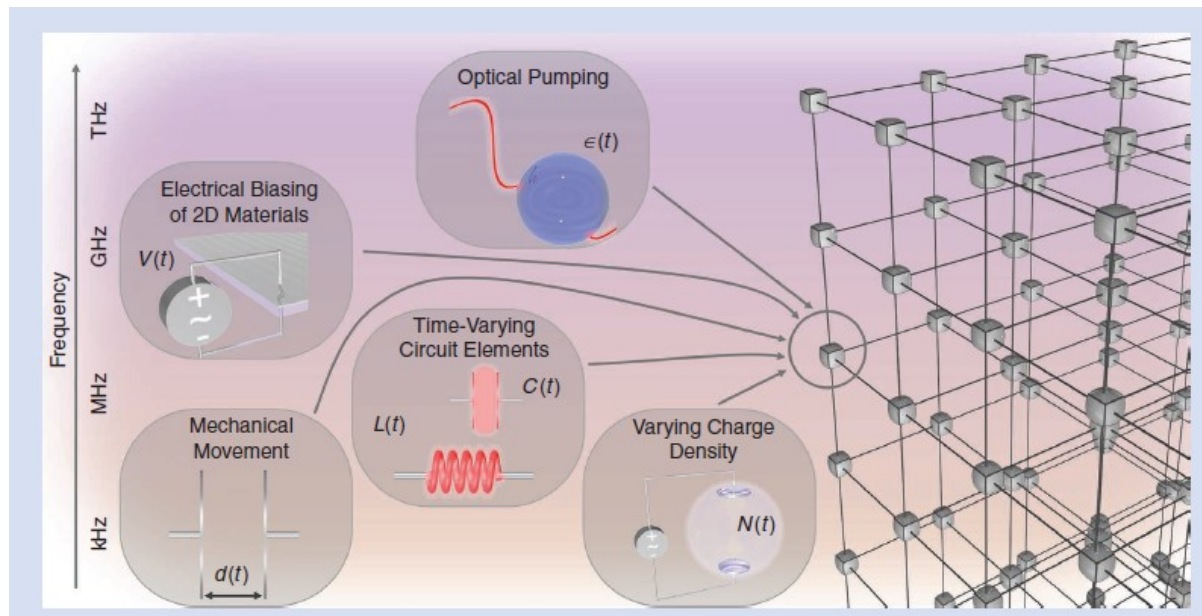

Fig. 1. A conceptual illustration of metamaterials with time-modulated meta-atoms.

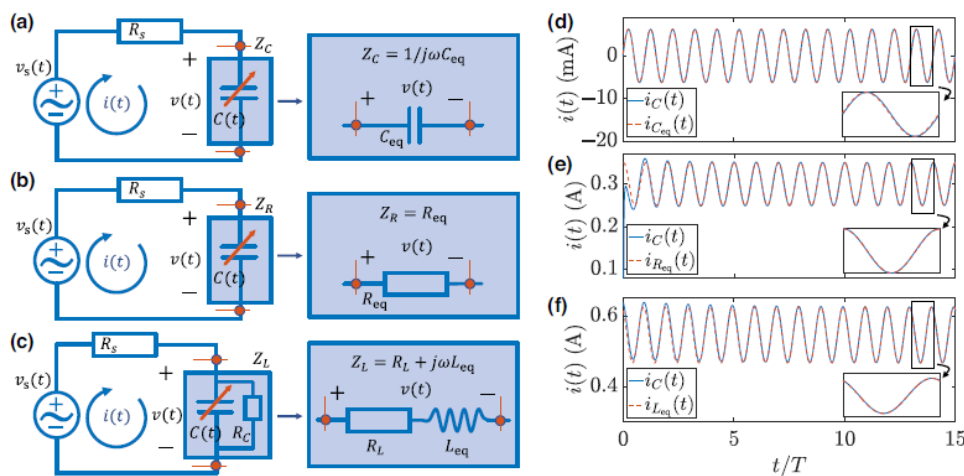

Fig. 2. (a) Electric circuit with a time-varying capacitance that mimics a capacitor with an arbitrary capacitance. (b) Electric circuit with a time-varying capacitance that mimics a resistor with an arbitrary value. (c) Electric circuit with a lossy time-varying capacitance that mimics a lossy inductor with an arbitrary value of inductance. (d),(e),(f) Currents flowing through circuits in (a),(b),(c).

As an exciting advance in the context of time-varying elements, AAST demonstrated various ways to emulate electromagnetic systems that can have arbitrary frequency dispersion and non-Hermitian, even nonlinear properties, including non-Foster responses through time-modulation. For instance, (Fig. 2) we showed that a proper modulation of a time-varying capacitor allows one

to mimic a static inductance, capacitance, or resistance having arbitrary values, both positive and negative. We discussed necessary modifications of given modulation functions that ensure the stability of the system. To demonstrate the applicability of the proposed method, we introduced and simulated an invisible sensor, i.e., a device that does not produce any scattering and is capable of sensing. In addition to that, we discussed the stability of the systems that are modulated externally. In parallel, we have been demonstrating virtual absorption, virtual gain, parity-time symmetry and loss compensation to overcome the limits of passive metamaterials by using complex frequency excitations. We believe that our progress in this area has been introducing a new paradigm to use time modulation to engineer dispersion, system responses for a wide range of applications.

A major breakthrough in our MURI project has been the modeling and realization of time-interfaces based on abrupt switching of the properties of a metamaterial. From the theory perspective, **AA** has analyzed rigorously the boundary conditions in various platforms that have been allowing us to experiment on time-interfaces, time-reflections and more. **AA,ST** have theoretically studied how surface-wave propagation along a reactive boundary is affected by temporal discontinuities of effective parameters characterizing the boundary. We showed that by switching the value of the surface reactance, the velocity of surface waves is fully controlled, and the power of reflected and transmitted surface waves can be amplified. We have used this response to demonstrate retro-reflection, polarization conversion and manipulation of the radiated frequencies, in an analogy to a spatial prism. All these intriguing phenomena enabled by temporal discontinuities of effective properties of reactive metasurfaces open interesting possibilities for the generation and control of surface waves. An interesting example is shown in Fig. 3.

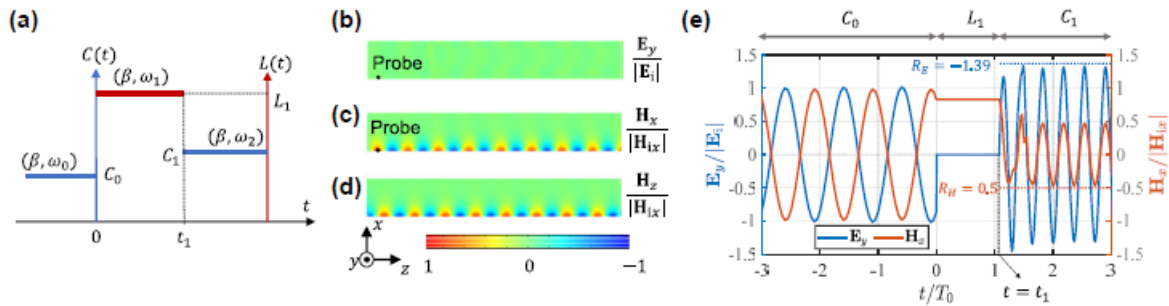

Fig. 3. Illustration of a phenomenon of frozen and melted surface wave.

ST,AA have extended time interfaces to arbitrary bianisotropic media, enabling a range of exciting opportunities. For instance, by introducing a temporal interface between isotropic chiral and dielectric media transforms a linearly polarized electromagnetic wave into forward right-handed and forward left-handed circularly polarized waves having different angular frequencies and the same phase velocities. This salient effect allows splitting light to two different polarization states with high efficiency (Fig. 4). This builds on previous work from **AA** on temporal Faraday rotation, but now demonstrated in a reciprocal setting.

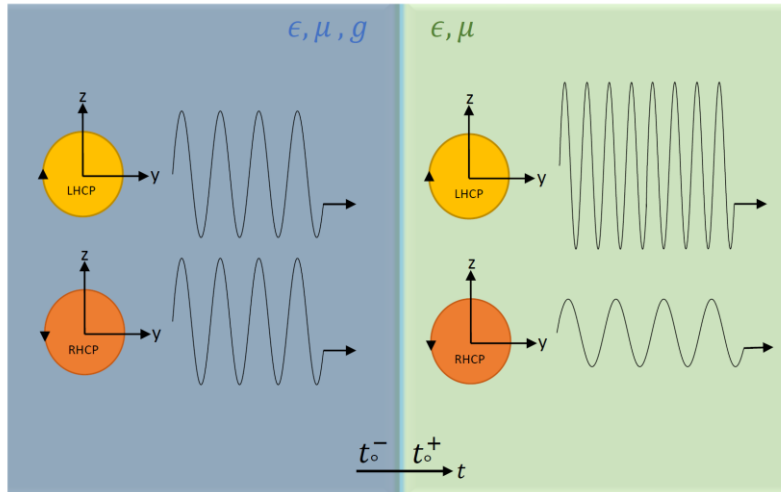

Fig. 4. An illustration of phenomena at a time interface in chiral media.

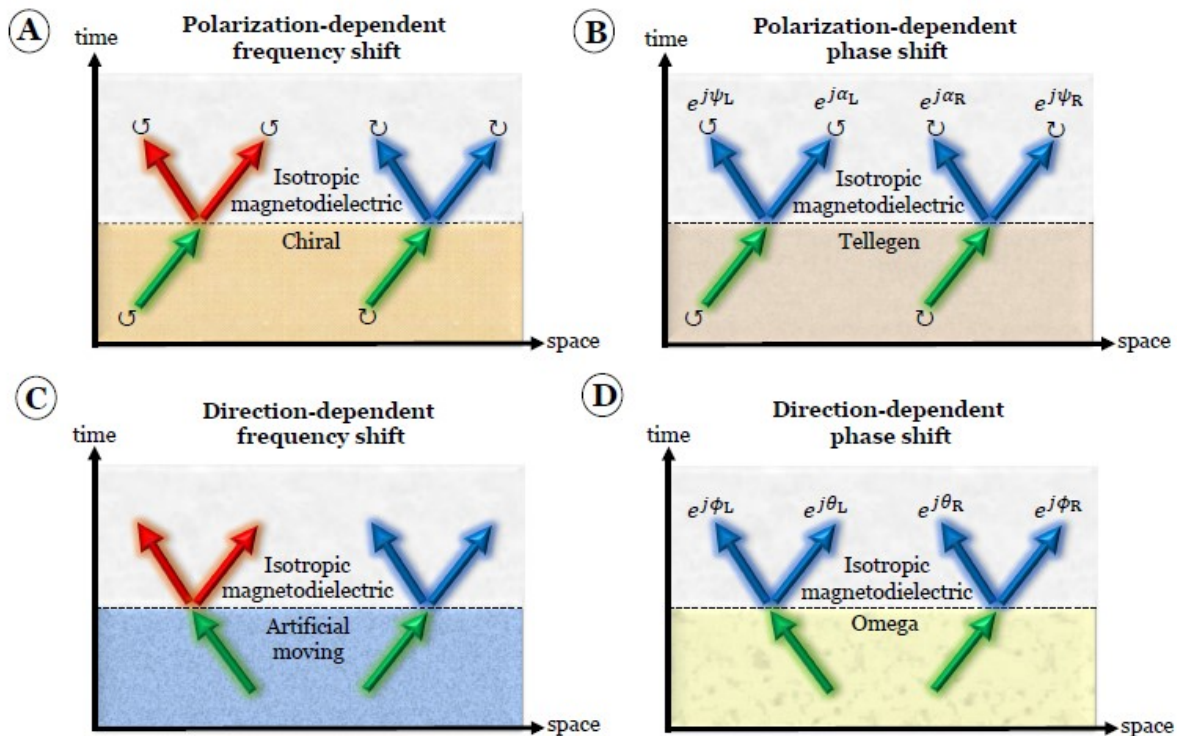

Fig. 5. An illustration of phenomena at time interfaces in all four fundamental classes of bianisotropic media.

The extension to general bianisotropic media is shown in Fig. 5: when the magnetoelectric coupling parameter suddenly jumps in time, it creates a time interface in bianisotropic media. We investigated scattering effects at such time interfaces, revealing new polarization- and direction-dependent phenomena. This work paves the road towards bianisotropic time metamaterials

(metasurfaces), and bianisotropic photonic time crystals, opening up interesting possibilities to control wave polarization and amplitude in reciprocal and nonreciprocal ways.

SF has continued his work on synthetic dimensions, applying it to time interfaces joining efforts with the rest of the MURI activities on this topic. Synthetic dimensions have garnered widespread interest for implementing high dimensional classical and quantum dynamics on low-dimensional geometries. Synthetic frequency dimensions, in particular, have been used to experimentally realize a plethora of bulk physics effects. However, in synthetic frequency dimension there has not been a demonstration of a boundary which is of paramount importance in topological physics due to the bulk-edge correspondence. We constructed boundaries in the frequency dimension of dynamically modulated ring resonators by strongly coupling an auxiliary ring. We explored various effects associated with such boundaries, including confinement of the spectrum of light, discretization of the band structure, and the interaction of boundaries with one-way chiral modes in a quantum Hall ladder, which exhibits topologically robust spectral transport. Our demonstration of sharp boundaries fundamentally expands the capability of exploring topological physics, and has applications in classical and quantum information processing in synthetic frequency dimensions (Fig. 6).

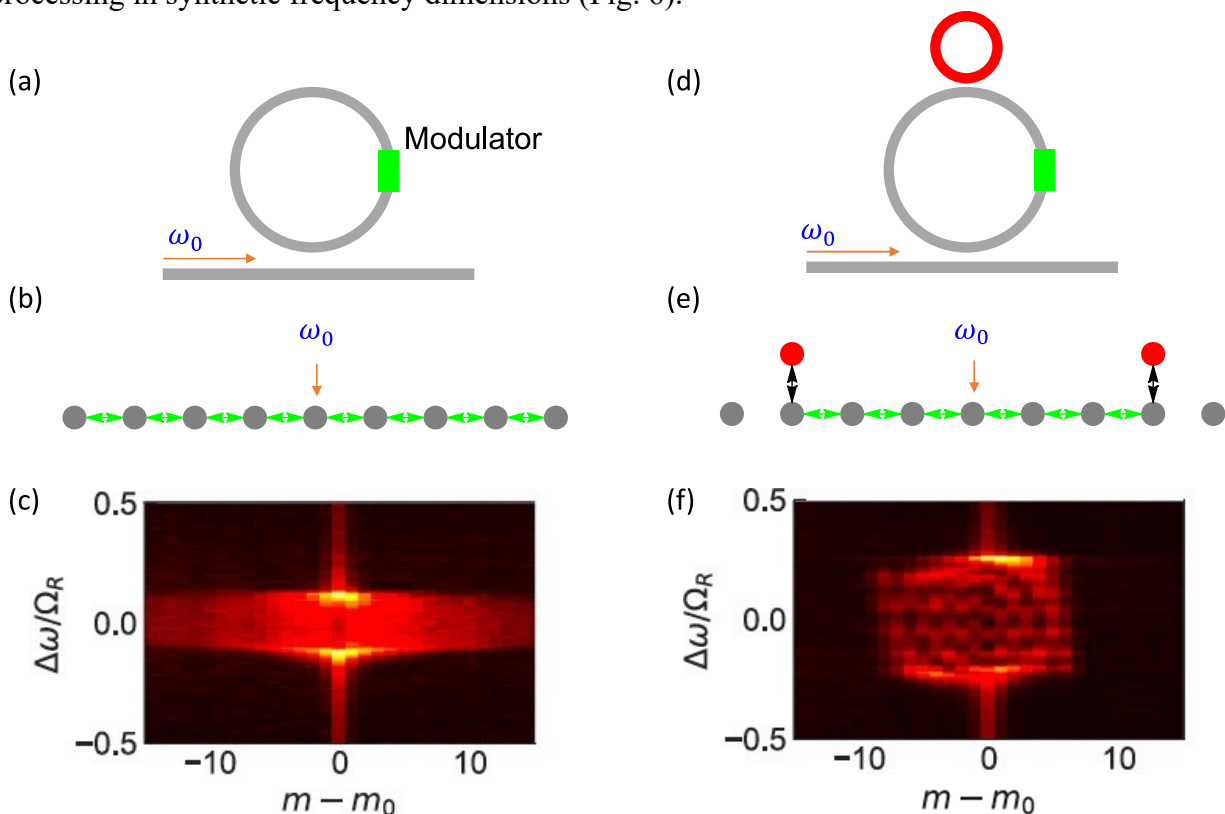

Fig. 6. (a) A modulated ring resonator coupling to a waveguide. (b) The structure in (a) is described by a tight-binding model along the frequency dimension without boundary. (c) Experimental results showing the excitation of many modes along the frequency dimension as denoted by m . (d) A modulated ring resonator coupling to a waveguide with an additional ring introduced. (e) The structure in (d) is described by a tight-binding model with a boundary. (f) Experimental results showing the excitation of only those modes within the boundary introduced along the synthetic frequency dimension.

Periodic boundary conditions have become indispensable in the design of spatially periodic structures such as phased array antennas, photonic crystals and metamaterials/metasurfaces. **AG,AA** introduced analogous periodic boundary conditions for traveling-wave modulated structures that are periodic in both space and time. **AG** introduced a powerful interpath relation, which dramatically decreases the computational resources needed to analyze as well as optimize space-time periodic structures. Based on this finding, we examined electromagnetic structures with a spatially-discrete traveling-wave modulation (SDTWM). In these structures, a staggered time modulation is applied to discrete points in adjacent unit cells of a space-time periodic structure (see Fig. 7). In contrast to continuous spatial modulation, each temporal frequency harmonic is associated with an infinite set of spatial harmonics. These additional spatial harmonics can be used to alter the space-time distribution of a wave in ways that cannot be achieved in the continuum limit.

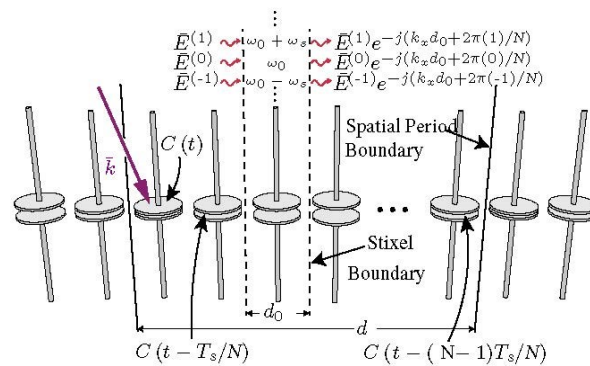

Fig. 7. Illustration of an infinite array of capacitively loaded dipoles modulated in the form of a discrete traveling-wave. The interpath relation is shown relating the fields on the left- and right-hand side of a stixel.

In SDTWM structures, each spatial modulation period consists of a collection of unit cells (see Fig. 8). These unit cells will be referred to as stixels: space-time pixels. They are the smallest indivisible element of a SDTWM structure. Analogous to a continuous traveling-wave modulation, the modulation signal applied to stixel n is given by $M(t, n) = f(t - nd_0T_s/d)$, where d_0 is the dimension of a single stixel, and d is the spatial period. If there are exactly N stixels in a spatial modulation period, then $d = Nd_0$, and $M(t, n) = f(t - nT_s/N)$. Such a modulation is reminiscent of the modulation applied to N-path circuit networks.

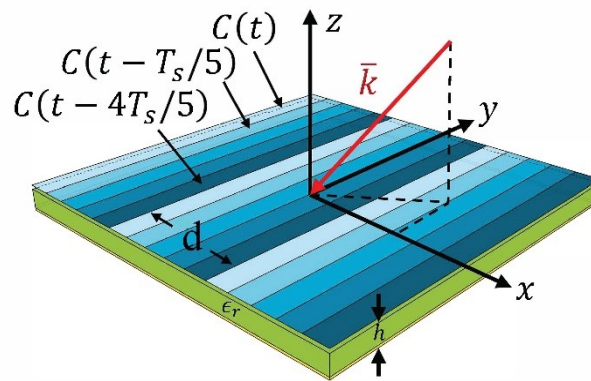

Fig. 8. Illustration of a spatially-discrete traveling-wave modulated metasurface.

The boundary condition governing the fields across each stixel of a SDTWM structure is referred to as the interpath relation, due to its similarity to a relation derived for N-path circuit network. The interpath relation can be expressed either in the time domain or frequency domain. Consider a general SDTWM structure, such as the one shown in Fig. 8, with SDTWM in the x direction. We showed that the fields supported by a SDTWM structure under a monochromatic excitation (in this case, an incident plane wave at frequency f_0 with a tangential wavenumber k_x), must satisfy the relation

$$\bar{\mathcal{E}}(x, y, z, t) = e^{j(\omega_0 T_s/N - k_x d/N)} \bar{\mathcal{E}}(x - d/N, y, z, t - T_s/N). \quad (1)$$

This is the time domain form of the interpath relation. Since the system is linear and periodically time varying (LPTV), the field throughout space can be expanded into temporal-frequency harmonics corresponding to frequencies $\omega_0 + q\omega_s$. Substituting this Fourier expansion into the time-domain interpath relation (1) yields a new relation that the field supported by a SDTWM structure at frequency $f_0 + qf_s$ must satisfy

$$\begin{aligned} \bar{E}_q(x, y, z) &= e^{-j(k_x d/N + q\omega_s t_0)} \bar{E}_q(x - d/N, y, z) \\ &= e^{-j(k_x d/N + 2\pi q/N)} \bar{E}_q(x - d/N, y, z), \end{aligned} \quad (2)$$

where $t_0 = T_s/N$. This expression is known as the frequency domain interpath relation for SDTWM structures. It can be interpreted as a frequency (temporal harmonic) dependent Bloch boundary condition for a stixel. In fact, the general field solution of a SDTWM structure is of the following form,

$$\bar{E}_q(x, y, z) = \bar{V}_q(x) e^{-j(k_x + \frac{2\pi q}{a})x}. \quad (3)$$

$\bar{V}_q(x)$ is a function that is periodic with stixel period ($d_0 = d/N$) and has spatial harmonics corresponding to wavenumbers $r \frac{2\pi}{d_0} = r \frac{2\pi N}{d} = rN\beta_s$ that models the microstructure of the field within a stixel. As a result, the interpath relation tells us that a frequency harmonic $\omega_0 + q\omega_s$ in a SDTWM structure is associated with an infinite number of spatial harmonics with tangential wavenumbers given by $k_x + q\beta_s + rN\beta_s$.

The interpath relation has significant implications for the numerical simulation of SDTWM structures. Namely, that the fields within a single stixel are sufficient to determine those throughout the entire structure. Using these properties, we have written efficient solvers capable of computing the fields throughout space while only placing unknowns within a single stixel. A patent was filed as a result of the MURI work, where we describe how to efficiently simulate SDTWM structures. Traveling-wave modulated structures can be one dimensional (1D), two dimensional (2D) or three dimensional (3D). The spatial period of a 3D traveling-wave modulated structure that is spatially discretized can consist of N , M and P stixels in the three orthogonal directions. Therefore, using the interpath relation reduces the simulation domain by a factor of $N \times M \times P$.

Traveling-wave modulation (TWM) has been used extensively in recent years to achieve electromagnetic functionalities such as frequency-conversion, beam-steering, non-reciprocity, and amplification. TWM is often implemented by applying a staggered modulation to a spatially-discrete array of tunable unit cells, as shown in **Error! Reference source not found.**9. As previously noted, this form of modulation is referred to as spatially-discrete traveling-wave modulation (SDTWM).

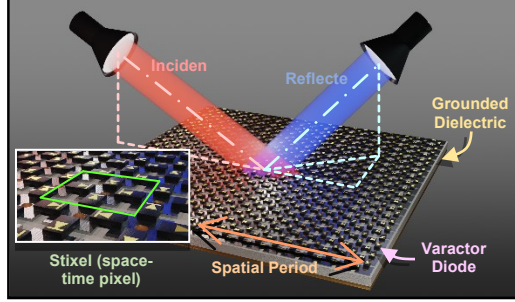

Fig. 9. Spatially-discrete traveling-wave modulated metasurface consisting of a varactor-diode loaded capacitive sheet placed above a grounded dielectric substrate.

Prior to our work, simulating space-time modulated media with numerical solvers required modeling an entire spatial period of constituent staggered, time-varying unit cells: stixels. The computational cost of these earlier numerical techniques can quickly become prohibitive, which has led researchers to often ignore the effects of spatial discretization in design. However, disregarding spatial discretization reduces accuracy and eliminates the possibility of electromagnetic functions, such as subharmonic mixing, which cannot be achieved using spatially-continuous traveling-wave modulation. Utilizing the interpath relation, we have developed efficient numerical solvers for simulating SDTWM structures. Specifically, two method-of-moments (MoM) solvers were developed for computing the field scattered by a SDTWM capacitive sheet placed on top of a grounded dielectric substrate (see Fig. 10). Both spectral- and spatial-domain solvers were developed which invoke the interpath relation for computing the fields scattered by such metasurfaces. While alternative methods have been reported for analyzing traveling-wave (and more general space-time modulated) structures, they do not invoke the interpath relation to reduce the problem size. Next, representative metasurface examples computed using the spatial domain MoM solver are described.

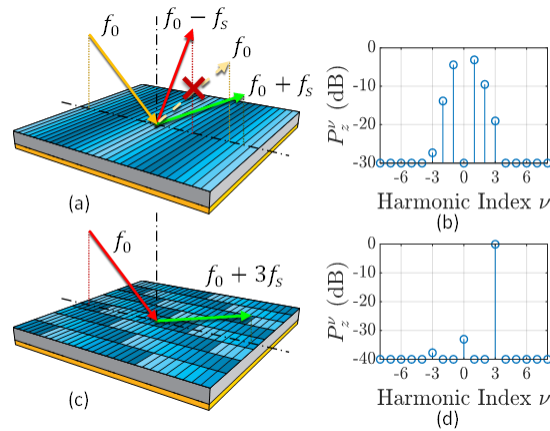

Fig. 10. Two modulation cases for a SDTWM capacitive sheet above a grounded dielectric. In both cases, the scattered power radiated from the metasurface at each frequency $f_0 + \nu f_s$ is reported. In (a), the metasurface is configured to eliminate the fundamental harmonic from the reflected field. The scattered power for this case is depicted in (b). In (c), the metasurface is configured to achieve simultaneous subharmonic mixing and beam-steering. The scattered power for this case is depicted in (d).

A SDTWM metasurface is shown in Fig. 10(a) which suppresses reflection at the fundamental frequency (f_0), as demonstrated in Fig. 10(b). If the spatial modulation period is small (subwavelength in size), then the interpath relation shows that certain frequencies will be bound to the near-field of the metasurface. This can be exploited to couple an incident signal to a higher-order frequency harmonic reflected in the specular direction. By maintaining an electrically large spatial period along one dimension and a subwavelength spatial period along the other, beam-steering and subharmonic mixing can both be achieved simultaneously. An example of this case is depicted in Fig. 10(c) and (d).

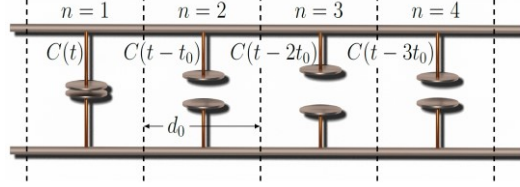

Fig. 11. Spatially-discrete traveling-wave modulated (SDTWM) electrical network consisting of a transmission line loaded with SDTWM capacitors.

We have also used the interpath relation to formulate a generalized eigenvalue problem for SDTWM electromagnetic structures and electrical networks and to analytically and numerically characterize SDTWM electrical networks. For instance, the Bloch impedance has been generalized from a scalar in spatially periodic networks to a vector in SDTWM electrical networks. The generalized eigenvalue problem for SDTWM structures is obtained by applying the interpath relation across a single stixel. Consider an SDTWM structure like the one in Fig. 5. Since the structure is linear and periodically time-varying (LPTV), the voltage and current at the input of stixel n can be expanded into frequency harmonics as a Fourier series, $v_n(t) = \sum_{q=-\infty}^{\infty} V_{n,l} e^{j(\omega_0 + q\omega_s)t}$, where ω_0 is the frequency of the excitation, and ω_s is the modulation frequency. The voltage and current frequency harmonics within stixels n and $n + 1$ are linked through the interpath relation as

$$V_{n+1,q} = V_{n,l} e^{-j(\kappa d_0 + q\omega_s t_0)}, \quad I_{n+1,q} = I_{n,q} e^{-j(\kappa d_0 + q\omega_s t_0)} \quad (4)$$

where t_0 is the delay in the time-variation of neighboring stixels. The voltage and current frequency harmonics at the input and output of stixel n can also be related through a frequency harmonic transmission matrix (or ABCD matrix), $\bar{\bar{T}}_n$, such that $\begin{bmatrix} \bar{V}_n \\ \bar{I}_n \end{bmatrix} = \bar{\bar{T}}_n \begin{bmatrix} \bar{V}_{n+1} \\ \bar{I}_{n+1} \end{bmatrix}$, where the elements of \bar{V}_n and \bar{I}_n are $V_{n,q}$ and $I_{n,q}$ respectively. This yields the generalized eigenvalue problem for SDTWM networks

$$e^{j\kappa d_0} \begin{bmatrix} \bar{V}_n \\ \bar{I}_n \end{bmatrix} = \bar{\bar{T}}_n \begin{bmatrix} \bar{D} & 0 \\ 0 & \bar{D} \end{bmatrix} \begin{bmatrix} \bar{V}_n \\ \bar{I}_n \end{bmatrix}, \quad \bar{D}[q, q'] \equiv \delta_{q-q'} e^{-jq\omega_s t_0} \quad (5)$$

The generalized eigenvalue problem above can be used to compute the dispersion relation of a given structure, as well as determine the response of a finite cascade of stixels. In contrast to conventional space-time electromagnetic field solvers, which require an entire spatial period to be modeled, only a single period needs to be considered in our case. We have used the eigenvalue problem in (5) to characterize several SDTWM structures that exhibit non-LTI phenomena: frequency conversion, non-reciprocity and parametric amplification. We have shown that well-known effects in nonlinear optics such as parametric amplification and parametric upconversion can be modeled using SDTWM structures.

We have also applied the interpath relation to an infinite array of driven SDTWM unit cells with phased sources to derive the Green’s functions of SDTWM structures. The Green’s function derivation is a generalization of the analytical array scanning method used to formulate boundary-value problems involving the single source excitation of an infinite spatially periodic structure. It has also been applied to calculate the response of rings of SDTWM networks and to design circulators and time-varying electrically-small antennas.

In addition to constructing custom MoM solvers to simulate SDTWM metasurfaces (that exploit the interpath relation to shrink the computational domain down to one stixel) **AG** has also devised a procedure for simulating SDTWM structures using commercial solvers. The co-simulation procedure still retains the same computational advantage. As noted, planar SDTWM structures have been simulated using custom codes, which typically only consider simplified (homogenized) geometries. In contrast, the co-simulation method, using a commercial full-wave solver and a harmonic balance circuit solver, allows for the simulation of structures possessing stixels with fine features. It consists of two steps. First, a single stixel of the planar SDTWM structure is simulated using a driven, periodic solver of a commercial electromagnetic field simulator (e.g. Floquet ports and periodic boundary conditions in Ansys HFSS) at each relevant frequency harmonic. Lumped ports are placed at the locations of time-varying components, and a Floquet port(s) terminates the stixel domain in the direction normal to the structure (at the stixel top and bottom walls). The interpath relation is used to set the phase boundary conditions that terminate the stixel in the transverse directions (at the stixel side walls). The simulation results of the stixel are then imported as a multiport scattering matrix file into a commercial, harmonic balance circuit solver (e.g., Keysight ADS Momentum). In the circuit solver, time-varying components are attached to the lumped ports in order to simulate the SDTWM structure. In summary, this simulation test bench leverages two separate commercial solvers (a frequency domain electromagnetic solver and a harmonic balance circuit solver) to simulate SDTWM structures.

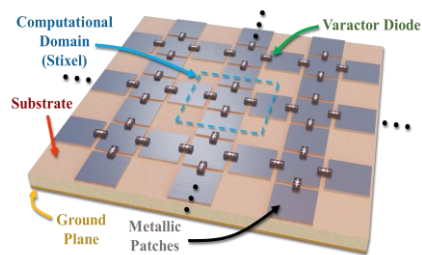

Fig. 12. Illustration of a reflective, SDTWM metasurface.

The co-simulation procedure was verified by examining the reflective, space-time metasurface shown in Fig. 12. It consists of metallic patches interconnected by varactor diodes over a grounded dielectric substrate, and it allows for SDTWM along the two orthogonal directions tangential to the metasurface. The structure acts as a reflective phase modulator that can be used to realize space-time reflected phase profiles. Applying a sawtooth reflection phase profile that travels across the metasurface shifts both the spatial and temporal spectrum of the reflected wave, providing beam steering and frequency conversion. An example is chosen where the modulation frequency is 1 MHz. The delay is selected such that the beam is steered from an incidence angle $(\theta_i, \phi_i) = (30^\circ, 0^\circ)$ to a reflected angle $(\theta_r, \phi_r) = (45^\circ, 30^\circ)$. The co-simulation procedure for this structure is compared to the MoM procedure for a capacitive sheet placed over

a grounded dielectric, and close agreement is shown. The spectrum of the scattered power computed by both solvers is shown in Fig. 13. It can be seen that the wave is upconverted to the first frequency harmonic ($\omega_0 + \omega_s$) with a conversion efficiency of -1 dB.

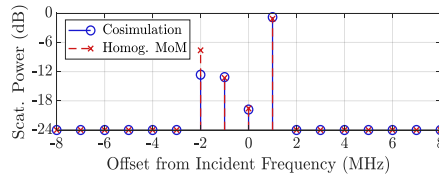

Fig. 13. Scattered power spectrum from the metasurface shown in Fig. 12, computed by the co-simulation procedure and the custom Method of Moments solver.

Electrically-small scatterers may be modelled effectively using equivalent circuit models, as previously explored in our MURI. **AG** has extended these circuit models to electrically-small scatterers with time-varying parameters, which leads to circuit models with time-varying lumped components. This analysis was also extended beyond isolated time-varying resonators to systems of coupled time-varying resonators. By applying this method to small, resonant spheres, circuit models were developed from which predictions of parametric processes such as parametric upconversion and negative-resistance amplification could be made. To develop the circuit models for the time-varying scatterers, a circuit is found such that when an ideal electric or magnetic Hertzian dipole is loaded with the circuit, the polarizability of the loaded dipole is equivalent to that of the physical scatterer. For spherical scatterers, there is additional physical meaning to the parameters of the equivalent circuit. The structure of the equivalent circuit itself is determined by Kirchhoff's current law (KCL), which is isomorphic to the normal boundary condition on the surface of the sphere. This makes physical sense since the normal boundary condition enforces the conservation of displacement and conduction currents on the boundary, just as KCL enforces conservation of charge at a node. Similarly, the voltage dropped across the equivalent circuit physically corresponds to the open-circuit voltage that the local field induces at the terminals of the ideal dipole. In order to correctly model the small scatterer, a modification is made to the usual Rayleigh scattering analysis which accounts for the radiation reaction field. The inclusion of this radiation reaction field leads to a radiation resistance within the equivalent circuit model, and the power that is dissipated within this resistor exactly corresponds to the power scattered from the system.

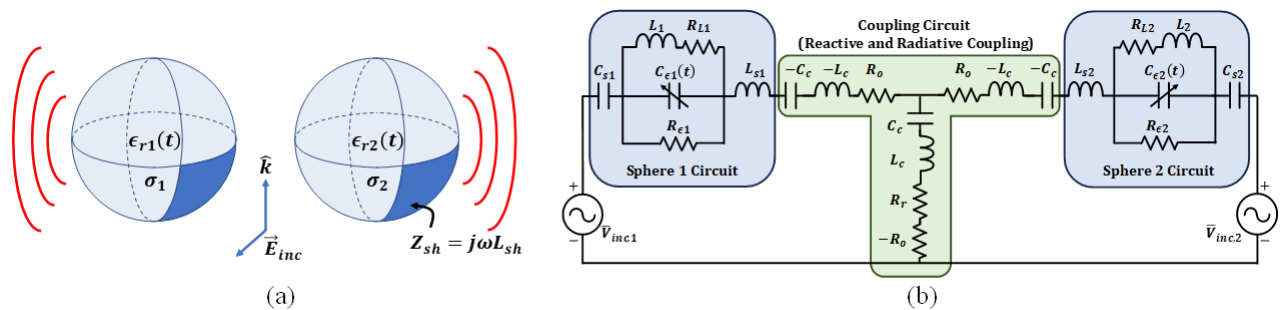

Fig. 14. (a) Coupled electrically-small spheres. Each sphere consists of an inductive sheet impedance enclosing a time-varying dielectric. (b) Equivalent circuit model for two coupled, time-varying spheres. C_c , L_c , R_r , and R_o represent coupling between the resonators, the time-varying capacitors represent time-varying permittivities, and the resistances R_{L1} , R_{L2} , $R_{\epsilon 1}$, and $R_{\epsilon 2}$ represent losses in the inductive sheet and in the dielectric.

When modelling coupled spherical scatterers (see Fig. 14(a)), the coupled dipole approximation yields a coupled circuit model, which is shown in 14(b). The circuit has two fundamental resonances: one corresponds to the case where the scatterers have in-phase polarization currents (even mode), whereas the other corresponds to the case where the scatterers have anti-phase (odd mode). These two modes can be used as the resonant tanks to achieve parametric amplification with the time-varying spheres, where the gain can be predicted with classic circuit analysis techniques for parametric amplifiers using the equivalent circuit model. **AG** also refined their equivalent circuit models for time-varying, electrically-small radiators, which can be used to model parametric amplification from a system of two time-varying coupled resonators. By developing a semi-analytic formulation for the coupled sphere problem based on the Mie solution, the validity of this circuit model was verified.

The work on coupled, time-varying canonical scatterers has been extended to more general coupled time-varying structures, and in particular to coupled antennas. The insights gained from the circuit models of coupled electrically-small spheres, has allowed **AA,AG** to develop an approach to enhancing the efficiency-bandwidth product of electrically-small antennas (ESAs). This has led to a successful transition to the IARPA EQuAL-P (Effective Quantitative Antenna Limits for Performance) Program. The objective of the I-ARPA work is to use time variations to enhance the bandwidth-efficiency product of ESAs with a goal of 10dB improvement compared to an equivalent LTI ESA.

Thrust 2: Radio-frequency guided waves and radiation

Our MURI team has translated many of our theoretical advances into proof-of-concept implementations of time-varying metamaterials demonstrating enhanced responses and functionalities. In this Section, we highlight a few exciting discoveries in the radio-frequency domain. As a first example, we used slow time modulation of resistive elements to engineer the bandwidth of small antennas. The temporal modulation of resistance induces a virtual impedance that is fully controlled by the modulation parameters, based on the concept of virtual reactance introduced in this program by **AA**. **ST** showed how the virtual impedance can be used to optimize the frequency response of a resonant circuit, leading to enhanced matching at multiple frequencies simultaneously. We experimentally verified the proposed technique, demonstrating enhancement of radiation of a broadband modulated signal radiated by a small antenna, as shown in Fig. 15.

As one of the major breakthroughs of our MURI, we have recently demonstrated time reflections and efficient frequency translation based on time switching, as well as photonic collisions for efficient energy exchanges, establishing a new paradigm for wave control. These phenomena arise at time interfaces, which consist of a sudden change in the properties of the material where the waves are traveling, as we discussed in the previous Section. To be effective, this change must be much faster than the temporal dynamics of the involved signals. We realized this phenomenon in a radio-frequency loaded transmission-line metamaterial, demonstrating all the major features of time-interfaces: time-reflections, broadband phase conjugation and frequency translations. In addition, we demonstrated that by carefully choosing when the time-interface occurs while two interfering pulses spatially overlap, we showed efficient control of the energy and frequency in both waves after the collision. The choice of timing at which the time interface is triggered determines the phase of spatial overlap between the two waves: as shown in the top row of Fig. 15, the two waves (in blue and red) can either align peaks with peaks (in-phase, panel

c), with valleys (out-of-phase, panel g), or in between (panel e). After a time interface (lightning symbol), the total electromagnetic momentum is always conserved, but the energy can be either suppressed, e.g., completely erasing one of the two waves, (panel d), increased equally in both waves (panel h), or any other outcome in between (panel f). These dynamics establish the wave analogue to how particles collide mechanically, as shown in the bottom row of Fig. 15. Crucially, the wave collisions that researchers demonstrated allow precise control over the energy content of short electromagnetic pulses, no matter their frequency content. Hence, wave pulses, which would not normally interact, can be made to effectively collide as if they were bouncing off each other, and their relative phase at the time interface is a knob that enables one to choose between gaining, conserving, or losing energy in this process.

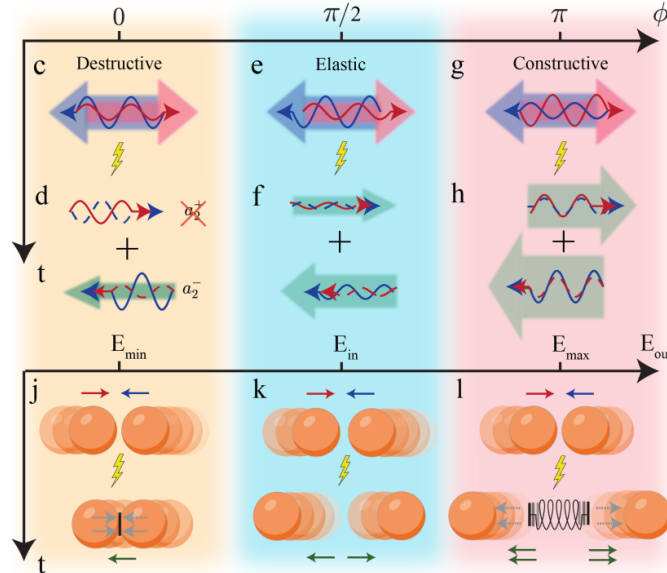

Fig. 15. As a function of the relative phase between two oppositely travelling electromagnetic pulses, a time-interface enables destructive collisions (left), e.g., annihilating entirely one of the two pulses, elastic collisions (center), or constructive collision (right), respectively reducing, conserving, or increasing the total energy in the system, while preserving the net electromagnetic flux. This mimics mechanical collisions, which can reduce, conserve or increase the total kinetic energy of the two colliding objects based on the nature of the internal forces between them.

In parallel, **ST,SF** extended the concept of photonic time crystals to metasurfaces. We demonstrated that time-varying metasurfaces not only preserve key physical properties of volumetric photonic time crystals despite their simpler topology but also host common momentum bandgaps shared by both surface and free-space electromagnetic waves. On the basis of a microwave metasurface design, we experimentally confirmed the exponential wave amplification inside a momentum bandgap and the possibility to probe bandgap physics by external (free-space) excitations. The proposed metasurface serves as a straightforward material platform for realizing emerging photonic space-time crystals and as a realistic system for the amplification of surface-wave signals in future wireless communications (Fig. 16-17). In parallel, **AA** has been demonstrating time crystal concepts in the transmission-line metamaterial explored for time-interfaces, and explored the extension of these phenomena to higher frequencies through the use of optical pumping and of CMOS-based technology.

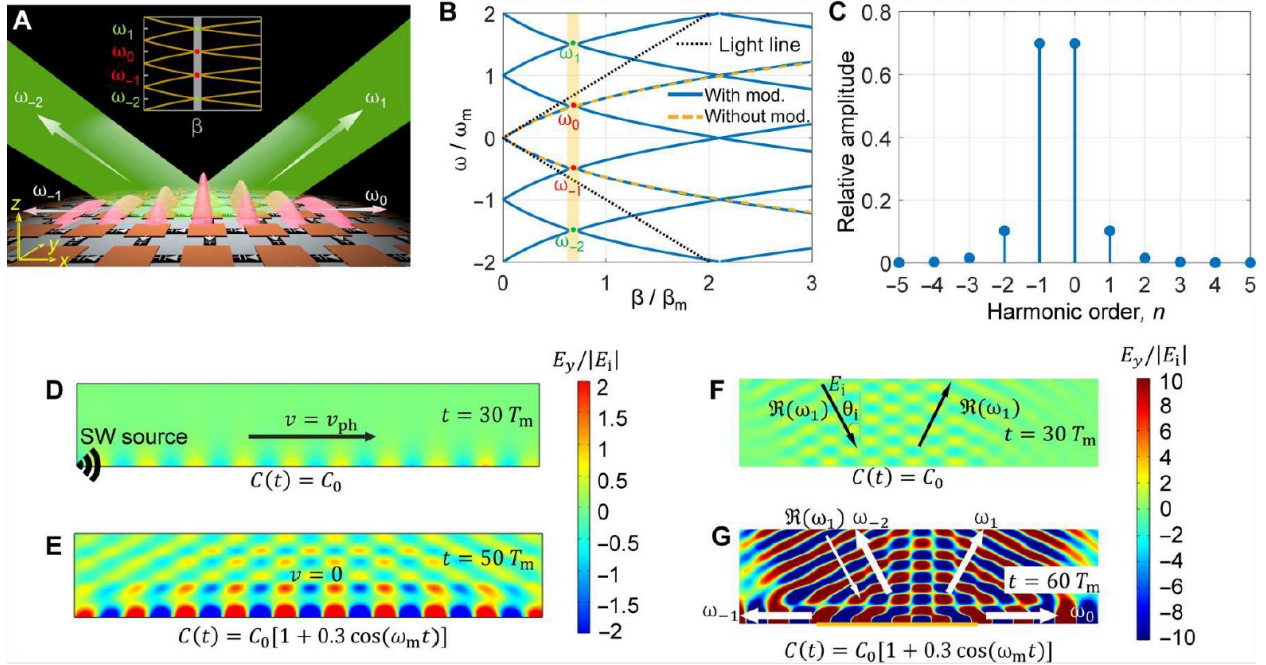

Fig. 16. (a) Conceptual design of a metasurface working as a photonic time crystal. (b) The band structure of the photonic time crystal. (c) Spectral composition of the electric field for the mode in the momentum band gap. (d) An example of the generation of slow guided space-time wave packets with $v_g = 1 \times 10^{-5} c$. (d-g) Electric field distributions at various times during the operation of the time crystal.

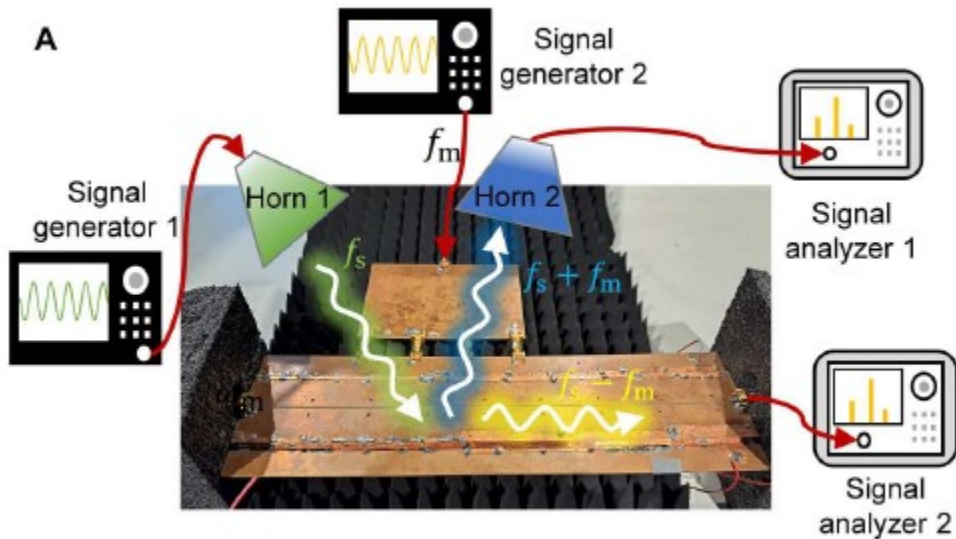

Fig. 17. Experimental set-up for studying free-space excitation of metasurface time-crystals.

AG developed in this program some of the earliest experimental demonstrations and test platforms of time and space-time modulated metasurfaces. A dual-polarized, space-time modulated metasurface was developed and measured at X-band frequencies. Each column of subwavelength unit cells comprising the metasurface can be independently modulated, to provide

a tunable reflection phase over a range of 330° . The modulation waveform applied to adjacent columns can be staggered in time to realize SDTWM of the metasurface. A unit cell of the metasurface is shown in Fig. 18. Varactor diodes are integrated onto the metasurface to act as tunable capacitances for two orthogonal polarizations. Fig. 19 depicts the fabricated metasurface.

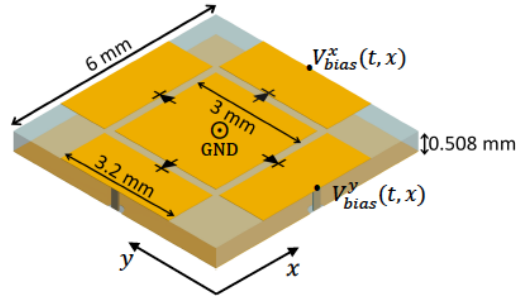

Fig. 18. Unit cell of a metasurface test platform: a dual-polarized, SDTWM metasurface.

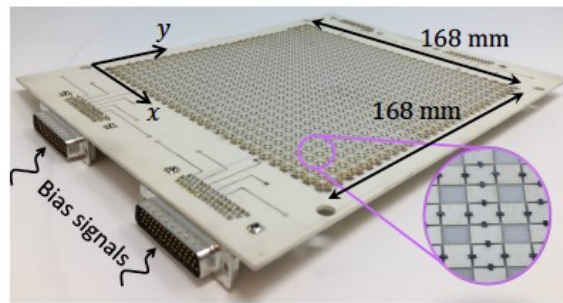

Fig. 19. Photograph of the test platform: SDTWM metasurface whose unit cell is shown in Fig. 18.

The SDTWM experimental platform was homogenized and theoretically analyzed. Its measured performance, carried out using the setup presented in Fig. 20, was shown to closely agree with theoretical predictions. Subharmonic mixing at specular reflection angles was theoretically predicted and experimentally demonstrated for electrically small modulation periods. For electrically-large modulation periods of the metasurface, simultaneous frequency translation and angular deflection was also experimentally demonstrated. Finally, for spatial modulation periods that are wavelength-scale, simultaneous subharmonic frequency translation and angular deflection was demonstrated. For certain incident angles, retroreflective subharmonic frequency translation was also shown to be possible.

In addition to the space-time metasurface described above (see Fig. 18 and Fig. 19), a time-modulated transparent (reflectionless) metasurface was also developed under this program. The metasurface frequency-shifts incident waves upon transmission. With a simple biasing architecture, the metasurface provides electrically-tunable transmission phase that covers 360° . A sawtooth waveform was used to modulate the metasurface, allowing Doppler-like frequency translation: Doppler spoofing, as proposed theoretically by AA,AG in the early stages of this program.

AG also explored the frequency harmonic suppressing property of SDTWM structures to devise a novel antenna (see Fig. 20), which performs subharmonic frequency mixing and radiates

simultaneously. The design converts an input signal at ω_0 to a radiated output signal at $\omega_0 + 3\omega_s$. The subharmonic mixing antenna consists of a monopole connected to three SDTWM capacitors ($N = 3$). The monopole's length is roughly $\lambda/4$ at the intended output frequency of $\omega_0 + 3\omega_s$. The phase induced by the modulation, $2\pi l/N$, (where l is an integer) prevents frequencies $\omega_0 + \omega_s$ and $\omega_0 + 2\omega_s$ from radiating, while a poor impedance match suppresses fundamental frequency ω_0 from radiating. In contrast, frequency $\omega_0 + 3\omega_s$ radiates since the upconverted currents in the stixels are in-phase and the monopole is resonant at this frequency. The fabricated prototype up-converts an input signal at 0.95 GHz to an output signal at 2.45 GHz with a modulation frequency of 0.5 GHz.

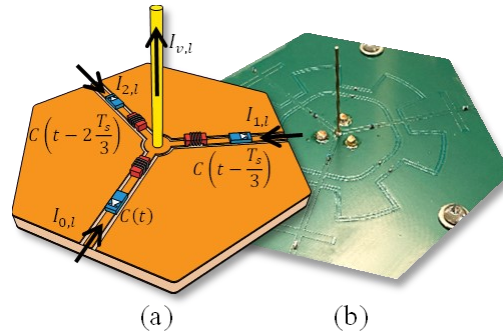

Fig. 20. (a) Idealized and (b) fabricated prototype of the SDTWM antenna design for subharmonic mixing.

As a different set of devices, we have invested significant efforts in our explorations to realize magnet-free non-reciprocal devices based on time-modulation. By integrating aluminum nitride (AlN) piezoelectric actuators on top of Si_3N_4 photonic devices, we demonstrated the first acousto-optic modulation (AOM) of Si_3N_4 microring resonators using HBARs. Sub-micrometer wavelength acoustic waves are excited by macroscopic actuators, which transmit vertically into the substrate and perpendicular to optical paths. Moving further, we concentrated our efforts on enhancing the modulation efficiency. Optomechanical single-photon coupling strength g_0 is inversely proportional to the square root of the mode volume of the mechanical and optical modes. The efficiency is proportional to the square of g_0 , thus making efficiency proportional to the inverse of the mechanical mode volume. Also, the electromechanical coupling efficiency increases by shrinking the mode volume due to better impedance match. Hence, to enhance the modulation efficiency, we partially release the optical microring from its silicon substrate, thereby reducing the volume of the HBAR modes to a small region where it interacts with the optical field. This improves the energy transfer from the microwave control to the optical signal to the point that modes residing in the silicon oxide cladding can now be detected optically.

Figure 21d shows the fabricated device's false-colored, top-view scanning electron microscope (SEM) image with three AlN actuators integrated on a released Si_3N_4 microring resonator. The thickness of Al / AlN / Mo is 100 / 1000 / 100 nm, respectively. The center hole is opened for Si-isotropic dry etching using the SF_6 Bosch process, to partially remove the Si substrate and to suspend the 5.4- μm -thick SiO_2 cladding. Figure 21b shows the simulated stress distribution of one HBAR mode within the SiO_2 layer using Finite Element Method (FEM). It can be seen that the HBAR mode is uniformly distributed under the AlN actuator and tightly confined in the SiO_2 membrane, allowing direct modulation of the optical mode propagating along the waveguide through photoelastic and moving boundary effects.

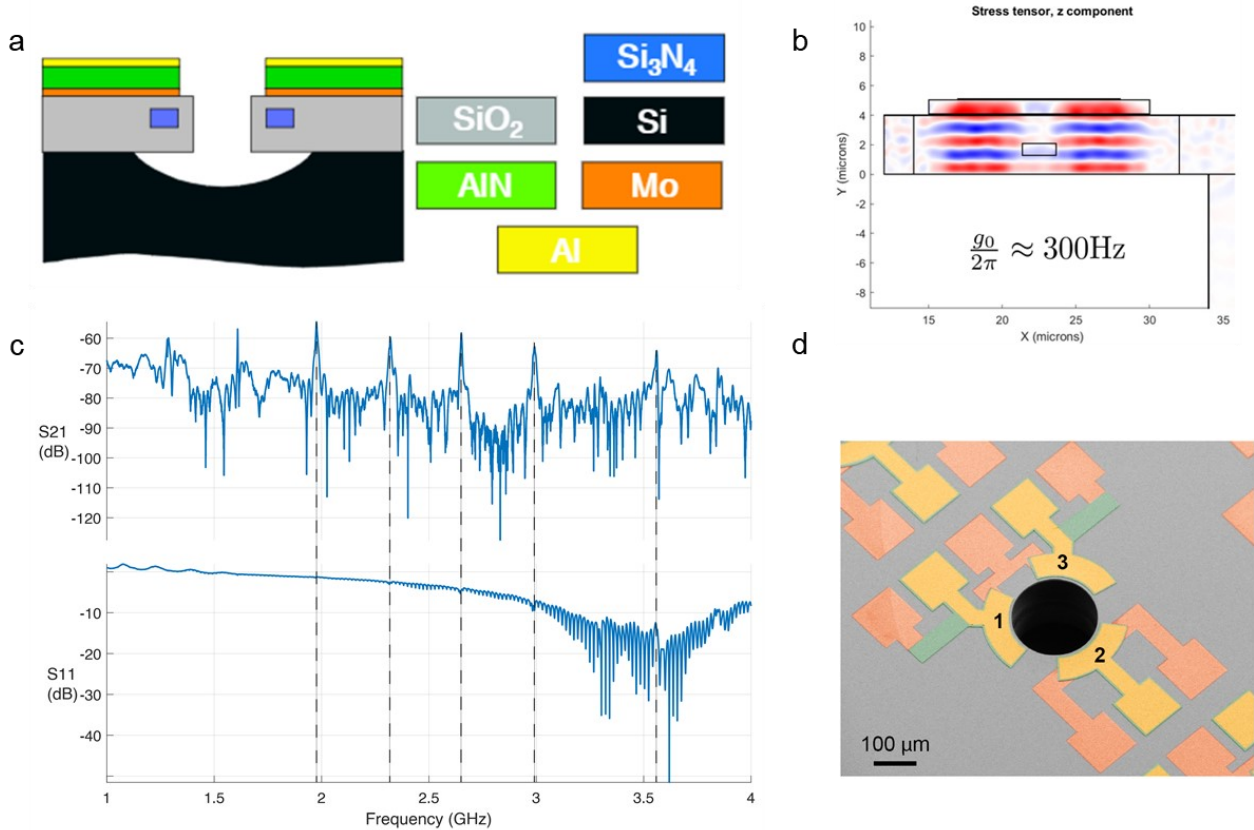

Fig. 21. Characterization of mechanical properties of the integrated MEMS-photonic device. (a) Schematic showing suspended SiO₂ membrane containing the Si₃N₄ microring resonator, to enhance the optomechanical coupling. The key technique used here is the Si isotropic dry etch using SF₆ Bosch process (b) FEM numerical simulations of the vertical stress σ_z distribution of a typical HBAR mode at 3 GHz. (c) Optomechanical S₂₁ response of an actuator and its microwave reflection S₁₁. (d) False-colored top-view SEM image of the fabricated device.

The measured microwave reflection S₁₁ spectrum as shown in Fig. 21c shows a distinct feature with a free spectral range of approximately 350 MHz that coincides with the peaks appearing on the optical transmission spectrum S₂₁. This response shows a large signal-to-noise ratio (SNR) that is significantly higher in magnitude as compared to the response of bulk devices. The small resonances from Si substrate HBAR as presented in S₁₁ are significantly reduced in the optical transmission S₂₁, since the Si HBAR is mainly located at the outer anchor region that is far away from the inner Si₃N₄ ring.

By synchronously driving multiple piezoelectric MEMS actuators, bulk acoustic waves are generated electromechanically, which can couple to and deflect light propagating in the Si₃N₄ waveguide beneath them. While magnetic-free optical isolators have been shown before, this is the first one that is driven electrically and operated in the linear optical regime. The Si₃N₄ microresonator is designed to support two optical eigenmodes, *a* and *b*, with frequency differences matching a mechanical/acoustic resonant frequency, as shown in Fig. 22b. The microwave drive applied on the three AlN actuators creates acoustic waves inside the mechanical cavity, which scatters light between modes *a* and *b* (i.e. indirect interband transition). Fig. 22c illustrates the ω -*k* space. To induce interband transition, energy and momentum conservations must be satisfied. With a nonzero phonon momentum k_m , phase matching requires $\Delta\omega_{ba} = \omega_b -$

$\omega_a = \Omega_m$ and $\Delta k_{ba} = k_b - k_a$. In the forward direction, the two optical modes undergo interband transition with a scattering rate $g = g_0\sqrt{n_c}$, where g_0 is the single phonon-photon coupling rate describing the optomechanical interaction strength, and n_c is the steady-state intra-cavity phonon number. $C = 4g^2/\kappa_a\kappa_b$ is the optical-to-optical cooperativity, which measures the ratio of scattering rate to optical losses. Strong coupling requires $C \gg 1$, and can lead to Rabi oscillation and mode splitting. The latter results in a transparency window on the resonance in the light transmission in the forward direction. In the backward direction where the three-wave phase matching is not fulfilled, the interband transition is prohibited, leading to $C \ll 1$ and transmission is zero in the critical coupling regime. This non-reciprocal transmission between the forward ($T = 1$) and backward directions ($T = 0$) is the basis of our optical isolator.

We use the high efficiency of the undercut HBAR to demonstrate magnet-less optical isolator by breaking reciprocity via spatiotemporal modulation. We achieve an optical cooperativity $C = 1$ with 14 dBm RF drive power applied on each actuator, and maximum isolation ratio of 10 dB and a minimum insertion loss of 0.1 dB with 20 dBm RF power. An isolation bandwidth of 700 MHz is obtained, primarily determined by the optical resonance linewidth. Hence, to demonstrate a greater isolation ratio with larger bandwidth, we use an over-coupled device, achieving 41 dB isolation and 1.9 dB insertion loss under 2-Watt total RF power.

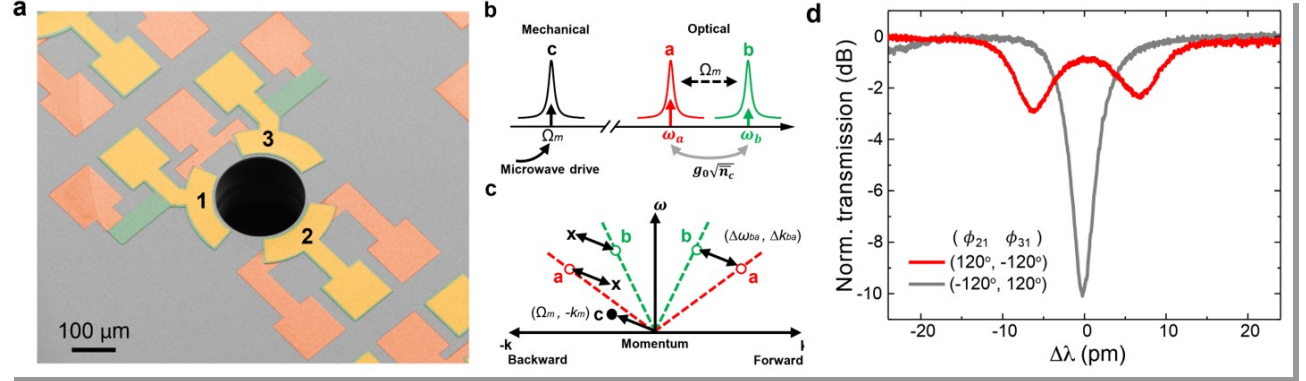

Fig. 22. (a) A false-colored top-view SEM image of the fabricated device. (b) A frequency-domain representation illustrating the indirect interband transition. (c) A schematic of ω - k space showing the phase matching condition, that is, the energy and momentum conservations. (d) Optical transmission spectra with perfect phase matching (red) and largest phase mismatch (grey).

Coherent interconversion between microwave and optical frequencies can serve as both classical and quantum interfaces for computing, communication, and sensing. During this program, we demonstrated a compact microwave-optical transducer based on monolithic integration of piezoelectric actuators atop silicon nitride photonic circuits (Fig. 23). Such an actuator directly couples microwave signals to a high-overtone bulk acoustic resonator defined by the suspended silica cladding of the optical waveguide core, which leads to enhanced electromechanical and optomechanical couplings. At room temperature, this triply resonant piezo-optomechanical transducer achieves an off-chip photon number conversion efficiency of 1.6×10^{-5} over a bandwidth of 25 MHz at an input pump power of 21 dBm. The approach is scalable in manufacturing and, unlike existing electro-optic transducers, does not rely on superconducting resonators. As the transduction process is bidirectional, we further demonstrate synthesis of microwave pulses from a purely optical input. Combined with the capability of leveraging

multiple acoustic modes for transduction, the present platform offers prospects for building frequency-multiplexed qubit interconnects and for microwave photonics at large.

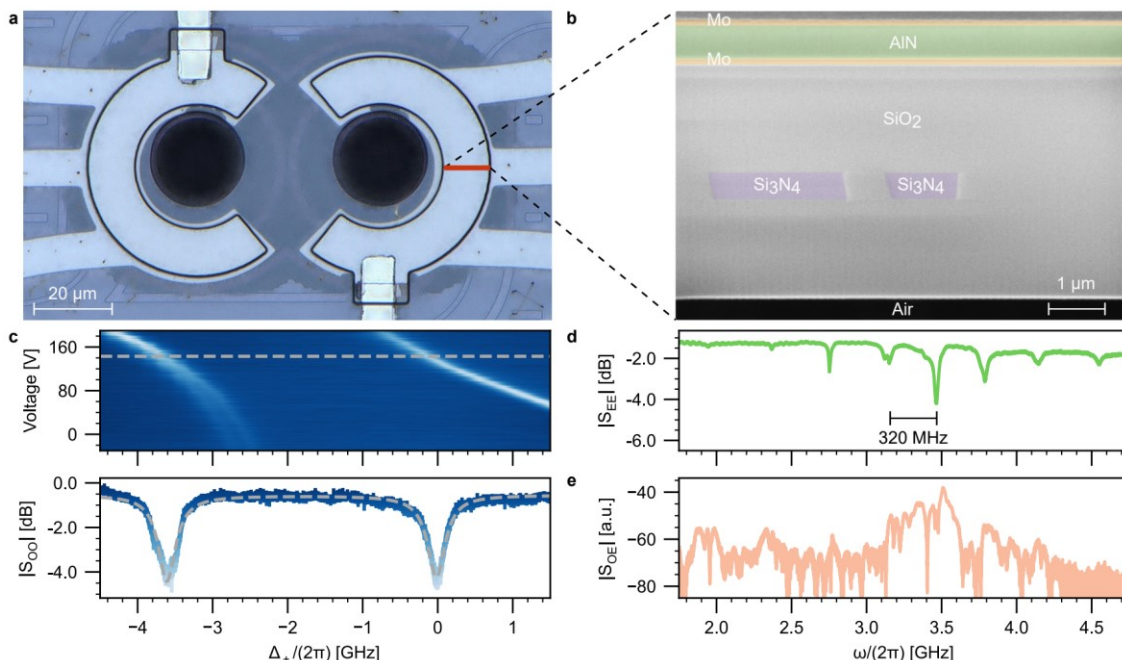

Fig. 23. (a) Optical micrograph of the transducer. The shaded region originates from the released silicon substrate. (b) False-color cross section of the device imaged by focused ion beam scanning electron microscopy showing the top and bottom electrodes (Mo; yellow), piezoelectric layer (AlN; green), suspended cladding (SiO₂; gray), and optical waveguides (Si₃N₄; purple). (c) Optical transmission spectra near 1550 nm as a function of applied DC piezoelectric control voltage and detuning from the antisymmetric supermode. The transmission color map follows the representative spectrum in the bottom panel. The dashed line denotes the best-fit transmission to coupled mode theory. (d) Microwave reflection spectrum indicating locations of the HBARs. (e) Acousto-optic response spectrum with an off-chip optical pump power $P_{in} = 16$ dBm centered at the symmetric supermode.

We measured the off-chip efficiency η^{tot} of the microwave-to-optical (up-conversion) and optical-to-microwave (down-conversion) processes as a function of off-chip CW input optical pump power P_{in} . Compared to the on-chip efficiency η^{oc} , this efficiency also accounts for the loss channels of the microwave and optical ports. First, we study the transducer in the triply resonant configuration. For up-conversion, the optical sideband generated from the microwave input, detuned by $\omega_{in} = \omega_m$ from the pump frequency, is measured via a self-calibrated heterodyne detection method. The off-chip optical output containing both the pump (ω_L) and the sideband (ω_s) is combined with a local oscillator (LO; ω_{LO}) and detected. By placing the LO at a frequency $\omega_{LO} = (\omega_L + \omega_s) / 2 + \delta$ such that the photodetector response is constant over a frequency span of δ , we determine the sideband power relative to the pump. Picking off a fraction of the optical output then enables the determination of its absolute power and, by extension, that of the sideband with a power meter. The measured optical sideband power is compared to that of the microwave input to yield η^{tot} . In the case of down-conversion, the optical input is generated by modulating the phase of the pump with an electrooptic modulator (EOM)

driven by a microwave source of frequency $\omega_{\text{EOM}} = \omega_m$. Only one of the resulting sidebands is admitted into the photonic molecule and transduced, as the other is far off-resonance. Summarized in Figs. 24a and c, bidirectional transduction processes corresponding to both the effective beam-splitter ($\omega_L = \omega_-$; anti-Stokes) and two-mode-squeezing ($\omega_L = \omega_+$; Stokes) interactions are investigated. We reach a maximal η^{tot} of -48 dB at 21 dBm pump for each configuration. Knowing the port losses, we estimate an on-chip efficiency $\eta^{\text{oc}} = -41$ dB. Accounting for the extraction efficiency η^{ext} , we further obtain an internal conversion efficiency $\eta^{\text{int}} = 2 \times 10^{-3}$.

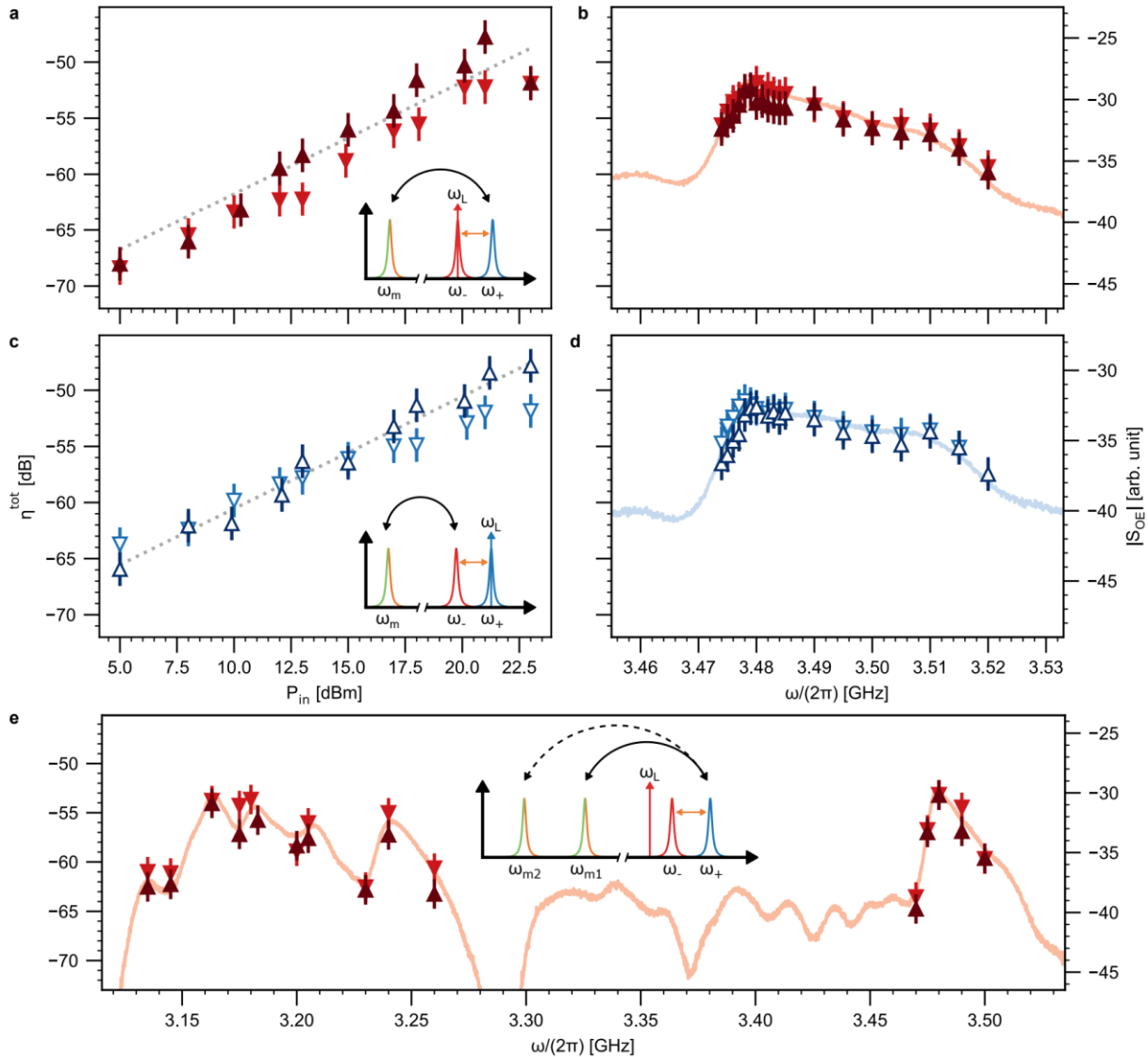

Fig. 24. (a), (b) Anti-Stokes transduction. (c), (d) Stokes transduction. Off-chip efficiencies as a function of off-chip input pump power in the triply resonant configuration are shown in the left panels. Off-chip efficiencies as a function of input microwave frequency and input optical detuning are plotted in the right panels, which depict the transduction bandwidth. (e) Bidirectional transduction with a detuned pump leveraging multiple HBAR modes, as a function of input microwave frequency and input optical detuning. Up- and down-conversion efficiencies are denoted by triangles and inverted triangles, respectively, with the corresponding acoustic-

optic response spectrum superimposed. The markers are empty for Stokes processes and filled for anti-Stokes processes. The dotted lines represent the best-fit efficiency in the low-cooperativity regime where $\eta_{\text{tot}} \propto C \propto P_{\text{in}}$. The insets illustrate the respective configurations for both the pump and input signal.

Furthermore, we deviate from triple resonance to map out the transduction bandwidth. First, for a pump still resonant with one of the optical supermodes, the input microwave frequency ω_{in} and input optical detuning (controlled by EOM drive frequency ω_{EOM}) are varied for up- and down-conversion, respectively. Shown in Fig. 24b and d, transduction leveraging the main transduction mode exhibits a full width at half maximum (FWHM) of 25 MHz. The multimode nature of the transducer is further manifest in Fig. 24e, where the pump is in the beam-splitter configuration but slightly detuned from \hat{a}^- . An additional transduction peak in η^{tot} with a FWHM of 10 MHz is observed around $\omega_{\text{in}} = 2\pi \times 3.165$ GHz, which corresponds to another HBAR one FSR away from the main transduction mode $\omega_{\text{m}} = 2\pi \times 3.480$ GHz. The engineering degrees of freedom such as cladding and actuator thickness (HBAR FSR), and optical dispersion (supermode splitting as a function of optical wavelength) in the present system offer possibilities for frequency multiplexed transduction.

The “Pull-back process” for fabrication of electrodes was engineered to minimize the capacitance of bond-pads and for the ease of wire-bonding to the bond-pads and thereby helping in impedance matching with the microwave. As shown in Figure 25a, we start with a layer stack of top Mo, AlN, and bottom Mo on top of the SiO₂. We have used deep reactive-ion etching to pattern the Mo and AlN layers. Prior to the pullback process, the top-electrode bond pad had a layer of AlN and bottom Mo underneath it, creating a capacitor. Given the width of the bond pad is more than double the width of the device itself, the capacitance added is significant and should be avoided to reduce the RC time constant. We can eliminate the capacitance by etching through the top Mo, AlN, and bottom Mo layers and depositing a layer of Al to connect the top electrode bond pad.

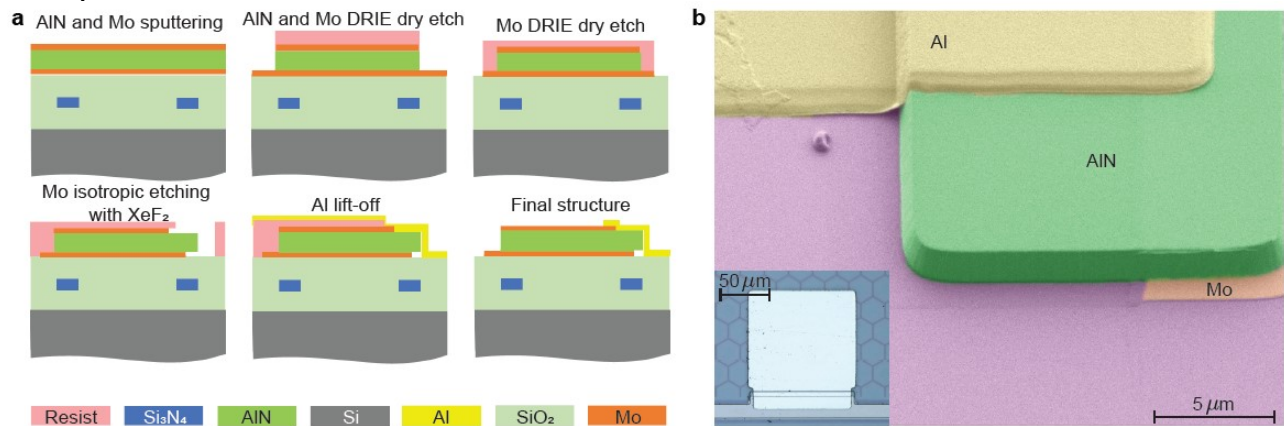

Fig. 25. Pull-back fabrication process. (a) Process flow of the fabrication. (b) False-colored SEM image of the electrodes fabricated by this fabrication technique. The inset is a photograph taken by an optical microscope of the top electrode.

However, the deposited Al must be electrically isolated from the bottom Mo. Thus, we add the “Pull-back” step for which the process is named to create an air gap between the top and bottom metals. XeF₂ etches Mo but has a near infinite selectivity with AlN. Therefore, using an isotropic etching process, the Mo can be slightly etched away without harming the AlN. We “Pull-back”

the Mo from underneath the AlN between 1 and 2 μm , and then deposit a layer of Al with a lift-off process. A glancing angle deposition tool evaporates 200 nm of Al with a 15° angle on a rotating plate to make sure the Al covers the 1 μm AlN step height. The final result is a gap of air between the bottom Mo and top Al leaving them electrically isolated, but Al is electrically connected to the top Mo layer. Figure 6(b) shows a trial of this technique, and it can be seen that the Mo has been pulled back from underneath the AlN and the Al has been deposited on top and fully covers the step height of the AlN. In this trial, Al served as the entire top metal without top Mo, however the device described in this work has a layer of top Mo between the Al and AlN layers.

Finally, as an exciting development in the context of synthetic lattices based on time-modulation, we demonstrated the experimental realization of controllable microwave photon dynamics in a synthetic lattice. This was implemented through parametric coupling between modes of a superconducting CPW resonator modulated at the mode spacing frequency. Photons propagate between resonance sites in this artificial lattice, simulated using a single hardware-efficient device. Effects like Bloch oscillations were observed by controlling the modulation parameters. This platform enables studying complex wave dynamics by leveraging temporal modulations. To move beyond controlling photons in a simple linear meta-material, we attempted to understand the potential of time-modulation in realizing quantum codes. For this, we developed novel adjoint optimization techniques to automatically discover autonomous quantum error correction (AQEC) schemes for given superconducting circuit architectures. The approach involves numerically optimizing over both a proposed logical encoding subspace and additional control parameters to maximize preservation of quantum information. By extending concepts of adjoint optimization from photonics into the quantum regime, this framework provides a means to engineer protected qubit dynamics purely through modulation, without the need for active error syndrome measurements and corrections.

When applied to a hardware-realistic model consisting of a lossy bosonic mode coupled to a qubit, the optimization discovered AQEC schemes that extend the qubit coherence time beyond the lifetime of any individual component. The discovered codes depend on the graph connectivity between states in the full Hilbert space dictated by the Hamiltonian. This demonstrates the power of the technique to tailor protection to a given physical system. By automating the design of AQEC schemes, this work opens up new possibilities for realizing ultra-coherent quantum memories and logical operations. It provides a platform for further exploring Floquet engineering of quantum dynamics with minimal hardware overhead.

Most recently, we moved even beyond the parametric limit of modulation paradigm to systems where the modulation completely renormalizes the energy levels and results in qualitatively new phenomena. In this direction, we invented the Kapitzonium, a new superconducting qubit that goes beyond the usual parametric modulation approaches to achieve intrinsic protection of its quantum states. It consists of a SQUID loop circuit driven by an alternating flux bias. Unlike a conventional parametric drive which modulates a single parameter, the Kapitzonium uses strong periodic modulation to fundamentally transform the energy landscape, generating an effective double-well potential. The qubit basis states are formed from the localized wavefunctions in the two wells, representing macroscopically distinct superpositions of clockwise and counter-clockwise persistent current states. This is a quantum version of the classic Kapitza pendulum, where modulation stabilizes the inverted pendulum position. Similarly, the rapid modulation protects the localization against decoherence processes like spontaneous emission that cause transitions between the wells.

Furthermore, a passive cooling mechanism is introduced using a filter cavity to prevent leakage out of the qubit subspace spanned by the 0 and π states. This cooling mitigates a key challenge in realizing robust Floquet systems. Together, these innovations present a realizable circuit-QED architecture that intrinsically protects qubit states through microwave time-modulation engineered dynamics. It provides a promising route towards high-fidelity quantum control and long-lived quantum memory. The Kapitonium illustrates the transformative opportunities unlocked by extending Floquet engineering beyond parametric approaches.

Thrust 3: Nanophotonic circuits and systems

Our efforts on time-varying metamaterials for nonreciprocity and extreme wave phenomena have not been limited to the radio-frequency domain. We have also explored exciting opportunities in nanophotonics. As an important breakthrough in this quest, in the first years of the MURI program, we introduced "nano-bender" piezoelectric actuators to enable low-voltage optomechanical tuning in lithium niobate devices. These transducers exploit the d_{31} piezoelectric coefficient to generate a quadratic displacement response. When integrated with photonic resonators, they enable optical resonance shifts exceeding one linewidth using only 10 mV drive voltages – and incredibly small V_{pi} . The nano-benders provide a path towards dense integration of mechanical tuning elements without requiring high voltages or large power consumption. Building on the improved lithium niobate material platform, efficient acousto-optic interactions were demonstrated in 2020 using wavelength-scale waveguides. By confining both GHz acoustic and 1550 nm optical waves, a collinear acousto-optic modulator was realized with a figure of merit improved by nearly 3 orders of magnitude compared to previous integrated devices. This compact, low-power acousto-optic architecture is promising for on-chip isolators, tunable RF filters, and beam deflectors.

Leveraging the electro-optic effect in lithium niobate, we demonstrated non-reciprocal frequency circulation in an integrated photonic circuit. The device consists of three coupled racetrack resonators, whose modes are hybridized into a 3-level system. Dynamic refractive index modulation converts light between modes selectively based on direction. Over 25 dB of optical isolation was measured, demonstrating the power of time modulations for breaking reciprocity (Fig. 26).

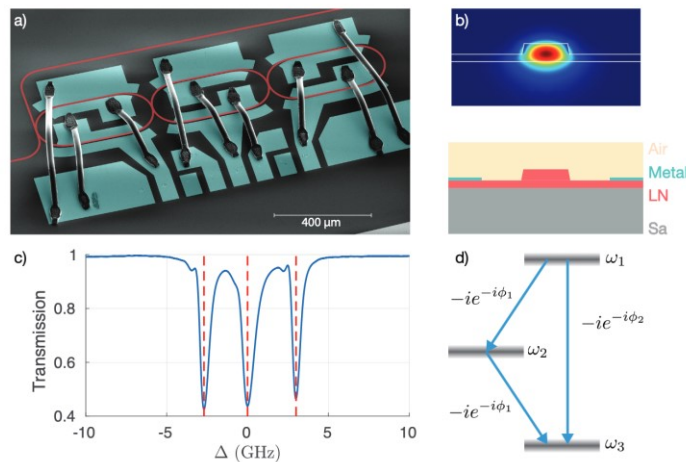

Fig. 26. An optomechanical photonic circulator.

In parallel, phononic integrated circuits for routing and processing microwave acoustic waves were realized. GHz frequency phonons were confined and propagated in lithium niobate waveguides, with efficient electromechanical transducers enabling multiple ports. This opens up new possibilities for engineering chip-scale acoustic wave devices for classical and quantum applications.

We also proceeded to develop a new type of device by building on the conceptual advances realized through this program, particularly on synthetic lattices and lithium niobate photonics. In 2023 an integrated frequency-modulated OPO microcomb was demonstrated, which combines the electro-optic and $\chi(2)$ nonlinear properties of lithium niobate. This novel device consists of a lithium niobate microring resonator with integrated modulation electrodes. Through the electro-optic effect, the resonant frequencies of the cavity modes are modulated over time. Simultaneously, continuous-wave 1550nm pump light is coupled into the resonator. The modulation enables parametric down-conversion to sidebands spaced by the modulation frequency, generating hundreds of oscillating comb lines. Importantly, the modulation bandwidth exceeds the cavity linewidth by over two orders of magnitude. This allows the comb lines to experience a spectrally flattened, "frequency-modulated" gain profile, overcoming the typical spectral shape limitations of parametric combs.

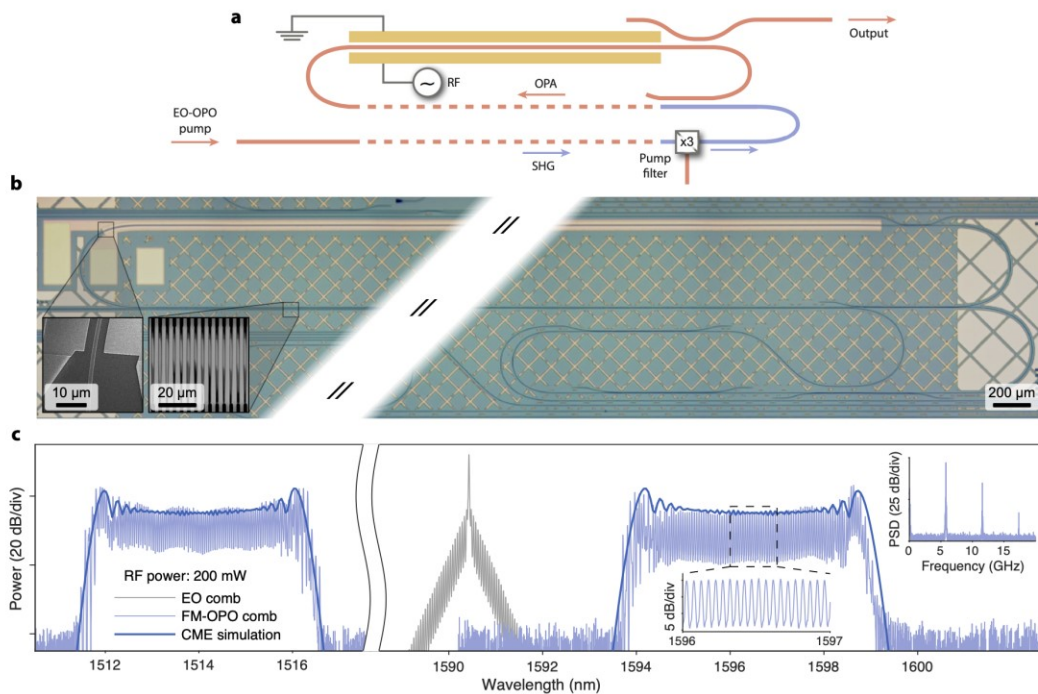

Fig. 27. An integrated frequency-modulated OPO microcomb.

The resulting integrated FM-OPO (Fig. 27) demonstrated over 1000 comb lines spanning 100 nm, with a conversion efficiency exceeding 90% from the pump to the comb – a significant improvement over competing Kerr and EO combs. The devices operate stably at room temperature with only milliwatts of pump power. Furthermore, the complete system including pump generation and filtering is realized on a single lithium niobate photonic chip. This accomplishment introduces a new class of efficient, broadband, stable microcomb sources requiring no external RF or optical references. It promises compact tools for dual-comb spectroscopy, wavelength-division multiplexing, optical arbiters for beamforming, and other

applications. The high efficiency, broad bandwidth, and robust dynamics are enabled by synergistically combining concepts of frequency modulations, integrated photonics, and nonlinear optics through temporal modulations.

Additional team achievements based on time-modulated metamaterials were focused on the demonstration of an alternative route to efficient excitation and energy storage inside a resonator, by tailoring the excitation signal and shaping the incoming pulse in time, rather than changing the system geometry. Our approach is based on virtual critical coupling, discussed in the previous sections, which is rooted in the scattering response of resonant systems driven by impinging waves oscillating at tailored complex frequencies. By tuning the complex frequency excitation, it is possible to induce an effect analogous to introducing either material gain or loss, enabling a generalized form of critical coupling that supports tunable and efficient resonant excitation without having to physically manipulate the system parameters. As the resonator reaches a quasi-steady state response, oscillating at the same complex frequency as the excitation signal, its intrinsic loss rate is controlled by the imaginary part of the complex frequency. Here, we theoretically and experimentally demonstrate that we can leverage this control to tune the resonator loss rate, achieving critical coupling and hence enhancing the efficiency with which we can couple light to nanoscale photonic resonances.

By exciting at a complex frequency, we can tune the system to meet the virtual critical coupling condition, hence exciting the overcoupled cavity more efficiently. The orange curve of Fig. 28(c) illustrates the temporal evolution of the squared magnitude of the transmission coefficient and we indeed observe that its response is identical to the response of the critically coupled resonator achieved in the CW regime with the right geometry. In addition, by adiabatically varying in time the growth rate of impinging signals, we may dynamically control the effective intrinsic loss, varying the coupling regime. Figure 29 provides an illustrative example of this control, showing three transmission dispersions calculated for different values of τ_{in} for the same resonator, resulting in virtual critical coupling at $\tau_{in} = \tau_{crit}$ (orange), virtual overcoupling (blue) at $\tau_{in} = 10 \tau_{crit}$, and virtual undercoupling (red) at $\tau_{in} = 0.2 \tau_{crit}$.

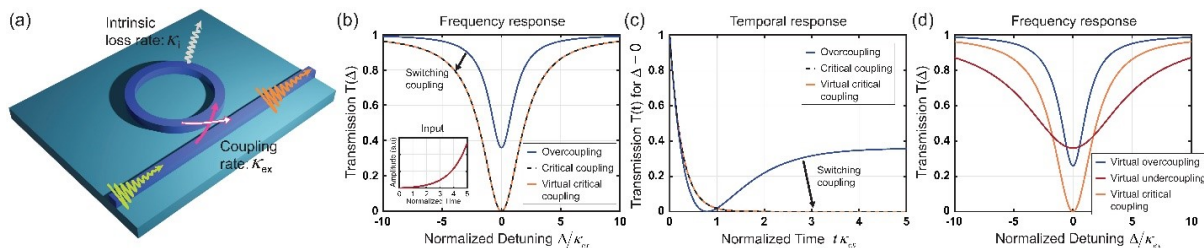

Fig. 28. An illustrative example of virtual coupling control, showing three transmission dispersions calculated for different values of τ_{in} for the same resonator, resulting in virtual critical coupling at $\tau_{in} = \tau_{crit}$ (orange), virtual overcoupling (blue) at $\tau_{in} = 10 \tau_{crit}$, and virtual undercoupling (red) at $\tau_{in} = 0.2 \tau_{crit}$. Figure 2 shows sequence of input I_{input} and output I_{output} intensities for various pulse time constants. The energy stored in the resonator during the pulse decays partly into the bus waveguide and is observed as a sharp peak once the pulse ends.

Clearing a path for light through lossy media In non-Hermitian systems. Active photonic devices suffer from a tradeoff between required performance and high propagation losses due placement

of lossy materials in waveguide proximity. Here we show a method that overcomes this tradeoff and allows the metal to be placed in close proximity to waveguides without introducing additional losses in non-Hermitian systems. In order to do this, we rely on creating a low-loss light path through a lossy media, for the fundamental propagating mode, while redistributing the losses to the other modes in the system using the physics of non-Hermitian states. We create a coupled non-Hermitian waveguide system using a single $10\ \mu\text{m}$ wide multimode silicon waveguide partially covered with a lossy metal film. The coupling rate between the modes and the material loss in the coupled system is controlled by changing the width of the metal film covering the waveguide. The computed propagation losses of the few supported modes are shown in figure 30b as a function of material loss. One can see that for a sufficiently high material loss (shaded region in figure 30b), propagation loss of the low-order modes decreases with increase of loss while propagation loss of a certain higher order mode increases. In this case, the fundamental mode exhibits propagation loss many orders of magnitude lower than the system loss present in part of the non-Hermitian waveguide. In this computation, we have assumed an overall unclad silicon waveguides with a partial cladding of Aluminum metal with width $w_m = 1.2\ \mu\text{m}$. By varying the distance of the cladding film and its thickness we achieve required material loss variation of $40\ \text{dB/cm} - 7 \times 10^4\ \text{dB/cm}$. Mode profiles of the low and high loss modes are shown in the inset iv, v, vi. One can see that the low and high loss modes are confined to the corresponding low loss regions of the multimode waveguide.

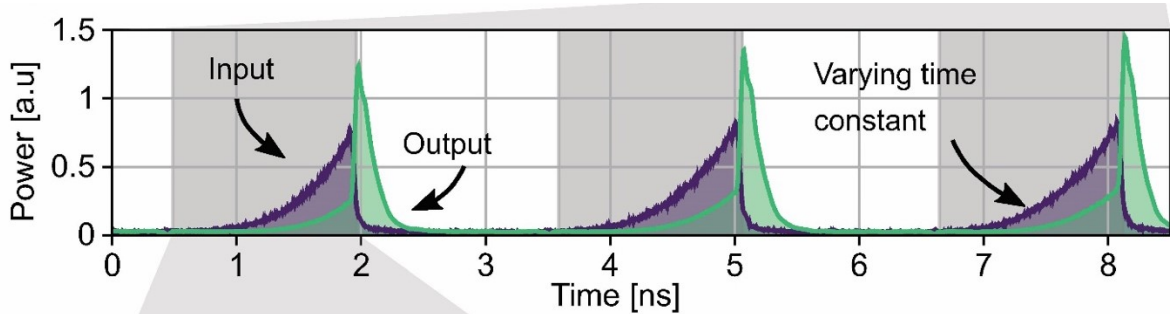

Fig. 29. Sequence of input I_{input} and output I_{output} intensities for various pulse time constants. The energy stored in the resonator during the pulse decays partly into the bus waveguide and is observed as a sharp peak once the pulse ends

We measured propagation loss of $1.2 \pm 0.6\ \text{dB}$ in the fundamental mode at a probe wavelength of $1600\ \text{nm}$, for a $10\ \mu\text{m}$ wide SOI waveguide with partial metal cladding. The Aluminum metal cladding has a width $w_m = 3.6\ \mu\text{m}$, and thickness $t_m = 120\ \text{nm}$, placed directly on top of the waveguide. In order to measure the propagation loss of the fundamental mode of non-Hermitian waveguide, we embed our partially metal clad multimode silicon waveguide in one of the arms of a length unbalanced Mach-Zehnder interferometer (MZI). The MZI is made of single mode silicon waveguides with width $w = 450\ \text{nm}$, and the multimode waveguide section in one of the arms runs for a length of $l_{MM} = 75\ \mu\text{m}$. The optical transmission of the composite MZI structure is recorded in the entire telecommunication band and subsequently the insertion losses of the entire device is estimated by fitting the spectral data (to MZI equation).

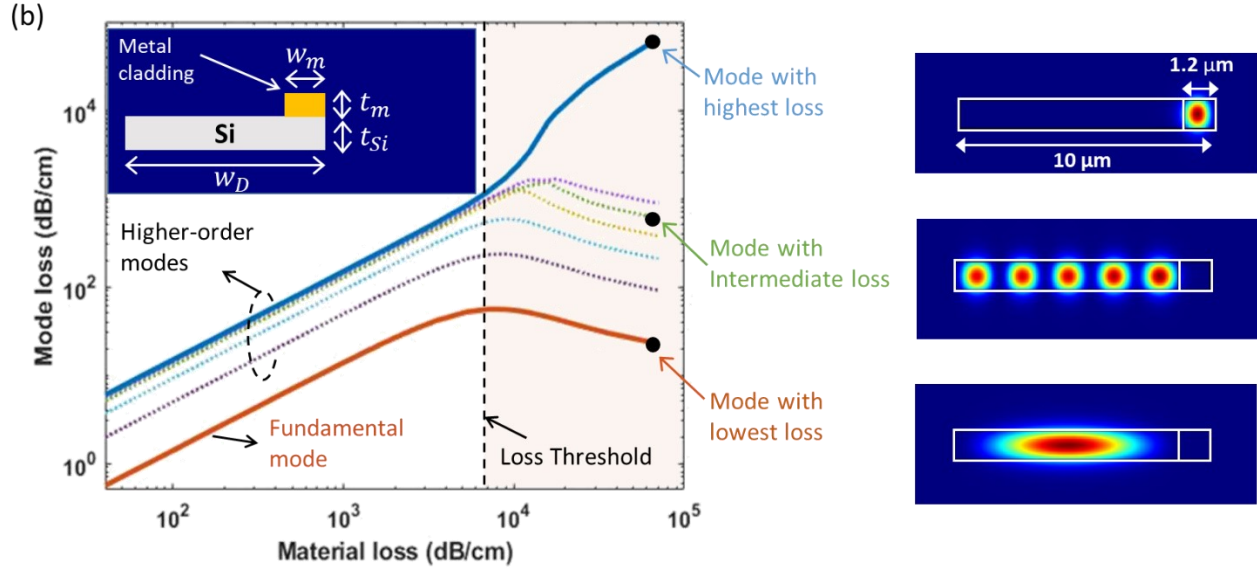

Fig. 30. (a) A non-Hermitian system consisting of two identical coupled waveguides having widths $w_1 = w_2 = w$, and coupling rate κ . The waveguides have equal propagation constants $\beta_1 = \beta_2$, but distinct losses $\gamma_1 = 0$, and $\gamma_2 > 0$. The loss in the waveguide wg_2 is introduced by placing a metallic film in its vicinity (inset-i). The chart shows, evolution of mode loss for the first symmetric (red line) and asymmetric (blue line) mode of a coupled waveguide system as a function of waveguide's intrinsic material loss (i.e. $\Delta\gamma = \gamma_2 - \gamma_1$). The plot axis are normalized with respect to the coupling rate κ . When $\Delta\gamma = \kappa$, the two mode losses converge resulting in an exceptional point (EP), represented by yellow circle on the plot. Beyond this point, increase in $\Delta\gamma$ ($\Delta\gamma \gg \kappa$) leads to decrease in mode losses for the asymmetric mode and increase in loss for symmetric mode. The broken lines represent the mode evolution if the two waveguides in the coupled system are non-identical (i.e. $\Delta\beta = \beta_1 - \beta_2$). For this simulation we consider conventional silicon waveguides with widths $w_M = 450$ nm, and sweep the loss in wg_2 at single wavelength of simulation. The insets ii and iii, present the high and low loss modes of a coupled silicon waveguide system. The two coupled waveguide shown here, have equal dimensions ($w = 5 \mu\text{m}$, $h = 220$ nm, $\beta_1 = \beta_2$), and unequal losses ($\gamma_1 \neq \gamma_2$) resulting in $\Delta\gamma > 0$. The losses are introduced by placing metal cladding on wg_2 for a width $w_M = 200$ nm. **(b)** Similar to (a), coupled waveguide system with unequal waveguide losses can also be created by a wide waveguide with partial metal cladded region (inset). The plot shows propagation losses of various modes of a wide multimode silicon waveguide as a function of intrinsic material loss. In this case the material losses are introduced by altering the distance between the partial metal cladding and the silicon waveguide. The loss threshold value for creating of modes with distinct losses, is approximately $\sim 7 \times 10^3$ dB/cm. In this case, beyond the loss threshold, a low loss mode emerges presenting a propagation loss ~ 22 dB/cm, even when the material loss is $\cong 7 \times 10^4$ dB/cm. Here, in order to introduce waveguide losses, we consider Aluminum as partial cladding material. The simulation results shown here are performed at a single wavelength $\lambda_0 = 1550$ nm, however similar results can be generated for any operating wavelength.

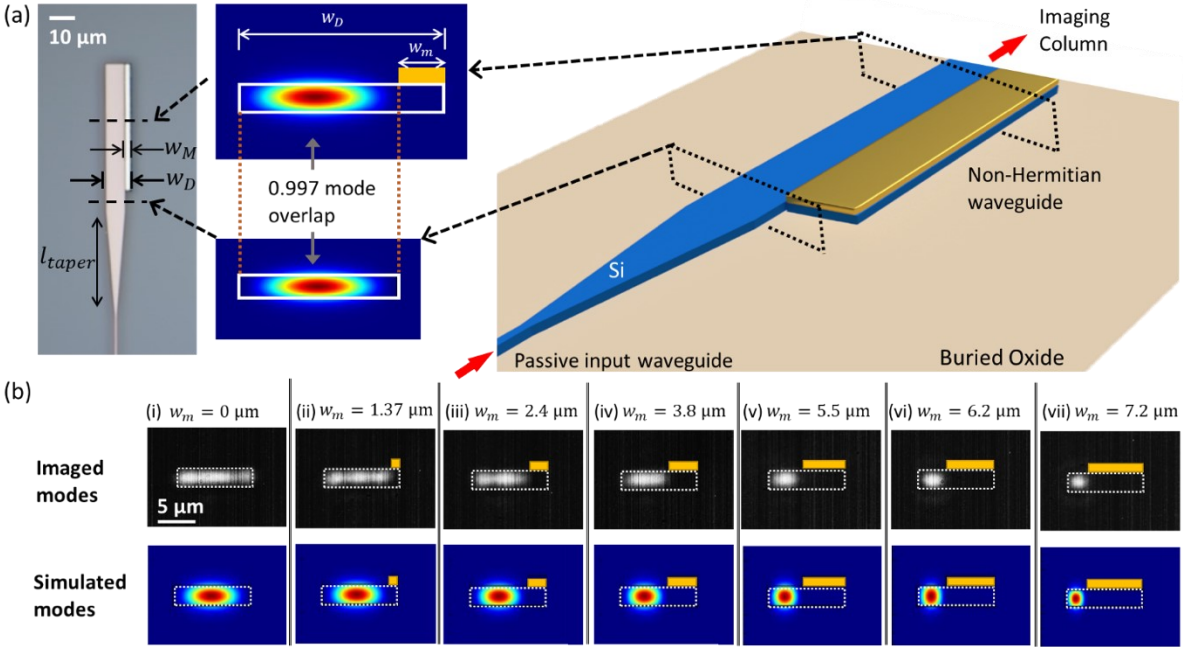

Fig. 31. (a) Left panel shows the microscope image of different components of the device used for demonstrating that the fundamental mode is confined solely to the low-loss region. The device consists of single mode silicon waveguide ($w_{SM} = 450$ nm), the waveguide taper ($l_{taper} = 30$ μm) from single mode width to unclad region of multimode waveguide, the unclad multimode waveguide ($w_D = 10$ μm), and the non-Hermitian waveguide with partial (w_m) Aluminum cladding. The taper is used to excite the fundamental low loss mode of the non-Hermitian waveguide. Not shown here are the input waveguide taper ($w_{input} = 180$ nm) to couple light to the single mode waveguide. Middle panel, shows simulated fundamental mode of unclad multimode waveguide, and the low loss mode of the non-Hermitian waveguide, along with their mode overlap ($\Gamma_{overlap} = 0.997$). Right panel – Sketch of input and output to the non-Hermitian waveguide used to image the modes. **(b)** Modes of non-Hermitian waveguides with a silicon waveguide width of $w_D = 10$ μm , and partial Aluminum cladding width (w_m) ranging from 0 to 7.2 μm with a thickness of $t_m = 120$ nm for columns (i) to (vii). Top row panels show the experimentally imaged mode while the corresponding panel in bottom row represents the simulated mode profile of waveguide with equivalent dimensions of w_D and w_m . The simulation results shown here are obtained using Lumerical MODE solutions at the wavelength corresponding to the measurement wavelength $\lambda_0 \sim 1600$ nm.

Conventional dielectric waveguides rely on total internal reflection to guide the light in the material with the highest refractive index, thereby limiting the light-matter interaction in materials exhibiting a lower index. The few options available to access the properties of low-index materials include designs that are either lossy, periodic, exhibit limited optical bandwidth, or are restricted to subwavelength dimensions. Here, we propose novel guiding mechanisms that leverage symmetry in dielectric waveguides to overcome all these limitations. We show a waveguide structures exhibit very unusual light properties, such as uniform field distribution with a non-Gaussian spatial profile and the scale invariance of the optical mode. These properties

enable light propagation in the lower-index material and also control the strength of the light-matter interaction. By employing ray-optics concepts, we show that the guiding mechanisms emerge at the critical angle and below it and are characteristics of surface and refracted propagating rays. We experimentally demonstrate guiding in the low-index material and the scale invariance of optical mode by measuring the effective index for waveguides with different heights. We confirm the non-Gaussian uniform field distribution of our waveguide at the critical angle by measuring the transverse mode profile that shows that most of the light is concentrated in the lower-index material. The novel guiding mechanisms are very general and can be further extended to various structures, such as circular waveguides, and employed for different polarizations and wavelengths. Therefore, our results can have huge implications for integrated photonics and related technologies.

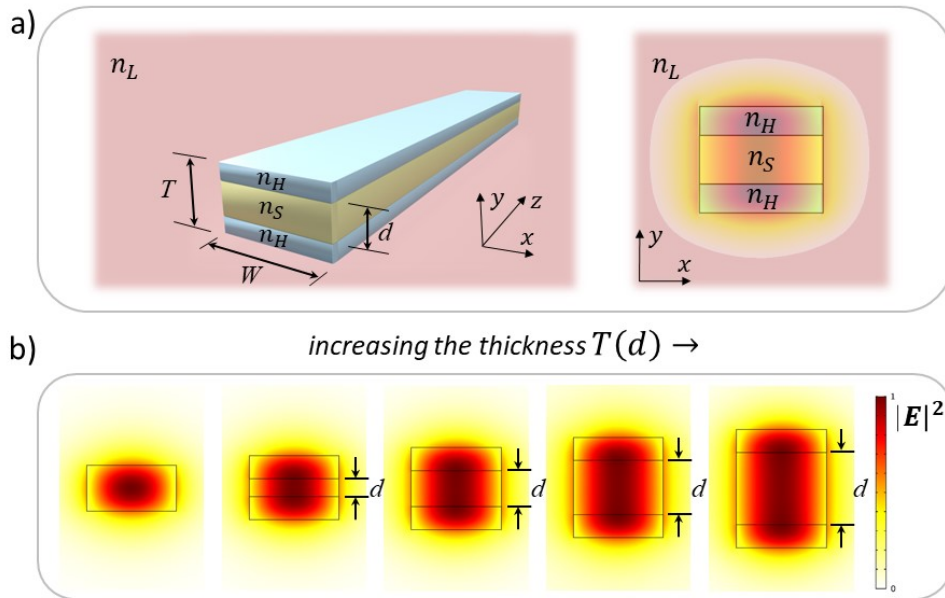

Fig. 32. Unusual light properties of the X waveguide. **(a)** 3D geometric schematics of the X waveguide formed by a middle layer of the intermediary-index material, (n_S), sandwiched between two layers of the higher-index material, (n_H), surrounded by the lower-index material cladding, (n_L). The X waveguide shows a uniform field distribution in the vertical direction in contrast with the gaussian-like distribution in the strip waveguide. **(b)** The electric field intensity distribution of the X waveguide as a function of the middle layer thickness d , showing the vertical scale invariance of the optical mode.

In this program, we introduced a novel guiding mechanism that harnesses evanescent radiation modes propagating in low-index material without importing their intrinsic losses. We explore the topological protection ensured by symmetry in order to gain access to these previously inaccessible lossless regimes. This guiding mechanism benefits from uniform field distribution in the low-index material with a non-Gaussian profile and from the scale invariance of the optical mode, which facilitates full control of the strength of the light-matter interaction process. We show that the design is robust to fabrication variations, is broadband, is polarization-independent, and most importantly, introduces no additional optical loss. The structure consists of two high-index materials of thickness t and refractive index n_H separated by an intermediary-index material of thickness d and index n_S and cladded by a low-index material with index n_L , where $n_H > n_S > n_L$ (see figure 32(a)). The electric field E propagating along the z -direction inside of

the middle layer ($-d/2 \geq y \geq +d/2$) has spatial dependence in the y -direction given by $E(y) = |E_0| \cosh(k_S y)$, where $|E_0|$ is the electric field maximum amplitude and k_S is the transverse wavevector. The transverse wavevector is related to the mode effective index (n_{eff}) and the wavevector magnitude ($k_0 = 2\pi/\lambda_0$) through the relation $k_S = \pm k_0 \sqrt{n_{eff}^2 - n_S^2}$, where λ_0 is the wavelength of the light in vacuum. For the conventional regime where light is confined to the highest-index materials, k_S is pure real ($n_{eff} > n_S$) and the field distribution represents an evanescent field decay inside the middle region (see figure 32(b)). On the other hand, when k_S is null ($n_{eff} = n_S$) the solution is a uniform field throughout the middle layer, $E(y) = |E_0|$ and does not depend on its size (see figure 32(c)). Furthermore, when k_S is imaginary ($n_{eff} < n_S$) the field assumes an unconventional oscillatory behavior, $E(y) = |E_0| \cos(k_S y)$, where the maximum amplitude of the light is concentrated inside the intermediary-index material (see figure 32d).

We characterized the transverse mode profile of the X waveguide and confirm the non-Gaussian uniform field distribution. In order to measure the near-field modes' spatial profiles, we use a z-scan approach, assisted by a tapered nanofiber and nanopositioner to determine the mode profiles in different regions. We selected the two thickest waveguides, one of each, both with $T = 1450$ nm. We extract the mode profiles of both waveguides by using a deconvolution algorithm (See methods section and the supplementary material section Z). Figure 33(a-b) expected mode profile obtained from the FDTD simulation of the fundamental (TE) mode distribution of the standard SIN waveguide and its measured mode profile showing its normal Gaussian-like distribution. Figures 33(c-d) show the expected and measured mode profile for the X waveguide. One can see that in strong contrast to the standard waveguide with its normal Gaussian-like profile, the X-waveguide exhibits a uniform field distribution and most of the light is concentrated in the low-index material

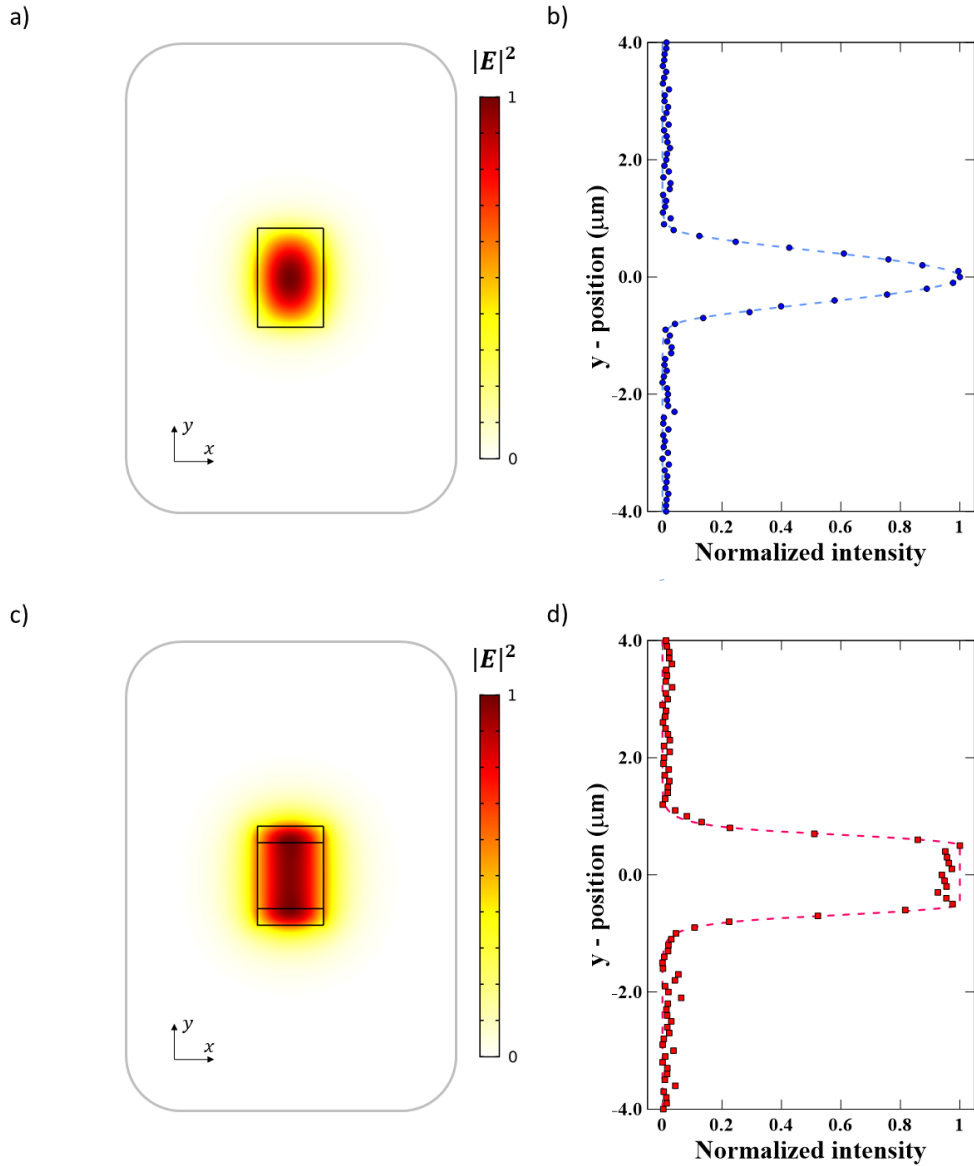

Fig. 33 - Experimental demonstration of the non-Gaussian mode with a uniform electric field intensity near the critical point. (a) FDTD simulation of electric field intensity profiles $|E|^2$ of the fundamental Transverse Electric (TE) mode profile of the strip SIN waveguide. **(b)** Recovered experimental mode profile of SIN strip waveguide showing a conventional Gaussian-like profile. **(c)** FDTD simulation of electric field intensity profiles $|E|^2$ of the fundamental Transverse Electric (TE) mode profile of the proposed new waveguide. **(d)** Recovered experimental mode profile of the new waveguide showing an almost uniform intensity distribution in the middle region.

VIII. Journal Publications Supported by this Program

- J1. E. Mikheeva, R. Colom, K. Achouri, A. Overvig, F. Binkowski, J. Y. Duboz, S. Cuffe, S. Fan, S. Burger, A. Alù, and P. Genevet, *“Asymmetric Phase Modulation of Light with Parity-Symmetry Broken*

- Metasurfaces*,” *Optica*, Vol. 10, No. 10, pp. 1287-1294, October 2023 (published online on September 27, 2023).
- J2. V. Chistyakov, V. S. Asadchy, S. Fan, A. Alù, and A. Krasnok, **“Tunable Magnetless Optical Isolation with Twisted Weyl Semimetals,”** *Nanophotonics*, Vol. 12, No. 16, pp. 3333-3340, August 2023 (published online on July 12, 2023).
- J3. S. Yin, E. Galiffi, G. Xu, and A. Alù, **“Scattering at Temporal Interfaces: An Overview From an Antennas and Propagation Engineering Perspective,”** *IEEE Antennas and Propagation Magazine*, Special Issue on Time Metamaterials, Vol. 65, No. 4, pp. 21-28, August 2023 (published online on April 10, 2023), (*invited paper*).
- J4. A. Alù, **“Metamaterials Embrace the Temporal Dimension,”** *IEEE Antennas and Propagation Magazine*, Special Issue on Time Metamaterials, Vol. 65, No. 4, pp. 6-8, August 2023 (published online on August 10, 2023), (*invited paper*).
- J5. Y. Ra’di, N. Nefedkin, P. Popovski, and A. Alù, **“Metasurfaces for Next-Generation Wireless Communication Systems,”** *National Science Review*, Vol. 10, No. 8, nwad140 (2 pages), August 1, 2023 (published online on May 15, 2023), (*invited paper*).
- J6. G. Xu, A. Overvig, Y. Kasahara, E. Martini, S. Maci and A. Alù, **“Arbitrary Aperture Synthesis with Nonlocal Leaky-Wave Metasurface Antennas,”** *Nature Communications*, Vol. 14, No. 4380 (11 pages), July 20, 2023.
- J7. A. Li, H. Wei, M. Cotrufo, W. Chen, S. Mann, X. Ni, B. Xu, J. Chen, J. Wang, S. Fan, C. W. Qiu, A. Alù, and L. Chen, **“Exceptional Points and Non-Hermitian Photonics at the Nanoscale,”** *Nature Nanotechnology*, Vol. 18, No. 7, pp. 706-720, July 2023 (published online on June 29, 2023).
- J8. S. Yin, and A. Alù, **“Dispersion Braiding and Band Knots in Plasmonic Arrays with Broken Symmetries,”** *Nanophotonics*, Special Issue on Nanophotonics in Support of Ukrainian Scientists, Vol. 12, No. 14, pp. 2963–2971, July 2023 (published online on March 30, 2023), (*invited paper*).
- J9. J. Ferdous, C. Yuce, A. Alù, and H. Ramezani, **“Observation of Robust Zero-Energy Extended States,”** *Physical Review Applied*, Vol. 19, No. 6, L061002, June 23, 2023. [*Letter*]
- J10. H. Moussa, G. Xu, S. Yin, E. Galiffi, Y. Ra’di, and A. Alù, **“Observation of Temporal Reflection and Broadband Frequency Conversion at Photonic Time Interfaces,”** *Nature Physics*, Vol. 19, No. 6, pp. 863-868, June 15, 2023 (published online on March 13, 2023). [*Press release*]
- J11. Z. Sakotic, P. Stankovic, V. Bengin, A. Krasnok, A. Alù, and N. Jankovic, **“Non-Hermitian Control of Topological Scattering Singularities Emerging from Bound States in the Continuum,”** *Laser and Photonics Reviews*, Vol. 17, No. 6, 2200308 (11 pages), June 2023 (published online on March 17, 2023).
- J12. G. Labate, F. Monticone, and A. Alù, **“Generalized Surface Admittance Equivalence Principle for Super-Scattering in Dielectric Particles,”** *Optics Letters*, Vol. 48, No. 11, pp. 3115-3118, June 1, 2023 (published online on May 15, 2023).
- J13. H. Moussa, M. Cotrufo, and A. Alù, **“Controllable Transmission Switch Based on Asymmetric Coupled Nonlinear Resonances,”** *Physical Review Applied*, Vol. 19, No. 6, 064002 (7 pages), June 1, 2023.
- J14. M. Pascale, S. A. Mann, D. C. Tzarouchis, G. Miano, A. Alù, and C. Forestiere, **“Lower Bounds to the Q Factor of Electrically Small Radiators through Quasistatic Modal Expansion,”** *IEEE Transactions on Antennas and Propagation*, Vol. 71, No. 5, pp. 4350-4361, May 2023 (published online on February 28, 2023).
- J15. H. Li, S. Yin, H. He, J. Xu, A. Alù, and B. Shapiro, **“Stationary Charge Radiation in Anisotropic Photonic Time Crystals,”** *Physical Review Letters*, Vol. 130, 093803 (6 pages), March 3, 2023.
- J16. A. Alù, **“Tarnkappen für Licht und Schall,”** *Spektrum der Wissenschaft*, Vol. 3.23, March 1, 2023, (*invited paper*).
- J17. N. Nefedkin, M. Cotrufo, and A. Alù, **“Nonreciprocal Total Cross Section of Quantum Metasurfaces,”** *Nanophotonics*, Special Issue on Quantum Nanophotonics, Vol. 12, No. 3, pp. 589-606, February 10, 2023 (published online on January 9, 2023), (*invited paper*).

- J18. S. Yin, Y. T. Wang, and A. Alù, **“Temporal Optical Activity and Chiral Time-Interfaces,”** Optics Express, Feature Issue on Time Metamaterials, Vol. 30, No. 26, pp. 47933-47941, December 15, 2022, (*invited paper*).
- J19. R. Tirole, E. Galiffi, J. Dranczewski, T. Attavar, B. Tilmann, Y. T. Wang, P. Arroyo-Huidobro, A. Alù, J. B. Pendry, S. A. Maier, S. Vezzoli, and R. Sapienza, **“Saturable Time-Varying Mirror Based on an Epsilon-Near-Zero Material,”** Physical Review Applied, Vol. 18, No. 05, 054067 (7 pages), November 21, 2022.
- J20. S. Kim, S. Lepeshov, A. Krasnok, and A. Alù, **“Beyond Bounds on Light Scattering with Complex Frequency Excitations,”** Physical Review Letters, Vol. 129, No. 20, 203601 (6 pages), November 8, 2022.
- J21. A. Alù, **“Tricking Light,”** Scientific American, Vol. 327, No. 5, pp. 42-51, November 2022 (published online on October 19, 2022), (*invited paper*). [*Press release*]
- J22. L. Stefanini, S. Yin, D. Ramaccia, A. Alù, A. Toscano, and F. Bilotti, **“Temporal Interfaces by Instantaneously Varying Boundary Conditions,”** Physical Review B, Vol. 106, No. 9, 094312 (6 pages), September 23, 2022.
- J23. A. Farhi, A. Mekawy, A. Alù, and D. Stone, **“Excitation of Absorbing Exceptional Points in the Time Domain,”** Physical Review A, Vol. 106, L031503 (6 pages), September 15, 2022. (*Letter*)
- J24. E. Galiffi, S. Yin, and A. Alù, **“Tapered Photonic Switching,”** Nanophotonics, Vol. 11, No. 16, pp. 3575-3581, August 17, 2022 (published online on July 20, 2022). [*Press release*]
- J25. M. Kang, Z. Zhang, T. Wu, X. Zhang, Q. Xu, A. Krasnok, J. Han, and A. Alù, **“Coherent Full Polarization Control Based on Bound States in the Continuum,”** Nature Communications, Vol. 13, No. 4536 (9 pages), August 4, 2022.
- J26. N. A. Aghamiri, G. Hu, A. Fali, Z. Zhang, J. Li, S. Balendhran, S. Walia, S. Sriram, J. H. Edgar, S. Ramanathan, A. Alù, and Y. Abate, **“Reconfigurable Hyperbolic Polaritonics with Correlated Metasurfaces,”** Nature Communications, Vol. 13, No. 4511 (9 pages), August 3, 2022.
- J27. M. Wang, G. Hu, S. Chand, M. Cotrufo, Y. Abate, K. Watanabe, T. Taniguchi, G. Grosso, C. W. Qiu, and A. Alù, **“Spin-Orbit-Locked Hyperbolic Polariton Vortices Carrying Reconfigurable Topological Charges,”** E-Light, Vol. 2, No. 12 (11 pages), July 18, 2022. [*Cover*, *Press release*]
- J28. J. Shin, Y. Ryu, M. A. Miri, S. B. Shim, H. Choi, A. Alù, J. Suh, and J. Cha, **“On-Chip Microwave Frequency Combs in a Superconducting Nanoelectromechanical Device,”** Nano Letters, Vol. 22, No. 13, pp. 5459-5465, July 13, 2022 (published online on June 16, 2022).
- J29. Y. W. Tsai, Y. T. Wang, E. Galiffi, A. Alù, and T. J. Yen, **“Surface-Wave Coupling in Double Floquet Sheets Supporting Phased Temporal Wood Anomalies,”** Nanophotonics, Vol. 11, No. 15, pp. 3509-3517, July 11, 2022.
- J30. F. B. Arango, F. Alpeggiani, D. Conteduca, A. Opheij, A. Chen, M. I. Abdelrahman, T. Krauss, A. Alù, F. Monticone, and L. Kuipers, **“Cloaked Near-Field Probe for Non-Invasive Near-Field Optical Microscopy,”** Optica, Vol. 9, No. 7, pp. 684-691, June 21, 2022.
- J31. R. E. Jacobsen, A. Krasnok, S. Arslanagić, A. V. Lavrinenko, and A. Alù, **“Boundary-Induced Embedded Eigenstate in a Single Resonator for Advanced Sensing,”** ACS Photonics, Vol. 9, No. 6, pp. 1936-1943, June 15, 2022 (published online on April 8, 2022). [*Cover*]
- J32. Z. L. Deng, F. J. LI, H. Li, X. Li, and A. Alù, **“Extreme Diffraction Control in Metagratings Leveraging Bound States in the Continuum and Exceptional Points,”** Laser and Photonics Reviews, Special Issue for the 15th Anniversary, Vol. 16, No. 6, 2100617 (6 pages), June 2022 (published online on March 6, 2022), (*invited paper*).
- J33. A. Nagulu, X. Ni, A. Kord, M. Tymchenko, S. Garikapati, A. Alù, and H. Krishnaswamy, **“Chip-Scale Floquet Topological Insulators for 5G Wireless Systems,”** Nature Electronics, Vol. 5, pp. 300-309, May 24, 2022 (published on May 2, 2022). [*Press release*, *IEEE Spectrum*, *Phys.org*]
- J34. C. L. Holloway, N. Prajapati, A. B. Artusio-Glimpse, S. Breweger, M. T. Simons, Y. Kasahara, A. Alù, and R. W. Ziolkowski, **“Rydberg Atom-Based Field Sensing Enhancement Using a Split-Ring Resonator,”** Applied Physics Letters, Vol. 120, 204001 (6 pages), May 20, 2022.
- J35. S. Yin, E. Galiffi, and A. Alù, **“Floquet Metamaterials,”** E-Light, Vol. 2, No. 8 (13 pages), May 19, 2022, (*invited paper*). [*Nanowerk*, *News and Views*, *Annual Award of E-Light*]

- J36. R. Duggan, S. Mann, and A. Alù, **“Limitations of Sensing at an Exceptional Point,”** ACS Photonics, Vol. 9, No. 5, pp. 1554–1566, May 18, 2022.
- J37. H. Li, S. Yin, and A. Alù, **“Nonreciprocity and Faraday Rotation at Time Interfaces,”** Physical Review Letters, Vol. 128, No. 17, 173901 (7 pages), April 29, 2022.
- J38. X. Shu, A. Li, G. Hu, J. Wang, A. Alù, and L. Chen, **“Fast Encirclement of an Exceptional Point for Highly Efficient and Compact Chiral Mode Converters,”** Nature Communications, Vol. 13, 2123 (6 pages), April 19, 2022.
- J39. G. Xu, Y. Yang, X. Zhou, H. Chen, A. Alù, and C. W. Qiu, **“Diffusive Topological Transport in Spatiotemporal Thermal Lattices,”** Nature Physics, Vol. 18, pp. 450-456, April 1, 2022 (published online on February 3, 2022).
- J40. S. Abdollahramezani, O. Hemmatyar, M. Taghinejad, H. Taghinejad, A. Krasnok, A. A. Eftekhar, C. Teichrib, S. Deshmukh, M. El-Sayed, E. Pop, M. Wuttig, A. Alù, W. Cai, and A. Adibi, **“Electrically Driven Reprogrammable Phase-Change Metasurface Reaching 80% Efficiency,”** Nature Communications, Vol. 13, No. 1696 (11 pages), March 30, 2022. [Phys.org]
- J41. S. Yin, and A. Alù, **“Efficient Phase Conjugation in a Space-Time Leaky Waveguide,”** ACS Photonics, Vol. 9, No. 3, pp. 979-984, March 16, 2022 (published online on February 10, 2022).
- J42. Y. Kawaguchi, A. Alù, and A. B. Khanikaev, **“Non-Reciprocal Parity-Time Symmetry Breaking Based on Magneto-Optical and Gain/Loss Double Ring Resonators,”** Optical Materials Express, Vol. 12, No. 4, pp. 1453-1460, March 16, 2022. [Spotlight]
- J43. R. Duggan, H. Moussa, D. L. Sounas, and A. Alù, **“Stability Bounds on Superluminal Propagation in Active Structures,”** Nature Communications, Vol. 13, No. 1115 (10 pages), March 2, 2022.
- J44. J. Soric, Y. Ra’di, D. Farfan, and A. Alù, **“Radio-Transparent Dipole Antenna Based on a Metasurface Cloak,”** Nature Communications, Vol. 13, No. 1114 (8 pages), March 2, 2022.
- J45. N. Nefedkin, M. Cotrufo, A. Krasnok, and A. Alù, **“Dark-State Induced Quantum Nonreciprocity,”** Advanced Quantum Technologies, Vol. 5, No. 3, 2100112 (17 pages), March 2022 (published online on January 28, 2022), (invited paper).
- J46. H. Goh, and A. Alù, **“Nonlocal Scatterer for Compact Wave-Based Analog Computing,”** Physical Review Letters, Vol. 128, No. 7, 073201 (6 pages), February 18, 2022. [Physics]
- J47. E. Galiffi, R. Tirole, S. Yin, H. Li, S. Vezzoli, P. A. Huidobro, M. G. Silveirinha, R. Sapienza, A. Alù, and J. B. Pendry, **“Photonics of Time-Varying Media,”** Advanced Photonics, Vol. 4, No. 1, 014002 (32 pages), February 14, 2022, (invited paper). [SPIE Newsroom]
- J48. Q. Xu, X. Su, X. Zhang, L. Dong, L. Liu, Y. Shi, Q. Wang, M. Kang, A. Alù, S. Zhang, J. Han, and W. Zhang, **“Mechanically Reprogrammable Pancharatnam-Berry Metasurface for Microwaves,”** Advanced Photonics, Vol. 4, No. 1, 016002 (11 pages), February 1, 2022. [Cover, Physics World, SPIE Newsroom]
- J49. Y. Radi, and A. Alù, **“Metagratings for Efficient Wavefront Manipulation,”** IEEE Photonics Journal, Vol. 14, No. 1, No. 2207513 (13 pages), February 1, 2022 (published online on December 17, 2021), (invited paper).
- J50. J. Li, Y. Li, P. C. Cao, M. Qi, X. Zheng, Y. G. Peng, B. Li, X. F. Zhu, A. Alù, H. Chen, and C. W. Qiu, **“Reciprocity of Thermal Diffusion in Time-Modulated Systems,”** Nature Communications, Vol. 13, No. 167 (8 pages), January 10, 2022.
- J51. Z. L. Deng, T. Shi, A. Krasnok, X. Li, and A. Alù, **“Observation of Localized Magnetic Plasmon Skyrmions,”** Nature Communications, Vol. 13, No. 8 (7 pages), January 10, 2022.
- J52. A. Alù, **“Space-Time Metasurfaces,”** in M. Piccardo, V. Ginis, A. Forbes, S. Mahler, A. A. Friesem, N. Davidson, H. Ren, A. H. Dorrah, F. Capasso, F. T. Dullo, B. S. Ahluwalia, A. Ambrosio, S. Gigan, N. Treps, M. Hiekkamäki, R. Fickler, M. Kues, D. Moss, R. Morandotti, J. Riemensberger, T. J. Kippenberg, J. Faist, G. Scalari, N. Picqué, T. W. Hänsch, G. Cerullo, C. Manzoni, L. A. Lugiato, M. Brambilla, L. Columbo, A. Gatti, F. Prati, A. Shiri, A. F. Abouraddy, A. Alù, E. Galiffi, J. B. Pendry, and

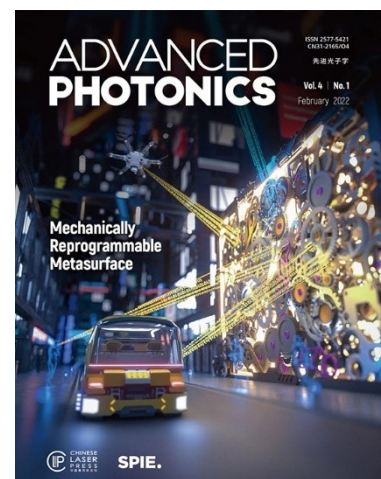

- P. A. Huidobro, "Roadmap on Multimode Light Shaping," *Journal of Optics*, Vol. 24, No. 1, 013001 (53 pages), December 16, 2021, (*invited paper*).
- J53. A. Krasnok, N. Nefedkin, and A. Alù, "**Parity-Time Symmetry and Exceptional Points**," *IEEE Antennas and Propagation Magazine*, Vol. 63, No. 3, pp. 110-121, December 6, 2021, (*invited paper*).
- J54. A. Kord, and A. Alù, "**Magnetless Circulators Based on Synthetic Angular-Momentum Bias**," *IEEE Antennas and Propagation Magazine*, Vol. 63, No. 6, pp. 51-61, December 6, 2021 (published online on January 1, 2021), (*invited paper*).
- J55. J. Zhang, B. Peng, S. Kim, F. Monifi, X. Jiang, Y. Li, P. Yu, L. Liu, Y. X. Liu, A. Alù, and L. Yang, "**Optomechanical Dissipative Solitons**," *Nature*, Vol. 600, pp. 75-80, December 1, 2021. [*News and Views*]
- J56. A. Hofstrand, M. Cotrufo, and A. Alù, "**Nonreciprocal Pulse Shaping and Chaotic Modulation with Asymmetric Noninstantaneous Nonlinear Resonators**," *Physical Review A*, Vol. 104, No. 5, 053529 (8 pages), November 29, 2021.
- J57. M. Pascale, S. A. Mann, C. Forestiere, and A. Alù, "**Bandwidth of Singular Plasmonic Resonators in Relation to the Chu Limit**," *ACS Photonics*, Vol. 8, No. 11, pp. 3249-3260, November 17, 2021 (published online on October 25, 2021).
- J58. Z. X. Chen, Y. G. Peng, H. X. Li, J. J. Liu, Y. J. Ding, B. Liang, X. F. Zhu, Y. Q. Lu, J. C. Cheng, and A. Alù, "**Efficient Nonreciprocal Mode Transitions in Spatiotemporally Modulated Acoustic Metamaterials**," *Science Advances*, Vol. 7, No. 45, eabj1198 (8 pages), November 3, 2021.
- J59. S. Ramezani, A. Bogdanov, A. Alù, and Y. Radi, "**Generalization of Exceptional Point Conditions in Perturbed Coupled Resonators**," *Physical Review B*, Vol. 104, No. 20, 205405 (8 pages), November 3, 2021.
- J60. Z. Xiao, and A. Alù, "**Tailoring Exceptional Points in a Hybrid PT-Symmetric and Anti-PT-Symmetric Scattering System**," *Nanophotonics*, Special Issue in Honor of Mark Stockman, Vol. 10, No. 14, pp. 3723-3733, October 28, 2021 (published online on July 26, 2021), (*invited paper*).
- J61. C. Valagiannopoulos, A. Sarsen, and A. Alù, "**Angular Memory of Photonic Metasurfaces**," *IEEE Transactions on Antennas and Propagation*, Vol. 69, No. 11, pp. 7720-7728, October 28, 2021 (published online on June 2, 2021).
- J62. H. Li, S. Yin, E. Galiffi, and A. Alù, "**Temporal Parity-Time Symmetry for Extreme Energy Transformations**," *Physical Review Letters*, Vol. 127, 153903 (7 pages), October 7, 2021.
- J63. S. A. Mann, and A. Alù, "**Broadband Topological Slow Light through Brillouin-Zone Winding**," *Physical Review Letters*, Vol. 127, No. 12, 123601 (6 pages), September 13, 2021.
- J64. M. Cotrufo, S. A. Mann, H. Moussa, and A. Alù, "**Nonlinearity-Induced Nonreciprocity – Part II**," *IEEE Transactions on Microwave Theory and Techniques*, Vol. 69, No. 8, pp. 3584-3597, August 7, 2021 (published online on June 2, 2021), (*invited paper*).
- J65. M. Cotrufo, S. A. Mann, H. Moussa, and A. Alù, "**Nonlinearity-Induced Nonreciprocity – Part I**," *IEEE Transactions on Microwave Theory and Techniques*, Vol. 69, No. 8, pp. 3569-3583, August 7, 2021 (published online on June 3, 2021), (*invited paper*).
- J66. C. Rasmussen, and A. Alù, "**Non-Foster Acoustic Radiation From an Active Piezoelectric Transducer**," *Proceedings of the National Academy of Sciences*, Vol. 118, No. 30, e2024984118 (7 pages), July 27, 2021 (published online on July 19, 2021).
- J67. Y. Mazor, M. Cotrufo, and A. Alù, "**Unitary Excitation Transfer Between Coupled Cavities Using Temporal Switching**," *Physical Review Letters*, Vol. 127, 013902 (6 pages), July 2, 2021.
- J68. H. Li, A. Mekawy, and A. Alù, "**Gain-Free Parity-Time Symmetry for Evanescent Fields**," *Physical Review Letters*, Vol. 127, 014301 (7 pages), July 1, 2021.
- J69. Z. Sakotic, A. Krasnok, A. Alù, and N. Jankovic, "**Topological Scattering Singularities and Embedded Eigenstates for Polarization Control and Sensing Applications**," *Photonics Research*, Vol. 9, No. 7, pp. 1310-1323, July 2021 (published online on June 28, 2021).
- J70. S. Guddala, Y. Kawaguchi, F. Komissarenko, S. Kiriushechkina, A. Vakulenko, K. Chen, A. Alù, V. M. Menon, and A. B. Khanikaev, "**All-Optical Nonreciprocity Due to Valley Polarization Pumping in Transition Metal Dichalcogenides**," *Nature Communications*, Vol. 12, 3746 (9 pages), June 18, 2021.

- J71. Y. Kawaguchi, M. Li, K. Chen, V. Menon, A. Alù, and A. B. Khanikaev, **“Optical Isolator Based on Chiral Light-Matter Interactions in a Ring Resonator Integrating a Dichroic Magneto-Optical Material,”** in Applied Physics Letters, Special Topic Collection on Metastructures: From Physics to Application, Vol. 118, No. 24, 241104 (5 pages), June 15, 2021, (*invited paper*).
- J72. C. Rasmussen, L. Quan, and A. Alù, **“Acoustic Nonreciprocity,”** Journal of Applied Physics, Special Issue on Acoustics 2021, Vol. 129, 210903 (12 pages), June 2, 2021, (*invited paper*). [*Editor’s Pick, AIP SciLight*]
- J73. N. Nefedkin, A. Alù, and A. Krasnok, **“Quantum Embedded Superstates,”** Advanced Quantum Technologies, Vol. 4, No. 6, 2000121 (11 pages), June 2021 (published online on May 5, 2021).
- J74. A. Mekawy, H. Li, Y. Ra’di, and A. Alù, **“Parametric Enhancement of Radiation from Electrically Small Antennas,”** Physical Review Applied, Vol. 15, 054063 (11 pages), May 27, 2021.
- J75. J. Fang, M. Wang, K. Yao, T. Zhang, A. Krasnok, T. Jiang, J. Choi, E. Kahn, B. A. Korgel, M. Terrones, X. Li, A. Alù, and Y. Zheng, **“Directional Modulation of Exciton Emission Using Dielectric Nanospheres,”** Advanced Materials, Vol. 33, No. 20, 2007236 (8 pages), May 20, 2021 (published online on April 9, 2021). [*Cover*]
- J76. L. Quan, S. Yves, Y. Peng, H. Esfahlani, and A. Alù, **“Odd Willis Coupling Induced by Broken Time-Reversal Symmetry,”** Nature Communications, Vol. 12, 2615 (9 pages), May 10, 2021.
- J77. X. Ni, and A. Alù, **“Higher-Order Topoelectrical Semimetal Realized via Synthetic Gauge Fields,”** APL Photonics, Special Collection on Synthetic Gauge Field Photonics, Vol. 6, No. 5, 050802 (9 pages), May 3, 2021, (*invited paper*).
- J78. S. A. Mann, N. Nookala, S. C. Johnson, M. Cotrufo, A. Mekawy, J. F. Klem, I. Brener, M. B. Raschke, A. Alù, and M. A. Belkin, **“Ultrafast Optical Switching and Power Limiting in Intersubband Polaritonic Metasurfaces,”** Optica, Vol. 8, No. 5, pp. 606-613, April 29, 2021.
- J79. A. Nagulu, A. Mekawy, M. Tymchenko, D. Sounas, A. Alù, and H. Krishnaswamy, **“Ultra-Wideband Switched-Capacitor Delays and Circulators – Theory and Implementation,”** IEEE Journal of Solid State Circuits, Vol. 56, No. 5, pp. 1412-1424, May 2021 (published online on February 12, 2021), (*invited paper*).
- J80. D. Chachayma-Farfan, Y. Ra’di, and A. Alù, **“Dual-Layer Radio-Transparent Dielectric Core Metasurface Antenna,”** IEEE Open Journal of Antennas and Propagation, Special Issue on Direct and Inverse Electromagnetic Scattering Methods, Vol. 2, pp. 585-590, April 26, 2021, (*invited paper*).
- J81. A. Mekawy, D. L. Sounas, and A. Alù, **“Free-Space Nonreciprocal Transmission Based on Nonlinear Coupled Fano Metasurfaces,”** Photonics, Special Issue on Advances in Complex Media Electromagnetics, Vol. 8, No. 5, 139 (24 pages), April 23, 2021, (*invited paper*).
- J82. R. Duggan, J. del Pino, E. Verhagen, D. Sounas, and A. Alù, **“Nonlinearity-Driven Broken Degeneracy and Nonreciprocity,”** FERMAT, Vol. 44, 4 (2 pages), April 4, 2021.
- J83. M. Coppolaro, M. Moccia, G. Castaldi, A. Alù, and V. Galdi, **“Surface-Wave Propagation on Non-Hermitian Metasurfaces with Extreme Anisotropy,”** IEEE Transactions on Microwave Theory and Techniques, Special Issue on Metamaterials, Vol. 69, No. 4, pp. 2060-2071, April 1, 2021 (published online on March 2, 2021), (*invited paper*).
- J84. S. A. Mann, A. Mekawy, and A. Alù, **“Broadband Field Localization, Density of States, and Nonlinearity Enhancement in Nonreciprocal and Topological Hotspots,”** Physical Review Applied, Vol. 15, No. 3, 034064 (18 pages), March 22, 2021. [*Editor’s Suggestion*]
- J85. D. Ramaccia, A. Alù, A. Toscano, and F. Bilotti, **“Temporal Multilayer Structures for Designing Higher-Order Transfer Functions Using Time-Varying Metamaterials,”** Applied Physics Letters, Special Topic Collection on Metastructures: From Physics to Application, Vol. 118, No. 10, 101901 (7 pages), March 8, 2021, (*invited paper*).

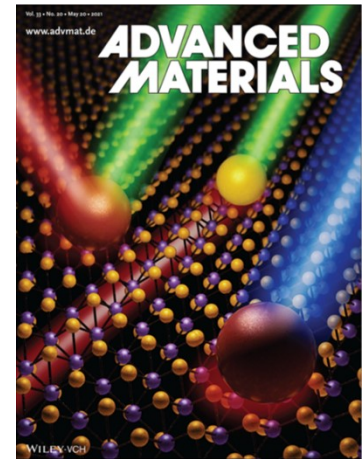

- J86. A. Bergman, R. Duggan, K. Sharma, M. Tur, A. Zadok, and A. Alù, **“Observation of Anti-Parity-Time-Symmetry, Phase Transitions and Exceptional Points in an Optical Fiber,”** Nature Communications, Vol. 12, No. 486 (9 pages), January 20, 2021.
- J87. M. Tymchenko, A. Nagulu, H. Krishnaswamy, and A. Alù, **“Universal Frequency-Domain Analysis of N-Path Networks,”** IEEE Transactions on Circuits and Systems, Vol. 68, No. 2, pp. 569-580, January 17, 2021 (published online on December 7, 2020). [*Issue Highlight*]
- J88. A. Mekawy, and A. Alù, **“Giant Midinfrared Nonlinearity Based on Multiple Quantum Well Polaritonic Metasurfaces,”** Nanophotonics, Special Issue Frontiers of Optics and Photonics, Vol. 10, No. 1, pp. 667-678, January 1, 2021 (published online on September 14, 2020), (*invited paper*).
- J89. H. Li, and A. Alù, **“Temporal Switching to Extend the Bandwidth of Thin Absorbers,”** Optica, Vol. 8, No. 1, pp. 24-29, December 24, 2020.
- J90. S. Dong, G. Hu, Q. Wang, Y. Jia, Q. Zhang, G. Cao, J. Wang, S. Chen, D. Fan, W. Jiang, Y. Li, A. Alù, and C. W. Qiu, **“Loss-Assisted Metasurface at an Exceptional Point,”** ACS Photonics, Vol. 7, No. 12, pp. 3321-3327, December 16, 2020 (published online on December 7, 2020).
- J91. K. Y. Yang, J. Skarda, A. Dutt, G. H. Ahn, M. Sawaby, D. Vercruyse, A. Arbabian, S. Fan, J. Vučković, M. Cotrufo, and A. Alù, **“Nonreciprocal Devices in Silicon Photonics,”** Optics and Photonics News, Special Issue Year in Optics 2020, Vol. 31, No. 12, p. 38, December 1, 2020 (published online November 23, 2020).
- J92. A. Li, J. Dong, J. Wang, Z. Cheng, J. S. Ho, D. Zhang, J. Wen, X. L. Zhang, C. T. Chan, A. Alù, C. W. Qiu, and L. Chen, **“Hamiltonian Hopping for Efficient Chiral Mode Switching in Encircling Exceptional Points,”** Physical Review Letters, Vol. 125, No. 18, 187403 (6 pages), October 30, 2020.
- J93. A. Alù, **“Metamaterials for Next-Generation Communication Systems,”** ComSoc Technology News, October 19, 2020, (*invited paper*).
- J94. A. Kord, D. Sounas, and A. Alù, **“Magnet-Free Microwave Nonreciprocity,”** Proceedings of IEEE, Vol. 108, No. 10, pp. 1682-1683, October 1, 2020 (published online on September 28, 2020), (*invited paper*). [Cover]
- J95. A. Alù, **“Magnet-Free Nonreciprocity,”** Proceedings of IEEE, Vol. 108, No. 10, pp. 1682-1683, October 1, 2020 (published online on September 28, 2020), (*invited paper*). [Cover]
- J96. R. Duggan, S. A. Mann, and A. Alù, **“Non-Reciprocal Photonic Topological Order Driven by Uniform Optical Pumping,”** Physical Review B, Rapid Communications, Vol. 102, No. 10, 100303(R), September 25, 2020.
- J97. E. Galiffi, Y. T. Wang, Z. Lim, J. B. Pendry, A. Alù, and P. A. Huidobro, **“Wood Anomalies and Surface-Wave Excitation with a Time Grating,”** Physical Review Letters, Vol. 125, No. 12, 127403 (6 pages), September 17, 2020.
- J98. H. Li, H. Moussa, D. Sounas, and A. Alù, **“Parity-Time Symmetry Based on Time Modulation,”** Physical Review Applied, Vol. 14, No. 3, 031002 (6 pages), September 11, 2020. [Editor’s Pick, Letter]
- J99. Z. Zhang, M. Kang, X. Zhang, X. Feng, Y. Xu, X. Chen, H. Zhang, Q. Xu, Z. Tian, W. Zhang, A. Krasnok, J. Han, and A. Alù, **“Coherent Perfect Diffraction in Controlled Metagratings,”** Advanced Materials, Vol. 32, No. 36, 2002341 (6 pages), September 10, 2020 (published online on July 23, 2020). [Cover, SUM]
- J100. H. Nassar, B. Yousefzadeh, R. Fleury, M. Ruzzene, A. Alù, C. Daraio, A. N. Norris, G. Huang, and M. R. Haberman, **“Nonreciprocity in Acoustic and Elastic Materials,”** Nature Reviews Materials, Vol. 5, pp. 667-685, September 1, 2020 (published online on July 6, 2020), (*invited paper*).
- J101. S. A. Mann, D. L. Sounas, and A. Alù, **“Nonreciprocal Cavities and the Time-Bandwidth Limit: Reply,”** Optica, Vol. 7, No. 9, pp. 1102-1107, August 28, 2020.

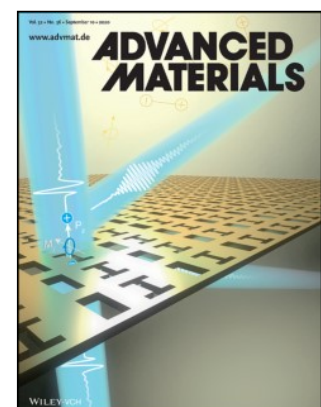
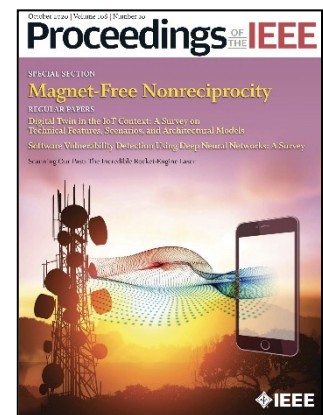

- J102. M. Moccia, G. Castaldi, A. Alù, and V. Galdi, **“Line Waves in Non-Hermitian Metasurfaces,”** ACS Photonics, Vol. 7, No. 8, pp. 2064-2072, August 19, 2020 (published online on June 30, 2020).
- J103. A. Darabi, X. Ni, M. Leamy, and A. Alù, **“Reconfigurable Floquet Elastodynamic Topological Insulators Based on Synthetic Angular Momentum Bias,”** Science Advances, Vol. 6, No. 19, eaba8656 (5 pages), July 17, 2020. [Press release, Physics World, UPI, SUM]
- J104. Y. Mazor, and A. Alù, **“Routing Optical Spin and Pseudospin with Metasurfaces,”** Physical Review Applied, Vol. 14, No. 1, 014029 (11 pages), July 10, 2020.
- J105. S. Abdollahramezani, O. Hemmatyar, H. Taghinejad, A. Krasnok, Y. Kiarashinejad, M. Zandehshahvar, A. Alù, and A. Adibi, **“Tunable Nanophotonics Based on Chalcogenide Phase-Change Materials,”** Nanophotonics, Vol. 9, No. 5, pp. 1189–1241, June 29, 2020, (*invited paper*).
- J106. Y. K. Chiang, S. Oberst, A. Melnikov, L. Quan, S. Marburg, A. Alù, and D. A. Powell, **“Reconfigurable Acoustic Metagrating for High-Efficiency Anomalous Reflection,”** Physical Review Applied, Vol. 13, No. 6, 064067 (8 pages), June 29, 2020.
- J107. Y. J. Zhang, P. Li, V. Galdi, M. S. Tong, and A. Alù, **“Manipulating the Scattering Pattern with Non-Hermitian Particle Arrays,”** Optics Express, Vol. 28, No. 13, pp. 19492-19507, June 17, 2020.
- J108. Y. Radi, A. Krasnok and A. Alù, **“Virtual Critical Coupling,”** ACS Photonics, Vol. 7, No. 6, pp. 1468-1475, June 17, 2020 (published online on May 7, 2020). [Cover]
- J109. Z. Xiao, D. L. Sounas, M. Tymchenko, A. Nagulu, M. Tymchenko, T. Dinc, H. Krishnaswamy, and A. Alù, **“Role of Synchronization in Magnetless Nonreciprocal Devices Based on Commutated Transmission Lines,”** Physical Review Applied, Vol. 13, No. 6, 064033 (29 pages), June 15, 2020.
- J110. X. Ni, Z. Xiao, A. B. Khanikaev, and A. Alù, **“Robust Multiplexing with Topoelectrical Higher-Order Chern Insulators,”** Physical Review Applied, Vol. 13, No. 6, 064031 (8 pages), June 12, 2020.
- J111. K. Y. Yang, J. Skarda, M. Cotrufo, A. Dutt, G. H. Ahn, M. Sawaby, D. Vercruyse, A. Arbabian, S. Fan, A. Alù, and J. Vuckovic, **“Inverse-Designed Non-Reciprocal Pulse Router for Chip-Based LiDAR,”** Nature Photonics, Vol. 14, No. 6, pp. 369-374, May 29, 2020, published online on March 23, 2020. [News and Views, Press release, Ars Technica]
- J112. H. Li, A. Mekawy, A. Krasnok, and A. Alù, **“Virtual Parity-Time Symmetry,”** Physical Review Letters, Vol. 124, No. 19, 193901 (7 pages), May 14, 2020.
- J113. A. Alù, J. Chennupati, and H. V. Demir **“Active Nanophotonics,”** Proceedings of IEEE, Vol. 108, No. 5, pp. 625-627, April 28, 2020, (*invited paper*).
- J114. A. Krasnok, and A. Alù, **“Active Nanophotonics,”** Proceedings of IEEE, Vol. 108, No. 5, pp. 628-654, April 20, 2020, (*invited paper*).
- J115. Y. Radi, and A. Alù, **“Nonreciprocal Wavefront Manipulation in Synthetically Moving Metagratings,”** Photonics, Special Issue for Metamaterials 2019, Vol. 7, No. 2, 28 (7 pages), April 18, 2020, (*invited paper*). [Cover]
- J116. X. Wang, A. Diaz-Rubio, H. Li, S. A. Tretyakov, and A. Alù, **“Theory and Design of Multifunctional Space-Time Metasurfaces,”** Physical Review Applied, Vol. 13, No. 4, 044040 (15 pages), April 15, 2020.
- J117. L. J. Fernández-Alcázar, H. Li, F. Ellis, A. Alù, and T. Kottos, **“Robust Scattered Fields from Adiabatically Driven Targets around Exceptional Points,”** Physical Review Letters, Vol. 124, No. 13, 133905 (6 pages), April 2, 2020.
- J118. Y. Mazor, and A. Alù, **“One-Way Hyperbolic Metasurfaces Based on Synthetic Motion,”** IEEE Transactions on Antennas and Propagation, Special Issue on Recent Advances in Metamaterials and Metasurfaces, Vol. 68, No. 3, pp. 1739-1747, March 1, 2020, (*invited paper*).
- J119. M. Moccia, G. Castaldi, A. Alù, and V. Galdi, **“Harnessing Spectral Singularities in Non-Hermitian Cylindrical Structures,”** IEEE Transactions on Antennas and Propagation, Special Issue on Recent

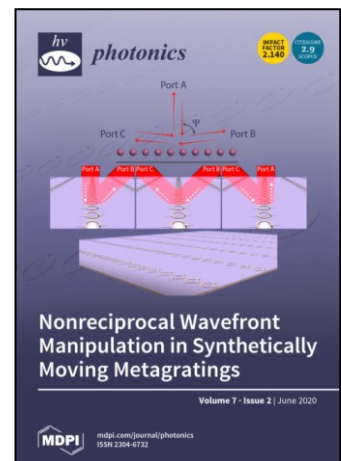
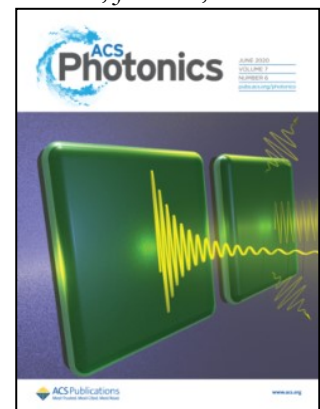

- Advances in Metamaterials and Metasurfaces, Vol. 68, No. 3, pp. 1704-1716, March 1, 2020, (*invited paper*).
- J120. D. Ramaccia, D. L. Sounas, A. Alù, A. Toscano, and F. Bilotti, **“Phase-Induced Frequency Conversion and Doppler Effect with Time-Modulated Metasurfaces,”** IEEE Transactions on Antennas and Propagation, Special Issue on Recent Advances in Metamaterials and Metasurfaces, Vol. 68, No. 3, pp. 1607-1617, March 3, 2020.
- J121. A. Casolaro, A. Toscano, A. Alù, and F. Bilotti, **“Dynamic Beam Steering with Reconfigurable Metagratings,”** IEEE Transactions on Antennas and Propagation, Special Issue on Recent Advances in Metamaterials and Metasurfaces, Vol. 68, No. 3, pp. 1542-1552, March 3, 2020, (*invited paper*).
- J122. G. D’Aguanno, Y. Hadad, D. A. Smirnova, X. Ni, A. Khanikaev, and A. Alù, **“Nonlinear Topological Transitions Over a Metasurface,”** Physical Review B, Vol. 100, No. 21, 214310 (8 pages), December 19, 2019. [PRB Kaleidoscope]
- J123. A. Krasnok, D. Baranov, H. Li, M. A. Miri, F. Monticone, and A. Alù, **“Anomalies in Light Scattering,”** Advances in Optics and Photonics, Vol. 11, No. 4, pp. 892-951, December 3, 2019, (*invited paper*).
- J124. Y. Yu, G. Michetti, M. Pirro, A. Kord, D. L. Sounas, Z. Xiao, C. Cassella, A. Alù, and M. Rinaldi, **“Radio Frequency Magnet-Free Circulators Based on Spatiotemporal Modulation of Surface Acoustic Wave Filters,”** IEEE Transactions on Microwave Theory and Techniques, Vol. 67, No. 12, pp. 4773-4782, December 1, 2019.
- J125. Y. Yu, G. Michetti, A. Kord, M. Pirro, D. L. Sounas, Z. Xiao, C. Cassella, A. Alù, and M. Rinaldi, **“Highly-Linear Magnet-Free Microelectromechanical Circulators,”** Journal of Micro Electro-Mechanical Systems, Vol. 28, No. 6, pp. 933-940, December 1, 2019.
- J126. Z. Xiao, Y. Radi, S. Tretjakov, and A. Alù, **“Microwave Tunneling and Robust Information Transfer Based on Parity-Time-Symmetric Absorber-Emitter Pairs,”** Research, Vol. 2019, No. 7108494 (10 pages), November 28, 2019.
- J127. Z. Xiao, H. Li, T. Kottos, and A. Alù, **“Enhanced Sensing and Nondegraded Thermal Noise Performance Based on PT-Symmetric Electronic Circuits with a Sixth-Order Exceptional Point,”** Physical Review Letters, Vol. 123, No. 21, 213901 (6 pages), November 18, 2019.
- J128. C. Cassella, G. Michetti, M. Pirro, Y. Yu, A. Kord, D. Sounas, A. Alù, and M. Rinaldi, **“Radio Frequency Angular Momentum Biased Quasi-LTI Nonreciprocal Acoustic Filters,”** IEEE Transactions on Ultrasonics, Ferroelectrics and Frequency Control, Vol. 66, No. 11, pp. 1814-1825, November 1, 2019.
- J129. H. Li, A. Mekawy, and A. Alù, **“Beyond Chu’s Limit with Floquet Impedance Matching,”** Physical Review Letters, Vol. 123, No. 16, 164102 (6 pages), October 16, 2019.
- J130. F. Monticone, D. L. Sounas, A. Krasnok, and A. Alù, **“Can a Nonradiating Mode Be Externally Excited? Nonscattering States versus Embedded Eigenstates,”** ACS Photonics, Vol. 6, No. 12, pp. 3108-3114, October 15, 2019. [Cover]
- J131. R. Duggan, D. L. Sounas, and A. Alù, **“Optically Driven Effective Faraday Effect in Instantaneous Nonlinear Media,”** Optica, Vol. 6, No. 9, pp. 1152-1157, August 30, 2019.
- J132. G. Trainiti*, Y. Radi*, M. Ruzzene, and A. Alù, **“Coherent Virtual Absorption of Elastodynamic Waves,”** Science Advances, Vol. 5, No. 8, 3255 (7 pages), August 30, 2019. [Press release, Featured in Newweek]
- J133. A. Kord, H. Krishnaswamy, and A. Alù, **“Magnetless Circulators with Harmonic Rejection Based on N-Way Cyclic-Symmetric Time-Varying Networks,”** Physical Review Applied, Vol. 12, No. 2, 024046 (14 pages), August 22, 2019.
- J134. L. Quan, D. L. Sounas, and A. Alù, **“Non-Reciprocal Willis Coupling in Zero-Index Moving Media,”** Physical Review Letters, Vol. 123, No. 6, 064301 (6 pages), August 9, 2019.

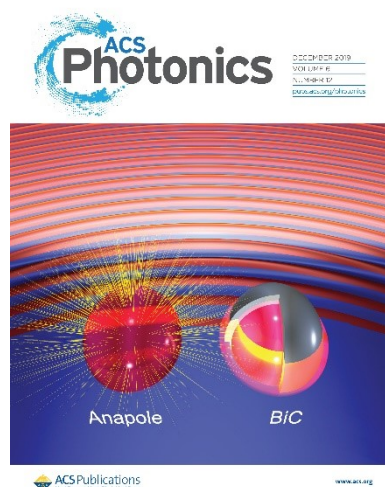

- J135. M. Tymchenko, D. L. Sounas, A. Nagulu, H. Krishnaswamy, and A. Alù, **“Quasielectrostatic Wave Propagation Beyond the Delay-Bandwidth Limit in Switched Networks,”** *Physical Review X*, Vol. 9, No. 3, 031015 (16 pages), July 31, 2019.
- J136. C. P. Wiederhold, D. L. Sounas, and A. Alù, **“Nonreciprocal Acoustic Propagation and Leaky-Wave Radiation in a Waveguide with Flow,”** *Journal of the Acoustical Society of America*, Special Issue on Non-reciprocal and Topological Wave Phenomena in Acoustics, Vol. 146, No. 1, pp. 802-809, July 31, 2019.
- J137. M. Li, X. Ni, M. Weiner, A. Alù, and A. B. Khanikaev, **“Topological Phases and Nonreciprocal Edge States in Non-Hermitian Floquet Insulators,”** *Physical Review B*, Vol. 100, No. 4, 045423 (9 pages), July 29, 2019.
- J138. S. A. Mann, D. L. Sounas, and A. Alù, **“Broadband Delay Lines and Nonreciprocal Resonances in Unidirectional Waveguides,”** *Physical Review B*, Rapid Communications, Vol. 100, No. 2, 020303R (5 pages), July 24, 2019.
- J139. A. Melnikov, Y. K. Chang, L. Quan, S. Oberst, A. Alù, S. Marburg, and D. Powell, **“Acoustic Meta-Atom with Experimentally Verified Maximum Willis Coupling,”** *Nature Communications*, Vol. 10, No. 3148 (7 pages), July 17, 2019.
- J140. M. A. Miri, M. Cotrufo, and A. Alù, **“Anomalous Optical Forces in PT-Symmetric Waveguides,”** *Optics Letters*, Vol. 44, No. 14, pp. 3558-3561, July 12, 2019.
- J141. R. Duggan, J. del Pino, E. Verhagen, and A. Alù, **“Optomechanically Induced Birefringence and Optomechanically Induced Faraday Effect,”** *Physical Review Letters*, Vol. 123, No. 2, 023602 (7 pages), July 9, 2019.
- J142. A. Alù, **“Active and Reconfigurable Metasurfaces,”** *Journal of Optics*, in O. Quevedo-Teruel, H. Chen, A. Díaz-Rubio, G. Gok, A. Grbic, G. Minatti, E. Martini, S. Maci, G. V. Eleftheriades, M. Chen, N. I. Zheludev, N. Papasimakis, S. Choudhury, Z. A. Kudyshev, S. Saha, H. Reddy, A. Boltasseva, V. M. Shalaev, A. V. Kildishev, D. Sievenpiper, C. Caloz, A. Alù, Q. He, L. Zhou, G. Valerio, E. Rajo-Iglesias, Z. Sipus, F. Mesa, R. Rodríguez-Berral, F. Medina, V. Asadchy, S. Tretyakov, and C. Craeye, Topical Review, “Roadmap on Metasurfaces,” Vol. 21, 073002 (44 pages), July 1, 2019, (*invited paper*).
- J143. A. Kord, M. Tymchenko, D. L. Sounas, H. Krishnaswamy, and A. Alù, **“CMOS Integrated Magnetless Circulators Based on Spatiotemporal Modulation Angular-Momentum Biasing,”** *IEEE Transactions on Microwave Theory and Techniques*, Vol. 67, No. 7, pp. 2649-2662, July 1, 2019.
- J144. M. Cotrufo, and A. Alù, **“Excitation of Single-Photon Embedded Eigenstates in Coupled Cavity-Atom Systems,”** *Optica*, Vol. 6, No. 6, pp. 799-804, June 10, 2019.
- J145. S. Leshov, A. Krasnok, and A. Alù, **“Nonradiative-to-Superscattering Switch with Phase-Change Materials,”** *ACS Photonics*, Vol. 6, No. 8, pp. 2126-2132, July 11, 2019, online at: <https://arxiv.org/abs/1904.11442>. [Journal cover]
- J146. X. Ni, K. Chen, M. Weiner, D. J. Apigo, C. Prodan, A. Alù, E. Prodan, and A. B. Khanikaev, **“Observation of the Hofstadter Butterfly and Topological Edge States in Reconfigurable Quasi-Periodic Acoustic Crystals,”** *Communication Physics*, Vol. 2, No. 55 (7 pages), June 6, 2019.
- J147. A. Mock, D. L. Sounas, and A. Alù, **“Magnet-Free Circulator Based on Spatiotemporal Modulation of Photonic Crystal Defect Cavities,”** *ACS Photonics*, Vol. 6, No. 8, pp. 2056-2066, May 28, 2019. [Journal Cover]

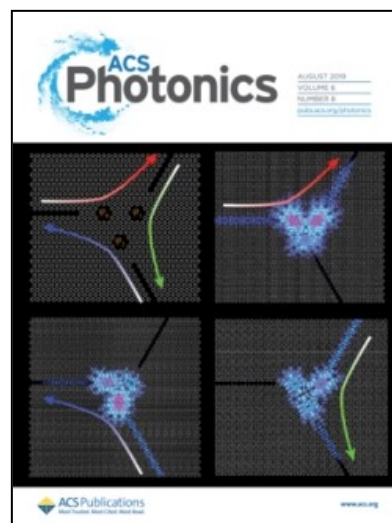
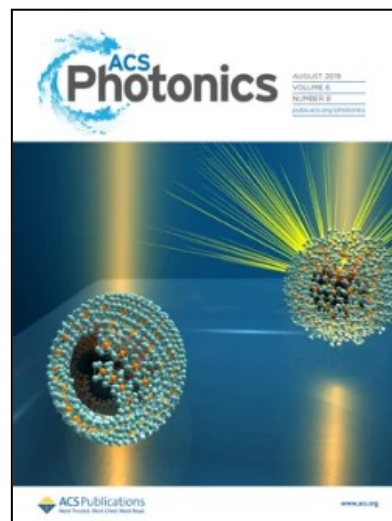

- J148. G. D'Aguzzo, D. L. Sounas, H. M. Sayed, and A. Alù, **"Nonlinearity-Based Circulator,"** Applied Physics Letters, Vol. 114, No. 18, 181102 (4 pages), May 7, 2019.
- J149. Y. Li, M. A. Miri, A. Alù, and C. W. Qiu, **"Anti-Parity-Time Symmetry in Diffusive Systems,"** Science, Vol. 364, No. 6436, pp. 170-173, April 12, 2019.
- J150. J. Zhao, X. Yang, J. Y. Dai, Q. Cheng, X. Li, N. H. Qi, J. C. Ke, G. D. Bai, S. Liu, S. Jin, A. Alù, and T. J. Cui, **"Programmable Time-Domain Digital-Coding Metasurface for Non-Linear Harmonic Manipulation and New Wireless Communication Systems,"** National Science Review, Vol. 6, No. 2, pp. 231-238, March 1, 2019.
- J151. S. A. Mann, D. L. Sounas, and A. Alù, **"Breaking Lorentz Reciprocity to Overcome the Time-Bandwidth Limit in Physics and Engineering,"** Optica, Vol. 6, No. 1, pp. 104-110, January 17, 2019.
- J152. Y. Mazor, and A. Alù, **"Non-Reciprocal Hyperbolic Propagation over Moving Metasurfaces,"** Physical Review B, Vol. 99, No. 4, 045407 (5 pages), January 8, 2019.
- J153. M. A. Miri, and A. Alù, **"Exceptional Points in Optics and Photonics,"** Science, Vol. 363, No. 6422, p. 42 (11 pages), January 4, 2019.
- J154. A. Kord, D. L. Sounas, Z. Xiao, and A. Alù, **"Broadband Cyclic-Symmetric Magnetless Circulators and Theoretical Bounds on their Bandwidth,"** IEEE Transactions on Microwave Theory and Techniques, Special Issue for the 2018 International Microwave Symposium, Vol. 66, No. 12, pp. 5472-5481, December 12, 2018.
- J155. A. Kord, D. L. Sounas, and A. Alù, **"Active Microwave Cloaking Using Parity-Time Symmetric Satellites,"** Physical Review Applied, Vol. 10, No. 5, 054040 (15 pages), November 19, 2018.
- J156. A. Nagulu, T. Dinc, Z. Xiao, M. Tymchenko, D. L. Sounas, A. Alù, and H. Krishnaswamy, **"Nonreciprocal Components Based on Switched Transmission Lines,"** IEEE Transactions on Microwave Theory and Techniques, Vol. 66, No. 11, pp. 4706-4725, November 1, 2018.
- J157. C. Caloz, and A. Alù, **"Guest Editorial: Special Cluster on Magnetless Nonreciprocity in Electromagnetics,"** IEEE Antennas and Wireless Propagation Letters, Vol. 17, No. 11, pp. 1931-1937, October 29, 2018.
- J158. D. Correas-Serrano, A. Alù, and J. S. Gomez-Diaz, **"Magnetic-Free Non-Reciprocal Photonic Platform Based on Time-Modulated Graphene Capacitors,"** Physical Review B, Vol. 98, No. 16, 165428 (10 pages), October 19, 2018.
- J159. C. Caloz, A. Alù, S. Tretyakov, D. L. Sounas, K. Achouri, and Z. L. Deck-Leger, **"Electromagnetic Nonreciprocity,"** Physical Review Applied, Vol. 10, No. 4, 047001 (26 pages), October 1, 2018.
- J160. D. Ramaccia, D. L. Sounas, A. Alù, F. Bilotti, and A. Toscano, **"Non-Reciprocity in Antenna Radiation Induced by Space-Time Varying Metamaterial Cloaks,"** IEEE Antennas and Wireless Propagation Letters, Special Cluster on Magnet-Less Nonreciprocity in Electromagnetics, Vol. 17, No. 11, pp. 1968-1972, September 17, 2018.
- J161. Z. Li, Q. Dai, M. Q. Mehmood, G. Hu, B. Lukyanchuk, J. Tao, C. Hao, I. Kim, H. Jeong, G. Zheng, S. Yu, A. Alù, J. Rho, and C. W. Qiu, **"Full-Space Cloud of Random Points with a Scrambling Metasurface,"** Light: Science & Applications, Vol. 7, No. 63 (8 pages), September 12, 2018.
- J162. D. L. Sounas, N. A. Estep, A. Kord, and A. Alù, **"Angular-Momentum Biased Circulators and Their Power Consumption,"** IEEE Antennas and Wireless Propagation Letters, Special Cluster on Magnet-Less Nonreciprocity in Electromagnetics, Vol. 17, No. 11, pp. 1963-1967, September 4, 2018, (*invited paper*).
- J163. A. Mock, D. L. Sounas, and A. Alù, **"Tunable Orbital Angular Momentum Radiation from Angular Momentum-Biased Microcavities,"** Physical Review Letters, Vol. 121, No. 10, 103901 (6 pages), September 4, 2018.
- J164. D. L. Sounas, and A. Alù, **"Non-Reciprocity Based on Nonlinear Resonances,"** IEEE Antennas and Wireless Propagation Letters, Special Cluster on Magnet-Less Nonreciprocity in Electromagnetics, Vol. 17, No. 11, pp. 1958-1962, August 24, 2018, (*invited paper*).
- J165. Safavi-Naeini, Amir H., Dries Van Thourhout, Roel Baets, and Raphaël Van Laer. **"Controlling phonons and photons at the wavelength scale: integrated photonics meets integrated phononics."** Optica 6, no. 2 (2019): 213-232.

- J166. Datta, I., Chae, S.H., Bhatt, G.R. et al. **Low-loss composite photonic platform based on 2D semiconductor monolayers.** Nat. Photonics 14, 256–262 (2020).
- J167. Liu, J., Tian, H., Lucas, E. et al. **“Monolithic piezoelectric control of soliton microcombs”**, Nature 583, 385–390 (2020), doi: 10.1038/s41586-020-2465-8.
- J168. Tian, H., Liu, J., Dong, B. et al. **“Hybrid integrated photonics using bulk acoustic resonators”**, Nat Commun 11, 3073 (2020), doi: 10.1038/s41467-020-16812-6.
- J169. McKenna, T. P., Witmer, J. D., Patel, R. N., Jiang, W., Van Laer, R., Arrangoiz-Arriola, P., ... & Safavi-Naeini, A. H. (2020). **Cryogenic microwave-to-optical conversion using a triply resonant lithium-niobate-on-sapphire transducer.** Optica, 7(12), 1737-1745.
- J170. Lee, N. R., Pechal, M., Wollack, E. A., Arrangoiz-Arriola, P., Wang, Z., & Safavi-Naeini, A. H. (2020). **Propagation of microwave photons along a synthetic dimension.** Physical Review A, 101(5), 053807.
- J171. Sarabalis, Christopher J., Yanni D. Dahmani, Agnetta Y. Cleland, and Amir H. Safavi-Naeini. **“S-band delay lines in suspended lithium niobate.”** Journal of Applied Physics 127, no. 5 (2020): 054501.
- J172. Dahmani, Yanni D., Christopher J. Sarabalis, Wentao Jiang, Felix M. Mayor, and Amir H. Safavi-Naeini. **“Piezoelectric transduction of a wavelength-scale mechanical waveguide.”** Physical Review Applied 13, no. 2 (2020): 024069.
- J173. Jiang, Wentao, Felix M. Mayor, Rishi N. Patel, Timothy P. McKenna, Christopher J. Sarabalis, and Amir H. Safavi-Naeini. **“Nanobenders as efficient piezoelectric actuators for widely tunable nanophotonics at CMOS-level voltages.”** Communications Physics 3, no. 1 (2020): 1-9.
- J174. Witmer, Jeremy D., Timothy P. McKenna, Patricio Arrangoiz-Arriola, Raphaël Van Laer, E. Alex Wollack, Francis Lin, Alex KY Jen, Jingdong Luo, and Amir H. Safavi-Naeini. **“A silicon-organic hybrid platform for quantum microwave-to-optical transduction.”** Quantum Science and Technology 5, no. 3 (2020): 034004.
- J175. Sarabalis, Christopher J., Timothy P. McKenna, Rishi N. Patel, Raphaël Van Laer, and Amir H. Safavi-Naeini. **“Acousto-optic modulation in lithium niobate on sapphire.”** Apl Photonics 5, no. 8 (2020): 086104.
- J176. Jiang, Wentao, Christopher J. Sarabalis, Yanni D. Dahmani, Rishi N. Patel, Felix M. Mayor, Timothy P. McKenna, Raphaël Van Laer, and Amir H. Safavi-Naeini. **“Efficient bidirectional piezo-optomechanical transduction between microwave and optical frequency.”** Nature communications 11, no. 1 (2020): 1-7.
- J177. H. Tian, J. Liu, A. Siddharth et al., **“Magnetic-free silicon nitride integrated optical isolator,”** Nat. Photonics, vol. 15, no. 11, pp. 828–836, Nov. 2021, doi: 10.1038/s41566-021-00882-z.
- J178. Mayor, Felix M., Wentao Jiang, Christopher J. Sarabalis, Timothy P. McKenna, Jeremy D. Witmer, and Amir H. Safavi-Naeini. **“Gigahertz phononic integrated circuits on thin-film lithium niobate on sapphire.”** Physical Review Applied 15, no. 1 (2021): 014039.
- J179. de Beeck, Camiel Op, Felix M. Mayor, Stijn Cuyvers, Stijn Poelman, Jason F. Herrmann, Okan Atalar, Timothy P. McKenna et al. **“III/V-on-lithium niobate amplifiers and lasers.”** Optica 8, no. 10 (2021): 1288-1289.
- J180. Wang, Jiahui, Jason F. Herrmann, Jeremy D. Witmer, Amir H. Safavi-Naeini, and Shanhui Fan. **“Photonic modal circulator using temporal refractive-index modulation with spatial inversion symmetry.”** Physical Review Letters 126, no. 19 (2021): 193901.
- J181. T. Blésin, H. Tian, S. A. Bhave, and T. J. Kippenberg, **“Quantum coherent microwave-optical transduction using high-overtone bulk acoustic resonances,”** Phys. Rev. A, vol. 104, no. 5, p. 052601, Nov. 2021, doi: 10.1103/PhysRevA.104.052601.
- J182. Wang, Zhaoyou, Taha Rajabzadeh, Nathan Lee, and Amir H. Safavi-Naeini. **“Automated discovery of autonomous quantum error correction schemes.”** PRX Quantum 3, no. 2 (2022): 020302.
- J183. Park, Taewon, Hubert S. Stokowski, Vahid Ansari, Timothy P. McKenna, Alexander Y. Hwang, M. M. Fejer, and Amir H. Safavi-Naeini. **“High-efficiency second harmonic generation of blue light on thin-film lithium niobate.”** Optics Letters 47, no. 11 (2022): 2706-2709.
- J184. Herrmann, Jason F., Vahid Ansari, Jiahui Wang, Jeremy D. Witmer, Shanhui Fan, and Amir H. Safavi-Naeini. **“Mirror symmetric on-chip frequency circulation of light.”** Nature Photonics (2022): 1-6.

- J185. Moody, Galan, Volker J. Sorger, Daniel J. Blumenthal, Paul W. Juodawlkis, William Loh, Cheryl Sorace-Agaskar, Alex E. Jones et al. **"2022 Roadmap on integrated quantum photonics."** Journal of Physics: Photonics 4, no. 1 (2022): 012501.
- J186. Stokowski, H.S., McKenna, T.P., Park, T., Hwang, A.Y., Dean, D.J., Celik, O.T., Ansari, V., Fejer, M.M. and Safavi-Naeini, A.H., 2023. **Integrated quantum optical phase sensor in thin film lithium niobate.** Nature Communications, 14(1), p.3355.
- J187. T. W. Hughes, I. A. D. Williamson, M. Minkov, and S. Fan, **"Forward-Mode Differentiation of Maxwell's Equations,"** ACS Photonics 6, 3010–3016 (2019).
- J188. S. Buddhiraju, Y. Shi, A. Song, C. Wojcik, M. Minkov, I. A. D. Williamson, A. Dutt, and S. Fan, **"Absence of unidirectionally propagating surface plasmon-polaritons at nonreciprocal metal-dielectric interfaces,"** Nature Communications 11, 674 (2020).
- J189. J. Wang, Y. Shi, and S. Fan, **"Non-reciprocal polarization rotation using dynamic refractive index modulation,"** Optics Express 28, 11974 (2020).
- J190. A. Dutt, M. Minkov, I. A. D. Williamson, and S. Fan, **"Higher-order topological insulators in synthetic dimensions,"** Light: Science and Applications 9, 131 (2020).
- J191. A. Dutt, Q. Lin, L. Yuan, M. Minkov, M. Xiao, and S. Fan, **"A single photonic cavity with two independent physical synthetic dimensions,"** Science 367, 59–64 (2020).
- J192. L. Yuan, A. Dutt, M. Qin, S. Fan, and X. Chen, **"Creating locally interacting Hamiltonians in the synthetic frequency dimension for photons,"** Photonics Research 8, B8 (2020).
- J193. V. S. Asadchy, C. Guo, B. Zhao, and S. Fan, **"Sub - Wavelength Passive Optical Isolators Using Photonic Structures Based on Weyl Semimetals,"** Advanced Optical Materials 8, 2000100 (2020).
- J194. V. S. Asadchy, M. S. Mirmoosa, A. Diaz-Rubio, S. Fan, and S. A. Tretyakov, **"Tutorial on Electromagnetic Nonreciprocity and its Origins,"** Proceedings of IEEE 108, 1684–1727 (2020).
- J195. I. A. D. Williamson, M. Minkov, A. Dutt, J. Wang, A. Y. Song, and S. Fan, **"Integrated Nonreciprocal Photonic Devices With Dynamic Modulation,"** Proceedings of IEEE 108, 1759–1784 (2020).
- J196. X. Wang, G. Ptitsyn, V. S. Asadchy, A. Diaz-Rubio, M. S. Mirmoosa, S. Fan, and S. A. Tretyakov, **"Nonreciprocity in Bianisotropic Systems with Uniform Time Modulation,"** Physical Review Letters 125, 266102 (2020).
- J197. S. Buddhiraju, A. Dutt, M. Minkov, I. A. D. Williamson, and S. Fan, **"Arbitrary linear transformations for photons in the frequency synthetic dimension,"** Nature Communications 12, 2401 (2021).
- J198. K. Wang, A. Dutt, K. Y. Yang, C. C. Wojcik, J. Vučković, and S. Fan, **"Generating arbitrary topological windings of a non-Hermitian band,"** Science 371, 1240–1245 (2021).
- J199. J. Wang, J. F. Herrmann, J. D. Witmer, A. H. Safavi-Naeini, and S. Fan, **"Photonic Modal Circulator Using Temporal Refractive-Index Modulation with Spatial Inversion Symmetry,"** Physical Review Letters 126, 193901 (2021).
- J200. G. Li, Y. Zheng, A. Dutt, D. Yu, Q. Shan, S. Liu, L. Yuan, S. Fan, and X. Chen, **"Dynamic band structure measurement in the synthetic space,"** Science Advances 7, eabe4335 (2021).
- J201. C. Guo and S. Fan, **"Generation of guided space-time wave packets using multilevel indirect photonic transitions in integrated photonics,"** Phys. Rev. Res. 3, 033161 (2021).
- J202. K. Wang, A. Dutt, C. C. Wojcik, and S. Fan, **"Topological complex-energy braiding of non-Hermitian bands,"** Nature 598, 59–64 (2021).
- J203. X. Wang, V. S. Asadchy, S. Fan, and S. A. Tretyakov, **"Space-Time Metasurfaces for Power Combining of Waves,"** ACS Photonics 8, 3034–3041 (2021).
- J204. L. Yuan, A. Dutt, and S. Fan, **"Synthetic frequency dimensions in dynamically modulated ring resonators,"** APL Photonics 6, 071102 (2021).
- J205. A. Dutt, L. Yuan, K. Y. Yang, K. Wang, S. Buddhiraju, J. Vučković, and S. Fan, **"Creating boundaries along a synthetic frequency dimension,"** Nat. Commun. 13, 3377 (2022).
- J206. L. Fan, Z. Zhao, K. Wang, A. Dutt, J. Wang, S. Buddhiraju, C. C. Wojcik, and S. Fan, **"Multidimensional Convolution Operation with Synthetic Frequency Dimensions in Photonics,"** Phys. Rev. Appl. 18, 034088 (2022).

- J207. O. Y. Long, K. Wang, A. Dutt, and S. Fan, **"Time reflection and refraction in synthetic frequency dimension,"** Phys. Rev. Res. 5, L012046 (2023).
- J208. Y. Shen, Q. Zhan, L. G. Wright, D. N. Christodoulides, F. W. Wise, A. E. Willner, K. Zou, Z. Zhao, M. A. Porras, A. Chong, C. Wan, K. Y. Bliokh, C.-T. Liao, C. Hernandez-Garcia, M. Murnane, M. Yessenov, A. F. Abouraddy, L. J. Wong, M. Go, S. Kumar, C. Guo, S. Fan, N. Papasimakis, N. I. Zheludev, L. Chen, W. Zhu, A. Agrawal, M. Mounaix, N. K. Fontaine, J. Carpenter, S. W. Jolly, C. Dorrer, B. Alonso, I. Lopez-Quintas, M. Lopez-Ripa, J. Sola, J. Huang, H. Zhang, Z. Ruan, A. H. Dorrah, F. Capasso, and A. Forbes, **"Roadmap on spatiotemporal light fields,"** J. Opt. 25, 093001 (2023).
- J209. D. Cheng, K. Wang, and S. Fan, **"Artificial Non-Abelian Lattice Gauge Fields for Photons in the Synthetic Frequency Dimension,"** Phys. Rev. Lett. 130, 083601 (2023).
- J210. X. Wang, M. S. Mirmoosa, V. S. Asadchy, C. Rockstuhl, S. Fan, and S. A. Tretyakov, **"Metasurface-based realization of photonic time crystals,"** Sci. Adv. 9, eadg7541 (2023).
- J211. C. Scarborough and A. Grbic, **"Generalized Eigenvalue Problem for Spatially-Discrete Traveling-Wave Modulated Circuit Networks"** IEEE Trans. Microw. Theory Techn., 71, 2 pp. 511-521, Feb. 2023.
- J212. C.-W. Lin and A. Grbic, **"Field Synthesis with Azimuthally-Varying, Cascaded, Cylindrical Metasurfaces using a Wave Matrix Approach,"** IEEE Trans. Antennas Propag., vol. 71, no. 1, pp. 796-808, Jan. 2023.
- J213. C.-W. Lin and A. Grbic, **"Analysis and Synthesis of Cascaded Cylindrical Metasurfaces using a Wave Matrix Approach,"** IEEE Trans. Antennas Propag., vol. 69, no. 10, pp. 6546-6559, Oct. 2021.
- J214. C. Scarborough, Z. Wu, and A. Grbic, **"Efficient computation of spatially-discrete traveling-wave modulated structures,"** IEEE Trans. Antennas Propag., vol. 69, no. 12, pp. 8512-8525, Sept. 2021.
- J215. Z. Wu, C. Scarborough, A. Grbic, **"Space-time-modulated metasurfaces with spatial discretization: free-space N-path systems,"** Physical Review Applied, 14, 064060, Dec. 2020.
- J216. C. Scarborough and A. Grbic, **"Accelerated N-path network analysis using the Floquet scattering matrix method,"** IEEE Trans. Microw. Theory Techn., vol. 68, no. 4, pp. 1248-1259, April 2020.
- J217. Z. Wu and A. Grbic, **"Serrodyne frequency translation using time-modulated metasurfaces,"** IEEE Trans. Antennas Propag., 68, 3, pp. 1599 – 1606, March 2020.
- J218. G. Ptitsyn, M. S. Mirmoosa, A. Sotoodehfar, and S. A. Tretyakov, **"A tutorial on the basics of time-varying electromagnetic systems and circuits: Historic overview and basic concepts of time-modulation,"** IEEE Antennas and Propagation Magazine, vol. 65, no. 4, pp. 10-20, 2023.
- J219. S. Zhong, X. Wang, and S. A. Tretyakov, **Coherent control of wave beams via unidirectional evanescent modes excitation,** Adv. Funct. Mater., p. 2304300, 2023.
- J220. X. Wang, M. S. Mirmoosa, V. S. Asadchy, C. Rockstuhl, S. Fan, S. A. Tretyakov, **Metasurface-based realization of photonic time crystals,** Science Advances, vol. 9, p. eadg7541, 2023.
- J221. G.A. Ptitsyn, M.S. Mirmoosa, S. Hrabar, and S.A. Tretyakov, **Time-modulated circuits and metasurfaces for emulating arbitrary transfer functions,** Physical Review Applied, vol. 20, p. 014041, 2023.
- J222. M. H. Mostafa, N. Ha-Van, P. Jayathurathnage, X. Wang, G. Ptitsyn, and S. A. Tretyakov, **Antenna bandwidth engineering through time-varying resistance,** Appl. Phys. Lett., vol. 122, no. 17, p. 171703, 2023.
- J223. V. Asadchy, A.G. Lamprianidis, G. Ptitsyn, M. Albooyeh, Rituraj, T. Karamanos, R. Alae, S.A. Tretyakov, C. Rockstuhl, and S. Fan, **Parametric Mie resonances and directional amplification in time-modulated scatterers,** Phys. Rev. Applied, vol. 18, p. 054065, 2022.
- J224. G. Ptitsyn, A. Lamprianidis, T. Karamanos, V. Asadchy, R. Alae, M. Müller, M. Albooyeh, M. S. Mirmoosa, S. Fan, S. Tretyakov, C. Rockstuhl, **Floquet-Mie theory for time-varying dispersive spheres,** Laser Photonics Rev., p. 2100683, 2022.
- J225. M. H. M. Mostafa, M. S. Mirmoosa, and S. A. Tretyakov, **Spin-dependent phenomena at chiral temporal interfaces,** Nanophotonics, doi.org/10.1515/nanoph-2022-0805, 2023.
- J226. F. S. Cuesta, M. S. Mirmoosa, and S. A. Tretyakov, **Emulating bianisotropic coupling through coherent illumination,** Physical Review B, vol. 107, p. 035145, 2023.

- J227. X. Wang, M. S. Mirmoosa, and S. Tretyakov, *Controlling surface waves with temporal discontinuities of metasurfaces*, Nanophotonics, doi:10.1515/nanoph-2022-0685, 2023.
- J228. G. Ptitsyn, M. S. Mirmoosa, A. Sotoodehfar, and S. A. Tretyakov, *A tutorial on the basics of time-varying electromagnetic systems and circuits: Historic overview and basic concepts of time-modulation*, IEEE Antennas and Propagation Magazine, vol. 65, no. 4, pp. 10-20, 2023

IX. Invited, Keynote and Plenary Talks

Michal Lipson:

- OSK Summer Meeting & Joint Symposium, Jesu Island, South Korea, August 27-30.
- OMN 2023, International Conference of Optics and Photonics, Sao Paulo, Brazil, July 30-August 3.
- IEEE Summer Topical Meetings, Sicily, Italy, July 17-20.
- Siegman International School, Dublin, Ireland, June 18-24.
- Conference on Lasers and Electro-Optics (CLEO), San Jose, CA, May 7-12, 2023.
- OFC Conference, San Diego, CA, March 5-9, 2023.
- International conference in Optics (ICO 25), Dresden, Sept 2022.
- Conference on Lasers and Electro-Optics (CLEO), San Jose, June 2022.
- Conference on Lasers and Electro-Optics (CLEO) Pacific Rim, Sapporo, Japan, July
- NanoPhoton conference, DTU, Denmark, June 6-10, 2022.
- CLEO Conference, San Jose, CA, May 15-20, 2022.
- Quantum and Topological Nanophotonics (QTN), Singapore, April 28-30, 2022
- IFGW Summer School of Optics and Photonics, Brazil, (virtual) February 17, 2022
- CU and Tel-Aviv University Engineering Research Symposium, (virtual) October 4-7,
- MURI Annual Conference, (virtual), September 30, 2021.
- Apple Israel, (virtual), September 2, 2021.
- Max Plank Institute, Germany, (virtual), July 15, 2021.
- NanoPhotonics of 2D Materials, (virtual) July, 2020.
- Asia Communications & Photonics Conference, Chengdu, China, November 2019.
- International Optics and Photonics Conference, São Paulo, Brazil, October 2019.
- CLEO/EUROPE-EQEC, Munich, Germany, Jun 2019.

Amir Safavi Naeini:

- Van Laer, R., Jiang, W., Sarabalis, C., Patel, R., Mayor, F., McKenna, T., ... & Safavi-Naeini, A. (2020). Piezo-optomechanics in lithium niobate on silicon-on-insulator for microwave-to-optics conversion. Bulletin of the American Physical Society, 65.
- Patel, R., McKenna, T., Wang, Z., Witmer, J., Jiang, W., Wollack, E., ... & Safavi-Naeini, A. (2020). Optomechanical Quantum State Tomography. Bulletin of the American Physical Society, 65.
- McKenna, T., Witmer, J., Patel, R., Herrman, J., Jiang, W., Arrangoiz-Arriola, P., ... & Safavi-Naeini, A. (2020). A Lithium Niobate Electro-Optic Transducer for Quantum Networks. Bulletin of the American Physical Society, 65.
- Chris Sarabalis, Wentao Jiang, et al, “Acousto-Optics in Lithium Niobate-on-Sapphire” May 2020, CLEO 2020
- Jiang, W., Sarabalis, C.J., Dahmani, Y.D., Patel, R.N., Mayor, F.M., McKenna, T.P., Van Laer, R. and Safavi-Naeini, A.H. “Efficient bidirectional piezo-optomechanical

- transduction between microwave and optical frequency”. CLEO: Applications and Technology (AF3K.4). Optical Society of America. (May 2020)
- Mayor, Felix, Wentao Jiang, et al. “Compact Transducer for GHz phononic Circuit on thin-Film Lithium Niobate on Sapphire”, July 19-23, 2020, IEEE IFCS-ISAF
 - Atalar, Okan, Raphael Van Laer, et al. “Lithium Niobate Resonant Photoelastic Modulator for Time-of-Flight Imaging”, CLEO (May 2020)
 - Herrmann, J. F., Ansari, V., Wang, J., Witmer, J. D., Fan, S., & Safavi-Naeini, A. H. (2021, May). Integrated thin-film lithium niobate non-reciprocal circulator. In CLEO: Science and Innovations (pp. SF1C-6). Optical Society of America.
 - Van Laer, R., Jiang, W., Patel, R. N., Sarabalis, C. J., Cleland, A., McKenna, T. P., ... & Safavi-Naeini, A. H. (2020, May). Piezo-optomechanics in lithium niobate on silicon-on-insulator for microwave-to-optics transduction. In CLEO: Science and Innovations (pp. STu4J-2). Optical Society of America.
 - Sarabalis, C. J., McKenna, T. P., Patel, R. N., & Safavi-Naeini, A. H. (2020, May). Acousto-optics in lithium niobate-on-sapphire. In CLEO: QELS_Fundamental Science (pp. FTh3C-5). Optica Publishing Group.
 - Rajabzadeh, Taha, Christopher J. Sarabalis, Okan Atalar, and Amir H. Safavi-Naeini. "Photonics-to-Free-Space Interface in Lithium Niobate-on-Sapphire." In CLEO: Science and Innovations, pp. STu4J-6. Optica Publishing Group, 2020.
 - Herrmann, Jason F., Vahid Ansari, Jiahui Wang, Jeremy D. Witmer, Shanhui Fan, and Amir H. Safavi-Naeini. "Integrated thin-film lithium niobate non-reciprocal circulator." In CLEO: Science and Innovations, pp. SF1C-6. Optical Society of America, 2021.
 - Stokowski, Hubert S., Timothy P. McKenna, Vahid Ansari, Jatadhari Mishra, Marc Jankowski, Christopher J. Sarabalis, Jason F. Herrmann, Carsten Langrock, Martin M. Fejer, and Amir H. Safavi-Naeini. "Optical Parametric Oscillator in Thin-Film Lithium Niobate with a 130 μ W Threshold." In CLEO: Science and Innovations, pp. SM4L-6. Optica Publishing Group, 2021.
 - McKenna, Timothy P., Hubert S. Stokowski, Vahid Ansari, Jatadhari Mishra, Marc Jankowski, Christopher J. Sarabalis, Jason F. Herrmann, Carsten Langrock, Martin M. Fejer, and Amir H. Safavi-Naeini. "Fully-Resonant Second Harmonic Generation in Periodically Poled Thin-Film Lithium Niobate." In CLEO: Science and Innovations, pp. SM4L-7. Optica Publishing Group, 2021.
 - Wang, Jiahui, Jason Herrmann, Jeremy Witmer, Amir H. Safavi-Naeini, and Shanhui Fan. "Photonic modal circulator using dynamic modulation with mirror symmetry." In 2021 Conference on Lasers and Electro-Optics (CLEO), pp. 1-2. IEEE, 2021.
 - Atalar, Okan, Raphaël Van Laer, Christopher J. Sarabalis, Amir H. Safavi-Naeini, and Amin Arbabian. "Lithium Niobate Resonant Photoelastic Modulator for Time-of-Flight Imaging." In 2020 Conference on Lasers and Electro-Optics (CLEO), pp. 1-2. IEEE, 2020.
 - Jiang, Wentao, Felix Mayor, Sultan Malik, Raphael Van Laer, Rishi Patel, Christopher Sarabalis, Timothy McKenna et al. "Microwave-to-optical quantum frequency conversion with thin-film lithium niobate on silicon-on-insulator piezo-optomechanics." Bulletin of the American Physical Society (2022).
 - Malik, S., Jiang, W., Mayor, F., Gruenke, R., Makihara, T., Multani, K., Cleland, A., Wollack, E., Arrangoiz-Arriola, P. and Safavi-Naeini, A., 2022. Heterogeneous

- integration of high kinetic inductance resonator with thin-film lithium niobate nanomechanical resonators. *Bulletin of the American Physical Society*
- Van Laer, R., Jiang, W., Sarabalis, C., Patel, R., Mayor, F., McKenna, T., Cleland, A., Wollack, E., Arrangoiz-Arriola, P., Witmer, J. and Safavi-Naeini, A., 2020. Piezo-optomechanics in lithium niobate on silicon-on-insulator for microwave-to-optics conversion. *Bulletin of the American Physical Society*, 65.
 - Safavi-Naeini, A. (2022). Transduction of Quantum Information Tutorial Speaker: Amir Safavi-Naeini. *Bulletin of the American Physical Society*.
 - Witmer, Jeremy, Timothy McKenna, Patricio Arrangoiz-Arriola, Edward Wollack, Rishi Patel, Raphael Van Laer, and Amir Safavi-Naeini. "Microwave-to-optical transduction in a silicon-organic-hybrid platform." *Bulletin of the American Physical Society* 65 (2020).
 - McKenna, Timothy, Jeremy Witmer, Rishi Patel, Jason Herrman, Wentao Jiang, Patricio Arrangoiz-Arriola, Edward Wollack, Raphael Van Laer, and Amir Safavi-Naeini. "A Lithium Niobate Electro-Optic Transducer for Quantum Networks." *Bulletin of the American Physical Society* 65 (2020).
 - McKenna, Timothy P., Jeremy D. Witmer, Rishi N. Patel, Wentao Jiang, Raphaël Van Laer, Patricio Arrangoiz-Arriola, E. Alex Wollack, Jason F. Herrmann, and Amir H. Safavi-Naeini. "Cryogenic microwave-to-optical conversion using a triply resonant lithium-niobate-on-sapphire transducer." *Optica* 7, no. 12 (2020): 1737-1745.
 - Makihara, Takuma, Nathan Lee, and Amir Safavi-Naeini. "A parametrically programmable coupled oscillator network implemented using microwave superconducting circuits." *Bulletin of the American Physical Society* (2023).
 - Mayor, Felix M., Wentao Jiang, Sultan Malik, Raphael Van Laer, Timothy P. McKenna, Rishi N. Patel, Jeremy D. Witmer, and Amir H. Safavi-Naeini. "Optically heralded microwave photons." In *CLEO: Fundamental Science*, pp. FTh4A-1. Optica Publishing Group, 2023.
 - Mayor, Felix, Wentao Jiang, Sultan Malik, Raphael Van Laer, Timothy McKenna, Rishi Patel, Jeremy Witmer, and Amir Safavi-Naeini. "Optically heralded microwave photons-Part 1." *Bulletin of the American Physical Society* (2023).
 - Herrmann, Jason F., Devin J. Dean, Christopher J. Sarabalis, Vahid Ansari, Kevin Multani, Timothy P. McKenna, Jeremy D. Witmer, and Amir H. Safavi-Naeini. "Arbitrary electro-optic bandwidth and frequency control in lithium niobate optical resonators." In *CLEO: Science and Innovations*, pp. STh1R-4. Optica Publishing Group, 2023.

Shanhui Fan:

- Keynote Talk, "Exploring non-trivial topology in synthetic dimensions", Active Photonic Platforms XI, SPIE Annual Meeting, August 25, 2020 (presented online).
- Plenary Talk, "Topology in Synthetic and Momentum Spaces", In MetaNano 2020, September 16, 2020 (presented online).
- Plenary Talk, "Topology in the frequency synthetic dimension", in the Waves in Time-Varying Media Workshop Series, organized by Imperial College London. March 31, 2021. (presented online).
- Plenary Talk, "Synthetic Dimension: Topological Physics and Optical Computing", in the OSA Advanced Photonics Congress, July 26, 2021 (presented online).

- Plenary Talk, "Explorations of topological photonics in synthetic dimensions", Asia Communications and Photonics Conference (ACP), Shanghai, China, October 24, 2021. (presented online).
- Keynote Talk, "Explore topological physics in synthetic dimensions", Photonics and Electromagnetics Research Symposium (PIERS 2022), Hangzhou, China, April 25, 2022. (presented online).
- Keynote Talk, "Topology in frequency synthetic dimensions", Topological Photonics Workshop, Donostia-San Sebastian, June 3, 2022 (presented online).
- Keynote Talk, "Synthetic dimensions: from topological physics to classical and quantum computation", The Pittsburgh Quantum Institute Annual Meeting (PQI2022), University of Pittsburgh, Pittsburgh, September 14, 2022.
- Plenary Talk, "Explorations of topological physics and optical computing in synthetic dimensions", the 2022 IEEE Photonics Conference, Vancouver, Canada, November 16, 2022.
- Keynote Talk, "Synthetic dimensions in photonics", the 7th West-Lake Photonics Symposium 2022, College of Optical Science and Engineering, Zhejiang University, Hangzhou, China, December 1, 2022 (Presented online).
- Distinguished Lectures Series, "Synthetic frequency dimensions: from topological physics to optical computing", at the Max Planck Institute for the Science of Light, Erlangen, Germany, July 13, 2023.
- Plenary Talk, "Optical computing and neural network" in the International Symposium on Silicon Based Optoelectronics (ISSBO 2023), Hangzhou, China, July 14, 2023. (Presented online).
- "Dynamic photonic structures: non-reciprocity, gauge potential, and synthetic dimensions", AP483 Optics and Electronics Seminar Series, Ginzton Laboratory, Stanford University, Stanford, California, October 15, 2018.
- "Dynamically photonic structures: non-reciprocity, gauge potential, and synthetic dimensions", Physics Colloquium, Shanghai Jiao Tong University, Shanghai, China, November 13, 2018.
- "Impact of nonlocality on non-reciprocal plasmons", The Winter Colloquium on the Physics of Quantum Electronics (PQE-2019), Snowbird, Utah, January 11, 2019.
- "Nontrivial topology from simple photonic structures", American Physical Society March Meeting, Boston, Massachusetts, March 6, 2019.
- "Aspects of plasmonic device theory: absence of one-way modes in non-reciprocal plasmonics, and graphene plasmonic reflectors", The 9th International Conference on Surface Plasmon Photonics (SPP9), Copenhagen, Denmark, May 30, 2019.
- "Topology of light in scattering matrices and in synthetic space", Nanophotonics: Foundations and Applications, Congressi Stefano Franscini, Monte Verita, Ascona, Switzerland, September 3, 2019.
- "Photonic resonator structures: topology in scattering, and computing applications", 2019 IEEE Photonics Conference, San Antonio, Texas, October 1, 2019.
- "Topology in simple photonic structures and in synthetic dimensions", The 3rd International Workshop on Quantum and Topological Photonics, Nanyang Technological University, Singapore, December 12, 2019.

- "Nontrivial topology induced by dynamic modulations: from gauge potential to synthetic space", OSA Webinar (hosted by the Integrated Optics Technical Group), February 11, 2020.
- "Computing and imaging processing with photonic structures", Department Colloquium, Department of Electrical and Computer Engineering, Boston University, November 19, 2020 (presented online).
- "Computing with photonic structures", Colloquium, College of Optical Science, University of Arizona, December 3, 2020 (presented online).
- "Exploring fundamental physics and optical computing in synthetic dimensions", Seminar Series, Department of Electrical and Computer Engineering, University of California, Santa Cruz, Oct 4, 2021. (presented online).
- "Optical computing in wavevector and in synthetic dimensions", The Winter Colloquium on the Physics of Quantum Electronics (PQE), Snowbird, Utah, January 12, 2022 (presented online).
- "Synthetic dimensions in photonics", Quantum and Nanophotonics Seminar Series, Korean Advanced Institute of Science and Technology (KAIST), February 23, 2022 (presented online).
- "Explore topological physics and optical computing in synthetic dimensions", Condensed and Living Matter Seminar, Department of Physics, University of Pennsylvania, March 30, 2022 (presented online).
- "Exploring Hermitian and non-Hermitian topology in synthetic dimensions", in YIPQS long-term and Nishinomiya-Yukawa memorial workshop on "Novel Quantum States in Condensed Matter 2022", Yukawa Institute for Theoretical Physics, Kyoto University, Kyoto, Japan, November 11, 2022. (Presented online).
- "Topology of separable non-Hermitian bands in two and three dimensions", The 53rd Winter Colloquium on the Physics of Quantum Electronics (PQE-2023), Snowbird, Utah, January 13, 2023.
- "Exploring photonic band topology in synthetic frequency dimensions", The 13th International Symposium on Photonic and Electromagnetic Crystal Structures (PECS-XIII), Kanda-Myoujin Hall, Tokyo, March 30, 2023.
- "Synthetic frequency dimensions: from topological physics to optical computations", ICFO, Barcelona, Spain, June 9, 2023.
- "Thermodynamics of light, and optical computing", Tech Talk, Google, Sunnyvale, California, August 16, 2023.
- "Topological photonics in synthetic frequency dimensions", IEEE Research and Applications of Photonics in Defense Conference (RAPID), Miramar Beach, Florida, September 12, 2023.
- "Optical computing and neural network", Optica Incubator Meeting on Learning From Light, Optica Headquarter, Washington D. C., September 14, 2023.

Andrea Alù:

- June 12-15, 2023 - Montreal, Canada, Plenary talk at Photonics North
- June 12-16, 2023 - Manchester, UK, Plenary award talk at Phononics 2023
- June 27, 2023 - Roma, Italy, Invited seminar at University La Sapienza
- July 2-7, 2023 - Paris, France, Plenary talk at Phonons 2023
- May 22-26, 2023 - Vancouver, Canada, 5 invited talks at URSI EMTS.

- May 24-25, 2023 - New York, NY, Invited talk at Max Planck-NY Center for Quantum
- June 1, 2023 - New York, NY, Invited talk at World Science University
- April 26-27, 2023 - Philadelphia, PA, Invited talk at Franklin Medal workshop
- April 29, 2023 - Buffalo, NY, Invited talk at 127th NY APS Spring symposium
- May 7-12, 2023 - San Jose, CA, Plenary talk at CLEO
- May 15, 2023 - Exeter, UK, Plenary talk at A-Meta Consortium Meeting
- April 18, 2023 - Pittsburgh, PA, PQI Distinguished Seminar at University of Pittsburgh
- April 10-14, 2023 - San Francisco, CA, 3 invited talks at MRS Spring
- April 4-5, 2023 - Veldhoven, Netherlands, Invited talk at NWO Physics
- March 29, 2023 - Chicago, IL, ECE Distinguished Seminar at Northwestern University
- March 1-2, 2023 - Shiraz, Iran. Keynote talk at 29th Iranian Conference on Optics and Photonics
- February 15, 2023 - New York, NY, Presidential Lecture at Simons Foundation
- January 25, 2023 - Tehran, Iran, Plenary talk at MMWATT
- November 27-December 2, 2022 - Boston, MA, 2 invited talks at MRS Fall
- December 2, 2022 - Tucson, AZ, Invited colloquium at University of Arizona
- December 13-15, 2022 - Tehran, Iran, Keynote talk at MMWATT-22
- January 8-13, 2023 - Snowbird, UT, Invited talk at PQE 2023
- November 7-8, 2022 - Jena, Germany, Plenary talk at Workshop on Structured Light
- November 9-11, 2022 – Online, Plenary talk at OPL-22
- October 11, 2022 – Online, Colloquium at OpTalk, University of Exeter
- October 18, 2022 – Online, Colloquium at MetaMat
- October 26, 2022 - Arlington, VA, Colloquium at Virginia Tech Research Center
- October 28, 2022 - State College, PA, Raj and Jeannette Mittra Endowed Lecture
- August 23, 2022 - San Diego, CA, Keynote and invited talks at SPIE Optics and Photonics
- September 5-9, 2022 - Dresden, Germany, Plenary award talk at ICO-25
- September 12-15, 2022 - Siena, Italy, Invited talk at Metamaterials'2022
- July 18-22, 2022 - Firenze, Italy, Keynote talk at 2nd Colloquium on Metasurfaces
- August 1-5, 2022 - Cetraro, Italy, Invited talk at Metamaterials 3.1
- August 4-5, 2022 - Chicago, IL, Invited talk at 15th Futurewei Workshop
- August 13, 2022 - Harbin, China, Keynote talk at 2022 China Microwave Week
- July 4-8, 2022 - Besancon, France, Keynote talk at ETOPIIM 12
- July 6-9, 2022 – Online, Keynote talk at China Microwave Week
- July 10-15, 2022 - Newry, ME, Invited talk at GRC Plasmonics and Nanophotonics
- July 10-15, 2022 - Denver, CO, Invited talk and panel at IEEE AP-S
- June 19-24, 2022 - Austin, TX, Invited talk at USNCTAM
- June 21, 2022 – Online, Invited colloquium at TMOS
- June 1-3, 2022 - San Sebastian, Spain, Keynote talk at Topological Photonics 2022
- June 6-10, 2022 - Siena, Italy, Invited talk at ESOA School of Antennas
- June 7, 2022 - Chicago, IL, Invited talk at JFI Colloquium at University of Chicago
- June 8-9, 2022 - Arlington, VA, Invited talk at Wireless Communications: XG & Beyond
- May 23-27, 2022 - Marseille, France, Invited talk at Herglotz-Nevanlinna Workshop
- May 24-26, 2022 - Niagara Falls, NY, Keynote talk at Photonics North
- April 27, 2022 – Online, Invited colloquium at Stanford Optical Society
- May 4, 2022 – Online, Invited seminar at LMU

- May 8-13, 2022 - Honolulu, HI, Invited talk at MRS Spring
- April 11, 2022 - Miami, FL, Invited colloquium at Florida International University
- April 22, 2022 – Online, Webinar for Optica Optoelectronics Technical Group
- April 25-29, 2022 – Online, Keynote and invited talk at PIERS 2022
- March 9, 2022 - Newark, DE, ECE Distinguished lecture at University of Delaware
- March 21-23, 2022 – Online, Invited talk at KAUST
- March 27 - April 1, 2022 - Madrid, Spain Keynote and 3 invited talks at EUCAP
- February 25, 2022 - Baltimore, MD, Invited colloquium at Johns Hopkins APL
- February 9, 2022 – Online, Invited colloquium at Aalto University
- February 16, 2022 - Online Invited colloquium at UMass Lowell
- January 10-14, 2022 - Snowbird, UT, Invited talk at PQE 2022
- January 22-27, 2022 - San Francisco, CA Invited talk at SPIE Photonics West
- February 7, 2022 - San Diego, CA, Invited seminar at UC San Diego
- December 13, 2021 – Online, Keynote talk at InCAP 2021
- December 6-8, 2021 – Online, Two invited talks at MRS Fall 2021
- December 5-8, 2021 – Online Invited talk at BCICTS 2021
- December 7-10, 2021 – Online Keynote talk at SNAIA 2021
- December 2, 2021 – Online Invited seminar at University of Oklahoma
- December 3, 2021 – Online, Invited seminar at IEEE SSCS Vancouver Chapter
- October 28, 2021 - New York, NY Invited talk at NYU Wireless Workshop
- November 9, 2021 - Bethlehem, PA, Invited colloquium at Lehigh University
- November 9-11, 2021 – Online, Tutorial talk at POEM 2021
- November 12-14, 2021 – Online, Keynote talk at ICOM 2021
- October 21-22, 2021 - New York, NY, Invited talk at Simons Collaboration Annual Meeting
- October 25, 2021 – Online, Plenary talk at Dan Maydan Prize Meeting
- October 24-27, 2021 – Online, Plenary talk at IMOC 2021
- October 26-29, 2021 – Online, Keynote talk at Graphene 2021
- October 9-10, 2021 – Online, Plenary talk at OWT 2021
- October 17-21, 2021 – Online, Invited talk at IEEE Photonics Conference
- October 20-21, 2021 – Online, Invited talk at Huawei Antenna Technology Summit
- October 20-22, 2021 – Online, Keynote talk at SMS 2021
- October 4, 2021 – Online, Ginzton seminar at Stanford University
- September 28, 2021 - New York, NY, Plenary talk at Blavatnik National Award Ceremony
- September 20-25, 2021 – Online, Invited talk at Metamaterials 2021
- September 13-17, 2021 - Roma, Italy, Plenary talk at EOS Annual Meeting
- September 12-15, 2021 – Online, Invited talk at IEEE Ultrasonics Symposium
- September 13-14, 2021 – Online, Opening talk at ARO-Caltech workshop
- September 13-16, 2021 - Paris, France, Invited tutorial at ESOA School on Symmetries
- September 13-17, 2021 – Online, Plenary talk at Metanano
- August 19, 2021 - Online Plenary talk at AAAFM-UCLA 2021 “Metamaterial Structures for Advanced Sensing and Information Processing,” XXXIII General Assembly and Scientific Symposium of the International Union of Radio Science (URSI GASS), Roma, Italy, August 29 - September 5, 2021, (invited talk).

- “Metamaterials Based on Broken Symmetries,” XXXIII General Assembly and Scientific Symposium of the International Union of Radio Science (URSI GASS), Roma, Italy, August 29 - September 5, 2021, (invited talk).
- “Metamaterials Baked on Broken Symmetries,” 2021 IEEE International Conference on Manipulation, Manufacturing and Measurement on the Nanoscale (3M Nano), Xi’an, China, August 2-6, 2021, (keynote talk).
- “Exotic Wave-Matter Interactions in Metamaterials Based on Broken Symmetries,” IEEE Research and Applications of Photonics in Defense (RAPID), August 2-4, 2021, (plenary talk).
- “Spatio-Temporally Modulated Metamaterials,” 2021 International Applied Computational Electromagnetics Society (ACES) Symposium, August 1-5, 2021, (invited talk).
- “Time-Varying Metamaterials,” 2021 International Applied Computational Electromagnetics Society (ACES) Symposium, August 1-5, 2021, (plenary talk).
- “Exotic Scattering Features in Plasmonic Structures,” SPIE Optics and Photonics, San Diego, CA, August 1-5, 2021, (invited talk).
- “Optical Metamaterials Based on Broken Symmetries,” SPIE Optics and Photonics, San Diego, CA, August 1-5, 2021, (invited talk).
- “Magnet-Free Approaches for Nonreciprocal Photonics,” OSA Advanced Photonics Congress, July 26-30, 2021, (tutorial talk).
- “Active, Time-Varying and Nonlinear Metasurfaces for Enhanced Wireless Communications,” Joint European Conference on Networks and Communications (EUCNC) & 6G Summit, Porto, Portugal, June 8-11, 2021, (keynote talk).
- “Spatio-Temporal Metasurfaces,” International Microwave Symposium, Atlanta, GA, June 6-11, 2021, (invited talk).
- “Gain-Free Routes to Parity-Time Symmetry and Non-Hermitian Physics,” SPIE Photonics West, San Francisco, CA, March 6-11, 2021, (invited talk).
- “New Frontiers for Wave Engineering Using Metamaterials,” European Microwave Week, Utrecht, Netherlands, January 10-15, 2021, (plenary talk).
- “Virtual Absorption and Gain Through Excitation at Complex Frequencies,” National Radio Science Meeting, January 4-9, 2021, (invited talk).
- “Optical Metamaterials Based on Broken Symmetries,” Smart Nanomaterials (SNAIA 2020), Paris, France, December 8-11, 2020, (plenary talk).
- “All-Dielectric Nonlocal Metasurfaces,” Smart Nanomaterials (SNAIA 2020), Paris, France, December 8-11, 2020, (invited talk).
- “Magnet-Free Routes to Nonreciprocal Photonics,” ECOC 2020, Brussels, Belgium, December 6-10, 2020, (invited talk).
- “Extreme Wave Interactions in Metamaterials with Broken Symmetries,” MRS Fall and Fall Meeting & Exhibit, Boston, MA, November 28-December 4, 2020, (plenary talk).
- “Exotic Light-Matter Interactions in Metamaterials with Broken Symmetries,” MRS Fall and Fall Meeting & Exhibit, Boston, MA, November 28-December 4, 2020, (tutorial talk).
- “Harnessing Broken Symmetries in Metamaterials for Sensing Applications,” Istituto Nazionale di Ottica (INO) Annual Symposium, Boston, MA, November 28-December 4, 2020, (keynote talk).

- “Exotic Wave-Matter Interactions in Metamaterials Based on Broken Symmetries,” International Mechanical Engineering Congress & Exposition (IMECE), Portland, OR, November 15-19, 2020, (plenary talk).
- “Harnessing Broken Symmetries for Extreme Wave Phenomena,” Simons MPS Annual Meeting, New York, NY, October 15-16, 2020, (plenary talk).
- “Broken Symmetries in Phononic and Mechanical Metamaterials,” Nanoscience Days, October 6-7, 2020, (plenary talk).
- “Non-Reciprocal and Topological Photonics Based on Optical Pumping,” SPIE Optics + Photonics, San Diego, CA, August 23-27, 2020, (keynote talk).
- “Thermal Metasurfaces,” 2020 International Conference on Thermodynamics and Thermal Metamaterials (ThermoMeta2020), August 7-9, 2020, (invited talk).
- “Time-Variations and Gain for the Next Generation of Metamaterials,” Joint Conference of the IEEE International Frequency Control Symposium & IEEE International Symposium on Applications of Ferroelectrics (IEEE IFCS-ISAF), Keystone, CO, July 19-23, 2020, (plenary talk).
- “Hybrid Metasurfaces for Enhanced Light-Matter Interactions and Extreme Polariton Manipulation,” Nanophotonics of 2D Materials (N2D 2020), San Sebastian, Spain, July 13-16, 2020, (invited talk).
- “Beyond Passivity and Reciprocity with Time-Varying Electromagnetic Systems,” IEEE International Symposium on Antennas and Propagation and North American Radio Science Meeting (AP-S 2020), Montreal, Canada, July 5-10, 2020, (invited talk).
- “Broken Symmetries in Acoustic and Mechanical Metamaterials,” European Conference on Acoustic & Mechanical Metamaterials, London, United Kingdom, May 11-13, 2020, (plenary talk).
- “Nanophotonic Engineering of Monolayer Transition Metal Dichalcogenides,” ACS National Meeting & Expo, Philadelphia, PA, March 22-26, 2020, (invited talk).
- “Present and Future Trends in Electromagnetics and Metamaterials,” 14th European Conference on Antennas and Propagation (EuCAP 2020), Copenhagen, Denmark, March 15-20, 2020, (plenary talk).
- “Spatial and Spatio-Temporal Modulations for Advanced Wave Control with Metasurfaces,” 14th European Conference on Antennas and Propagation (EuCAP 2020), Copenhagen, Denmark, March 15-20, 2020, (invited talk).
- “Hybrid Metasurfaces for Enhanced Light-Matter Interactions and Extreme Polariton Manipulation,” Graphene For US, New York, NY, February 20-21, 2020, (keynote talk).
- “TMD-Based Metasurfaces,” SPIE Photonics West, San Francisco, CA, February 1-6, 2020, (invited talk).
- “Non-Reciprocal Devices Based on Optical Pumping,” SPIE Photonics West, San Francisco, CA, February 1-6, 2020, (invited talk).
- “Metamaterials Based on Broken Symmetries,” IPAM Workshop on Theory and Computation for 2D Models (TCM 2020), Los Angeles, CA, January 13-17, 2020, (invited talk).
- “Quantum Metamaterials and Metasurfaces,” 50th Winter Colloquium on the Physics of Quantum Electronics (PQE 2020), Snowbird, UT, January 5-10, 2020, (invited talk).

- “Metamaterials for Quantum Information Technology,” Quantum Workshop: Distributed Quantum Systems Enhanced by Materials Design, Buffalo, NY, October 21-23, 2019, (plenary talk).
- “Mechanical and Acoustic Metamaterials,” 56th Annual Meeting Society of Engineering Science (SES 2019), St. Louis, MO, October 13-15, 2019, (keynote talk).
- “Molding Light and Sound with Metamaterials,” 27th CAST-USA Annual Convention, New York, NY, October 5, 2019, (plenary talk).
- “Non-Reciprocity in Magnetless Passive Devices,” IEEE Photonics Conference, San Antonio, TX, September 29 - October 3, 2019, (invited talk).
- “Metamaterials to Manipulate and Process Light at the Nanoscale,” 6th ACM International Conference on Nanoscale Computing and Communication (ACM NanoCom 2019), Dublin, Ireland, September 25-27, 2019, (plenary talk).
- “Time-Modulated Metamaterials,” Metamaterials 2019, Roma, Italy, September 16-21, 2019, (invited talk).
- “New Frontiers for Sensing Using Metamaterials,” Nocturno Workshop, Metamaterials 2019, Roma, Italy, September 16-21, 2019, (invited talk).
- “Experimental Validation of Maximal Willis Coupling in an Acoustic Meta-Atom,” Metamaterials 2019, Roma, Italy, September 16-21, 2019.
- “Breaking Lorentz Reciprocity Using Metamaterials,” International Conference on Electromagnetics in Advanced Applications, Granada (ICEAA 2019), Spain, September 9-13, 2019, (plenary talk).
- “New Frontiers for Light Control and Manipulation Using Metamaterials,” Nanophotonics and Micro/Nano Optics International Conference (Nanop 2019), Munich, Germany, September 4-6, 2019, (plenary talk).
- “Exotic Scattering Features from Metamaterials,” Applied Inverse Problems Conference (AIP 2019), Grenoble, France, July 8-12, 2019, (plenary talk).
- “Non-Reciprocity Based on Synthetic Momentum Bias,” IEEE International Symposium on Antennas and Propagation and USNC-URSI Radio Science Meeting, Atlanta, GA, July 7-12, 2019, (invited talk).
- “Topological Delay Lines,” IEEE International Symposium on Antennas and Propagation and USNC-URSI Radio Science Meeting, Atlanta, GA, July 7-12, 2019, (invited talk).
- “Topological and Non-Reciprocal Metamaterials,” DIEP Workshop on Topology and Broken Symmetries, Utrecht, Netherlands, July 1-3, 2019, (invited talk).
- “Plasmonic and Polaritonic Metamaterials,” Plasmonica 2019, Napoli, Italy, June 19-21, 2019, (keynote talk).
- “Topological Phenomena in Acoustics,” 41st Photonics and Electromagnetics Research Symposium (PIERS 2019), Roma, Italy, June 17-20, 2019, (invited talk).
- “Exotic Leaky-wave Phenomena in Meta-structures,” 41st Photonics and Electromagnetics Research Symposium (PIERS 2019), Roma, Italy, June 17-20, 2019, (keynote talk).
- “Magnet-free Non-reciprocity and Topological Order in Electromagnetics,” 41st Photonics and Electromagnetics Research Symposium (PIERS 2019), Roma, Italy, June 17-20, 2019, (invited talk).

- “Topological Phononics,” 5th International Conference on Phononic Crystals/Metamaterials, Phonon Transport, Topological Phononics (Phononics 2019), Tucson, AZ, June 3-7, 2019, (plenary talk).
- “Nonreciprocity and Topological Propagation in Time-Modulated Metamaterials,” International Microwave Symposium, Boston, MA, June 2-7, 2019, (invited tutorial).
- “Parity-Time Symmetry and Exceptional Points in Metamaterials,” URSI Commission B International Symposium on Electromagnetic Theory, San Diego, CA, May 27-31, 2019, (invited talk).
- “Coherent Virtual Absorption for Energy Transfer, Storage and Release,” URSI Commission B International Symposium on Electromagnetic Theory, San Diego, CA, May 27-31, 2019, (invited talk).
- “Time-Bandwidth Limit and Reciprocity in Optical Nanostructures,” URSI Commission B International Symposium on Electromagnetic Theory, San Diego, CA, May 27-31, 2019, (invited talk).
- “Topological Metamaterials Based on Magnet-Free Non-Reciprocal Unit Cells,” URSI Commission B International Symposium on Electromagnetic Theory, San Diego, CA, May 27-31, 2019, (invited talk).
- “Nonlinearity-Driven Non-Reciprocal and Topological Photonics,” Photonics North, Quebec City, Canada, May 21-23, 2019, (keynote talk).
- “Nonreciprocal and Topological Photonics,” CLEO 2019, San Jose, CA, May 5-10, 2019, (invited talk).
- “Designer Matter: Meta-Material Interactions with Light, Radio Waves and Sound,” IEEE Long Island Systems, Applications and Technology Conference (LISAT 2019), Farmingdale, NY, May 3, 2019, (keynote talk).
- “Plasmonics over Hybrid Metasurfaces,” MRS Spring Meeting and Exhibit, Phoenix, AZ, April 22-26, 2019, (invited talk).
- “New Frontiers for Wave Manipulation Using Metamaterials,” SPIE Defense Commercial Sensing, Baltimore, MD, April 14-18, 2019, (keynote talk).
- “Topological Metamaterials,” APS March Meeting, Boston MA, March 4-8, 2019, (invited talk).
- “Nonreciprocal Photonics,” SPIE Photonics West, San Francisco, CA, February 2-7, 2019, (invited talk).
- “Metagratings to Mold the Light Wavefront with Large Efficiency,” SPIE Photonics West, San Francisco, CA, February 2-7, 2019, (invited talk).
- “Coherent Control of Light in Metastructures,” SPIE Photonics West, San Francisco, CA, February 2-7, 2019, (invited talk).
- “Magnet-Free Non-Reciprocity in Photonics,” 49th Winter Colloquium on the Physics of Quantum Electronics, Snowbird, UT, January 6-11, 2019, (plenary talk)
- “Coherent Optics for Energy Transfer, Storage and Release,” Nanometa, Seefeld, Austria, January 3-6, 2019, (invited talk).
- “Designer Matter: Meta-Material Interactions with Light and Sound,” International Conference of Young Researchers on Advanced Materials (ICYRAM), Adelaide, Australia, November 3-8, 2018, (plenary talk).
- “New Frontiers for Wave Manipulation Using Metamaterials,” Samsung STF New Frontiers in Metamaterials, Seoul, Korea, October 12-13, 2018, (invited talk).

- “New Frontiers for Wireless Technology Using Metamaterials,” IEEE North Jersey Section 33rd Annual Mini Symposium and Show, October 4, 2018, (invited talk).
- “Nonreciprocal Photonics,” Frontiers in Optics: the 102nd OSA Annual Meeting and Exhibit/Laser Science Conference, Washington, DC, September 16-20, 2018, (invited talk).
- “Slow Light and Nonreciprocity in Metamaterials,” Metamaterials 2018, Espoo, Finland, August 27-September 1, 2018, (invited talk).

X. Other Conference Talks

- I. Datta, S. H. Chae, G. R. Bhatt, B. Li, Y. Yu, C. Park, J. Park, L. Cao, D. N. Basov, J. Hone, and M. Lipson, "Composite photonic platform based on 2D semiconductor monolayers," in Conference on Lasers and Electro-Optics, OSA Technical Digest (Optica Publishing Group, 2019), paper FTu3C.2.
- U. D. Dave and M. Lipson, "Efficient Conversion to Very High Order Modes in Silicon Waveguides," in Conference on Lasers and Electro-Optics, OSA Technical Digest (Optica Publishing Group, 2019), paper SM3J.6.
- U. D. Dave and M. Lipson, "Low Loss Propagation in a Metal-clad Waveguide via PT-Symmetry Breaking," in Conference on Lasers and Electro-Optics, OSA Technical Digest (Optica Publishing Group, 2019), paper FW4D.4.
- M. Zadka, U. D. Dave, and M. Lipson, "High Tolerance of Metamaterial Waveguides to Fabrication Variations," in Conference on Lasers and Electro-Optics, OSA Technical Digest (Optica Publishing Group, 2019), paper SF1J.7.
- G. Liang, H. Huang, S. Shrestha, I. Datta, M. Lipson, and N. Yu, "Efficient Pure Phase Optical Modulator Based on Strongly Over-Coupled Resonators," in Conference on Lasers and Electro-Optics, OSA Technical Digest (Optica Publishing Group, 2019), paper STh3H.1.
- H. Tian, D. Bin, M. Zervas, J. Liu, T. J. Kippenberg and S. A. Bhave, “Stress-Optical Modulator Using Bulk Acoustic Resonant Vibrations”, IFCS-EFTF (2019).
- I. Datta, S. H. Chae, B. S. Lee, B. Li, J. Hone, and M. Lipson, "Platform for ultra-strong modulation in hybrid silicon nitride/2D material photonic structures," in Conference on Lasers and Electro-Optics, OSA Technical Digest (Optica Publishing Group, 2020), paper SF2J.4.
- B. S. Lee, Y. Zhu, A. P. Freitas, G. R. Bhatt, J. Hone and M. Lipson, "Integrated Graphene Electro-Optic Modulator on Si₃N₄ with Increasing Bandwidth at Cryogenic Temperatures," 2020 Conference on Lasers and Electro-Optics (CLEO), San Jose, CA, USA, 2020, pp. 1-2.
- Z. Zhu, U. D. Dave, M. Lipson, and C. Zheng, "Inverse Geometric Design of Fabrication-Robust Nanophotonic Waveguides," in Conference on Lasers and Electro-Optics, OSA Technical Digest (Optica Publishing Group, 2020), paper SF1J.3.
- X. Ji, J. K. Jang, U. D. Dave, C. Joshi, M. Corato-Zanarella, A. L. Gaeta, and M. Lipson, "Ultra-Low Threshold Broadband Soliton Frequency Comb Generation," in Conference on Lasers and Electro-Optics, OSA Technical Digest (Optica Publishing Group, 2020), paper SW3J.6.

- O. A. Jimenez Gordillo, U. D. Dave, and M. Lipson, "Bridging Between Si and Few-Mode Fiber Higher Order Modes," in Conference on Lasers and Electro-Optics, OSA Technical Digest (Optica Publishing Group, 2020), paper SM2O.6.
- M. Corato-Zanarella, X. Ji, A. Mohanty, U. D. Dave, A. L. Gaeta, and M. Lipson, "Overcoming the Trade-Off Between Loss and Dispersion in Microresonators," in Conference on Lasers and Electro-Optics, OSA Technical Digest (Optica Publishing Group, 2020), paper STh1J.1.
- H. Tian, J. Liu, C. Skehan, A. Siddharth, T. J. Kippenberg and S. A. Bhave, "A Nitride Ring Isolator", CLEO (2020).
- J. R. Rodrigues, U. D. Dave, A. Mohanty, X. Ji, I. Datta, R. Gutierrez-Jauregui, V. R. Almeida, A. Ansejo-Garcia, and M. Lipson, "Guiding light at criticality and beyond," in Conference on Lasers and Electro-Optics, OSA Technical Digest (Optica Publishing Group, 2021), paper FM1M.4.
- J. Hinney, A. G. Molina, U. D. Dave, X. Ji, T. Lin, A. L. Gaeta, and M. Lipson, "On demand control of bus-cavity coupling," in Conference on Lasers and Electro-Optics, OSA Technical Digest (Optica Publishing Group, 2021), paper STu1F.3.
- Z. Zhu, U. D. Dave, M. Lipson, and C. Zheng, "Ultra-broadband Nanophotonics via Adaptive Inverse Design," in Conference on Lasers and Electro-Optics, OSA Technical Digest (Optica Publishing Group, 2021), paper SF2B.3.
- O. A. Jimenez Gordillo, U. D. Dave, and M. Lipson, "One-to-one coupling higher order modes in a fiber to higher order modes in silicon waveguide," in Conference on Lasers and Electro-Optics, OSA Technical Digest (Optica Publishing Group, 2021), paper SW3C.4.
- M. Corato-Zanarella, A. Gil-Molina, M. C. Shin, X. Ji, A. Mohanty, and M. Lipson, "Narrow Linewidth, Widely Tunable Integrated Lasers from Visible to Near-IR," in Conference on Lasers and Electro-Optics, OSA Technical Digest (Optica Publishing Group, 2021), paper SF1B.6.
- I. Datta, O. A. Jimenez Gordillo, S. H. Chae, J. Hone, and M. Lipson, "Platform for electrically reconfigurable ring resonator based on TMD-graphene composite waveguides," in Conference on Lasers and Electro-Optics, OSA Technical Digest (Optica Publishing Group, 2021), paper STh5B.1.
- A. Rizzo et al., "Fabrication-Robust Silicon Photonics Platform in Standard 220 nm Silicon Processes," 2021 IEEE 17th International Conference on Group IV Photonics (GFP), Malaga, Spain, 2021, pp. 1-2.
- Anat Siddharth, Terence Blesin, Hao Tian, Wenle Weng, Rui Ning Wang, Junqiu Liu, Sunil A. Bhave, and Tobias J. Kippenberg, "Optical Gyrator and Microwave-to-Optical Converter using HBAR modes", CLEO US (2021 and CLEO Europe 2021).
- H. Tian, J. Liu, A. Siddharth, Terence Blesin, T. J. Kippenberg and S. A. Bhave, "X-band AOM on chip", IEEE MEMS (January 2021).
- R. Maiti et al., "Defect-engineered localized exciton in monolayer WSe₂," 2022 Conference on Lasers and Electro-Optics (CLEO), San Jose, CA, USA, 2022, pp. 1-2.
- A. Gil-Molina et al., "High-Power Fully-Integrated Frequency Comb Generation," 2022 Conference on Lasers and Electro-Optics (CLEO), San Jose, CA, USA, 2022, pp. 1-2.
- I. Datta, X. Ji, G. R. Bhatt, B. S. Lee, and M. Lipson, "Low insertion loss, graphene-based platform for loss modulation," in Conference on Lasers and Electro-Optics, Technical Digest Series (Optica Publishing Group, 2022), paper SM5P.4.

- J. R. Rodrigues, G. R. Bhatt, I. Datta, U. D. Dave, S. Chaitanya, E. Shim, and M. Lipson, "SiN-based waveguides with ultra-low thermo-optic effect," in Conference on Lasers and Electro-Optics, Technical Digest Series (Optica Publishing Group, 2022), paper SM4G.3.
- J. Hinney, U. D. Dave, A. G. Molina, X. Ji, and M. Lipson, "Loading short pulses into long lifetime cavities," in Conference on Lasers and Electro-Optics, Technical Digest Series (Optica Publishing Group, 2022), paper FM5B.3.
- Terence Blésin, Anat Siddharth, et al, "Microwave-optical transduction using high overtone bulk acoustic resonances", APS March Meeting (2022), IFCS-EFTF (2022), CLEO (2022), ECIO (2022)
- A. Novick et al., "CMOS-Fabry Compatible, Broadband, and Compact Routing of Multimode SOI Waveguides," 2023 Optical Fiber Communications Conference and Exhibition (OFC), San Diego, CA, USA, 2023, pp. 1-3, doi: 10.1364/OFC.2023.M4I.1.
- M. Corato-Zanarella, X. Ji, A. Mohanty, and M. Lipson, "Pushing the Limits of Photonics in the Visible Spectrum," in CLEO 2023, Technical Digest Series (Optica Publishing Group, 2023), paper SF3K.1.
- Z. Zhu, J. R. Rodrigues, M. Lipson, and C. Zheng, "Inverse Design of Fabrication-Robust, Low-Loss, and Compact Waveguide Bends," in CLEO 2023, Technical Digest Series (Optica Publishing Group, 2023), paper JTU2A.121.
- A. Gil-Molina, Y. Antman, O. Westreich, X. Ji, M. C. Shin, G. R. Bhatt, I. Datta, B. Y. Kim, Y. Okawachi, A. L. Gaeta, and M. Lipson, "WDM Transmission via High-Power Fully-Integrated Kerr Frequency Combs," in CLEO 2023, Technical Digest Series (Optica Publishing Group, 2023), paper STU4L.1.
- K. J. McNulty, X. Ji, A. Gil-Molina, M. Corato-Zanarella, G. R. Bhatt, I. Datta, S. Chaitanya, Y. Okawachi, A. L. Gaeta, and M. Lipson, "Low Stress Bilayer LPCVD-PECVD SiN Waveguides for Kerr Frequency Comb Generation," in CLEO 2023, Technical Digest Series (Optica Publishing Group, 2023), paper STh1J.2.
- J. Hinney, S. Kim, G. J. K. Flatt, I. Datta, A. Alù, and M. Lipson, "Efficient Power Transfer via Induced Virtual Critical Coupling in an Overcoupled Silicon Nitride Microresonator," in CLEO 2023, Technical Digest Series (Optica Publishing Group, 2023), paper JTh2A.69.
- J. R. Rodrigues, U. D. Dave, A. Mohanty, X. Ji, I. Datta, S. Chaitanya, G. Bhatt, R. Gutierrez-Jauregui, V. R. Almeida, A. Asenjo-Garcia, and M. Lipson, "Integrated photonics demonstration of zero-curvature eigenfunctions," in CLEO 2023, Technical Digest Series (Optica Publishing Group, 2023), paper FF3D.6.
- Terence Blésin, Wil Kao, Anat Siddharth, et al, "Bidirectional microwave-optical transduction based on bulk acoustic resonators-silicon nitride integrated photonics co-integration", IBM Quantum Transduction Workshop (2023).
- A. Grbic and C. Scarborough, "Time and Space-Time Varying Electromagnetic Structures and Circuits," short course, European Conference on Antennas and Propagation, https://www.eucap2023.org/_files/ugd/001042_ecb5016674b642488df75c9145323209.pdf, March 31, 2023. ,
- A. Grbic, C. Scarborough, Z. Fritts, and Z. Wu, "Analysis and design of N-path systems: space-time modulated circuits and metasurfaces" in Virtual Workshop,

WMH: Spatiotemporal Metastructures for Microwave Applications, International Microwave Symposium, Atlanta, GA, June 2021.

-
- Z. Fritts and A. Grbic, "Increasing the Efficiency-Bandwidth of Small Antennas by Coupling Radiative and Non-Radiative Modes Using Time-Variation," USNC URSI National Radio Science Meeting, pp 77-78, Boulder, Colorado, Jan. 9-13, 2023 (invited).
- S. Young, Z. Fritts, and A. Grbic, "Increasing the Efficiency-Bandwidth Product of Electrically-Small Antennas by Time-Dependent Parametric Coupling of Characteristic Modes," IEEE International Symposium on Antennas and Propagation and USNC-URSI Radio Science Meeting (APS/URSI), Portland, OR, Jul. 23-28, 2023.
- C. Scarborough, Q. Chen, Z. Wu, and A. Grbic, "Simulating Space-Time Structures using Commercial Solvers," IEEE International Symposium on Antennas and Propagation and USNC-URSI Radio Science Meeting (APS/URSI), pp. 1, Denver, CO, Jul. 10-15, 2022.
- Z. Fritts and A. Grbic, "Time-Varying, Subwavelength Spherical Resonators: Circuit Modeling and Insights," Waves in Time Varying Media Workshop, New York, NY, May 3-5, 2023.
- C. Scarborough and A. Grbic, "Spatially-Discrete Traveling-Wave Modulation: A Higher-Order Space-Time Symmetry," European Conference on Antennas and Propagation (EuCAP), pp 1-4, Madrid, Spain, Mar. 27 – Apr. 01, 2022 (invited).
- Z. Fritts and A. Grbic, "Circuit Models for Electrically-Small Time-Varying Spherical Scatterers," URSI National Radio Science Meeting, pp 1-2, Boulder, Colorado, Jan. 4-8, 2022 (invited).
- C.-W. Lin and A. Grbic, "A Wave Matrix Approach to Designing Azimuthally-Varying Cylindrical Metasurfaces," IEEE International Symposium on Antennas and Propagation and USNC-URSI Radio Science Meeting (APS/URSI), Marina Bay Sands, Singapore, Dec. 2021.
- C. Scarborough and A. Grbic, "Generalized eigenvalue problem for spatially-discrete traveling-wave-modulated circuit networks" IEEE International Symposium on Antennas and Propagation and USNC-URSI Radio Science Meeting (APS/URSI), pp. 1-2, Marina Bay Sands, Singapore, Dec. 4-10, 2021.
- C. Scarborough and A. Grbic, "Efficient Subharmonic Frequency Conversion Using Space-Time Coupled Bound States in the Continuum," International Congress on Artificial Materials for Novel Wave Phenomena (Metamaterials), pp. 1-3, New York, New York, Sept. 20-25, 2021, Finalist in Student Paper Competition.
- C. Scarborough, "A Novel Boundary Condition for Spatially-Discrete Traveling-Wave Modulation," Waves in Time-Varying Media" Workshop Series, poster, June 30, 2021, Finalist, OSA Early Career Best Poster Competition.
- Z. Wu, "Space-Time Modulated Metasurfaces with Finite Stixel Size: Three Operation Regimes," Waves in Time-Varying Media" Workshop Series, poster, June 30, 2021
- C. Scarborough and A. Grbic, "The interpath relation for spatially-discrete traveling-wave modulated structures," European Conference on Antennas and Propagation (EuCAP), Dusseldorf, Germany, pp. 1-4, Mar. 22-26, 2021 (invited), First Place in Best Student Paper Award and Finalist for Best Electromagnetics Paper Award.

- Z. Wu, C. Scarborough and A. Grbic, “Retroreflective subharmonic frequency translation with a spatiotemporal metasurface,” International Congress on Advanced Electromagnetic Materials in Microwaves and Optics (Metamaterials), pp. 1-3, New York, NY, Sept. 28-Oct. 3, 2020.
- C. Scarborough and A. Grbic, “Modified Floquet boundary condition for open boundary problems with N-Path symmetry,” International Congress on Advanced Electromagnetic Materials in Microwaves and Optics (Metamaterials), pp. X027-X029, New York, NY, Sept. 28-Oct. 3, 2020, Exceptional Student Contributions Award.
- F. Salas and A. Grbic, “A phase conjugating metasurface,” International Congress on Advanced Electromagnetic Materials in Microwaves and Optics (Metamaterials), pp. 1-3, New York, NY, Sept. 28-Oct. 3, 2020.
- Z. Wu, C. Scarborough, A. Grbic, “Subharmonic Mixing Using a Reflective Spatio-Temporally Modulated Metasurface,” IEEE USNC-CNC-URSI North American Radio Science Meeting (Joint with AP-S Symposium), pp. 1 (abstract), Montreal, QC, July 5-10, 2020.
- Z. Wu, C. Scarborough, and A. Grbic, “A Spatio-temporally modulated metasurface as a free-space N-path system,” European Conference on Antennas and Propagation (EuCAP), pp. 1-2, Copenhagen, Denmark, Mar. 15-20, 2020 (invited), Finalist, Best Electromagnetics Paper Award.
- F. Salas, Z. Wu, C. Scarborough, and A. Grbic, “Floquet analysis of a time-modulated metasurface,” International Congress on Advanced Electromagnetic Materials in Microwaves and Optics (Metamaterials), pp. 1-3, Rome, Italy, Sept. 16-19, 2019.
- D. Sarkar, C. Scarborough, Z. Wu, and A. Grbic, “Time-varying phase control for frequency translation,” IEEE International Symposium on Antennas and Propagation and USNC-URSI Radio Science Meeting, pp. 1-2, Atlanta, GA, July 7-12, 2019.
- A. Grbic, C. Scarborough, F. Salas, and Z. Wu, “Time-modulated metamaterials and metasurfaces: Design and Analysis,” International Conference on Electromagnetics in Advanced Applications (ICEAA), pp. 0313, Granada Spain, Sept. 9-13, 2019 (invited).
- X. Wang, M. S. Mirmoosa, V. Asadchy, and S. Tretyakov, Electromagnetic phenomena in time-modulated metasurfaces, 2022 Sixteenth International Congress on Artificial Materials for Novel Wave Phenomena (Metamaterials), pp. 460-462, 2022.
- M. H. Mostafa, M. S. Mirmoosa, and S. A. Tretyakov, Temporal discontinuity for splitting polarization states of light, 2022 Sixteenth International Congress on Artificial Materials for Novel Wave Phenomena (Metamaterials), pp. 320-322, 2022.
- F. S. Cuesta, M. S. Mirmoosa, and S. A. Tretyakov, Pseudo-bianisotropic coupling through coherent illumination, 2022 Sixteenth International Congress on Artificial Materials for Novel Wave Phenomena (Metamaterials), pp. 119-121, 2022.
- V. Asadchy, A.G. Lampranidis, G. Ptitsyn, M. Albooyeh, Rituraj, T. Karamanos, R. Alaei, S.A. Tretyakov, C. Rockstuhl, and S. Fan, Mie resonances and Kerker effects in parametric time-modulated spheres, 2022 Sixteenth International Congress on Artificial Materials for Novel Wave Phenomena (Metamaterials), pp. 25-27, 2022.
- G. Ptitsyn, M. S. Mirmoosa, S. Hrabar, and S. A. Tretyakov, Time-varying elements for realization of stable non-Foster circuits and metasurfaces, 2022 Sixteenth

International Congress on Artificial Materials for Novel Wave Phenomena (Metamaterials), pp. 347-349, 2022.

XI. Patents and Patent Disclosures

US Patent No. 10,673,407, with title ‘Microelectromechanical Resonant Circulator,’ joint inventors: Matteo Rinaldi, Cristian Cassella, Andrea Alù, Dimitrios Sounas, Ahmed Kord, assignee: Northeastern University; Board of Regents, The University of Texas System, File date: November 14, 2017; Grant date: June 2, 2020.

US Patent No. 10,804,583, World Patent No. 2018/052935, with title ‘Magnetless Non-Reciprocal Devices Using Modulated Filters,’ joint inventors: Ahmed Kord, Dimitrios Sounas, Andrea Alù, assignee: Board of Regents, The University of Texas System, File date: September 13, 17 Grant date: October 13, 2020. [Licensed to Silicon Audio RF Circulator, LLC]

US Provisional Patent Application, with title ‘Non-Foster Antennas and Resonators Beyond Chu’s Limit with Floquet Impedance Matching,’ joint inventors: Andrea Alù, Huanan Li, Ahmed Makkawy, assignee: City University of New York, April 3, 2019.

US Provisional Patent Application, with title ‘N-Way, Ultra-Broadband, Magnetic-Free Non-Reciprocity based in Switched-Capacitor Networks,’ joint inventors: Aravind Nagulu, Mykhailo Tymchenko, Andrea Alù, Harish Krishnashwamy, assignee: Columbia University, City University of New York, September 17, 2019.

US Provisional Patent Application No. 63333696, with title ‘Dispersion Engineered Load to Extend the Bandwidth of Electrically Small Antennas,’ joint inventors: Younes Radi, Ahmed Makkawy, Andrea Alù, assignee: City University of New York, April 22, 2022.

US Provisional Patent Application, with title ‘Passive Optical Retro Reflective Identification Tagging for Optical Positioning,’ joint inventors: Sang-Yeon Cho, Weimin Zhou, Andrea Alù, Adam C. Overvig, assignee: Army Research Laboratory, City University of New York, March 2023.

US Provisional Patent Application, with title ‘Leaky-Wave Metasurface Antennas for Arbitrary Aperture Synthesis,’ joint inventors: Andrea Alù, Gengyu Xu, Adam C. Overvig, Yoshiaki Kasahara, assignee: City University of New York, April 10, 2023.

US Provisional Patent Application, with title ‘Passive Optical Metasurface Performing Analog Spatio-Temporal Differentiation for Event-Based Image Processing,’ joint inventors: Andrea Alù, Michele Cotrufo, Sedigheh K. Esfahani, assignee: City University of New York, July 2023.

U.S. Patent Application, Inventors: A. Grbic and C. Scarborough, Efficient Computation of Spatially-Discrete Traveling-Wave Modulated Structures, Application No.: 17/898,622, Filing Date: August 30, 2022

XII. Supported Students

- Gaurang Bhatt (Columbia U.)
- Jakob Hinney (Columbia U.)
- Kaiyuan Yao (Columbia U.)
- Utsav Dave (Columbia U.)
- Janderson Rodrigues (Columbia U.)
- Ipshita Datta (Columbia U.)
- Mateus Corato Zanarella (Columbia U.)
- FNU Shridha Chaitanya (Columbia U.)
- Vivian Zhou (Columbia U.)
- Anat Siddharth (EPFL)
- Terence Blésin (EPFL)
- Raphael Van Laer (post-doc, Stanford) -> Professor at Chalmers
- Nathan Lee (graduate student, Stanford) -> Research Staff at HRL
- Wentao Jiang (graduate student, Stanford) -> Joined Start-up based on Lab's technology (Flux)
- Rishi Patel (graduate student, Stanford) -> Research Staff at Amazon Quantum Computing
- Vahid Ansari (post-doc, Stanford)
- Jason Herrmann (graduate student, Stanford)
- Hubert Stokowski (graduate student, Stanford)
- Jiahui Wang (Stanford) Now at Google X
- Siddarth Buddhiraju (Stanford) Now at Meta
- Lingling Fan (Stanford) Now a postdoc at MIT
- Kai Wang, (Stanford), Now an Assistant Professor at McGill University, Canada).
- Avik Dutt (Stanford), Now an Assistant Professor at University of Maryland
- Dali Cheng (Stanford)
- Cody Scarborough (U Michigan), Assistant Professor, Colorado University, Boulder.
- Zhanni Wu (U Michigan), Postdoctoral Fellow, UC Berkeley, Sept. 2021 –.
- Debjit Sarkar (U Michigan), Ph.D. student, EE, Caltech, Sept. 2020 –.
- Sara Azzouz (U Michigan), Ph.D. student, EE, Stanford University, Sept. 2022 –.
- Zachary Fritts (U Michigan), Ph.D. Student
- Amirhossein Babae (U Michigan), Ph.D. Student
- Chun-Wen Lin (U Michigan), Ph.D. Student
- Debjit Sarkar (U Michigan), Undergraduate Student
- Sara Azzouz (U Michigan), Undergraduate Student
- Ryan Strohmman (U Michigan), Undergraduate Student
- Shixiong Yin (CUNY)
- Sander Mann (CUNY)
- Hady Moussa (CUNY, now at Qualcomm)
- Ahmed Mekkawy (CUNY, now at Apple)
- Michele Cotrufo (CUNY, now at U Rochester)

XIII. DoD Collaborators

- Dr. Carl Pfeiffer, Air Force Research Laboratory
- Dr. Ilya Vitebskii, Air Force Research Laboratory
- Dr. Jimmy Touma, Air Force Research Laboratory
- Dr. Weimin Zhou, Army Research Laboratory
- Dr. Sang-Yeon Cho, Army Research Laboratory
- Dr. Jesse Frantz, Navy Research Laboratory

XIV. Awards

Michal Lipson:

- Optical Fiber Communication Conference and Exposition (OFC) Award, 2021
- Board advisor on the board of directors, POET Technologies, 2022
- Top 1% most highly cited researcher in Physics since 2014, by Thomson-Reuter
- John Tyndall Award, IEEE Photonics and Optica Societies, 2021.
- Elected member of the American Academy of Arts and Sciences, 2020
- Elected Member of the National Academy of Sciences (NAS), 2019
- Comstock Prize in Physics (NAS), 2019. Awarded once every 5 years, for “innovative discovery or investigation in electricity, magnetism, or radiant energy, broadly interpreted.”
- IEEE Photonics Award 2019. The award is presented for outstanding achievements in photonics and is the highest IEEE honor in photonics.
- Honorary Degree of Doctor in Science, Trinity College of Dublin, 2018.

Amir Safavi-Naeini:

- Sloan Fellowship (2020)
- NSF CAREER Award (2020)
- DARPA Director’s Fellowship (2021)
- Chambers Fellow (2021)
- Moore Inventor Fellowship (2022)

Jason Herrmann: NSF Graduate Research Fellowship (2020)

Hubert Stokowski: Stanford Graduate Fellowship (2020)

Felix Mayor: Best Poster Award (Hybrid Optomechanics Meeting, Ascona Switzerland, 2020)

Shanhui Fan:

- R. W. Wood Prize, Optica (2022).
- Simons Investigator in Physics (2021).

Anthony Grbic:

- Anthony Grbic, John. L. Tishman Professor of Engineering, endowed professorship, College of Engineering, University of Michigan, Jul. 1, 2023
- Anthony Grbic, Senior Associate Chair, departmental leadership position, Electrical and Computer Engineering, University of Michigan, Jun. 1, 2023

- Anthony Grbic, Microwave Theory and Techniques Society (MTT-S) Distinguished Microwave Lecturer (DML), Jan. 2022 - Jan. 2025. Grbic's DML is entitled "Extreme Field Control with Electromagnetic Metasurfaces". DMLs are internationally recognized experts and technical leaders in their fields within the Society. The DMLs present talks to local chapters world-wide and serve as ambassadors for the MTT-S. They travel to MTT-S Chapters or Joint Chapters with other IEEE Societies, Student Chapters.
- Cody Scarborough, Finalist, Best Electromagnetics Paper Competition, European Conference on Antennas and Propagation (EuCAP), Mar. 2022
- Anthony Grbic, David E. Liddle Research Excellence Award, College of Engineering, University of Michigan, March 2022.
- Cody Scarborough, First Place, Student Paper Competition, International Congress on Artificial Materials for Novel Wave Phenomena (Metamaterials 2021). This symposium is the premier international conference on Metamaterials, Sept. 2021.
- Cody Scarborough and Zhanni Wu, joint third place, Best Experimental Poster Competition sponsored by the Optical Society of America (OSA) at the Waves in Time-Varying Media Workshop Series, June 30, 2021, for the following papers:
 - C. Scarborough and A. Grbic, "A novel boundary condition for spatially-discrete traveling-wave modulation," Waves in Time-Varying Media Workshop Series, poster, June 30, 2021, Finalist, OSA Early Career Best Poster Competition.
 - Z. Wu, C. Scarborough, and A. Grbic, "Space-time modulated metasurfaces with finite stixel size: Three Operation Regimes," Waves in Time-Varying Media Workshop Series, poster, June 30, 2021, Finalist, OSA Early Career Best Poster Competition.
- Cody Scarborough, Finalist, Student Paper Competition, International Congress on Artificial Materials for Novel Wave Phenomena (Metamaterials), Sept. 2021, for the following paper:
 - C. Scarborough and A. Grbic, "Efficient subharmonic frequency conversion using space-time coupled bound states in the continuum," International Congress on Artificial Materials for Novel Wave Phenomena (Metamaterials), pp. 1-3, New York, New York, Sept. 20-25, 2021.
- Anthony Grbic, IET A.F. Harvey Prize 2021, shortlisted with five others worldwide. Invited to submit a proposal for the final stage (stage 2) of the selection process. <https://www.theiet.org/impact-society/awards-scholarships/a-f-harvey-prize/>
- Cody Scarborough and Anthony Grbic, First Place, Best Student Paper Award, <https://www.eucap2021.org/awards/eucap-best-paper-awards-and-best-student-paper-awards-winners>, European Conference on Antennas and Propagation (EuCAP), March 2021, for the following paper:
 - C. Scarborough and A. Grbic, "The interpath relation for spatially-discrete traveling-wave modulated structures," European Conference on Antennas and Propagation (EuCAP), Dusseldorf, Germany, pp. 1-4, 2021, Mar. 22-26, 2021 (invited).
- Cody Scarborough and Anthony Grbic, Finalist, Best Electromagnetics Paper Award, European Conference on Antennas and Propagation (EuCAP), March 2021, for the following paper:
 - C. Scarborough and A. Grbic, "The interpath relation for spatially-discrete traveling-wave modulated structures," European Conference on Antennas and Propagation (EuCAP), Dusseldorf, Germany, pp. 1-4, 2021, Mar. 22-26, 2021 (invited).

- Zhanni Wu, Participant, Rising Stars 2020, University of California, Berkeley. https://www2.eecs.berkeley.edu/risingstars/2020/participants/wu_z.shtml. Participants are selected based on academic excellence, interest in a faculty career in computer science, computer engineering and electrical engineering, and a commitment to advancing equity and inclusion. Rising Stars is an intensive workshop aimed at increasing the number of women interested in pursuing academic careers. This annual event was launched at MIT in 2012 and previously hosted by UC Berkeley in 2014.
- Cody Scarborough, Exceptional Student Contributions Award, <https://congress2020.metamorphose-vi.org/index.php/awards>, International Congress on Artificial Materials for Novel Wave Phenomena (Metamaterials 2020), September 2020, for the paper:
- C. Scarborough and A. Grbic, “Modified Floquet boundary condition for open boundary problems with N-Path symmetry,” International Congress on Artificial Materials for Novel Wave Phenomena (Metamaterials 2020), pp. X027-X029, New York, NY, Sept. 28-Oct. 3, 2020.
- Zachary Fritts, Awardee, NSF Graduate Research Fellowship Program, Sept. 2020.

Andrea Alù:

- May 16, 2023:** IEEE AP-S Distinguished Achievement Award
IEEE Antennas and Propagation Society
The Distinguished Achievement Award is given annually to recognize outstanding career achievement by an individual in the field of antennas and propagation. The Prize consists of 2,000\$ and a certificate.
- April 4, 2023:** 2022 Editor-in-Chief Choice Award for Advanced Photonics
Advanced Photonics, SPIE
With the paper “Photonics of time-varying media”, *Advanced Photonics*, Vol. 4, No. 1, 014002 (32 pages), February 14, 2022.
The Advanced Photonics Editor-in-Chief Choice Awards recognize exceptional papers, based on the importance of the work to the optics and photonics field.
- March 11, 2023:** 2021 Brillouin Medal
International Phononics Society
The Brillouin Medal honors a specific seminal contribution, as presented by up to three related publications, by a single researcher or up to three researchers working in collaboration, in the field of phononics (including phononic crystals, acoustic/elastic metamaterials, wave propagation in periodic structures, nanoscale phonon transport, coupled phenomena involving phonons, topological phononics, and related areas).
- November 6, 2022:** Annual Award of eLight
eLight, Springer Nature
For the manuscript ‘Floquet metamaterials,’ which has been selected as highly downloaded/cited paper in eLight.
- September 16, 2022:** 2022 Highly Cited Researcher

Clarivate Analytics Web of Science

Highly Cited Researchers earn this distinction because, during the previous decade, they produced multiple highly cited papers. These are defined as papers ranking in the top 1% by citations, considering both year and field of publication.

April 1, 2022:

Distinguished Professor

City University of New York

The title of Distinguished Professor is conferred on an individual by the University Board of Trustees in recognition of exceptional scholarly achievement. CUNY Distinguished Professors comprise a small number of exceptional individuals. That number is currently limited to 250. Distinguished Professorships are reserved for faculty with records of exceptional performance by national and international standards of excellence in their profession. This honor is granted in recognition of the quality and impact of the nominee's scholarship.

November 16, 2021:

2021 Highly Cited Researcher

Clarivate Analytics Web of Science

Highly Cited Researchers earn this distinction because, during the previous decade, they produced multiple highly cited papers. These are defined as papers ranking in the top 1% by citations, considering both year and field of publication.

June 7, 2021:

AAAFM-Heeger Award

American Association for Advances in Functional Materials

'For his seminal contributions to the realization of engineered functional materials and metamaterials, and their applications in electromagnetics, photonics and acoustics'

The AAAFM-Heeger Award (named after Alan J. Heeger, Nobel Laureate) is a prestigious prize conferred on an outstanding, dynamic young researcher for their outstanding achievements and contributions to the field of Functional Materials. The maximum age considered is 45 years. The awards will be presented at the 3rd AAAFM-UCLA Conference on Functional Materials, which will be held in University California, Los Angeles, June 16-18, 2021.

June 4, 2021:

Blavatnik National Award for Young Scientists (Laureate)

The New York Academy of Sciences – Physical Sciences and Engineering Category

The Blavatnik National Awards honor America's most innovative young faculty-rank scientists and engineers. These awards celebrate the past accomplishments and future potential of young faculty members working in three disciplinary categories of science and engineering. The Blavatnik National Awards are conferred at a formal ceremony in New York City each fall. The Laureate receives \$250,000, the largest unrestricted scientific prize for America's most innovative young faculty-rank scientists and engineers.

April 7, 2021:

Dan Maydan Prize in Nanoscience and Nanotechnology

The Hebrew University of Jerusalem, Center for Nanoscience and Nanotechnology

'For his seminal contributions to nano-optics, nano-photonics, plasmonics and phononics, including the discovery of giant non-reciprocity, non-linear phenomena, and enhanced light-matter interactions using nanostructured materials, metasurfaces and metamaterials'

The \$10,000 Dan Maydan Prize in Nanoscience Research is awarded annually to an outstanding mid-career scientist for significant academic achievements in

nanoscience and nanotechnology. The prize enables an interchange of knowledge between the Center's scientists and nanoscientists worldwide.

- March 16, 2021:** Materials Research Society Fellowship
Materials Research Society
'For seminal contributions to the realization of engineered materials and metamaterials, and their several applications in electromagnetics, photonics and acoustics'
The title of MRS Fellow honors those MRS members who are notable for their distinguished research accomplishments and their outstanding contributions to the advancement of materials research, world-wide. The maximum number of new Fellow appointments each year is limited up to 0.2% of the current MRS regular membership and to those with continuous engagement with MRS. Thus, the distinction is highly selective.
- Sep. 22, 2020:** Breakthrough of the Year in Physics
Physics World
With the paper G. Hu, Q. Ou, G. Si, Y. Wu, J. Wu, Z. Dai, A. Krasnok, Y. Mazor, Q. Zhang, Q. Bao, C. W. Qiu, and A. Alù, "Topological Polaritons and Photonic Magic Angles in Twisted α -MoO₃ Bilayers," *Nature*, Vol. 582, pp. 209-213, June 11, 2020.
- Sep. 22, 2020:** 2020 Highly Cited Researcher
Clarivate Analytics Web of Science
Highly Cited Researchers earn this distinction because, during the previous decade, they produced multiple highly cited papers. These are defined as papers ranking in the top 1% by citations, considering both year and field of publication.
- June 23, 2020:** Simons Collaboration on Extreme Wave Phenomena Based on Symmetries
Simons Foundation
Simons Collaborations bring together groups of outstanding scientists to address topics of fundamental scientific importance in which a significant new development has created a novel area for exploration in an established field. They provide up to 16M\$ of funding for up to 8 years of basic research activities.
- Nov. 26, 2019:** National Academy of Inventors Fellowship
National Academy of Inventors
'For having demonstrated a highly prolific spirit of innovation in creating or facilitating outstanding inventions that have made a tangible impact on the quality of life, economic development, and welfare of society'
Election to NAI Fellow status is the highest professional distinction accorded solely to academic inventors. The program has 1,060 Fellows worldwide representing more than 250 prestigious universities and governmental and non-profit research institutes. Collectively, the Fellows hold more than 38,000 issued U.S. patents, which have generated over 11,000 licensed technologies and companies, and created more than 36 million jobs. In addition, over \$1.6 trillion in revenue has been generated based on NAI Fellow discoveries. With the induction of the 2018 class, there are now more than 125 presidents and senior leaders of research universities and non-profit research institutes, 502 members of the National Academies of Sciences, Engineering, and Medicine; 40 inductees of the National Inventors Hall of Fame, 57

recipients of the U.S. National Medal of Technology and Innovation and U.S. National Medal of Science, 34 Nobel Laureates, 3 Queen Elizabeth Prize for Engineering recipients, 304 AAAS Fellows, 200 IEEE Fellows, and 164 Fellows of the American Academy of Arts & Sciences, among other awards and distinctions.

- Oct. 25, 2019:** AAAS Fellowship
American Association for the Advancement of Science
‘For distinguished contributions to the field of electromagnetics and photonics, particularly for the modeling and applications of artificial materials and metamaterials’
AAAS member whose efforts on behalf of the advancement of science or its applications are scientifically or socially distinguished may, by virtue of such meritorious contribution, be elected a Fellow by the Council.
- Sep. 16, 2019:** MDPI Best Paper Award
Metamaterials 2019
With the paper Y. Radi, A. Alù, “Nonreciprocal Metagratings”
- Sep. 15, 2019:** 2019 Highly Cited Researcher
Clarivate Analytics Web of Science
Highly Cited Researchers earn this distinction because, during the previous decade, they produced multiple highly cited papers. These are defined as papers ranking in the top 1% by citations, considering both year and field of publication.
- June 24, 2019:** IEEE Kiyoo Tomiyasu Award
IEEE Geoscience and Remote Sensing Society, IEEE Microwave Theory and Techniques Society
‘For contributions to novel electromagnetic materials and their application’
The IEEE Kiyoo Tomiyasu Award was established in 2001 to recognize outstanding early to mid-career contributions to technologies holding the promise of innovative applications. Recipient selection is administered through the Technical Field Awards Council of the IEEE Awards Board. The award consists of a bronze medal, certificate, and a 10k\$ honorarium.
- June 21, 2019:** IET A F Harvey Prize Engineering Research Prize (Finalist)
Institute of Engineering and Technology
The prize is awarded annually in recognition of an outstanding achievement in engineering research in the fields of medical, microwave and radar or laser/optoelectronic engineering, with the prize fund (350k GBP) awarded to support further research led by the recipient.
- May 7, 2019:** Blavatnik National Award for Young Scientists (Finalist)
The New York Academy of Sciences – Physical Sciences and Engineering Category
The Blavatnik National Awards honor America’s most innovative young faculty-rank scientists and engineers. These awards celebrate the past accomplishments and future potential of young faculty members working in three disciplinary categories of science and engineering. The Blavatnik National Awards are conferred at a formal ceremony in New York City each fall.
- May 1, 2019:** Vannevar Bush Faculty Fellowship
Department of Defense

The Vannevar Bush Faculty Fellowship (VBFF) is the Department of Defense's most prestigious single-investigator award and supports basic research with the potential for transformative impact. As a 5-year fellowship with up to \$3 million in funding, the VBFF supports new, out-of-the box ideas where researcher creativity intersects with the unknown. Vannevar Bush Fellows represent a cadre of experts that provide invaluable direction to the DoD in its scientific efforts and also train the next generation of scientists and engineers.

- April 8, 2019:** Metamorphose President
Virtual Institute for Artificial Electromagnetic Materials and Metamaterials
- Oct. 1, 2018:** IEEE Antennas and Propagation Society Administrative Committee Member
IEEE AP-S
- Sep. 25, 2018:** IUMRS – MRS Singapore Young Researcher Award 2018
Materials Research Society
- Sep. 5, 2018:** 2018 Highly Cited Researcher
Clarivate Analytics Web of Science
Highly Cited Researchers earn this distinction because, during the previous decade, they produced multiple highly cited papers. These are defined as papers ranking in the top 1% by citations, considering both year and field of publication.
- September 15, 2023:** Sander Mann, ***APS Best Theory Paper Award, Metamaterials 2023***
Maximum Asymmetric Absorption and Scattering in Bianisotropic Particles
- July 18, 2023:** Shixiong Yin, ***Eliasoph Fellowship***
City University of New York
- May 21, 2023:** Adam Overvig, ***Blavatnik Regional Award for Young Scientists (Finalist)***
New York Academy of Sciences
- April 12, 2023:** Yoshiaki Kasahara, ***USNC-URSI Student Paper Award (Honorable Mention)***
Dispersion Engineered Nonlocal Metasurfaces with Customizable Wavefront-Selectivity
- January 10, 2023:** Shixiong Yin, ***USNC-URSI Student Paper Award (3rd Place)***
Temporal Scattering at Passive Time-Interfaces
- January 5, 2023:** Shixiong Yin, ***IEEE Antennas and Propagation Society Doctoral Research Grant***
- October 15, 2022:** Gengyu Xu, ***2022 Antennas and Propagation Society (AP-S) Postdoctoral Fellowship***, IEEE AP-S
- September 15, 2022:** Seunghwi Kim, ***Best Experimental Paper Award (1st Prize)***, Metamaterials Conference
Virtual Excitations Enhance the Resolution of Metamaterial Superlenses
- July 14, 2022:** Yoshiaki Kasahara, ***IEEE AP-S Student Paper Competition (1st Prize)***, IEEE AP-S URSI Conference
Chiral Nonlocal Metasurfaces for Frequency-Selective Wavefront Shaping

- December 20, 2020: Diego Farfan, *URSI-USNC Student Paper Contest (3rd place)*, National Radio Science Meeting
Radio-Transparent Dielectric Core Metasurface Antenna
- December 20, 2020: Yoshiaki Kasahara, *URSI-USNC Student Paper Contest (Finalist)*, National Radio Science Meeting
Hybrid Lens with Near Unitary Numerical Aperture in Transmissive Mode

XV. Concluding remarks and plans forward

During the past five years, we have made important and remarkable progress towards our vision of magnet-free non-reciprocal devices enabled by time-modulated metamaterials, both for radio-frequencies and for nanophotonics. Our research work has been presented in a total of 228 journal papers. Many of these papers have appeared in extremely competitive scientific journals, including *Nature* and *Science*, highlighted in covers and picked by the editors as top papers, and have been presented in literally hundreds of talks at international conferences and seminars, including several plenary, keynote and invited talks. Many of our PIs and team members have been recognized with important awards and honors also, as a testimony of the quality of research we are carrying forward. Several of our inventions have been patented and transitioned to more applied programs and commercial endeavors. Several of our supported students and postdocs have moved forward to successful careers in academia, industry and government laboratories.

One of the most significant outcomes of this MURI program has been the jumpstart of totally new research fields, that could not have been envisioned at the time of the proposal. Among these, our program has showcased the first metamaterial demonstrating time-reflections of electromagnetic waves, which has been opening a path towards time and space-time metamaterials, the first Floquet nonreciprocal topological insulator for mm-waves, with groundbreaking opportunities for wireless communications, and new material platforms for photonic nonreciprocal technologies. Our joint team efforts have put forward new technologies relevant to radio-wave, mm-wave and nanophotonic technologies, and both for free-space and guided-wave devices, and new concepts, such as synthetic dimensions and complex-frequency excitations. We look forward to successful transitions to industry and government of our inventions and discoveries, and we foresee an exciting future for time-modulated metamaterials.