

AD/A-002 011

STATISTICAL ANALYSIS OF A CLASS OF IF CORRELATOR:
FM RANGING SYSTEMS

Marion C. Bartlett, et al

Florida University

Prepared for:

Harry Diamond Laboratories

October 1974

DISTRIBUTED BY:

NTIS

National Technical Information Service
U. S. DEPARTMENT OF COMMERCE

The findings in this report are not to be construed as an official Department of the Army position unless so designated by other authorized documents.

Citation of manufacturers' or trade names does not constitute an official indorsement or approval of the use thereof.

Destroy this report when it is no longer needed. Do not return it to the originator.

ACCESSION FOR	
HTIS	<input checked="" type="checkbox"/>
BDC	<input type="checkbox"/>
UNANNOUNCED	<input type="checkbox"/>
JUSTIFICATION	<input type="checkbox"/>
BY DISTRIBUTION AVAILABILITY CODES	
Dist.	MAIL ROOM OR SPECIAL
A	

11a

REPORT DOCUMENTATION PAGE		READ INSTRUCTIONS BEFORE COMPLETING FORM
1. REPORT NUMBER HDL-TR-039-3	2. GOVT ACCESSION NO.	3. RECIPIENT'S CATALOG NUMBER AD/A-002011
4. TITLE (and Subtitle) STATISTICAL ANALYSIS OF A CLASS OF IF CORRELATOR FM RANGING SYSTEMS		5. TYPE OF REPORT & PERIOD COVERED final January to December 1974
		6. PERFORMING ORG. REPORT NUMBER
7. AUTHOR(s) Marion C. Bartlett Barry G. Mattox		8. CONTRACT OR GRANT NUMBER(s) HDL Contract Number DAAG39-74-C-0039
9. PERFORMING ORGANIZATION NAME AND ADDRESS ENGINEERING & INDUSTRIAL EXPERIMENT STATION UNIVERSITY OF FLORIDA GAINESVILLE, FLORIDA 32611		10. PROGRAM ELEMENT, PROJECT, TASK AREA & WORK UNIT NUMBERS Program element: 6.26.16.A HDL proj: A22400; 101400
11. CONTROLLING OFFICE NAME AND ADDRESS ARMY MATERIEL COMMAND HARRY DIAMOND LABORATORIES WASHINGTON, D.C. 20438		12. REPORT DATE October 1974
		13. NUMBER OF PAGES 45
14. MONITORING AGENCY NAME & ADDRESS (if different from Controlling Office)		15. SECURITY CLASS. (of this report) UNCLASSIFIED
		15a. DECLASSIFICATION/DOWNGRADING SCHEDULE
16. DISTRIBUTION STATEMENT (of this Report) APPROVED FOR PUBLIC RELEASE; DISTRIBUTION UNLIMITED		
17. DISTRIBUTION STATEMENT (of the abstract entered in Block 20, if different from Report)		
18. SUPPLEMENTARY NOTES Sponsor: AMC/ARMCOM. Work unit title: Fuze technology DA-1W662616AH77, AMCMS Code: 662616.11.H7700		
19. KEY WORDS (Continue on reverse side if necessary and identify by block number) FM Ranging IF Correlation Hybrid Modulation Reproduced by NATIONAL TECHNICAL INFORMATION SERVICE U.S. Department of Commerce Springfield, VA. 22151		
20. ABSTRACT (Continue on reverse side if necessary and identify by block number) A statistical analysis technique for obtaining range response of IF-correlator FM ranging systems is described under the assumptions of slowly varying, high-index frequency modulation and small propagation delays. It is shown that the range response for a system is determined by the functional relationship between modulation and reference and the envelope of the transmitted power spectrum, which (under the high-index FM assumption) is proportional to the first-order probability density of the modulation. Since		

UNCLASSIFIED

SECURITY CLASSIFICATION OF THIS PAGE(When Data Entered)

statistical techniques are used, time/frequency domain analysis of the IF signal is not required and FM/FM systems or systems which use random modulations are conveniently analyzed. The range response is derived in terms of a sum of weighted quasi-autocorrelation functions which have been translated along the delay axis. The displacements and weightings depend on the harmonic series which describes the IF reference as a function of the frequency modulation. The analysis technique is illustrated with examples of systems designed for low-height ranging applications. Calculated and measured results are shown for simple hybrid modulation/demodulation systems synthesized using the techniques described in the report. These systems feature power spectra which yield well defined range responses and may employ FM/FM techniques to reduce the frequency ambiguities inherent in harmonic systems.

TABLE OF CONTENTS

	Page No.
DD FORM 1473	1
1. INTRODUCTION	5
2. IF CORRELATOR FM RANGING SYSTEM DESCRIPTION	7
3. STATISTICAL DESCRIPTION OF SIGNALS AND REFERENCES	8
3.1 Signal Description	8
3.2 Transition From Time Averaging to Statistical Averaging	10
3.3 Description of $R(\theta)$	12
3.3.1 Determination of $R(\theta)$ from $r(t)$ and $\theta(t)$	12
3.3.2 Choice of τ_0	15
3.3.3 Series Expansion of $R(\theta)$	16
4. STATISTICAL ANALYSIS OF IF CORRELATORS	17
5. EXAMPLES OF MAPPING AND ANALYSIS	18
6. HYBRID MODULATION SYSTEMS AND TEST RESULTS	32
7. CONCLUSIONS	33
REFERENCES	43
DISTRIBUTION	44

LIST OF FIGURES

1. IF Correlator FM Ranging System	7
2. IF Correlator Partial Diagrams	10
3. Monotonic Modulation Sections	11
4. Graphical Mapping of $r(t)$ to $R(\theta)$	13
5. The Multi-Valued Mapping Case	14
6. Illustration of Assignment of τ_0	15
7. Hard-Limited Replica Reference	21
8. Quasi-Replica Reference for Sinusoidal Modulation	22
9. Triangular Modulation with Sinusoidal Reference	23
10. Elimination of Third-Harmonic Response by Reference Phasing	25
11. J_1 Ranging System	26
12. Hybrid Modulation Systems	29

13.	Hybrid System With Null at $\tau = 1/\Delta B$	31
14.	System 1 Block Diagram	34
15.	System 1 Graphical Mapping Diagram	34
16.	System 1 Computed Range Response	35
17.	System 1 Measured Range Response	35
18.	System 2 Block Diagram	36
19.	System 2 Graphical Mapping Diagram	36
20.	System 2 Computed Range Response	37
21.	System 2 Measured Range Response	37
22.	System 3 Block Diagram	38
23.	System 3 Graphical Mapping Diagram	38
24.	System 3 Computed Range Response	39
25.	System 3 Measured Range Response	39
26.	System 4 Block Diagram	40
27.	System 4 Graphical Mapping Diagram	40
28.	System 4 Computed Range Response	41
29.	System 4 Measured Range Response	41
30.	CW Range Response Showing Transmission Line Attenuation	42

STATISTICAL ANALYSIS OF A CLASS
OF IF CORRELATOR FM RANGING SYSTEMS

1. INTRODUCTION

This report describes a statistical technique for analyzing a class of FM ranging systems called "IF Correlators." IF correlators are defined as systems which correlate the IF signal which results from a target at delay time τ with a locally generated reference which is an estimate to the IF signal expected at $\tau = \tau_r$, where τ_r is a reference delay. The range response of IF correlators maximizes near $\tau = \tau_r$ and will have range resolution determined by the transmitted RF bandwidth B. The IF correlation technique has been considered for a variety of ranging applications. References [1-7] analyze various aspects of these systems.

The approach generally used for analyzing IF correlators is to describe the IF signal $s(t)$ and reference $r(t)$ as deterministic time functions. The correlator low-pass output is then the DC term resulting from expressing the product $s(t) \cdot r(t)$ in a Fourier (time) series. Target delay τ is treated as a parameter since it is slowly varying; the variation of the correlator output due to varying τ produces the range response. For simple periodic FM modulations the time analysis approach leads readily to useful results; however, this approach is very difficult for IF correlators which use random or periodic FM/FM type modulations [8]. The time analysis also obscures important functional relationships which are time-independent.

The statistical analysis technique described in this report is based on the fact that both the IF signal and reference can be expressed as sinusoidal functions (or a sum of sinusoidal functions) of a common angle θ which is directly related to the instantaneous transmitted frequency. The angle θ is the phase difference between the transmitted and received signals evaluated at a particular time delay τ and, for small delays and slowly varying modulations, is simply the product of the instantaneous radian frequency and delay time τ . The DC value resulting from the product of the signal $S(\theta)$ and reference $R(\theta)$ is found by statistically averaging the product using the probability density of θ , $p(\theta)$. θ is directly related to the instantaneous transmitted frequency; hence, for high-index FM modulation, $p(\theta)$ is directly proportional to the envelope of the transmitted power spectrum. Since $R(\theta)$ and $S(\theta)$ are sinusoidal (or a sum of sinusoids), their product is sinusoidal in θ . Statistically averaging the sinusoids resulting from the product $S(\theta) \cdot R(\theta)$ using $p(\theta)$ (which is related to the power spectrum) is equivalent to Fourier transforming $p(\theta)$. As a consequence, the resulting range response is expressed in terms of the autocorrelation of the transmitted RF signal.

The statistical technique depends on a time-independent description of the signal and reference as a function of the angle θ and is therefore applicable to random, FM/FM, and periodic modulations with equal facility. Moreover, it provides a unifying concept for analyzing and comparing the variety of systems described in the cited references by demonstrating that all IF correlator systems which have the same modulation/reference statistics will have the same range responses. This fact is by no means apparent using time domain techniques since equivalent systems may appear quite different.

The statistical approach has proven useful for the design and analysis of a variety of IF correlator FM ranging systems. In most cases, nearly optimum systems can be designed using simple graphical techniques and their range responses expressed in closed form. This technique shows that all IF correlators (harmonic N systems, etc.) are directly related to IF replica correlators which use an RF delay line/mixer to produce an IF replica. (A replica is an exact copy of the IF signal expected from an ideal target at $\tau = \tau_r$.) It also demonstrates that any IF reference can be expressed in terms of replicas and the range response expressed in terms of weighted displaced autocorrelation functions. The weighting and displacements are related to the Fourier series which defines the reference R as a function of θ ; the autocorrelation function is found by transforming $p(\theta)$.

The statistical averaging technique used is quite general and is dependent only on an assumption of ergodicity (the equivalence of time and statistical averaging) which is satisfied (approximately) for most physical systems. To simplify the analyses to follow, certain assumptions which are reasonable for the class of FM ranging systems being investigated will be made. First, high-index FM modulation of the oscillator, with no incidental AM, is assumed. For this case, the envelope of the transmitted power spectrum will be directly proportional to the probability density of the frequency modulation. Second, a linear voltage-to-frequency FM modulation characteristic is assumed. It then follows that the probability density of the frequency modulation, and hence the envelope of the transmitted power spectrum, will be directly proportional to the probability density of the modulating voltage. Third, the probability density of the modulation, $p(\theta)$, will be assumed to be an even function, implying an even transmitted power spectrum about the center frequency ω_0 . This assumption simplifies the mathematical expression for the autocorrelation function. Fourth, only ranging systems for which the product of the IF center frequency and the target time delay τ_r is small will be considered. With this assumption, certain phase errors can be ignored and the range response analyzed using first-order statistics.

Using the above assumptions, the signal can always be expressed as a single-valued sinusoidal function of θ . For IF correlators, the reference is necessarily synchronized to the modulation; therefore, the functional relationship $R(\theta)$ is explicitly determined by the hardware implementation. When $R(\theta)$ is not sinusoidal in θ , it can always be expressed in a Fourier series as a weighted sum of sinusoids. For most IF correlators $R(\theta)$ will be a single-valued function; however, for some systems it will be multi-valued as will be illustrated in the examples. When the reference is multi-valued, the modulation is partitioned into discrete monotonic sections for which the reference is single-valued. The system range response may then be computed by summing the range responses due to each monotonic section; alternatively, a composite $R(\theta)$ can be determined by averaging the multiple values according to their probabilities. The system range response is then expressed in terms of the autocorrelation function obtained from the Fourier transform of the total transmitted power spectrum.

Section 2 describes IF correlator FM ranging systems and presents some background material. Section 3 describes the IF signal and reference in statistical terms and presents the necessary justification for the transition from time to statistical averaging. Section 4 derives the range response using the statistical descriptions of Section 3. Section 5 describes a procedure for computing the range response using the statistical technique. This procedure is used to compute the

range response for numerous examples which are chosen to illustrate the major concepts presented in the report. Section 6 presents several simple hybrid modulation systems which were used to obtain test results and compares computed and measured range responses. Section 7 presents the conclusions.

2. IF CORRELATOR FM RANGING SYSTEM DESCRIPTION.

Systems are described by the block diagram of Figure 1, which shows a single antenna configuration and envelope detection of the composite RF voltage at the antenna. Normalized signals, references, autocorrelations, etc., will be used to simplify the analysis. The output of practical systems will, of course, vary with signal amplitudes, mixer gain coefficients, etc.

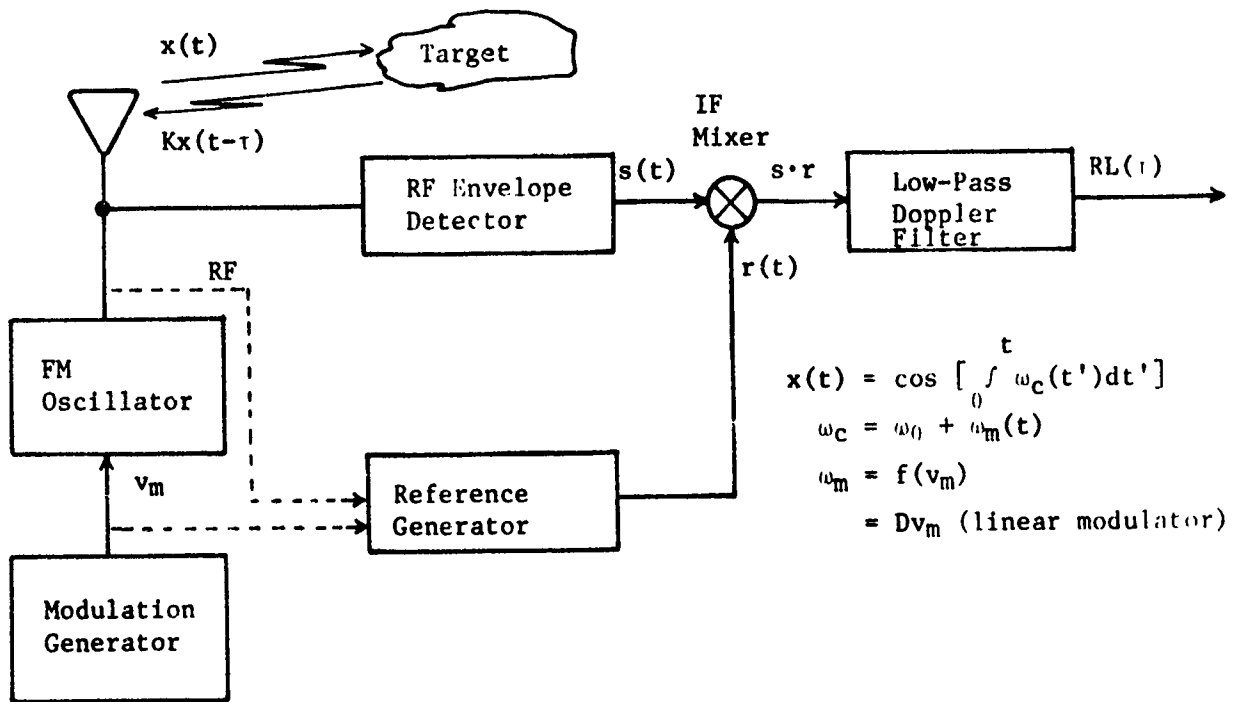

Figure 1: IF Correlator FM Ranging System

The IF signal $s(t)$ is multiplied by a reference $r(t)$ and the product filtered (time-averaged) to obtain the range response $RL(\tau)$. $RL(\tau)$ can be written as the product of an amplitude factor usually called the range law and a sinusoidal doppler carrier. Variations in target delay τ will cause variations in RL at doppler frequencies which are much lower than the modulation/demodulation-system and RF-carrier frequencies; therefore, τ can be considered a slowly varying parameter in the analysis to follow.

Figure 1 illustrates that the reference may be related to the modulation in two ways. First, the reference may be derived from the RF signal using a technique

which is equivalent to the RF delay line/mixer described by Peperone [1]. For this case, the reference will have information about oscillator center frequency ω_0 as well as the varying component $\omega_m(t)$. A reference of this type (replica) is a proper IF reference for all modulations and time delays and is not dependent on a linear FM characteristic. For slowly varying modulations and short time delays, the range response of an IF replica correlator is given by

$$RL(\tau) = R_0(\tau - \tau_r) + R_0(\tau + \tau_r) \quad (2.1)$$

where $R_0(\tau)$ is the autocorrelation of the transmitted RF signal and τ_r is the reference delay.

The above result is important because it demonstrates that the range response of IF correlators can be expressed in terms of a statistical property of the signal (autocorrelation) and is therefore not dependent on the exact time history of the signal and reference. Following discussions will demonstrate that any reference can be expressed in terms of replica references and the range response expressed in terms of autocorrelation functions; therefore, any IF correlator can be analyzed by the statistical techniques appropriate for IF replica correlators.

For many systems (harmonic N systems, for example) the reference is derived directly from the modulation circuitry. Simple systems of this type are usually dependent on a linear modulator characteristic. If the modulator is linear, a reference can be generated which differs from a replica reference only by a phase constant (due to the fact that the modulator has no information about oscillator center frequency ω_0). The phase constant has no practical effect on the range response since it appears as a doppler phase angle. However, the range response is not strictly a displaced autocorrelation function since the doppler carrier will not peak at the same point as the range law. References which differ from replicas only by a phase constant will be called quasi-replicas; the range responses which result from these references will be called quasi-autocorrelation functions.

3. STATISTICAL DESCRIPTION OF SIGNALS AND REFERENCES

This section describes the signal and reference in terms of θ and discusses the transition from time to statistical averaging. A graphical technique for determining $R(\theta)$ is described including a discussion of the procedure to be followed when the reference is not a single-valued function of θ .

3.1 Signal Description

A constant-amplitude angle-modulated carrier can be represented as

$$x(t) = \cos \theta_1(t) \quad (3.1)$$

where $\theta_1(t) = \int_0^t \omega_c(\lambda) d\lambda$ and ω_c is the instantaneous frequency. It is convenient to describe ω_c as the sum of a constant center frequency ω_0 and a varying component $\omega_m(t)$. $\theta_1(t)$ then becomes

$$\theta_1(t) = \int_0^t \omega_0 d\lambda + \int_0^t \omega_m(\lambda) d\lambda = \omega_0 t + \int_0^t \omega_m(\lambda) d\lambda \quad (3.2)$$

A delayed return signal can be written as

$$x(t-\tau) = \cos[\theta_1(t-\tau)] \quad (3.3)$$

where τ is the delay time. $\theta_1(t-\tau)$ is given by

$$\begin{aligned} \theta_1(t-\tau) &= \int_0^{t-\tau} \omega_0 d\lambda + \int_0^{t-\tau} \omega_m(\lambda) d\lambda \\ &= \omega_0 t - \omega_0 \tau + \int_0^{t-\tau} \omega_m(\lambda) d\lambda \end{aligned} \quad (3.4)$$

The IF signal is obtained from some process (envelope detection, etc.) which is equivalent to multiplying $x(t)$ by $x(t-\tau)$ and low-pass filtering the double frequency terms to obtain the lower sideband. The IF signal is then given by

$$\begin{aligned} s(t) &= \cos[\theta_1(t) - \theta_1(t-\tau)] \\ &= \cos\left[\omega_0 \tau + \int_{t-\tau}^t \omega_m(\lambda) d\lambda\right] \end{aligned} \quad (3.5)$$

Expanding $\int_{t-\tau}^t \omega_m(\lambda) d\lambda$ in a Taylor series about $\tau = 0$ gives

$$\int_{t-\tau}^t \omega_m(\lambda) d\lambda = \omega_m(t)\tau - \frac{\dot{\omega}_m(t)\tau^2}{2} + \dots \quad (3.6)$$

For many ranging systems, the phase error represented by $\frac{\dot{\omega}_m(t)\tau^2}{2} + \dots$ is small and the signal phase is adequately represented by the angle $(\omega_0 + \omega_m(t))\tau$. The signal can then be written as

$$s(t) = \cos[\omega_c(t)\tau] = \cos[\omega_m(t)\tau + \omega_0\tau] \quad (3.7)$$

The signal is now seen to be a function of the angle $\omega_c\tau$ without regard to the time history of ω_c . The modulation angle θ is defined as

$$\theta \triangleq \omega_m\tau_0 \quad (3.8)$$

where τ_0 is a chosen reference delay (to be discussed later).

The signal can now be written in terms of θ as

$$S(\theta) = \cos\left[\omega_0\tau + \theta \frac{\tau}{\tau_0}\right] \quad (3.9)$$

3.2 Transition From Time Averaging to Statistical Averaging

IF correlator systems may be represented by the partial block diagram of Figure 2(a).

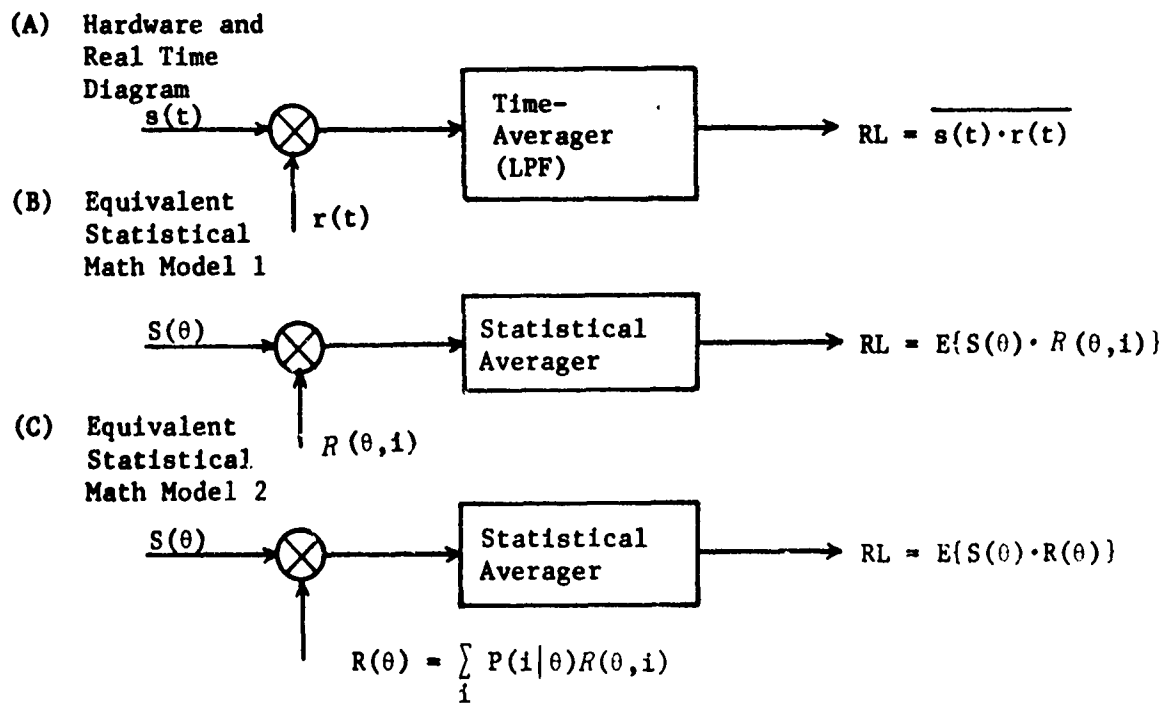

Figure 2: IF Correlator Partial Diagrams

The signal and reference waveforms are multiplied and time-averaged by the filter to yield the range response

$$RL = \overline{s(t)r(t)} \quad (3.10)$$

In order to treat periodic systems by statistical methods, it is useful to treat time as a random variable and all functions of time as transformations of the random variable t . A suitable representation of t is that of a uniformly distributed random variable with probability density

$$p(t) = \begin{cases} \frac{1}{T} & , \quad \frac{T}{2} < t < \frac{T}{2} \\ 0 & , \quad \text{otherwise} \end{cases} \quad (3.11)$$

Thus we may replace all time averages by ensemble averages:

$$E\{s(t)r(t)\} = \int_{-T/2}^{T/2} s(t)r(t) \frac{1}{T} dt = \overline{s(t)r(t)} \quad (3.12)$$

This relation reflects an assumption of ergodicity of the processes; i.e., the time average equals the ensemble average.

Now consider a general periodic modulation consisting of a number of monotonic sections as shown in Figure 3. We denote the sections by index i and their length in time by T_i . Now, if we define a function θ to be

$$\theta = g_1(t) = g(\omega_m(t)) = \omega_m(t)\tau_0 \quad (3.13a)$$

where g is a functional of ω_m and τ_0 is a chosen delay, and since i is also a function of t ,

$$i = g_2(t) \quad (3.13b)$$

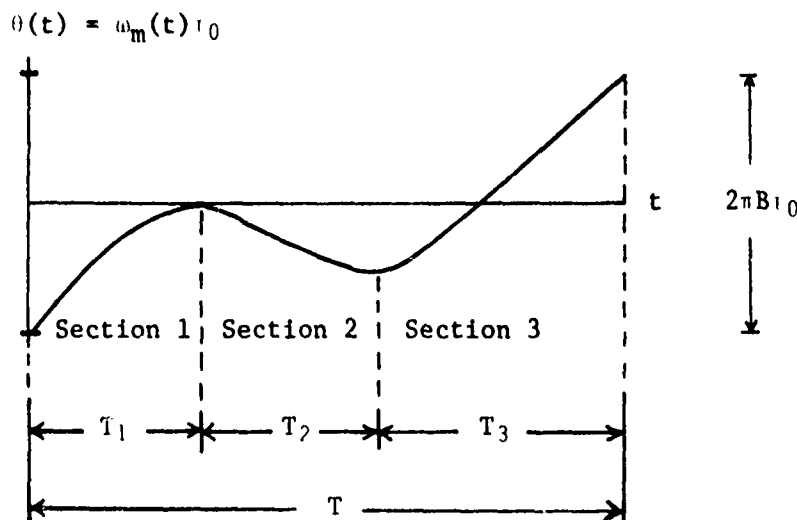

Figure 3: Monotonic Modulation Sections

then there is a one-to-one correspondence between the two sets $\{t\}$ and $\{i\}$ such that, using the transformation of variables by equation (3.13), $p(t)$ maps into the joint probability density $p(\theta, i)$ and vice versa. It is seen from equation (3.9) that the signal $S(\theta)$ is not a function of i . The reference may also be written in terms of θ , but the reference, $R(\theta, i)$, is, in general, also a function of i . It is clear that we may now average with respect to any statistic in which the argument

of the average is expressed.

$$E\{s(t)r(t)\} = E\{S(\theta)R(\theta, i)\} \quad (3.14)$$

where we have indicated that the signal and reference may be expressed in either domain by a transformation of variables. Figure 2(b) illustrates this notation. Now

$$E\{S(\theta)R(\theta, i)\} = \int S(\theta) \left[\int R(\theta, i) p(\theta, i) di \right] d\theta \quad (3.15a)$$

Since the joint density $p(\theta, i)$ is that of a continuous variable θ and a discrete variable i , integration with respect to i gives

$$\begin{aligned} E\{S(\theta)R(\theta, i)\} &= \int S(\theta) \left[\sum R(\theta, i) P(i|\theta) \right] p(\theta) d\theta \\ &= \int S(\theta) R(\theta) p(\theta) d\theta \\ &= E\{S(\theta)R(\theta)\} \end{aligned} \quad (3.15b)$$

where $R(\theta)$ can be considered a composite reference described by

$$R(\theta) \triangleq \sum_i R(\theta, i) P(i|\theta) \quad (3.16)$$

$P(i|\theta)$ is the conditional probability of the discrete random event i .

We may now equivalently show the variables as in Figure 2(c). The description of S and R in terms of θ will be used in the statistical methods described in this report. Equation (3.15) shows that any expression for $R(\theta)$ which is correct over the modulation interval bounded by $p(\theta)$ will give the same range response. However, the mathematical form of the results may appear quite different since various representations of $R(\theta)$ which are equivalent over the modulation interval may be quite different beyond that interval. This point is illustrated in an example to follow.

3.3 Description of $R(\theta)$

3.3.1 Determination of $R(\theta)$ from $r(t)$ and $\theta(t)$

As noted previously, the relationship between the reference and the modulation is determined explicitly by the hardware implementation and can be written analytically if desired. However, a simpler graphical technique can be used to determine $R(\theta)$ when $r(t)$ and $\theta(t) = \omega_m(t)\tau_0$ are known. The linear modulator characteristic is assumed so that ω_m is linearly proportional to the modulation voltage v_m as given by $\theta = Dv_m\tau_0$. A visual display of the functional relationship $R(\theta)$ can be obtained by connecting $r(t)$ to the y-axis and $\theta(t)$ to the x-axis of an oscilloscope and observing the Lissajous figure which results. Alternately, a graphical transfer

function approach can be used where $\theta(t)$ and $r(t)$ are plotted and $\theta(t)$ used to map $r(t)$ into $R(\theta)$. The approach is illustrated in Figure 4 with triangle modulation and a sinusoidal reference. $r(t)$ is written

$$r(t) = \cos \frac{2\pi}{T} t \quad (3.17)$$

and $R(\theta)$ is written most simply as

$$R(\theta) = \cos \left(\theta - \frac{\pi}{2} \right) \quad (3.18)$$

where the range of θ is obviously π , implying that $B\tau_0 = 1/2$, where B is the peak-to-peak RF bandwidth in Hz. More formal mapping procedures can be defined but are not necessary for analyzing the systems described here.

It is apparent from Figure 4 that $R(\theta)$ does not depend on time period T ; therefore, this system may be period-modulated as in an FM/FM type system without changing $R(\theta)$ or the range response if $r(t)$ and $\theta(t)$ are generated by methods which do not change their functional relationship when modulated. Multiple-output function generators which may be frequency-modulated represent such systems.

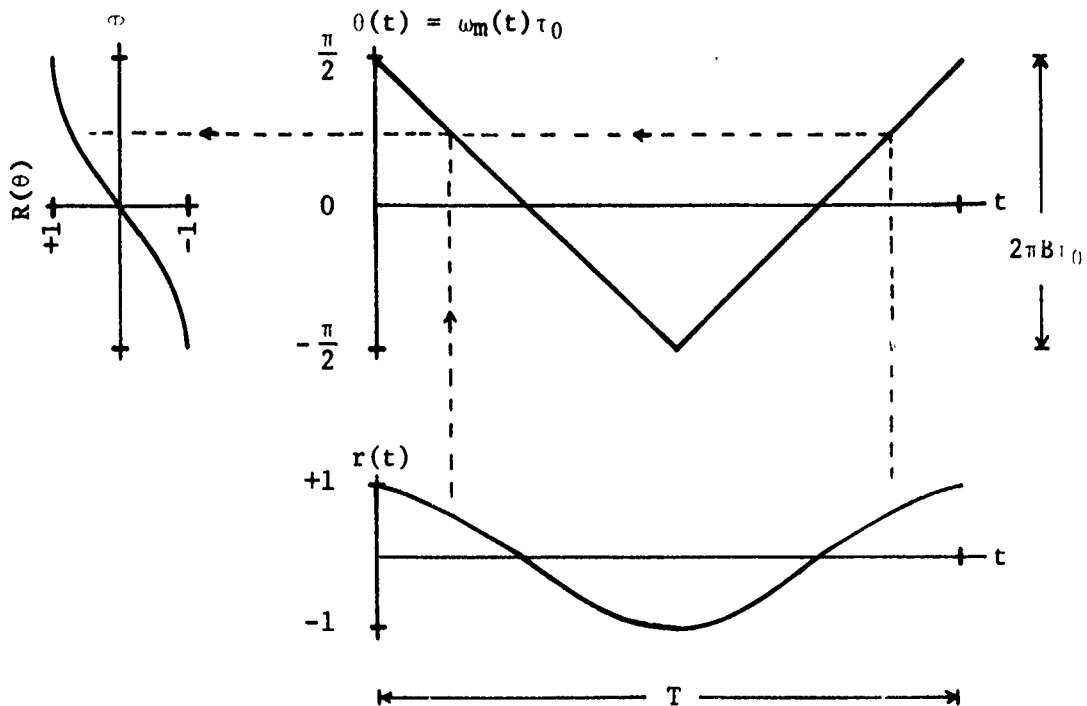

Figure 4: Graphical Mapping of $r(t)$ to $R(\theta)$

For the previous example, a given value of θ corresponded to a single value of $r(t)$. A replica reference always has this one-to-one relationship; however, an arbitrary modulator/demodulator system may not produce such a unique (i.e., one-to-one) relationship. For such cases, we perform the mapping procedure for the separate monotonic sections of the modulation ($\omega_m(t)$ or $\theta(t)$) to produce a set of references $\{R(\theta,i)\}$ where i refers to the modulation section. To illustrate this, consider the previous example with a reference phase of 90 degrees (Figure 5). The range response of this system will be zero since the reference is not phased properly (time domain) with respect to the modulation. It is seen that the first section of $\theta(t)$ maps positive values of $r(t)$ into $R(\theta,1)$ while the second section maps negative values of $r(t)$ into $R(\theta,2)$. To carry out the analysis indicated for cases of this type, a single, composite $R(\theta)$ is determined; the functions $R(\theta,i)$ are simply averaged with respect to i to yield $R(\theta)$. According to Section 2.2, we form this average as

$$R(\theta) = \sum_i P(i|\theta)R(\theta,i) \quad (3.19)$$

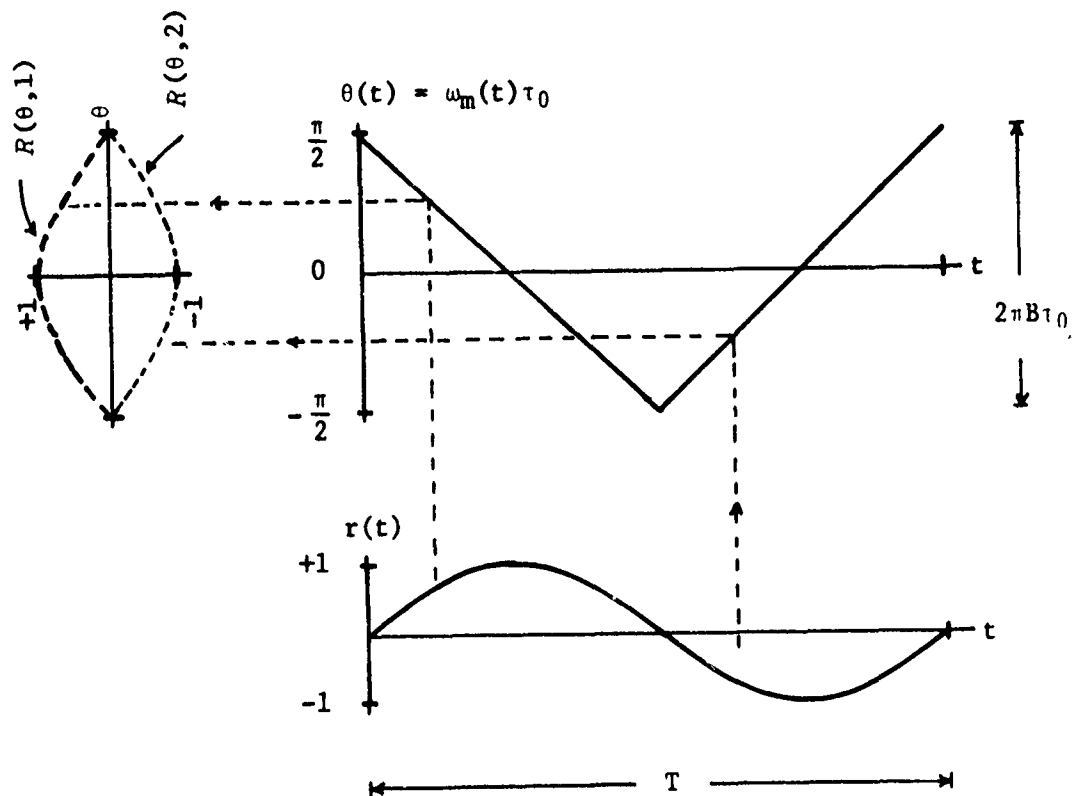

Figure 5: The Multi-Valued Mapping Case

It is easy to show that, in general, the (discrete, conditional) probability of the i th modulation section is found as

$$P(i|\theta) = \frac{|S_i^{-1}(\theta)|}{\sum_j |S_j^{-1}(\theta)|} \quad (3.20)$$

where $S_k = \frac{d}{dt} \theta(t)$ is the slope of the k th section of $\theta(t) = \omega_m(t)\tau_0$ at the ordinate θ (and is, in general, a function of θ); the summation of the denominator is taken over those sections which pass through the ordinate θ .

For the current example $|S_1| = |S_2|$ and thus $P(1|\theta) = P(2|\theta) = 1/2$. As expected

$$R(\theta) = \frac{1}{2} R(\theta,1) + \frac{1}{2} R(\theta,2) = 0 \quad (3.21)$$

Since the composite reference is zero, the system will have no range response as expected.

3.3.2 Choice of τ_0

The constant τ_0 used to define $\theta = \omega_m \tau_0$ is a scaling parameter which determines the periodic interval for expanding $R(\theta)$ in a Fourier series. τ_0 is chosen so that $R(\theta)$ may be represented in the most concise cosine series that represents $R(\theta)$ in the modulation interval. This is generally accomplished by defining the smallest angular interval over which the reference is periodic to be from $-\pi$ to π radians (Figure 6)

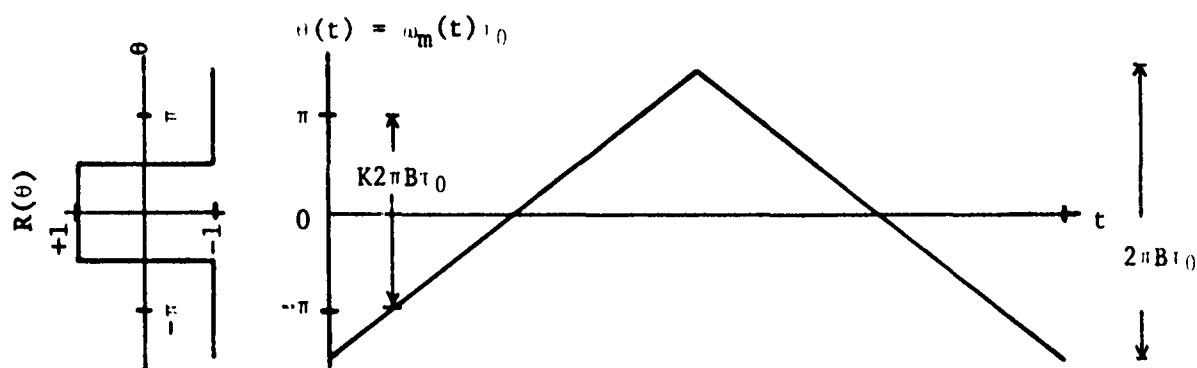

Figure 6: Illustration of Assignment of τ_0

Note that the total modulation angle $2\pi B\tau_0$ may be less than or greater than 2π . In some cases it may be helpful and completely valid to extend the definition of

$R(\theta)$ beyond the modulation interval to obtain a simple representation of $R(\theta)$. The ratio K of the interval chosen as $\pm\pi$ to the modulation interval $\pm\pi B\tau_0$ defines τ_0 as

$$\tau_0 = \frac{1}{KB} \quad (3.22)$$

A replica reference for time delay τ_r is defined by

$$R(\theta) = S(\theta) \Big|_{\tau=\tau_r} = \cos\left(\omega_0\tau_r + \frac{\theta\tau_r}{\tau_0}\right) \quad (3.23)$$

It is evident that for this case τ_0 should be chosen as $\tau_0 = \tau_r$. A poor choice of τ_0 will still yield the correct range response but will require that more terms be summed to give the same results. The examples to follow will clarify the choice of τ_0 .

3.3.3 Series Expansion of $R(\theta)$

To facilitate the following analyses $R(\theta)$ is expanded in a harmonic cosine series. Having defined the periodic interval as described in the previous section, $R(\theta)$ can be written as

$$R(\theta) = \sum_{n=0}^{\infty} C_n \cos(n\theta + \phi_n) \quad ; \quad -\pi B\tau_0 < \theta < \pi B\tau_0 \quad (3.24)$$

where B is the peak-to-peak frequency deviation in Hz,

$$C_n = \sqrt{A_n^2 + B_n^2} \quad , \quad \phi_n = \tan^{-1} \left(\frac{-B_n}{A_n} \right)$$

$$A_0 = \frac{1}{2\pi} \int_{-\pi}^{\pi} R(\theta) d\theta \quad , \quad A_n = \frac{1}{\pi} \int_{-\pi}^{\pi} R(\theta) \cos n\theta d\theta$$

$$B_n = \frac{1}{\pi} \int_{-\pi}^{\pi} R(\theta) \sin n\theta d\theta \quad .$$

The series is the sum of quasi-replicas.

A series of harmonic replicas would be written as

$$R(\theta) = \sum_{n=0}^{\infty} C_n \cos[n\theta + n\omega_0\tau_0] \quad (3.25)$$

The quasi-replica is distinguished from the replica in that, in general, $\phi_n \neq n\omega_0\tau_0$ since quasi-replicas are independent of center frequency, ω_0 .

4. STATISTICAL ANALYSIS OF IF CORRELATORS

Equation (3.15) provides the basis of statistical analysis. This statistical average may be expressed variously as

$$\begin{aligned} \text{RL}(\tau) &= E\{S(\theta)R(\theta, i)\} = \int S(\theta) \left[\sum_i R(\theta, i) P(i|\theta) \right] p(\theta) d\theta \\ &= \int S(\theta) R(\theta) p(\theta) d\theta \end{aligned} \quad (4.1a)$$

$$\begin{aligned} &= \sum_i P(i) \left[\int S(\theta) R(\theta, i) p(\theta|i) d\theta \right] \\ &= \sum_i P(i) \text{RL}_i(\tau) \end{aligned} \quad (4.1b)$$

The average expressed as in Equation (4.1a) implies that a composite reference $R(\theta)$ is computed as the statistical average (over i) of the reference $R(\theta, i)$ corresponding to the modulation sections. This reference is then used in computing the first-order average with respect to θ . A second expression for the average, equation (4.1b), computes the contribution of the i th modulation section (with the corresponding reference) and then averages the resulting component range responses $\text{RL}_i(\tau)$. In this report we choose the former approach because the range response may then be expressed in terms of the signal autocorrelation function.

The form of Equation (4.1a) shows that systems are equivalent (i.e. yield the same range response) as long as the product $S(\theta) \cdot R(\theta) \cdot p(\theta)$ remains the same. This means that any combination of FM weighting (reflected in $p(\theta)$), AM weighting of the signal envelope (reflected in $S(\theta)$), or weighting in the "receiver" (reflected in $R(\theta)$) may be used to achieve a desired range response.

For the constant-amplitude FM signal case with $R(\theta)$ expanded as a cosine series the (normalized) range response is

$$\text{RL}(\tau) = 2 \int \cos\left(\theta \frac{\tau}{\tau_0} + \omega_0 \tau\right) \sum_n C_n \cos(n\theta + \phi_n) p(\theta) d\theta \quad (4.2a)$$

$$= \sum_n C_n \left\{ \int \cos\left[\theta \left(\frac{\tau}{\tau_0} + n\right) + (\omega_0 \tau + \phi_n)\right] p(\theta) d\theta + \int \cos\left[\theta \left(\frac{\tau}{\tau_0} - n\right) + (\omega_0 \tau - \phi_n)\right] p(\theta) d\theta \right\} \quad (4.2b)$$

$$\begin{aligned} &= \sum_n C_n \left\{ \cos(\omega_0 \tau + \phi_n) \int \cos\left[\theta \left(\frac{\tau}{\tau_0} + n\right)\right] p(\theta) d\theta \right. \\ &\quad - \sin(\omega_0 \tau + \phi_n) \int \sin\left[\theta \left(\frac{\tau}{\tau_0} + n\right)\right] p(\theta) d\theta \\ &\quad + \cos(\omega_0 \tau - \phi_n) \int \cos\left[\theta \left(\frac{\tau}{\tau_0} - n\right)\right] p(\theta) d\theta \\ &\quad \left. - \sin(\omega_0 \tau - \phi_n) \int \sin\left[\theta \left(\frac{\tau}{\tau_0} - n\right)\right] p(\theta) d\theta \right\} \end{aligned} \quad (4.2c)$$

Since $\sin[\theta(\frac{\tau}{\tau_0} \pm n)]$ is an odd function of θ , if the power spectrum is even (i.e. $p(\theta)$ is even), the second and fourth integrals of Equation (4.2c) are zero, simplifying the expression to

$$RL(\tau) = \sum_n C_n \{ \cos(\omega_0 \tau + \phi_n) \int \cos[\theta(\frac{\tau}{\tau_0} + n)] p(\theta) d\theta + \cos(\omega_0 \tau - \phi_n) \int \cos[\theta(\frac{\tau}{\tau_0} - n)] p(\theta) d\theta \} \quad (4.3)$$

The integrals are recognized as Fourier cosine transforms of $p(\theta)$:

$$\int \cos[\theta(\frac{\tau}{\tau_0} \pm n)] p(\theta) d\theta = \rho_0(\tau \pm n\tau_0) \quad (4.4)$$

where

$$\rho_0(\tau) = F^{-1}\{F_0(\omega)\} \quad ,$$

$$F_0(\omega) = 2\pi\tau_0 p(\theta) \text{ with the substitution } \theta = \omega\tau_0$$

and F_0 is the signal power spectrum translated to baseband. Thus the range response becomes

$$RL = E\{SR\} = \sum_n C_n [\rho_0(\tau - n\tau_0) \cos(\omega_0\tau - \phi_n) + \rho_0(\tau + n\tau_0) \cos(\omega_0\tau + \phi_n)] \quad (4.5)$$

Equation (4.5) gives the range response in terms of ρ_0 , doppler phasing ϕ_n , and weighting coefficients C_n . ρ_0 is related to the envelope of the power spectrum of the transmitted signal (translated to baseband) through the Fourier transform; $\{C_n\}$ and $\{\phi_n\}$ are derived from R expressed as a harmonic series in θ .

It is important to realize that, as long as the relationship of R to θ remains unchanged and the RF power spectrum remains the same, then the range response does not change (note the parameters of Equation (4.5)). Therefore, the statistical analysis technique may be used with equal facility for both harmonic, random, and FM/FM type systems.

5. EXAMPLES OF MAPPING AND ANALYSIS

The examples of this section are designed to interrelate various concepts, to give insight into the statistical analysis approach, to contrast that approach with time analysis, and to illustrate the basic method. The examples will follow the following analysis procedure.

Step 1: Determine $R(\theta)$

- (A) By knowledge of $r(t) = \theta(t) = \omega_m(t)\tau_0$, determine $R(\theta)$ or $\{R(\theta, i)\}$. (The graphical mapping procedure will be used in the examples.)
- (B) Average $\{R(\theta, i)\}$ as shown in Section 3 (if the mapping is not one-to-one) to yield $R(\theta)$.

Step 2: Expand $R(\theta)$ into a harmonic cosine series.

Define τ_0 to yield the most concise series.

$$R(\theta) = \sum_{n=0}^{\infty} C_n \cos (n\theta + \phi_n) \quad . \quad (5.1)$$

Step 3: Write the range response.

Assuming an even power spectrum, the response will be

$$RL = \sum_{n=0}^{\infty} C_n [\rho_0(\tau - n\tau_0) \cos (\omega_0\tau - \phi_n) + \rho_0(\tau + n\tau_0) \cos (\omega_0\tau + \phi_n)] \quad . \quad (5.2)$$

The mapping of $r(t)$ into $R(\theta)$ is central to the analysis. The following examples illustrate this mapping and will clarify other features of the statistical approach to the analysis. In most examples, the time histories of $r(t)$ and $\{v_m, \omega_m, \omega_m\tau_0 = \theta\}$ are depicted showing the mapping into $R(\theta, i)$ and thus $R(\theta)$. The probability density $p(\theta)$ is also illustrated, since it determines the envelope of the transmitted power spectrum and thus $\rho_0(\tau)$.

Example 1: IF Replica Correlators

The replica correlator system generates a reference which is an exact copy of the IF signal for $\tau - \tau_r$, where τ_r is the delay for which the response is designed to peak. Thus

$$\begin{aligned} r(t) &= s(t) \Big|_{\tau=\tau_r} = \cos \omega_c(t)\tau_r = \cos [\omega_m(t)\tau_r + \omega_0\tau_r] \\ &= \cos \left[\theta(t) \frac{\tau_r}{\tau_0} + \omega_0\tau_r \right] \quad . \end{aligned} \quad (5.3)$$

We now follow the steps for finding the range response.

Step 1: Write $R(\theta)$.

$$R(\theta) = \cos \left(\theta \frac{\tau_r}{\tau_0} + \omega_0\tau_r \right) \quad .$$

Step 2: Expand $R(\theta)$ in a series.

As mentioned previously, our choice of τ_0 is flexible, and is chosen to give the most concise cosine series for $R(\theta)$. We therefore choose $\tau_0 = \tau_r$ to give

$$R(\theta) = \sum_{n=0}^{\infty} C_n \cos (n\theta + \phi_n)$$

where

$$C_n = 1 \quad , \quad n = 1$$

$$= 0 \quad , \quad \text{otherwise}$$

$$\phi_1 = \omega_0 \tau_r \quad .$$

Step 3: Write the range response.

Using equation (5.2) we write

$$RL = C_1 [\rho_0(\tau - \tau_0) \cos(\omega_0 \tau - \phi_1) + \rho_0(\tau + \tau_0) \cos(\omega_0 \tau + \phi_1)]$$

$$= \rho_0(\tau - \tau_r) \cos \omega_0(\tau - \tau_r) + \rho_0(\tau + \tau_r) \cos \omega_0(\tau + \tau_r) \quad .$$

Comparing the two terms of this response to equation (4.4) we see that the response is the sum of translated autocorrelation functions:

$$RL = R_0(\tau - \tau_r) + R_0(\tau + \tau_r) \quad .$$

This is a characteristic of replica correlators; the doppler maximum coincides with the envelope maximum as in a realizable autocorrelation function.

Example 2: Distorted IF Replica Correlators

A concept instrumental in the present analysis technique is that of harmonic replicas. This example will illustrate the harmonic replica representation for the case of the hard-limiter non-linearity.

Consider a replica generator output which is hard-limited to produce

$$r(t) = \text{sgn} [\cos \omega_c(t) \tau_r] = \text{sgn} [\cos(\theta(t) \frac{\tau_r}{\tau_0} + \omega_0 \tau_r)] \quad .$$

Step 1: Write $R(\theta)$.

$$R(\theta) = \text{sgn} [\cos(\theta \frac{\tau_r}{\tau_0} + \omega_0 \tau_r)]$$

Step 2: Expand $R(\theta)$ in a series.

Setting $\tau_0 = \tau_r$, we have $R(\theta) = \text{sgn} [\cos(\theta + \omega_0 \tau_r)]$. $\cos(\theta + \omega_0 \tau_r)$ and $\text{sgn} [\cos(\theta + \omega_0 \tau_r)]$ are illustrated in Figure 7.

It is apparent from Figure 7 that the square-wave reference may be expanded in a set of replicas harmonically related in θ ; each replica corresponds to a delay of $n\tau_r$. Using (5.1),

$$R(\theta) = \sum_{n=0}^{\infty} C_n \cos(n\theta + n\omega_0 \tau_r)$$

$$C_n = \frac{4}{n\pi} \sin \frac{n\pi}{2} \quad \phi_n = n\omega_0 \tau_r \quad .$$

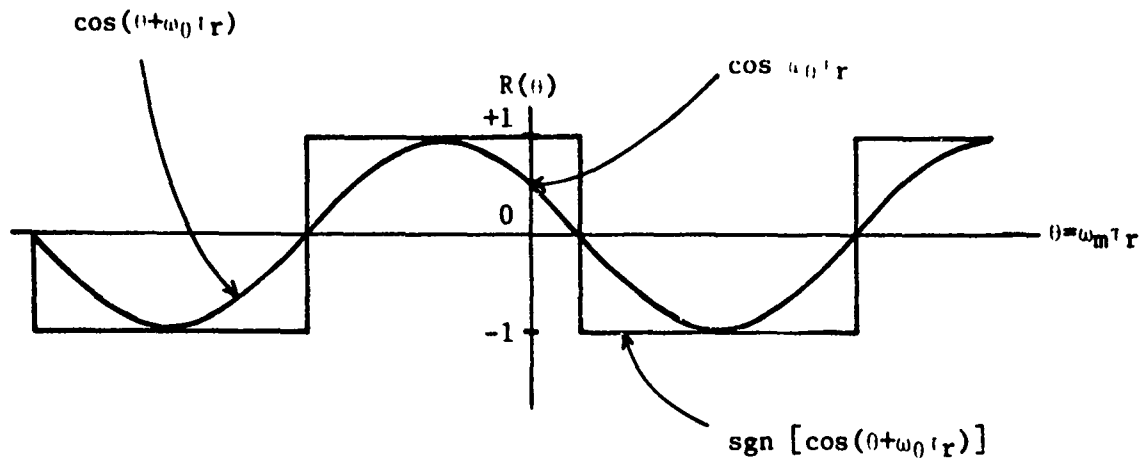

Figure 7: Hard-Limited Replica Reference

Step 3: Using (5.2) the range response is

$$\begin{aligned}
 RL &= \int C_n [\rho_0(\tau - n\tau_r) \cos \omega_0(\tau - n\tau_r) + \rho_0(\tau + n\tau_r) \cos \omega_0(\tau + n\tau_r)] \\
 &= \int C_n [R_0(\tau - n\tau_r) + R_0(\tau + n\tau_r)] .
 \end{aligned}$$

It is important to note that each component of RL has an identical envelope which depends only on the envelope of the transmitted power spectrum; that is, it depends on the probability density of the modulation and not specifically on the modulation waveshape.

We see that the range response of a system which employs a replica which has been distorted by any general zero-memory nonlinearity will consist of the same translated autocorrelation responses as in the above expression; only C_n will vary.

Example 3: Quasi-replica System Using Sinusoidal Modulation

This example is interesting because it demonstrates that, while the time-domain or spectral representation of the reference is complex, its functional description is quite simple. The reference $R(t)$ is assumed to be identical to a replica except for phase. Also, the reference will be assumed to be derived from the modulation voltage rather than the RF carrier (i.e., there are always 4 reference cycles per modulation cycle regardless of RF bandwidth). For this reason, the reference will match the returned signal at a specific value of B rather than τ alone as would be the case for a replica derived from the RF carrier. This distinction holds for all systems which derive the reference from the modulation voltage rather than the RF carrier.

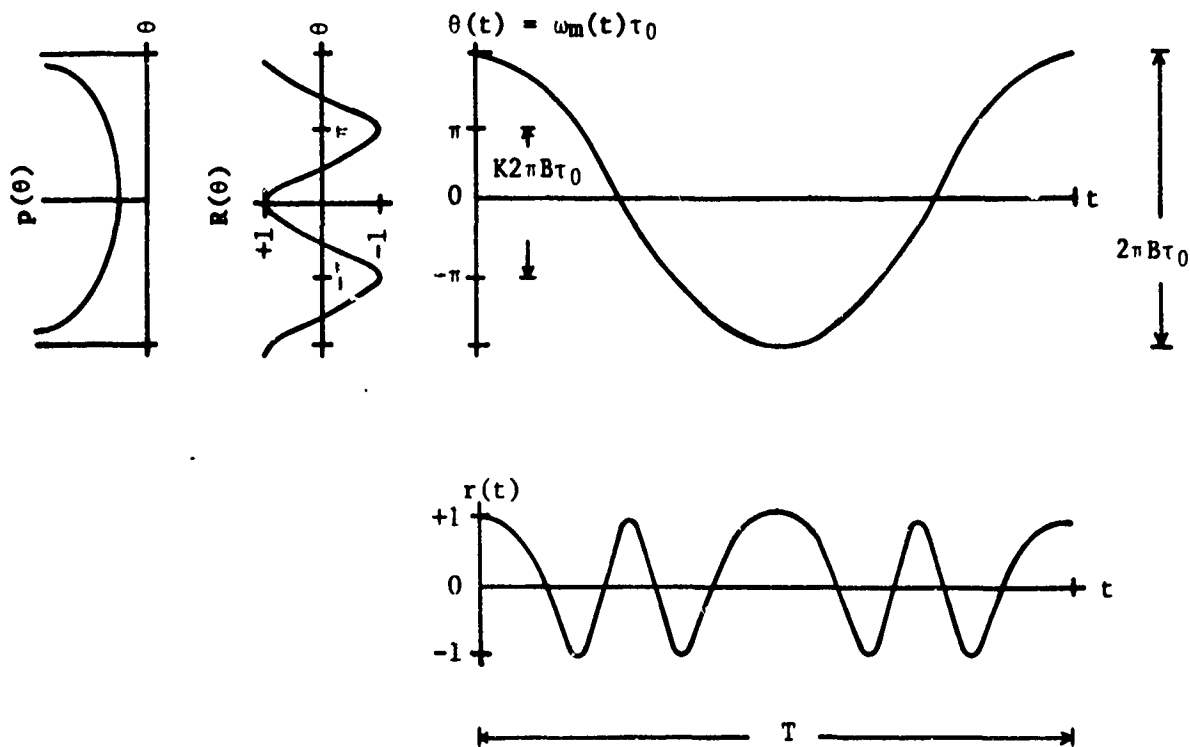

Figure 8: Quasi-Replica Reference for Sinusoidal Modulation

Step 1: The non-uniform time reference $r(t)$, when mapped through $\theta(t)$, yields $R(\theta)$ which is purely sinusoidal.

Step 2: Choosing the smallest periodic interval defines $B\tau_0 = 2$ or $\tau_0 = 2/B$. $R(\theta)$ is described as $R(\theta) = \cos \theta$. Using equation (5.1) $R(\theta)$ is now written in its simplest series with $C_1 = 1$, $C_n = 0$ for $n \neq 1$, and $\phi_n = 0$.

Step 3: Using equation (5.2), the response is written

$$RL = [\rho_0(\tau - \tau_0) + \rho_0(\tau + \tau_0)] \cos \omega_0 \tau$$

where the autocorrelation envelope is found from the power spectrum to be

$$\rho_0(\tau) = J_0(\pi B \tau)$$

Since $\tau_0 = 2/B$, the range response becomes

$$RL = [J_0(\pi[B\tau - 2]) + J_0(\pi[B\tau + 2])] \cos \omega_0 \tau$$

A time analysis of the product $s(t)r(t)$ would have been much more difficult since the contributions due to all harmonics must be summed to give the range response. We see in this example the simplicity of statistical analysis--the transformation to the θ -domain transforms all replicas or quasi-replicas to simple sinusoidal form no matter how formidable they appear in time representation.

Example 4: Triangular Modulation with Sinusoidal Reference

Figure 9 illustrates the system waveforms. This system may be called an $N=2$ harmonic system since

$$r(t) = \cos \left[2 \cdot \left(\frac{2\pi}{T} \right) t \right] .$$

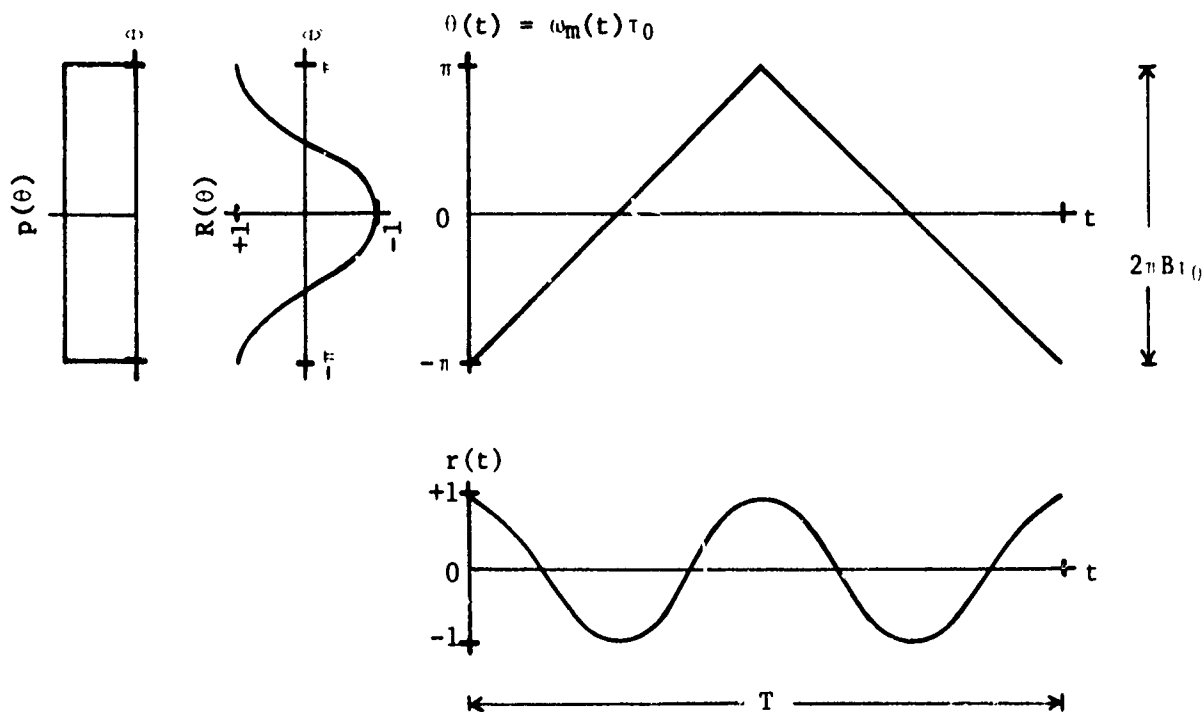

Figure 9: Triangular Modulation with Sinusoidal Reference

Steps 1 and 2: Since $\theta(t)$ is linear and the reference $r(t)$ is sinusoidal, $R(\theta)$ is also sinusoidal. The smallest periodic interval is the total modulation interval so that $B\tau_0 = 1$ or $\tau_0 = 1/B$. Then

$$R(\theta) = -\cos \theta$$

$$C_1 = -1, C_n = 0 : n \neq 1$$

$$\phi_n = 0 .$$

Step 3: Using equation (5.2), the range response becomes

$$RL = C_1 [\rho_0(\tau - \tau_0) + \rho_0(\tau + \tau_0)] \cos \omega_0 \tau .$$

Since the power spectrum is uniform,

$$\rho_0(\tau) = \frac{\sin \pi B \tau}{\pi B \tau}$$

and

$$RL = - \left[\frac{\sin \pi (3\tau - B\tau_0)}{\pi (B\tau - B\tau_0)} \cos \omega_0 \tau + \frac{\sin \pi (B\tau + B\tau_0)}{\pi (B\tau + B\tau_0)} \cos \omega_0 \tau \right]$$

Substituting $\tau_0 = 1/B$ yields

$$RL = - \left[\frac{\sin \pi (B\tau - 1)}{\pi (B\tau - 1)} \cos \omega_0 \tau + \frac{\sin \pi (B\tau + 1)}{\pi (B\tau + 1)} \cos \omega_0 \tau \right]$$

This result can be verified by time analysis.

Example 5: Triangular Modulation with Squarewave Reference

Steps 1 and 2: This example corresponds to Example 4 with the reference defined as

$$r(t) = \text{sgn} \left[\cos \frac{4\pi}{T} t \right] .$$

Thus $R(\theta) = \text{sgn} [-\cos \theta]$, and $\tau_0 = 1/B$ as in Example 4. Using equation (5.1), the squarewave in θ is expanded as

$$R(\theta) = \sum_{n=0}^{\infty} C_n \cos n\theta$$

$$C_n = - \frac{4}{n\pi} \sin \frac{n\pi}{2} .$$

Step 3: Using equation (5.2) the range response is written directly as

$$RL = \cos \omega_0 \tau \sum_{n=1}^{\infty} C_n \left[\frac{\sin \pi (B\tau - n)}{\pi (B\tau - n)} + \frac{\sin \pi (B\tau + n)}{\pi (B\tau + n)} \right]$$

These results are the same as those of Example 4 except for the addition of range responses with displacements and amplitudes according to the terms of the harmonic series for $R(\theta)$.

Example 6: Elimination of Third Harmonic by Reference Phasing

Squarewave references are more economical to generate than sinusoidal references, but they add undesirable range responses due to their harmonic content. Generally, harmonics higher than the third are not troublesome since signal losses combined with lower amplitudes reduce these responses to a tolerable level. Filtering the IF signal to eliminate components corresponding to reference harmonics has been used [5], but this technique requires more circuitry than the phase-shift technique of this example. Shifting the reference with respect to the modulation by 30 degrees achieves a third-harmonic reference phase of 90 degrees, which gives zero third-harmonic range response. All other responses present will be attenuated by 0.866.

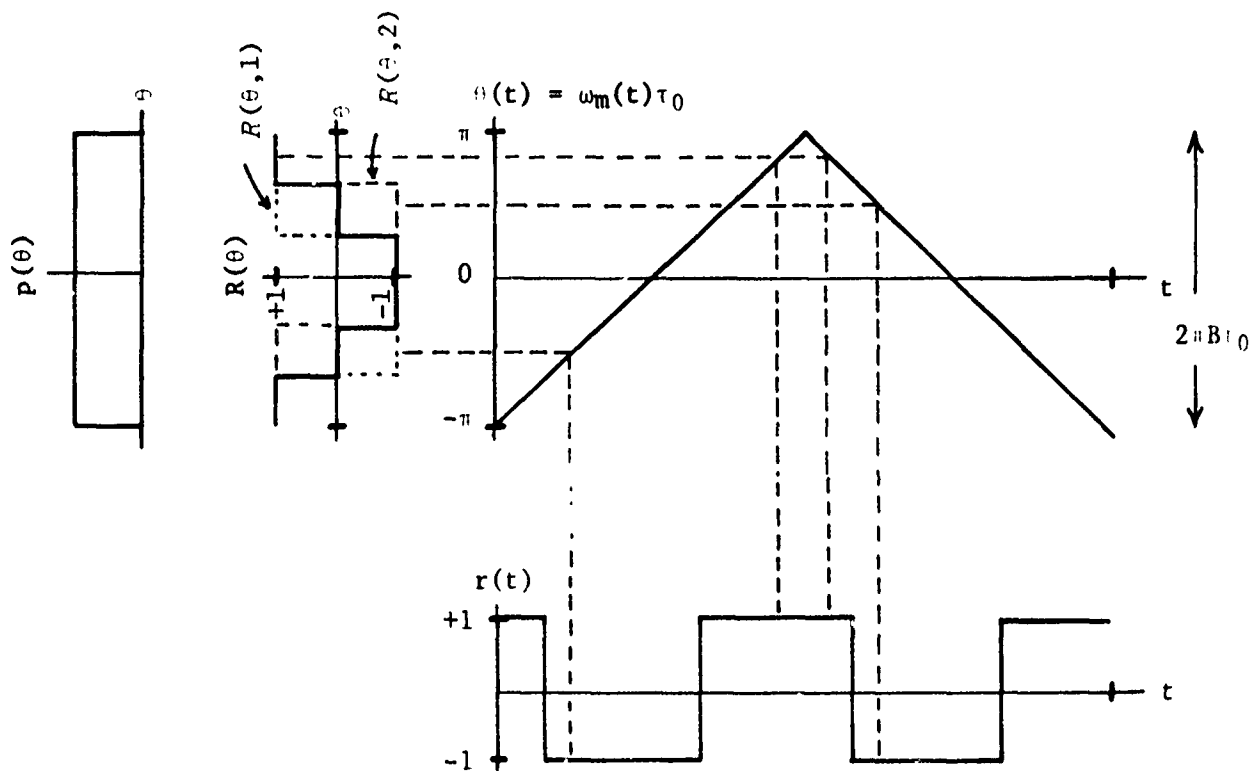

Figure 10: Elimination of Third-Harmonic Response by Reference Phasing

Steps 1 and 2: As shown in Figure 10, the reference averages to zero in the double-valued region (since the weightings of $R(\theta,1)$ and $R(\theta,2)$ are both $1/2$). The reference may be expanded, with $B\tau_0 = 1$, as

$$R(\theta) = \sum_{n=0}^{\infty} C_n \cos n\theta$$

$$C_n = \begin{cases} \frac{-4}{n\pi} \cos \frac{n\pi}{6} & , n \text{ odd} \\ 0 & , n \text{ even} \end{cases}$$

Note that $C_3 = 0$, eliminating the third harmonic of the composite reference, and thus the third harmonic response.

Example 7: J_1 Ranging System

This example demonstrates the corroboration of functional analysis with conventional analyses techniques for the system known to give the range response [9]

$$RL = -2J_1(\pi B\tau) \sin \omega_0\tau$$

This example also demonstrates that the range response can be expressed in various equivalent forms since any expression for $R(\theta)$ which is correct in the modulation interval bounded by $p(\theta)$ can be used. Figure 11 shows the sinusoidal modulation and demodulation in the time domain, along with the linear function $R(\theta)$ and $p(\theta)$ (which describes the envelope of the transmitted power spectrum).

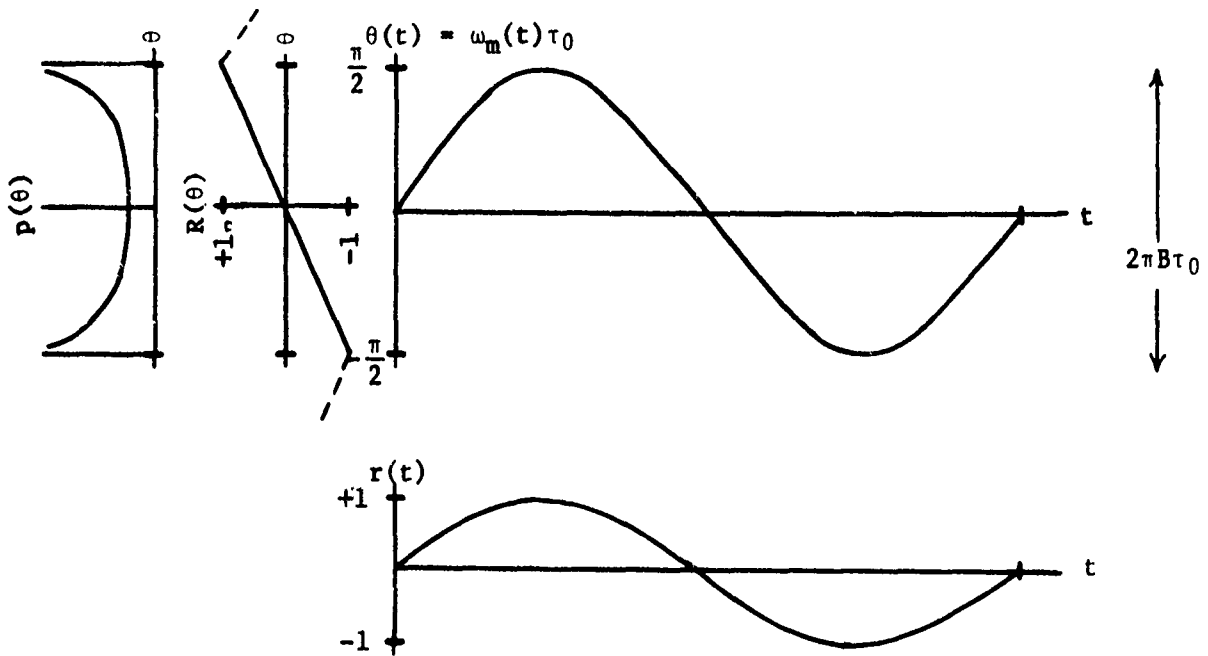

Figure 11: J_1 Ranging System

Step 1: $R(\theta)$ is linear, and with axes labeled as in Figure 11.

$$R(\theta) = \frac{2}{\pi} \theta$$

Step 2: It is convenient to let the range of the angle modulation by $\pm \pi/2$ (or $B\tau_0 = 1/2$) which implies half-wave symmetry. $R(\theta)$ is then a triangular wave which

has been defined over the interval $\pm \pi$ (beyond the limits of the modulation) to simplify the series representation. We then describe $R(\theta)$ in a harmonic series.

$$R(\theta) = \sum_{n=1}^{\infty} C_n \cos \left(n\theta - \frac{\pi}{2} \right)$$

where

$$C_n = \frac{8}{\pi^2 n^2} \sin \frac{n\pi}{2} \quad \text{and} \quad \phi_n = -\frac{\pi}{2} \quad .$$

Step 3: The range response is

$$RL = \sum_{n=0}^{\infty} C_n \left[\rho_0(\tau - n\tau_0) \cos \left(\omega_0 \tau + \frac{\pi}{2} \right) + \rho_0(\tau + n\tau_0) \cos \left(\omega_0 \tau - \frac{\pi}{2} \right) \right] .$$

For a sinusoidally modulated carrier $\rho_0(\tau)$ is given by

$$\rho_0(\tau) = J_0(\pi B\tau) \quad ,$$

and since $B\tau_0 = 1/2$,

$$\begin{aligned} RL &= \sum_{n=0}^{\infty} C_n \left\{ J_0 \left[\pi \left(B\tau - \frac{n}{2} \right) \right] \cos \left(\omega_0 \tau + \frac{\pi}{2} \right) \right. \\ &\quad \left. + J_0 \left[\pi \left(B\tau + \frac{n}{2} \right) \right] \cos \left(\omega_0 \tau - \frac{\pi}{2} \right) \right\} \\ &= -\sin \omega_0 \tau \left\{ C_n \left[J_0 \left[\pi \left(B\tau - \frac{n}{2} \right) \right] - J_0 \left[\pi \left(B\tau + \frac{n}{2} \right) \right] \right] \right\} . \end{aligned}$$

It is interesting to see the range response in terms of displaced J_0 responses. To be confident that these results are correct we may check to see if J_1 is indeed expressed in terms of the J_0 series. Taking a few as three terms, and checking point-by-point, we find that, to a good approximation,

$$\begin{aligned} 2J_1(\pi B\tau) &\approx \frac{8}{\pi^2} \left\{ J_0 \left[\pi \left(B\tau - \frac{1}{2} \right) \right] - J_0 \left[\pi \left(B\tau + \frac{1}{2} \right) \right] \right. \\ &\quad \left. - \frac{1}{9} J_0 \left[\pi \left(B\tau - \frac{3}{2} \right) \right] + \frac{1}{9} J_0 \left[\pi \left(B\tau + \frac{3}{2} \right) \right] \right. \\ &\quad \left. + \frac{1}{25} J_0 \left[\pi \left(B\tau - \frac{5}{2} \right) \right] - \frac{1}{25} J_0 \left[\pi \left(B\tau + \frac{5}{2} \right) \right] \right\} . \end{aligned}$$

The series is approximately equal to $2J_1(\pi B\tau)$ for $B\tau < 10$. Presumably, if the series is not truncated, the sum is identical to $2J_1(\pi B\tau)$. It is seen that many (perhaps useful) series expansions, such as this one relating J_0 and J_1 , may be generated using such analyses.

It was demonstrated earlier that any series expansion which describes $R(\theta)$ in the modulation interval will give the same range response. This may be verified for this example by defining $B\tau_0 = 1$ which then describes $R(\theta)$ as a sawtooth wave whereas defining $B\tau_0 = 1/2$ described $R(\theta)$ as a triangular wave. The series for a sawtooth converges less rapidly than the triangle series and consequently, more terms must be summed to obtain the range response.

A much simpler description is found by considering $R(\theta)$ to be a small portion of a large sinusoid with amplitude A as given by

$$R(\theta) = A \sin \theta .$$

Assuming $\sin \theta \approx \theta$, A is found by setting $R(\theta) = 1$ when $\theta = \pi B\tau_0$. $R(\theta)$ then becomes

$$R(\theta) = \frac{\sin \theta}{\pi B\tau_0} = \frac{\cos(\theta - \pi/2)}{\pi B\tau_0} .$$

Substituting $C_1 = \frac{1}{\pi B\tau_0}$ and $\phi_1 = -\pi/2$ gives the range response as

$$RL = \frac{\sin \omega_0 \tau}{\pi B\tau_0} [\rho_0(\tau + \tau_0) - \rho_0(\tau - \tau_0)] .$$

The choice of τ_0 can be made arbitrarily small (consistent with estimating $\sin \theta \approx \theta$) and $\rho_0(\tau - \tau_0) - \rho_0(\tau + \tau_0)$ can be written as a differential as

$$\lim_{\tau_0 \rightarrow 0} [\rho_0(\tau + \tau_0) - \rho_0(\tau - \tau_0)] = 2\tau_0 \rho_0'(\tau) .$$

The range response is then given by

$$RL = 2 \sin \omega_0 \tau \frac{\rho_0'(\tau)}{\pi B} .$$

This result holds for all IF correlators which use the modulation as the IF reference.

For this particular case $\rho_0(\tau) = J_0(\pi B\tau)$. Differentiating with respect to τ gives

$$\rho_0'(\tau) = \frac{d}{d\tau} [J_0(\pi B\tau)] = -\pi B J_1(\pi B\tau) .$$

The range response is then equal to the result known to be

$$RL = -2J_1(\pi B\tau) \sin \omega_0 \tau .$$

For this particular case, the equivalence of different expressions for the range response could be shown to be identical; however, in many cases, this equivalence may not be easily demonstrated.

Example 8: Hybrid Modulation Systems

The systems described in this example are designed to fulfill three objectives:

- (1) Provide a range response with good definition by controlling the envelope of the transmitted power spectrum;
- (2) Use quasi-replica correlation techniques to obtain displaced responses without using a delay line to produce the reference;
- (3) Synthesize a system which may be period-modulated (FM/FM) to produce a wideband IF in order to reduce the frequency ambiguities inherent in harmonic systems.

Figure 12 illustrates two different hybrid modulation/demodulation techniques which produce the same power spectra and range responses. Both techniques are

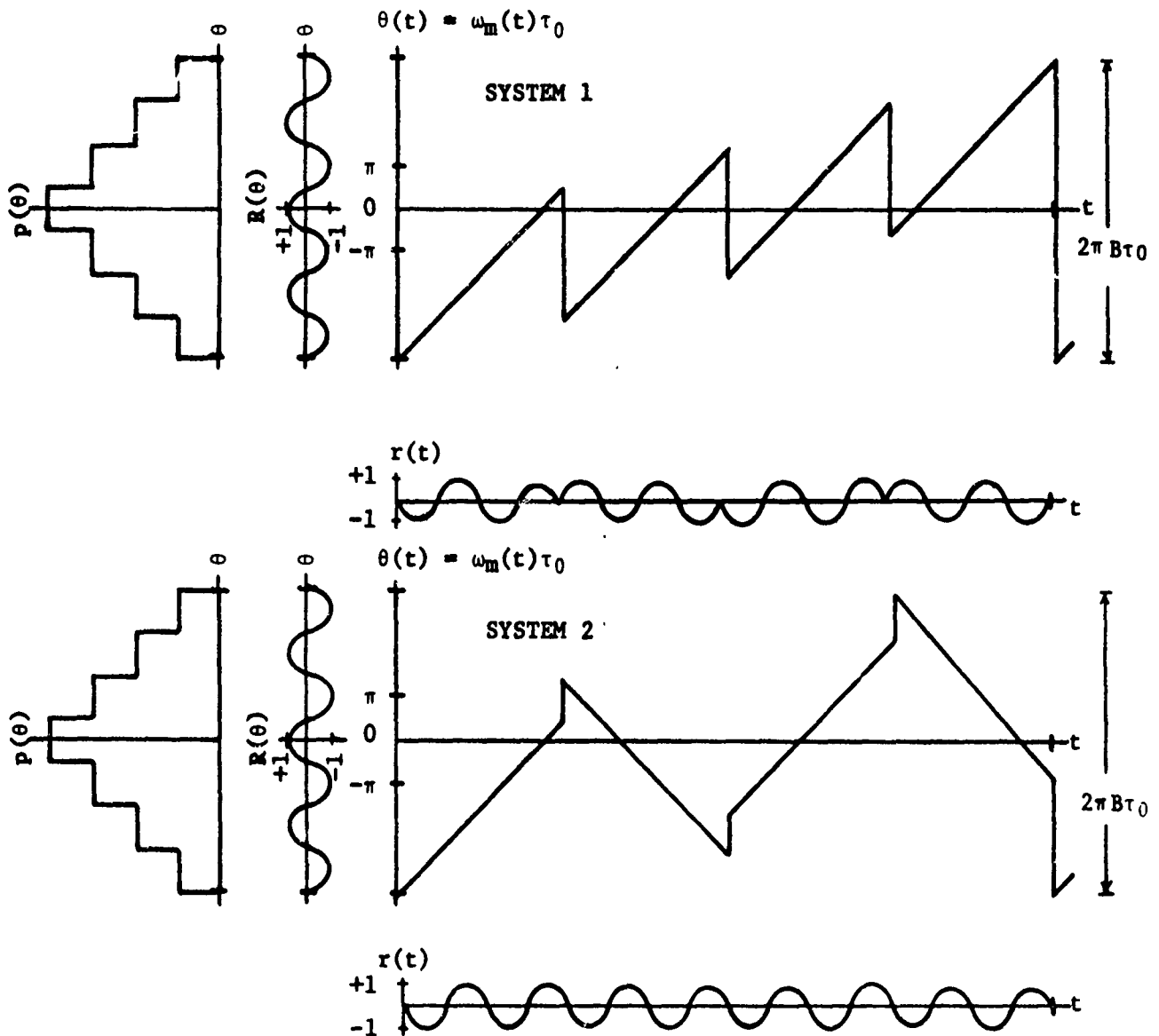

Figure 12: Hybrid Modulation Systems

implemented using sawtooth or triangle waveform generators which drive binary divider chains to produce a hybrid modulation consisting of the sum of analog and digital variables.

Steps 1 and 2: As seen in the figures, when $B\tau_0 = 7/2$ the reference is written as

$$R(\theta) = \cos \theta .$$

Step 3: Thus the range response becomes

$$RL = [\rho_0(\tau - \tau_0) + \rho_0(\tau + \tau_0)] \cos \omega_0 \tau .$$

Observing that the envelope of the power spectrum is the superpositioning of component rectangles, so that the Fourier transform of the power spectrum is the sum of the envelopes of the Fourier transforms of each component rectangle, we may write

$$\rho_0(\tau) = \frac{7}{16} \frac{\sin(\pi B\tau)}{(\pi B\tau)} + \frac{5}{7} \frac{\sin(\frac{5\pi B\tau}{7})}{(\frac{5\pi B\tau}{7})} + \frac{3}{7} \frac{\sin(\frac{3\pi B\tau}{7})}{(\frac{3\pi B\tau}{7})} + \frac{1}{7} \frac{\sin(\frac{\pi B\tau}{7})}{(\frac{\pi B\tau}{7})} .$$

Substituting $B\tau_0 = 7/2$ gives

$$RL = \frac{1}{16} \cos \omega_0 \tau \left[\frac{7 \sin \pi (B\tau - \frac{7}{2})}{\pi (B\tau - \frac{7}{2})} + \frac{5 \sin \frac{5\pi}{7} (B\tau - \frac{7}{2})}{\frac{5\pi}{7} (B\tau - \frac{7}{2})} + \frac{3 \sin \frac{3\pi}{7} (B\tau - \frac{7}{2})}{\frac{3\pi}{7} (B\tau - \frac{7}{2})} + \frac{1 \sin \frac{\pi}{7} (B\tau - \frac{7}{2})}{\frac{\pi}{7} (B\tau - \frac{7}{2})} \right. \\ \left. + \frac{7 \sin \pi (B\tau + \frac{7}{2})}{\pi (B\tau + \frac{7}{2})} + \frac{5 \sin \frac{5\pi}{7} (B\tau + \frac{7}{2})}{\frac{5\pi}{7} (B\tau + \frac{7}{2})} + \frac{3 \sin \frac{3\pi}{7} (B\tau + \frac{7}{2})}{\frac{3\pi}{7} (B\tau + \frac{7}{2})} + \frac{1 \sin \frac{\pi}{7} (B\tau + \frac{7}{2})}{\frac{\pi}{7} (B\tau + \frac{7}{2})} \right] .$$

Of course, the use of a squarewave reference would result in harmonic range responses according to the harmonics of the squarewave as in Example 5.

Example 9: Nulling of Sidelobe Responses in Hybrid Systems

Example 5 illustrates the problem of sidelobes in the range response of squarewave demodulated systems with uniform modulation probability density. These sidelobe responses are due to (1) the natural sidelobes of a $\sin x/x$ shaped response (caused by the uniform power spectrum), (2) the additional harmonic responses due to squarewave references $R(\theta)$, and (3) the overlap of the positively and negatively displaced response shapes which is significant when $nB\tau_0$ is small. Figure 13 illustrates a simple system for which the modulation is the sum of square and triangular waves and the reference is the squarewave. These waveforms can be generated using economical integrated circuit function generators which can be frequency modulated to obtain FM/FM type systems. The ratio of square to triangular wave in the modulation may be adjusted to place a null in the most undesirable sidelobe as described in reference [6].

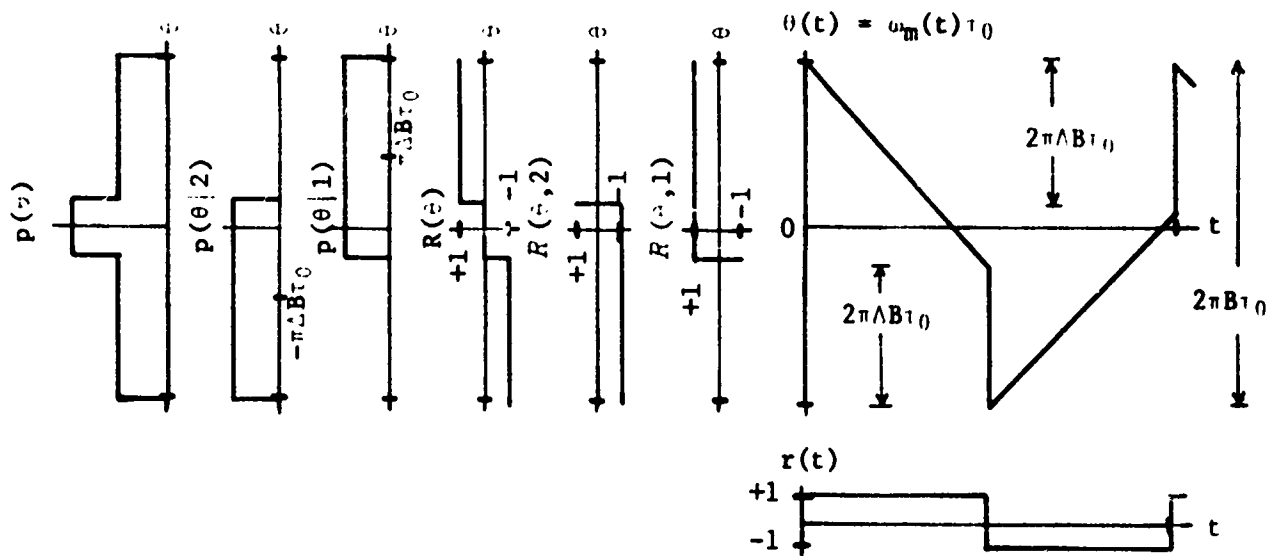

Figure 13: Hybrid System With Null at $\tau = 1/B$

In the figure we have shown p_1 and p_2 , corresponding to the component spectra, along with the respective component references, $R(\theta,1)$ and $R(\theta,2)$. The analysis may be completed in two ways:

(1) The composite reference $R(\theta)$ and the composite spectrum corresponding to $p(\theta)$ may be used to obtain an expression for RL terms of ρ_0 , $\{C_n\}$, and $\{\phi_n\}$.

(2) The range response may be regarded as the superpositioning of the responses RL_1 due to $R(\theta,1)$ and $p(\theta|1)$, and RL_2 due to $R(\theta,2)$ and $p(\theta|2)$. Results will not be of the same form as in (1), but, rather, in terms of $\sin x/x$ responses with doppler carrier frequencies of $\omega_0 + \pi\Delta B$ and $\omega_0 - \pi\Delta B$. These component responses are written

$$RL_1 = \rho_0(\tau) \cos(\omega_0 + \pi\Delta B)\tau$$

$$RL_2 = \rho_0(\tau) \cos(\omega_0 - \pi\Delta B)\tau$$

and

$$f_0(\tau) = \frac{\sin \pi(B-\Delta B)\tau}{\pi(B-\Delta B)\tau}$$

Thus the total response is written

$$\begin{aligned} RL &= RL_1 + RL_2 \\ &= \rho_0(\tau) [\cos(\omega_0 + \pi\Delta B)\tau - \cos(\omega_0 - \pi\Delta B)\tau] \\ &= \rho_0(\tau) 2 \sin \omega_0 \tau [\sin \pi\Delta B \tau] \end{aligned}$$

The term in brackets produces nulls at a $\tau = m/\Delta B$ ($m = 0, \pm 1, \pm 2, \dots$); therefore, we adjust ΔB so that the null for $m = 1$ occurs at the point τ_{null} of the most undesirable sidelobe peak:

$$\Delta B = \frac{1}{\tau_{\text{null}}}$$

This form of RL shows clearly the nulling term.

This example illustrates that expressing the range response in terms of $\rho_0(\tau)$ by determining the composite $R(\theta)$ is not necessarily simpler than summing the range responses from the individual components. In this particular case, the expression for ρ_0 may be of a form which provides little insight; certainly $R(\theta)$ is much harder to express than $R(\theta, 1)$ and $R(\theta, 2)$.

6. HYBRID MODULATION SYSTEMS AND TEST RESULTS

The following systems illustrate synthesis of desirable responses using the analysis techniques of this report (figures 14-30). Note that most of these hybrid systems are constructed so that they are easily period-modulated to achieve FM/FM systems.

Included in each test example will be a block diagram to show the implementation, the graphical analysis diagram showing modulation and demodulation time waveforms, as well as a functional description of the reference and the power spectrum. The resulting range responses obtained by measurement and by computation are also shown. Measurements were made employing a variable-length transmission line which introduces an approximate $1/\tau$ attenuation factor in the results. The line loss characteristic is shown in Figure 30.

The first system is a very simple system which may be used for wideband IF systems. The response consists of superpositioned $\sin x/x$ responses at amplitudes and displacements given by Equation (5.2) using square-wave parameters. The second system uses the same simple block diagram as System 1, but the components of modulation are added in different amounts, changing both the functional relationship $R(\theta)$ and the power spectrum. The effect is to introduce a null at approximately $B\tau = 5/2$, the peak of the highest sidelobe of System 1. System 2 is an implementation of the system described in Example 9. Systems 3 and 4 correspond to the two hybrid systems of Example 8. System 4 can be easily period modulated by frequency modulating the function generator. System 3 could have been implemented differently in order to allow period modulation. The 3rd harmonic response of Systems 3 and 4 can be nulled by the technique used for System 2.

The range response depends upon the power spectrum and the functional relationship of the modulation and demodulation; thus, two principles are involved in the synthesis of systems such as those of this section:

(1) The envelope of the power spectrum has the shape of the probability density of the modulation $p(\theta)$. This density is determined directly by the probability density of the modulating voltage $p(v_m)$ if the modulation characteristic is linear. We may design the spectrum (and thus ρ_0) by designing the modulation. Note that there are many modulations which will yield a desired $p(\theta)$. (See Example 8.)

(2) The functional relation $R(\theta)$ may be determined as in Section 4, given the modulation and demodulation time functions. However, in synthesis, we wish to specify the relation $R(\theta)$ to produce a certain response. The relation of R to $\theta = D\tau_0 v_m$ may be made inherent in hardware which operates on v_m to give $r(t) = g[v_m(t)]$. Alternately, we may map from the desired $R(\theta)$ through $\theta(t)$ to yield an $r(t)$ which is always correct, but which may not be conveniently generated. If $r(t)$ is not conveniently generated, alternative modulations $\theta(t)$ with the desired p.d.f. can be used to attempt simplification of $r(t)$.

It is clear from previous examples that there exists freedom in the choice of $\theta(t)$ and $r(t)$ to yield a desired $p(\theta)$ and $R(\theta)$. In the systems described here, a well-defined, displaced range peak is desired. We therefore choose a modulation $\theta(t)$ to approximate a desired spectrum shape corresponding to $p(\theta)$ and a reference $r(t)$ which maps approximately into a quasi-replica for $R(\theta)$. Since $p(\theta)$ and $R(\theta)$ do not uniquely specify $\theta(t)$ and $r(t)$, the designer must use insight and a knowledge of the limitations and economics of available hardware to determine an intelligent design.

7. CONCLUSIONS

A statistical analysis technique for IF correlator systems has been developed under the assumptions of slowly varying, high-index frequency modulation and small propagation delay. The technique involves a transformation of variables which allows expression of the reference as a function of the modulation. It is shown that the range response may be expressed in terms of the functional relationship of demodulation to modulation and the envelope of transmitted spectrum, which (under the high-index FM assumption) is proportional to the first-order probability density of the modulation. Because the analysis is based solely upon modulation statistics and the functional relation $R(\theta)$, randomly modulated FM/FM type systems may be easily analyzed (providing the functional relation and modulation statistics may be determined), whereas time analysis of such systems is often impractical. The approach is valid for all classes of IF correlators including harmonic systems and replica correlators and unifies the treatment of IF systems. Systems which may appear to be quite different in the time domain may indeed be shown to be equivalent using statistical/functional analysis. The technique yields the range response in terms of a sum of weighted quasi-autocorrelation functions which have been translated along the τ axis. These are determined solely by the probability density of the modulation. The displacements and weightings depend on the coefficients of a harmonic-series expansion of the function $R(\theta)$. The statistical description is particularly useful for analysis and synthesis of hybrid modulation/demodulation systems which are designed to have well-defined range responses and which may be period-modulated.

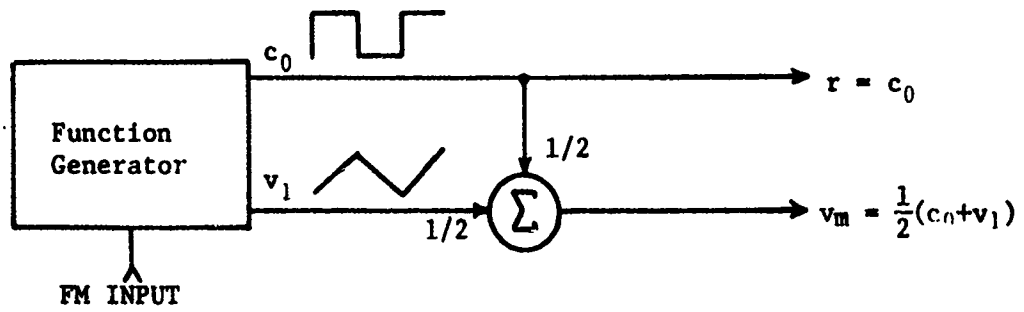

Figure 14: System 1 Block Diagram

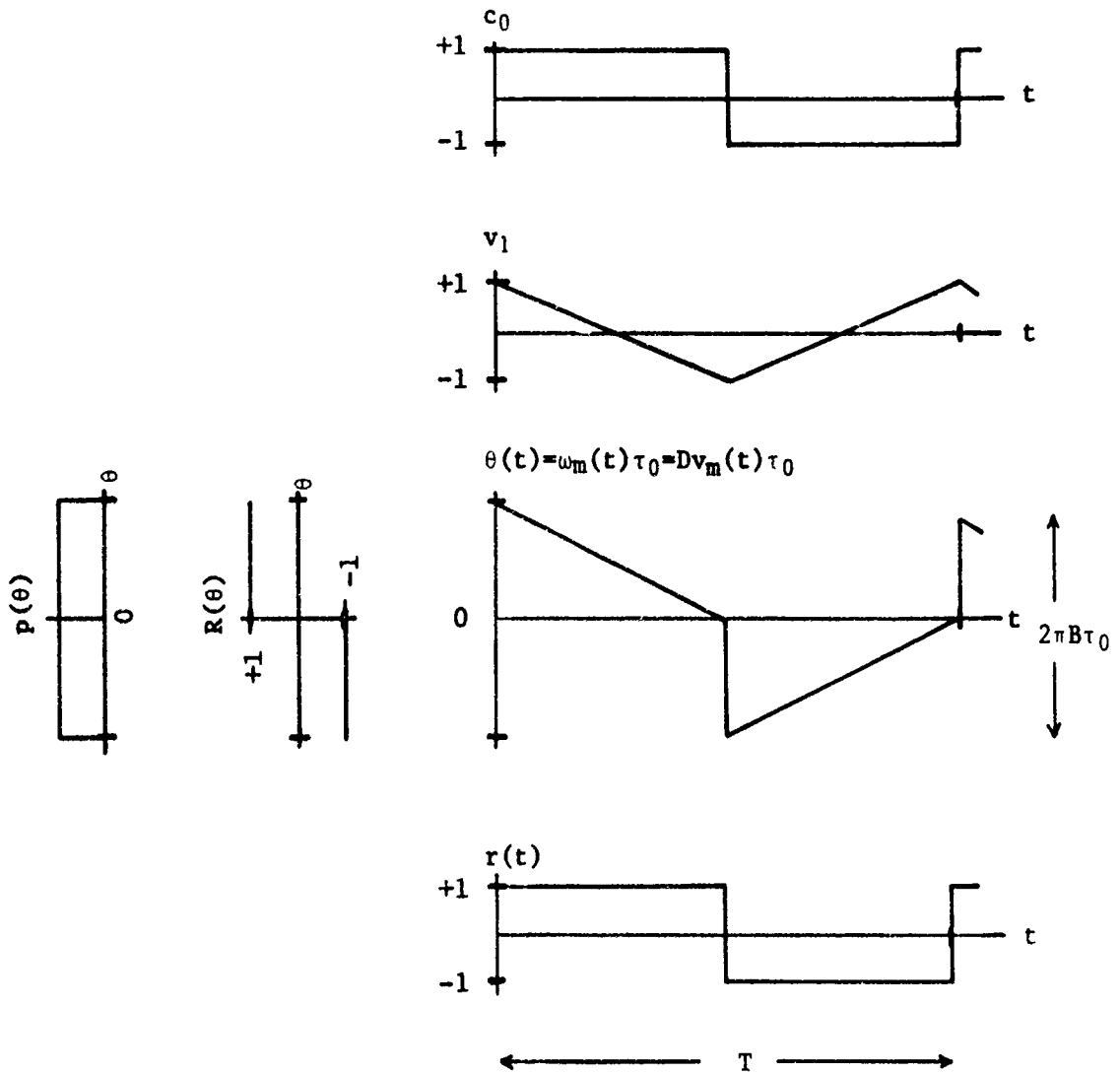

Figure 15: System 1 Graphical Mapping Diagram

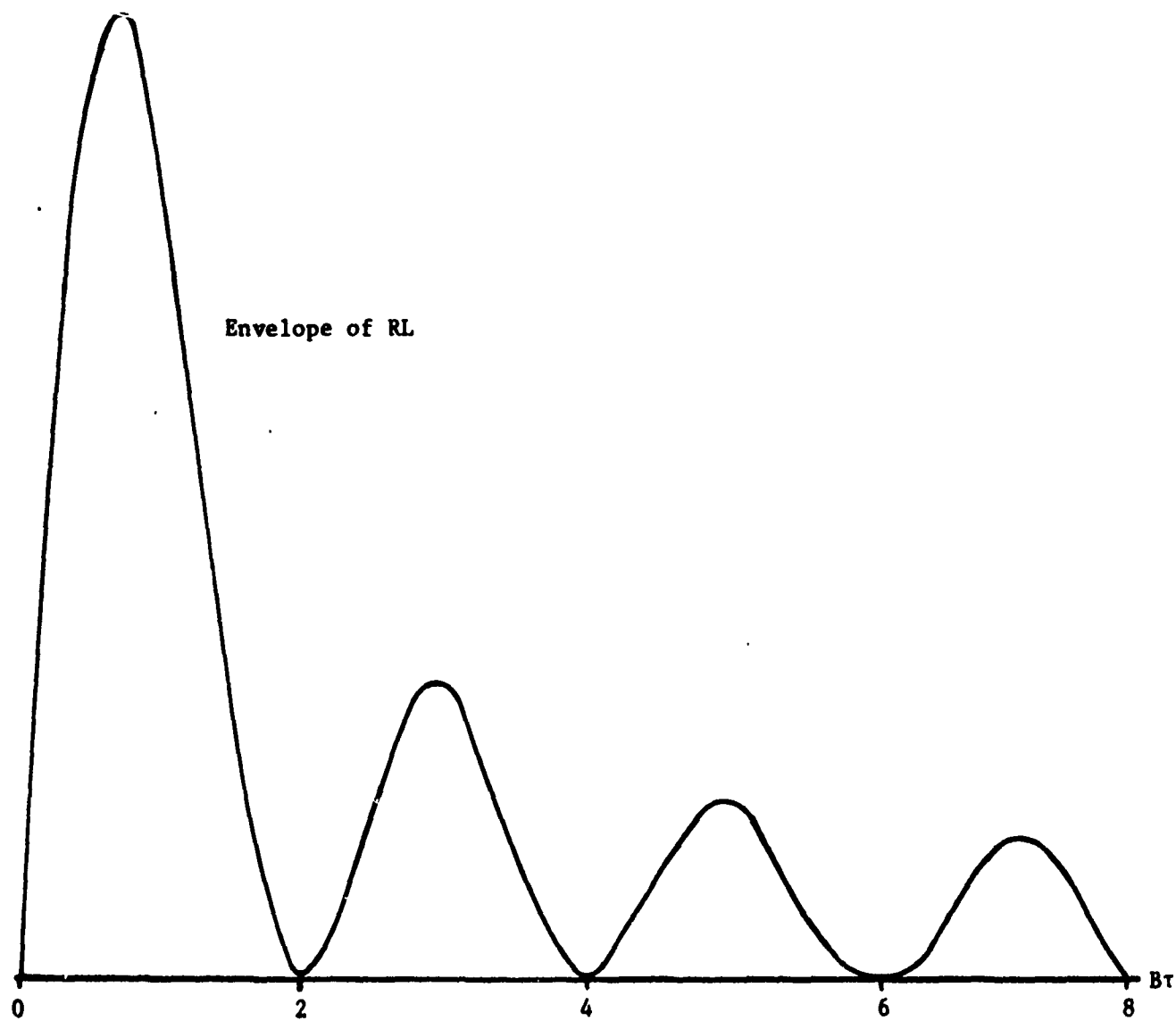

Figure 16: System 1 Computed Range Response

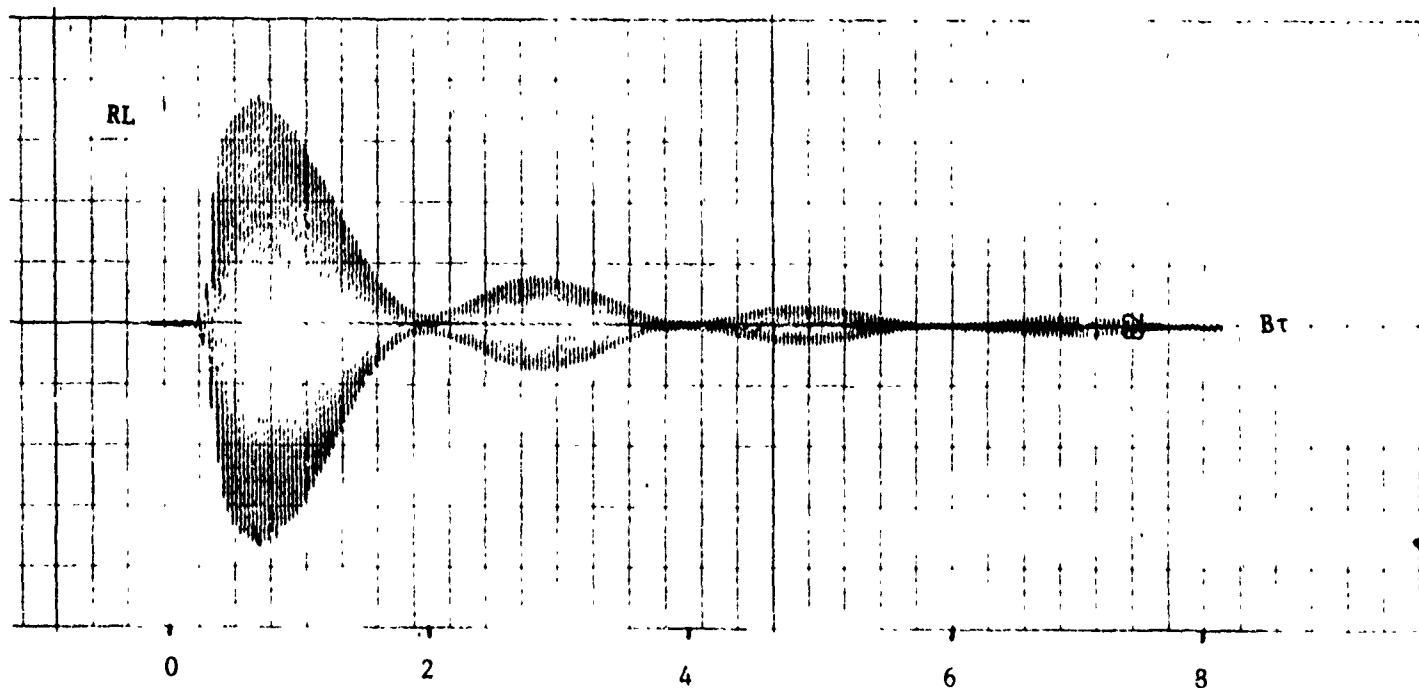

Figure 17: System 1 Measured Range Response

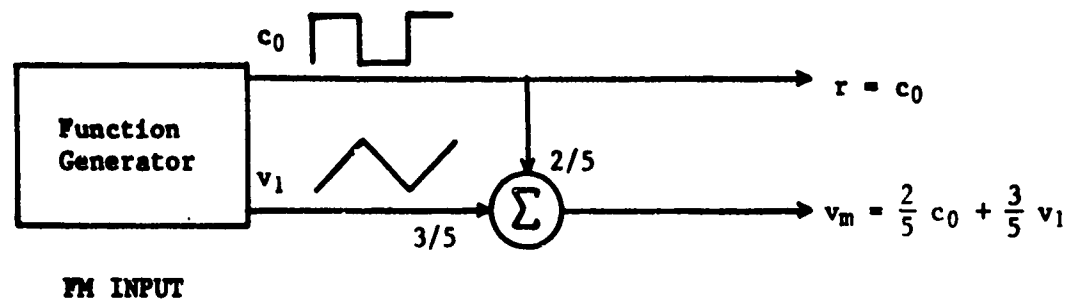

Figure 18: System 2 Block Diagram

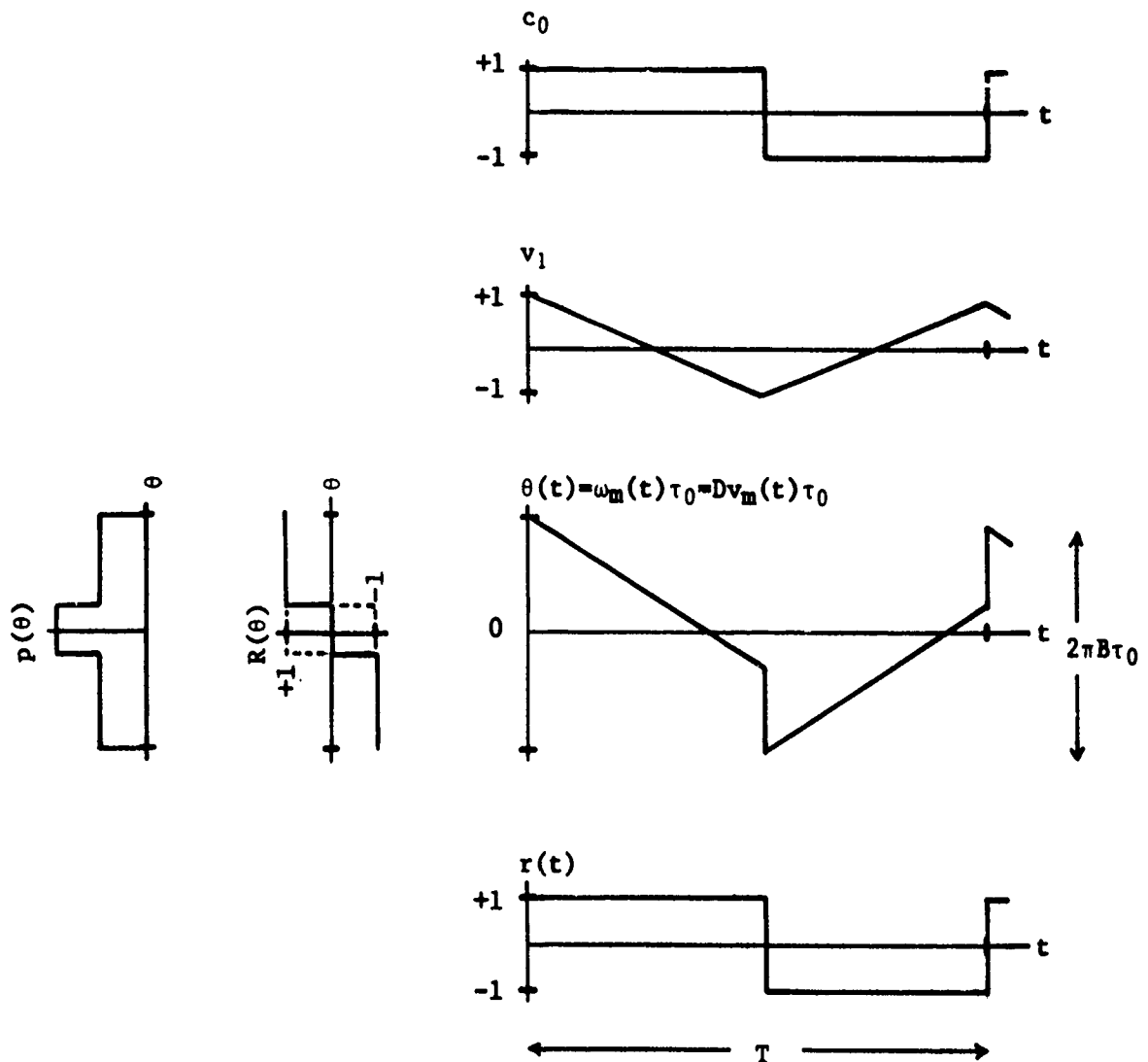

Figure 19: System 2 Graphical Mapping Diagram

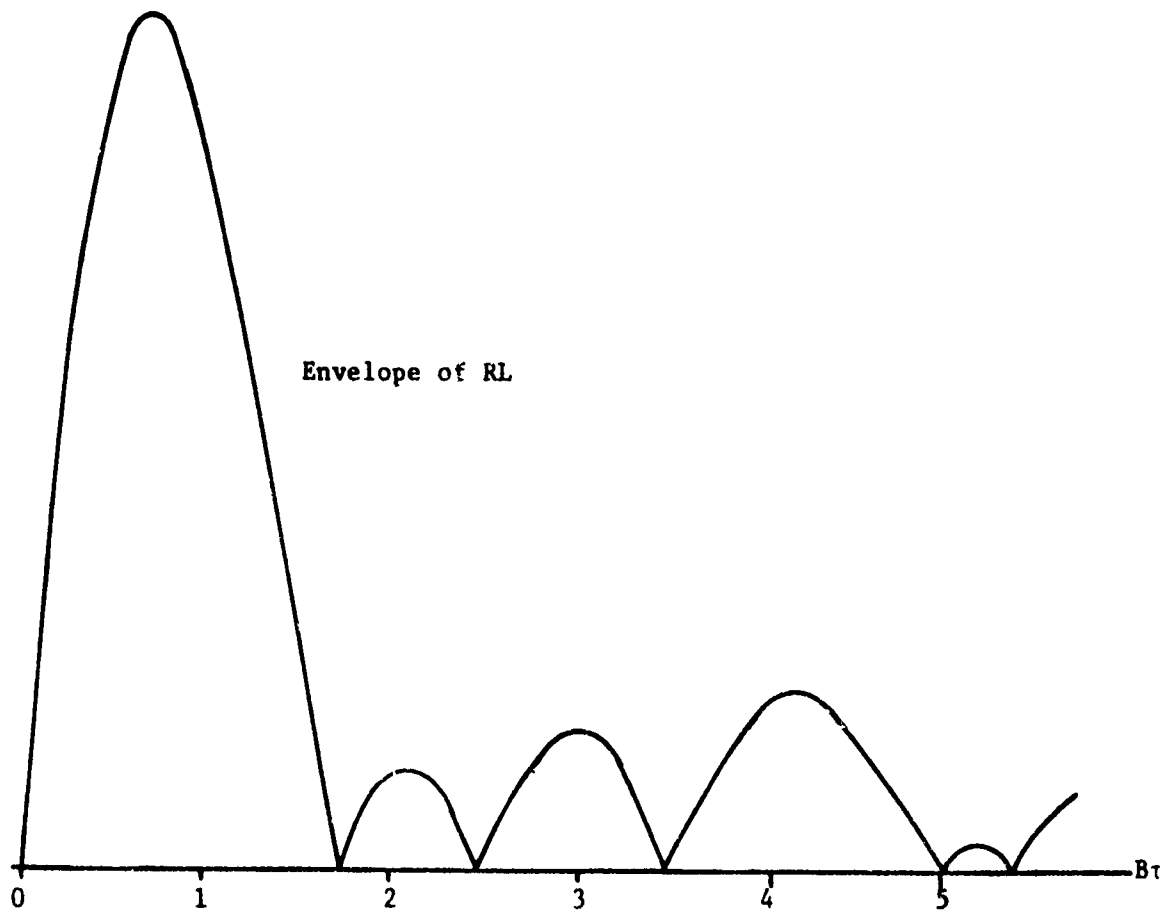

Figure 20: System 2 Computed Range Response

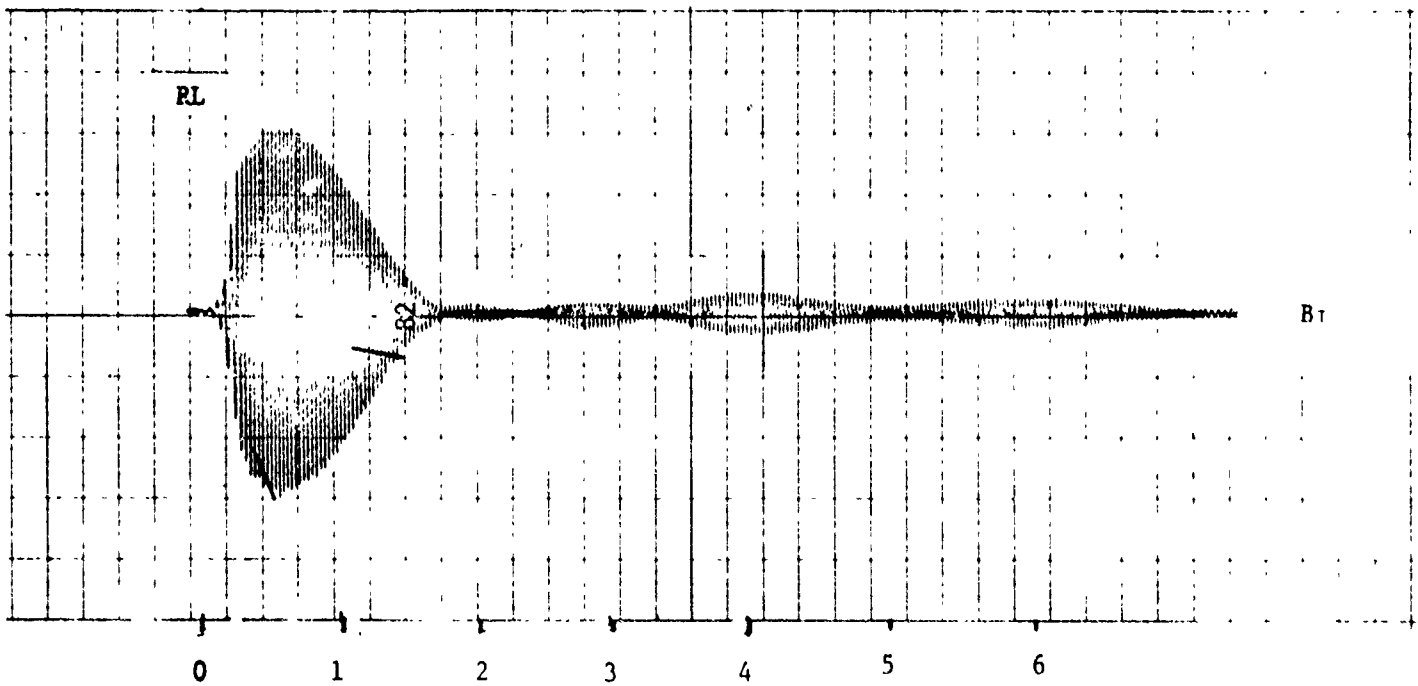

Figure 21: System 2 Measured Range Response

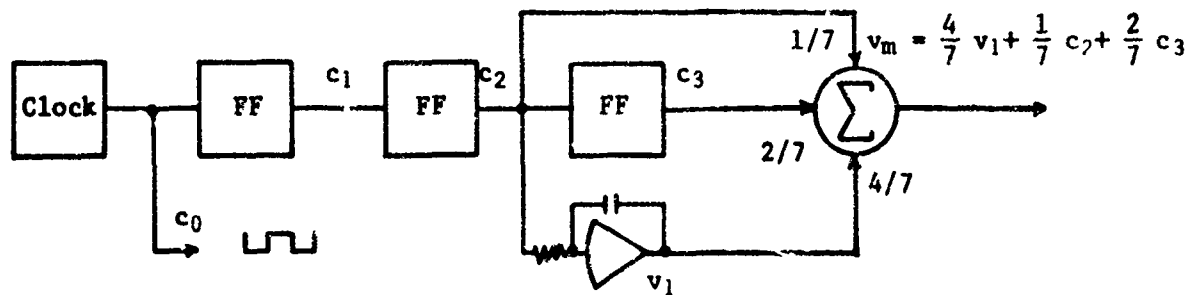

Figure 22: System 3 Block Diagram

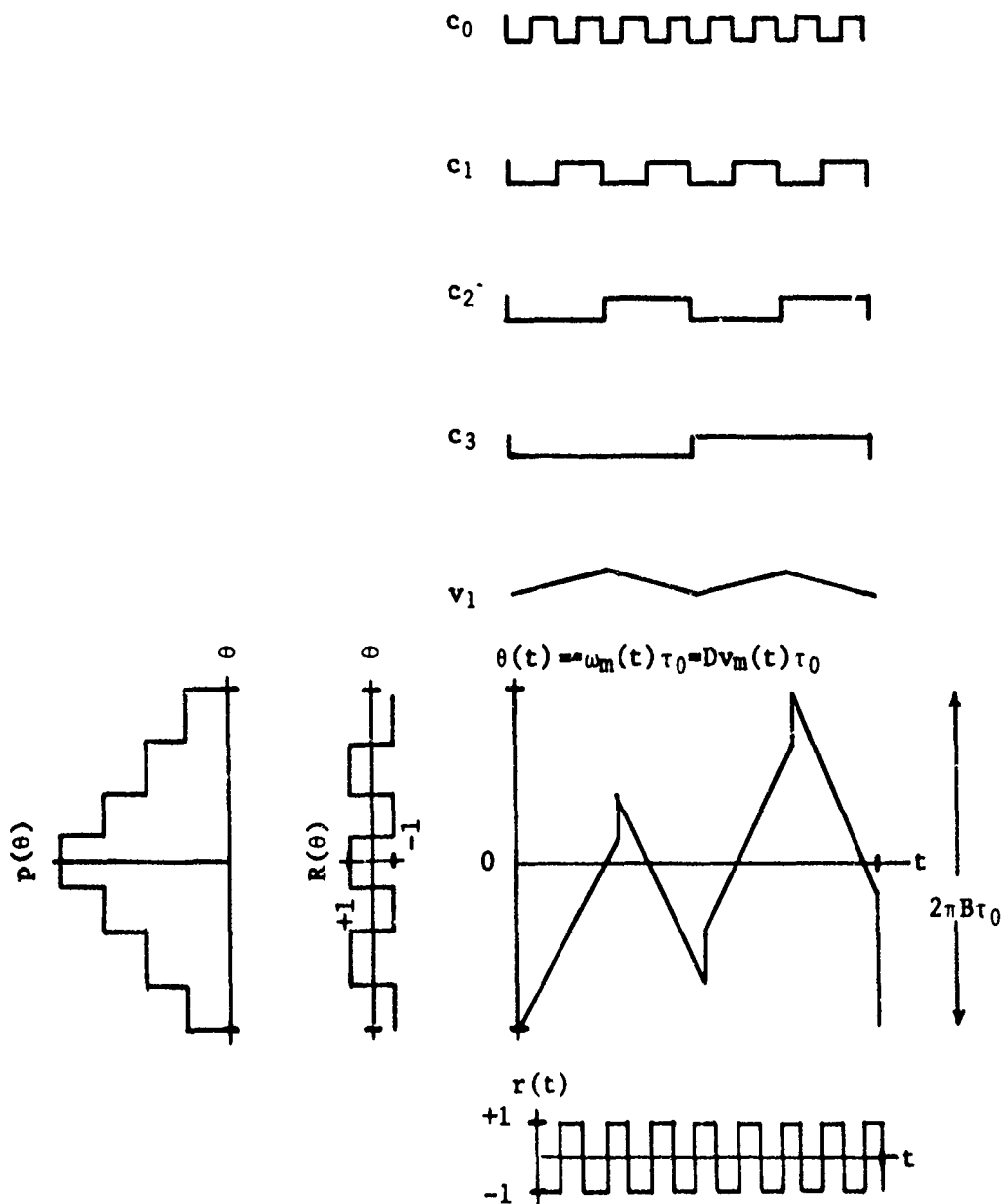

Figure 23: System 3 Graphical Mapping Diagram

Envelope of RL

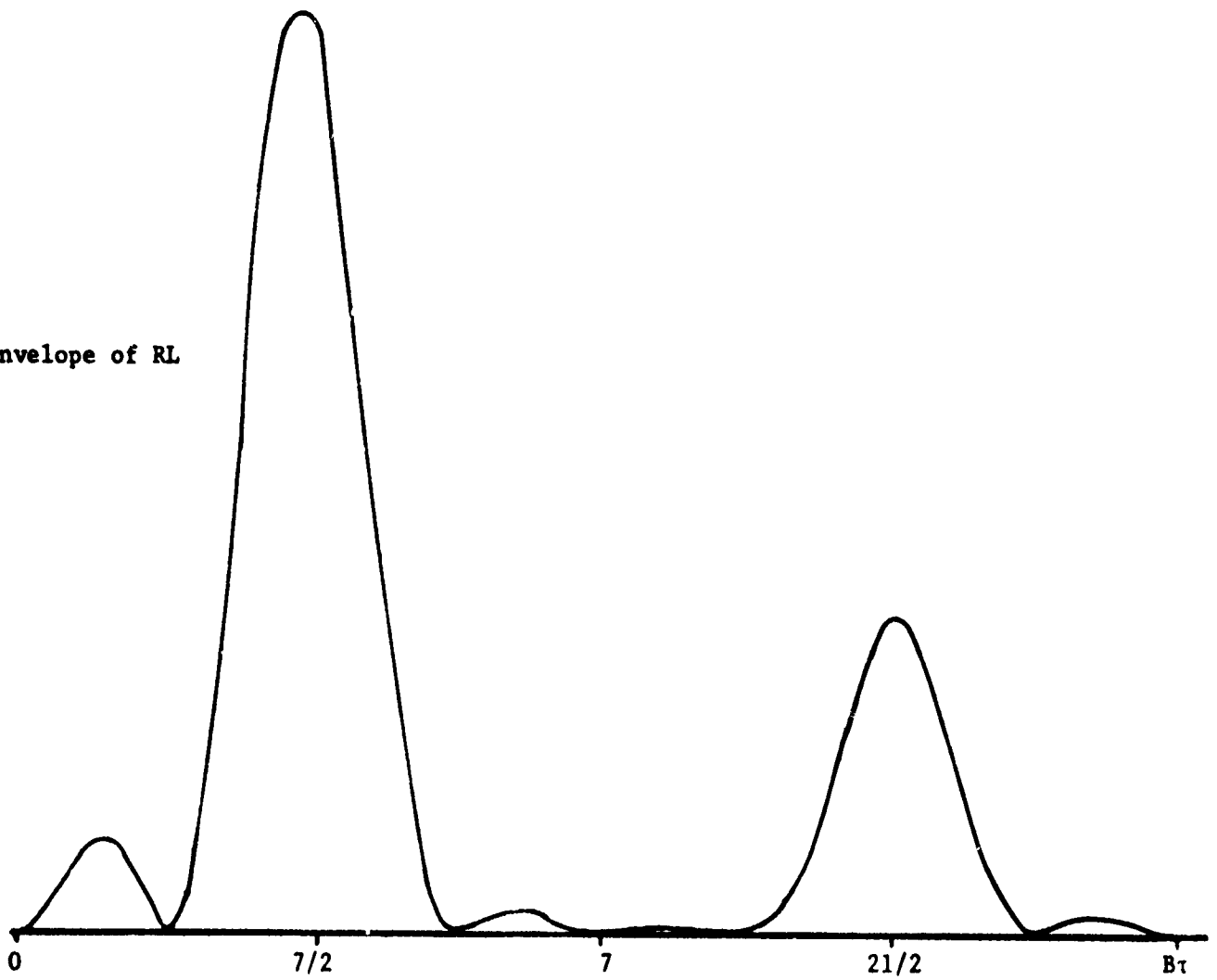

Figure 24: System 3 Computed Range Response

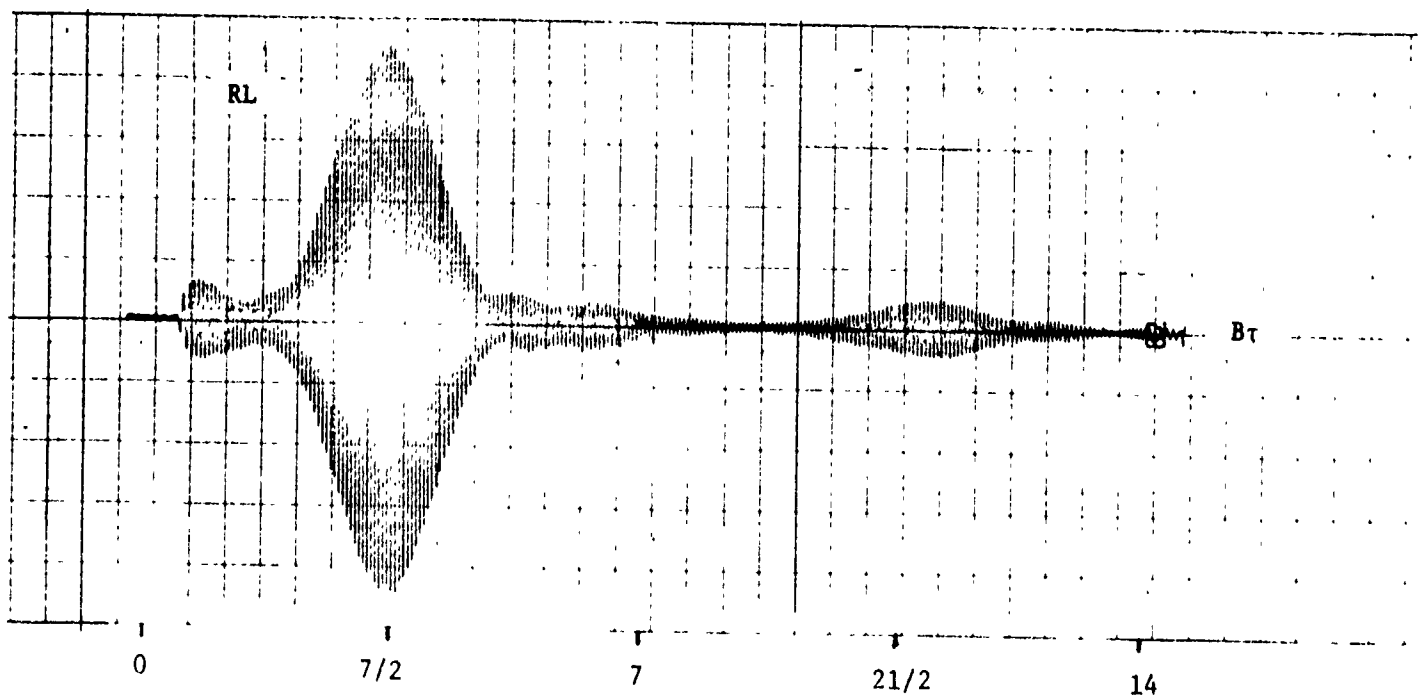

Figure 25: System 3 Measured Range Response

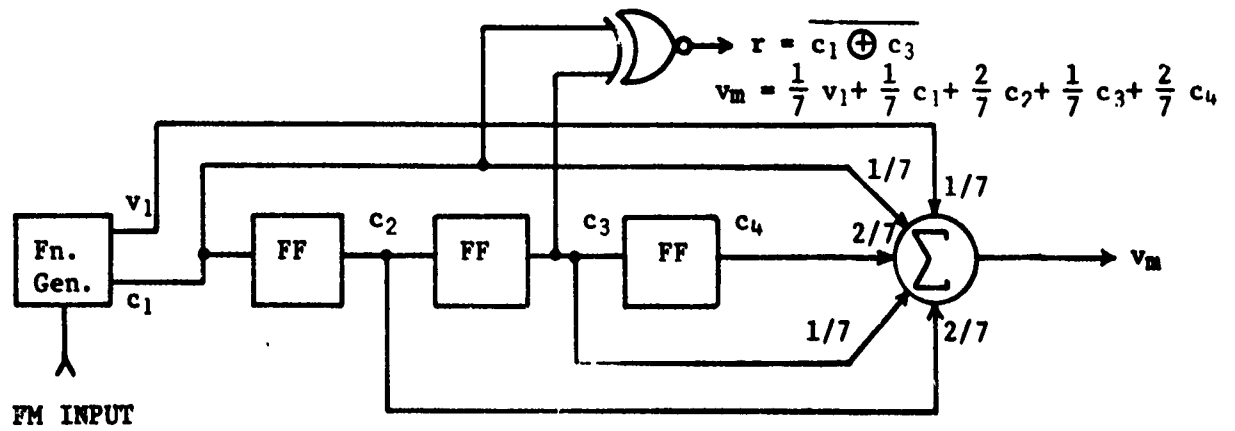

Figure 26: System 4 Block Diagram

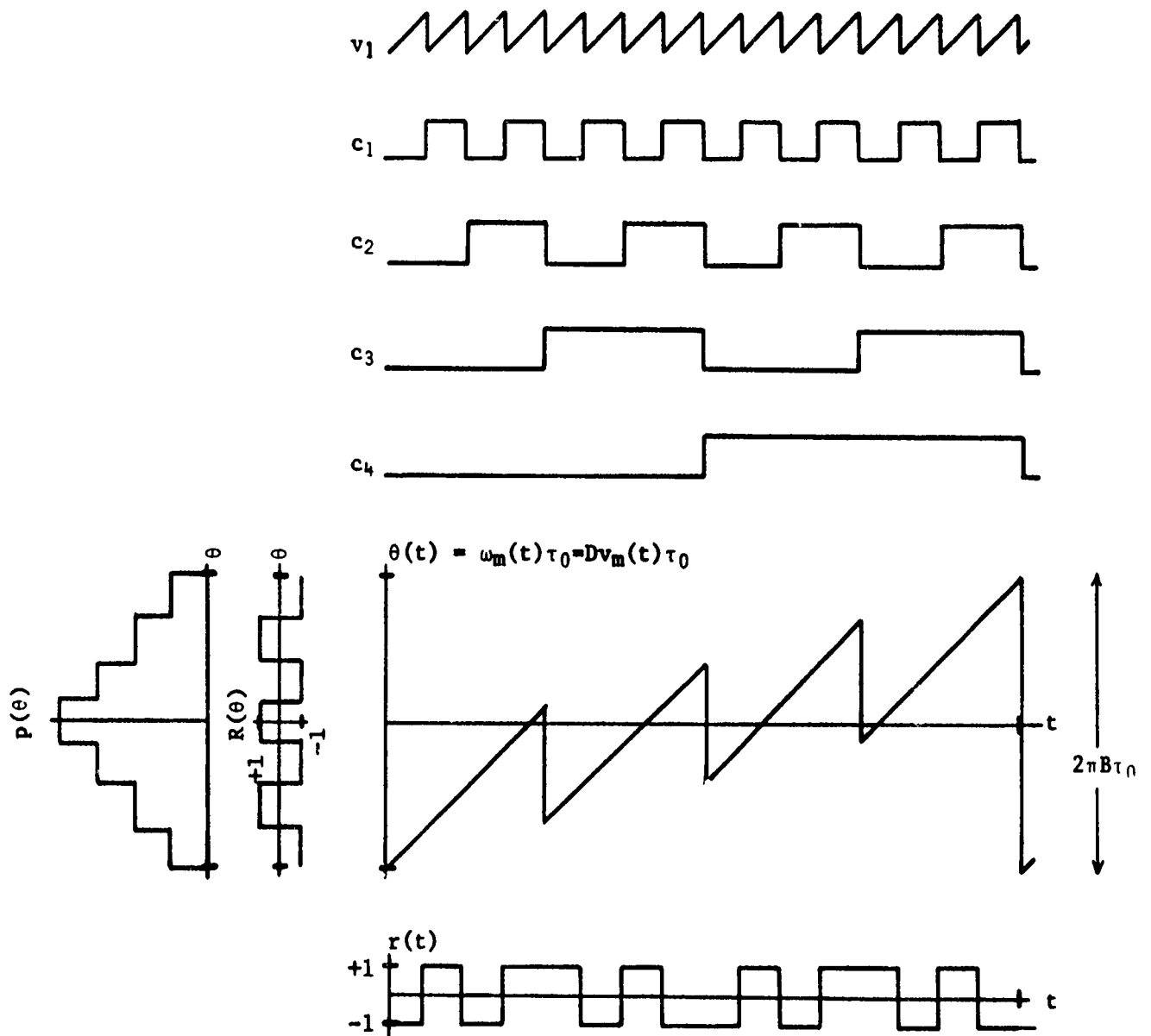

Figure 27: System 4 Graphical Mapping Diagram

Envelope of RL

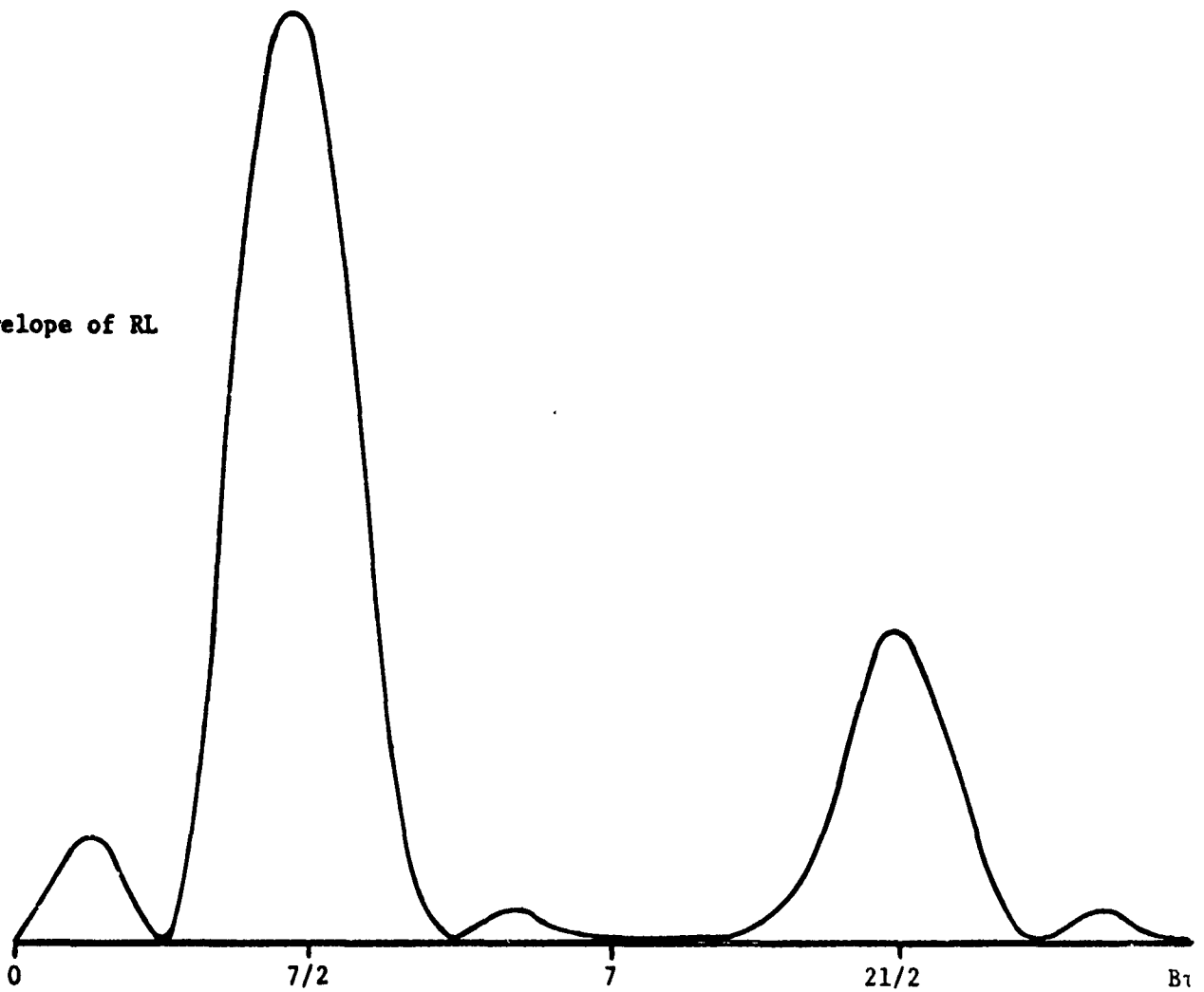

Figure 28: System 4 Computed Range Response

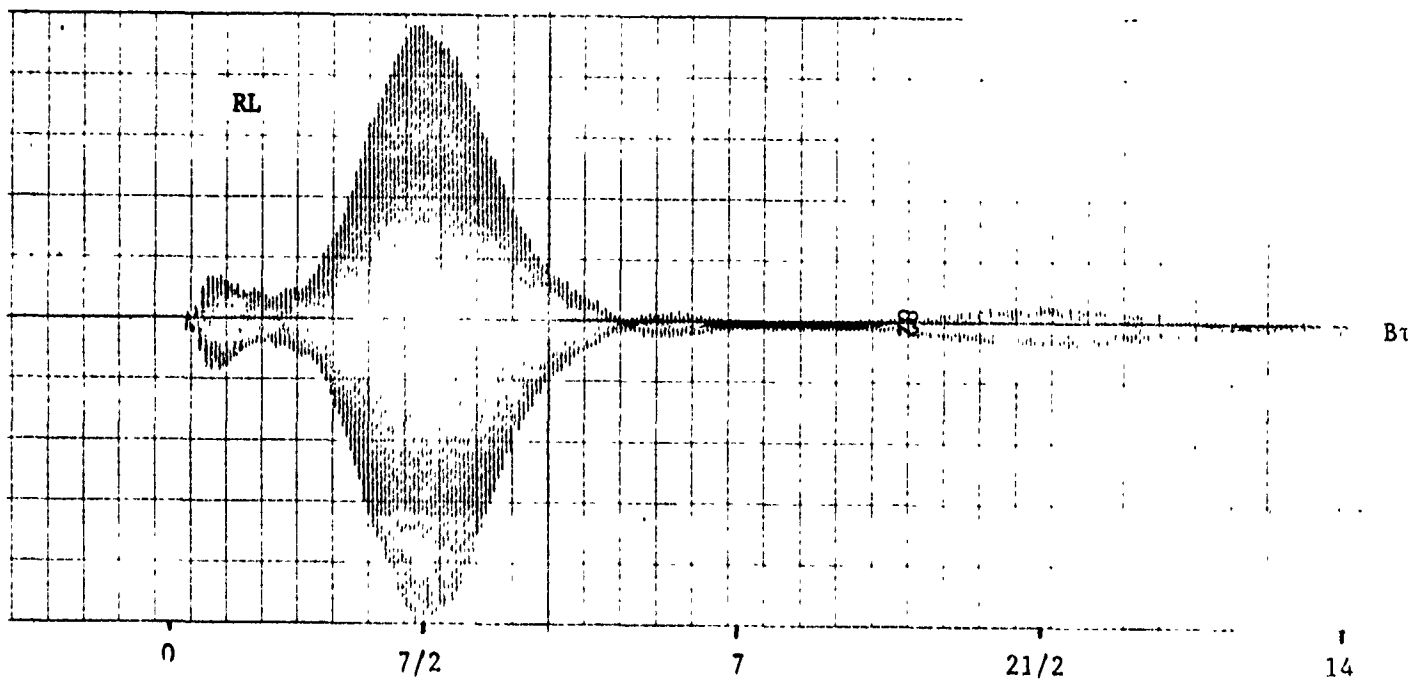

Figure 29: System 4 Measured Range Response

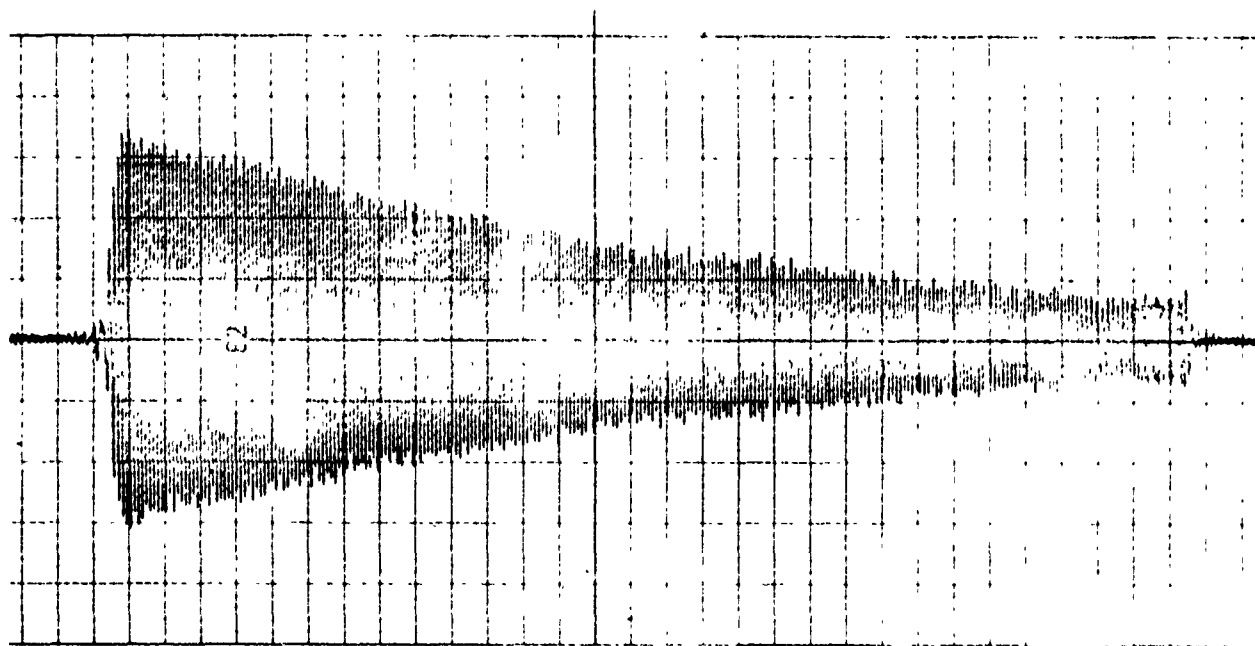

Figure 30: CW Range Response Showing Transmission Line Attenuation

REFERENCES

1. Peperone, S.J., "The Siam Fuze," HDL Report No. TR-1435, March 1969.
2. Tozzi, L.M., "Resolution in Frequency-Modulated Radars," Ph.D. Dissertation, University of Maryland, 1972.
3. Bartlett, M.C., "Harmonic Triangular FM Doppler Fuzing Systems for Low Height Applications," University of Florida Report No. 0164-1, February 1973.
4. Cross, J.L., "Effect of Amplitude Modulation on FM Ranging Systems," University of Florida Report No. 0058-5, November 1971.
5. Couch, L.W., "Effects of Modulation Nonlinearity on the Range Response of FM Radars," IEEE Transactions on Aerospace and Electronic Systems, vol. AES-9, July 1973.
6. Couch, L.W. and Johnson, R.C., "Range Laws for FM Radars with Harmonic Processing and Arbitrary Modulating Waveshapes," University of Florida Report No. 0169-1, November 1973.
7. Tozzi, L.M., "An FM Fuze System Using Synchronous Detection," HDL Report No. TR-415, December 1956.
8. Panter, P.F., Modulation, Noise and Spectral Analysis, McGraw-Hill, 1965.
9. Tozzi, L.M., "Linear Frequency Modulation of Oscillators," HDL Report No. TR-1586, March 1972.