

AD/A-002 489

ARPA POLICY-FORMULATION INTERROGATION
NETWORK

Jacques Vallee, et al

Institute for the Future

Prepared for:

Advanced Research Projects Agency

31 December 1974

DISTRIBUTED BY:

NTIS

National Technical Information Service
U. S. DEPARTMENT OF COMMERCE

**Best
Available
Copy**

(Security classification of title, body of abstract and indexing annotation must be entered when the overall report is classified)

1. ORIGINATING ACTIVITY (Corporate author) Institute for the Future 2740 Sand Hill Road Menlo Park, CA 94025		2a. REPORT SECURITY CLASSIFICATION Unclassified	
REPORT TITLE ARPA POLICY-FORMULATION INTERROGATION NETWORK		2b. GROUP	
3. DESCRIPTIVE NOTES (Type of report and inclusive dates) Final Report (6 March 1972 - 31 December 1974)			
4. AUTHOR(S) (First name, middle initial, last name) Jacques Vallee, Project Leader			
5. REPORT DATE 31 December 1974	7a. TOTAL NO. OF PAGES 117	7b. NO. OF REFS	
6a. CONTRACT OR GRANT NO. Contract No. DAHC 15 72 C 0165	8a. ORIGINATOR'S REPORT NUMBER(S) SR-34		
6b. PROJECT NO. Program Code No. A74880	8b. OTHER REPORT NO(S) (Any other numbers that may be assigned this report)		
6c. ARPA Order No. 2005	6d.		
9. DISTRIBUTION STATEMENT Distribution of this document is unlimited.			
11. SUPPLEMENTARY NOTES		12. SPONSORING MILITARY ACTIVITY Advanced Research Projects Agency Architect Bldg., 1400 Wilson Blvd. Arlington, VA 22209	
13. ABSTRACT <p>This report describes the findings of a project to develop a network conferencing capability. Six versions of a program named FORUM have been written and tested in a variety of applications. In addition, limited experience with the development of a voice capability is reported.</p> <p>The documents appended to this report provide greater detail on the architecture and operation of the network conferencing program (FORUM-5) and of the file structure supporting a more advanced prototype (FORUM-6).</p>			

DD FORM 1373
1 NOV 66

REPLACES DD FORM 1373, 1 JAN 54, WHICH IS OBSOLETE FOR ARMY USE.

UNCLASSIFIED

Final Report

31 December 1974

ARPA POLICY-FORMULATION INTERROGATION NETWORK

Contract No. DAHC 15 72 C 0165

Sponsored By:

Advanced Research Projects Agency

Principal Investigator: Jacques Vallee
(415) 854-6322

Contractor: Institute for the Future
2740 Sand Hill Road
Menlo Park, CA 94025

Effective Date of Contract: 6 March 1972

Contract Expiration Date: 31 December 1974

Amount of Contract: \$340,000

ARPA Order Number: 2005

Program Code Number: A 74880

The views and conclusions contained in this document are those of the authors and should not be interpreted as necessarily representing the official policies, either expressed or implied, of the Advanced Research Projects Agency of the U.S. Government.

CONTENTS

ILLUSTRATIONS	iv
SUMMARY	vi
I. INTRODUCTION TO COMPUTER CONFERENCING	1
II. THE FORUM SYSTEM	8
A. Background and Resources	8
B. Research Approach	14
C. The Network Environment	17
D. Voice Channel	20
III. EXPERIENCE WITH COMPUTER CONFERENCING	25
A. Conferencing and Data-Base Systems	25
B. FORUM in Research	29
C. Inhouse Applications	34
D. FORUM Conferences on the ARPA Network	45
IV. CONCLUSION	55
A. Major Findings	55
B. Future Directions	56
APPENDIX 1: FORUM USER GUIDE	59
A. Joining a FORUM Activity	60
B. User Functions	63
C. Special FORUM Services	64
D. Chairman Functions	72
E. Chairman Upper-Level Command Mode	81
APPENDIX 2: PROGRAM ORGANIZATION AND PERFORMANCE	84
A. General Structure	85
B. Program Modules	89
C. Data Structures	94
D. Analysis	104
REFERENCES	109
Bibliography	110
Papers from FORUM Project	111

ILLUSTRATIONS

Figure 1.	Parameters in Four Communication Media	6
Figure 2.	ARPA Network, Logical Map, January 1974	9
Figure 3.	Work Station Used in Computer Conferencing (Showing the Use of a Parallel Voice Channel	11
Figure 4.	FORUM Laboratory, Phase 1	13
Figure 5.	Communication Modes	18
Figure 6.	Communication Functions on ARPANET	19
Figure 7.	Remote Access to a Computer Conference	21
Figure 8.	Voice-Conferencing Hardware (Prototype 1)	24
Figure 9.	FORUM Experiment on ARPANET with Information Retrieval Coupling (7 June 1973)	26
Figure 10.	Growth Curve for Two Institute Conferences	35
Figure 11.	Categories of Entries in a FORUM Staff Conference	36
Figure 12.	Growth Curve for User Conferences	47
Figure 13.	Entering a FORUM Conference	61
Figure 14.	Information Elicitation in a FORUM Conference	67
Figure 15.	Display of Probability Estimates	69
Figure 16.	Setting Up a FORUM Conference	73
Figure 17.	Setting Up a Conference Agenda	75
Figure 18.	Setting Up Activities within an Agenda	77
Figure 19.	General Concepts in FORUM-6	86
Figure 20.	Simplified State Diagram	87
Figure 21.	Overall Organization of the FORUM-6 Program	91

Figure 22.	File Structure	95
Figure 23.	Participant's File	97
Figure 24.	Global Directory	98
Figure 25.	Private Message File	100
Figure 26.	Activity File	101
Figure 27.	Activity File (Text Entry Directory)	102
Figure 28.	Activity File (Activity Participants Directory)	103
Figure 29.	Storage Statistics for Two FORUM Conferences	106
Figure 30.	Retrieval Statistics for Conference #1	107
Figure 31.	Retrieval Statistics for Conference #2	108

SUMMARY

From March 1972 to December 1974, the Institute for the Future has developed and released six successive versions of a policy-formulation and conferencing system for use on the ARPA computer network. All programs were written in assembly language for a PDP-10 computer operating under TENEX. The two most advanced versions, known as FORUM-5 and FORUM-6, are described in detail in the present document. In addition, the design of voice channels to be used in connection with computer conferences is discussed.

The most significant findings from this effort are in the area of the development of file structures to support the complex interaction capabilities described in the report and in understanding the human factors of group interaction--as necessary for policy-formulation activity--through a machine.

I. INTRODUCTION TO COMPUTER CONFERENCING

Descriptions of advanced societies by science-fiction writers and technical experts alike have familiarized us with the concept of communication systems which are not bound by the constraints of time and space. A common feature of these systems is a method for instant idea exchange between people separated by large distances. Not only can one individual communicate with another, but groups can be brought into conferences by transporting the images or thoughts of the individual participants rather than their physical bodies.

Recent forecasts of industry trends agree with this concept and project important social effects. Electronic meetings would permit radical changes in work patterns and would alter the office environment significantly. In a 1971 study of broadband information services to the home, Paul Baran noted:

"...going to a place of work where physical goods are transformed is decreasing in importance, as the percentage of GNP generated by service industries increases; even today, more GNP is derived from service industries than from manufacturing. Furthermore, with an anticipated reduction in working hours and increase in traffic congestion, there will be a growing wish by many to work at or near home in lieu of going to the 'office'."*

Whether communication takes place from the home or a field office remote from the central work location, computer-assisted meetings may play as important a role in future planning and decision-making patterns as telephone conversations have until today. Murray Turoff, addressing the participants at the International Computer Communications Conference in 1972, pointed out:

"...the seemingly straightforward concept of automating the conference call on a modern time-shared computer system offers a

*Paul Baran, *Potential Market Demand for Two-Way Information Services to the Home, 1970-1980*, Report R-26, Institute for the Future (December 1971), p. 14.

unique ability to allow effective communication within larger groups than would normally be possible in a telephone conference call."*

Reviewing these concepts, J.C.R. Licklider defined the role the computer should play in such interaction. According to him, the computer:

"...could introduce a dimension not ordinarily available in face-to-face conferences. It could provide on-line information retrieval and processing for example, retrieval and reduction of data from on-line data bases, and dynamic display of models retrieved from files of models maintained within the network."**

Taking as an example the case of a scientist who participates in a series of meetings concerned with planetary science, Licklider commented upon the value of teleconferencing (which he defined as "interaction among geographically separated people as though they were together at a conference"); this scientist typically:

"...does not like to travel; he is interested in cutting down the number of meetings that he has to attend in Washington. Perhaps more fundamentally, he is concerned that the thinking and planning that goes on between meetings is less effective than it should be. Should it not be possible for subsets of the committee, groups of two or three scientists interested in a particular facet of the overall problem, to interact through telecommunication channels? Should it not be possible for them, in such interaction, to take advantage of computer-processable data bases, computer-program models, and packages of computer programs designed to facilitate the kinds of calculations involved in the planning of space exploration?"***

According to Turoff:

"Economics already favors computerized conferencing, even for fairly small groups, within organizations that have computers and terminals. As mini-system and terminal costs decline and digital

*Murray Turoff, "PARTY-LINE and DISCUSSION Computerized Conference Systems", in Stanley Winkler, ed., *Computer Communications: Impacts and Implications*, Proceedings of the First International Conference on Computer Communication, Washington, D.C. (October 1972), p. 161.

**Brown, Miller, and Keenon, eds., *Report of the Summer Study on Information Networks* (New York: John Wiley & Sons, 1973), p. 155.

***Ibid., p. 156.

data networks come into wide use, we should by the late seventies find this communication mode to be quite commonplace."*

The loss of time and the expense involved in traveling are not the only inefficiencies in face-to-face meetings. They can lead to decisions made under pressure, and there is rarely an accurate record of the conversations. Also, many potential contributors are excluded from these meetings by time and distance constraints. Decisions made in face-to-face situations often leave participants with the feeling that a greater degree of creativity and plain wisdom would have been possible in an environment which facilitated full communication and the sharing of documented facts.

Applications of computer conferencing are not limited to science. Decision-makers in all fields often report that they spend too large a part of their time traveling to meetings and conferences. The energy shortage of 1973/74 has dramatized this fact and has led many to reconsider the need for such extensive travel activities and to search for communication alternatives. In the February 1974 issue of *Telecommunications*, Paul Polishuk addressed the question of the possible savings in the substitution of telecommunications for transportation. It would enable, he wrote,

"...the employed population to work, plan, and socialize closer to the individual residences of the employees. Particularly appealing, other than as an energy conservation mechanism, is a better quality of life for the individual citizen. Bonus effects would accrue in that pollution would be lessened in the metropolitan geographic areas. traffic congestion on main arterials into and out of metropolitan areas would be decreased, and less time would be consumed in journeys to and from work."

In early December 1973, when the Netherlands was without gasoline, the newspapers reported that use of the telephone increased by ten to twenty percent. Confirmation of such an effect by accurate statistics would point to the existence of a serious opportunity for more widespread use of electronic communications. In the military field, the availability of transportable, geographically distributed management systems is an obvious requirement. Here again, teleconferencing could make a significant contribution to their design.

*Murray Turoff, "Human Communication via Data Networks", *Computer Decisions* (January 1973), p. 25.

Although our society claims to make good use of advanced technology, most decision-making is still taking place through mechanical action rather than through electronic-equipment support of intellectual effort. Very little technology has been made available until now to unburden the manager faced with cumbersome communication problems. Most businessmen travel every day by car, airplane, and train to go to work. Once in the office, they again resort to mechanical means to make their thoughts manifest: they fill out forms, write letters that have to be typed by physically hitting pieces of paper with miniature hammers, and they move physical blocks of files and reports through the organization to accomplish visible results.

The efficiency of this type of work decreases with distance between workers much more rapidly than an inverse square function. Contact with people in the next office involves a finite commitment and effort. Contact with personnel in another wing of the building complex is certainly not casual. And dealing with a part of the organization in another city calls for a range of cumbersome systems, such as the mail, the telephone, the telegraph, and transportation.

It is useful at this point to recall some statistical facts of business activity. Thorngren and Goddard* have found that 12 to 15 percent of all external business contacts involved more than two participants. Few of these multiperson contacts take place by electronic communication. This needs to be contrasted with the fact that over 80 percent of all two-person business contacts occur by telecommunications.

In order to improve the quality of decision-making, it is necessary to modify the nature of multiperson communication and, in particular, to change its dependence on space to such an extent that thoughts are equally clear, equally well documented, and equally accessible no matter what the locations of the author and recipient. Its dependence on time must be changed in such a way that the pressures of travel schedules and the synchronization of attendance (as in face-to-face and telephone conference calls) are no longer important factors in decision processes.

*Reported in Final Report, Volume 3, Communications Studies Group (September 1973).

In an effort to compare computer conferencing with other modes of communication, we have summarized the major parameters of interaction in four major contexts in Figure 1: face-to-face, computer network, voice, and voice plus video. The apparent advantages of computer conferencing are (1) the availability of an accurate record for both review and distribution, (2) a tie to processing services, (3) the possibility of immediate display of group views, and (4) the possibility of anonymity, which allows the expression of personal statements without group pressure. Its current drawbacks are (1) the lack of social contact among participants, (2) the requirement for typing, (3) the loss of visual information, and (4) the sensitivity of the system to technical failure.

As early as 1963, the Institute for Defense Analyses sponsored research into early forms of teleconferencing in the context of high-level crises. Reviewing teleconferencing applications in use in the United States at that time, Human Sciences Research, Inc., noted that most of the available experience was with telephone and teletypewriter conferences and with closed-circuit television; no computer conferencing was employed at that time, but teletype networks were no longer novelties. The authors of the report recalled that:

"...the government has experienced teletypewriter conferencing on several past occasions. In the 1948 Berlin crisis, a large volume of teletypewriter conferencing occurred."*

Use of the ordinary teletype in such interaction led to some problems, however:

"The one thing most emphasized by the State Department representative was the need for administrative control on a teletype net. This need for circuit discipline on teletype is particularly due to the characteristic of the equipment that if more than one station transmits at once the message will be mutilated."**

These remarks point to the need for an environment that supports the conferencing function in multistation discussion, provides a variety of flexible

*Gerald Bailey, Peter Nordlie, and Frank Sistrunk, *Review of Telecommunications Applications in Use in the United States*, Institute for Defense Analyses (20 September 1963), pp. 3-18.

**Ibid., pp. 3-18.

PARAMETERS OF COMMUNICATION	UNAIDED FACE-TO-FACE	NETWORK CONFERENCING	RECORDED CONFERENCE CALL	RECORDED VOICE + VIDEO
Maximum Number of Sites	One	Number of Ports to the Machine	Five	Two
Availability of Accurate Record	No	Yes	Possible	Possible
Link to EDP Services	No	Yes	No	No
Emotional Contents	High	Low	Fair	Fair
Signal Transmission Capability	Large	Fair	Small	Large
Typing Requirement	No	Yes	No	No
Visual Display Possible	Yes	No	No	Yes
Sensitive to Technical Failure	No	Yes	Small	Small
Can Preserve Anonymity	No	Yes	No	No
Allows Aggregation of Numerical Data	No	Yes	No	No
Cost (Commercial Rates)	12¢ per Min. \$100 per Day	\$15-60 per Hour per Participant	Phone Charges	\$230 per Hour*

*Based on the rate charged by the British Post Office for its Conferovision service. Conference Picturephone service between Chicago and New York is \$6.50 per minute; and service between Washington, DC and New York is \$2.50 per minute.

Figure 1. Parameters in Four Communication Media

activity structures, and decreases the reliance on simultaneous, interactive exchanges where all participants must physically be present at terminal stations at the same time.

Modern computer networks have the required properties for such an environment. Conceived by its developers as an experiment in resource sharing, the ARPA network, in fact, provides a communication capability as a by-product of its data processing power. The program described here draws from both of these capabilities.

II. THE FORUM SYSTEM

A. BACKGROUND AND RESOURCES

The Institute for the Future began its investigation of teleconferencing through its interest in the improvement of methods by which experts from diverse fields address problems in social forecasting and technology assessment. In March 1971, the Institute proposed to the Advanced Research Projects Agency:

"...to explore the applicability of on-line group conferencing for policy formulation via computer terminals. The key goal of such conferencing will be the effective use of judgmental data as input for forecasting, planning, and decision-making, where the participants are geographically separated."

In organizing this research, we were able to draw from the previous work of Olaf Helmer and Paul Baran, at the Institute for the Future, and from the efforts of Murray Turoff, at the Office of Emergency Preparedness; Thomas Sheridan, in citizen participation research at Massachusetts Institute of Technology; Norman Dalkey, with computerized Delphi at the Rand Corporation; and others. Our approach is unique, however, in at least four respects.

1. The system is designed to support flexible discussions that may be organized in real time, and deals with computer conferencing as a telecommunications medium.
2. The project encompasses the development of hardware for a computer-controlled voice channel supplementing the typed interaction.
3. The project environment permits observation of the conferences and the gathering of statistics for research purposes.
4. For the first time, an international computer network, ARPANET (see Figure 2), is used as the implementation environment.

To create an advanced form of teleconferencing, we have implemented and successfully tested a computer system called FORUM, which is now in routine operation on the computer network of the Advanced Research Projects Agency.

The basic idea of FORUM is to allow unhampered interaction of participants under the guidance of an organizer who defines a topic of discussion, assembles a panel of participants on that topic, and presents the material relevant to the subject. Each participant establishes communication with the computer network via a portable terminal with a standard typewriter keyboard. FORUM is able to convey questions and answers, assemble group opinions, protect anonymous statements, and supply other information to, and within, the group while the organizer monitors the proceedings and intervenes as necessary.

In order to illustrate the nature of the interaction made possible by FORUM, it is appropriate to imagine a hypothetical discussion* among a group of experts on the subject of the projected availability of mineral and energy resources in the period 1980-1990. The participants are about twenty in number. Among them are planners, economists, geologists, and petroleum experts. Two are specialists in computerized data bases. In addition, there might be representatives from power and utility companies and the president of a mining corporation. The organizer of the conference has experience in dealing with groups and is familiar with the various techniques which can be brought to bear on the elicitation of forecasts and intuitive judgments in areas of high technology.

This hypothetical conference differs from the usual workshop in that the participants are not meeting face-to-face. Instead, they are geographically separated and use a variety of communication media. Some are sitting around a terminal in a Washington, D.C., office building. A geologist is in the computer room of the Branch of Computations of the U.S. Geological Survey in Denver. One of the economists is in his office at Stanford University. Another one may be sitting in his study at home in New Jersey or in London, for that matter. (These experts are in telephone communication with a central operator who can instantly advise them of the status of the conference, of the progress of work done in subcommittees, or of the reasons for any particular difficulty or delay.) The substantive part of the interaction takes place through entries typed on standard terminals. All of the terminals are connected to the network and are controlled by a computer.

*Actual examples drawn from real-life conferences are given in Section III and in other parts of this report.

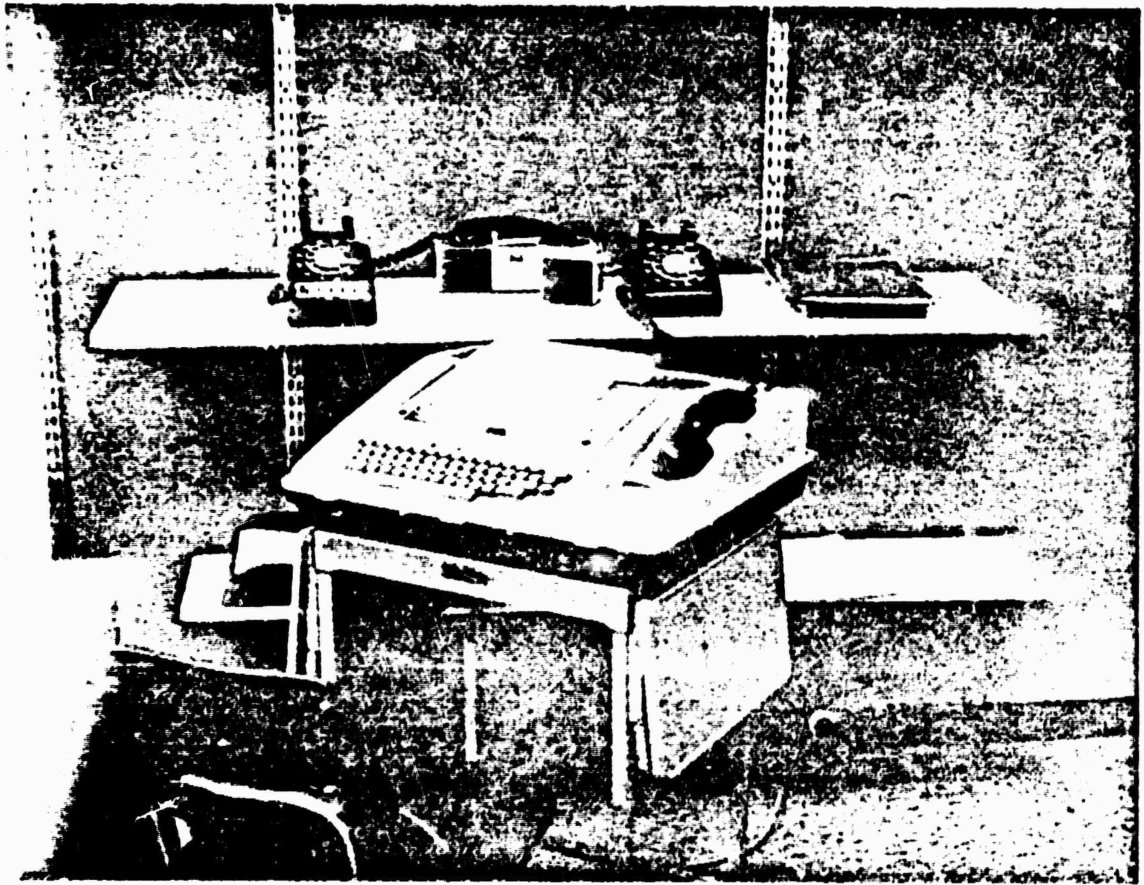

Figure 3. Work Station Used in Computer Conferencing
(Showing the Use of a Parallel Voice Channel)

This is the capability of FORUM.

Before describing our research approach, instrumentation, and findings in detail, it is useful to describe the environment in which the work has taken place. The Institute for the future is a small, nonprofit organization formed in 1968. It has special expertise in the development of short- to medium-term forecasting techniques. It receives support from private foundations, private corporations, and government agencies for the development of descriptions of future environments and for the improvement of techniques through which to arrive at such forecasts. In both types of assignments, the extraction of the collective thought of groups of experts is a critical task.

The Institute does not have its own computer. All of the work on ARPANET is performed via remote terminals, most of them of the portable variety illustrated in Figure 3. These terminals are linked to the network by ordinary telephone lines concentrated by a small, remote computer known as a TIP, or Terminal Interface Processor. Once the connection to the TIP has been obtained (by dialing a local telephone number), we proceed by requesting access to one of the network's "host" computers where the FORUM program is stored. At the same time, other ARPANET users may be entering the network at other node points, such as Washington, D.C.; London; or Oslo; through local phone calls. The specific computers we have used on the network are those of the Information Sciences Institute (ISI) at the University of Southern California in Los Angeles and the Bolt, Beranek and Newman Company (BBN) in Massachusetts. They are of the Digital Equipment Corporation PDP-10 type and use the TENEX time-sharing executive.

The facilities available at the Institute (see Figure 4) consist of two blocks of three rooms, separated by a distance of about 200 feet and constituting a miniature laboratory for office automation. In these offices, we have installed a variety of terminals. Over the first year of the project, mainly devoted to programming, four terminals were used. This number was expanded to eleven over the second year to permit experimentation with alternative work styles where staff members could, for example, have terminals in their homes. Terminals were occasionally loaned to outside parties involved in field tests conducted by our group. One terminal is a Terminet printer,

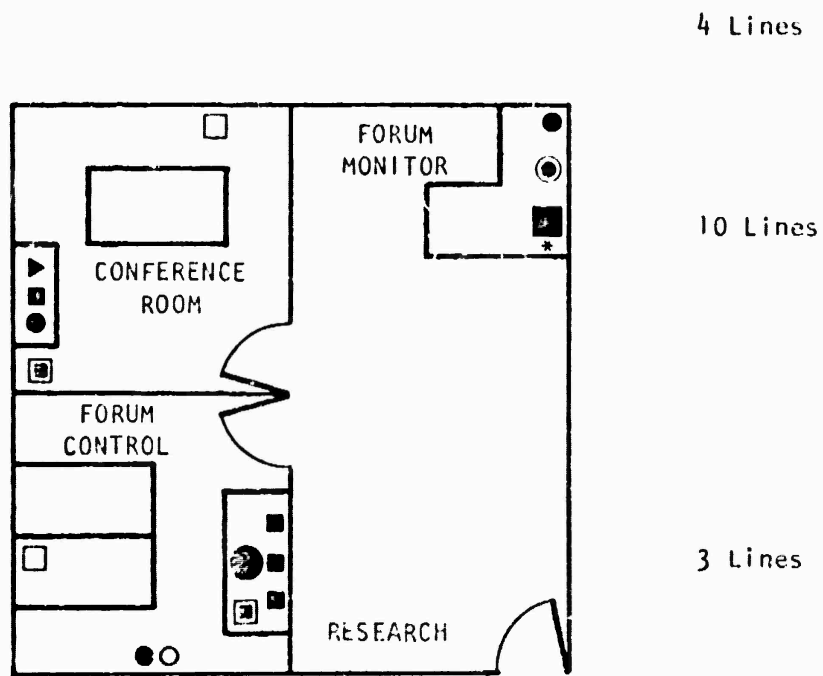

- ▶ Speakerphone
- Single Outside Phone Line
- Main Institute Phone Line
- Phone
- Control Box
- * Autodialer
- ▶ Hard-Copy Terminal
- Printer
- ⊙ Tape Cassette Terminal
- ⊙ Voice Channel Hardware
- ▣ Cathode Ray Tube Terminal

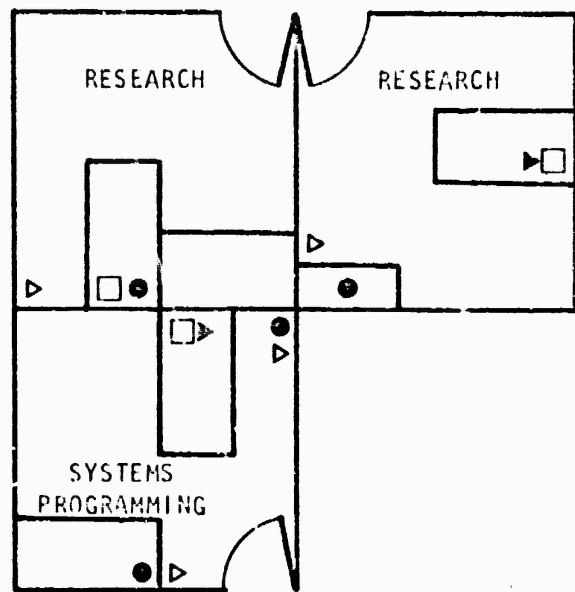

Figure 4. FORUM Laboratory, Phase 1

and another is a cathode ray tube display operating at a high transmission rate (1200 baud input). This rate is made possible by the hardware interface at the nearest access node, the NASA/Ames TIP entry point to the network. One work station is used by the conference controller and contains a terminal with tape cassettes that permits the storing of conference text in tape archive form.

B. RESEARCH APPROACH

The central problem of implementing a computer conferencing system clearly reduces to that of identifying, defining, and implementing a range of structures under which the participants are able to share information and enter comments into a common computer-storage file.

The implementation of a system like FORUM raises unusual problems of design: a group of experts or decision-makers typically does not have much knowledge of, or interest in, computer technology per se. There is no opportunity to train them in the use of a text-oriented language before the conference. And it is not feasible to ask them to interface with their peers through information specialists because each participant has a unique awareness of the problem at hand and needs to experience direct contact with his data and with other participants in order to perform at the "cutting edge" of his thinking.

When a group of conferees communicates via FORUM, each participant uses a terminal of the type that can be rented for \$150 a month or less. Once the terminal has been logged into the network, the user is presented with a list of discussions which he can attend (just as he would if he were to walk into the lobby of a convention center to review the day's program). Having selected an activity, the conferee is given a short background statement describing the activity. He is then free to observe the ongoing discussion, to review past comments entered into the conference, or to start typing his own remarks (see Figure 3). At any point during the discussion, a conferee can send a private message to another participant or make an anonymous entry. All of these communication modes (which Appendix 1 of this report attempts to characterize in a more formal manner) can be entered without the participant having to learn a single command, thus avoiding a major problem of most

interactive systems in existence; namely, that system commands get in the way of the person who types and clutter the transcript with extraneous lines that only have meaning for the machine.

An important facet of FORUM conferences lies in the ease with which the participants have access to services outside of the discussion itself: they can, for instance, submit a prepared statement to the rest of the group or insert parts of the discussion into a personal file. They can also draw responses from a data-base system and enter them into the general discussion. Clearly, the level of interaction thus reached is one not found in face-to-face meetings where experts are cut off from their files and personal notes.

The initial tasks in the FORUM project included an analysis of the available resources and a review of the existing terminal technology in terms of character set, plotting symbols, size of frame, speed of presentation, and interface standards. A decision involving the programming language to be used had to be made early; after exploration of the languages available on the PDP-10 under the TENEX operating system, we reluctantly concluded that assembly language was the only suitable medium to gain access to shared files and to control terminal behavior, both functions being critical to our goal. Additional requirements were speed and low central-processor utilization.

Actual development of the FORUM program proceeded through a series of stages identified as "releases". The version currently running on ARPANET is release 5. Most of the user experience reviewed in Chapter III of this report was based on this release. A description of the various release features is useful for the record.

Release 1 was the first package that formed a working system. It included the capability to simulate simple questionnaires and supported asynchronous interaction only, without feedback of results.

Release 2 permitted multiple rounds of a questionnaire. Display commands were expanded, and a structure for agenda items was created. A link connection with the conference chairman (or organizer) was made possible.

Release 3 became available in December 1972. It included a simple command language for the conference participant; a detection for loss of carrier, thus permitting the user to terminate a session by simply hanging up the telephone (rather than taking the time to log out); and a mechanism for

adaptive instructions based on skill ratings. A primitive synchronous-conversation program was introduced and was used in real-life tests. Tree structures and file implementation were achieved in this release.

Release 4 marked a departure from the initial approach that had centered on the implementation of the basic questionnaire-type system. Discussion-oriented features (such as automatic message identification by author name, private-message mode, anonymous-message mode, and a host of minor adaptations) opened the way for the utilization of the program for general conferencing. We began exploring alternative display modes for synchronous discussions. The use of the program by ARPANET participants became significant.

Release 5 (in use on ARPANET since October 1973) was the first version that could conveniently support heavy usage by real-world participants. The code had been modified to make the entire program sharable. Performance measurements showed its central-processor utilization ratio to be excellent (one minute of CPU time for two hours of synchronous discussion, per participant). Most command-language features became available to the user within the discussion itself, and use of control characters was practically eliminated. The ability to retrieve and display past entries by date, name, content, and range was made available. At that point, experience with FORUM already included serious utilization by ARPA management and approximately four months of field testing by the Automatic Programming Group at USC-ISI. Network-wide discussions were conducted routinely and included such topics as the design of advanced teleconferencing systems, the transportation/communication trade-offs, and initial exchanges of research information with the Communications Study Group in London.

Release 6, which was introduced on an experimental basis in August 1974 and was tested until termination of the project in December 1974, features a single, integrated command language, a generalization of the concept of a conference to make joint authorship and other management tasks possible, and a scheme for handling private messages in a personal user file rather than as part of the main discussion.

C. THE NETWORK ENVIRONMENT

In attempting to relate FORUM to other types of computer communication, it is helpful to draw up a map of information-exchange modes available through FORUM (Figure 5). A certain mode of communication corresponds to each element in the matrix: Mail is the mode in which one sends a message to another user with delay. A real-time message to a group is an address. A file may be used as a way of sending delayed messages in oneself, and an example of direct communication with one person to real time is a phone conversation. The functions of the FORUM system thus overlap in some areas with those of text editors and mail-distribution systems already available on some computer networks.

The direction of communication is shown across the top. A given message can be sent by user A to user B immediately (column 1), or with delay (column 4). Alternatively, A and B may be in real-time communication (column 3), or in delayed communication (column 6). User A may also receive a real-time message from B (column 2) or a delayed message (column 5). The possible recipients of A's message are displayed vertically; the recipient can be a system, A himself, another individual, a group, or the public at large.

Several limited communication modes were available on the network prior to the introduction of FORUM. We have displayed them in Figure 6A in the form of a single table.

The LINK mechanism is a crude process through which an online user can effectively attach another terminal to his own and send one-line messages across the network. Every character typed is seen by the other person. There is no opportunity for correcting errors and no more than four users can be interconnected. The LINK is useful for such operations as brief messages to the operator.

The SMD (send message) system is intended for use by programmers and specially trained personnel in exchanging brief (usually less than ten-line) statements such as announcements, plans for meetings, etc. The availability of this system has made an impact on management patterns on the network by unburdening executives whose schedules made it difficult to respond to telephone calls or regular mail. SMD is machine-independent in the sense that a message can be sent to a user at any computer on the network where the recipient has an account.

	REAL-TIME COMMUNICATION (SYNCHRONOUS)			DELAYED COMMUNICATION (ASYNCHRONOUS)		
	1 A to B	2 B to A	3 A to B B to A	4 A to B	5 B to A	6 A to B B to A
B is a device	DEPRESS A KEY	RECEIVE A SYSTEM PROMPT	INTERACT WITH SYSTEM	BATCH JOB	BATCH PRINTOUT	
B is the same person as A				FILE INFORMATION	RETRIEVE INFORMATION	INTERACT WITH AGENDA
B is a person other than A	GIVE AN ORDER	RECEIVE AN ORDER	CONVERSE BY PHONE	SEND MAIL	RECEIVE MAIL	CORRESPOND BY MAIL
B is a group	DELIVER AN ADDRESS	LISTEN TO ORAL REPORTS	PARTICIPATE IN CONFERENCE	SUBMIT AN ARTICLE	RESPOND TO QUESTIONNAIRE	ENGAGE IN DELPHI
B is the public	APPEAR ON TELEVISION	SAMPLE ELECTRONICALLY		PUBLISH A BOOK	VOTE IN ELECTION	

Figure 5. Communication Modes

	REAL-TIME COMMUNICATION (SYNCHRONOUS)			DELAYED COMMUNICATION (ASYNCHRONOUS)		
	1 A to B	2 B to A	3 A to B B to A	4 A to B	5 B to A	6 A to B B to A
B is a device	ALL COMMANDS	ALL PROMPTS	ALL INTERACTIVE SYSTEMS	B A T C H	S Y S T E M S	
B is the same person as A				TEXT EDITORS	FILE RETRIEVAL	
B is a person other than A	LINK	LINK	LINK	SND	SND	
B is a group				NLS JOURNAL	NLS JOURNAL	NLS JOURNAL
B is the public				HIGH SPEED PRINTERS		

A. FUNCTIONS SUPPORTED ON THE NETWORK

	REAL-TIME COMMUNICATION (SYNCHRONOUS)			DELAYED COMMUNICATION (ASYNCHRONOUS)		
	1 A to B	2 B to A	3 A to B B to A	4 A to B	5 B to A	6 A to B B to A
B is a device	COMMANDS	PROMPTS	INTERACTIVE SYSTEMS	B A T C H	S Y S T E M S	
B is the same person as A				TEXT EDITORS	FILE RETRIEVAL	
B is a person other than A	FUNCTIONS SUPPORTED					
B is a group	BY FORUM					
B is the public				PUBLICATION SYSTEMS COM		

B. FUNCTIONS SUPPORTED BY FORUM AND INTERFACE WITH OTHER SYSTEMS

Figure 6. Communication Functions on ARPANET
(Gray Areas Indicate Communication Modes Not Currently Supported At All by Computers)

A third means for the communication of information among users of the same machine is the NLS journal. This is a mechanism that accepts as input a structured file produced by NLS. NLS is a sophisticated text editor based on the mathematical concept of *plex*, which is a generalization of a tree structure. The file is treated as an "article" that is disseminated by the system to a list of addressees and is retrievable by them through the text-editor.

Both SND and the NLS journal are totally asynchronous (delayed). The LINK process is exclusively real-time (simultaneous).

One can see in Figure 6B how some of the functions of FORUM overlap with the processes described above, superseding some of them and probably enhancing the usefulness of others. Also obvious in Figure 6B are the clearly delineated interfaces between FORUM and four categories of functions it does not support: (1) computing capabilities; (2) text editing; (3) information retrieval; and (4) publication systems.

These four types of capabilities are available on the network in one way or another, and we have only begun to tackle the problem of integrating them with the conferencing functions. We have, however, taken care to provide FORUM users with transparent interfaces through which they can have access to such systems. They can, for instance, create a "lower fork" of the operating system (giving them access to all the features of the machine) without leaving the discussion activity; they can also save entries from a conference in a personal file for later processing, or submit such a file as a prepared statement into a conference. These features have been available in FORUM since release 5.

The interface with text editors is provided in the design for release 6. The user can modify his entry by simply hitting an ESCAPE key on his terminal and calling a familiar text editor by name, for instance TECO. And finally, we have provided an interface with a voice-communication system that will be described below.

D. VOICE CHANNEL

If a computer-based system is to be truly useful for decision-making purposes, it is necessary to tailor the system to fit the user needs and

Reproduced from
best available copy.

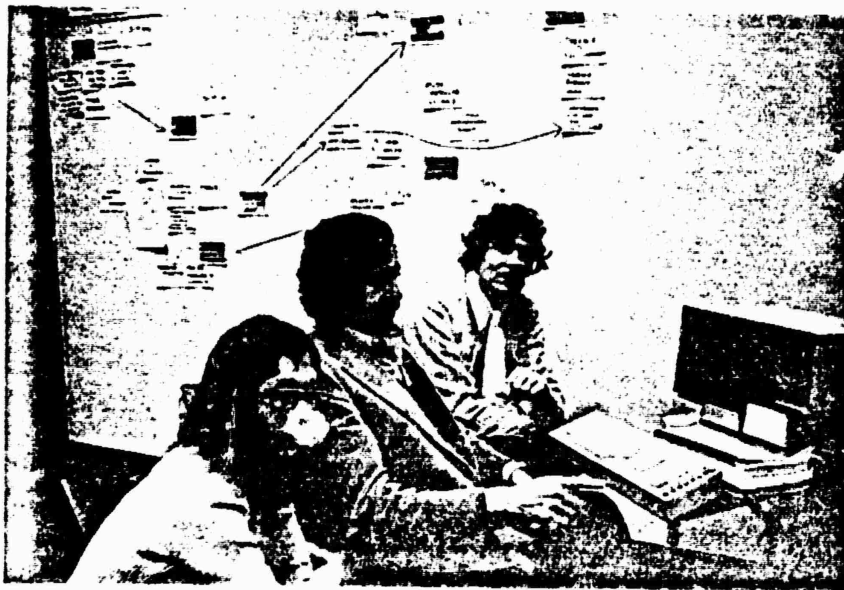

Figure 7. Remote Access to a Computer Conference

Ann McCown, Richard Miller, and Hubert Lipinski are shown here participating in a conference running on a remote computer. A speakerphone is used to maintain a parallel voice connection with other participants.

not require the user to fit the constraints of the terminal. Users are often unaccustomed to using computer terminals or even to typing. To provide comfortable and effective interactive response for people accustomed to secretarial support for converting their thoughts into clear language text, access to communications media in addition to the computer terminal appears necessary. To expect all participants in an inquiry to operate within the constraints of a single computer-terminal system may be unrealistic unless it is possible to achieve a markedly higher, more refined degree of computer/human interaction than that observed to date. Although improved person/terminal interaction is a goal of the present system development, the Institute has not achieved any major increase in the ease of interaction for an unskilled user using the computer terminal. Hence, it appears reasonable to conclude that other media--and especially two-way voice communication--will be more than a useful adjunct; they will be a necessity. We expect initial use of the voice channel to be for the online training of new users of FORUM and for recovery instructions. In addition, we contemplate using it in interviews of the participants during some formal experiments.

The present state of the art of voice-conferencing equipment is not highly developed. Telephone conference calls may be placed commercially (workable with as many as five persons) on a manual basis. Here, as in all present types of conferencing systems, all speakers may talk simultaneously and thus any speaker may interrupt any other.

A more useful system would allow "order wire control" and permit tighter control and discipline, thus increasing the number of users who may simultaneously talk to one another. A search of existing equipment found none that would fit the needs of this project. Hence, it was necessary to draw up specifications for a new type of system.

The basic problem faced in specifying a voice-conferencing equipment design is that there is no single best arrangement. While we do not know the ideal parameter choices for the design, we do appreciate the fact that changes in the communications media can have profound effects on the nature of the communications that transpire.

The precise manner in which the voice system will eventually be used in practice dictates the choice to be made. Yet eventual use cannot be

specified *a priori* at this early stage of development. Hardware constraints must first be determined and the human behavior response operating within such constraints must be tested. Accordingly, we sought to specify a somewhat "universal" voice system in which a wide variety of alternative voice-communication configurations could be tested. Zero cost and infinite capability rarely go together: the more general and nonrestricting the system specification, the more complex and expensive the resulting system design. As a compromise, the Institute considered a set of five representative benchmark designs, or models, in detail. The resulting parameter sets were presented as points from which one could estimate final design specifications, knowing what each specified feature implies in hardware and development costs. On the basis of these five models, one configuration (among many possible hardware configurations) was selected and built. (See the special Institute report by Paul Baran, *Voice-Conferencing Arrangement for an On-Line Interroation System*, March 1973.)

The prototype system which the Institute has tested is designed to place lines in one of two states:

1. monitor only; or
2. talk only (can be used for general broadcast, in which case a line may be connected to all conference paths).

A link is supplied to the system for external connections to a general-purpose computer. The design of the system allows the general-purpose machine to control the system. The switching technology is analog; upgrading of the switch to handle digital traffic, if necessary, is possible. The initial design does not support Touch-Tone from the telephones for system control.

The system was built by Mr. Dean Romein, under the supervision of Dr. David Farber of the University of California at Irvine, and is depicted in Figure 8.

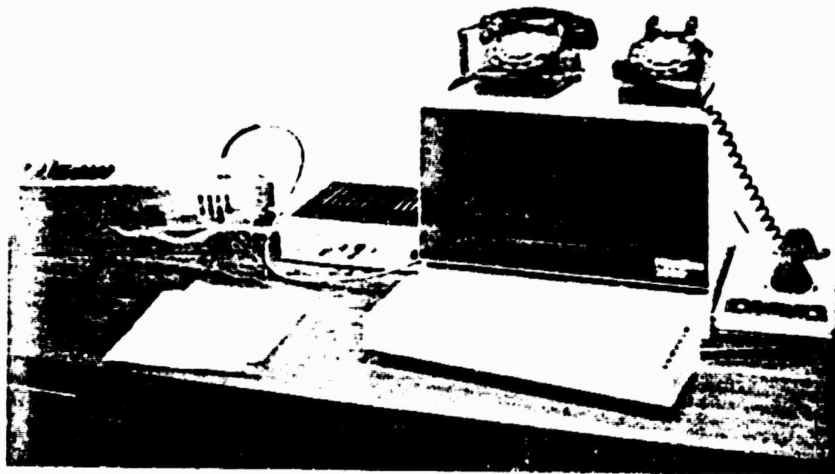
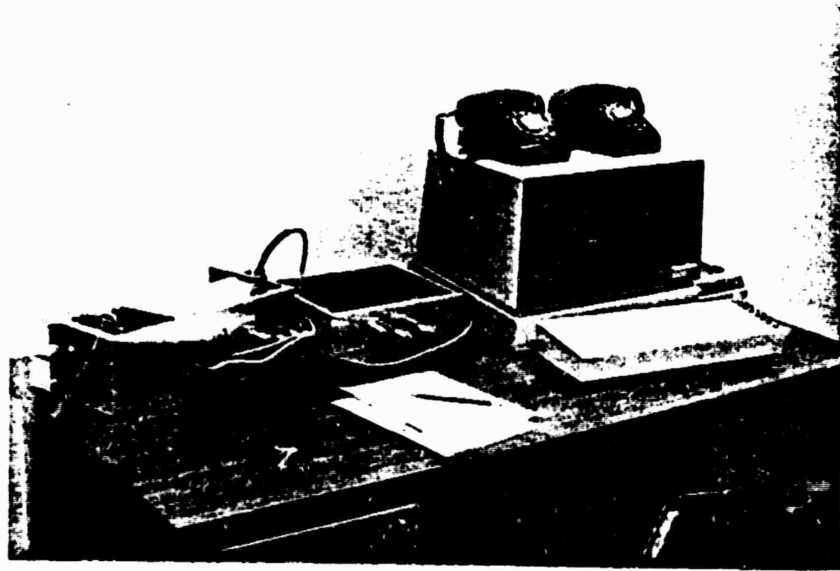

Figure 8. Voice-Conferencing Hardware (Prototype 1)

III. EXPERIENCE WITH COMPUTER CONFERENCING

Since versions of the FORUM program were made available to ARPA management in August 1973 and to other network users in October 1973, actual experience with the system can be reviewed and analyzed. It is important to emphasize that in the present report we are not addressing the questions of psychological and social effects of teleconferencing, which our group is studying separately under sponsorship from other federal and private organizations. We are specifically reporting our findings from three major sources of user information: the data supplied to us by the Information Sciences Institute at the University of Southern California, where FORUM has had considerable application; the various collaborative experiments we have been able to observe; and inhouse experience at the Institute for the Future.

A. CONFERENCING AND DATA-BASE SYSTEMS

As an illustration of actual use of FORUM, we might consider a conference run in May 1973 which linked together the Washington, D.C., Denver, and Menlo Park centers of the U.S. Geological Survey in a series of teleconferences using FORUM-4. (See Figure 9.)

The Denver participant operated a terminal linked to an oil and gas information system resident in INFONET's computer in Los Angeles. A geologist in Menlo Park was operating the DIRAC-2 interactive retrieval system running on the Stanford University IBM 360/67 computer. A data base of Alaska mineral resources was maintained under DIRAC-2.*

The following is a sample of the interaction as it developed in the environment described (the names of the participants have been replaced by single letters):

*This system is described in a paper by Jacques Vallee and Gerald Askevold, "Information Organization for Interactive Use: Design Implications in Data-Base Systems," *Journal of ASIS* (July/August 1973).

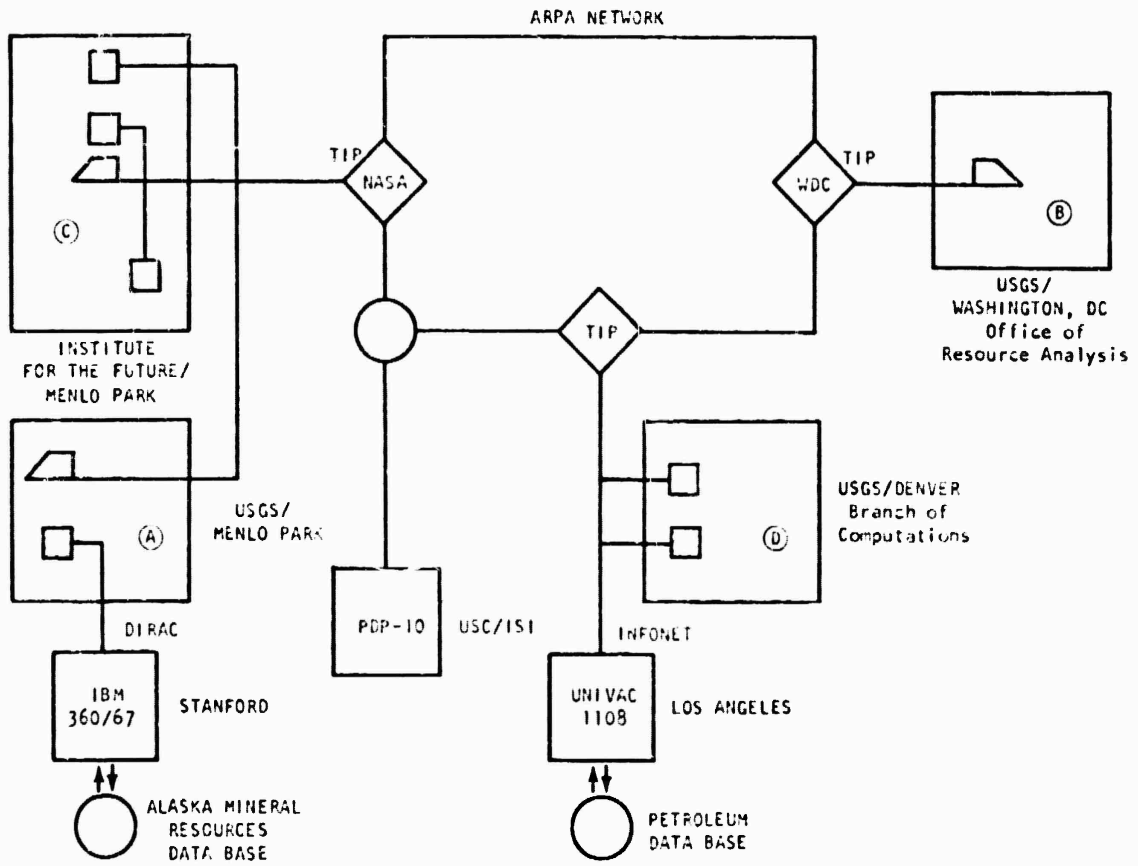

Figure 9. FORUM Experiment on ARPANET With Information Retrieval Coupling (7 June 1973)

- B (Geologist in Washington, D.C.):
To all participants: Please ask your requests relative to the variables listed at the beginning of the session. At this time, I'd like to ask you all to submit the first round of questions (i.e., retrieval criteria).
- A (Geologist in Menlo Park):
To D (Geologist in Denver): How about a list of counties?
- C (Geologist in Menlo Park):
● To B: Let's do a retrieval on pools in Colorado which have a production of greater than 2,000 bbls in 1969 and produce from a type "A" sand.
- C:
● To B: Retrieval criteria production >2,000 producing rock type "A" sand.
- A:
● To D: Did you get our request for a list of counties included in the file?
- D:
● To A: Yes we have the request in the system.
- Institute for the Future:
● I wonder if you can fill this request. Can you give me the percentage of unused oil and gas resources still in the ground (compared to total resources) in your sample data base.
- B:
● To Institute: We will give you the total reserves for oil and gas, and also the total production. The difference is your answer.
- D:
● To B: Here is a list of county names: Baca, Bent, Boulder, Cheyenne, Delta, Elbert, Fremont, Garfield, Jackson, Jefferson, and Kiowa.
- B:
● To all: Please try and stick to the variables listed in the beginning of the session.
● To D: For Institute use variable LIA and LIC for reserves.
- D:
● Nine records were found which had annual production of crude in 1969 greater than 2,000 bbls.

- A:
O.K. D: How about a list of all the oil fields in Cheyenne County and their annual production for 1970?
- B:
To A: Remember that Roger has to type in the output from the search.
- To all: Remember, we can tabulate numeric variables.
- A:
We are now asking questions of the Alaska file asked by interested visitors.
- C:
To A: Can you give us an idea of what is going on?
- B:
To A: There is one pool in the county. The pool name is Mississippian. The production for 1970 was 22,180 bbls. The associated gas production was 800 MCF.
- A:
We are showing Ed and Pauline how the file works. So far they have asked things like: How many properties contain gold and silver?
- Chairman:
To A: What is the nature of the data in the Alaska file?
- A:
To D: Thanks much.
- C:
It is obvious to me that so far this morning we have been able to demonstrate a capability that the Survey has an immediate need for. We have also answered at least 5 letters that normally cross the 5th floor.
- A:
To C: There are no entries with W but we found two that contain silver.
- A:
To C: We are following up on your request.

- D:
To Institute: There are two records in the file with the data for crude originally in place. These two records each show 9,500,000 bbls originally in place and the cumulative production through 1970 was 2,293,336 bbls for one and 184,831 bbls for the other.
- A:
To C: Both are occurrences for which we have no reserve data.
- Neither has significant economic potential.

The participants held a conference call by telephone after the online sessions. The ability (found in FORUM) to link together the resources of several information centers, *possibly operating different computer networks*, was seen by all participants as a concept of great interest.

B. FORUM IN RESEARCH

It is often the case that members of a scientific research team work away from one another and rely on a communication medium to remain informed. Even when no geographical separation is involved, however, a tool such as teleconferencing can provide a convenient way for scientists to pool their ideas and support the research process.

Beginning in July 1973, FORUM-4 and eventually FORUM-5 was used as one medium of communication for the Automatic Programming Group at the Information Sciences Institute (ISI) of the University of Southern California. The research being done during this period involved advanced work in the area of automatic computer programming. The style of FORUM usage which developed provided a kind of collective note pad for the research team. In this application, then, the role of FORUM was quite specific and somewhat limited. At the end of a two-month period, two Institute researchers visited ISI to interview all the participants and obtain their reactions to the medium. The following is a summary of the findings.

There were nine active participants in the research group using FORUM, and they were divided into small topic-oriented groups. Each of these small

groups had individual concentrations, but there was also a strong need to keep in touch with the activities of the other small groups.

FORUM (then still in the early testing stages) was introduced as a possible communications aid by the project leader. A demonstration was given to the research staff at ISI during early June. This demonstration involved a synchronous conference of twelve persons, with no specific topic area to be discussed.

The use of FORUM as a tool in the actual research began without any detailed strategy about the role it would have in the group. The project leader simply began leaving messages in the FORUM program. Gradually, an agreement was made for all members of the staff to check FORUM each day for new information and add their own comments. From this point, they quickly developed the habit of entering summaries of their face-to-face meetings.

Over the period of time described here, FORUM became an important part of the group process. The style of usage which evolved made interaction between groups efficient and provided transcripts as an important written record of the collective thought process.

During the time when FORUM was being used by the Automatic Programming Group, other media of communication were also being used. The media that can be identified as important are:

- face-to-face meetings of small topic groups (usually held daily) and of the entire research group;
- FORUM in an off-line mode, using hard-copy transcripts of the information entered into the system;
- informal meetings among staff members (e.g., those with adjoining offices);
- other computer-based media, such as messages sent through network mail, copies of documents stored in files, etc.; and
- FORUM in an online environment using cathode ray tube terminals (used mostly for skimming the text of other conferences and inputting reactions to hard-copy transcripts).

The FORUM discussions were used primarily to store and distribute working notes. These notes consisted of summarized thoughts, notes of meetings, synopses, and the additions, corrections, and comments which referred to the

summaries. The notes were not of a particularly polished nature, but were generally the "filtered" results of longer, more intense face-to-face meetings. Occasionally, a new or rather unrefined idea was put into FORUM discussions in an attempt to receive feedback and reactions. This feedback, however, was rarely entered into a FORUM discussion.

The responses that were put into FORUM were generally triggered by hard-copy transcripts of discussions which were created as special computer files (in TENEX), edited, run off in multiple copies, and distributed daily. This organization and distribution of hard-copy transcripts was done by a very competent editor-secretary, and was not done within FORUM. It is our plan, however, that FORUM will gradually adopt much more of this editorial function in the future.

In keeping these running summaries and synopses, the records were detailed enough to: (1) allow communication between groups; (2) allow a newcomer to the group to read a history and catch up on the research status of the entire group; and (3) allow the various groups to create reports, papers, and more polished summaries of the work conducted during the period in which FORUM was used.

The research group at ISI was formed just before the use of FORUM was begun. Six of the nine active participants were graduate students, and half of those graduate students were there for only one summer. Only basic user-profile data are available, though, and there was no attempt to do any formal group analyses as either pre- or post-tests. Thus, we can only relay information on the subjective assessment of the group members as they attempted to sort out the effects which FORUM had on their research team.

The general reactions to computer conferencing, limited to structured asynchronous applications, were positive. Most participants felt that this was an appropriate limitation and that computer conferencing would, in fact, be most beneficial in highly structured situations. (It should be noted that synchronous conferencing was not attempted by the whole group, or any of the small groups, after the initial demonstration, in which there was general disappointment.)

There was a generally negative reaction to the necessary reliance on typing ability. This was a problem for five of the nine members of the group and may have affected the usage of FORUM which developed.

The comments regarding specific characteristics of FORUM seemed particularly thoughtful and sometimes imaginative. Since the participants were all highly skilled computer users, it is perhaps not surprising that much of their attention was focused at this level. In general, the group was impressed with the simplicity and general friendliness of FORUM. However, this basically positive reaction was tempered by numerous suggestions for modifications of the structure of the system. Apparently the version of FORUM being used at that time was alluring enough to whet their appetites for computer conferencing, but left them frustrated at certain points.

The most obvious weak point, felt unanimously, was the pressing need for at least basic abilities in text editing and review of conference proceedings. Suggestions for improvement included adding the ability to input directly from a text editor outside of FORUM, allowing persons to rewrite and/or add postscripts to their own earlier comments, allowing comments to be inserted into previous text, abilities to search the text according to various criteria, among others. Most of these suggestions have now been incorporated into release 6.

One of the more provocative suggestions dealt with the ability to alter existing text (specifically, to change one's earlier comments). In its present form, FORUM has an implicit reverence for comments entered by an individual. These entries are indiscriminately frozen in the form in which they are entered. Certainly this practice has a real value if one wants to review the chronological development of a conference. However, in other cases, this might place unnecessary pressures on each user. (What you say had better be good, because it's going to stay there!) The ISI people suggest that some flexibility should be considered, and indeed FORUM now allows increased freedom in this regard.

Most of the group members had adjoining offices and they saw each other daily--usually in face-to-face meetings--to discuss the research. The basic relationship between FORUM and these face-to-face meetings is discussed in the following comments:

"The main issues in the group were not really discussed in FORUM. FORUM was sort of the key that started the interaction. (It showed where ideas were coming together or diverging.) It kept people out of everybody else's hair. We were able to work independently. I

think we got about three times as much work done because of this. But it's so hard to know what the effect of FORUM was because we were interacting in so many different ways at once."

"In general, when we talked, we talked face-to-face."

"I have this feeling that it has cut the face-to-face communication (at least for me). And the communication is still quite adequate."

"Having this feature [FORUM] really was a nice addition to the group, and I think it kept them moving pretty well."

Since FORUM was rarely used as an interactive medium in this particular case, its effects on group dynamics were necessarily indirect. Distribution of the hard-copy transcripts encouraged this noninteractive style. FORUM still had an effect, but it came in such areas as the following:

"I can't think of any effects on the group which actually came from FORUM usage, except that we have a good transcript. It makes writing the report much easier."

"One of the uses for the thing [FORUM] is in the ability to catch up with the progress of the group for newcomers."

"FORUM structured things much more explicitly."

"You don't get the personality conflicts in FORUM that you do in face-to-face meetings."

"I didn't see too many individual things going into FORUM which hadn't been tested out in face-to-face meetings. A lot of what went into FORUM was well filtered by individual group meetings. Occasionally somebody would put in a response, but the things which were put in were usually hashed out in group meetings."

The style of FORUM usage will always affect the kind of group process which develops. In this case, the note-pad style seemed to limit the direct effect of FORUM on the group process. Since little direct communication was done via FORUM, the effects were revealed more in the area of group performance than group dynamics. The group generally felt that FORUM had increased their productivity, though they did not perceive any strong impact on group interaction. The one exception to this observation involved effective communication between groups, which all felt was enhanced by FORUM.

C. INHOUSE APPLICATIONS

Figure 10 shows the development of FORUM usage at the Institute for the Future from August 1973 to February 1974. The purpose of this experiment (in which nearly a thousand entries were recorded) was to use the Institute itself as an initial test of the effectiveness of teleconferencing in long-term group communication. The use of FORUM in this connection was both synchronous and asynchronous, and access was from both home and office terminals.

A special study of an inhouse FORUM staff-meeting conference was conducted by Arthur Hastings, a consultant to the Institute, who analyzed the period from 27 September 1973 to 4 January 1974. An inspection of the transcript suggests that the conference can be divided into several categories relating to the project. These are indicated in Figure 11, along with the percentage of entries in each category.

Different categories might cut across those which are listed, a fact which should be remembered in any appraisal of the use of FORUM. For example, the categories do not fully reflect the social dimension of the exchanges, such as friendly comments and personal exchanges which were often parts of topic discussions. Nor do they specify the actual topics of discussion. However, in examining these particular categories, we can see how the staff used the medium as part of its project responsibilities.

Reports from Staff Away from the Institute for the Future

Two staff members did extensive traveling during the period of this staff meeting conference. They took terminals with them on their trips and submitted reports on their activities from those locations into the FORUM conference. The highest proportion of entries in any category was from such reports. The value of this reporting, according to comments from other staff members, was its immediate availability for the other staff members to read and to offer responses.

This use has the further advantage of enabling the participant to formulate a view of his activities and put them into hard-copy form which is always accessible for his own use. Further, one researcher commented that he and another staff member had attended the same meeting and it was only when each reported on the meeting via FORUM that they realized each had different recollections of some of the events of the meeting.

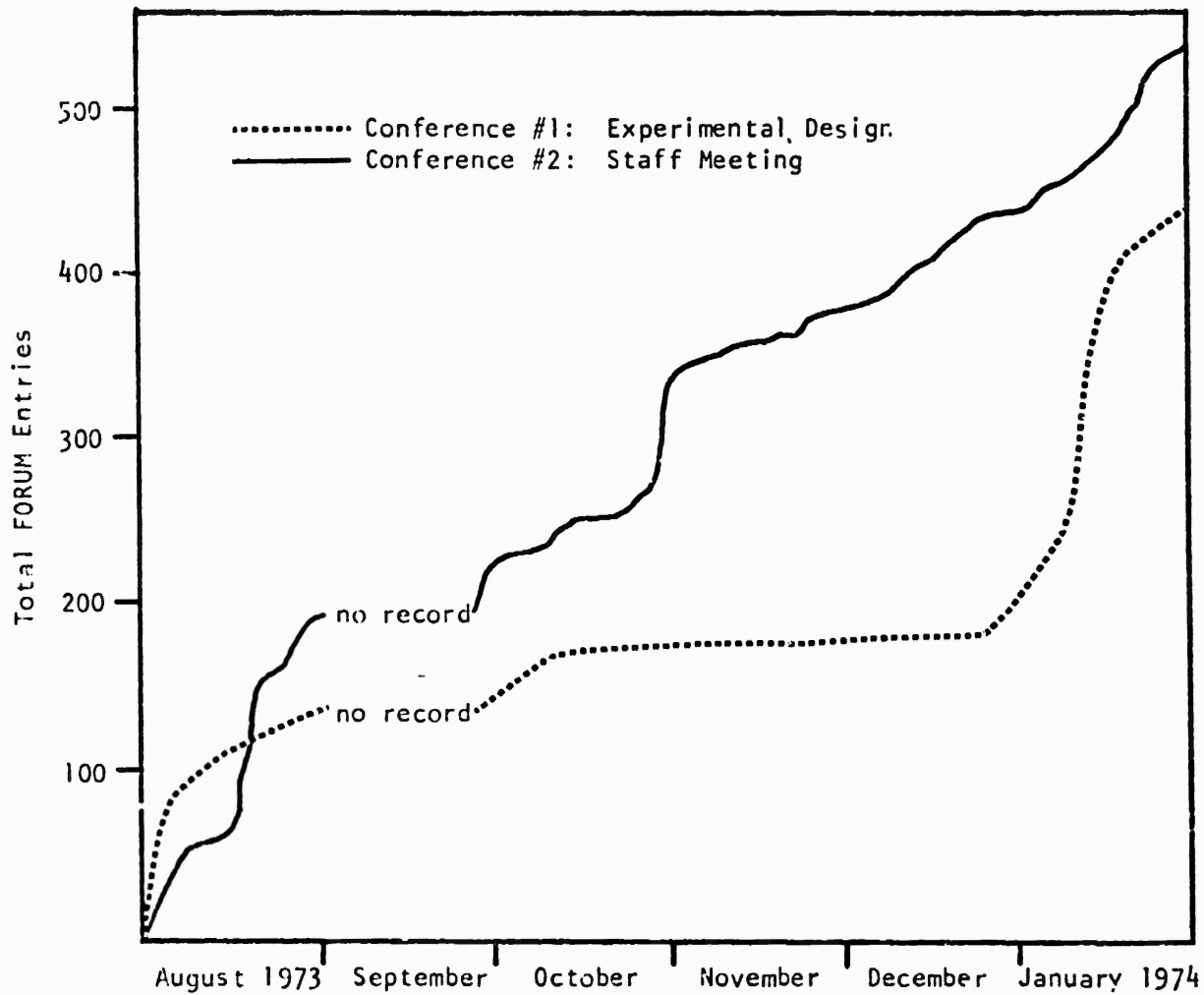

Figure 10. Growth Curve for Two Institute Conferences

Reports from staff members while away from the Institute		38.3%
General comments	8.3%	
Conference reports	5.0	
Meetings with researchers	20.0	
Funding agencies, public relations	5.0	
Operations of the project		32.2
Log of project activities, records		14.5
Meetings with other researchers (at the Institute)		6.1
Personal		8.9
		<hr/>
		100.0%

Figure 11. Categories of Entries in a FORUM Staff Conference

One qualification can be made regarding this form of reporting: At the time the entry is made, there may not yet be a perspective from which to judge its usefulness, so the transcript may be filled with entries which are of little use to others. To avoid this, it would seem possible to hold pre-travel discussions among the staff to prepare for what might be reported and to engage in dialogue and responses to reports from traveling staff members as they are made in the conference. This feedback would make the reports more useful to the staff members in the office and would help the traveler to know better what areas of his reports are receiving attention.

Operations and Management of the Project

Operations and management of the project were among the major purposes for which FORUM was used. Of course, since the members of the project staff were all in the same suite of offices, much of the coordination of the project occurred through face-to-face meetings. For example, researchers in the same office would naturally share information directly. To use FORUM in such a situation would have been artificial. Also, there was no enforced use of FORUM during this trial period, partly because the network was unreliable.

Even with these basic circumstances, the system was used for many aspects of project coordination, such as setting up an agenda for a face-to-face staff meeting, verifying locations of terminals, and discussing plans for a teleconferencing workshop which was held at the Institute. It was used for giving instructions, for passing information to one person or the group, and for stating rules, plans, and intentions in writing. When one or more of the staff members was traveling, FORUM was sometimes used to meet project-management needs.

However, primarily because of the proximity of the staff members' offices, FORUM was generally used for the less urgent matters which required less interaction. Frequently, FORUM was used as a log of what had happened on the project, serving as a common file for the staff members. Typically, staff members would report a meeting with a job applicant, describe an Institute staff meeting, report on a meeting with a sponsor, discuss trial sessions using graphics facilitation, and other such matters. Some of these log reports were about activities of the project per se, like a historical

record, while others were reports of one person's activities which were of relevance to the rest of the project staff. (Some of these reports overlap with the "operations" category, of course.)

It is not clear from discussion with the staff members how much these entries were used, but they could serve as an open file which could be reviewed for any one topic, and participants reported doing this on topics of interest to them. The log would be particularly useful as a common-memory file, where one participant could gain access to the activities of another staff member by reviewing the conference entries. Over a period of time, the transcript would become an invaluable document which could be reviewed periodically during the project on a semiregular basis.

There were three principal kinds of entries relating to the FORUM program itself. The first was a discussion of potential design features of the program, e.g., the discussion of monitor and overview capabilities. The second category consisted of announcements of implementation, changes, and features of the program. A third category had to do with problems, bugs, and questions. The transcript also contains comments on such topics as passwords, the network, terminals, and the warmth of the FORUM program for new users.

Often other researchers in the field of computer conferencing would visit the Institute offices, and these visits were usually reported in the conference. Entries thus made would again serve as a memory record for the group's activities and provide references to research activity relevant to FORUM. (These could be included under "log of activities", but they are enumerated separately to show the comparison between research meetings which occurred on trips and those which occurred at the Institute offices.) Thirty-six of the travel entries reported on research and researchers in comparison with eleven at home. As reflected by these entries, travel was a rich and compelling source for these matters.

In the "personal" category falls a variety of greeting and personal comments. There were probably many more than appeared in the transcript, because these kinds of messages were usually sent in the private mode and thus are not in the conference record. They are probably essential to FORUM conferencing, however, because they are ways of making a written mode more personal.

Styles of Discussion

In this transcript, individual staff members tended to be consistent in their style and choice of subjects, although there may have been some adaptation to the knowledge that what they were writing would be read by everyone (and perhaps by those not even in the conference). The most obvious mark of individuality was in the choice of subjects. As discussed earlier, each member of the project had particular responsibilities on the project, and each person's entries tended to emphasize his area of responsibility.

Length of entries is another characteristic in which individuality is shown. All the staff members broke up long entries into shorter ones, usually according to paragraphs or topics. This was also a function of the subject itself, but the individual's preference for entry length did seem to be stable.

Most of these entries were made in the asynchronous mode: they were entered into the transcript when the participant was the only person present (or when less than the whole group was present) and were read at a later time by other participants as they entered the program. Although there were several synchronous discussions (with two or more participants present at the same time), the staff meeting conference was primarily asynchronous and served more as a discussion and log of individual activities.

Decision-Making

The following decision-making issues were discussed in FORUM during this period:

- monitor and overview capabilities of FORUM;
- exchange of papers on Communications Studies Group;
- mailing list and bibliography; and
- facilitator for teleconferencing workshop.

These were relatively minor decision matters and very few in number, considering the range of decisions that the project faced through the time period of the staff meeting conference. For example, action decisions by the project staff included the hiring of a new staff person and the design of release 6. Nothing regarding the former was mentioned in the transcript.

entries on release 6 included announcements of face-to-face meetings to discuss the language structure and planned features. Any discussion that went into the choices and design occurred outside of the transcript.

Conclusions on Institute Usage

For a number of reasons we have found it convenient to use FORUM in our own work. A major purpose of the Institute is to organize, structure, and improve the collective work of groups of experts. The probability-estimate elicitation and forecasting features of FORUM are being used in several projects dealing with future trends in communications regulations, with the chemical industry, and with the telephone industry. In the study of communication trends, the panelists were called upon to make projections of a number of trends, and all probability estimates were processed using FORUM subroutines. In this application, the probability density assigned by each respondent was corrected according to his estimating ability and weighted according to his degree of expertise in order to arrive at a group estimate.

Another application of the FORUM system in open-discussion mode was the maintenance of contact with staff members during periods of travel away from the Institute. One researcher, who formally joined the staff in July 1973, actually participated in a number of meetings and made valuable contributions to the project during May and June 1973, while he was still residing in another part of the country. On another occasion, one staff member was visiting a Massachusetts computer company and needed specific data. He was able to obtain it by joining an ongoing FORUM meeting involving several researchers in California and New Jersey. This led to an immediate exchange of information that might otherwise have been lost.

Although many of these observations are anecdotal, one point of special interest in such staff-meeting situations is the fact that FORUM makes it possible for management decisions regarding current and future plans, schedules, and assignments to be kept for future reference *in the context of the discussion in which these decisions were made*. The ability to refer to such a transcript later is invaluable.

The inhouse use of FORUM also revealed the change in life style that such a medium makes possible. Better utilization of personnel and computer

time and the ability to extend the range of environments in which an individual staff member may work without losing contact with the team are some of the advantages that point to the feasibility of applying future versions of FORUM in the general office environment.

More significant than synchronous usage among the staff was the experience the Institute gained in conferencing with other groups. A number of synchronous discussions was held with other scientists, both to introduce them to the concept of teleconferencing and to discuss substantive research issues of common interest. An example of such a conference is given below. The participants involved here were Jacques Vallee and Richard Miller of the Institute staff and a geologist referred to as "A" who was in the office of another geologist referred to as "R". The discussion was as follows:

- MILLER (Chair) :
 - I thought that before we discussed the applications of FORUM, we might talk briefly about interpersonal communication via a teleconferencing system.
 -
- VALLEE :
 - How do you mean that, Rich? As a way of linking members of a professional community?
 -
- MILLER (Chair) :
 - Yes.
 -
- A :
 - I'd like to interject a reaction by Mr. R to the proposed agenda.
 - He feels that the most important question in something like his program is the necessity to draw in many people who have no experience with computers or "gadgets"--that the process has to be at a personal level, rather than at a mechanical level. Therefore,
 - telephone may be a necessary way to break the ice and leave new users with the idea of an impersonal method.
 -
- VALLEE :
 - After the experiment we did last week (in connection with data bases) do you feel the parallel voice channel helps in solving
 - this "breaking of the ice" problem?

- A :
● Let me correct my last sentence by saying I meant NOT to leave
● new people with an impersonal feeling until they get into it.
- A :
● I don't think there is a parallel, because I was quite used to
● the system.
- A :
● Mr. R corrected me in that the telephone is impersonal to a degree
● also...it's more a matter of moving from levels of "familiarity".
- MILLER (Chrmn) :
● But I was not used to the GRASP system. And I thought that the
● use of voice was a help for the first ten minutes or so, since the
● use of the GRASP system became pretty clear to me after that amount
● of time. After the first ten minutes, the voice channel was not
● necessary.
- VALLEE :
● Yes, you were used to the system, but I wasn't used to YOURS in
● that case, and the explanations given over the phone DID help in
● straightening out some retrieval problems.
- MILLER (Chrmn) :
● If this is the case, what is the solution? A meeting of the par-
● ticipants in face-to-face conversation before using either the
● telephone or teleconferencing for group discussion?
- VALLEE :
●Or a picturephone-type device that enables you to establish
● visual contact with the other person?
- A :
● Mr. R feels that initially visual contact would be ideal, but af-
● ter brief exposure may be no more necessary than a phone conversa-
● tion in this same context. Face-to-face could be the most desir-
● able, but may not be practical.
- VALLEE :
● Based on our experience so far, we feel that FORUM will obviously
● not replace face-to-face conferencing, but rather will enhance its
● efficiency...
- VALLEE :
● By this I mean that participants who have already put their main
● ideas on record via a FORUM-like system can skip all the prelimi-
● naries when the time of the face-to-face meeting comes, and they

- can get to the really substantive issues right away. In ordinary conferences, as we know well, it takes two or three days of discussions to reach that point.
- MILLER (Chrmn) :
Also, this implies the practicality of the system for pre-formed work groups. For example, if the project staff has met at some time to delineate the general problem or task, they have a feeling for the individual personality of their partners and can forego the telephone conversation or face-to-face meeting that precedes the initial session of a new work group.
- MILLER (Chrmn) :
This is why I think that the FORUM system has applications for projects with a staff that knows each other and which communicates by other means besides FORUM.
- A :
If you are wondering what the delays are due to here, we are discussing various problems and ideas that are prompted by the "FORUM" discussion.
- MILLER (Chrmn) :
We were just discussing the fact that we were probably losing the most interesting information that you were producing, in that the discussion that you are having is not being recorded or transmitted to us.
- A :
Mr. R is largely in agreement with the above points. He would further suggest that this seems to be an argument for internal use vs. some type of public or outside use. Comments?
- A :
That is probably true...unfortunately, you will probably have to rely on my demonstrated faulty memory to relate some of what transpired.
- MILLER (Chrmn) :
Public use implies a lot of problems that we have no means to evaluate, at least right now. The internal use also fits our description and impression of FORUM as a complementary medium of communication, rather than the sole means.
- VALLEE :
I think the STRUCTURE of a given discussion determines where it is placed in the spectrum from private (internal) to public.

- VALLEE :
Of course, when a tool like FORUM is used as a front-end to data-base software, the picture changes completely.
- A :
Jacques, please expand on this last point (or elucidate).
- VALLEE :
For internal use you would expect to have well-defined agenda and applications like remote budget preparation, policy formulation, etc., which implies structuring (questionnaire-type or otherwise).
- On the other hand, public use implies a very loose structure of the type we are now using, where anybody can talk at any time, and subjects are only determined by consensus.
- A :
Mr. R states his primary concern is more with communication with a special segment of the public, i.e., city, county, and state planners and decision-makers who have need of USGS data and information, but do not know our language or how to obtain the information they need.
- A :
Structure comes through now, Jacques. Thanks.
- MILLER (Chrmn) :
But if they are in dialogue with a member of your group, even if the means is FORUM, don't they have access to the terminology and to aid in making requests?
- A :
In reply to your comment, Rich, he says that this follows. But he would add that history has shown that "expert" professional scientists such as we have here are greatly remiss in communicating with others. He feels the main challenge of his project would be one of "compressing" large volumes of data in a "digestible" and meaningful form for the person who would have use of the data (change "remiss" to "awkward" or "clumsy").... This implies large use of graphic and map-like displays.
- A :
However, there is no way to avoid the use of large bodies of words also. I should add that Mr. R's principal interest is NOT in improving the organizational efficiency or effectiveness...there are a number of others who have this as a primary concern. He is, as I think has become apparent, more interested in the "public" that the project serves.

- VALLEE :
Can one do what you propose by software alone? It seems that it
- will not be enough to give people access to the data, you have to
- give them a simple link to someone who can interpret the data for
- them.

- A :
Exactly so, Jacques.

- A :
This leads Mr. R to feel that the REAL potential with something
- like FORUM would be to link the local "expert" or would act as a
- link between the local expert and larger systems or other experts
- and the person in need of information.

- MILLER (Chrmn) :
That sounds like an information clearinghouse for geologists. Is
- this function needed often in the time frame that FORUM provides?
- That is, how often is dialogical real-time communication of this
- type necessary in your group or by your group for the outside
- public?

- VALLEE :
Remember that the problem calls for more than a traditional
- clearinghouse. The question from a user might involve more than
- can be answered locally. Having an on-line community of experts
- would make it possible, say, for an expert in Washington to reply
- to a question from Texas.

- A :
Rich, Mr. R states that we are looking more at an ENVIRONMENTAL
- CLEARINGHOUSE RATHER THAN A PURELY LOCAL ONE. Most of the dead-
- lines are in a time framework of months; (e.g., for planners and
- decision makers) rather than rapid turn-around.

D. FORUM CONFERENCES ON THE ARPA NETWORK

Figure 13 shows the growth of two user conferences that were set up on ARPANET in October 1973 for the purpose of exploring the software issues raised by FORUM with interested and competent parties at various ARPANET sites. These two conferences were created on the basis of our experience with a wider, public exchange that had taken place in August and September and had involved a very large range of reactions both to FORUM itself and to the overall context of teleconferencing. With the availability of release 5 of FORUM in October, this public conference was discontinued and

replaced by two specific discussions among a smaller group of participants who were directly involved in teleconferencing at the design level. The conference shown in Figure 12 as "USERS: 1" dealt with specific reactions to FORUM and was limited to contributors with many hours of actual experience with the medium (most of them were from USC/ISI), while the "USERS: 2" conference centered on the associated design problems.

During the period of October to February shown in these statistics, participants using the two conferences made a total of 380 entries. The rate of increase in the number of entries is again correlated with the synchronous nature of some phases of the discussion, as reflected especially in the USERS: 2 conference for 9 January 1974, when three users exchanged design ideas in a fast brainstorming session.

Typical of the synchronous exchange is this part of the transcript, in which two users, who had previously been arguing in asynchronous mode about conference structures in FORUM, happened to be on the system at the same time. (The reader will notice that, unlike preceding examples which were based on FORUM-4, the messages here are numbered and have date and time stamps. These features were added in release 5.)

- [71] MILLER(Chrmn) WED 9-JAN-74 5:47PM
Hi Wally. What would you like to talk about?
- [72] RYDER WED 9-JAN-74 5:47PM
- Rich, I think I would like to address an earlier entry I made on security first. Because of the variety of different sources and kinds of sensitivities to information, it seems that unless a similar variety of security measures is available important stimuli are not going to be broadcast over this medium.
- [73] RYDER WED 9-JAN-74 5:51PM
What I propose is a discussion of the variety of security measures that might be provided.
- [74] MILLER(Chrmn) WED 9-JAN-74 5:52PM
R 72
- I agree. Have you been advised as to the security measures that are being taken in release 6?
- [75] RYDER WED 9-JAN-74 5:53PM
- No. Or rather only briefly. Can you help me?

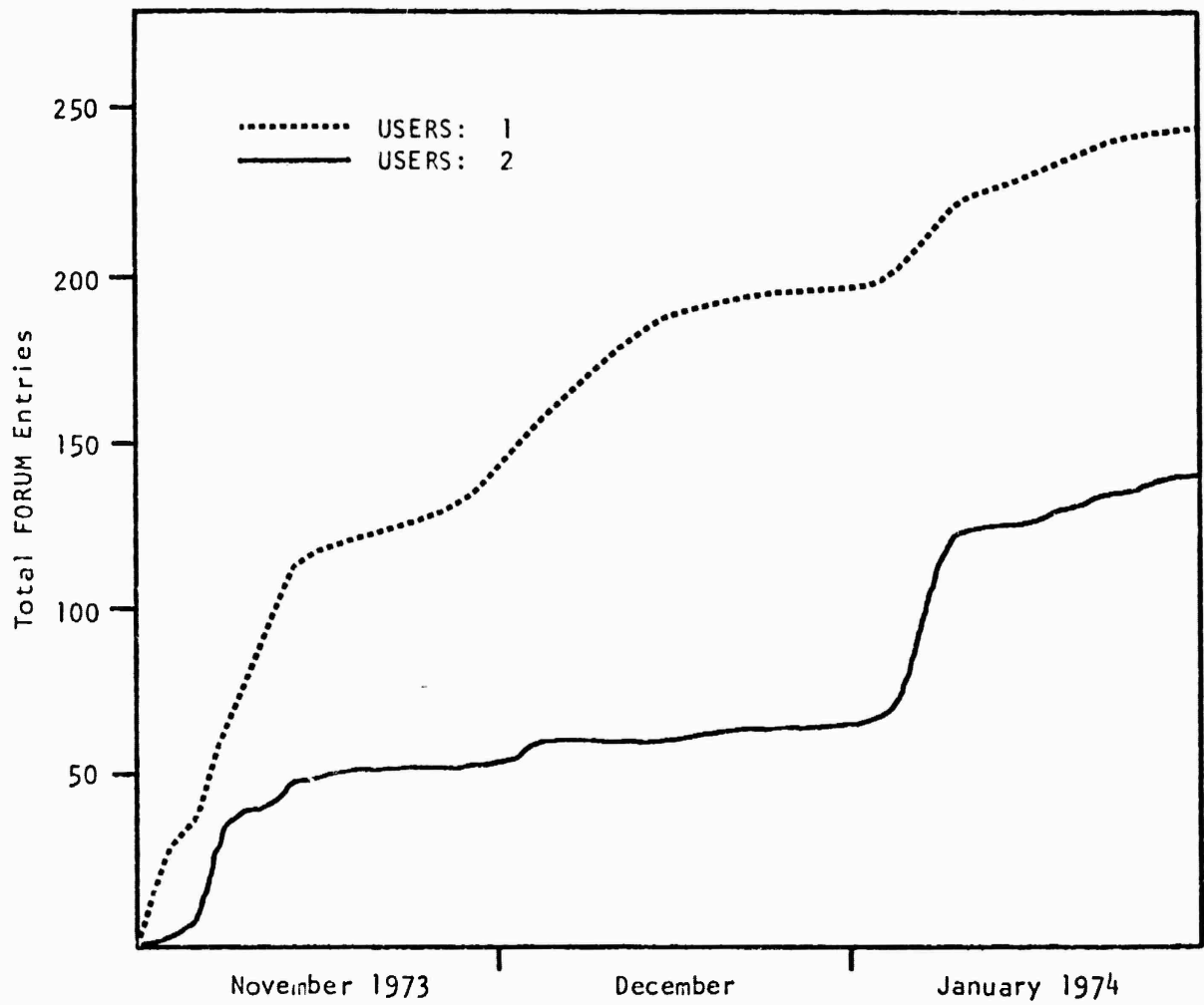

Figure 12. Growth Curve for User Conferences

- [76] MILLER(Chrmn) WED 9-JAN-74 5:54PM
Yes. Let me outline what we've got in mind and then you can tell me what we've left out.
- [77] MILLER(Chrmn) WED 9-JAN-74 5:54PM
First, release 6 will incorporate a password system such that each user will have a unique password under his control and which will allow access only to those persons who know the password. A private message file will be constructed for each user, so that they are retrievable and deletable under the user's control.
- [78] MILLER(Chrmn) WED 9-JAN-74 5:57PM
The new system will allow any user to set up a conference, so nobody from the Institute even has to know of the existence of a conference. There will still be the problem of getting a text file dumped out which will contain the text of a conference but the only people who will be able to do this will be people with "wheel" capability and those programmers at the Institute who know the location and the password for the directory that holds the conference files.
- That's about it. Should I be more specific?
- [79] RYDER WED 9-JAN-74 6:04PM
How do you plan on handling the problem of different levels of clearance within a set of participants?
- [80] MILLER(Chrmn) WED 9-JAN-74 6:07PM
The only "clearance" capability is the following: you can create a discussion within a conference and "deassign" that discussion for a participant. In other words, you can send private messages to a group of participants in a discussion or you can lock a participant out of a discussion altogether.
- [81] RYDER WED 9-JAN-74 6:12PM
I wonder how to evaluate the cost of not having "all" participants be able to respond to whatever stimuli they are permitted to see, especially in a non-real-time medium like this. It seems that mask, might be able to buy back some of that.
- [82] MILLER (Chrmn) WED 9-JAN-74 6:15PM
Hold on. Phone call.
- [83] MILLER(Chrmn) WED 9-JAN-74 6:19PM
Wally, what type of "classified" message system would be more suitable?
- [84] RYDER WED 9-JAN-74 6:21PM
Let me try to explain my simple model of the system. Unless I'm

- just using the conference to inform, the fundamental purpose is to make concepts articulate. For that purpose, and because we are
- so ignorant of the mechanisms that make that process work, when it does, and to whatever degree it does, the closer to a shot-gun approach you take to provide as many servers that stimuli, the better. Think of it as a queueing problem. As a consequence, if the
- different kinds of information were coded according to who can read it (the classical problem of classification, except this can
- always be done, if desired in small packages) then as many servers as possible (out of the original set) could respond.
-
- [85] MILLER(Chrmn) WED 9-JAN-74 6:32PM
- Are you talking about who gets the entry or how soon one gets the entry when you mention the queueing problem? If it's the latter,
- I don't know the answer other than sending private messages with the higher priority and regular messages with the standard priority.
-
- [86] RYDER WED 9-JAN-74 6:35PM
- What I meant by the queueing problem in [84] is:
 - 1. Stimuli representing concepts to be discussed are generated by participants. These are to be processed by other participants in one or more of several ways (e.g.: (a) acknowledged that the representation adequately covers the concept and agreement (understanding) is accomplished; (b) the representation of the concept is inadequate, and paraphrase, refutation, or some other appropriate response is generated; and (c) a new concept is triggered in the mind of the receiver, and he begins to attempt to articulate it).
 - 2. The receiver responds to the stimuli (i.e., the demand is serviced).
-
- That's the queueing system I had in mind.
-
- [87] MILLER(Chrmn) WED 9-JAN-74 6:46PM
- I see, but what prevents that type of use now in FORUM? If you want an automatic chairman that operates under modified Roberts
- Rules of Order, one could structure the interchange with giving the floor to a participant, allowing questions and challenges,
- etc. but I have the feeling that this solution would be more cumbersome for the task at hand.

After this synchronous exchange, a third user came into the system, and as he reviewed the past entries to catch up with the ongoing discussion, the first participant had to leave. The conference continued as follows.

- [102] MILLER(Chrmn) WED 9-JAN-74 7:24PM
If what you are saying has penetrated my thick skull, you want something that would allow me to designate groups of participants and then send messages to groups at my command, like (to group,!) but not group 2, or to groups 1 and 2, but not group 3. Right?
- [103] VALLEE WED 9-JAN-74 7:26PM
Sounds like it requires an IDENT system.
- [104] RYDER WED 9-JAN-74 7:27PM
RE: 102 right. RE: 103 ident? Help me.
- [105] VALLEE WED 9-JAN-74 7:28PM
This implies a sophisticated mechanism for identifying everybody. We have tried not to introduce a concept of large user file in FORUM.
- [106] MILLER(Chrmn) WED 9-JAN-74 7:29PM
I'm afraid I'm going to have to quit this for now.
- [107] VALLEE WED 9-JAN-74 7:30PM
Wally, I haven't caught up with the previous discussion yet, but are you suggesting that a mechanism should exist for designating subgroups within a conference? Across conferences?
- [108] RYDER WED 9-JAN-74 7:30PM
RE: 106
I understand, I'm beginning to get giddy myself. I really can't stand typing. Thanks Rich. Good talking to you.
- [109] RYDER WED 9-JAN-74 7:32PM
Both, J., I'm concerned with obtaining the maximum flexibility in a security mechanism without having to write the number of respondents that can serve an entry.
- [110] VALLEE WED 9-JAN-74 7:36PM
Is this in the context of a discussion with human users or of a simulation or model building? In the case of human users there is a danger of such a mechanism getting in the way.
- [111] RYDER WED 9-JAN-74 7:37PM
RE: 110
Human users. I don't know how much the "getting in the way" is a tactical design problem. Security problems themselves inhibit communication. What I am concerned about is an articulation of the trade-off that is inputted in any system between the complication of the security mech. in the system, that that covers for the lack of one in the user's mind, and the cost of failing to have one because it wasn't covered anywhere.

- [112] VALLEE WED 9-JAN-74 7:44PM
RE: 111: How do other participants become aware of a group's name, existence? Is this a chairman (or what we now call "organizer") function?
- [113] RYDER WED 9-JAN-74 7:46PM
RE: 112
Sure. I don't know what would be the matter with letting the organizer be responsible for which combinations of participants had what security options.
- [114] VALLEE WED 9-JAN-74 7:47PM
RE: 110
I can see more need for this in modeling where group names might designate sets of modules under program control.
- [115] VALLEE WED 9-JAN-74 7:50PM
Should the organizer be the only one though? Why not let every user designate the groups he can address his messages to? I wonder what a facility like that would do in a synchronous discussion. It might encourage fractioning of the main conference and some users would gradually get the feeling of being "left out", probably rightly so! In asynchronous mode, though, this would be a nice way to have a notification system. We have to think about that one.
- [116] RYDER WED 9-JAN-74 7:52PM
RE: 114
That's interesting; I hadn't considered it. Isn't it a different security problem?
- [117] VALLEE WED 9-JAN-74 7:55PM
RE: 116
Same basic problem, I think. Under release 6 participants will manage their own private-message file, so the burden for protecting the file is on them.
- [118] RYDER WED 9-JAN-74 7:56PM
RE: 117
That should answer part of the problem on this system, if they ever handle the "group" code problem.
- [119] MILLER(Chrmn) THU 10-JAN-74 10:39AM
To all participants:
● Does it meet with anyone's approval or disapproval to set up an additional activity on the subject of security and malleable patterns of interconnection, as was suggested in the conversation among Messrs. Ryder, Vallee, and Miller? Please let me know soon, since I'll set it up if I don't hear any grumblings.

- [120] VALLEE THU 10-JAN-74 11:00AM
- Rich, an alternative to setting up another activity might be to
- just identify this as a theme we could refer to in later discus-
- sion. Having to go into another activity is quite constraining.
-
- [121] MILLER(Chrmn) THU 10-JAN-74 11:04AM
- I agree that it is a constraint to subdivide the discussion, but
- there seems to be a problem with mixing all the discussions into
- one giant heap. Possibly we should wait for a while to see how
- the discussion goes. One thing that might solve all the problems
- is a means of putting in an "expanding table of contents" such
- that users would know at a fast glance where the discussions rel-
- evant to their immediate interests are. The review by first n
- lines helps, but doesn't do the full job.
-
- [122] GREENFELD THU 10-JAN-74 11:19AM
- One can look on the confused threads of the past 40 messages as a
- very good example of the needs and operational characteristics of
- a teleconferencing system. At some point, (I believe about mes-
- sages 110), the impatience with the medium became so great that at
- least 2 splinter conversations got started. While it may have
- been understandable to the participants (was it?), to a later ob-
- server it is difficult.
-
- I should think that the need for very flexible structuring in all
- the guises of "activities" and "message-receiving" groups etc. is
- now obvious. The questions that need discussion are whether these
- structuring methods should be done at the time of message genera-
- tion (e.g., security) or at the time of reception (e.g., current
- string search) or both, or which types of structure which ways....
- That is, this is the kind of meta-structure rule which will de-
- termine whether the structuring activities will "get in the way"
- or be enhancing of communication.
-
- [123] MANN THU 10-JAN-74 3:29PM
- There are applications for post hoc topical structure as well as
- on-the-fly organization of activity. For example, I may want to
- review a series of suggestions via a structure which represented
- whose money was to be spent for each suggestion, even if that as-
- pect never came up. So I may want to impose my own thread struc-
- ture afterwards.
-
- Reviewing by somebody else's thread structure is a useful looking
- index means. It is attractive because FORUM encourages fragmen-
- tation of a discussion rather than serial consideration of topics,
- as would be common in a face-to-face conference. The proper
- thread structure is often one object of negotiation. AN AGREED
- UPON SET OF TOPICS SHOULD NOT ALWAYS BE A PRECONDITION FOR
- PROCEEDING.

The remark by Greenfield (in entry #122) that two splinter discussions took place simultaneously after entry #110 is an observation that can be generalized to most of our synchronous conferences, where participants commonly fall into the pattern of conducting several threads of discussion at the same time. Later identification and review of these threads is an intriguing problem that will have to be faced in future versions of FORUM.

Another user conference was implemented for the purposes of allowing rapid dialogue and solving technical problems between the FORUM designers and the major users of the system. An excerpt that is typical of the discussion is given below as an illustration of the degree of detail of these exchanges.

- [37] BALZER WED 31-OCT-73 4:31PM
RE: Message Presentation
- On entering this conference, I was told that n messages had been entered since I was last here and did I want to see them. I said
- yes, and got them in order correctly except for the last one which came out after the message "YOU HAVE SEEN THE 35 ENTRIES MADE SO FAR(CR) IF YOU NEED HELP..." Not only that, but it (message 35) came out without a time or date stamp.
-
- [38] BALZER WED 31-OCT-73 4:37PM
RE: Use of JOIN Command
- In spite of the message about the use of JOIN (message 33), I just tried it and it was not recognized. On reflection, I assume it is because I have been using FORUM for many hours and my copy is the old unmodified version. If I got out of FORUM and obtained a clean copy, I suspect (and hope) JOIN would be recognized. However, if I were a non-computer user, I probably wouldn't understand about copies of programs and would wonder about the competence of the system builders whose comments about new good features didn't work!
-
- [39] BALZER WED 31-OCT-73 4:43PM
RE: Previous Message
- As I suspected, all is better now that I have the current copy of the program. It works as advertised.
-
- [40] LIPINSKI WED 31-OCT-73 8:33PM
RE: 37 by Bob Balzer on message presentation. Message 35 by Norton Greenfield was put at the same time you were in FORUM, i.e., as you were catching up on the entries you had not seen. Thus FORUM

- did not put a date and time stamp. You caught FORUM at the transition between synchronous and asynchronous operation. In synchronous operation it does not put the time stamps since it doesn't make sense then. By the way the fact that you keep getting the
- "IF YOU NEED HELP" message is a bug. It is supposed to print only the first 2 times you ever use a conference. This will be fixed,
- as soon as I can since it is starting to bother me and I'm sure you also.

- [41] LIPINSKI WED 31-OCT-73 8:53PM
Hopefully the confusion in choosing conferences will be somewhat reduced since FORUM now displays all conferences you may attend, instead of the private and public (that you haven't joined yet) distinction it made before. The ability to obtain direct comments and specific reactions from users of the system shortened
- drastically the reaction time to suggestions for improvement of the system. It also served in increasing the acceptance of
- FORUM among our user population on the network.

IV. CONCLUSION

A. MAJOR FINDINGS

In the course of this project, we have learned how to use a computer network in support of a fundamental decision-making activity, the structuring and conduct of conferences. The research issues addressed in this activity fall into two categories. First, from a computer science viewpoint, the development of file structures to support conferences raises design issues that we have identified and solved in the course of our experimentation. Essentially, the file structures must allow many users to share them simultaneously, and programming of terminal-oriented capabilities must be designed to make the machine as flexible as possible. Second, from a human-factors viewpoint, our research has involved the identification of certain basic principles of communication in the computing environment and the creation of methods for displaying, in a meaningful way, both the contents and the dynamics of the communication.

Synchronous (simultaneous) conferencing poses problems that have not been observed before by computer scientists. Research on conferencing under any communication medium must begin with an understanding of the social processes within which the discussion or encounter takes place. Careful observation of group discussion has combined with tradition to provide certain rules for conducting meetings. Typically reflected in the adversary process of a court of law, in parliamentary debate, and in Robert's Rules of Order, this tradition demands that the floor be given to each side in turn, and provides methods for handling motions, suggestions, and the presentation of evidence. The availability of a computer as a tool to structure this interaction opens up new capabilities. But at the same time, the classical text processing techniques do not satisfy the needs of the participants in such a conference. A programming effort aimed solely at providing users with an array of new commands for indexing, keywording, and defining threads in the course of the dialogue is clearly not the answer.

As a teleconferencing system, FORUM has unique characteristics not typical of other computer systems. Of primary concern in its development have been the techniques of translating the perceived flow of a face-to-face discussion into the medium provided by the computer. The information flow in a synchronous conference is now well displayed by FORUM.

Other concepts implemented in FORUM are the handling of private and anonymous messages and the ability to access system services while in a conference. This treatment of conference activity, which facilitates social interaction, is unique to FORUM.

The ability of a participant to join an activity in an asynchronous manner has created an unforeseen demand on the system: the need to review past entries, add new comments or ideas, or suggest changes, for example, plays a more significant role than had been anticipated.

B. FUTURE DIRECTIONS

The long-range goal of the teleconferencing project at the Institute is the development of a group communications tool based on computer-science concepts. In the course of this initial effort, we have created a teleconferencing system that we have now been able to observe in over twelve months of actual operation. It is still very primitive in several respects: first, the implications of synchronous (simultaneous) conferencing remain largely unknown, both in terms of computer support of thought processes and in terms of user behavior; second, the possibility of multimedia (audio and video) adjuncts to the computer conferences has hardly been explored.

Much of our work to date has consisted in inventing data structures and access mechanisms suitable for the use of computers as a communication medium. We have encountered two major technical obstacles in this respect.

1. Ordinary computer architecture creates severe limitations for our conferencing needs. Teleconferencing will require a revision of the organization of various computer resources in order to make efficient communication among many users possible.
2. Ordinary concepts in file processing, that rely on separation of user files and access paths, do not apply in the conferencing environment. We have found that a *single* user, namely FORUM itself, had to have complete access control. This leads to an unusual situation in terms of privacy, protection, and accounting.

An extremely rich domain for further research has been identified in the course of this effort. The specific computer-science questions it addresses (leaving aside the entire field of social impact and psychological reaction to the medium) follow.

- How can conferencing be interfaced with other functions shown in Figure 6A, especially in the area of text editing and fact retrieval?
- How can a mechanism be provided for the identification of semantic threads and subgoals in a discussion?
- How can the knowledge of man/machine interaction be adapted, or extended, to a nonclassical situation of computer-mediated group communication (man/machine/man interaction)?
- How can a conferencing program be offered at a very high level of reliability over a network where actual processing of the conference activity becomes machine-independent?

When computer communication becomes more widespread, we foresee a number of new problem areas that deserve careful exploration. One of these areas involves the coupling of conferencing activities to other functions, such as document preparation and publication, that are equally vital to the management task. Another is the definition of retrieval functions capable of operating on what is basically an unstructured, unindexed data base. Yet another area deals with the adaptation of the computer to the needs of an office environment.

In considering the last point, it is useful to remember that management information systems have largely failed because their assimilation in the framework of an executive's activities present too high a threshold in terms of training, usage patterns, and restriction of information types. Reliability and privacy are at the top of the list of the requirements for a successful system, and these must be addressed immediately. It is unlikely, however, that certain constraints--for instance, the need to type on a keyboard--will be removed within the next ten years. Human factors aspects of software design have been generally neglected; under these conditions, we feel that considerable attention should be devoted to psychological and

social factors before any attempt is made to introduce teleconferencing into a large, operating environment.

Another aspect of teleconferencing that requires further examination on the basis of the trends we have already observed concerns the trade-off between travel and communication. Writing in the February 1974 issue of *Telecommunications*, Paul Polishuk has stated that:

"The Office of Telecommunications believes, based on analyses conducted to date, that as much as 5 percent of the total annual petroleum consumption in the United States can be saved by substituting telecommunications for the transport of people and goods."

While our own project intends to explore these substitution possibilities further, experience with the FORUM medium leads us to consider as equally exciting the opportunity to regard computer conferencing as a genuinely new way for groups to exchange ideas, to do planning, and to arrive at decisions. Especially relevant in this respect are the observations by Arthur Hastings that "FORUM conferencing at the Institute clearly resulted in staff members having a common ground for communicating" and that "the highest proportion of entries in any category (in the staff meeting) is from reports made while traveling." If a communication framework can be maintained, and even enhanced, while members of a research group or management team are physically separated by large distances (as in the situations we have observed), then a major change in work styles and intellectual patterns seems possible. Such a change may be even more significant in the long run than the energy savings which teleconferencing may provide in the near future.

APPENDIX 1: FORUM USER GUIDE

APPENDIX 1: FORUM USER GUIDE

A. JOINING A FORUM ACTIVITY

The ARPANET environment demands that a user connect his terminal to a host computer through the following actions.

1. Dial the TIP number; wait for high-pitched tone; and place phone in acoustic coupler. Both terminal and coupler should be set for FULL and 30 cps.
2. Type everything printed below in boxes, leaving spaces where they are shown and ending each line with one carriage return [CR].

```

[ ]
Hello...
[ @D C E [CR] ]
[ @L XX [CR] ]      where "XX" is the number of the host computer
ISI-TENEX...
[ @LOG [DIRECTORY NAME] [PASSWORD] [ACCOUNT] [CR] ]
JOB
[ C<DIRNAME>FORUM [CR] ]      where "DIRNAME" is the specific directory
```

This will start the FORUM program. You will be asked for your last name and information concerning terminal equipment you are using.

You will then get a list of the conferences available to you. If you choose none of these, the FORUM program will automatically return you to the TENEX executive. (Note that if you are using the CHAIRMAN program, you may opt not to join an existing conference, and will be given a "COMMAND?" prompt and the ability to set up a new conference.) If you are registered in only one conference, FORUM will start you in that conference automatically.

Having selected a conference, its title and information on its structure and participants will be printed. Since most of the activities in a conference are discussions, the following sections concern themselves with this type of activity. Other activities (e.g., eliciting a number or a probability estimate) are explained by FORUM and require no background other than that obtained by typing a question mark [?].

Making an Entry in a Discussion

While in a discussion you may make an entry at any time--simply start typing. To end an entry, strike the carriage return key [CR] twice. See instructions for editing entries on pages 74 and 75.

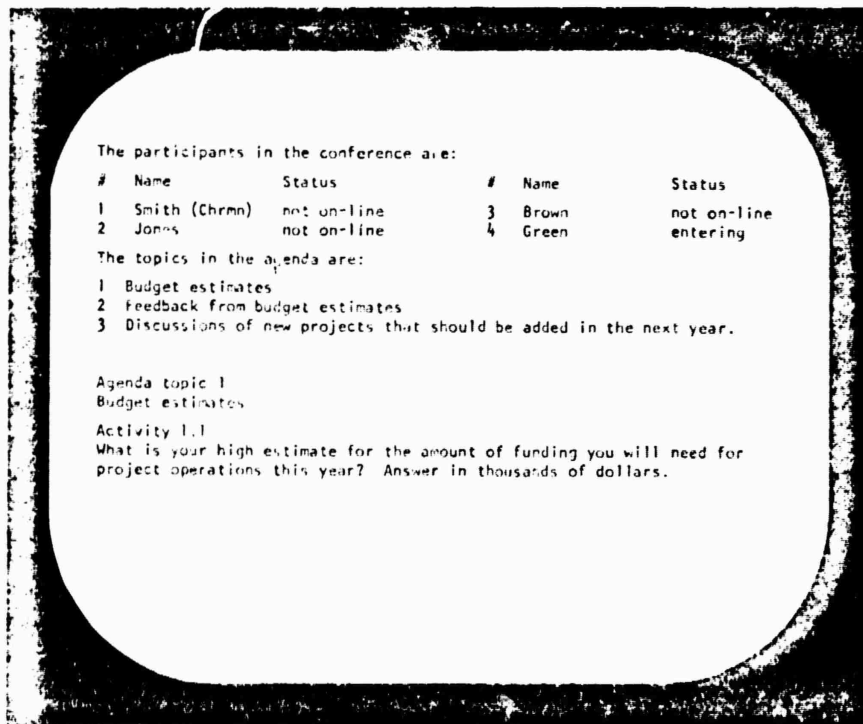
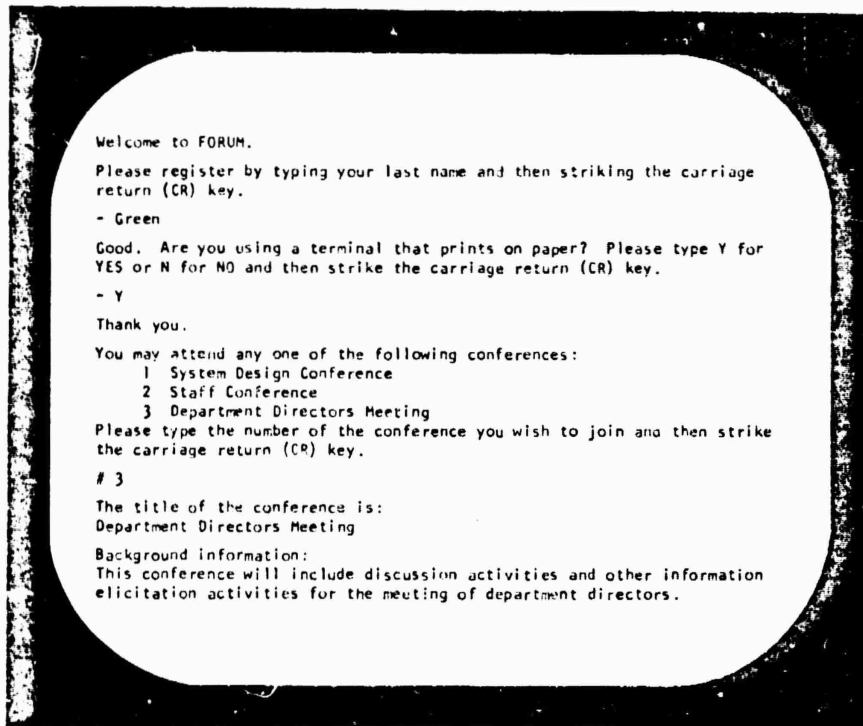

Figure 13. Entering a FORUM Conference

Making an Anonymous Entry in a Discussion

Begin your message by striking the exclamation point [!]. (Note that "!" must be the first character typed.) Type your message as you would for a standard entry, ending it with two carriage returns [CR].

Sending a Private Message

Begin your message by typing a left parenthesis [()] as the first character typed. FORUM will automatically print the word "to". You should then enter the name of the recipient of your message, followed by one carriage return [CR]. FORUM will prompt you for your message with a hyphen [-]. You may then begin typing the message. End your message with two carriage returns [CR]. For example:

```
[ (to SMITH) ] [CR]
- There will be a meeting at 3:15 pm on Tuesday. [CR]
- [CR]
```

Commands

Two means of accessing FORUM commands are available in release 5.

1. While participating in a discussion activity, you may send a private message to FORUM rather than a human participant. This allows you to access special FORUM services without leaving the discussion activity. Once the command action is taken by the program, you are returned to the ongoing discussion, having never really left the activity.
2. At any point in the program, you may go to the upper-level command mode (in which you have a full set of FORUM commands) by striking the ESCape or ALTmode key. This command mode removes you from any conference activity you are participating in and prints a prompt to your terminal as follows:

```
COMMAND?
*
```

After the command action is completed, you are either returned to the command mode (indicated by another "COMMAND?" prompt), or to an activity at which the command given will explicitly place you. For example:

```
COMMAND?
* [GO] (to activity) [2[CR]]
```

B. USER FUNCTIONS

Getting Help from FORUM

If you are not sure what action to take at any time during a FORUM conference, strike the question mark key [?] as your first letter of input.

To Leave FORUM

To end your participation in FORUM, simply hang up your telephone. If you want to remain on the network in non-FORUM-related work, send the following private message to FORUM itself:

```
[?]to FORUM [CR]
- QUIT [CR]
```

Or, if you are in the upper level command mode:

```
COMMAND?
* QUIT [CR]
```

You will then be placed into the TENEX executive.

Moving from One Activity to Another

To leave one discussion activity and go to another in the same conference, you may do either one of the following.

1. Send a private message to FORUM and use the special service requests "GO (to activity) N", "NEXT (activity)", or "PREVIOUS (activity)"
2. Strike the ESCape or ALTmode key and, after receiving a "COMMAND?" prompt, use the same commands listed above.

For example:

```
[?]to FORUM [CR]
- NEXT (activity) [CR]
```

or

```
[S] where ESCape or ALTmode key is typed
COMMAND?
* NEXT (activity) [CR]
```

Editing Entries

Strike the back arrow to erase the last character which you typed. If you strike the back arrow several times, the corresponding number of characters

will be erased. (Be sure to count blank spaces between words as characters when doing this.)

Strike the DEL or RUBOUT key twice to erase an entire entry. For users acquainted with TENEX conventions, the control character operations for program control and editing are accepted within FORUM.

Stopping Output

You may stop output to your terminal by striking the DEL or RUBOUT key twice. The FORUM program will stop printing the current block of text and continue with the next operation.

C. SPECIAL FORUM SERVICES

While in a discussion activity, you may gain access to certain special FORUM services by sending a private message to FORUM itself. To obtain a list of available services, send the following message:

```
[to FORUM] [CR]
- ?
```

For your convenience, each service is described below. End service request with one carriage return [CR].

1. DESCRIBE

Explains the use of the other services on the list. For example:

```
[to FORUM] [CR]
- DESCRIBE REVIEW[CR]
```

or

```
[to FORUM] [CR]
- DESCRIBE ALL[CR]
```

2. STATUS (of participants)

Provides you with a list of the people registered in the conference in which you are participating and the current status of each one.

3. SUBMIT (file)

Inserts the text file you specify as your next entry in the discussion. For example:

(to FORUM) [CR]
- SUBMIT (file) MYFILE.TXT [CR]
Your file has been submitted as entry [40]

where "MYFILE" is the name of a text file

4. REVIEW (entries)

Retrieves and displays the entries you specify. You may use any of the following options, alone or in combination:

- a. "BY" and a list of participant names (or the word "ALL"). For example:

(to FORUM) [CR]
- REVIEW (entries) BY SMITH [CR]

or

(to FORUM) [CR]
- REVIEW (entries) BY SMITH AND LEE [CR]

- b. "IN" and a list of entry numbers (or the word "ALL"). For example:

(to FORUM) [CR]
- REVIEW (entries) IN 2,5-9,14 [CR]

- c. "LAST N" entries (to see only the previous entry, simply type "LAST"). For example:

(to FORUM) [CR]
- REVIEW (entries) LAST 3 [CR]

- d. "BEFORE", "ON", or "AFTER" a date. For example:

(to FORUM) [CR]
- REVIEW (entries) BEFORE 17-APR-73 [CR]

or

(to FORUM) [CR]
- REVIEW (entries) ON 4/17/74 [CR]

- e. "RE" and a text string in quotation marks. For example:

(to FORUM) [CR]
- REVIEW (entries) RE "ENERGY" [CR]

The program will retrieve all entries in the current discussion activity containing that text string.

If you do not wish to review the complete heading and text of the entries you have specified, you may use any of the following restrictions, alone or in combination:

- a. "BY FIRST LINE" or "BY FIRST N LINES"
- b. "NO HEADING" ← this suppresses the printing of the author's name, date, and time stamp
- c. "NO TEXT"

For example:

```

[ (to FORUM) [CR]
- REVIEW (entries) BY SMITH BY FIRST 3 LINES [CR]

```

or

```

[ (to FORUM) [CR]
- REVIEW (entries) BY SMITH ON 4/17/73 NO HEADING [CR]

```

5. SAVE (entries)

Saves the entries you specify by placing them in the TENEX text file you name. To specify the entries, you may use any of the options listed above under *REVIEW (entries)*. For example:

```

[ (to FORUM) [CR]
- SAVE (entries) BY SMITH [CR]
in FILNM.TXT [CR] (New File) [CR]

```

↑ confirm that this is a new file by typing one carriage return [CR]

Note that FILNM is the name given to the file for this example.

To append entries to an existing text file, you must specify the file name and the version number of that existing file. For example:

```

[ (to FORUM) [CR]
- SAVE (entries) BY JONES [CR]
in FILNM.TXT;1 [CR] (Old Version) [CR]

```

↑ confirm that you are adding entries to the old version of the file by typing one carriage return [CR]

The program will take the file containing the entries made by Smith and append the entries made by Jones.

6. GO (to activity)

Puts you into the activity in the conference which you specify. For example:

```

[ (to FORUM) [CR]
- GO (to activity) 2 [CR]

```

7. NEXT (activity)

Puts you into the next activity on the agenda. For example, if you are in activity 2 and want to move to activity 3, type:

```
(to FORUM) [CR]
- NEXT (activity) [CR]
```

8. PREVIOUS (activity)

Returns you to the activity preceding your current one. For example, if you are in activity 2 and want to return to activity 1, type:

```
(to FORUM) [CR]
- PREVIOUS (activity) [CR]
```

9. JOIN (conference)

Allows you to move from one conference to another. If you would like a list of available conferences, follow the "JOIN (conference)" request with a question mark [?]. For example:

```
(to FORUM) [CR]
- JOIN (conference) 2 [CR]
```

or

```
(to FORUM) [CR]
- JOIN (conference) ?
```

An example of special service use while in a discussion is shown below:

```

• [67] HENRY (CHRMN)
  - If everyone has the exact proposal in front of him (entries
  - 42-49, I think), perhaps we should base our discussion there
  - for the sake of precision.[CR]
  - [CR]

• (to FORUM) [CR]
  - REVIEW (entries) 42-49 [CR]

• [42] HENRY (CHRMN) FRI 21-DEC-73 3:48 PM
  I am now finishing a short paper describing the next 6 months of re-
  search with FORUM. I'll be getting copies of this to all of you, and
  perhaps we can critique it in this conference. OK?

• [43] HENRY (CHRMN) MON 24-DEC-73 10:45 AM
  .
  .
  .

```

Activity 2.3

The group's aggregated forecast for the total budget in 1976 will be fed back in graph form as a probability density function over the range of forecast budgets.

Display of probability estimates from Activity 1.3

We would like you to forecast our budgetary needs for the year 1976 (in thousands of dollars), using a probabilistic approach to determine the range of forecast and the median value.

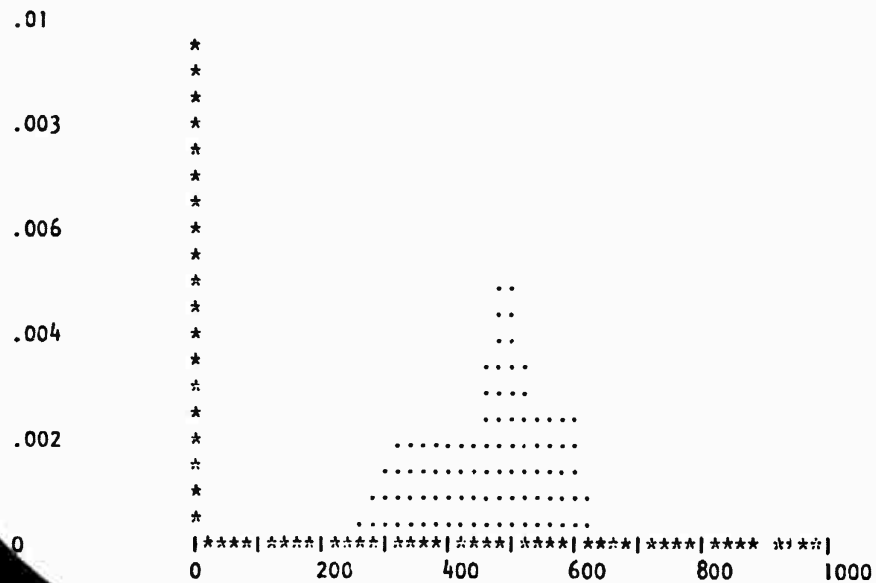

Figure 15. Display of Probability Estimates

FORUM's Upper Level Command Mode

To leave a discussion activity and reach FORUM's full command mode, strike the ESCape or ALTmode key. To obtain a list of available commands, strike the question mark key [?]. For your convenience, the commands are listed below. Several of these can also be reached as special FORUM services and are described there. Note that while special services allow you to input commands without leaving the discussion activity, the upper level command mode prompts you with:

COMMAND?

*

You do not have to send a private message to FORUM; rather, simply input the command, followed by one carriage return [CR].

1. DESCRIBE

See page 75.

2. CONFERENCE (information)

Provides you with any background information submitted by the chairman of the conference in which you are participating.

3. AGENDA (information)

Provides you with the complete agenda for the conference in which you are participating.

4. ACTIVITY (information)

Provides you with any background information on the conference activity in which you are participating.

5. STATUS (of participants)

See page 75.

6. CONTINUE

Returns you to the activity in which you were participating prior to entering command mode.

7. GO (to activity)

See page 77.

8. NEXT (activity)

See page 79.

9. PREVIOUS (activity)

See page 79.

10. PRINT (transcript for activities)

Provides a transcript of the activities you specify. For example:

COMMAND?
* PRINT (transcript for activities) 1,2,3 [CR]

11. SAVE (transcript for activities)

Saves the responses for the activities you specify by placing them in the TENEX file you name. For example:

COMMAND?
* SAVE (transcript for activities) ALL [CR]
in file MYFILE.TXT [CR] (New File) [CR] confirm that this is a
new file by typing one
carriage return [CR]

Note that MYFILE is the name given to the file for this example.

12. MESSAGE (to participants)

Lets you send a private message to anyone registered in the conference in which you are participating. After you have specified the name of the recipient, strike the carriage return key [CR] once. FORUM will prompt you to begin typing your message. To end the entry, strike the carriage return key [CR] twice. For example:

COMMAND?
* MESSAGE (to participants) SMITH AND LEE [CR]
- There will be a meeting at 4:00 pm today. [CR]
- [CR]

13. RESTART

Puts you at the beginning of the conference and lets you begin your activities again.

14. JOIN (conference)

See page 79.

15. QUIT

See page 74.

D. CHAIRMAN FUNCTIONS

Release 5 of FORUM has restrictions placed on the use of the CHAIRMAN program. The CHAIRMAN program is essentially the FORUM program with additional commands included in the upper level command mode. These additional commands are concerned with the creation, modification, and monitoring of conferences. The CHAIRMAN program will be modified significantly in release 6 of FORUM.

Entering Chairman

By issuing the following to the TENEX executive, you may run the CHAIRMAN program and have all the chairman capabilities in *all* conferences to which you have access, no matter whether you are the titular chairman or have set that conference up. During the log-in procedure, issue the command:

```
@<DIRECTORY NAME>CHAIRMAN[CR]
```

Creating a Conference

At any point after logging in and selecting a conference, you may go into the upper-level command mode by striking the ESCape or ALTmode key. Upon receiving the "COMMAND?" prompt, issue the "SETUP conference" command. For example:

```
COMMAND?  
* [SETUP] (conference) [CR]
```

This will call the SETUP program, a sequential process that *must not* be interrupted once it is begun. If errors are made during the process, they should be corrected after the conference is completed, using the modification commands described later.

1. Entering Names of Participants

The program will prompt you with:

```
Please enter the last names of the participants:  
Participant # 1 (CHRMN):
```

At this point, type the last name of the person who is to act as chairman, followed by one carriage return [CR]. You will then be prompted for the name of the second participant. You may continue to add names and will be prompted similarly each time. To indicate that no more participants are to be included, strike the carriage return key [CR] once when you are prompted for a name. For example:

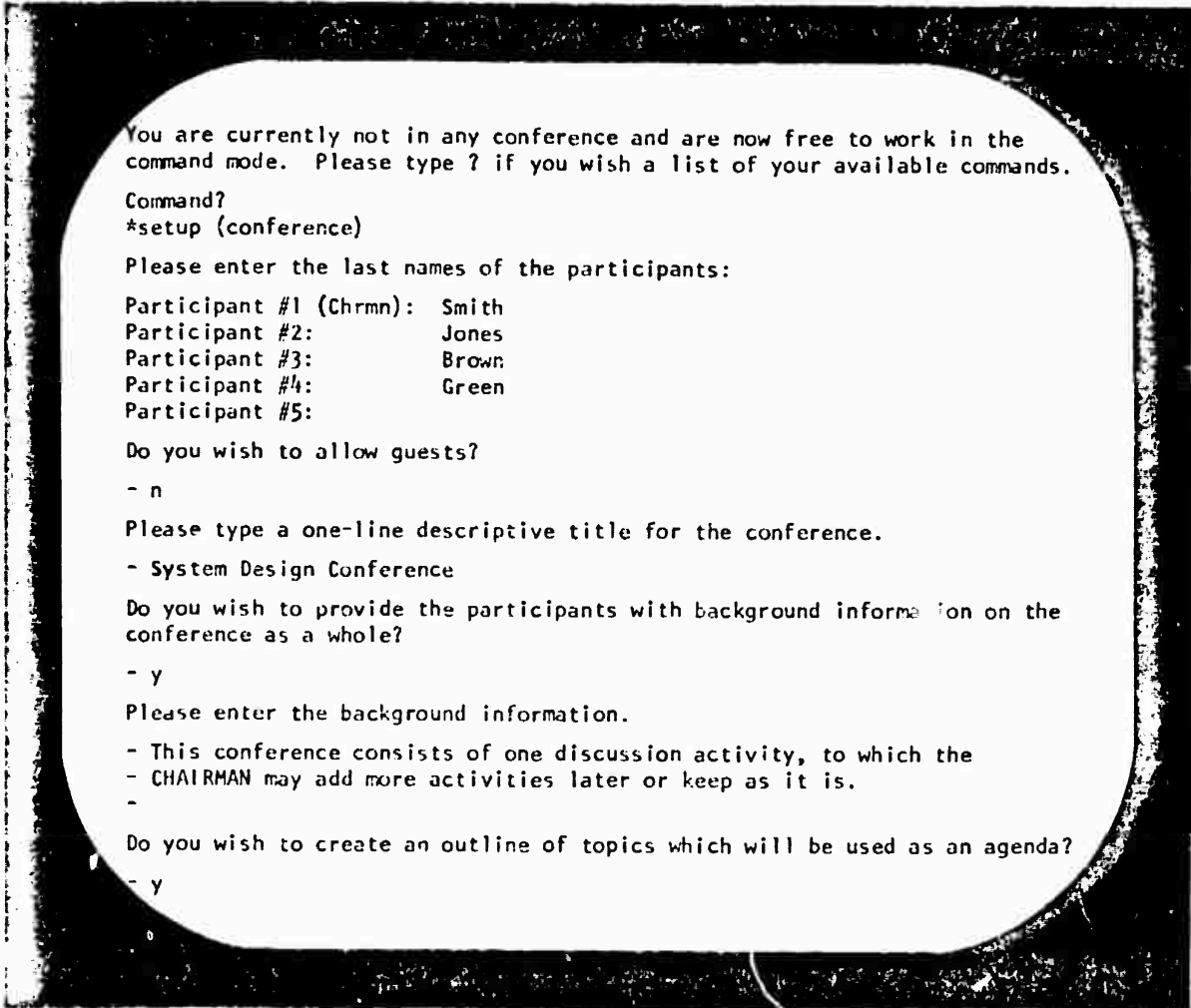

Figure 16. Setting Up a FORUM Conference

Please enter the last names of the participants:

Participant # 1 (CHRMN): Lee [CR]
 Participant # 2: Smith [CR]
 Participant # 3: Jones [CR]
 Participant # 4: Brown [CR]
 Participant # 5: [CR]

2. Privacy of Conference

You will then be prompted with:

Do you wish to allow guests?
 - N [CR]

By typing "N" (signifying "NO"), you have restricted conference attendance only to those participants you have explicitly named in step 1, or those inserted into the participant list using the "INSERT PARTICIPANT" command (see page 93). By typing "Y" (signifying "YES"), any user of the FORUM program may attend this conference and, if electing to do so, will be entered into the participant list by FORUM itself.

3. Title of the Conference

You will next be prompted with:

Please type a one-line descriptive title for the conference.
 - Demonstration of the CHAIRMAN program [CR]

This title may be longer than one line, but only the first line will be shown to participants when they are asked which conference they wish to attend. The title is ended by typing one carriage return [CR].

4. Background Information on Conference

You will then be prompted with:

Do you wish to provide the participants with background information on the conference as a whole:
 - Y [CR]

The "YES" response will then cause the program to ask:

Please enter the background information.
 - This is a conference set up solely for the purpose of demonstration. It should show the new chairman the means he has at his disposal by which he can create a conference. [CR]
 - [CR]

The background information for the conference will be printed out to the participant's terminal after the title is printed. This allows the chairman to offer prefatory remarks on the purpose of the conference, etc.

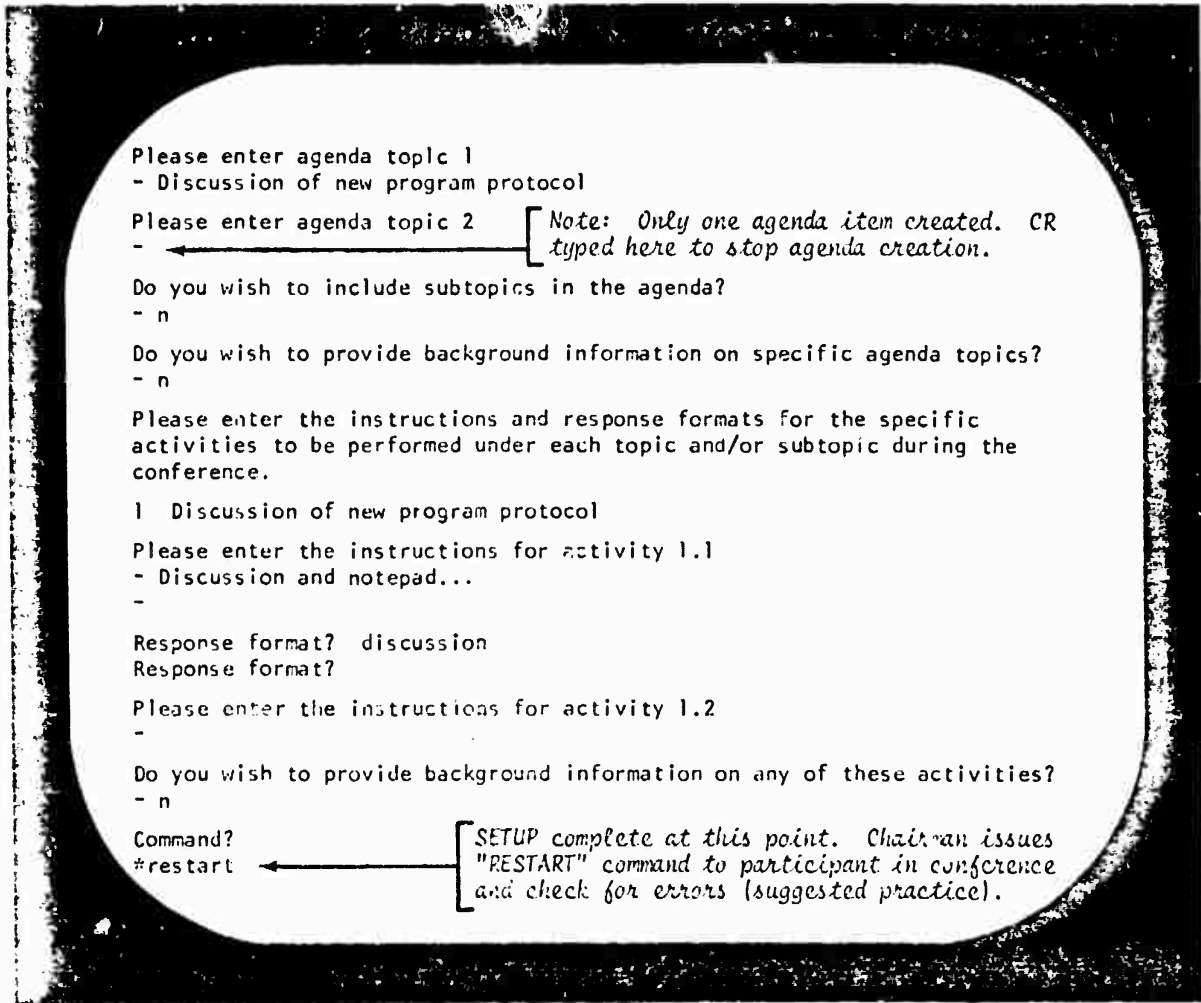

Figure 17. Setting Up a Conference Agenda

If you respond "NO" to the initial prompt, the program will go on to step 5.

5. Creation of the Conference Structure

a. Next, you will be prompted:

Do you wish to create an outline of topics which will be used as an agenda during the conference?

- Y[CR]

It is not mandatory that you create the outline structure. You can elect to create only activity items that will be structured sequentially and with integer item numbers. By specifying "YES", you provide the participant with a division of the conference which will be printed out when he enters the conference. If "NO" is specified, the program will go to step 6. In the example, the chairman has elected to create an outline.

Please enter one-line descriptions of the main agenda topics.

Please enter agenda topic 1

- Demonstration of the discussion activity[CR]

Please enter agenda topic 2

- Demonstration of other information elicitation activities[CR]

Please enter agenda topic 3

- [CR]

By typing one carriage return [CR], the chairman signifies that there are no more main divisions to be made. This structure can be modified later using the "INSERT ACTIVITY" command (see page 94).

b. At this point, the demonstration conference contains only two agenda items, or divisions, and no activities such as discussions or number elicitations. The agenda items can be considered only as "placeholders" or labeled dividers. You will then be prompted with:

Do you wish to include subtopics in the agenda?

- Y[CR]

This gives the chairman the opportunity to further subdivide the conference by dividing the main agenda items into subtopics. If "NO" is specified, the program goes to step 6.

Please enter the numbers of the agenda topics for which you wish to include subtopics. If you do not wish to include more subtopics strike off by the CR key.

1[CR]

Please enter one-line descriptions of the main agenda topics.

Please type a one-line descriptive title for the conference.

- Department Directors Meeting

Do you wish to provide the participants with background information on the conference as a whole?

- y

Please enter the background information.

- This conference will include discussion activities and other information.
- elicitation activities for a hypothetical meeting of department directors.

Do you wish to create an outline of topics which will be used as an agenda during the conference?

- y

Please enter one-line descriptions of the main agenda topics.

Please enter agenda topic 1

- Budget estimates

Please enter agenda topic 2

- Feedback from budget estimates

Please enter the instructions and response formats for the specific activities to be performed under each topic and/or subtopic during the conference.

1. Budget estimates

Please enter the instructions for activity 1.1

- What is your high estimate for the amount of funding you will need for project operations this year? Answer in thousands of dollars.

Response format? number

Response format?

Please enter the instructions for activity 1.2

- What is your low estimate for the amount of funding you will need this year? Answer in thousands of dollars.

Response format? number

Response format?

Please enter the instructions for activity 1.3

- We would like you to forecast our budgetary needs for 1976 (in thousands of dollars), using a probabilistic approach to determine the range of forecast and the median value.

Response format? probability

Please indicate the maximum value of the variable.

* 750 Lowest or minimum value is assumed to be zero.

Figure 18. Setting Up Activities within an Agenda

Please enter agenda topic 1.1:

- [CR]

Please enter agenda topic 1.2:

- [CR]

Please enter agenda topic 1.3:

- [CR]

Please enter the numbers of the agenda topics for which you wish to include subtopics. If you do not wish to include more subtopics, strike only the CR key.

[CR]

In the preceding example, the chairman has elected to subdivide agenda item 1 into two subtopics. (He specified that he did not want an item 1.3 by typing one carriage return [CR].) The program then prompted him to determine if any other agenda item was to be subdivided. At this point, the chairman could have subdivided agenda item 2 or either of the subtopics created above (i.e. item 1.1 or 1.2). Instead, the chairman elected to make no more subdivisions. Thus, the sample conference structure now consists of the following agenda items and activity items. (The following message will be printed on a participating participant's terminal.)

The topics in the agenda are:

- 1 Demonstration of the discussion activity
 - 1.1 The first discussion
 - 1.2 The second discussion
- 2 Demonstration of other information-elicitation activities

c. You will then be prompted:

Do you wish to provide background information on specific agenda topics?

- [CR]

If "YES" is specified, the program will ask for the agenda item number to which you wish to supply background information and then ask for the text. It will keep asking for agenda item numbers until you type one carriage return [CR], signifying no more background information is to be placed into agenda items.

5. Creation of Activity Items

At this point in the process, you will be prompted:

Please enter the instructions and response formats for the specific activities to be performed under each topic and/or subtopic during the conference.

- 1 Demonstration of the discussion activity
 - 1.1 The first discussion

Please enter the instructions for activity 1.1.1

- This is the first discussion of this conference. I have sub-
- divided the first main topic heading for demonstration pur-
- poses. [CR]
- [CR]

Response format? DISCUSSION [CR]

Response format? [CR]

Notice that the program prints the conference outline structure and then prompts for the instructions of the first activity, which is a subdivision of the lowest agenda item (in this case item 1.1). The "Response format?" prompt asks the chairman what sort of information will be elicited in this activity. The options are:

- 1) "DISCUSSION"
- 2) "ESSAY"
- 3) "NUMBER"
- 4) "PROBABILITY"
- 5) A feedback option, "SUMMARY (results from activity) [ACTIVITY ITEM #]"

To clarify the procedure and the various response formats, the rest of the "SETUP conference" process for the demonstration conference is shown below:

Please enter the instructions for activity 1.1.2

- [CR] (indicating no further activities under agenda item 1.1)

1.2 The second discussion

Please enter the instructions for activity 1.2.1

- This is the second discussion. By setting up a series of
- discussions, a chairman may divide the topics of conversation
- or provide separate meeting rooms for subgroups in the
- conference. [CR]
- [CR]

Response format? DISCUSSION [CR]

Response format? [CR]

Please enter the instructions for activity 1.2.2

- [CR]

2 Demonstration of other information elicitation activities

Please enter the instructions for activity 2.1

- This is an example of the numerical-information elicitation
- activity. I might ask, "What is the sum of 6 + 5?" [CR]
- [CR]

Response format? NUMBER[CR]
Response format? [CR]

Please enter the instructions for activity 2.2

- This is the "ESSAY" format. I might want a short answer which
- will NOT be distributed to the other participants in this
- discussion until I wish the program to display the answers.
- The question I might ask is, "Please write a short position
- paper giving your stance on the proposed school bond election." [CR]
- [CR]

Response format? ESSAY[CR]
Response format? [CR]

Please enter the instructions for activity 2.3

- This is a demonstration of the probability-elicitation format
- which goes through an iterative procedure to obtain estimates
- of some numerical value, but which are uncertain for the
- respondent. For example, I might ask, "Please estimate the
- distance between San Jose and San Francisco, California (in
- miles)." [CR]
- [CR]

Response format? PROBABILITY[CR]
Please indicate the maximum value of the variable.
200 [CR]
Response format? [CR]

Please enter the instructions for activity 2.4

- This will demonstrate the feedback mechanisms to which you have
- access. "SUMMARY results" of a discussion will print the full
- transcript. [CR]
- [CR]

Response format? SUMMARY (results from activity) 2.1[CR]
Response format? SUMMARY (results from activity) 2.2[CR]
Response format? SUMMARY (results from activity) 2.3[CR]
Response format? [CR]

Please enter the instructions for activity 2.5

- [CR] indicates that there are no more
- activity items under agenda item 2

The "SETUP conference" procedure will then ask for background information since there are no more agenda items under which to place activity items.

Do you wish to provide background information on any of these activities?
- N[CR]

COMMAND?
*

The process is now complete, and the chairman has been returned to the upper-level command mode.

E. CHAIRMAN UPPER-LEVEL COMMAND MODE

At any point in the CHAIRMAN program (except during the "SETUP conference" procedure), the user may reach the full command mode by striking the ESCape or ALTmode key. To obtain a list of available commands, strike the question mark key [?]. For your convenience, the commands to which the CHAIRMAN program has access are listed below. In addition to these commands, the CHAIRMAN program has access to all of the commands of the FORUM program. The upper level command mode prompts you with:

COMMAND?
*

You may then type the command, followed by one carriage return [CR].

- 1. CLOSE (discussion at activity) [ACTIVITY ITEM #]
(for participants) [PARTICIPANT NAMES or "ALL"]

Will prevent a participant who is not using the CHAIRMAN program from entering or reviewing an activity with the "DISCUSSION" format. For example, if the chairman gives the following command:

COMMAND?
* CLOSE (discussion at activity) 1.1.1 [CR]
(for participants) ALL [CR]

all participants except those using CHAIRMAN will receive the message:

Activity 1.1.1
This is the first discussion of this conference. I have subdivided the first main topic heading for demonstration purposes.

The discussion on this subject is now closed.

and will be transferred to the next item automatically.

- 2. OPEN (discussion at activity) [ACTIVITY ITEM #]
(for participants) [PARTICIPANT NAMES or "ALL"]

Will reactivate a discussion for those participants designated after the "CLOSE (discussion at activity)" command has been given. Note that when a discussion activity is created in the "SETUP conference" process, the default is that the discussion is open to all participants.

3. DELETE (activity) [ACTIVITY ITEM #]
(for participants) [PARTICIPANT NAMES or "ALL"]

Will delete the activity from all the designated agendas. The FORUM and CHAIRMAN programs will not know of the existence of the designated activity or agenda item.

4. UNDELETE (activity) [ACTIVITY ITEM #]
(for participants) [PARTICIPANT NAMES or "ALL"]

Will reinstate the item designated in the agendas of the participants named after the "UNDELETE (activity)" command is given.

5. FEEDBACK [SUBCOMMAND]

This will allow you to have the summary results of an activity printed to your terminal, if you type:

COMMAND?

* FEEDBACK PRINT (summary results from activity) [ACTIVITY ITEM #] [CR]

Or, it will allow you to have the summary results fed back to all participants in an existing activity, if you type:

COMMAND?

* FEEDBACK SUMMARY (results from activity) [ACTIVITY ITEM #] [CR]
(under/at activity) [ACTIVITY ITEM #] [CR]

This second option does the same thing as specifying:

Response format? SUMMARY (results from activity) [ACTIVITY ITEM #]

in the "SETUP conference" process.

6. SETUP (conference)

See the section entitled "Creation of the Conference Structure" on page 87.

7. INSERT [SUBCOMMAND]

The optional subcommands are listed below.

- a. INSERT BACKGROUND (for item) [ITEM #]

Will ask for the item number and then prompt for the background text.

- b. INSERT PARTICIPANT [CR]

Will give you the next free participant number and ask for his/her last name. For example:

COMMAND?

* INSERT PARTICIPANT [CR]

Participant # 5: [NAME] [CR]

If you wish to change the name of a participant already specified, type the participant name rather than a carriage return. For example, for the sample conference:

COMMAND?

* INSERT PARTICIPANT MILLER [CR]

will cause the program to prompt:

Participant # 1 (CHRMN): [NEW NAME] [CR]

c. INSERT AGENDA (topic) [AGENDA ITEM #]

Will allow you to add a new agenda item with the number specified and ask for the one-line descriptive title, or, if you specify an already existing agenda item, it will allow you to replace the text of the one-line title for that item.

d. INSERT ACTIVITY [ACTIVITY ITEM #]

Will allow you to add a new activity item, will prompt you for the text and the response format, or will allow you to replace an already existing activity with a new set of instructions and response format.

8. ASSIGN (activity schedules for participants) [PARTICIPANT NAMES or "ALL"]

When you insert a new agenda or activity item (i.e., add a new item number to the agenda), you have only altered a master agenda but not the agendas of individual participants. For new items to be added to the sequence of events of participants, you must assign new activity schedules for those to whom the changes made by insertion should apply.

APPENDIX 2: PROGRAM ORGANIZATION AND PERFORMANCE

APPENDIX 2: PROGRAM ORGANIZATION AND PERFORMANCE

A. GENERAL STRUCTURE

This section deals with the performance of the operational version (FORUM-5) and with the file structure of the advanced prototype (FORUM-6) of a medium of interpersonal communication, which may operate in real time or, by means of message storage, as a delayed message-distribution system. Like earlier versions, FORUM-6 functions as an information-elicitation device which administers online questionnaires, processes the answers, and, under the control of the activity organizer, feeds back the participants' answers. The third function of FORUM is that of a limited information storage and retrieval system. The data base may include conversations held using this medium, questionnaire data, or personal data bases such as bibliographies, note pads, and so forth. The overall organization of the system is shown in Figure 19. As can be seen, an *activity* has a *title* and *contents*, possibly broken into *parts* that may represent a complete tree structure. The smallest unit of information accessible to the user is an *entry*. An entry has a *number*, an *author name* (possibly "Anonymous"), a *date/time stamp*, and *text*.

In the advanced prototype version there are two participant roles, organizer and participant. The program structure is accordingly based on levels of access to an activity: the ORGANIZER program will have total control over participant roles and text. Participants run the USER program that can be placed in *corrector* mode by hitting the ESCape or ALTmode key.

Formally described, the FORUM USER program can be represented as a finite-state machine. Figure 20 is a simplified diagram of the ten states or modes into which the FORUM program can currently be placed. These are as follows:

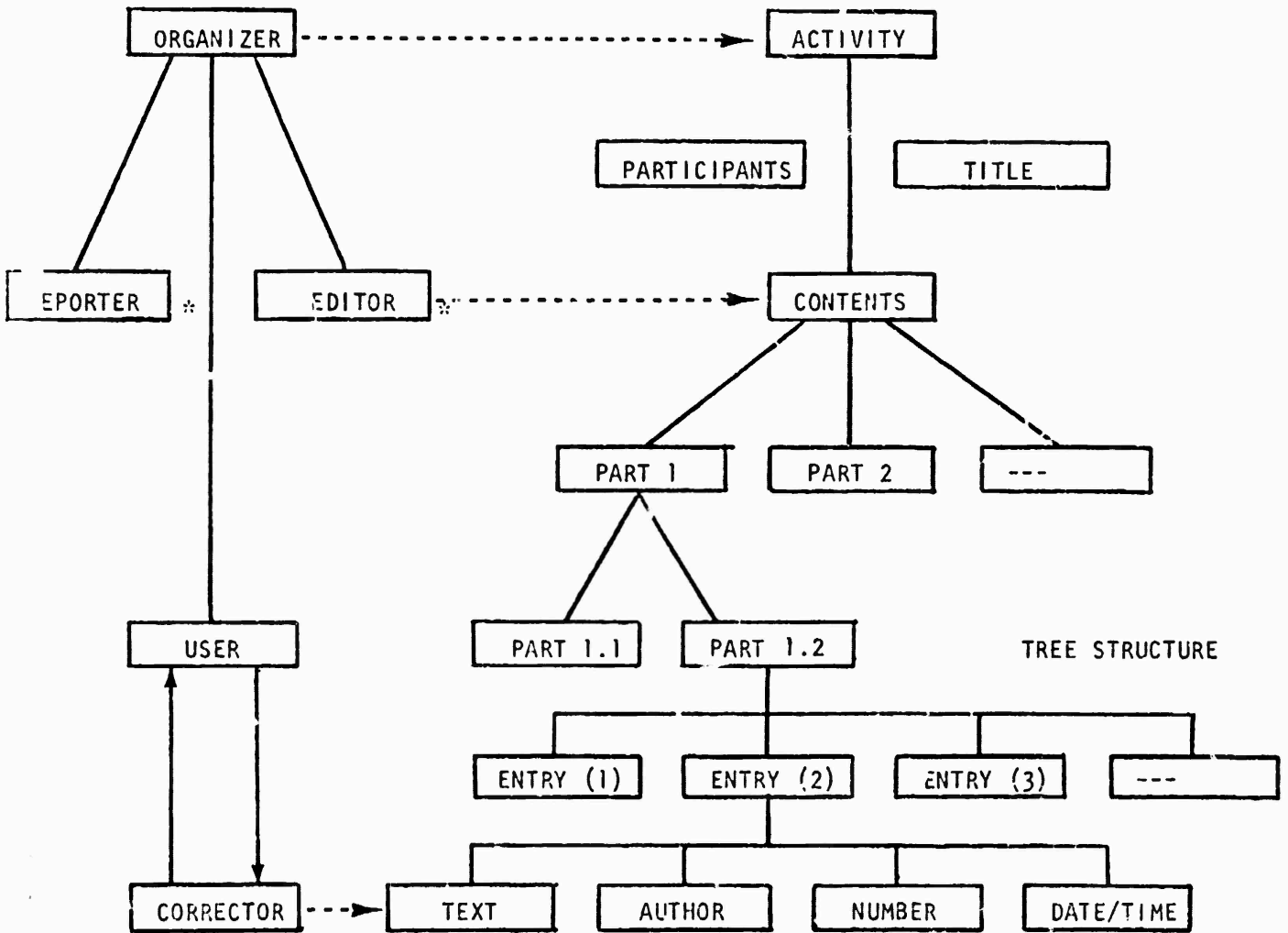

Figure 19. General Concepts for an Advanced Version of FORUM

* Not implemented in Release 6

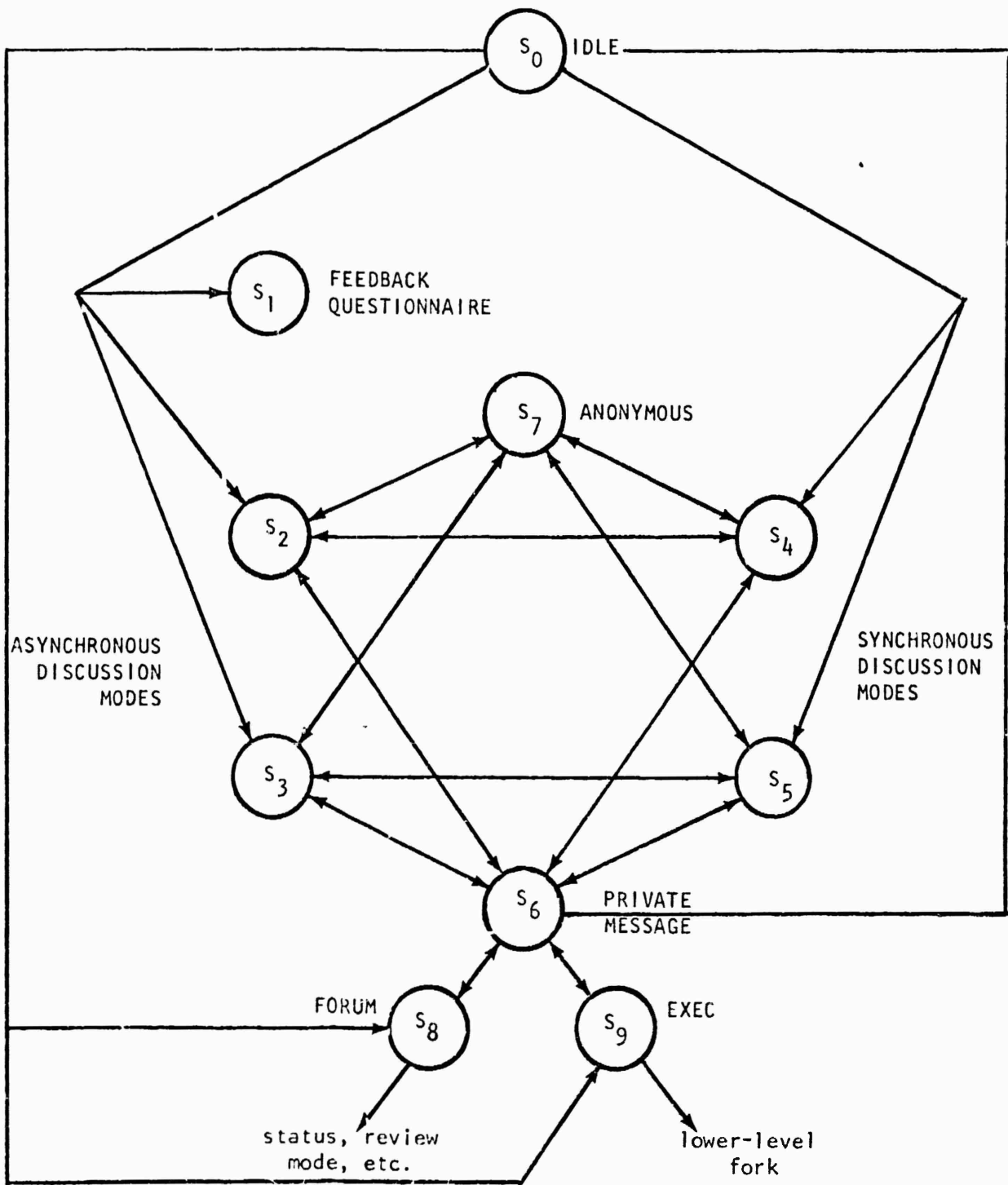

Figure 20. Simplified State Diagram

- s_0 = idle mode
- s_1 = feedback questionnaire (restricted format, single recipient)
- s_2 = asynchronous directed (one user, specific topic)
- s_3 = asynchronous free
- s_4 = synchronous directed (specific topic, simultaneous discussion)
- s_5 = synchronous free
- s_6 = private message mode
- s_7 = anonymous mode
- s_8 = "whisper" to FORUM
- s_9 = "whisper" to EXEC

In the idle mode, participants can review their own private-message file, send private messages to others, and display activity status. The feedback-questionnaire state corresponds to the administration by FORUM of a list of pre-specified questions. The asynchronous states are those in which the participant is the only user of a given conference by contrast with the synchronous states in which others are involved in real time. In the "whisper" modes communication is not with other human participants but with systems.

To illustrate this process, let us take the example of a user who is engaged in a free synchronous discussion mode (state s_5). Here any participant can send a message to any other with no topical restriction. Let us assume that he now types a left parenthesis as the first character of an entry and follows it with the full command:

(to FORUM) REVIEW ALL

The single parenthesis would be recognized as an input that triggers the transition to another state, in this case state s_6 (private message mode), where the recipient is a subgroup. The name of the recipient, however, is FORUM itself, which results in another transition, this time to the state s_8 , where the recipient is the system and where the format is that of a command that must follow the FORUM syntax.

We will see below how the same example will be processed by the various modules in the release 6 program.

Although this formal description of FORUM is highly simplified, it does convey one important point: in future as well as in current versions, the participant in a FORUM discussion has control over a wide range of operation modes, and the transitions between these modes involve the range of participation, the nature of the topics, the format, and other parameters.

The simplified state diagram of Figure 20 shows that the FORUM concept allows direct transitions between asynchronous and synchronous usage and never "locks" the user inside a particular mode, except in the special case of a questionnaire with feedback, where the user environment is purposely constrained.

The next two sections will describe how these functions are actually accomplished and what specific problems have been encountered.

B. PROGRAM MODULES

The various programs that correspond to the operation modes of FORUM are written entirely in assembly language and run under the TENEX timesharing system on PDP-10 computers. (Note: A version of FORUM-5 running under the TOPS-10 operating system is currently being implemented by the Institute for the Future.) There were several considerations that led to the choice of assembly language rather than a higher-level language (such as FORTRAN or PL-1). First, the available higher-level languages have been written for specific purposes that do not include remote conferencing. Thus, if we had chosen a higher-level language, we could have obtained a working program faster, but in the long run, we might have been constrained by the language itself and been severely limited in our efforts to implement the basic components of this teleconferencing medium at the level of detail that we required. The ability to control both input from the user and output to him was a basic need: features such as editing capability and paging for CRT terminals require a detailed control of the input/output monitor calls. The most important consideration in selecting an implementation language was that teleconferencing by computer involves communication

between parallel running jobs. The only practical way to achieve this is through shared files. Since the conventional file machinery of most systems is geared to the one user/one file concept, we were forced to bypass the available high-level mechanisms and build our own file-access system using the primitive monitor calls. At this writing, FORUM is the only conferencing system in existence that uses files that are shared in real time. This file-access system is explained further in Section C.

Assembly language also allows more efficient use of computer resources than do most higher-level languages. FORUM is completely reentrant so that not only participants in the same activity but also those in other activities use the same copy of the program. Moreover, FORUM is almost entirely input/output-oriented, or "I/O-bound". The implementation of the FORUM program in assembly language has allowed an efficient connect time to CPU time ratio, providing a low usage-demand on the host computer while giving good user/computer response times under heavy machine loads. As will be seen in Section D, where the results of an analysis effort are reported, FORUM typically uses *one minute* of PDP-10 computer time for every *two hours* of conferencing (per participant). Similar performance figures are expected under FORUM-6.

The FORUM-6 program is designed to run on a standard time-sharing system as a user program or eventually as a subsystem of the operating system itself. It consists of approximately 140 separate assembly-language subroutines which make up its executive program, five subsystems, and three utility libraries. The subroutines communicate with one another by means of the PDP-10's twenty accumulators, the shared files described later, a hardware-implemented pushdown stack indexed by accumulator 17 (reserved for this purpose), and the private memory space allocated to the job running the FORUM program. Certain locations in the memory space are given labels recognized by more than one subroutine so that these locations can also be used for passing arguments.

FORUM's executive subroutine (box #1 in Figure 22) is the first to begin execution when a participant enters. Its main purpose is to direct the participant to the activity he wishes to join, as well as to initialize the paging control, terminal control features, pseudo-interrupt system, and the

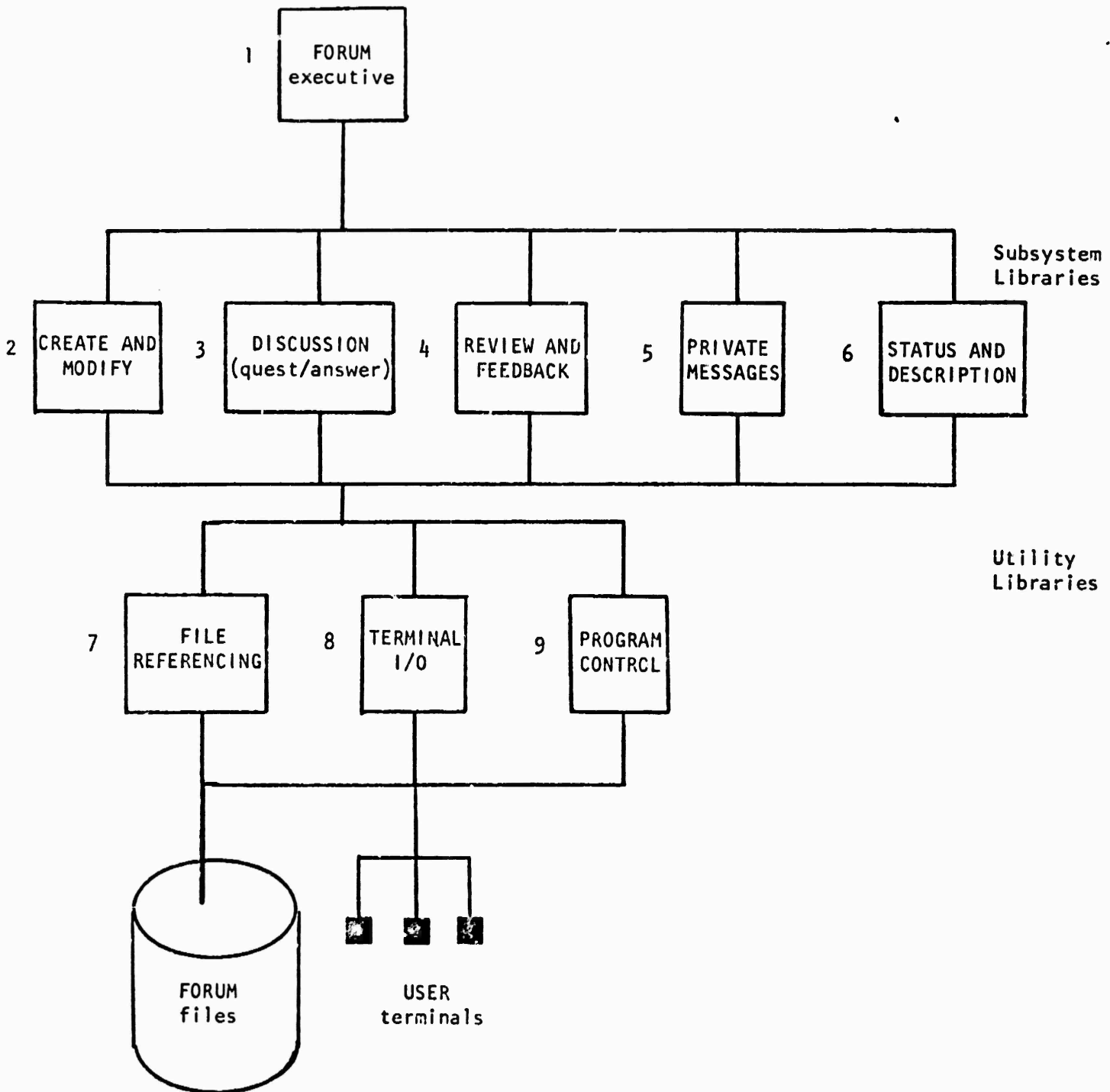

Figure 21. Overall Organization of the FORUM-6 Program

file system. Once the participant has decided which activity he wishes to join, FORUM transfers control to the appropriate subroutines.

This module handles the request for user name and password, the user recognition, and the terminal being used; it prompts the participant for the number of the activity he wishes to join. The same module also handles the leaving procedure and asks the participant whether or not he wants to join a different activity.

There are five *subsystem libraries* in FORUM. These elicit, process, and transfer information among the participants. The *utilities libraries* provide the functions that are necessary for the five subsystems to communicate with the participants. These are the boxes numbered 7, 8, and 9 in Figure 21.

When the participant has been recognized by Module #1, control is transferred into one of the five subsystem libraries based on information in the control file created by the organizer. Generally this will be to module #3 (discussion) where the interactive routine is stored. PROGRAM CONTROL (#9) contains most of the command routines. Some specialized commands, however, reside in CREATE AND MODIFY and others that deal with private messages are processed in module #5, but the main command reader is in module #9 which sends the user back to whatever program is required.

Module #1 is used for getting the name and password and joining or leaving conferences. When a user leaves one conference to join another, he is actually sent back to this module, as if he started again. That module contains the routines for resetting the status when a user comes into a discussion. This library also contains most of the subroutines that perform routine checking operations.

Module #2, CREATE AND MODIFY, is concerned with the main organizer actions. Its main command is the "CREATE/activity" command which guides the organizer and translates his instructions into a schedule of computer instructions that the participant programs will follow. The subsystem also provides commands to modify an existing activity once it has been created.

Module #3, DISCUSSION, handles the elicitation process given a pre-specified information format (e.g., number, probability, essay, or vote). It provides the storage function appropriate to each data type. This subsystem for processing information also contains the subroutines used for processing and printing

text entries either by command from a participant or under program control. There are four basic types of processing: textual, votes, single numerical estimates, and probability estimates. The type of processing is chosen automatically by the nature of the information being processed.

Module #4, REVIEW AND FEEDBACK, provides the processing of the files in response to user commands that require the reorganization and display of previously stored data.

Module #5, PRIVATE MESSAGES, handles all the nonpublic communication functions.

Module #6, STATUS AND DESCRIPTION, processes the request for status of participants when called by module #9. If a new user comes into a discussion, this information is reflected in the file and is processed and reported by module #3. There are actually three places where a person's status is reflected: (1) in the global file that keeps track of whether a person is online and what activity he's in; (2) the control file indicates which part the user is executing; and finally (3) the part information indicates who is typing.

Module #7 is the FILE-REFERENCING utility. It contains subroutines for storing and retrieving data from the set of three shared files used for each activity. These subroutines ensure that participants can both simultaneously and instantaneously read and write entries in these files.

Module #8 performs the pagination operation that is required on output. All of the terminal input/output operations are handled by this utility library. It includes subroutines for editing text, printing, and performing special functions for CRT terminals.

Every routine references module #7, so there is horizontal as well as vertical communication in the diagram of Figure 21.

The following example might illustrate the actual flow of control in release 6. Assume that a user is in a discussion activity. This input is being processed by module #3 until he types a left parenthesis. Let us consider the case when he types the command:

(to FORUM) REVIEW ALL

At that point, control is transferred to module #5, since the left parenthesis as the first character of an entry indicates a private message.

Module #5 will acquire the name of the intended recipient. In this case, it recognizes the name FORUM and relinquishes control to module #9, which reads the command "REVIEW". This triggers module #4 (REVIEW AND FEED-BACK), and after completion of the request, control returns to the discussion mode.

C. DATA STRUCTURES

FORUM maintains a participant-oriented global file and two random-access, mass-storage files, one which constitutes the data base for each activity and another which contains an individual participant's private message. The names of these two files are generated by FORUM. All control is done internally by the program, and the user is not aware of their existence nor the operations involved in "page mapping", etc. The two nonglobal files are:

- an *activity* file, in which all entries and interactions for that particular activity are stored; which contains a master copy of all the items that make up the activity; and which contains pertinent information on each user in that activity (e.g., name, history of use, skill ratings, and an individualized skeleton of the conference items)
- a *private message* file, in which copies of all private messages sent and received by the participant are stored

The files are all dynamically expandable; thus FORUM uses the space in these files only as it is necessary. Furthermore, since the files in the TENEX/PDP-10 environment are paged, the FORUM program, when loaded and running in core, does not need to map in the entire file, but rather only those pages of the file that are required. (An explanation of this is given in Section D).

When two or more users in a timesharing environment independently desire to change the contents of a common file, some means must be used to insure that their attempted changes do not interfere with one another. This protection against interference in other environments has generally been accomplished by giving the first user wishing to make changes exclusive access to the file. In designing FORUM, our desire was to eliminate this restrictive, or "locking-out", type of access. A data-file system which bypasses

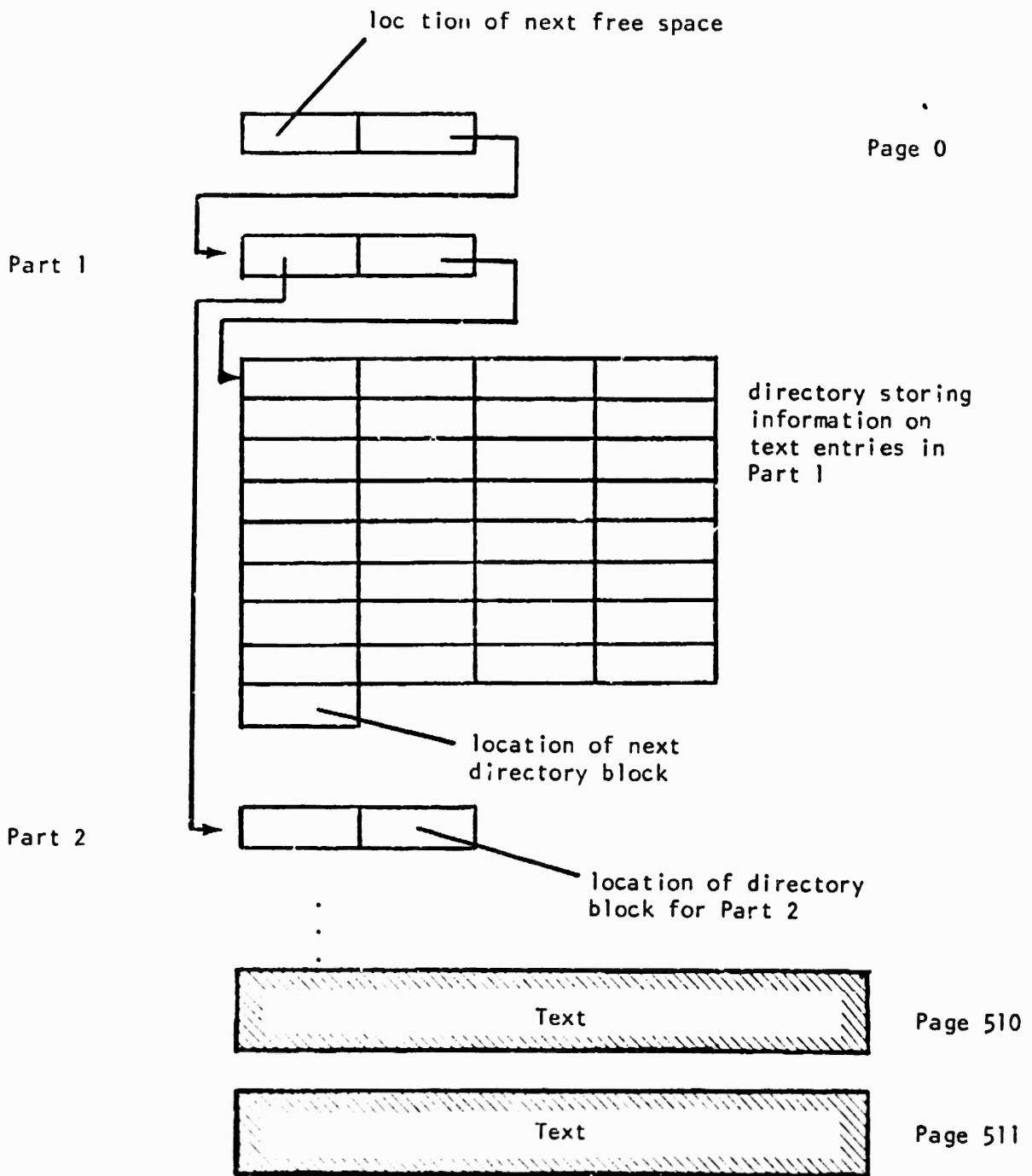

Figure 22. File Structure

the conventional file protocol was developed to allow simultaneous input and retrieval of entries into the data base by as many users as can use the computer.

The data-file system involves accessing a file in discrete pages and mapping each page into the user's memory space as the need arises. Because of the TENEX file-sharing capability, each user can then read from the file by reading his own memory space. To ensure that users writing simultaneously into the file cannot print over each other's entries, the first word of each file is used as a pointer to the location of the next free space in the file. Thus, to write into the file, a person's entry is first buffered in his own memory space until it is complete. Then the space for the entry is reserved by adding the length of the entry to the free-space word in one machine instruction. Finally, the entry is written into the reserved space without fear of someone else writing in it also.

To permit easy and efficient access to the information stored in the file, all entries are indexed in a set of directories. The overall structure uses linked-tree addressing to mirror the activity-part structure, while the directories for each part of the activity are linked directory blocks, each of which stores relevant information on sixteen text entries. To increase efficiency further, these directories are written together at the beginning of the file, while the text entries are written together starting at the end of the file and working backwards. This file structure is illustrated in Figure 22.

The *global participant file* (see Figures 23 and 24) contains information on all participants who are known to FORUM. This information consists of the first and last names, password, activity the person may join, the skill ratings, the last time in FORUM, as well as the current activity number, the number of times the person has entered FORUM, the directory from which entry took place, etc. A hash table is used to lead to a directory for fast identification according to a mechanism, the details of which follow.

Given a person's global participant number, a linear search down the data blocks will yield the corresponding entry. Given the hash value for

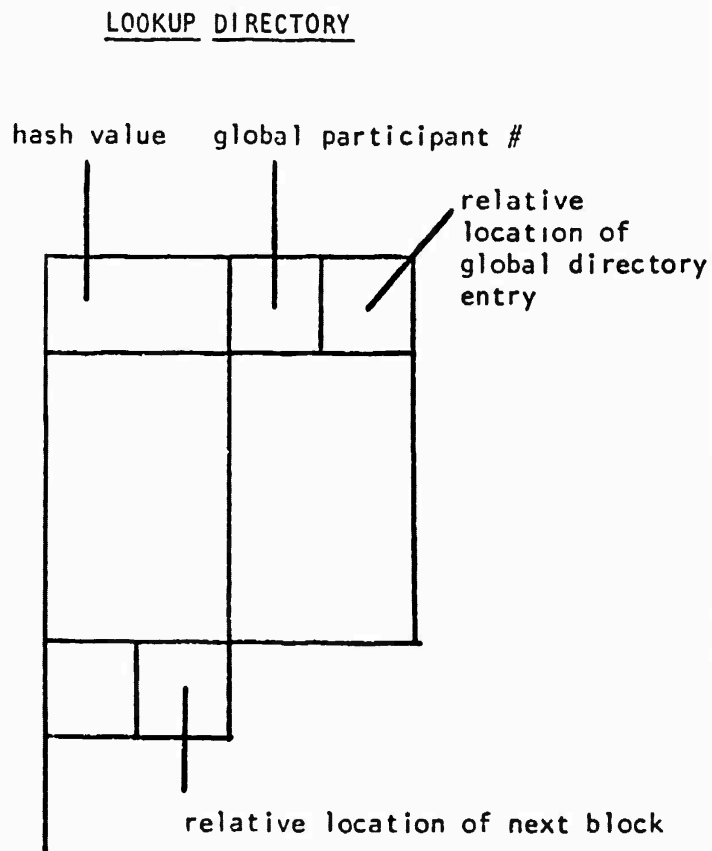
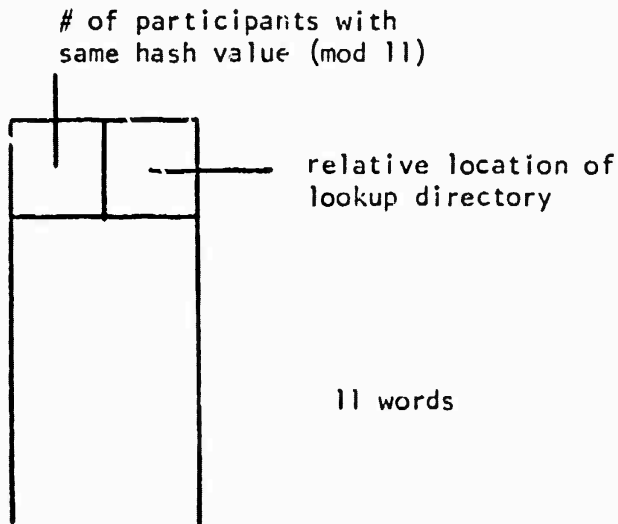
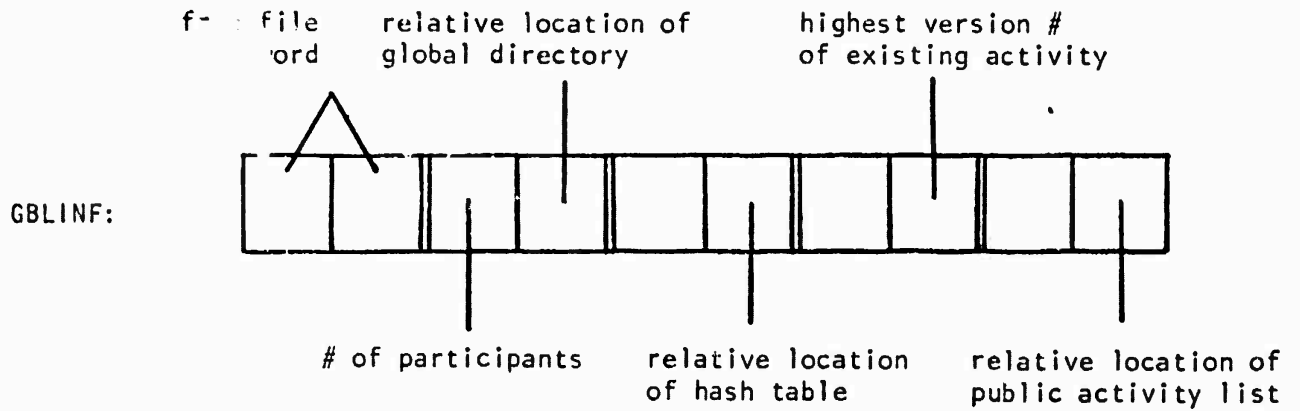

Figure 23. Participant's File

GBLLOC:

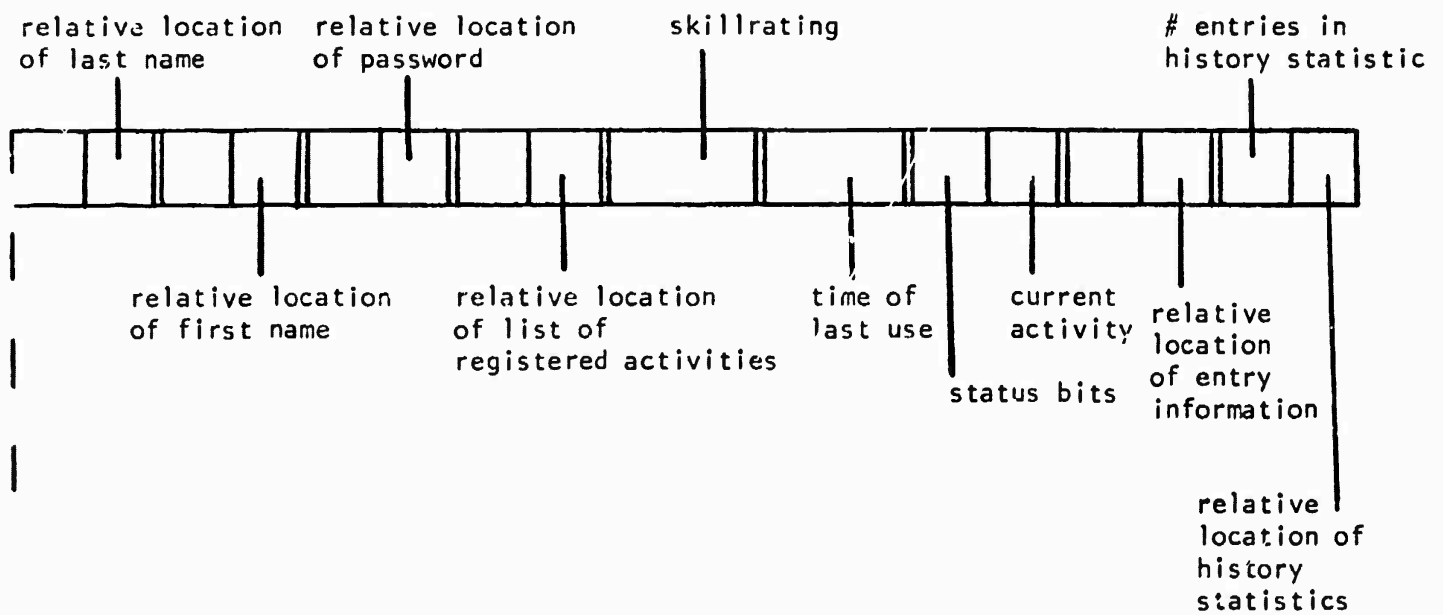

Figure 24. Global Directory

the name, this value module 11 gives the location in the hash table leading to the lookup directory. This directory, in turn, holds the relative location of the entry.

The *private message file* is a two-part structure and is also global for a particular user. (See Figure 25.) It contains a set of message directories with information about messages sent and received, and also a set of directories containing viewing summaries (how many messages the user has actually seen). This file enables a user to review and delete private messages that were sent as well as those received. The file is deleted at the end of a session if there are no messages in it (i.e., if all have been deleted).

The *activity file* shown in Figures 26 through 27 contains information on the structure of the activity, the participants and their status relative to the activity, and the text of the entries in the activity. This information is organized into three parts, each with a directory. The contents directory shown in Figure 26 points to the information the organizer entered when the file was first created. This includes the text of the parts and the tree-structure description. It is useful to recall that each part is a discussion by default. Elicitation of special information is stored as a special kind of text entry.

To each part corresponds a set of thirty-eight information words containing the joining and leaving bits, typing bits, and the numbers of up to thirty-six participants who can be active synchronously in the same part.

The text entry directory of the activity file is shown in Figure 27. The FORUM input buffer is two pages in length (or about 5,000 characters), but there is no limit to the length of a file that is submitted into an activity.

Several subdirectories correspond to each part. The *main directory* indicates who originated the entry, at what time, the number of lines, and the location of the actual text in the file. The *synchronous directory* is written when the entry is completed, and the *review directory* is allocated when the entry is begun. This mechanism is required to support the transition from the asynchronous to the synchronous interaction in a way that remains invisible to the user.

Message Directory

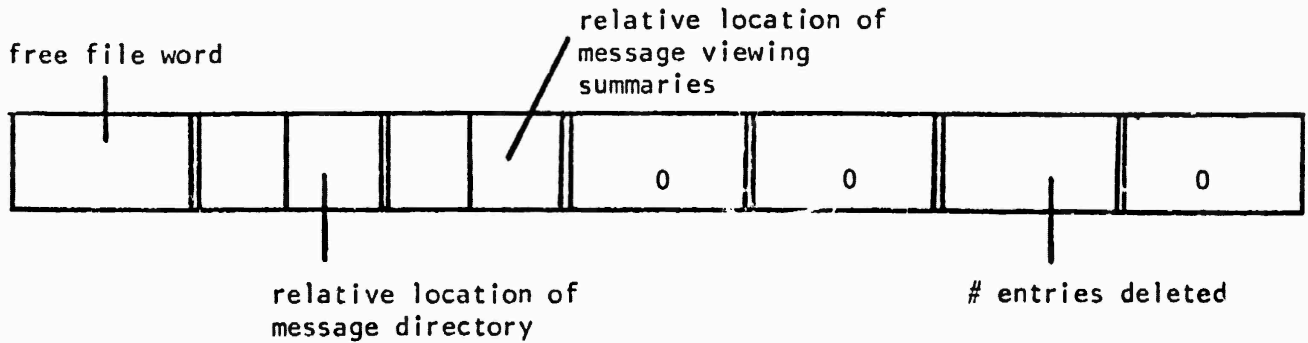

Message Entry Directory

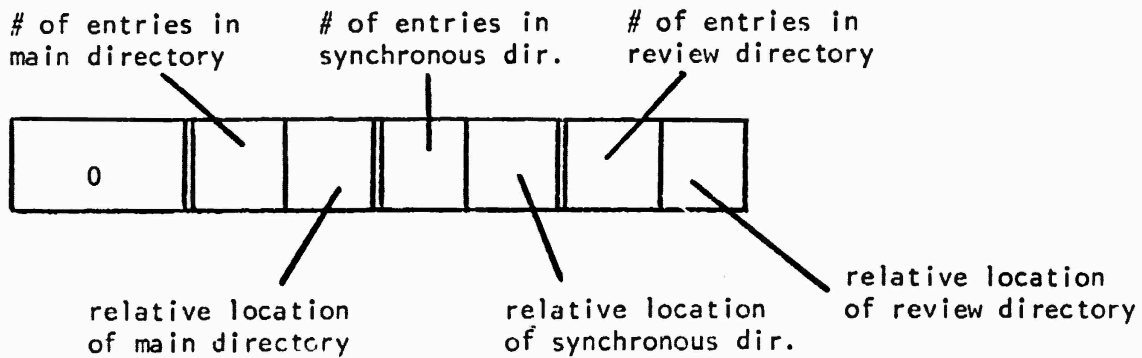

Message Viewing Summaries

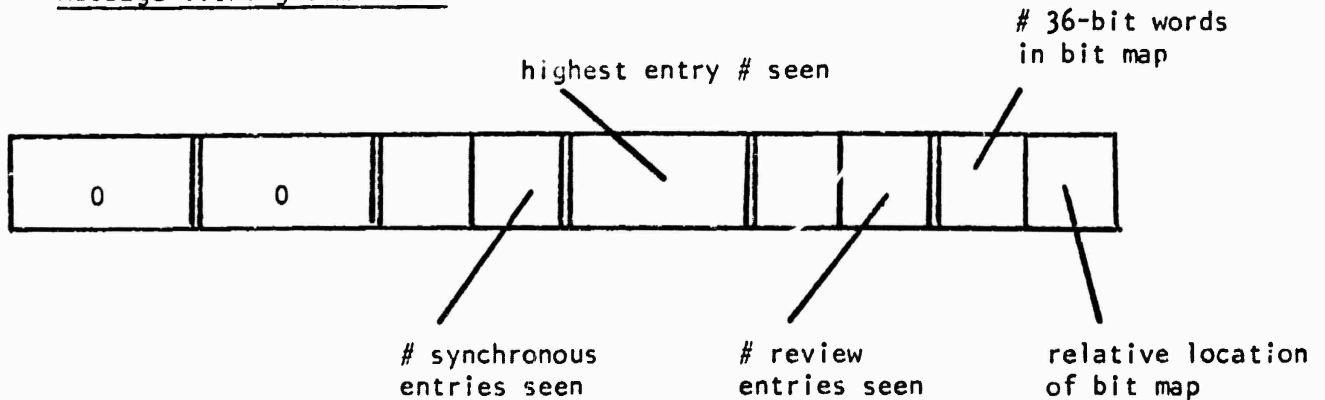
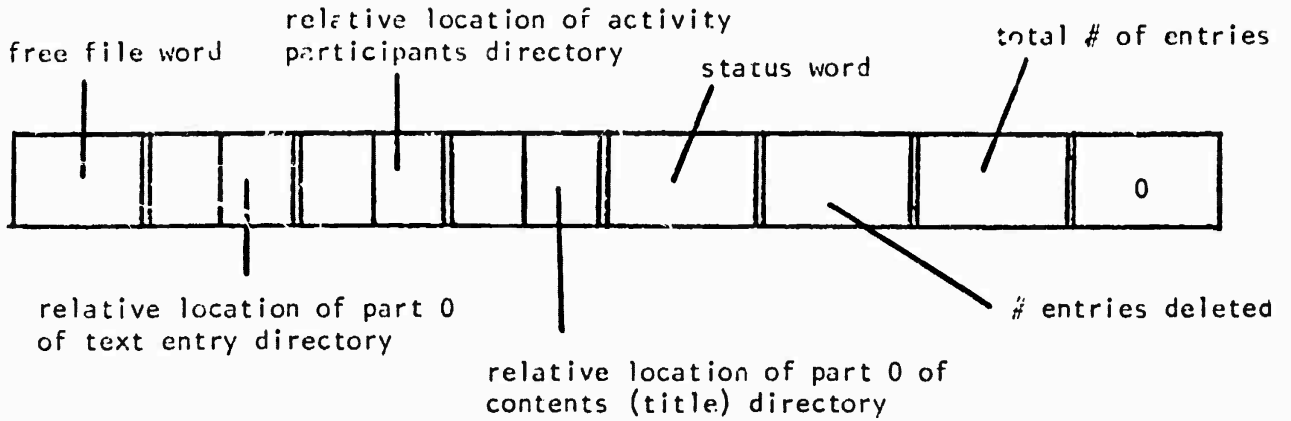
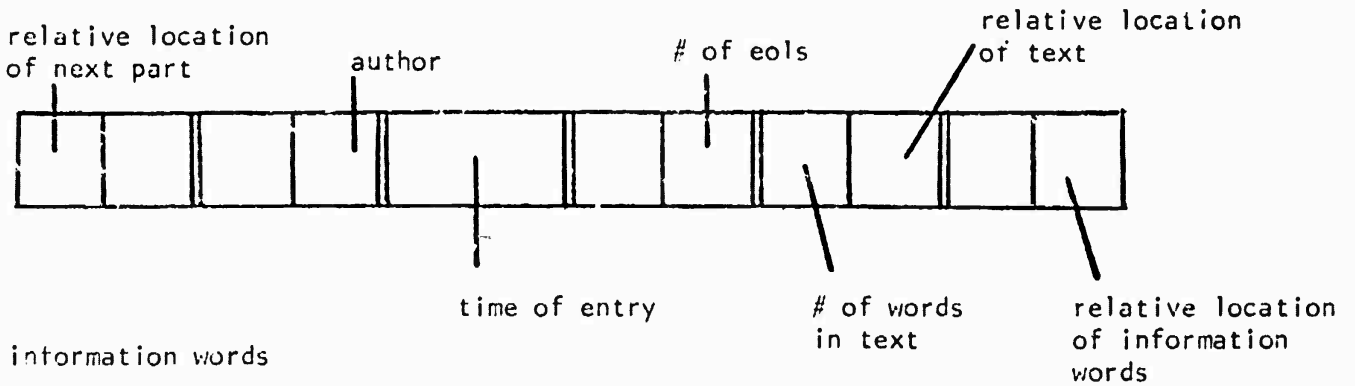

Figure 25. Private Message File

ACTINF:



Contents (Title) Directory



information words

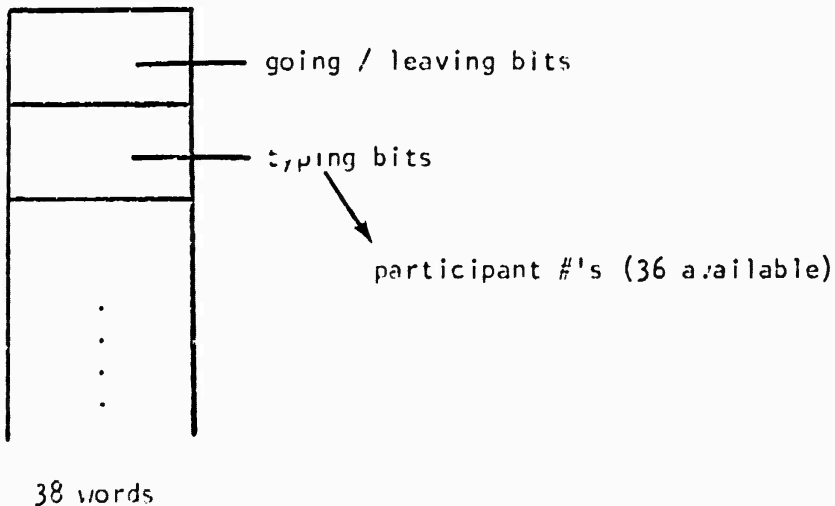

Figure 26. Activity File

DRTLLOC:

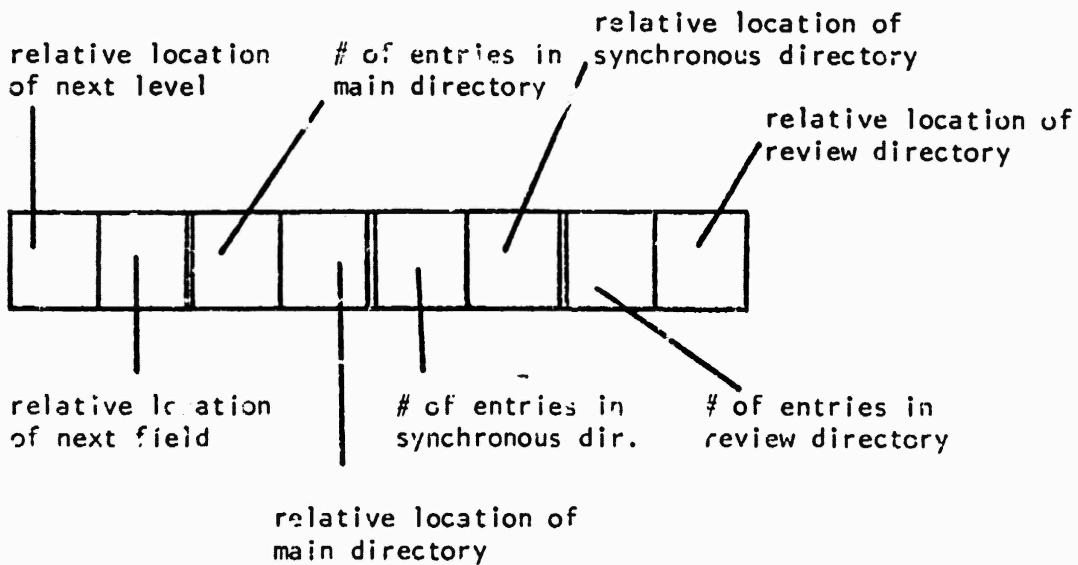
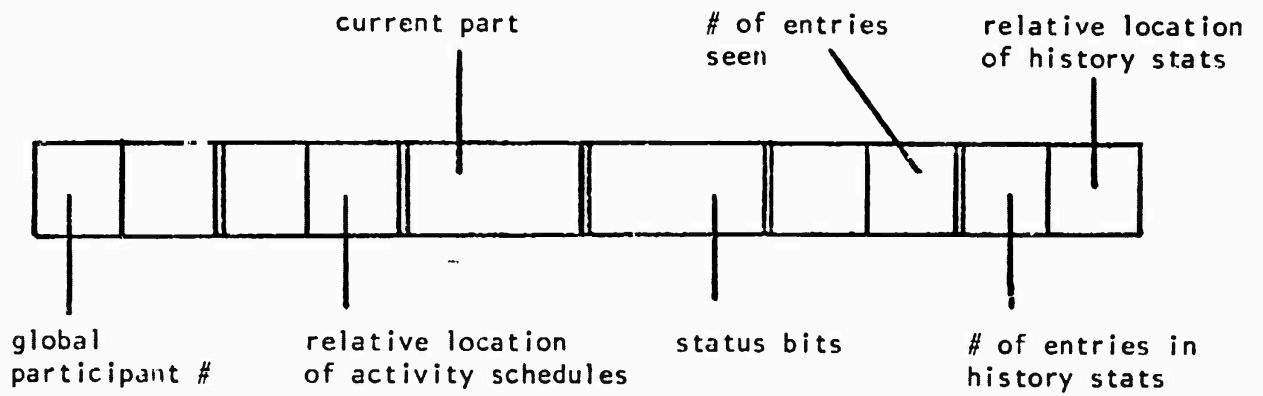

Figure 27. Activity File (Text Entry Directory)

RSPLOC:



Status bits if set

- bit 0----present
- bit 18----organizer
- bit 20----participant

Figure 28. Activity File (Activity Participants Directory)

The activity participants directory for each activity is indexed by the participant's local activity number and contains each user's global participant number, the relative location of the activity schedule, the current participant number, the status bits, the total number of entries the user has seen, and some entry statistics. The activity-schedule information is designed as a tree structure that mirrors that of the activity and holds the corresponding statistics. (See Figure 28.)

D. ANALYSIS

This section concerns itself with the actual operational performance of FORUM-5 as a running program on the PDP-10 computer at USC-ISI. These statistics, based on release 5 of the program, can be taken in most cases as an upper bound both in core size and running time with respect to future releases.

In the TENEX PDP-10 environment, the computer and disk space are divided into pages of 512 words of thirty-six bits each. This paging feature allows a more efficient use of computer resources since sections of the computer program need only be brought into core as needed. In a nonpaged environment, the entire program has to reside in core.

Release 5 is fifty-one pages in length and is reentrant. These fifty-one pages are divided into four pages of private memory space, six pages of shared files, and the remaining forty-one pages of pure computer instructions. By making the program reentrant in this way, it is possible (under the TENEX operating environment) for users to share most of the program. Thus, the first person to use FORUM would need to have the entire fifty-one pages of the program. However, the next and following users would only need an additional four pages of private memory space each, as they will share the files and computer instructions.

An important statistic for an interactive program concerns the ratio of CPU usage to connect time. In the case of FORUM-5, this ratio is very low. In other words, the program can run for many hours while using very little computer time. Typical runs of FORUM-5 yield the figure of one minute of computer time for two hours of conferencing (the corresponding cost, assuming standard industry rates, would be \$16 for such a conference).

We have obtained specific statistics for two users and have averaged them over many sessions. User 1 was running release 5 at 30 characters per second through the network. His CPU/connect time ratio, averaged over eleven sessions, is 1/140. User 2 was running release 5 at 240 characters per second on a terminal that was wired directly to the ISI machine. His CPU/connect time ratio, averaged over twelve sessions, is 1/170.

Another interesting statistic concerns the size of the files generated by FORUM. We have seen in Figure 11 the growth curves for two Institute conferences. The corresponding storage utilization is the following: At the time when the statistics were computed, there were 441 entries in Conference #1, broken down into 337 public entries and 104 private messages. The file size was sixty-two pages, of which the actual text occupied fifty-seven pages. There were 520 entries in Conference #2, with 431 public entries and 89 private messages. The file size was fifty-two pages, with forty-six pages of actual text. These figures are reflected in Figure 29.

We have also performed an analysis of the retrieval effectiveness of release 5 in REVIEW operations. The results are shown in Figures 30 and 31.

These statistics show a fairly constant value of 9 milliseconds per entry in Conference #1 for those retrieval requests that did not require text search. For the requests that did require text search (namely, requests such as REVIEW ENTRIES RE "EXPERIMENTS"), the search time is a function of the size of the entries and the number of characters in the string to be matched.

Conference Number	Entries			Text File				
	Total Entries	Public Entries	Private Messages	Size in Words	Size in Pages	Average Entry Length (char.)	Average Entry Length (words)	Entries/Page
1	441	337	104	28979	62	328	66	5.5
2	520	431	89	23475	52	225	45	10.0

Figure 29. Storage Statistics for Two FORUM Conferences

Review Criterion	Number of Entries (N)	Entries Retrieved (R)	CPU Time Seconds (T)	Ratio T/N	Number of Texts	Load Average
REVIEW ALL (1)	273	273	2.42	.009	4	5.3
REVIEW ALL (2)	270	270	2.52	.009	4	5.8
REVIEW RE "THE" (1)	273	243	5.9	.021	1	11.5
REVIEW RE "THE" (2)	285	255	5.4	.018	1	3.8
REVIEW RE "THE" (3)	273	243	5.0	.018	1	3.9
REVIEW RE "ANY"	273	34	7.6	.027	2	3.1
REVIEW RE "EXPERIMENTS"	273	14	8.2	.030	1	6.1
REVIEW RE "ZQX"	273	0	7.5	.027	2	4.6
REVIEW ENTRIES BY VALLEE (1)	280	100	2.3	.008	1	0.4
REVIEW ENTRIES BY VALLEE (2)	273	93	2.5	.009	3	6.7
REVIEW ENTRIES BY McCOWN (1)	280	3	2.3	.008	1	0.4
REVIEW ENTRIES BY McCOWN (2)	273	3	2.3	.008	3	2.6
REVIEW ALL	285	285	2.2	.008	2	1.7

Figure 30. Retrieval Statistics for Conference #1

Review Criterion	Number of Entries (N)	Entries Retrieved (R)	CPU Time Seconds (T)	Ratio T/N	Number of Texts	Load Average
REVIEW RE "EXPERIMENTS"	371	18	9.7	.026	2	1.6
REVIEW RE "THE"	371	259	8.0	.022	1	1.8
REVIEW RE "ANY"	371	50	9.6	.026	2	1.2
REVIEW RE "ZQX"	371	0	9.3	.025	2	1.5

Figure 31. Retrieval Statistics for Conference #2

REFERENCES

BIBLIOGRAPHY

- Bailey, Gerald C., Peter G. Nordlie, and Frank Sistrunk, "Literature Review, Field Studies, and Working Papers", Institute for Defense Analysis, Research Paper P-113 (October 1963, revised March 1966).
- Communications Studies Group: Final Report September 1973*, Vol. 1-3, a report to the Management Services Division of the Civil Service Department and the Long Range Studies Division of the Post Office (1973).
- Conrath, David W., "Teleconferencing: The Computer, Communication, and Organization", *Proceedings of the First International Conference on Computer Communication* (1972).
- Hall, Thomas W., "Implementation of an Interactive Conference System", *Proceedings of the Spring Joint Computer Conference* (1971).
- Reid, Alex, "New Directions in Telecommunications Research", a report prepared for the Sloan Commission on Cable Communications (June 1971).
- Schuyler, James A. and Robert Johansen, "Oracle: Computerized Conferencing in a Computer-Assisted Instruction System", *Proceedings of the First International Conference on Computer Communication* (1972).
- Sheridan, Thomas B., "Technology for Group Dialogue and Social Choice", *Proceedings of the Fall Joint Computer Conference* (1971).
- Turoff, Murray, "Delphi Conferencing: Computer-based Conferencing with Anonymity", *Technological Forecasting and Social Change*, Vol. 3, No. 2 (1972).
- Turoff, Murray, "Human Communication via Data Networks", *Computer Decisions* (January 1973).
- Turoff, Murray, "Party-line and Discussion Computerized Conference Systems", *Proceedings of the First International Conference on Computer Communication* (1972).

PAPERS FROM THE FORUM PROJECT

Amara, Roy, and Jacques Vallee, "FORUM: A Computer-Based System to Support Interaction among People", to be presented at IFIP Congress '74 (August 1974).

Baran, Paul, "Voice-Conferencing Arrangement for an On-Line Interrogation", Institute for the Future (March 1973).

Baran, Paul, Hubert M. Lipinski, Richard H. Miller, and Robert H. Randolph, "ARPA Policy-Formulation Interrogation Network", Semiannual Technical Report to Advanced Research Projects Agency under Contract DAHC 15 72 C 0165 (April 1973).

Helmer, Olaf, "Toward the Automation of Delphi", Internal Technical Memorandum, Institute for the Future (March 1970).

Institute for the Future, "Development of a Computer-Based System to Improve Interaction Among Experts", First Annual Report to the National Science Foundation under Grant GJ-35 326X (August 1973).

Institute for the Future, "Social Assessment of Mediated Group Communication: A Workshop Summary" (March 1974).

Johansen, Robert, Richard H. Miller, and Jacques Vallée, "Group Communication Through Electronic Media: Fundamental Choices and Social Effects" (Institute for the Future Working Paper, March 1974).

Johansen, Robert, and Richard H. Miller, "The Design of Social Research to Evaluate a New Medium of Communication", a working paper prepared for the American Sociological Association Annual Meeting (February 1974).

Lipinski, Andrew J., Hubert M. Lipinski, and Robert H. Randolph, "Computer-Assisted Expert Interrogation, A Report on Current Methods Development", *Proceedings of the First International Conference on Computer Communication* (1972).

Lipinski, Hubert M., and Richard H. Miller, "FORUM: A Computer-Assisted Communications Medium", Institute for the Future Working Paper (December 1973).

Lipinski, Hubert M., and Robert H. Randolph, "Conferencing in an On-line Environment: Some Problems and Possible Solutions", *Proceedings of the Second Annual Computer Communications Conference* (1973).

Miller, Richard H., "Trends in Teleconferencing by Computer", *Proceedings of the Second Annual Computer Communications Conference* (1973).

Vallee, Jacques, "Network Conferencing", *Datamation* (May 1974).