

AD/A-005 316

FARADAY ROTATION MEASUREMENTS OF
MEGAGAUSS MAGNETIC FIELDS IN LASER-
PRODUCED PLASMAS

J. A. Stamper, et al

Naval Research Laboratory

Prepared for:

Atomic Energy Commission

January 1975

DISTRIBUTED BY:

NTIS

National Technical Information Service
U. S. DEPARTMENT OF COMMERCE

REPORT DOCUMENTATION PAGE		READ INSTRUCTIONS BEFORE COMPLETING FORM
1. REPORT NUMBER NRL Memorandum Report 2986	2. GOVT ACCESSION NO.	3. RECIPIENT'S CATALOG NUMBER AD/A-CO5316
4. TITLE (and Subtitle) FARADAY ROTATION MEASUREMENTS OF MEGAGAUSS MAGNETIC FIELDS IN LASER- PRODUCED PLASMAS	5. TYPE OF REPORT & PERIOD COVERED A final report.	
	6. PERFORMING ORG. REPORT NUMBER	
7. AUTHOR(s) J. A. Stamper and B. H. Ripin	8. CONTRACT OR GRANT NUMBER(s)	
9. PERFORMING ORGANIZATION NAME AND ADDRESS Naval Research Laboratory Washington, D.C. 20375	10. PROGRAM ELEMENT, PROJECT, TASK AREA & WORK UNIT NUMBERS NRL Problem 77 H02-29	
11. CONTROLLING OFFICE NAME AND ADDRESS Atomic Energy Commission Germantown, Maryland	12. REPORT DATE January 1975	
	13. NUMBER OF PAGES 13	
14. MONITORING AGENCY NAME & ADDRESS (if different from Controlling Office)	15. SECURITY CLASS. (of this report) Unclassified	
	15a. DECLASSIFICATION/DOWNGRADING SCHEDULE	
16. DISTRIBUTION STATEMENT (of this Report) Approved for public release; distribution unlimited.		
17. DISTRIBUTION STATEMENT (of the abstract entered in Block 20, if different from Report)		
18. SUPPLEMENTARY NOTES		
19. KEY WORDS (Continue on reverse side if necessary and identify by block number) Laser-plasma Magnetic fields Faraday rotation Laser reflection		
20. ABSTRACT (Continue on reverse side if necessary and identify by block number) Magnetic fields in the magagauss range have been observed in the laser-produced plasma near the focus of a high power laser pulse. Faraday rotation measurements, utilizing the light of a probing beam and the specularly reflected laser light, both show the presence of these large fields.		

Reprinted by
NATIONAL TECHNICAL
INFORMATION SERVICE
U.S. Department of Commerce
Springfield, VA 22151

PRICES SUBJECT TO CHANGE

FARADAY ROTATION MEASUREMENTS OF MEGAGAUSS
MAGNETIC FIELDS IN LASER-PRODUCED PLASMAS

We report here the first direct observations of spontaneous megagauss magnetic fields in laser-produced plasmas. Spontaneous magnetic fields have previously been measured in laser-produced plasmas formed when a high power laser pulse was focused onto a solid target,¹⁻³ or into a gas.⁴ The earlier measurements were made with magnetic probes at some distance from the laser focus. Although these fields, measured in the expanding plasma, were as large as a kilogauss,² theory^{2,5-7} predicts that very large fields (megagauss) exist in the focal region. The megagauss fields may be of considerable importance since they can affect the physics of laser fusion in a variety of ways.⁸⁻¹¹ The direct observation of large magnetic fields should stimulate further theoretical studies of their effect on laser fusion.

It has been recognized that measurements of magnetic fields in the focal region require optical techniques since magnetic probes cannot give reliable data closer than three or four mm from the focus.¹¹ In this article we describe two independent measurements involving Faraday rotation of electromagnetic waves. One method uses a probing beam of second harmonic light ($0.53 \mu\text{m}$) with the data recorded on film. The other method uses the light ($1.06 \mu\text{m}$) which is specularly reflected from the critical surface of the plasma and depends on measuring (with

Note: Manuscript submitted January 9, 1975.

photodiodes) both components emerging from a polarizing prism. The methods are thus independent and complementary. Analysis shows that the results of both methods are consistent with magnetic fields in the megagauss range. A brief theoretical discussion is given which shows that megagauss magnetic fields in the observed direction are expected for the reported experimental conditions.

The laser system used in these studies consists of a Nd-doped mode-locked, mode-selected YAG oscillator with a Nd-doped glass amplifier chain.¹¹ Pulse width for the studies reported here was 100 psec; pulse energy was typically two joules. The laser beam was focused with a three inch diameter, f/14 lens producing an irradiance of about 10^{15} W/cm². Targets were located in a vacuum chamber having a base pressure around 10^{-4} Torr.

The experimental arrangement for studies using a probing beam are shown in Fig. 1a. The probing beam was obtained by splitting off part of the main laser beam and frequency doubling it to 0.53 μ m. This green probing beam was passed parallel to the target surface and timed to arrive around 200 psec after the main laser pulse (which arrives at normal incidence onto a slab target). The probing beam and main laser beam were vertically polarized. That portion of the probing beam which passes through the laser-produced plasma was focused, with a 4:1 magnification, onto photographic film. The film was protected against room light by opening a shutter only a few seconds before firing the laser. Plasma light was discriminated against by using a broad band blocking filter and a narrow band interference filter (50 \AA width centered at 0.53 μ m).

Exposures were taken of the probing beam with a polarizing sheet placed in front of the shutter. As expected, with no main laser beam, the film was dark when the polarizing sheet was oriented horizontally. The effect of plasma light was checked by taking exposures with the probing beam blocked and found to be negligible. However, when the probing beam was passed through the laser-produced plasma in the focal region, a distinct lighted pattern could be seen on the film. See Fig. 1b for data for an aluminum target.

The lighted pattern is what one would expect for green light rotated by the spontaneous magnetic fields so that it can pass through the polarizing sheet. These fields are primarily in an azimuthal direction about the target normal with a maximum off-axis (since the maximum gradients are off-axis). The central region at the target surface is dark since refraction and reflection prevent light from passing through this high density region. For azimuthal magnetic fields due to thermal sources, the magnetic field above focus is parallel to the probing beam and that below center is antiparallel.² One would thus expect an up-down asymmetry in the lighted pattern when the polarizing sheet is rotated. Rotation of the polarizing sheet, Fig. 1b (right), was in the direction to enhance the transmission of light which had been given a Faraday rotation of positive helicity. The fact that the lighted region was at the bottom is consistent with fields generated from thermal sources. By rotating the polarizing sheet until the background exposure (for probing beam only) is comparable to that of the lighted region, we estimate a typical rotation angle to be about 0.2 radian.

We can estimate the magnetic field magnitude required for this Faraday rotation from the expression for the rate of change of rotation angle φ with respect to distance z along the propagation direction,

$$\frac{d\varphi}{dz} = \frac{1}{2} \left(\frac{\omega_p}{\omega} \right)^2 \frac{\omega_{cz}}{c}, \quad (1)$$

where ω_p and ω are, respectively, the plasma and laser frequencies. The magnetic field dependence ω_{cz}/c , is given in cm^{-1} by $0.586 B_{\parallel}$ (kG) where $B_{\parallel} = B_0 \cos \theta$, and where the angle between the magnetic field and propagation direction of the electromagnetic wave is denoted by θ . We have tried a variety of density and magnetic field variations guided by experimental results, simple models and computer calculations. The implied magnetic fields agree within a factor of 3 or 4. For example, assume the density varies down from the critical density (10^{21} cm^{-3}) at a $35 \mu\text{m}$ focal radius and that the probing light passes $100 \mu\text{m}$ (radius of lighted region) from the focal center. Then, if we assume the density decreases exponentially with radius from the critical surface and the field varies inversely as the radial position,² a rotation angle of .2 radian corresponds to a maximum field of 4.8 megagauss. The scale length ($35 \mu\text{m}$) for density variation was obtained from interferometry.

The other experimental method utilized the laser light specularly reflected from the critical surface of the plasma. Large gradients in the electron pressure and laser intensity occur in the critical region and, since these are involved in the field generation, the largest fields occur near the critical region. Hence, the specularly reflected light is inherently timed and positioned to sample the large magnetic

fields. However, the specularly reflected light sampled by our detector involves some spatial and temporal averaging which limits the magnetic field information.

The experimental arrangement for the specular reflection measurements is shown in Fig. 2a. The laser light is focused onto a target inclined at 45° to the laser beam. Laser light, specularly reflected from the critical surface is thus centered at 90° to the incident beam.¹² This light is analyzed with a polarizing prism. Each component of polarization is measured with a photodiode-oscilloscope system having a 2 nsec response. The data is thus time-integrated for the 100 psec laser pulses used.

Some experimental results are shown in Fig. 2b. On some shots (left) with the detector assembly oriented vertically, appreciable signals are observed on both channels. This suggests rotation but could also be due to depolarization. Some depolarization is always present and is expected from Faraday rotation due to the mixing of signals implied by space and time averaging. However, on some shots with the detector assembly rotated we see a rather high degree of polarization. This is clear evidence of a net rotation of the detected beam through approximately the angle of inclination of the detector assembly. The signals on the right in Fig. 2b were for a detector set at $22\frac{1}{2}^\circ$ and imply a rotation of about that angle. Typical rotations were approximately this value but due to competing depolarization effects, were not as accurately determined.

Equation (1) can be used to estimate¹³ the magnetic field required to produce a $\pi/8$ radian rotation in the specularly reflected light.

A rough estimate can be made by assuming that the laser light comes in and out of the critical region along a radius and that the density and magnetic field have particular radial variations. For example, assuming that $\cos \theta$ has a value of 0.2 (discussed below) and that the density and magnetic field have the radial variations used previously, then a $\pi/8$ rotation corresponds to a 1.6 megagauss magnetic field. A number of reasonable density and magnetic field variations have been assumed as a test. We find that the implied magnetic fields agree with this value to within a factor of three to four.

Magnetic fields of a few megagauss are expected from numerical studies^{5,6} and simple models.⁷ The numerical studies, utilizing 2-D computer codes, have been based on thermal source terms. Here the magnetic source term \underline{S} or time rate of change of the field is given by $(ck/ne) \nabla T \times \nabla n$. Since the density gradient has a large component normal to the target surface and the temperature gradient has a large component radially outward, the initial fields are, as observed, clockwise in an azimuthal direction about the target normal. For a 1 keV temperature, with temperature and density length scales of 35 μm , $|\underline{S}|$ is about 10 MG/nsec. Thus fields in the megagauss range can be generated during the 100 psec laser pulse.

Since thermally generated fields for 45° incidence onto the target will be primarily in an azimuthal direction about the normal to the target, the specularly reflected light from the central part of the critical region will be almost perpendicular to the thermally generated fields. At 10^{15} W/cm² the magnetic fields generated from the plasma thermal energy are dominant. However, since the specularly reflected

light samples only a small component of this field it also may be affected by fields generated by radiation pressure and polarization effects.⁷ Radiation pressure at 10^{15} W/cm² is about one-tenth of the electron pressure at 1 keV and 10^{21} cm⁻³. These effects complicate the field geometry. For example, polarization effects produce a field component along the propagation direction even for normal incidence onto the target. From these considerations, a typical angle between the field and propagation direction is taken as 80° so that $\cos \theta$ was taken as 0.2 in the example cited. The average $\cos \theta$ sampled by the detected light should agree with this value within a factor of two.

In summary, we have described two independent measurements of the magnetic fields generated at the focus of a high power laser pulse interacting with a solid target. These measurements depend upon Faraday rotation of plane polarized electromagnetic radiation traversing the region of high fields. Taken together, the measurements demonstrate that megagauss magnetic fields do exist in the focal region.

We acknowledge discussions with E. A. McLean and J. M. McMahon.

REFERENCES

1. G. A. Askar'yan, M. S. Rabinovich, A. D. Smir'nova and V. B. Studenov, J.E.T.P. Letters 5, 93 (1967). This paper reports currents which are attributed to light pressure.
2. J. A. Stamper, K. Papadopoulos, R. N. Sudan, S. O. Dean, E. A. McLean and J. M. Dawson, Phys. Rev. Letters 26, 1012 (1971). This paper reports large (kG) magnetic fields and explains the fields in terms of thermal sources.
3. F. Schwirzke and L. L. McKee, Proceedings of the Fifth European Conference on Controlled Fusion and Plasma Physics, CEA, Grenoble, France, 1, 63 (1972). These researchers at the Naval Postgraduate School, made a detailed mapping of the magnetic fields.
4. V. V. Korobkin and R. V. Serov, JEPT Lett. 4, 70 (1966). This paper reported a small magnetic moment ($3-5 \times 10^{-2}$ Oe-cm³) which was dependent on some asymmetry (e.g., displaced lens) in the illumination.
5. J. B. Chase, J. M. LeBlanc and J. R. Wilson, Phys. Fluids 16, 1142 (1973).
6. N. K. Winsor and D. A. Tidman, Phys. Rev. Letters 31, 1044 (1973).
7. J. A. Stamper, NRL Report 7411, June 1972. J. A. Stamper and D. A. Tidman, Phys. Fluids 16, 2024 (1973). J. A. Stamper, submitted to Phys. Fluids, Sep 1974.
8. J. Nuckolls, L. Wood, A. Thiessen and G. Zimmerman, Nature 239, 133 (1972).

9. J. S. Clarke, H. N. Fisher and R. G. Mason, Phys. Rev. Letters 30, 89 (1973).
10. J. Nuckolls, Contribution to LLL Laser-Fusion Program Semiannual Report, July-December 1973, (UCRL Report 50021-73-2), p. 76.
11. J. A. Stamper, O. C. Barr, J. Davis, G. A. Doschek, C. M. Dozier, A. Feldman, B. M. Klein, W. M. Manheimer, E. A. McLean, J. M. McMahon, D. J. Nagel, D. A. Tidman, R. R. Whitlock, K. Whitney, N. K. Winsor and F. C. Young, Chapter in Laser Interaction and Related Plasma Phenomena, Vol. 3 (H. Schwarz and H. Hora, Eds.) Plenum, New York (1974).
12. B. H. Ripin, J. M. McMahon, E. A. McLean, W. M. Manheimer and J. A. Stamper, Phys. Rev. Letters 33, 634 (1974).
13. Equation (1) is strictly valid only in the underdense region where $\omega \gg \omega_p$. However, the inaccuracy in using it to calculate the total angle is less than that introduced by the uncertainty in the exact density and magnetic field variations.

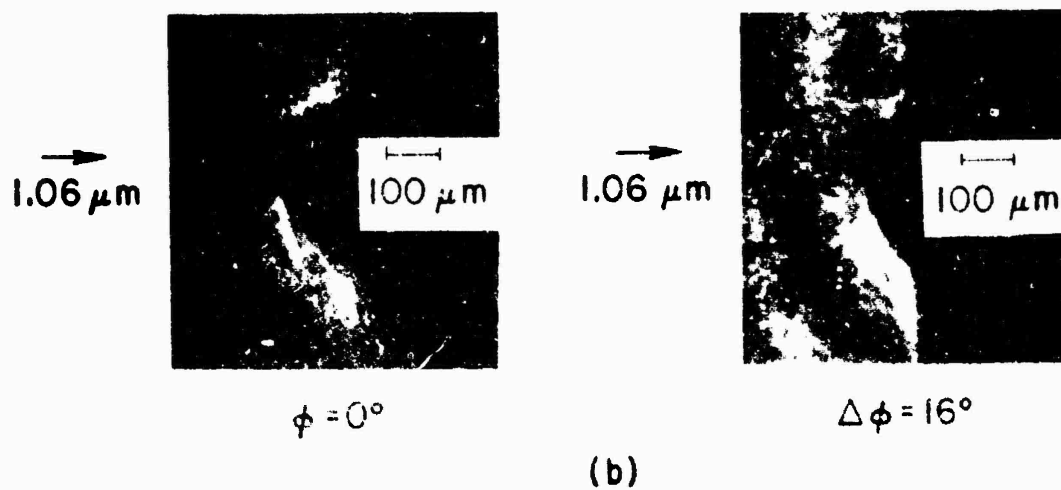
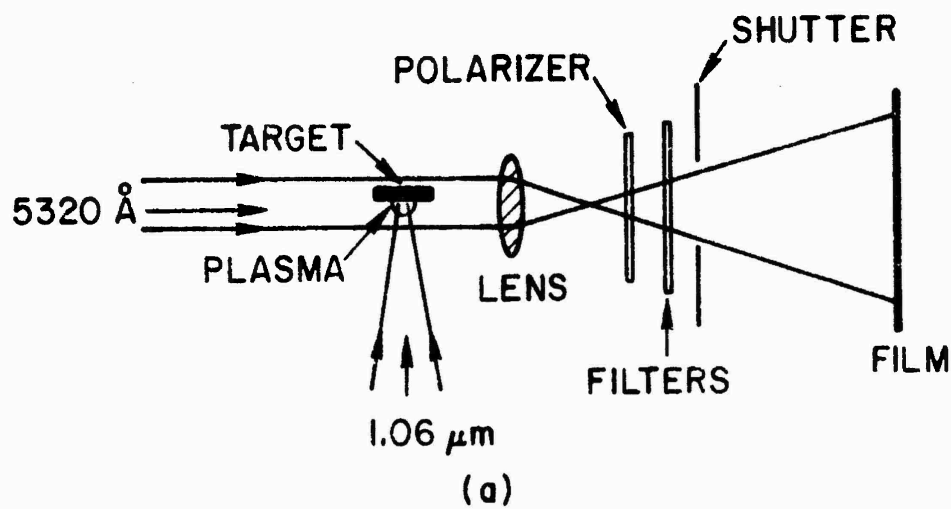

Fig. 1 -- Measurements of Faraday rotation of a probing beam. (a) Arrangement for detecting the rotation of polarization. (b) Sample photographs as a function of polarizing sheet orientation.

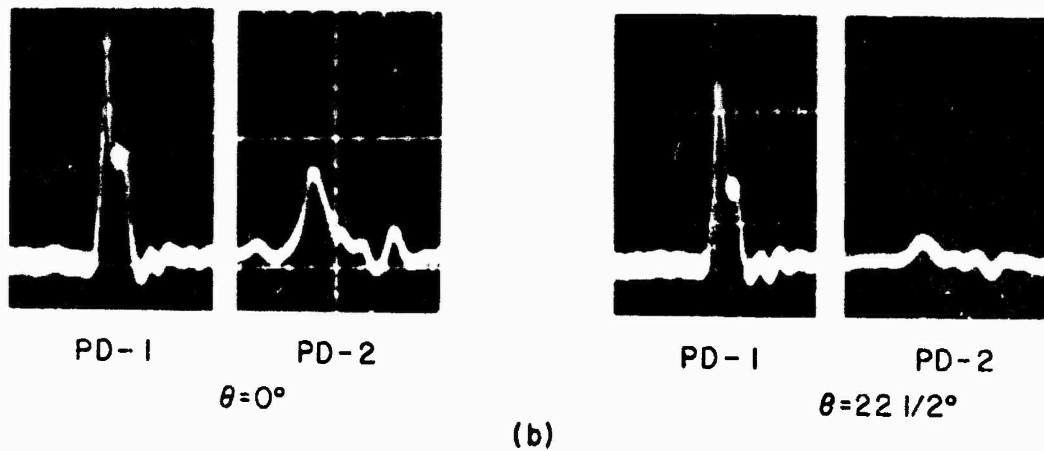
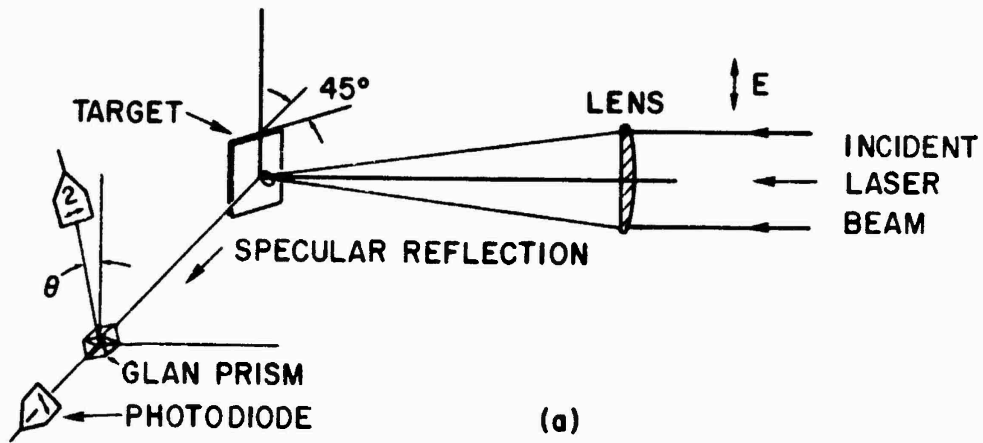

Fig. 2 — Measurements of Faraday rotation of specularly reflected light. (a) Arrangement for detecting the rotation of polarization. Arrows indicate the directions of polarization (mutually perpendicular). The whole detector can be rotated by an angle θ . (b) Photodiode outputs for detector assembly set at $\theta = 0$ (left) and at $\theta = 22\frac{1}{2}^\circ$ (right).