

AD/A-005 426

WEAPON SYSTEM COSTING METHODOLOGY FOR
AIRCRAFT AIRFRAMES AND BASIC STRUCTURES.
VOLUME II. SUPPORTING DESIGN SYNTHESIS
PROGRAMS

R. E. Kenyon

General Dynamics

Prepared for:

Air Force Flight Dynamics Laboratory

September 1974

DISTRIBUTED BY:

NTIS

National Technical Information Service
U. S. DEPARTMENT OF COMMERCE

UNCLASSIFIED

SECURITY CLASSIFICATION OF THIS PAGE (When Data Entered)

REPORT DOCUMENTATION PAGE		READ INSTRUCTIONS BEFORE COMPLETING FORM
1. REPORT NUMBER A'FFDL-TR-73-129, VOLUME II	2. GOVT ACCESSION NO.	3. RECIPIENT'S CATALOG NUMBER AD/A-005426
4. TITLE (and Subtitle) Weapon System Costing Methodology for Aircraft Airframes and Basic Structures	5. TYPE OF REPORT & PERIOD COVERED Interim Technical Report July 1972 - December 1973	
	6. PERFORMING ORG. REPORT NUMBER	
7. AUTHOR(s) R. E. Kenyon	8. CONTRACT OR GRANT NUMBER(s) F33615-72-C-2083	
9. PERFORMING ORGANIZATION NAME AND ADDRESS Convair Division of General Dynamics Kearny Mesa Plant, 5001 Kearny Villa Rd. San Diego, CA 92138	10. PROGRAM ELEMENT, PROJECT, TASK AREA & WORK UNIT NUMBERS Project No. 1368 Task 136802	
11. CONTROLLING OFFICE NAME AND ADDRESS Air Force Flight Dynamics Laboratory, Advanced Structures Division, Air Force Systems Command, Wright Patterson AFB, Ohio	12. REPORT DATE September, 1974	
	13. NUMBER OF PAGES 73	
14. MONITORING AGENCY NAME & ADDRESS (if different from Controlling Office)	15. SECURITY CLASS. (of this report) Unclassified	
	15a. DECLASSIFICATION/DOWNGRADING SCHEDULE	
16. DISTRIBUTION STATEMENT (of this Report) Approved for public release; distribution unlimited		
17. DISTRIBUTION STATEMENT (of the abstract entered in Block 20, if different from Report)		
18. SUPPLEMENTARY NOTES Reproduced by NATIONAL TECHNICAL INFORMATION SERVICE U.S. Department of Commerce Springfield, VA 22151		
19. KEY WORDS (Continue on reverse side if necessary and identify by block number) secondary structure synthesis secondary structure weight analysis design trade studies airframe cost estimating aerodynamic surfaces costing airframe structural costing		
20. ABSTRACT (Continue on reverse side if necessary and identify by block number) This volume describes the supporting programs used in conjunction with a cost estimating program to provide a trade study cost estimating technique for aerodynamic surfaces. The supporting programs for the purpose of this discussion are defined as a structural synthesis program and a secondary structure synthesis program. The structural synthesis program is used for the analysis of primary structure and is called APAS (Automated Program for Aerospace-Vehicle Synthesis). The secondary		

DD FORM 1 JAN 73 1473

EDITION OF 1 NOV 65 IS OBSOLETE

UNCLASSIFIED SUBJECT TO CHANGE

/ SECURITY CLASSIFICATION OF THIS PAGE (When Data Entered)

UNCLASSIFIED

SECURITY CLASSIFICATION OF THIS PAGE(When Data Entered)

structure synthesis program estimates geometry and weights, and performs parts definition for the aerodynamic surface leading edge, trailing edge, and tip components. The cost estimating adaptation is derived from programs originally developed under Independent Research and Development.

An operating interface between cost estimating procedures and the synthesis programs has been developed. Dimensional and weight data from the synthesis program outputs are used as explanatory variables in a series of cost estimating relationships. The two synthesis programs also interface with and require inputs from pre-design activities that may also involve computerized programs. The various capabilities and input requirements of the synthesis programs are described. References are provided for those desiring to pursue further the technical descriptions.

ia

UNCLASSIFIED

SECURITY CLASSIFICATION OF THIS PAGE(When Data Entered)

WEAPON SYSTEM COSTING METHODOLOGY FOR AIRCRAFT AIRFRAMES AND BASIC STRUCTURES

VOLUME II • SUPPORTING DESIGN SYNTHESIS PROGRAMS

R.E. Kenyon

General Dynamics Convair Aerospace Division
Kearny Mesa Plant, San Diego Operation
5001 Kearny Villa Road San Diego, California 92112

ik

FOREWORD

Study to adapt Supporting Design Synthesis Programs for cost estimating use was conducted by the Convair Aerospace Division of General Dynamics, San Diego, California, under USAF Contract F33615-72-C-2083. The contract titled "Weapon System Costing Methodology for Aircraft Airframes and Basic Structures," was initiated under Project 1368, "Advanced Structures for Military Aerospace Vehicles," Task 136802, "Structural Integration for Military Aerospace Vehicles." The work was administered under the direction of the Air Force Flight Dynamics Laboratory, Structures Division, Wright-Patterson Air Force Base, Ohio, under the direction of Mr. R. N. Mueller (AFFDL/FBS) as Project Engineer.

This report covers work conducted from July, 1972 to November, 1973 and was submitted by the author in December, 1973, under General Dynamics Report CASD-AFS-73-001 as an Interim Technical Report. The principal author and project leader on this program is Mr. R. E. Kenyon of Convair Aerospace. Others who contributed to these studies include Messrs. B. H. Oman and W. D. Honeycutt, Mass Properties; and L. M. Peterson and J. R. Hotz, Structural Analysis.

This report has been reviewed and is approved for publication.

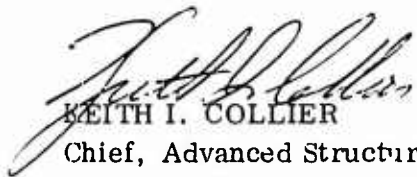

KEITH I. COLLIER

Chief, Advanced Structures Branch
Structures Division
Air Force Flight Dynamics Laboratory



R. N. Mueller
Project Engineer, FBR
Structures Design
Air Force Flight Dynamics Laboratory

ABSTRACT

This volume describes the supporting programs used in conjunction with a cost estimating program to provide a trade study cost estimating technique for aerodynamic surfaces. The supporting programs for the purpose of this discussion are defined as a structural synthesis program and a secondary structure synthesis program. The structural synthesis program is used for the analysis of primary structure and is called APAS (Automated Program for Aerospace-Vehicle Synthesis). The secondary structure synthesis program estimates geometry and weights, and performs parts definition for the aerodynamic surface leading edge, trailing edge, and tip components. The cost estimating adaptation is derived from programs originally developed under Independent Research and Development.

An operating interface between cost estimating procedures and the synthesis programs has been developed. Dimensional and weight data from the synthesis program outputs are used as explanatory variables in a series of cost estimating relationships. The two synthesis programs also interface with and require inputs from pre-design activities that may also involve computerized programs. The various capabilities and input requirements of the synthesis programs are described. References are provided for those desiring to pursue further the technical descriptions.

TABLE OF CONTENTS

Section		Page
I	INTRODUCTION	1
II	MULTISTATION STRUCTURAL SYNTHESIS PROGRAM	4
	2.1 MODEL DESCRIPTION	7
	2.2 EXTERNAL LOADS	10
	2.3 INTERNAL LOADS DISTRIBUTION	10
	2.4 MATERIALS	11
	2.5 COMPONENT ANALYSIS	11
	2.5.1 Covers	12
	2.5.2 Spar Caps	12
	2.5.3 Spar Webs	13
	2.5.4 Ribs	14
	2.6 FLIGHT SAFETY ANALYSIS	17
	2.6.1 Safe Life	19
	2.6.2 Fail Safe	20
	2.6.3 Fatigue	21
	2.7 AEROELASTIC EFFECTS	21
	2.8 WEIGHTS	22
	2.9 APAS PROGRAM INPUTS	22
III	SECONDARY STRUCTURE SYNTHESIS	31
	3.1 TIP, LEADING AND TRAILING EDGE ANALYSIS ...	31
	3.2 TIP, LEADING AND TRAILING EDGE PART DEFINITION	46
	3.3 COMPUTER PROGRAM	50
	3.3.1 Program Description	50
	3.3.2 Description of Subroutines	53
	3.3.3 User's Guide	55
IV	REFERENCES	63

LIST OF ILLUSTRATIONS

Figure		Page
1	AFFDL Trade Study Cost Estimating Method	2
2	Cost Estimating Procedures - Design Synthesis Interface	3
3	Flow Diagram for Synthesis Program Inputs	5
4	APAS Function Flow Chart	6
5	Control Stations	7
6	Box Configurations	8
7	Typical Section Definition	9
8	Panel Definition	9
9	Typical Spar Cap Model - Built Up Web	13
10	Built Up Web	15
11	Integral Web	15
12	Corrugated Web	16
13	Truss	16
14	Rib Element	15
15	Leading Edge and Trailing Edge Synthesis Routines	32
16	Spoiler Geometry	35
17	Foreflap Geometry	38
18	Typical Geometry for the Flaps, Slats, Ailerons, Rudder and Elevators	41
19	Sonic Fatigue Curve	45
20	Fixed Trailing Edge	48
21	Wing Tip	51
22	Typical Overlay Structure	52
23	Deck Setup for LTTWPD	55

LIST OF TABLES

Table		Page
1	Standard Sheet Gages	37
2	Standard Extrusion Gages	40
3	Subroutine Core Requirements	53
4	List of Inputs	56
5	Aileron Input	59
6	Rudder Input	59
7	Elevator Input	59
8	Flap Input	60
9	Slat Input	60
10	Fore Flap Input	60
11	Leading Edge Input	60
12	Trailing Edge Input	61
13	Spoiler Input	61
14	Sample Output	62

NOTICE

When Government drawings, specifications, or other data are used for any purpose other than in connection with a definitely related Government procurement operation, the United States Government thereby incurs no responsibility nor any obligation whatsoever; and the fact that the government may have formulated, furnished, or in any way supplied the said drawings, specifications, or other data, is not to be regarded by implication or otherwise as in any manner licensing the holder or any other person or corporation, or conveying any rights or permission to manufacture, use, or sell any patented invention that may in any way be related thereto.

ACCESSION for	
NTIS	White Service <input checked="" type="checkbox"/>
D. C.	Reference <input type="checkbox"/>
UN-	<input type="checkbox"/>
JCS/...	
BY	
DISPATCH AND MANIPULATION CODES	
SIGNATURE	

Copies of this report should not be returned unless return is required by security considerations, contractual obligations, or notice on a specific document.

SECTION I

INTRODUCTION

This volume describes the supporting programs used in conjunction with the cost estimating program to provide a trade study cost estimating technique for aerodynamic surfaces. The flow diagram of this estimating method, repeated from Volume 1, is shown as Figure 1. The supporting programs for the purpose of this discussion are defined as the structural synthesis program and the secondary structure synthesis program. The structural synthesis program is used for the analysis of primary structure and is called APAS (Automated Program for Aerospace Vehicle Synthesis). The secondary structure synthesis program estimates geometry and weights, and performs parts definition for aerodynamic surface leading edge, trailing edge, and tip components. The operating interface between cost estimating procedures and the synthesis programs is illustrated in Figure 2. These two programs also interface with and require inputs from pre-design activities that may also involve computerized programs. This interface is shown in Figure 3. Although the trade study cost estimating method can be used for a single point-design estimate using manually derived inputs, the basic costing concept requires an interface with computerized design synthesis programs as a primary source of cost-related explanatory variables.

Section 2 describes the multistation structural synthesis program including a description of input requirements. Section 3 describes the secondary structure synthesis program together with inputs required.

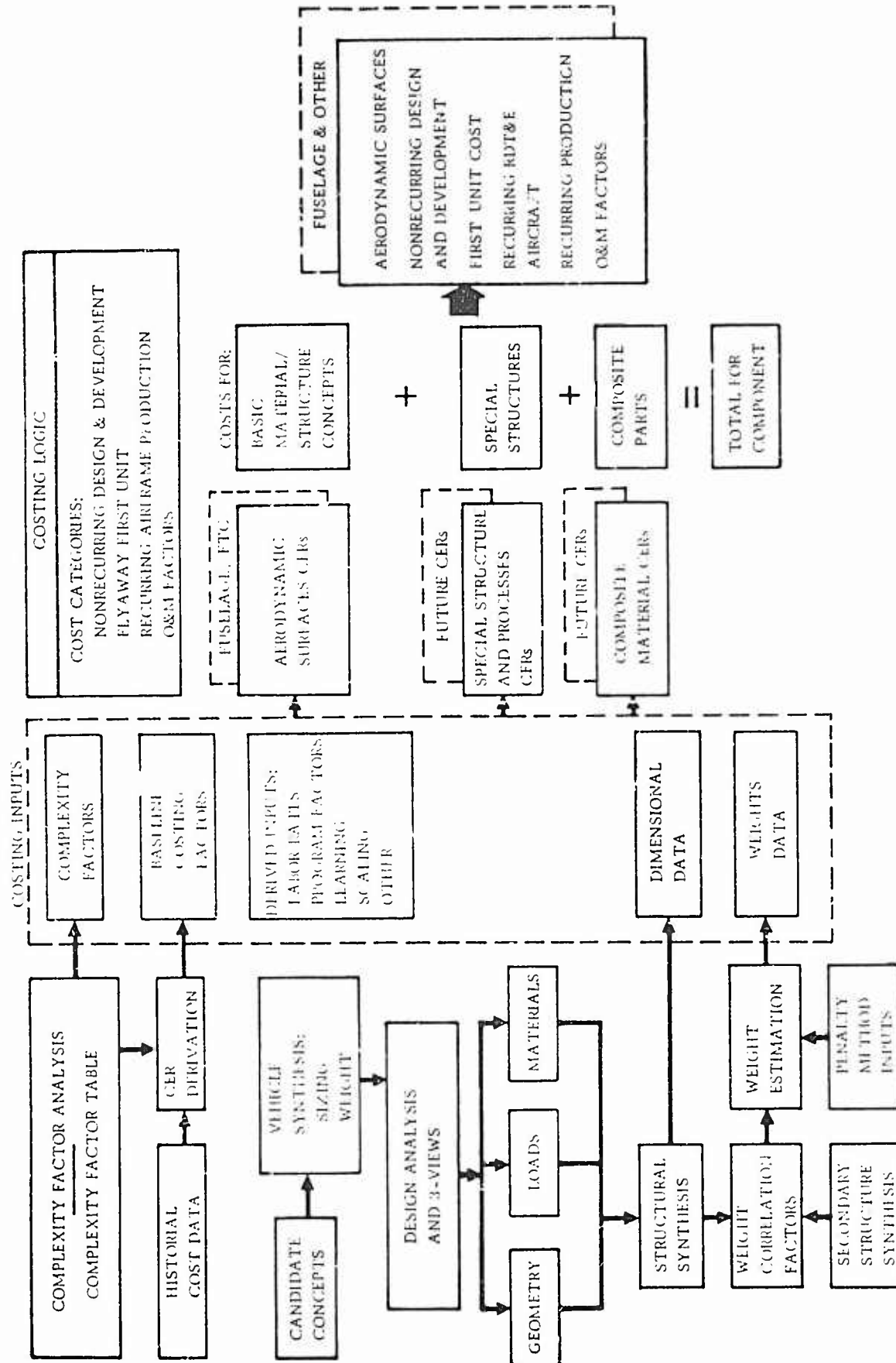

Figure 1. AFFDL Trade Study Cost Estimating Method

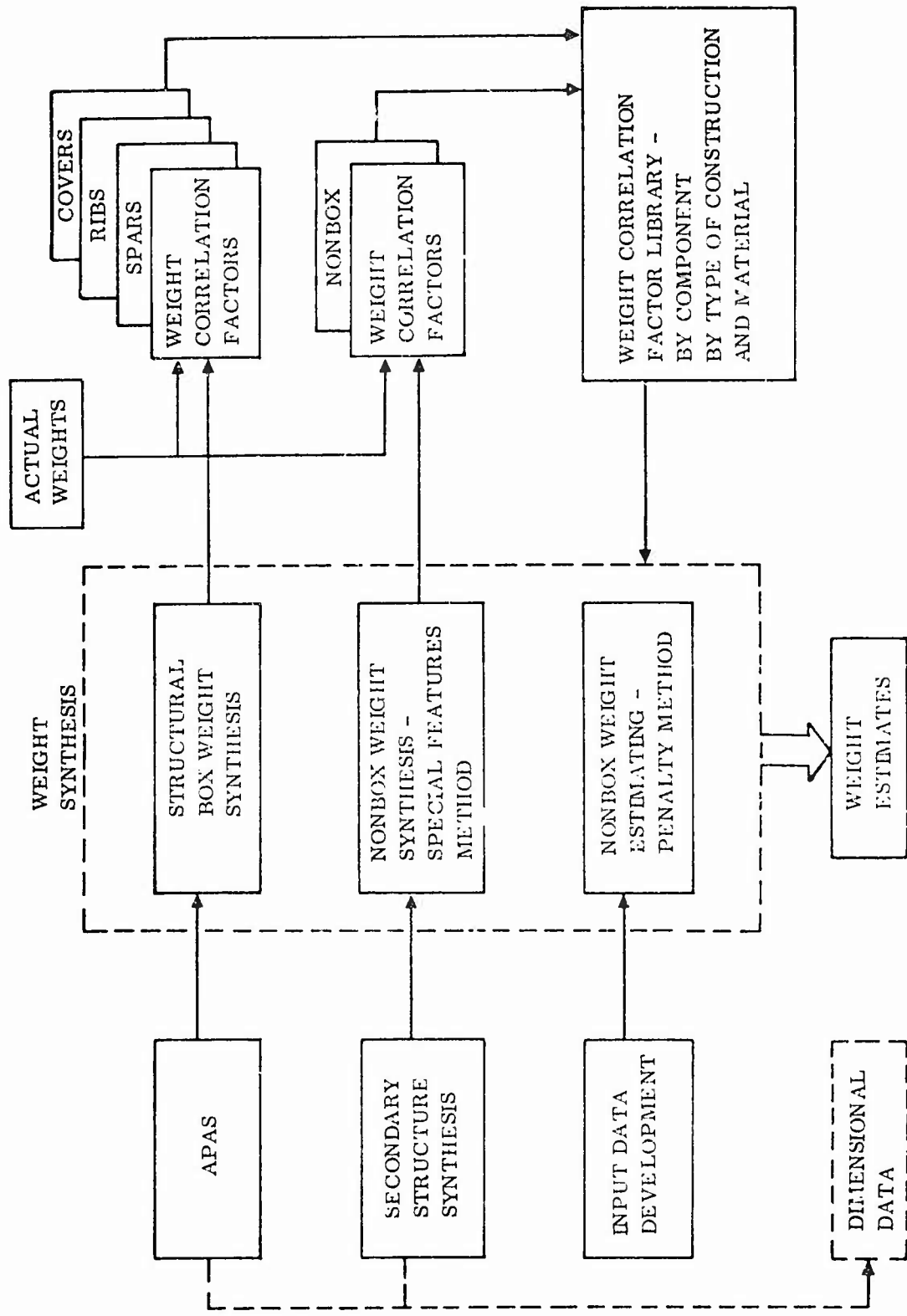

Figure 2. Cost Estimating Procedures-Design Synthesis Interface

SECTION II

MULTISTATION STRUCTURAL SYNTHESIS PROGRAM

Structural synthesis is a way of satisfying the design problem of defining a piece of structure that fulfills requirements of strength geometry and other criteria. It combines material properties, structural analysis techniques and loading environments to produce a consistent design. In broad terms structural synthesis is the replacement of traditional, laborious hand calculations with an automated series of logical steps. It offers real advantages in solution, speed, and accuracy. Mathematical optimization techniques have been incorporated that are untractable by hand calculations.

A multi-station approach is used. Design synthesis proceeds systematically from root to tip, in discrete steps, usually at rib locations, in a two phase system. In the first phase of the synthesis process, a set of initial member size estimates is analyzed. Margins of safety are computed. Thickness variables of all elements are adjusted by iterative steps until each element has a zero margin of safety or until a minimum gage constraint is encountered. The second phase seeks to maximize margins of safety by refinement of element geometry while holding structural weight constant. When this has been accomplished the design is recycled through phase one to further refine structural weight. This logic is repeated until satisfactory convergence is obtained.

The fact that margin of safety maximization rather than weight minimization is used in the second phase permits use of unconstrained function optimization methods. Major advantages of this approach are: the member sizes can be constrained to lay within practical limits of material sizes and manufacturing capability; multiple failure modes may be taken into consideration for each structural element; positive margins of safety are always maintained so that a satisfactory design - from the strength point of view if not the weight - is available at the completion of each iteration.

An accurate representation of geometry is permitted by defining discrete nodes on the contour of the surface. The calculation of internal loads distribution is improved over previous programs by incorporation of methodology for analysis of a multi-cell box beam. Complex bending, shear and torsional loads may be applied. Axial loads and shear flows are computed for each node point and panel. Beams are limited to a maximum of four cells. The discrete nodes used in defining the contours are also used as elemental centers of mass. A spinoff of this modeling scheme is the ability to represent surfaces using the dated constructional mode of concentrating the bending material in the spar caps.

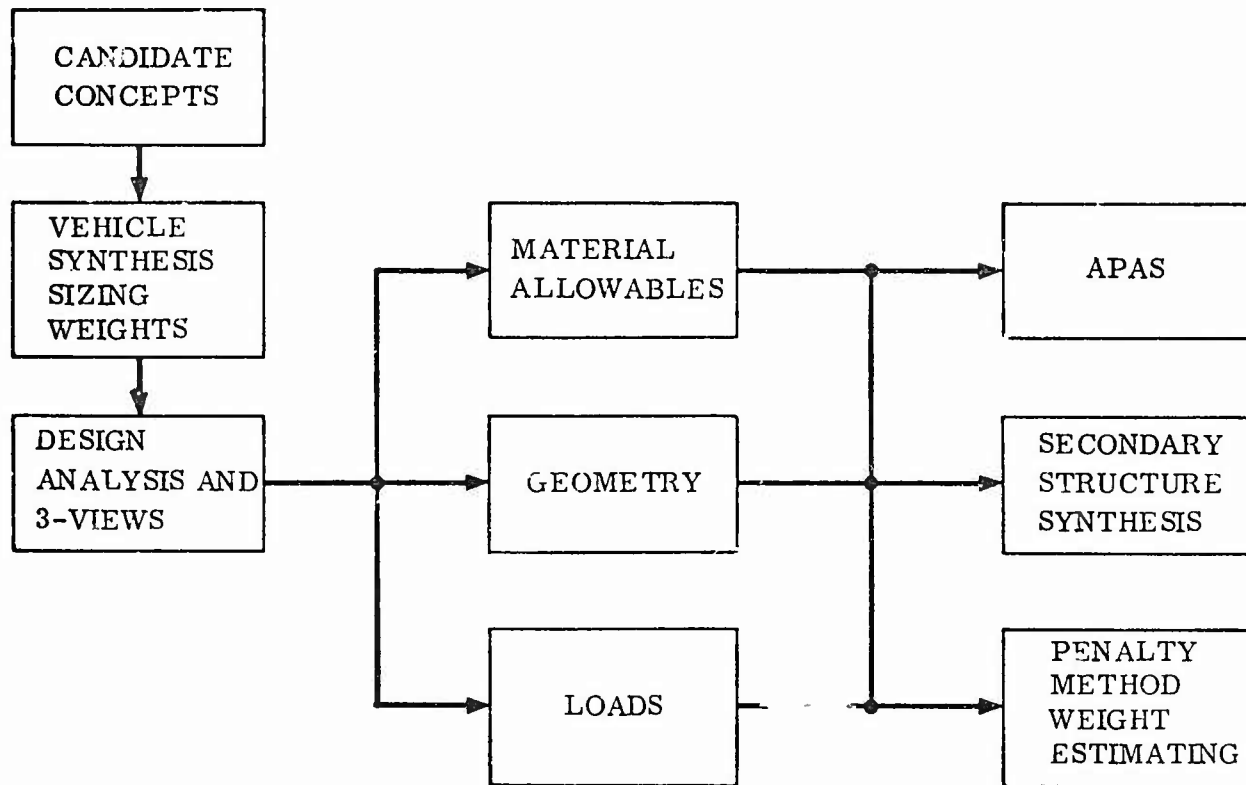

Figure 3. Flow Diagram for Synthesis Program Inputs

The nature of the element determines the failure modes that receive investigation. Typically gross stress, buckling and crippling checks are appropriate. Dimensional constraints may also be viewed as failure modes and geometric margins of safety may be computed.

Flight safety criteria other than static strength are also considered. Aero-elastic phenomena may be investigated to determine flutter and divergence speeds. A review of structural integrity for a given service loading environment can be accomplished by safe life, fail safe or fatigue analysis. These routines and checks are informative in nature and do not initiate a redesign cycle, but serve as flags that a design decision is required. Decisions such as material change, criteria revision, mission revision, etc. are typically considered at this point in design evolution.

The program described herein represents the adaptation of a general multi-station synthesis program, Reference 1, to the particular requirements of aerodynamic surfaces. A function flow chart of the program is given in Figure 4. A program listing is separately available.

2.1 MODEL DESCRIPTION

Aerodynamic surfaces such as wings and tails are usually built around a structural box. If this structural box is reasonably continuous and has an aspect ratio of approximately two or more it can be analyzed by standard methods and synthesized satisfactorily.

The structural box is described for math modeling by careful specification of geometric information at up to twenty control stations (Figure 5). A multi-cell

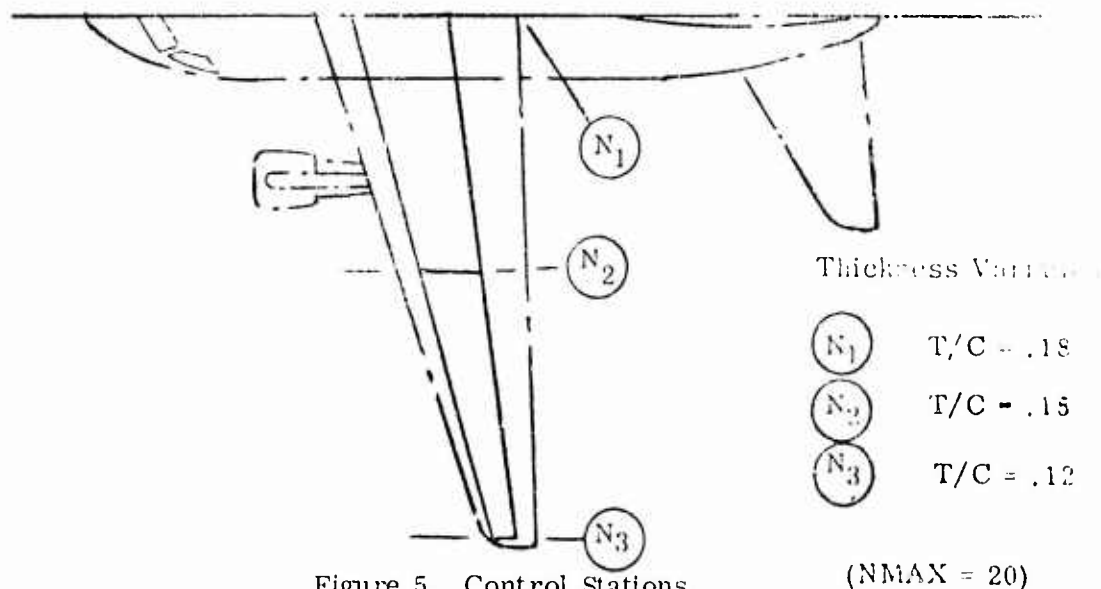

Figure 5. Control Stations.

structure is placed inside the aerodynamic envelope at each control station. Member configuration must be considered and selection of the form of several detail components must be made. Initial estimates of member sizes are satisfactory because the program optimization scheme rapidly converges. A maximum of four torsional cells is permitted (Figure 6).

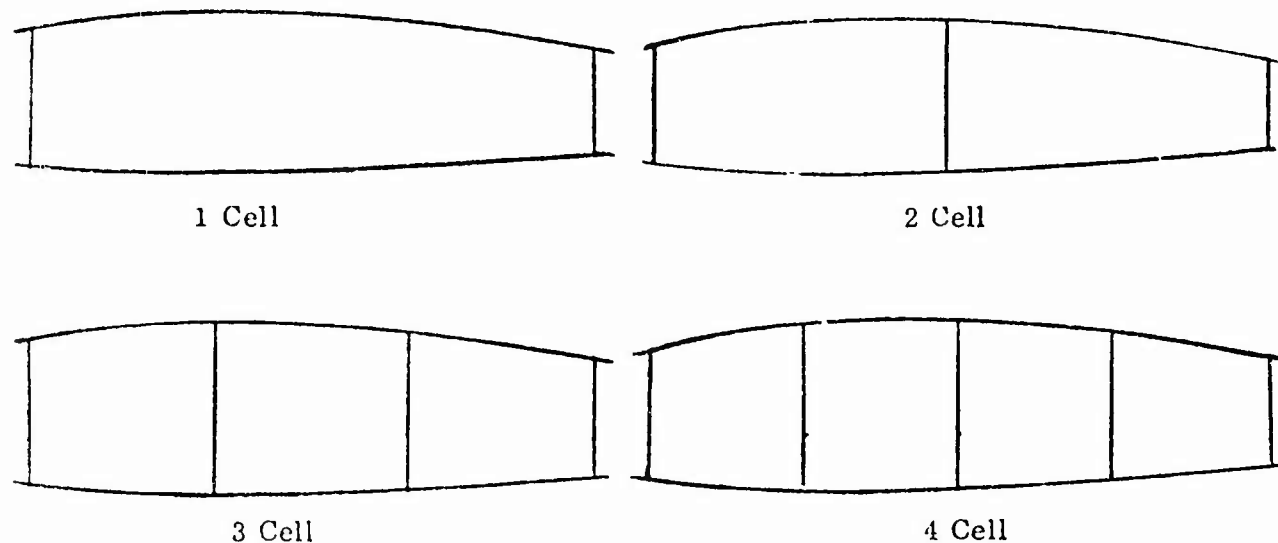

Figure 6. Box Configurations.

Section contours are specified by locating discrete nodal points on the surface (Figure 7). Panels connect these nodes and form the box covers and spar shear webs. Each panel requires a selection of panel types, initial size estimates and a size range that bounds the type dependent design variables. The size range may be used to introduce various design constraints. The lower limit or thickness may be set by machining minimums or handling requirements while the upper limit may be set by available extrusion sizes. Another practical aspect of the constraint feature is the ability to hold certain variables constant. A uniform stringer pitch can be maintained or stringers kept at a constant height.

A sample panel specification is shown in Figure 8 and is typical of the type of decisions required to define panel components. Spar caps, spar webs, rib caps and rib webs require a similar type of specification.

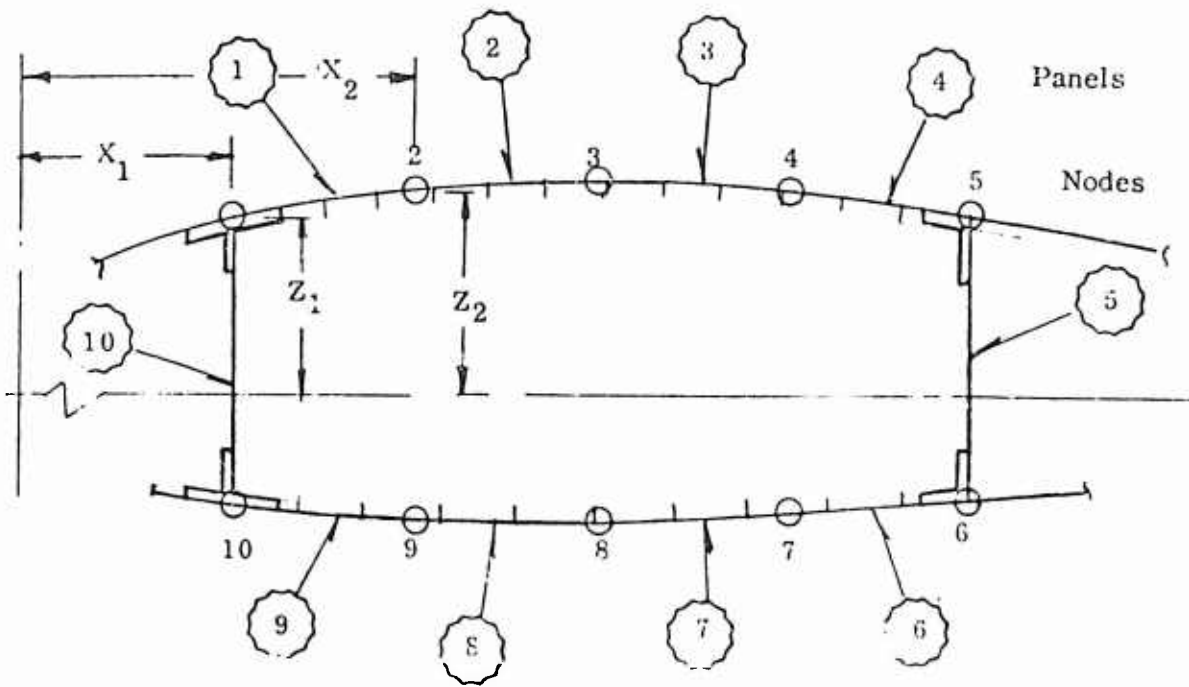
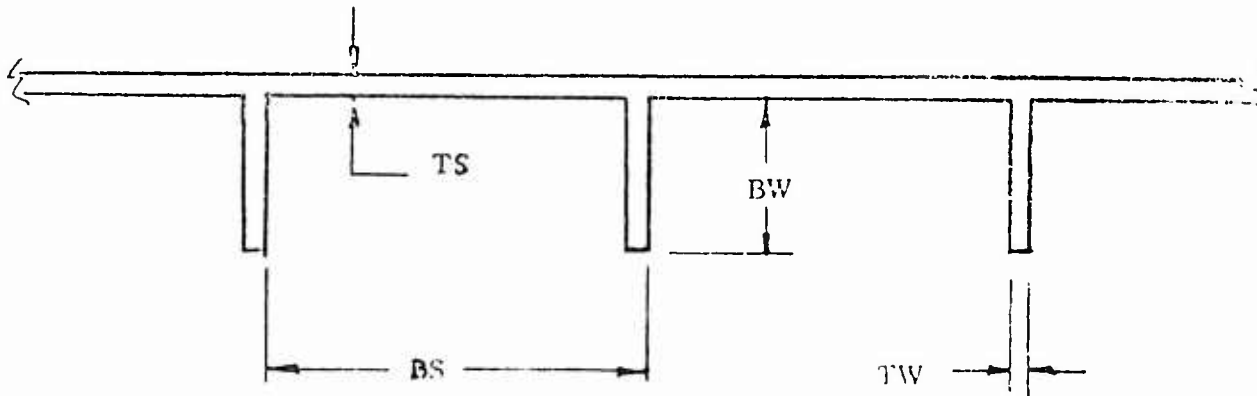

Figure 7. Typical Section Definition.
(Single Cell Box Shown)



Values also required to set range of variables:

SMIN.	BSMIN	BWMIN
TWMIN	BSMAX	BWMAX

Figure 8. Panel Definition.

Rib spacing is not an optimized variable. Practical experience has been that rib locations are almost universally dictated by design requirements, usually the necessity of providing support structure. Rib spacing may be set at each control station and is held constant until reset at another control station. Spar locations must also be re-selected. In general, exploration of the effects of geometric variations of the major structural items, ribs and spars, requires multiple runs.

2.2 EXTERNAL LOADS

External forces for up to six loading conditions may be considered. Loads may be described at a maximum of 20 stations and may contain three shears and three moments. Two load sets may be applied at particular stations to represent discrete load changes that might arise from concentrated loads, external stores, etc.

The program processes each load condition at each load station. Straight line interpolation is used to estimate load values for ribs between stations of load application. Load conditions are treated in a completely consistent fashion. Parts of the box sensitive to a particular loading condition are designed to that condition rather than to an envelope.

Special loads data is required for flight safety analysis. Fail safe analysis requires a scaled down load factor. Cyclic loads information is required to investigate safe life and fatigue effects.

2.3 INTERNAL LOADS DISTRIBUTION

It is possible to compute a reasonable estimate of the internal loads distribution for many aircraft components by simple beam theory. The structure under consideration must be capable of being modeled as a beam. It should have continuity and a reasonably well defined elastic axis. The necessary section properties, bending and torsional moments of inertia and cross-section areas are computed in the program. External loads are then applied at each station, transferred to the section elastic axis and used to derive a set of internal loads for each external loading condition.

Distribution of shears around the section is found by algebraic summation of the circular shear produced by the applied torsional moment ($T/2A$) and the shear produced by direct loads. Direct shear is distributed according to VQ/I relationships. The effect of taper in relieving direct shear stress is recognized by the program. Shear flow varies across the panel elements; the shear flow magnitude at the center of the panel is used as representative for analysis purposes. (Panel elements are the member that connect the nodes and supply the structural material.)

Stresses in the longitudinal direction results from the application of bending moments and axial loads. The distribution of axial loads is proportional to the cross-sectional area. Stresses due to the application of bending moments are calculated under the assumption that plane areas remain plane after bending (Mc/I). Computations are made at each node. Stress level used for element analysis is the average value of stress for the nodes on either side of the panel.

A conservative estimate of rib load is made by assuming that the change in shear between stations is attributable to shear load applied to the intervening rib. This shear force is applied to the rib and reacted with a VQ/I shear flow distribution.

The distribution of material leads to the stiffness characteristics of the structure and to the distribution of internal loads. As the design is refined by the optimization process, changes occur in the amount and arrangement of the structural material. Consequently internal loads analysis is a required step in each design iteration.

2.4 MATERIALS

A library of materials is available to the program. Mechanical properties are given as a function of temperature for the aluminum alloys 2219-T87, 2024-T6, 2024-T851, 7075-T651; titanium alloys Ti-8Al-1Mo-1V, Ti-6Al-4V; Rene 41 and an arbitrary boron epoxy composite material (40% \pm 45°, 50% 0°, 10% 90°). An additional array is left vacant for temporary storage of a material not provided in the library. A linear interpolation scheme is used to estimate mechanical property values at the structural temperature of interest. A similar, although smaller, library of mechanical properties of honeycomb core is also provided. Aluminum cores range in density from 2.6 lb/cu. ft. to 8.1 lb/cu. ft.; steel cores from 4.5 lb/cu. ft. to 10.7 lb/cu. ft.

Material selection requires consideration of many design parameters. Examples of some parameters are ultimate strength, fatigue resistance, and fracture characteristics. Candidate materials may be compared by using a multiple run strategy.

2.5 COMPONENT ANALYSIS

This section describes the primary structural box components that are integrated to form a load carrying structure. Covers basically provide material to resist bending, spars to resist shear and ribs to stabilize the section and provide points for introduction of concentrated loads into the structural system. Each of these components may be fabricated by several construction methods. Method selection may be a function of geometric and mission parameters.

2.5.1 COVERS. Three general structural concepts for cover construction are considered:

Plate Stringer - Plate stringer construction is found on many aerospace structures. Skin panels are supported by closely spaced stiffening elements. These stiffeners may be a variety of shapes and may be integral with the skin or attached by mechanical means. Popular stringer shapes are blade, zee, tee, jay and hat. Ultimate strength of the composite plate stringer elements under combined compressive and shear loads is the usual criteria for margin of safety computation. Buckled skin and partially failed elements are not precluded by the analysis methodology. Stresses are also compared with ultimate material properties.

Multi-web - Multi-web construction is often used on high load factor aircraft such as military combat types. It permits concentration of the bending resistant material as close as possible to the external contour. The high loads felt by this type of structure lead to relatively thick skins.

Deflections that alter the section contour are aerodynamically undesirable and buckles in relatively heavy plate tend to precipitate cracks, therefore initial buckling in combined shear and compression is considered to be a mode of failure. Other failure modes are net stress in tension and compression. A minimum thickness cutoff is also tested.

Full Depth Sandwich - This method of construction is used on thin sections. Core weight is usually prohibitive if maximum section thickness is on the order of 4-5 inches. The skin is assumed to be fully stabilized and critical failure modes are based on net stresses in tension and compression with shear interaction. A minimum skin thickness may be specified.

2.5.2 SPAR CAPS. The majority of modern designs use a load carrying skin. Hence the significance of the spar cap in resisting bending loads is greatly reduced. Design requirements evolve to supporting the skin in crippling modes and providing shear continuity. The limits of ultimate mechanical properties must also be observed.

An exception to the above was a recently encountered hot structure where the bending material was concentrated in the spar caps while covers were relatively unconstrained to permit thermal growth. This case can be treated by the program. Caps compatible with built up, integral, truss and corrugated web type spar are analyzed.

The basic structural shape is a "T", for which minimum and maximum thickness and leg lengths must be input. (An angle can be represented by inputting zeros for thickness and length of an outstanding leg.) Thickness of the attaching web or skin

is also required (Figure 9). The size range is usually a function of manufacturing practicalities. Available mill sizes, minimum machinable gauge, minimum space for fastener attachment and handling requirements are typical examples of external constraints.

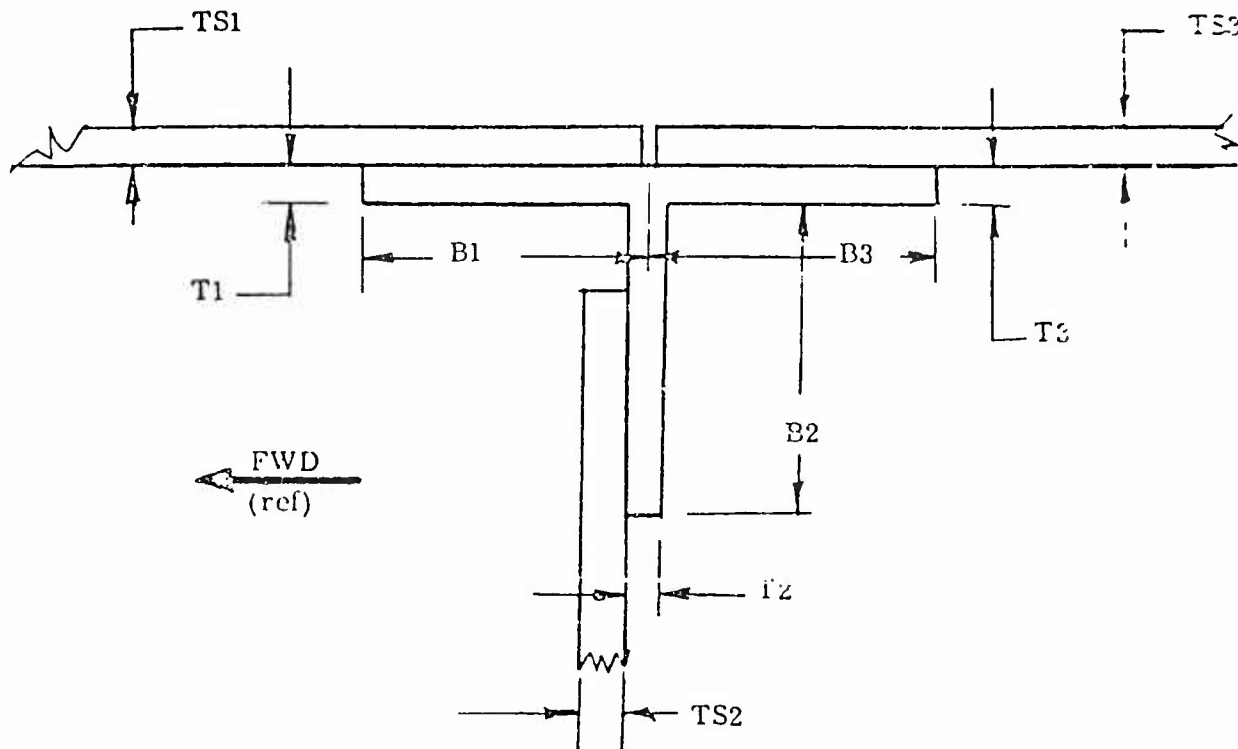

Figure 9. Typical Spar Cap Model - Built Up Web.

Failure modes considered are gross stresses in tension or compression, flange crippling and flange net shear. Column mode of failure must also be considered for the cap when truss type spars are used. It is conservatively assumed that for this case column length is equal to the rib pitch. Symmetrical sections must be used. Loads are transferred to the caps at discrete points, rather than continuously as with other designs; therefore, the local loading condition is a combination axial load and shear. Local shear flow is estimated to be 3 times the average shear flow for the bay. Either built up or integral truss type spars may be considered.

2.5.3 SPAR WEBS. Spar webs are the direct shear carrying components of structural boxes. They also contribute to the support of torsionally induced shears. The shear carrying capability may also be furnished by a diagonal member carrying tension or compression. The method of analysis and applicable failure modes are greatly influenced by the type of construction. Four distinct spar web types have

been identified and provided for.

Built Up Web Type - The spar web is assumed to have stiffeners on one side of the web. All stiffener legs are of equal thickness. Any cross section of four or less rectangular elements may be used (Figure 10). Web and stiffener must be of the same material. Presently provisions for 2024-T3 and 7075-T6 aluminum alloys are included. The method of analysis used is that given in Reference 2. Equations have been fitted to all pertinent curves. Spar web allowable stress is a function of the support offered by the surrounding structure and the material properties. Stiffeners are checked for column failure and forced crippling.

Integral Web - The integral stiffener analysis assumes a rectangular stiffener cross section with stiffener thickness equal to web thickness (Figure 11). An analysis routine was established based on the methods and curves of Reference 3. Best results are obtained with materials for which the ratio of F_{tu} / F_{su} is approximately 1.5. The allowable ultimate web stress may be either buckled or unbuckled depending upon the geometric and material property parameters.

Corrugated Web - The corrugated web consists of a series of circular segments joined in a continuous fashion to rigid caps (Figure 12). There are no theoretical material restrictions, however, it should be noted that the most practical methods of construction require some type of fusion process. Usually a weldable material is considered. Analysis methodology is given in Reference 4. Corrugated construction is considered to have failed when buckling either local or general occur. In addition, net shear stress is checked.

Truss - A truss arrangement can serve the same functional shear carrying role as a shear web. Application takes the form of diagonal axial members carrying either tension or compression (Figure 13). It is often difficult to insure that only tension will be felt by a particular member since at least partial load reversability is very common. Each member is analyzed for the maximum load in compression. Diagonal cross section may be cruciform, square solid, round solid, or tube. A representative truss angle may be input or a default value, one radian, used. Failure modes are column buckling for all shapes and also local crippling for the non-compact sections. This analysis is applicable to both integral and built up truss webs.

2.5.4 RIBS. The functional role of rib elements is dependent upon the structural concept being considered. In general ribs serve to help maintain section contour support air loads and redistribute shears and concentrated loads. The most significant factors on rib design are usually the redistribution of shears and the impact of concentrated loads.

Formed sheet metal ribs, corrugated ribs, ribs with built up or integral webs and built up or integral truss ribs are the structural types available in the rib library

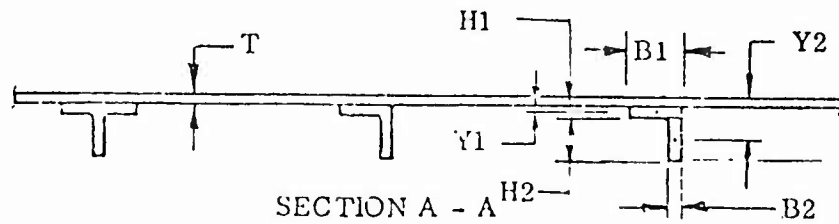
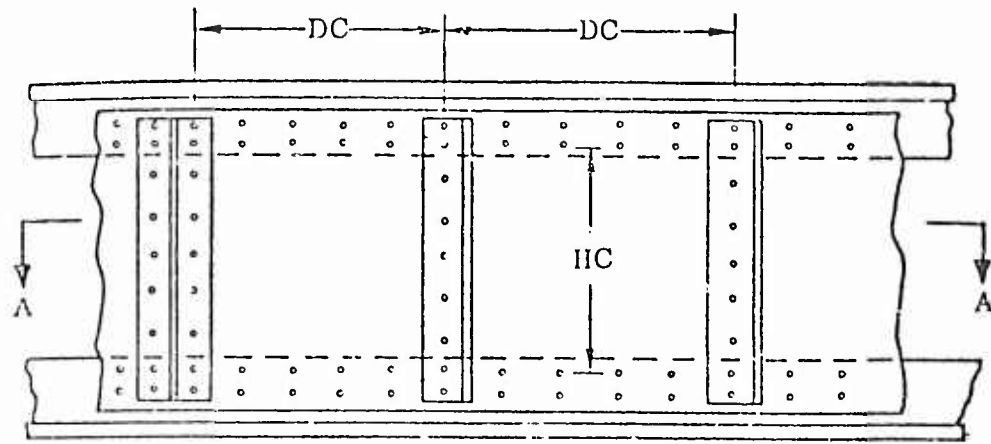

Figure 10. Built Up Web.

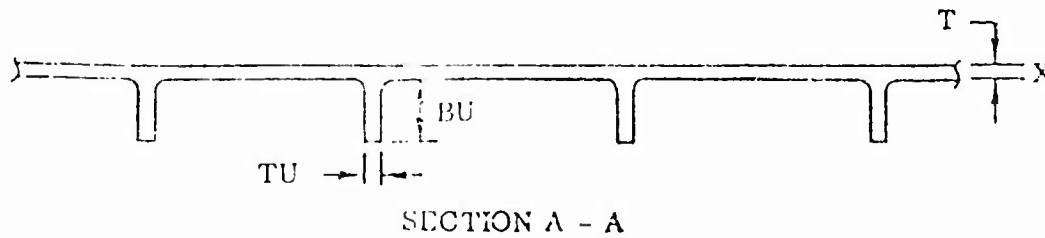
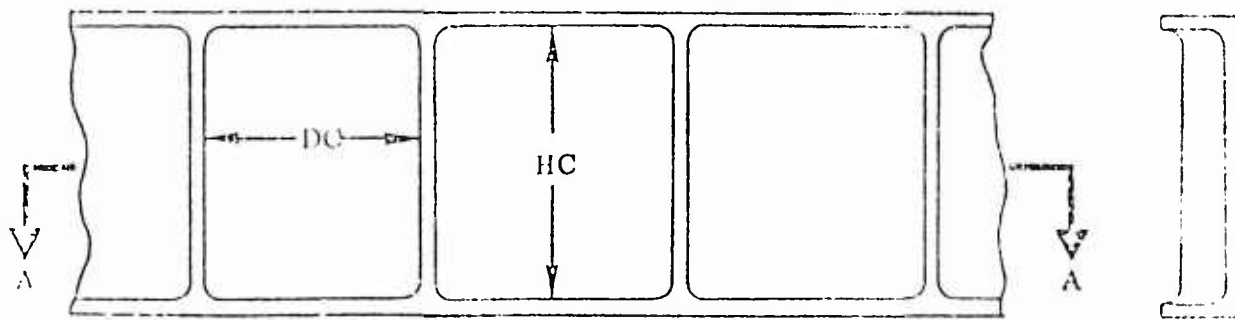
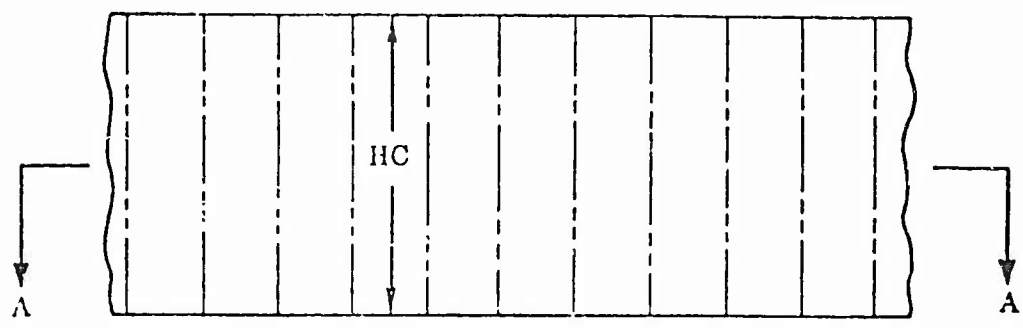
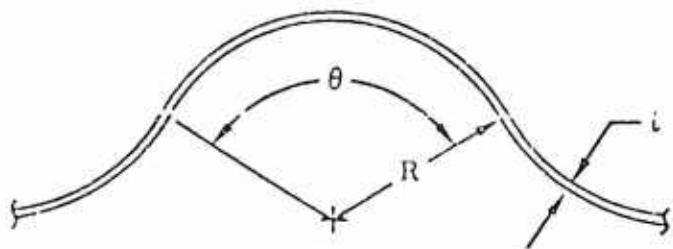

Figure 11. Integral Web.



SECTION A - A



VIEW B

Figure 12. Corrugated Web.

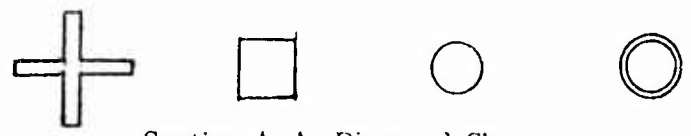
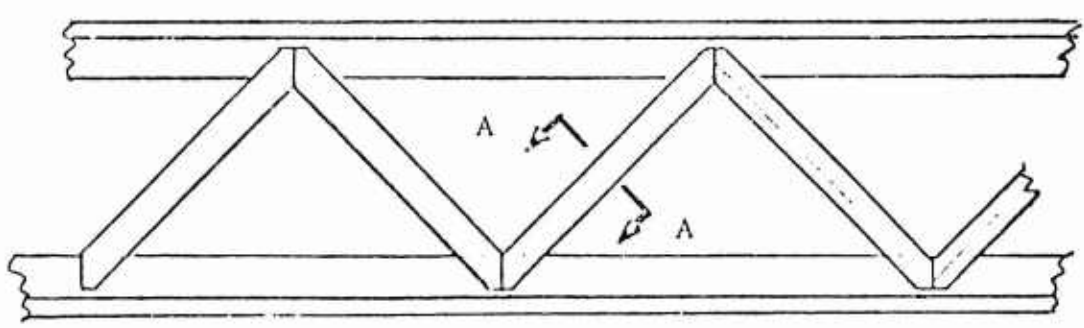

Section A-A Diagonal Shapes

Figure 13. Truss.

Figure 14). Rib web shears are determined by a VQ/I analysis where V is the span wise change in shear for one rib bay. The rib web is checked for the maximum shear flow at the station. When full depth sandwich construction is used the core material serves as a form of rib.

Formed Sheet Metal Rib - The formed sheet metal rib is assumed to be constant thickness including the rib flange or "cap". Failure modes for this rib are shear buckling, net shear stress exceeding material properties, crushing due to bending and shear in the flange.

Corrugated Rib - Corrugated ribs are formed by a continuous wave of circular segments. Web thickness is uniform. Rib caps offer continuous support. Net shear, shear-compression interactive buckling, minimum gage, and net shear through the flange are the modes of failure considered.

Built Up Web - The built up rib is very similar in construction to the built up spar. Analyses methods are also similar. Allowable stress in the web is a function of the support provided by the stiffeners and caps. A typical stiffener is checked for column failure and forced crippling.

Integral Web - The integral web rib is virtually identical to the integral web spar. Failure mode may be either buckled or unbuckled depending upon the fixity provided by the surrounding structure. The same analysis routines are used for both spar and rib webs.

Truss - Truss rib elements may be selected from a library of four simple shapes. Buckling and crippling failure modes are investigated for a typical element. A representative truss angle may be input or a default value of one radian will be used. Integral and built up truss ribs are treated identically by the program.

Core - Core material is available in discrete increments rather than the continuum of gages available to the other modes of construction. Analysis of the complex failure modes of sandwich core are foregone and load magnitude is used to select the proper core density.

2.6 FLIGHT SAFETY ANALYSIS

Fail safe, safe life and fatigue analysis are different methods of approaching the problem of structural reliability for the expected life and usage of the vehicle. The fail safe concept relies on redundancy of structure to support the required load after a critical member has failed. Presumably the vehicle will be able to complete its flight and the damage will be discovered and repaired. Damage could be the result of fatigue, or combat. Fail safe philosophy cannot be applied to all designs because redundant construction is not always feasible. Fatigue analysis estimates

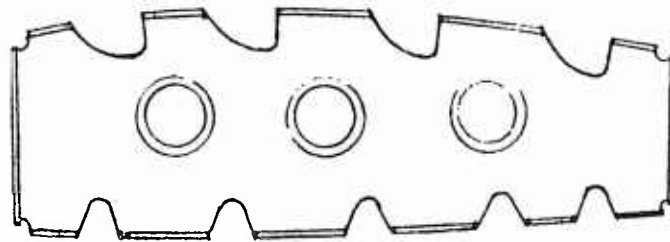

Formed Sheet

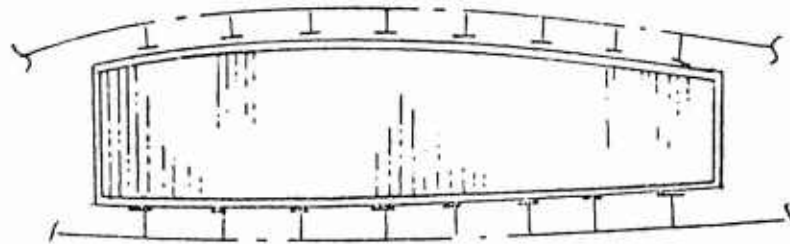

Corrugated Web

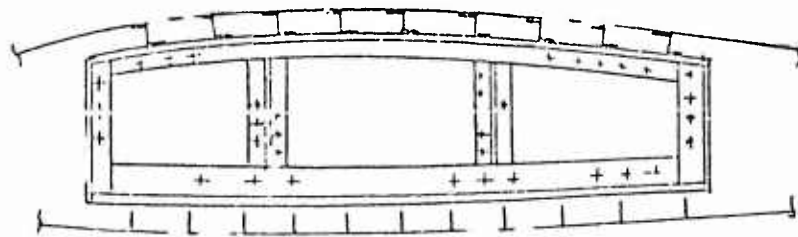

Built Up Web

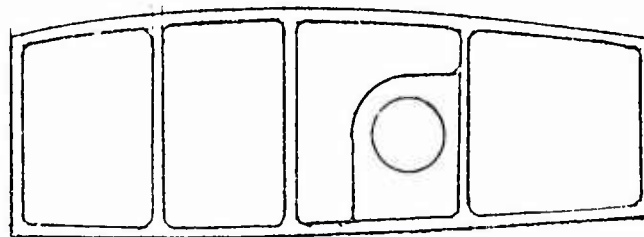

Integral Web

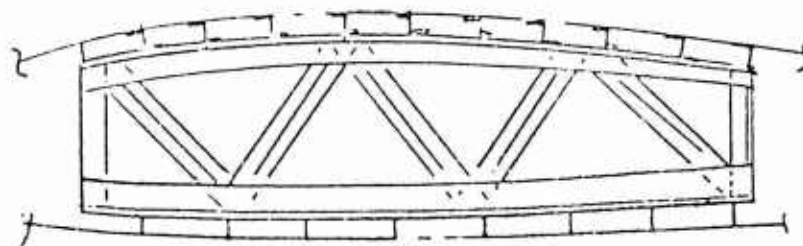

Truss

Figure 14. Rib Element.

the life of the structure under environmental conditions of temperature, local geometry (stress concentrations) and cyclic loading. The usual criteria examines the number of cycles or structural life until a crack appears. A fair amount of data in the form of S-N curves has been established on fatigue properties of various metallics. The safe life concept recognizes that flaws are inherent in virtually all metallic structures as a result of the manufacturing process. Flaws down to a certain size can be eliminated by inspection procedures or proof testing. The question is, what is the life of the structure, given an initial flaw size and the design spectrum of loads. Critical stress intensity factor (K_{IC}) and crack growth rate (da/dn) have been found to be significant parameters in determining safe life.

A scatter factor of from 2 to 4 is usually required on safe life and fatigue analysis. Safe life and fatigue analyses while serving the same general purpose are not mutually exclusive and are sometimes both requested by service agencies. For operation of this program it is anticipated that the user will specify the applicable type of analysis and provide the required inputs. Program output will be in the form of fail safe margins of safety for fail safe checks; and service or design life for fatigue and safe life analysis.

A reasonable indication of life and damage resistance can be obtained if the selected analysis is applied at two or three critical locations on the structure. For a wing or other lifting surface the tension skin at the root and one or two intermediate stations toward the tip are likely points of investigation. A pressurized structure should be checked at a location where bending and pressurization stress add.

2.6.1 SAFE LIFE. Safe life design requires sufficiently low design stresses that catastrophic failures of critical structural components will not occur during a specified service life due to the growth of flaws or defects pre-existent in the structure. The concept requires that the structure still support an appreciable load even if fairly long cracks are present and that cracks will be detected with 100 percent certainty before they can grow to a dangerous length.

Plain strain fracture toughness, K_{IC} is a key parameter in evaluating resistance to catastrophic failure. The stress intensity factor, K_I is compared to K_{IC} after completion of each block of cycles (representing on flight). Crack growth can be compared with inspection criteria.

Safe life is the life for initial defects to grow to a critical size for catastrophic failure. Typically the design requirements will be input as conditions - usually points of the flight envelope representing the corners of the V-N diagram plus a ground condition and possibly a few maneuver conditions.

As an illustration assume the following design conditions are applicable:

Condition 1	Maximum pull-up (N_z max.)
2	Buffet
3	Pushover
4	Rolling pullout (assymetric)
5	Taxi

Assume each flight may be characterized as:

20 cycles	100% of Cond. 1
40 cycles	1/ N_z max. Cond. 1
15 cycles	100% of Cond. 2
10 cycles	1.5/ N_z max. Cond. 1
10 cycles	50% Cond. 4
2 cycles	50% Cond. 3
20 cycles	100% Cond. 5

(This information will provide stress levels.)

A desired number of flights is also required and usually one of the specifications is 1000 flights. Initial flaw size will be an input and a function of the inspection or testing program. The flaw growth and stress intensity factor will be computed at the end of each flight. The allowable number of flights will be determined when the K_c is equal to K_c critical - or alternatively if the specified number of flights is reached before K_c exceeds K_c critical the design can be considered satisfactory.

One station at a time will be analyzed and the results will be informational, design is acceptable; or N flights can be completed before the stress intensity factor exceeds a critical value.

2.6.2 FAIL SAFE. Fail safe design requires that the failure of any single structural component will not degrade the strength or stiffness of the remainder of the structure to the extent that the vehicle cannot complete the mission at a specified percentage of limit loads.

Application of this philosophy leads to redundant designs offering many possible load paths. At preselected critical locations members are assumed to have failed and internal loads in the local structure are computed for fail safe applied load. Fail safe margins of safety may also be computed.

For commercial transport aircraft where safety is of utmost concern, fail safe capability is provided to the greatest possible extent. For military aircraft where performance is of primary concern, fail safe capability is not provided where weight penalties would result. Other methods described in the section, safe life and fatigue analysis, are relied upon to estimate flight safety in the case of military aircraft.

2.6.3 FATIGUE. Aircraft structural components loaded in tension are often designed to preclude fatigue failure. Components whose design allowables and weights are influenced by fatigue are lower wing skins and pressurized fuselages.

Fatigue analysis is a complex procedure that requires substantial amounts of data and criteria. It is generally performed at critical locations on the components of interest. To facilitate synthesis several simplifying assumptions based on design experience can be made to reduce the data required and the work involved to provide fatigue criteria. The fatigue requirements can be provided in summary form offering the comparison of design service life and stress level.

The methodology for development of curves portraying F_t/F_{tu} vs design service life is given in Reference 5. Results for several cases of interest are also presented. These cases are curved fitted and incorporated in a fatigue subroutine.

Fatigue life is the life an unflawed structural component to the initiation of visible fatigue cracks. It is synonymous with service life.

2.7 AEROELASTIC EFFECTS

Aeroelastic effects on the loads distribution have been included in previously prepared Convair programs (References 6 and 7) Use of these programs is recommended to generate the external load data. Other aeroelastic effects of interest are straight wing divergence and flutter and aileron reversal. The steps of the wing sizing procedure generate mass and stiffness data. This data is required to prepare the math model that is required for the aeroelastic analysis.

Results of this analysis will indicate divergence and aileron reversal speeds and frequencies of the first bending and torsional modes. These results may be compared with design criteria and previous experience with similar designs and a judgement as to acceptability may be made.

If the design is unacceptable corrective action is required. The appropriate action is seldom obvious. Many possible measures may offer solutions. Some possibilities are criteria revision, addition of damping systems, revision of structural arrangement, material change and redistribution of material. The weight and cost impact of these various approaches and the methodology to achieve them suggest complex questions that are best considered outside the synthesis loop.

Presently aeroelastic effects are studied in an external program. Driving inputs are supplied by synthesis and results are evaluated by disciplinary specialists.

2.8 WEIGHTS

Since all of the geometric information is available to the program, computation of volume and weight of the structural material, is a relatively simple step. This computed weight will account for only a fraction (historically approximately 1/2) of the actual finished weight. Items will exist in every structure that are insensitive to load or are impossible to identify for synthesis. Weight correlation factors are required to adjust the computed weight to a more represented value.

2.9 APAS PROGRAM INPUTS

The multi-station structural synthesis program performs analysis and redesign operations on one station at a time in a systematic fashion from root to tip. Each loading condition is processed and the full complement of structural elements at that station are satisfactorily optimized before subsequent stations are considered. Input requirements for program execution are identified by the set of input cards described below.

CARD No. 1 OUTPUT CONTROL CARD

Format (4I3)

KOUT1, KOUT2, KOUT3, KOUT4

Allows user to output various parts of the output to different output devices. A blank card defaults all output to device 6 (printer).

CARD No. 2 ITERATION AND TOLERANCE CONTROL CARD

Format (4 (I5, 5X), 4F10.)

IT1, IT2, IT3, IT4, EPS1, EPS2, EPS3, EPS4

Allows user to set limits on accuracy of solution and maximum passes through various iteration loops. A blank card defaults all terms to suggested values.

IT1 Iteration count limit on overall redesign/optimization procedure
 default value is (5).

IT2 Iteration count limit on fully stressed redesign process.

IT3 Iteration count limit on Fletcher Powell optimization procedure.

IT4 Not used.

EPS1 Tolerance on redesign margins of safety for each redesign cycle
 (Default value is .001)

EPS2 Tolerance on final margins on safety. At least one non-minimum gage element of each symmetry group for at least one load condition will have a margin of safety which satisfies

$$MS \leq EPS2$$

(Default value is .01).

EPS3 Tolerance on optimization function decrease in Fletcher Powell minimization technique.

(Default value is .001).

EPS4 Tolerance on design variable variation in Fletcher Powell minimization technique

(Default value is .001).

CARD No. 3 TITLE CARD (2 cards)

Format (8A10)

TITLE (I) I = 1, 16

CARD No. 4 CASE CONTROL CARD

Format (10I3)

KEY1, KEY2, KEY3, KEY4, KEY5, KEY6, KEY7, KEY8, KEY9, KEY10

KEY1 Allows user to select one of four geometry input subroutines

KEY1 = 1 specifies a general input subroutine "GINPT1" which is described below.

= 2 not currently available

= 3 not currently available

= 4 not currently available

KEY2 Allows user to select one of four external loads definition subroutines

KEY2 = 1 specifies a load input subroutine "LOADIN" described below by which the user inputs all loads.

KEY2 = 2 not currently available

= 3 not currently available

= 4 not currently available

KEY3 = 0 for fuselage type structures

= 1 for wing like structures

KEY4 Allows user to select how many locations along the structure he wishes to synthesize.

KEY4 = 1 synthesize at every rib/frame
= 2 synthesize at every other rib/frame
= 3 synthesize at every third rib/frame
etc.

KEY5 Not used

KEY6 Allows user to check input

KEY6 0 normal mode
1 check input and quit.

KEY7 Rib/Frame Type Specification

Rib (KEY3 = 1)

KEY7 = 1 corrugated web
= 2 integral web
= 3 built up web
= 4 integral truss
= 5 built up truss

Frame (KEY3 = 0) not currently available

KEY8 Unsupported panel width in terms of percent of panel element width.
Used for panel types 10, 11 and 12.

KEY9 Not used

KEY10 Not used

CARD No. 5 MATERIAL SPECIFICATION CARD

Format (I5, 5x, F10.0)

IMAT, FTEN

IMAT = 1 user supplied metallic material
2 AL-2219-T87
3 TI-8AL-1M0-1V
4 AL-2024-T6
5 AL-7075-T6
6 Inconel 718
7 Inconel 625
8 TI-6AL-4V
9 AL-2024-T851
10 Rene' 41

11 User supplied composite material

12 NARMCO 5505 Boron-Epoxy

13 NARMCO 5206 Graphite-Epoxy

FTEN Factor applied to ultimate tension allowable to
account for fatigue fracture mechanics, etc.

$$FT = FTEN * FTU$$

CARD No. 5A USER SUPPLIED METALLIC MATERIAL
PROPERTIES. (USED WHEN IMAT = 1)

This option allows the user to input a material not found in the material table above. The properties may be input as a function of temperature at nine specified temperatures.

5A1 Material title card
Format (8A10)

5A2 NTEMP
Format (I10)
NTEMP is the number temperature points specified.

5A3 Room temperature properties cards (2 cards)
Format (3F10.0, 2F20.0/F20.0, 3F10.0)
FTU FCY FSU EC E G RHO F07 EN

5A4 Temperature factors cards. (9 cards maximum)
Format 10F8.0)
TEMP, FFTU, FFCN, FFSU, FEC, FE, FG, FRHO,
FF07, FEN

CARD No. 5B USER SUPPLIED COMPOSITE MATERIAL PROPERTIES
(Used when IMAT= 11)

This option allows the user to input a composite material not found in the material table.

5B1 Material title card
Format (8A10)

5B2 Room temperature properties cards (2 cards)
Format (3F20.0, F10.0/6F10.0)
E11, E22, G12, U12, DEN, EPSAL1, 2, 3, 4, 5,

CARD No. 6 GEOMETRY CONTROL CARD
Format (4I3)
NODES, NWEFB, NLONG, NSTAG

NODES Number of node points in a cross-section (must be at least
 2 and may be maximum of 20)
 NWEB Number of interior webs (Max. of 3)
 NLONG Number of spar caps/longerons (Max. of 10) (must be
 located at nodal points)
 NSTAG Number of geometry control stations (Max. of 20)

CARD No. 7 GEOMETRY CONTROL STATION HEADER CARD

Format (6F10.0)

STAG, FRSP, XLDRF, ZLDRF, GTRX, GTRZ

STAG Station number of control station
 FRSP Rib/Frame Spacing
 XLDRF Coordinates of input loads
 ZLDRF Reference Point
 GTRX Taper ratio of structure
 GTRZ In the X and Z directions

CARD No. 8 GEOMETRY NODAL COORDINATE DECK

Format (I5, EX, 2F10.0) (1 card for each node)

NODE, X, Z

NODE Node number start with 1 and number consecutively
 around the structure clockwise.
 X
 Z Coordinates of node point

Repeat Cards 7 and 8 for each geometry control station.

CARD No. 9 INTERNAL WEB LOCATION CARD

Format (6I3) (Omit if NWEB is 0)

IW1, LW1, IW2, LW2, IW3, LW3.

IW1 Node number of first node to which an interior web is attached
 (Web No. 1)
 LW1 Node number at other end of web No. 1
 IW2 Same as above for next interior web.
 LW2

IW3
LW3 Same as above for last interior web.

CARD No. 10 SPARCAP/LONGERON NODE IDENTIFICATION
DECK

Format (4 (13, 2X, F10.0, 5X))

L1, DL1, L2, DL2, etc., four sets per card - one set for each longeron

Li Node number of spar cap/longeron i
DLi Orientation angle of spar cap/longeron

CARD No. 11 SYMMETRY GROUP CONTROL CARD

Format (3I3)

NSGP, NSGW, NSGL

NSGP Number of panel symmetry groups
NSGW Number of interior web symmetry groups
NSGL Number of sparcaps (Longeron) symmetry groups.

CARD No. 12 PANEL SYMMETRY GROUP IDENTIFICATION
DECK (1 card per symmetry group)

Format (24I3)

NMAX, NS(I) I=1, NMAX

NMAX Number of panels in this symmetry group
NS(1) Panel number of first panel in the symmetry group going
CW around the cross section.
NS(2) Panel number of next panel
Etc.

CARD No. 13 INTERIOR WEB SYMMETRY GROUP IDENTIFICATION
DECK (1 card per symmetry group)

Follow the same procedure as for panel symmetry group deck.

CARD No. 14 LONGERON (SPARCAP) SYMMETRY
GROUP IDENTIFICATION DECK.

Follow same procedure as for panel symmetry group deck.

CARD No. 15 STRUCTURAL ELEMENT CONFIGURATION SPECIFICATION
DECK

This deck defines the structural configuration desired for each panel, web, or longeron (spar cap). A deck is required for each symmetry group defined, an additional deck is required for each panel, web or longeron (spar cap) which does not belong to a symmetry group. The order of the decks is as follows:

PANELS

- (a) Symmetry group 1 thru NMAX
- (b) Panels which are not members of symmetry groups, starting with the lowest such panel number and going CW around the structure.

WEBS

Follow same procedure as for panels.

LONGERONS (Spar-Caps)

Follow same procedure as for panels.

CARD No. 15A TYPE IDENTIFICATION CARD

Format (2I3)

ITYP, IDSET

ITYP Structural configuration type number

IDSET (Optional) Each deck may be given an ID number which can be referred on other type identification cards which have identical structural element configuration specification decks. When referring to an ID number specified on a previous deck, cards 15b through 15f are omitted. (Note: Web Id's may not refer to panel ID's, etc.)

CARD No. 15b T SPECIFICATION CARD

Format (4F10.0)

T1, T2, T3, T4

Initial values for T variables.

CARD 15c TMIN SPECIFICATION CARD

Format (4F10.0)

TMIN1, TMIN2, TMIN3, TMIN4

Minimum values for T variables on card 15b. This card allows the user to specify minimum gages for the T variables. He may also fix a T variable at its initial value by setting its TMIN to 0. (Note: At least one T variable must have a non-zero TMIN.)

CARD 15d B VARIABLE SPECIFICATION CARD

Format (4F10.0)

B1, B2, B3, B4

Initial values for B variables

CARD 15e BMIN SPECIFICATION CARD

Format (4F10.0)

BMIN1, BMIN2, BMIN3, BMIN4

Minimum values for B variables. The user may fix any or all B values to their initial values by setting their respective BMIN values to zero.

CARD 15f BMAX SPECIFICATION CARD

Format (4F10.0)

BMAX1, BMAX2, BMAX3, BMAX4

Maximum limits for B variables. These values are ignored if corresponding B MIN values are zero.

CARD No. 16 INPUT LOADS CONTROL CARD

Format (I5, 5X, F10.0)

NCOND, FULT

NCOND Number of loading conditions (Maximum of 6).

FULT Ultimate factor of safety.

CARD No. 17 LOAD CONDITION HEADER CARD

Format (4A10, I5, 5X, F10.0)

Condition title, NSTAY, press condition title 40 characters

NSTAY Number of stations at which the load case is defined

PRESS Internal pressure used for fuselage structures.

CARD 17a LOAD COMPONENT FACTOR CARD

Format (8F10.0/F10.0) (2 cards)

(These factors applied to cards 17b)

FLIN	Factor applied to input stations to produce station numbers. (e. g. , input stations could be entered in percent fuselage length (wing span) and then FLIN would be actual fuselage length (wing span).
FLD	Factor applied to all input load components
FA	Factor applied to AXIAL loads
FXS	Factor applied to XSHEAR loads
FZS	Factor applied to ZSHEAR loads
FTOR	Factor applied to TORSION loads
FXM	Factor applied to XMOMENTS
FZM	Factor applied to ZMOMENTS
FTEMP	Factor applied to TEMPERATURE

Note: Factored load components are used by the program as
 limit design loads.

If cards 17a are blank, all factors are defaulted to 1.

CARD 17b LOAD POINT CARD

Format (8F10.0)

STA, AX, SX, ZS, TOR, XMOM, ZMOM, TEMP

STA	Station Number
AX	Station axial load
SX	Station X Shear force
ZS	Z SHEAR
TOR	Torque
XMOM	Bending moment about X axis
ZMOM	Bending moment about Z axis
TEMP	Structural temperature degrees Fahrenheit

SECTION III

SECONDARY STRUCTURE SYNTHESIS

This section presents a technical discussion associated with the initial development stage of a computer program for estimating the geometry, weights, part definition and primary cost drivers for aerodynamic surface leading edge, trailing edge and tip components. The aerodynamic surface structural box is not included as part of the program development. However, the output is designed to complement structural box analysis to provide complete coverage of the aerodynamic surfaces.

The discussion is presented in two sections. The first deals with the geometry and analysis of the leading edge, trailing edge and tip components and the second deals with the component part definition. The operation and output of the geometry, analysis and part definition program subroutines are designed for use in the conceptual and preliminary design phases of aircraft development.

3.1 TIP, LEADING AND TRAILING EDGE ANALYSIS

The leading edge, trailing edge, and tip synthesis modules provide the capability to analyze the aerodynamic surface structural components that are not considered as part of the structural box. The leading edge is defined as being forward of the front spar and includes the fixed portion of the leading edge and the leading edge high lift devices (slats). The trailing edge is defined as being aft of the rear spar and includes the fixed trailing edge, foreflaps, flaps, ailerons, rudder, elevator, and spoilers. The tip is defined as that structure outboard of the structural box tip closing rib.

The synthesis includes a definition of part geometry and a detailed stress analysis that determines gages, accounts for material types, and sets minimum gage constraints. The geometry routines provide dimensional input to the stress analysis routines. The geometry and stress routines output includes part size and weight, as well as parameters for the part definition. A generalized flow of the leading edge, trailing edge, and tip subprogram is shown in Figure 15.

The analysis utilizes eight geometry routines, three stress analysis routines, six supporting routines, and two calling routines. The geometry routines are for flaps aileron, rudder, elevator, slat location, slats, fixed leading edge, and spoilers.

The stress analysis routines include foreflap, spoiler, and one which analyzes the flaps, ailerons, slats, rudder, and elevator. The supporting routines derive dimensions, material properties, and general analysis. A discussion of these routines is included in the following paragraphs.

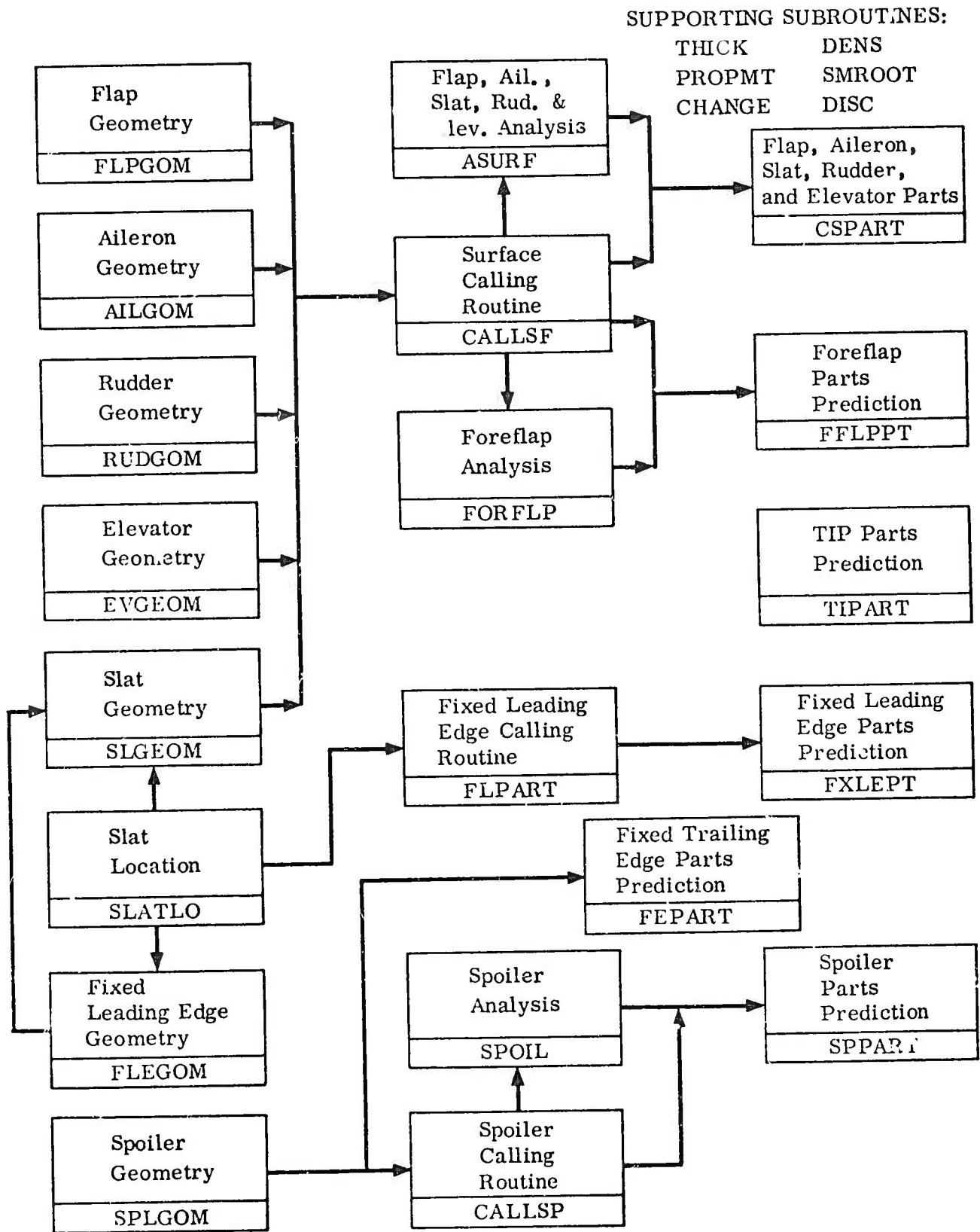

Figure 15. Leading Edge and Trailing Edge Synthesis Routines.

The flap geometry routine provides flap planform dimensions and locations from input data. The flap types considered are simple flaps, and single-slotted and double-slotted flaps. In the case of single or double slotted flaps the foreflap dimensions are computed in addition to the main flap dimensions. The driving parameters in determining flap dimensions are the flap area to wing area ratio, flap chord to wing chord ratio, and flap inboard chord. If the area ratio is input the flap length will be set to give required flap area. The flap length will be truncated at the wing tip or the inboard edge of the aileron. The flap chord is set by the ratio of flap chord to wing chord. If the ratio is zero the chord is assumed to be 85% of the distance aft of the rear spar. If the flap chord is input, the value of flap chord to wing chord ratio will be computed for use in determining flap dimensions. The inboard edge of the flap is located at the side of the fuselage. Flap geometry output consists of inboard and outboard chords, span stations of the flap inboard and outboard edges, and the flap length.

The aileron geometry routine provides aileron planform dimensions and locations from input data. The outboard edge of the aileron is assumed to be at the wing tip and the inboard edge is truncated at the side of the body if the inboard location is not specified. The aileron chord is computed as 10% greater than the trailing edge length. If the inboard edge location of the aileron is input the length will be set to provide the required aileron area. Aileron geometry output consists of inboard and outboard chords, span stations of the aileron inboard and outboard edges, and the aileron length.

The rudder geometry routine provides rudder planform dimensions and locations from input data. The rudder extends from the body to the vertical stabilizer tip. The rudder chord is set as 90% of the distance aft of the vertical stabilizer rear spar. Rudder geometry output consists of inboard and outboard chords, span stations of the rudder inboard and outboard edges, and the rudder length.

The elevator geometry routine provides elevator planform dimensions and locations from input data. The elevator extends from the body to the horizontal stabilizer tip. The elevator chord is set as 90% of the distance aft of the horizontal stabilizer rear spar. Elevator geometry output consists of inboard and outboard chords, span stations of the elevator inboard and outboard edges, and the elevator length.

The slat geometry routine comprises two separate operations. The first locates the inboard and outboard ends of the slats and defines the slat length. The inboard location is set at 1.5 ft. outboard of the side of the body. The outboard location includes 3.0 ft. of clearance for each wing mounted engine pylon. The second operation determines the individual slat lengths, chords, and inboard and outboard stations for two and four engine aircraft. The slat analysis for a two-engine configuration provides three options for slat segment location: 1) inboard only, 2) outboard only, 3) outboard only, 4) inboard and center, 5) center and outboard, and 6) inboard, center, and outboard. The specific slat chord lengths are computed as a function of the slat

chord to wing chord ratio. However, if the ratio is not input a value of 0.0735 is used. This is an average value for typical transport aircraft.

The fixed leading edge geometry routines provide planform dimensions and locations for the wing, horizontal stabilizer, and vertical stabilizer leading edges. The horizontal and vertical stabilizer leading edges start at the body and end at the tip. The leading edge chord is input as the total distance forward of the front spar. The wing has two types of fixed leading edges; under-slat and between-slat. The leading edges extend from the side of the body to the tip, the appropriate type being used as a function of the slat locations. The between-slat type extends the full distance forward of the front spar and the under-slat type assumes a chord equal to 8% of the wing chord. Fixed leading edge geometry output consists of the lengths and chords of each type of edge.

The spoiler geometry routine provides spoiler planform dimensions and locations from input data. If the spoiler area is input the spoiler will be sized to the area output from the aircraft sizing routine. If the area is not input the user must provide the inboard and outboard edge locations as well as the spoiler chord to wing chord ratio. If the spoiler chord to wing chord ratio is not input it is assumed to be 0.15. The spoiler inboard edge is assumed to be at the side of the body and the outboard edge is computed. The outboard edge is truncated at the wing tip or at the edge of the aileron. Spoiler geometry output consists of inboard and outboard chords, span stations of spoiler inboard and outboard edges, and the spoiler length.

The fixed trailing edge geometry routine assumes a total length from the body to the tip for wings, horizontal stabilizers, and vertical stabilizers. The fixed trailing edge chord is computed as a function of the total trailing edge length and the surfaces involved. The lower surface chord is computed as 6.8% of the trailing edge length if there are flaps and 10% if there are ailerons, rudders, or elevators. The upper surface chord is computed as 29.6% of the trailing edge length for flaps only. It is set equal to the spoiler chord if there are flaps and spoilers, and equal to 10% of the trailing edge length for ailerons, rudder, or elevators. If there are no control surfaces the fixed trailing edge extends from the rear spar to the aft edge of the wing, horizontal stabilizer, or vertical stabilizer.

The spoiler analysis produces structural member thicknesses and desired rivet patterns. The planform geometry is obtained from the spoiler geometry output. Member thicknesses are computed and adjusted to standard gages. Cross-sectional geometry is shown in Figure 16. The front spar is a bent-up sheet metal zee, the two ribs (at each support) are bent-up sheet, and the skins are sheet metal over a full depth honeycomb core.

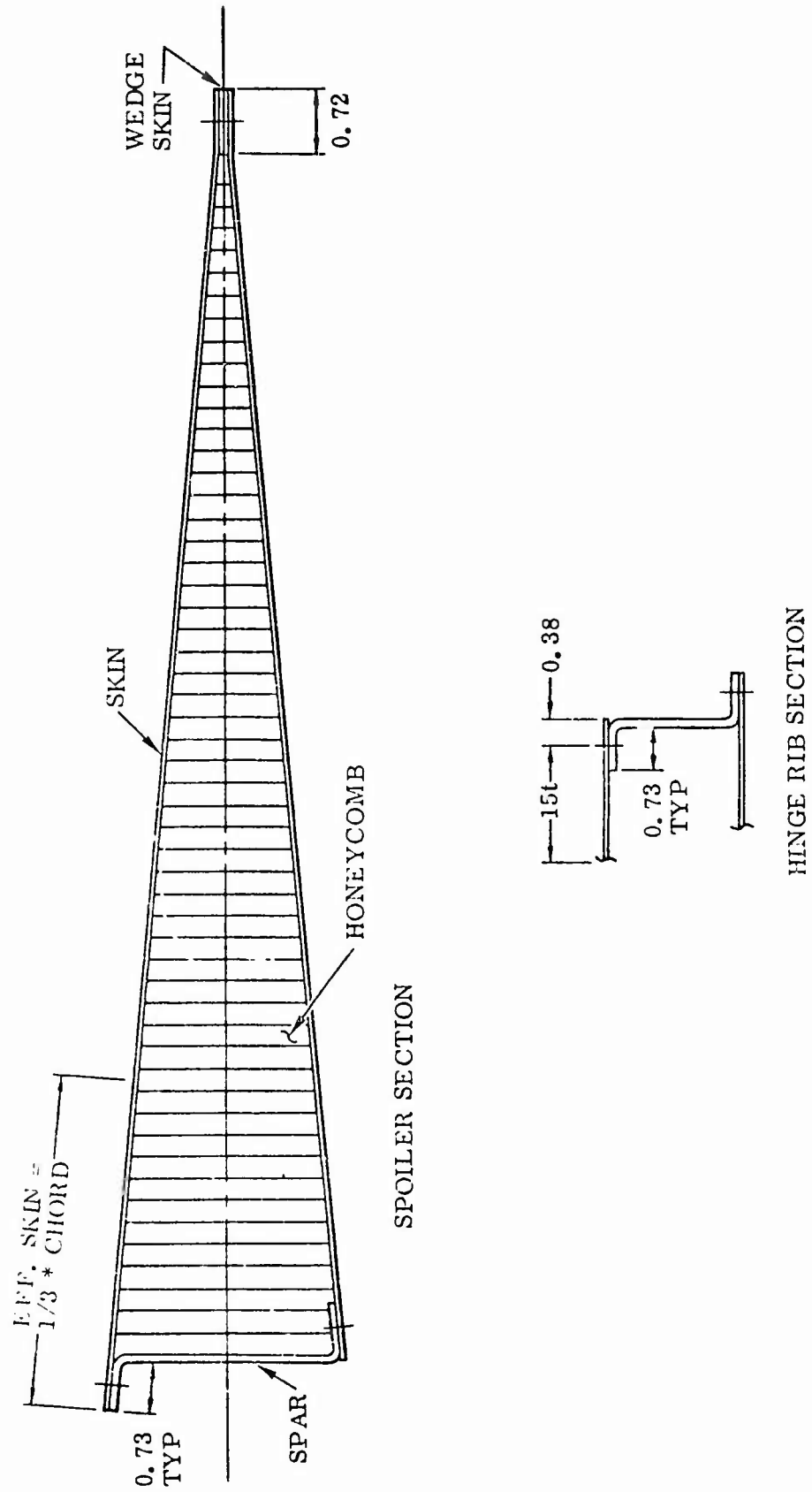

Figure 16. Spoiler Geometry

The spoiler analysis accounts for external and internal loads. The external loads for transport aircraft are normally those loads which the spoiler actuator produces. In this analysis the spoiler external load is assumed to be 600 lb - in. of hinge torque per running inch, limit. This is comparable to the Model 990 loading condition. The internal load analysis subdivides the total spoiler area into the smallest number of segments (individual surfaces) where all segments are equal in length and not longer than 60 inches. The segments are supported at each end and all torque is taken by the inboard support. The spoiler is analyzed as a simple beam. The point of maximum bending moment is determined, and the bending moment and spar depth computed. All spoiler bending moment is taken by the spar and effective skin. The bending section (Figure 16) is assumed symmetrical, and the tension and compression stresses are equal to:

$$F = \frac{M(d/2)}{I} \quad (1)$$

where

- F = bending stress
- d = contour depth at spar
- M = bending moment
- I = section moment of inertia

The compression buckling allowable is

$$F_{cs} = 0.56 F_{cy} \left[\left(\frac{2t^2}{A} \right) \left(\frac{E}{F_{cy}} \right)^{0.5} \right]^{0.85} \quad \text{(Reference 8, Eq. C7.4)} \quad (2)$$

where

- F_{cs} = compression buckling allowable
- F_{cy} = compressive yield allowable
- t = material thickness
- A = cap area (= 1.73t)
- E = material elastic modulus

The spar cap sheet thickness is sized so that the stress level is equal to or less than the larger of the compression buckling allowable or 80% of the ultimate tensile allowable.

The inboard rib is analyzed for bending at the front spar. Since all torque is taken at this rib, the bending moment is equal to the total spoiler torque about the spar. The

section (Figure 16) is symmetrical and the tension, compression, and compression buckling stresses are computed the same as shown for the spar.

The skin thickness is based on skin shear flow at the inboard hinge where all spoiler torque is reacted about the spar. Since the skin is supported by the honeycomb core, the shear allowable is based on the ultimate shear stress times a rivet factor of 0.8.

Appropriate material properties are selected for each part analyzed. The analysis determines the material thicknesses as a minimum required thicknesses and then rounds the value of the next larger standard gage. A minimum gage of 0.020 in. and a maximum gage of 0.250 in. are set as constraints. The standard sheet gages used are summarized in Table 1.

Table 1. Standard Sheet Gages

in.	in.
0.020†	0.071
0.025	0.080
0.032	0.090
0.036	0.100
0.040	0.125
0.045	0.160
0.050	0.190
0.063	0.250#

† Minimum # Maximum

The number of rivet holes (representing the actual number of rivets needed) and the hole sizes are output. The quantity and size of the rivets is based on a T/2A shear flow analysis at the inboard rib. The rivets are sized based on the protruding head shear allowables at a spacing of four times the shank diameter. The number of holes is equal to the number of rivets. That is, the holes are counted for only one member. When two rows of rivets are required, an additional amount of spar or rib cap width is output, but the additional area is not used to resize the cap.

The foreflap analysis produces the structural member dimensions and desired rivet patterns. The planform geometry is obtained from the foreflap geometry output. Member thicknesses are computed and then adjusted to standard gages. A typical foreflap cross section is shown in Figure 17. The front spar is bent-up sheet metal channel and is sized by a loads analysis. The leading edge skin and rib thicknesses are fixed at 0.050 in. The honeycomb box factor is set at 1 and assumes an allowable shear stress of 160 psi. The box skin thickness is assumed to be 0.020 in.

The foreflap spar analysis accounts for external and internal loads. The external applied loads are derived from the general formula:

$$W = S C_n \left(\frac{V^2}{295} \right) \quad (3)$$

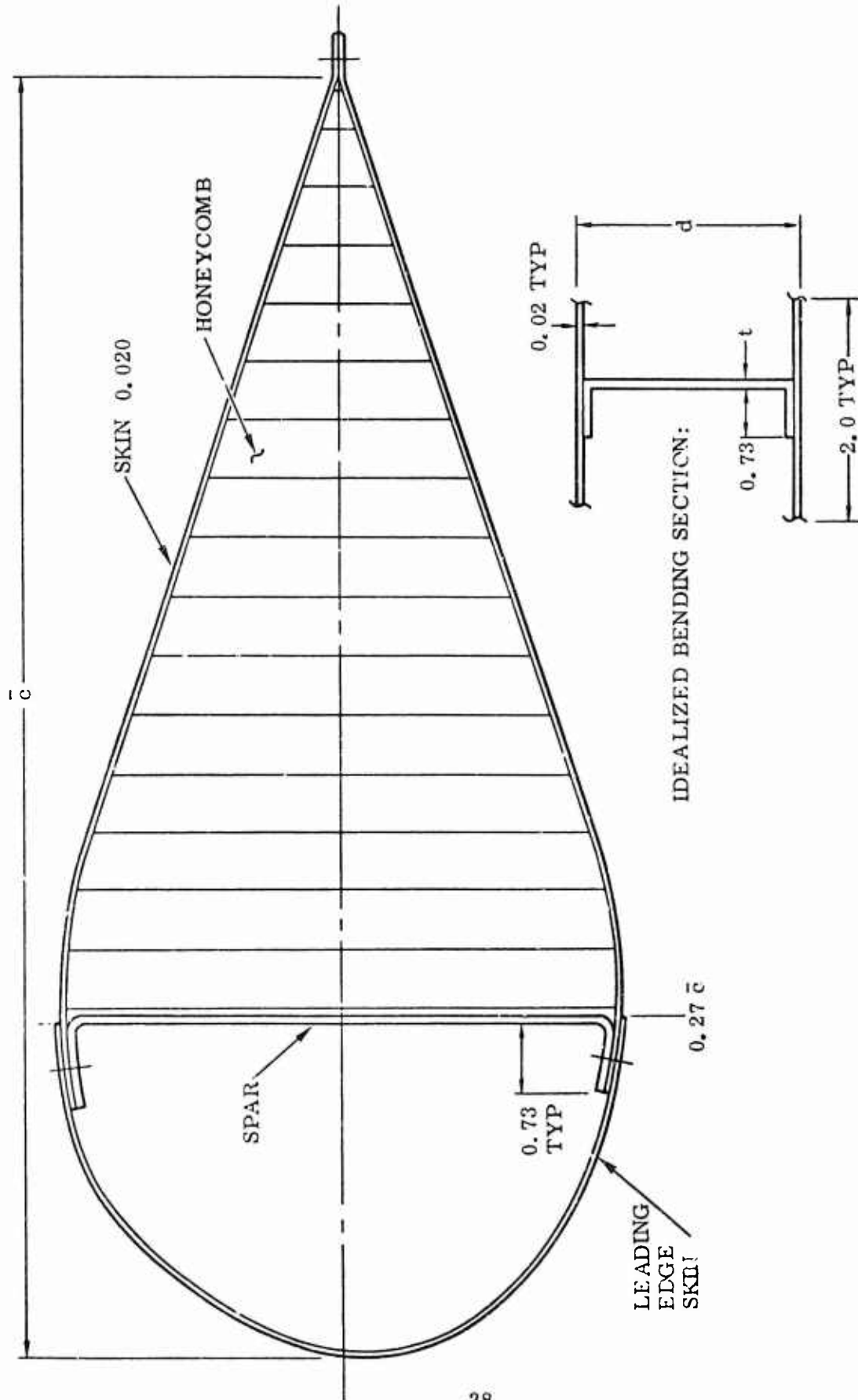

Figure 17. Foreflap Geometry.

where

- W = total surface load
- S = total surface area
- C_n = normal lift coefficient
- V = design speed

The average pressure, ultimate, is applied to the foreflap uniformly and is computed from the transposed form:

$$P_{ave} = \frac{W}{S} = 1.5 \left(\frac{C_n V^2}{295} \right) \quad (4)$$

where

- P_{ave} = average ultimate surface pressure and for the foreflap
- C_n = 4.0
- V = 1.75 V_s, where V_s = stall speed

The internal load analysis subdivides the total surface length into a number of equal length segments (individual surfaces) each with a length equal to or less than 180 in. If the individual segment length turns out to be greater than 140 in., three hinge supports are assumed. One is in the center and two are located 15% of the surface length from each end. If the individual surface length is less than or equal to 140 in., two hinge supports are assumed, each 28% of the surface length from each end.

The vertical shear, bending moment, and torque about the front spar are calculated at each hinge. The torque is calculated at each end of the surface segment and is assumed to vary linearly between the ends. The torque is reacted at each hinge using the same formulae used to calculate shear reactions. The foreflap bending is assumed to be taken by the spar and associated skin as shown in Figure 17. The bending stress can be computed from Equation 1, and the compression buckling allowable stress can be computed from Equation 2. Spar thickness is sized to be the minimum necessary so that the stress level is equal to or less than the larger of the compression buckling allowable or 80% of the ultimate tensile allowable.

All rivet patterns are assumed to be comprised of a single row of 0.25 in. diameter rivets spaced at two diameters. The output number of holes is equal to the number of rivets. However, each rivet is accounted for in only one part of the joint. Adjustment of material thicknesses to a standard gage is accomplished in the same manner as discussed for the spoiler.

The analysis of the flaps, ailerons, slats, rudder, and elevators produces the structural member dimensions and the desired rivet patterns. The planform geometry is obtained from the specific control surface geometry output, and the member thicknesses are computed and then adjusted to standard gages. The control surfaces are assumed to have the geometry shown in Figure 18. The front spar has extended caps and a sheet metal web, and the rear spar is a bent-up sheet. Both the leading edge skin and the main box skin are sheet metal. The trailing edge consists of a full-depth honeycomb core with a single piece of sheet metal forming both upper and lower skins. The airload ribs and the leading edge ribs are bent-up metal. There is a leading edge rib at each airload rib span station. The hinge ribs consist of extruded spar caps and a sheet metal web with bent-up flanges to pick up front and rear spars.

Appropriate material properties are selected for the analysis of each part. Thicknesses are fixed for the leading edge skin and ribs, airload ribs, rear spar, and trailing edge skin as follows:

<u>Part</u>	<u>Thickness</u>
Leading edge skin	Same as box skin
Leading edge ribs	Same as airload ribs
Airload ribs	One gage heavier than skin
Rear spar	One gage heavier than skin
Trailing edge skin	Minimum gage

The analysis for the remaining parts determines the material thicknesses in terms of a minimum required thickness and then rounds the value to the next larger standard gage. Standard sheet gages are summarized in Table 1, and standard gages for extrusions in Table 2.

Table 2. Standard Extrusion Gages

in.	in.
0.050 †	0.125
0.063	0.156
0.078	0.188
0.094	0.250 #

† Minimum # Maximum

The parts sized by a loads analysis include the basic skins, spar webs, spar caps, hinge rib caps, hinge rib webs, and the trailing edge honeycomb. The analysis accounts for both the internal and external loading conditions. The applied external loads are normal (to the surface) loads

only. For the wing surfaces (flaps, ailerons, and slats) these normal loads are derived from the general formulae of Equations 3 and 4.

For flaps,

$$V = 1.75 V_s \text{ (Ref. MIL-8860, Para. 6.2.3.9), where } V_s = \text{stall speed}$$

$$C_n = 1.6$$

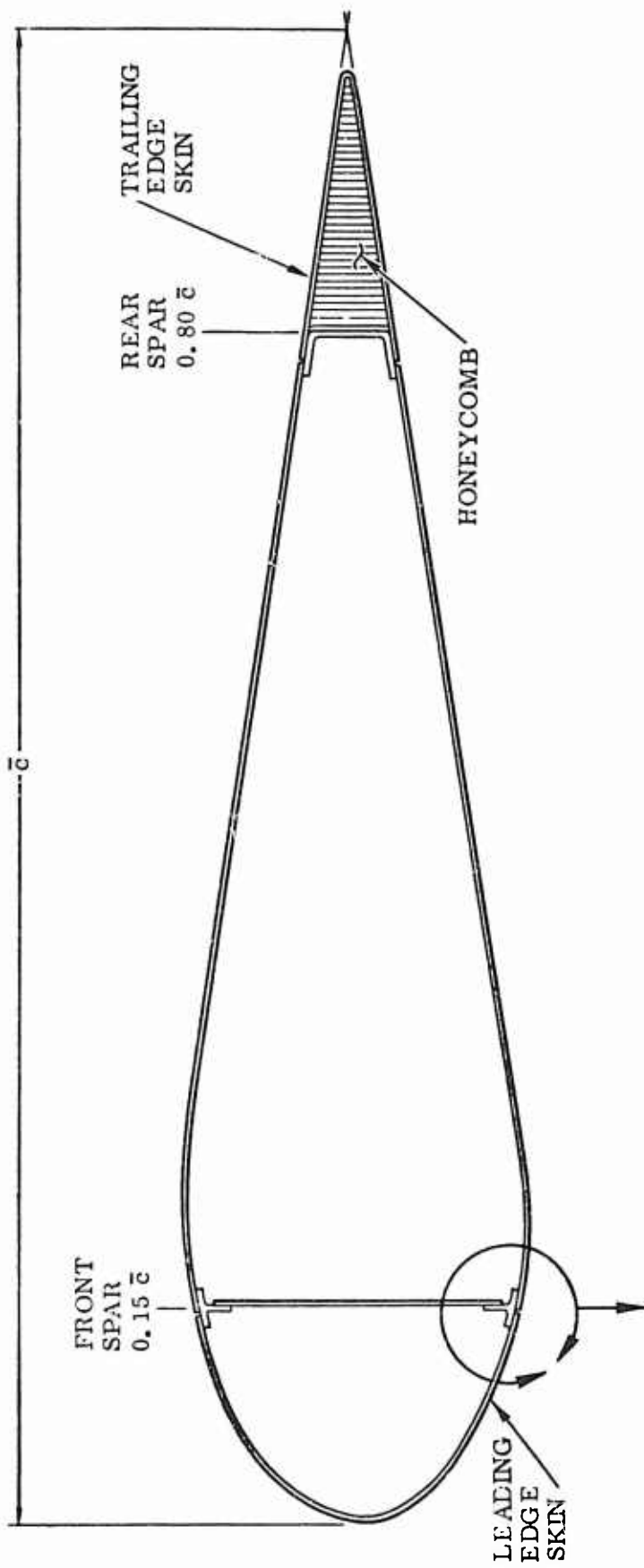

ED = 0.38

EFF. SKIN & WEB = 0.38 + 15t

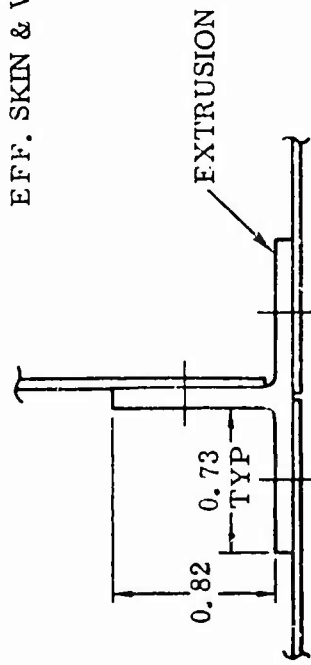

Figure 18. Typical Geometry for the Flaps, Slats, Ailerons, Rudder, and Elevators

For slats,

$$V = 1.75 V_s$$

$$C_n = 3.0$$

For ailerons, rudders, and elevators, V is derived from

$$N_z W = C_{L_{Max}} S_{Wing} \frac{V^2}{295} \quad (\text{MIL-8860, Para. 3.2.2.2});$$

or transposing:

$$V_a = V = \frac{295 N_z W}{C_{L_{Max}} S_{Wing}}$$

where

N_z = maximum normal load factor

W = aircraft gross weight

$C_{L_{Max}}$ = maximum lift coefficient

S_{Wing} = wing area

V_a = aileron design speed

For ailerons,

$$C_n = 1.6$$

For rudders and elevators,

$$C_n = 1.3$$

The average pressure, P_{ave} , is applied to the control surface as a chordwise triangular distribution with the center of pressure at the 33% chord aft of the leading edge. If the design speed is equal to or greater than Mach 1, the center of pressure for the aileron, rudder, or elevator is assumed to be at the 47% surface chord. Spanwise running surface loads are therefore proportional to surface chord.

The internal load analysis subdivides the total surface length into a number of equal length segments (individual surfaces) each with a length equal to or less than 180 in.

If the individual segment length is 140 in. or less, two hinge supports are assumed, located 28% of the total length from each end. If the segments are greater than 140 in. , three hinge supports are assumed. One is located in the center and two are located 15% of the total length from each end. The vertical shear, bending moment, and torque about the front spar are calculated at each hinge. Torque is calculated at each end of the surface segment and is assumed to vary linearly between the ends. For flaps and slats, torque is reacted at each hinge using the same formulae used to calculate shear reactions. For ailerons, rudders, and elevators all torque is reacted at the inboard (or lower) hinge.

The skin thickness is computed based on skin shear flow, and the allowable stresses are fixed as a function of rib spacing. Since the hinge rib number and locations are fixed, rib spacing is determined for each bay between hinge ribs by equally spacing airload ribs. For a given skin thickness, rib spacing can be determined from Figure 19. This curve is a typical design curve for sonic fatigue requirements as discussed in Lockheed Design Handbook, pages 10.801 - 10.809) and Lockheed Report LG1538-3-1, Figure 5.3.

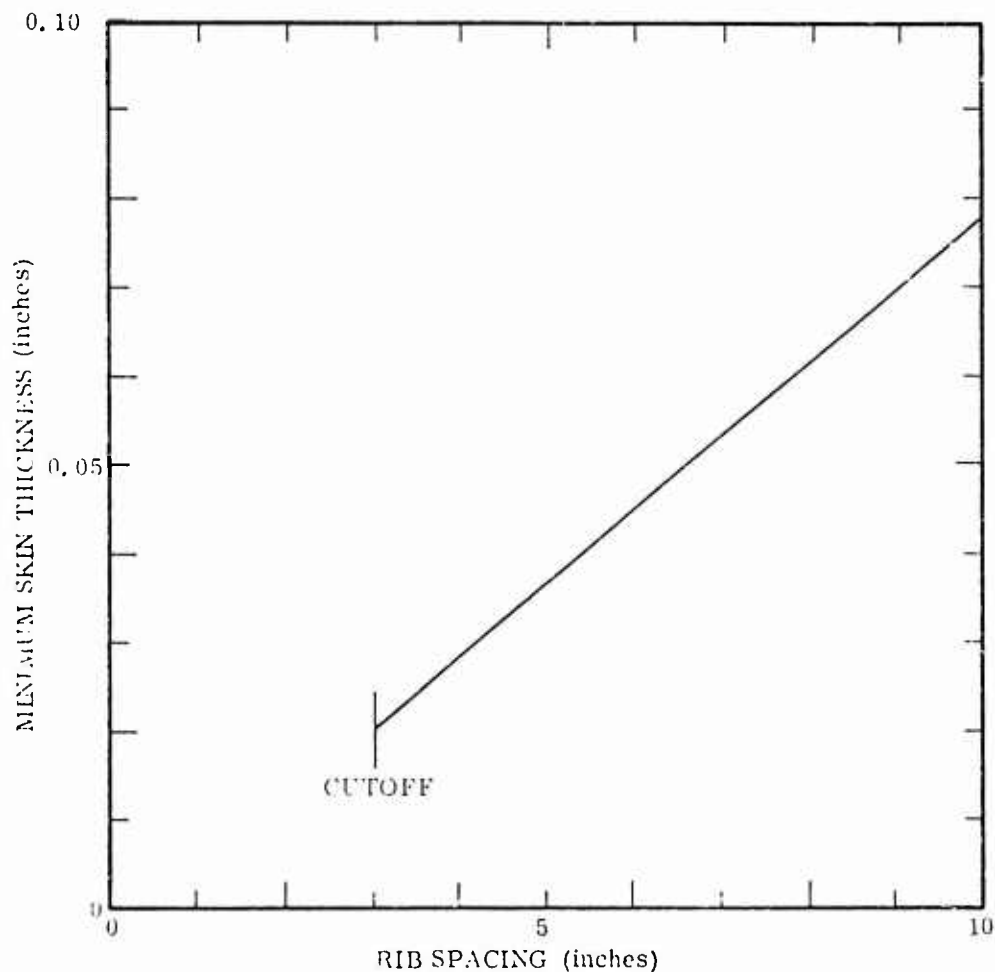

Figure 19. Sonic Fatigue Curve.

For practical considerations, a minimum rib spacing of 3.0 in. is used.

An analysis is made of the inboard panel of the bay with the maximum rib spacing assuming maximum skin shear flow exists there. Allowables are determined for an incomplete-diagonal-tension panel utilizing NACA TN 2661. The critical buckling stress is computed from $F_{S_{CR}} = K_{ss} E (t/d)^2$ where K_{ss} is from Figure 12 of

Reference 2. The diagonal tension factor, K , is derived from Equation 27 of Reference 2. Then the allowable shear stress can be determined as a function of K utilizing the 40-degree curve of Figure 19 (a) of Reference 2. The skin is sized so that the maximum shear stress does not exceed the allowable, and so that the ratio of the maximum to the critical shear stress does not exceed 5.

The spar web thickness is determined using the maximum spar shear flow. The analysis is made using either the panel at the inboard end of the surface segment or the panel just outboard of the inboard hinge, whichever has the greatest ratio of spar height to rib spacing. An incomplete diagonal-tension analysis is made like that made for the skin.

All flap bending moment is taken by the front spar caps and associated skin and spar web. The critical bending location is at the hinge where the ratio of bending moment-to-spar depth is largest. The effective spar section is as shown in Figure 18.

This bending section is symmetric; therefore, tension and compression stresses are equal and may be computed from Equation 1.

$$F = \frac{M(d/2)}{I}$$

d = contour depth at spar

The compression buckling allowable,

$$F_{cs} = 0.67 F_{cy} \left[\left(\frac{3t^2}{A} \right) \left(\frac{E}{F_{cy}} \right)^{0.5} \right]^{0.40} \quad (\text{Reference 8, Equation C7.5})$$

where

F_{cs} = compression buckling allowable

F_{cy} = compressive yield allowable

t = material thickness

$A = \text{cap area} (= 1.46 t^2 + 0.82t)$

$E = \text{material elastic modulus}$

The spar cap is assumed to be an extrusion with a constant section thickness sized so that the stress level is equal to or less than the larger of the compression buckling allowable or 80% of the ultimate tensile allowable.

For all surface types, hinge ribs are assumed to have the same part thickness as the inboard hinge. The rib cap is sized by the rib bending moment at the front spar which is equal to the surface torque (about front spar) at the inboard hinge. The generalized effective rib section is considered to be the same as the spar section. The compression buckling allowable stress equation is the same as that used for the spar. The rib cap is assumed to be an extrusion, and the constant section thickness is sized in the same manner as the spar cap. The web thickness is sized to be adequate for the inboard hinge rib shear flow,

$$Q = \frac{T}{2A}$$

where

$Q = \text{inboard hinge shear flow}$

$T = \text{torque reacted by the inboard hinge}$

$A = \text{inter-spar box area at the inboard hinge}$

The shear buckling stress is calculated for a web panel at the front spar assuming a panel aspect ratio of 2.

$$F_{SCR} = 5.9 E \left(\frac{t}{h/2} \right)^2$$

where

$F_{SCR} = \text{shear buckling stress}$

$E = \text{material elastic modulus}$

$t = \text{material thickness}$

$h = \text{front spar height at rib}$

The web thickness is sized so that the shear stress level is equal to or less than the larger of the shear buckling stress or 80% of the ultimate shear allowable.

The assumed honeycomb type and size has a shear allowable of 160 lb/in². A factor is developed that indicates how much heavier than the basic core the actual core must be. The factor, K_{core} , is based on the core shear due to trailing edge air-load.

$$f_s = \frac{(0.2 P_{\max}) (0.2 \text{ chord})}{2d}$$

where

f_s = core shear

P_{\max} = maximum airload

chord = chord length

d = contour height at rear spar

and

$$K_{\text{core}} = F_s / 160$$

Rivet sizes and numbers are calculated using the shear flows that sized the skin, spar web, and hinge rib web. Rivet shear values are used as the allowables and a rivet spacing of four diameters is assumed.

<u>Q (lb/in)</u>	No. of <u>Rows</u>	<u>Rivet</u>	Spacing <u>in.</u>
0 to 776	1	4AD	0.50
777 to 954	1	5AD	0.625
955 to 1573	1	6DD	0.75
1574 to 1957	2	5DD	0.625
1908 and above	2	6DD	0.75

In the output the number of holes is equal to the number of rivets; each rivet hole is accounted for in only one part of the joint. When two rows of rivets are required, an additional spar or rib cap width is output. This additional area is not used to re-size the cap.

3.2 TIP, LEADING AND TRAILING EDGE PART DEFINITION

The tip, leading edge, and trailing edge part definition routines define the detail parts making up the fixed leading edge, fixed trailing edge, slats, flaps, foreflaps, control surfaces (spoilers, ailerons, rudder, and elevators), and tips. The data that is generated includes the number of parts, part dimensions, weight, and cost parameters. The parts definition derives its input from previous geometry and analysis subroutines.

The fixed leading edge segments, as defined by the geometry subprogram, are divided into a number of 60-in. sections with one shorter section. If the segment is 60 in. or less, only one section is assumed. The under-slat leading edge is made of two skins spliced at the nose with an extruded angle (chafing strip). The between-slat leading edge has a one piece skin; the skin perimeter is assumed equal to 2.5 times the fixed leading edge chord. The upper skin of the under-slat segment utilizes a factor of 1.5 and the lower skin a factor of 1.0. The skin thickness is set at 0.040 in. with the chafing strips and edge member thicknesses set at 0.060 in. The ribs are spaced at 10-in. increments, and the rib height is assumed to be 0.85 times the rib chord length. The ribs are made of bent-up 0.040-in sheet with lightening holes. The rib-to-skin fasteners are 5/32-in. diameter rivets spaced at 0.75-in intervals. The chafing strip rivets are 5/32 in. in diameter spaced at 0.625-in. intervals, and the edge member-to-skin rivets are 3/16 in. in diameter spaced at 1.5 in.

The fixed trailing edges for the wings, horizontal stabilizer, and vertical stabilizer, illustrated in Figure 20, are assumed to be comprised of flat sheet skins and bent-up sheet ribs. All skins are 0.037-in. thick and, like the fixed leading edge, are defined in terms of 60-in. segments. The ribs are spaced at 10-in. increments and are constructed of bent-up 0.040-in. sheet with a 0.73-in. flange on each edge. Lightening holes are spaced at 1.5-in. intervals and have a diameter of 0.375 times the local chord. The skins attach along the forward edge and along each rib with 5/32-in. diameter rivets spaced at four diameters.

The spoiler, illustrated in Figure 16, is assumed to be comprised of a spar, skins, honeycomb core, and a wedge shaped skin closure. The parts definition process defines the dimensions, and the rivet sizes and quantities based on the spoiler stress analysis. The material weight assumes 1.0 in. added to the length and width dimensions of the sheet flat pattern, and to all dimensions of the full-depth honeycomb core. The material weight of the core includes 0.1 lb/ft² for adhesive.

The parts definition for the foreflap (Figure 17) derives the dimensions, and the rivet sizes and quantities from the foreflap stress analysis. The upper, lower, and leading edge skins have material weights calculated assuming 1.0 in. of additional material on all sides. The leading edge skin width, or cross-section periphery, is set equal to 2.64 times leading edge chord. Foreflap cross-sectional area aft of the spar is calculated as

$$\text{Area} = (\text{spar height}) \cdot (\text{chord length aft of spar}) \cdot 0.698$$

This formula provides the basis for computing the honeycomb core and closing rib weights. Material weight for the core is based on maximum dimensions plus 1.0 in. Closing rib material weight is based on flat pattern dimensions plus 1.0 in. on each side.

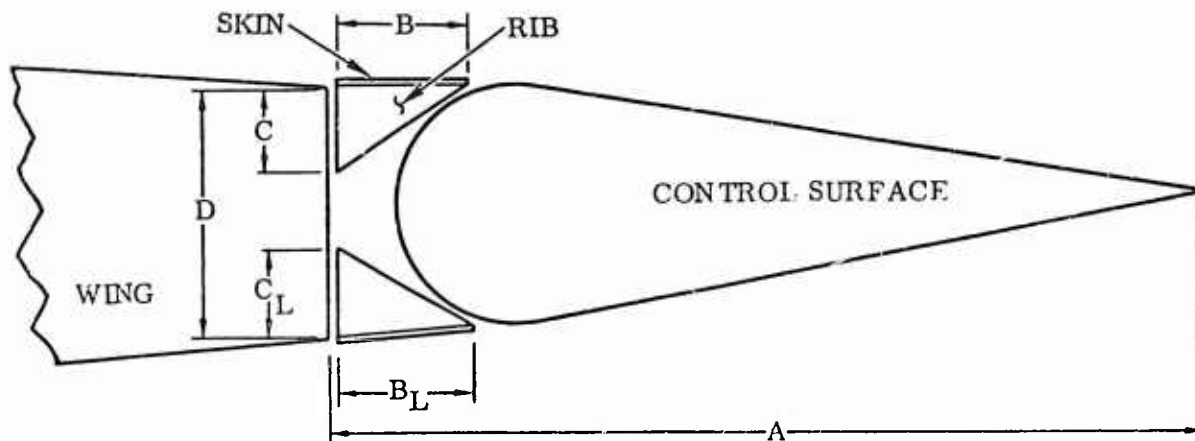

$D = 0.85$ (MAX. WING THICKNESS)

$C =$ LESSOR OF B OR $D/2$

$C_L =$ LESSOR OF B OR $D/2$

LOCATION	B	B_L
AT FLAP (NO SPOILER)	$0.296A$	$0.068A$
AT FLAP (INBD./OUTBD. OF SPOILER)	SPOILER CHORD	$0.068A$
AT AILERON	$0.10A$	$0.10A$
AT RUDDER/ELEVATOR	$0.10A$	$0.10A$

INBOARD OF AILERON (NO FLAP)

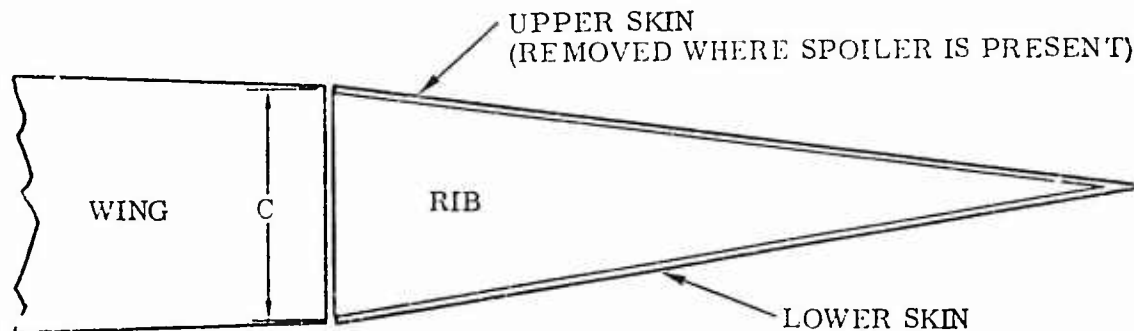

Figure 20 Fixed Trailing Edge.

The parts definition process for the flaps, ailerons, rudders, elevators, and slats (Figure 18) derives the dimensions, and rivet sizes and quantities from the control surface stress analysis. The surface skins are assumed to be made in three pieces. The inboard and outboard skins are assumed to have a length equal to 28% of the surface length and the center 44% of the surface length. The leading edge skin width (periphery of leading edge cross section) is calculated from the following:

$$\text{Inboard skin width, INSWI} = K \left[\frac{2 (\text{DCSWI}) - .28 (\text{DCSWI} - \text{DCSWO})}{2} \right] \quad (.15)$$

$$\text{Center skin width, DNSWC} = K \left[\frac{2 (\text{DCSWI}) - (\text{DCSWI} - \text{DCSWO})}{2} \right] \quad (.15)$$

$$\text{Outboard skin width, DNSWO} = K \left[\frac{\text{DCSWO} + \text{DCSWI} - .72 (\text{DCSWI} - \text{DCSWO})}{2} \right] \quad (.15)$$

where

K = 2.98 for slats

= 2.57 for other surfaces

DCSWI = inboard chord length of surface

DCSWO = outboard chord length of surface

Computation of the front spar and hinge rib cap material weight assumes an additional 2.0 in. on the extrusion length. Rear spar material weight assumes an additional 0.5 in. on all sides of the flap pattern dimensions. Material weight for the skins is computed as the actual weight plus 0.5 in. of additional material on all edges. Of the total skin rivets 32% are assumed to be in each of the inboard and outboard skins, and 36% in the center skin.

Airload ribs are bent-up sheet metal and material weight is based on the flat pattern dimensions plus an additional 1.0 in. in both length and width. Theoretical and actual rib weights assume lightening holes with diameter equal to 75% of average rib height spaced at 1-1/2 diameters.

The nose ribs are assumed to be parabolic. Material weight is based on 1.0 in. added to the length and width of the flat pattern dimensions. Each rib contains one lightening hole with a diameter equal to 75% of the smaller rib chord length or 84.5% of rib height. The hinge rib webs are a solid web with no lightening holes. Material weight is calculated assuming 0.5 in. of additional material on all edges. The honeycomb trailing edge wedge theoretical weight is computed as the theoretical weight times the honeycomb core factor from the stress analysis routines. Material weight is computed assuming a honeycomb block with dimensions equalling the largest web dimensions plus 1.0 in. and adhesive weight.

The parts definition process for the tip assumes the geometry and part dimensions shown in Figure 21. Actual weight for the skin is computed from:

$$WT = 39 (0.032) (TIP\ CHORD) (DENSITY)$$

The material weight for all sheet metal parts assumes an additional 1.0 in. of material on both the length and the width. All attachments assume a single row of 3/16-in. diameter rivets spaced at four diameters

3.3 COMPUTER PROGRAM

The computer program is a series of modularized subroutines, developed for the CDC 6400 computer and now operational on the 6600, to define geometry, perform structural analysis, and develop part definitions for aerodynamic surface leading edge, trailing edge and tips. A listing of these subroutines is separately available.

The subroutines have been developed in such a manner to allow easy integration of any or all subroutines within existing or future development of aircraft sizing and cost synthesis programs. To provide this end the following ground rules were employed:

- a. Total modularity.
- b. Control subroutine with input.
- c. Design for ease of update, modification and integration.
- d. Level of analysis is function of input.

3.3.1 PROGRAM DESCRIPTION. The program as described here is a series of individual modular programs that operate as individual entities. The generalized flow of information from one subroutine to another is as shown in Figure 15. However, each subroutine provides only one part of the total information required for the overall system.

The computer program was designed in a modular fashion as shown in the general overlay structure of Figure 22. The driver has supporting subroutines resident and the primary and secondary overlays are divided by function. The functions include: control surfaces, tips, fixed leading edge, spoilers, fixed trailing edge, and geometry. This overlay provides an operable computer program for easy integration into a total synthesis operation.

The subroutine core requirements, based on the overlay structure shown in Figure 21 is outlined in Table 3. These core requirements are the maximum for each operation.

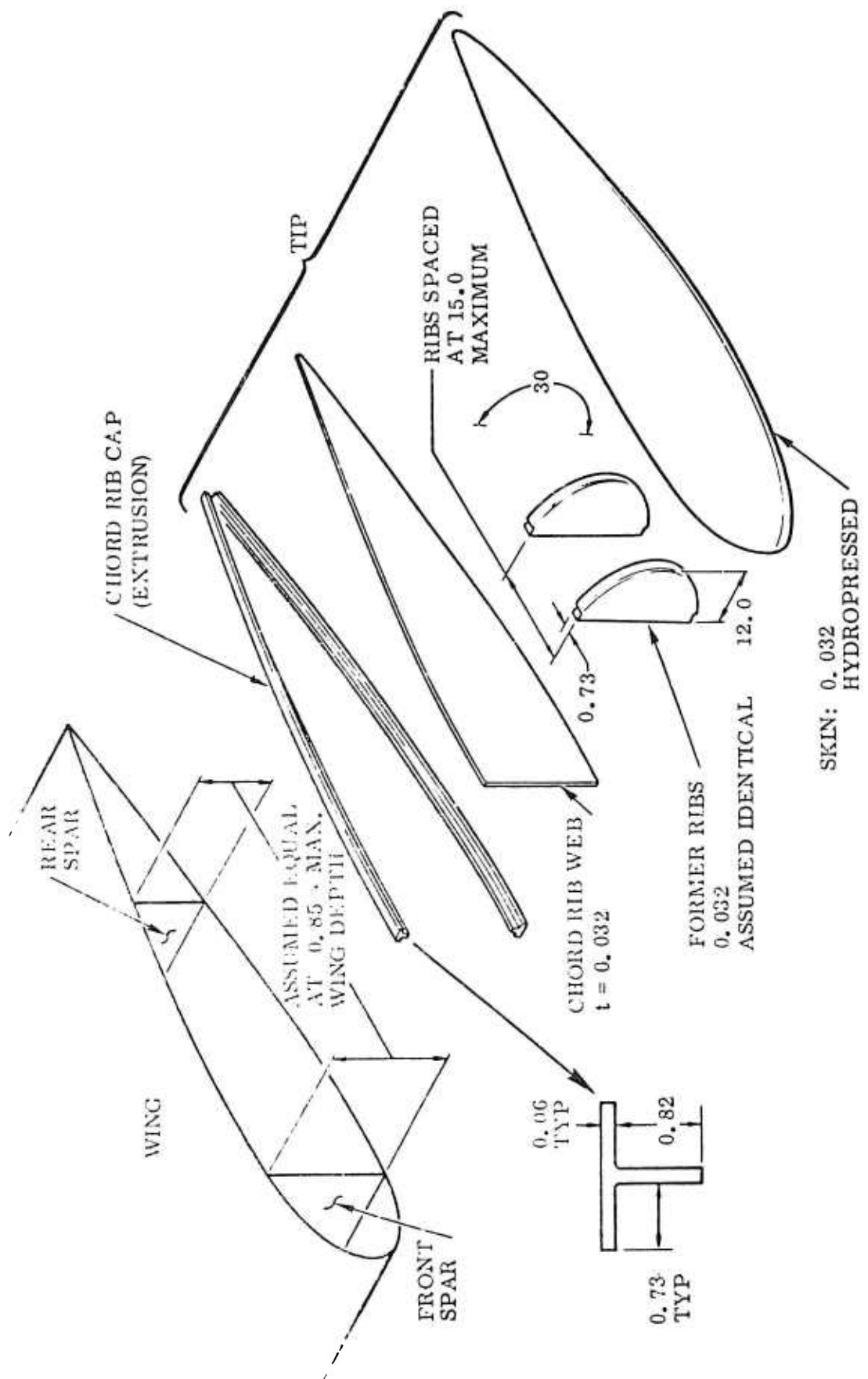

Figure 21. Wing Tip.

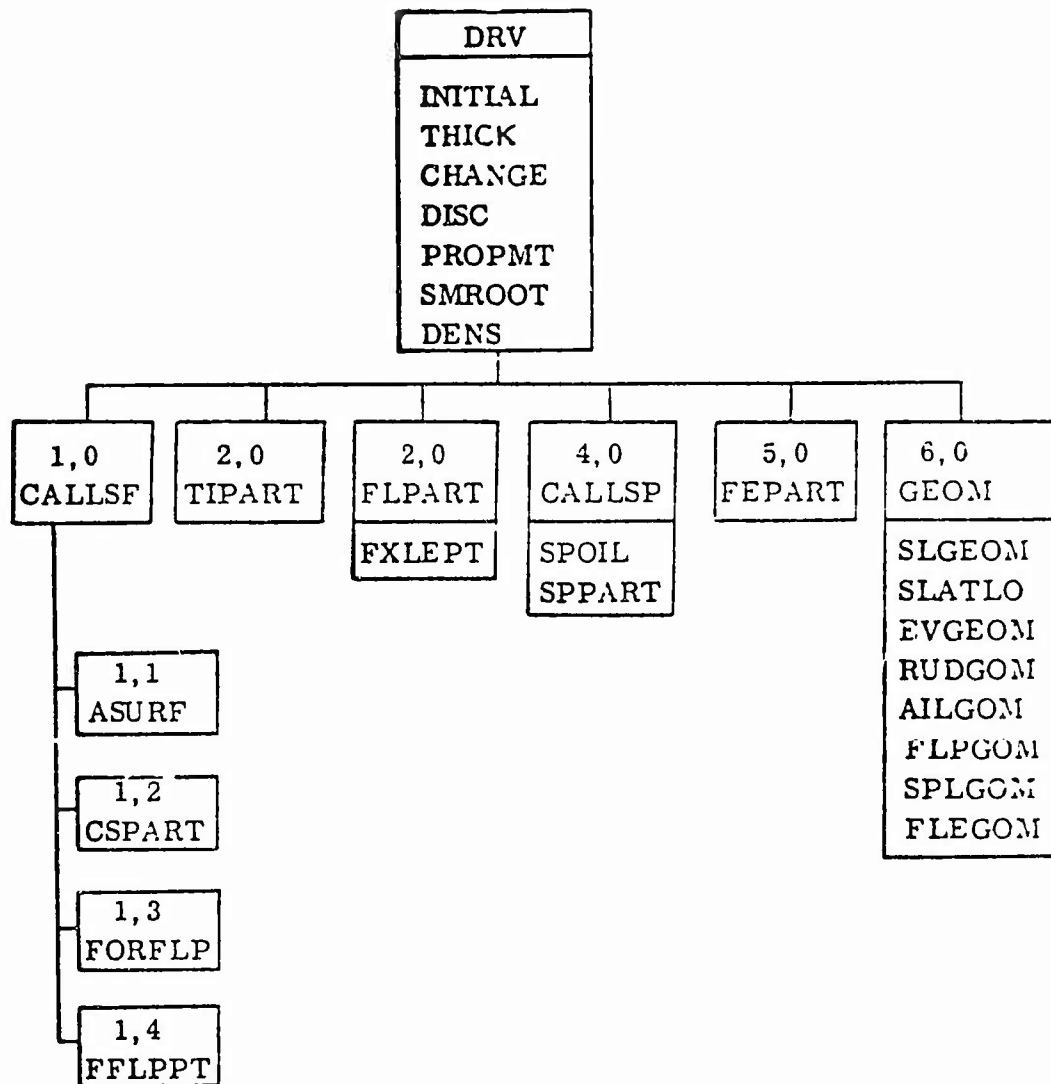

Figure 22. Typical Overlay Structure.

Table 3. Subroutine Core Requirements.

Overlay Designation	Core Required (Octal)
DRV + 1, 0 + 1, 1	42500
DRV + 1, 0 + 1, 2	35000
DRV + 1, 0 + 1, 3	33500
DRV + 1, 0 + 1, 4	32500
DRV + 2, 0	31100
DRV + 3, 0	34000
DRV + 4, 0	36000
DRV + 5, 0	35300
DRV + 6, 0	35000

3.3.2 DESCRIPTION OF SUBROUTINES. The subroutines that were developed within this study effort are described as follows:

DRV is the driver subroutine that acts as the main control routine for the total program. It calls the subroutine in the proper logical sequence as required to perform the task.

INITIAL initializes all variables to their required predetermined value and sets all input variables to zero.

THICK defines control surface cross-section depth as a function of type, span, and chord location.

CHANGE selects the proper material code for each part as a function of input flags.

DISC Stores part sizes and cost parameters.

PROPMT stores the mechanical properties of various materials for use in the stress analysis and part definition routines.

SMROOT calculates the root of a given quadratic equation as required by the different geometry routines.

DENS calls the change routine and provides the appropriate material densities to the part definition routines.

CALLSF subdivides the control surfaces into equal length segments no longer than 180 inches. It also provides the communication link with the appropriate analysis and parts definition routines for each segment.

ASURF provides the structural analysis for the flaps, ailerons, slats, rudder, and elevators. This routine provides part dimensions, actual and theoretical thicknesses, and rivet sizes and quantities.

CSPART utilizes data from ASURF to produce the number, sizes, weights, and cost parameters of all parts for flaps, ailerons, rudders, elevators, and slats.

FORFLP computes spar thicknesses and rivet patterns for the foreflap. The structural analysis is provided by ASURF through the flap routine.

FFLPPT utilizes data from FORFLP to produce the number, sizes, weights and cost parameters for all parts of the foreflap.

TIPART produces the number, sizes, weight, and cost parameters for all surface tip parts.

FLPART utilizes data from FLEGOM to select planform dimensions for each leading edge segment and calls the part definition routine (FXLEPT) for that segment.

FXLEPT produces the number, sizes, weight, and cost parameters for all leading edge parts.

CALLSP provides the spoiler into equal segments of 60-inch lengths maximum. It also serves as the calling routine for spoiler analysis and spoiler and spoiler part definition routines.

SPOIL provides the structural analysis for the spoilers. This routine provides part dimensions, actual and theoretical thickness, and rivet sizes and quantities.

SPPART utilizes data from the spoil routine to produce the number, sizes, weights, and cost parameters of all parts for the spoilers.

FEPART provides quantity, sizes, weights, and cost parameters for fixed trailing edge parts on wings, horizontal stabilizers, and vertical fins.

SLATLO locates inboard and outboard ends of slats for use in the SLGEOM routine.

SLGEOM defines slat planform dimensions and locations from input data.

EVGEOM defines elevator planform dimensions and locations from input data.

RUDGOM defines rudder planform dimensions and locations from input data.

AILGOM defines aileron planform dimensions and locations from input data.

FLPGOM defines foreflap and flap planform dimensions and locations from input data.

SPLGOM defines spoiler planform dimensions and locations from input data.

FLEGOM defines fixed leading edge planform dimensions and locations for wings, horizontal stabilizers, and vertical fins.

3.3.3 USER'S GUIDE. This computer program, LTTWPD, was developed on a CDC 6400 computer. The Convair Aerospace Computer Program Library No. is P5749 and a listing of the program is separately available. This program was written in Fortran IV language in an update file format. It is stored on magnetic tape in the Convair Tape Library, Tape No. 14289.

A namelist type input was used with the variable name, value, and definition of variable name on one card. A complete list of input variables is presented in Table 4. The deck setup for executing the program is illustrated in Figure 23.

The input variables required for each structural type are presented in sample case listings (Tables 5 through 13). All input variables are initialized to zero for each case. Therefore, for multiple case runs you must input variables for each case.

The output consists of input, detail weight and part definition data, and total weight. Sample cases are presented in Table 14.

Table 4. List of Input.

PSINPNL

C
C
C

F-111 WING TIP

CLESI = 0.0	•DEF=55H SLAT INBD.EDGE LOCATION (FACTOR OF SEMI=SPAN)	•
CLESO = 0.0	•DEF=55H SLAT OUTBD.EDGE LOCATION(FACTOR OF SEMI=SPAN)	•
CLMAX = 0.0	•DEF=55H MAXIMUM WING LIFT COEFFICIENT	•
CSCDWC = 0.0	•DEF=55H SURFACE CHORD TO WING CHORD RATIO	•
CWSPIN= 0.0	•DEF=55H RATIO OF INBOARD END OF SPOILER TO WING SEMI=SPAN	•
CWSPOT= 0.0	•DEF=55H RATIO OF OUTBOARD END OF SPOILER TO WING SEMI=SPAN	•
D = 0.0	•DEF=55H SLAT EDGE AND LEADING EDGE STATIONS (FT)	•
DBW = 0.0	•DEF=55H BODY WIDTH (FT)	•
DCSL = 0.0	•DEF=55H SURFACE LENGTH (IN)	•
DCSWI = 0.0	•DEF=55H SURFACE CHORD AT INBOARD END (IN)	•
DCSWO = 0.0	•DEF=55H SURFACE CHORD AT OUTBOARD END(IN)	•
DCSYI = 0.0	•DEF=55H SURFACE INBOARD EDGE LOCATION (DECIMAL OF SEMI=SPAN)	•
DCYSI = 0.0	•DEF=55H LEADING EDGE INBOARD STATION (FT)	•
DCYSO = 0.0	•DEF=55H LEADING EDGE OUTBOARD STATION (FT)	•
DFELC = 0.0	•DEF=55H LENGTH OF LEADING EDGE OUTBOARD OF CENTER SLAT (FT)	•
DFELI = 0.0	•DEF=55H LENGTH OF LEADING EDGE INBOARD OF CENTER SLAT (FT)	•
DFELO = 0.0	•DEF=55H LENGTH OF FIXED LEADING EDGE OUTBOARD OF SLAT (FT)	•
DFEWCI= 0.0	•DEF=55H INBOARD LEADING EDGE CHORD OUTBOARD OF CENTER SLAT-FT	•
DFEWCO= 0.0	•DEF=55H OUTBOARD LEADING EDGE CHORD OUTBOARD OF CENTER SLAT-FT	•
DFEWII= 0.0	•DEF=55H INBOARD LEADING EDGE CHORD INBOARD OF CENTER SLAT-FT	•
DFEWIO= 0.0	•DEF=55H OUTBOARD LEADING EDGE CHORD INBOARD OF CENTER SLAT-FT	•
DFEWOI= 0.0	•DEF=55H INBOARD LEADING EDGE CHORD OUTBOARD OF SLAT (FT)	•
DFEWOO= 0.0	•DEF=55H OUTBOARD LEADING EDGE CHORD OUTBOARD OF SLAT (FT)	•
DFXLE = 0.0	•DEF=55H FIXED LEADING EDGE LENGTH	•
DFXWI = 0.0	•DEF=55H FIXED LEADING EDGE WIDTH INBD	•
DFXWO = 0.0	•DEF=55H FIXED LEADING EDGE WIDTH OUTBD	•
DHB = 0.0	•DEF=55H HORIZONTAL TAIL SPAN	•
DHCR = 0.0	•DEF=55H HO- ZONTAL TAIL ROOT CHORD	•
DHCT = 0.0	•DEF=55H HORIZONTAL TAIL CHORD AT TIP (FT)	•
DHTT = 0.0	•DEF=55H HORIZONTAL TAIL THICKNESS AT TIP (FT)	•
DISWI = 0.0	•DEF=55H INBOARD SLAT INBOARD CHORD (FEET)	•
DISWO = 0.0	•DEF=55H INBOARD SLAT OUTBOARD CHORD (FEET)	•
DLELC = 0.0	•DEF=55H LENGTH OF LEADING EDGE UNDER CENTER SLAT (FT)	•
DLELI = 0.0	•DEF=55H LENGTH OF LEADING EDGE UNDER INBOARD SLAT (FT)	•
DLELO = 0.0	•DEF=55H LENGTH OF LEADING EDGE UNDER OUTBOARD SLAT (FT)	•
DLESLC= 0.0	•DEF=55H CENTER SLAT LENGTH (FEET)	•
DLESLI= 0.0	•DEF=55H INBOARD SLAT LENGTH (FEET)	•
DLESLO= 0.0	•DEF=55H OUTBOARD SLAT LENGTH(FEET)	•
DLEWCI= 0.0	•DEF=55H INBOARD LEADING EDGE CHORD UNDER CENTER SLAT (FT)	•
DLEWCO= 0.0	•DEF=55H OUTBOARD LEADING EDGE CHORD UNDER CENTER SLAT (FT)	•
DLEWII= 0.0	•DEF=55H LEADING EDGE INBOARD CHORD UNDER INBOARD SLAT (FT)	•
DLEWIO= 0.0	•DEF=55H LEADING EDGE OUTBOARD CHORD UNDER INBOARD SLAT (FT)	•
DLEWOI= 0.0	•DEF=55H INBOARD LEADING EDGE CHORD UNDER OUTBOARD SLAT (FT)	•
DLEWOO= 0.0	•DEF=55H OUTBOARD LEADING EDGE CHORD UNDER OUTBOARD SLAT (FT)	•
DOSWI = 0.0	•DEF=55H OUTBOARD SLAT INPCARD CHORD (FEET)	•
DOSWO = 0.0	•DEF=55H OUTBOARD SLAT OUTBOARD CHORD(FEET)	•
DVB = 0.0	•DEF=55H VERTICAL TAIL SPAN	•
DVCR = 0.0	•DEF=55H VERTICAL TAIL ROOT CHORD	•
DVCT = 0.0	•DEF=55H VERTICAL CHORD AT TIP (FT)	•
DVTT = 0.0	•DEF=55H VERTICAL THICKNESS AT TIP (FT)	•
DWB = 0.0	•DEF=55H WING, HORIZ STAB, OR VERT STAB SPAN (FEET)	•
DWCLE = 0.0	•DEF=55H WING CHORD AT SLAT (FT) ACTUALLY AT MIDSPAN OF EXPOSED	•
DWCR = 0.0	•DEF=55H WING CHORD AT THE ROOT (FT)	•
DWCT = 4.1	•DEF=55H WING CHORD AT TIP (FT)	•
DWTT = 0.416	•DEF=55H WING THICKNESS AT THE TIP (FT)	•
DWYENG= 0.0	•DEF=55H ENGINE STATION (FT) TWO-ENGINE AIRPLANE	•

Table 4. List of Input (Continued).

```

DWYIEN= 0.0      ,DEF=55H INBOARD ENGINE STATION (FT) FOUR-ENGINE AIRPLANE
DWYOEN= 0.0      ,DEF=55H OUTBOARD ENGINE STATION (FT)FOUR-ENGINE AIRPLANE
GHFS  = 0.0      ,DEF=55H LOCATION OF HORIZONTAL FRONT SPAR (PERCENT ROOT CHORD)
GHRSS = 0.0      ,DEF=55H LOCATION OF HORIZONTAL REAR SPAR (PERCENT ROOT CHORD)
GVFS  = 0.0      ,DEF=55H LOCATION OF VERTICAL FRONT SPAR (PERCENT ROOT CHORD)
GVRSS = 0.0      ,DEF=55H LOCATION OF VERTICAL REAR SPAR (PERCENT ROOT CHORD)
GWAIL = 0.0      ,DEF=55H RATIO OF INBOARD AILERON STATION TO WING SEMI-SPAN
GWCFFL= 0.0      ,DEF=55H RATIO OF FOREFLAP CHORD TO FLAP CHORD
GWCFLP= 0.0      ,DEF=55H FLAP CHORD TO WING CHORD RATIO
GWCLE = 0.0      ,DEF=55H RATIO OF SLAT CHORD TO WING CHORD
GWFS  =0.24349   ,DEF=55H WING WING FRONT SPAR LOCATION (FACTOR OF WING CHORD)
GWRS  =0.69166   ,DEF=55H LOCATION OF WING REAR SPAR (PERCENT ROOT CHORD)
GWTCR = 0.0      ,DEF=55H WING T/C AT ROOT
GWTCR = 0.0      ,DEF=55H WING T/C AT TIP
NZ     = 0.0      ,DEF=55H DESIGN LOAD FACTOR
QENG  = 0.0      ,DEF=55H NUMBER OF ENGINES
QMAX  = 0.0      ,DEF=55H MAXIMUM DYNAMIC PRESSURE (PSI)
SIGCR = 0.0      ,DEF=55H DENSITY FACTOR AT ALTITUDE
SW     = 0.0      ,DEF=55H WING,HORIZ. STAB.,OR VERT. STAB AREA (SQ.FT.)
SWAIL = 0.0      ,DEF=55H
SWFLAP= 0.0      ,DEF=55H WING FLAP AREA (SQ.FT.)
TIPWI =18.0      ,DEF=55H INPUT TIP WIDTH
TST1  = 3.0      ,DEF=55H DESIGN GROSS WEIGHT (LBS.)
VS    = 0.0      ,DEF=55H STALL SPEED (KNOTS)
ZOLDGM= 0.0      ,DEF=55H FLAG FOR GEOM ROUTINES
L      = 0.0      ,DEF=55H SURFACE NUMBER
C      FOREFLAP= 1 THRU 20
C      FLAP    =21 THRU 25
C      AILERON =26 THRU 30
C      SLAT   =41 THRU 46
C      RUDDER  =47 THRU 51
C      ELEVATOR=52 THRU 56
LSURF =          7,DEF=55H SURFACE CODE
C      1=AILERON
C      2=RUDDER
C      3=ELEVATOR
C      4=FLAP
C      5=SLAT
C      6=FOREFLAP
C      7=TIP
C      8=FIXED LEADING EDGE
C      9=SPOILERS
C     10=FIXED TRAILING EDGE
LL(1) = 0.0      ,DEF=55H NO SLATS-ENTIRE LENGTH IS FIXED LEADING EDGE
LL(2) = 0.0      ,DEF=55H INBOARD SLATS ONLY
LL(3) = 0.0      ,DEF=55H CENTER SLATS ONLY
LL(4) = 0.0      ,DEF=55H OUTBOARD SLATS ONLY
LL(5) = 0.0      ,DEF=55H INBOARD AND CENTER SLATS ONLY
LL(6) = 0.0      ,DEF=55H CENTER AND OUTBOARD SLATS ONLY
LL(7) = 0.0      ,DEF=55H INBOARD AND OUTBOARD SLATS ONLY
LL(8) = 0.0      ,DEF=55H INBOARD,OUTBOARD AND CENTER SLATS ONLY
MATTP=          2,DEF=55H MATERIAL TYPE
C      1 =7075 ALUMINUM
C      2 =2024 ALUMINUM
C      3 =DMS 1794 TITANIUM
C      4 =17-7PH STAINLESS STEEL
C      5 =SAE 1018 STEEL
C      6 =BORON-EPOXY COMPOSITE(0.005 IN)
C      7 =BORON ALUMINUM COMPOSITE
C      8 =GRAPHITE-EPOXY COMPOSITE
C      9 =HEXCEL ALUMINUM HONEYCOMB (1/8 HEX 0.001 FOIL)
DEF=55H F-111 WING TIP

```

SEND

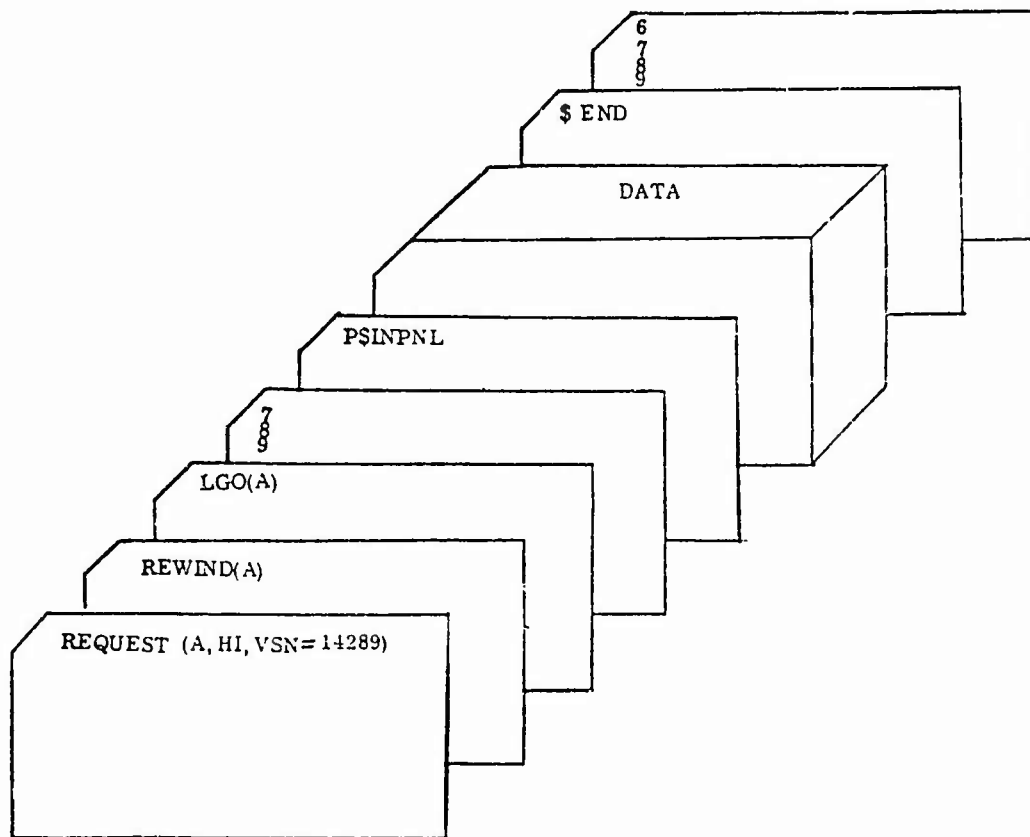

Figure 23. Deck Setup for LTTWPD.

Table 5. Aileron Input.

```

PSINPNL
C
C AX WING AILERONS
C
MATTYP=2.,
LSURF=1.,
DWB=47.75.,
DWCT=4.5.,
GWFS=0.14.,
GWRS=0.535.,
DWCR=11.4.,
VS=100.,
QMAX=950.,
SIGCR=0.4486.,
CLMAX=2.5.,
NZ=7.5.,
SW=380.,
TST1=38300.,
DCSL=72.,
DCSWI=19.8.,
DCSWO=13.5.,
DCSYI=0.746.,
$END

```

Table 6. Rudder Input.

```

PSINPNL
C
C C-5A RUDDER-LOWER
C
LSURF=2.,
MATTYP=2.,
DWB=222.7.,
DVCR=30.93.,
DVCT=24.75.,
GVRS=0.64.,
VS=100.0.,
QMAX=550.0.,
SIGCR=0.4486.,
CLMAX=4.5.,
NZ=3.75.,
SW=6200.0.,
TST1=769000.04
DCSL=208.15.,
DCSWI=133.63.,
DCSWO=133.63.,
$END

```

Table 7. Elevator Input.

```

PSINPNL
C
C C-5A INNER ELEVATOR HORIZONTAL
C
MATTYP=2.,
LSURF=3.,
DWB=222.7.,
DHCR=21.6.,
DHCT=7.7.,
GHR5=0.65.,
VS=100.0.,
QMAX=550.,
SIGCR=0.4486.,
CLMAX=4.5.,
NZ=3.75.,
SW=6200.0.,
TST1=769000.04
DCSL=193.35.,
DCSWI=84.0.,
DCSWO=60.,
$END

```

Table 8. Flap Input.

```

PSINPNL
C
C AX WING FLAPS
C
MATTYP=2.,
LSURF=4.,
DWB=47.75.,
DWCT=4.5.,
GWFS=0.14.,
GWRS=0.535.,
DWCR=11.4.,
VS=100.,
QMAX=950.,
SIGCR=0.4486.,
CLMAX=2.5.,
NZ=7.5.,
SW=380.,
TST1=38300.,
DCSL=182.,
DCSWI=23.,
DCSWO=15.,
GWCFLP=0.26.,
$END

```

Table 9. Slat Input.

```

PSINPNL
C
C AX WING SLATS
C
MATTYP=2,
LSURF=5,
DWB=47.75,
DWCT=4.5,
GWFS=0.14,
GWRS=0.535,
DWCR=11.4,
VS=100.,
QMAX=950.,
SIGCR=0.4486,
CLMAX=2.5,
NZ=7.5,
SW=380.,
TST1=38300.,
D(1)=1.92,
D(2)=5.0,
D(3)=6.2,
D(4)=17.0,
D(5)=17.5,
D(6)=23.0,
DCSWI=1.3,
DCSWO=0.8,
DISWI=1.6,
DISWO=1.4,
DLES LC=10.8,
DLES LI=2.75,
DLES LO=5.83,
DOSWI=0.8,
DOSWO=0.65,
CSCDWC=0.144,
$END

```

Table 10. Fore Flap Input.

```

PSINPNL
C
C AX WING FOREFLAPS
C
MATTYP=2,
LSURF=6,
GWCFFL=0.26,
GWCFLP=0.26,
DWB=47.75,
DWCT=4.5,
GWFS=0.14,
GWRS=0.535,
DWCR=11.4,
VS=100.,
QMAX=950.,
SIGCR=0.4486,
CLMAX=2.5,
NZ=7.5,
SW=380.,
TST1=38300.,
DCSL=182.,
DCSWI=6.,
DCSWO=4.,
$END

```

Table 11. Leading Edge Input

```

PSINPNL
C
C F=111 FIN LEADING EDGE
C
MATTYP=2,
DFXLE =12.33 ,
DFXWI =3.03 ,
DFXWO =1.38 ,
L = 62,
LSURF = 8,
$END

```

Table 12. Trailing Edge Input

```

PSINPNL
C
C C-141 STAB TE
C
MATTYP=2,
L=58,
LSURF=10,
GWTCR=0.106,
GWTCI=0.106,
DHB=50.35,
GHR=0.67,
DHCR=14.06,
DHCT=5.20,
DBW=3.333,
DHB=50.35,
$END

```

Table 13. Spoilers Input.

```

PSINPNL
C
C F-111 SPOILERS
C
DWCT =3.824 ,DEF=55H WING CHORD AT TIP (FT) ;
GWRS =0.65 ,DEF=55H LOCATION OF WING REAR SPAR (PERCENT ROOT CHORD) ;
DWCR =12.506 ,DEF=55H WING CHORD AT THE ROOT (FJ) ;
DCSL =267.4 ,DEF=55H SURFACE LENGTH (IN) ;
DCSWI =21.7 ,DEF=55H SURFACE CHORD AT INBOARD END (IN) ;
DCSWO =11.8 ,DEF=55H SURFACE CHORD AT OUTBOARD END (IN) ;
LSURF = 9,DEF=55H SURFACE IDENTIFICATION FLAG ;
MATYP=2,
CSCDWC=0.162 ,
GWTCR =0.1135 ,
GWTCI =0.085 ,
GWCFLP=0.35 ,
FLPTYP=0.0 ,
DWU=60.533,
DCSYI=0.2561,
SEND

```

Table 14. Sample Output.

PART		L	THEOMT	ACHT	MAHT	MTMA	QTLSKN	STOODPT	STONGT	STDLTH	STOMIO
PEIMPML C F-111 STAS TIP MATVP=2 L SURF = 7 DEF=55H SURFACE IDENTIFICATION FLAG U-CT = 6.0 DEF=55H HORIZONTAL CHORD AT TIP (FT) D-TI = 1.2 DEF=55H HORIZONTAL THICKNESS AT TIP (FT) GHS = 0.10 DEF=55H LOCATION OF HORIZONTAL FRONT SPAR (PERCENT ROOT CHORD) GHS = 0.70 DEF=55H LOCATION OF HORIZONTAL REAR SPAR (PERCENT ROOT CHORD) END											
SURF	L.C. SKIN	64	6.91	6.91	7.97	7.97	0.00	.03	12.24	72.00	30.00
		JT	KK	HOLES	DIAH	QTSKIN	MIO	KT			
	KEY	MATLIO	DIA	EL	PERH	THK					
		2	0.00	72.00	0.00	12.24	30.00	1			
SURF	MOSE RIB 1	64	.05	.05	.13	.13	0.00	.03	.73	13.70	1.46
		JT	KK	HOLES	DIAH	QTSKIN	MIO	KT			
	KEY	MATLIO	DIA	EL	PERH	THK					
		2	0.00	13.70	0.00	.73	1.46	5			
SURF	IMR UP CAP	64	.91	.91	1.02	1.02	0.00	.09	.08	64.00	1.52
		JT	KK	HOLES	DIAH	QTSKIN	MIO	KT			
	KEY	MATLIO	DIA	EL	PERH	THK					
		2	1.52	64.00	4.50	.08	1.52	1			
SURF	IMR LR CAP	64	.91	.91	1.02	1.02	0.00	.09	.08	64.00	1.52
		JT	KK	HOLES	DIAH	QTSKIN	MIO	KT			
	KEY	MATLIO	DIA	EL	PERH	THK					
		2	1.52	64.00	4.50	.08	1.52	1			
SURF	IMR WEB	64	2.12	2.12	1.53	1.53	0.00	.09	.03	64.00	12.24
		JT	KK	HOLES	DIAH	QTSKIN	MIO	KT			
	KEY	MATLIO	DIA	EL	PERH	THK					
		2	0.00	64.00	0.00	.03	12.24	1			

64
TOTAL WEIGHT= 11.103

SECTION IV

REFERENCES

1. Gary S. Kruse and Larry M. Peterson, "Automated Structural Sizing Techniques for Aircraft and Aerospace Vehicle Structures," General Dynamics Report, GDCA-ERR-1748, December, 1972.
2. Kuhn, Peterson, and Levin, "A Summary of Diagonal Tension, Part I, Methods of Analysis. NACA TN 2661.
3. "Design of Webs of Integrally Stiffened Panels, F-111 Design Allowables, General Dynamics Convair Report FZS-12-141.
4. Carlos A. Garroccq, "Optimum Solidity," ASME 65-AV-21, April 1965.
5. Carlos A. Garroccq, "Synthesis of Structural Elements, Subcomponents, and Components," General Dynamics Convair Report GDC-ERR-1402, December 1969.
6. R. L. Holt, "Applications of Lifting Line Theory to Aircraft Aero-Elastic Loads Analysis," General Dynamics Convair Report GDC-ERR-1128, February 1968.
7. R. L. Holt, "Modified Weissinger L-Method of Aeroelastic Load Analysis of Wings with Large Engine Pods and of Wings with Unsymmetrical Spoiler Deflection," General Dynamics Report GDC-ERR-1446, December, 1969.
8. E. F. Bruhn, "Analysis and Design of Flight Vehicle Structures," Tri-State Offset Company, Cincinnati, Ohio, 1965.