

AD/A-005 774

METAL-MATRIX COMPOSITES: STATUS AND PROSPECTS

NATIONAL MATERIALS ADVISORY BOARD (NAS-NAE)

PREPARED FOR  
DEPARTMENT OF DEFENSE  
NATIONAL AERONAUTICS AND SPACE ADMINISTRATION

DECEMBER 1974

DISTRIBUTED BY:

**NTIS**

**National Technical Information Service  
U. S. DEPARTMENT OF COMMERCE**

REPORT DOCUMENTATION PAGE		READ INSTRUCTIONS BEFORE COMPLETING FORM
1. REPORT NUMBER <b>NMAB-313</b>	2. GOVT ACCESSION NO.	3. RECIPIENT'S CATALOG NUMBER <b>ADIA-005774</b>
4. TITLE (and Subtitle) <b>Metal Matrix Composites: Status and Prospects</b>		5. TYPE OF REPORT & PERIOD COVERED <b>Final</b>
		6. PERFORMING ORG. REPORT NUMBER
7. AUTHOR(s) <b>NMAB ad hoc Committee on Metal-Matrix Composites</b>		8. CONTRACT OR GRANT NUMBER(s) <b>MDA903-74-C-0167</b>
9. PERFORMING ORGANIZATION NAME AND ADDRESS <b>National Materials Advisory Board National Academy of Sciences 2101 Constitution Ave., Washington, DC 20418</b>		10. PROGRAM ELEMENT, PROJECT, TASK AREA & WORK UNIT NUMBERS
11. CONTROLLING OFFICE NAME AND ADDRESS <b>Department of Defense National Aeronautics &amp; Washington, D.C. Space Administration</b>		12. REPORT DATE <b>December 1974</b>
		13. NUMBER OF PAGES <b>115</b>
14. MONITORING AGENCY NAME & ADDRESS (if different from Controlling Office) <b>Mr. Jerome Persh Staff Specialist for Materials and Structures (Engi- neering Technology) Department of Defense, Washington, D.C. 20301</b>		15. SECURITY CLASS. (of this report) <b>Unclassified</b>
		15a. DECLASSIFICATION DOWNGRADING SCHEDULE
16. DISTRIBUTION STATEMENT (of this Report)  <b>This document has been approved for public release and sale; its distribution is unlimited.</b>		
17. DISTRIBUTION STATEMENT (of the abstract entered in Block 20, if different from Report)		
18. SUPPLEMENTARY NOTES  Reproduced by <b>NATIONAL TECHNICAL INFORMATION SERVICE</b> US Department of Commerce Springfield, VA. 22151  <b>PRICES SUBJECT TO CHANGE</b>		
19. KEY WORDS (Continue on reverse side if necessary and identify by block number) <b>Aluminum Composites Graphite Beryllium Fabrication Magnesium Boron Fibers Metal-Matrix</b>		
20. ABSTRACT (Continue on reverse side if necessary and identify by block number)  <b>The role that metal-matrix composites should be playing in Department of Defense applications was examined in the context of the many favorable aspects, often leading to improved performance, of this new class of materials. Their potential drawbacks also were reviewed.</b>  <b>The current state of the art in primary and secondary fabrication is presented as is a review of many possible applications. Major attention by the</b>		

Committee to present and projected costs led to the conclusion that metal-matrix composites are now competitive in cost for several applications and will become competitive for many additional applications.

In airframe applications, sufficient background has been generated to predict that this class of materials will survive on its own merits and will be used increasingly in competition with other materials as designers become familiar with its properties. Confidence in the material and in its fabrication capabilities must be increased by support of manufacturing and flight exposure in a manner similar to that employed for epoxy-matrix composites.

One example of a potential application (which can be expected to result in a substantial gain in performance) is use in fan blades for jet engines. Its use will require extensive and expensive engine testing to insure suitability in the same way that is necessary for other engine improvements. Resistance to foreign object damage also must be verified. This is one of the developments for which government support is recommended.

1 a.

**METAL-MATRIX COMPOSITES:  
STATUS AND PROSPECTS**

**REPORT OF**

**THE AD HOC COMMITTEE ON  
METAL-MATRIX COMPOSITES**

**NATIONAL MATERIALS ADVISORY BOARD  
Commission on Sociotechnical Systems  
National Research Council  
National Academy of Sciences-National Academy of Engineering**

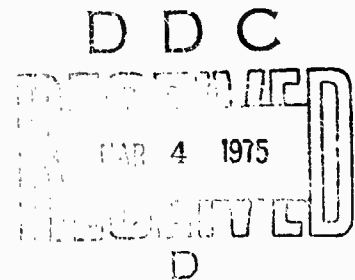

Publication NMA-313  
National Academy of Sciences  
Washington, D. C.

December 1974

*i b*



## NOTICE

The project which is the subject of this report was approved by the Governing Board of the National Research Council, acting in behalf of the National Academy of Sciences. Such approval reflects the Board's judgment that the project is of national importance and appropriate with respect to both the purposes and resources of the National Research Council.

The members of the committee selected to undertake this project and prepare this report were chosen for recognized scholarly competence and with due consideration for the balance of disciplines appropriate to the committee. Responsibility for the detailed aspects of this report rests with that committee.

Each report issuing from a study committee of the National Research Council is reviewed by an independent group of qualified individuals according to procedures established and monitored by the Report Review Committee of the National Academy of Sciences. Distribution of the report is approved, by the President of the Academy, upon satisfactory completion of the review process.

---

This study by the National Materials Advisory Board was conducted under Contract No. MDA903-74-C-0167 with the Department of Defense and NASA.

Members of the National Materials Advisory Board study groups serve as individuals contributing their personal knowledge and judgments and not as representatives of any organization in which they are employed or with which they may be associated.

The quantitative data published in this report are intended only to illustrate the scope and substance of information considered in the study and should not be used for any other purpose, such as in specifications or in design, unless so stated.

Requests for permission to reproduce this report in whole or in part should be addressed to the National Materials Advisory Board.

---

For sale by the National Technical Information Service (NTIS), Springfield, Virginia 22151.

NATIONAL ACADEMY OF SCIENCES-NATIONAL RESEARCH COUNCIL

NATIONAL MATERIALS ADVISORY BOARD

AD HOC COMMITTEE ON METAL MATRIX COMPOSITES

Chairman: Dr. Niranjn M. Parikh  
Director, Metals Research  
IIT Research Institute  
10 West 35th Street  
Chicago, Illinois 60616

Members

Mr. Jack Christian  
Staff Scientist  
Materials Research  
Department 643-10  
General Dynamics/Convair  
Aerospace Division  
Kearny Mesa Plant  
P.O. Box 1128  
San Diego, California 92112

Mr. G. Kirby Dawson  
Senior Industrial Economist  
Stanford Research Institute  
333 Ravenswood Avenue  
Menlo Park, California 94025

Mr. J. F. Dolowy, Jr.  
DWA Composite Specialists, Inc.  
22072 Rayen Street  
Canoga Park, California 91304

Dr. Vernon L. Goodwin  
452 East 300 Street  
Willowick, Ohio 44094

Mr. Robert W. Harrison  
Manager, Composite Blade Development  
Mail Drop - 85  
Aircraft Engine Group  
General Electric Company  
Cincinnati, Ohio 45215

Dr. Paul Hoffman, V. P.  
Materials and Chemical Processes  
Systems Division  
Avco Corporation  
Lowell, Massachusetts 01851

Mr. R. J. Juergens  
Branch Manager  
Material & Process Development  
Dept. 402, Bldg. 33  
McDonnell Aircraft Company  
St. Louis, Missouri 63166

Dr. Richard Kebler  
Program Manager  
Linde Division  
Union Carbide Corporation  
1500 Polco Street  
Indianapolis, Indiana 46224

Mr. Bryan Noton  
Battelle-Columbus Laboratories  
505 King Avenue  
Columbus, Ohio 43201

Mr. M. A. Siegel, Manager  
Long Range Planning  
Pratt & Whitney Aircraft Division  
of United Aircraft Corporation  
Florida Research & Development Center  
West Palm Beach, Florida 33400

Dr. Istvan J. Toth  
Section Manager  
Materials Technology  
TRW Equipment  
23555 Euclid Avenue  
Cleveland, Ohio 44117

Liaison Representatives

Department of Defense

Mr. Jerome Persh  
Staff Specialist for Materials and  
Structures (Engineering Technology)  
Office, Director of Defense  
Research and Engineering  
Department of Defense  
Washington, D. C. 20301

Department of the Army

Dr. A. P. Levitt  
Metals Division  
U.S. Army Materials and Mechanics  
Research Center  
Watertown, Massachusetts 02172

Department of the Navy

Mr. Walter J. Fedyna  
Head, Composites Section (3023)  
Aeronautical Materials Laboratory  
Naval Air Development Center  
Warminster, Pennsylvania 18974

Department of the Air Force

Major C. David Stuber  
AFWL/DYV  
Kirtland AFB, New Mexico 87117

Department of the Air Force (cont'd.)

Mr. Vincent DiBenedetto  
Manufacturing Technology Division  
AFML/LTN  
Wright Patterson Air Force Base  
Ohio 45433

National Aeronautics and Space  
Administration

Mr. Robert A. Signorelli  
Materials & Structures Division  
NASA Lewis Research Center  
21000 Brookpark Road  
Cleveland, Ohio 44135

NMAB Staff Member

Dr. Joseph R. Lane  
Staff Metallurgist  
National Materials Advisory Board  
National Research Council  
NAS-NAE  
2101 Constitution Avenue, N.W.  
Washington, D. C. 20418

## ACKNOWLEDGEMENTS

George Peterson and Theodore Norbert of Wright-Patterson Air Force Base, and Dr. Rodney Cornish of IIT Research Institute addressed the Committee, and together with Mr. S. Dastin (Grumman Aerospace Corporation), Mr. M. Kinna (Naval Sea Systems Command), Mr. D. Kuehl (Composite Materials Corporation) and Roger Pepper, (Fiber Materials, Inc.), participated in Committee discussion. The Committee wishes to express its appreciation to these individuals for the time and effort expended. The opinions expressed herein are those of the Committee and not necessarily those held by the above guests.

## ABSTRACT

The role that metal-matrix composites should be playing in Department of Defense applications was examined in the context of the many favorable aspects, often leading to improved performance, of this new class of materials. Their potential drawbacks also were reviewed.

The current state of the art in primary and secondary fabrication is presented as is a review of many possible applications. Major attention by the Committee to present and projected costs led to the conclusion that metal-matrix composites are now competitive in cost for several applications and will become competitive for many additional applications.

In airframe applications, sufficient background has been generated to predict that this class of materials will survive on its own merits and will be used increasingly in competition with other materials as designers become familiar with its properties. Confidence in the material and in its fabrication capabilities must be increased by support of manufacturing and flight exposure in a manner similar to that employed for epoxy-matrix composites.

One example of a potential application (which can be expected to result in a substantial gain in performance) is use in fan blades for jet engines. Its use will require extensive and expensive engine testing to insure suitability in the same way that is necessary for other engine improvements. Resistance to foreign object damage also must be verified. This is one of the developments for which government support is recommended.

CONTENTS		<u>Page</u>
I.	PURPOSE AND OBJECTIVES . . . . .	1
II.	CONCLUSIONS AND RECOMMENDATIONS . . . . .	5
III.	GENERAL STATUS OF FIBERS AND COMPOSITES DEVELOPMENT . . . . .	9
IV.	FABRICATION . . . . .	28
V.	SUMMARY OF HARDWARE BUILT . . . . .	38
VI.	ADVANTAGES AND DISADVANTAGES OF METAL-MATRIX COMPOSITES . . . . .	56
VII.	COMPONENTS AND SYSTEMS FOR WHICH METAL-MATRIX COMPOSITES ARE CANDIDATES . . . . .	58
VIII.	PRICE PROJECTIONS . . . . .	63
IX.	CASE FOR METAL-MATRIX COMPOSITES . . . . .	80
X.	IMPEDIMENTS TO USAGE OF METAL-MATRIX COMPOSITES .	92
XI.	DATA NEEDS . . . . .	96
	REFERENCES AND BIBLIOGRAPHY . . . . .	103

## I. PURPOSE AND OBJECTIVES

The overall purpose of the study described in this report was to determine the role of metal-matrix composites particularly in Department of Defense (DoD) applications. To accomplish this the National Materials Advisory Board appointed the ad hoc Committee on Metal-Matrix Composites to conduct a detailed analysis of the status of metal-matrix composites from metallurgical, engineering, economic, and applications standpoints. In view of the subject's complexity and multidisciplinary nature, (i.e., including materials science, engineering properties, fabrication processes, structural design concepts, methods of assembly, quality control and nondestructive testing techniques, and economics), the Committee comprised individuals possessing expertise in the various disciplines required. Each Committee member was asked to write on a particular topic, and these papers, after modification based on Committee discussion, comprise chapters of this report. Since no member is knowledgeable in all aspects of the subject it should not be presumed that any member endorses all the statements in this report. The summary and conclusions, however, have been reviewed and approved by the entire Committee membership.

The Committee was asked to assess the prospects for metal-matrix composites and to determine whether the prices of metal-matrix composites will be reduced sufficiently, as volume expands, to make the material a viable option for designers. While the technical "case" for metal-matrix composites was examined by the Committee, major effort was expended on forecasting the price prospects.

Specific subjects receiving Committee attention were:

1. The state of the art of metal-matrix composites
2. The advantages and disadvantages of metal-matrix composites in comparison with both monolithic-wrought materials and resin-matrix composites

3. The potential of metal-matrix composites in DoD, NASA, and commercial applications
4. Fabrication capabilities and the status of the data base for metal-matrix composites
5. Relevant cost projections including some comparison of metal-matrix composites with other materials
6. Previous service experience with metal-matrix composites
7. Current impediments and requirements for expediting wider use of metal-matrix composites

The problem of material shortages, currently receiving much attention, arose after the Committee was organized and, hence, was not considered to any great extent by the Committee.

Composite materials provide their full weight and cost advantages in new designs when they are fully utilized (as shown in engine cross section in Figure 1). A study conducted by the U. S. Air Force (USAF) to determine the impact of composites upon a total engine system clearly indicated significant improvements in cost and weight, not only in the composite parts but also when the higher performance attainable with the composite parts made possible elimination of conventional metal parts and engine stages. It should be pointed out, however, that significant operating experience and confidence in composite parts will be required before total commitment can be made to their use in an original design. The trend today, as with other new materials, is to gain the necessary confidence by direct substitution of composite parts for metal parts, thus ensuring that a backup or alternative part will be available should unforeseen problems arise. The user will require this insurance, which reduces the cost and weight payoff, until he has the necessary confidence in composite materials to commit fully.

The state of the art of metal-matrix composites has changed rapidly during the past 10 years and particularly during the period of this Committee's activity. While composites application was considered originally to effect weight reduction, the more recent desire to reduce the acquisition and operating costs of

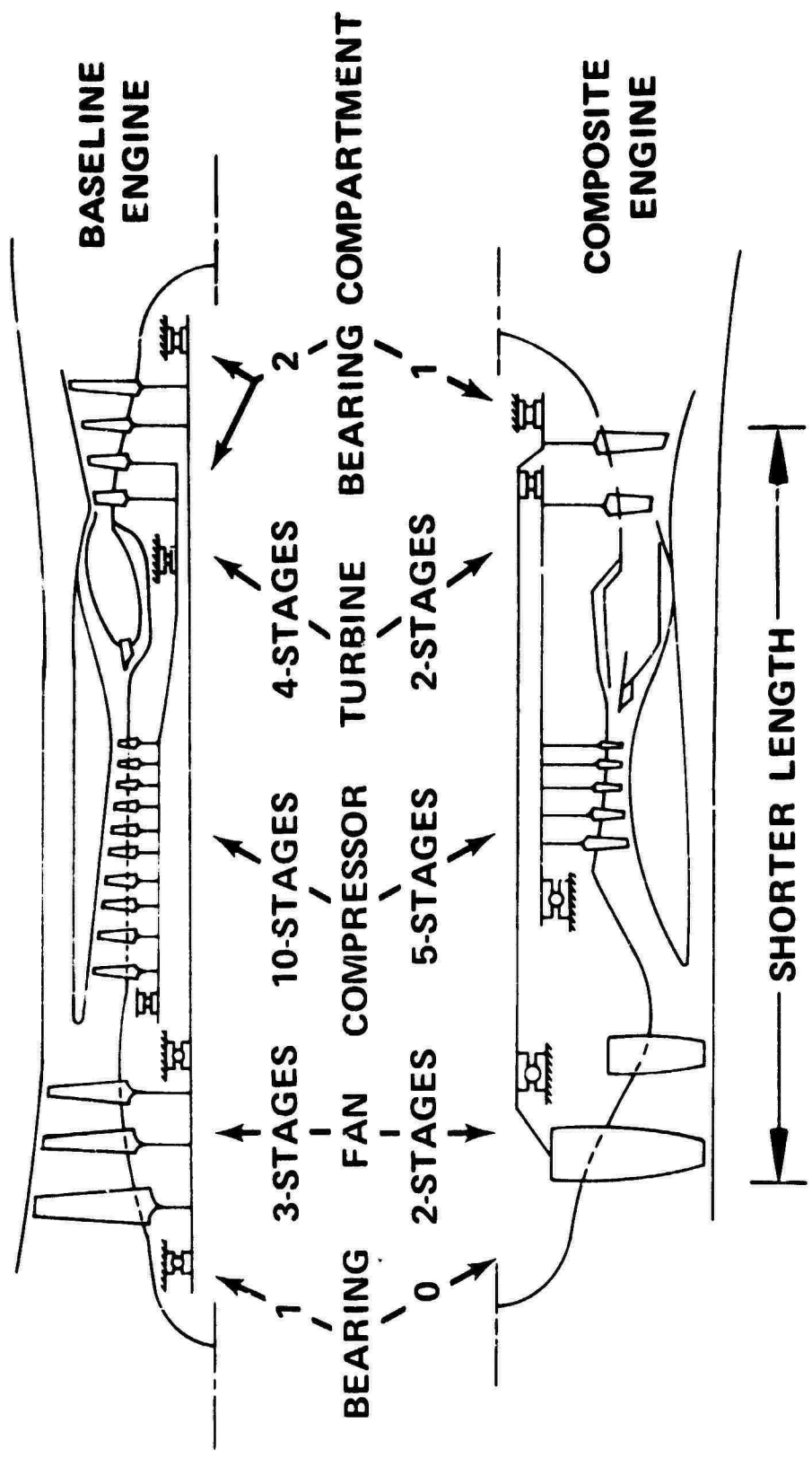

FIGURE 1 Composite fan blade payoffs.

systems has overshadowed the weight-reduction criteria. Thus, acceptance of most current applications require cost reduction or, at the very least, significant weight-reduction with no increase in cost. These requirements have been met in several recent aerospace applications, notably, boron/aluminum structural members for the NASA space shuttle vehicle now in production and boron/aluminum vanes for aircraft engines. These applications provide weight reductions at significant cost savings and, in this Committee's opinion, represent the needed evidence of application capability to warrant acceptance of metal-matrix composites as a viable material system.

The committee started work in 1973 and essentially completed its task in early 1974. Price projections and other data, therefore, are associated with that time period.

## II. CONCLUSIONS AND RECOMMENDATIONS

### A. CONCLUSIONS

#### 1. General

- a. Metal-matrix composites offer sufficient promise and have reached the degree of maturity that indicates an expansion of their use. To realize their full potential, however, these composites deserve greater attention and support.
- b. The advantages of metal-matrix composites over the monolithic metals are high intrinsic strengths, high specific strengths and moduli, toughness, desirable high-temperature properties and stability, and, in some cases, lower cost. They also can be fabricated by more-or-less conventional metalworking techniques.
- c. A number of metal-matrix composites systems currently are in various stages of development: these are boron/aluminum, boron/titanium, graphite/aluminum, graphite/magnesium, beryllium/titanium, and superalloys reinforced with refractory metal or oxide filaments. While the Committee objects in principle to the dilution of development effort, it sees no basis for eliminating research on any of the above systems.
- d. The boron/reinforced aluminum system is in the most advanced stage of development, and property data for this system are sufficient for design in structural applications.
- e. As is true for any new material, methods and standards for overhaul and repair (including nondestructive evaluation techniques) require development before systems go into production. Since many metal-matrix composites may be less prone to corrosion than the alloys they would replace (e.g., high-strength steel in landing gears), maintenance may be less costly. The nature and extent of upkeep can be established only by flight tests and routine service exposure.
- f. The economy of using metal-matrix composites will be more apparent if life-cycle costs rather than installed costs alone are considered. These materials, introduced in the preliminary design stage, could impart maximum benefit to the system.

g. The projected cost reduction for the boron filaments for B/Al, B/Ti, and Be/Ti composites is based on economy of volume alone and not on any technical improvements in manufacture. Even with present-day prices, in a few selected instances components made from metal-matrix composites appear to be less expensive than equivalent forged titanium or steel parts.

h. To date, metal-matrix composites appear to be closer to substantial use in airframe applications than in engine applications, contrary to the usual sequence of introduction of new materials and despite the fact that the potential payoff is greater for their use in engine applications.

i. The future of metal-matrix composites appears to be almost strictly dependent upon the defense and aerospace industry; no sizable commercial market is seen for the metal-matrix composites in the foreseeable future, although sports equipment manufacturers have made test articles for evaluation.

## 2. Regarding Airframe Applications

a. Currently, several weapons systems are being investigated for possible application of B/Al composites; these include B-1, V-STOL, light weight fighter, etc.

b. B/Al components are committed to the space shuttle application.

c. To date, most airframe applications of metal-matrix composites have been evolved through substitution rather than from preliminary design.

d. It is difficult and dangerous to generalize but with some metal-matrix composites, such as B/Al and Be/Ti, more-or-less conventional equipment is usable for composite manufacture in contrast to equipment needed for making polymer parts. Depending upon applications, however, substantial equipment investment may be necessary.

e. No substantial production experience is available anywhere in the country for metal-matrix composites.

### **3. Regarding Engine Applications**

- a. To date, no commitment exists for the use of any metal-matrix composite in any engine.**
- b. Substituting metal-matrix composites for titanium or steel, particularly in high-tip-speed fans, appears to offer substantial performance, weight, and even cost advantages.**
- c. One of the major obstacles or impediments to the use of composites (either resin matrix or metal-matrix) in fan blades of turbo-fan engines is their reduced resistance to foreign object damage. It must be pointed out that foreign object damage (FOD) resistance testing methods are simply screening tests. Work on several experimental and analytical approaches is under way, and the analytical methods show some promise of providing the ability to design around the FOD problem. In general, confidence in satisfying FOD behavior is hard and expensive to attain.**
- d. For engine applications, some design and manufacturing knowhow exists. However, no production experience is available. The production equipment employed for engine applications may be much more complex and expensive than the equipment used for airframe components.**
- e. Little or no experience is available for nondestructive testing (NDT) or maintenance and repair of metal-matrix composite engine components.**
- f. For qualification, a flight test with new materials is much more important than a spin test; however, it also is much more expensive.**

**B. RECOMMENDATIONS**

1. Laboratory projects on metal-matrix systems should be initiated on a priority basis. The B/Al system, which is close to production, should be introduced into new weapons systems. Systems in the exploratory research phase like graphite/aluminum and superalloy/refractory filaments should be accelerated since the long-term payoff can be quite large. However, careful selection of systems to scale up is recommended.
2. Whenever possible, consideration should be given to metal-matrix composites in the preliminary design stage and, therefore wider dissemination to designers of information about these composites is needed.
3. As with any new technology, continuing attention should be paid to decreasing the costs of production of the basic material, in this case, the cost of filaments and fabrication.
4. As some of these systems are committed to production, the need for well defined quality control, maintenance, and repair procedures will become greater.
5. For engine applications, commitments should be made for a number of flight tests with the new materials.
6. While the FOD problem has not been demonstrated to be solved, several investigators have reported startling improvements in B/Al system toughness resulting from the use of a ductile aluminum alloy and larger boron filaments. Hence, both analytical and experimental work should be continued in the FOD area.
7. The greatest payoff in engine applications offered by metal-matrix composites can be had in the turbine end; therefore, laboratory work on reinforced superalloys should be continued.
8. Standardized design allowables (as in Mil-Hdbk. 5) are needed to facilitate the selection of and commitment to metal-matrix composites.

### III. GENERAL STATUS OF FIBERS AND COMPOSITE DEVELOPMENT

Some composite materials have emerged from the laboratory into the world of commerce; others are under intensive development for near-term application; still others are the subjects of exploratory research that, if successful, could lead to future application. The current status of metal-matrix composites and their reinforcing fibers is reviewed below to indicate their general state of development and typical properties, as well as the general direction of research activity.

As noted above, the general problem of materials shortages and inflated prices has arisen since the Committee began work, and these considerations are not reflected in this report. In general, however, the result of such pressures will be to encourage or accelerate consideration and introduction of materials such as composites since their cost and availability has become relatively more favorable.

#### A. REINFORCING FIBERS

A relatively stable family of reinforcing fiber has been developed with the bulk of research efforts devoted to improvement of properties, reduction of scatter, increased yield, and lower cost. Typical properties of fibers are identified in Table 1.

##### 1. Boron

Continuous filament of boron is produced commercially by chemical vapor decomposition from boron trichloride onto a heated tungsten substrate. Silicon-carbide-coated boron also is available. The coating serves to reduce reaction between matrix and fiber, particularly during high-temperature composite fabrication processing. Production capability appears adequate for contemplated applications. Boron filament is being used for aerospace structural components in polymer-matrix composites, increasing quantities are being used for consumer products.

TABLE 1 Typical Properties of Reinforcing Fibers

Fiber	Diameter (mils)	Density (lb/in <sup>3</sup> )	Tensile Strength (rm. temp. ksi)	Elastic Modulus (rm. temp. ksi)	Commercial Source
Boron	4.0	0.094	500	58	Avco, CMC <sup>a</sup>
	5.6	0.091	500	58	Avco, CMC
	8.0	0.087	550	58	Avco, CMC
Borsic <sup>R</sup>	4.2	0.099	437	58	CMC
	5.7	0.097	462	58	CMC
Silicon carbide	4.0	0.123	450	62	Avco
	5.6	0.119	450	62	Avco
Stainless steel	3.0	0.300	560	30	Crucible Steel
Tungsten alloy	15.0	0.700	458	57	Westinghouse
Columbium alloy	15.0	0.380	235	--	Westinghouse
Aluminum oxide (single crystal)	10.0	0.143	600	62	Tyco, A. D. Little
Graphite					
Gv 70	0.32	0.071	250	77	Celsnese
Type A	0.36	0.065	390	28	Hercules
HMS	0.32	0.068	200	53	Hercules
HTS	0.35	0.620	350	36	Hercules
HMG 50	0.30	0.061	287	50	Hitco
Fortafil 4T	--	0.061	350	37	Great Lakes
Fortafil 5T	--	0.065	400	48	Great Lakes
Fortafil 6T	--	0.069	420	59	Great Lakes
Fiberally 300	0.24	0.065	320	60	Monsanto
Modmor 1	0.31	0.072	250	60	Whitaker/Narmco
Modmor H	0.32	0.063	400	40	Whitaker/Narmco
Thornel 50	--	0.060	315	57	Union Carbide
Thornel 75	--	0.066	380	79	Union Carbide
Thornel 300	--	--	325	34	Union Carbide

Advanced Composite Design Guide, Vol IV, Materials, 3rd Ed. (1973); D.W. Petrasek, High Temperature Strength of Retractory Metal Wires and Considerationf for Composite Applications, NASA TN D-6881 (1972); J. S. Haggerty, Production of Fibers by a Floating Zone Fiber Drawing Technique, NASA CR 120948 (1972).

<sup>a</sup> Composite Materials Corporation

The 5.6-mil-diameter filament is now standard for metal-matrix composites, replacing the 4-mil size. More recently 8-mil-diameter filaments with superior transverse strength and lower cost have become available in aluminum-matrix composites. The larger-diameter filament reduces the number of plies for a given component, thus reducing component fabrication effort. The larger diameter, however, can be disadvantageous for thin sections or for transition points where a large number of plies permits greater design flexibility for multi-axial stress requirements. Of course, a combination of both large- and small-diameter filaments could offer the advantages of both.

## 2. Graphite

Small-diameter graphite or carbon fibers are available from a number of producers as multifiber yarn or tow with a variety of properties. The fiber is produced by pyrolysis of an organic precursor. The form, type, and properties vary as indicated in Table 1. Large quantities of graphite multifiber yarn and tow are used for resin-matrix composites. Demand for sports equipment containing graphite fiber composite has increased consumption significantly. Metal-matrix composites, primarily aluminum and magnesium, have used limited quantities of graphite fiber. Research to increase the strength and modulus of graphite fiber is continuing; however, the thrust of development work is more toward lower cost and higher production rates than toward higher specific properties.

Limited success has been achieved in developing large-diameter graphite monofilament for use in metal-matrix composites. Large-diameter graphite would permit the use of composite fabrication techniques already developed for other filaments such as boron and silicon carbide. Three general processes have been investigated in an attempt to make large-diameter graphite monofilament: One method, pyrolysis of an organic precursor, was based on that used to make small-diameter multifiber graphite; however, a large-diameter organic fiber was used as the precursor instead of a small one. The second method, chemical vapor decomposition (CVD) on a heated substrate, is similar to the method used

for boron except that a graphite substrate is used. The third method, impregnation of resin into a bundle of small-diameter multifiber graphite followed by pyrolysis of the impregnated resin, results in a monofilament of graphite-fiber-reinforced graphite matrix. Continuous filaments from about 3.5 mils to 6 mils in diameter have been produced by the CVD method, but additional research is necessary to reduce scatter, increase average strength, and reduce cost of this experimental fiber. Exploratory composite fabrication has been performed with an aluminum matrix.

### 3. Silicon Carbide

Silicon carbide filament produced by chemical vapor decomposition is commercially available in 4- and 5.6-mil diameters as continuous filament with properties as shown in Table 1. This filament has higher temperature capability than boron because of its inherent greater strength and decreased reaction with metal-matrix materials such as titanium. Silicon-carbide-coated boron filament, which is in commercial production, also is used to reduce matrix/filament reaction. Currently available commercial production capacity for 3 to 5 pounds of silicon carbide filament per week appears adequate for experimental purposes, but increased plant capacity would be required for an application such as turbine blades.

### 4. Metal Wire

Metal wire has no modulus advantage over the bulk form of the material; however, composites that have higher tensile strength and improved creep strength compared to the matrix can be obtained by reinforcement with higher-melting-point wire materials. For example, stainless steel in aluminum or tungsten wire in superalloys can significantly increase creep properties of the matrix. Wire normally is produced by commercial wire-drawing processes. Research has centered on developing both higher strength wire by producing wire from stronger alloys, and improved wire-drawing techniques.

## 5. Ceramic Fibers

Continuous single-crystal alumina filament with tensile strength values approaching the average of whiskers has been grown from the liquid phase. Edge-defined-film-fed single-crystal  $Al_2O_3$  filament grown from a molten reservoir has been available commercially for several years and has been used for composite research studies. Another method for growth of single-crystal ceramic filaments is the floating zone method that uses a focused laser beam to melt the tip of a ceramic feed rod. A single-crystal seed rod of the same ceramic is carefully inserted into the molten drop at the tip of the feed rod and a single crystal is withdrawn at a controlled rate. Since no crucible is required and the laser can melt any ceramic of interest, a number of potentially promising filament compositions can be investigated. Process cost reduction is necessary before the filaments can be used in most metal-matrix applications.

### B. COMPOSITES

Based on laboratory data, some metal-matrix composites demonstrate properties superior to those of monolithic metals; however, relatively few systems have been studied in sufficient detail to characterize them adequately for design of hardware. Boron/aluminum has been fabricated into demonstration hardware for structures and gas turbine engines, additionally, portions of the NASA space shuttle structure are committed to B/Al tubes.

#### 1. Boron Aluminum

The largest body of data has been obtained for B/Al composites. Characterization design analysis, component fabrication process development, demonstration hardware production, and evaluation have been conducted for both airframe and engine applications. Fabricated components demonstrated weight reduction and performance improvements over the original monolithic component.

B/Al or silicon-carbide-coated B/Al composite is available commercially in a range of alloys, fiber contents, and sizes. Sheet or tape is the most common primary form of the composite. Figure 2 shows a schematic representation of three general fabrication methods. Diffusion bonding of either rolled foil or plasma-sprayed matrix is the method used for most monolayer composite production.

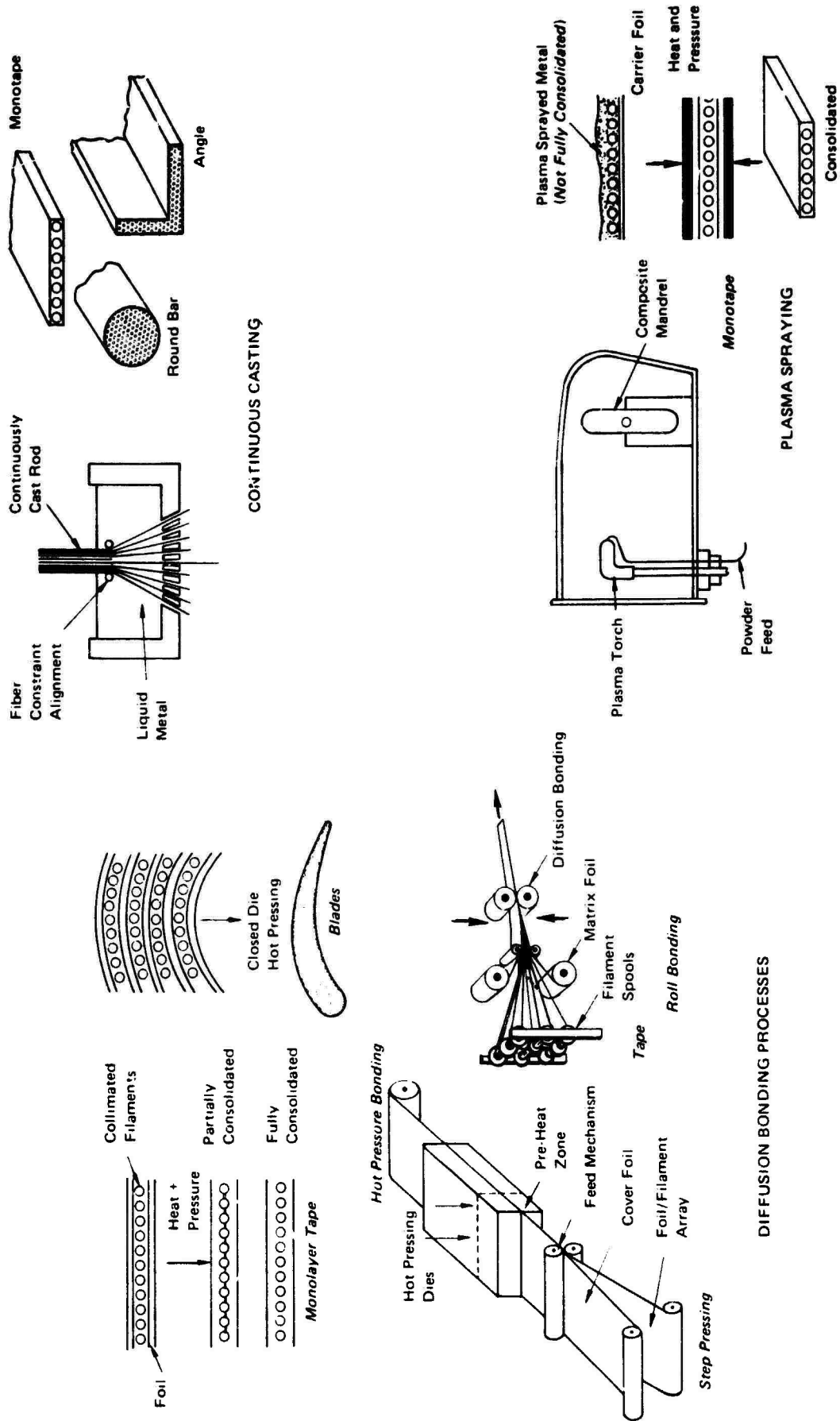

FIGURE 2 Schematic representation of three primary fabrication methods.

Continuous roll bonding of monolayer tape has potential as a high-production-rate, low-cost process. Typical properties for B/Al specimens are shown in Table 2 and, as can be seen, an increase in some property values has been achieved with 5.6-mil rather than 4-mil filament. Limited data for 8-mil boron-fiber composites show a further increase in properties. Since the larger-diameter fiber also is lower in cost and can reduce component fabrication costs, it is being chosen over the 4-mil fiber in many metal-matrix studies. Currently 5.6-mil boron is the most widely used filament.

Turbine engine fan blades and airframe structural components have been fabricated from boron/aluminum using an all composite structure and selective reinforcement. As indicated in subsequent sections of this report, the general results have been encouraging. Weight savings of from 30 to 40 percent over conventional construction have been obtained for structural components with equivalent or superior mechanical properties. Engine blades also have demonstrated increased tensile strength and stiffness with reduced weight; however, composite fan blade FOD resistance has been lower than required. While many of FOD requirements have been met, tests with larger birds such as ducks have resulted in considerable damage to blade airfoils. Current research suggests that, hopefully, impact strength can be increased to meet or exceed even the most severe engine requirements. This optimism is based largely on an order-of-magnitude improvement in Charpy test values; a correlation to FOD resistance has not yet been demonstrated. Airframe components have been technically successful; however, a further concern affecting application of composites, including boron/aluminum, is the relative procurement costs compared with current titanium blades or aluminum airframe components (see Chapter VIII).

## 2. Boron/Titanium and Silicon Carbide/Titanium

Titanium-matrix composites have been studied for a number of potential applications in aircraft engines and frames. The service conditions for which titanium-matrix composites are better suited are elevated temperature and high shear loading. Boron, silicon-carbide-coated boron, and silicon carbide filaments

TABLE 2 Typical Properties of Boron Aluminum<sup>a</sup>

Longitudinal Compressive Strength (ksi)	Longitudinal Compressive Strength (ksi) <sup>b</sup>	Longitudinal Elastic Modulus (msi)	Transverse Tensile Strength (ksi)	Transverse Compressive Strength (ksi)	Transverse Elastic Modulus (msi)	Calculated Density lb/in <sup>3</sup>
Rm. Temp.	500 °F	Rm. Temp	Rm. Temp	Rm. Temp	Rm. Temp	
	B/Al 6061	50 v/o	4-mil filament	unidirectional fiber plies:		
161	160	215	32	23	18	0.096
	B/Al 6061	50 v/o	5.6-mil filament	unidirectional fiber plies:		
215	180	623	33	108	20	0.094
	B/Al 2024	50 v/o	5.6-mil filament	unidirectional fiber plies:		
215	180		23			0.095

Note: Data from Advanced Composites Design Guide, Vol. IV, Third Edition, 1973.

<sup>a</sup> Unidirectional properties indicated. Actual application frequently requires cross-plying to secure adequate transverse properties, with concomitant reduction in properties along major axis.

<sup>b</sup> Results are sensitive to test method used.

are fabricated into titanium monolayer or multilayer composites by solid-state diffusion bonding techniques similar to those used for aluminum-matrix composites (Figure 2). Liquid-phase bonding is not used for titanium composites because of the ease with which reaction occurs at the fiber/matrix interface. Decreased matrix/fiber reaction can be obtained during fabrication or during long-time, high-temperature service exposure with silicon carbide or silicon-carbide-coated boron filament. Very short diffusion bonding times have been used to minimize reaction, and composites with good properties have been obtained.

Typical properties are shown in Table 3. Room-temperature longitudinal tensile values of about 180 ksi and longitudinal elastic modulus values of about 24 million psi have been obtained for a 50 volume percent fiber composite. The transverse strength of titanium may obviate the need for crossply fibers for some applications.

The upper temperature limit for silicon carbide/titanium in an air environment for long-time service is limited by matrix interstitial pick-up. While still in an early stage, research to overcome this deficiency using coating to minimize exposure to interstitials or using ductile, low-alloy-content matrix alloys offers the possibility to use titanium-matrix composites to 1200 °F for long-time service and to 1400 °F for short times. These temperatures are about 0.5 of the melting point, a homologous level that is consonant with structural strength.

Titanium-matrix composites are not as highly developed as aluminum-matrix composites and additional laboratory characterization data, simulated service experience, and structural component fabrication technique improvement determine their application areas.

### 3. Aluminum/Graphite and Magnesium/Graphite

The graphite/aluminum composite system has outstanding potential because of its low density and high specific modulus and strength. The incorporation of high-strength, high-stiffness, lightweight graphite fibers into aluminum makes an already useful engineering material especially attractive for use in service

TABLE 3 Typical Properties of Boron/Titanium and Silicon Carbide/Titanium

Material System	Density lb/in <sup>3</sup>	Test Temp. °F	Tensile Strength (ksi)		Elastic Modulus (msi)		Shear Strength (ksi)
			Longi.	Trans.	Longi.	Trans.	
B/Ti 3Al-2.5 Sn 50 v/o 4 mil boron uniaxial	0.128	Rm	180	66	35	26	--
SiC coated B/Ti v 6Al-4	0.130	Rm	190	75	36	29	72
50 v/o 4 mil B/SiC uniaxial		1,000	120	50	30	24	--
SiC/Ti 6Al-4 v	0.142	Rm	175	75	38	30	65
50 v/o 4 mil SiC uniaxial		1,000	150	50	32	25	38

Note: Data from references 2, 3, 6, 7, 23, 24, and 27. Undirectional properties indicated. Actual application generally requires crossplying to secure adequate transverse properties, with concomitant reduction in properties along major axis.

aircraft, missiles, and armaments. The low cost of aluminum and the projected drop in the cost of graphite fibers further enhance the potential of this system.

Recent studies supported by the Army Materials and Mechanics Research Center (AMMRC) have resulted in the development of a continuous liquid-metal infiltration process for making graphite/aluminum wire from commercial graphite yarns. The R&D achievements, based on a single program and limited data, are summarized in Table 4. Excellent bonding has been achieved between the fiber and the aluminum alloy matrix and between hot-pressed wires. Composite wire and hot-pressed bars made from this wire were found to have longitudinal tensile strengths and elastic moduli approximating Rule of Mixtures values. The improvements in strength and modulus over the unreinforced Al3 alloy are shown in Figure 3. The outstanding strength retention and specific strength of graphite/aluminum as compared to Fe, Ti and Al alloys are shown in Figure 4. Graphite/aluminum composites also have been made by hot pressing Al to G/Mg foils. Thus, the use of G/Mg provides an alternate method for fabricating graphite/aluminum and also has the potential for fabricating other composite systems such as G/Ti and G/Be. Titanium and beryllium sheet also have been laminated successfully to graphite/aluminum to form two new composite systems. The technology base now is being extended into the area of multiply, multidirectional layups for control of anisotropy and for the development of mill forms.

Potential applications of this composite system include missiles, aircraft, and armaments. Specifically, it includes the low-cost production of the following: (a) missile components--stiffeners, gyroscope gimbals, guidance and control surfaces, motor cases, pressure vessels; (b) helicopter components-- spars, skins, shafts, beams, stiffened transmission housings; and (c) armaments-- mortar and rocket launcher tubes.

Future R&D on this system includes development of an automated low-cost process for producing graphite/aluminum wire and tape, evaluation of graphite/aluminum wire and tape, improvement in transverse tensile strength of graphite/aluminum, the fabrication and evaluation of graphite/aluminum structures

**TABLE 4 Graphite/Aluminum Composites R&D Achievements**

<b>Process Improvements</b>	<b>Property Improvements</b>
Development of continuous liquid metal infiltration process for commercial graphite yarn	Tensile strength and elastic modulus of composite wire and bars reach rule of mixtures values
Production of continuous lengths of Al/G wire and tape	Reproducible properties of wires and bars
Fabrication of Al/G composite shapes and sheet	Full strength retention up to 400 °C
Fabrication of Ti-Al/G composite laminates	Specific strength at 400 °C 78% higher than Ti alloys
Development of Al/G composites using Mg/G precursor foils	Higher specific strength and modulus

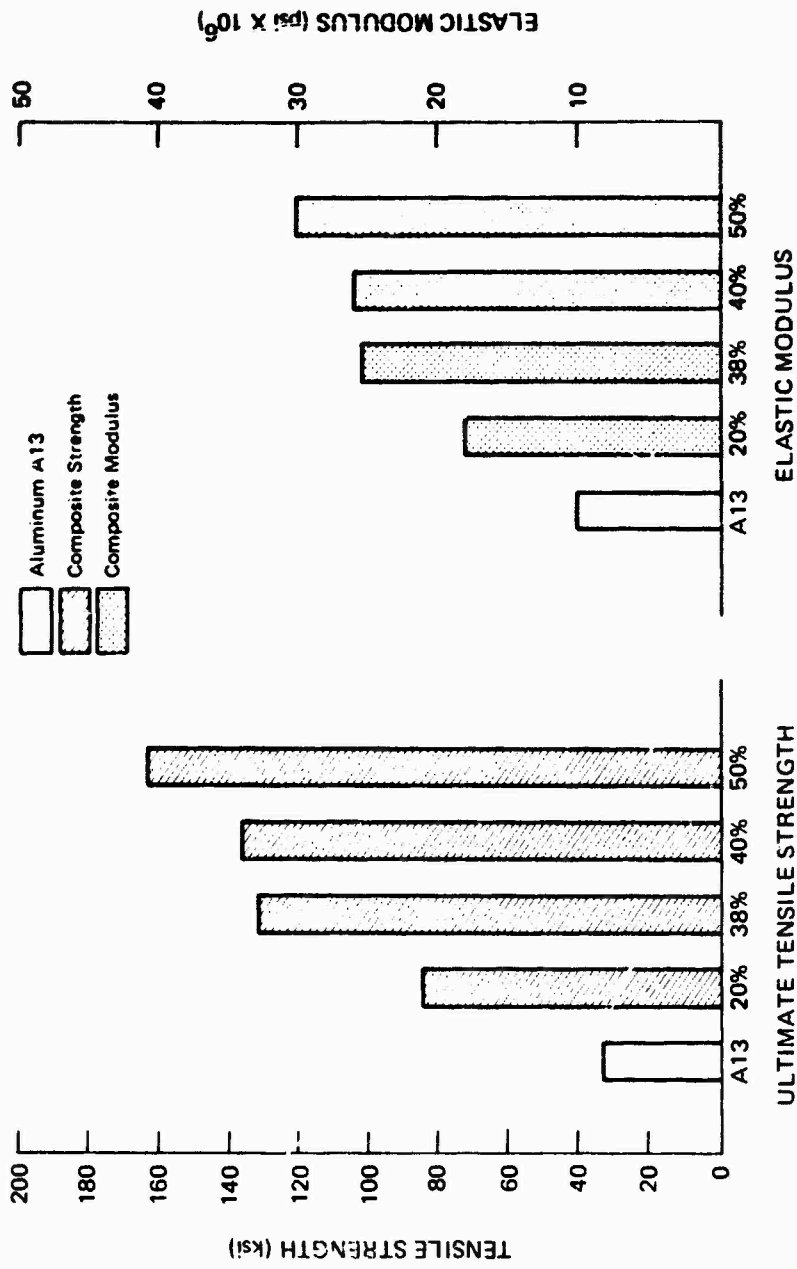

Figure 3 EFFECT OF GRAPHITE FIBER REINFORCEMENT ON ALUMINUM A13

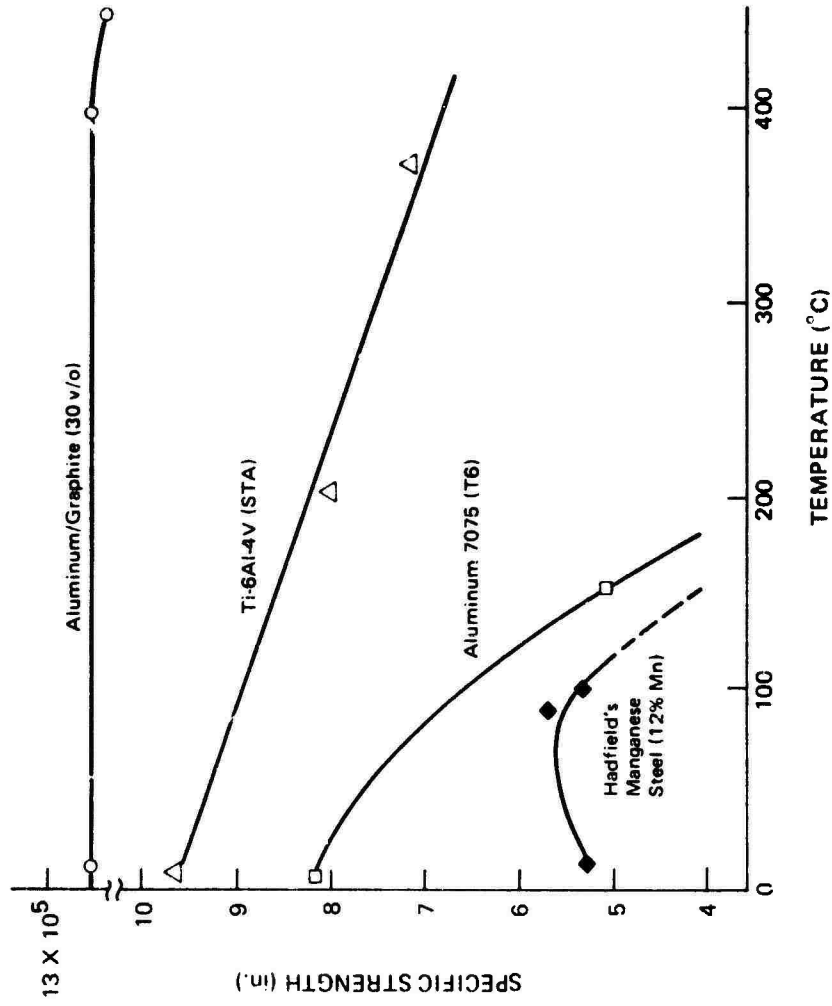

Figure 4 SPECIFIC STRENGTH VERSUS TEMPERATURE

including cylindrical forms for the design of aircraft and missile structures, and the development of improved G/Ti-Al and G/Be-Al laminates. Vigorous effort also will be directed toward exploiting the recent development of a very-low-cost graphite fiber mat from pitch (tensile strength of 200 ksi, elastic modulus  $30 \times 10^6$  psi, current price \$8/lb), thus opening up new opportunities for producing low-cost, high-strength, high-stiffness, lightweight graphite/aluminum extrusions that are randomly reinforced with these fibers. Potential applications include low-cost extrusions for service automotive vehicles.

Graphite/magnesium composites also have been successfully fabricated by drawing carbon fiber tows through molten Mg. The resulting composite has excellent properties that approach Rule of Mixtures values in tensile strength and exceed them in elastic modulus. At a fiber volume fraction of 40 percent a tensile strength of about 93,400 psi and an elastic modulus of  $27 \times 10^6$  psi were measured. Fractographic analysis of the broken tows indicated excellent wetting, infiltration, and bonding with negligible fiber pullout. Flat G/Mg about 1/2 inch wide also has been drawn from the melt.

This composite system is especially attractive for stiffening magnesium helicopter transmission housings thereby reducing gear wear and costly aircraft downtime. It also is attractive for applications requiring very high specific stiffness such as space vehicle structures, space antennae, missile structures, and missile gyroscope gimbals.

Future Army work on this system will be directed toward obtaining an extensive data base on its properties and exploiting the applications cited above. The possible corrosion behavior of graphite/aluminum and graphite/magnesium needs definition before the material could be considered acceptable for aircraft use. The alclad method of protection could be employed, if necessary.

#### 4. Beryllium/Titanium

Beryllium-reinforced titanium composites are produced by coextrusion of Be and Ti constituents in either powder (micro fiber) or wrought (macro fiber)

forms. The properties of the two types are sufficiently similar to allow joint discussion. These composites can be produced with beryllium volumetric contents ranging from 10 to 60 percent or greater.

Primary shapes such as angles, tubes, tees, zees, and hat sections can be obtained during the extrusion process. A beryllium-free titanium outer surface can be maintained to avoid loss of beryllium and to preclude corrosion from the graphite couple. The coextruded material, with properties as listed in Table 5, is available commercially from two suppliers.

#### 5. Superalloy-Matrix Composites

The primary application for superalloy-matrix composites is gas turbine blades. A significant performance increase and operating cost benefit can be gained by increasing the material operating temperature and stress of turbine blades and thus decreasing cooling-air requirements. Increased temperature capability from superalloy development is limited; therefore, several composites have been chosen for development as the next generation of turbine blade materials.

Directionally solidified composites (DSC) have been under intensive study to increase high-temperature strength. A NMAB committee on directional solidification recently issued a report (NMAB-301) summarizing the current status of these materials and estimated that DSC materials can increase the temperature capability at least 100 °F (40 °C) over the best conventional nickel- and cobalt-base superalloys. This committee also concluded that research and development work on alloy systems, oxidation protection coatings, joining, and inspection has been insufficient. The systems that have been characterized beyond the screening data stage are Ni, Ni<sub>3</sub>Al-Ni<sub>3</sub>Nb; Ni<sub>3</sub>Al-Ni<sub>3</sub>Nb; NiCoCr-TaC; NiTaC-13, and CoNiCrAl-Cr<sub>7</sub>C<sub>3</sub>.

Refractory-alloy-wire-reinforced superalloys also have been studied for high-temperature applications. Solid-state diffusion bonding and liquid-phase infiltration techniques have been used to produce composite specimens. Monolayer tape has been produced using techniques and equipment similar to that used for titanium-matrix composites.

TABLE 5 Properties of Be/Ti Extrusions

Property	Coextruded Power		Coextruded Be rod in Ti 6Al-4V <sup>b</sup>
	Average <sup>a</sup>	Lowest Highest	
V/%	40.2	38.0 43.0	28.0
UTS	Room Temp	155	110.0 R. T. Long.
	600°F	122	92.0 400°F Long.
	800°F	102	90.0 600°F Long.
Tension Elastic Modulus	25.2	24.8 25.7	73.0 R. T. Transv.
			25.0 R. T. Long.
Torsion	11		19.0 600°F Long.
% Elongation	5.1	4.1 6.7	
Density lb/in <sup>3</sup>	0.123		0.134
Impact Strength-ft-lb "V" notch Charpy	18		

Note: Another source reports that a 40 v/o Be/Ti composite has a yield strength variation of 61 to 93 ksi, UTS of 138 ksi, elongation 4.2 percent, a modulus of 23 million and a Charpy impact value of 7.5 ft-lb for an extruded powder composite.

<sup>a</sup>Data from Brush-Wellman. Properties determined on 337 individual test bars - recent improvements in process are expected to decrease the number of data points falling significantly below the averages.

<sup>b</sup>Data from Stusrud, R. W., et al, "Beryllium Reinforced Metal Matrix Composites Study Program," EDR 7581, Final Report, No. 00-19-71-C-0324, Detroit Diesel Allison Division, GMC, August 1972.

Laboratory test data have been obtained indicating excellent tensile and stress-rupture strength values. Density normalized 1,000 hour stress-rupture values at 2,000 °F (1090 °C) for tungsten fiber/superalloy composites were over four times those for conventional superalloys and over twice those for the best published values for directionally solidified eutectics. Further beneficial increases in the strength of refractory-wire superalloy composites are possible. The data suggest that refractory wire/superalloy composites have considerable potential for application to turbine blades at use temperatures to 2,200 °F (1200 °C); however, additional laboratory and simulated-service test data are needed to more fully characterize and evaluate the material. Oxidation- and thermal-fatigue-resistance data are particularly necessary to prove the potential for blade application. Refractory-wire superalloy is viewed as one that will allow increases in operating temperature.

Oxide or ceramic-fiber-reinforced superalloys are a third class of composite being studied for high-temperature service. The current research activity is to produce the data required for future development once the limiting problems are overcome. Single-crystal aluminum-oxide superalloys have demonstrated low strength values because of chemical attack of the fiber by matrix alloying elements. In addition, thermally induced stresses resulting from thermal-expansion mismatch between fiber and matrix have caused fiber fracture during composite fabrication. Current research programs for ceramic fiber-reinforced superalloys are directed toward the reaction and thermal-expansion-mismatch problems. Data also will be required to indicate the potential for FOD resistance before serious development activity can be undertaken. The single-crystal fibers currently used for this composite are produced commercially for research activity needs. Production rates are relatively slow and fiber unit cost is high. Composite properties suitable for application have yet to be demonstrated; thus, the composite must be considered for long-term future use.

### C. SUMMARY

A family of fibers with properties suitable for use in metal-matrix composites has been developed. Graphite, boron, silicon carbide, refractory alloy wire, and aluminum oxide filaments are available in the quantities needed for the applications or research activities currently contemplated. A considerable number of metal-matrix composite systems have been fabricated and tested and indicate excellent properties compared with competitive monolithic metals. Most of these have not been studied in sufficient depth to be considered beyond the demonstration or screening phase. Boron/aluminum has been studied more extensively than any other metal-matrix composite, and engine and airframe test articles have been fabricated and tested. Titanium-matrix and directionally solidified composites may reach the application stage in the near future. There appears to be no technical problem preventing consideration of these composites for application.

#### IV. FABRICATION

At present, an extensive capacity exists for fabricating most forms of metal-matrix composite. The primary emphasis has been placed on aluminum-matrix systems reinforced with boron, silicon-carbide-coated boron, and graphite. Titanium matrix systems reinforced with boron or silicon-carbide-coated boron also have been considered but their fabrication is discussed separately since the procedures are markedly different than those for boron or graphite-reinforced metals. The four basic primary fabrication processes presently being pursued are:

1. high-pressure concepts (pressures in excess of 1500 psi)
2. low-pressure concepts (pressures between 100 psi and 1500 psi)
3. brazing concepts (pressures from 1 psi to 300 psi, depending on molten metal flow) and
4. powder metallurgy/sintering processes (i. e. , as used for Be/Ti)

##### A. FABRICATION OF BORON OR GRAPHITE IN ALUMINUM TITANIUM OR MAGNESIUM

Presently available facilities for production of diffusion-bonded boron or silicon-carbide-coated boron in aluminum have a total combined capacity of approximately 40,000 pounds per year, which is much more than actual production. For titanium-matrix composites there is a capacity of approximately 10,000 pounds per year; for plasma-sprayed aluminum-matrix composites, a total capability of greater than 30,000 pounds per year exists; and molten infiltration processes using aluminum or magnesium matrices with graphite as well as boron-type reinforcements are in the developmental stage. For the graphite/aluminum composite systems, the production capacity to convert the molten infiltrated aluminum-graphite precursor rods into plate and shape forms is presently several thousand pounds per year.

Two items are scheduled for production runs. The space shuttle mid-fuselage section will use B/Al tube trusses to replace deep shear webs. This usage will require several thousand pounds of monolayer tape during the next three or four years. The second production usage involves bi-layer, uniaxial B/Al plate to reinforce a tennis racket. Exact quantities are not known for this application. Blade and vane developmental applications also have yielded several hundred parts of various design; however, none as yet have been advanced to production status.

The effective application of metal-matrix composites to real structures can be carried out in a wide variety of ways. For example, flat multilayer composite sheet can be purchased and hot formed to shape or monolayer tape can be purchased, cut to size, placed in a tool and brazed, eutectic bonded, or diffusion bonded into a finished part. Also, "green" tape\* can be cut to size and shape, laid-up, off-gassed to remove the fugitive binder, and diffusion bonded. The choice of technique to be used is dependent upon the desired size and shape of the finished part, production rate, loading, the availability to the company fabricating the part of various secondary processing equipment, and the economics involved.

Successful, high-performance, and highly efficient B/Al structures have been fabricated by high-pressure diffusion bonding with subsequent high- or low-temperature forming, spot welding, or mechanical fastening. Also structures starting with monolayer tape of either the diffusion-bonded or plasma-sprayed type have been consolidated by low-pressure, high-temperature brazing processes into finished articles. To date, most successful applications of brazing have been as secondary processes for attaching to substructures, etc. Titanium-matrix composites can be handled in basically the same ways as aluminum-base composites; however, typically higher temperature and/or pressures are required.

\* "Green" tape comprises filaments held on a "foil" matrix using fugitive resin or flame-sprayed metal.

For graphite/aluminum composite systems, the primary composite manufacturing step (to convert the graphite tow which has been previously molten-infiltrated with aluminum) can create simple flat plate, sheet, or rod or, via closed die consolidation, can result in simple shapes or parts being produced directly. Two basic diffusion-bonding concepts are presently being pursued: (1) solid-state bonding utilizing high pressure and moderate temperature, and (2) lower-pressure high-temperature liquid-phase bonding. A wide variety of hybrid reinforcements and various matrix alloys are presently being evaluated.

The basic forming, brazing, bonding, and welding of graphite/aluminum composites are essentially the same as for B/Al; however, so long as the fibers are not damaged, the cutting, drilling, punching, and other machining operations can be done in graphite-reinforced composites in the same manner as are done in the matrix itself, (i. e. , diamond-coated tools are not required for graphite/aluminum as they are for B/Al). This points out an advantage of metal-matrix composite systems over the resin-matrix systems--the applicability of existing metal working techniques, equipment, and facilities. For example, drilling (or punching on materials less than 0.1 in. thick) and roll forming into simple curves are also directly translatable to metal-matrix composites. This advantage, however, can be obtained particularly when the composite sheet can be used, such as in some spacecraft structures, in large pieces that require only simple bending and cutting to shape. If the product (e. g. , fighter aircraft) calls for small pieces of complex curvature metal-matrix composites may offer little if any advantage over polymer composites or monolithic structures. The economic impact can go beyond the immediate saving of tooling cost. Since most aircraft facilities today have extensive metalworking shops, little new equipment would be required if metal-matrix composites were committed to a production application. However, if resin composites were chosen, many aircraft companies would be required to invest in new tooling and in training programs.

In the area of engine component production, a major change in the philosophy of composite part production is required. Extensive and costly tooling and significant lead times will be required. In order to achieve competitive costs

with current aircraft gas turbine engine hardware, such as fan blades and vanes, component manufacturers will have to make the transition from expensive time-consuming hand operations to automation. As will be discussed in Chapter VIII, the techniques and tools that are required to volume-produce blades and vanes have been identified and, in some cases, already tried. When the time comes to reach a production status, however, delays will be encountered unless some advance thought is given the design and development of the numerical control machines, laser ply cutting, automated ply layup, and other techniques required to produce economically competitive parts. Although these techniques are not revolutionary, they will require an investment of time and money if they are to be fully developed for practical production application.

A recent production analysis on F-100 "spar-shell type" engine exit guide vanes showed that B/Al vanes fabricated by a short-cycle, high-pressure diffusion bond could be less costly and lighter than present "bill of material" titanium vanes. The basic processes required to manufacture these parts all have been demonstrated; however, to scale up a manufacturing facility for mass production requires a sizable capital commitment, which is presently under consideration.

Basically, the present total industry capacity to produce, fabricate (process into usable structure), and machine advanced metal-matrix composites exceeds demand. However, as larger production applications for metal-matrix systems are initiated (and several are presently being considered), demand will grow sharply resulting in sizable capital outlay requirements. In addition, more effort now on developing secondary processing would minimize problems in this area later.

#### B. FABRICATION OF BERYLLIUM/TITANIUM COMPOSITES

The beryllium/titanium system is a relatively new development in the field of composite materials. This composite material is not a metal/ceramic system like most of the others considered in this section; yet it is an anisotropic material and has high specific properties similar to other types of composite. Most of the

preceding comments on B/Al are applicable to the Be/Ti system, however, the following discussion is presented to consider some of the unique characteristics of this system.

An economical method of preparing composites by extruding beryllium and titanium powder mixtures (after suitable pre-treatment of the powders to enhance bonding) has been employed to produce composites with attractive mechanical properties. Coextrusion of rods of beryllium in titanium is an alternate production method. Conventional equipment is used for the primary extrusion and also for secondary fabrication operations such as machining, forging, rolling, drawing, and forming. Both beryllium and titanium powders currently are available commercially in major quantities and extrusion presses suited to producing Be/Ti composite extrusions are readily accessible. For these reasons major quantities of Be/Ti composites can be produced without long lead times or significant capital investment.

Bar stock also is producible by direct extrusion of canned powder blends. Typical uses would be precursor to machined components and forging input stock. The large number of Be/Ti interfaces in the mixed powder material means that hot working of these composites must be performed with greater care than with filamentary composites.

The technical procedure for making sheet and plate in Be/Ti involves making large thin-wall extruded tubes, splitting them longitudinally, "unwrapping" them into sheet, and further reducing their thickness by rolling.

The ductility of Be/Ti composites allows forming operations typical of those employed for monolithic metals. The forgeability limits of Be/Ti are not completely defined at this time; however, work to date is most encouraging. One example that can be cited is the successful forging of round bar stock into airfoil shapes typified by gas turbine fan and compressor blading.

Over 400 Be/Ti extrusion encompassing a wide range of volume fractions and process variables have been made and characterized to date. From this

experience confidence in the reliability of the process has been obtained. This is best illustrated by summarizing (Table 5) one year of experience by one company in making 16 40V<sub>f</sub> Be/Ti extrusions of various sizes.

With proper beryllium hygienic precautions, Be/Ti composites are readily machined using conventional tools and procedures. Turning, boring, milling, drilling, grinding, threading, etc., all have been performed with equal or greater facility than experienced with comparable operations in monolithic titanium.

### C. SUMMARY

#### 1. Boron-Fiber Reinforced Composites

- a. Production capacity far exceeds present demand but is insufficient for potential production application; plant and equipment expansion and mass production process development will be required to meet anticipated production requirements as they come to pass
- b. Structural and hardware fabrication technology has been demonstrated but further practical experience is required
- c. Existing metalworking machinery can be used at least to some extent, in fabricating metal-matrix composites
- d. Part size limitations are basically equipment and not technology-limited

#### 2. Graphite-Tow-Reinforced Metal-Matrix Composites

- a. Production capacity for specialized material and parts exists and is growing as usage requires; production levels may eventually be limited by availability of the molten infiltrated precursor tow
- b. Graphite/aluminum composite parts can be machined, punched, drilled, and cut on conventional equipment with standard tools--diamond coated tools are not required

- c. Simple structural shapes and tapered and/or curved parts have been fabricated directly (without a secondary process) with much greater ease than with other fiber-reinforced metal-matrix systems
- d. Part size limitations are basically equipment- and not technology-limited

3. Beryllium/Titanium Composites

- a. Production capacity is sufficient for present and anticipated production application
- b. Fabrication technology draws heavily on existing metal-working experiences
- c. As is true with other composites, part size limitations are basically equipment- and not technology-limited

Tables 6 and 7 indicate various manufacturing processes, their limitations, and their level of development for metal-matrix composites, in particular boron-reinforced aluminum or titanium.

TABLE 3 Primary and Secondary Fabrication (Based on Experience with Boron/Aluminum)

Technique	Relative Dev. Level	Fiber	Flat	Shapes Simple	"Best For"
High Pressure Diff. Bond	high	any	yes	yes	
Low Pressure Diff. Braze	high	any	yes	yes	
Low Pressure Braze	med.	coated	yes	yes	
Low Pressure Eutectic	high	any	yes	yes	
High Pressure Plasma Spray	high	any	yes	yes	
Low Pressure Plasma Spray	med.	coated	yes	yes	
Low Pressure Master Alloy	med.	coated	yes	yes	
Molten Infiltrate	laboratory	coated	strip or rod	long narrow	
Low Pressure CRB	low	any	yes	possible	simple forms
Creep Forming	med.	any			large radius, simple curvature
Roll Forming	low	any			surface of revolution
Autoclaving	production	any			simple structural shape
"Con-Brazing"	med.	any			simple structural shape
Welding	med.	any			complex airfoil shape
Closed-Die Consolidation	production	any			simple structural shape
Hot Forming	med.	any			simple structural shape
Brake Forming	med.	any			airfoil or surface of revolution
Braze in Die	low	coated			high production rate
Air Consolidation	med.	any			high temp. honeycomb structures
Brazing	med.	coated			

TABLE 7 Joining and Machining (Based on Experience with Boron/Aluminum

Technique	Relative Dev. Level	Fiber	Cost	Speed	Limitations
Resistance Welding	high	any			max. thickness joint $\frac{1}{2}$ "
Electron-beam welding	med.	any			E-B equipment size
Brazing	med.	coated			tooling, fit-up and temp. control must be precise
Diffusion bonding	med.	any			part warpage
Mechanical fasteners	high	any			edge pullout
Eutectic brazing	med.	any/coated			precise temp. control
Adhesive bonding	high	any			use temperature
Diffusion Brazing	med.	any			part warpage
Rotary Ultrasonic drilling	production		med.	high	
Diamond Plate drilling	med.		tools - high	med.	
High Speed Steel drilling	production		low	slow	
Sawing	med.		med.	slow	
Hole Punching	production		low	high	
Milling	dependent				
Turning	on tools				

TABLE 8. Summary of Hardware Fabricated from Metal-Matrix Composites

Item	Date Fabricated	Composite Material	Size		Weight		Weight Savings (%)	Test Results/Reference No.
			m	in	kg	lb		
Airframe								
Adapter	1968	B-Al	1.50 dia. x 1.05	69 dia. x 42	32.7	72.0	45	Failed at 133% design ultimate (200% limit)
F-111 Bulkhead	1969	Bs/C-Al	0.94 x 4.8	36 x 48			26	Failed at 130% of design limit
F-106 Access Door	1969	B-Al	0.31 x 0.28	12 x 11			20	69.1 flight hours - no failure
OV-10 Spacer	1971	B-Al	2.1 dia. x 0.4	84 dia. x 16	38.4	84.5	20	Tested to 160% of design ultimate - no failure
OV-10 Truss	1971	B-Al	2.1 x 0.75 x 0.75	84 x 30 x 30	22.7	50.0	51	Failed in Al to Al braze joint
Compression Panel	1972	B-Al-Ti	1.2 x 0.6	47 x 24	5.0	11.0	22	Tested at 600 °F., failed at limit load
S-3A Wing Box	1973	B-Al	0.75 x 1.3 x 0.17	30 x 52 x 7	26.0	57.0	25	Static tested to 150% design limit, plus fatigue tested to 5 lifetimes
Space Shuttle Shear Beam	1973	B-Al	1.0 x 0.96	10 x 34	35.4	78.0		Failed at 106% of design ultimate
Space Shuttle Compression Panel	1973	B-Al	2.0 x 0.7	80 x 29	20.2	44.4		To be tested at 600 °F
Wing Compression Panel	1973	B-Al, Bs/C-Al	0.36 x 0.6	15 x 24	3.0	6.5	35	Failed at 210% design limit
Space Shuttle Panel	1973	B-Al	1.2 x 1.8	18 x 72	13.6	96.0	25	To be tested
600 °F Luggage	1973	Be-Ti	0.35	14				No tests
Box Beam	1973	B-Al, B-C, B, Ep	6 x 3.5	294 x 97	70	153.6	31	Failed at 150% design limit
Engine Components								
F-100 3rd Stage Fan Blades	1971	Bs/C-Al	0.25	10 span	0.10	0.23	38	72 mig. rig tested
F-100 1st Stage Spar Shell								266 Mfg., rig tested, failed engine test
Fan Blades	1972	Bs/C-Al	0.27	10.9 span	0.32	0.70	30	Passed 122% speed, 500 °F test; failed FOD test
J-79 1st Stage Compression Blade	1973	B-Al	0.05 x 0.26	2.2 x 10.5	0.16	0.35	65	266 Mfg., 564 engine test hours
TF-30 3rd Stage Fan Blades	1971	Bs/C-Al	0.25	10.0 span	0.19	0.41	40	80 Mig., full set (30 blades) tested for 3 hrs.
JT-3D 1st Stage Fan Blades	1968	Bs/C-Al	0.34	13.5 span	0.45	1.06	40	Passed rig test, erosion & limited FOD
APSH Fan Blades	1972	B-Al	0.1 x 0.18	1 x 7	0.14	0.30	60	
TF-41 Fan Blades		Be-Ti						
F-100 1st Stage Vanes	1972	Bs/C-Al	0.25	16.0 span	0.18	0.385	40	180 Mig., 218 engine hrs. on 1 set (52 blades)
DLG Fan Blades	1970	B-Al	0.09 x 0.25	3.5 x 10.0	0.25	0.56		Passed rig test, erosion & limited FOD
Other								
Cambal Ring Stiffeners	1971	Bs/C-Al	0.21 x 0.04	5.3 dia. x 3.5	1.6	3.5		Two rings tested-no failures
Stiffener Ring for 155 mm Artillery								
Projectile Retainer	1972	Bs/C-Al	0.13 x 0.08	1.36 x 0.46	6.7	1.55	65	Four test firings-no failures
Racing Auto Valve Spring	1973	Be-Ti	0.03 x 0.01	2.23				Performed without breakage in race usage
Racing Auto Intake Valve	1973	Be-Ti						To be tested
Value Spring Demonstrator	1973	Be-Ti						Satisfactory in trial
High Speed Machinery Cams and Fasteners	1973	Be-Ti						Passed operating, corrosion & mechanical abuse test
High Speed Rawind Mandrel	1973	Be-Ti	2.7 x 0.05	108 x 2.2				

## V. SUMMARY OF HARDWARE BUILT

A number of hardware items have been fabricated from advanced metal-matrix composite materials. These include airframe test articles, engine components, and other applications that take advantage of the high specific strength and modulus properties and superior fabricability of metal-matrix composites. A summary of the known metal-matrix composite hardware fabricated to date is given in Table 8.

Over 20 major pieces of airframe hardware have been fabricated from metal-matrix composites in sizes ranging up to 7 feet in diameter and up to 9 feet in length and weighing as much as 96 pounds. Weight savings over conventional structural materials have ranged from 20 to 56 percent. Nearly all of the metal-matrix composite airframe items were tested with satisfactory results. Structural testing of metal-matrix composite hardware has included static and dynamic tests and, in one case, actual flight testing.

A variety of manufacturing methods were used to fabricate the structures from boron/aluminum, boron/titanium, and beryllium/titanium. The methods have included forming (both hot and cold), machining (abrasive cut-off, diamond cut-off and drilling, and rotary ultrasonic), and joining (including brazing, diffusion bonding, adhesive bonding, riveting, mechanical fasteners, resistance welding, and combinations of these methods).

Typical examples of some of the metal-matrix composite structures include a 5-foot diameter by 4-foot high space payload adapter built for the Atlas launch vehicle (Figure 4). The 40 stringers were fabricated by hot forming of beryllium/aluminum, the skins were roll formed, and resistance welding and riveting was used for joining. The structure was successfully tested to 200 percent of design limit load before failure.

Metal-matrix composite blades and vanes for aircraft engines have been successfully engine tested. However, these items, so far, have not passed all FOD tests.

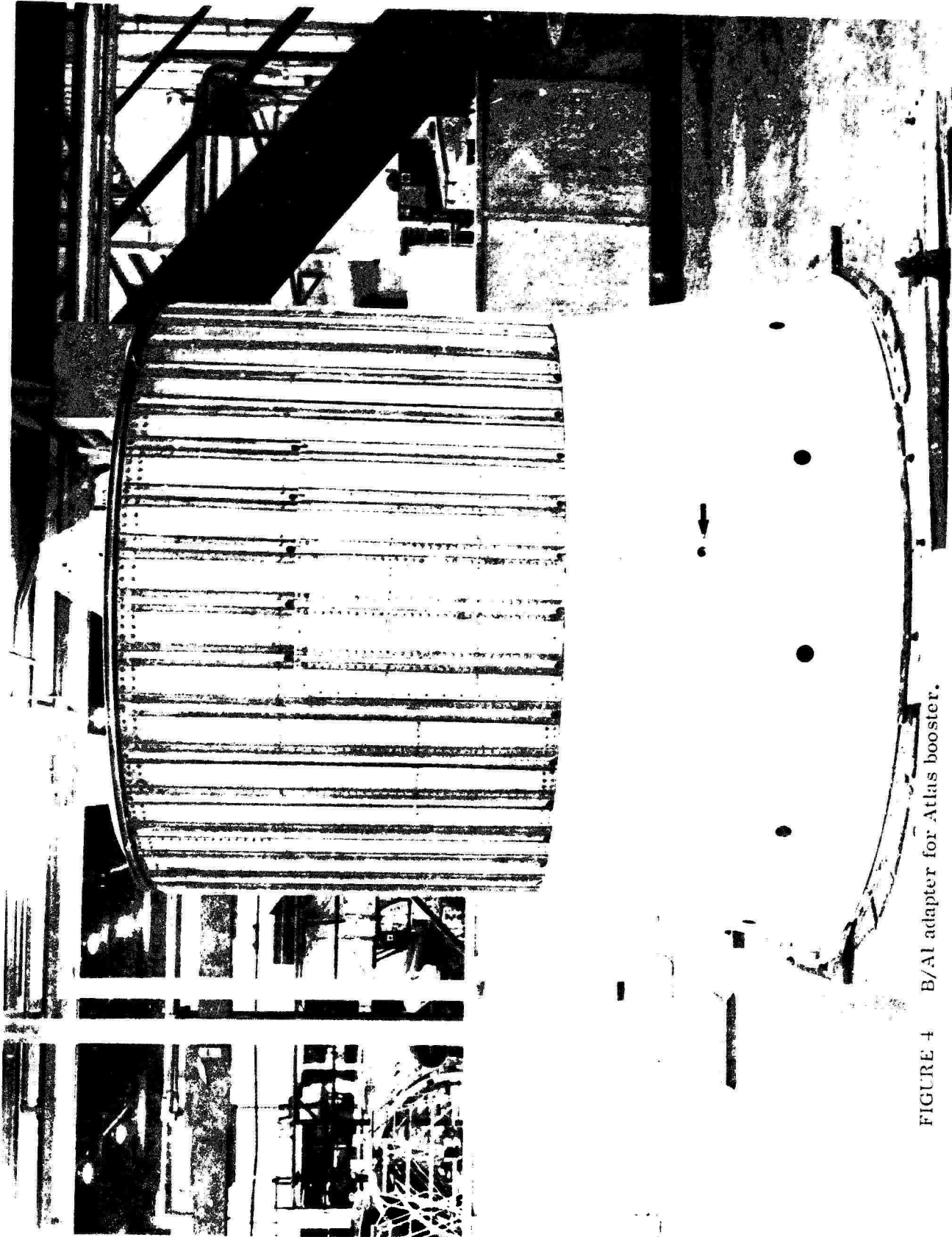

FIGURE 4 B/AI adapter for Atlas booster.

Another assembled structure was a 3 foot by 4 foot bulkhead for the F-111 fuselage (Figure 5). This all heat-treated B<sub>SiC</sub>/Al structure used Z and T stiffeners mechanically fastened to a cross-ply web. A 1 foot by 1 foot beryllium/aluminum access door (Figure 6) has had almost 70 hours of flight time.

In a Grumman program, a composite box beam was designed, built, and tested (Figure 8). The baseline box represents a wing structure of an advanced, variable sweep, supersonic fighter aircraft. The 43-square-foot structural box functions as an integral fuel tank with operational surface temperatures of 350 °F (177 °C). It includes provision for mounting slats, flaps, spoilers, handholes, fuel system and an external store station. The optimum design from the standpoint of weight was a five beam, five rib graphite/epoxy substructure with mechanically fastened boron/aluminum honeycomb sandwich upper and boron-graphite/epoxy hybrid plain panel lower covers. Cover material selection was predicated on comparisons of the specific strengths of the available composite and metallic materials for the design temperature of 350 °F (177 °C). Graphite/epoxy was selected as the material for the substructure because of its ability to form integral web-cap channels. The selected organic-matrix composites consisted of 350° F-stable epoxy-resin systems. The graphite and boron reinforcement selected were continuous length Type A-S fiber and 4.0-mil-diameter filament, respectively. Both the boron/epoxy and graphite/epoxy systems were supplied as 3-inch continuous tape which, when autoclave molded, produced laminates of nominally 52.5 and 60 percent, respectively, fiber content by volume. The selected boron/aluminum consisted of stepped press diffusion bonded 6061F aluminum foil, free of additives or brazing foil, and 5.6-mil-diameter boron filaments at a volume fraction of 45 to 50 percent.

The demonstration wing component was designed, fabricated, and delivered to the Air Force Flight Dynamics Laboratory where it was subjected to static test. The static test consisted of the sequential application of a series of preliminary test conditions followed by the application of limit and ultimate load for the four

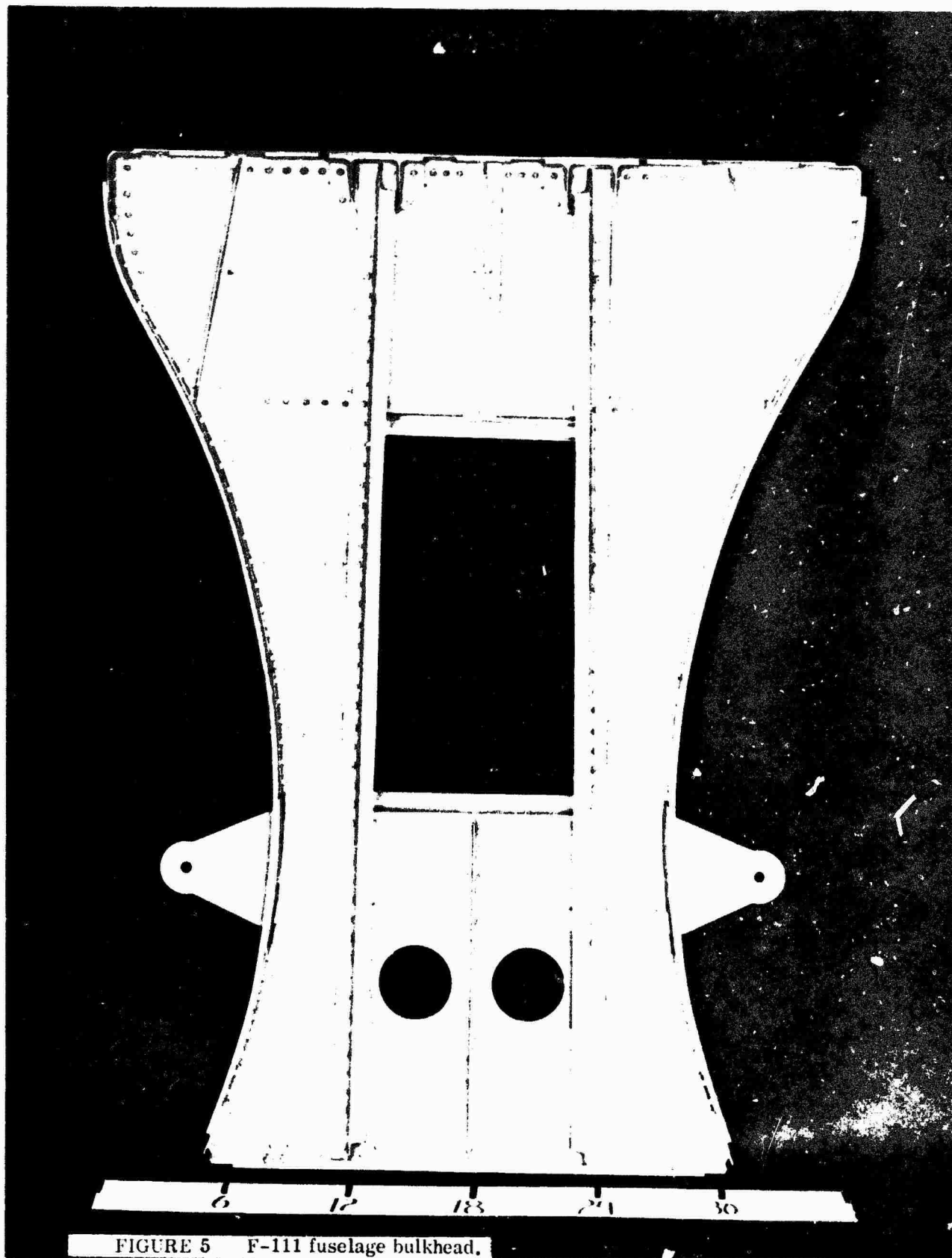

FIGURE 5 F-111 fuselage bulkhead.



FIGURE 6 F-106 flight test of B/AI access door.

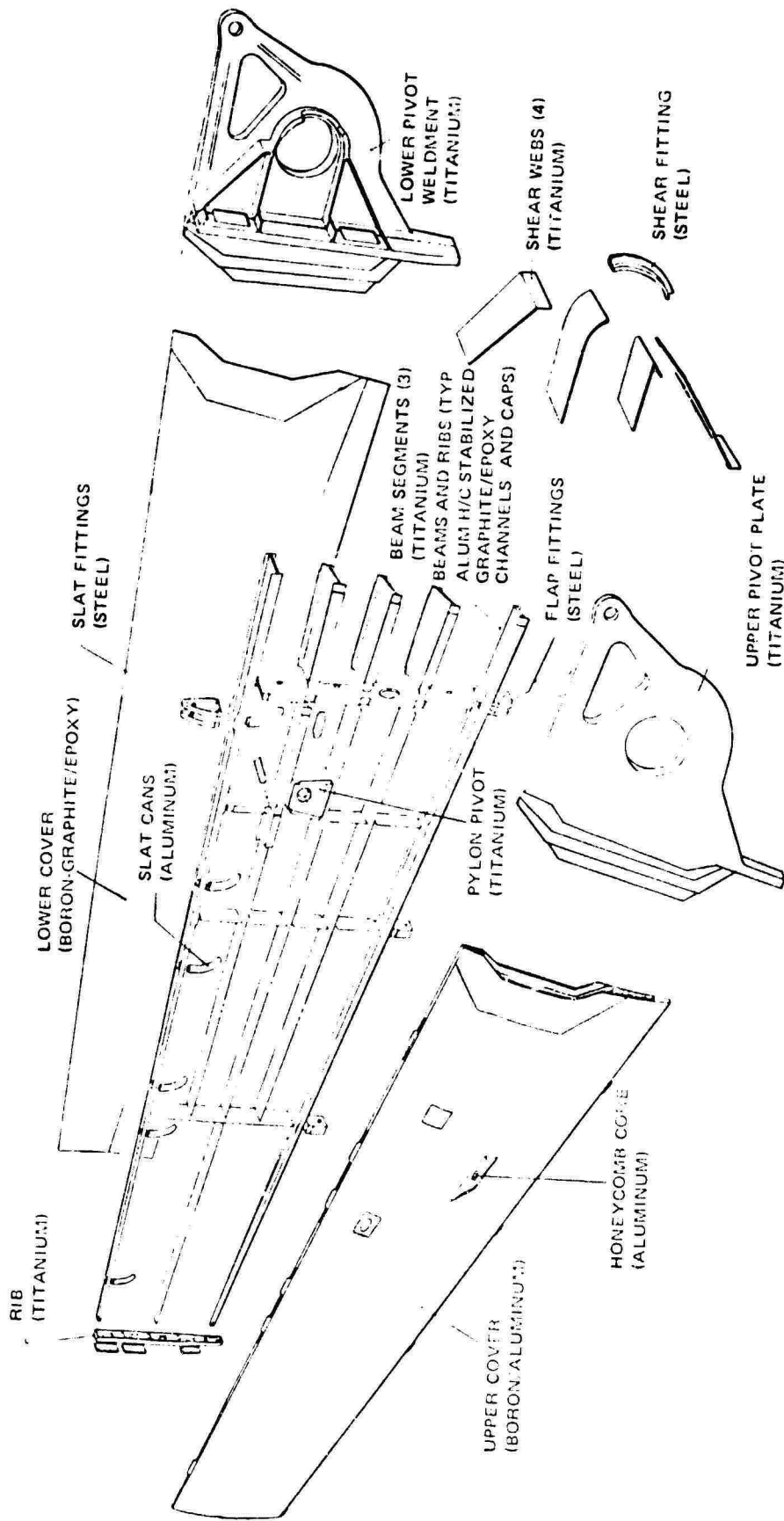

Figure 7 Selected Grunman composite wing configuration.

critical load conditions. Leakage and localized overheating during the preliminary pressure test and temperature survey, respectively, and an initial failure of the B/Al upper cover at limit load of the subsonic roll maneuver resulted in changes in the test conditions and sequence. These changes included omission of temperature during the supersonic loading conditions and pressure during the subsonic roll maneuver. Without repair the component successfully withstood application of 150 percent limit load for the negative supersonic pull-up condition. Failure occurred in the B/Al cover during the critical positive subsonic pull-up maneuver condition at 130 percent of the design limit load.

Weight savings, including the pivot, of 30.8 percent over the baseline titanium wing was achieved by the optimized composite wing design. This would be increased to a 46.2 percent saving over an aluminum baseline wing. Total wing weights are 2220-pounds in titanium, 2854-pounds in aluminum and 1536-pounds in the optimized composite wing. Excluding the pivot and relative to the titanium design the upper cover weight savings is 50.6 percent, the lower cover savings is 58.0 percent and the substructure saving is 44.0 percent.

A wing box for the S3A aircraft is shown in Figure 8. This structure, built for the Navy, has surpassed all design requirements. After successfully completing testing at 150 percent of design limit load in bending, torsion, and internal pressure, the box was fatigue tested for five 6,000-hour life cycles without failure. A 40 inch by 40 inch B/Al shear beam, shown in Figure 9, was built for NASA-MSFC to demonstrate the applicability of B/Al for the space shuttle. The beam consists of 0.20-inch thick heat-treated B/Al web, 22 Con Braz joined I-section stiffeners, and a tapered B/Al compression cap. The panel was assembled using resistance welding and mechanical fasteners. Holes for the rivets were made using the rotary ultrasonic drill (for thick sections) and hole punching (for sections under 0.1 inch thick). The shear beam was tested to 106 percent of design requirements before failure.

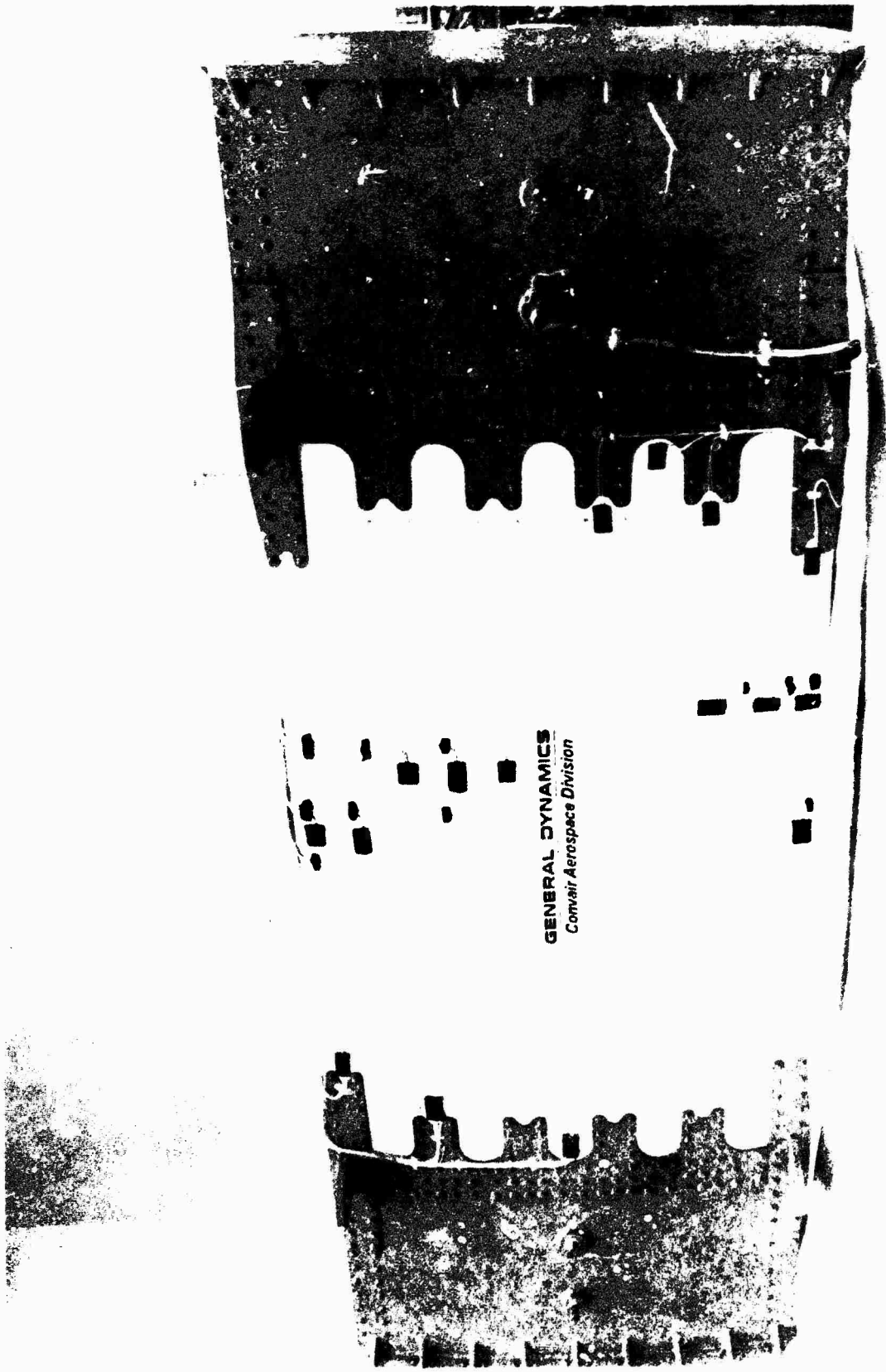

FIGURE 8 B-47 wing box.

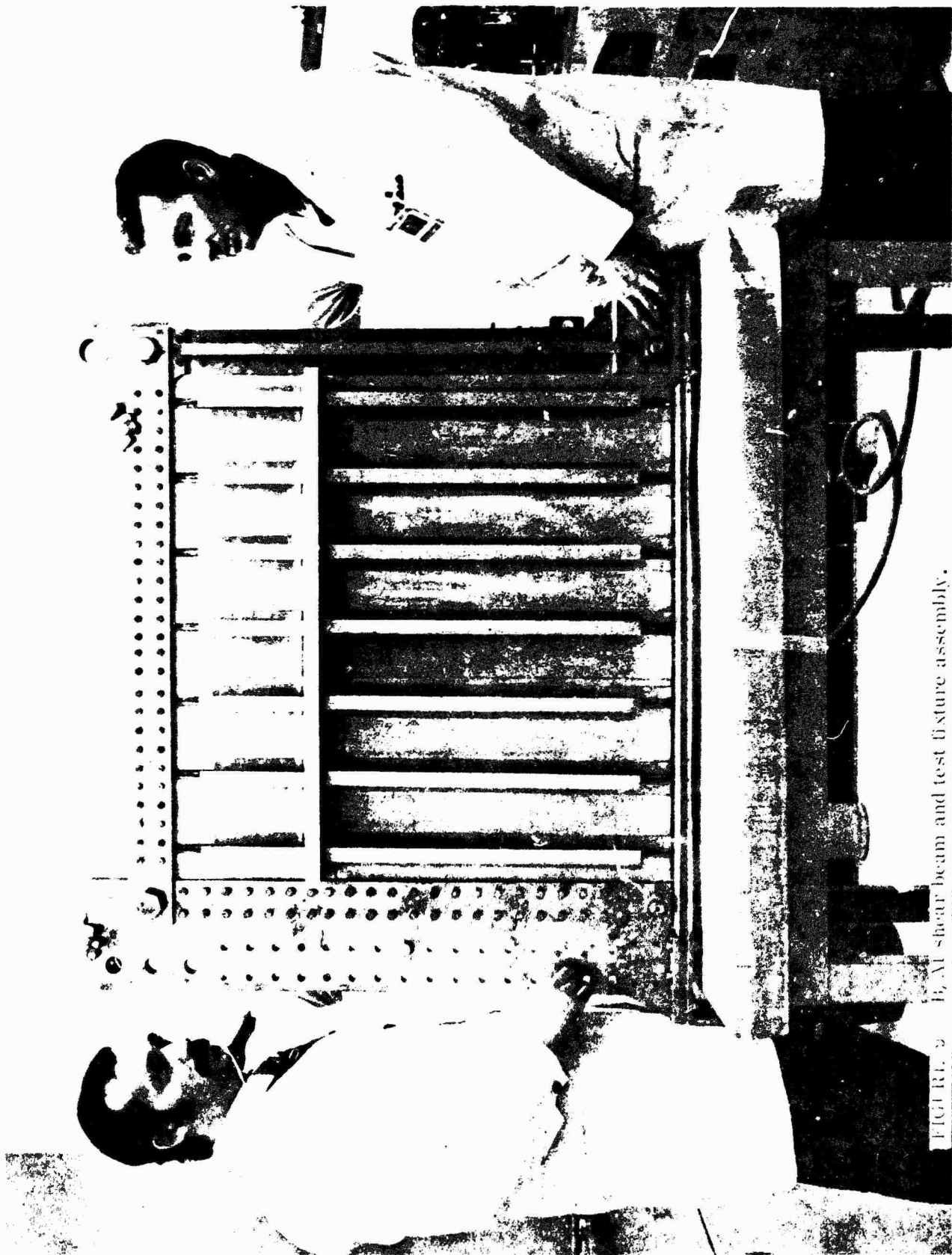

FIGURE 2. B-1 shear beam and test fixture assembly.

A basic list of specific advantages and disadvantages of metal-matrix composites in comparison with conventional current materials is presented in Tables 9 and 10. The locations in engines where composites might be used are shown in Figure 15. Specific quantification of the benefits or losses based upon these areas cannot be included because they depend upon specific design application and the extent of redesign or original design using composites that would be applied.

**TABLE 9 Metal-Matrix Composites: Advantages and Disadvantages in Engines**

Component	Conventional Mat'l Temp	Composite Material	Advantage (A)/Disadvantage (D)	Comment
Fan blades	Titanium 300 - 600°	B/Al, B/Ti Be/Ti	Higher strength density (A) Higher modulus density (A)	Lower weight, Higher tip speed = better performance 1. direct substitution 2. reduced number of blades 3. Reduced number of stages 4. Elimination of shrouds
			Lower transverse strength (D)	FOD capability reduced Protection required
			Reduced surface toughness (D) Improved damage isolation (A)	May require erosion protection Crack propogation reduced due to fiber construction
			Fatigue strength vs. Ti (A)	
			Less secondary damage (A)	FOD to downstream parts less catastrophic
			More difficult to inspect (D)	Requires more sophisticated inspection techniques
			More difficult to repair (D)	Requires special techniques
Fan Vanes	Titanium 300 - 600°	B/Al, B/Ti Be/Ti	Higher strength density (A) Higher modulus density (A)	Lower weight only By direct substitution
Compressor Blades and Vanes	Titanium 500 - 800°	B/Al, B/Ti Be/Ti	Higher strength density (A) Higher modulus density (A)	Lower weight by direct substitution and reduced number of blades
Fan/Compressor Disks	Titanium 300 - 800°	B/Al, B/Ti Reinforcement	Other Advantages and Disadvantages for Blades Apply	Blades Apply
			Higher strength density (A) Higher modulus density (A) More difficult to Inspect (D)	Lower weight by reinforcement at rim Requires more sophisticated inspection techniques
Fan Ducts	Titanium Sheet/ Honeycomb 300 - 700°	B/Al, B/Ti	Higher strength density (A) Higher modulus density (A)	Lower weight, more efficient structures
			Damage isolation (A)	Crack propogation reduced due to fiber construction
			Fatigue strength (A)	
			More difficult to Inspect (D) More difficult to repair (D)	Similar to Ti honeycomb, requires sophisticated techniques Similar to honeycomb, requires special techniques
Turbine Blades	Cast Superalloys 1100 - 1800°	Eutectics, Reinforced Ceramics, Reinforced Superalloys	Higher properties at elevated temperatures (A)	Improved performance, higher allowable temperatures
			Lower impact strength (D) More difficult to fabricate (D)	FOD or handling problems May require attached root and platform rather than one piece casting

A high-temperature (600 °F) compression panel was also built for the Space Shuttle and is shown in Figure 10. This 7-foot long panel consists of B/Al stringers that were formed at room temperature using the Con Clad process. Joining of the stringers to the cross-plyed B/Al skin was accomplished by resistance spot welding. Subcomponent tests on this structure have indicated excellent load carrying capabilities at 600 °F. Another high-temperature compression panel fabricated from low-pressure-bonded B/Al stringers mechanically fastened to B/Al sheet is shown in Figure 11.

The mid-fuselage of the space shuttle is comprised of a truss of tubing. The material has been designated ("base line") as B/Al. 100 tubes have been built and tested, and 1800 tubes will be fabricated. This application is cost-effective since the value of a pound saved is about \$1000.

Figures 12 through 14 show examples of engine hardware fabricated from advanced metal-matrix composites. A JT8D first-stage fan blade fabricated from B/Al and one from conventional material is shown in Figure 12. Figure 13 compares a complete first stage fan for the JT8D engine made from B/Al with one made from conventional titanium construction. The B/Al guide vane development was a technical success. The product is ready for qualification, but is not being introduced because the cost is still greater than that of the conventional Ti blade. Figure 14 shows a TF-41 LP3 compressor blade made from beryllium/titanium composite. In the case of Be/Ti composites, the materials are too new to have received aerospace application and test scrutiny as major assemblies. Currently, several items of aerospace hardware incorporating Be/Ti are in the fabrication-testing phase (Figure 15). Several Be/Ti parts have been evaluated in commercial markets (Table 8); these parts include machined components for racing automotive-type engines, high-speed machinery cams and fasteners, and high-speed shafting for commercial machinery.

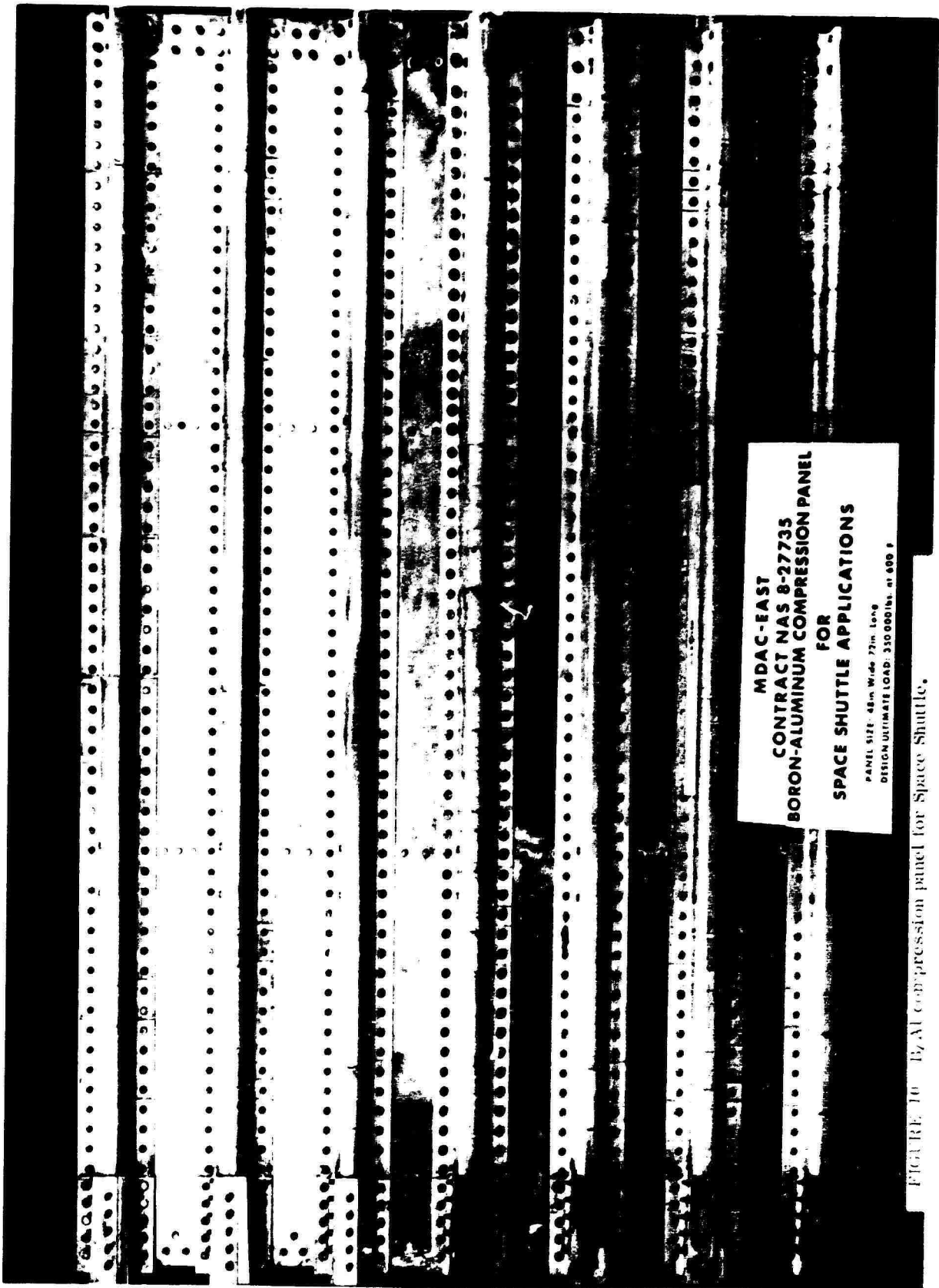

**MDAC-EAST**  
**CONTRACT NAS 8-27735**  
**BORON-ALUMINUM COMPRESSION PANEL**  
**FOR**  
**SPACE SHUTTLE APPLICATIONS**

PANEL SIZE: 48in Wide 72in Long  
DESIGN ULTIMATE LOAD: 350 000lbs. at 400 F

FIGURE 10 - B7A1 compression panel for Space Shuttle.



FIGURE 11 — B. Al 7-1691 compressor, mach.

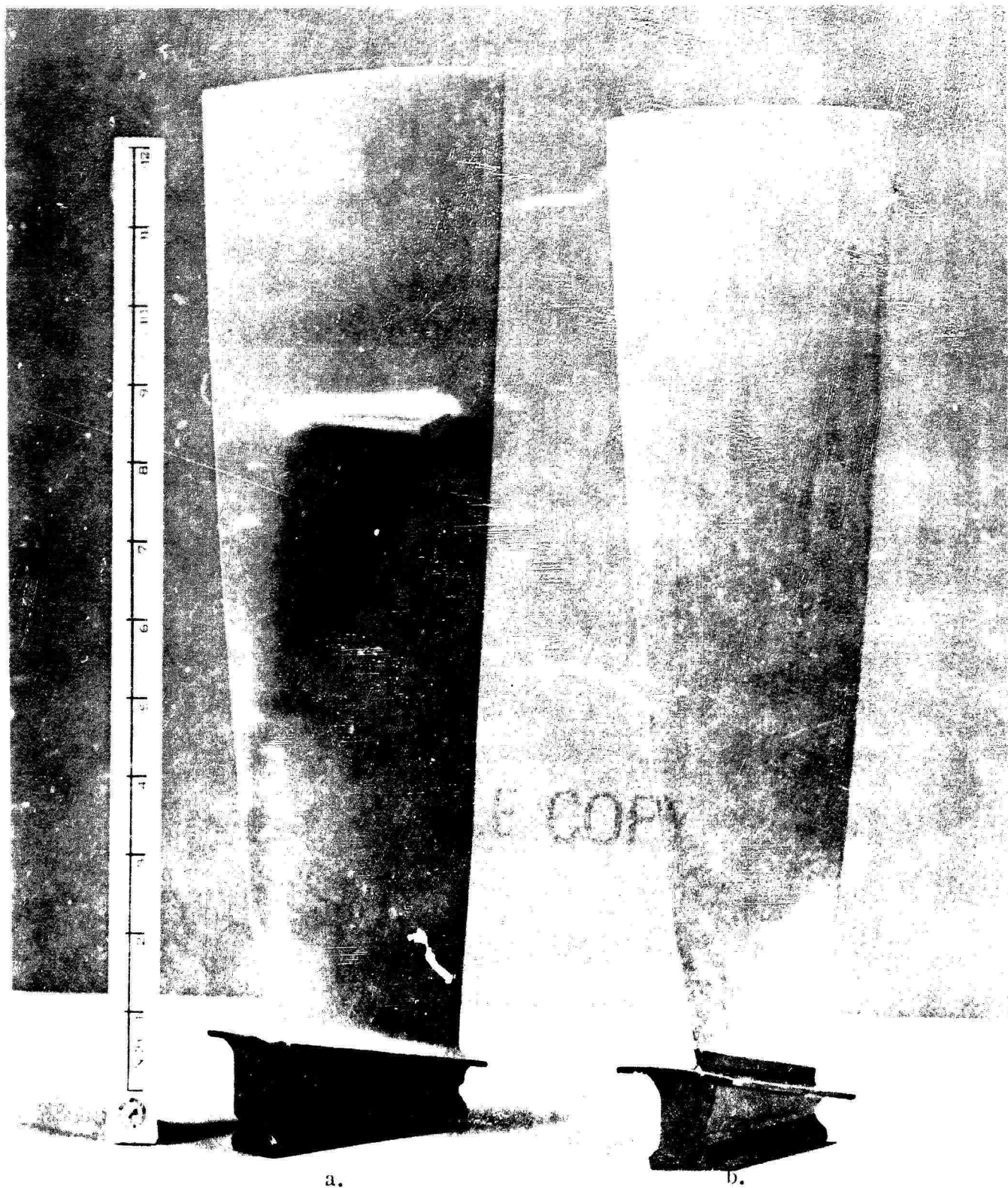

**FIGURE 12** JT8D commercial transport engine first-stage fan blades:  
(a) conventional titanium blade with midspan shroud and  
(b) experimental borsic aluminum blade

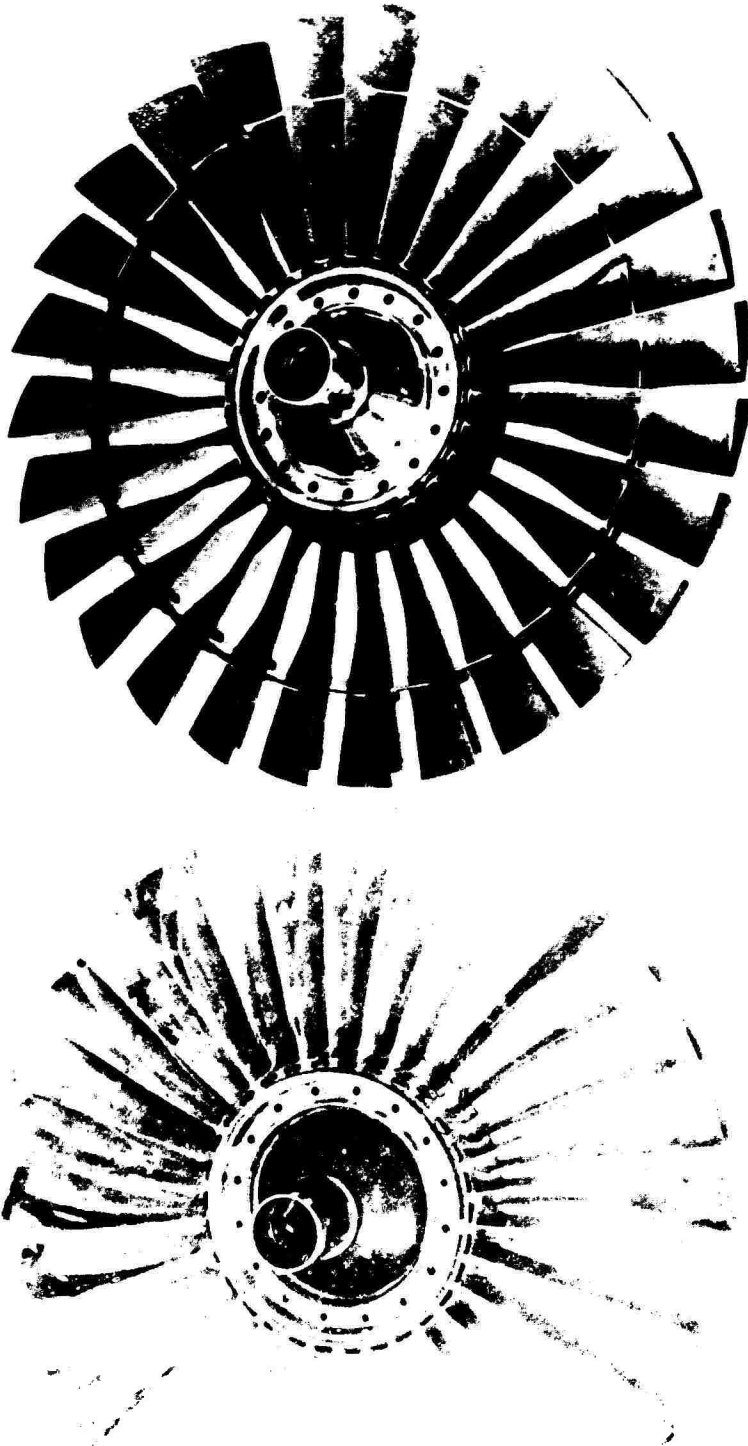

FIGURE 13 JT8D commercial transport engine first-stage fan blades:  
(a) experimental boric/aluminum without midspan shrouds  
and (b) conventional titanium blades.

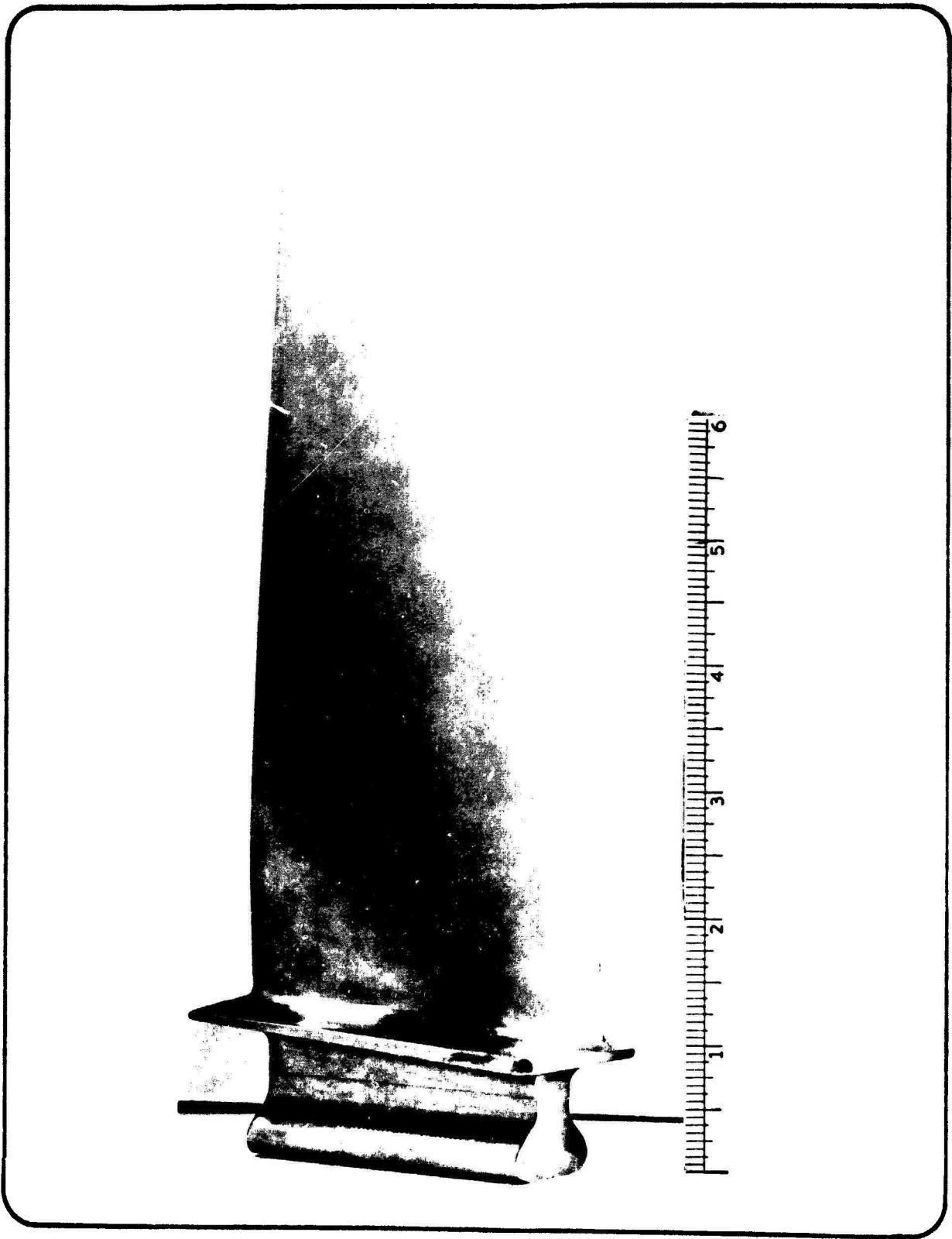

FIGURE 14 TF-41 LP3 compressor blade, beryllium-titanium composite.

# PROPULSION SYSTEMS

## APPLICATIONS

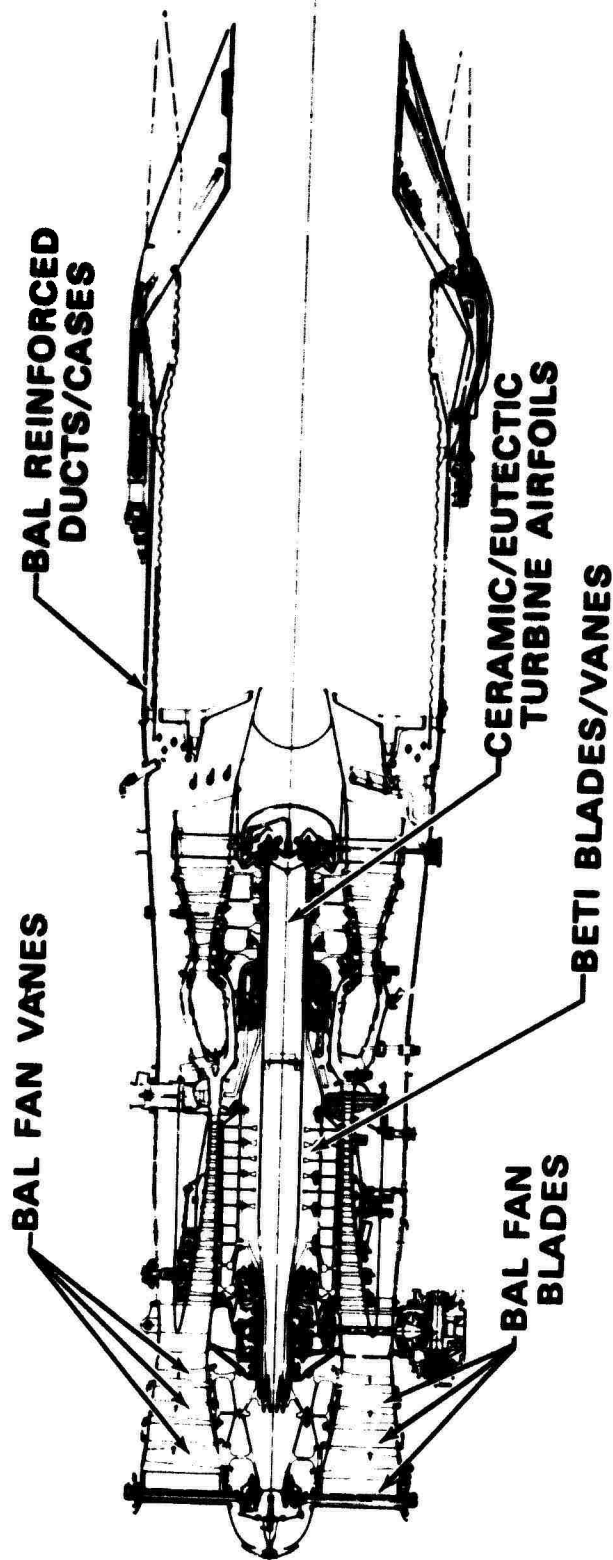

Figure 15 Propulsion systems applications.

FD 71046  
730405

## VI. ADVANTAGES AND DISADVANTAGES OF METAL-MATRIX COMPOSITES

Metal-matrix composites represent an attractive candidate material system for airframe and engine applications because of their high elastic modulus and strength and low density. The requirements for improved performance and, particularly, higher thrust-to-weight ratio in aerospace applications has resulted in the introduction and use of high-strength and -density materials such as titanium. A comparison of strength/density and modulus/density for a typical metal-matrix composite, B/Al, and the most widely used competitive metal alloys is as follows:

	<u>Titanium</u>	<u>Aluminum</u>	<u>Stainless Steel</u>	<u>B/Al</u>
Modulus/Density	0.326	0.341	0.385	1.0
Strength/Density	0.417	0.218	0.402	1.0

Fatigue strength of composites is also advantageous. A principal advantage to the engine designer inherent in composites is that they give the designer the ability to adjust or specify the orientation of fibers to the principal axis of stress. This allows the designer, for the first time, to design the material for the application. In parts subjected to vibration, he has the ability to "tune out" harmful natural frequencies within the same physical envelope by adjusting fiber orientation. At the same time, it would be costly to build in a midspan shroud should this be needed to damp vibrations.

Problems related to the application of metal-matrix composites are primarily those resulting from lack of experience and confidence as well as current costs. These include costly fabrication techniques that can be used in manufacture and in the field, repair or overhaul provisions, and specific application problems such as foreign object damage and erosion in engine fan components.

Fabricating beryllium/titanium calls for the hygienic precautions needed for using beryllium in any form. The additional ventilation, sampling, and health check add to the cost. An emotional reaction to the use of beryllium must always be coped with.

TABLE 10 Metal-Matrix Composites: Advantages and Disadvantages in Airframes

Component	Conventional Mat'l/Temp	Composite Material	Advantages (A)/Disadvantages (D)	Comment
Cover skins: wings, stabilizers control surfaces fuselage, doors	Aluminum (300 °F) Titanium	BA1 (R. T. 600°F) BT1 (R. T. 1,000°F) BeTi (R. T. 1,000°F)	Higher strength density (A) Higher modulus density (A)	Lower weight, better performance increased flutter speeds, increased compression and shear stability
Inlet structure: ramps, liners			Require special techniques (D) High cost (D)	
Substructure: spars, stiffeners, longerons, formers frames, bulkheads, intercostals				Lower weight, better performance increased compression and stability
Other: spindles, torque tubes, landing gear, arresting hooks				Lower weight, better performance increased compression, torsion and fatigue

## VII. COMPONENTS AND SYSTEMS FOR WHICH METAL-MATRIX COMPOSITES ARE CANDIDATES

The identification of potential components and systems for which metal-matrix composites are candidates is certainly possible. However, whether the projected applications are eventually realized depends on a number of factors and these are valid for any new material. The most important of these factors are:

1. That selection of technology initially should be based on cost-effectiveness (i. e. , \$/lb saved, impact on configuration, mission, etc.) and not only on cost-competitiveness (i. e. , first cost)
2. That new materials should not be introduced only by the substitution process that frequently prevails; however, substitution is a procedure enabling confidence to be more rapidly acquired.

An example of the first factor is the account of boron/aluminum diffusion bonded to reinforce selectively a titanium B-1 longeron, presented at the 1973 Advanced Composites Status Review. It was stated that the hybridized structure was cost-effective but not cost-competitive. While there are cases in which beryllium/aluminum would be cost-competitive today, for this composite to be widely accepted, its use must be justified on the basis of life-cycle costs and, preferably, also its impact on vehicle configuration achieved at the preliminary design level.

The second factor is important when, for example, the broad range of advantages of boron/aluminum (see Chapters VI and IX) are to be realized fully in terms of mission-effectiveness, economy, etc. An example of the undesirability of this substitution process follows: A B/Al truss system with tubular members could be more effective for certain vehicle configurations than stiffened webs in aluminum sheet; however, the surrounding structures will be quite different for each concept. The B/Al truss requires fittings at discrete points, while the shear and other loads are transmitted uniformly to stiffened sheets by means of

a continuous flange. Although this is the ideal approach during the initial stages of materials introduction, it will be necessary in the design of some components to rely on the substitution method, as for airframe and engine applications, the program manager will require a backup design or "escape route" prior to complete commitment to a new material and process.

Applications of beryllium/aluminum to space vehicle structures have been discussed by Forest and Christian<sup>11</sup> and Korb.<sup>18</sup>

It should be emphasized that remote piloted vehicles (RPV) represent an important opportunity for introducing emerging materials, processes, and radical changes in structural configurations for airframes. The following observations are important for introducing metal-matrix composites in RPVs:

1. The ratio of design ultimate to design limit is reduced from 1.5 for manned aircraft to 1.25 for unmanned
2. The life requirement can be reduced from 6,000 hours for a manned lighter to 100 hours for a low-altitude RPV.
3. Design flexibility with materials systems can be exploited because of reduced stringency of requirements; direct systems design improvement (i.e., aspect ratio and cascading effects of weight savings on configuration)
4. The total cost of the system is considerably less than for manned vehicles
5. The time for development is less; changes can be rapidly incorporated and the impact of technology identified in a shorter time span than for manned vehicles

Should a commitment be made in the United States to lift-jet engines for military V/STOL aircraft, as is clearly the case in several European countries and the Soviet Union, these power plants will provide excellent opportunities for introducing new materials, thus building confidence for later applications to the more critical cruise-jet engines. FOD requirements and, running time for lift-jets are less severe than for cruise-jets.

**TABLE 11 Typical Vehicle Components for Application of Basic Shape**

<b>Basic Shape</b>	<b>Examples of Components</b>
<b>Tape or Strip</b>	Selective reinforcement of metal extrusions, rings, forgings, and pressure vessels; provision of fracture tolerance through crack-arresters
<b>Flat Sheets</b>	Spar and rib webs; fuselage bulkheads
<b>Curved Sheets</b>	Wing panels and canard and stabilizer aerodynamic surfaces (stringer-stiffened and sandwich); landing gear, cargo and access doors; aero-acoustically (and debris) resistant structures, e.g., lower fuselage of STOL aircraft; inlet liners and ramps; mirror substrates.
<b>Stiffening members of constant or moderate taper, e.g., T, Z, and top-hat sections</b>	Stringers for wing skins; fuselage longerons; rib spar caps
<b>Tubes</b>	Floor supports, and spar and rib trusses; geodesic members for cargo aircraft fuselages; fuselage frames and brace members; landing gear elements; spindles and shafts; seat structures; antenna and satellite mounting truss structures; space vehicle cargo manipulator arms; shuttle booster thrust structures; missile warhead supports; launch tubes and missile casings
<b>Cylinders</b>	Missile casing and interstage and tankage; engine inlet ducts.

In each of the vehicles listed, whether military or civil, there are a number of "basic" shapes whose function dictates a recurrent configuration, a common set of functional characteristics, or both (Glasser et al.).<sup>13</sup> These basic shapes, listed in Table 11, can frequently exploit the advantageous properties of metal-matrix composites.

It is possible to visualize the employment of various combinations of the basic shapes in structural design concepts replacing components that are traditionally forged and machined. Examples of such large parts are wing-fuselage frames, fin-body fittings, and landing gear beams. The built-up structures require less machining and avoid the long lead-times currently experienced for forging dies and can consist of plates and standard sections. The elements can be joined by several methods including adhesive bonding, mechanical fasteners, and diffusion bonding. Regarding the latter process, it is important to be aware of two factors: (1) the ease by which titanium fittings (frequently required because of bearing loads and space limitations, e. g., for lugs) can be joined to metal-matrix composites and thermoelastic compatibility, and (2) the hot-isostatic pressing (HIP) facilities becoming available and capable of diffusion bonding structures of 10 feet by 3 feet in size.

In addition, an awareness of the breakdown of material usage for various projects also is useful and is particularly important when considering, for example, the potential market of metal-matrix composites for "upgrading" titanium components or to replace graphite/epoxy skins. In the case of a hypothetical lightweight fighter project, aluminum alloys might account for 75 percent of the weight: titanium, 3 percent; steel, 10 percent; graphite/epoxy, 4 percent; glass-reinforced plastics, 3 percent; and other materials, 5 percent.

The experience being acquired with metal-matrix composites, the cost projections, and the known properties and characteristics of this class of material, suggest that within a decade a number of nonaerospace products could be designed

and produced economically in metal-matrix composites. Such potential opportunities include:

1. Low inertia linkages
2. Impellers of stationary pumps
3. High-speed electromechanical devices in computing systems
4. Transmission shafts
5. Frames and rings for deep-sea submersibles
6. Projectile casings
7. Selective reinforcement of critical pressure vessels
8. Low-weight components of clutches
9. Rotating components of centrifuges
10. Selected automotive usage
11. Naval Launch tubes
12. Gun barrels

## VIII. PRICE PROJECTIONS

As any new material goes through the stages of final development, initial production, and full production, its cost per unit of output will go down because of three effects: experience, technological improvements in the production process, and economies of scale.

The first of these, experience, is exemplified by the typical learning curve, which is simply a reflection of the fact that as people gain experience in carrying out a function they become more efficient and labor costs (in constant dollars) per unit of output decrease. The second effect, technology, recognizes that as time goes by improvements will be made in the production process. Some of these may be large and dramatic, such as developing the knowledge to use a basically less expensive raw material, while others will be small; the aggregate, however, can result in substantial cost reductions. Finally, there are certain scale effects that make high production rates cheaper on a per-unit basis than low production rates. One of these is the fact that high-production-rate machinery and equipment is cheaper on a per-unit basis than low-production-rate equipment (i. e., doubling the capacity of a piece of equipment does not double its cost). Another is the more efficient use of manpower because of specialized tasks. Also there are certain relatively fixed overhead costs that are cheaper on a per-unit basis if they can be spread over more units. In addition, it has to be assumed that a major portion of the plant capacity will be continuously in use.

All three of these effects will operate to reduce the cost\* of metal-matrix composites in the years ahead, assuming these materials win acceptance in the marketplace and production volume builds up as expected. The remainder of this chapter is devoted to a discussion of specific price reductions expected for three promising types of metal-matrix composite (B/Al, B/Ti, and Be/Ti). Prices for filaments and major intermediate forms (tape, plate, and shape) are discussed

\* Where cost projections are given it is assumed that price will follow cost as a result of normal competitive market forces. All costs are expressed in 1973 dollars.

first, followed by a discussion of prices for two components (an airframe structural element and a turbine engine compressor blade). There was no way to project prices of graphite/aluminum because the material is so new; however, such a projection would have been of value had it been possible.

In making the price projections presented here, certain assumptions had to be made regarding total volume of production of fibers and intermediate forms and production volume for the specific components selected to illustrate component price. In all cases a range of volume was selected to illustrate the effect of production volume on price. The Committee did not believe it was possible to predict when, or if, these volumes would be attained, but in the discussions that follow a time period was arbitrarily associated with the various levels of production. The Committee viewed these time periods as reasonable assumptions but not predictions as to when the indicated level of production might be attained. The assumptions also were based on 1973 prices for aluminum and titanium. Correcting for escalating prices in these metals would affect both the composites prices and, more significantly, the comparison with metal parts.

#### A. BORON FIBER

The process of making boron requires the continuous deposition of boron from a gaseous mixture of boron trichloride and hydrogen on a heated substrate (tungsten or graphite). Since this technology is relatively mature, future price reductions are expected to result more from economies of scale as production volume builds up than from experience or technological improvements in the production process. The total filament production volume, assumed but not predicted, will depend on the acceptance of organic-matrix boron fiber composite materials as well as metal-matrix composites.

The estimated price for boron fiber as a function of production volume is shown in Figure 16. The reasons for the dramatic decrease in price as a function of volume are discussed below:

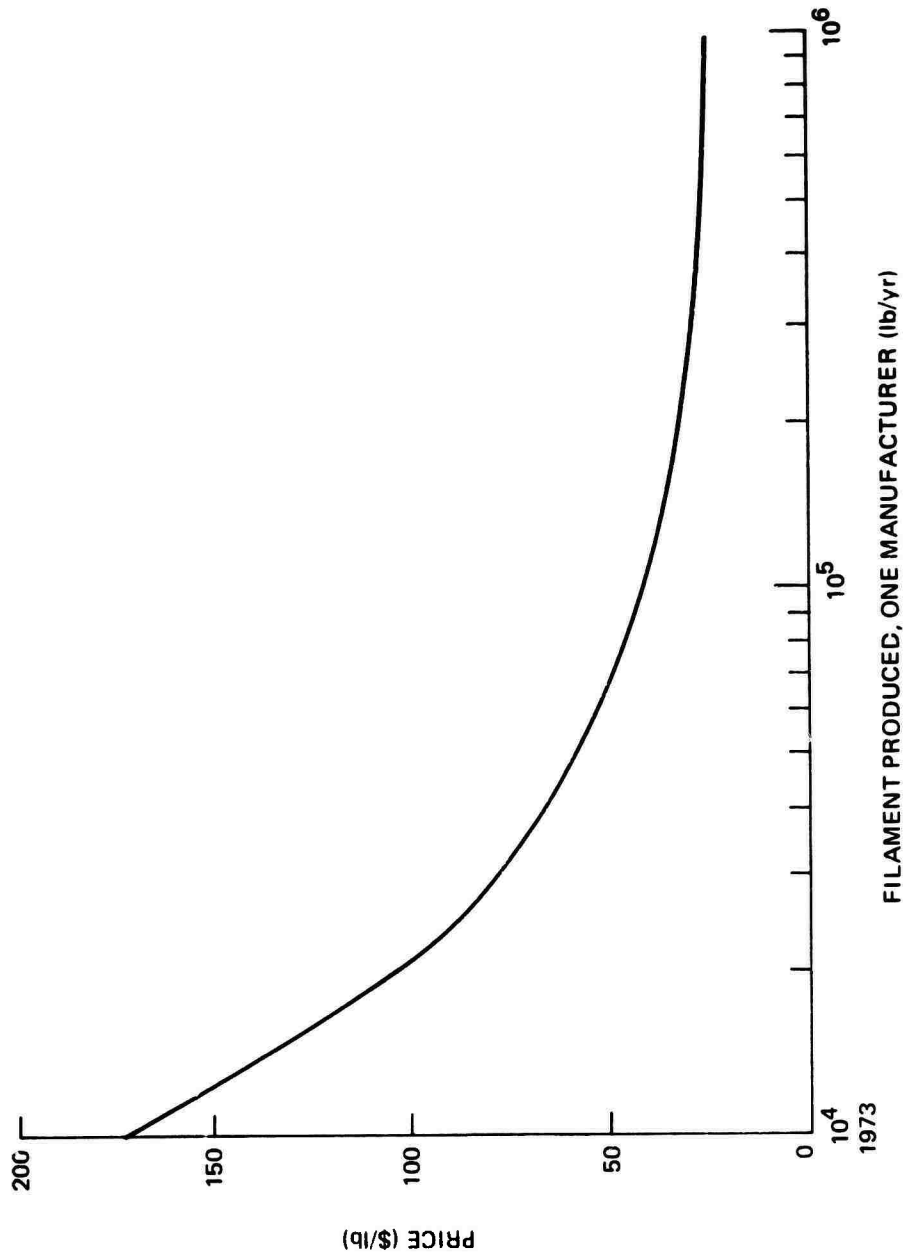

Figure 16 Price/volume projection for boron filament.

### 1. Depreciation

A 10,000-pound-per-year production facility is quite expensive per pound of capacity as compared to a 100,000-or 1,000,000-pound-capacity plant. The depreciation per pound is estimated to drop by a factor of 3 in going from a 10,000-to a 100,000-pound-per-year plant and by a factor of 8 in the 1,000,000-pound plant.

### 2. Materials

It is assumed that the combined costs of the substrate, boron trichloride, and hydrogen per pound of boron filament will drop by a factor of 3 in going to 100,000 pounds per year and by a factor of 5 at 1,000,000 pounds-per-year. This is in part due to the expected decrease in the price of boron trichloride with quantity. Presently the only major market for  $\text{BCl}_3$  is for filament and since over 10 pounds of  $\text{BCl}_3$  are used per pound of boron filament, growth in the filament market will allow major reductions in the price of  $\text{BCl}_3$ . In addition, presently the substrate is 0.5-mil tungsten wire. It is assumed that at large production volumes of boron, alternate and more economical substrates such as carbon or molybdenum will have been developed or alternate processes for manufacturing tungsten wire will result in significant reductions in substrate cost for small-diameter boron. For large-diameter boron substrate cost is relatively less important.

### 3. Burden Labor

An estimate of the cost of labor required to produce the filament is affected by two factors: (a) direct labor, and (b) overhead. The cost of burdened labor per pound of boron is expected to drop by a factor of 3 in going to 100,000 pounds per year and by a factor of 7 in going to 1,000,000 pounds per year. The greater factor of the drop is the burden since many relatively fixed overhead costs are spread over a much larger base.

The estimates of cost per pound of boron on B/SiC filaments assume that a continuing and predictable market exists so that production capacity additions can be scheduled to maintain high plant utilization factors.

## B. B/Al, B<sub>SiC</sub>/Al, and B/Ti TAPE, PLATE, AND SHAPES

Primary fabrication methods are used to incorporate fibers with matrix materials to form tapes, plates, and simple shapes. These intermediate forms of material may then be processed in secondary fabrication steps to form finished parts.

Price projections for B/Al, B<sub>SiC</sub>/Al, and B/Ti tape and plate are shown in Table 12, along with related fiber production volumes and costs. It must be emphasized that the projected price reductions are much more closely related to the associated production volume levels than to chronological time. The projected price levels can be realized only if the associated production volume levels are realized.

The production cost of tape, plate, and shape is made up of four basic elements: (1) raw materials, (2) inspection and preparation of raw materials, (3) consolidation and forming, and (4) quality and process control. The cost of each of these elements can be substantially reduced as production volume builds up. The reduction in cost of fibers with production volume has been discussed. Also, the cost of other raw materials, such as foil, will decrease with volume. The areas of fiber winding and consolidation jointly represent more than two thirds of the total labor cost. Based on practices in the textile industry, with proper equipment and automation the fiber-winding step could be reduced to one third or less of its present level. The consolidation step is another area in which basic automated controls could cut cost to approximately 50 percent of present levels. Throughout the production process, as volume builds up substantial cost reductions can be realized by:

1. Basic automation of the time consuming steps
2. Efficient, continuous usage of equipment and personnel (a good plant utilization factor)
3. Distributing relatively fixed overhead costs over a larger production quantity

TABLE 12 Fiber, Tape, and Plate Price Projections (1973 dollars)

Total Boron Fiber Market (lbs/yr and yr)	Each Supplier <sup>a</sup> (lbs B fiber/yr)	Price of 5.3 mil. Boron Fiber <sup>b</sup> (\$/lb)	Green Tape (Al + coating)	Plasma Sprayed Tape	Plasma Sprayed BSiC Tape	Boron-Al Plate	B/Ti <sup>c</sup> Tape
20,000 - 1975	10,000	150	\$110 (2,000 lb)	135 (2,000)	160 (2,000)	140 (2,000)	135 (2,000)
200,000 - 1980	100,000	50	40 (2,000)	51 (20,000)	56 (20,000)	60 (20,000)	60 (20,000)
2,000,000 - Post 1980	1,000,000	25	21 (200,000)	30 (200,000)	33 (200,000)	35 (200,000)	35 (200,000)

Note: Price in \$/lb, figures in ( ) are assumed quantities in lb/yr

<sup>a</sup>There are two U. S. suppliers of this material

<sup>b</sup>Price of B/SiC filaments will be 10 to 25 percent higher than that shown for boron filament.

<sup>c</sup>Single source projections.

The specific assumptions (based on 1973 prices for tungsten filament) used in arriving at the price projections shown in Table 12 are as follows:

1. Assumptions for 1975\*

- a. 2,000 lb of composite/yr
- b. \$150/lb filament cost, \$19.30/lb Ti (3-2.5), \$1.50/lb 6061 Al

2. Assumptions for 1980\*

- a. 20,000 lb of composite/yr
- b. \$50/lb filament cost, \$15/lb Ti (3-2.5), \$1.50/lb 6061 Al

3. Assumptions for Post 1980\*

- a. 20,000 lb of composite/yr
- b. \$25/lb filament cost, \$15/lb Ti (3 -2.5), \$1.50/lb 6061 Al

C. BERYLLIUM/TITANIUM PLATE AND SHAPE

The Be/Ti composite system is more closely related to conventional metals in technology than are alternate composite systems, a major factor in its lower cost. Basically the material is made by co-extruding commercially available Be and Ti into a consolidated composite shape. The technology, materials, and capital equipment currently are available and no additional major capital equipment scale-up is required.

Price projections for a Be/Ti plate (50-v/o Plate - 36 in. x 96 in. x 0.100 in. thick) and shape (50 v/o Hat Section - 0.100 in. thick) at three production volume levels is shown in Tables 13 and 14.

D. AIRFRAME AND STRUCTURAL ELEMENT

To gain some understanding of the cost-in-use of metal-matrix composites in airframe structures, the costs of a simple skin-stringer panel (Figure 17) were calculated for production levels of 1, 100, and 1,000 units for various types of metal-matrix composites. For simplicity, each panel was sized to carry the same

\* Price changes of metals, including Al and Ti, during 1974 might lead one to predict increased metal costs, even with greater volume.

TABLE 13 Price for Be/Ti Plate (1973 dollars) - (Total cost in thousands of dollars)

Item	@ 2,000 lbs/yr	@ 20,000 lbs/yr	@ 200,000 lbs/yr
Raw Materials	37.0	319	2,850
Tooling	14.0	91	910
Press Time	12.0	14	120
Labor @ \$20/hr	6.4	56	490
Mill Time	1.2	9	83
Sub-total	70.6	489	4,453
G & A	14.1	98	891
TOTAL	84.7	587	5,344
\$/lb	\$42.36	\$29.35	\$26.72

- a. Be/Ti tubes of 12-in. outside diameter, 0.200-in. wall are produced by extrusion of Be and Ti powder mixtures
- b. These tubes are cut to required lengths (52 in.) and split longitudinally
- c. The split tubes are "unwrapped" into a nominally flat configuration using three-roll apparatus
- d. The unwrapped tube stock then is rolled in the longitudinal direction to required gage

TABLE 14 Price for Be/Ti Hat Section (1973 dollars) - (Total cost in thousands of dollars)

Item	@ 2,000 lbs/yr	@ 20,000 lbs/yr	@ 200,000 lbs/yr
Raw Materials	35.1	311.2	2,775
Press Time	3.1	23.5	193
Tooling	1.9	13.0	110
Labor @ \$20/hr	8.8	84.0	840
Sub-total	48.9	431.7	3,918
G&A	9.8	86.3	784
TOTAL	58.7	518.0	4,702
\$/lb	\$29.34	\$25.90	\$23.51

- a. The part is produced by direct extrusion of Be/Ti powder mixtures to  $\pm 0.035$ -in. tolerances
- b. The extruded bars are drawn to  $\pm 0.005$ -in. tolerances
- c. Bars are cut to length for shipment

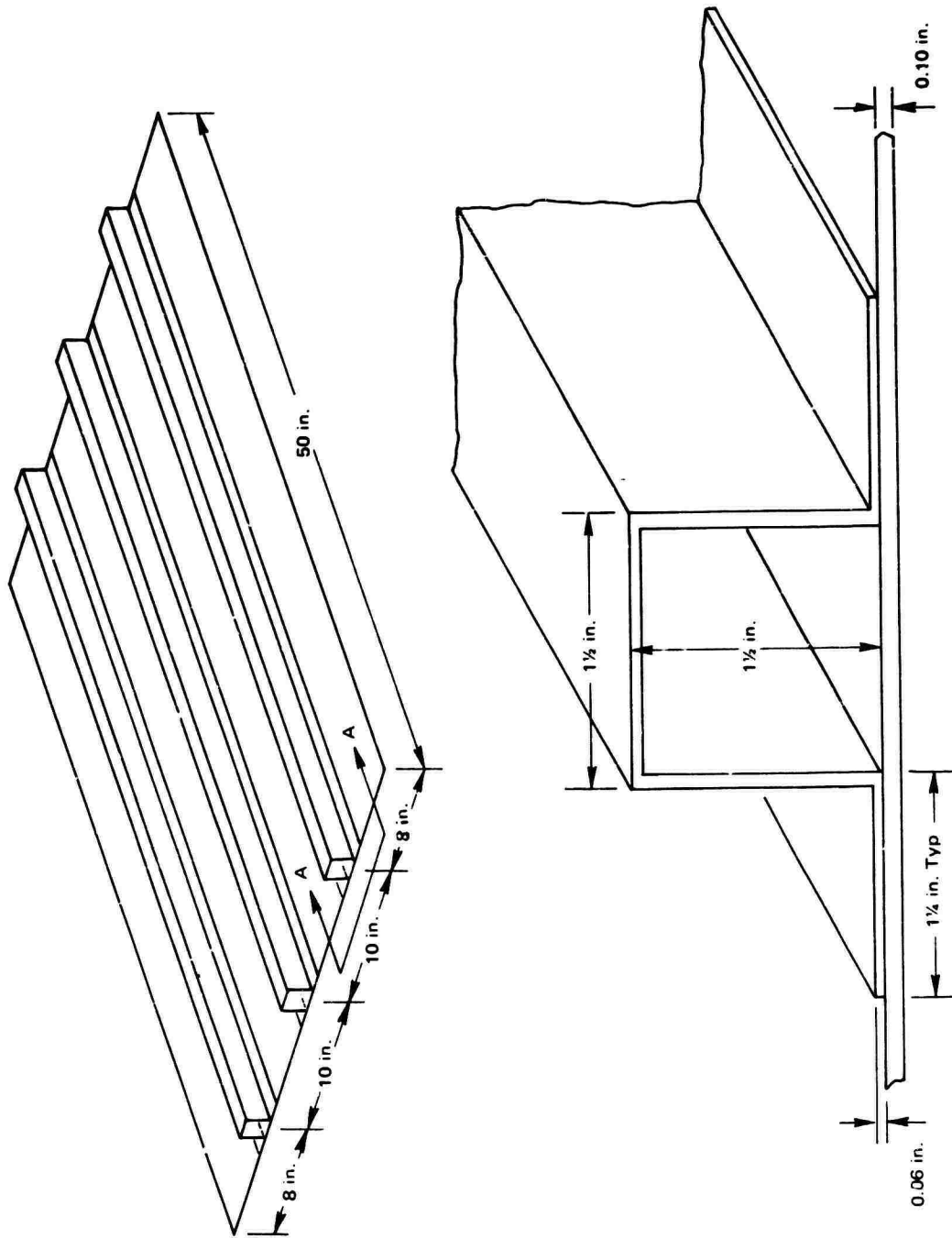

Section A-A

FIGURE 17 Skin-stringer panel chosen as airframer element in estimating costs.

axial compression load but without consideration of buckling. In practice, structural elements commonly carry some transverse load. Since the transverse strength of composite laminates is relatively low, cross-plying of panel skins may be employed, degrading somewhat the apparent outstanding strength/weight advantage of metal-matrix composites. For one unit, the least expensive and lightest weight configuration is the diffusion-bonded B/Al plate with three B/Al stringers, mechanically fastened. For 100 or 1,000 units, the least expensive configuration is the B/Al plate with three Be/Ti stringers, mechanically fastened.

Cost projections for the metal-matrix panel made by another estimating team and showing a percentage breakdown of costs by manufacturing, quality control, tooling, and material are shown in Figure 18. This estimate of cost is somewhat different from that shown in Table 15 (configuration 5), reflecting some difference between the two groups in the final weight of the piece and in production techniques. However, except for the initial estimate of one unit in 1975, the estimates made by both groups are in substantial agreement.

For all configurations considerable cost reductions are realized as the production level is increased. The most significant reduction in costs as a function of number of units produced is in the tooling. Tooling costs amount to 17 to 23 percent of total costs when producing only one unit of hardware but are reduced to 0.5 to 1 percent when producing 100 to 1,000 units.

Significant cost reductions also occur in the quality control, inspection, and manufacturing of composite hardware with increased production. These cost reductions occur primarily due to increased automation and decreased costs as a result of learning curve.

The most important reduction in cost as a function of time is the very significant reduction in composite material costs. There also are some decreases in quality control and manufacturing cost projections which result from improvements in the technology of composite fabrication.

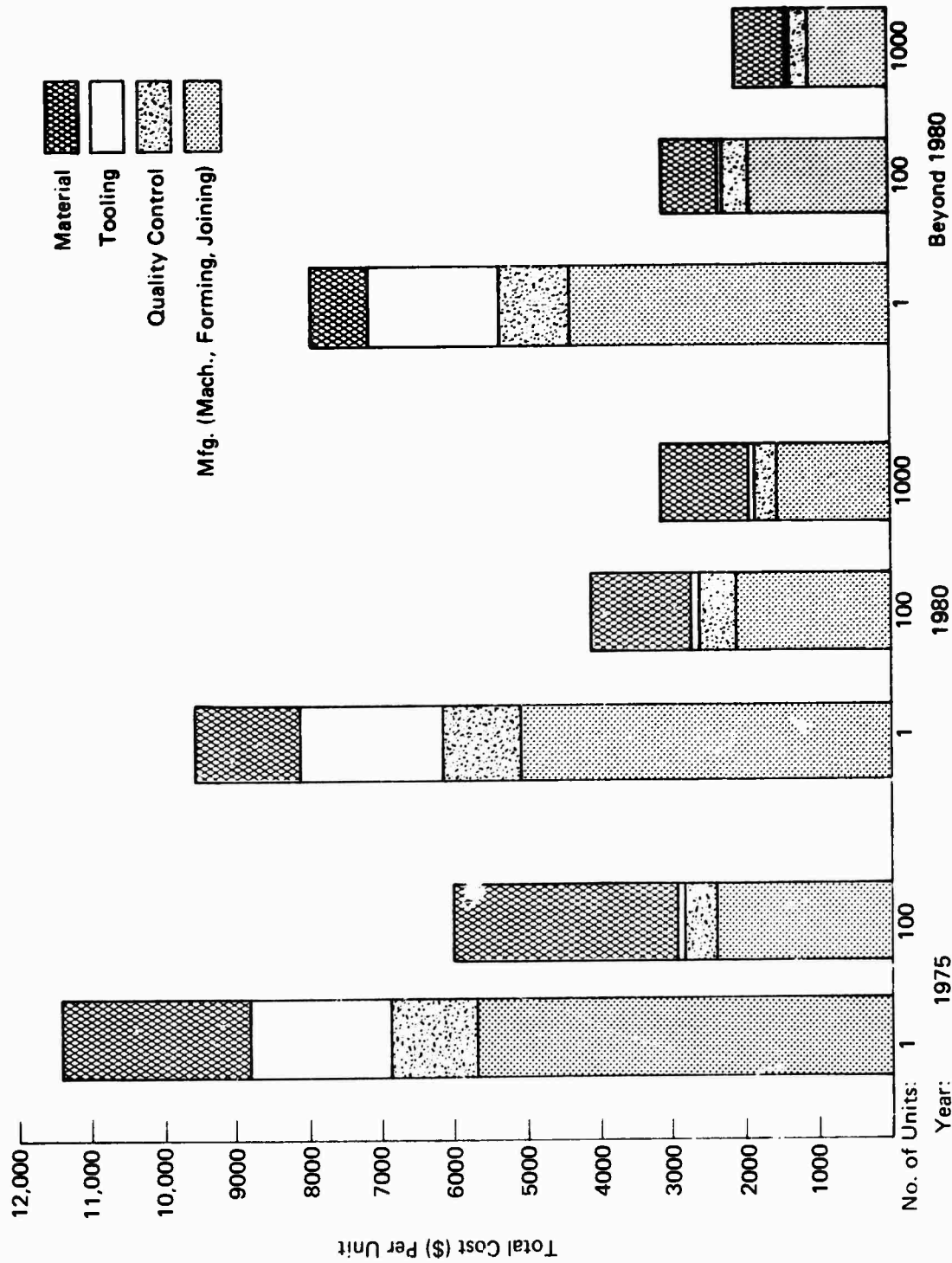

FIGURE 18 Cost estimates (1973 dollars) for producing airframe hardware out of D/Al (material cost assumed to be constant).

TABLE 15 Panel Weight and Cost Comparison - All Panels are 36 x 50-in. reinforced with 3- 1/4 x 1/4 in stringers

Panel Description	Total Weight Per Unit (lb)	Material (1) Cost/Unit	Labor (2) Cost/Unit (3)	Tooling (4) Cost/Unit	Total (5) Cost/Unit
Diffusion bonded B/Al skin and hot formed B/Al hats - mechanically fastened	25.0	\$4,056	\$1,257	\$ 22	\$6,402
7075-T7351 Al plate skin and 7075-T6 Al extruded hats - mechanically fastened	107.8	\$ 188	\$ 656	\$ 15	\$1,031
G/E skin and hats adhesively bonded	33.0	\$ 870	\$2,835	\$ 177	\$4,659
B/E skin and hats - adhesively bonded	19.0	\$2,440	\$2,402	\$ 177	\$6,023

- Buckling not considered in design of test panel
- Materials and costs: B/Al processed plate - \$140/lb, G/E 3-inch tape - \$20/lb, B/E 3-inch tape - \$95/lb
- Labor cost based on \$20 per manhour
- B/E and B/E labor includes improvements through use of automated tape layup and laser cutting of skin (Hand layup and cutting used for fabrication of hats)
- Tooling cost amortized over 100 units
- Total cost includes 20% G & A expense on top of material, labor and tooling cost
- Panel dimensions shown in Figure 17. Material Thicknesses:

	Skin	Hats
B/Al	0.100	0.060
Al	0.435	0.282
G/E	0.202	0.130
B/E	0.105	0.068

In Table 15 the projected 1975 cost of the B/Al panel at the 100-unit level of production is compared with projected costs of producing similar compression panels (each designed to withstand the same uniaxial load) in aluminum, graphite/epoxy, beryllium/titanium, and boron/epoxy. The conventional aluminum panel is substantially cheaper than any of the composite material panels (\$1,031 compared to over \$6,000) but is also three to five times as heavy. The E/Al panel has the advantage over the graphite/epoxy panel since it is lighter and a little cheaper. However, the metal-matrix panels are heavier and more expensive than the boron/epoxy organic-matrix composite panels. For convenience in calculation, unidirectional composites were assumed. Such design is unlikely in practice, and the degree to which divergence from uniaxiality occurs affects the comparison with a homogeneous material and, to a lesser degree, the comparison of one composite with another.

Due to the simplicity of the panel configurations used for the cost comparison, these cost data should not be considered generally applicable. The panel is a simplification of the kind of structure that would be used in airframes; however, in real structures various complexities would tend to change the relation between the costs of the various types of panel configurations. Such complexities would be changes in cross-section thickness, curvature, twist, access holes, built-up areas around fastener holes, and possibly a honeycomb core skin in place of the monolithic skin. Therefore, the cost data presented are minimum values that would normally be multiplied by a complexity factor (complexity factors encountered in aircraft configurations have ranged from 1 to 10). Considering the technical advantages these materials have to offer, the goal of actually achieving these projected costs would seem to be well worth pursuing.

#### E. TURBINE ENGINE BLADE

The second component costed in an effort to understand in-use costs of metal-matrix composite materials was a turbine engine blade. The configuration chosen is representative of first-stage fan blades for a supersonic engine suitable

TABLE 16 Projected Cost of Metal-Matrix Fan Blades (1973 dollars)

Blade	1975		1980		1980-85	
	1,000/yr	1,000/yr	1,000/yr	1,000/yr	1,000/yr	10,000/yr
Boron (SiC) Aluminum	695 <sup>a</sup>	569 <sup>a</sup>	163 <sup>a</sup>	550 <sup>a</sup>	152 <sup>a</sup>	
Boron Titanium	623 <sup>b</sup>	547 <sup>b</sup>	121 <sup>b</sup>	534 <sup>b</sup>	108 <sup>b</sup>	
Beryllium Titanium <sup>c</sup>	438 <sup>b</sup>	438 <sup>b</sup>	141 <sup>b</sup>	438 <sup>b</sup>	141 <sup>b</sup>	
Titanium (base) 6Al-4V alloy	445	445	160	445	160	

<sup>a</sup> Average of four separate estimates

<sup>b</sup> Single source estimates. In the case of B/Ti, the projected cost estimates from a single source indicate that the cost of a B/Ti blade will be lower than that of a B/Al blade because of the elimination of splayed root, leading edge protection, and cross-plying and the shorter hot pressure bonding dwell time. The lower indicated cost of B/Ti compared to B/Al has been attributed to inexpensive forming on conventional metalworking equipment.

<sup>c</sup> Time frame not important for Be/Ti blades

Assumptions for Blade Costing

1. S25/hr was used for labor plus overhead.
2. Material and labor cost elements were marked up by 20% (general & administrative).
3. The blade fabrication process is based on the use of diffusion bonded monotape through a one-step hot pressure bonding approach for the blade molding (B/Ti), or green or plasma - sprayed tape (3/Al).
4. Blade Data:
  - length = 10 in.; chord width = 2.5 in.; thickness = 1/3-in. to 1/4-in.
  - average airfoil pitch thickness = 0.187
  - average airfoil volume = 0.187 x 2.5 x 10 = 4.7 in.<sup>3</sup>
  - B/Al airfoil wt. = 4.7 x 0.1 = 0.47 lb.
  - B/Ti airfoil wt. = 4.7 x 0.13 = 0.61 lb.
  - Ti airfoil wt. = 4.7 x 0.16 = 0.75 lb.
5. Assume that actual reduction in airfoil volume due to chord taper is equivalent to material waste.
6. For the B/Al blade, wedges are made from stainless or titanium alloy.
7. For the B/Al blade, stretch formed and plated stainless leading edge inserts are used.
8. For B/Ti blade sprayed root (hence wedges) and leading edge erosion/FOD protection were assumed to be unnecessary.
9. At the 10,000 blade level it is assumed that the plant is producing a total of 50,000 similar parts.
10. Constant (performance or weight).
11. All costs are in 1973 dollars

for fighter aircraft. The basic assumptions for the costing exercise are listed in Table 16.

The projected costs for three types of metal-matrix composite blade are shown in Table 16 and compared to a conventional (titanium) blade for two levels of production at three time periods. The significance of this tabulation is that by the 1980 period at a production level of 10,000 blades per year, both the B/Ti and Be/Ti blades are less expensive than the titanium blade. By the 1980-85 period, all the metal-matrix composite blades are expected to be cheaper than the titanium blade. The projected low price of the B/Ti blade is attributed by potential producers of B/Ti blades to the elimination of root wedges, leading edge protection, and cross-plying. Potential producers of B/Al blades, not surprisingly, believe that B/Al blade prices will be lower.

Since the Committee initiated this cost-estimating exercise, considerable change has occurred within the industry due to the application of improved designs and, more important, improved production manufacturing techniques. As is mentioned in the conclusions, the recent accomplishments of one manufacturer in the redesign and manufacture of a boron/aluminum Stator resulted in a lower cost (-67%) over a 12-month period through the use of automated and reduced-time fabrication techniques. This type of dramatic change vividly demonstrates the futility of projecting costs 10 years ahead during the evolutionary period of a new material system. The Committee agrees that based upon the recent cost reduction emphasis as typified in this stator application, the cost of metal-matrix composite parts can be lower than the solid metal parts they are replacing.

The achievement of these cost projections depends primarily upon a shift from the expensive, hand-tailored, laboratory-produced composite blades of today to an automated, assembly-line operation. The following list shows the types of equipment and tools that are necessary to achieve production-quality, economically competitive fiber-reinforced metal-matrix composite material blades. Studies have been conducted by all of the current blade and vane vendors in this area and

facilities have been planned based on logical extensions of current techniques. However, it should be noted that significant investments in time and money will be required to reduce these techniques to efficient production practice. Specifically, the following improvements in fabrication practices are needed for the fiber-reinforced blades:

1. Blade Subelements--Numerical controlled machines; gatorizing or form rolling to produce spars, leading edge sheaths, root blocks etc. , in volume; powder metallurgy also is a strong candidate in these areas
2. Assembly--Mechanized machine or laser ply cutting, automated numerically controlled layup; computerized ply layup design
3. Consolidation--Eliminate vacuum requirements, shorter bonding cycle, continuous hump furnace, isostatic pressure bonding, shuttle box, multiple bonding for volume, and use of monotapes
4. Machining--Automatic broaching of roots; reduced root machining through design improvements
5. Finishing--Improved tip cutting and blending; multiple plating tools; volume
6. Inspection--Automated C-Scan or holography techniques

A key element in production practice will be quality control to permit the attainment of reproducible sound structure from part to part. Automated (to reduce costs to an acceptable level) C-Scan and holographic techniques have been proposed for this purpose, and it is believed that these techniques will require the greatest development efforts.

## IX. THE CASE FOR METAL-MATRIX COMPOSITES

To exploit any new technology it is necessary, by means of systems analysis, to determine its potential impact on systems concepts, vehicle design, life-cycle costs, and mission effectiveness. As is the case with all emerging materials and processing technologies, the properties and characteristics of metal-matrix composites must be made known to the preliminary design groups where trade-offs are being made continuously between mission requirements, customer specifications, and configuration (Phase I and II below). It is during these phases of the design process that considerable freedom exists in the selection of appropriate technologies.

The structural design process can be viewed in a simplified way as follows, with iterations, of course, between the various phases:

Phase I	Customer specifications
Phase II	Preliminary design Preliminary sized and weighted configuration
Phase III	Detail design
Phase IV	Development
Phase V	Qualification tests
Phase VI	Operation

The preliminary designer provides data at an early stage for the formulation of required operational capabilities, develops configurations, conducts parametric trades, assembles advanced technical data and performs cost-effectiveness studies. Unless emerging materials are introduced at the preliminary design stage, they will be used mainly on a substitution basis for components already committed to production employing conventional materials, fabrication processes, and design concepts. Radical changes in design will not be possible and an evolutionary process based on substitution does not always permit all advantageous characteristics of a new material or process to be exploited fully.

Two examples of the systems impact on aircraft design of specific properties of B/Al composites that can only be achieved at the preliminary design level are described below:

- Property--High compressive strength of unidirectional boron/aluminum of over 400 ksi, compared to approximately 130 ksi for graphite/epoxy, approximately 300 ksi for boron/epoxy and 130 ksi for titanium 6Al-4V. Compressive strength properties in the range of 700 to 800 ksi have been reported with boron/titanium.

Influence--Wing configuration of high-altitude remote-piloted vehicle: An endurance of 24 hours and the high-altitude of 60,000 to 80,000 feet required for operation, results in the need for an ultra-high aspect-ratio ( $\text{Span}^2/\text{Area}$ ) of 35 being sought at the preliminary design level for the wing. An increase in aspect-ratio improves the lift/drag ratio and range; however, wing structure weight limitations, the need to maximize fuel volume, and the high wing span result in compressive stresses of approximately 300 ksi in the upper spar cap. The high compressive strength property of B/Al therefore can be utilized because the required wing configuration can be realized and would enable accomplishment of the mission. However, this composite also is suggested because the simple, B/Al spar cap with unidirectional fiber orientation would enable integration, through brazing or adhesive bonding, with a titanium channel welded to an efficient sine-wave spar web. This may result in spar fabrication costs not much higher than those a conventional spar in titanium and lower than those a typical riveted aluminum spar, but meeting the mission requirements. Such systems studies should be conducted on metal-matrix composites to reveal the ultimate potential of these materials.

- **Property--Fatigue properties, the high endurance limit (60 to 80 percent of static strength) and extensions of fatigue lives possible with B/Al (Bunk,<sup>4</sup> and McQuillan,<sup>21</sup>). A box beam designed and fabricated by Convair Aerospace, San Diego, enabled five design life-times (i. e. , 31,000 equivalent flight hours) to be achieved. Excellent fatigue properties also are a feature of B/Ti, which further provides a simpler solution at lug connections that are frequently specified in titanium due to space limitations.**

**Influence--Since early 1950, the trend in civil and military aircraft design has seen the development of fail-safe wing structures and the spars therefore have increased in number from two to, in some cases, six or more (Lundberg,<sup>19</sup>). The exploitation, at the preliminary state of the excellent fatigue properties of metal-matrix composites would enable a reduction of the number of spars. This property therefore would enable safety levels to be maintained or improved with a simpler structure and also would offer the potential, due to the lower part count and associated assembly costs, to significantly reduce the acquisition and ownership costs of the system. The constraints existing when a metal-matrix spar material is substituted for a conventional material after the detail design phase has been accomplished would not enable all of the above benefits to be realized.**

The advantages of metal-matrix composites have been listed earlier in this report. The impact on systems design of some of these properties and characteristics are suggested below:

- **Property--Interlaminar and transverse strengths of aluminum, beryllium, and titanium matrices are significantly higher than**

resin matrices; these properties also can be varied, as metal matrices are heat-treatable.

Influence--The need to cross-ply the metal-matrix composites becomes small. While this may not be a significant factor for fan-blade production, due to complex loading conditions, the ability to fabricate, for example, panels of lifting-surfaces with mainly zero degree ply does simplify this process and has the potential to reduce cost. Higher specific compressive strength properties also result, as any crossplying required with composite detracts from longitudinal strength. Due to matrix properties, the off-axis strength of B/Ti is, of course, considerably higher than for B/Al.

- Property--Matrix is hard and does not need environmental protection.

Influence--Damage in service less likely, which reduces maintenance costs. Lightning protection not required (approximately 6 lb on the F-14 boron/epoxy horizontal stabilizers). Attractive for leading edges of lifting surfaces of STOL aircraft thereby alleviating damage problem, for example, due to debris from unprepared fields. There is no influence of humidity.

- Property--Thermal-expansion coefficient.

Influence--Provides considerable freedom in design due to thermoelastic compatibility with steel and titanium frequently required for attachment lugs due to space limitations. Forged titanium structures also can be selectively reinforced with B/Al or B/Ti at probable points of failure. Strategic materials and

power requirements for machining can be conserved. Fail-safe interleaves of titanium or stainless steel mesh can be introduced in B/Al components with a small increase in fabrication costs. Interleaves improve bearing and transverse strengths of B/Al. With B/Ti, such reinforcement is not necessary.

- Property--Elevated temperature performance of B/Ti and Be/Ti.

Influence--The elevated temperature properties of titanium and beryllium far exceed those for high-temperature organic matrices such as polyimides requiring complex curing procedures. In the case of titanium/6Al-4V, imbedded boron fibers have significantly improved the creep and rupture properties of this material. These metal-matrix composites therefore can be used for high supersonic vehicles and for engines with high inlet temperatures.

- Property--Thermal conductivity not offered by resin-matrices.

Influence--Of importance for convectively cooled load-carrying structures (structural heat exchangers) of advanced aerospace vehicles.

- Property--Proven joining methods are applicable, i. e. , adhesive bonding, brazing, welding and mechanical fasteners. Diffusion bonding also shows considerable promise. Emerging joining systems such as weld bonding and rivet bonding also are applicable for some structural components.

**Influence--Freedom with joint design at both preliminary and detail design stages. This is very important as joints can be costly in design, fabrication and in operation. B/Al is acceptable in many fabricating shops due to frequent familiarity with a joining method that can be employed. Aerospace industries are also familiar with titanium.**

- **Property--Available in sheet and basic structural shapes; selectively reinforced titanium extrusions also within the state of the art.**

**Influence--Familiar concepts for various disciplines in the development-design-fabrication process, to metalworking shops and the customer. Because unidirectional fibers can be frequently used, the methods of analysis are not complex, which further accelerates the application's process, builds confidence and reduces testing.**

Thus, it is evident that preliminary design groups must be aware of properties of emerging materials if maximum payoff is to be achieved and if materials research and materials engineering efforts are to be aligned with systems requirements.

The emphasis on the reduction of acquisition costs provides challenging opportunities to design radically different structures that will utilize the excellent fatigue properties, compressive strengths, etc., of metal-matrix composites. It should be possible not only to reduce first cost but also to reduce ownership costs. However, prediction of life-cycle costs is difficult and only limited information is available on military aircraft, (in the commercial world, the equipment is designed to sell at a price that a market analysis shows the customer is willing to pay). The importance of life-cycle costs is revealed by the following data on the B-52:

Preliminary Design	\$ 0.1 billion
RDT&E	\$ 0.5 billion
Acquisition	\$ 5.7 billion
Operation	\$20.7 billion

The above breakdown is not, of course, universally true but it does indicate the importance of design to minimize maintenance.

The case for the metal-matrix composites in view of comments made above, is that they:

1. Offer reduced weight and improved vehicle sizing capabilities
2. Offer higher aspect ratios that increase range or reduce fuel consumption
3. Have the ability to alleviate aeroelastic problems
4. Might permit a lower part-count for sub-assemblies
5. Can be joined using conventionally accepted methods (i.e., fasteners, brazing, and welding)
6. Offer higher bearing strength with B/Al, titanium skins can be introduced to improve bearing strength, but this is not necessary with B/Ti or Be/Ti
7. Offer strengths that reduce the need for fiber crossplying and simplify fabrication for airframes
8. Offer post-buckling strength that enables efficient structures to be designed
9. Provide opportunities for discontinuous tubular (geodesic and multilayered fracture-tolerant structures
10. Offer increased fatigue life and endurance limits
11. Require no environmental protection (i.e., for humidity, lightning, and impact due to tools, etc.)
12. Offer greater thermal conductivity that reduces thermal stresses and hot spots and enables development of convectively cooled structures
13. Permit a wider choice of subcontractors for the assembly of some components because of the applicability of metal-working methods.

Reduction to practice of any new material in aircraft gas turbine engines always has required specific advantages in performance, weight, or durability over existing materials, and the confidence through testing to assure the very high reliability required. In addition to this criteria, cost has become a requirement of ever increasing importance. In order to achieve acceptance and application in engines, composites must satisfy these factors.

Composites have been of strong interest in aircraft engine applications because of their high strength-to-density ratio that provides a significant potential for weight reduction and performance improvements. There are two areas of prime interest at this time for composite applications in engines: The first is a replacement for titanium in the fan section of modern engines; the second is in the high-temperature region, specifically the compressor and fan drive turbines. Titanium is used because it has a higher strength-to-density ratio than steels or nickel-base alloy substitutes, provides the lowest possible weight, and allows the high-tip-speed fans required for low specific fuel consumption, that increases range. Composites must challenge, and prove themselves superior to, titanium alloys to gain acceptance.

A recent problem with titanium alloys, particularly in the latest engines that extensively use these alloys, is that of titanium fires. It has been demonstrated that if titanium parts are rubbed together, particularly in the case of a high-speed rotor part contacting a static part, a self-sustaining destructive fire can be generated. In some applications steel alloys have been substituted for titanium because of this problem. Obviously, significant substitution of heavier steel alloys would negate the high-strength-to-weight-ratio engines that are needed for modern aircraft. There has been at least one situation reported where B/Al fan blades were vigorously rubbed into a titanium case without a resultant fire. The possibility of substitution of composites for titanium to prevent titanium rubbing and possible resultant fires and maintain or improve strength-to-weight is therefore a strong one, and this area should be investigated thoroughly.

In low-to medium-temperature applications, fan blades and vanes have been a primary objective for composites because of the near-term payoffs. For transport, bomber, or other subsonic applications, metal-matrix composites must compete with epoxy-matrix composites that can operate in the subsonic temperature environment. For the higher-temperature supersonic applications polyimide-matrix composites are the only current competitive candidates for metal-matrices. A prime factor in choice for this application is the ability of the material to withstand foreign object damage and erosion as well as the currently used titanium blades and vanes. An additional consideration is the ability of the blades to withstand the severe vibration environment induced by aerodynamic and mechanical forces. Though the polyimide-matrix blade may offer lower weight, there have been more developments recently in metal-matrix blades for supersonic engines such as the F-100, J-79, and TF-30. Conversely, a greater effort has been placed on epoxy-matrix blades for transport-type aircraft engines such as the TF-39 and JT-9D.

This is indicative of the state of the art of composites to withstand FOD and to meet the vibration environment. Although resin-matrix composites can offer greater potential weight reduction, their ability to meet design conditions in the supersonic applications has not been demonstrated. It is believed, therefore, that metal-matrix composites should be further developed particularly in the area of FOD resistance. Further, it should be noted that within the metal-matrix candidates of  $B_{SiC}/Al$ ,  $Be/Ti$ , and  $B/Ti$ , potential FOD resistance is superior to that of resin-matrix composites.

The weight payoff for composite blading depends upon the degree of application, which could vary from a direct substitution to a totally new system design reflecting full composite potential. This degree of application of course is a function of the level of confidence achieved.

For the direct substitution path a 30 to 40 percent reduction in fan blades and vanes over titanium has been demonstrated. Further reductions in disk and

rotor supports are possible by this path with a projected payoff of an additional 10 to 20 percent of the titanium blade weight. In an F-100 engine this would mean a total potential of 35 to 40 pounds weight reduction in its three-stage fan. As noted in the cost section of this report, metal-matrix composite blades are projected to be cost competitive with titanium blades on a projected production basis. Direct substitution also allows testing in existing engines.

The next step in blade application would be an optimization of blade and disk design to optimize the geometry, particularly the chord of the composite blade. For this approach several designs have been accomplished which show that through use of a wider chord metal-matrix composite blade, the number of blades required could be reduced over a titanium application with a resultant improvement in performance and capability (surge margin) through the wider chord. A typical study by United Aircraft Corporation shows that through a reduction from 34 titanium blades to 22 B<sub>SiC</sub>/Al blades, a 20 percent decrease in cost due to the reduced number of blades required and a 40 percent reduction in weight can be achieved.

The third step involves a total systems approach to fully utilize the high-strength/density of metal-matrix composites. In this case the approach would be toward a higher tip speed fan with accompanying higher stage pressure ratio that would produce more work in the fan, at greater efficiency, reducing the work required in the compressor and the fan drive turbine, for a given system requirement. This would allow a reduction in compressor stages and/or heavy, expensive turbine stages. One such study, conducted on supersonic fighter advanced for technology by the USAF Aeropropulsion Laboratory, indicated the following potential savings:

Two-Stage Advanced Fan

High Tip Speed  
One Stage Drive Turbine  
Eliminates Forward Bearing  
B<sub>SiC</sub>/Titanium Blades

Conventional Three-Stage Fan

Moderate Tip Speed  
Two Stage Drive Turbine  
Requires Forward Bearing  
Titanium Blades

446	Weight (lbs)	535
174	No. of parts	244
72	Cost factor (%)	100

The advantages do not include the cost and weight gains by elimination of a turbine stage.

Additional areas of potential low- to medium-temperature engine application include static structures such as cases and frames, and external bosses, cases, plumbing, and brackets. The estimated total potential weight savings in these areas for a metal-matrix composite application is 15 percent of a typical supersonic fighter engine. While considerable effort has been expended on blades and vanes, these applications also should be given more attention.

High-bypass-ratio turbofan engines are considered very attractive for STOL aircraft, which are efficient aircraft that can use small airports close to population centers. Further, they offer the potential to significantly reduce noise levels around airports. However, unless composite materials are substituted for the conventional titanium these high-bypass-ratio turbofan engines would suffer a severe weight penalty because of the very large fan blades. Composite fan blades with high specific modulus also offer the potential of variable pitch because they do not require midspan shrouds. Variable pitch capability means that fan blades can be used for thrust reversal braking during landing. Thus, composite blades save additional weight by eliminating the need for separate thrust reversal systems. They also provide added landing flexibility reducing the ground area subjected to aircraft noise. Taken overall, the penalties that accrue with conventional titanium fan blades indicate that the economic and environmental viability of high-bypass-ratio turbofan STOL vehicles is dependent upon the use of composite materials for fan blades.

The primary interest areas for high-temperature engine composite applications are turbine blades and vanes. In current engines, superalloy castings combined with optimum cooling schemes are used to reach the maximum allowable

turbine temperatures. Further increases require new or improved material systems or advances in cooling technology. A number of composite systems now in the process of development involve fiber-reinforced superalloys or ceramics and eutectics and have the potential for turbine temperature increases of 100 to 300 °F or for reductions in required cooling air. These systems should continue to be supported because of their near-term payoff potential.

## X. IMPEDIMENTS TO USAGE OF METAL-MATRIX COMPOSITES

The observations made in February 1972 by the AF/NASA long-range planning study, Composites Recast, still hold true; that is, there are two major impediments to the wide usage of metal-matrix composites--confidence and cost.

### A. LACK OF CONFIDENCE

Lack of confidence in metal-matrix composites exists because:

1. The data base on the behavior of metal-matrix composites under actual service conditions, such as those encountered by aircraft engine fan, compressor, and turbine blades, and aircraft and missile structural elements, is inadequate. These conditions involve shock, vibration, foreign object damage, dust and rain erosion, resistance to lightning, oxidation, corrosion, and thermal cycling; without a thoroughly documented data base covering all of these conditions together with well defined safety factors, designers will be reluctant to incorporate metal-matrix composites into critical aircraft structures and components.
2. Experience demonstrating the reproducibility of material properties is limited and makes the reliance that can be placed on indicated design properties uncertain.
3. Acceptable accelerated test methods are lacking. Since there are no currently acceptable accelerated methods for reliably simulating service conditions, this data base must now be built slowly, extensively, and reliably through the careful testing and evaluation of these components under actual conditions.
4. Uniform or standardized composite test procedures that provide a common base line for comparing composite performance are lacking. Without such standardized tests, results obtained by different organizations on composites cannot be reliably compared and assessed.
5. Designer awareness of the special advantages of metal-matrix composites is limited-- Designers who are well versed in the use of monolithic metals are reluctant to risk their reputations on metal-matrix composites unless they are thoroughly familiar with their special advantages, limitations, and characteristics.

6. Analytical methods and data for determining cost effectiveness and life-cycle costs are limited. The use of such methods is essential to justify these materials.
7. Inspection and nondestructive testing techniques for determining internal flaws such as poor fiber-matrix bonding, broken fibers, fiber-matrix reaction, and fiber-fiber contact are limited.
8. Established repair and overhaul methods are lacking.
9. Metal-matrix composites are susceptible to unacceptable foreign object damage. One of the major obstacles or impediments to the use of composites (either resin-matrix or metal-matrix) in fan blades of turbo-fan engines is their reduced resistance to foreign object damage.

The fan blade, which is located at the front of a turbofan engine, is subjected to a wide variety of foreign objects that are ingested into the engine. Foreign objects commonly ingested fall into two major classes: (1) hard particle, including such objects as sand, rocks, rivets, bolts, ice balls and ice slabs; (2) soft body, including such items as tire treads and small, medium, and large birds.

It is unreasonable, of course, to expect a blade made of any material to encounter all classes of foreign object without sustaining damage. However, some objects such as sand, gravel, ice balls, and small birds are encountered so frequently that damage must be very slight for the blade to be economically feasible. The Air Force has no overall standard concerning foreign object damage. The FAA requirements are described in Circular AC 33-1B, which specifies that after ingestion, the engine must be capable of continued safe operation or be capable of being shut down safely.

Composite fan blades have not demonstrated sufficient FOD resistance to date to warrant being placed in service. Only a limited number of FOD tests have been conducted on full stages of composite blades, and in these, the damage caused by small birds ranged from slight to extensive. More numerous FOD tests

have been conducted on single blades and some of these have been quite encouraging. Birds weighing up to 2 pounds have been impacted, causing only slight damage to the blade. A large increase in toughness, as measured in an impact test, has been achieved by choosing a more ductile aluminum alloy, (5052) combined with larger fibers bonded at lower pressing temperatures. FOD testing of such blades is planned before the end of the year.

The state of the art of FOD of composite blades can be summarized as follows:

1. Composite blades can take hard particle objects with present leading edge protection
2. Composite blades have demonstrated the ability to ingest starlings in some cases; the damage has ranged from slight to extensive
3. There have been isolated successes in impacting birds up to 2 pounds with composite blades in single blade tests
4. Greater than 2-pound birds cause extensive damage to composite blades

Research in FOD of composite blades is currently being supported at a moderate rate by NASA, Air Force, Navy and industry internal research and development (IRAD) funds. In the past, most of the effort was of an empirical nature; blades and blade-like shapes were built and tested. Recently, there has been an increased emphasis on analytical approaches to FOD whereby analytical models describing the foreign object impact are formulated and then verified by carefully selected tests.

In summary, FOD is a major obstacle to the use of metal-matrix composites in the fan blades of turbo-fan engines. Various programs are currently under way to solve this problem and with sufficient effort there is a high probability that this problem can be solved; at least to the point that foreign object damage will be held to an acceptable level in metal-matrix composite blades.

## B. COST

High cost is the second major impediment to usage of metal-matrix composites. It springs from high filament, tape and fabrication costs and limited current demand. For example, the current cost of B/Al is \$180\* per pound; however, price projections for 1980, based on annual production of 200,000 pounds of boron filament are \$50 per pound for boron filament, \$51 per pound for B/Al tape, and \$60 per pound for B/Al plate. It is expected that costs of other metal-matrix composites also will decline significantly with increased production quantity (see Chapter VIII).

\*Summer 1974

## XI. DATA NEEDS

In the development of a new material, the first task is always to prove that one has a viable engineering material. During this stage, the properties and potentials of the material tend to be exaggerated and shortcomings overlooked to prove this point. The second task is to explore fully the characteristics of the material to detect and understand any kind of unusual behavior, (i.e. one must look for any and all reasons why the material "won't work"). All too often, this latter task is treated inadequately before the material is placed in service and catastrophic failures result because of some unexpected behavior of the material. Regarding metal-matrix composites, the first task mentioned above is nearly completed, and what must be ensured is that the second task is treated adequately.

Property data are used to predict the behavior of the material in actual service. In addition to the usual tensile, compressive, shear, and fatigue data commonly associated with design, more subtle properties must be known. The effect of the environment, other long-term effects, failure mechanisms, and, perhaps most important, how to nondestructively inspect the material (both before and while in service) must be known in order to prevent an unexpected and/or a catastrophic failure.

### A. DESIGN DATA

Design data are used by the designer to design parts for specific applications and/or to perform specific functions. Thus, design data must include material properties that can be translated into real parts operating in real service. Several factors are important in determining and collecting material properties that are adequate for design data; these include test methods, the statistical distribution of test results, the state of stress during test, scaling factors, load spectrums, etc.

At present, few if any standard test procedures are available for metal-matrix composites. Thus, standard procedures must be developed for the following:

1. Static mechanical properties--especially major elastic moduli and strengths; compression testing, in particular, needs standardization
2. Dynamic and time dependent properties such as fatigue and creep
3. Combined stress tests
4. Joint tests

These standard test procedures should be applicable for all temperatures from -40 °F (-40 °C) to at least 750 °F (400 °C) for B/Al and from -40 to at least 1200 °F (650 °C) for E<sub>SiC</sub>/Ti.

Except for tensile test data on B/Al, data on any type of metal-matrix composite are inadequate for design with any degree of reliability. The areas in greatest need of additional data are:

1. Combined states of stress--Biaxial and triaxial tests conducted over the entire stress envelope
2. Elevated temperature--Metal-matrix composites will be most competitive with other materials in applications where the temperature exceeds 390 °F (200 °C)
3. Reliability data
4. Dynamic and time dependent properties--these include high strain rate loading, fatigue, creep, etc.
5. Mechanical properties of joints--This is needed, particularly at elevated temperatures for all joining procedures

Eventually, sufficient data will be available to generate Mil Handbook 5 type allowances. However, until the number of composite systems is reduced to two or three (e.g., one aluminum-matrix and one titanium-matrix composite), this may not be economically feasible.

Other areas in need of additional work are:

1. The development and standardization of material specifications for B/Al and B<sub>SiC</sub>/Ti
2. The development of meaningful quality control tests and incorporation into the specifications
3. The development of relationships between coupon tests, subsize structural components, and structural component evaluations
4. The development of suitable design-criteria--Three different criteria presently are used for resin-matrix composites by three different contractors, and it is not known which, if any, of these criteria should be used for metal-matrix composites.

#### B. FAILURE PROCESSES

Failure processes must be studied if a basis for improving the static and dynamic properties and behavior of aluminum- and titanium-matrix composites is to be established. For instance, it must be determined whether composite failure takes place when the first few weakest fibers break or when sufficient fiber breakage has occurred and the remaining fiber segments are incapable of sustaining the load at that particular cross section. If the former is true and the composite fracture can be described as being noncumulative, efforts could and should be undertaken to rid the composite of low-strength fibers. According to one school of thought this could be accomplished by prestressing the material (and prebreaking the weak elements) prior to consolidation of the composite element. Alternately, if the failure process is indeed cumulative, prestressing would serve no useful purpose. A combination of the two mechanisms would of course lessen the impact of prestressing, the payoff of which would have to be weighed against its cost.

Understanding the failure process more thoroughly would allow the fabricator to tailor his consolidation parameters according to the particular end-

use environment of the part (i. e. , crack propagation in fatigue might best be delayed by altering the filament-matrix bond).

Although discussed in greater depth elsewhere in this report, the failure processes that control local composite failure after foreign object impact have not as yet been the subject of any study. Modeling of the various types of filament, matrix, and interface damage possibility, in light of their effect on adjacent structure, should provide valuable data on composite element properties needed to upgrade the resistance of the composite to impact.

In addition to providing the basis by which composites can be improved further, understanding the failure mechanisms will allow the developer to predict what the property limits of any composite system should be. Such beforehand knowledge will preclude the attempted development of otherwise attractive appearing systems.

The inspection of metal-matrix composites while in service will be greatly enhanced by a better understanding of the failure processes. Knowing how structural features change and/or how defects develop during the pre-initiation stages of failure will indicate both the frequency at which one should inspect and also for what one must inspect.

### C. NONDESTRUCTIVE TESTING FOR COMPOSITES

Generally, nondestructive testing (NDT) techniques are available for the detection of large gross type defects in composites. However, with the current interest in the use of composites for critical load-bearing aircraft structures, the NDT capability must be improved to ensure the necessary quality of composites. To satisfy this requirement, additional NDT development efforts must address the problems of:

1. Detecting and defining the significance of defects and their relationship to the performance of composites
2. Developing techniques for inspecting multilayered structures and integrating individual bondlines

3. Providing a capability for inspecting complex shapes
4. Overcoming the limitations of techniques to distinguish between a weak bond and a high strength bond

While it is important to improve the NDT techniques to detect defects, one also must be very well acquainted with the properties of the material and how those properties are affected by variations and defects within the material. Thus, in developing design data, the properties defined must represent what can be expected from routinely fabricated material. In so doing, one must categorize the influence of each defect or variable, defining its size, location, distribution, and influence on material property. Once categorized, limits of acceptance must be established (this may be a function of the application); these in turn define the levels to which nondestructive inspection techniques must be used to qualify the material (or component) for use. Defects that must be so evaluated are noted below (not prioritized or necessarily complete):

1. Unbonded areas
2. Missing fibers
3. Cross-over fibers
4. Poor spacing
5. Inadequate consolidation
6. Broken filaments
7. Foreign inclusions
8. Variation in volume fraction
9. Overreaction

All of the above, except for overreaction, can be detected to varying degrees with present techniques. However, the influence of all of these on the properties is not known.

#### D. ENVIRONMENTAL AND OTHER EFFECTS

Environmental effects on composites have not been investigated to any great depth. It generally has been assumed that the corrosion behavior of B/Al would be similar to Al and that of B<sub>SiC</sub>/Ti similar to Ti. Although this may be a logical assumption, the corrosive behavior of metal-matrix composites must be investigated fully. Of particular concern, is the effect of exposed edges, joints, and attachments on the corrosion behavior of these materials.

The effect of high-temperature environments is of particular interest with metal-matrix composites since they offer a definite advantage over resin-matrix composites in high-temperature applications. Such things as the effects of long exposure to high temperatures, thermal cycling, etc., should be fully explored.

Since many applications for metal-matrix composites will be in, around, and behind engines, sonic fatigue may be of critical concern. It is known that unidirectional resin-matrix composites have poor sonic fatigue resistance and that resin-matrix components must be crossplied in high-noise environments. While there is at present no indication that metal-matrix materials will not perform satisfactorily in a thermal/acoustical environment, the big question to be addressed is how will metal-matrix components perform as temperature and/or acoustical energy increases and what will limit and/or influence performance in this environment. For certain structural applications at lower temperatures the result of the level of acoustical energy on component performance needs to be determined.

Environmental testing, in general, is an area in need of improvement. Currently, materials and components are evaluated for acceptable performance by the trial-and-error technique, and a satisfactory rating is obtained if the component survives the specified exposure level and duration. Some areas in need of improvement involve:

1. Determining significant parameters for various anticipated environments (i.e., thermal, corrosive, etc.) and developing tests that measure the effects of these parameters
2. Developing real time and accelerated test procedures for environmental effects testing
3. Determining the relationship between lab tests and service

In summary, major emphasis should be placed on generating sufficient data with enough different tests to ensure that no major pitfalls will be encountered with the application of metal-matrix composites. It must be realized that this is a new material, vastly different from monolithic metals and only in some ways similar to resin-matrix composites, and that it is not safe to assume any characteristics without adequate testing.

## REFERENCES AND BIBLIOGRAPHY

1. Advanced Composite Design Guide, Vol. IV, Materials, 3rd Ed. (1973).
2. Brentnall, W. D., and Toth, I. J., "High Temperature Titanium Composites," AFML-TR-73-223, September 1973.
3. Brentnall, W. D., and Toth, I. J., "Off Axis Tensile Behavior of Al and Ti Matrix Composites" in Failure Modes in Composites, pp. 129-148. New York: AIME, 1973.
4. Bunk, W. "Dispersed Systems as Commercial Materials for Aerospace Applications" Journal of Metals, (May 1973): 26-32.
5. Cairo, R. P. and Torczyner, R. D., Graphite/Epoxy, Boron-Graphite/Epoxy and Boron/Aluminum Design Allowables, AFML-TR-72-232, December 1972.
6. Collins, B. R.; Brentnall, W. D., and Toth, I. J., "Properties and Fracture Modes of Borsic-Titanium" in Failure Modes in Composites, pp. 103-128. New York: AIME, 1973.
7. Doble, G. S.; Melnyk, P., and Toth, I. J. "Manufacturing Methods for Filamentary Reinforced Titanium Monotapes, Interim Engineering Reports 1 through 8, AFML Contract F33615-71-C-1690.
8. Donohue, P. J., and Mathisen, E. L., Composite Box Beam Optimization, Experimental Data Supporting Technology Development and Preliminary Design, AFML-TR-73-13, June 1973.
9. Donohue, P. J. et al, Composite Box Beam Optimization, AFML-TR-74-105 Volume I, May 1974.
10. Forest, J. D.; Fujimoto, A. F., Goelsch, G. F., et al Structural Development, Vol. 1 of Advanced Composite Applications for Spacecraft and Missiles, Phase I, Final Report. Technical Report AFML-TR-71-186, March 1972.
11. Forest, J. D. and Christian, J. L., "Space Structures," Applications of Composite Materials, ASTM STP 524, American Society for Testing Materials, 1973, pp. 134-162.
12. Gansler, J. R., "Acquisition Objective Changes from One of Sophistication to Reliability at Lower Cost," Defense Management Journal, July 1972, pp. 3-6.

13. Glasser, J.; Steurer, W. H., and M. A. Guenther, "The Basic Shape Concept," Chemical and Metallurgical Research, Inc., Chattanooga, Tenn., November 1967.
14. Hadcock, R. N., et al, Advanced Composite Wing Structures, AFML-TR-70-231, December 1970.
15. Haggerty, J. R., Production of Fibers by a Floating Zone Fiber Drawing Technique, NASA CR 120948 (1972).
16. Hoover, W. R.; Allred, R. E., and Schuster, D. M., "Development of a BORSIC-Aluminum Composite Ring Stiffener," Sandia Laboratories, Report No. SC-DR-720706, November 1972.
17. Juergens, R. J., "Generalized Cost-Weight Relationships for Composite Applications," McDonnell Aircraft Company, St. Louis, Mo., Communication presented to NMAB Ad Hoc Committee on Metal-Matrix Composites, May 9, 1973.
18. Korb, L. J., "Space Vehicles," Engineering Applications of Composites, Academic Press, 1973, Chapter 3.
19. Lundbert, B. K. O., "Fatigue Life of Airplane Structures," Eighteenth Wright Brothers Lecture, Journal of the Aeronautical Sciences, Vol. 22, No. 6, June 1956.
20. MDC Report EO825, "Design, Process Development, Manufacture, Test and Evaluation of Boron-Aluminum for Space Shuttle Components," July 30, 1973.
21. McQuillen, E. J., "Navy Advanced Composite Programs," AFML Advanced Composite Status Review, Cincinnati, Ohio, August 20-22, 1973.
22. Miller, M. F.; Christian, J. L. and Wennhold, W. F., "Design Manufacture, Development, Test, and Evaluation of Boron/Aluminum Structural Components for Space Shuttle, Volume 1, Design and Analysis," Report No. GDCA-DBG73-006 on Contract NAS 8-27738.
23. Noton, B., "Feasibility Study to Design Large, Traditionally Forged, Airplane Internal Structural Parts in Advanced Composite Materials" (Research Proposal Aero No. 18-68), Stanford University, Stanford, California, September 1968.
24. "Panel Reports of Composites Recast, an Air Force/NASA Long Range Planning Study," February 22, 1972.

25. Petrasek, High Temperature Strength of Refractory Metal Wires and Considerations for Composite Applications, NASA TN d-6881 (1972).
26. Schaefer, W. H., "Aluminum-Boron F-106 Engine Access Door Design and Test Evaluation," Convair Aerospace Division Report GDC-ERR-1514, August 1970.
27. Schaefer, W. H., Christian, J. L., et al., "Evaluation of the Structural Behavior of Filament Reinforced Metal-Matrix Composites, Volume II, AFML-TR-69-36, January 1969.
28. Scheirer, S. T. and Toth, I. J., "The Mechanical Behavior of Metal-Matrix Composites," AFML-TR-73-178, May 1973.
29. Scheirer, S. T.; Toth, I. J., and Menke, G. D., "The Time Dependent Mechanical Behavior of Metal-Matrix Composites," AFML-TR-72-149, September 1972.
30. Stusrud, R. W., et al., "Beryllium Reinforced Metal-Matrix Composites Study Program," EDR 7518, Final Report No. 00-19-71-C-0324, Detroit Diesel Allison Division, GMC, August 1972.
31. Swazey, E. H., and Wennhold, W. F., "Advanced Composite Technology Fuselage Program, Vol. III," Technical Report AFML-TR-71-41, November 1972.
32. Toth, I. J., "Comparison of the Mechanical Behavior of Filamentary Reinforced Al and Ti Alloys," Paper presented at Third Conference on "Composite Materials: Testing and Design," Williamsburg, Virginia, March 1973. (To be published by ASTM).
33. Weisinger, M. D., "Boron/Aluminum Composite Reinforced Gimbal Halves," GDCA Report ZZL-71-007, November 1971.
34. Wennhold, W. F., "Design and Fabrication of a Boron/Aluminum Composite Wing Box Test Specimen," Final Report on Contract N62269-72C-0414, NADC, July 1973.
35. Wennhold, W. F., "Evaluation of a Metal Fuselage Panel Selectively Reinforced with Filamentary Composites for Space Shuttle Application," Final Report on Contract NAS1-10766, NASA-Langley Research Center, September 1973.