

AD/A-006 497

TRAFFICABILITY TESTS WITH THE AIROLL ON
ORGANIC AND MINERAL SOILS

Army Engineer Waterways Experiment Station
Vicksburg, Mississippi

August 1961

DISTRIBUTED BY:

NTIS

National Technical Information Service
U. S. DEPARTMENT OF COMMERCE

080057

TRAFFICABILITY TESTS WITH THE AIROLL ON ORGANIC AND MINERAL SOILS

AD A 006497



MISCELLANEOUS PAPER NO. 4-439

August 1961

Reproduced by
NATIONAL TECHNICAL
INFORMATION SERVICE
US Department of Commerce
Springfield, VA. 22151

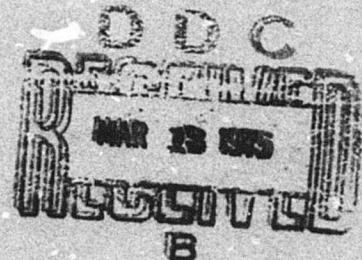

U. S. Army Engineer Waterways Experiment Station
CORPS OF ENGINEERS
Vicksburg, Mississippi

DISTRIBUTION STATEMENT A

Approved for public release;
Distribution Unlimited

U. S. ARMY ENGINEER WATERWAYS EXPERIMENT STATION
CORPS OF ENGINEERS
OFFICE OF THE DIRECTOR
VICKSBURG, MISSISSIPPI

COPY

REFER TO

WESSR

20 April 1961

SUBJECT: Draft of Report, "Trafficability Tests of the Airoll"

TO: Chief of Engineers
ATTN: ENGRD-S
Department of the Army
Washington 25, D. C.

1. Reference telephone conversation
2. A rough draft of the report "Trafficability Tests of the Airoll" is submitted for your comments and/or approval (inclosure 1). When your comments are received, they will be incorporated in the draft and the report will be sent to our Reproduction and Reports Branch for final editing and preparation for publication.
3. Inclosure 2 contains some

FOR THE DIRECTOR:

2 Incl
1. Dft of Airoll rpt
2. Comments

/s/
W. J. TURNBULL
Engineer
Chief, Soils Division

COPY

ENGRD-SE (20 Apr 61) 1st Ind
SUBJECT: Draft of Report, "Trafficability Tests of the Airoll"

HQ, DA, Office Chief of Engineers, Washington 25, D. C., 15 May 1961

TO: U. S. Army Engineer Waterways Experiment Station, Corps of
Engineers, Office of the Director, Vicksburg, Mississippi

1. The submitted "Airoll" report is approved subject to revision suggested by the following comments:

- a. It is deemed
- b. The desire to speak
- c. Informal discussion
- d. The term

2. It is requested

3. The recommendation

4. It is requested

FOR THE ACTING CHIEF OF ENGINEERS:

2 Incls
n/c

/s/
ROBERT F. JACKSON
Chief, Special Engineering Branch
Military Sciences Division
Research and Development

WESSR (20 Apr 61) 2d Ind

US Army Engineer Waterways Experiment Station, Vicksburg, Miss.

TO: Chief of Engineers, DA, Washington, D. C., ATTN: ENGRD-S

1. Revisions of the

2. Ingersoll has been

3. In view of the

4. Comparison of the

FOR THE DIRECTOR:

wd all incl

/s/ W. G. SHOCKLEY
Engineer
Acting Chief, Soils Division

ia

TRAFFICABILITY TESTS WITH THE AIROLL ON ORGANIC AND MINERAL SOILS



MISCELLANEOUS PAPER NO. 4-439

August 1961

U. S. Army Engineer Waterways Experiment Station
CORPS OF ENGINEERS
Vicksburg, Mississippi

ARMY-MRC V - VICKSBURG, MISS

THE CONTENTS OF THIS REPORT ARE NOT TO BE
USED FOR ADVERTISING, PUBLICATION, OR
PRCMOTIONAL PURPOSES

PREFACE

The trafficability tests with the Airoll reported herein were authorized by the Office, Chief of Engineers, in first indorsement, dated 8 August 1960, to a letter from the U. S. Army Engineer Waterways Experiment Station, dated 3 August 1960, subject, "Tests with Airoll Vehicle." The tests were conducted at Harts Lake, Fort Custer, Michigan, and at Warren Dunes State Park near Bridgman, Michigan, during the period 26 September-10 October 1960, and near Vicksburg, Mississippi, during the period 2-28 March 1961, by personnel of the Army Mobility Research Center under the general supervision of Mr. W. J. Turnbull, Chief of the Soils Division; Mr. S. J. Knight, Chief of the Army Mobility Research Center; and Mr. A. A. Rula, Chief of the Trafficability Section. Mr. E. S. Rush of the Trafficability Section supervised the field testing. This report was prepared by Messrs. Rush and Rula.

Acknowledgment is made to the Office of Naval Research for its part in making the Airoll available; to the U. S. Army Engineer District, Detroit for the loan of support vehicles; to personnel of Ingersoll Kalamazoo Division, Borg-Warner Corp., builders of the Airoll, for assistance and support during the tests; and to Mr. E. G. Bresson of Ingersoll who prepared Appendix A.

Director of the Waterways Experiment Station during conduct of the study and preparation of this report was Col. Edmund H. Lang, CE. Technical Director was Mr. J. B. Tiffany.

CONTENTS

	<u>Page</u>
PREFACE	iii
SUMMARY	vii
PART I: BACKGROUND, PURPOSE, AND SCOPE OF TESTS	1
PART II: DESCRIPTION OF AIROLL	2
General Features	2
Propulsion System	3
PART III: TEST PROGRAM	6
Location and Description of Test Areas	6
Soil Data	9
Tests Conducted	9
Test Procedures and Data Collected	10
PART IV: TEST RESULTS	13
Self-propelled Tests	13
Towing Tests	22
Towed Tests	25
Notes and Observations	26
PART V: CONCLUSIONS AND RECOMMENDATIONS	29
Conclusions	29
Recommendations	29
TABLES 1-3	
PLATES 1-8	
APPENDIX A: AIROLL SUSPENSION SYSTEM	A1
APPENDIX B: DETERMINATION OF VEHICLE CONE INDEXES FOR AIROLL OPERATION ON FINE-GRAINED SOILS	B1
Mobility Index	B1
Vehicle Cone Index	B3

SUMMARY

The Airoll is of interest in the Corps of Engineers mobility research program because of its new concept of locomotion which combines the free-rolling resilience of a pneumatic tire and the mobility of a laterally rigid track. The propulsion system is composed of free-rolling, low-pressure, pneumatic tires mounted on endless chains rotating about driving sprockets and return idlers. Weight of the Airoll is distributed over the tires, which also provide the suspension. The Airoll can move by means of two different and distinct types of action of the tires on the ground, termed rolling-wheel track and stationary-wheel track actions. The Airoll in its present state of development is a test platform equipped with the minimum requirements necessary for testing its particular locomotion concept under field conditions.

Trafficability tests with the Airoll were performed to determine its performance under off-road conditions. Self-propelled tests were conducted on level, highly organic soil and on level and sloping, fine- and coarse-grained mineral soils. Towing tests were conducted on most of the same soils. Towed tests were also conducted. Test results indicate that (a) the Airoll can travel on soft muck and wet fine-grained soil areas that no known military vehicle of equal weight can negotiate; (b) Airoll slope-climbing ability in clean sand is comparable to that of conventional tracked vehicles; (c) Airoll towing capabilities on firm soil are generally less than those of conventional tracked vehicles; (d) the force required to tow the Airoll is comparable to that required for conventional tracked vehicles; and (e) the rolling-wheel track and stationary-wheel track features of the Airoll permit it to achieve greater travel efficiency on most soil conditions than conventional tracked vehicles.

Appendix A contains a description of the Airoll principle prepared by one of the design engineers. Appendix B presents a detailed description of the determination of mobility indexes and vehicle cone indexes for the Airoll.

TRAFFICABILITY TESTS WITH THE AIROLL ON
ORGANIC AND MINERAL SOILS

PART I: BACKGROUND, PURPOSE, AND SCOPE OF TESTS

1. The Airoll, designed and fabricated by the Ingersoll Kalamazoo Division of Borg-Warner Corp. under Office of Naval Research Contract NOrn-2459(00), is of interest in the Corps of Engineers Army mobility research program because of its "entirely new concept of locomotion."* This concept combines the free-rolling resilience of a pneumatic tire and the maximum mobility of a laterally rigid track. The manufacturer states that the Airoll has unexcelled mobility under adverse conditions, will not damage improved road surfaces, and is of greatly simplified design.*

2. In order to investigate the performance of the Airoll under off-road conditions, the Office, Chief of Engineers, requested that arrangements be made with Borg-Warner and the Office of Naval Research to conduct trafficability tests of the self-propelled, towing, and towed type with the machine. The tests were performed in two phases: The first tests were made in muck, silty sand, and clean sand at two sites in Michigan, between 26 September and 10 October 1960. The second test series was performed in silt, silty clay, and sandy clay at Vicksburg, Mississippi, during the period 2-28 March 1961. The tests included measurement of Airoll performance in terms of minimum soil strength required for operation, as well as measurement of sinkage, slippage, drawbar pull, and rolling resistance on the range of soils mentioned above; a few towing tests were also made on an asphalt pavement.

* See Appendix A hereto, entitled "Airoll Suspension System," which was prepared by Ingersoll Kalamazoo Division of Borg-Warner Corp.

PART II: DESCRIPTION OF AIROLL

General Features

3. In its present state of development, the Airoll is a wheeled test platform equipped with the minimum features necessary for testing its special locomotion concept under field conditions; see figs. 1 and 2.



Fig. 1. Side view of Airoll

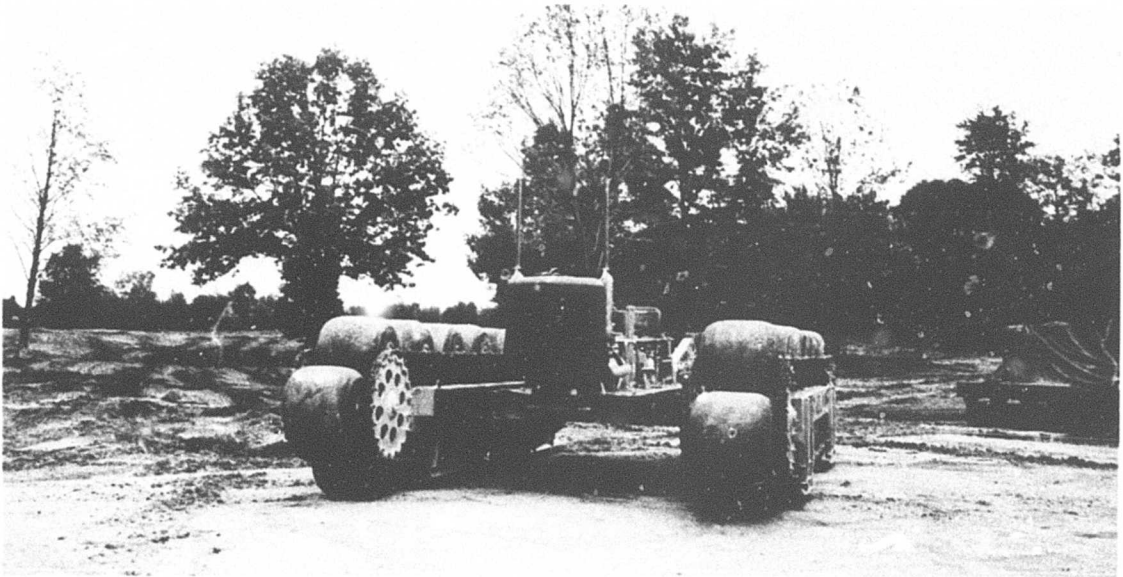

Fig. 2. Front view of Airoll

Pertinent data on the model used in these tests are as follows:

Weight, lb (approximate)	19,100
Length, ft	22.75
Width, ft	14.50
Tires:	
Size	24x24x6, 4-PR*
Type	terra
Tread	smooth
Nominal tire inflation pressure, psi	2 to 8
Number in contact with ground on each side	6 or 7
Total contact area, sq in.	
Tire prints	2,112**
Projected contact area	10,224†
Ground clearance, in.	26††
Engine horsepower, brake	185 at 2800 rpm
Vehicle cone index (VCI):	
Stationary-wheel track action (using projected contact area of track)	19‡
Rolling-wheel track action	43‡

* First number is outside tire diameter, second number is tire width, third number is rim diameter, and fourth number is ply rating.

** Measured on hard surface with 7 tires in contact with ground on each side; tire pressure was 8 psi.

† Length based on center-line distance between front and rear sprockets or 213 in. Width based on width of tires.

†† At 8-psi tire pressure.

‡ See Appendix B for computations of VCI.

A general description of the unique propulsion system of the Airoll is given in the following paragraphs; a more detailed explanation of the fundamentals of the system is included as Appendix A.

Propulsion System

4. The propulsion system is composed of free-rolling, low-pressure, pneumatic tires mounted on endless chains rotating about driving sprockets

and return idlers. The weight of the test platform is distributed over the tires, which also provide the suspension. In operation, the chains move the tires to the ground in front of the platform, and the platform then moves over the tires. Movement of the Airoll can occur in two different and distinct types of action of the tires on the ground, called rolling-wheel track and stationary-wheel track actions. Various combinations of the two actions also can occur.

Rolling-wheel track action

5. When the Airoll operates on a level or moderately sloping firm surface, the tires are made to roll beneath the platform by the tangential force being applied by the platform. In this case (rolling-wheel track action) the friction force (f) between the platform and the tires is greater than the total rolling resistance between the tires and the ground. The total rolling resistance is defined as the resistance caused by friction between the tires and the ground (r) plus that caused by the deformation of the ground (r'). In the rolling-wheel status, relative motion occurs between the chain (connecting the tires) and the ground. Each tire rotates on its own axis, and assuming no slip between the tires and the platform or ground, in one revolution of a tire the platform moves through a distance equal to twice the rolling circumference of the tire. This condition is illustrated in fig. 3.

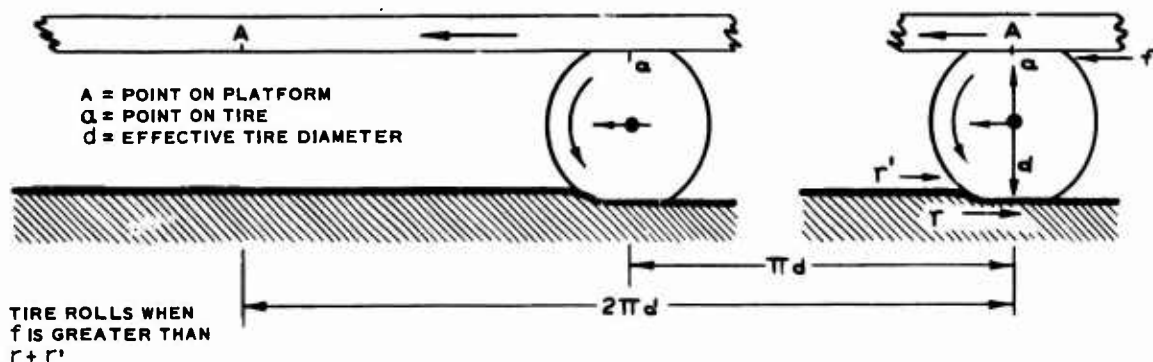

Fig. 3. Rolling-wheel track action

Stationary-wheel track action

6. In stationary-wheel track action, the Airoll moves much like a conventional tracked vehicle, i.e. the tires of the Airoll are carried forward by movement of the chain (track) around the sprocket, reach the ground,

TIRE ROTATES IN PLACE
WHEN f IS GREATER THAN
 r BUT LESS THAN $r + r'$

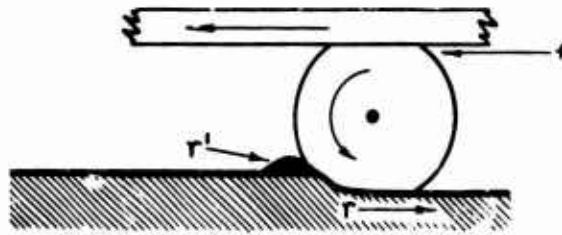

Fig. 4. Stationary-wheel track action, tire rotating in place

and remain in contact with the ground at the same place while the Airoll moves ahead. The tires themselves may rotate in place or remain stationary. They rotate in place when the frictional force between the platform and the tire is greater than the friction between the tire and the soil but less than the total resistance (see fig. 4). This condition occurs only occasionally when the soil surface is wet and slippery. The tires neither roll nor rotate when the force between the platform and the tire is less than that between the tire and the ground (see fig. 5). This condition usually occurs when rutting is relatively great.

TIRE NEITHER ROLLS NOR
ROTATES WHEN $r + r'$ IS
GREATER THAN f

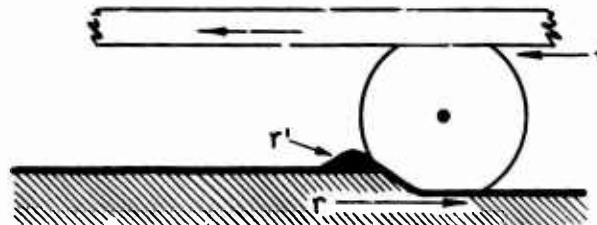

Fig. 5. Stationary-wheel track action, tire neither rolling nor rotating

Immobilization

7. Immobilization occurs when the force necessary to move the Airoll is greater than the shearing resistance of the soil; the tires are forced to slide beneath the platform, shearing the soil as they slide (fig. 6). In such a case of 100% slip, the tires usually do not rotate.

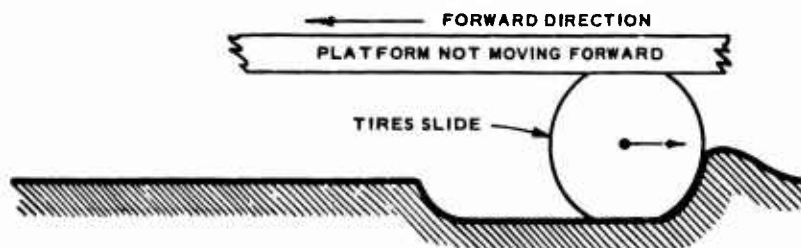

Fig. 6. Immobilization, tire sliding rearward

PART III: TEST PROGRAM

Location and Description of Test Areas

8. The test areas were located at Fort Custer Military Reservation near Battle Creek, Michigan, at Warren Dunes State Park on Lake Michigan near Bridgman, Michigan, and near Vicksburg, Mississippi. Locations of test areas are shown in plates 1 and 2.

Fort Custer, Michigan

9. At Fort Custer, the Airoll was tested on level, highly organic bottomland (muck) and level, upland silty sand on shallow moraine ridges. The muck test areas (fig. 7) were adjacent to Harts Lake and along a drain-
ageway leading from the lake. In these areas the ground water was near the surface, and the area supported a moderate growth of water-loving nonwoody plants. The muck exceeded 3 ft in depth, and in places was so soft a man could not walk on it; it exhibited little or no stickiness. The moraine ridges (fig. 8) tested were also adjacent to Harts Lake. In these areas the soil was firm and supported a sparse growth of grasses that were dormant during the period of testing.

Warren Dunes State Park, Michigan

10. The tests at the Warren Dunes State Park were conducted on the windward slopes of the dunes (fig. 9) and on the beach backshore (fig. 10). The dune sand was partially stabilized by vegetation except where the windward slopes were scoured by the wind. In these areas the windward slopes were bare and concave and sloped as much as 70%. The backshore was a level



Fig. 7.
Typical muck
test area,
Ft. Custer

area running parallel to Lake Michigan's edge. In both dune and backshore areas the soil was a clean, fine sand.

Fig. 8
Typical silty
sand test area,
Ft. Custer



Fig. 9.
Typical clean
dune sand
test area,
Warren Dunes
State Park

Fig. 10
Typical clean
beach sand
test area,
Warren Dunes
State Park



Vicksburg, Mississippi

11. Tests at Vicksburg were conducted in two mineral soil areas on the Waterways Experiment Station (WES) reservation and near the Port of Vicksburg a few miles north of the city.

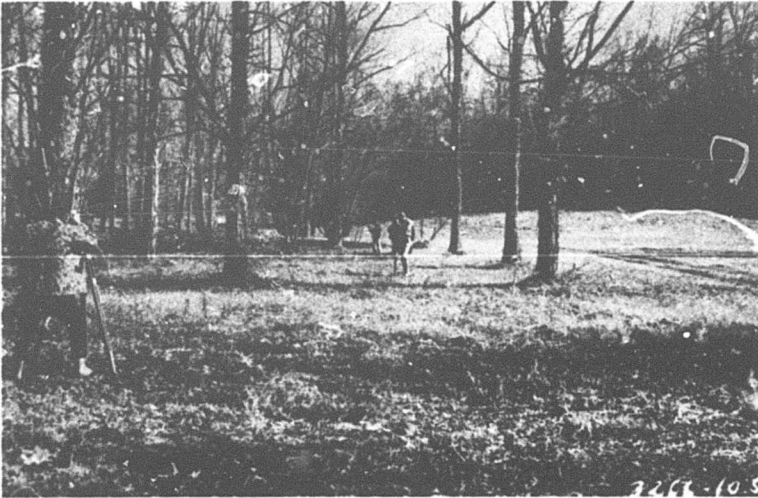

Fig. 11. Typical silt bottomland test area,
WES, Vicksburg

test lanes. Level upland and sloping areas were also tested, in which the soil was a silty clay.

13. At the Port of Vicksburg area tests were conducted on a soft, level, bare area (fig. 12) which was a borrow pit recently filled hydraulically with material obtained from a nearby canal. The area is subject to flooding during high stages of the Mississippi River. The soil classified as a sandy clay; however, it was stratified with



Fig. 12. Typical sandy clay test area,
Port of Vicksburg

12. The WES tests were conducted on soft, level bottomland areas adjacent to a small upland stream (fig. 11). The soil was a silt that had been partly washed down from the surrounding loessial hills and partly deposited by overflow from the nearby stream. There was very little vegetation on the

sandy clay and clay lenses. The soft soil extended to a depth of about 6 ft.

Soil Data

14. Gradation curves and supplementary data (Atterberg limits and Unified Soil Classification designations) for the mineral soils tested in Michigan and near Vicksburg are given in plates 3 and 4, respectively. Additional soil data (moisture content, dry density, etc.) for specific tests are contained in tables 1, 2, and 3. The highly organic (muck) soils tested contained approximately 28.4% organic material (on dry weight basis, determined by "loss by ignition" method) in the 0- to 12-in. depth. Liquid limit of the muck was about 130 and plasticity index was 63.

Tests Conducted

15. Self-propelled, towing, and towed tests were conducted with the Airoll, and with three conventional vehicles (weasel, D7 tractor, and Tournadozer) for purposes of comparison. The test areas used for the three types of tests were as follows:

Type Test	<u>Fort Custer</u>			<u>Vicksburg, Miss.</u>			<u>Warren Dunes</u>		
	Level Muck	Level Silty Sand	Level As-phalt	Level Sandy Clay	Level Silty Silt	Level Silty Clay	Slope, Silty Clay	Slope, Clean Sand	Level Clean Sand
Self-prop.	X			X	X		X	X	
Towing	X	X	X			X			X
Towed	X	X	X			X			X

Self-propelled

16. In the self-propelled tests on level terrain, the Airoll was run back and forth in the same path until it became immobilized or until it had completed 40 to 50 passes and immobilization was not imminent. In the self-propelled tests on sloping terrain, the Airoll was run up each slope, as far as it could climb or to the top, once. In the tests at Warren Dunes tire pressures of 5, 10, and 15 psi were used; for all tests except those at Warren Dunes, 8-psi tire pressure was used.

Towing

17. In the towing tests, the Airoll towed a vehicle at a speed of approximately 2 mph to determine the maximum drawbar pull that the Airoll

could develop on the first pass. At Fort Custer and Warren Dunes, drawbar pull-slip tests were conducted; at Vicksburg, only maximum drawbar pulls were determined. In the drawbar pull-slip tests, drawbar pull and slip were increased by gradually increasing brake pressure of the load vehicle.

Towed

18. In the towed tests, the Airoll was pulled in neutral gear to determine the force required to tow it on the same surfaces utilized in the towing tests.

Test Procedures and Data Collected

Self-propelled tests

19. In the level muck test area, test lanes 100 ft long were staked out and the cone index of the soil was measured, usually at 5-ft intervals, along the proposed center line of the vehicle path at the surface and at 3-in. vertical increments to a depth of 24 in. Two remolding tests were run on samples taken from the 6- to 12-in. depth near the point where the lowest cone index was measured. Samples for moisture-content and density determinations were taken from the 0- to 6-in. and 6- to 12-in. depths at each remolding index station. (Fig. 13 shows a moisture-density sample



Fig. 13. Moisture-density sampling in muck

being taken. At times difficulty was experienced in obtaining samples with the trafficability sampler* because of the extremely high water content and fibrous nature of the muck.) Traffic with the Airoll was then started. Rut depth and cone index of the soil in the ruts were

* For description of trafficability sampler see Waterways Experiment Station Technical Memorandum 3-240, 3d Supplement, Trafficability of Soils; Development of Testing Instruments (October 1948).

measured at varying intervals during the course of each test. Observations were recorded of the behavior of the soil and Airoll during each test.

20. In the level, silt and sandy clay areas, test lanes 100 ft long were staked out and cone index of the soil was measured at 10-ft intervals along the proposed center line of each track at the surface and at 3-in. vertical increments to a depth of 36 in. Two remolding tests (one in each proposed track) were made on samples taken from the 6- to 12-in. depth near the point where the lowest cone index was measured. Samples for moisture-content and density determinations were taken from the 6- to 12-in. depths at each remolding station. Rut depth and cone index of the soil in the ruts were measured as in the muck soil tests. Observations were made of the behavior of the soil and Airoll during each test.

21. For the sloping-terrain areas, soil data were collected after the Airoll test. If the Airoll was immobilized, data were measured along both of its sides. If it negotiated the slope, data were collected adjacent to the test lane on the steepest section of the slope. The data were collected outside the zone of disturbance by the vehicle and are considered to be "before-traffic" data for analysis purposes. Cone index measurements were made in the same manner as described in the preceding paragraph except that five sets of cone index measurements were made along both sides of the Airoll and to a depth of 18 in. or to the depth at which the capacity of the cone penetrometer (300) was reached. Representative moisture-content samples for the 0- to 6-in. and 6- to 12-in. depths were usually obtained. Density was not measured but was estimated to be 85 to 90 lb per cu ft for the sand and silty clay soils. Tire inflation pressures and slopes were measured carefully for each test. Pertinent notes were made concerning the behavior of the soil and the Airoll during each test.

Towing tests

22. Measurements of drawbar pull and track slip were made for each towing test conducted in muck, silty sand, and clean sand. Maximum drawbar pull measurements only were made on silty clay and asphalt pavement. Cone index, remolding index, and moisture-content data were collected during the muck tests in the same manner as for the self-propelled tests (paragraph 19). Cone index only was measured for the silty clay, silty sand, and clean sand tests.

23. To measure drawbar pull, a Baldwin load cell was attached to a 30-ft-long cable extending from the Airoll to a load vehicle. Once the combination attained a steady speed (1 to 2 mph) the load vehicle gradually applied its brakes until the maximum drawbar pull was achieved. By means of necessary electrical and electronic equipment, continuous inked records of drawbar pull and distances that the Airoll and track traveled (for slip computations) were obtained simultaneously. When a conventional vehicle moves forward at no slip, the distance that a point on the periphery of its track (or wheel) moves in space is equal to the distance that the vehicle moves along the ground. Finite slips are computed according to the expression

$$\% \text{ slip} = 100 \times \frac{\text{dist traveled by track or wheel} - \text{dist traveled by vehicle}}{\text{dist traveled by wheel or track}}$$

The distance traveled by a conventional vehicle cannot be greater than that traveled by a point on the track or wheel (unless the vehicle is sliding downhill or being towed), and thus slip cannot be negative. The Airoll platform, however, actually moves twice the distance that the track chain moves in the same time period when it is operating with rolling-wheel track action, and in this case, slip, according to the above expression, is -100%. When the Airoll first begins to operate with stationary-wheel track action, it moves the same distance as the track chain, and slip is zero. All conventional vehicles are said to be undergoing 100% slip when wheels or tracks are spinning but the vehicle is making no progress.

Towed tests

24. Towed tests were conducted in a section of the same test areas used in the towing tests. The soil property measurements made for the towing tests are also applicable to the towed tests. Continuous inked traces of the force required to tow the Airoll at speeds from 1 to 2 mph in soil and on asphalt pavement were obtained in the same manner as in the towing tests.

PART IV: TEST RESULTS

Self-propelled TestsLevel terrain

25. The principal purpose of the self-propelled tests conducted in soft, level, highly organic and mineral soils was to determine experimentally the vehicle cone index (VCI)* of the Airoll, and compare it with the computed VCI. The VCI is the minimum rating cone index required for a vehicle to negotiate 40 to 50 passes in a straight-line path. The VCI computations for the Airoll are given in Appendix B. Because level clean sands can be negotiated easily by tracked vehicles and most all-wheel drive wheeled vehicles at low tire inflation pressures, performance in sand usually is measured in terms of slope-climbing ability.

26. The critical soil layer for vehicles that weigh the same as the Airoll, operating in highly organic soils, fine-grained mineral soils, and sands with fines, poorly drained, is the 6- to 12-in. depth;* and the critical layer for clean sand for all vehicles is the 0- to 6-in. depth.** The analysis of soil strength data is therefore based on these depths for the respective soils.

27. Muck. Five tests were conducted in noncohesive muck; four resulted in nonimmobilization and one in immobilization. Test results are summarized in table 1 and are shown graphically in the upper portion of fig. 1 of plate 5. In the four nonimmobilization tests, the vehicle experienced no difficulty in completing the 40 passes. In the one immobilization test (test 5), the Airoll completed 20 passes before becoming immobilized when the ruts created were about 3 ft deep (see fig. 14). In all muck tests the Airoll track performed as a stationary-wheel track, i.e. the tires remained stationary and the platform slid across the top of the tires. During the immobilization test the tires sheared the soil as they entered it and pushed the material to the rear as the track chains lifted

* Waterways Experiment Station Technical Memorandum No. 3-240, 14th Supplement, Trafficability of Soils, A Summary of Trafficability Studies Through 1955 (December 1956).

** Waterways Experiment Station Technical Memorandum No. 3-240, 15th Supplement, Trafficability of Soils, Tests on Coarse-Grained Soils with Self-propelled and Towed Vehicles, 1956 and 1957 (June 1959).



Fig. 14. Airoll immobilized in muck soil on 21st pass (test 5, table 1)

the tires out of the soil. In the other four tests, although no shearing of the soil occurred, a mixture of water and muck flowed into the ruts after each pass.

28. Silt and sandy clay. Ten tests were conducted in silt and sandy clay soils; in six the Airoll experienced no difficulty in making 50 passes, in two it experienced moderate difficulty but was not immobilized, and in two immobilization occurred. Test results are summarized in table 1, tests 6 through 15, and are shown graphically in the lower portion of fig. 1 of plate 5. In tests where the Airoll experienced no difficulty, tests 6 through 10, it performed as a rolling-wheel track for the first few passes; thereafter it performed as a stationary-wheel track. After a few passes the tires fitted into a "rack" that had developed as a result of the tires hitting the ground at the same spots on each pass (see fig. 15). Attempts were made to place the tires on the crests between pockets, but after a few feet the tires would slip into the already-formed pockets and travel as before. In tests where some difficulty was encountered (tests 11 and 12), the Airoll performed entirely as a stationary-wheel track; and when the frame began dragging, usually after 25 passes, slippage of the track sheared the rut ridges and continuous ruts with a uniform rut surface were developed as shown in fig. 16. After about 45 passes and when high slip

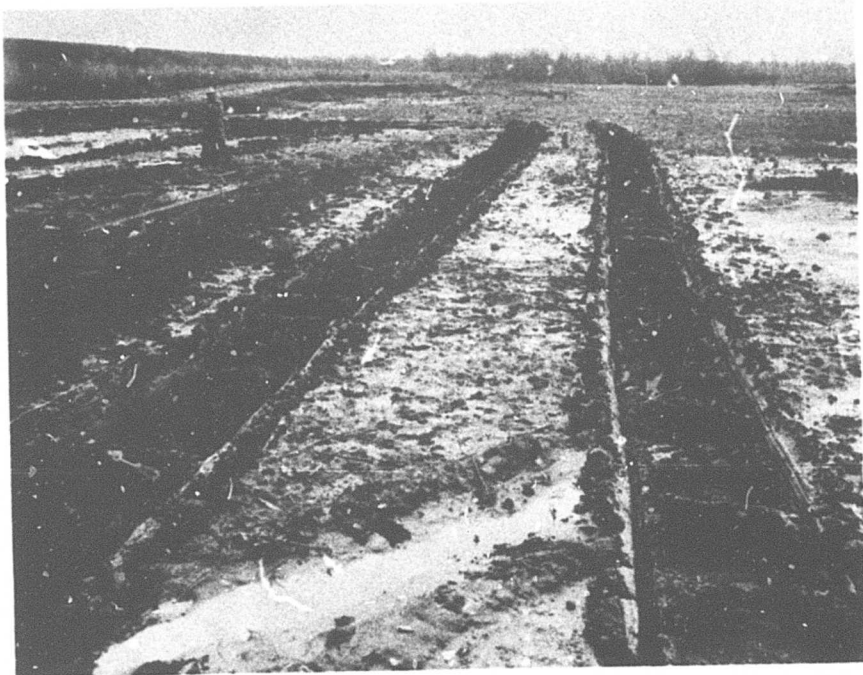

Fig. 15. Airoll rut pattern after ten passes in soft sandy clay (test 11, table 1). When Airoll operated with little or no track slip, pockets were formed by the tires



Fig. 16. Airoll rut pattern after 25 passes in soft sandy clay (test 11, table 1). Track slip has sheared the ridges shown in fig. 15

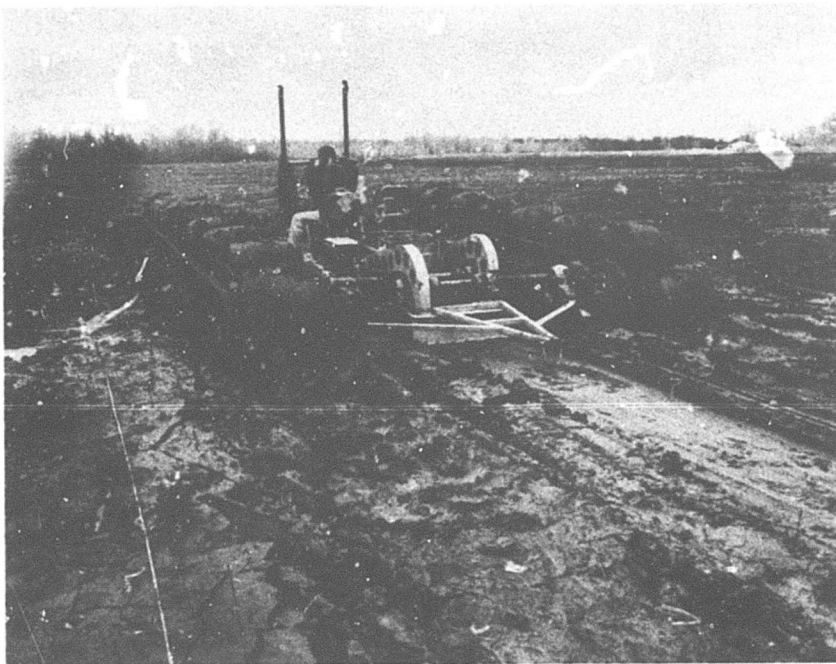

Fig. 17. Airoll rut pattern after 45 passes in soft sandy clay (test 11, table 1) after very high slip had occurred. The soft soil discharged behind the Airoll filled the ruts

on the ninth pass and high slip occurred on the tenth pass (see fig. 18). The Airoll was considered to be immobilized on the eleventh pass (see fig. 19), although it was actually moving forward a few inches with each complete cycle of a given tire around the platform. The rear of



Fig. 18. Airoll on tenth pass (in reverse) in soft sandy clay (test 14, table 1). Note the adhesion of soil to the Airoll's running gear

was occurring, the Airoll discharged soil behind it, filling the ruts as shown in fig. 17; the cone index of the soil in the ruts was 5 to 10 to a depth of 24 in. The cone index on which the Airoll was actually traveling ranged from 20 to 30. In the immobilization test (test 14) the frame was dragging



Fig. 19. Airoll immobilized in soft sandy clay on eleventh pass (test 14, table 1)

the platform was 6 in. below ground surface when the test was halted.

29. Comparison of experimental and computed VCI's. In the determination of the experimental VCI of the Airoll, highly organic and fine-grained mineral soils were considered together. The experimental and computed VCI's are shown as vertical lines in fig. 1 of plate 5. The line drawn at rating cone index (RCI) 15 separating immobilizations from nonimmobilizations in the referenced figure is the experimental VCI for the Airoll. This is 4 RCI points lower than the computed VCI. Because of frequent mechanical failures of the power train when the Airoll was operating in fine-grained mineral soils at strengths near 15 RCI, tests were not actually conducted on soils with RCI's between 13 and 23. However, from observations of the difficulties experienced in tests 11 and 12 on RCI's of 23 and 25, respectively, it is believed that the computed VCI (19) for the Airoll is valid for mineral soils, and allows the small margin of safety inherent in computed VCI's.

30. An examination of the remarks in table 1 for tests 1, 3, and 4, conducted in the highly organic (muck) soil, reveals that at RCI's of 16, 15, and 15, respectively, the Airoll completed a large number of passes

with ease. However, the remarks in table 1 for tests 11 and 12, conducted in fine-grained mineral soils, indicate that at RCI's of 23 and 25, respectively, the Airoll experienced difficulties. Experience has shown that the RCI required for a vehicle is generally the same in all fine-grained soils. The one exception noted thus far is for the M29C weasel. This vehicle has a tendency to collect mud between the top of the track and the body, which may cause it to become immobilized in sticky soil which it could otherwise negotiate. The weasel, which has actually been observed to negotiate successfully a nonsticky fine-grained soil with an RCI of approximately 10, has become immobilized in a sticky soil with a 20 to 25 RCI. Consequently, the weasel has been evaluated as requiring 20 to 25 RCI (depending on its actual weight, etc.). Following the same general reasoning and the trend indicated by results of these tests, it is possible that a vehicle may have different VCI requirements in nonsticky muck than in sticky mineral soils. Analysis of the data with these considerations in mind suggests the possibility of a minimum RCI requirement of 15 for the Airoll operating in highly organic soil, and of 19 for operation in fine-grained sticky soils.

31. Comparison of performance of Airoll and weasel. Self-propelled tests were conducted with an M29C weasel in sandy clay and muck soils; one sandy clay and eight muck tests were run. Data from these tests are summarized in table 1, tests 16 through 24, and a plot of the RCI data for the critical layer (3 to 9 in.) is shown in fig. 2 of plate 5.

32. Of the eight muck tests two resulted in immobilizations and six in nonimmobilizations; the one test conducted in sandy clay resulted in an immobilization. As had the Airoll, the M29C weasel performed better than indicated by the computed VCI (23). In this case, the experimentally determined VCI was 15, 8 points lower than the computed VCI.

33. The Airoll and the weasel appeared to have about the same capability for negotiating the soft soils. On the basis of a comparison of the computed VCI's and the better track-cleaning characteristics of the Airoll, it is believed that the performance of the Airoll is slightly better in soft sticky soils (RCI's 15 to 30) than that of the weasel.

34. Slipperiness tests. Level fine-grained soils that have adequate strength to support a vehicle but are covered with water or a thin layer of soft soil usually are slippery, and immobilization of vehicles,

particularly wheeled vehicles, can occur therein in some instances. In such instances, the vehicle merely spins its wheels without either sinking excessively or moving forward. Tests 7 and 8 (table 1) were conducted with the Airoll in an area that exhibited conditions of slipperiness. In these tests the Airoll performed partially as a rolling- and partially as a stationary-wheel track for the first few passes. After the first few passes pockets formed along the rut surface, causing the Airoll to operate as a stationary-wheel track only. During the stationary-wheel track action the slipperiness condition caused all the tires on the ground to rotate in place as the platform slid forward. From the test results it is apparent that slipperiness conditions on level ground presented no difficulties for the Airoll.

Sloping terrain

35. Clean sand. Tests were conducted on a range of sand strengths on bare, clean sand slopes at Warren Dunes State Park to determine the slope-climbing ability of the Airoll (fig. 20). In a typical test run, the Airoll began its climb as a rolling-wheel track. At some point during its climb, the Airoll shifted from rolling- to stationary-wheel track action and



Fig. 20. Airoll slope-climbing test at Warren Dunes State Park. Arrow indicates change from rolling-wheel to stationary-wheel track action

continued to climb until the steepness of the slope finally immobilized it. For each test run, test lanes were marked to identify the maximum slope on which the Airoll operated as a rolling- and as a stationary-wheel track,

and the slope on which it was immobilized. Thus, one run up a slope usually provided several tests.

36. Fifty tests were conducted on the sand slopes at three tire inflation pressures. Eleven tests were run at 15-psi tire inflation pressure, 23 at 10 psi, and 16 at 5 psi. Test results are summarized in table 2, and slope-cone index plots are shown graphically in plate 6.

37. Figs. 1, 2, and 3 of plate 6 show the slope-climbing performance of the Airoll at 15-, 10-, and 5-psi tire pressures, respectively. The curves drawn separate the immobilizations from nonimmobilizations. The top curve in each figure indicates the performance of the Airoll as a stationary-wheel track, and the bottom curve indicates its performance as a rolling-wheel track. It is to be noted in fig. 3 of plate 6 that items 37 and 39 represent immobilizations that plot on the "wrong" side of the performance curve. These two tests were conducted during a light rain which wetted the tires and the surface of the sand. The wetting caused sand to adhere to the tires, thus resulting in a decrease in the tangential force developed between the tires and the Airoll platform. It is believed that on dry to moist sand the performance of the Airoll at 5-psi tire pressure would be equal to the performance indicated by the curve. From the summary curves shown in fig. 5 of plate 6, it can be seen that the slope-climbing ability of the Airoll operating as a rolling-wheel track increased as tire pressure decreased, whereas for its stationary-wheel performance the reverse was true.

38. Fine-grained soil. Five tests were conducted on silty clay slopes covered with a heavy spring growth of grasses and weeds about 6 in. high, during different wetness conditions, to determine the slope-climbing ability of the Airoll on fine-grained soil slopes. The slope surfaces were smooth and the grade was uniform throughout the length of the slope. One test was conducted when the vegetation surfaces and litter were dry, and four were conducted following a heavy rain that wetted the vegetation, litter, and surface soil layer. During the wet-surface tests some free water drained down the slope. The results of these tests are summarized in the tabulation on the following page.

Slope %	Immobi- lized	Before-traffic		Remarks
		Cone Index	0- to 6-in. Depth	
47	No	---		Grass was not wet
47	Yes	60		Wet grass
41	Yes	107		Wet grass
38	No	58		Wet grass, some difficulty
38	No	110		Wet grass, no difficulty

This tabulation reveals that the Airoll could climb at least a 47% slope (the maximum slope available) when the surface was clear of free water and the strength of the soil was more than adequate to support it; however, when the slope was wet, regardless of soil strength, the Airoll could climb only a 38% slope. When the Airoll could not climb the wet slopes, the tires were wet causing the friction between them and the platform to become less than the friction between the tires and the ground. When this occurred the force imparted to the tires by the track chains, which acted parallel to and down the slope when the vehicle was attempting to move forward (i.e. up the slope), caused the tires to roll down the slope, thus moving the vehicle backward.

39. Comparison of performance of Airoll and other vehicles. In plate 6, fig. 5, comparisons are made of performance of the Airoll in clean sand with the performance of the weasel, Jumbo 4x4 truck, and a military M135 2-1/2-ton, 6x6 cargo truck. The weasel and Jumbo (18.00-26, 10-PR tires; weight 21,100 lb) were tested at Warren Dunes (the Jumbo tests were part of another test program); weasel test data are summarized in table 2, tests 51 through 59, and Jumbo truck test data are published in the report on the Jumbo tests.* The performance curve for the M135 2-1/2-ton truck (11.00-20, 12-PR tires; weight 18,700 lb) was also extracted from another report.** The cone index-slope curve for the weasel, developed from the data collected at Warren Dunes, is given in fig. 4 of plate 6.

40. From the upper set of curves in fig. 5 of plate 6 it can be seen

* U. S. Army Engineer Waterways Experiment Station, CE, Trafficability Tests with Jumbo Truck on Organic and Coarse-Grained Mineral Soils, Miscellaneous Paper No. 4-438 (Vicksburg, Mississippi, July 1961).

** See Waterways Experiment Station Technical Memorandum 3-240, 15th Supplement.

that the Airoll's slope-climbing ability as a stationary-wheel track at tire pressures of 10 and 15 psi appears to be better than that of the weasel; however, at 5-psi tire pressure the slope-climbing ability of the Airoll is less than that of the weasel. The lower set of curves in fig. 5 of plate 6 shows that the slope-climbing ability of the Airoll as a rolling-wheel track is similar to that of conventional wheeled vehicles. At 15- and 10-psi tire pressures, the Airoll climbed slopes slightly steeper than those climbed by the M135 2-1/2-ton cargo truck mounted with 11.00-20, 12-PR tires inflated to 10-psi tire pressure. At 5-psi tire pressure the Airoll's slope-climbing performance equaled that of the Jumbo truck mounted with 18.00-26, 10-PR tires inflated to 10-psi tire pressure.

41. Tests were conducted with the weasel on the same fine-grained soil slopes utilized for the Airoll tests at Vicksburg (see paragraph 38). The weasel negotiated the maximum slope (47%) with ease even when the slope surface was wet.

Towing Tests

Drawbar pull-slip tests

42. Muck. Seven drawbar pull-slip tests were conducted in muck at 8-psi tire pressure; the data are summarized in table 3, and are shown graphically in fig. 1, plate 7. The soft muck permitted the Airoll to operate only as a stationary-wheel track; therefore, the drawbar pull-slip curve starts at approximately 0% slip (see paragraph 23). Ruts were approximately 12 in. deep without a drawbar load; however, they did not increase significantly as drawbar pull-slip increased. Two weasels were used as load vehicles, but they were able to provide drawbar pull of only approximately 25% of the Airoll's weight. To measure drawbar pull at higher slips, an amphibious LVP5 was used as a load vehicle; it operated on firm soil and was attached to the Airoll by a 200-ft-long cable.

43. From examination of the drawbar pull-slip curves in fig. 1, plate 7, it can be seen that drawbar pull increased sharply between -10 and +10% slip but increased slightly at higher slips.

44. Silty sand. Sixteen drawbar pull-slip tests were conducted in silty sand at 8-psi tire pressure; the data are summarized in table 3,

tests 8 through 23, and are shown graphically in fig. 2, plate 7. For all tests, the soil was firm (300+ cone index at 1 to 2 in. below the surface) with a thin layer of loose sand and some dry grass on the surface. Fig. 2 of plate 7 shows that on silty sand the Airoll developed a drawbar pull when operating with either rolling- or stationary-wheel track action; the lower curve (-100 to approximately 0% slip) represents the Airoll's drawbar pull-slip performance with rolling-wheel track action, and the upper curve (approximately 0 to 100% slip) represents its performance with stationary-wheel track action. The Airoll was able to develop a maximum drawbar pull of about 35% of its weight at -40% slip in rolling-wheel track operation and about 52% of its weight at 100% slip in stationary-wheel track operation. Rut depths were shallow, averaging about 1 in. even for the high drawbar pull-slip test conditions.

45. Clean sand. Thirteen drawbar pull-slip tests were conducted on clean sand at 5-psi tire pressure; results of these tests are summarized in table 3, tests 24 through 36, and are shown graphically in fig. 3, plate 7. Cone index for the 0- to 6-in. depth was 64. Two curves are again drawn to represent rolling- and stationary-wheel track performances. The Airoll developed a maximum drawbar pull of approximately 24% of its weight at -20% slip in rolling-wheel track operation, and 50% of its weight at 100% slip in stationary-wheel track operation. From a comparison of the slope-performance curves given in fig. 5 of plate 6 it is apparent that the maximum drawbar pull of the Airoll with stationary-wheel track action would have been greater if tested at tire pressures of 15 and 10 psi.

46. Effects of soil type on Airoll drawbar pull-slip relations. A summary of the drawbar pull-slip performance of the Airoll operating on the three soil types tested is shown in the family of curves given in fig. 4 of plate 7. In the soft muck (RCI 43) the Airoll could operate only with stationary-wheel track action, giving its poorest performance. The curves resulting from the tests on the silty sand (cone index 300+) and clean sand (cone index 64) are similar, except the curve for the clean sand lies lower on the ordinate as a result of that sand's lower strength.

Maximum drawbar pull tests

47. Silty clay. Two series of tests were conducted on silty clay soil at WES. The first series of tests (tests 61-63, table 3) was run on a

nearly bare, firm soil (cone index of 300+ at 1 to 2 in. below the surface) with a thin surface layer of dry silt. In these tests the Airoll developed a maximum drawbar pull of 68.1% of its weight as it approached 100% slip. At continuous 100% slip the drawbar pull increased to 75.9% of the Airoll's weight. The maximum drawbar pull that the Airoll could develop at a speed of approximately 1 mph was 58.9% of its weight. The second series of tests (tests 70 and 71, table 3) was conducted in the same area after a heavy rain had wetted the soil to a depth of 2 in. Below 2 in. the soil was almost as firm as it was before the rain, but cone index in the 0- to 2-in. depth was reduced to 60. In these tests the Airoll developed a maximum pull of 27.5% of its weight as it approached 100% slip; its maximum drawbar pull at a speed of approximately 1 mph was 24.9% of its weight.

48. Asphalt pavement. Several maximum drawbar pull tests were conducted with the Airoll at 8-psi tire pressure on smooth asphalt pavement. The average maximum drawbar pull was 68% of the Airoll's weight; estimated slip ranged from 75 to 100%. At maximum drawbar pull the bottom of the tires deformed considerably, and during one run a power-drive chain was broken.

Comparison of performance of Airoll and other vehicles

49. A few drawbar pull-slip tests were run with the M29C weasel in muck and silty sand to compare its drawbar pull and slip performances with those of the Airoll. A summary of data for the weasel tests is given in table 3, tests 37-60. Comparison of drawbar pull-slip curves for the Airoll and the weasel for the muck and silty sand are shown in figs. 1 and 2 of plate 8, respectively. The curves for the Airoll represent its performance only as a stationary-wheel track (tires not rolling). In terms of percentage of vehicle weight, the curves show that the weasel developed a maximum drawbar pull approximately 11% greater than that developed by the Airoll in both muck and silty sand. The weasel developed its maximum pull at or near 100% slip, whereas the maximum pull developed by the Airoll was at approximately 80% slip in muck and approximately 100% in the silty sand.

50. Maximum drawbar pull tests with a Tornadozer 4x4 wheeled tractor and a standard D7 engineer crawler tractor were conducted in the same silty clay soil area in which the Airoll was tested and under the same soil

wetness conditions (see paragraph 47). These tests were made to compare the maximum drawbar pull that the Airoll, the Tournadozer, and the D7 tractor could develop traveling at a speed of approximately 1 mph on soil conditions normally encountered in earth-moving work. Test results are shown in table 3, tests 61-75, and a summary of the results (when the vehicles traveled at a speed of 1 mph) is shown in the following tabulation.

<u>Vehicle</u>	<u>Weight lb</u>	<u>Maximum Drawbar Pull (% of Vehicle's Weight) at Speed of Approx. 1 mph</u>	
		<u>Firm Surface</u>	<u>Soft Surface</u>
Airoll	19,100	58.9	24.9
Tournadozer	30,100	66.4	20.6
D7 tractor	32,000	84.4	37.5

It can be seen that the D7 crawler tractor developed a much greater drawbar pull than the Airoll or Tournadozer on the two surfaces. The D7 tractor's aggressive grouser action developed traction beyond the capacity of its engine at 100% slip on the firm surface. The Airoll's performance on the firm surface was less than that of the Tournadozer, but on soft surfaces the Airoll's performance was better than that of the Tournadozer. The Tournadozer tires were badly worn but had sufficient tread for some grouser action.

Towed Tests

Airoll tests

51. Towed tests were conducted to determine the amount of force necessary to tow the Airoll on pavement and on a range of soil conditions.

The test results are summarized in the following tabulation.

<u>Test Surface</u>	<u>Before- traffic Cone Index</u>	<u>Depth in.</u>	<u>Tire Pres- sure psi</u>	<u>Rut Depth in.</u>	<u>Force Required to Tow Airoll on First Pass % Airoll Weight</u>
Muck	32	0-12	8	12	11.0
Muck	37	0-12	8	12	9.7
Silty sand	300+	0-3	8	0	6.3
Clean sand	64	0-6	5	1	6.6
Silty clay, firm	300+	0-2	8	0	5.5
Silty clay, soft	60	0-2	8	2	15.8
Asphalt pavement	---	---	8	0	4.7

It can be seen that the force required to tow the Airoll ranged from 15.8% of the Airoll's weight when it was towed on a soft silty clay surface to 4.7% of its weight when it was towed on asphalt pavement, with intermediate values for the tests on the other types of surfaces. Although the rut depths were much shallower in the soft silty clay surface than in the muck, the silty clay soil "balled up" on the tires causing the force required to tow it to be higher than in the nonsticky muck. In the muck the Airoll merely compressed the soil, and water filled the depressions.

Comparison of performance
of Airoll and other vehicles

52. For purpose of comparison, similar towed tests were conducted with the weasel, Tournadozer, and D7 tractor in several of the areas in which the Airoll was tested. Results of these tests are summarized in the following tabulation.

<u>Vehicle</u>	<u>Test Surface</u>	<u>Before- traffic Cone Index</u>	<u>Depth in.</u>	<u>Rut Depth in.</u>	<u>Force Required to Tow Vehicle on First Pass % Vehicle Weight</u>
Weasel	Muck	34	0-12	4	9.5
	Silty sand	300+	0-3	0	7.2
	Clean sand	140	0-6	1	8.3
	Asphalt pavement	---	---	0	6.0
Tournadozer	Silty clay, firm	300+	0-2	0	3.3
	Silty clay, soft	60	0-2	1.5	5.8
D7 tractor	Silty clay, firm	300+	0-2	0	7.0
	Silty clay, soft	60	0-2	2	10.6

A comparison of data given above with data in the preceding paragraph reveals that except in muck forces required to tow the weasel are greater than those required to tow the Airoll. In silty clay the Airoll has higher tow requirements than the Tournadozer on both firm and soft surfaces, and lower tow requirements than the D7 tractor on firm surfaces but higher requirements when the surface becomes soft enough to adhere to the tires.

Notes and Observations

53. During the Airoll tests, pertinent notes and observations were made of characteristics that influenced its mobility or possible military

utility. These observations are discussed in the following paragraphs.

Wheel-track combination

54. The most impressive characteristic of the Airoll is its ability to propel itself by either rolling- or stationary-wheel track action, giving it greater travel efficiency than that which can be attained with conventional track systems. Its ability to traverse soils that are soft to great depths exceeds that of the best current military vehicles.

Noise

55. When the Airoll was operating on steep clean sand slopes at Warren Dunes State Park, the sliding of the platform over the tires created a noise that could be heard one-half mile away on occasion. In the muck and mineral soil tests, water lubricated the contact area between the tires and platform, practically eliminating the noise.

Turning and maneuvering

56. The Airoll experienced some difficulty in making sharp turns on rough concrete surfaces or in soft muck. In turning, one track is braked while the other is powered. On concrete the frictional resistance between the concrete and rubber tires of the braked track was great enough to cause difficulty in executing sharp turns. In the soft muck, the powered track could not obtain sufficient traction to execute a sharp turn. On clean and silty sand, or firm surfaces with some loose soil on top, the Airoll could turn 180 degrees within the length of the vehicle. Turning on pavement or in soft soils could be improved by articulating the vehicle or by providing a "cross drive" power train that permits the transmission of power to each track in opposite directions.

Tires

57. Goodyear terra-tires with smooth tread were mounted on the Airoll during the test programs, and they appeared to be extremely durable under the severe treatment to which they were subjected, such as:

(a) occasionally the tires were overloaded when the Airoll passed over an obstacle or sharp-crested terrain when the entire weight of the Airoll was usually supported by four tires on each side; (b) tight turns caused extreme sidewall buckling; and (c) tree limbs and trunks were passed over without tire puncture, although on one occasion a valve stem was pulled out when hit by a tree limb.

Performance on slopes

58. Limited tests indicate that the performance of the Airoll on wet, fine-grained soil slopes is reduced by loss of frictional contact between the tires and the platform and that the vehicle can actually move backward while the drive sprockets are rotating in the forward direction (the tires roll backward). On firm slopes the inability of the tires to dig into the soil results in a decrease in friction between the bottom of the tires and the soil surface. In both cases the slope-climbing ability of the Airoll is less than that of conventional tracked vehicles with aggressive grousers. On the clean sand slopes that were softer than the others tested, the tires can dig in, and at 10- and 15-psi tire pressures the Airoll's slope-climbing ability exceeded that of conventional tracked vehicles with aggressive grousers. The factors that influenced the Airoll's track performance on slopes also influenced its towing performance.

PART V: CONCLUSIONS AND RECOMMENDATIONS

Conclusions

59. Based on test results reported herein, the following conclusions are offered:

- a. The experimental vehicle cone index is reasonably close to that computed for the Airoll.
- b. The Airoll can negotiate soft muck and wet, fine-grained soil areas that no known military vehicle of equal weight can negotiate.
- c. On clean, soft sand slopes such as those tested, the Airoll's slope-climbing ability at 10- and 15-psi tire pressures exceeds that of the weasel; however, on firm slopes or on slope surfaces that are conducive to slipperiness, the slope-climbing ability of the Airoll is less than that of the weasel.
- d. The Airoll's drawbar pull capabilities, based on drawbar pull-weight ratio, are less than those of conventional tracked vehicles for the soil conditions tested.
- e. The force required to tow the Airoll is comparable to that required for conventional tracked vehicles in soil and on the paved surfaces tested.
- f. The rolling-wheel track and stationary-wheel track features of the Airoll permit it to achieve greater travel efficiency on most soil conditions than conventional tracked vehicles.

Recommendations

60. It is recommended that:

- a. The Airoll be tested in soft snow.
- b. The Airoll be tested in organic soils such as muskeg.

Table 1
Results of Self-propelled Tests in Highly Organic Soils and Fine-grained Mineral Soils

Test No.	Immobilized	Immobilization on Pass No.	Pass No.	0- to 12-in. Depth			Dry Density lb/cu ft	Rut Depth in.	Remarks	
				Cone Index	Remolding Index	Rating Cone Index				
<u>Airoll Tests in Highly Organic Soils (Muck), Fort Custer, Michigan</u>										
1	No		0 10	26 7	0.58	15	296*	--	18	Completed 40 passes with ease. After deep ruts were formed, mixture of muck and water flowed into ruts
2	No		0 10 40	36 3"	0.77	28	408*	12.8*	14	Completed 40 passes with ease
3	No		0 10	30 23	0.50	15	550*	10.7*	12	Completed 30 passes with ease and it was apparent that 40 to 50 passes could have been completed
4	No		0 10 40	27 32	0.56	15	546*	10.7*	18	Completed 40 passes with ease
5	Yes	21	0 10 21	21 24	0.66	14	600+*	9.3*	36	Surface water covered test area; 10 passes completed with ease, then ruts began to deepen rapidly. Immobilized on 21st pass
<u>Airoll Tests in Fine-grained Soils (Silt), WES Bottomland Area</u>										
6	No		0 5 20 50	101 89 97 103	0.40	40	35.3	83.6	3 5 8	Completed 50 passes with ease. Tires were rolling forward with approximately 40% slip
7	No		0 5 20 50	59 86 101	0.43	25	40.3	78.0	3 6 9	Surface water 3 in. deep over test area; completed 50 passes with ease. Tires rotated in place
8	No		0 5 20 50	89 102 109 122	0.43	38	38.7	79.3	2 3 5	Surface water 1 in. deep over test area; completed 50 passes with ease. Tires rotated in place
9	No		0 5 20 50	67 93 110 113	0.48	32	43.0	75.9	3 5 7	Completed 50 passes with ease
10	No		0 50	71 110	0.42	30	41.1	77.2	7	Completed 50 passes with ease
<u>Airoll Tests in Fine-grained Soils (Sandy Clay), Port of Vicksburg Area</u>										
11	No (High slip)		0 5 20 40	56 66 40 7	0.41	23	35.9	82.6	5 10 26	Completed 50 passes. Bottom of frame dragging after 29 passes. Near 50 passes rutting was approximately 26 in. but due to high slips, the soft soil discharged at the rear of the tires filled the ruts to the original ground-surface level
12	No (High slip)		0 5 20 45	59 54 65 6	0.43	25	39.8	80.0	7 12 28	Completed 50 passes with high slip after 40 passes. Bottom of frame dragging after 30 passes. Due to high slips, the soft soil discharged at rear filled the ruts to the original ground-surface level
13	No		0 5 20	52 45 36	0.57	30	46.7	74.2	5 11	Completed 30 passes with ease. Test halted because of mechanical failure. Estimated that 50 passes could have been completed
14	Yes	11	0 11	19 12	0.62	12	41.6	76.7	36	Frame dragging on 9th pass. Extreme high slip on 10th pass. Immobilized on 11th pass; rut surface 6 in. above ground behind Airoll, bottom of frame 6 in. below ground surface
15	Yes (Estimated)	< 15	0 5	24 20	0.56	13	38.4	77.1	10	Frame dragging on 7th pass when test halted because of mechanical failure. Estimated that immobilization would have occurred in less than 15 passes
<u>Weasel Tests in Muck</u>										
16	No		0 40	44** 52	1.00†	44	---	--	2	Completed 40 passes with ease. Ruts filled with water
17	No		0 30	49 48	0.41	20	527	10.7	1	Completed 30 passes with ease. A dense root mat assisted in supporting the vehicle
18	No		0 30	39 43	0.52	20	444	12.3	-	Completed 30 passes with ease
19	No		0 40	33 49	1.00	33	998	4.8	5	Completed 40 passes with ease
20	No		0 40	26 20	0.62	16	---	--	6	Completed 40 passes with ease. Test lane was too soft for a man to walk over
21	Yes	20	0	21	0.62	13	---	--	-	Vehicle dragged on 9th pass. Could not stay in old ruts after 20 passes. Considered immobilized on 21st pass
22	No		0 40	30	0.50	15	527	10.6	6	Traveled 40 passes with ease. Root mat assisted in supporting vehicle
23	Yes	13	0 10	13 21	0.70	9	872	6.4	-	Vehicle dragged on 4th pass. Immobilized on 13th pass. Test lane was too soft to support foot traffic
<u>Weasel Test in Sandy Clay</u>										
24	Yes	17	0 17	30	0.49	15	---	--	13	Vehicle dragging on 8th pass. Immobilized going forward

* 0- to 12-in. depth.

** Cone index average for 3- to 9-in. depth for all weasel tests.

† Remolding index for 0- to 12-in. depth, assumed to be same for 3- to 9-in. depth.

Table 2
Results of Self-propelled Tests in Coarse-grained Soils (Clean Sand)

Test No.	Slope, %	Tire Pressure, psi	Immobilized	Before-Traffic Cone Index 0- to 6-in. Depth	Remarks
<u>Airroll Tests</u>					
1	61.5	15	Yes	25	
2	55.5	15	Yes	16	
3	51.0	15	No	39	Stationary-wheel track
4	50.0	15	No	24	Stationary-wheel track
5	38.5	15	No	29	Stationary-wheel track
6	30.5	15	No	33	Stationary-wheel track
7	28.5	15	No	43	Stationary-wheel track
8	20.5	15	No	58	Stationary-wheel track
9	19.5	15	No	65	Rolling-wheel track
10	18.5	15	No	53	Rolling-wheel track
11	16.5	15	No	52	Rolling-wheel track
12	62.5	10	Yes	44	
13	59.0	10	Yes	16	
14	57.5	10	No	47	Stationary-wheel track
15	56.5	10	Yes	23	
16	54.5	10	Yes	30	
17	53.0	10	Yes	21	
18	49.0	10	No	48	Stationary-wheel track
19	46.5	10	No	16	Stationary-wheel track
20	45.5	10	No	45	Stationary-wheel track
21	44.5	10	No	25	Stationary-wheel track
22	41.5	10	No	37	Stationary-wheel track
23	37.5	10	No	23	Stationary-wheel track
24	35.5	10	No	56	Stationary-wheel track
25	27.5	10	No	57	Stationary-wheel track
26	26.0	10	No	60	Stationary-wheel track
27	24.0	10	No	70	Stationary-wheel track
28	22.0	10	No	68	Stationary-wheel track
29	21.5	10	No	25	Stationary-wheel track
30	21.5	10	No	69	Rolling-wheel track
31	21.5	10	No	83	Rolling-wheel track
32	20.5	10	No	95	Rolling-wheel track
33	18.5	10	No	71	Rolling-wheel track
34	18.5	10	No	89	Rolling-wheel track
35	54.5	5	Yes	27	
36	49.0	5	Yes	24	
37	47.5	5	Yes	81	
38	47.5	5	Yes	24	
39	45.5	5	Yes	58	
40	33.5	5	No	53	Stationary-wheel track
41	31.5	5	No	75	Stationary-wheel track
42	31.5	5	No	83	Stationary-wheel track
43	29.5	5	No	82	Stationary-wheel track
44	27.5	5	No	59	Stationary-wheel track
45	27.5	5	No	80	Rolling-wheel track
46	27.5	5	No	73	Rolling-wheel track
47	25.0	5	No	67	Rolling-wheel track
48	24.0	5	No	100	Rolling-wheel track
49	24.0	5	No	47	Rolling-wheel track
50	13.0	5	No	50	Rolling-wheel track
<u>Weasel Tests</u>					
51	56.5		Yes	23	
52	51.0		Yes	39	
53	50.0		Yes	24	
54	47.5		No	81	
55	46.5		Yes	16	
56	45.5		No	58	
57	44.5		No	25	
58	38.5		No	29	
59	37.5		No	23	

Note: All tests conducted on moist dune sand; moisture contents, 1.5 to 3.0% of dry weight.

Table 3

Results of Towing Tests in Highly Organic Soils and Fine- and Coarse-grained Mineral Soils

Test No.	Tire Pressure psi	Drawbar Pull		Slip %	Before-Traffic Soil Data at Depths (in.) Specified					Remarks
		lb	% of Test Wt		Cone Index	Remolding Index	Rating Cone Index	Moisture Content, %	Dry Density lb/cu ft	
Drawbar Pull-Slip Tests										
Airoll Tests in Highly Organic Soils (Muck) (Wt 19,100 lb)										
1	8	4,500	23.6	100.0	62	0.70	43	330	18.1	Cone index = 35(0-6). Rut depth approximately 12 in. during pull. No vegetation
2	8	6,000	31.4	100.0	(6-12)*	(6-12)	(6-12)	(0-12)	(0-12)	
3	8	4,800	25.1	2.0						
4	8	4,200	22.0	0.0						
5	8	5,200	27.2	14.0						
6	8	2,000	10.5	-6.0						
7	8	750	3.9	-11.0						
Airoll Tests in Coarse-grained Soils (Silty Sand)										
8	8	10,000	52.4	100.0	300+	--	--	10.0**	85.0**	Some loose sand and dry grass on surface. Rut depth 1 in. or less
9	8	9,500	49.7	60.0	(0-2)			(0-6)	(0-6)	
10	8	9,500	49.7	32.0						
11	8	8,500	44.5	-4.0						
12	8	8,250	43.2	3.0						
13	8	8,000	41.9	2.0						
14	8	7,500	39.3	-6.0						
15	8	7,000	36.6	-42.0						
16	8	6,250	32.7	-58.0						
17	8	6,000	31.4	-50.0						
18	8	5,500	28.8	-85.0						
19	8	3,000	15.7	-98.0						
20	8	2,500	13.1	-96.0						
21	8	1,500	7.9	-89.0						
22	8	750	3.9	-100.0						
23	8	600	3.1	-100.0						
Airoll Tests in Coarse-grained Soils (Clean Sand)										
24	5	9,500	49.7	50.0	64	--	--	2.4	--	Moist sand. Level backshore area
25	5	7,500	39.3	28.0	(0-6)			(0-6)		
26	5	6,000	31.4	1.0						
27	5	5,000	26.2	-6.0						
28	5	4,750	24.9	-8.0						
29	5	4,500	23.6	-17.0						
30	5	4,250	22.3	-52.0						
31	5	4,000	20.9	-80.0						
32	5	9,500	49.7	100.0	63	--	--	--	--	
33	5	7,500	39.3	9.2	(0-6)					
34	5	6,250	32.7	-6.0						
35	5	2,500	13.1	-90.0						
36	5	750	3.9	-97.0						
Weasel Tests in Highly Organic Soils (Muck) (Wt 4200 lb)										
37	-	1,700	40.5	32.0	52	0.75	39	570	12.6	Water standing on surface. Rut depth increased with increased slip
38	-	1,500	35.7	25.0	(3-9)	(6-12)	(3-9)	(0-12)	(0-12)	
39	-	1,100	26.2	12.0						
40	-	900	21.4	11.0						
41	-	800	19.0	8.0						
42	-	500	11.9	6.0						
43	-	400	9.5	3.0						
44	-	250	6.0	2.0						
45	-	1,600	38.1	25.0						
46	-	1,600	38.1	21.0						
47	-	1,000	23.8	6.0						
48	-	900	21.4	10.0						
49	-	900	21.4	6.0						
50	-	400	9.5	0						
Weasel Tests in Coarse-grained Soils (Silty Sand)										
51	-	2,800	66.7	100.0	300+	--	--	---	--	Same area as Airoll tests 8-15
52	-	2,600	61.9	29.0	(0-2)					
53	-	2,200	52.4	14.0						
54	-	1,800	42.9	11.0						
55	-	1,700	40.5	7.0						
56	-	900	21.4	8.0						
57	-	1,600	38.1	14.0						
58	-	1,300	31.0	1.0						
59	-	700	16.7	4.0						
60	-	200	4.8	0						

(Continued)

* Numbers in parentheses are soil depth, i.e. (6- to 12-in. depth).

** Estimated.

Table 3 (Concluded)

Test No.	Pressure psi	Drawbar Pull		Slip %	Before-Traffic Soil Data at Depths (in.) Specified					Remarks
		lb	% of Test Wt		Cone Index	Remolding Index	Rating Cone Index	Moisture Content, %	Dry Density lb/cu ft	
<u>Maximum Drawbar Pull Tests in Fine-grained Soils (Silty Clay) (Firm, Dry, Bare Surface)</u>										
<u>Airoll Tests (Wt 19,100 lb)</u>										
61	8	14,500	75.9	100.0	300+(0-2)*	--	--	15.0**	--	Continuous 100% slip Initial 100% slip Usable drawbar pull
62	8	13,000	68.1	100.0						
63	8	11,250	58.9	75.0*						
<u>Tornadoizer Tests (Wt 30,100 lb)</u>										
64	25	21,000	69.8	100.0	300+(0-2)	--	--	15.0*	--	Continuous 100% slip Initial 100% slip Usable drawbar pull
65	25	21,000	69.8	100.0						
66	25	20,000	66.4	75.0*						
<u>DI Tractor Tests (Wt 32,000 lb)</u>										
67	--	--	--	100.0	300+(0-2)	--	--	15.0*	--	Continuous 100% slip Initial 100% slip Usable drawbar pull
68	--	30,000	93.8	100.0						
69	--	27,000	84.4	80.0*						
<u>Maximum Drawbar Pull Tests in Fine-grained Soils (Silty Clay) (Soft, Wet, Bare Surface)</u>										
<u>Airoll Tests</u>										
70	8	5,250	27.5	100.0	60(0-2); 300+(2-6)	--	--	33.5(0-2)	--	Continuous 100% slip Usable drawbar pull
71	8	4,750	24.9	75.0*						
<u>Tornadoizer Tests</u>										
72	25	6,500	21.9	100.0	60(0-2); 300+(2-6)	--	--	33.5(0-2)	--	Continuous 100% slip Usable drawbar pull
73	25	6,200	20.6	75.0*						
<u>DI Tractor Tests</u>										
74	--	14,500	45.3	100.0	60(0-2); 300+(2-6)	--	--	33.5(0-2)	--	Continuous 100% slip Usable drawbar pull
75	--	12,000	37.5	80.0*						

* Numbers in parentheses are soil depths, i.e. (0- to 2-in. depth).

** Estimated.

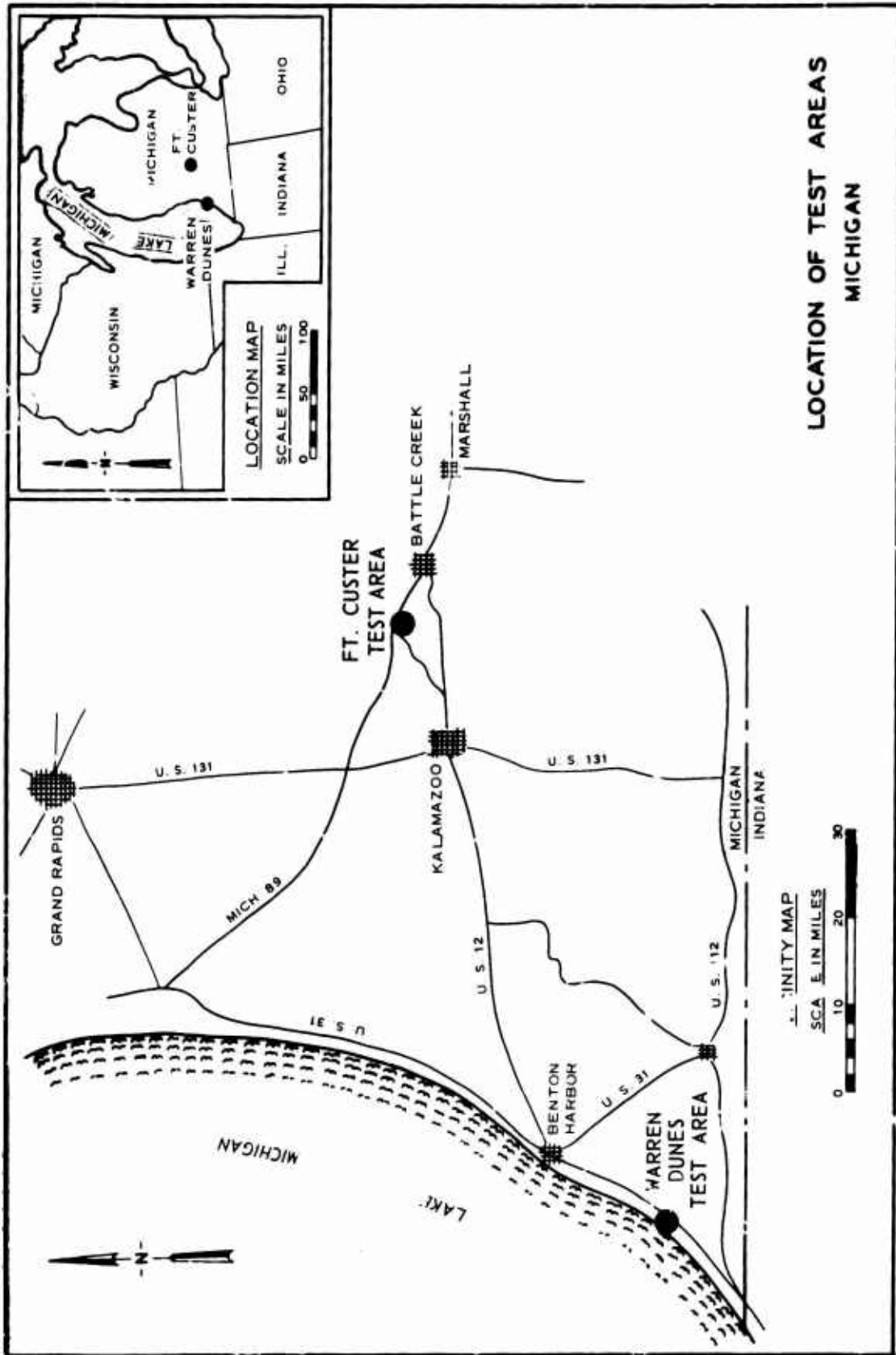

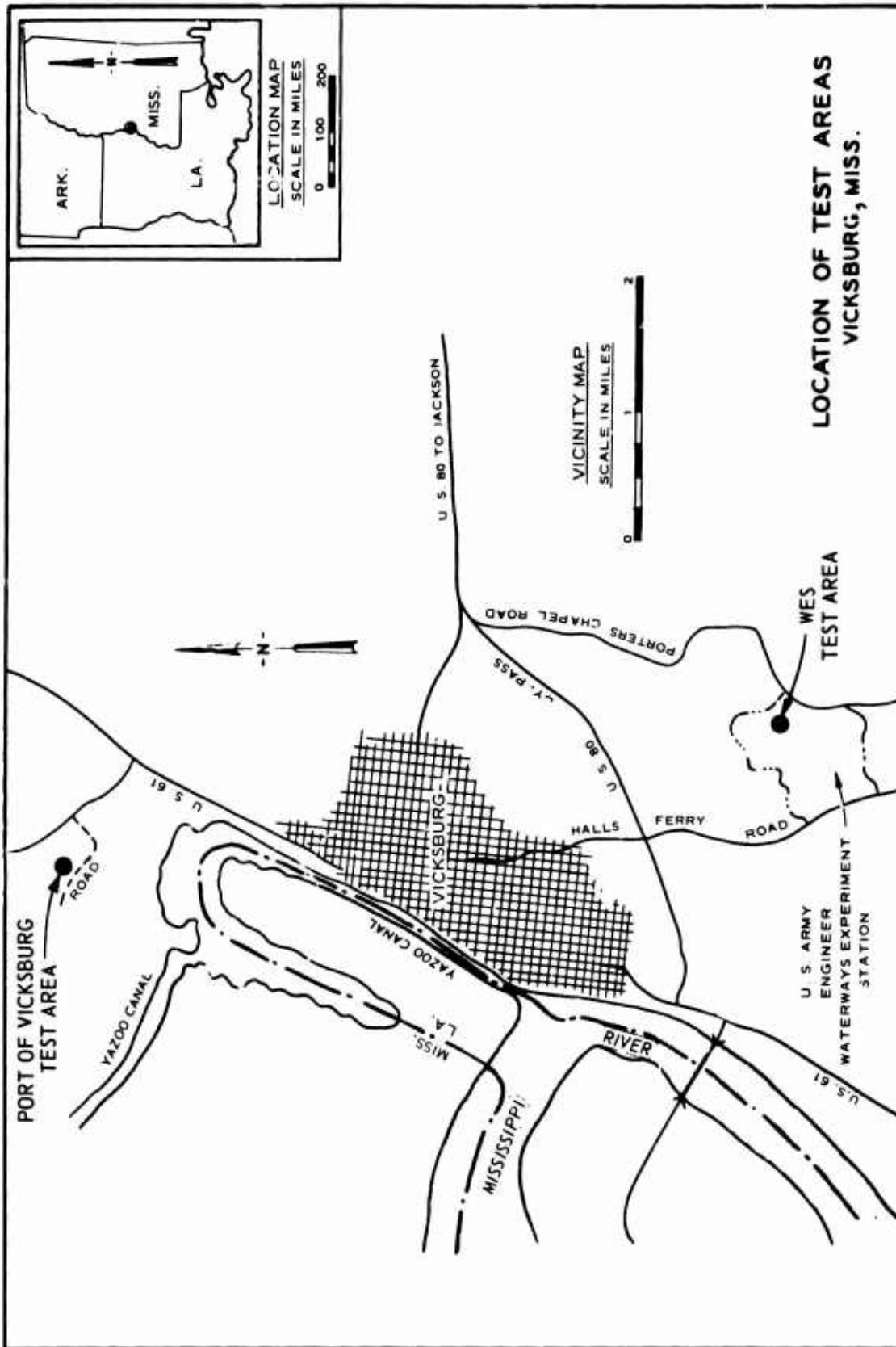
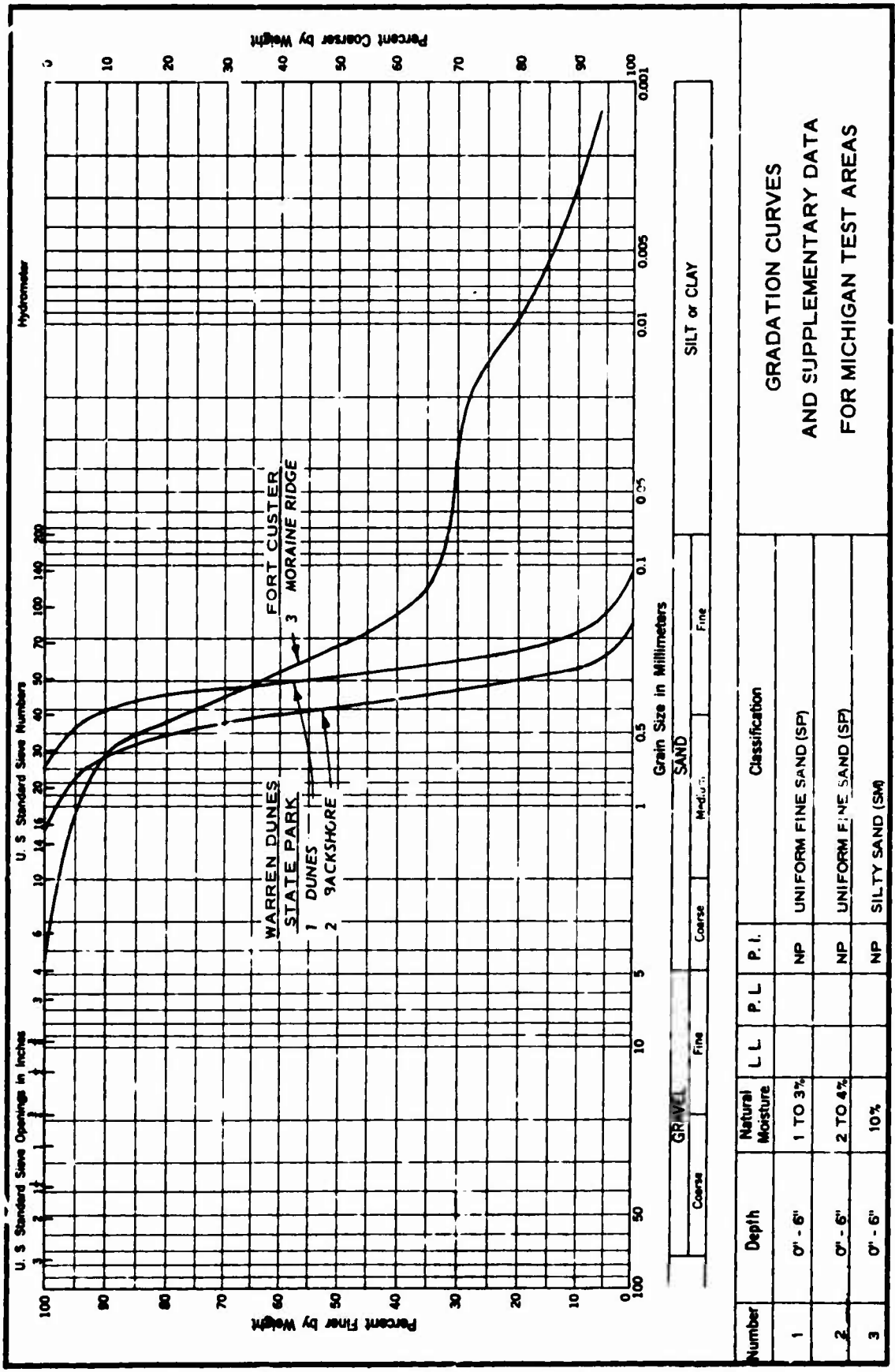
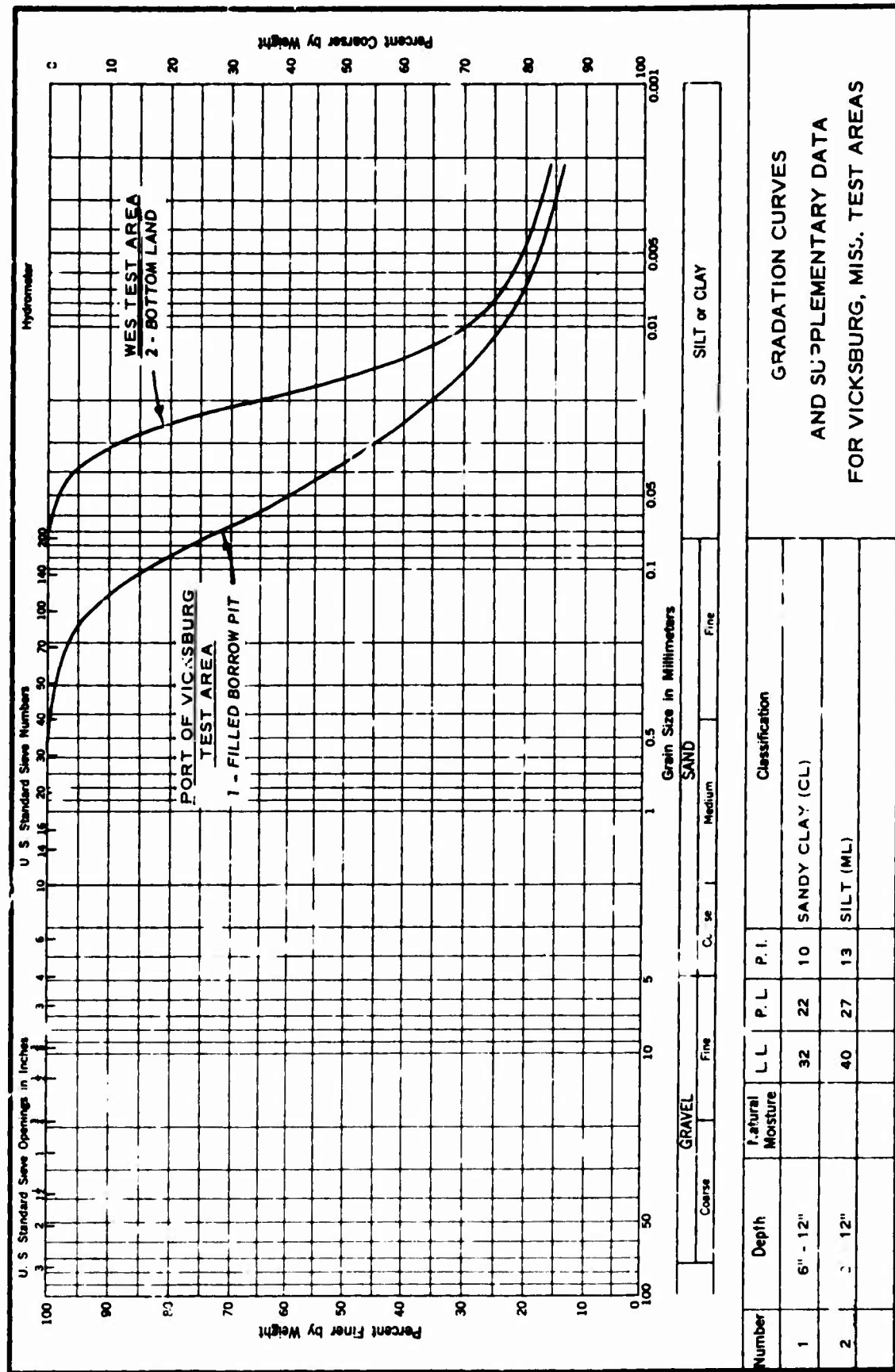

PLATE 2



GRADATION CURVES
AND SUPPLEMENTARY DATA
FOR MICHIGAN TEST AREAS



**GRADATION CURVES
AND SUPPLEMENTARY DATA
FOR VICKSBURG, MISS. TEST AREAS**

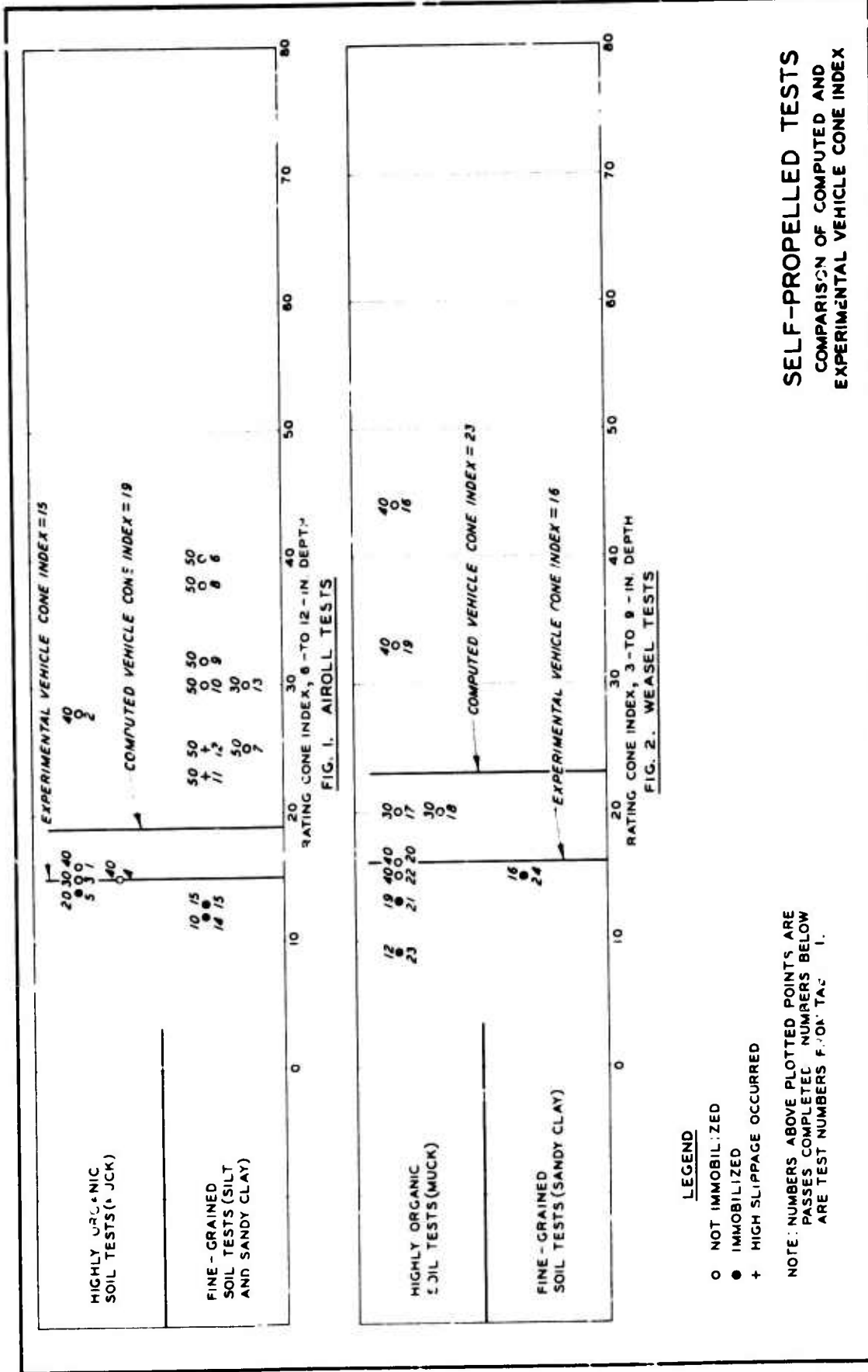

**SELF-PROPELLED TESTS
COMPARISON OF COMPUTED AND
EXPERIMENTAL VEHICLE CONE INDEX**

LEGEND

- NOT IMMOBILIZED
- IMMOBILIZED
- + HIGH SLIPPAGE OCCURRED

NOTE: NUMBERS ABOVE PLOTTED POINTS ARE PASSES COMPLETED NUMBERS BELOW ARE TEST NUMBERS FOR TAG "1."

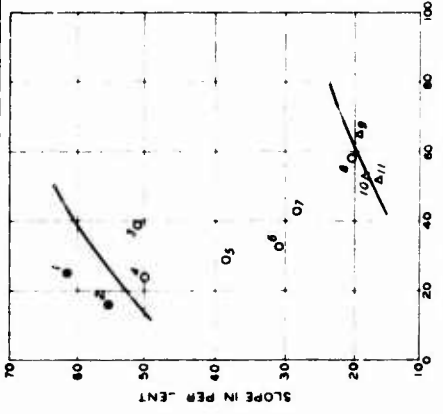

FIG. 1. 15-PSI TIRE PRESSURE

AIRROLL TESTS

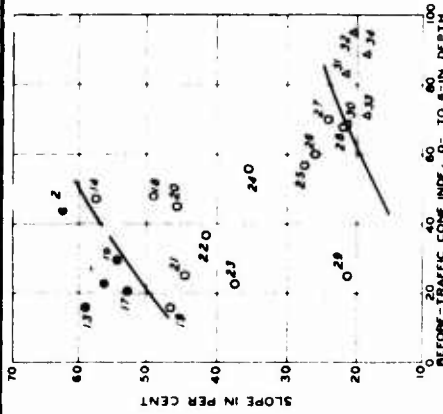

FIG. 2. 10-PSI TIRE PRESSURE

AIRROLL TESTS

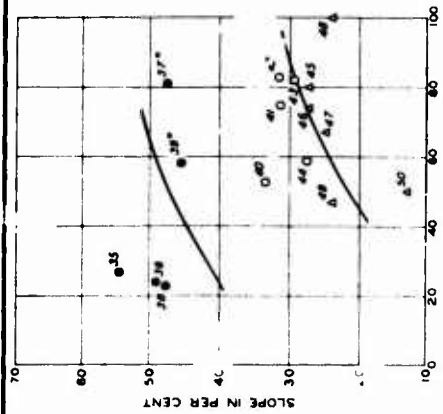

FIG. 3. 5-PSI TIRE PRESSURE

AIRROLL TESTS

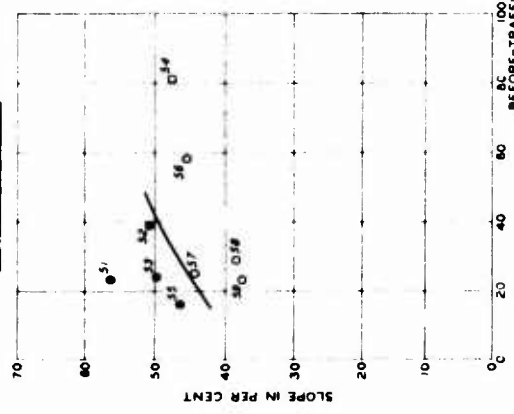

FIG. 4. M29C WEASEL TESTS

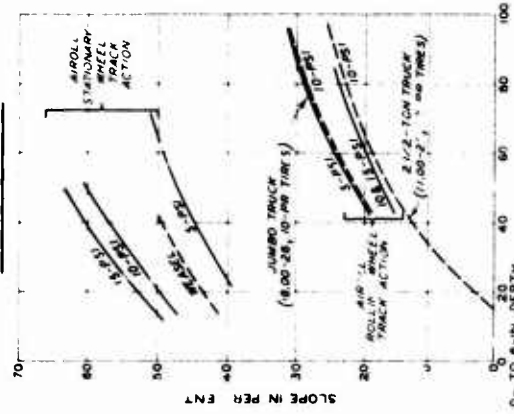

FIG. 5. COMPARISON OF AIRROLL PERFORMANCE WITH PERFORMANCE OF OTHER VEHICLES

AIRROLL PERFORMANCE WITH PERFORMANCE OF OTHER VEHICLES

LEGEND
 O DENOTES IMMOBILIZATION
 O DENOTES NONIMMOBILIZATION
 * SEE PARAGRAPH 37
 NUMBERS NEAR PLOTTED POINTS ARE TEST NUMBERS FROM TABLE 2
 FOR FIG. 5
 PERFORMANCE OF AIRROLL AT TIRE PRESSURES NOTED
 PERFORMANCE OF OTHER VEHICLES - AS NOTED

SELF-PROPELLED TESTS
 SLOPE - CCNF INDEX RELATIONS
 CLEAN SAND

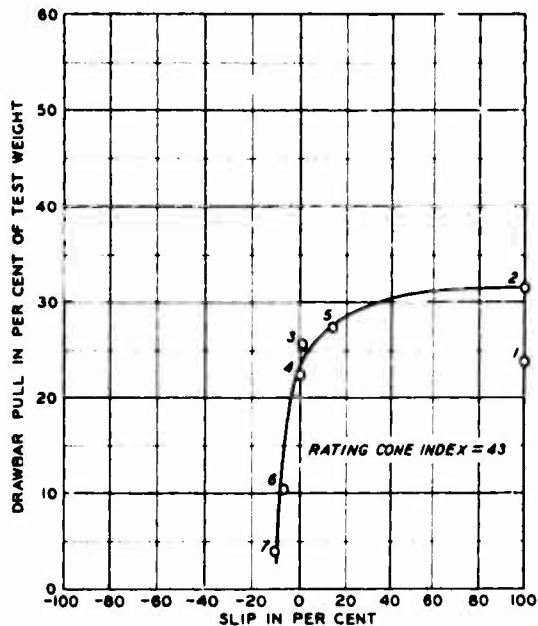

FIG. 1. MUCK TESTS

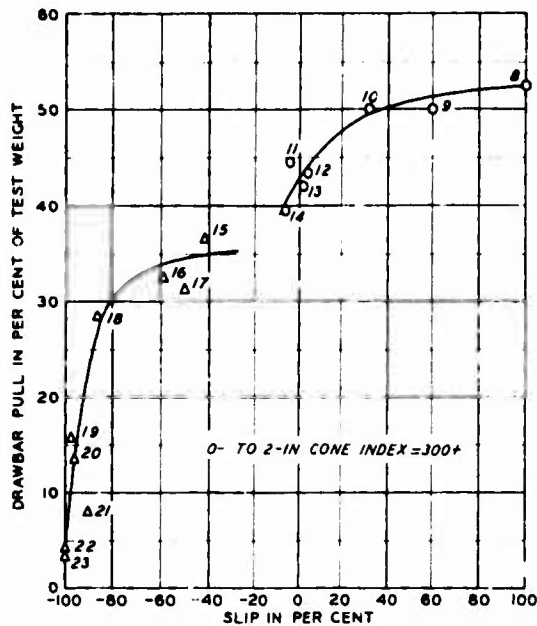

FIG. 2. SILTY SAND TESTS

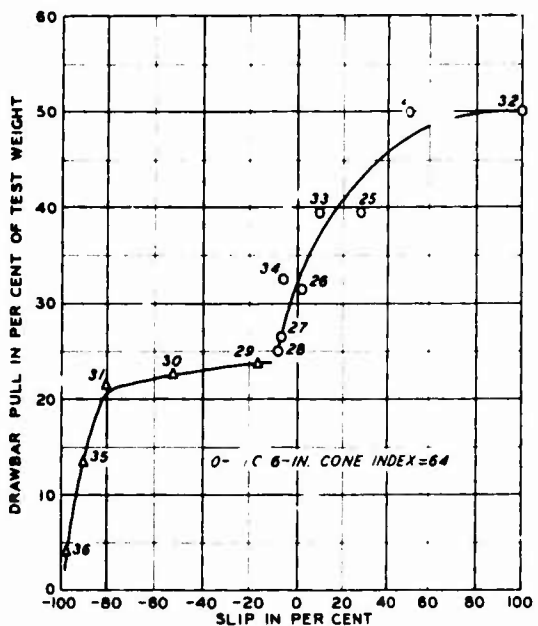

FIG. 3. CLEAN SAND TESTS

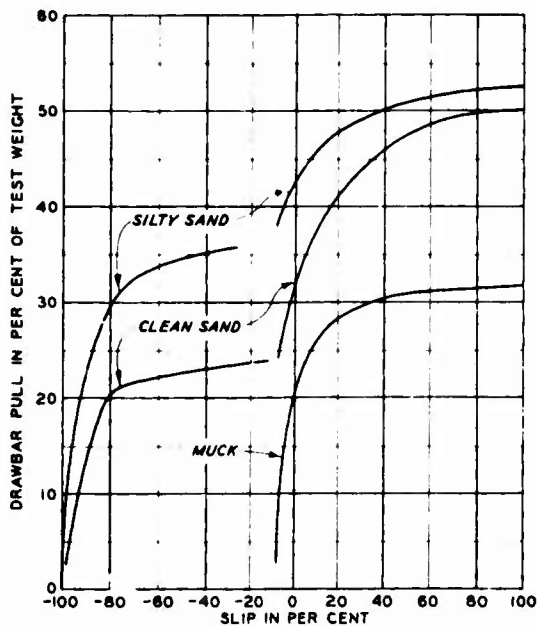

FIG. 4. SUMMARY OF CURVES

LEGEND

- O DENOTES STATIONARY-WHEEL TRACK ACTION
- Δ DENOTES ROLLING-WHEEL TRACK ACTION

NOTE: NUMBERS NEAR PLOTTED POINTS ARE TEST NUMBERS FROM TABLE 3.

TOWING TESTS
DRAWBAR PULL-SLIP CURVES
AIROLL

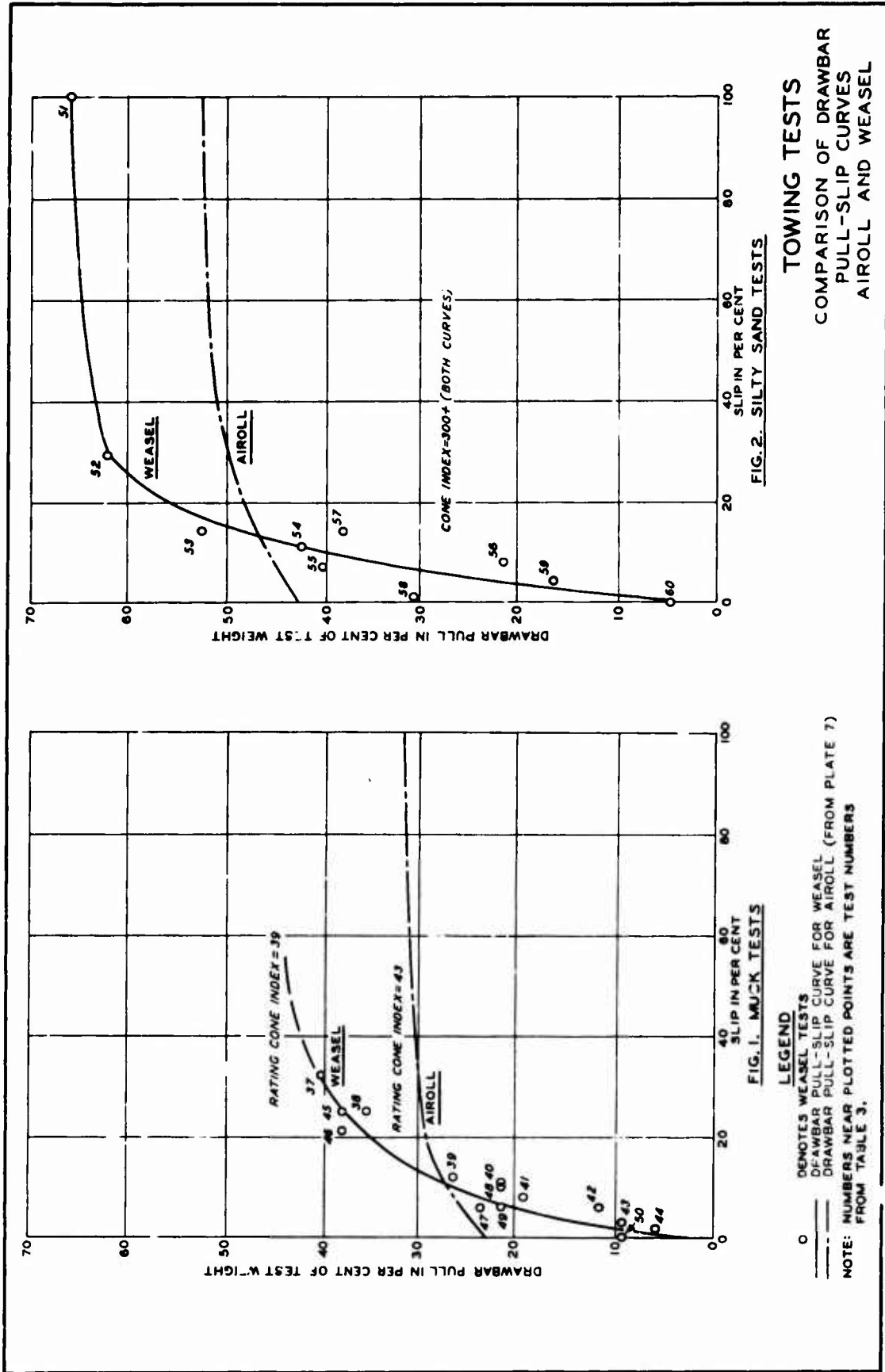

APPENDIX A: AIROLL SUSPENSION SYSTEM

1. The Airoll suspension system, as originally conceived by the Ingersoll Kalamazoo Division of Borg-Warner Corporation, is an entirely new concept of locomotion combining the free-rolling resilience of a pneumatic tire and the maximum mobility of a laterally rigid track-laying vehicle.

2. Fig. A1 shows a self-propelled model constructed to demonstrate



Fig. A1. Airoll model

the Airoll principle. It can be seen that the drive system is composed of a series of free-rolling, low-pressure pneumatic tires, mounted on an endless chain rotating about a driving sprocket and a return idler or sprocket assembly. The suspended weight is distributed over a series of tires that are compressed between the hull bottom and the ground. The large-footprint tires readily absorb bumps and function as springs. Therefore, all conventional suspension components are eliminated for maximum simplicity. In operation, the chain sets the tire on the ground in front of the hull, which then rolls over it, until the chain picks up the tire from the ground at the rear, to return it to the front, which completes the cycle.

3. The Airoll can operate by either or a combination of two entirely different modes of propulsion. In the first, the tires roll and there is

relative motion between the chain and the ground. In the second, the chain remains fixed relative to the ground as in conventional track-laying vehicles. The change-over from one mode to the other is entirely automatic and occurs as demanded by terrain conditions. There are intermediate stages which are a combination of the two modes. However, for clarification, the following discussion is limited to an analysis of the mechanics which apply to each of the systems.

4. Assume for the purpose of this analysis that we have a model of each type, each weighing 2000 lb. Assume further that the coefficient of friction between all rolling surfaces is 0.1, and that the steady-state rolling resistance of each model is 200 lb; then: "If a body is at rest, or maintains a uniform straight-line velocity, all the external forces acting on the body must balance." From this fundamental law of motion and the assumptions just stated, we will develop the theories of propulsion for Case 1 Airoll Mode and Case 2 Track-Laying Mode.

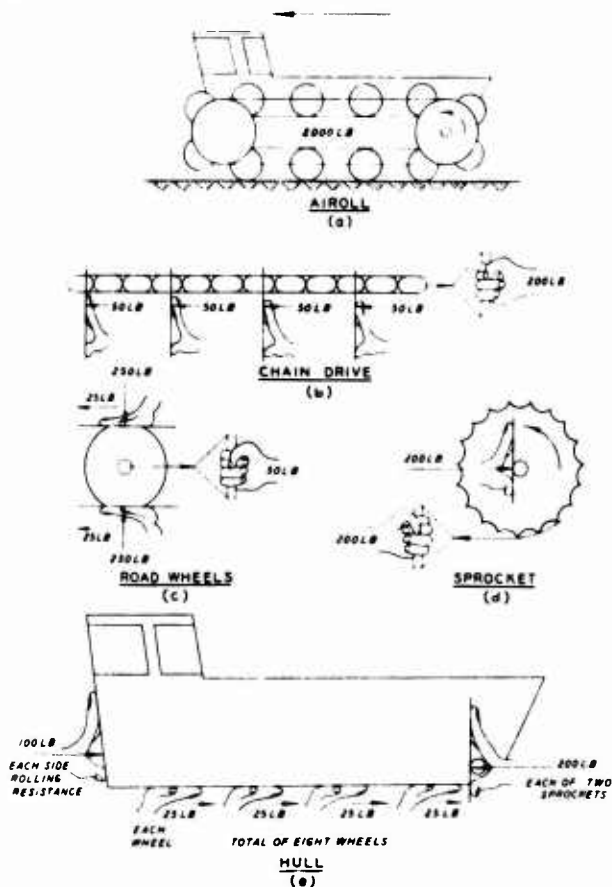

Fig. A2. Airoll mode

5. Fig. A2(a) is an Airoll having four (4) road wheels, or wheels in contact with the ground, on each side, and moving toward the left. The total weight is uniformly distributed, i.e. $2000/8 = 250$ lb per wheel. The wheels are free to turn on their axles, and the axles are mounted at each end in a chain which is driven by the sprocket. The load is transmitted directly from the body of the Airoll through the tire to the ground, and the axle does not contribute to support.

6. Fig. A2(c) shows one of the wheels as a free body. Equal frictional forces act at the points of contact with the

Airoll body and the ground. The chain tension must balance the frictional forces as shown. In fig. A2(b) we see the chain as a free body. The total chain tension is the sum of all the frictional forces or 200 lb. Fig. A2(d) is a free-body diagram of the sprocket showing the chain tension of 200 lb acting to the left and the bearing reaction, equal in magnitude and opposite in direction.

7. Fig. A2(e) shows the Airoll body and the forces which act on it. The sprocket bearing reaction on the hull is 200 lb acting to the left. Acting to the right are two forces: the rolling resistance of 100 lb and the frictional forces at each wheel contact point, which all together total 200 lb. Thus, the driving force balances the rolling resistance.

8. Fig. A3(a) is a track-laying vehicle moving toward the left and having four (4) road wheels on each side. The total weight is uniformly distributed as before. Fig. A3(b) is the track on the ground showing the friction forces which result from the wheel loads. With the sprocket rotating as shown in fig. A3(a), the track tension is the sum of the frictional forces, or 100 lb. Fig. A3(c) is a free-body diagram of the drive sprocket. The forces on the sprocket are the track tension acting to the left and the bearing reaction acting to the right. The bearing reaction on the hull is shown in fig. A3(d). This 100-lb force on the hull serves to overcome the rolling resistance and keep the vehicle moving at constant speed. Since there are two sprockets, the total driving force is 200 lb. Thus, the forces are again balanced.

9. There are basic differences between the two modes of propulsion which should be

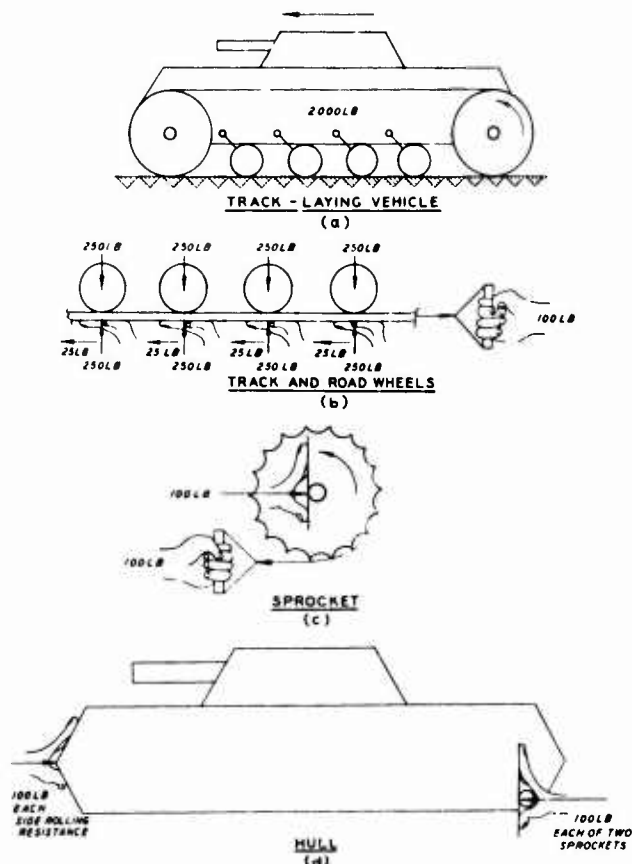

Fig. A3. Track-laying mode

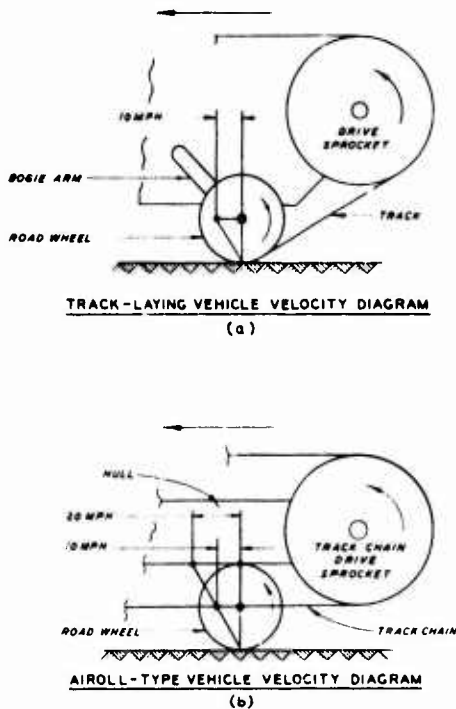

Fig. A4. Velocity diagrams

noted. For instance, there are frictional forces acting on the body in the Airoll version but none on the tracked vehicle. The result is a 200-lb track tension in the Airoll compared to 100 lb for the tracked vehicle. Although the track tension is double for the Airoll, the track speed is one-half that of a conventional tracked vehicle. By referring to the velocity diagrams in fig. A4(a) and A4(b) it can be seen that for a given vehicle speed of 30 mph, the track speed or pitch line speed of the sprocket will be 15 mph for the Airoll and 30 mph for the tracked vehicle. Thus, the propulsion hp is the same for each type. For example, assume that a sprocket speed and torque of 280 rpm and 200 lb-ft will propel a tracked vehicle at 20 mph. The $hp = 200 \times 280 / 5250 = 10.7$. The Airoll would require double torque and one-half sprocket speed or 400 lb-ft and 140 rpm and the hp would again be $400 \times 140 / 5250 = 10.7$. The reduced speed is considered very desirable because it ensures high speeds over improved roads and decreases track and sprocket wear which is always critical in a high-speed tracked vehicle.

10. Operation of the Airoll as a track-laying machine is described as follows. When the rolling resistance exceeds the frictional resistance between the tire and the hull, or body, the hull will slide over the top of the tire which remains stationary with the ground. This occurs with no change in required hp, but the speed of the Airoll is reduced by one-half to compensate for the different mode. Sliding over the top of the tire occurs in relatively firm terrain when the coefficient of friction between the tire and the ground is greater than that between the hull and the tire. In soft terrain the tire embeds in a pocket and acts as a very large grouser. In this case the tire usually rotates in the pocket as the hull rolls over it but with no linear motion. The shear strength of the soil between the large pockets results in exceptional drawbar pull. In fluid mud

the tires act as paddles and propel the vehicle by inertia of the mass being moved. Propulsion in water occurs in the same manner, and thus the Airoll is truly amphibious. It should be noted here that displacement is very important in this concept rather than just flotation which is usually the important factor in conventional tracks. Displacement is important because the system can be designed to float through fluid soils, or water, on tire displacement. In other words, if ground tire displacement of the medium equals gross Airoll weight, the Airoll will propel through any type of fluid terrain.

11. A summary of the many advantages offered by the Airoll system are enumerated below.

- a. Mobility under adverse conditions will exceed that of any known conventional vehicle. This is attributed to the fact that the suspension automatically shifts from a rolling-tire to a track-laying principle. When the shift occurs, the large tires embed themselves in the soft terrain and act as very large grousers or cleats to produce outstanding tractive effort. This maximum tractive effort, together with the large displacement provided by the tires, will virtually float the vehicle through fluid swamps usually considered impassable.
- b. Operation over improved roads is accomplished with no damage to the surface of the roads; on the other hand, conventional tracked vehicles usually scar or dig up the surface during a change in direction. Almost any reasonable speed can be provided because the speed of the Airoll hull is twice the track speed. As an example, a conventional track-laying vehicle with a track or sprocket pitch line speed of 30 mph would travel at 30 m.p.h. The same vehicle, with the same sprocket speed but equipped with an Airoll suspension, would travel at a speed of 60 mph.
- c. The power train is simplified because regardless of the number of ground contact tires, they are all driven from two power outlets, one on each side of the vehicle. This is in contrast to a multi-wheeled, axle-driven vehicle which must have a power outlet for each of the wheels.
- d. Finally, the elimination of suspension components such as springs, trailing arms, shock absorbers, etc., results in a greatly simplified installation.

**APPENDIX B: DETERMINATION OF VEHICLE CONE INDEXES
FOR AIROLL OPERATION ON FINE-GRAINED SOILS**

1. The vehicle cone index is the minimum one index that will permit the vehicle to complete 50 passes. It is based on the mobility index of the vehicle. Computation of the mobility indexes and vehicle cone indexes of the Airoll is described in detail in the following paragraphs.

Mobility Index

2. The mobility index is a dimensionless number obtained by applying certain vehicle characteristics to formulas given in the following paragraphs. Since the Airoll can operate by either rolling-wheel or stationary-wheel track action, its wheeled and tracked mobility indexes have been computed. Because of certain unconventional characteristics of the Airoll, the formulas cannot be applied unless certain assumptions are made; these assumptions are mentioned as necessary.

Formula for self-propelled wheeled vehicles

3. The Airoll is assumed to be operating as a conventional wheeled vehicle, and all tires in contact with the ground are assumed to be powered. The basic formula is as follows:

$$\text{Mo-} \left[\frac{\text{contact pressure} \times \text{weight factor}}{\text{tire factor} \times \text{grouser factor}} + \frac{\text{wheel load} \times \text{clearance factor}}{\text{factor}} \right] \times \text{engine factor} \times \text{mission factor} + 20$$

Vehicle Factors Value

$$\text{Contact pressure factor} = \frac{\text{gross weight, lb}}{\text{tire width, in.} \times \text{rim diam, in.} \times \text{No. of tires}} = \frac{19,000}{24 \times 6 \times 14} = 9.42^*$$

(Continued)

* In the above expression it was assumed that 14 tires were in contact with the ground. At times only 12 tires may be in contact with the ground.

B2

Vehicle Factors	Value
Weight factor: 15,000 to 35,000 lb	= 1.00
Tire factor = $\frac{1.25 \times \text{tire width, in.}}{100} = \frac{1.25 \times 24}{100}$	= 0.30
Grouser factor: without chains	= 1.00
Wheel load = $\frac{\text{gross wt, kip}}{\text{No. of wheels}} = \frac{19}{14}$	= 1.36
Clearance factor = $\frac{\text{clearance in in.}}{10} = \frac{26}{10}$	= 2.60
Engine factor: 10 or greater hp per ton of vehicle wt.	
$\left(\frac{185}{10} \text{ or } \frac{18.5 \text{ hp}}{\text{ton}}\right)$	= 1.00
Transmission factor: hvdraulic	= 1.00
MI = $0.6 \left[\left(\frac{9.42 \times 1.00}{0.30 \times 1.00} + 1.36 - 2.60 \right) \times 1.00 \times 1.00 \right] \cdot 20$	= 38.1

Formula for self-propelled tracked vehicles

4. In determining the mobility index of the Air-ll as a tracked vehicle it was assumed that the track length is the distance between centers of idler and drive sprockets and that the track width is the nominal width of the tires. It was also assumed that the tires act as grousers and bogies, and that the area of one track shoe is the area of one tire determined from the tire length and width as given in the tire size. The basic formula is as follows:

$$\text{Mobility index} = \left(\frac{\text{contact pressure factor} \times \text{weight factor}}{\text{track factor} \times \text{grouser factor}} + \text{bogie factor} - \text{clearance factor} \right) \times \text{engine factor} \times \text{transmission factor}$$

Vehicle Factors	Value
Contact pressure factor = $\frac{\text{gross wt in lb}}{\text{area of tracks, sq n.}} = \frac{19,000}{213 \times 24 \times 2}$	= 1.86
Weight factor: 50,000 lb	= 1.00
Track factor = $\frac{\text{track width, in.}}{100} = \frac{24}{100}$	= 0.24
Grouser factor: >1.5 in.	= 1.10
Bogie factor: $\frac{\text{gross wt (lb) divided by 10}}{(\text{total No. of bogies in contact with ground}) \times (\text{area of 1 track shoe, in.})}$	= $\frac{19,000 \div 10}{14 \times 24 \times 24} = 0.24$
Clearance factor = $\frac{\text{clearance, in.}}{10} = \frac{26}{10}$	= 2.60
Engine factor: 10 or greater hp per ton of vehicle wt	= $\left(\frac{185}{10} \text{ or } \frac{18.5 \text{ hp}}{\text{ton}}\right) = 1.00$
Transmission factor: hydraulic	= 1.00
MI = $\left(\frac{1.86 \times 1.00}{0.24 \times 1.10} + 0.24 - 2.60\right) \times 1.00 \times 1.00$	= 4.7

Vehicle Cone Index

5. The VCI is obtained from a curve of MI versus VCI (fig. B1). It can be seen that the Airoll has a VCI of 13 assuming wheeled-vehicle status and 19 assuming tracked-vehicle status.

Fig. B1. Mobility index versus vehicle cone index for the Airoll

