

AD/A-006 559

ERECTING GAS STORAGE FACILITIES AND
OIL CENTERS

T. T. Stulov, et al

Foreign Technology Division
Wright-Patterson Air Force Base, Ohio

21 January 1975

DISTRIBUTED BY:

NTIS

National Technical Information Service
U. S. DEPARTMENT OF COMMERCE

Unclassified
Security Classification

AD/A-006559

DOCUMENT CONTROL DATA - R & D

(Security classification of title, body of abstract and indexing annotation must be entered when the overall report is classified)

1. ORIGINATING ACTIVITY (Corporate author) Foreign Technology Division Air Force Systems Command U. S. Air Force		2a. REPORT SECURITY CLASSIFICATION Unclassified	
2. REPORT TITLE ERECTING GAS STORAGE FACILITIES AND OIL CENTERS		2b. GROUP	
3. DESCRIPTIVE NOTES (Type of report and inclusive dates) Translation			
4. AUTHOR(S) (First name, middle initial, last name) T. T. Stulov, B. V. Popovskiy, O. M. Ivanov, et.al.			
6. REPORT DATE 1973	7a. TOTAL NO. OF PAGES 517	7b. NO. OF REFS 17	
8a. CONTRACT OR GRANT NO.	8b. ORIGINATOR'S REPORT NUMBER(S) FTD-HC-23-1722-74		
b. PROJECT NO.	8c. OTHER REPORT NO(S) (Any other numbers that may be assigned this report)		
c.			
d. T74-04-05			
10. DISTRIBUTION STATEMENT Approved for public release; distribution unlimited.			
11. SUPPLEMENTARY NOTES		12. SPONSORING MILITARY ACTIVITY Foreign Technology Division Wright-Patterson AFB, Ohio	
13. ABSTRACT 11,05			

Reproduced by
NATIONAL TECHNICAL
INFORMATION SERVICE
U S Department of Commerce
Springfield VA 22151

DD FORM 1473
1 NOV 55

UNCLASSIFIED
PRICES SUBJECT TO CHANGE
Security Classification

EDITED TRANSLATION

FTD-HC-23-1722-74

21 January 1975

ERECTING GAS STORAGE FACILITIES AND OIL CENTERS

CSP73334411

By: T. T. Stulov, B. V. Popovskiy, O. M. Ivanov,
et.al.

English pages: 512

Source: Sooruzheniye Gazokhranilishch I Neftebaz,
1973, pp. 1-368

Country of Origin: USSR
Translated under: Linguistics Systems Inc.,
F33657-72-D-0854

Requester: FTD/PDTA
Approved for public release;
distribution unlimited.

THIS TRANSLATION IS A RENDITION OF THE ORIGINAL FOREIGN TEXT WITHOUT ANY ANALYTICAL OR EDITORIAL COMMENT. STATEMENTS OR THEORIES ADVOCATED OR IMPLIED ARE THOSE OF THE SOURCE AND DO NOT NECESSARILY REFLECT THE POSITION OR OPINION OF THE FOREIGN TECHNOLOGY DIVISION.

PREPARED BY:

TRANSLATION DIVISION
FOREIGN TECHNOLOGY DIVISION
WP-AFB, OHIO.

RUSSIAN AND ENGLISH TRIGONOMETRIC FUNCTIONS

Russian	English
sin	sin
cos	cos
tg	tan
ctg	cot
sec	sec
cosec	csc
sh	sinh
ch	cosh
th	tanh
cth	coth
sch	sech
csch	csch
arc sin	\sin^{-1}
arc cos	\cos^{-1}
arc tg	\tan^{-1}
arc ctg	\cot^{-1}
arc sec	\sec^{-1}
arc cosec	\csc^{-1}
arc sh	\sinh^{-1}
arc ch	\cosh^{-1}
arc th	\tanh^{-1}
arc cth	\coth^{-1}
arc sch	sech^{-1}
arc csch	csch^{-1}
—	
rot	curl
lg	log

GRAPHICS DISCLAIMER

All figures, graphics, tables, equations, etc.
merged into this translation were extracted
from the best quality copy available.

U. S. BOARD ON GEOGRAPHIC NAMES TRANSLITERATION SYSTEM

Block	Italic	Transliteration	Block	Italic	Transliteration
А а	<i>А а</i>	A, a	Р р	<i>Р р</i>	R, r
Б б	<i>Б б</i>	B, b	С с	<i>С с</i>	S, s
В в	<i>В в</i>	V, v	Т т	<i>Т т</i>	T, t
Г г	<i>Г г</i>	G, g	У у	<i>У у</i>	U, u
Д д	<i>Д д</i>	D, d	Ф ф	<i>Ф ф</i>	F, f
Е е	<i>Е е</i>	Ye, ye; E, e*	Х х	<i>Х х</i>	Kh, kh
Ж ж	<i>Ж ж</i>	Zh, zh	Ц ц	<i>Ц ц</i>	Ts, ts
З э	<i>З э</i>	Z, z	Ч ч	<i>Ч ч</i>	Ch, ch
И и	<i>И и</i>	I, i	Ш ш	<i>Ш ш</i>	Sh, sh
Й й	<i>Й й</i>	Y, y	Щ щ	<i>Щ щ</i>	Shch, shch
Н н	<i>К к</i>	K, k	Ъ ъ	<i>Ъ ъ</i>	"
Л л	<i>Л л</i>	L, l	Ы ы	<i>Ы ы</i>	Y, y
М м	<i>М м</i>	M, m	Ь ь	<i>Ь ь</i>	'
Н н	<i>Н н</i>	N, n	Э э	<i>Э э</i>	E, e
О о	<i>О о</i>	O, o	Ю ю	<i>Ю ю</i>	Yu, yu
П п	<i>П п</i>	P, p	Я я	<i>Я я</i>	Ya, ya

*ye initially, after vowels, and after ъ, ь; e elsewhere.
 When written as *ë* in Russian, transliterate as *yë* or *ë*.
 The use of diacritical marks is preferred, but such marks may be omitted when expediency dictates.

GREEK ALPHABET

Alpha	Α α	α	Nu	Ν ν	ν
Beta	Β β	β	Xi	Ξ ξ	ξ
Gamma	Γ γ	γ	Omicron	Ο ο	ο
Delta	Δ δ	δ	Pi	Π π	π
Epsilon	Ε ε	ε	Rho	Ρ ρ	ρ
Zeta	Ζ ζ	ζ	Sigma	Σ σ	ς
Eta	Η η	η	Tau	Τ τ	τ
Theta	Θ θ	θ	Upsilon	Υ υ	υ
Iota	Ι ι	ι	Phi	Φ φ	φ
Kappa	Κ κ	κ	Chi	Χ χ	χ
Lambda	Λ λ	λ	Psi	Ψ ψ	ψ
Mu	Μ μ	μ	Omega	Ω ω	ω

ERECTING GAS STORAGE FACILITIES AND OIL CENTERS

Published by the USSR Ministry of Higher and Intermediate Specialized Education as a text book for students in higher educational institutions who are studying the special subject, "Erecting Gas and Oil Pipelines, Gas Storage Facilities, and Oil Centers".

"NEDRA" Publishing House

Moscow 1973

Erecting Gas Storage Facilities and Oil Centers. Moscow "Nedra", 1973, 368 p. authors T. T. Stulov, B. V. Popovskiy, O. M. Ivanstov, M. K. Safaryan, V. A. Afanas'ev.

This text book sets forth basic information about oil centers and modern methods of constructing steel and concrete tanks for storing petroleum and petroleum products. Problems in designing steel and concrete oil tank members for strength and durability are also discussed.

Information is given about the design and construction of gas storage tanks. A separate chapter is devoted to the latest methods of building storage tanks. A detailed description is given on erecting reenforced concrete oil storage tanks as well as underground gas storage tanks.

The final chapter covers the machinery which must be used with steel or reenforced concrete storage tanks.

The text book is intended for students attending higher educational institutions which are concerned with petroleum.

There are 25 tables, 211 illustrations and a bibliography with 17 references.

Foreword

Since the production and refining of petroleum and gas within the USSR has increased each year, oil tank farms must be expanded and a larger number of gas storage facilities must be constructed. Oil tank farm expansion comes about either by building new and more efficient oil storage tanks, or by increasing existing tank capacity.

Widespread use of industrial building methods has permitted a significant increase in the tempo of erecting more tank capacity. Thanks to the use of prefabricated parts in reinforced concrete storage tanks, large oil tank farms have been built up which are efficient and long-lasting facilities. Loss of petroleum and petroleum products has been curtailed sharply through the use of pontoons and breather roofs.

Industrial building methods have reduced the cost of constructing such complex facilities as wet and dry sealed, low pressure gas containers. Thanks to new materials, it is now possible to erect buildings of completely different designs, such as, for example, dry sealed gas storage tanks with variable cross-sections. The widely adopted practice of automatic welding helped the rapid and reliable construction of the important spherical type storage containers.

The ever growing production and consumption of natural gas has forced construction of a number of large scale underground gas storage facilities.

Storage tank construction was started in our country by the outstanding engineer (later academician) V. G. Shukhov. The first riveted, steel storage tank was built to his design in 1878. Subsequently, oil centers were built in a number of different regions to supply consumers with petroleum products.

Steel storage tank construction was perfected during the Soviet era, and capacity grew. The first standard on riveted storage tanks with capacities up to 10,500 m³ (OST 5125-32) was approved in 1932. Starting in 1937, electric welding was used to build storage tanks. After 1944 all storage tanks up to 4600 m³ were welded and in 1951 construction of riveted storage tanks was discontinued entirely.

During the period from 1944 to 1949 the Electro-Welding Institute of the Academy of Science of the Ukrainian Soviet Socialist Republic, at the prompting of G. V. Rayevskiy, developed and put into use an industrial technique of building storage tanks from rolled stock as received from the factory. This method is not only widely used today in building gas and oil storage tanks but is also used to line hydroelectric station tunnels, smokestacks, etc. Storage tank capacity built using this method totalled 30,000 m³.

Reinforced concrete storage tanks are also being built in this country. The first reinforced concrete storage tanks were built in the Baku region in 1912. Deep cylindrical, reinforced concrete, storage tanks with capacities up to 7000 m³ were designed and built over a thirty year span. Cylindrical, reinforced concrete storage tanks with capacities of 160, 250 and 500 m³ were built in 1935. All these tanks were monolithic. Improvements within the construction industry made it possible to shift over to prefabricated, reinforced concrete, tanks. The maximum capacity of these types of storage units already totals 30,000 m³.

A wet seal type gas storage tank with a capacity of 100,000 m³ was built at Dnepropetrovsk in 1933. First gas storage tank

designs were riveted. Subsequently, as has already been noted, electric welding and industrial type assembly techniques were also introduced into this area.

This book examines the problems in erecting oil and gas storage facilities using current industrial techniques. Chapters 1, 9, 10, 11 and 12 were written by T. T. Stulov, chapters 2, 3 and 4 by M. K. Safaryan, chapters 5 and 6 by V. A. Afanas'ev, chapter 7 by B. V. Popovskiy and chapter 8 by O. M. Ivantsov.

Chapter One

GENERAL INFORMATION ABOUT OIL CENTERS

§ 1. Designation and Classification of Oil Centers.

The oil center is a complex, interrelated arrangement of buildings, installations, pipelines, storage tanks and special machinery.

An oil center is defined as a place which receives, stores, and delivers petroleum products. All operations carried out at the oil center can be classed either as basic or supporting.

The following operations fall into the basic category:

receiving petroleum products which have been delivered by rail tank cars, pipeline, tankers or other means;

storage of petroleum products in storage tanks or cargo containers;

delivering petroleum products to railroad tank cars, tankers and pipelines;

transfer pumping to main petroleum product pipeline stations;

delivery to small consumers via pumps and container warehouses.

The following operations fall into the supporting category:

purification and separation of water from petroleum products;

blending lubricating oils or fuels;

reclamation (restoring quality) of refined lubricating oil;

manufacture and repair of containers (barrels, containers); preheating congealed or viscous petroleum products during receiving, storage and delivery.

Oil centers are divided into two groups:

The first consists of those which are independent enterprises whose purpose is to store petroleum and petroleum products and to supply them to consumers;

The second consists of centers which belong to the industrial transportation system, or other types of enterprises (heat and electric power plants, railroad stations, river and sea ports, etc.).

Depending on firefighting requirements, centers in the first group can be subdivided further into the following three categories as a function of total oil farm capacity:

- category I - capacity is 50,000 m³ or more
- category II - capacity is 10,000-50,000 m³
- category III - capacity goes up to 10,000 m³

Oil centers in the second category are allowed to store the following quantities (in m³) of petroleum products in storage tanks or containers:

	Subterranean Storage	Surface Storage
Light Combustibles	4,000	2,000
Flammables	20,000	10,000

Oil centers are located in specially selected sites according to a general development and construction plan for a specified region: they are near transportation lines if the oil center is

a railroad type and near water routes, if the plan is to have the oil center receive and ship petroleum products by water.

Oil centers are tied to public roads by access roads at least 6 m wide. Oil centers in category I have at least two roads accessible to public roads. Category II and III oil centers have only one.

Category I oil centers are located at least 100 m away from industrial enterprises. Category II and III centers are 40 m away from industrial enterprises and 100 m away from other buildings.

Oil centers located on a shore line, or within 200 m or less from the shore, are set, as a rule, no closer than 100 m to traffic and, at least 3000 m (for category I centers) or 2000 m (for category II centers) away from traffic at docks, river stations, hydroelectric stations, bridges, or other industrial facilities not directly on the river bank.

If the oil center is closer than 200 m to a populated point, an industrial enterprise, or a railroad, and is at a higher elevation, then protective banks, water canals or other measures must be set up to prevent flow from the oil center in case of damage.

Oil distribution centers are built to a general plan which has included such items as building layouts, installations, facilities, transportation and industrial networks, maintenance, security, organization of public services, and road layout within the area. In general, the oil distribution center is divided into seven industrial zones with the following purposes (fig. 1.1):

- I - receiving and shipping petroleum products by rail;
- II - receiving and shipping petroleum products by water;

- III - security;
- IV - operations;
- V - supporting production process equipment;
- VI - administrative - management;
- VII - purification operations.

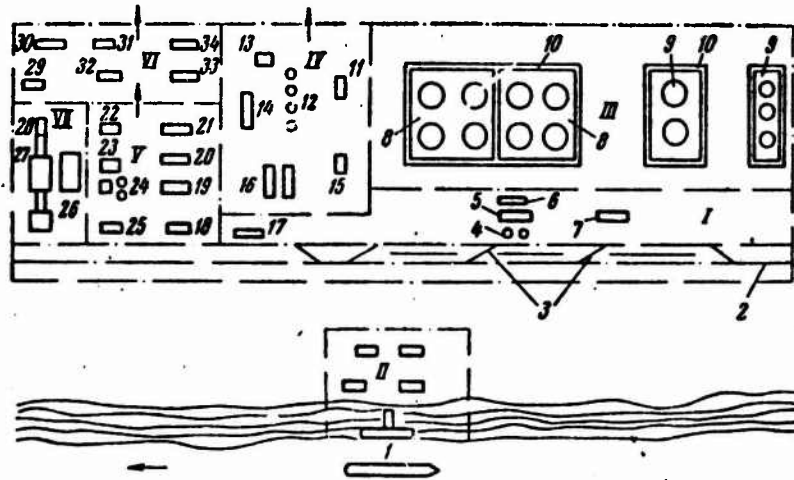

Fig. 1.1 Layout of a typical oil center by zones.

1- berth; 2- freight railroad tracks; 3- loading and unloading racks; 4- null type storage tanks; 5- office (pump); 6- gate valve junction; 7, 31- laboratories; 8- tank farms; 9- measuring tank; 10- embankment; 11, 15, 16, 18, 19, 25- stores; 12- auto pump; 13- weighing bridge; 14- pouring tank; 17- unloading area; 20- boiler room; 21, 22 and 23- engineering shop, 24- water pump area; 26- sludge bed; 27- oil trap; 28- sand trap; 29- administration building; 30- office; 32- electric power station; 33- security guard; 34- fire station.

Zone I contains buildings which receive or ship large batch lots of petroleum products. It has railroad tracks for handling oil freight cars, loading and unloading racks, and null type storage tanks to receive petroleum products from underground mains, laboratories, and other buildings.

In zone II of oil centers located on navigable rivers or seaways, we find berths (piers) for loading and unloading ships as well as other subsidiary buildings.

Zone III contains installations for storing petroleum products; there are tank farms, gas mains, and buildings for carrying out subsidiary operations.

The tank farms are the principal buildings in oil centers.

Items in zones I, II, and III are interconnected by pipelines so that petroleum products can be transferred while they are being received, stored or shipped.

Zone IV contains buildings which are used to ship petroleum products in tank-trucks, barrels, or cans. Included here are self service racks and pumps for pumping petroleum products into tank trucks; unloading and packaging facilities for pumping petroleum products into barrels and cans; and other service type buildings.

The zone IV section is located as close to the entrance as possible.

Zone V contains the boiler room, the engineering shop, various storehouses, water pumping station, and other auxiliary installations. The oil center's water supply can come from the municipal water supply system, artesian wells, or open reservoirs.

The office, fire station, and other administrative-management buildings are located in zone VI.

Zone VII contains a group of buildings which collect and purify industrial waste water and rainwater (sand and oil traps and sludge beds, etc.).

Living quarters for the people who work in the oil center are located in an area separate and apart from the center.

Sometimes, to reduce construction costs, the individual buildings in zones V and VI are combined, depending on their processing capabilities.

Not all oil centers have the buildings just listed because its makeup depends on the type of center it is, its capacity, its designation, and the nature of operations carried out there. For example, buildings in zone III (operations) are not found in transfer centers, and boiler room facilities may not exist at centers which process white oils (benzene, kerosene, diesel fuel).

§ 2. Classification of Oil Distribution Centers By Operational Activities.

Oil centers, depending on operational activity, fall into four classes: 1) transfer; 2) pre-factory; 3) delivery; 4) distribution.

The purpose of transfer centers is to transfer bulk quantities of petroleum products from one type of transportation system to another. The storage period at such facilities (except for centers on water routes which freeze over) is 12 to 34 days.

Transfer centers are situated at ocean ports, on navigable rivers, and at large rail truck lines.

Petroleum products are transferred from rail car or pipeline to tankers or vice versa at marine (ocean or river) transfer centers.

At those transfer centers which are situated on rivers which freeze over, and where petroleum cargoes are transferred from ship to rail, large oil tank farms receive petroleum products only during the navigable period, and ship during the remaining part of the year.

Powerful pumping equipment and modern input-output systems at the transfer centers make it possible to move cargo within a short period of time and without demurrage.

In general, transfer centers belong to category I.

Pre-factory oil distribution centers are raw material or commodity bases. Raw material bases receive and prepare raw material for processing at a factory; and commodity bases ship finished products to delivery and distribution centers.

Usually raw material and commodity bases are combined and located in close proximity to the factory or even within its confines. As a rule, pre-factory centers share power, water, and sewage facilities with the factory.

Delivery centers distribute petroleum products throughout an extensive network of small distribution points. They can also supply small consumers (integrated oil delivery centers).

Petroleum products arrive at oil delivery centers and are then moved to distribution bases by various methods of transportation.

Oil distribution centers supply consumers with petroleum products directly. Both the capacity and variety of petroleum products at distribution bases are smaller than that found in transfer or pre-factory centers. Distribution centers are not

intended to store things for long periods of time and service a limited region.

Distribution centers receive petroleum products by water or rail, and ship to consumers in rail tank cars, tank trucks, or other small containers.

Distribution centers located away from waterways or railroads are called interior centers. This is done in preference to calling them agricultural region oil centers which get their petroleum products by truck and distribute it in small containers (barrels, cans).

Centers which receive products by pipeline are situated along the main oil pipeline trunks. They deliver petroleum products chiefly by truck.

Distribution centers usually fall into categories II and III.

§ 3. Determining Oil Center Capacity

It is very important to know the oil center capacity to be able to increase its capacity in the future. A significant part of the capital investment (up to 60%) put into constructing oil centers goes for the tank farms; therefore, capacity must be fixed accurately enough so that the fullest use is made under normal circumstances.

Storage capacity in the tank depends on the type of base it is, material turnaround, receiving and delivery conditions, and also how many inter-warehouse operations must be performed (filtering, water separation etc.). Therefore, what type of

center it is (transfer, distribution, marine, rail) determines the amount of stored petroleum products; an increase in turn-around and any unevenness in incoming or outgoing deliveries contributes to increasing capacity. Additional capacity is needed for inter-warehouse operations.

Statistical data on petroleum product requirements within the particular area must be established and consumption forecasts must be considered, if distribution center capacity is to be found.

If the shipment is by rail, the capacity required at the center for each type of product can be determined from the formula

$$V = \frac{Q\tau}{30 \cdot 0.95\rho} \left(k_1 + 1 - \frac{1}{k_2} \right),$$

where V is the capacity in m^3 ; Q is the maximum monthly receipts in tons; τ is the tank car running time, in days, from where they were filled to the oil center; k_1 , is the coefficient of unevenness in the incoming delivery of products ($k = 1/1.5$ is a function of the tank car running time); k_2 is the coefficient of unevenness in outgoing deliveries of products ($k_2 = 1/4$); ρ is the density of the product in T/m^3 ; the number of days in a month is 30; and 0.95 is the storage tank utilization factor.

The capacity of oil centers situated on waterways which freeze over must equal requirements for the inter navigational period plus a certain reserve.

The capacity of a transfer center can be found graphically using incoming and outgoing delivery rates (fig. 1.2) during individual periods of the year (months).

If the oil tank farm is operating normally, this area bounded by the incoming delivery curve and the coordinate axes (fig. 1.2a) must equal the area bounded by the outgoing delivery curve and the coordinate axes (fig. 1.2b, both areas have been hatched), so that the products received, Q_i , equal those shipped out, Q_o . If we superimpose the incoming graph (a) onto the outgoing (b), we get another graph (c) in which the areas marked plus and minus show how much incoming deliveries exceed outgoing and vice versa. The sum of the positive areas equals the sum of the negative areas because input equals output. The points at which the two curves intersect indicate low or high points of product outgo.

When incoming deliveries exceed outgoing, storage tank capacity is filled (see curve oab, fig. 1.2d). Maximum capacity shows up at the end of a low outgo period (ordinate V_{\max}). Upon reaching its maximum (point b) the curve turns down (segment bcd) until the end of the high outgo period. Then the low outgo period starts again and the curve increases (dc), i.e., incoming delivery exceeds outgoing.

Oil tank farm capacity needed by the center is $V = V_{\max} - V_{\min}$. Let $V_{\max} = 25\%$ and $V_{\min} = -10\%$ of the annual handled, then the required capacity is $V = 25 - (-10) = 35\%$ of the annual turnover.

If petroleum products similar in quality are stored at the oil center (greases and different grades of diesel fuel) and the periods when they are filled to the maximum do not coincide, overall center capacity can be fixed at some figure less than the sum of all the individually calculated capacities.

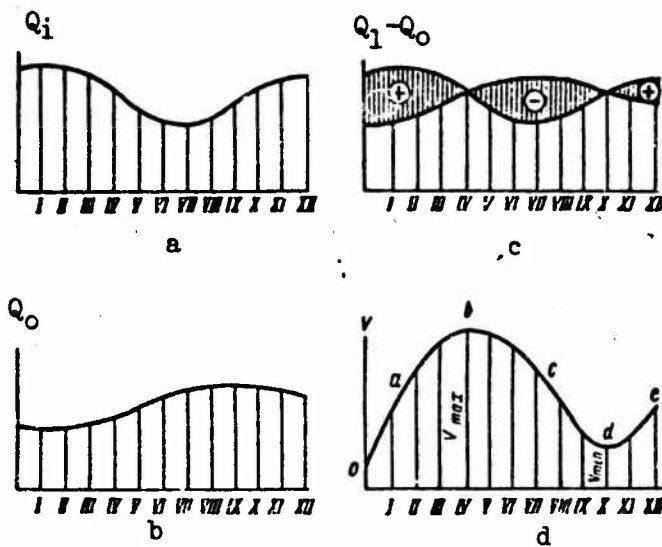

Fig. 1.2
Graphical method of determining oil center capacity.

Oil center capacity can be found analytically if incoming and outgoing deliveries can be established in terms of an annual turnover percentage or in actual amounts by months, ten day periods or weeks. Table 1.1 shows an example of how capacity can be found as a percentage of annual turnover; the first two lines show incoming and outgoing monthly deliveries as a percentage of the total annual handle; the third line is the monthly excess of shipments over receipts (-) or receipts over shipments (+) which appears as the difference between the first and second lines; and the fourth is the monthly change in oil tank farm capacity which appears as the sum of the monthly petroleum product balances.

(Table 1.1)

Indices	Jan.	Feb.	Mar.	April	May	June	July	Aug.	Sept.	Oct.	Nov.	Dec.	Total
Incoming	2	5	5	7	9	12	15	12	10	9	8	6	100
Outgoing	14	12	10	10	7	3	3	7	9	10	9	6	100
Monthly balance	-12	-7	-5	-3	+2	+9	+12	+5	+1	-1	-1	0	--
Sum of monthly balances	-12	-19	-24	-27	-25	-16	-4	+1	+2	+1	0	0	--

In our example the tank farm's capacity is $V = V_{\max} - V_{\min} = 2 - (-27) = 29\%$ of the annual turnover.

The capacity of measuring tanks, null type tanks and tanks for internal operations must be added to the capacity just found.

For planning purposes, capacity is found by using a utilization factor η and the relation $V_p = V/\eta$. An average value for η is 0.95. As a rule, the constructed storage capacity V_c is always higher than the planning figure V_p but the difference must be as small as possible.

The relationship of annual turnover to capacity is the turnover factor; this shows how efficiently the tank farm is being used and the figure varies from 1 to 30. Railroad oil centers have higher numbers while centers situated on rivers which freeze over have smaller.

§ 4. Selecting and Surveying An Oil Center Construction Site.

Before a site can be selected on the map, project engineers must carry out some preliminary work like the following:

- a) study the project specifications;
- b) familiarize themselves with site topography using existing maps and locate railroads and automobile roads;
- c) ascertain sources of water, electric power and telephone lines;
- d) determine local availability of construction materials;

Usually several different layouts of an oil center are possible so a special commission selects the optimum one after a review.

The site where the oil center is to be constructed must conform to the general plan for developing neighboring population centers and industrial enterprises.

The area set aside for construction must accommodate all the buildings in the oil center, provisions must be made for protection against fires and space must be set aside for expansion (usually 25-30% of the oil center's area). Wind directions must be established when laying out the area. The oil center is always located on the lee side of populated areas.

Area topography should be gently sloping so as to allow petroleum products to be filled or drained from pipelines by gravity and also to allow rainwater to drain away. Rugged or flat terrain is not suitable for oil centers because they require large expenditures to provide the planned topography.

Terrace-like areas on river banks are very advantageous for marine oil centers because ships can be loaded by gravity.

Once the area for building an oil center has been selected, project surveyors face the following work:

- 1) geological and hydrogeological investigations;
- 2) topographical survey;
- 3) collecting general information;

This work is done during geological and hydrogeological investigation phases:

- a) determine location of soil strata, their interdependence, and geological characteristics and make recommendations on selecting naturally sound foundation sites;

b) collect data on the bed recommended as the most naturally suitable foundation site;

c) determine the level and flow characteristics of subsurface water.

Depending on geological conditions, a number of holes are drilled in the area to explore bed formations and to construct a geological cross-section. In addition, bore pits are sunk and specimens (monoliths) are taken from the walls for laboratory investigation. Depth of the bore pits depends on the data obtained from the drilled holes.

When storage tanks are built above ground, holes are drilled at least 12 meters to bedrock to determine ground stratification. A geological cross-section is made of the area where petroleum products are to be stored.

When subsurface storage tanks are to be built, hole depths are 6 meters below the bottom of the tank and detailed data is taken on the location of subsurface water and on its chemical composition. A written report is made on the results of the geological and hydrogeological investigations and recommendations are made on how to design the foundations.

The extent of the topological survey is determined by local conditions - whether there are neighboring, developed areas, railroads, reservoirs, etc. The scale for surveying the section varies from 1:2000 to 1:500 depending on local topography. Contour lines are plotted at every 0.5 to 1 meter height above sea level and levelling is done on a grid square whose sides are 30 to 50 meters. A situation map is drawn up showing roads, rivers, gorges, buildings, borders of populated areas, water and sewage mains, etc. This is appended to the railroad map in which railhead elevations

above sea level are also indicated. All material on rail lines is coordinated with railroad management. Two baseline axes (mutually perpendicular) are drawn on the oil center plan and then duplicated at the site with benchmarks (buried posts). Local departments of various interested organizations (meteorological, real estate, archives, etc.) receive general information about the sites such as: geological and hydrogeological data, depth of the frostline and snow cover; air temperature by month; wind directions; area seismological data; water sources and usage potential; and information on roads; availability of local construction materials; electric power sources etc.

§ 5. Preparing a General Plan for an Oil Center.

The general plan is the most important part of the planning operation. Any errors made during preparation of the general plan can increase construction cost and have an adverse affect on the oil center's operation. The general plan must take into account the sequence of the oil center's processing operations; advantageous use of local topological characteristics; efficient integration of the area's engineering systems (waterlines, sewage, high voltage lines, low current lines etc.) and their respective communication channels, and of the oil center's roads; and there must be good arrangement of the individual zones to fit geological, hydrogeological, and meteorological conditions.

The following are used in preparing the general plan:

- a) a detailed plan of the areas abutting the oil center;
- b) a contour map plan of the oil center;
- c) information on fire fighting classification, depending on the oil center's category;
- d) a master list of the oil center (a list of all buildings);
- c) information about tank farm capacity.

Preparing the general plan is a complex problem which is solved by the combined efforts of production - process engineers, architects, builders, highway engineers, electrical engineers and water supply engineers. Solution of the problem begins at the planning stage which breaks down into horizontal and vertical type planning.

Horizontal planning means that all the oil center buildings are arranged in the plan so that there is a technical tie between individual zones. A process scheme is developed in the first stage of horizontal planning and all pipelines and building outlines are entered therein. The petroleum receiving zones (I or II) which are associated with rail lines or berthing facilities are located separately from the other zones. If a river is the water source, the water intake facilities are located above the docks. A parcel with the required subsoil properties is set aside for the most important zone in the oil center - the storage zone(III). Prevailing winds are considered so that no sparks are carried over from buildings in which open fires are used (boiler rooms, forges etc.). The storage zone is enclosed.

The operations zone (IV) is located directly at the entrance. At large oil centers (categories I and II) the operations zone is enclosed and designed to have a separate entrance and exit.

The auxiliary building zone (V) is usually set apart from the other zones because its sectors are interrelated and open fire can be used in the work carried on there.

The zone containing the purification facilities is located in the lowest section of the area in order to drain rainwater and sewage by gravity. The residential area is built a specified distance away, as determined by fire safety standards. Also

buildings are located within the zone, anticipating fires. Besides all this, horizontal planning takes care of road design, including 3.5 meter wide approaches to all installations within the center. Main roads are designed to be 6 meters wide. It is advisable to link roads together to facilitate fire engines' movement.

Vertical planning involves organizing area topology to drain rain, designing road gradients and engineering support systems, and also marking the first story for buildings and storage tank bottoms. This work is done to meet the technical requirements of tall buildings. They must provide for the following:

gravity loading or unloading of petroleum products into or from rail tank cars and gravity feeding into the operational zone;
locating the storage zone at a site lower than the surrounding installations to avoid spreading spilled products in case storage tanks are damaged.

Pumping stations are also located in the lowest spots so that suction lines operate properly. Maximum road grade lengthwise is 0.07 and transversely is 0.04.

To determine the scope of earth moving work (fills and excavations) the oil center is divided into quadrants 20 meters to the side and the quadrant points of intersection are marked in black, if they represent current levels of the earth's surface, or in red, if according to the vertical planning design. The basic purpose of vertical planning is to balance out earth moving work so that excavations equals fillings.

§ 6. Planning Oil Tank Farms

The following requirements apply to storage tanks which are intended to be used to store petroleum and petroleum products:

1) hermeticity; 2) fire proofing and 3) life.

Storage tank parts must be manufactured under industrial conditions and must be easily assembled at the construction site.

The following indicators evaluate oil tank farms technically and economically:

1) cost per m³ of capacity;

2) overall cost per m³ of capacity which consists not only of the storage tank itself, but also the cost of other necessary construction in the oil tank farm (earth moving work, industrial work, water supply and sewage, heating systems, roads, enclosures etc.);

3) the expenditure for basic construction materials (steel, reinforced concrete etc.).

Petroleum and petroleum product storage tanks can be surface types, if their bases are at a uniform level, or above the lowest planning mark in the adjoining area, or if they are set at a depth which is less than half their height; or else underground types, if the highest level of fluid in the tank is lower than the lowest planning mark in the adjoining area by at least 0.2 meters.

Comments. 1. The adjoining area is considered to be within 6 meters of the tank wall.

2. Tanks which have been banked with earth are considered to be underground types providing the height of the embankment is at least 0.2 meters higher than the highest level of fluid in a tank and at least 6 meters wide as measured from the bank wall to the embankment edge.

Tank shape may be cylindrical (vertical or horizontal), rectangular, spherical, tear shaped etc. Tank capacity is regulated by fire safety standards and technical considerations. The following data must be known to layout oil tank farms:

for surface tanks

- the largest capacity within a group of tanks
- the distance between walls of neighboring tanks which comprise the group
- the distance between tank groups
- the order in which tanks are located within a group.

for underground tanks

- division of tanks into groups and subgroups; group and subgroup capacity is regulated by the product's surface area;
- the distance between groups, subgroups and the distance between neighboring tanks within a subgroup.

In order to forestall spillage of petroleum or petroleum products because of damage, surface tanks are enclosed with an uninterrupted, earthen embankment at least 1 meter high and at least .5 meters wide on the top of other incombustible material at least 1 meter high and which is designed to withstand the hydrostatic pressure produced by the spilled liquid. Fire safety standards are followed in building embankments within groups.

Investigation of technical-economic indicators on both surface and underground types of oil tank farms shows that an increase in capacity significantly reduces the amount of basic materials expended as well as construction cost. In particular, it was noted that pipeline distances (industrial, water supply, sewage etc.) were shortened. Moreover, according to information from V. I. Chernikin, increasing the capacity of individual tanks cuts down evaporation losses. For example, the annual evaporation

loss for a 200 m³ tank is 5.75%, for 400 m³ it is 5%, for 1000 m³ it is 4.25%, for 2000 m³ it is 3.75%, for 5000 m³ it is 3.25%, and for 10,000 m³ it is 2.75% of total tank capacity.

§ 7. Oil Center Loading and Unloading Devices

The purpose of this book is to familiarize the reader chiefly with problems having to do with the construction of oil centers. Therefore, we shall describe here only the more commonly used railroad loading and unloading devices.

Special scaffolds have been built to load petroleum products at main rail trunk lines and to unload them at the storage tanks. Scaffolds are spotted directly on that section of the rail line (rail head) which leads away from the nearest station. Petroleum handling rail track can be either operational (loading - unloading) switching, or by-passing, so changes can be made if other tracks are taken up, and also there is a railhead to unload crates, coal and other materials. Loading - unloading devices are built of fireproof materials and can be either single or double track types (between two tracks).

Petroleum products having different properties (viscosity, pour points, vapor pressure etc.) arrive at the oil center in different types of tanks. This requires different loading and unloading systems.

Unloading by pumps (fig. 1.3a) can use either topside or bottomside methods. In the topside method of unloading, the standpipes 1 are set 4 meters apart and are connected by flexible rubber hoses 2. The other end of the hose runs through the access hatch into the tank car.

If the bottomside method is used, the tank car discharge fittings are connected by flexible hoses 3 to the manifold 4.

A drainpipe 5 runs from the inside of the suction manifold 4 to the pump 6. A cleaning manifold which runs in parallel with manifold 4 is connected to standpipe 1. If the centrifugal pumps are not self-priming, then a vacuum pump is connected to the air manifold 7 to create the initial vacuum in the suction line. The vacuum pump exhausts any air in the line due to loose connections. Petroleum products are pumped directly into the tank farm or first into a null type tank 8, and then into the tank farm. The unloading lines are hermetically sealed.

Topside unloading with a submersible pump (fig. 1.3b) is done in the following way. A flexible hose 2 is connected to a submersible pump and an explosion-proof electric motor. The pump transfers the petroleum product from the tank car into the storage tank 8 through hose and pipelines 1, 4, 5.

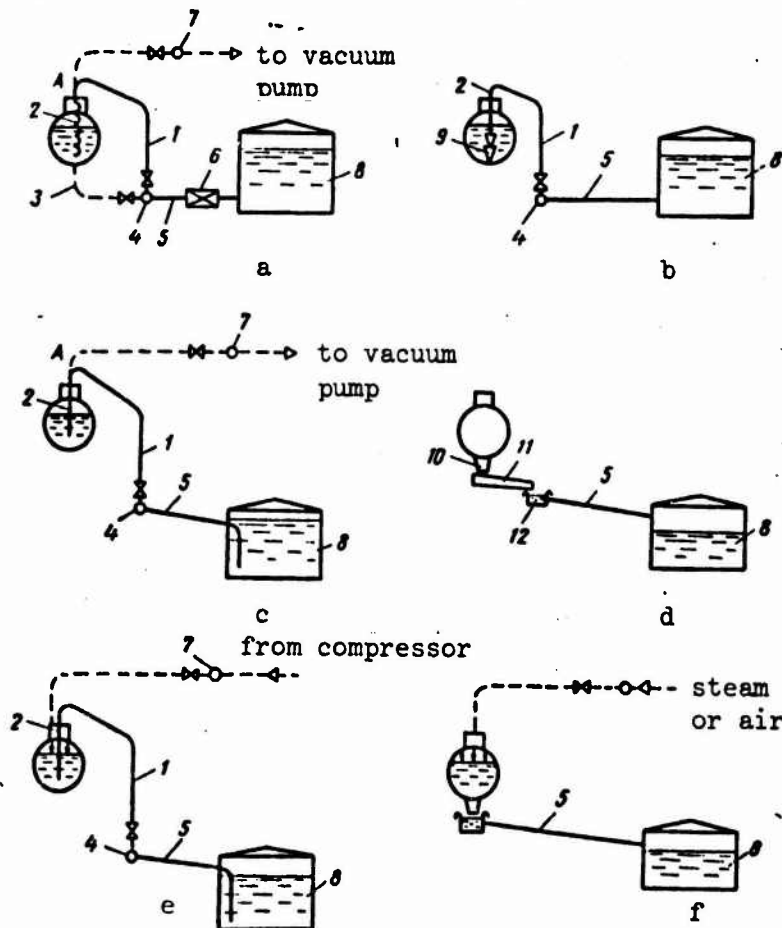

Fig. 1.3 Methods of unloading petroleum products from tank cars.

Gravity discharge (fig. 1.3c, using the same marking system as for a and b) is used when topography is favorable and when storage tanks are located beneath the tank cars. The discharge standpipe is, in effect, a syphon. There is no pump in the system during gravity discharge. However, in order to have normal discharge conditions, the upper point of the discharge standpipe A must be connected to a vacuum pump.

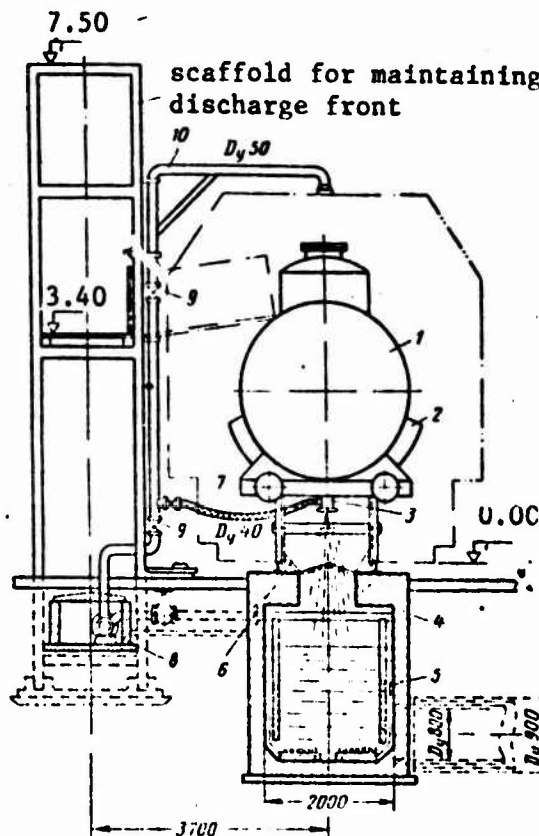

Fig. 1.4

Discharge of dark petroleum products using an intra-rail trough and a fixed, coiled heating element.

1- four axle tank car with a capacity of 50 m ; 2- tank car steam jacket; 3- discharge fitting; 4- reinforced concrete trough in between the tracks; 5- coiled heating elements in the trough; 6- metal covers for the trough; 7- steam hose $D_y=32$ mm; 8- steam line; 9- shut-off valve $D_y=32$ mm.; 10- rotating pipe $D_y=50$ mm for connection to the hose when heating fuel oil with live steam.

Open gravity discharge (fig. 1.3, d) differs in that the petroleum product passes through the tank car's discharge apparatus 10 into chutes 11, and along this into a trough 12, placed alongside the rail line. The petroleum product discharges into tank 8 through discharge pipe 5, attached to the center of the trough.

Petroleum products are pumped from the decanting tank 8 into the storage tanks. Decanting (null type) tank capacity is equal to either the full cargo capacity or $2/3$ of it, if the petroleum products are pumped directly out of the delivery tank. The delivery trough and chutes are made of incombustible materials. The chutes are about 3.5 meters long. The delivery trough can be located either alongside the track (one-sided delivery), between tracks (intra-track delivery), or between a pair of tracks (two-sided delivery). The trough is as long as the road bed. Heaters, steam pipes 25-50 mm in diameter, are placed along the bottom of the trough when viscous petroleum products are being unloaded. The trough has hinged covers. Figure 1.4 shows the unloading of dark petroleum products using an intra-track trough with fixed, coil type heaters.

The enclosed gravity unloading system differs from the open in that instead of using delivery chutes under the tank car discharge fittings, flexible hoses are used and these run to the unloading manifold. The manifold is buried in the ground at some angle and a discharge pipe is attached at its center.

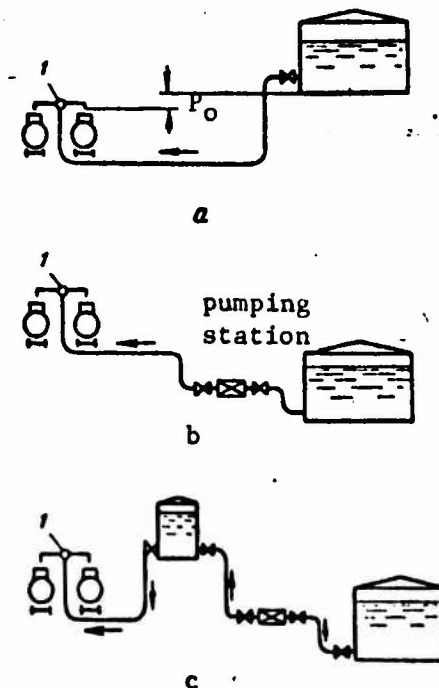

Fig. 1.5
Methods of loading petroleum products.

A pressurized unloading system (fig. 1.3, e, f) is used to speed up the discharge process. Here the tank car access hatch is hermetically sealed by a special cover which contains a nozzle and this is connected to an air or steam manifold via a flexible hose. The air or steam increases surface pressure (0.5 Kg-f/cm^2) and the discharge is accelerated. The tank car cover has a safety valve and a manometer. When the topside method of unloading (fig. 1.3,e) is used, pressurized material moves through the hose 2 and pipes 1, 4 and 5 into the unloading tank 8. The pressurized bottom method is chiefly used in handling viscous products; it is very efficient and reduces pre-heating. If the trough is located between rails (this simplifies unloading) then heaters are put along the trough's walls and the trough must be set deeper. Petroleum products flow from the drain pipe 5 into the storage tank 8.

The same facilities used to unload white petroleum products are used to unload petroleum products into tank cars.

Figure 1.5 shows how petroleum products are loaded.

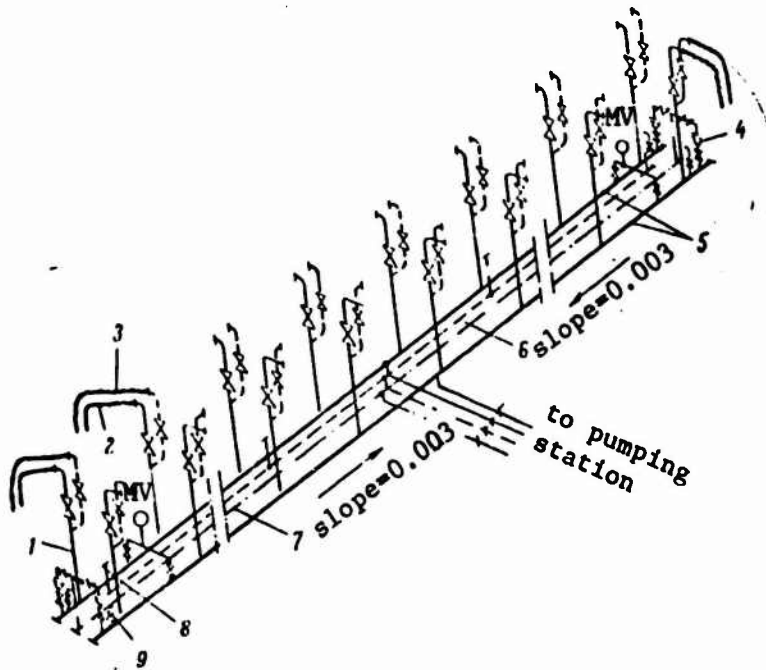

Fig. 1.6 Process schematic of a KS scaffold (combination loading and unloading of white petroleum products).

1- loading-unloading standpipe; 2- (main) rubber hose; 3- (purification) rubber hose; 4- air relief coils; 5- main manifolds; 6- manifold for unloading improperly working tank cars; 7- air manifold; 8- short pipes for unloading improperly working tank cars; 9- air release valve for use when the manifold is being discharged.

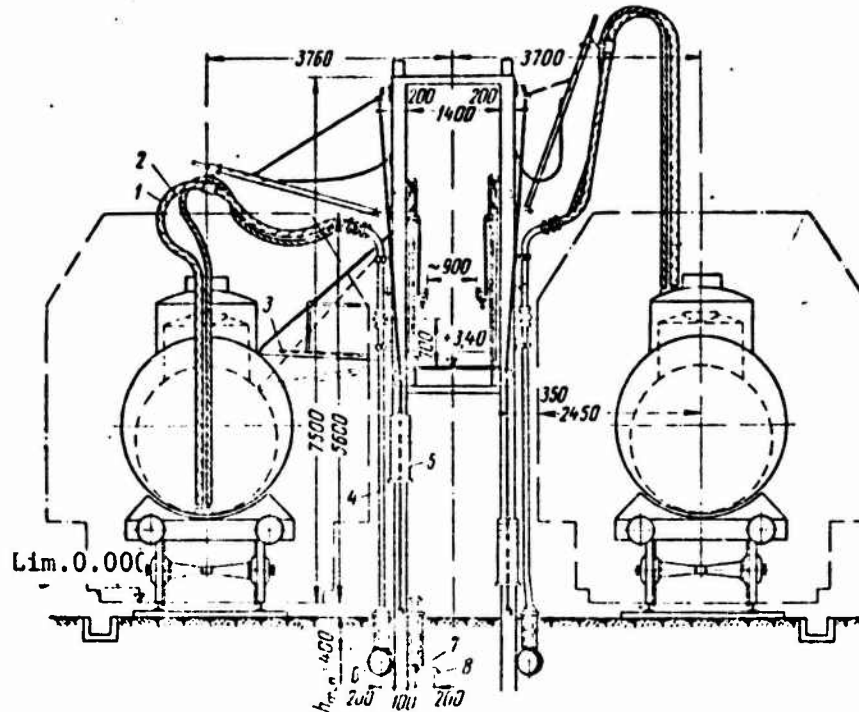

Fig. 1.7
KS scaffold with rubber hoses.

1- hose where $D=76$ mm; 2- sleeve where $D=38$ mm; 3- mobile, collapsible bridge; 4- standpipe; 6- counter-weight; 7- manifold for unloading improperly working tank cars; 8- air manifold.

Gravity loading (fig. 1.5) is used when topography permits and it takes place because there is a difference in height between

the petroleum product in the tank and the top of the scaffold.

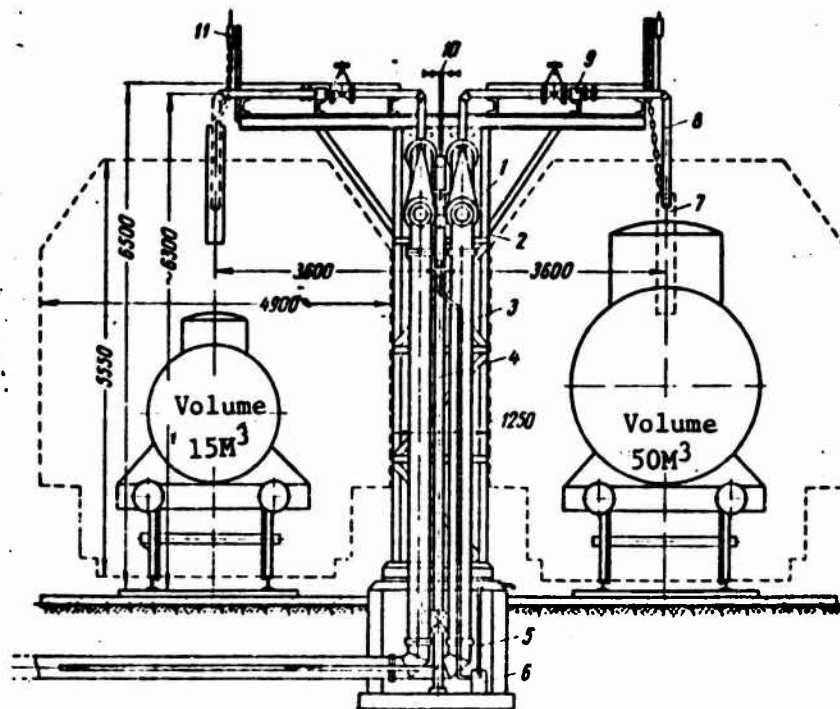

Fig. 1.8

NT type scaffold for loading dark petroleum products.

1- basic manifolds; 2- steam manifold; 3- drain pipe; 4- steam line; 5- condensate return line; 6- condensate return trap; 7- telescopic tube; 8- loading pipe; 9- rotating stuffing box; 10- steam nozzle; 11- counterweight.

Pressure loading (fig. 1.5 b) is done with pumps.

Loading via a buffer tank (figure 1.5 c) includes the first two devices and is done when the oil center's topography is favorable.

Loading and unloading is done at rail routes with scaffold 1. The number of scaffolds and their spans is a function of volume and freight capacity at the rail lines.

Loading and unloading scaffolds for white oils have two or three main manifolds, a manifold for unloading improperly working tank cars and an air manifold. Manifold diameters depend on freight capacity and are determined by hydraulic calculations.

NS, KS, NM and KM railroad type scaffolds can be made either of metal or reenforced concrete. They are fitted out with a water pipe system which delivers water with at least 25 horsepower at a pressure head of 40-60 meters and they have sewage system or open chutes (in southern regions) which can drain water or different types of petroleum products. The scaffolds are equipped with transition sections and hinged bridges to facilitate the loading-unloading operation. A schematic diagram of a KS type scaffold is shown in fig. 1.6 and in figs. 1.7 and 1.8 are shown KS and MT types.

§ 8. Water Supply and Sewerage Systems at Oil Centers.

Water is distributed at oil centers for industrial, house-keeping and firefighting purposes. Its consumption is regulated by special standards. As a rule, the water supply system at oil centers is integrated, i.e., there is one overall system and facility for delivering water for industrial - firefighting and housekeeping purposes. Separate systems are set up only when the quality of water for housekeeping purposes does not meet sanitary requirements and must be purified. Local watermains, artesian wells, or intakes from open sources (rivers and lakes) are water supply sources. Category I and II centers are always equipped with a firefighting water system, while category III centers have firefighting water tanks or reservoirs which deliver water by motor pumps or firefighting pumping units. There are usually at least two water tanks or reservoirs, the volume of each is at least 100 m³ and the distance from the water tank to a building is no more than 200 m and no less than 40 m.

Foam is mainly used to extinguish fires in oil tank farms - it can be chemical and made by mobile foam generators or pneumatic-mechanical and made by foam mixers. Water is delivered to the foam generators or mixers from the pipeline at a pressure of at least 4 lic.-f/m². Information on water expenditure for these purposes is given in table 1.2.

The oil center s sewage system is always designed in two sections; one for industrial-rainfall drainage and the other for housekeeping and human waste discharges. Those systems are never combined. Figure 1.9 shows the main layout of a sewage disposal system at an oil center. If ethylated gasoline is stored at the center, industrial-rainfall drainage is piped into separate tanks and then purified. The industrial-rainfall system is no closer than 3 meters to the housekeeping and human waste system. The waste disposal system (gravity type, as a general rule) is designed to be underground, and is built with cast iron, ceramic or asbestos-cement pipes. The distance between an oil trap and the closest building is at least 30 meters.

(Table 1.2)

Tanks	Tank Volume	Discharge of water liters/sec.			
		for foam extinguishing	for cooling a heated tank	for cooling three adjacent tanks	Total
Surface metal	700	12	17	10	39
	1000	12	19	11	42
	3000	40	30	18	88
	5000	50	36	22	108
Underground reinforced concrete	5000	55	30	-	85
	10000	105	50	-	155

Note. Shown is the amount of water which must be expended for petroleum products whose flash point is 28°C or less; the amount of water needed to extinguish with foam petroleum products whose ignition point ranges from 28 to 45°C decreases by 17% and for ignition points over 45°C by 50%. Calculated time for extinguishing the fire is 10 minutes and 3 hours for cooldown.

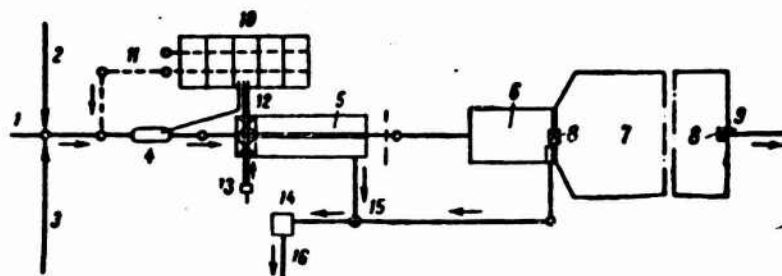

Fig. 1.9

Main layout of an oil center sewage system. 1- building industrial waste system; 2- scaffold waste disposal system; 3- oil tank farm waste disposal system; 4- sand trap and strainer piping; 5- oil trap; 6- first section of the purification pond; 7- second section of the purification pond; 8- discharge control; 9- basin discharge; 10- precipitation drying area; 11- drainage network; 12- dredge pipeline; 13- dredge pipeline output to ejector; 14- pump station for pumping out accumulated petroleum products; 15- reservoir for accumulated petroleum products; 16- network to separator-reservoir.

At large marine oil centers the ballast water (from tankers) as well as sewage water is purified. Large and complex installations are set up to do this; they have oil traps, settling tanks, storage tanks, flotation beds and other special equipment. Purification facilities are designed to meet special standards and industrial conditions.

Chapter Two

STEEL STORAGE TANKS

§ 1. Present Day Status of Storage Tank Construction.

Today steel storage tanks, which are designed to withstand low gas pressure differentials (2000 mm of water) fall into two categories:

- 1) vertical, cylindrical types which are distinctive because of size and the enclosed construction;
- 2) trench type.

All modern storage tanks are built to standard designs. Sizes run in series and low pressure steel storage tanks come in the following capacities (dimensions in m^3): 100; 200; 300; 400; 700; 1000; 5,000; 10,000; 15,000; 20,000; 30,000; 50,000; 100,000.

Storage tanks with capacities up to 30,000 m^3 are built exclusively by the industrial method using rolled stock; storage tanks with capacities of 50,000 and 100,000 m^3 are built by the plate stock method. However, 50,000 and 100,000 m^3 storage tanks will be built by the industrial method shortly. This forecast is based on using new wall construction techniques (for example, a double layered wall) and the possibility of using high strength steels (S-45 and S-60 classes).

Trench type storage tanks are normally built with a 5,000 m^3 capacity but they can be expanded to 10,000 m^3 if these technical-economic features have been considered.

At present the trend abroad is to build vertical cylindrical storage tanks with large capacities. For example, there is a tank with a capacity of 100-120,000 m^3 . The majority are fitted with breather roofs.

§ 2. Design Characteristics of Steel Storage Tanks.

Operating conditions, properties of petroleum and petroleum products, construction and design requirements and steel properties are all considered during the design of steel storage tanks.

By the term operating conditions we mean geographical and climatic conditions at the construction site (positive and negative temperatures); soil conditions and the possibility of uneven settling; the turnover factor - the number of times the tanks are filled and emptied; the reactive nature of the petroleum products and the likelihood of creating a significantly excessive pressure during filling or a vacuum in emptying hermetically sealed storage tanks.

Properties of Stored Products and Usage Conditions

Petroleum, petroleum products and gas each have special properties which significantly affect how they are stored. The most important of these is their flammability and tendency to explode as well as their tendencies to form static charges. Several types of petroleum and petroleum products are highly volatile and viscous.

The white oils (natural gasoline, aviation and automobile gasoline) and petroleum which contains a significantly large amount of light fractions (light crudes) are very volatile. Because these fractions do evaporate, part of the stored petroleum product is lost and its quality is lowered, so that frequently it is not suitable for direct use and must be "corrected".

Petroleum product evaporation losses damage the economy. It happens because of the following reasons:

1) venting gaseous area when access hatches are opened or because of "gas siphoning" which occurs when openings are at various levels;

2) "large scale breathing" while petroleum products are filled or emptied;

3) "small scale breathing" which happens when gas zone temperature rises and vapor concentration increases, or when the gas is distributed over a wider area because atmospheric pressure is lowered; "small scale breathing" occurs when the amount of petroleum products in the storage tank is constant;

4) saturation of petroleum product vapors throughout the tank's gas region;

5) boiling off of petroleum products due to heating because the vapor partial pressures are greater than the pressure at the petroleum product surface.

Investigations have shown that gasoline losses due to "small scale breathing" can be completely eliminated if the following maximum excess pressures (kg-f/cm²) are maintained in the vapor region:

in central Asian area	0.26
in remaining southern areas	0.19
in temperate areas	0.16
in northern areas	0.15

The following are the chief constructional techniques of reducing evaporation losses in petroleum products.

1. Reduction of the gas space. If there is no gas space, then theoretically there are no losses due to "breathing". Therefore, holding the gas space to a minimum is one of the ways to reduce evaporation. This can be done, for example, by using storage tanks which have breather roofs or pontoon roofs.

2. Increasing the excess gas pressure. "Small scale breathing" losses are completely eliminated, if petroleum products are stored under a specified excess of pressure.

3. Entrapment of petroleum product vapors. In this case the storage tanks are fitted out with gas collectors.

Selecting the Types of Steel Storage Tanks To Store Petroleum and Petroleum Products.

White petroleum products which have high boiling points (kerosene, natural gasoline and topped petroleum), oils, and grease have a low vapor pressure. Therefore, they can be stored in vertical, cylindrical storage tanks under an excess of pressures up to 200 mm of water.

Petroleum crudes and white oils (aviation and automobile gasolines, ligroine) have a vapor pressure which ranges from 0.4 to 1.2 kg-f/cm² at temperatures from 40 to 50°C. These types of petroleum products can be conveniently stored in droplet shaped, horizontal cylindrical storage tanks or in tanks which have spherical roofs.

The vapor pressure of white oils with low boiling points (priming fuel and natural gasoline) ranges from 1.2 to 2.0 kg-f/cm². These, therefore, are stored in horizontal cylindrical or spherical tanks.

To eliminate losses caused by "large scale breathing" at places with a high turnover factor (operational storage tanks, and tanks at main pipeline stations, etc.) it is preferable first to use tanks which have breather or pontoon roofs, or next to pressurize them, or as a last resort, to use vertical, cylindrical tanks which have low pressure gas compensation.

Petroleum products with low boiling points are stored in spherical or other type tanks which have been pressurized. If the turnover coefficient K_0 gets smaller, the efficiency of pressurized tanks increases. When K_0 is less than 6, they are more economical than breather roof type tanks.

Pressure tanks, tanks which have variable gas volumes, and vertical cylindrical tanks with low pressure gas equalization systems are used to avoid "small scale breathing" losses.

White oils with high boiling points (tractor and lamp kerosenes, heavy crude and topped petroleum), for the most part, are stored in vertical, metal storage tanks.

Lubricating oils are chiefly stored in vertical or horizontal tanks and less frequently in specially lined reenforced concrete tanks.

The dark petroleum products (heavy diesel, high speed diesel and furnace fuel oils) are stored in standard metal, reenforced concrete, or stone storage tanks; while high-viscosity dark products (bitumens, residual oils and tar oils) are stored in reenforced concrete tanks.

Sour crude and its products are stored in tanks which have been treated with a special protective coating to guard against corrosion.

Construction and Design Requirements

In designing steel works, including plate type storage and gas tanks, the Soviet school of construction is guided by three principles: use the most economical metal, the least amount of

labor and the most rapid form of assembly. According to N. S. Streletskiy, one of the founders of the Soviet school of design these principles are equally valid and equally important and form the basis for quality in the design.

Improving quality is a serious problem and is the basis for "Construction Standards and Rules (CSR)".

In most foreign countries the safe working stress is used as the standard for strength and reliability; it is defined as the ratio of the maximum unit stress to a safety factor which is selected arbitrarily because it is indeterminate.

According to design practice in the USSR, the critical state of the construction is the standard for strength and reliability; this means it relates to the real application and to several factors which describe possible load changes, material quality, and construction work conditions. This type of design is labelled "designing to critical states" and the coefficients (load, uniformity and working conditions) are called design coefficients.

Domestic Steels For Constructing Storage Tanks

Storage tanks, gas containers and other petroleum and gas storage facilities are all domestically designed installations. They are intended to be used to store expensive products important to the economy. Quite frequently the item being stored (gasoline and liquified gas) is many times more expensive than the facility itself. The storage area must operate under a wide variety of climatic conditions, even at temperatures of -40°C and lower. Oftentimes the storage areas contain products which react quickly with steel and this causes corrosion.

The steel used to make storage and gas tanks must be strong (tensile strength, yield point, elongation etc.), its chemical composition must have the necessary welding properties, and it must resist brittle rupture at low temperatures (there must be enough impact strength and a low cold short cut off point).

The following types of steels are widely used in the domestic construction of storage tanks: low carbon steel BST. 3 per state standard (GOST) 380-71; low carbon steel St. 3 which has been improved by killing according to technical specification for ferrous metallurgy (ChMTU) 5232-55, and low alloy steel 09G2S(M) per state standard 5520-62. All these show higher impact resistance at low temperatures.

Strengthened or high strength low alloy steels (S-45 and S-60 classes) will be used to build storage tanks in the future. A tank with a capacity of 30,000 m³ has already been designed and built from 16G2AF steel which has a proof stress of 45 kg-f/mm². The use of such steels makes it possible to lower storage tank weight significantly and to widen the use of rolled stock.

At modern construction sites higher strength steel is often used to make the base perimeter and lower sections in the storage tank walls. Rimming steel is used for auxiliary construction (fences, staircases).

§ 3. Vertical, Cylindrical Storage Tanks Built From Rolled Stock

Storage Tanks Which Have Conical Protective Coverings

Until 1952-1953, welded storage tanks were built from plates. In 1953 the State Pedagogical Institute (GPI) Promstroyproyekt developed standardized vertical, cylindrical, storage tank designs

which differ significantly from the plate construction method not only in its construction features but also in the type of steels and electrodes. These tanks were to be assembled from rolled stock. The lower four wall bands were butt welded into a circle and the upper bands were lap welded. Vertical seams in all belts were welded. In new designs the rolled walls are butt welded vertically and around the circles, then all vertical seams are joined.

The method of building covers for tanks with a capacity of 1000 m³ or more using a semi-truss, purlins, radial members and fasteners was replaced by a prefabricated cover developed by V. V. Didkovskiy. The panels, which look like trapezoids with curved bases and are built at factories, have fasteners along radial and circular load bearing points (channel sections and angles) and are covered with 2.5 mm thick sheet steel. They bear against the tank's wall and against a post installed at the center. The central post is made of tube stock. The bottoms of tanks with a capacity up to 1000 m³ are made of 4 mm thick sheet steel. In tanks which have a capacity of 2000, 3000 or 5000 m³ the central section of the bottom and the edges are 4 and 6, 4 and 7.5 and 4 and 8 mm thick respectively. The bottom piece diameter is 100 mm larger than the tank diameter.

In 1957 Giprosnetspromstroy developed designs for tanks with frame and panel type covers which had capacities of 100, 200, 300, 400, 700, 1000, 2000, 3000 and 5000 m³.

Fig. 2.1 shows a 5000 m³ tank with a frame and panel cover.

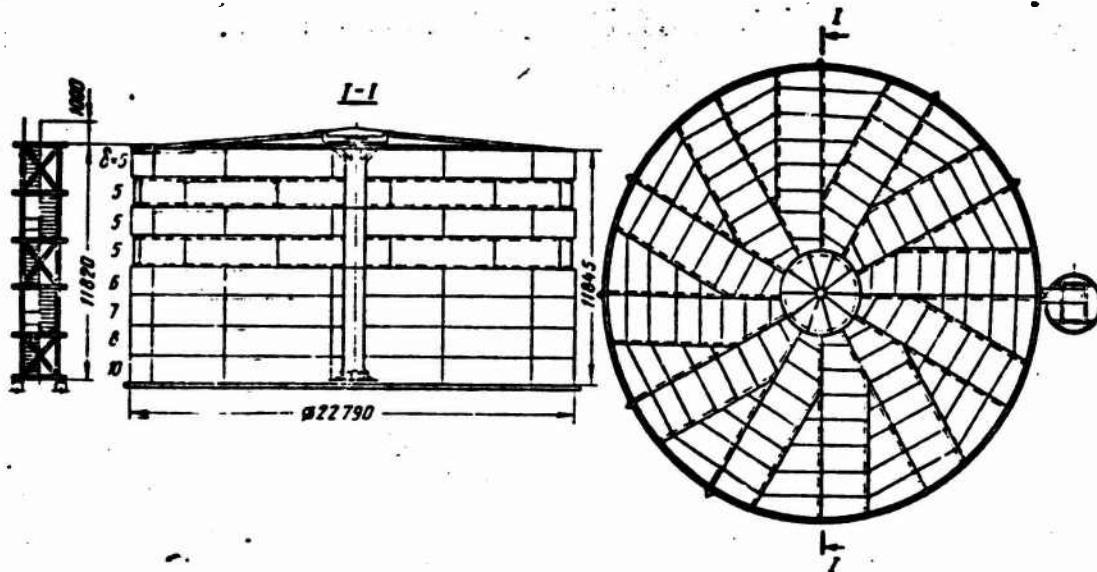

Fig. 2.1. A 5000 m³ storage tank with a frame and panel cover

Storage Tanks With Spherical Frame and Panel Covers

In designing storage tanks with a capacity greater than 5000 m³ the conical type frame and panel cover becomes complicated and uneconomical. Because of this Giprospeftneft' developed a design for 10,000 and 20,000 m³ storage tanks which had spherical covers (no central post). The 10,000 m³ storage tank (fig. 2.2) is 34.2 m in diameter and the walls are 11.88 m high. If the walls are made from V. St.3 steel, band thickness (from bottom to top) are: 14; 12; 11; 9; 7; 6; 6 and 6 mm. Such walls can easily be made from rolled stock. The wall is made in two layers.

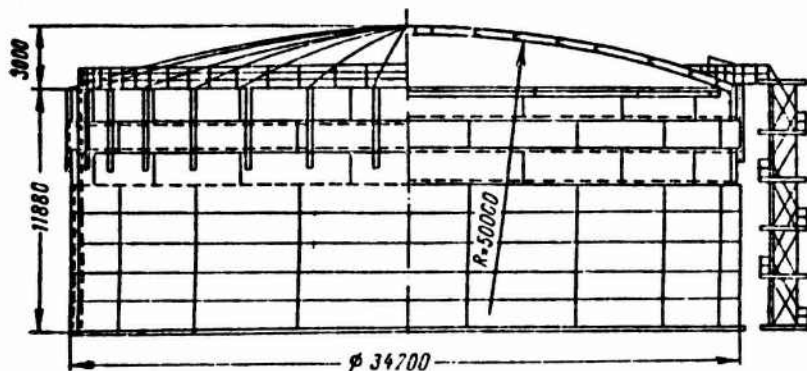

Fig. 2.2. A 10,000 m³ storage tank with a spherical type cover.

The spherical cover is made from 32 spherical panels. Radial ribs are made from No. 24 I beams and angles while the circular ones are made from No. 14 and 10 channels. The periphery of the cover rests against a ring made of No. 24 channel and a rigid welded ring formed as an I beam 708 mm. high. The roof covering is 3 mm thick and at the edges it is 8 mm.

The radius of curvature of the cover is 50 m and the dome altitude (peak of the arch) is 3m. Bottom edges are 10 and 8 mm thick and the central section is 5 mm.

The diameter of the 20,000 m³ storage tank (fig. 2.3) is 45.64 m and wall height is 11.92 m.

The storage tank wall is made up of eight bands; the four lower ones are 14, 12, 10 and 10 mm thick, respectively and are made from low alloy 09G2S steel; the four upper ones are 10 mm

thick and are made from St. 3 steel per technical specification (ChMTU) 5232-55. The walls are three-layered.

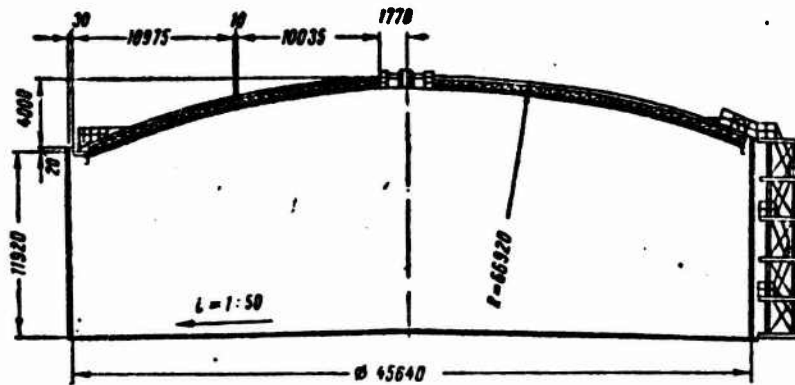

Fig. 2.3. A 20,000 m³ storage tank with a spherical cover.

The storage tank bottom edges are segmented and are 10 mm thick 09G2S steel. The center section is 6 mm thick St. 3 steel per ChMTU-5232-5, and made up in four layers.

The spherical cover is assembled from 48 prefabricated panels. The panels are ribbed; the radial ribs have box sections made from two No. 20 channels and have a series of angle brackets; the circular ribs are made from No. 8 and 6.5 channels. Roofing cover thickness is 30 mm and 10 mm at the edges.

Storage Tanks With Momentless Covers

In 1952 A. S. Arzunyan suggested a new type of covering which is the so-called "momentless covering" (fig. 2.4), i.e., a cover made of 2.5-3.0 mm thick sheet steel which bears against a central column and the storage tank wall and, except for the edges, works on the principle that steel can be stretched under optimum conditions.

The walls and the bottom of these types of storage tanks are the same as in standard vertical, cylindrical tanks. A column is set at the center of the tank and the other end holds a metal canopy (fig. 2.4 c,e). The upper surface of the wall has been reinforced with a box-shaped framework in order to increase rigidity and thrust.

The central column in storage tanks with a capacity of 3000 m³ is made out of pipe 325 mm in diameter and is set 1.5 to 2.0 m higher than the storage tank walls; the inclination facilitates precipitation drainage. The canopy for 3000 and 5000 m³ storage tanks is made from 8 or 10 mm thick sheet steel. The canopy is connected to the pipe by a welded bracket.

The central column is set up on a special shoe (fig. 2.4, d) set on the bottom of the storage tank. Two types of column construction have been developed: 1) a tube which has been hermetically sealed to the bottom by welding, 2) a tube which slips into a shoe.

An upper peripheral frame (fig. 2.4, f), a stiff wheel, is welded to the wall; this is made from four angles which go around the perimeter. All these angles are connected to one another radially with other angles and straps at fixed distances. Four mm thick steel is placed around the frame. In 1000 and 2000 m³ storage tanks the frame has one or two sets of angle brackets located in a circle in addition to the angles which are tied to the walls. No peripheral frame is made for storage tanks with a capacity less than 1000 m³.

Storage Tanks Which Have Pontoon or Breather Roofs.

A circular membrane is used to close off the liquid surface in a storage tank to minimize evaporation losses. A welt is put

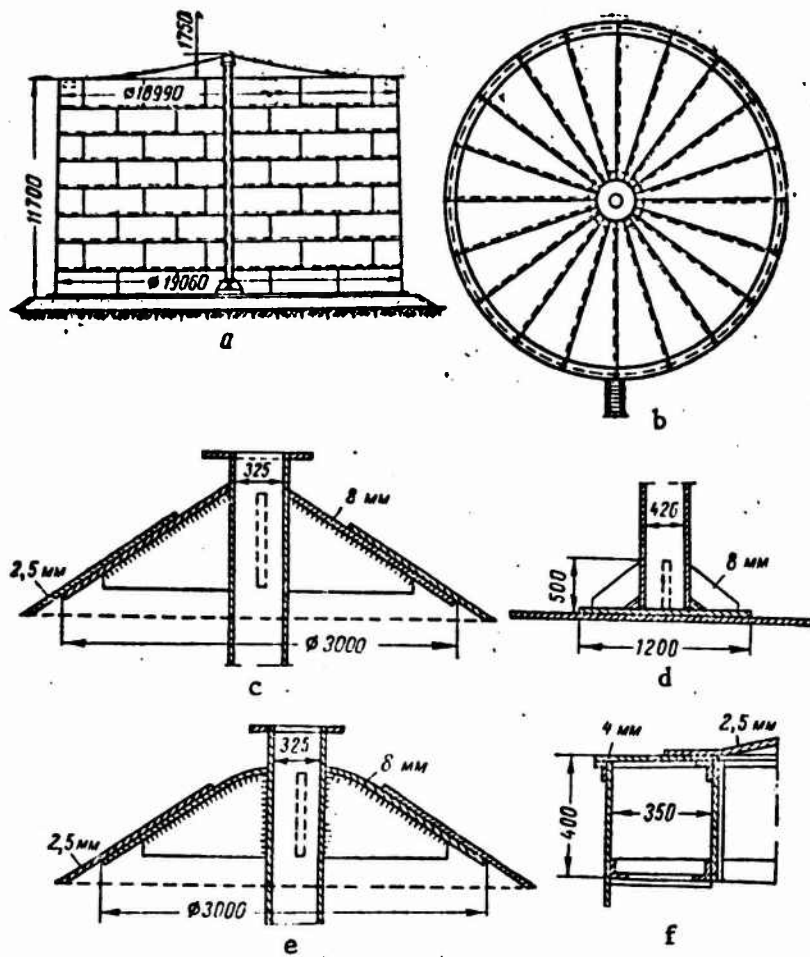

Fig. 2.4. A 3000 m³ storage tank with a momentless cover.

a- cross-section; b- cover overlay; c- canopy (Version I);
 d- canopy (Version II); e- shoe; f- peripheral frame.

on the edge of the membrane or individual hermetically sealed compartments are installed in order to achieve buoyancy. If the membrane has a welt, then it is reenforced with radial and circular ribs. This is called the pontoon type of construction. There is a 200 mm clearance between the pontoon and the storage tank wall. Because the storage tank wall and the pontoon deviate from true circles, in practice the clearance can vary \pm 80 mm. A seal on the pontoon makes the hermetic seal.

If the storage tank has no standardized cover (i.e. it is open) and the cover is a pontoon which floats on top of a filled reservoir, then such a storage tank is called a tank with a breather roof.

The pontoon can be made of metal or a gasoline resistant, non-metallic material, for example, metal on the periphery and a non-metallic membrane in the center.

Fig. 2.5 shows a 5000 m³ storage tank which has a pontoon. Storage tanks with capacities of 10,000 and 20,000 m³ have similarly structured pontoons.

The principal parts of a pontoon are: a metallic circular frame and a membrane which can be made either of rubberized fabric or metal. The membrane is attached to the circular frame by bolts and clamping strips. The method of sealing the space between the tank's wall and the breather roof or pontoon is very important.

The seal must make a hermetic seal at the gap; it must be stable in gasoline; work both in low and high air and product temperatures; be abrasion resistant; and must be safe in case of fire.

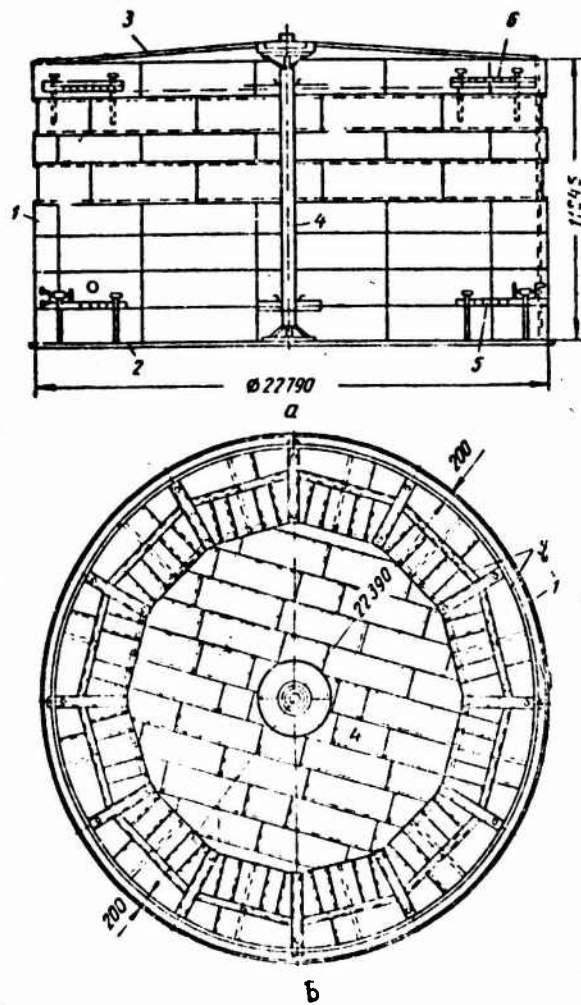

Fig. 2.5. A 5000 m³ storage tank with a metal pontoon and center post (Giprosnetsneft' design 1957).

a- cross-section; b- pontoon diagram; 1- tank wall; 2- bottom; 3- frame and panel cover; 4- central support; 5- pontoon in the low position; 6- pontoon in the high position.

In practice either hard (fig. 2.6) or soft (fig. 2.7) seals are used; they can be made from rubberized sheets of fabric or are solid. Basically, the hard (mechanical) types of sealers have the following features.

1. Sliding metallic members made into wide strips (up to 1000 mm) from flexible thin (1-1.5mm) zinc plated or galvanized steel or they can be separate pieces up to 2500 mm long and 1.5-3.0 mm thick. Pieces are connected by a coating of rubberized fabric.

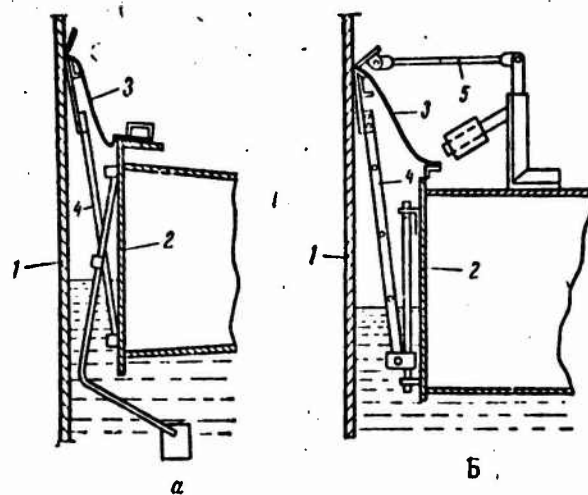

Fig. 2.6. Solid type of sealing systems from the State Pedagogical Institute, Proyecktstal'konstruktsiya.

a- for 16,000 m³ storage tanks (1963); b- for experimental 10,000 m³ storage tanks (1964); 1- tank wall; 2- breather roof; 3- membrane; 4- lever system; 5- clamping device.

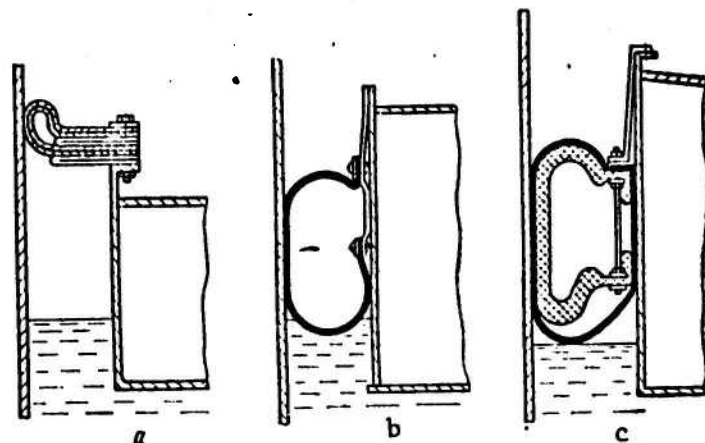

Fig. 2.7 Soft seals.

a- loop; b- a type of flexible, rubberized fabric sheath; c- same as in b but with a foamed polyurethane filler.

2. Lever suspension or clamping devices which press the sliding elements against the storage tank wall and hold them in a position fixed with respect to the breather roof.

Lever parts and articulated points are usually made of stainless or zinc plated steel.

3. A rubberized fabric membrane used in flexible seals to seal hermetically the space between the sliding elements and the breather roofs. The membrane can be installed directly over the petroleum product surface or level with the upper portion of the breather roof. In the latter case, a gas region is formed over the petroleum product and the membrane also acts like a protective baffle.

Holding the gas region over the petroleum products to a minimum by means of the membrane (or soft sealing sheaths) stops evaporation losses due to temperature changes and reduces the possibility of fire.

A standard thickness of asbestos or polycaprolactam covered on both sides with rubber is used to make the membrane. This material, apart from being chemically stable, is strong and flame resistant.

4. Protective baffles which protect the annular gap and sealing construction from atmospheric precipitation and from direct sunlight. Baffles are made from zinc plated, metal sheets and dense rubber or stiff plastic sheets and they are attached directly to the sliding parts or to the breather roof.

Soft seal construction features basically a sheath made of rubberized fabric and a packing made from porous and elastic plastic.

Abroad, sheaths are generally made of a special nylon fabric which has been coated with synthetic rubber of both sides.

Sheathing material must possess the following properties:

a) it must be dense enough so that the sheathing does not change as environment temperatures fluctuate from -40 to $+70^{\circ}\text{C}$ and it must wear well as it moves over the storage tank wall; clamping force and the coefficient of friction affect wear; under normal conditions the clamping force for an elastic, porous, synthetic material (foamed polyurethane) is 25-45 kg-f/m;

b) resistance to aging due to oxidation of the rubber in air;

c) resistance to reactions with petroleum product gases and with aromatic hydrocarbons; the chemical composition of the rubberized fabric depends on the amount of aromatic substances in the petroleum products;

d) an electrical conductive surface is needed to eliminate dangerous static electricity charges;

c) fire resistance

Porous plastics (foamed polyurethane) are widely used to make soft seals.

§ 4. Large Capacity Vertical Cylindrical Storage Tanks.

In designing large-scale storage tanks with the steels mentioned before, the plate thickness in the lower bands easily exceeds 14 mm and the rolled stock process quickly gets more complicated because such a large amount of plastic deformation is needed. Consequently, it's not possible to make storage tanks with capacities exceeding 20,000 m³ from rolled stock. On the other hand, industry needs these types.

In order to keep the capability of building large storage tanks without discarding industrial techniques, a series of building measures were proposed and the following are their main points:

1) to use high strength type steels S-45 and S-60 which have yield points of 45 and 60 kgf/mm² in the lower wall sections of storage tanks; then a single layer wall can be designed;

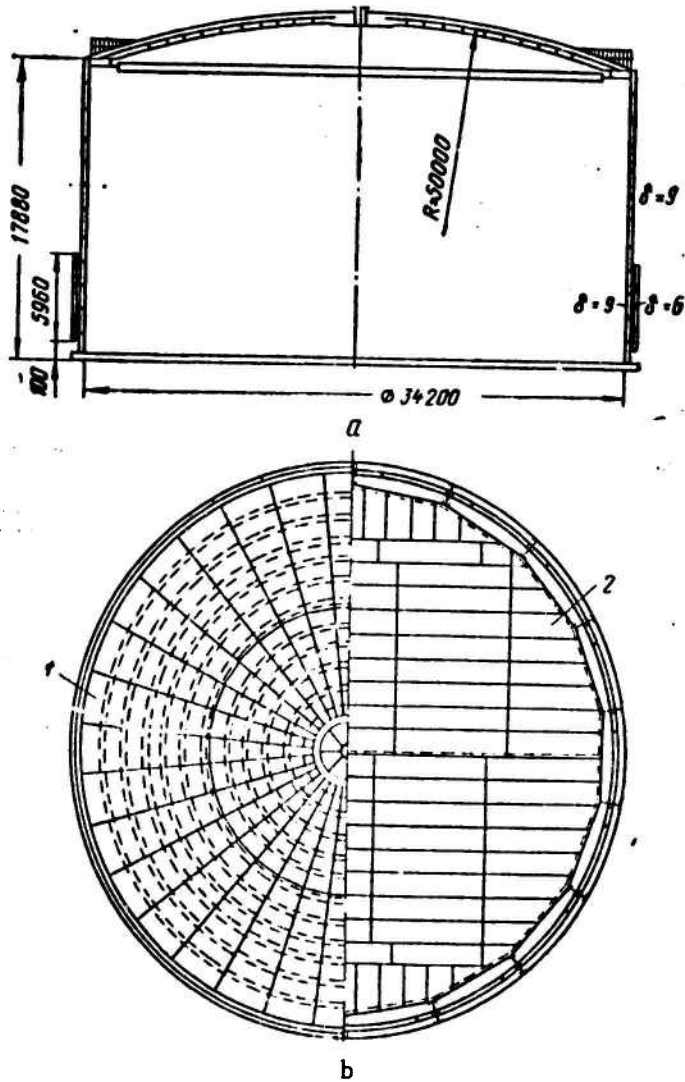

Fig. 2.8. Diagram of a 15,000 m³ experimental storage tank with double walls.

a- cross-section, b- cover plan (1) and bottom (2).

2) to design the lower wall sections with two layers so that a second wall can be added to a standard single layer wall (fig. 2.8);

3) to use pre-stressed walls or walls which have been re-enforced by high strength wire or bands; these can be wound with special winding machines such as the ones used to build reenforced concrete storage tanks;

4) in special cases large-scale storage tanks can be built using the plate method.

§ 5. Underground Trench Storage Tanks

Storage Tank Designation and Special Operating Features

Underground steel trench type storage tanks are usually intended to be used for long term storage of petroleum products.

The following considerations enter into designing such storage tanks:

1) making maximum use of the ground excavation as an integral part of construction;

2) to use dry soil so that metal instead of reenforced concrete bottoms can be built;

3) to use the most economical and widely used construction techniques for the cover load bearing elements and the retaining walls;

It's a widely followed practice, during design and construction, to use ground excavation and slopes as an integral part of construction.

The dry layers of soil protect metal from corrosion; it is easier to build; and far cheaper than waterproofing other types of designs.

When building trench type storage tanks, you must be careful that the water level is lower than the bottom of the storage tank by at least 1 to 2 m or else 6-8 m from the black datum marks, and that the area slopes in one direction to drain off surface and rainwaters. Each storage tank has a clay type lock-bridge which is at least 2 m wide and 10-15 cm thick and a drainage network if the soil is water absorbent.

Construction of Trench Type Storage Tanks

The storage tank metal liner is made from 4 mm thick sheet stock which is shipped to the area as rolled stock. A total of five side pieces 8.76 by 24.92 m and two end pieces 7.75 (9.46) by 25.06 m are made from killed or semi-killed steel types V St 3 sp or V St. 3 ps.

The metal liner runs along the bottom, the inclined surfaces of the excavations, and vertical wall surfaces.

A control-signal metal chute is placed at the center of the excavation just under the storage tank base.

Fig. 2.9 shows a 5000 m³ trench type storage tank.

A sand cushion 20 cm thick and an asphalt (waterproof) layer 10-20 cm thick are on the bottom and along the inclined sections.

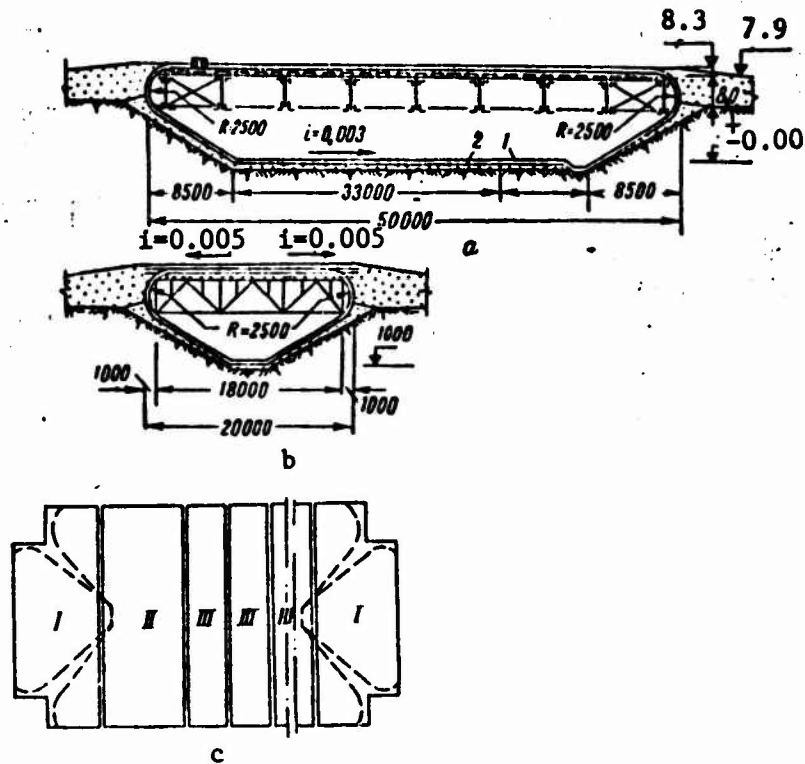

Fig. 2.9. A 5000 m³ trench type storage tank with walls formed into an envelope and steel, load bearing trusses for the cover.

a- longitudinal cross-section; b- transverse cross-section; c- liner development with a transverse cut-out of the section. I- end section, II, III - transverse sections. 1- 4 mm metal liner; 2- 100 mm sand-asphalt (waterproof) foundation.

The steel liner is bent at the sides (from the ground abutment side) to form a cylindrical curve and is welded on the inside to a diaphragm made from steel grid frames.

Temperature effects are compensated by bottom unevenness (there is no real compensation). The envelope is affixed to the end walls by assembly parts.

The design calls for the cover over the steel collar beams and frames to be made from vacuum formed reinforced concrete slabs - panels 4 or 6 m long and 22 cm wide. The seams between slabs are carefully cemented. A coating of cement to which sodium aluminate has been added and a 10 cm thick layer of clay are put over the cover for insulation.

The trench type storage tank is protected from corrosion by waterproofing the base and the slanting and the vertical sections of the liner; two layers of asphalt are put over the concrete wall; a clay barrier is put around the cover and a small clay drainage bridge is put on top. Besides this, the bottom of the storage tank is set at an angle ($i=0.003$) to drain precipitating water, acid or alkali to a lower level and a metal block supplies cathodic protection.

§ 6. Cylindrical, Steel Storage Tanks With Breather Roofs

The storage tank construction which we are studying (fig. 2.10) compensates for the evaporation loss of white petroleum products.

The storage tank roof acts like a bell; its edges move up and down on a special seal which has been assembled to the upper wall of the cylindrical storage tank.

When the gas volume increases because the temperature has increased (small scale breathing) or in pumping petroleum products into the tank (large scale breathing), the storage tank roof rises. It falls when the gas volume is reduced.

Roof travel in a 5000 m³ storage tank is 2520 mm.

Fig. 2.11 shows a diagram of the hydraulic seal in a breather roof. The seal is partly self adjusting and does not freeze at

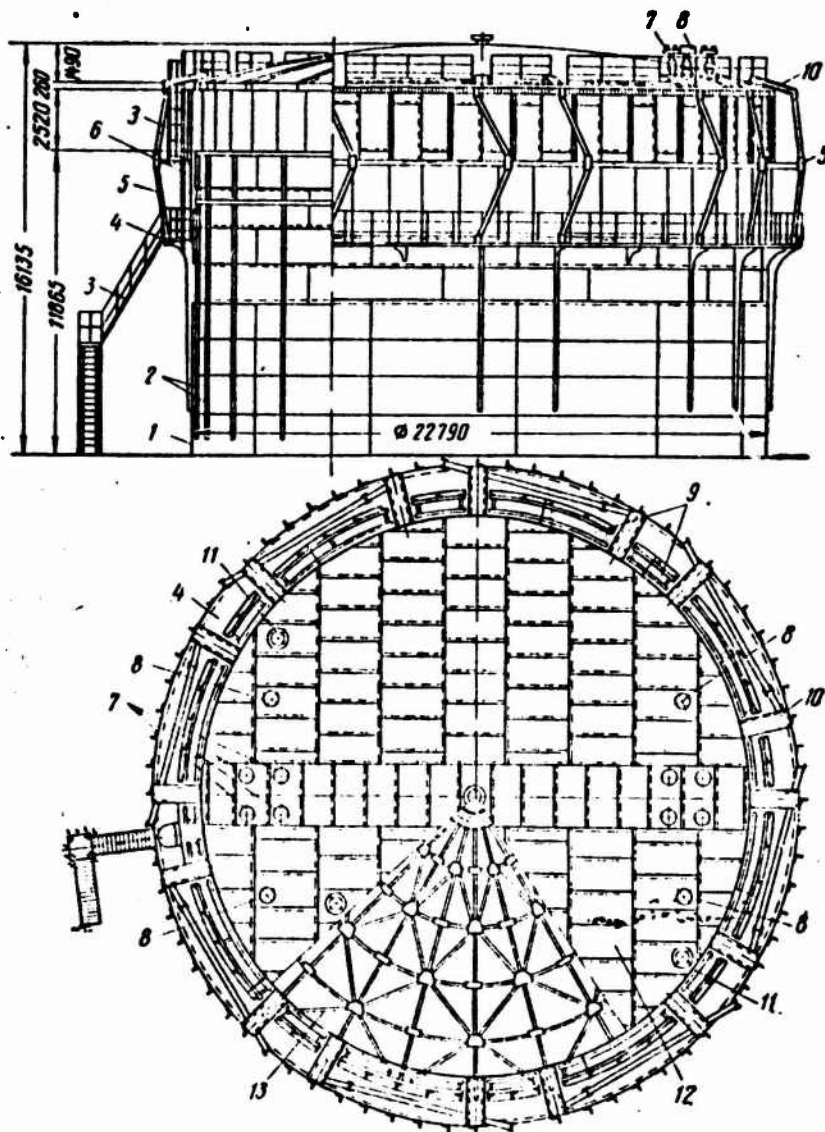

Fig. 2.10. A 5000 m³ steel cylindrical storage tank with a breather roof per Giprosnetspromstroj construction.

1- tank wall; 2- vertical stiffening ribs; 3- ladder; 4- balcony; 5- lever operated stabilizer; 6- hydraulic seal; 7- breather valves; 8- relief valve; 9- cargo area; 10- stabilizer bracket; 11- skylight; 12- roof covering; 13- rafters.

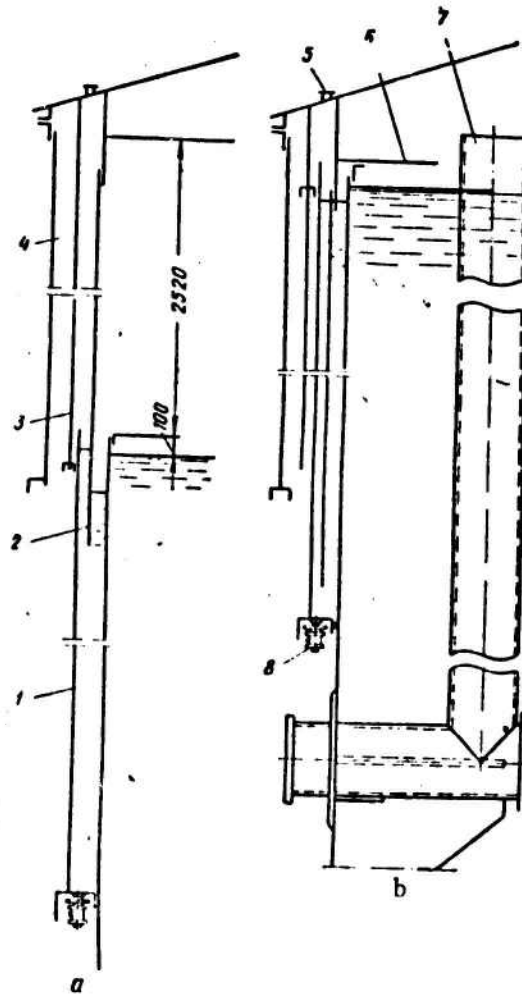

Fig. 2.11. Diagram of a hydraulic seal in a storage tank with a breather roof.

a- roof in the upper position; 2- seal wall; 3- travel stop; 4- atmospheric protective cap; 5- nozzle for filling the seal with lubricating oil; 6- ring stiffener; 7- breather tube; 8- freeze-proof drainage valve.

low fluid temperatures. The pressure under the bell type roof is the same as that in storage tanks which have standard type roofs, but an allowance is made for the gas envelope resistance because when a product is pumped into one or more tanks the excess vapor goes into a gas meter; and when the product is pumped out the vapor returns from the gas meter to the free space.

Storage tanks which have breather roofs are largely set within groups of regular, vertical storage tanks, and, therefore, their overall dimensions and bottom and wall construction is the same as other storage tanks.

5 7. Cylindrical, Vertical Storage Tank Beds and Foundations.

Storage tank foundations transfer product, construction, and snow loads to the bed.

Foundations can be either regular or elevated. Foundations 0.3-0.7 m high are regular while those more than 0.7 m are elevated. The height of the latter can be determined by finding out whether a gravity discharge of petroleum products from storage tanks set on them will be utilized. Elevated foundations can be made from fill, rock or reenforced concrete.

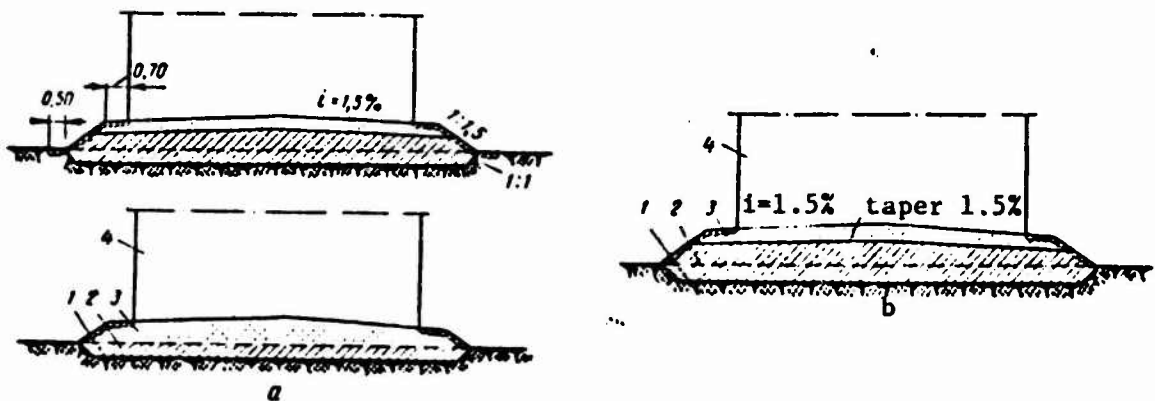

Fig. 2.12

Filled foundation for a vertical storage tank a- on sandy or sandy-loam soils; b- on cohesive soils (clay, loamy clay); 1- cut away view of the growth layer; 2- local earth; 3- sand cushion; 4- storage tank.

Filled foundations (fig. 2.12) are made in two parts: the lower section is native earth fill while the upper section is made from sand of average coarseness.

Foundations on slopes must depend on the nature of the site and are built on beds which either have only one level (fig. 2.13, a) or have several steps (fig. 2.13, b). Rocky, cohesive, stony, clay and very porous soils can be made into beds.

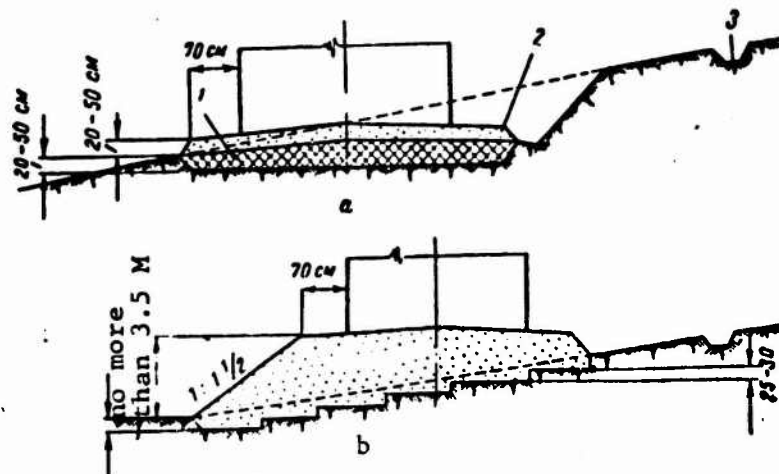

Fig. 2.13 Foundations on slopes

a- on one level with the bed; b- a step design bed; 1- soil fill; 2- sandy cushion; 3- upland ditch.

In places where soil is weak (load capacity is less than 2 kg-f/cm^2) and the layer is more than 6 m deep the soil can be compacted, depending on the specific tank design.

The different types of soils are classified by construction standards and rules. Black earth and podzolic soils may be used as beds for storage tanks with a capacity up to 300 m^3 inclusive.

The bed surface under the foundation fill is designed to be protected from surface water according to the sector's sub-soil surface location drawing design. The vegetation soil layer over the bed is removed entirely.

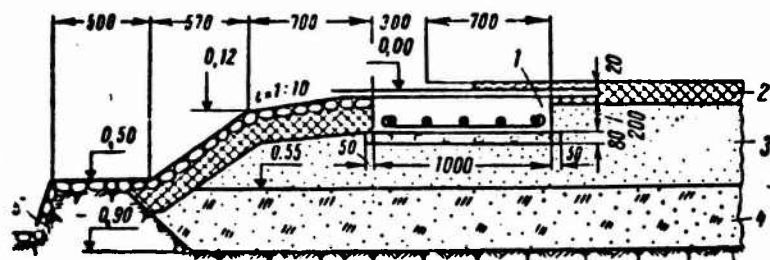

Fig. 2.14

A 10,000 m³ storage tank foundation which has a reenforced concrete ring under its wall.

1- concrete ring; 2- waterproof layer; 3- sand cushion; 4- ground fill; 5- drainage bridge.

Crushed rock, gravel, and sandy or clay type soils may be used for the ground fill. The latter can be used if their humidity does not exceed 15% at the time of deposit, while sandy-loam and clay-loam soils can have humidities up to 20%.

In beds made from clay soils, the first layer of the fill must be made from soils which will allow water to drain out from under the bed. Mud, peat, and vegetation growing soils may not be used for the ground fill. Sand cushions may be poured from sound with average coarseness. Fine sand may not be used.

In building the sand cushion and ground fill, the ground is covered in layers 15-20 cm thick and then carefully compacted by mechanical means. If the scope of work is not large, compacting (tamping) can be done with surface vibrators and tampers.

The surface of the cushion is inclined 1.7-2.3% from the center and the cushion is built with a 1:1.5 slope.

The insulating layer is set directly on the sand bed while the tank bottom is being built but is 80-100 mm below the red marker. The insulating layer is 80-100 mm thick (200 mm for very porous soils) and is made from sandy-loam soil which has been carefully mixed with a binding agent. Asphalt is the usual binding agent. There may be no acids or free sulphur in the binding agent.

Sandy-loam soil must have the following composition: sand with particles size 0.1-2 mm from 60 to 85%; fine sand and clay particles less than 0.1 mm, from 10 to 15%. Clay particles measuring less than 0.005 mm may be used as long as total percentage ranges from 1.5 to 5%. Grit with particle sizes from 2 to 20 mm may not exceed 25% of the soil total.

The amount of binding agent needed is usually found by trial and error, but usually makes up 8-10% of the mixture by volume. If the binding agent is not very plastic, it is first heated to 50-100⁰C.

The binding agent can be put on sandy beds evenly and without heating and then rolled in; and in the job is small, it can be worked over by vibrators or tampers.

Upland drain trenches are built to drain off water. Berms are set into the sand cushion at an 10% grade. The berms and drains in the bed are paved with rock to the point where assembly work starts and where the tank is tested.

If the intention is to store ethylated gasoline, the drain is made from concrete. Prefabricated, reenforced concrete, circular slabs are placed under walls of large capacity storage tanks.

Fig. 2.14 shows main construction features of a 10,000 m³ storage tank.

Chapter Three

STEEL STORAGE TANKS WHICH HAVE HIGHER GAS SPACE PRESSURES

§ 1. Current Status of Building Higher Pressure Storage Tanks

Higher pressure storage tanks have been designed to withstand an excess pressure of 1,000-7,000 mm of water (0.7 kg-f/cm^2). And except for the horizontal, cylindrical types, they are not widely used.

The following types of higher pressure storage tanks were developed during 1948-1970.

In 1944 the Giprosnetsneft' Institute designed a drop-shaped 2000 m³ tank (Fig. 3.1) which had a reinforcing ring. The tank was built at Groznyi in 1947. Four more similar tanks were designed in 1948 and built during 1951-1952. They were designed to withstand an excess pressure of 4,000 mm of water and a vacuum of 300 mm of water.

Later, G. M. Chichko suggested building a drop-shaped tank reinforced around the middle (Fig. 3.2); this had a number of advantages and better technical-economic features.

During 1955-1957, 700 and 2,000 m³ storage tanks (Fig. 3.3 and 3.4) with spherical-cylindrical roofs, called DISI, were developed at the Dnepropetrovsk engineering - construction institute (DISI) and subsequently were built. Later, similar tanks with 400 and 1,000 m³ capacities were built.

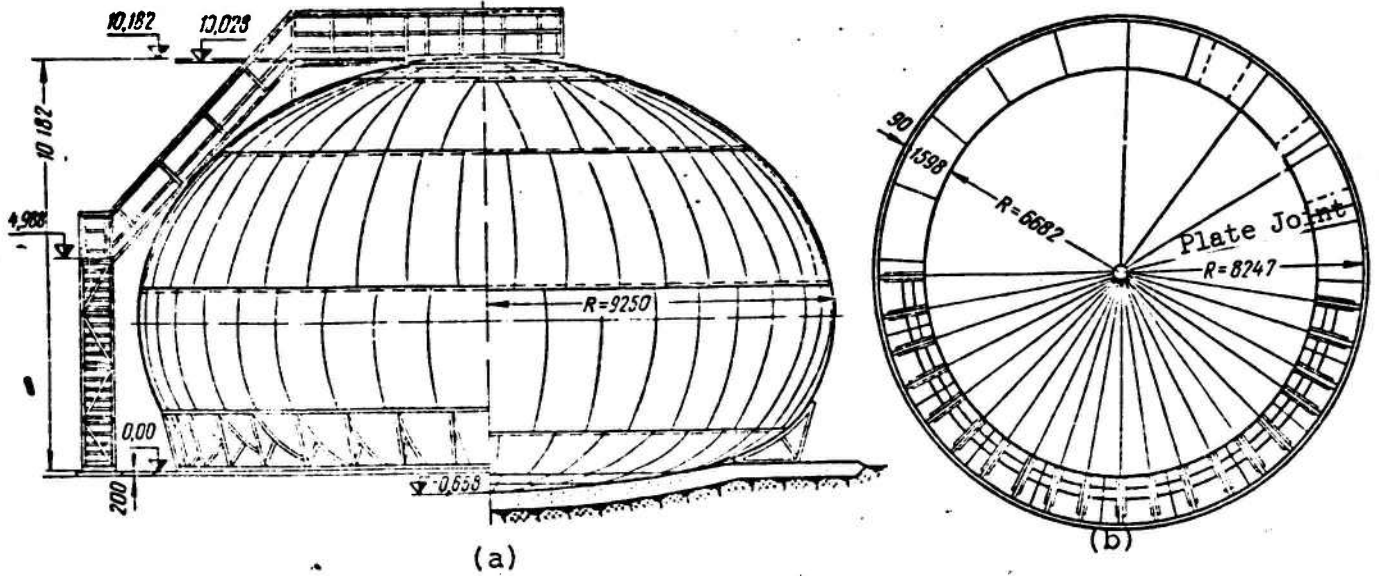

Fig. 3.1. A drop-shaped 2000 m³ storage tank with a reinforcing ring.

a- overall view and cross section; b- plan view of the reinforcing ring.

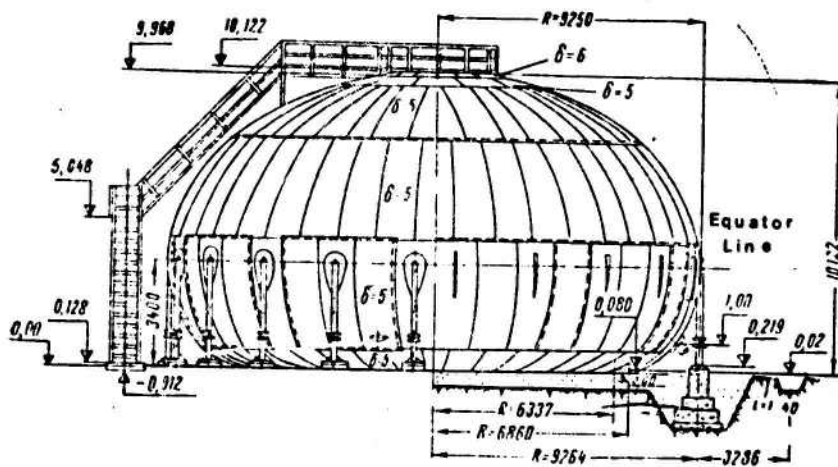

Fig. 3.2. A 2,000 m³ drop-shaped tank reinforced around the middle.

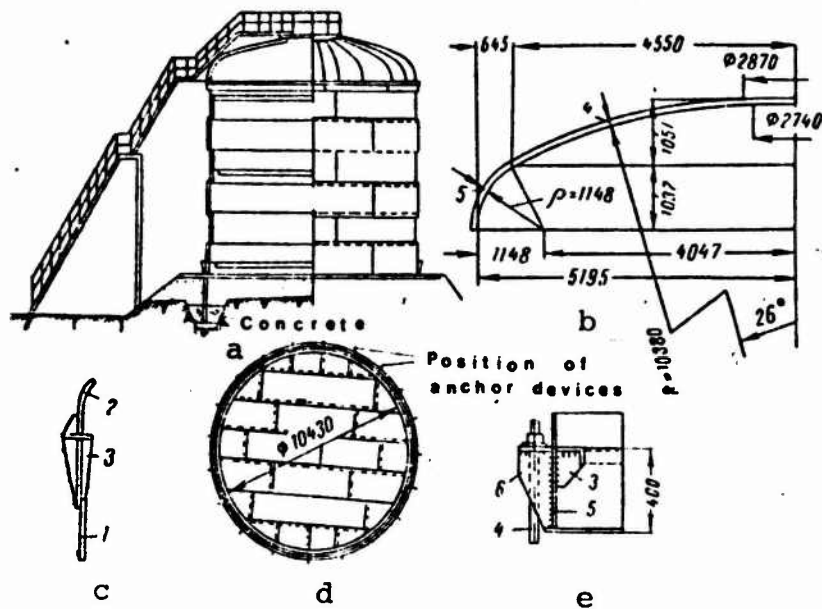

Fig. 3.3. A vertical, cylindrical 700 m³ storage tank with a spherical roof.

a- overall view; b- geometric layout; c- roof and wall contact point; d- bottom plan and distribution of anchoring devices; e- anchor section point of contact with wall.

1- upper belt; 2- roof covering; 3- stiffening rib; 4- anchor bolt; 5- tank wall; 6- anchor bracket

DISI tanks were designed to withstand an excess pressure of 1,300-2,000 mm of water and a vacuum of 50-150 mm of water. They were widely used.

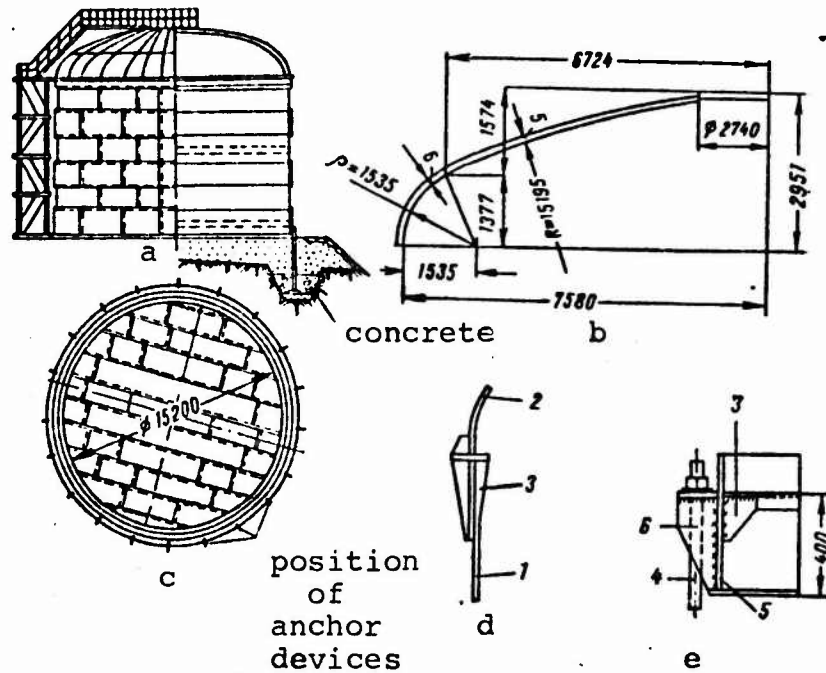

Fig. 3.4. A vertical, cylindrical 200 m³ storage tank with a spherical-cylindrical roof. Designations are the same as in Fig. 3.3.

The Proyektstal'konstruktsiya of the Central Scientific-Research Institute (T_sNII) has worked out the technical solution for building cylindrical, drop-shaped type tanks with capacities of 2,300; 3,400, 4,500; 5,500; 6,600, 7,700; 8,700; 9,800; 10,900; and 12,000 m³ as well as toroidal drop-shaped tanks with capacities of 20,000; 30,000; 40,000 and 50,000 m³. These tanks were designed to withstand an excess pressure as high as 7,000 mm of water. A cylindrical, drop-shaped, 7,700 m³ storage tank and a toroidal, drop-shaped tank are shown in fig. 3.5 and 3.6.

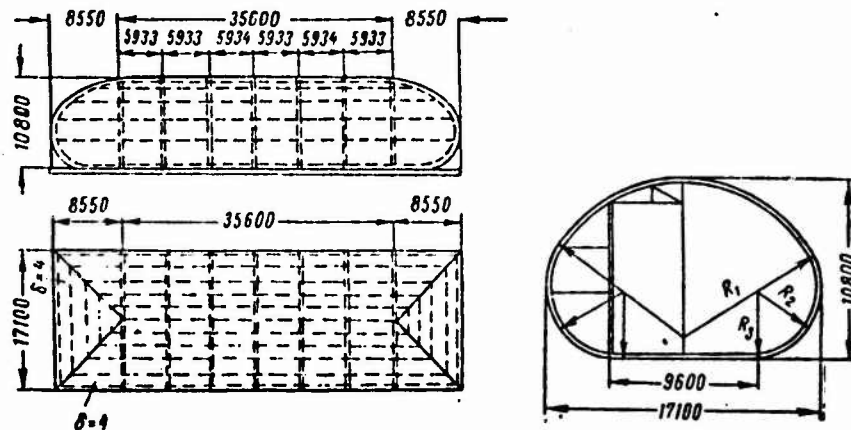

Fig. 3.5. A 7,700 m³ cylindrical, drop-shaped storage tank.

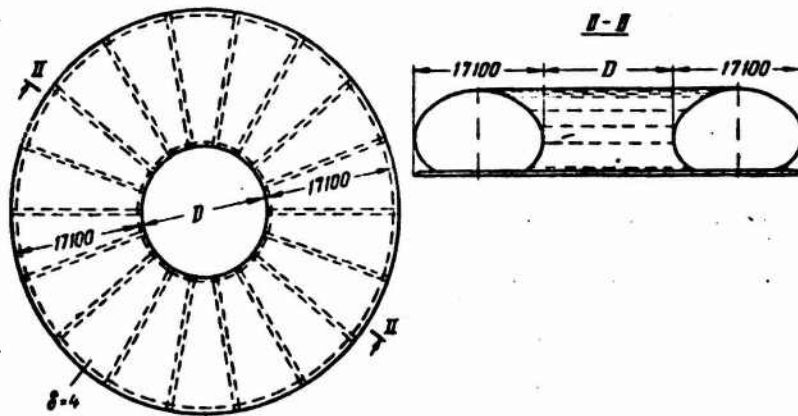

Fig. 3.6. Toroidal drop-shaped type storage tank.

Horizontal, cylindrical tanks with capacities from 3 to 75m³ and with different types of base construction (planar, conical, or spherical) were widely used in the USSR national economy.

At the suggestion of E. H. Lessig, horizontal tanks with cylindrical bottoms, resting on two points, in 50, 75 and 100 m³ sizes were developed and then produced over the period 1952-1957. These tanks can be used with excess pressures as high as 7,000 mm of water and a vacuum of 500 mm of water.

With regard to foreign construction techniques, the Gorton spheroids and other types of envelopes should be mentioned in addition to the Ribo type vertical, cylindrical storage tanks. Steel storage tanks for storing white oils at excess pressures up to 0.7 kg-f/cm² are relatively widespread abroad.

The smooth drop-shaped tanks are different from the multiplate steel tanks but they are still spheroids (fig. 3.7). The shape of the drop-shaped storage tank depends on petroleum product density and the working pressure.

Multitoroid drop-shaped storage tanks differ from the smooth types because they can change size, depending on conditions. Let us assume, for example, that the distance between the maximum and minimum fluid level marks in the tank is 12.5 m. If ground conditions at a particular place are such that it cannot carry the pressure from a 12.2 m column of fluid, then the tank height can be reduced by decreasing the radius of the lateral toroid. Thus, the tank diameter can be increased while the tank capacity remains unchanged.

The diameter and capacity of a storage tank which contains a given level of fluid can be increased also by adding toroids between the central spherical dome and the lateral toroid. Thus, in a Gorton type multitoroidal 12,700 m³ storage tank at an excess pressure of 0.7 kg-f/cm² there is an intermediate toroid (see fig. 3.7b) while in a 15,900 m³ tank there are two.

Engineer Ribo suggested constructing vertical, cylindrical, storage tanks which had a flat, reinforced concrete base and an elliptical dome (fig. 3.8). In this type of construction the reinforced concrete base slab is connected to the metal cylindrical wall or to a toroidal or elliptical cover. The reinforced concrete base takes up the vertical forces from the petroleum product vapors thrusting against the dome cover. When a tank is subject to an internal pressure, the forces, which are trying to lift the tank, are transmitted to the main wall or to reinforcing supports and are counterbalanced by the slab's resistance to bending due to the weight of the slab and the fluid in the tank.

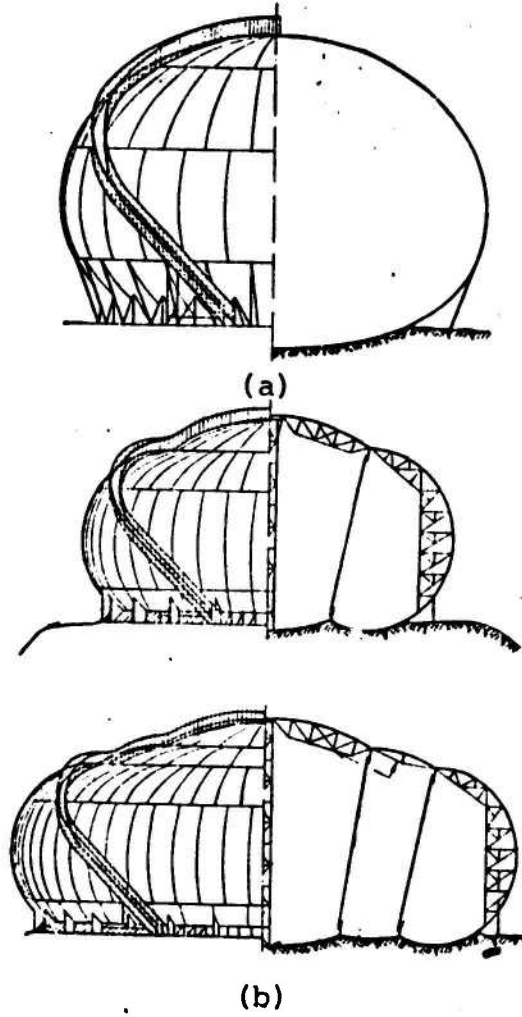

Fig. 3.7. A drop-shaped storage tank

a- simple spheroid; b- complex spheroids

If the tank is on rocky ground, tie bolts fastened deep in bore holes replace the slab.

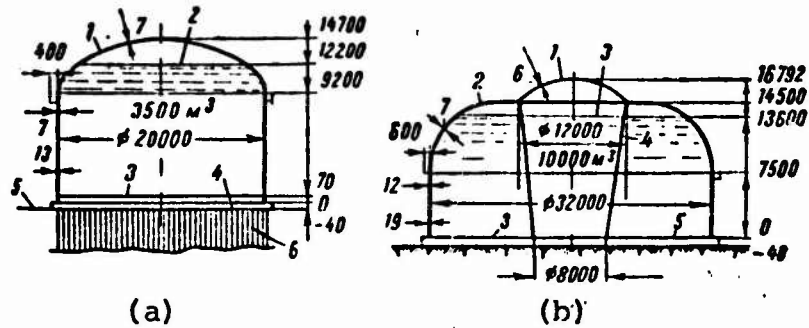

Fig. 3.8. Ribo type storage tank
a- 3,500 m³ capacity

1- elliptical dome; 2- gasoline; 3- water; 4- reenforced concrete slab; 5- ground; 6- piles

b- 10,000 m³ capacity

1- spherical dome; 2- one quarter of an ellipse; 3- gasoline; 4- steel pipes; 5- reenforced concrete slab.

§ 2. DISI Type Storage Tanks with Spherical-Cylindrical Covers and "Hybrid" Type Tanks with Toroidal-Spherical Covers.

DISI Type Storage Tanks

Vertical, cylindrical storage tanks with spherical-cylindrical covers, as developed by DISI*, are shown in Fig. 3.3 and 3.4.

* Creator of this type of construction is M. I. Ashkinazi

700 m³ storage tanks have the following design parameters: internal excess pressure is 1,650 mm of water; 30-50 mm of vacuum; the diameter is 10,430 mm; wall height is 9,000 mm; and the height of the spherical-cylindrical cover (from the reinforcing ring) is 2,083 mm.

The tank's wall is manufactured at the factory and is made from sheet stock in various thicknesses. In all there are six staggered circular layers of plates. The thickness of the first plate belt is 5 mm and 4 mm for the remaining.

The top auxiliary strip is 350 mm wide and is made from separate elements to which sections of the reinforcing ring are welded. Reinforcing rings are set up inside the wall to increase stability under vacuum: one ring is at the bottom layer, one is in the center of the fourth belt and another at the top. The reinforcing ring is made of 90x60x6 mm angles. Angles are bent on a "spine" and are welded to the wall to form a large flange which increases rigidity.

The bottom of the tank is a flat, 4 mm thick, lap welded, factory made piece. The lower section of the first belt is reinforced at the point where it is tied to the bottom with bolts anchored to the foundation - a counterweight, so that the bottom plates do not lift when the amount of fluid is small and the excess internal pressure is low.

Ordinarily, 20 bolts are used. They are distributed around the wall's perimeter at a distance of 1.5-1.8 m and have steel tie rods 30 mm in diameter which are secured to reinforced concrete slabs placed on the bottom of the circular foundation pit. The wall is connected to the brackets directly with the anchoring tie rods (Fig. 3.3 e).

The slab weight and the ground underneath it together with the tank's wall and cover weights form a counterweight which keeps the peripheral, circular area of the bottom down, when the internal excess pressure increases and there is little fluid in the storage tank.

The storage tank roof is spherical-cylindrical. It consists of a central ring and cylindrical, petal-like forms which look like two circles joined together; these smoothly connect to the wall to form what looks like a multifaceted roof surface up to the point where the surface turns (see Fig. 3.3 b,c). The diameter of the central ring is 2,740 mm and there are usually 24 petal forms. The larger radius of curvature of the cover's cylindrical elements is 10,380 mm and the smaller radius of curvature is 1,148 mm.

The central ring is lap welded to the petal roof and a stiffening ring made from 90x60x6 mm angle stock is set up inside. The petals are lap welded together. Each consists of two cylindrical elements forged into various radii. The butt joint of these elements occurs at the point where the small radius of curvature changes to the larger one (see fig. 3.3 b). Sheet thickness at the small radius is 5 mm and 4 mm at the large. Petal length is 4,692 mm and the width at the central part of the circle is 368 mm and 1,368 mm at the point where the cover joins the wall.

The roof petals are connected to the tank's wall by a horizontal plate 160 mm wide which provides the necessary stiffening.

Similar construction is used in 2,000 m³ storage tanks with spherical-cylindrical covers (see Fig. 3.4). It is designed to withstand an internal excess pressure of 1,650 mm of water and a vacuum of 30-50 mm of water; its diameter is 15,200 mm; wall height is 9,100 mm; and the height of the spherical cylindrical roof (from the upper reinforcing ring) is 2,951 mm.

Thickness of the first belt is 7 mm, the second is 6 mm, the third and fourth are 5 mm and the fifth and sixth are 4 mm. The usual number of anchor bolts is 20, their diameter is 42 mm, and the distance between them is about 2.4 m. The diameter of the roof's central ring is 3 m, it has 36 petals, the larger radius of curvature R is 15,195 mm and the smaller P is 1,535 mm.

This type of construction also has a support which is set up on the bottom in the center of the tank. The support is made from 150 mm diameter pipe and is as high as the wall plus the roof (about 12 m).

A telescopic shoe is set up at the bottom of the tank which allows the roof to move freely. The central support is rigidly connected to the center of the roof.

The central support is used during assembly, in making major repairs, and to inspect the roof at the upper wall belts from inside the tank. Fasteners are attached to it for installing a rotating platform to make this inspection.

"Hybrid" Type Storage Tanks

The lower belt internal diameter of "hybrid" 3,000 m³ storage tanks (Fig. 3.9) is 18,300 mm and the wall height is 10,375 mm. The tank's wall is made up of seven sections, and the thickness (from bottom to top) is 9,8,7,6,5,5 and 6 mm respectively.

So that the tank can be stable under vacuum conditions, the wall is reinforced with circular, stiffening ribs measuring 140 x 12 or 160 x 12 mm and located on the I, IV, VI and VIIth belt sections.

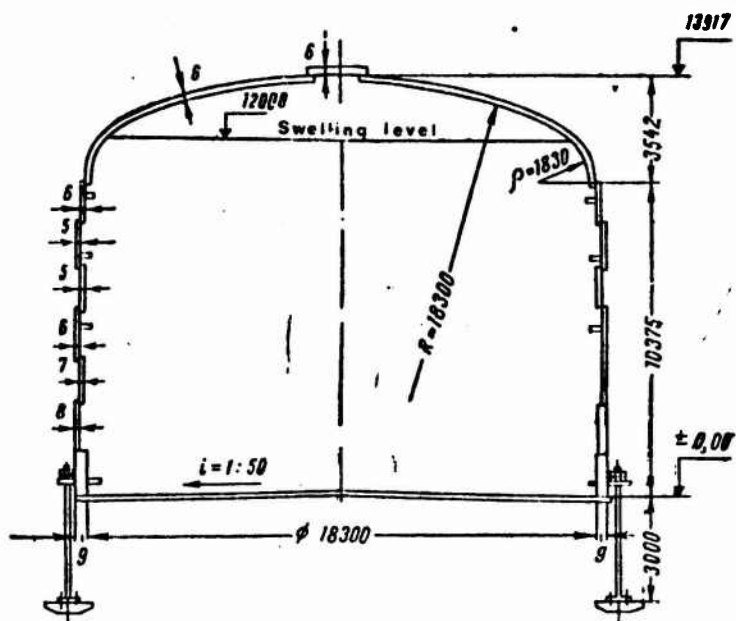

Fig. 3.9. "Hybrid" type 3,000 m³ storage tank

56 mm diameter anchor bolts (28 of them) are set around the lower belt to take up the vertical forces created in the wall because of excess pressure (up to 2,500 mm of water). The anchors are secured in reinforced concrete slabs placed 3 m deep in the foundation. By absorbing the upward forces the anchors keep the walls from lifting at the edges and tearing away from the foundation.

The central section of the base is 4 mm thick and the edges are 7 mm. The wall and base are assembled from rolled stock made at the factory.

The central section (radius of curvature R is 18,300 m) of the self-supporting toroidal-spherical roof is butt welded to the toroidal section (radius is P is 1,830 mm) which then is lap welded to

the tank's wall. Roof height is 3,542 mm. The circular seam which connects the toroidal and circular sections is left weak (welded only on the outside) to meet requirements of firefighting supervisory agencies. Roof sheets are 6 mm thick.

The tank roof is assembled from separate double curved petals manufactured at the factory storage tanks designed to withstand elevated pressures (up to 2,500 mm of water) require more steel than storage tanks of the same volume designed for low pressures (up to 200 mm of water).

If the construction requirements of a 3,000 m³ storage tank are weighed on the basis of 1 m³ of useful capacity, it only requires 19.2% of the weight of the corresponding low pressure type of storage tank.

§ 3. Storage Tanks Which Have A Spherical Roof and Base

A welded, vertical, storage tank with a spherical, flanged roof and base (Fig. 3.10) has been designed to withstand an excess pressure up to 3,000 mm of water and a vacuum of 150 mm of water. Because of the shape, the base of such a storage tank carries the excess and hydrostatic pressures and need not be anchored. The principle of maximum simplicity in form and economy of metal is basically followed in the design.

In this type of construction the vertical, cylindrical wall is like the wall in a low pressure storage tank, but the base and roof are spherical, and smooth, without reinforcing ribs, and like flanged hemispheres, welded to the wall. The basic tank parameters are as follows: diameter- 15,220 mm, wall height - 10,220 mm and roof and base radii of curvature - $R = 15,220$ and $p = 1,522$ mm respectively. Belt plate thicknesses are: I-7 mm, II and III - 6 mm, and the rest are 5 mm; sphere thickness is 4 mm and the flanged elements are 5 mm.

Despite the substantial cost as compared with vertical, cylindrical storage tanks, tanks which have spherical roofs and bases are very economical because they lose less petroleum products by evaporation.

The specific expenditure of steel to make 1 m^3 of tank capacity in a $2,300 \text{ m}^3$ tank comes to 16.9 kg/cm^3 , i.e., somewhat less than for a vertical, cylindrical storage tank of the same capacity.

The drawback to building these types of tanks is the difficulty in manufacturing the spherical bases and roofs.

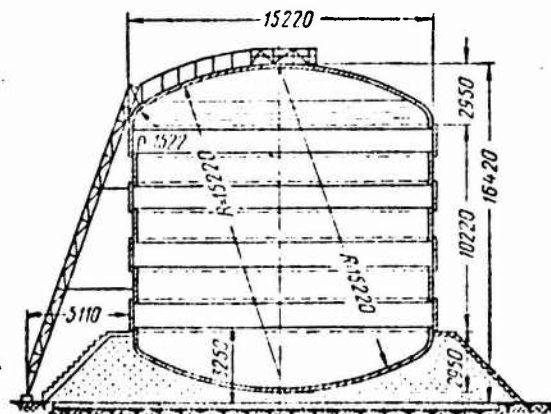

Fig. 3.10. A $2,300 \text{ m}^3$ storage tank with a spherical roof and base.

§ 4. Drop-shaped Storage Tanks

Axisymmetrical 2,000 m³ Drop-shaped Storage Tanks With A Support Ring (see Fig. 3.1).

The storage tank of the type we shall examine looks like a drop of liquid lying on a flat surface. When the excess pressure in the upper section of the tank acts on all points of the envelope, except for the section resting on the foundation, equal tension stresses are formed. For this reason, the envelope of a drop-shaped storage tank is called an equally distributed resistance envelope.

The tank's diameter at its equator is 18,500 mm and the overall height from the lowest point on the foundation to the highest point in the envelope is 10,850 mm. The thickness of the envelope above its equator is 5 mm and below it is 6 mm (by design it is expected to be 5 mm over its entire surface). Plate thickness in the support ring is 10 mm; the outside ring diameter is 16,494 mm; inside diameter is 13,364 mm; and the width of the ring is 1,565 mm.

The support ring has radial and annular stiffening ribs made from 8-10 mm sheet stock. There are usually 40 stiffening ribs. The support ring lattice and croze angle bar are made from 75x6 mm angle.

Forty reinforcing ribs made from 8 mm sheet stock are distributed inside the tank from the edge of the basin's base to the top of the reinforcing ring. Straps 8 mm thick, 1,200 mm long, and 100 mm wide are welded to the reinforcing ribs in the upper section; they are intended to stop any lack of stability when the ribs are compressed.

The storage tank has an internal framework of 20 vertical members made from No. 12 channel. Frame members are connected at six places with circular trusses made from 65x6 mm angle (except for the upper connections which are made from 100x8 mm angle). In the lower section the framework is secured by bolts (through the rib) to the internal stiffening ribs and the upper section is connected by bolts also to the central ring which is made from No. 12 channel and reinforced with circular straps made from 6-8 mm sheet stock.

The drop-shaped storage tank is made from open-hearth St. 3 rimming steel. The amount of metal needed for this type of construction is 64.7 T which includes; 41.00 T (63.4%) for the tank envelope; 8.30 T (12.8%) for the internal framework; 13.65 T (21.1%) for the support ring; and 1.75 T (2.7%) for the stair, handrail etc.

Axisymmetrical and Drop-shaped 2,000 m³ Storage Tanks With A Support Around The Middle (cf. Fig. 3.2)

This type of storage tank has a number of advantages as compared to the ring-supported drop-shaped storage tank, the most important of which is that the lower section of the envelope bears against a sandy cushion and the load from the petroleum products above it (below the middle) is transmitted through columns into the foundation, thereby relieving the load on the lower section of the envelope. In addition to this, in this type of construction there is no buildup of forces in the lower section, and as a result, no stress concentrations appear in storage tanks with support rings; therefore, envelope construction is simpler and there is no need for stiffening ribs inside the tank.

Twenty columns are set up in drop-shaped storage tanks which are supported around the middle, and they rest on a circular, concrete foundation. The supports are made of metal pipes and

are welded to the middle of the envelope by means of gusset plates. Anchor bolts secure the lower part of the column to the foundation. In this type of supporting construction the vertical forces which are formed in the envelope due to excess pressure are taken up by the mass of the envelope, the support, the foundation and the ground underneath.

The Proyektstal'konstruktsiya of T₂NII has designed horizontal, cylindrical storage tanks with various capacities. The height of these tanks (see Fig. 3.5) is 10,800 mm; the length of the cylindrical portion, depending on capacity is 6.9, 13.8, 21.7, 27.6, 35.5, 42.4, 49.3, 56.2 or 63.1 m; the thickness of sheet stock in all cases is 4 mm; and the maximum excess pressure ranges from 0.4 to 0.7 kg-f/cm². The tank ends are cylindrical surfaces and with the same shape as in the cylindrical section.

The storage tank envelope has an internal framework to stabilize it when partially filled. Supplementary stiffening ribs are placed at the point where the curvilinear housing envelope meets the base. External supports at the mid-point are recommended so as to strengthen the envelope.

§ 5. Horizontal, Cylindrical Storage Tanks with Planar and Three Dimensional Bases.

Various types of horizontal storage tanks and with different capacities are widely used within the national economy. They are used at all oil distribution centers, at state farms, at warehouses belonging to the various fuel departments, and at chemical wood technology and other branches of industry.

As a rule, white oils are stored in horizontal storage tanks at some excess pressure or vacuum.

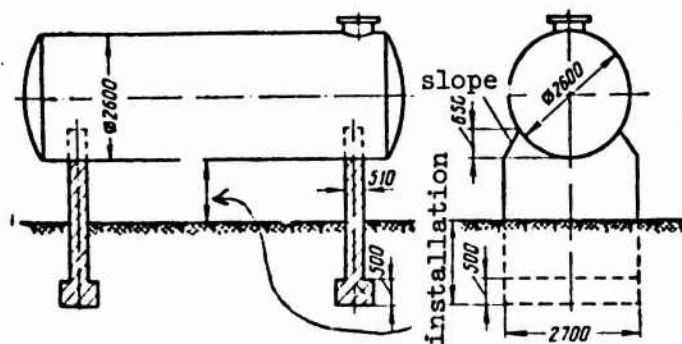

Fig. 3.11. Surface type, horizontal storage tank with two supports.

Investigations and experience have shown that it is best to use 3, 5 and 10 m³ tanks which have diameters less than 2.8 m and a planar, diaphragm base for storing petroleum products at excess pressures up to 0.4 kg-f/cm². Tanks with capacities of 25, 50 and 75 m³ and which have conical bases whose diameters range from 2.8 to 3.25 m are best for storing petroleum products under pressures up to 0.5 kg-f/cm². Horizontal storage tanks with cylindrical bases and whose capacities are 75, 100 and 150 m³ and which have a diameter of 3.25 m are more economical when working with pressures up to 0.7 kg-f/cm².

Horizontal storage tanks with cylindrical bases are made from sheet stock and the basic cylindrical envelope (housing) is connected at the bottom to two perpendicular cradles.

Fig. 3.11 shows a storage tank with a spherical base and two supports and fig. 3.12 shows a 75 m³ storage tank with planar and cylindrical bases.

By design, a storage tank with a nominal capacity of 100 m^3 and with a cylindrical base has the following parameters: length is $12,230 \text{ mm}$; inside diameter is $3,234 \text{ mm}$; sheet stock thickness is 4 mm . The base's radius of curvature and material thickness is the same as in the housing. The basic tank envelope is made up from six circular sections. The cylindrical bottom plates and the plates in each circular section are butt welded while the circular sections are lap welded to the end sections just as all other circular sections are, except for the tank's middle circular seam which is butt welded.

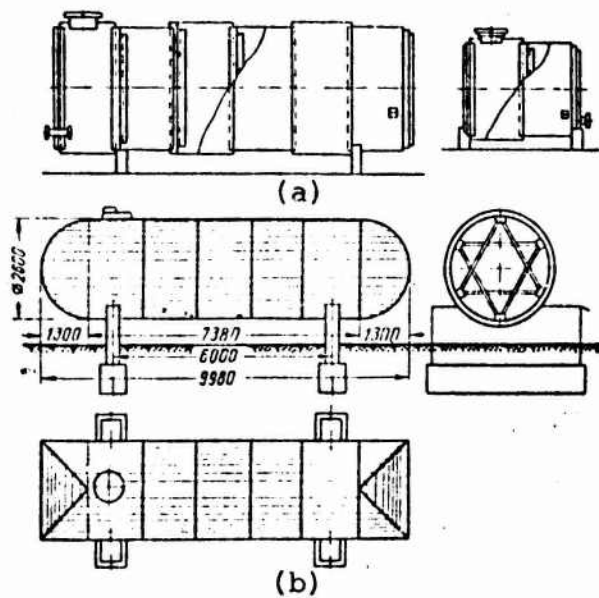

Fig. 3.12. Horizontal storage tanks.

a- with flat bases; b- with cylindrical bases (capacity is 50 m^3)

Two diaphragms made from two triangles and five intermediate stiffening rings which do not strengthen the rod type triangle are positioned inside the tank along the support planes. The stiffening rings are 1.8 m apart and are made from 75x50x5 angle.

The diaphragm support rings, formed from 120x80x8 angle, are forged so that the wide flange falls in the plane of the tank's cross section. The angle-cross struts used with the diaphragms are 100x75x8. The tank is placed on unit-construction upright supports.

Chapter Four

STATIC ANALYSIS OF STORAGE TANKS

§ 1. Loads Which Act On Load Bearing Storage Tank Members, and Design Coefficients

Load bearing storage tank members are designed for the following loads and combinations:

- a) the weight of the construction itself;
- b) hydrostatic loads due to the weight of the petroleum or petroleum products having a specific gravity of at least 0.9 T/m^3 ;
- c) weight of equipment;
- d) excess pressure;
- e) vacuum;
- f) snow load, a function of construction geography;
- g) wind load, also a function of the construction area.

Storage tanks are designed by the critical state method which takes into account the uniformity coefficient k , the load factor n , and operating conditions m .

The uniformity coefficient for steel which is characterized by property variations, is used to find the design resistance R : k is multiplied by the standard strength of steel R^H . Thus $k=0.85$ for carbon steels or $k=0.8$ for low alloy steels.

Values for the load factor and operating condition coefficients as set forth by SNiP II-V.3-62 are listed below.

- a) load factor coefficient n for various types of loads:

its own weight	1.1
equipment weight	1.2
hydrostatic pressure	1.1
excess pressure or vacuum	1.2
snow load	1.4
wind load	1.2

b) working condition coefficients m , used in designing storage tank sections:

storage tank walls	0.8
telescopic walls	0.9
junction of the tank wall and base	1.6
spherical and cylindrical gas tank envelopes of constant volume when designing by the momentless method	0.6
edge effect zones	1.7

c) working condition coefficients m in designing envelopes for stability

for the critical stresses	0.6
---------------------------	-----

d) working condition coefficients m for compression members in storage tank and gas tank domes and stiffening rings 0.9

§ 2. Basic Conditions for Designing Construction By Critical States.

In any given design, the construction must be viewed from its critical state. A post-critical construction state is one which ceases to satisfy operational requirements, i.e., either it loses its ability to resist external influences or it experiences unacceptable deformation or local damage.

Two critical states have been set up in accordance with SNIPII-V.3-62 for steel construction:

1) first, that state determined by load carrying capability (strength, stability and durability, as for example in construction projects which run cyclically);

2) secondly, that state as determined by excessive deformations (deflections and displacements); construction projects must satisfy this critical state or else their use may be limited because of deformations.

The first critical state can be expressed by the inequality
(4.1)

$$N \leq \Phi,$$

where N is the design force in the construction which is the sum of all acting design loads P in the worst case; and ϕ is the load-bearing capacity of the construction which is a function of the geometrical dimensions and material properties (yield point, tensile strength, ultimate tensile strength, elastic modulus, etc.).

The higher loads established by standards and which are permitted in normal construction usage are called standardized loads and are designated by the symbol P^N . The design load is the product of the standardized load and the load factor n (greater than unity) which takes into account load variation and the risk of the load exceeding that specified in the standard,

(4.2)

$$P = P^N n.$$

Forces (axial force N , bending moment M etc) are created as the result of design loads on the construction and their magnitudes are controlled by the strength of materials and construction mechanics.

The load carrying capacity of a material depends on its ultimate load strength, a function of its mechanical properties, and is designated by the standardized strength symbol R^N .

The standard tension, compression, and bending moment strengths for construction steels are equal to the lowest yield point σ_T ($R^N = \sigma_T$).

To account for the type of operations the construction will be exposed to, the coefficient of operating conditions m is introduced and where necessary this lowers the design stress σ . Then

$$\sigma \leq m k R^N. \quad (4.3)$$

Thus, after checking strength, the first design condition (4.1) takes the form

$$N \leq F R \quad \text{or} \quad M \leq W R, \quad (4.4)$$

where N and M are the design axial forces and bending moments resulting from the design loads (taking into account load factor coefficients n); F is the part's cross sectional area; and W is the section's moment of inertia.

When designing for strength, sections are selected and are then checked for stress levels due to the design forces so they never exceed the design strength of the material (keeping in mind the required coefficients which make provision for the operations required at the installations). Then the basic design formulas for checking strength take the form

$$\sigma = \frac{N}{F} \leq m k R \quad \text{or} \quad \sigma = \frac{M}{W} \leq m k R, \quad (4.5)$$

where σ is the design stress due to the design loads.

A second limiting condition in construction is evidence of excessive deformations (deflections). When finding the deflections, operational (standardized), and not design, loads are considered, i.e., load factors are not considered.

§ 3. Designing Walls in a Vertical, Cylindrical Storage Tank for Strength

The static design of a storage tank wall is carried out in the following order:

- 1) designing the walls using momentless theory, i.e., disregarding the bending moments which arise when the wall is connected to the base or in the circular wall seams (lap welded for all plate thicknesses or butt welded when there is a large difference);
- 2) a detailed design of the junction between the wall and base (keeping in mind the edge effect, see § 5);
- 3) a detailed design, taking into consideration the effect of the circular seams (and keeping in mind edge effect).

We shall examine the wall design using momentless theory.

The hydrostatic pressure resulting from fluid with a specific gravity γ is the main load when designing a low pressure storage tank wall for strength. This load on the wall only creates circular stresses. An excess pressure p_E (usually 200 mm of water or 0.02 kg-f/cm^2) can form in the vapor-air region of low pressure storage tanks. Fig. 4.1 shows a design diagram for a storage tank.

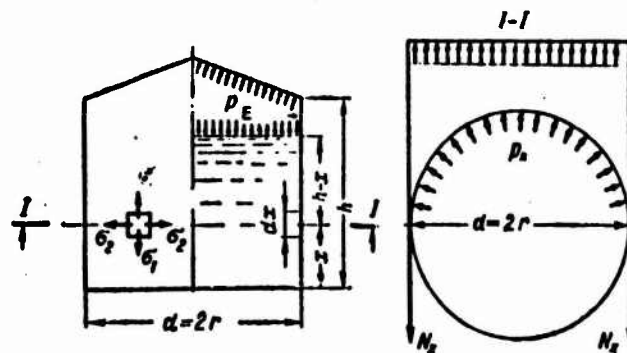

Fig. 4.1. Design diagram for a vertical cylindrical tank.

The hydrostatic pressure acts at a point on the wall x distance up from the base

(4.6)

$$p(x) = \gamma(h-x),$$

where γ is the fluid's specific gravity.

The total pressure against the tank's wall, including the excess pressure is

(4.7)

$$p_x = \gamma(h-x) + p_E$$

On One can use the well-known equation for envelopes of revolution which are subjected to an axisymmetrical load in a momentless condition to find the annular forces in the storage tank's wall:

(4.8)

$$\frac{N_1}{r_1} + \frac{N_2}{r_2} = p,$$

where N_1 and N_2 are, respectively, the vertical and circular forces; r_1 and r_2 are the vertical and circular radii of curvature, respectively.

In a cylindrical envelope $r_1 = \infty$; $N_1/r_1 = 0$; $N_2 = N$; $r_2 = r$. Then we have

$$N = pr, \quad (4.9)$$

or, taking into account p and the load factor:

$$N = [n_1\gamma(h-x) + n_2p_E]r. \quad (4.10)$$

The annular stress at a distance x up from the bottom is

(4.11)

$$\sigma = N/\delta.$$

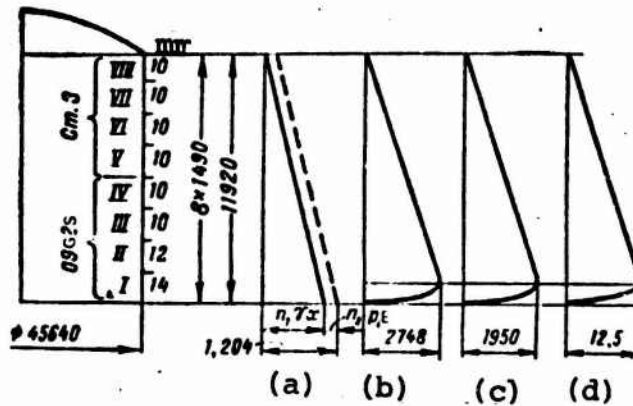

Fig. 4.2. Design diagram for a 20,000 m³ storage tank.

a- pressure curve; b- annular force curve; c- annular stress curve; d- radial load factor curve (deflections).

Then the final form of the formula for checking wall stability is

(4.12)

$$\sigma_s = \frac{[n_1 \gamma (h-x) + n_2 p_E] r}{\delta} \leq mR.$$

Fig. 4.2 shows the design diagram for a 20,000 m³ storage tank.

The following conditions exist in the wall due to the excess pressure acting on the cover and base (or on the fluid):

a) tension forces (independent of the roof's geometry)

$$\frac{\pi r^2 p_E}{2\pi r} = \frac{p_E r}{2};$$

b) longitudinal tension forces $\sigma_1 = pr_E/2\delta$ which are disregarded because they are insignificant.

Finally, we shall examine the wall's radial deflections which are caused by circular stresses σ_2 . If Δr represents an increment of the radius r , then, according to Hooke's law, we can write

$$\sigma_2 = E\epsilon = E(\Delta r/r), \quad (4.13)$$

where E is the material's modulus of elasticity; whence

$$\Delta r = \frac{\sigma_2 r}{E} = \frac{\gamma r^2 (h-x)}{E\delta}, \quad (4.14)$$

and with the excess pressure

$$\Delta r = \frac{\gamma r^2 (h-x) + pr^2}{E\delta}. \quad (4.15)$$

Note. When finding the increment Δr do not consider load factors.

§ 4. Designing Vertical, Cylindrical Storage Tank Walls for Stability

When verifying the wall stability of an ordinary storage tank with a fixed roof, a calculation must be made for the case when there is no fluid in the tank, and it is hermetically sealed or there is a theoretical vacuum inside.

The following are the design loads: weight of the roof and walls, snow load, equipment weight, and vacuum (there is no vacuum in a pontoon type tank).

Wall weight, circular area, and wind loading effects are used in calculating the stability of storage tanks which have floating roofs.

We shall examine a more typical case where a stability calculation is done for a common type of tank with a fixed roof. The calculation must be done with the following in mind:

- a) axial compression from the loads transmitted from the roof to the wall;
- b) a uniform, external, normal pressure caused by the vacuum condition inside the tank;
- c) combined effect of all these loads.

We shall examine all calculation conditions one after the other.

1. Designing a storage tank wall for axial compression. Wall stability can be checked by the following formula from SNiP II-V.3-62

$$\sigma_1 < \sigma_{01}, \quad (4.16)$$

where $\sigma_1 = qr/2\delta$ is the design axial compression caused by a uniformly distributed force q acting on the cover (including its own weight); and σ_{01} is the lower value of the vertical stress.

The critical stress depends on the relationship of the tank's wall radius r to the wall thickness δ . Therefore, the r/δ ratio for tanks holding petroleum or petroleum products, as a rule, is larger than 500, and the critical stress is found from the formula

$$\sigma_{01} = cE \frac{\delta}{r}, \quad (4.17)$$

where c is a coefficient whose value is selected from table 4.1.

Formula (4.17) is obtained by solving the non-linear problem having to do with the stability, under compression, of thin wall sections in a shell by using successive approximations.

Table 4.1

r/δ	c	r/δ	c
500	0,12 *	2000	0,055
750	0,10 *	2500	0,050
1000	0,08 *	3000	0,045
1500	0,07 *		

* c values have been taken from SNiF II-V.3-62 (the rest obtained are from experimental data).

2. Designing a tank wall for stability when a uniformly distributed force p is acting normal to the lateral surface. For purposes of simplicity, the wind load is given as a uniform value equal to half of the wind force. The calculation is made using the formula

$$\sigma_2 \leq \sigma_{02} \quad (4.18)$$

where $\sigma_2 = pr/\delta$ which is the calculated circular stress in the wall; and σ_{02} is the lower critical value of circular stress.

The value of the critical stress depends on the relationship of wall height l to its radius r and of its thickness to radius r .

Thus the l/r ratio usually satisfies the relationship where $0.5 \leq l/r \leq 10$ and the critical stress, in compliance with SNiP II-V.3-62, is found by the formula

$$\sigma_{03} = 0.55E \frac{r}{l} \left(\frac{\delta}{r} \right)^{1/2} = 0.55E \frac{r}{l} \cdot \frac{\delta}{r} \sqrt{\frac{r}{\delta}}. \quad (4.19)$$

Formula (4.19) is obtained by solving the non-linear problem having to do with the stability of thin wall cylindrical shells when subjected to a uniform, external pressure. A coefficient of 0.55 is used which is based on experimental data.

3. Designing the tank wall when subjected to combined axial compression and external, uniform pressure. In this case, stability is verified by the following formula which takes both conditions into account:

$$\frac{\sigma_1}{\sigma_{01}} + \frac{\sigma_2}{\sigma_{02}} \leq 1. \quad (4.20)$$

In this case the relation $1/(\sigma_1/\sigma_{01} + \sigma_2/\sigma_{02}) = k$ determines the shell's stability safety factor.

§ 5. Basic Conditions for Designing the Connection of the Tank Wall to the Bottom

We shall examine a vertical strip taken along the surface of the cylindrical envelope (Fig. 4.3). We shall take from this strip an element with height dx (Fig. 4.4) and we shall examine the equilibrium condition.

Summing the projection of all forces acting on the element onto the y axis (see Fig. 4.4) we get

$$(4.21)$$

$$p_x r d\phi dx - 2N_\phi \sin \frac{d\phi}{2} dx + r dQ d\phi = 0,$$

where $d\phi$ is the central angle corresponding to the arc element; N_ϕ is the circular force; and dQ is the transverse force increment.

Taking $\sin(d\phi/2) \approx d\phi/2$ because the angle is small, and dividing all terms of equation (4.21) by $rd\phi dx$, we get

$$(4.22)$$

$$\frac{dQ}{dx} - \frac{N_\phi}{r} + p_x = 0.$$

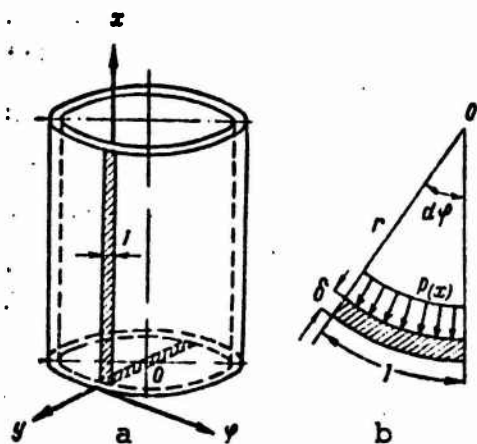

Fig. 4.3. Design diagram for a cylindrical shell.
a- coordinate system; b-length-wise shell element equal to l.

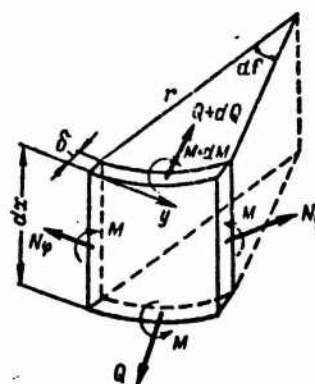

Fig. 4.4. Forces which act on the shell element.

We shall now express N_ϕ as a radial displacement w . The deformation of the element under investigation toward the y axis will be equal to

$$\epsilon = \frac{2\pi(r+w) - 2\pi r}{2\pi r} = \frac{w}{r}. \quad (4.23)$$

Therefore, according to Hooke's law, the circular stress will be

$$\sigma_{\varphi} = \epsilon E = \frac{E}{r} w, \quad (4.24)$$

whence we get the circular force

$$N_{\varphi} = \frac{E\delta}{r} w. \quad (4.25)$$

We shall express the transverse force Q as a third derivative of the deflection

$$Q = -D \frac{d^3 w}{dx^3}, \quad (4.26)$$

where D is the cylindrical stiffness in bending,

$$D = E\delta^3 / 12 (1 - \mu^2)$$

Substituting this relationship into equation (4.22) we get

$$D \frac{d^4 w}{dx^4} + \frac{E\delta}{r^2} w = \gamma(h-x) \quad (4.27)$$

or dividing both parts by D,

$$\frac{d^4 w}{dx^4} + \frac{E\delta}{r^2 D} w = \frac{\gamma(h-x)}{D} \quad (4.27a)$$

And setting

$$\frac{E\delta}{r^2 D} = 4\beta^4, \quad (4.28)$$

we finally get

$$\frac{d^4 w}{dx^4} + 4\beta^4 w = \frac{\gamma(h-x)}{D}, \quad (4.29)$$

where β is the coefficient of deformation,

$$\beta = \sqrt[4]{\frac{E\delta}{4r^3D}} = \frac{\sqrt[4]{3(1-\mu^2)}}{\sqrt{r\delta}}$$

here μ is Poisson's ratio.

The equation (4.29) is a differential equation which describes bending in a closed, circular, cylindrical shell subject to an axisymmetrical, hydrostatic load. The equation can also be derived as a special case of the general equations on shell theory. The usual solution of this equation takes the form

$$w = e^{\beta x} (A \cos \beta x + B \sin \beta x) + e^{-\beta x} (C \cos \beta x + E \sin \beta x) + \frac{\gamma}{k} (h-x), \quad (4.30)$$

where $k = E\delta/r^2$ and corresponds to the layer coefficient in solutions to beams on elastic supports.

§ 6. Designing the Connection of a Vertical Cylindrical Tank Wall to the Base.

A bending moment X_1 (M_0) and a transverse force X_2 (Q_0) are formed at a point where the wall joins the base in vertical, cylindrical storage tanks filled with fluid to the design level. The design diagram for the connection point is shown in fig. 4.5 and the basic system is shown in fig. 4.6.

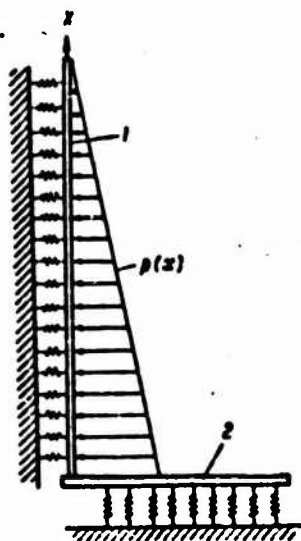

Fig. 4.5. Design diagram of connection of tank wall with base. 1 - tank wall; 2 - base.

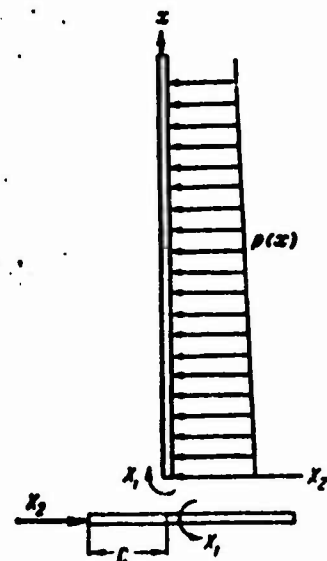

Fig. 4.6. Basic system. Forces arising in the connection of the tank wall with the base.

In order to solve for the extra unknowns X_1 and X_2 by the force method, we shall use canonical equations in the following form:

$$\left. \begin{aligned} \delta_{11}X_1 + \delta_{12}X_2 + \Delta_{1p} &= 0 \\ \delta_{21}X_1 + \delta_{22}X_2 + \Delta_{2p} &= 0 \end{aligned} \right\} \quad (4.31)$$

where δ_{11} , $\delta_{12} = \delta_{21}$, and δ_{22} are the unit displacements from $X_1 = 1$ and $X_2 = 1$; and Δ_{1p} and Δ_{2p} are the load elements which are functions of the external load. Thus, each unit displacement and the displacement due to the external load is made up of two components: 1) wall displacement, and 2) base displacement:

$$\begin{aligned} \delta_{11} &= \delta_{11}^w + \delta_{11}^b; & \delta_{12} &= \delta_{12}^w + \delta_{12}^b; \\ \delta_{21} &= \delta_{21}^w + \delta_{21}^b; & \delta_{22} &= \delta_{22}^w + \delta_{22}^b; \\ \Delta_{1p} &= \Delta_{1p}^w + \Delta_{1p}^b; & \Delta_{2p} &= \Delta_{2p}^w + \Delta_{2p}^b. \end{aligned}$$

If we consider the base to be absolutely rigid throughout, and remembering that there is no base deformation in the horizontal direction due to any moment, transverse force or external load, we get

$$\delta_{12}^b = \delta_{21}^b = \delta_{11}^b - \Delta_{1p}^b = 0.$$

Then the system of equations (4.31) takes on the final form of

$$\left. \begin{aligned} (\delta_{11}^w + \delta_{11}^b)X_1 + \delta_{12}^w X_2 + \Delta_{1p}^w + \Delta_{1p}^b &= 0 \\ \delta_{21}^w X_1 + \delta_{22}^w X_2 + \Delta_{2p}^w &= 0 \end{aligned} \right\} \quad (4.32)$$

All the unknown displacements which go into the system of equations (4.32) are found by solving for a semi-infinite beam

resting on an elastic support, so that for the wall case, we have a vertical strip of unitary width and a bed coefficient where $k_w = E \delta / r^2$, and for the base case, we have a strip of unitary width which rests on an artificial base having a bed coefficient k_b .

The extra unknowns X_1 and X_2 in the wall strip will be placed at the bottom while the point where the forces are applied on the bottom strip is a distance c away from the end. Therefore, unknown displacements are found by solving for beams resting on elastic foundations.

Finding Unit Displacements in Storage Tank Walls and Bases.

In examining the diagram for a semi-infinite beam loaded at one end with a concentrated force and a moment (fig. 4.7), we see that the deflection is zero at an infinite distance away from the point where the forces are applied. This condition can be met in equation (4.30), if the arbitrary constants A and B are set equal to zero. As a consequence, the equation for the deflected axis in a semi-infinite beam takes the form

$$w = e^{-\beta x} (C \cos \beta x + E \sin \beta x). \quad (4.33)$$

It is known from structural mechanics that the following relation can be established between deflection w , the angle of rotation ϕ , bending moment M , transverse force Q and loading intensity q where $D = \text{const.}$:

$$\left. \begin{aligned} \phi &= \frac{dw}{dx} \\ M &= -D \frac{d^2w}{dx^2} \\ Q &= -D \frac{d^3w}{dx^3} \\ q &= \frac{dQ}{dx} = -D \frac{d^4w}{dx^4} \end{aligned} \right\} \quad (4.34)$$

The arbitrary constants C and E in equation (4.33) can be found from equations (4.34) and the boundary conditions, so that when $X = 0$, the bending moment is equal to the specified moment M_0 , and the transverse force is located at the concentrated force P

(4.35)

$$\left. \begin{aligned} -Dw'' &= M_0 \\ Q &= -Dw''' - P \end{aligned} \right\}$$

Finding w'' and w''' from (4.33) and using boundary conditions (4.35) we find

(4.36)

$$C = \frac{2\beta}{k} (P - \beta M_0) \quad \text{and} \quad E = \frac{2\beta^2}{k} M_0,$$

where k is the bed coefficient.

Therefore, the deflection equation will take the form

(4.37)

$$w = \frac{2\beta}{k} e^{-\beta x} [P \cos \beta x - \beta M_0 (\cos \beta x - \sin \beta x)].$$

Subsequently differentiating equation (4.37), we find the angle of rotation, bending moments and transverse forces:

(4.38)

$$\varphi = w' = \frac{2\beta^2}{k} e^{-\beta x} [-P (\cos \beta x + \sin \beta x) + 2\beta M_0 \cos \beta x];$$

$$M = \frac{1}{\beta} e^{-\beta x} [-P \sin \beta x + \beta M_0 (\cos \beta x + \sin \beta x)]; \quad (4.39)$$

$$Q = e^{-\beta x} [P (\cos \beta x - \sin \beta x) + 2\beta M_0 \sin \beta x]. \quad (4.40)$$

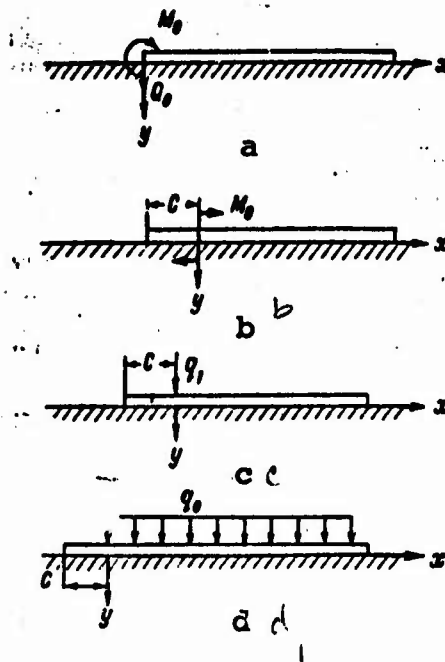

Fig. 4.7. Diagrams of semi-infinite beams resting on an elastic foundation and loaded as follows:

- a- by a concentrated force and a moment; b- by a concentrated moment at a distance c from the end; c- by a concentrated force at a distance c from the end; d- by a uniformly distributed load which starts at a distance c from the end of the beam.

Using the deflection and angle of rotation equations, all unit deflections which go into the system of canonical equations

(4.32) * can be determined. They are expressed in final form as
(4.41)

$$\left. \begin{aligned} \delta_{11}^w &= \frac{1}{\beta_w D_w}; & \delta_{11}^w = \delta_{11}^w &= \frac{1}{2\beta_w^3 D_w} \\ \delta_{22}^w &= \frac{1}{2\beta_w^3 D_w} \\ \Delta_{1p}^w &= \frac{\gamma}{k_w}; & \Delta_{2p}^w &= \frac{\gamma}{k_w} h \end{aligned} \right\}.$$

$$\delta_{11}^b = \frac{1}{\beta_b D_b} \cdot \frac{1 + \Psi_{\beta_b c}^2 + 2\theta_{\beta_b c}^2}{4}. \quad (4.42)$$

Base deflection due to external loads q , and q_0 (q_1 is a uniformly distributed load applied over one cm of wall perimeter and results from the weight of the roof and walls; q_0 is the uniformly distributed hydrostatic pressure on the base) is

(4.43)

$$\Delta_{1q_1}^b = \frac{q_1}{2\beta_b^3 D_b} \theta_{\beta_b c}^2;$$

$$\Delta_{1q_0}^b = -\frac{q_0 \beta_b}{2k_b} \cdot [1 - \Psi_{\beta_b c} \Psi_{\beta_b c} + 2\theta_{\beta_b c} \xi_{\beta_b c}];$$

* The derivation of the formulas for finding all deflections is given in the books: M. K. Safaryan "Steel Storage Tanks for Storing Petroleum Products", Moscow, Gostoptekhizdat, 1959; M. K. Safaryan, O. M. Ivantsov "Designing and Outfitting Steel Storage Tanks", Moscow, Gostoptekhizdat, 1961.

where

(4.44)

$$\left. \begin{aligned} \theta_{\beta x} &= e^{-\beta x} \cos \beta x; \quad \zeta_{\beta x} = e^{-\beta x} \sin \beta x \\ \varphi_{\beta x} &= e^{-\beta x} (\cos \beta x + \sin \beta x) = \theta_{\beta x} + \zeta_{\beta x} \\ \psi_{\beta x} &= e^{-\beta x} (\cos \beta x - \sin \beta x) = \theta_{\beta x} - \zeta_{\beta x} \end{aligned} \right\}.$$

Values for the derived functions are taken from tables which are listed in strength of materials literature.

§ 7. Designing Roofs for Vertical, Cylindrical Storage Tanks.

Vertical, cylindrical storage tank roofs carry a load due to their own weight as well as all equipment, snow and wind loads, and the load which results from excess pressure or vacuum. In some cases, special loads (due to the weight of thermal insulation or solar radiation shielding) also must be taken into account.

All vertical loads, including vacuum, are considered when designing roofs for strength, rigidity and stability.

We shall examine the following, typical, roof construction types: frame and panel (conical), spherical with stiffening ribs, and momentless.

1. Design of Frame and Panel (Conical) Roofs. As a rule, these types of roofs are inclined slightly (approximately 1/20) and are supported in the center with a central column. In designs where there is no central column the inclination is as follows: 1/10 for 300-700 m³ storage tanks; and 1/8 for 1000-5000 m³ tanks.

If there is a central support, the radial load bearing construction (beams) is installed according to a method where simple, double supporting beams rest on the tank's wall, and on the edge of the central post's crown or on the stressed triangle (if the crown dimensions are small) or on the load trapezoid. They serve the load bearing points for the load support beam and are symmetrically located between the trapezoidal axes at the beam.

The deflection limits for the roof beams (in the sections from the span), according to SNiPIV.3-62 should not exceed $l/250$ (1:250), where l is the beam span. Beam deflections must be small so that depressions are not formed in the roof where rainwater can collect and cause corrosion.

The roof is considered to act as a bracing system in those versions which have frame and panel roofs but no central support column. The angle of inclination is increased to reduce the amount of bracing. In such cases the design system is considered to be made up of two diametrically opposed inclined beams, which, with the stiffening ring, can be considered to be a triangular system with a conventional tie beam.

The stiffening ring acts as a conventional tie beam. Designing the tie beam is just like designing an arch.

2. Designing a Spherical Roof with Radial Stiffening Ribs. The following simplified design, which in practice gives satisfactory results, can be used for this type of roof. The roof, sensing the uniformly distributed, axisymmetrical load, is divided into separate, planar arches made from a pair of diametrically opposed ribs. Each arch bears against the wall via the internal stiffening ring which runs along the upper surface of the tank's wall. Thus, the support ring receives the thrust from all the arches and acts as a tie beam for all of them. Therefore, each arch can be

regarded as two dimensional, and double jointed, and containing a conventional tie beam. Fig. 4.8 has a diagram of an arch.

The cross-sectional area of the conventional tie beam is made in such a way that its elastic deformations are equal to the elastic deformations of the support ring and these are directed toward the diameter due to the horizontal reactions from all the ribs (fig. 4.9).

The increase in the circular ring diameter due to the thrust from each of the ribs is by Hooke's law

(4.45)

$$\Delta r = \frac{N_k \cdot 2r_1}{E} = \frac{N_k \cdot 2r_1}{EF_k} = \frac{nr_1}{\pi EF_k}$$

Where $N_k = (Hr_1 n / 2\pi r_1) = (ln / 2\pi)$ is the axial force in the ring caused by individual thrust forces; F_k is the cross-sectional area of the support ring; r is the radius of the support ring; and n is the number of ribs in the dome.

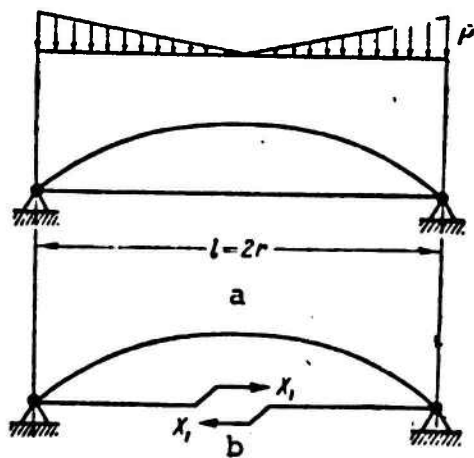

Fig. 4.8. Design diagram for a double hinged arch with a conventional tie beam.

a- design diagram; b- the basic system.

The increase in the length of the conventional tie beam due to a single thrust force from one arch is

(4.46)

$$\Delta_3 = \frac{1 \cdot 2r_1}{EF_3}$$

where F_3 is the cross sectional area of the conventional tie beam.

Equating tie beam elongation to the increase in the ring diameter, we get

(4.47)

$$\Delta_3 = \frac{1 \cdot 2r_1}{EF_3} = \frac{nr_1}{\pi EF_n}$$

The cross-sectional area of the tie beam can be found from this identity, so that

(4.48)

$$F_3 = \frac{2\pi F_n}{n}$$

Thus the design of a roof in this case reduces itself to the design of a double-hinged arch subject to a triangular load. The larger ordinate of the triangular loading diagram P is found by multiplying the equally distributed design load q which acts on the roof's projected area unit, by l , the larger arch along the wall between two adjacent ribs, i.e., $P = ql$.

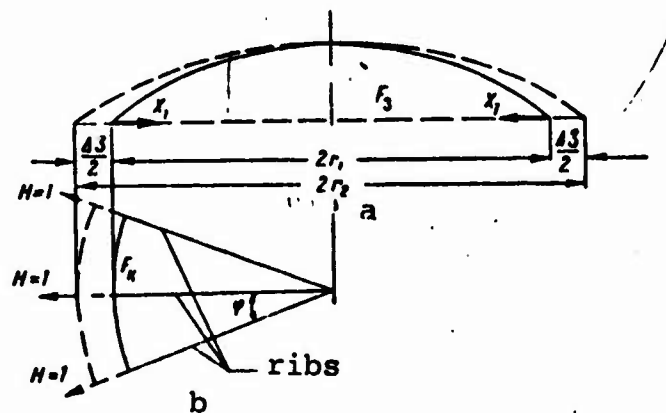

Fig. 4.9 An arch design diagram for finding the cross-section of a conventional tie beam.

a- design diagram; b- radial rib plan

Only vertical reactions are formed in the double hinged arch and tie beam, when a vertical load is applied, and the tie beam takes the thrust. Thus, the problem is statically indeterminate and has one unknown X (the thrust).

The basic system is considered to be an arch which has a cutaway section of a tie beam to which a unit force (thrust) $X_1=1$ is applied.

A bending moment M_1 , a longitudinal force N_1 and a transverse force Q_1 arise because of the longitudinal force $X_1=1$ acting on the arch and these are described by the formulas

(4.49)

$$M_1 = -y; \quad N_1 = -\cos \varphi; \quad Q_1 = -\sin \varphi,$$

but the tie beam only sees the force $H=1$. The minus sign in the formulas means that the moments are forcing the arch in a convex upward direction, the longitudinal forces are compressing it while the transverse forces acting in any cross-section are trying to turn both sections counterclockwise.

External loads create bending moments and they are expressed as an abscissa function x in the same way as for a straight beam. If we designate M_0 and Q_0 for the beam moments and transverse forces, respectively, for such a beam, we get

(4.50)

$$M_p = M_0; \quad N_p = -Q_0 \sin \varphi; \quad Q_p = Q_0 \cos \varphi,$$

where M_p , N_p and Q_p are the forces which act in the arch.

As for the tie beam, when an external load acts on it, M and Q are zero.

The basic unknown (the thrust) $X_1=M$ is found by solving the canonical equation

$$\delta_{11}X_1 + \Delta_{1P} = 0. \quad (4.51)$$

where δ_{11} is the mutual, horizontal displacement in the tie beam ends at the cutaway due to the force $X_1=1$; and Δ_{1P} is the mutual displacement at the same place due to the external load.

In the general case, δ_{11} and Δ_{1P} are found by considering what affect M_1 , N and Q have. However, N and Q can be disregarded because of their small displacements. Therefore, δ_{11} and Δ_{1P} are found only by using the unit force and external load moment diagrams. To simplify calculations, approximations replace exact integration and the problem is solved with a table of integrals. Thus, δ_{11} and Δ_{1P} are found from the formulas

$$EI\delta_{11} = \int y^2 d\varphi; \quad (4.52)$$

$$EI\Delta_{1P} = \int yM_0 d\varphi; \quad (4.53)$$

where I is the moment of inertia

The thrust is found by the formula

$$X_1 = H = -(\Delta_{1P}/\delta_{11}). \quad (4.54)$$

The equation for the axis of a circular arch is given in parametric form (the coordinate system starts at the left arch supports).

$$x = \frac{l}{2} - r \sin \varphi; \quad y = f - r(1 - \cos \varphi). \quad (4.55)$$

where l is the arch span, f is the leader, and r is the radius of curvature.

Formulas for the beam deflection moment and transverse force take the form

$$M_x^0 = \frac{Pl_x}{4} \left(1 - 2\frac{x}{l} + \frac{4}{3}\frac{x^2}{l^2} \right), \quad (4.56)$$

$$Q_x^0 = \frac{Pl}{4} \left(1 - 2\frac{x}{l} \right)^0. \quad (4.57)$$

The thrust force $H=X$ is found from

$$M_H = -\nu H; \quad N_H = -H \cos \varphi; \quad Q_H = H \sin \varphi. \quad (4.58)$$

The combined bending moment M curve and the longitudinal force N and the transverse force Q curves are found from the formulas

$$M = M_x^0 + M_H; \quad (4.59)$$

$$N = N_p + N_H; \quad (4.60)$$

$$Q = Q_x^0 + Q_H. \quad (4.61)$$

Since the normal force N and the bending moment M have been found, the problem now reduces itself to checking the arch cross-section for stability. First of all, the stability must be checked for the largest value of the normal force N , i.e., at the support,

where the bending moment is zero. The critical compressive force must be found for this condition. It can be found from the formula

$$N_{cr} = P_{cr} r = \frac{\pi^2 - \alpha^2}{\alpha^2} \cdot \frac{EI}{r} \quad (4.62)$$

or

$$N_{cr} = \frac{\pi^2 EI}{\mu_1^2 S^2} \quad (4.63)$$

where r is the arch's radius of curvature; α is the central angle (in radians) supporting half of the arch; S is the semi-arc length; and μ_1 is the design length coefficient which relates the arc curvature to the arch's pointer span.

In order to get stability the inequality $N_1 < N_{cr}$ must be maintained.

For a double hinged arch $\mu_1=1$ when $f/l=0.05$; $\mu_1=1.1$ when $f/l=0.2$; $\mu_1=1.2$ when $f/l=0.3$ and $\mu_1=1.3$ when $f/l=0.4$.

3. Designing a Momentless Roof. There is practically no bending moment in the flexible, axisymmetrically loaded momentless cover, and the roof acts like a momentless envelope. Therefore, the stress condition can be found with sufficient accuracy using momentless theory and taking into account the edge effects both at the point where the cover joins the stiffening ring and at the central support canopy.

Longitudinal forces T_1 and circular forces T_2 are created in the envelope and T_1 is significantly larger than T_2 .

So as to derive the equation for the curved, vertical cross-section of the roof (disregarding edge effects), we shall examine an element taken from the roof - a section where the central angle $\alpha = 1$ (fig. 4.10) and which has an equally distributed load q on the roof's surface. We shall assume that the tangent to the vertical when $x = R$ is horizontal, and we shall designate the vertical force of elongation of the element's edge, taken over a unit length of arc, as T_0 .

From the equation for equilibrium ($\Sigma M_0 = 0$) we get

$$\Sigma M_0 = T_0 R h - \omega q \frac{2}{3} R = 0, \quad (4.64)$$

where ω is the segment's area; and R is the arc's radius.

Furthermore, when $\alpha = 1$, the length of the arc segment is $l = R$, and the area $\omega = (1/2) \times l R = R^2/2$, we find from equation (4.64)

$$T_0 = \frac{q R^2}{3h}. \quad (4.65)$$

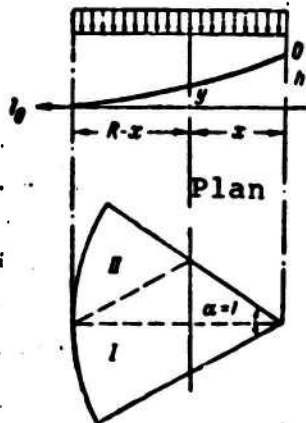

Fig. 4.10. Design diagram for a momentless roof.

The expression (4.65) is only a partial value for the longitudinal force when $x = R$.

Designating the vertical force in the section at x , taken over the unit length of the arc, by T_x , this may then be used to find the stress at any point in the storage tank's momentless roof.

Thus it has been assumed that the roof has no moment, i.e., it moves in the vertical direction only by stretching, and the fact that there is no moment present in any horizontal cross section can be described by the equation

(4.66)

$$T_0 R y - \frac{x(R-x)^2}{2} q - \frac{(R-x)^3}{3} q = 0,$$

where the second term describes the moment caused by the load in the I segment and where the third term is the moment caused by the load in the II segment (see Fig. 4.10).

Substituting the expression (4.65) for T_0 in the expression (4.66) we get the following equation for the curved, vertical cross-section

(4.67)

$$y = \frac{h}{2R^3} x^3 - \frac{3h}{2R} x + h.$$

We shall check equation (4.67) for the edge points in the roof. When $x = 0$, we get $y = h$, and when $x = R$, $y = 0$, which is the actual case. Equation (4.67) shows that a cubical parabola describes the vertical section in a roof without moments when carrying an equally distributed, axisymmetrical load q .

The formula for the vertical forces T_x can be obtained as follows, if two edge force values are considered.

1. When $x = R$ at the outside edge of the roof, the vertical force is described by the formula (4.65)

$$T_{x=R} = T_0 = \frac{qR^2}{3h}.$$

2. When $x = 0$, the vertical force must go to infinity because of the shape of the segment under examination, the area goes to zero and the stresses, therefore, in the relation T_x/F must go to infinity.

From the reasons given, the conclusion may be made that the formula for T_0 must be a special case of the general formula for T_x which has the form

$$T_x = \frac{qR^2}{3hx}. \quad (4.68)$$

Actually, when $x = R$ we get $qR^2/3h$; and when $x = 0, T_x = \infty$.

The derived equation allows finding the stresses at any point in a momentless roof and comparing these values with stresses found experimentally.

Calculating Forces in a Momentless Roof, Taking into Account the Initial Inclination of the Outside Contour

Experience in building and operating storage tanks has shown that a momentless roof is not very rigid and sags so much that it takes on a reverse curve at its center; this hampers the run-off of rainwater and causes severe corrosion in the metal. Because of this, that section of the roof joining the stiffening ring is set at an initial angle of $\phi = 5^\circ$ (Fig. 4.11). Then formula (4.65) for calculating the vertical forces at the edge of the

envelope, as determined by equilibrium conditions, takes the following form:

$$T_0 = \frac{qR^2}{3(h - R \tan \phi) \cos \phi} \quad (4.69)$$

When $Q = 1$

$$T_0 = \frac{R^2}{3(h - R \tan \phi) \cos \phi} \quad (4.70)$$

Using the fact that there are no moments in the roof, we can obtain the following, final expression for finding the vertical forces at any point in the roof when $q = 1$:

$$T_x = \frac{R^2}{3x(h - R \tan \phi)} \quad (4.71)$$

When $x = R$

$$T_0 = \frac{R^2}{3(h - R \tan \phi)} \quad (4.72)$$

Formula (4.72) differs from (4.70) by the $\cos \phi$ term which can be taken as unity for the case where $\phi = 5^\circ$. This is also confirmed by the fact that equation (4.71) fairly accurately tracks the change in vertical forces as a function of the distance x .

Since the edge of the roof has an initial angle of inclination, the pressure on the central post is larger than the combined external load.

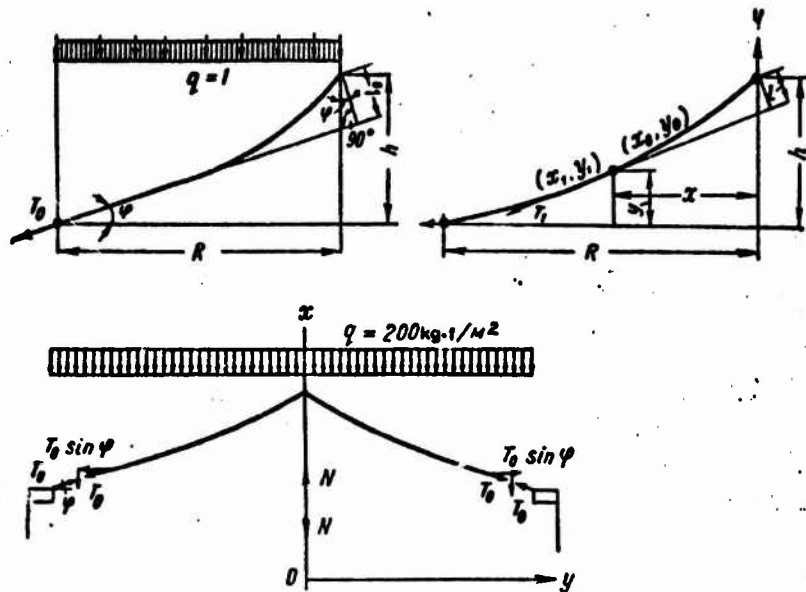

Fig. 4.11. Design diagrams for a momentless roof for a 5000 m³ storage tank, taking the initial edge inclination into account.

- a- roof and load diagram; b- design diagram for the roof;
c- design diagram for finding the forces in the central post

Actually, the sum of the projections of all the acting forces and loads onto the vertical axis is

$$\pi D T_0 \sin \varphi + \frac{4D^2}{4} q - N = 0, \quad (4.73)$$

whence

$$N = \frac{4D^2}{4} q + \pi D T_0 \sin \varphi, \quad (4.74)$$

where the second term represents additional forces caused by the initial inclination.

§ 8. On Designing Prestressed and Double Thickness Storage Tank Walls

The design of a prestressed or double thickness storage tank wall is done after the basic wall has been reinforced (with wire, bands or a second wall thickness). If the geometry of the basic wall is ideal and there are no spaces between the wall and the reinforcement, strength and stability can be computed using a work factor equal to one. However, in practice there are always spaces and the geometry is imperfect.

Therefore, the following approximate method is used for the calculation.

1. If the quality of workmanship is sufficiently good and the wire or second thickness are tightly fitted, then the construction will behave like a single wall with a normalized thickness.

2. The normalized thickness for a prestressed wall is found by the formula

$$\delta_{pr} = \delta_w + \delta_{re} \frac{R_{re}}{R_w}, \quad (4.75)$$

where δ_w , R_w , δ_{re} and R_{re} are the respective cross-sections and design material strengths for the wall, and wire or belt, so that the normalized thickness $\delta_{pr} = F_{re}/h_{re}$ (here F_{re} is the area of the wire, and h_{re} is the wire winding pitch).

3. The normalized thickness for a double thickness wall is $\delta_{pr} = (0.8 - 0.9) (\delta_1 + \delta_2)$.

§ 9. Design of Higher Pressure "Hybrid" and DISI Storage Tanks

We shall examine the design only of those load carrying elements of the storage tank which differ functionally from the elements in ordinary, low pressure storage tanks. These include anchoring devices which fasten the tank to the base; walls, which are designed to withstand higher vacuums than found in low pressure tanks and which have internal, horizontal stiffening rings, and roofs which are toroidal-spherical envelopes.

Design of Anchor Bolts

Anchor bolts are designed to withstand larger tension forces which are created by the excess pressure in the tank when there is little or no petroleum product present. If there is an excess of pressure p_E (kg-f/cm²) in the storage tank, and the cylinder radius is r (cm) and the number of bolts is n , then the force in the bolts (kg-f) can be found by the expression

$$n_1 p_E \pi r^2 = n_2 Q + n N_1, \quad (4.76)$$

where

$$N_1 = \frac{n_1 p_E \pi r^2 - n_2 Q}{n}, \quad (4.77)$$

where Q is the roof, wall, and part of the base weight (roughly 0.5-1 m wide) which is keeping the tank from lifting up; N_1 is the force applied to one bolt, and n_1 and n_2 are load factors.

Bolt cross-section is selected on the basis of this force and it also determines the hold-down capability (ground fill).

Designing Wall Stiffening Rings for Stability

Stiffening rings are installed to increase wall stability when the external, compression load (for example, when there is a vacuum in the tank) is sizeable and no provision has been made to stabilize the wall in accordance with formula (4.19).

The stiffening ring cross section is found by the following.

1. Using the actual wall thickness δ_{av} and formula (4.19), we find the load carried by the wall so that the critical stress σ_{02} is found first; then, using the formula $\sigma_2 = (pr/\delta_{av}) = \sigma_{02}$ we find the uniformly distributed critical load $P_{cr.w}$ which the wall sees. Here δ_{av} is the average thickness of the bands around the wall.

2. Compute the difference between the combined loads P_{vac} and $P_{cr.w}$ which the stiffening ring must support.

3. Find the number of stiffening rings n_k (or their pitch distance).

4. Find the critical load carried by one ring from the formula

$$P_{cr. ring} = \frac{3EI}{r^3} \quad (4.78)$$

5. Fulfill with the following inequality to maintain stability

$$n_k P_{cr. ring} > (P_{vac} - P_{cr.w}). \quad (4.79)$$

Designing Toroidal-Spherical Roofs for Strength and Stability

1. Designing the connection of the cylindrical envelope to the toroid to withstand an equally distributed internal pressure p_E (fig. 4.12).

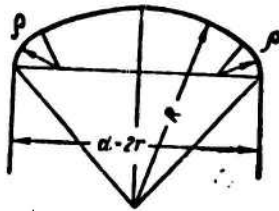

Fig. 4.12. Design diagram for a toroidal-spherical roof.

The forces which are created when the cylindrical roof is connected to the toroid is found by:

The bending moment

$$M_1 = \frac{p_E r^2}{8\beta^2 \rho} \zeta, \quad (4.80)$$

The longitudinal forces

$$N_1 = p_E r / 2, \quad (4.81)$$

The circular forces

$$N_2 = p_E r \left(1 - \frac{1}{4} \cdot \frac{r}{\rho} \left(0 - \frac{r}{2\rho} \right) \right). \quad (4.82)$$

The forces M_1 and N_1 at the transitional (toroidal) section are found by formulas (4.59) and (4.60) while the circular forces are found by formula

$$N_1 = P_E \cdot \left(1 - \frac{r}{2\rho} + \frac{1}{4} \cdot \frac{r}{\rho} \theta\right). \quad (4.83)$$

Geometric values are given in fig. 4.12 and the values for the functions ζ , θ , and β are given in § 6 of this chapter.

Maximum bending stresses are found by the formula

$$\sigma_{max} = \frac{GM_{1max}}{\delta^3} = \frac{6 \cdot 0.010 P_E r}{\beta^2 \rho \delta^3} = 0.145 \frac{P_E r}{\delta} \cdot \frac{r}{\rho}. \quad (4.84)$$

The critical external pressure for the toroidal section is given by the formula

$$(4.85)$$

$$\psi = \frac{k\delta}{\rho} \cdot \frac{\sqrt{2 + (1 - \mu^2) k^2}}{2\sqrt{3} \left(1 + \frac{k^2}{4}\right)},$$

where $k = \rho/r$.

2. Designing the Spherical Section of the Toroidal-Spherical Roof. The spherical section of the roof is designed to be stable under the combined effects of vacuum, snow load and the roof weight (P_{tot}).

The compressive stresses which result from the combined load P_{tot} is

$$\sigma_1 = \frac{P_{tot} r_c \psi}{2\delta}; \quad (4.86)$$

the critical stress is

$$\sigma_{01} = cE \frac{\delta}{r_{01}}$$

and the stability criterion is

$$\sigma_1 < \sigma_{01}$$

§ 10. Designing Axisymmetrical Drop-shaped Envelopes

Drop-shaped storage tanks are used to store petroleum products under an excess pressure of 0.3 - 0.4 kg-f/cm².

If the excess pressure can be conveniently replaced by a column of stored product with a height $h = p_E/\gamma$ (fig. 4.13), then the combined pressure (the main design load), including the excess pressure, can be expressed by the formula

(4.87)

$$p = \gamma(h + y),$$

where y is the vertical distance from the highest fluid level to the point under investigation on the envelope surface.

When using momentless theory (4.8) for design, the equilibrium condition for the envelope element takes the form

$$\frac{N_1}{r_1} + \frac{N_2}{r_2} = p = \gamma(h + y).$$

Uniform strength serves as the basis for designing envelopes for axisymmetrical, drop-shaped storage tanks, i.e., it is assumed that the geometrical shape of the envelope has been selected in a way that the tensile stresses are equal and constant when subjected to a basic design load in the vertical and circular directions, i.e., $N_1 = N_2 = N = \text{const.}$

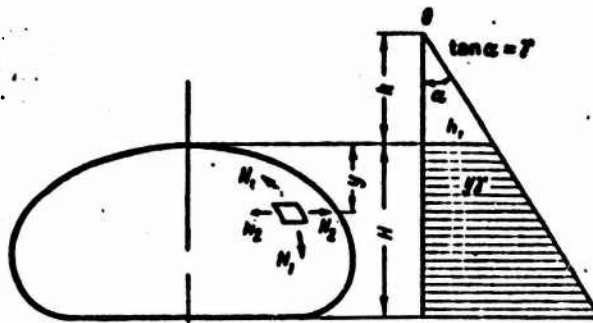

Fig. 4.13. Design diagram for a drop-shaped envelope.

We shall now find the forces which arise in a drop-shaped storage tank envelope which has a support ring due to a uniform excess pressure. The uniform pressure in axisymmetrical envelopes, including drop-shaped types, creates a vertical force

$$N_1 = \frac{P_E r_2}{2}, \quad (4.88)$$

i.e., the vertical force follows the law of variation of radius of curvature r_2 . Then, on the basis of equation (4.8) the formula for ring forces may be written in the form

$$N_2 = P_E r_2 \left(1 - \frac{r_2}{2r_1}\right). \quad (4.89)$$

Fig. 4.14a shows the vertical and circular force diagrams due to uniform pressure.

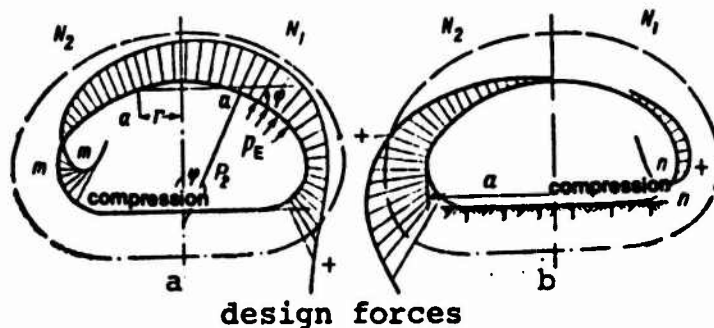

Fig. 4.14. Diagrams of vertical forces N_1 and ring forces N_2 in a drop-shaped envelope with a support ring.

At the peak of the envelope, where $r_1 = r_2 = r_0$, the vertical and circular forces are equal and are described by the relation

$$N_1 = N_2 = N = \frac{P_E r_0}{2}, \quad (4.90)$$

i.e., at the peak of the drop-shaped envelope the vertical and circular forces take on the same values as in a spherical envelope.

The hydrostatic pressure is zero at the envelope's peak; therefore, any vertical and circular forces are due to the excess pressure which can be found by formula (4.90).

Thus, equal vertical and circular forces will be present at all points in the envelope because of the basic design load which includes excess and hydrostatic pressures.

Therefore, the forces described by formulas (4.88) and (4.89) must be subtracted from equation (4.90) in order to get the formula for the vertical and circular forces due only to the hydrostatic pressure. Then we get

$$N_1 = \frac{\gamma h \epsilon}{2} (r_0 - r_1), \quad (4.91)$$

$$N_2 = \gamma h \epsilon \left[\frac{r_0}{2} - r_2 \left(1 - \frac{r_2}{2r_1} \right) \right]. \quad (4.92)$$

The force diagrams N_1 and N_2 due to hydrostatic pressure are shown in fig. 4.14b. The dashed line shows the curve for the design (total) load.

The following formulas were obtained for a section below the midpoint in drop-shaped envelopes which have G. M. Chichko type supports around the middle (similar forces above the midpoint were derived earlier):

$$N_1 = \frac{r_1^2 - r_b^2}{2/\sin \phi} \rho \epsilon. \quad (4.93)$$

where r is the abscissa of the point under consideration; r_b is the radius of the base's flat section; and ϕ is the angle subtended by the vertical and radius - vector.

On the curve where $r_2 = a$, the vertical forces are

$$N_{3c} = -\frac{a^2 - r_b^2}{2a} p_E \quad (4.94)$$

The formula for the circular force can be obtained from expression (4.8) by setting it equal to N_1 . We then get

$$N_1 = p_E r_1 \left(1 + \frac{r^2 - r_b^2}{2a} \cdot \frac{1}{r_1} \right); \quad (4.95)$$

and on the curve

$$N_{3c} = p_E a \left(1 - \frac{a^2 - r_b^2}{2a} \cdot \frac{1}{r_{1c}} \right);$$

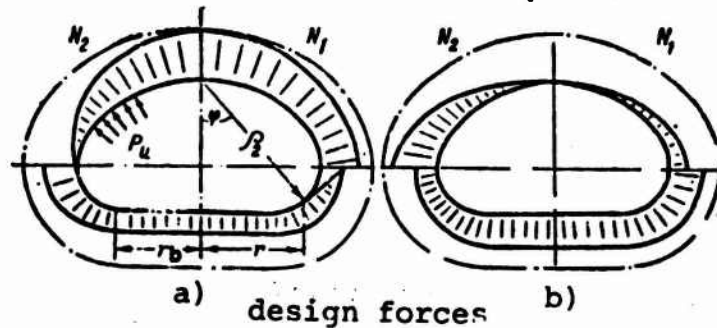

Fig. 4.15. Curves for the vertical forces N_1 and circular forces N_2 in a drop-shaped envelope along with a midpoint force diagram.

a- subjected to excess pressure; b- subjected to hydrostatic pressure.

But since $r_{1c} = (b^2/a)$, then

$$N_{3c} = p_E a \left(1 - \frac{a^2 - r_b^2}{2b^2} \right). \quad (4.96)$$

Forces caused by hydrostatic pressure are found in the same way as the forces in a storage tank with a support ring. Fig. 4.15 contains the force diagrams.

§ 11. Designing Horizontal, Cylindrical Storage Tanks and Various Types of Bases.

Wall Design

Let us take a storage tank which has a radius r in the cylindrical section, a wall thickness δ and an excess pressure p_E (fig. 4.16). Vertical stresses σ_1 and ring stresses σ_2 are formed in the wall because of the latter.

We shall section the tank along I - I and we shall examine the equilibrium condition of one section (the right, for example). Irrespective of its shape (flat, conical, or spherical), the tank's base sees a combined load Q which is the product of p_E and the area projection of the wall's section (a circle), i.e., $Q = p_E \pi r^2$. This load is taken up by the wall's cross-section and the area where $F = 2\pi r\delta$.

Thus, the vertical load carried by a unit length of the periphery, is

$$P_1 = \frac{Q}{2\pi r} = \frac{p_E \pi r^2}{2\pi r} = \frac{p_E r}{2}, \quad (4.97)$$

and the corresponding stress is

$$\sigma_1 = \frac{P_1}{\delta} = \frac{p_E r}{2\delta}. \quad (4.98)$$

The circular forces P_2 and stresses σ_2 can be found by inspecting the section II-II while in equilibrium. Removing the lower section, for example, and designating the circular forces by P_2 , we get $2P_2 = p_E \cdot 2r$ ($2r$ is the arc's projection), whence

$$P_2 = p_E r \quad (4.99)$$

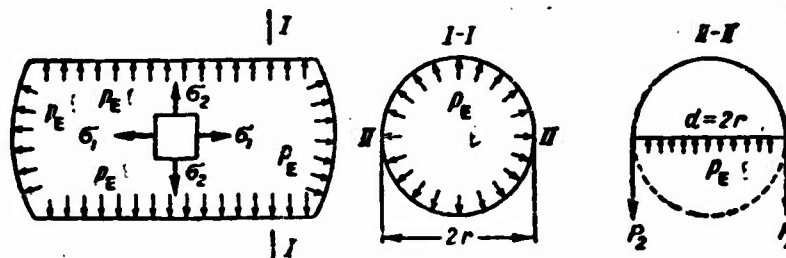

Fig. 4.16. Design diagram for a horizontal, cylindrical storage tank subjected to an excess pressure.

and the corresponding stresses

$$\sigma_2 = \frac{P_2}{\delta} = \frac{p_E r}{\delta} \quad (4.100)$$

Designing Bases

We shall look at designing flat, conical and spherical bases for an equally distributed excess pressure type load.

Designing Flat Bases. The flat base is welded directly to the wall or via a croze angle. Therefore, the base can be

considered as a circular plate elastically restrained along the periphery. Using results of calculations on such plates, we can supply the formulas in final form.

In view of the symmetry the calculation will be made on a base strip of unit width which passes through the center and is subject to a load uniformly distributed across the base.

The maximum bending moment at the bases' center is (4.101)

$$M_{\max} = \frac{qr^2}{16} (1 + \mu),$$

and the corresponding stress is (4.102)

$$\sigma_{\max} = \frac{M}{W} = \frac{3}{8} \cdot \frac{qr^2}{\delta^2}.$$

The maximum bending moments at the base's periphery is (4.103)

$$M_{\kappa} = -\frac{qr^2}{8},$$

and the stress is (4.104)

$$\sigma_{\kappa} = -\frac{3}{4} \cdot \frac{qr^2}{\delta^2}.$$

The edge moment M_{κ} is quickly attenuated and equals zero at the distance $x = 0.6 (r\delta)^{\frac{1}{2}}$.

The deflection at the center of the base takes the form (4.105)

$$W'_{\max} = \frac{qr^4}{64D}.$$

where $D = \delta^3/12(1-\mu^2)$ is the cylindrical rigidity of the base.

Designing conical bases. When designing conical bases, one must remember that the vertical radius of curvature $r_1 = \infty$. Therefore, one can easily get an expression for the circular forces from formula (4.8)

$$N_2 = qr_2, \quad (4.106)$$

where r_2 is the circular radius of curvature, which is a function of the distance of the point under consideration x to the apex of the cone (fig. 4.17). From the diagram it is clear that $r_2 = x \tan \alpha$; therefore, the circular force can be written in the form

$$N_2 = qx \tan \alpha, \quad (4.107)$$

and the corresponding stress is

$$\sigma_2 = \frac{qx \tan \alpha}{\delta}, \quad (4.108)$$

The result of formula (4.108) indicates that the circular forces are zero when $x = 0$ at the cone's apex, and the highest stresses will be at the junction of the base and the cylinder.

Vertical forces N_1 and stresses σ_1 , because of the equilibrium conditions for a cone, will be half as much as the circular forces found by formulas (4.107) and (4.108).

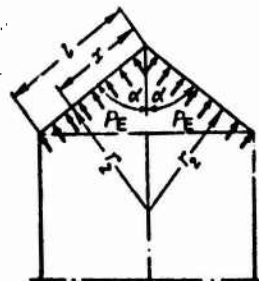

Fig. 4.17. On designing a conical base.

Designing Spherical Bases. In a spherical base subject to a uniformly distributed load, the vertical and circular forces are equal to

$$N_1 = N_2 = q r_{sf} / 2, \quad (4.109)$$

where r_{sf} is the sphere's radius.

Since the circular forces in the storage tank's wall $N_2 = q r_{cyl}$ (r_{cyl} is the radius of the cylinder) are twice as great as the corresponding forces in the sphere, then the radius of the spherical base must be equal to twice the radius of the cylindrical section of the housing, if the walls and the spherical base are to be uniformly strong.

Chapter Five

GAS STORAGE TANKS

§ 1. Designation and Classification of Gas Storage Tanks

Gas storage tanks were conceived with the birth and development of the gas industry. At first they were used only to store illuminating gas and were set up chiefly at gas manufacturing plants. Today, the importance of the role gas storage tanks play in storing gas for distribution to consumers has diminished. However, their importance has grown immeasurably within chemical manufacturing enterprises, where they are used to store gases which are, for the most part, semi-finished products to be used in various gas mixtures or as pressure regulators in gas systems etc.

Gas tank construction has experienced some significant changes during development within the gas and chemical industries. Thus, although the first gas tank was a simple, rectangular affair, now it is a complicated and important installation, usually cylindrical in shape, and requires a high degree of precision in manufacture and assembly.

Modern gas tanks are classified by stored gas characteristics and technical production requirements, as well as by the type of construction. For the most part, gas tanks are classified in terms of the characteristics of the stored gas:

Class I - category gas tanks are for low pressures (a working pressure of 400 mm of water),

Class II - category gas tanks are for high pressures (a working pressure of 0.7 to 30 kg-f/cm²).

The principal difference between low and high pressure tanks is that the volume in the former is variable, so that gas pressure during filling or emptying operations remains constant or else the change is insignificant, whereas in high pressure tanks the geometric volume remains constant so that the pressure during the filling operation varies from an initial value to the operating value.

Gas tank classes are subdivided into groups and types. Thus, Class I, depending on the operating principle and type of construction, is divided into two groups: 1) wet and 2) dry type gas tanks. Each in turn is further divided according to construction into vertical and helical wet type tanks, or piston and flexible section, dry type tanks. High pressure (Class II) tanks are subdivided according to construction into either cylindrical types with spherical bases or spherical (globe) types. Cylindrical tanks can be further classified as either vertical or horizontal. A basic classification system for gas tanks is given in table 5.1.

Table 5.1

Low Pressure Gas Tank				High Pressure Gas Tank		
Wet Type		Dry Type		Cylindrical		Spherical
With Vertical Tracks	With Helical Tracks	Piston Type	With a Flexible Section	Horizontal	Vertical	

§ 2. Vertically Moving Wet Type Gas Tanks

This type of gas tank (fig. 5.1) is widely used because of its simple construction which can be mastered easily and its reliable operation.

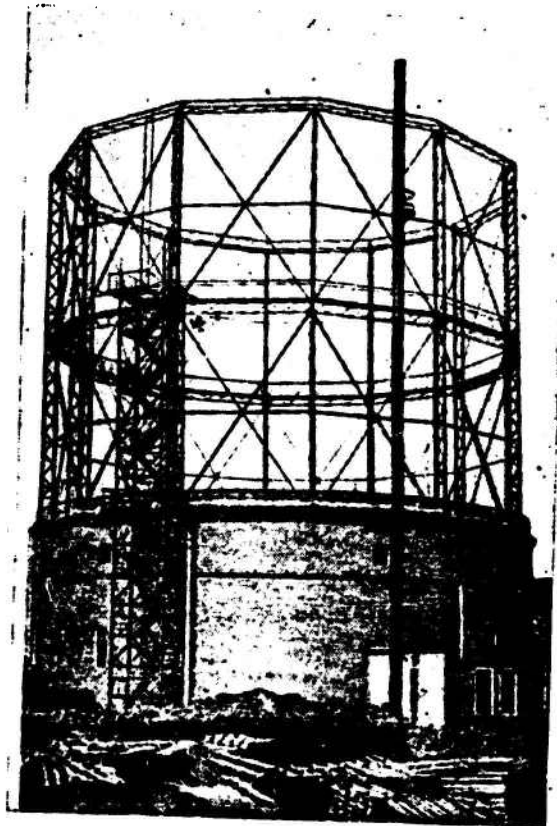

Fig. 5.1. Overall view of a wet type gas tank with vertical tracks.

Wet type gas tanks are made in two sections: a vertical, cylindrical storage tank filled with water (the fixed section) and a cylindrical float open from below and capped with a spherical cover (the moveable section) which is positioned at the center of the tank. The float is really the gas storage compartment.

When filling the gas storage tank, gas enters through a vertical standpipe under the float. As soon as the total gas pressure against the cover exceeds the cover's weight the float starts to rise, moreover, the pressure will continue to increase until the volume outside the water equals the metal weight difference between that portion in water and that in air. The water in the storage tank acts as a hydraulic seal. When the gas tank is emptied the float drops and the water in the tank expels the gas.

In order to utilize the float volume to its maximum, its height is made equal to the storage tank's height. The gas volume under the spherical dome never leaves the space under the dome because the water level only comes up to the top of the float's cylindrical section. Thus, the volume under the spherical section is dead space in the float.

In large capacity gas storage tanks (over 6,000m³) the moveable portion is made of several sections and only the topmost section is called the float while the other sections, moving one at a time, are called telescopic sections. The moveable sections are sealed hydraulically; each has two circular channels, one within the other. In addition, bonding devices between sections act as hydraulic seals. There is no hydraulic seal between the lowest telescopic section and the gas storage tank itself.

The gas tank operates in the following manner. When gas is fed under the float, the latter rises to its full height. When its lower edge reaches the water's surface, the hydraulic sealing channel scoops up water which enters the area meshing with the channel opposite it in the first telescopic section. In similar fashion, after the first telescopic section has been extended, the following section is actuated, etc. When the gas tank is being emptied, the lower telescopic section is lowered first, then successive ones until the float is reached. The use

of moveable sections within the gas storage tanks made it possible to make the storage tank height equal to the height of one moveable section; this lowers overall construction weight significantly. Wet type gas storage tanks can have one, two, or more moveable sections. The maximum number of moveable sections usually does not exceed six.

To avoid misalignment problems when the float and telescopic sections are in motion and to absorb the horizontal loads caused by wind pressure against the lateral surfaces or skewing because of snow loads on the float roof, each moveable section is fitted with a system of internal and external rollers which transmit the lateral loads to the guide system. The external rollers are set on special brackets and are evenly distributed around the upper edge of each moveable section, so that when the section moves they roll on external, vertical guides which run as high as the highest moveable section. The external tracks have a fixed dimensional geometry similar to a multifaceted prism. I-beam or grating type track pillars are distributed along the prism angles. The pillars are connected with stiff collar beams, 1, (fig. 5.2) as well as by a system of diagonal ties 2. Platforms for inspecting the storage tank are frequently constructed at the circular collar beams around the top of each section (except for the float). The entire external track system is rigidly attached to the upper plate layers of the tank. Internal rollers are set up along the lower edge of each moveable section and roll along internal tracks when the section moves; these are attached directly to the internal wall surfaces of the tank and telescopic sections. Usually there are twice as many internal tracks as external ones.

The foundation for a wet type gas storage tank is a fabricated, solid, ring of reenforced concrete inside of which there is an earthen-sand base. The minimum width of the ring is

$$B_{\min} = \frac{1}{2} (D_R - D_F) + 200 + 150$$

where D_R is the storage tank outside diameter; D_F is the float diameter; the 200 and 150 mm are the respective clearances of the outside part of the ring from the storage tank wall and from the inside of the float.

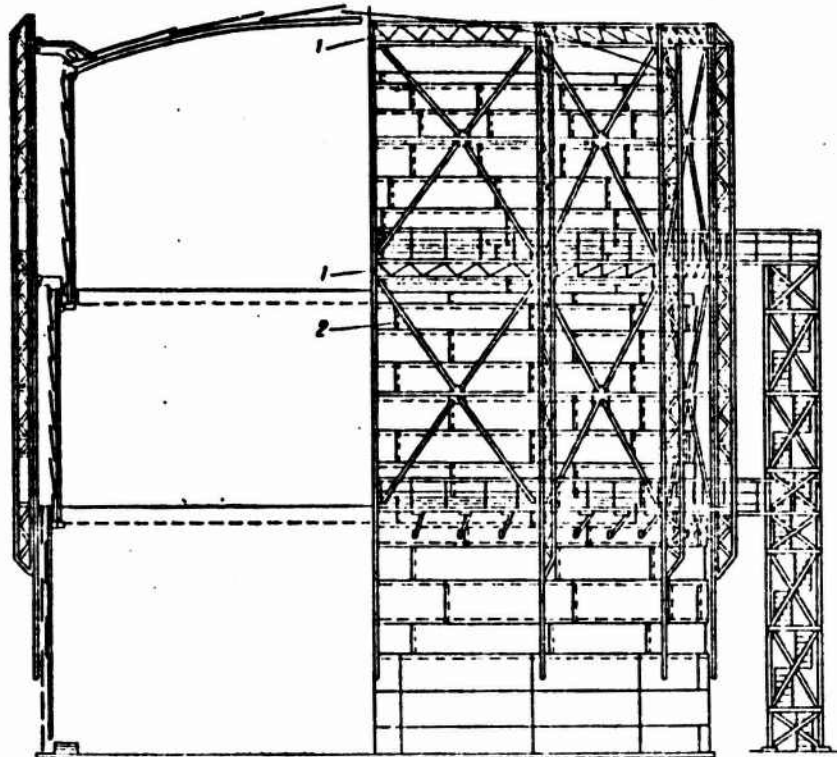

Fig. 5.2. Construction diagram of a two section gas storage tank

One of the characteristic features of the foundation is that it has reinforced concrete slabs set around the ring where the transition is made from the foundation ring to the sand cushion. The fact that the slabs can move freely with respect to the bearing points on the foundation allows the base to flex smoothly if the sand base settles significantly.

In contrast to the usual vertical, steel storage tanks, wet type gas storage tanks have the following special features: there is a circular staging area around the upper edge of the housing wall which also acts as a stiffening ring. It is attached to the

uppermost belt of plates which, for this reason, is thicker than the other belts. Internal tracks made of channel stock are attached to the inside surface of the housing wall. Radial support beams 200 mm high are distributed around the housing perimeter at the bottom of the tank; they support all the moveable sections when lowered and protect them from any dirt which may accumulate on the bottom during operation.

It must be noted that a pre-stressed reinforced concrete gas storage tank can be used in place of steel, wet type tanks. In this case, apart from the economy of steel, the reinforced concrete storage tank has a number of advantages: reinforced concrete is less susceptible to corrosion which is a nuisance in wet type gas tanks; the reinforced concrete tank can be set deeper in the ground thus reducing installation height and lessening the affect of wind loads and, thanks to the insulating properties of the earth, reduces the cost of heating the water during the winter etc.

The float in a wet type storage tank is made up of a load bearing frame and covering. The load carrying frame in the float wall has upper and lower stiffening rings connected together with vertical, tubular struts. The upper stiffening ring is made of the thicker upper belt layer float wall material, crozed angle bar and thicker edge roofing material. The lower stiffening ring is made from the same thick material used in the lower belt of the float and has a horizontal ring made from sheet steel. In tanks which have only one section, a preload is put on the internal wall of this ring which in multisection units, has, in addition, on the lower end of the inside wall a channel for a hydraulic seal. Since the pressure inside the float is small, its wall material is 3-4 mm thick. The thin section of the wall is not welded to the vertical struts.

The frame for the float's spherical cover is made of radial trusses formed into a spherical shape and they bear against the vertical wall struts, and are tied together with multisided rings

and diagonals. At the cover perimeter the trusses are tied together with a thicker roofing material and crozed angle bars. The roof covering is 2.5-3 mm thick and is welded only at the ends; the rest of it lays loose on the trusses. Thus, when exposed to gas pressure the float's roof covering can rise freely so the frame supports no load other than its own weight.

The rise of the spherical covering is

$$f \approx \frac{1}{15} D_F,$$

whence the sphere radius is

$$R_{\text{sph}} = [(D_F^2/4) + f^2] / 2f$$

or using the preceding expression,

$$R_{\text{sph}} = 1.9083 D_F.$$

The telescopic sections in a multisection storage tank are complete cylinders; the housing likewise is made from a frame and a cover 3-4 mm thick. The upper and lower frame stiffening rings are made from the respective thicker upper and lower housing belt materials and also have channels for hydraulic seals.

A horizontal circular plate is substituted for the hydraulic seal channel in the lower telescopic section. The rings are connected by vertical struts made from I-beams which serve as the internal tracks for the lower rollers in the float or for the preceding telescopic section.

Each hydraulic seal channel is deep enough to withstand a column of water equal to the gas pressure plus a reserve to handle possible misalignment in the moveable section and allows for seal waviness.

The number of gas conduits in the storage tank depends on its function within the enterprise's technical network. The gas conduits pass through special tunnels in the circular foundation and enter the gas tank at the base. To prevent water from entering gas line standpipes are 100-150 mm higher than the water level in the storage tank. The equipment for controlling the gas storage tank is located in a special booth over the areaway where the approach gas conduit has been placed. The cross-section of the supply lines is selected on the basis of how fast the moveable sections can travel along the vertical. However, this should not exceed 1.5 m/min.

Gas pressure in wet type gas storage tanks is related to the weight of the moveable sections. Since this weight usually is not sufficient to create the required operating pressure in the tank, the float is preloaded with concrete or cast iron weights. The concrete weights are placed along the float's edge while the cast iron pieces are put along the horizontal ring's projection on the lower inside in the float. To maintain float stability, 1/3 of the weight is placed at the edge and 2/3 on the ring. The following simple formula can be used to find the gas pressure in gas storage tanks which have various numbers of moveable sections:

In a single section gas tank

$$p = \frac{4}{\pi D_F^3} \left[Q_F - \frac{Q_F'}{7.85} - V_F (\rho - \rho_1) \right];$$

In a two section gas tank which has a telescopic section and a higher float

$$p = \frac{4}{\pi D_T^3} \left[Q_F + Q_T + Q_F' - \frac{Q_T'}{7.85} - (V_F + V_T) (\rho - \rho_1) \right];$$

where p is the gas pressure in inches of water; D_F and D_T are the respective diameters of the float and telescopic section in meters;

Q_F and Q_T are the respective weights of the float and telescopic section in kg; q_F is the weight of the water in the float's hydraulic seal; V_F and V_T are the volumes of the float and telescopic section in m^3 ; Q'_T is the weight in kg of the submerged portion of the telescopic section in water; ρ and ρ_1 are the densities of air and gas at normal conditions ($t = 0^\circ C$ and $p = 760 \text{ mm}$ of mercury) in kg/m^3 ; 7.85 is the bulk density of steel.

Basic dimensions of wet type gas storage tanks are obtained by analyzing data on existing or already designed units. Usually the ratio of the tank diameter to the overall installation height with all sections raised varies from 0.8 to 1.3. The height of the cylindrical, moveable sections is the same but the overall height of the tank wall is higher by that amount equal to the height of the support roller. The diameter of each succeeding section is less than the preceding by 1100 mm, i.e. the clearance between each pair of walls is 550 mm.

The useful volume of a gas storage tank can be found by the following formula

for a single section tank

$$V_1 = \frac{\pi D_F^2}{4} (H_F - h);$$

for a two section tank

$$V_2 = \frac{\pi D_F^2}{4} H_F + \frac{\pi D_T^2}{4} (H_T - h_2 - h);$$

for a three section tank

$$V_3 = \frac{\pi D_F^2}{4} H_F + \frac{\pi D_{T_1}^2}{4} (H_{T_1} - h_2) + \frac{\pi D_{T_2}^2}{4} (H_{T_2} - h_2 - h),$$

where H_F , H_{T1} and H_{T2} are respectively the heights of the float wall, and the first and second telescopic sections; h_3 is the depth of the hydraulic seals; and h is the amount that the float is submersed in water or in the lower telescopic section.

At present, in the USSR, all wet type gas storage tanks which have vertical type tracks are built to standard designs as follows (capacities in m^3): 100; 300; 600; 1,000; 3,000; 6,000; 10,000; 15,000; 20,000; 30,000.

In areas where temperatures are expected to go below $-20^{\circ}C$ a brick heating wall 350 mm thick is installed in a separate circular section of the foundation around wet type gas storage tanks. Its height is equal to the tank height. The distance between the brick wall and the outside housing surface is 1000 mm and a narrow circular passageway is built around the gas tank which is used to inspect the tank housing and pipelines and to watch instruments. Water temperature in the tank and at the hydraulic seals must be no less than $5^{\circ}C$ regardless of the ambient air temperature in order to operate; therefore, wet type storage tanks need to have heating devices - these allow steam to flow from the steam lines into the storage tank and to hydraulic seals, then into the water via steam-jet conveyors. The conveyors help to distribute the heating water uniformly around the hydroseals. Steam reaches the circular steam lines in the moveable sections through flexible hoses.

During operation wet type gas storage tanks are exposed to very corrosive conditions. The internal surfaces of the sections, when in use, are subjected to humidity and are exposed to corrosive gases which may be stored in the tanks and this can cause severe corrosion. The external surfaces also are subjected to corrosion by the atmosphere.

One of the methods used to combat metal corrosion in gas storage tanks is to apply different compositions of anti-corrosive paints on the surfaces. The cheapest method of providing protection is to use a protective liquid made from dissolving polyisobutylene into industrial oil which has been mixed with asphalt materials. The protective material is poured into the storage tanks on the water's surface and it applies a protective film whenever the moveable sections are raised. The liquid is applied to the internal roof surface by special moveable or rotating atomizers.

§ 3. Wet Type Gas Storage Tanks with Helical Tracks

Wet type gas storage tanks (fig. 5.3), just like the gas tanks with vertical tracks, have a storage area for water and one or more moveable sections (float, telescopic units).

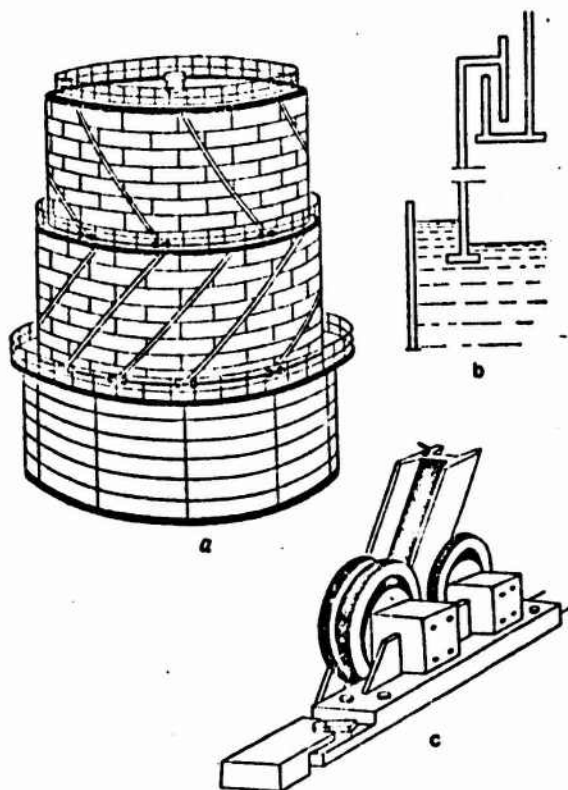

Fig. 5.3. Wet type gas storage tank with helical tracks.
a- gas storage tank; b- hydroseals; c- roller pairs.

These gas tanks differ from vertical track gas storage tanks by the way the moveable sections are raised and lowered. Whereas the moveable sections in the latter only move in the vertical direction, gas tanks with helical tracks move up or down while rotating around the vertical axis.

In other words, when being raised each succeeding unit section, so to speak, is threaded out from the preceding one and when being lowered is threaded in. This process takes place using a special system of paired rollers and tracks.

The tracks for these types of gas storage tanks are made from railroad rails which are made from welded H-beams or specially rolled shapes. They are installed on the housing at a 45 degree angle in such a manner that each section makes contact on a helical line. The entire length of each track is welded to the section wall, and also through the wall to the vertical struts inside the cylindrical section housing. Like the vertical type of wet gas tank, each moveable section is constructed in such a manner that a stiffening belt made of steel thicker than the entire wall can be attached to the upper and lower wall sections. The belts are attached to the vertical struts with pairs of angle brackets. The number of struts is greater here than in vertical track types because they receive the forces transmitted by the rollers to the helical tracks.

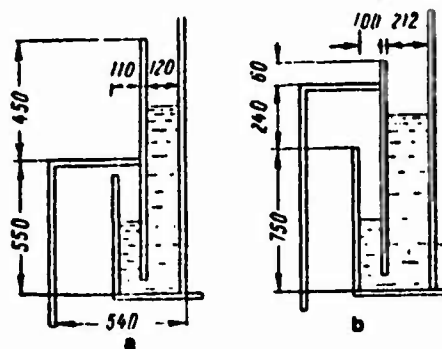

Fig. 5.4. Hydraulic seals in wet type gas storage tanks: a- with vertical tracks; b- with helical tracks.

The system of paired rollers is set up around the upper perimeter of the storage tank and telescopic sections. Each pair of rollers is set on a support plate attached to a bracket on the storage tank or to the upper hydroseal channel area. The track goes between the rollers and only one roller, depending on the direction of applied force, carries the load. To keep the moment of gyration from increasing when the float or the telescopic section moves downward, the track is set at a different direction at each subsequent section, i.e., a type of thread equalizing construction so to speak, so that if the lower section has a right hand thread, then the next is left handed.

The helical track is the most important element in the construction and is the most complicated to make and maintain. If horizontal or unsymmetrical vertical loads are applied, the track can be deflected, compressed or twisted. This makes it necessary to increase the number of vertical struts in the moveable sections. Since the horizontal forces on each of the sections increase as they are lowered, then the number of tracks must also increase (usually one and one half times).

Methods of making hydraulic seals in wet type gas storage tanks are shown in fig. 5.4. In gas storage tanks which have helical tracks (fig. 5.5) the upper hydraulic seal channels do not have high projecting plates because rollers are installed along the upper channel. As a result of this the channels are deeper.

Helical gas storage tanks usually have a larger diameter than the ordinary gas storage tanks in order to lower the pressure on the rollers and helical tracks. The ratio of diameter to

the total height is around 1.2 - 1.75.

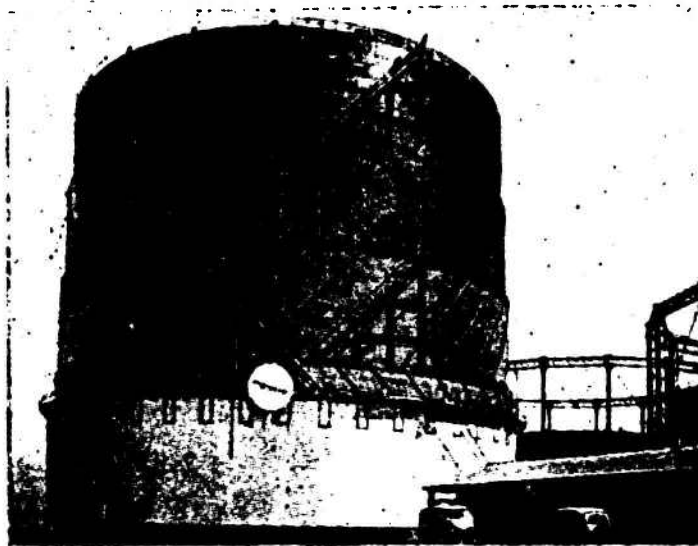

Fig. 5.5. Gas storage tank with helical tracks.

Gas storage tanks of the type just examined have the following special features as compared to vertical track types:

- a) greater operational reliability;
- b) lower installation height when the sections are down (storage tank height);
- c) economical in the use of steel (around 10%);
- d) mechanical parts (rollers) are accessible for inspection and lubrication and there are less total parts.

More complex manufacture, assembly, and tighter assembly tolerances are disadvantages.

§ 4. Dry, Piston Type Gas Storage Tanks

Wet type gas storage tanks have a number of disadvantages such as high cost, they require large amounts of metal and the installation and water must be heated during the winter. Moreover,

dehydrated gases cannot be stored because they will absorb the water in the tank during storage. Therefore, dry types of gas storage tanks were developed because of additional production needs.

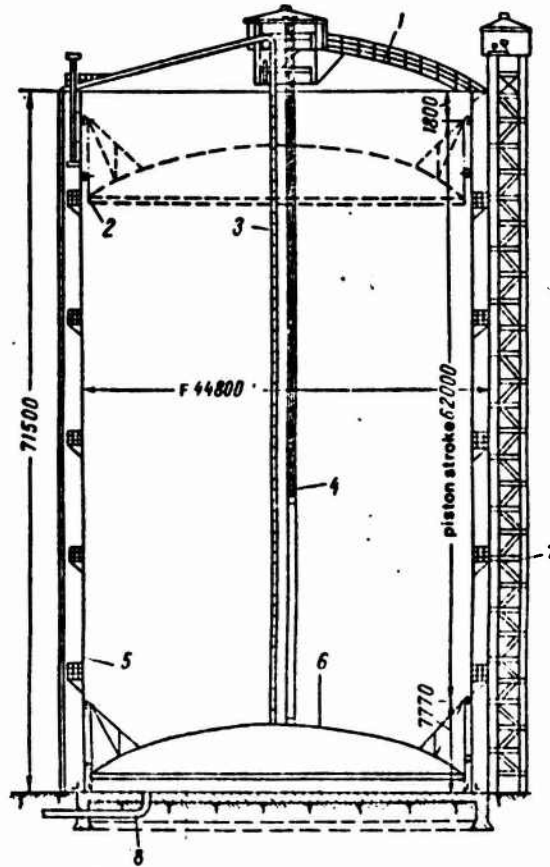

Fig. 5.6. A 100,000 m³ dry type gas storage tank with a liquid seal.

1- roof; 2- upper ring (piston) position; 3- chain step ladder; 4- lift stand; 5- gas tank wall; 6- ring; 7- external elevator; 8- gas line.

The first dry type gas storage tanks were built by the German firm MAN, then followed by the "Klönne" and "Bamag" firms. Recognizing the economical features of this new type of construction, many countries started to build dry type gas storage tanks with large capacities. Thus gas storage tanks with capacities of 300,000 and 347,000 m³ were built in Germany and of 566,000 m³ in the USA. However, they proved to be expensive to operate and were not very reliable. After a number of serious breakdowns the introduction of dry type storage tanks into industry was suspended.

At present, dry type gas storage tanks are used in the USSR chiefly to store neutral gases (nitrogen, for example).

Dry type gas storage tank construction features a vertical housing with a cylindrical or polyhedral shape, a bottom, and roof coverings. A moveable plate (piston) is inside the housing. The operating principle of the dry gas tank is similar to that of a steam engine. There is a special seal between the plate and the wall. The plate, by the action of gas pressure under it, rises to a predetermined point. When gas is released, the plate drops to a terminal point, using its weight to maintain a constant gas pressure.

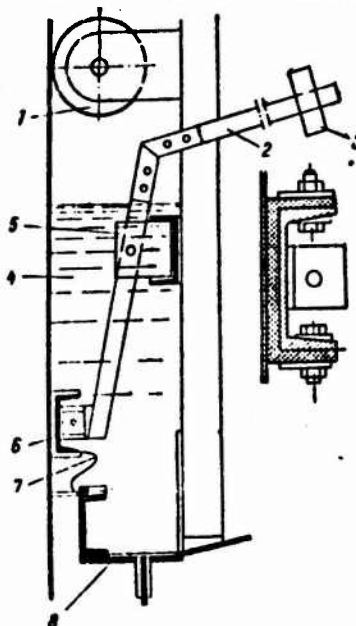

Fig. 5.7. A liquid VDK seal for dry type gas storage tanks.

1- alignment roller; 2- clamping device lever; 3- counter-weight; 4- gas tank oil; 5- lever support; 6- clamping ring; 7- apron; 8- bottom of the plate.

A method has been developed in the USSR of building dry type gas storage tanks with liquid seals (fig. 5.6). The gas tank wall is made of an external frame containing vertical I-beam struts and horizontal rings made from angles or channel, and a sheathing 5mm thick. External, circular platforms are set in the housing. The gas tank roof is made of radial trusses formed into a spherical shape and covered with 3 mm thick sheet stock. The plate is

essentially a rib and circle dome with a lattice around the perimeter which stiffens the entire plate and to which sealing devices are attached along the lower edge and also it has two tiers of wooden rollers. The distance between roller tiers is designed to be 0.125 of the plate diameter which prevents misalignment during operation. A ventilation skylight is put into the roof to ventilate the space above the piston; it has a row of vent apertures in its upper section. The gas storage tank has a vertical elevator and a chain step-ladder with a counter-weight which service personnel use to get to the roof and to the external surface of the plate.

VDK seals (fig. 5.7) are used as sealing devices. The seal's clamping ring is made from short channel sections to which soft seals made of several layers of fabric are attached; these slide along the housing wall. Each channel section is pressed against the wall by a lever and counter-weight. The lower section of the ring is connected to the plate with an apron. Gas tank oil is poured into the space above the apron and between the wall and plate. The column of oil is designed to withstand the tank gas pressure. The oil trickles through and seals the space between the ring and the wall. Then the oil drains down along the wall to a circular oil header, from here it passes through filters and settling tanks and then is automatically pumped up through special openings in the housing wall. The oil then again seeps down along the wall from the openings into the seal. The advantage of this type of seal is in the large displacement range of the clamping levers which can cover large clearances and consequently reduce the tolerances in manufacture and assembly.

§ 5. Dry Type Gas Storage Tanks with Flexible Sections

As the chemical industry developed, requirements arose for construction types which could store dehydrated gases and highly concentrated gases; this construction had to be safer and more reliable in operation. Dry type gas storage tanks with flexible sections were made to serve these purposes. We must note

that these gas storage tanks were created not only because of the needs of major chemistry but also resulted from the developments in the chemical industry because materials were used which did not exist 20 years ago.

The dry type gas storage tank with flexible sections works on the same principle as the piston type storage tank. The main difference between them is in how the seal between the plate and the housing wall is formed. The seal, or more correctly, the pressure sealing of the gas space in this type of construction is achieved by using a flexible section made of rubber-coated fabric which affixes itself to the gas tank housing and to the moveable plate thus making a pressure seal. In an empty tank, when the plate is down and resting on the support beams, the flexible section sheath which is affixed to the housing wall at approximately half the height of the tank's gas space spreads itself into the inter-wall space from the point where it is attached at the housing to the bottom of the plate. When the gas tank starts to fill, the plate starts to rise, lifting the lower edge of the sheath which at first starts to move away, then doubles up on itself and straightens itself out at the end of the ascent but now it is above its attachment point. Thus, when filling (or emptying) the gas tank, the flexible section's sheath inverts itself, its surface which is turned to the housing wall turns to the plate (or vice versa). As a result, in this type of construction the gas space is completely isolated from the space over the plate. High purity gases can be stored in these types of gas storage tanks because they neither come into contact with water nor with gas tank oil.

A dry type gas storage tank housing has walls 5 mm thick; the base thickness is 6 mm and it has a roof which can be spherical or conical. The wall and bottom are made from rolled stock; the covering looks like separate panels. A number of circular rings made of channel stock are attached to the wall to stiffen it. A circular platform is set up half way up the gas tank. A

little higher than $1/3$ up there is a door to enter the tank when the plate is completely down. The gas tank's base is raised in the center and tapers away gradually. The difference in the level between the center and the perimeter of the base is 0.015R. Support beams are distributed around the base and the piston rests against them when in the down position. The gas tank roof is made from a support framework which looks like rafters tied to each other with horizontal rings and the covering is 3 mm thick. In a frame and panel arrangement of elements, the roof rafters and sections of the horizontal rings are tied together by a covering into separate panels, which are then used to erect the roof. A circular edging 6 mm thick is put around the roof's perimeter and this is the crozing piece for the entire roof. The roof has boxes which contain tensioning devices for cables to equalize the system; there is a central ventilating hatch with a skylight and a gas discharge device. A guardrail runs along the edge. The gas tank must be equipped with lightning rods.

Gas is piped into the tank through the base. The gas line can be run through an intermediate chamber on the side.

The gas tank's piston consists of the support frame base, the frame walls and its own protective wall. The base itself is 5 mm thick. The upper portion of the base has its own frame which is made from radial I-beams connected together with a central ring and angle spacers. The beams are welded to the base plates. The beams have circular spaces made from angles to handle concrete weights. An angle runs around the perimeter of the base and the flexible section is attached to it. Vertical I-beams in the framework for the protective wall, strengthened with braces, are located at the ends of the radial beams and they join to the edge of the base. The struts are connected by horizontal rings made from formed angle stock. A circular area runs around the top of the struts; this serves as a stiffener and a mounting for the rollers which adjust the system. Protective wall panels 3 mm thick are attached to the horizontal rings with bolts. Bolting the wall panels to the rings makes it possible to

adjust their positions on the frame - it gives the entire wall a cylindrical appearance and it maintains an even circular clearance around the entire perimeter. When in use, the flexible section bears against the protective wall and this protects it from making contact with the sharp edges in the piston frame.

The balancing system which protects the piston from misalignment when moving contains six or eight pairs of rollers and the same number of steel cables. Each cable is attached to a special box on the gas tank roof via a tension spring, then it drops down inside the housing, goes around underneath one of the plate rollers, around its centerline and up to exit through a special window with a shroud in the housing wall to the outside where the other end is secured. The cables are thickly coated with grease to prevent making sparks when in use.

The gas storage tank's flexible section is made from polycaprolactam fabric which has layers of butyl or nairite rubber impregnated into both sides by hot rolling. Cloth is usually 1 m wide and thickness is 2-2.5 mm. In manufacturing the sheath individual pieces of cloth are bonded together and then several seams are stitched in and it is then covered with a thin coating of rubber. Polycaprolactam thread is used for the seams. The upper and lower edges of the cylindrical sheath are made thicker by adding extra strips. After bonding, all pieces are cured.

Flexible section dry gas storage tanks do not require a special foundation and are usually built with artificial, sand foundations as vertical, cylindrical storage tanks with capacities up to 5,000 m³. A water absorbing layer is put over the sand cushion to protect the gas tank base from corrosion.

Some of the disadvantages of this type of gas storage tank are the large volume taken up by the piston which cannot be used to store gas (about 1/3), the high price of the material for the flexible section and its limited operating life (about five years).

§ 6. High Pressure Gas Storage Tanks

High pressure gas storage tanks are divided into cylindrical and spherical types. The geometrical volume does not change but the pressure changes by the amount it is full (or empty).

The geometrical volume of this class of gas storage tanks is quite a bit less than the volume of low pressure gas storage tanks; however, the amount of gas being stored can be significant thanks to the high pressure. Disregarding the small temperature change which takes place when gas pressure changes, i.e., assuming that the gas, when released from the tank through a reducing valve, expands isothermally ($T=\text{const}$), we can find the volume of gas being stored in a tank under normal conditions. If the process is isothermal

$$p_1 V_1 = p_2 V_2 = pV = \text{const},$$

Hence

$$V_2 = p_1 V_1 / p_2.$$

For example, in a 100 m^3 wet type gas tank, the actual volume of gas at a pressure of 0.04 kg-f/cm^2 (400 mm of water) is

$$V_2 = 1.04 \cdot 100 / 1.0 = 104 \text{ m}^3$$

In a high pressure gas tank storing the same volume of gas at a pressure of 16 kg-f/cm^2 the volume will be

$$V_2 = 17 \cdot 100 / 1.0 = 1700 \text{ m}^3$$

i.e., the actual amount of gas is almost 17 times more than in the first case (we must remember that the absolute value of pressure must be used in these types of calculations).

High pressure gas storage tanks are widely used in the chemical and metallurgical industries as well as at gas storage stations which provide gas service to cities.

Cylindrical Gas Tanks

Construction of cylindrical, high pressure, gas storage tanks may take two forms: a cylindrical housing section and spherical bases. The cylindrical section is made from separate courses 2,000 or 2,400 mm long, depending on the width of the steel sheet. The courses are butt welded together automatically using a flux. The end faces for the cylindrical section are finished off with polyspherical bottoms, welded together from individual lobes. Gas tanks with this type of construction are manufactured at a factory, tested, and then erected at the assembly area in finished form. Their volumes are 50, 100, 175 and 270 m³ and the inside diameter is 3,200 mm. Consequently, those tanks which differ in volume, differ only in the length of the cylindrical section. The working pressure in gas tanks can be 2.5, 4.0, 6.0, 8.0, 10.0, 12.5, 16.0 and 20.0 kg-f/cm². Gas tanks must comply with "Rules for the construction and safe operation of pressure vessels" from Gosgortekhnadzor of the USSR. Gas tank walls which are made from low carbon steel are no thicker than 12 mm. If low alloy steel is used (for higher pressures) the thickness can approach 30 mm.

Cylindrical gas tanks are used in the horizontal position and are supported by four support struts, usually pipe sections. When strut pairs are installed, the shell is reinforced internally with stiffening rings. The struts are supported on concrete foundations.

Gas tanks set up vertically are supported by several separately standing support struts which are connected by diagonal ties. In addition the vertical gas tanks are usually deployed in

groups (batteries) and they are connected by horizontal staging set up on the top or intermediate level and this acts as additional tie points.

High pressure gas tanks are tested with water before the air is expelled and filled with gas; all the supports are designed to withstand the shell weight and the weight of the added water.

Spherical Storage Tanks and Gas Tanks

Spherical (globe type) storage tanks and gas tanks (fig. 5.8) are used widely to store nitrogen, ammonia, hydrogen, liquefied gases (gas storage tanks) and low boiling point liquids (storage tanks) under high pressure (2.5 - 18 kg-f/cm²). The methods of constructing globular storage tanks and gas tanks are identical. The difference between them is in what instruments are used during operation and in the fact that storage tanks supports are usually stronger so that the required hydraulic pressure heads can be set up.

The spherical shape of pressure vessels is more suitable for storing gas or low boiling point liquids under high pressure with respect to the amount of metal required and to overall cost. Thus, to store a product under the same conditions required 15% less metal for a spherical storage tank with a volume of 600 m³ than for a cylindrical one. However, this is practical only when the vessel's internal pressure is greater than 1 kg-f/cm². A so-called relative steel expenditure index may be used to make a comparative evaluation of metal expenditure for one or the other envelope type (spherical or cylindrical)

$$q = Q/V_p k_{p_{rel}},$$

where Q is the amount of steel in kg needed to build the shell; V_p is the volume of the envelope in m³; k is the vessel space

factor; p_{rel} is the relative pressure in the vessel

$$p_{rel} = \frac{p_{exc}}{p_{atm}}$$

here p_{exc} and p_{atm} are the excess and atmospheric pressures in the vessel.

The dimensionless quantity p_{rel} equals the excess pressure in the vessel.

The shell of the storage tank or gas tank is made from individual petal-like segments placed horizontally and automatically welded. Depending on how the segments are arranged, the shell can have one, two, or three belt layers. All the petal forms near any opening close by the upper or lower sphere poles about the spherical bottom segments. The petals and bottom segments are made at special factories. Shell thickness is determined by the design and depends on the working pressure, it can vary from 12 to 34 mm. Shell material is usually low alloy steel. Spherical gas tank volumes normally range in 300, 400, 600, 800, 900, 1,200, 2,000 and 4,000 m³ sizes.

Automatic welding with flux is used exclusively in building globular storage tank and gas tank envelopes because it yields the maximum amount of automation and work mechanization, increases the installation reliability, and makes it possible to increase the joint strength coefficient.

Supports for the storage and gas tanks are made from cylindrical, reinforced concrete liners containing steel support rings, or else from separate column supports attached to the sphere's diameter and connected together with tension bars. Sometimes, if the tank capacity is small, it is preferable to attach the supports

at some distance away from the sphere's diameter and at an angle tangent to the globe's attachment point. Then, they look like baskets. The load is transmitted through the columns to the re-enforced concrete ring in the foundation which has separate posts under each support. A steel support plate is installed on the posts where the column joins; it has anchor bolts to reenforce the support shoe. The support is connected to the gas tank housing via a steel cover plate which has been rolled into a spherical shape. The support design load is the envelope weight plus the water within because spherical gas and storage tanks are tested with water.

Spherical gas storage tanks are fitted with ladders and access holes to get inside for repairs and also have gas input and output lines. Gas tanks which store liquefied gases are usually insulated.

Because they are high pressure vessels, globe type storage and gas tanks come under the jurisdiction of the Gasgortekhnadzor inspectorate.

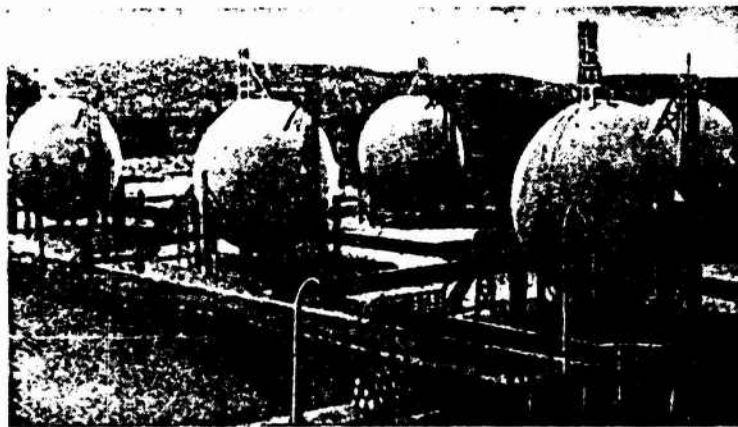

Fig. 5.8. Spherical Storage Tanks

GAS STORAGE TANK DESIGN

This chapter covers those design aspects intrinsic only to spherical gas storage tanks because general gas tank design elements have been covered in sufficient detail in chapter 4.

§ 1. Finding The Support Reactions in a Wet Type Gas Tank Foundation Ring.

A wet type gas storage tank is rather high, so it sees a significant wind load which is transmitted through the track system and the storage tank into the foundation ring. A diagram for finding the support reactions in the foundation ring is shown in fig. 6.1.

We shall use the following notations:

ΣW - the resultant wind load in kg-f;

h - the height of the point above the foundation ring at which the resultant is applied, in cm;

P_o - the maximum reaction of the wind load at point A in kg-f/cm²;

q_o - ring reaction to wall weight and external tracks in kg-f/cm²;

Q - tank wall and track weight in kg;

P_A - total reaction at point A in kg-f/cm;

r - storage tank radius in cm.

The summed wind load against the gas tank, ΣW , has a value which acts in a direction opposite to the reaction and causes the tank base to rub against the foundation. However, since the point at which ΣW is applied is at some height h (the height of the building's center of gravity projected in the vertical plane), an over-turning moment ΣWh is created which is equal to

the reaction moment at the foundation ring. We must note that this reaction occurs only at the lee side of the storage tank. This is not present on the windward side because the tank is not restrained.

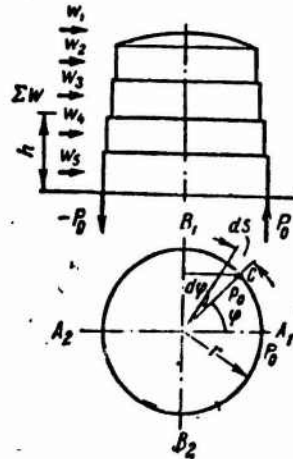

Fig. 6.1. Finding the support reaction in a wet type gas storage tank foundation ring.

Since the circular wind load can be found with sufficient accuracy by

$$q = q_B \cos \phi,$$

where q_B is the normalized velocity pressure; we shall say that it and the distribution of reactions around the foundation are proportional to $\cos \phi$, i.e. the reaction at any arbitrary point will be

$$P_c = P_0 \cos \phi$$

The sum of the forces on an infinitely small arc element ds is

$$dP = P_c ds = P_c r d\phi = P_0 r \cos \phi d\phi$$

This reaction leads to the moment around the B_1B_2 axis

$$dM = dPr \cos \phi = P_0 r^2 \cos^2 \phi d\phi$$

Then the sum of all the moments resulting from the reaction which act on half of the ring will be

$$M = 2 \int_0^{\pi/2} P_0 r^2 \cos^2 \phi d\phi = 2P_0 r^2 \cdot \frac{\pi}{4}$$

Equating this expression for the moment to the moment due to the wind load

$$\frac{1}{2} P_0 r^2 \pi = \sum Wh$$

whence

$$P_0 = 2 \sum Wh / \pi r^2 \quad (6.1)$$

The reaction due to the storage tank wall weight and external tracks, uniformly distributed around the entire periphery is:

$$q_0 = Q / 2\pi r$$

The total reaction at point A is

$$P_A = P_0 + q_0 = \frac{2 \sum Wh}{\pi r^2} + \frac{Q}{2\pi r} \quad (6.2)$$

If the cross section area of the foundation ring is to be found, we must find the reaction due to the total gas storage tank weight (with the sections down) and make allowances for the larger values in the design.

§ 2. Designing The Moveable Sections in a Wet Type Gas Storage Tank

The wall thickness of the float and telescopic cylindrical sections is found by the usual formula for cylindrical housings

$$\delta = npr / mR\phi, \quad (6.3)$$

where p is the gas working pressure in kg-f/cm^2 ; r is the radius of the cylindrical housing in cm ; n is the overload factor ($n=1.2$); R is the design load of steel in kg-f/cm^2 ; m is the working condition coefficient ($m = 0.9$); and ϕ is the joint strength coefficient ($\phi = 1$).

Since the working pressure in the gas tank is not large (0.04 kg-f/cm^2), the wall thickness as computed by formula (6.3) is extremely small. Therefore, the telescopic section is made 2.5 - 3.0 mm thick and the float 3-4 mm thick. The stiffening ring around the cylindrical edge of the moveable section creates an edge effect. The differential equation (4.29) for the cylindrical envelope under a symmetrical load can be used to find the displacement, the bending moments, and transverse forces in the edge affect zone by

$$\frac{d^4w}{dx^4} + 4\beta^4w = \frac{p}{D}, \quad (6.4)$$

where w is the housing deflection along the radius; p is the internal pressure; and D is the cylindrical stiffness of the housing

$$\beta = \frac{\sqrt[4]{3(1-\mu^2)}}{\sqrt{r\delta}};$$
$$D = \frac{E\delta^3}{12(1-\mu^2)}.$$

Here μ is Poisson's ratio.

As before, the solution to equation (6.4), keeping in mind the long length of the housing ($C_1 = C_2 = 0$), can be written as

$$w = e^{-\beta x} (C_3 \cos \beta x + C_4 \sin \beta x) + \frac{pr^2}{E\delta}. \quad (6.5)$$

Since the ring is very stiff when compared with the stiffness of the thin housing envelope, and the pressure is extremely small, the envelope edge can be considered to be fixed. Then the boundary conditions are

$$w|_{x=0} = 0, \quad \frac{dw}{dx} \Big|_{x=0} = 0,$$

whence

$$C_3 = C_4 = -\frac{pr^2}{E\delta}.$$

Furthermore, remembering the differential relation during bending

$$M = -D \frac{d^2 w}{dx^2}$$

$$Q = -D \frac{d^3 w}{dx^3},$$

we can find all the parameters of interest for the envelope stress condition near the edges. Again we note that because the load is small in this case, we disregard ring deformation. For this reason then, instead of making a complete calculation, we can reduce

the effort to finding the point in the zone width where the edge effect disappears

$$b \approx 2.5\sqrt{r_0}.$$

Here b is the height of the thicker belt layer.

§ 3. Designing The Float Roof in a Wet Type Gas tank

The float roof is designed to meet two situations:

1) The gas tank is full of gas; the design essentially calls for a spherical envelope for the roof (to carry the internal pressure) and crozing ring type construction (to carry the compressive forces being transmitted by the envelope);

2) There is no gas; the design calls for a roof framework (to carry its own weight and the snow load) and crozing ring type construction (to carry the tensile forces transmitted by the trusses).

We shall now look at how to design a roof for the first case. In a filled gas tank the spherical roof envelope is subjected to the internal pressure, just as though the wind were blowing on it, and easily rises up to the rafters. Envelope thickness is found by the following formula which was derived from the equation for a momentless spherical envelope

$$\delta = \frac{nr_{sph}}{2n\mu p}, \quad (6.6)$$

where r_{sph} is the sphere radius in cm; and p is the internal pressure in kg-f/cm². In other words, p must be selected so as to equal the difference between the internal pressure and the envelope weight per unit area of surface. However, the weight per unit area is small and it can be neglected. For example, when the pressure is 0.04 kg-f/cm² and envelope thickness is 0.3 cm, p is 5.8% less; the other quantities in formula (6.6) are also smaller, just as is the case in formula (6.3).

Since the sphere's envelope is thin, we can use Hekkeler's approximation for a spherical envelope to find the edge bending moments around the perimeter and to find the width of the zone in which the edge effect is active. This solution is based on replacing a meridional strip with an infinitely long strip which is tangent to the sphere at the base level in the cross-section. Just as in the case of a cylindrical envelope, we shall consider the strip to be an ideal beam resting on an elastic support. We can write a differential equation for the deflection in the strip in the form

$$D \frac{d^4 w}{dx^4} + \frac{E\delta}{r^2} w = 0.$$

We shall call V the angle of rotation which is tangent to the meridian. Using known differential relationships for deflection from the preceding equation, and letting $dx = r d\phi$, we get

$$\frac{d^2 Q_\phi}{d\phi^2} = E\delta V; \quad (6.7)$$

$$\frac{d^2 V}{d\phi^2} = -\frac{r^2}{D} Q_\phi; \quad (6.8)$$

$$\frac{D}{r} \cdot \frac{dV}{d\phi} = -M_\phi. \quad (6.9)$$

Eliminating V from the first two equations we can get the following differential equation for the strip deflection

$$\frac{d^4 Q_\phi}{d\phi^4} + 4\lambda^4 Q_\phi = 0, \quad (6.10)$$

where

$$\lambda^2 = 3(1 - \mu^2) \left(\frac{r}{b} \right)^2. \quad (6.11)$$

The general solution to this equation takes the form

$$Q_\varphi = e^{\lambda\varphi} (C_1 \cos \lambda\varphi + C_2 \sin \lambda\varphi) + e^{-\lambda\varphi} (C_3 \cos \lambda\varphi + C_4 \sin \lambda\varphi).$$

Since our envelope has no opening in the strip, we need only direct our attention to that term which decreases as the angle ϕ decreases, i.e.

$$Q_\varphi = e^{\lambda\varphi} (C_1 \cos \lambda\varphi + C_2 \sin \lambda\varphi). \quad (6.12)$$

We shall substitute $\psi = \alpha - \phi$ for the angle ϕ and introduce new constants C and γ (fig. 6.2). Then the solution to (6.12) takes the form

$$Q_\varphi = C e^{-\lambda\psi} \sin(\lambda\psi + \gamma). \quad (6.12a)$$

Using expressions (6.7) and (6.9) we get

$$V = \frac{1}{E\delta} \frac{d^2 Q_\varphi}{d\varphi^2} = -\frac{2\lambda^2}{E\delta} C e^{-\lambda\psi} \cos(\lambda\psi + \gamma); \quad (6.13)$$

$$M_\varphi = -\frac{D}{r} \frac{dV}{ds} = \frac{r}{\lambda V^2} C e^{-\lambda\psi} \sin\left(\lambda\psi + \gamma + \frac{\pi}{4}\right). \quad (6.14)$$

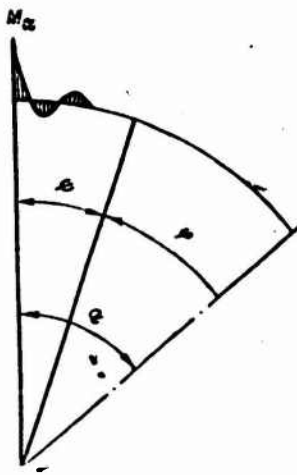

Fig. 6.2. Design diagram for covering the float roof.

Using these differential relationships we get an expression for the horizontal deflection in the following form

$$\Delta = -\frac{r}{E\delta} \sin \varphi \frac{dQ_\varphi}{d\varphi} = -\frac{r}{E\delta} \sin (\alpha - \psi) \lambda \sqrt{2} C e^{-\lambda \psi} \sin \left(\lambda \psi + \gamma - \frac{\pi}{4} \right). \quad (6.15)$$

To find the relationship between the meridional force N_ϕ and the transverse force Q_ϕ , we examine a uniformly loaded, section of the envelope parallel to and below the circle r_0 . Remembering that the load is zero (fig. 6.3) we get

$$2\pi r_0 N_\varphi \sin \varphi + 2\pi r_0 Q_\varphi \cos \varphi = 0,$$

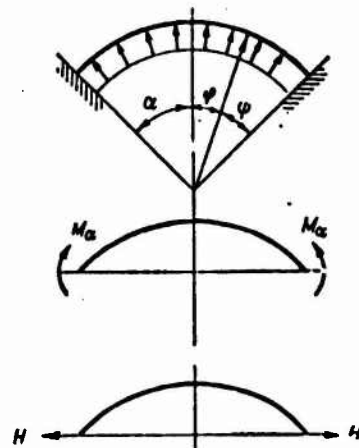
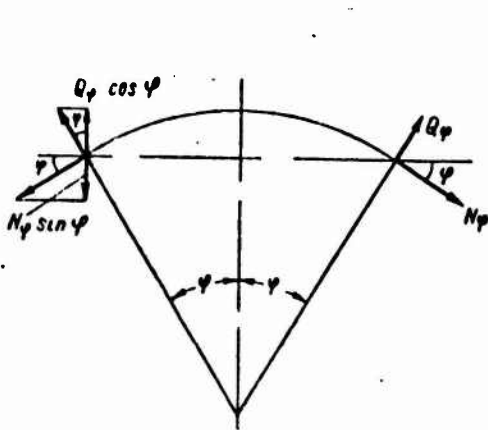

Fig. 6.3. Finding the relationship between N_ϕ and Q_ϕ .

Fig. 6.4. Finding the arbitrary constants C and γ .

whence

$$N_{\varphi} = -Q_{\varphi} \cot \varphi = -\cot(\alpha - \psi) C e^{-\lambda \psi} \sin(\lambda \psi + \gamma). \quad (6.16)$$

We now load the edge of the envelope uniformly ($\phi = \alpha$) with moments M_{ϕ} (fig. 6.4), then the boundary conditions are

$$\begin{aligned} (M_{\varphi})_{\varphi=\alpha} &= M_{\alpha}; \\ (N_{\varphi})_{\varphi=\alpha} &= 0. \end{aligned}$$

From equation (6.16) we get $\gamma = 0$. Setting $\gamma = 0$ and $\psi = 0$ in equation (6.14) we get

$$M_{\alpha} = \frac{r}{2\lambda} C$$

or

$$C = \frac{M_{\alpha}}{r} 2\lambda.$$

Setting the values for the arbitrary constants γ and C into expressions (6.13) and (6.15) we can find the amount of turning and the horizontal displacement in the envelope edge by

$$\begin{aligned} (V)_{\psi=0} &= -\frac{4\lambda^3 M_{\alpha}}{Er\delta}, \\ (\Delta)_{\psi=0} &= \frac{2\lambda^2 \sin \alpha}{E\delta} M_{\alpha}. \end{aligned} \quad (6.17)$$

Now we shall apply a uniformly distributed horizontal thrust load along the edge H (see fig. 6.4). Now the boundary conditions

are

$$\begin{aligned}(M_\varphi)_{\varphi=\alpha} &= 0, \\ (N_\varphi)_{\varphi=\alpha} &= -H \cos \alpha.\end{aligned}$$

From equation (6.14) we find that $\gamma = -\pi/4$. Setting this into (6.16) we get

$$C = -\frac{2H \sin \alpha}{\sqrt{2}}.$$

We put this into expressions (6.13) and (6.15). Then the amount of turning and the horizontal displacement in the envelope edge become

(6.18)

$$\begin{aligned}(V)_{\varphi=0} &= \frac{2\lambda^2 \sin \alpha}{E\delta} H; \\ (\Delta)_{\varphi=0} &= -\frac{2r\lambda \sin^2 \alpha}{E\delta} H.\end{aligned}$$

Now we shall examine our envelope covering the float. We shall assume that the edges are fixed. First we shall look at the momentless problem. The following tensile forces are created when the internal pressure is applied uniformly

$$N_\varphi = N_\theta = \frac{pr}{2}.$$

Here, the envelope edge will not turn and according to Hooke's law the horizontal displacement will be

$$\Delta = \frac{r \sin \alpha}{E\delta} (N_\theta - \mu N_\varphi) = \frac{pr^2(1-\mu)}{2E\delta} \sin \alpha. \quad (6.19)$$

We next apply a force H equally distributed along the perimeter and a moment M_α to the edge of the envelope. The forces and moments must move the edge horizontally in the same amount and direction as in (6.19). The corresponding turning value must be zero. Thus, from (6.17) and (6.18) we get

$$-\frac{4\lambda^3}{Er\delta} M_\alpha + \frac{2\lambda^3 \sin \alpha}{E\delta} H = 0;$$

$$\frac{2\lambda^3 \sin \alpha}{E\delta} M_\alpha - \frac{2r\lambda \sin^3 \alpha}{E\delta} H = -\frac{pr^3(1-\mu)}{2E\delta} \sin \alpha.$$

Solving these equations we finally get

$$M_\alpha = \frac{pr^3(1-\mu)}{4\lambda^3}; \tag{6.20}$$

$$H = \frac{pr(1-\mu)}{2\lambda \sin \alpha}.$$

The stress on the envelope edge will be

$$\sigma = \frac{N_\varphi}{\delta} \pm \frac{M_\alpha}{W} = \frac{H \cos \alpha}{\delta} \pm \frac{GM_\alpha}{\delta^3}. \tag{6.21}$$

In this case the stiffening ring is subject to a distributed load H and bending moments which arise from reactions in the truss legs. The ring rotation due to the fact that the force H is applied eccentrically and passes through the center of gravity can be neglected, since the stiffening ring is connected to the truss legs. We shall cover the ring design later on, when we examine how the roof behaves under its own weight and when subjected to a snow load.

It must be noted that the method we propose to use in designing the roof cover may be used only for very thin coverings and where the rise angle for the spherical surface is approximately 16° (in our case $(r/\delta) \approx (1.1 \text{ to } 1.5)10^4$). When $(r/\delta) < 10^3$ this method creates significant errors.

We shall also examine the second case when there is no excess pressure in the gas tank and the float roof sees its own weight plus a snow load. The cover framework is designed on the assumption that the connection tie points are hinged as in a truss design. This assumption is correct because the frame actually is a system with a fixed geometry.

ω_m - area of the belt m ;

p - a constant load on 1 m^2 projected onto the roof and which consists of the frame weight and the covering ($p = n_3 p_{\text{tot}}$);

$P_m = p \omega_m$ - the constant load on belt m ;

q - total load on 1 m^2 projected onto the roof and which is made up of a constant load and a snow load ($q = p + n_5 q_s$);

$Q_m = q \omega_m$ - total load on belt m ;

k - number of truss legs;

b_m - width of belt m ;

a_m - length of the edge of the horizontal ring in belt m ;

D_m - axial force in the truss leg in belt m ;

T_m - axial force in the horizontal ring m ;

N_m - axial force in the diagonal belt m ;

α_m - tie angle inclination of m in the truss leg;

β_m - angle subtended by the truss leg and the diagonal in belt m ;

n_3 and n_5 - respective transfer coefficients for the weight and snow load.

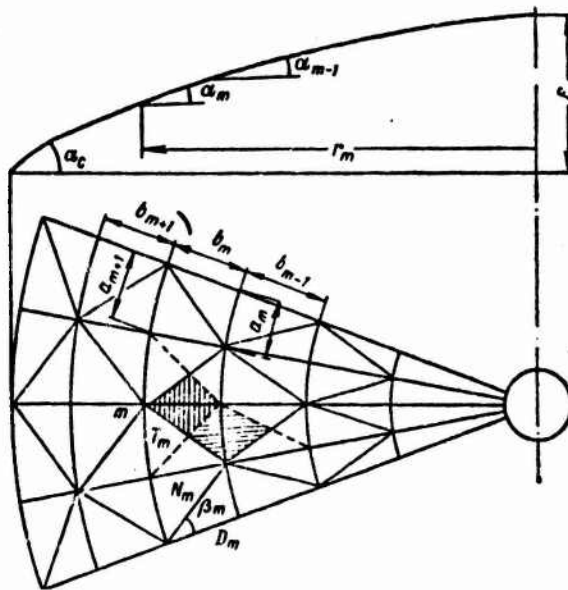

Fig. 6.5. Design diagram for the float roof frame.

The largest compressive force in the truss leg in belt m is caused by the total load and can be found by simply summing all reactions at point m when in equilibrium (fig. 6.6). Removing a portion of the frame belts and setting the reactions from the removed sections equal to

$$\sum_{i=1}^m Q_i/k,$$

we get

(6.22)

$$D_m = \frac{\sum_{i=1}^m Q_i}{k \sin \alpha_m}.$$

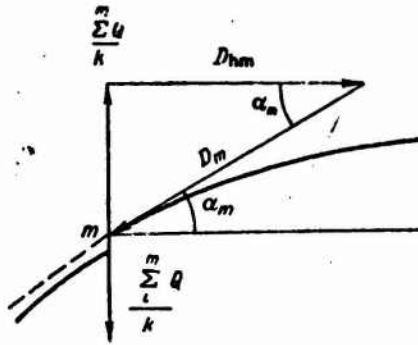

Fig. 6.6. Design diagram for the float roof frame.

Because the force D_m is compressive, we indicate that its direction is toward the joint. Besides compression the section in the truss leg of belt m is deflected because of the total load distributed along the element. This load is proportional to the hatched area in fig. 6.5 and is equal to

$$S_{D_m} = \frac{1}{4} (a_{m+1} + a_m) b_m q.$$

The bending moment can be found by considering this to be a freely supported beam subjected to a triangular load

$$M_{D_m}^{\max} = \frac{S_{D_m} b}{6}.$$

Thus the total stress on the truss leg section can be written as

$$\sigma_{D_m} = \frac{D_m}{F\phi} + \frac{M_{D_m}^{\max}}{W},$$

where ϕ is a stability safety factor for compression.

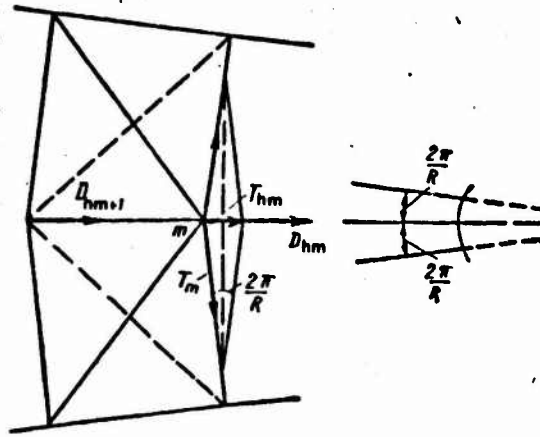

Fig. 6.7. Forces acting at point m.

The force triangles at each point are linked by horizontal tensile forces D_{hm} (see fig. 6.6); T_{hm} , the difference between them at adjacent points, is taken up by the horizontal rings. The maximum tensile force will arise in the ring when that part of the roof within the ring is subjected to a full load, while the section outside the ring only sees a constant load. We get for point m (fig. 6.7)

$$D_{hm} = \frac{\sum_{l=1}^m Q_l}{k} \cot \alpha_m;$$

$$D_{h(m+1)} = \frac{\sum_{l=1}^m Q_l + P_{m+1}}{k} \cot \alpha_{m+1}.$$

Forces transmitted to the ring are found by

$$T_{hm} = D_{hm} - D_{h(m+1)} = \frac{\left(\sum_{l=1}^m Q_l \right) \cot \alpha_m - \left(\sum_{l=1}^m Q_l + P_{m+1} \right) \cot \alpha_{m+1}}{k}.$$

Then the maximum tensile force in the ring is

$$T_m^{\max} = \frac{\left(\sum_{i=1}^m Q_i \right) \cot \alpha_m - \left(\sum_{i=1}^m Q_i + P_{m+1} \right) \cot \alpha_{m+1}}{2k \sin \frac{\pi}{k}} \quad (6.23)$$

In similar fashion it can be shown that if belt $m + 1$ is subject to a total load and the load within the ring is constant, then the latter will be in compression. The compressive forces in the ring in this case can be found from the expression

$$T_m^{\min} = \frac{\left(\sum_{i=1}^m P_i \right) \cot \alpha_m - \left(\sum_{i=1}^m P_i + Q_{m+1} \right) \cot \alpha_{m+1}}{2k \sin \frac{\pi}{k}} \quad (6.24)$$

The central ring is subjected to compression due to the total load on the first roof belt

$$T_1 = \frac{Q_1 \cot \alpha_1}{2k \sin \frac{\pi}{k}} \quad (6.25)$$

Horizontal ring sections in belt m are also deflected because of the distributed load

$$S_{T_m} = \frac{1}{4} (b_m + b_{m-1}) c_m q.$$

The bending moment, as in the case of the truss leg, is

$$M_{T_m}^{\max} = \frac{S_{T_m} a_m}{6},$$

whence the stress in the ring is

$$\sigma_{T_m}^{\max} = \frac{T_m^{\max}}{F} + \frac{M_{T_m}^{\max}}{W};$$

$$\sigma_{T_m}^{\min} = \frac{T_m^{\min}}{F\varphi} + \frac{M_{T_m}^{\max}}{W}.$$

The truss stiffening ring sees tension and is deflected when a total load acts on the roof due to concentrated horizontal forces

$$T_a = \frac{\left(\sum_{i=1}^{\alpha} Q_i \right) \cot \alpha_a}{k}, \quad (6.26)$$

where $\sum_{i=1}^{\alpha} Q_i$ is the total load on the entire roof; and α_a is the inclination angle for the last point.

The diagonals do no work if there is a uniformly distributed load over the entire roof. They see tensile forces when a total load acts on one half of the roof up to that point where a plane passes through the center of the diagonal and there is a constant load on the other half. This force for belt m is

$$N_m = \frac{\sum_{i=1}^m Q_i - \sum_{i=1}^m P_i}{2k \sin \alpha_m \cos \beta_m}. \quad (6.27)$$

Based on what has been described above, we can conclude that both the loads and forces acting on all belt elements are proportional to the area of these belts. Thus in preparing the geometry

diagram where the fullest use is made of construction section properties, the belt width will vary, depending on the distance from the periphery to the center.

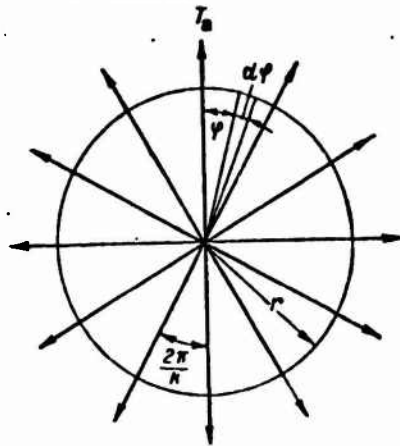

Fig. 6.8. Design diagram for finding the forces in horizontal rings in a float cover frame.

To find the normal and shearing forces and bending moments which arise in a truss ring due to the horizontal thrust from trusses, T_a , (fig. 6.8), we shall use the following differential equation for a curved axis taken from circular ring theory:

$$\begin{aligned} \frac{dN}{ds} - \frac{Q}{r} + q_x &= 0, \\ \frac{dQ}{ds} + \frac{N}{r} + q_y &= 0, \\ \frac{dM_z}{ds} - Q &= 0, \end{aligned} \tag{6.28}$$

where N is the normal force in any normal ring section; Q is the shearing force directed along the ring radius; M_z is the bending moment in a section taken relative to this axis which is perpendicular to the ring's plane; q_x and q_y is a distributed load on the ring directed along the radius and perpendicular to its plane; in our case $q_x = q_y = 0$, and ds is an element of the ring edge where

$$ds = r d\phi$$

and r is the ring radius.

Remembering our remarks, we can derive the following relationships from equations (6.28)

(6.29)

$$\begin{aligned} N &= \frac{dQ}{d\varphi}, \\ Q &= \frac{1}{r} \cdot \frac{dM}{d\varphi}, \\ \frac{d^2Q}{d\varphi^2} + Q &= 0. \end{aligned}$$

The general solution to the last equation is

$$Q = C_1 \cos \varphi + C_2 \sin \varphi. \quad (6.30)$$

To find the arbitrary constants we use the following boundary conditions:

(6.30a)

when $\varphi = 0 \quad Q = T_0/2$

when $\varphi = 2\pi/k \quad Q = -T_0/2,$

where k is the number of truss legs.

Setting the boundary conditions into (6.30) and designating an angle

$$\frac{1}{2} \cdot \frac{2\pi}{k} = \theta,$$

we get

$$\begin{aligned} C_1 &= T_0/2, \\ C_2 &= -(T_0/2) \cot \theta. \end{aligned}$$

Then we find Q

$$Q = \frac{T_0}{2} \cdot \frac{\sin(\theta - \varphi)}{\sin \theta}. \quad (6.31)$$

The normal force is found from the first equation (6.29)

$$N = -\frac{dQ}{d\varphi} = \frac{T_0}{2} \cdot \frac{\cos(\theta - \varphi)}{\sin \theta} \quad (6.32)$$

From the second (6.29) we get

$$\frac{dM_z}{d\varphi} = rQ = \frac{T_0 r}{2} \cdot \frac{\sin(\theta - \varphi)}{\sin \theta},$$

whence

$$M_z = \frac{T_0 r}{2 \sin \theta} \int \sin(\theta - \varphi) d\varphi + C = \frac{T_0 r}{2} \cdot \frac{\cos(\theta - \varphi)}{\sin \theta} + C. \quad (6.33)$$

The closed circular ring is a statically indeterminate system. Therefore, to find the arbitrary constant C, we shall use the Maxwell - Moore method for a ring section where the angle is $\theta = \pi/k$ (Fig. 6.9). At the beginning of the section $\psi = (\theta - \phi) = 0$ and the acting forces are

$$N = \frac{T_0}{2 \sin \theta} \quad (6.34)$$

and the bending moment is M_0 . The shearing force is $Q = 0$. The bending moment in section m - n is

$$M = M_0 - Nr(1 - \cos \psi).$$

The unit moment is $\bar{M} = 1$.

By symmetry when $\psi = 0$, the section angle of rotation is $D_{1T} = 0$. Then

$$\Delta_{1T} = 0 = \int_0^{\theta} \frac{M\bar{M}}{EI} r d\psi = \frac{r}{EI} \left[M_0\psi - \frac{T_0 r}{2} (\psi - \sin \psi) \right]_0^{\theta},$$

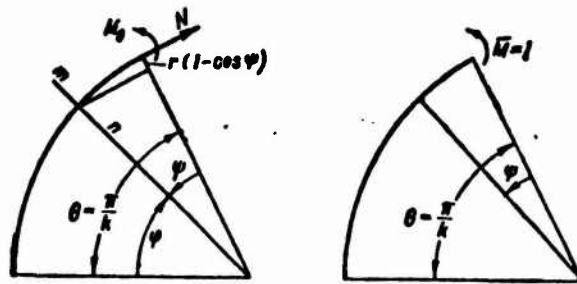

Fig. 6.9. Design diagram for a truss ring section

then we set the limits in and put everything equal to zero.

$$M_0 = \frac{T_a r}{2} \left(\frac{1}{\sin \theta} - \frac{1}{\theta} \right). \quad (6.35)$$

We then put the values for M_0 and ($\phi = \theta$) into equation (6.35)

$$\frac{T_a r}{2} \left(\frac{1}{\sin \theta} - \frac{1}{\theta} \right) = \frac{T_a r}{2} \cdot \frac{1}{\sin \theta} + C; \quad C = -\frac{T_a r}{2\theta}$$

The bending moment in any section is

$$M = \frac{T_a r}{2} \left[\frac{\cos(\theta - \phi)}{\sin \theta} - \frac{1}{\theta} \right]. \quad (6.36)$$

With the last expression we can find the bending moment at the point where T_a is applied and in the center of the span. The corresponding moments will be

$$M_T = \frac{T_a r}{2} \left(\cot \theta - \frac{1}{\theta} \right). \quad (6.36a)$$

$$M_0 = \frac{T_0 r}{2} \left(\frac{1}{\sin \theta} - \frac{1}{\theta} \right). \quad (6.36b)$$

Using the results from (6.36) we find the truss reactions due to ring compression when the roof is subjected to internal pressure during operation (the first load condition). To find these reactions, we shall develop an equation for reconciling truss ring and truss leg deformation at the common point of connection

$$\Delta_X^R - \Delta_H^R = \Delta_X^{tru}, \quad (6.37)$$

where Δ_X^R is the ring deflection caused by an unknown reaction X; Δ_H^R is the radial shift in the ring due to the distributed thrust H; Δ_X^{tru} is the compression in the truss legs because of reaction X. The minus sign appears in the left section because X and H act in opposite directions.

The radial shift in the ring due to the thrust H is made up of

$$\Delta_H^R = \frac{Hr^2}{EF_R}, \quad (6.38)$$

where r is the radius of the ring's circular axis and F_R is the ring's cross sectional area.

We shall find the deflection in the ring due to reaction X using the Maxwell - Moore integral and equation (6.36). The unit moment due to the reaction is $\bar{X}/2 = 1$

$$\bar{M} = r \left[\frac{\cos(\theta - \varphi)}{\sin \theta} - \frac{1}{\theta} \right]. \quad (6.38a)$$

Then the deflection Δ_X^R is found by

(6.39)

$$\Delta_X^R = \frac{1}{EI_R} \int_0^l \frac{Xr}{2} \left[\frac{\cos(\theta - \varphi)}{\sin \theta} - \frac{1}{\theta} \right] \cdot \left[\frac{\cos(\theta - \varphi)}{\sin \theta} - \frac{1}{\theta} \right] r ds =$$

$$= \frac{Xr^3}{2EI_R} \left[\frac{1}{2 \sin^2 \theta} (\theta + \sin \theta \cos \theta) + \frac{1}{\theta} \right],$$

where I_R is the ring section's moment of inertia.

Assuming that the length of the truss leg is approximately $l = r$, and knowing that it only sees compression, we get

$$\Delta_X^{tru} = \frac{Xr}{EF_{tru}}, \quad (6.40)$$

where F_{tru} is the cross-sectional area of the truss leg.

Setting (6.38), (6.39) and (6.40) into (6.37) we finally get

$$X = \frac{2Hr}{r^2 F_{tru} K - 2I_R} \cdot \frac{I_R F_{tru}}{F_R}, \quad (6.41)$$

where

$$K = \frac{1}{2 \sin^2 \theta} (\theta + \sin \theta \cos \theta) - \frac{1}{\theta}.$$

§ 4. Vertical Track Design

In designing tracks, gas tank loading is a function of the uppermost position of moveable sections. This load consists of

the summed pressures against the float and telescopic sections, and a snow load covering half the float on the lee side (fig. 6.10).

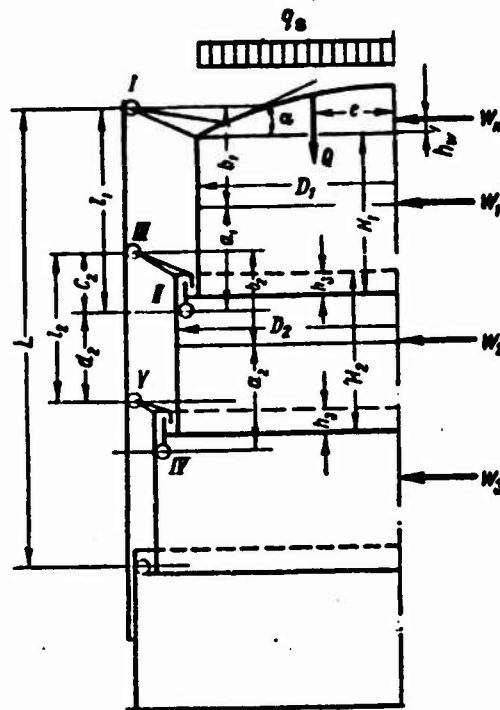

Fig. 6.10. To find roller pressure

The snow load can be written as

$$Q = \frac{1}{2} \cdot \frac{\pi D_1^2}{4} q_s n_s,$$

where D_1 is the float diameter; q_s is the normalized snow load; n_s is the transfer coefficient.

The point at which a uniform snow load is applied is the center of gravity of the roof's horizontally projected area

$$e = 0.212 D_1.$$

The wind load on the float roof can be approximated by the formula

$$W_R = n_w n_w k_a r_{sph} \left(\frac{\alpha \pi}{180} - \sin \alpha \cos \alpha \right) \quad (6.42)$$

where q_w is the normalized wind velocity pressure; n_6 is the transfer coefficient; α is the inclination angle of the tangent to the meridian line at the point where the roof is attached to the truss ring; k_a is the flow coefficient around the spherical surface ($k_a = 0.6$).

The point for applying the uniform force W_R is the center of gravity of the vertical projection of the roof when $\alpha = 16^\circ$

$$h_W = \frac{1}{3.2} f,$$

where f is the roof volume indicator.

The wind load on the float wall is

$$W_1 = n_6 q_w k_a D_1 (H_1 - h_3),$$

where h_3 is the hydraulic seal height; and $k_a = 0.7$ for a cylindrical surface. The point at which the uniformly distributed wind load is applied is

$$h_1 = (H_1 - h_3) / 2$$

The wind load for all subsequent moveable sections is found by

$$W_2 = n_6 q_w k_a D_2 (H_2 - h_3);$$

$$h_2 = \frac{H_2 - h_3}{2} \text{ etc.}$$

Thus, the loads transmitted by the rollers to the tracks are defined. We shall now examine the question of how the loads are distributed between internal and external rollers.

The snow load pressure on the upper float rollers is

$$P_1^s = \frac{Qe}{L}$$

The approximation can be made that the point of applying the uniformly distributed wind load on the roof lies in a plane which contains the axes of the upper rollers, and therefore, roller pressure will be

$$P_1^w = W_R$$

Roller pressure on the float wall due to wind load is

$$P_1^{ww} = \frac{W_1 a_1}{l_1}$$

The combined pressures on the float's upper rollers is

$$P_1 = P_1^s + P_1^w + P_1^{ww}$$

The float's lower rollers see only a wind load

$$P_{II} = \frac{W_1 b_1}{l_1}$$

Part of the pressure on the telescopic section upper rollers is due to the wind load on the wall and the pressures on the float's lower rollers are due to:

wind load

$$P_{III}^w = \frac{W_1 d_1}{l_2}$$

pressure on the float's lower rollers

$$P_{III}^r = \frac{F_{II} d_2}{l_2}$$

The combined pressures on the telescopic section upper rollers are

$$P_{III} = P'_{III} + P''_{III}.$$

The pressures on the telescopic section lower rollers are:

wind load

$$P'_{IV} = \frac{W_3 b_3}{l_3};$$

pressure on the float's lower rollers

$$P''_{IV} = \frac{P_{II} c_2}{l_3};$$

total pressure on the telescope's lower rollers

$$P_{IV} = P'_{IV} + P''_{IV}.$$

In similar fashion, the pressure can be determined for the upper and lower rollers in the rest of the telescopic sections.

We shall now find the maximum pressure in one roller. The external load is received by the rollers on the lee side of the gas tank. The pressure due to the external load reaches a maximum at point A (Fig. 6.11) and is zero at points B and B₁. Designating the pressure at point A by S₀, we find that the radial pressure at any point in the semicircle is

$$S = S_0 \cos \varphi.$$

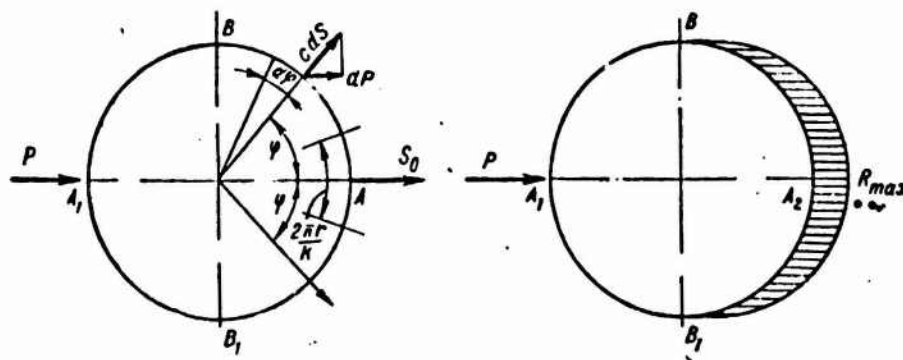

Fig. 6.11. To find the maximum pressure on one roller.

The pressure acting on an infinitely small element of the arc corresponding to the angle $d\phi$ is

$$dS = S r d\phi = S_0 r \cos \phi d\phi.$$

The projection of this pressure in the direction of the load is

$$dP = dS \cos \phi = S_0 r \cos^2 \phi d\phi.$$

Thus, the full pressure on a semicircle is

$$P = 2 \int_0^{\pi/2} S_0 r \cos^2 \phi d\phi = \frac{\pi S_0 r}{2}$$

or

$$S_0 = \frac{2P}{\pi r}.$$

(6.43)

Roller pressure at point A is

$$R_{\max} = S_0 \frac{\pi r}{n/2} = S_0 \frac{2\pi r}{n},$$

where n is the number of tracks

Substituting the value of S_0 from (6.43), we get

$$R_{\max} = \frac{4P}{n}.$$

(6.44)

Thus, the maximum pressure on one roller equals one fourth of the combined pressure for all rollers in a specified row, divided by the number of tracks.

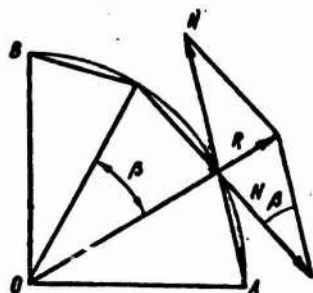

Fig. 6.12. Forces in the horizontal rings in a track system.

The horizontal rings in the track system see the track pressure as an external load and this creates tensile forces in them. These forces can be determined by resolving the radial pressure into two adjoining ring edges (Fig. 6.12) so that $N = R/2 \sin (\beta/2)$,

where

$$\beta = 2\pi/n.$$

The maximum tensile force in the ring is

$$N^{\max} = \frac{R_{\max}}{2 \sin (\beta/2)}. \quad (6.45)$$

In addition to the axial tensile forces, a bending moment due to the weight and other random forces acts on the ring's edge where

$$M = \frac{q \ell^2}{8} b,$$

where ℓ is the length of the ring's edge; b is the ring width; and q is the equally distributed total load.

For those rings which also serve as gas tank inspection areas, $q = 200 \text{ kg-f/m}^2$ for intermediate rings. The stress in the ring is

$$\sigma = \frac{N^{\max}}{F} \pm \frac{M}{W}.$$

Roller radial pressure varies from point to point and because of this, forces in the horizontal rings vary. Therefore, we will always have a difference between forces, N , in two adjacent ring points. Assuming that these forces in adjacent points are N_1 and N_2 (Fig. 6.13) we have

$$H = N_1 - N_2$$

or substituting for N ,

$$H = \frac{R_1 - R_2}{2 \sin(\beta/2)}.$$

R_1 and R_2 can be derived from R_{\max} , knowing that

$$\begin{aligned} R_1 &= R_{\max} \cos \varphi, \\ R_2 &= R_{\max} \cos(\varphi + \beta), \\ H &= \frac{R_{\max} [\cos \varphi - \cos(\varphi + \beta)]}{2 \sin(\beta/2)} = R_{\max} \sin \alpha, \end{aligned}$$

(6.46)

where $\alpha = \varphi + (\beta/2)$.

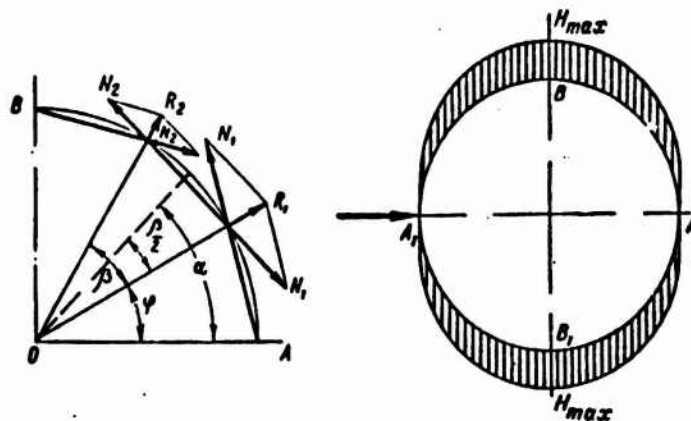

Fig. 6.13. Forces which act on the diagonal and vertical struts in track panels.

The maximum values for H will occur at those points where $\alpha = 90^\circ$ and -90° . Therefore, the force H occurs not only in the lee side but throughout the entire ring. We found $R_{\max} = 4P/n$ by intergrating over the semicircular ring. The entire circle must be integrated to find H_{\max} . In this case

$$H_{\max} = (2/n)P.$$

Curves showing how R and H change around the ring are shown in figs. 6.11 and 6.13.

If we divide the entire system in separate planar trusses and load them with force H (Fig. 6.14), and lay out the forces in the truss plane, we can find the forces in the vertical struts and in the diagonals.

The force in the diagonals is

$$D_1 = \frac{H_1}{\cos \varphi_1} = \frac{2P_1}{n \cos \varphi_1}.$$

The force in the vertical strut, 1, is

$$V_1 = -D_1 \sin \varphi_1 = -\frac{2}{n} P_1 \tan \varphi_1.$$

The force at point 2 will be made up of forces H_1 and H_2 . Then for diagonal at 2 we get

$$D_2 = \frac{H_1 + H_2}{\cos \varphi_2} = \frac{2}{n \cos \varphi_2} (P_1 + P_{III})$$

and for the vertical strut at 2 we get

$$\begin{aligned} V_2 &= -D_2 \sin \varphi_2 = \\ &= -\frac{2}{n} \tan \varphi_2 (P_1 + P_{III}). \end{aligned}$$

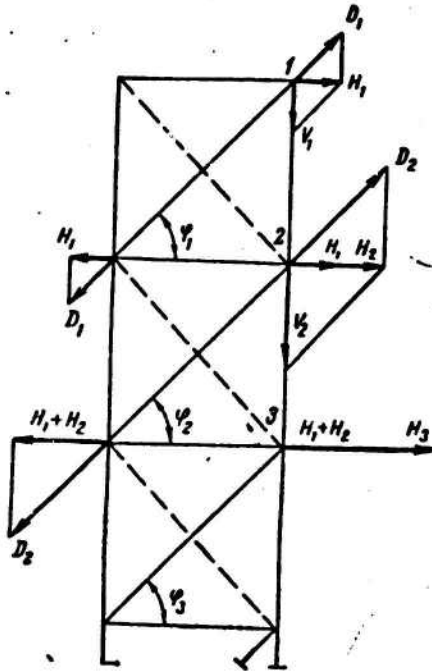

Fig. 6.14. Design diagram for diagonal and vertical struts.

The forces in the rest of the struts and in the diagonals in other plane panels can be found in similar fashion.

It is possible to get a condition while operating the gas tank where the float is elevated entirely but the telescopic section is not up fully. Then the float roller can fall in between the vertical strut and horizontal rings and this pressure on the strut creates the bending moment

$$M_{\max} = R_{\max} h/4,$$

where h is the height of the strut section.

Therefore, the bending moment must be used to find the bending

$$\sigma = \pm \frac{M_{\max}}{W} - \frac{V}{F\phi} \leq mR,$$

where ϕ is the stability reserve factor and R is the design load.

The internal telescopic section and storage tank tracks can be viewed as beams supported at two points and loaded at the center point of the span. In this case the bending moment is

$$M = Rl/4,$$

where l is the free track length.

Assuming track width as b_R and telescopic section height as H_T ,

$$l = H_T - 2 \frac{b_R}{2} = H_T - b_R;$$

the maximum roller pressure is

$$R_{in}^{max} = \frac{4P}{n_{in}},$$

where n_{in} is the number of internal rollers. Usually they are twice as numerous as the external tracks, i.e., $n_{in} = 2n$.

A value for P can be found in the same way as for the external tracks. The only difference is that only half the height of the section above is used in calculating the total wind load W . This is because the maximum bending moment in the track is in the center of the span l .

§ 5. Helical Track Design

The external, horizontal or vertical, asymmetrical load acting on a moveable section of a helical type gas storage tank is transmitted by the tracks to the rollers and they create a horizontal reaction tangent to the circular surface at the points where the rollers touch the tracks. In addition, the asymmetrical, external load creates an overturning moment with respect to the BB_1 ,

axis which is perpendicular to the load's line of action and which lies in the roller plane. This moment is equal to the moment created in the rollers by the vertical reactions relative to this same axis. Roller reaction can only be transmitted normal to the track; therefore, both reactions, horizontal and vertical, are made up of normal reactions. In this case the external load is picked off the vertical tracks by all rollers, whether on the windward or lee sides (fig. 6.15).

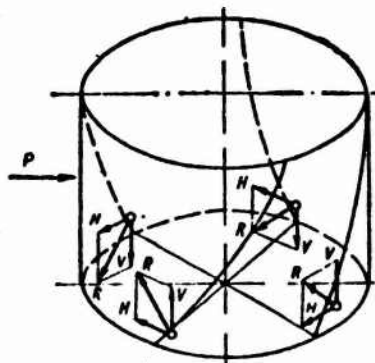

Fig. 6.15. To find helical track reactions.

It can be seen in Fig. 6.16 that the maximum horizontal reactions will occur at points B and B₁ and they vary proportionately with $\sin \phi$. We shall assume that the pressure is uniformly distributed around the surface and the pressure at points B and B₁ shall be designated as S_0 . Then at any point

$$S = S_0 \sin \phi.$$

The pressure acting on an infinitely small arc element $r d\phi$ is

$$dS = S r d\phi = S_0 r \sin \phi d\phi.$$

The corresponding projection in the direction of the external load is

$$dP = S_0 r \sin^2 \phi d\phi.$$

Total pressure around the entire periphery is

$$P = 4 \int_0^{\pi/4} S_0 r \sin^2 \phi \, d\phi = 4S_0 r (\pi/4),$$

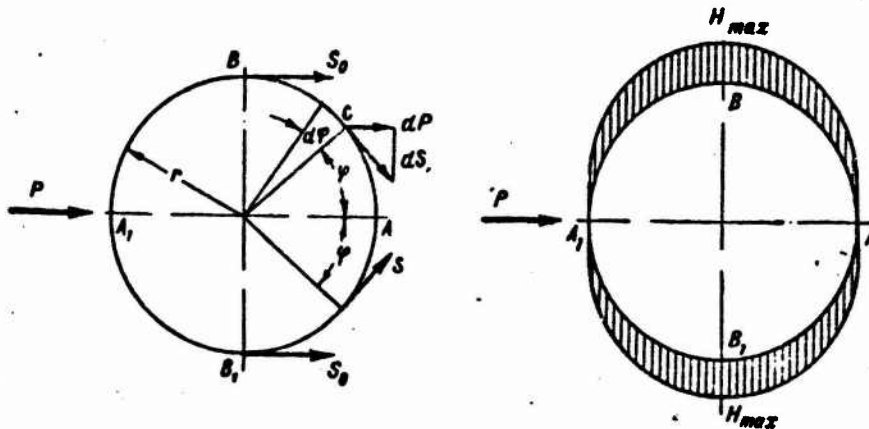

Fig. 6.16. To find the maximum horizontal reaction.

whence

$$S_0 = P/\pi r. \quad (6.47)$$

On the other hand, the maximum horizontal reaction at one roller is

$$H_{max} = S_0 \frac{2\pi r}{n}. \quad (6.48)$$

Substituting S_0 into (6.48), we get

$$H_{max} = 2P/n, \quad (6.49)$$

where n is the number of tracks.

Since the pressure S is proportional to $\sin \phi$, then the horizontal reaction at the intervening rollers is

$$H = 2P/n \sin \phi. \quad (6.49a)$$

We compute the vertical pressure S_V in the same way. In comparison to the horizontal, this will be proportional to $\cos \phi$. Thus, it will reach a maximum, S_{V0} , at points A and A_1

$$S_V = S_{V_0} \cos \phi.$$

The pressure on an edge element is

$$dS_V = S_V r d\phi = S_{V_0} r \cos \phi d\phi.$$

This pressure creates the elementary moment with respect to the BB_1 axis

$$dM = dS_V r \cos \phi = S_{V_0} r^2 \cos^2 \phi d\phi.$$

Then the moment is

$$M = 4 \int_0^{\pi/2} S_{V_0} r^2 \cos^2 \phi d\phi = S_{V_0} \pi r^2$$

or

$$S_{V_0} = M / \pi r^2. \quad (6.50)$$

The maximum, vertical, roller reaction is

$$V_{max} = S_{V_0} (2\pi r / n). \quad (6.51)$$

Substituting the value from (6.50), we get

$$V_{max} = 2M / nr. \quad (6.52)$$

For the intervening rollers

$$V = (2M / nr) \cos \phi, \quad (6.52a)$$

where M equals the overturning moment due to the external forces.

The overturning moment M , just as in the case for vertical tracks, can be written as $M = \Sigma W h$, where ΣW is the combined wind load against the moveable sections located above the row of rollers being examined; h is the height of the point at which the uniform, combined wind load is being applied (at the center of gravity of the plane projected onto the vertical).

Thus, since $\sin 45^\circ = \cos 45^\circ$, the normal reaction at each track will equal that found by expressions (6.49) and (6.52a)

$$R = (H + V) \sin 45^\circ$$

or

$$R = \left(\frac{2P}{n} \sin \varphi + \frac{2M}{nr} \cos \varphi \right) \sin 45^\circ = \frac{2}{n} \left(P \sin \varphi + \frac{M}{r} \cos \varphi \right) \sin 45^\circ. \quad (6.53)$$

We can find the maximum value for R by:

$$\frac{dR}{d\varphi} = \frac{2}{n} \sin 45^\circ \left(P \cos \varphi - \frac{M}{r} \sin \varphi \right), \quad (6.54)$$

$$\frac{d^2R}{d\varphi^2} = -\frac{2}{n} \sin 45^\circ \left(P \sin \varphi + \frac{M}{r} \cos \varphi \right). \quad (6.55)$$

Consequently, from the expression (6.54) for R_{\max} the angle ϕ will be

$$\begin{aligned} P \cos \varphi - (M/r) \sin \varphi &= 0; \\ \tan \varphi &= Pr/M; \\ \varphi &= \arctan (Pr/M). \end{aligned} \quad (6.56)$$

If we make an approximation by setting $h = H/2$ (where H is the height of the moveable section) and $M = Ph$, we get for R_{\max} from expression (6.56)

$$\varphi = \tan^{-1} (r/h). \quad (6.57)$$

For example, if we assume $D/H = 1.6$ for a gas tank, we get

$$\phi_{R_{\max}} = 58^\circ.$$

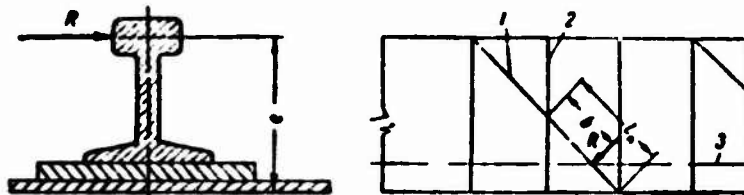

Fig. 6.17. Design diagram for a helical track.

Axes: 1- track; 2- vertical strut; 3- plane locating the axes of all rollers.

Therefore, R_{\max} will appear on the roller pair at an angle of approximately 60° to the load line of action.

Equation (6.57) shows that if the D/H ratio is reduced, $\phi_{R_{\max}}$ approaches 45° and reaches it when $D/H = 1$.

The normal reaction R_{\max} creates a torque at the track $M_{to} = R_{\max} \ell$, where ℓ is the distance from the point where the roller contacts the track to the moveable wall's inside surface (fig. 6.17).

In moving along the track distance between two vertical struts, the torque is

$$M_d = M_{to} (b/l_n),$$

where b is the distance from the contact point to the center of the vertical frame section strut; l_n is the distance between framework struts measured along the track (see Fig. 6.17).

Tangential stresses can be found in strength of materials formulas

At the rail head it is

$$\tau = \frac{M_d h_r}{J_{gy}} \leq m R_{se};$$

At the base

$$\tau = \frac{M_d b_d}{J_{gy}} \leq m R_{se};$$

where h_r is the rail head height; b_d is the combined envelope section thickness for the rail cover plate and base; J_{gy} is the moment of gyration; m is the operating condition factor and R_{se} is the design load through the section.

§ 6. Designing Construction Elements for Dry Type Gas Tanks

A dry type gas tank housing is designed according to a formula developed from the momentless condition of a cylindrical envelope

$$(n_1 p r / \delta \phi) \leq m R,$$

where n_1 is the transfer coefficient ($n_1 = 1, 2$); p is the gas's internal pressure; r is the gas tank housing radius; δ is the wall thickness; ϕ is the weld strength factor; m is the factor for working conditions and R is the design load for steel.

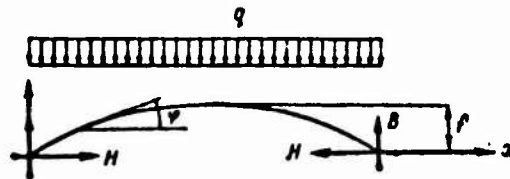

Fig. 6.18. Design diagram for the frame ring in the vertical wall of a dry type gas tank piston.

According to calculations, wall thickness is usually quite small, so a 5 mm thickness is used for construction. An edge effect is created at the point where the wall ties into the base. Calculating the load here is like calculating the load at the low point of a storage tank, except that in this case the external load is not hydrostatic pressure where $p = p(x)$, but a uniform, internal gas pressure where $p = \text{const}$. Dry gas tank covers do not experience a load due to external pressure, therefore the design considers only the cover weight and the snow load, just as in the case of designing roofs for wet type gas tank floats.

We shall examine how a dry type gas tank piston with a flexible section operates. The weight of the construction and the gas pressure are the main loads on the bearing framework, the piston's vertical wall and base. In addition there is a preload on the base framework.

The gas pressure is transmitted through the flexible section into the protective, vertical wall of the piston whose panels are reenforced with support bolts fastened to the framework's ring collar beams. The spacing between the ring collar beams along the vertical is 700-1000 mm. Since the bolts are set up at each ring collar beam-angle equally (at a pitch distance of 500 mm), we may say that the section between the two struts is a double hinged arch with a uniformly distributed load (fig. 6.18). This type of arch, as is known, is a statically indeterminate system; therefore, one of the methods for solving this type of system, such as the Maxwell-Moore method, must be used to find the thrust H against the arch. Assuming that M_0 is the torque and Q_0 the shearing stress in a beam with a straight axis equal to this span, we can write the following expression for the arch:

$$\begin{aligned} M &= M_0 - Hy_0 \\ Q &= Q_0 \cos \varphi - H \sin \varphi. \end{aligned} \tag{6.58}$$

The displacement in the end of the arch consists of a component due to the bending moment M and a component normal to the cross section where the longitudinal force N is applied. Assuming that the arch is sloping gently, we can say that $N \approx H$.

The unit moment from $\bar{H} = 1$ will be $\bar{M} = -y$.

The unit normal force $\bar{N} \approx \bar{H} = 1$.

The actual shift in the end of the arch is zero; therefore, the Maxwell-Moore integral can be written as

$$\Delta = - \int_0^S \frac{(M_0 - Hy)y ds}{EJ_z} + \int_0^S \frac{H ds}{EF} = 0. \quad (6.59)$$

Designating $J_z/F = i^2$, we can write for H

$$H = \frac{\int_0^S M_0 y ds}{\int_0^S y^2 ds + i^2 ds}. \quad (6.60)$$

The second term in the denominator describes the effect of reducing the arch due to axial compression. If we assume arch length to be small, we can ignore this term. Then we get the following expression for H :

$$H = \frac{\int_0^S M_0 y ds}{\int_0^S y^2 ds}. \quad (6.61)$$

Since we considered the arch to be gently sloping, the curved shape can be replaced with a parabolic one

$$y = \frac{4fx(l-x)}{l^2}, \quad (6.62)$$

where f is the arch lift indicator.

The beam rolling method moment is

$$M_0 = (q/2)x(l-x), \quad (6.63)$$

then substituting formulas (6.62) and (6.63) into equation (6.61), we get

$$H = ql^2/8f. \quad (6.64)$$

The thrust obtained by formula (6.64) is an approximation; however, the error in this case is small. Thus, for example, if the piston diameter is 33.4 m and the number of struts in the vertical framework is 16 (the gas tank capacity is 10,000m³) the error $(\Delta H/H)100$ is less than 2.3%.

The radial beams in the bottom of the frame can be regarded as beams with a span equal to the piston diameter, resting on two supports and carrying a load made up of the weight of the beams q_b , the base plate q_{fl} , the gas pressure p acting upward, and the preload weight Q . The load resulting from the base weight and gas pressure is proportional to the area, and it gets smaller as it moves from the perimeter to the center according to the triangle law. The load distribution and bending moments curves are given in Fig. 6.19. Truss reactions, bending moments and transverse forces can be found using the ordinary methods from the strength of materials.

The flexible section of the gas tank works under complex conditions; it is elongated by gas pressure, the piston fabric wears, and there is multiple bending. With these conditions we must also consider the non-homogeneity of materials, the affect of low temperature on the ambient air, and possible deflections

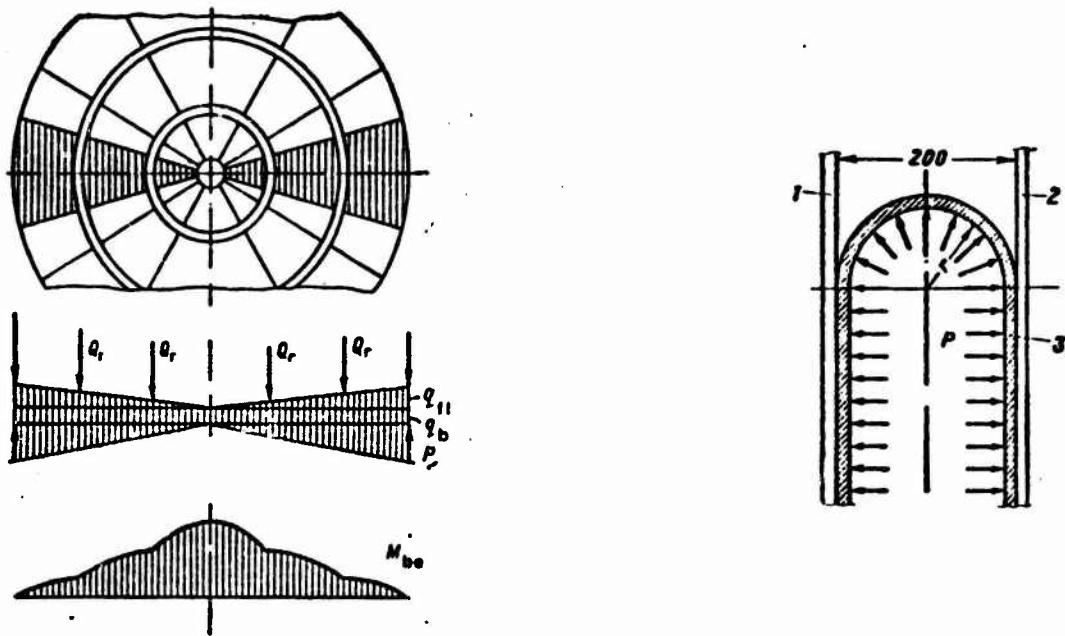

Fig. 6.19. Curves for the distributed load and bending moments.

Fig. 6.20. Design diagram for a flexible section.

in the material thickness along the entire area of the fabric. The design diagram for the flexible section is shown in Fig. 6.20. The stress in the fabric can be found by the formula

$$\sigma = n_1 pr / m \delta,$$

where p is the gas pressure in the gas tank; r is the fabric bend radius (r is made equal to half the annular clearance between the housing wall and the gas tank piston); δ is the fabric thickness ($\delta = 2-3$ mm); n_1 is the transfer coefficient ($n_1 = 5.0$); and m is the working condition factor ($m = 0.1$).

The values for n and m are fixed by the need for high reliability at the flexible section and its complex mode of operation. The strength of the rubberized fabric must be $\sigma > 100$ kg-f/cm². In addition, the fabric must be impermeable to water and gas, chemically stable, and maintain its elasticity at -50°C .

§ 7. The Design of High Pressure, Cylindrical Gas Tanks

The main load in a cylindrical gas tank is the internal gas pressure. In all sizes the length of the cylindrical section of these gas tanks exceeds the envelope diameter several times over, so this makes it possible to design a gas tank housing using momentless theory, keeping in mind, however, the edge effect at the spot where the cylindrical section joins the spherical base.

Circular and longitudinal forces are created within the cylindrical section of the gas tank due to the internal pressure.

The circular forces are

$$N_t = pr; \quad (6.65)$$

The longitudinal are

$$N_x = pr/2. \quad (6.66)$$

The respective stresses corresponding to the forces in (6.65) and (6.66) are

$$\begin{aligned} \sigma_t &= pr/\delta; \\ \sigma_x &= pr/2\delta, \end{aligned} \quad (6.67)$$

where p is the gas pressure; r is the radius of the cylindrical portion of the housing; and δ is the wall thickness.

Strength can be checked by using the energy theory on strength

$$\sqrt{\sigma_t^2 - \sigma_t\sigma_x + \sigma_x^2 + 3\tau_x^2} \leq \frac{m}{n} \varphi \eta R \quad (6.68)$$

or remembering that

$$\sigma_t = 2\sigma_x$$

and

$$\tau_{tz}^{\max} = \frac{\sigma_t - \sigma_z}{2} = \frac{\sigma_r}{2}, \quad (6.69)$$

$$0,97 \frac{pr}{\delta} \leq (m/n) \phi \eta R,$$

where m is the working condition factor ($m = 0.65$); n is the transfer coefficient ($n = 1.15$); ϕ is the joint strength coefficient ($\phi = 1$); η is the correction factor ($\eta = 0.9$); and R is the design load of steel.

If the steel is an off-gauge product, the quantity $c = 0.8$ mm must be added to each calculated wall thickness.

The forces at the spherical bases are

$$N = pr_{\text{sph}}/2, \quad (6.70)$$

where r_{sph} is the radius of the spherical base (usually r_{sph} equals the radius of the cylindrical section).

The stress in the spherical base is

$$\sigma = \frac{pr}{2\delta_{\text{sph}}} \leq (m/n) \phi \eta R. \quad (6.71)$$

The designations in formula (6.71) are the same as in formula (6.70).

The addition to the spherical base thickness is: $c = 0.8$ mm for off-gauge products; $c_1 = 2.8$ for dished.

As has been noted already, an edge effect is created at the point where the cylindrical section housing section and the spherical base join, i.e., stresses arise due to envelope bending. As

a matter of fact, the radial displacement in the cylindrical section walls, according to Hooke's law for a planar stress condition is

$$\Delta^c = (r/E\delta)(N_t - \mu N_r)$$

or substituting formulas (6.65) and (6.66)

(6.72)

$$\Delta^c = \frac{pr^2}{E\delta} \left(1 - \frac{\mu}{2}\right).$$

The radial displacement in the spherical base is

(6.73)

$$\Delta^{sph} = \frac{rN}{E\delta_{sph}} (1 - \mu) = \frac{pr^2}{2E\delta_{sph}} (1 - \mu).$$

Comparing formulas (6.72) and (6.73) we note that there is a break in envelope continuity at the junction point. Therefore, this break must be compensated for by having bending moments M_0 and shearing forces Q_0 uniformly distributed around the perimeter. If in finding M and Q , the housing is considered to be long, we can use the solution (6.5) to equation (6.4) mentioned in § 2 of this chapter; however, for the time being we shall not use the right-hand part of equation (6.4).

In solving (6.5) we get

$$w = e^{-\beta x} (C_3 \cos \beta x + C_4 \sin \beta x).$$

Assuming the coordinate system starts at the junction, and setting up the boundary conditions at this point

$$(M_x)_{x=0} = - \left(D \frac{d^2 w}{dx^2} \right)_{x=0} = M_0; \quad (6.74)$$

$$(Q_x)_{x=0} = - \left(D \frac{d^3 w}{dx^3} \right)_{x=0} = Q_0.$$

we get

$$C_3 = -\frac{1}{\beta^2 D} (Q_0 + \beta M_0), \quad (6.75)$$

$$C_4 = \frac{1}{2\beta^2 D} M_0.$$

Then we get as the final form of the deflection w

$$w = \frac{e^{-\beta x}}{2\beta^2 D} [\beta M_0 (\sin \beta x - \cos \beta x) - Q_0 \cos \beta x]. \quad (6.76)$$

The maximum deflection occurs when $x = 0$

$$(w)_{x=0} = -\frac{1}{2\beta^2 D} (\beta M_0 + Q_0). \quad (6.77)$$

A minus sign appears because deflection toward the cylinder axis is considered to be positive.

The section angle of rotation can be found by the differential equation (6.76)

$$\left(\frac{dw}{dx}\right)_{x=0} = -\frac{1}{2\beta^2 D} (2\beta M_0 + Q_0). \quad (6.78)$$

The same reasoning as above applies to the cylindrical section of the envelope. However, if we consider the edge of the spherical envelope as a part of a long cylinder with the same radius, then we can solve the problem of deflection approximately, using expressions (6.76), (6.77) and (6.78). To do this the δ , β and D must be replaced in the latter with δ_{sph} , β_{sph} and D_{sph} . The error in stress values due to the deflection in thin

envelopes using such an approximation is very small and is less than 1% when $r/\delta > 30$.

To find M_0 and Q_0 , we must use a method taken from structural mechanics, for example, the force method. To do this, we apply the moment $\bar{M} = 1$ and force $\bar{Q} = 1$ at the point and we form canonical equations (fig. 6.21):

$$\begin{aligned} \delta_{11}M_0 + \delta_{12}Q_0 + \Delta_{1P} &= 0; \\ \delta_{21}M_0 + \delta_{22}Q_0 + \Delta_{2P} &= 0, \end{aligned} \tag{6.79}$$

where the unit displacements equal the sum of displacements in the cylindrical and spherical sections, i.e.,

$$\begin{aligned} \delta_{11} &= \delta_{11}^c + \delta_{11}^{sph}, \\ \delta_{12} = \delta_{21} &= \delta_{12}^c + \delta_{12}^{sph}, \\ \delta_{22} &= \delta_{22}^c + \delta_{22}^{sph}, \\ \Delta_{1P} &= \Delta_{1P}^c + \Delta_{1P}^{sph}, \\ \Delta_{2P} &= \Delta_{2P}^c + \Delta_{2P}^{sph} \end{aligned}$$

We find the unit displacements. Setting $Q_0 = 0$ and $M_0 = 1$ into equation (6.78), we get

$$\delta_{11}^c = \frac{1}{\beta D} \text{ is similar to } \delta_{11}^{sph} = \frac{1}{\beta_{sph} D_{sph}};$$

$$\delta_{11} = \frac{1}{\beta D} + \frac{1}{\beta_{sph} D_{sph}}, \tag{6.80a}$$

Setting $M_0 = Q$ and $Q_0 = 1$ into equation (6.77)

$$\begin{aligned} \delta_{12}^c &= \frac{1}{2\beta^2 D}; & \delta_{12}^{sph} &= \frac{1}{2\beta_{sph}^2 l_{sph}}; \\ \delta_{12} &= \frac{1}{2} \left(\frac{1}{\beta^2 D} + \frac{1}{\beta_{sph}^2 l_{sph}} \right). \end{aligned} \quad (6.80b)$$

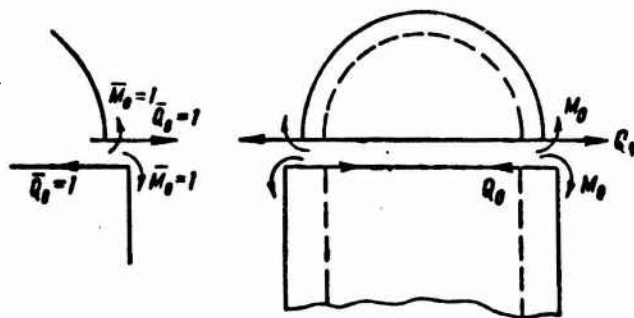

Fig. 6.21. Design diagram for the junction of cylindrical housing with a spherical base.

To find $\delta_{12} = \delta_{21}$ we set $M_0 = 1$ and $Q_0 = 0$ into equation (6.77)

$$\begin{aligned} \delta_{12}^c &= \delta_{21}^c = \frac{1}{2\beta^2 D}; & \delta_{12}^{sph} &= \delta_{21}^{sph} = -\frac{1}{2\beta_{sph}^2 l_{sph}}; \\ \delta_{12} &= \delta_{21} = \frac{1}{2} \left(\frac{1}{\beta^2 D} - \frac{1}{\beta_{sph}^2 l_{sph}} \right). \end{aligned} \quad (6.80c)$$

Since p does not depend on x , it is evident from equation (6.5) that the displacements Δ_{1p} equal zero when rotated through an angle under the action of an external load, i.e.

$$\Delta_{1p}^c = \Delta_{1p}^{sph} = 0.$$

The displacements Δ_{2P} are represented by expressions (6.72) and (6.73).

The sum of the displacements is

$$\Delta_{2P} = \Delta_{2P}^c + \Delta_{2P}^{sph} = \frac{Pr^2}{2E} \left[\frac{1}{\delta} + (1-\mu) \left(\frac{1}{\delta} - \frac{1}{\delta_{sph}} \right) \right] \quad (6.80d)$$

Setting these values for displacements into the canonical equations (6.72), we can find the shearing force Q_0 and the bending moment M_0 . Then the stress near the seam can be found by the formula

$$\sigma = \frac{N_x}{\delta} \pm \frac{6M_x^{\max}}{\delta^2}, \quad (6.81)$$

where M_x^{\max} is found by investigating the equation

$$M_x = -D \frac{d^2w}{dx^2} = -\frac{e^{-\beta x}}{2\beta} [2\beta M_0 (\cos \beta x + \sin \beta x) + 2Q_0 \sin \beta x]. \quad (6.82)$$

The problem of finding M_0 and Q_0 can be simplified considerably if $\delta = \delta_{sph}$ and consequently $D = D_{sph}$, $\beta = \beta_{sph}$. In this case $\delta_{12}^c = \delta_{12}^{sph}$, $\delta_{12} = 0$.

We then find directly from the first canonical equation (6.79) that $M_0 = 0$. Remembering that $\Delta_{2P} = pr/2\delta E$, from the second equation we get

$$\frac{1}{\beta^2 D} Q_0 = \frac{pr^2}{2E\delta},$$

whence

$$Q_0 = \frac{pr^2 \beta^2 D}{2E\delta}$$

or using the values for β and D (see § 2),

$$Q_0 = p/8\beta. \quad (6.83)$$

Now, using the notations for functions with the argument βx introduced in Chapter 4, the expressions for M_x and w can be written in the following form:

$$w = \frac{e^{-2x}}{2\beta^2 D} \cdot \frac{p}{8\beta} \cos \beta x = -\frac{p}{16\beta^4 D} \theta(\beta x); \quad (6.84)$$

$$M_x = -\frac{e^{-2x}}{\beta} \cdot \frac{p}{8\beta} \sin \beta x = -\frac{p}{8\beta^3} \zeta(\beta x). \quad (6.85)$$

Substituting in the values for β , we get

$$M_x = -\frac{pr\delta}{8\sqrt{3(1-\mu^2)}} \zeta(\beta x). \quad (6.86)$$

Taking the derivative of expression (6.82) and setting it equal to zero, we find that M_{\max} at its absolute value corresponds to $x = \pi/4\beta$, therefore

$$M_x^{\max} = \frac{pr\delta}{8\sqrt{3(1-\mu^2)}} \zeta\left(\frac{\pi}{4}\right)$$

and the combined, maximum stress is

$$\sigma_x^{\max} = \frac{pr}{2\delta} \left[1 + \frac{3}{2} \cdot \frac{1}{\sqrt{3(1-\mu^2)}} \zeta\left(\frac{\pi}{4}\right) \right] \quad (6.87)$$

Finding the value for $\zeta(\pi/4)$ from a table and taking the μ

for steel as 0.3, the formula (6.87) can be written as

$$\sigma_t^{\max} = 1.293 (pr/\delta), \quad (6.87a)$$

i.e., the longitudinal stresses on the envelope's inside surface are about 30% higher than the stresses computed without taking deflection into account.

When calculating the circular stresses, we must consider the circular bending moment $M_t = \mu M_x$ and the circular forces caused by the deflection $N = -(E\delta/r)w$.

The circular stresses are

$$\sigma_t = \frac{pr}{\delta} - \frac{Ew}{r} - \frac{6M_x}{\delta^2} \mu = \frac{pr}{\delta} \left[1 - \frac{1}{4} \theta(\beta x) + \frac{3\mu}{4\sqrt{3}(1-\mu^2)} \zeta(\beta x) \right]. \quad (6.88)$$

Using tables for $\theta(\beta x)$ and $\zeta(\beta x)$ and taking $\mu = 0.3$, we get

$$\sigma_t^{\max} = 1.03 (pr/\delta) \text{ when } \beta x = 1.85. \quad (6.88a)$$

An overall check on strength can be made using energy theory according to formula (6.68).

The stresses in spherical bases will be less than those found by formulas (6.87) and (6.88), therefore you can be limited in checking the strength of the cylindrical section of the housing, if the values are the same.

A vacuum can occur while the gas tank is in operation, therefore, the stability of the gas tank envelope must be checked under external pressure. The critical pressure can be found from the formula

$$[p] = 6.49 \cdot 10^{-6} E_t \frac{D}{l} \left[\frac{100 - (\delta - c)}{D} \right]^2 \sqrt{\frac{100(\delta - c)}{D}}.$$

where $\{p\}$ is the allowable external pressure $\{p\} < p_{cr}$; D is the envelope's internal diameter in cm; l is the distance between stiffening ribs in cm; δ is wall thickness in cm; c is the addition for off-gauge sheet metal ($c = 0.08$ cm); E_t is the modulus of elasticity for steel at a temperature of 50°C . For St.3 steel $E_t = 2.02 \cdot 10^6$ kg-f/cm² and for 09G2S steel $E_t = 1.93 \cdot 10^6$ kg-f/cm².

The last formula is used when the following envelope parameters are present and r_i is its radius:

$$\frac{\delta - c}{r_i} \leq \frac{1}{30};$$

$$1.5 \sqrt{\frac{\delta - c}{r_i}} \leq \frac{l}{2r} \leq \sqrt{\frac{r_i}{\delta - c}};$$

$$0.3 \frac{E_t}{\sigma_{co}} \sqrt{\left(\frac{\delta - c}{r_i}\right)^3} \leq \frac{l}{2r}.$$

§ 8. Spherical Gas Tank Design

Spherical (globe) gas tanks are intended to be used to store gases under pressure which either are in the gas state or liquefied. Therefore, they see excess and hydrostatic pressure loads. Basic, momentless theory is used to design the spherical envelope. Momentless theory breakdown occurs at the point in the construction where the envelope rests on supports.

The internal excess pressures in the envelope create meridional and circular forces

$$N_\varphi = N_\theta = N = \frac{pr}{2}, \quad (6.89)$$

whence we can find the envelope thickness

$$\delta = \frac{nr}{2m\sqrt{\varphi}} + c, \quad (6.90)$$

where n is the transfer factor ($n = 1.2$); p is the excess pressure; m is the working condition factor ($m = 0.65$); ϕ is the welded joint strength factor ($\phi = 0.95$); c is the addition to envelope thickness; for off-gauge metal $c_1 = 0.8$ mm; and $c_2 = 2.8$ mm for dished metal ($c = c_1 + c_2$); and R is the design load for steel.

The radial deflections for the envelope subjected to an internal pressure will be

$$\Delta = \frac{r}{E\delta} N (1-\mu) = \frac{pr^2}{E\delta} (1-\mu). \quad (6.91)$$

We shall use the same equations given in § 3 of this chapter to find the bending moment at the support, i.e., we shall find a moment for a strip one unit wide, and tangent to the envelope at the point of support. We can write the equation for the strip in the form

$$\frac{d^4 Q}{d\psi^4} + \lambda^4 Q = 0.$$

We shall set up the general solution for this equation in the form

$$Q = C e^{-\lambda\psi} \sin(\lambda\psi + \gamma), \quad \text{where } \psi = \alpha - \varphi.$$

Assuming that the envelope is rigidly reenforced at the support and remembering that there are no support displacements, we can set up the following boundary conditions when $\varphi = \alpha$:

rotation angle $V = 0$

deflection $\Delta = (pr^2/E\delta) (1-\mu)$

The equation for the radial deflection, as opposed to equation (6.15) § 3 takes the form

$$\Delta = -\frac{r}{E\delta} \lambda \sqrt{2} C e^{-\lambda \varphi} \sin\left(\lambda \varphi + \gamma - \frac{\pi}{2}\right). \quad (6.92)$$

Substituting our boundary conditions into this equation and into equation (6.13), we get

$$\left. \begin{aligned} \gamma &= \pi/2 \\ C &= (pr/2\lambda)(1-\mu) \end{aligned} \right\}. \quad (6.93)$$

Introducing values for the arbitrary constants into equation (6.14) § 3, we get an expression for the bending moment at the support

$$M_a = \frac{pr^2}{4\lambda^2} (1-\mu) = \frac{pr\delta}{4\sqrt{3}} \sqrt{\frac{1-\mu}{1+\mu}}. \quad (6.94)$$

The bending moment in the circular direction is

$$M_\theta = \mu M_a = \frac{pr\delta}{4\sqrt{3}} \mu \sqrt{\frac{1-\mu}{1+\mu}}. \quad (6.95)$$

In designing the envelope, the stresses due to bending at the support are added to the stresses due to the internal pressure and these are reckoned up using momentless theory.

The meridional stresses are

$$\sigma_\varphi = \frac{pr}{2\delta} + \frac{6M_a}{\delta^2}; \quad (6.96)$$

the circular stresses are

$$\sigma_{\phi} = \frac{nr}{2\delta} + \frac{6M_{\phi}}{\delta^2} \quad (6.97)$$

The overall check on strength according to the energy theory is

$$\sqrt{\sigma_{\phi}^2 - \sigma_{\phi}\sigma_{\theta} + \sigma_{\theta}^2 + 3\tau_{\phi\theta}^2} \leq nR.$$

It must be noted that we are not considering the stresses created by the envelope's weight since this complicates the design a great deal.

When testing the globular gas tank or when storing liquefied gases or products with a low boiling point, the envelope is subjected to a hydrostatic load in addition to the excess pressure. We shall examine the spherical envelope when filled with a fluid and supported along the parallel circle AA (Fig. 6.22). The hydrostatic pressure at a level corresponding to angle ϕ will be

$$p = \gamma r (1 - \cos \phi). \quad (6.98)$$

The equalized action of this pressure on the ring elements of the envelope corresponding to the angle $d\phi$ will be

$$dR = -2\pi r \gamma r (1 - \cos \phi) \sin \phi \cos \phi r d\phi.$$

Then the equalized action for the entire section of the envelope corresponding to angle ϕ is

$$\begin{aligned} R &= -2\pi r^3 \int_0^{\phi} \gamma (1 - \cos \phi) \sin \phi \cos \phi d\phi = \\ &= -2\pi r^3 \gamma \left[\frac{1}{6} - \frac{1}{2} \cos^2 \phi \left(1 - \frac{2}{3} \cos \phi \right) \right]. \end{aligned} \quad (6.99)$$

The equilibrium condition for the envelope section corresponding to angle ϕ can be expressed by

$$2r_0 N_\phi \sin \phi + R = 0, \quad (6.100)$$

where $r_0 = r \sin \phi$.

Substituting the value of R found in formula (6.99) into equation (6.100) we get

$$N_\phi = \frac{\gamma r^3}{6 \sin^2 \phi} [1 - \cos^2 \phi (3 - 2 \cos \phi)] = \frac{\gamma r^3}{6} \left(1 - \frac{2 \cos^2 \phi}{1 + \cos \phi} \right). \quad (6.101)$$

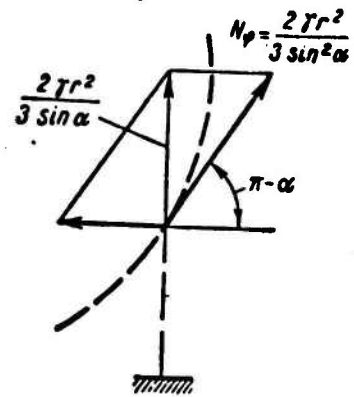
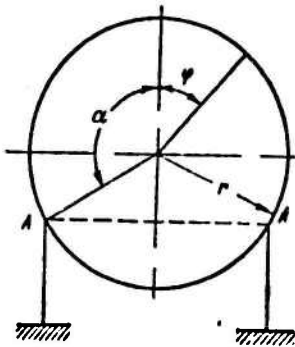

Fig. 6.22. To find conditions in a spherical envelope.

Fig. 6.23. To find reactions at a support in a spherical storage tank.

We shall take the following basic equation for the momentless condition of the envelope of rotation

$$\frac{N_\phi}{r_1} + \frac{N_\theta}{r_2} = -Z = p \quad (6.102)$$

and in it we shall set $r_1 = r_2 = r$, and the value of N_φ from (6.101) and the value for p from formula (6.98). We get

$$N_\theta = \frac{\gamma r^2}{6} \left(5 - 6 \cos \varphi + \frac{2 \cos^2 \varphi}{1 + \cos \varphi} \right). \quad (6.103)$$

Equations (6.101) and (6.103) are valid only for the case where $\phi < \alpha$. In that section of the envelope below the support cross section, the resultant R still includes the sum of the vertical reactions due to the weight of the fluid within the volume distributed around the ring AA. This sum equals $4/3 \gamma \pi r^3$. The resultant for the lower section is

$$R = -\frac{4}{3} \gamma \pi r^3 - 2 \gamma \pi r^3 \left[\frac{1}{6} - \frac{1}{2} \cos^2 \varphi \left(1 - \frac{2}{3} \cos \varphi \right) \right]. \quad (6.104)$$

Then we get the following for the meridional force

$$N_\varphi = \frac{\gamma r^2}{6} \left(5 + \frac{2 \cos^2 \varphi}{1 - \cos \varphi} \right); \quad (6.105)$$

and for the ring

$$N_\theta = \frac{\gamma r^2}{6} \left(1 - 6 \cos \varphi - \frac{2 \cos^2 \varphi}{1 - \cos \varphi} \right). \quad (6.106)$$

It is evident from equations (6.101) and (6.105) that the meridional forces N_φ at the ring experience a discontinuity and differ from one another by $2\gamma r^2/3 \sin^2 \alpha$. We can get this value if we lay out a vertical support reaction along a unit length of the sphere tangent to the meridian and in the horizontal direction. The component tangent to the meridian equals N_φ , the value

for the discontinuity at the support, while the horizontal component sees a reaction in the support ring which causes, in turn, an equal amount of compression (Fig. 6.23). In practice, to avoid creating horizontal component reactions, support struts are set at an angle so that they are tangent to the meridian at the support point.

The annular forces N_θ also undergo a step jump change at the support ring AA.

The step jump change in the forces N_ϕ and N_θ indicate that there is a localized deformation at the support, i.e., the moment-less condition of the envelope is violated.

At some point while the spherical envelope is working as a storage tank or a gas tank a vacuum can occur. The amount of vacuum that can be tolerated depends on the critical stress or the critical pressure for the particular envelope.

The critical stress is

$$\sigma_{cr} = k \frac{E\delta}{r}; \quad (6.107)$$

the critical pressure (external) is

$$p_{cr} = 2k \frac{E\delta^2}{r^2}, \quad (6.108)$$

where r is the spherical envelope radius, δ is its thickness and k is a factor derived experimentally ($k = 0.1$)

The amount of vacuum which can be allowed is found by the formula

$$P_{all} = \frac{2\sigma_{cr} k_2 m \delta}{n r}, \quad (6.109)$$

where k_2 is the material uniformity coefficient; m is the working condition factor ($m = 0.65$); and n is the transfer coefficient ($n = 1.2$).

The gas tank safety devices (values) must be designed for the P_{all} value.

Chapter Seven

MANUFACTURE AND ASSEMBLY OF STEEL STORAGE AND GAS TANKS

§ 1. Storage and Gas Tank Installation Methods

The Plate Method of Assembling Storage and Gas Tanks

The metal plates used to erect modern storage tanks are received from metal plants as flat pieces and usually do not require straightening. The vertical and horizontal edges of sheet metal plates up to 6 mm thick have the edges milled. Edges of plates from 7 to 34 mm thick run through automatic, multiheaded, flame cutting machines.

Sheets are rolled in three-roller rolling mills. Sometimes, edges are given a preliminary rolling treatment. In special cases, plates are painted or primed.

Special pile-drivers or self-propelled cranes are used to erect storage tanks and sometimes, derrick-cranes are used, when building a cluster of large storage tanks. Seams are welded by mechanized devices (fig. 7.1).

Storage tank floating roofs are assembled piece by piece in a temporary scaffolding; this calls for a considerable amount of work, including manually welding seams in various positions and at different lengths. Sometimes, the floating roofs, raised by the water flooded into the lower section, are used as a scaffolding for assembling the upper housing section. It takes five months or more to assemble a 50-100,000 m³ storage tank by the plate method.

The so-called "spiral" sheet metal plate method is being used in the Ch SSR and it consists of the following. The plate parts for the first belt layer are set up and welded at the base

using normal methods; the plates are cut so that their upper edges form a helix and have a pitch equal to the belt height. The roof cover and the upper belt plates which also form a helix meet at the base.

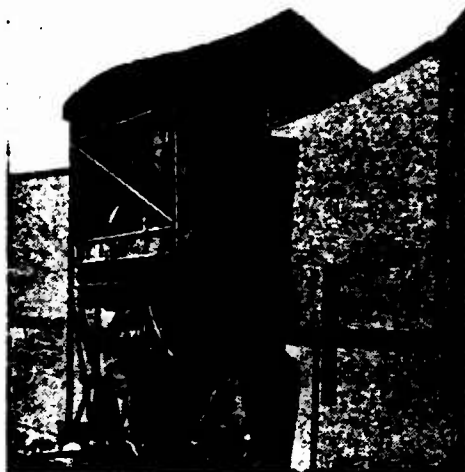

Fig. 7.1. Installation for mechanized welding of joints in a storage tank housing.

A cutaway section of the housing plates for the type of storage tank is shown in Fig. 7.2. Drive blades are set in the clearance spaces between belts; they force the upper part of the storage tank to rotate around the vertical axis and move relative to the lower section. The next, normal housing plate is attached at the opening made by the displacement of the upper section with respect to the face of last plate; then it is fastened down, etc. The assembly process is completed at one work site. The sheet previously installed is then welded at the next work station.

This method has the following advantages as compared to the usual sheet metal assembly method: roof and housing are assembled in the low position; these permanent working positions are

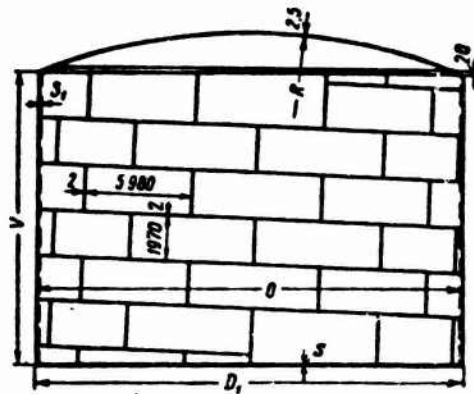

Fig. 7.2. Cutaway section of a storage tank housing assembled by the "spiral method".

more convenient and the equipment is relatively simple. The "spiral" method increases labor productivity over the usual plate method of assembly, but it is somewhat limited in the working frontage for assembling the housing.

A combination method is used at PNR to build the housings for water type storage tanks in large gas tanks. The thinner, upper housing section is made from rolled stock. Then it is lifted up entirely by a special jack and the one or two remaining lower layers are made from thicker metal which cannot be rolled using present day equipment.

The Domestic Industrial Method of Installing Storage Tanks Using Rolled Stock Construction

The domestic storage tank construction industry followed the industrial method of manufacturing all construction items as developed over the past two decades; this called for introducing mechanized welding methods and reducing all assembly and welding work to a minimum. The basis of all this industrial technology lay in the way sheet metal storage tank envelopes were rolled. A method suggested by The Paton Electrical Welding Institute

(the author is G. V. Raevskiy, a doctor of technical science). As the result of experiments in manufacturing storage tanks at factories, the manufacture of rolled and large envelope assemblies for wet type gas tanks and other requirements needing sheet metal construction was successfully mastered.

The welded panels are subjected to several types of deformations while being made in double tiered rolling machines. The stressed state of the panels in modern machines is found by measuring the deformation in the rollers while the panels are being rolled. The roller radius is the same for all machines, and for all practical purposes, can be taken as equal to the drum radius on which the panel is being rolled - $R_f = 1330$ mm.

The panel deformation driving rolling can, accurately enough, be considered like pure deformation in an ideally viscoelastic material which follows the law on plane sections subjected to a viscoelastic deformation.* As a rule, rolled steel has a sharply defined yield-point at elongation and satisfactorily fits the assumption of an ideal viscoelastic material. The relative deformation in the edges of the draw plates in this case will be fixed by the deformation radius according to the formula

$$\epsilon = \delta/2R. \quad (7.1)$$

If the plate thicknesses change, the deformation in the different panel belts will be different. The thinnest plates may be bent elastically but still not withstand the plastic deformations. The stresses created in the sheet's cross-section are described by the triangles (fig. 7.3a).

* This section has been prepared together with engineer G. A. Ritchik.

In thicker sheets the relative deformation at the draw plate edges exceeds the limit values for elastic deformations in a given type of steel: $\epsilon_e = \epsilon_r = \sigma_T/E$ (Fig. 7.3b).

Besides the elastic deformation, plastic (residual) deformations will occur and fibers will yield at the draw plate edges. As the sheet thickness increases, the zone for developing plastic deformations increases, provided the rolling radius and material yield point are as before; however, the height of the elastic zone remains constant. The latter indicates that any plate thickness will deform, under the given conditions of roller radius and material yield point, in the elastic stage, without undergoing plastic deformations. The height of the elastic zone can be found by the formula

$$a = \frac{2R_r \sigma_T}{k} \quad (7.2)$$

If the relation between σ_T and a is known, and the rolling radius is constant for each yield point limit, it is easy to find the elastic and plastic deformation limits and, consequently, the curve for the panel stress condition during rolling.

After the panel is released from the roller, thin plates, which were put into an elastic state by the rolling, are straightened out. Thick plates whose edges were plastically deformed by the rolling process do not straighten out to a significant degree and will maintain a residual radius of curvature which is a function of roller radius and can be found by the formula

$$R_{res} = \frac{2R_r}{k^2 - 3k + 2} \quad (7.3)$$

where $k = a/\delta = \epsilon_T/\epsilon$ is the fraction of the elastic core running throughout the plate's thickness.

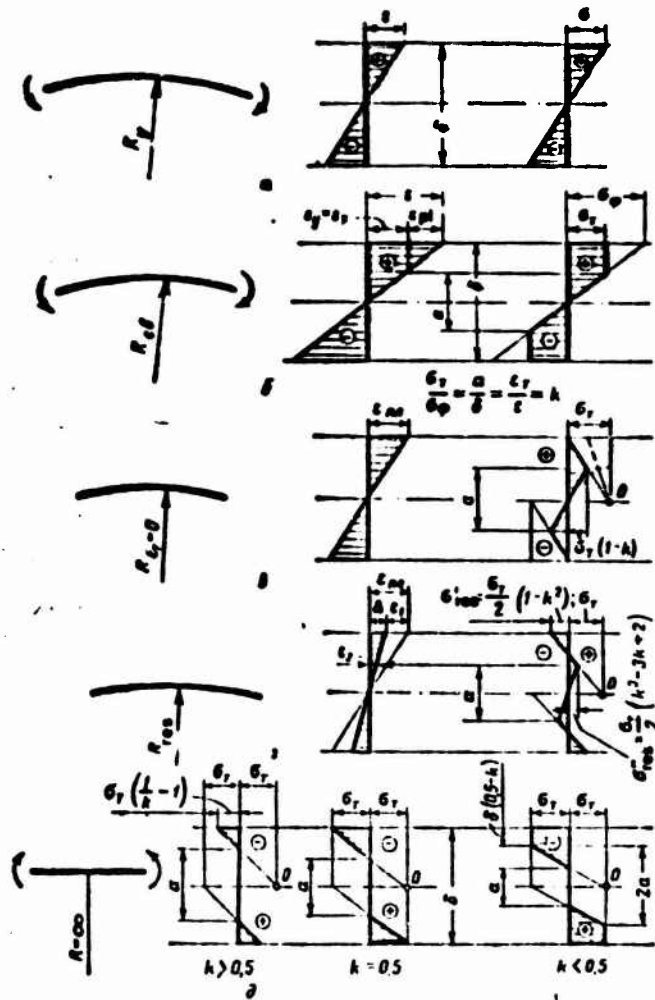

Fig. 7.3. Deformations and stresses in a viscoelastic deformed strip

In being relieved from R_r to R_{res} , the plates will pass through an interim condition where the elastic deformations in the draw plate edges will disappear ($\epsilon_e = \epsilon_T = 0$) and only the plastic (residual) deformation ϵ_{pl} will remain. In this case, the stress at the draw plate edges equals zero (Fig. 7.3c). However, the sheets will continue to relieve itself, thanks to the elastic stress forces within the core. When this happens,

the outside edge fibers will compress themselves (and correspondingly the internal fibers will stretch out); this creates the appearance of compressive stresses (stretching out) σ_{res} . When the areas under the compression and extension curves are equal with respect to the neutral axis, strip straightening will stop. Then the external edge fibers will compress to ϵ_1 and the internal fibers will expand the same amount. The sheets will have a residual radius of curvature R_{res} , a true, relative deformation in the edge fibers of $\Delta = \epsilon_{pl} - \epsilon_1$, the residual stresses will be $\sigma'_{res} = \epsilon_1 E$ and the residual stresses at the edge of the elastic and plastic zones will be $\sigma''_{res} = \epsilon_2 E$ (Fig. 7.3d).

If further straightening is required, for example, to meet the tank's design radius, the residual stresses in the fiber extremities will increase but will decrease at the edges of the elastic and plastic zones. The stresses in the elastic core of fully straightened plates is zero, but they reach the yield point at the edge fibers, if the fraction of the elastic core throughout the entire cross-section, $k = a/\delta$, is equal to or less than 0.5 during the rolling process.

If this relation exceeds 0.5 for a given roller radius, the stresses in the fiber edges will be less than the yield point (Fig. 7.3e).

The stresses in fiber edges for all curvature conditions in plates due to rolling up to the flat plate condition are expressed by the formula

$$\sigma' = \frac{\sigma_y}{k} \left(1 - k - \frac{R_r}{R} \right), \quad (7.4)$$

where R is the radius of curvature for plates in a specified condition. When $R = R_{res} = 2R_r/k^3 - 3k+2$ and $R = \infty$ (i.e., when the sheet has been straightened out completely), the formula will

have the following partial expressions:

$$\sigma'_{res} = \frac{\sigma_r}{2} (1 - k^2), \quad (7.5)$$

$$\sigma'_{st} = \sigma_r \left(\frac{1}{k} - 1 \right).$$

When $R = R_{dr}$ (R_{dr} is the design radius of the storage tank) we get a value for the residual stresses in the fiber edges in the housing of the assembled storage tank

$$\sigma'_{res, dr} = \frac{\sigma_r}{k} \left(1 - k - \frac{R_r}{R_{dr}} \right). \quad (7.6)$$

From Formula 7.6, it is evident that the term R_r/R_{dr} can be neglected in large storage tanks where R_{dr} is appreciably larger than R_r , and then σ'_{st} , i.e., the large storage tanks will have residual stresses in the housing which practically correspond to straightened plates (Fig. 7.3e). The stress curve in this case is, as in the stress curves during rolling, are found by using the height of the elastic core, a .

The stress at the boundary of the elastic and plastic zones while the strip is being straightened can be found by the formula

$$\sigma^e = \sigma_r (R_r / R). \quad (7.7)$$

For the particular cases where $R = R_{res}$, $R = R_{dr}$ and $R = \infty$, the expression takes the form

$$\sigma'_{res} = \frac{\sigma_r}{2} (k^2 - 3k + 2); \quad (7.8)$$

$$\sigma'_{res, dr} = \sigma_r (R_r / R_{dr});$$

$$\sigma'_{st} = 0.$$

Thus, it is evident that typical storage tank housings with capacities 10-20,000 m³ before being filled up still have residual stresses which approach the yield point. Experience over

many years in operating these types of storage tanks makes it possible to draw a conclusion about their overall reliability.

The storage tank housing can be regarded as a flat strip whose length to thickness ratio is in the order of 10,000 - 12,000. Loaded with moments on both ends, the strip is deflected into a full circle. The stress condition in the housing is different for the upper and lower belts because of the different thicknesses of steel.

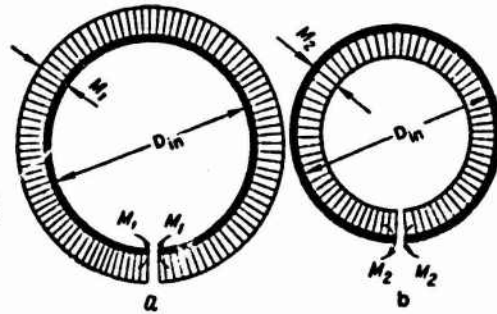

Fig. 7.4. Residual bending moments, introduced into the construction of a reservoir housing.
a- in the upper belts; b- in the lower belts.

A bending moment must be applied to the thin, upper walls which are trying to revert back to flat planes due to their elasticity after release from the rollers, and during this phase the outer fibers (Fig. 7.4a) move out.

A moment in the opposite direction (fig. 7.4b) is applied to the thick, lower belts which have been subjected to deformation in the viscoelastic stage and which still have a curvature larger than the design value, and during this phase the internal fibers move out.

The process of rolling high or increased strength steel sheet stock with yield points between 34-35 kg-f/mm² and higher is

marked by several characteristic features - the zone of plastic deformation is reduced, panel elasticity is increased, etc. This improves the chances for using the rolling method and widening its sphere of application and allows using thinner stocks of high strength steel in place of thicker, low alloy steels.

§ 2. Installations for Manufacturing Rolled Stock

Installation Construction

The construction features of a two-stage stand is shown in Fig. 7.5.

The stand is made of metal and has two operating areas. A panel is assembled and welded on one side in the first stage. The sheets are collected by an electromagnet. A free turning, grated drum, 3,300 mm in diameter, is set up in the rear section of the stand and the first section has a rotating device with a stiff mechanical drive (Fig. 7.6).

The plate stock to be processed is delivered by crane to the assembly position in the first tier. Then, one by one, they are transferred by electric telfers fitted with electromagnets to a collection area. The edges, collected into a section of plates, are gathered up by their butt ends by an electromagnet and taken to a flat, copper slab and after first being reenforced with tack welds are then welded by a TC-17M automatic welding head.

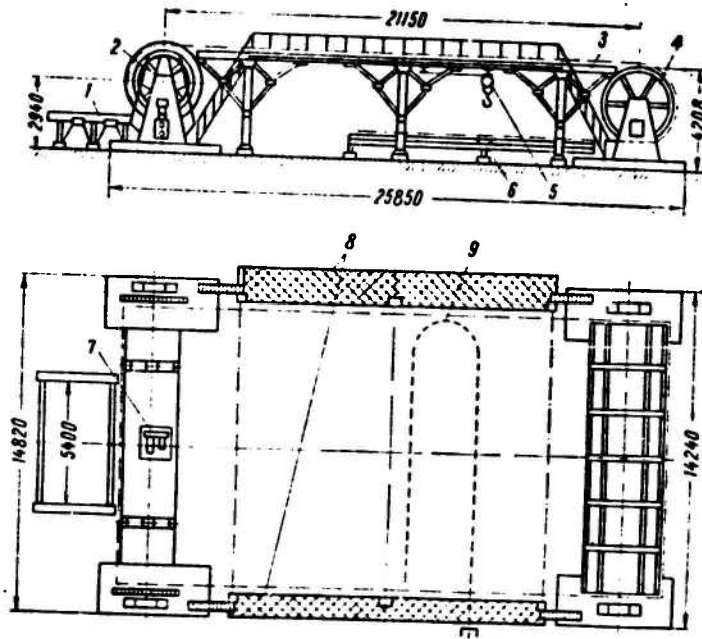

Fig. 7.5. Two-stage stand for manufacturing rolled structural members.

1- cradle for the finished roll; 2- rolling device; 3- cradle for the second tier; 4- guide drum; 5- telpher; 6- first tier cradle with electromagnets; 7- rolling device drive; 8- areas; 9- telpher monorail.

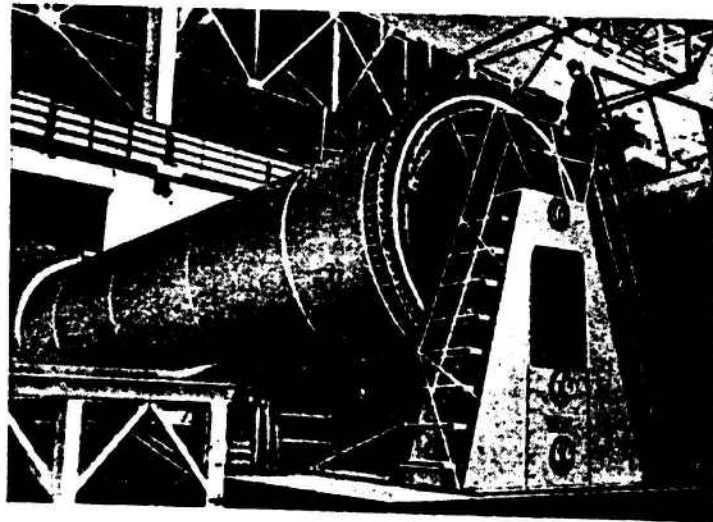

Fig. 7.6. Rolling stand

Depending on how far along they are in manufacture, the welded sections are moved along the upper tier in the stand and then are turned around by the drive drum at the rear of the stand. Welds are made automatically on the other side in the upper tier then tested. At this point, all welds are inspected for defects. Then the plate is rolled by a special stand device consisting of two housings set up on a foundation. The housing axes are reinforced with 3.3 mm diameter faceplates. A gear ring is set up around the faceplate perimeter; this meshes with a spur gear drive. The drive has a 7 KW electric motor connected to the housings by a reduction gear and several additional sets of gears. Faceplate rotational speed is set so that the plates move at a 2 m/min velocity during the rolling operation. The plate is then picked up on a grid framework made of from ladder type structures and central struts fitted with channel bar rings 2660 mm in diameter which is equal to the internal rolling diameter. Framework face areas are connected to the face plates by four pintles which pull out on each side. Beams pick up the rolled pieces after the rolling

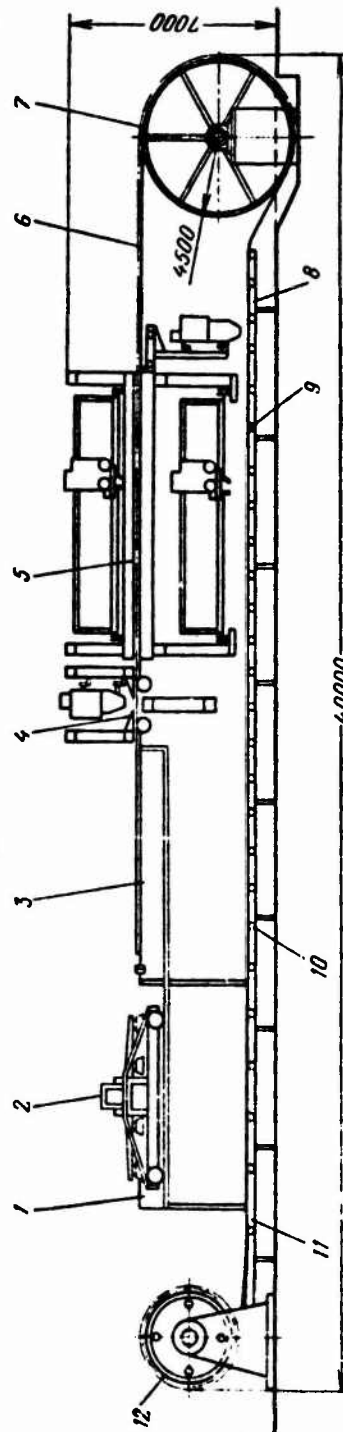

Fig. 7.7. A mechanized mill for manufacturing rolled construction items
 1- storage area for sheet metal items; 2- self propelled carriage with pneumatic clamps;
 3- section assembly area; 4- transverse seam welding; 5- longitudinal seam welding; 6- the
 area for external inspection of welds; 7- rear drum; 8- rewelding of transverse welds;
 9- rewelding of longitudinal welds; 10- weld control and correction area; 11- area for
 primary the plate; 12- rolling installation.

operation and after the edges have been reenforced. Then the unloaded pintles move away from the framework and the rolled article is moved into a bin.

A mechanized rolling mill capable of rolling plates up to 18 m wide can provide the following:

- 1) the maximum amount of mechanization and automation of all the processes in the manufacture of rolled building products;
- 2) a high production capacity because plates can be collected and welded with ideal devices which use effective techniques to control welded joints;
- 3) high productivity, including labor productivity
- 4) maximum improvements in workers' conditions.

A new mill can fabricate plates up to 16 mm thick. Plate dimensions are 150 x 6000 mm. The mill has been mechanized to handle the delivery of plates to the assembly area, the way they are enclosed and how the edges are clamped before being welded to the copper jointing rings. The high capacity welding devices make it possible to weld with two areas at accelerated speeds (up to 60-70 m/h); they have flux and gas exhausts systems as well as devices for controlling electrodes at the weld and other equipment which facilitates process control and welder working conditions.

As the plates are being rolled, the starting and trailing plate edges are reenforced so as to reduce significantly the time required for these operations. The rolled article is separated from the roller faceplate semi-automatically. After being released from the support, the rolled plate is moved along the beams to the platform and is delivered to a temporary storage bin.

The output of building products on the mechanized mill is significantly higher than other double tiered installations and labor productivity is 2.5 times higher.

Technological Aspects of Manufacturing Rolled Building Products

Both storage and gas tank housings and bases are made out of steel plates 4-16 mm thick or thicker. The normal plate dimension is 1500 x 6000 mm. Metallurgical plants supply sheet stock with roughly formed edges to a 10 mm tolerance for the short dimension and 15 mm for the long dimension. Before plate stock material is sent out the manufacturing plant issues a certificate stating the steel's mark designation, chemical composition, and mechanical properties. Plate stock to be used in manufacturing construction items for storage tanks must not have any spalling, coatings, cracks or cavities.

When necessary, plates are straightened on seven or nine roller rolling mills. Plate edges are trimmed on guillotine shears on edges. As a rule, plates are not laid out but the edges are trimmed using stops. In some cases plate cutouts are outlined and center-punched (particularly curved plates used on the base edges).

The guillotine shears are used to trim the long edges of plates 4-5 mm thick, when they are to be subsequently lapped, as well as for all transverse edges. The longitudinal edges which will be butted together need special handling. These edges are milled on edgers at right angles to the plane of the sheet and without any kind of dressing. Ordinarily the plates are edged in batches of four plates; this increases process productivity. The edges of plates which are to be used for base bottoms are also cut on guillotine shears by making a series of cuts tangent to the outlined circle.

The processed plates are marked for thickness, order and part number, and are then put up as sets in special containers.

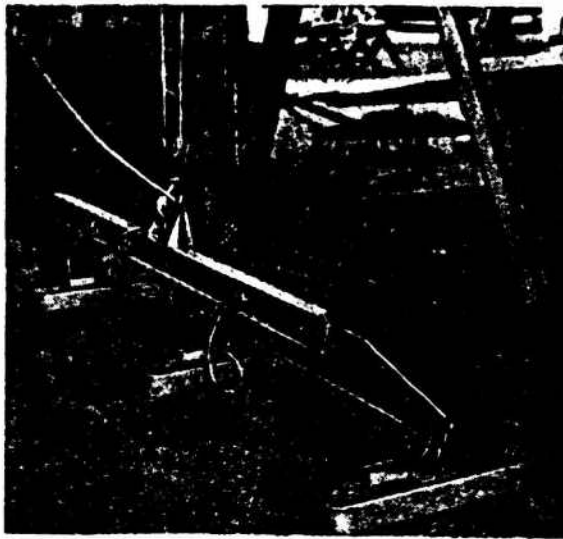

Fig. 7.9. Electromagnetic clamps for delivering plates for assembly.

Each container is packed with those plates with the right thicknesses to assemble one or two sections of the panel.

Electromagnetic or pneumatic clamps are used to move plates during operations because this eliminates edge deformation.

When a section of the panel is erected and overlapping joints are needed, those plates which must face down are first put in at the required spacing. The short edges of plates bear against the plate edges of the preceding section. Plates which make butt joints are put in a row, flush against the preceding section to form the smallest gaps, a welding requirement. Special attention is given in making the panel's lower edge straight; this is checked by chocks or graduations on the machine either visually or by stretching twine. The panel width is controlled by measurement surveys. The straightness of the rear edge section is also checked and this may not have an offset greater than 2-3 mm. Small displacements in the plates are possible because of the variation in allowable clearance limits between edges or overlap dimensions. Plates which have been assembled into a section are clamped. If assembled on a magnetic stands, plate position is

first determined by the magnet connections, then by the electric clamps. The overlapped joints in the first layer are welded intermittently. Subsequently, they wind up inside the assembled reservoir.

Depending on the amount of assembly and welding, the panel moves along the machine like a wide steel belt. When the machines are operating on a regular basis, one panel follows behind the other. The beginning of each new panel is secured by six to eight steel belts each with a 100 x 4 mm or 5 mm cross-section and about one meter long.

As the sections move along and turn, these strips are also put along the bottom but differ in length so as to compensate for the curved contours in these panels.

After the machine stops operating, a new panel is moved in either using two cables or long steel strips attached at one end of the panel while the other is affixed to the installation's rotating drum.

Frequently, several housing and base panels for small capacity storage tanks are rolled in one pass.

The panel's leading edge is reenforced with steel strips which have been welded to the framework rings (the ladder or the central strut). The first edge is put into a one meter long pocket sections in the ladder (or framework) ring elements so that the initial edge does not move away from the ladder rings and the other framework because of its elasticity, and is not deformed during subsequent turns of the framework. As the turning action starts, the leading edge does not project out beyond the plane of the rings and the panel rotates without harming its curvature.

A spring loaded roller is used to regulate and improve winding tightness of the roll.

The trailing edge of the rolled panel is reinforced by welding strips connecting the two panels to the last wound section of the roll. It is in intimate contact with the roller when the rolling is done. The finished roll with its reinforced rear edges is released from the faceplate of the rolling installation and is rolled out to a bin.

The plate elements used in wet type gas tanks are similar to the rolled panels used in storage tanks. They are made on the same types of machines and under the same technical process as ordinary storage tank construction products.

Production Technology in Manufacturing Roofs, pontoons, Ladders and Other Construction Items.

Serial production of roof panels which, for the most part, are of one type for storage tanks of a given capacity, makes it possible to organize the manufacture of parts, and the assembly and welding of these panels on an assembly line basis.

Sheet metal parts with structural members are made in the workshop with ordinary equipment and are put on chocks or templates. Angles and channels are cut on power driven shears, while heavy I beams are cut by oxyacetylene torches. Sheet metal items which will cover the roof are cut on guillotine shears. Straightening or bending pieces is done either on cam operated presses or on bending rolls. Finished parts are collected by types and sent in containers to the place of assembly.

Panels are collected at special jigs (Fig. 7.9) which are mirror image frameworks, duplicating the panel shape. Jigs are set on saw horses to facilitate work.

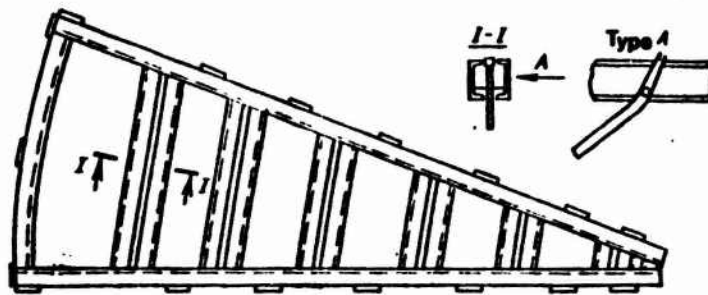

Fig. 7.9. A jig for assembling roof panels for 1,000 - 3,000 m³ storage tanks.

All parts of the framework are clamped. The roof covering is intermittently welded to the framework while still under compression by lever type clamps. Plate edges are pressed against the stiffening ribs by special clamps which are placed between jig channel pairs.

The assembled panel is removed from the jig by the lifting angles welded to the longitudinal parts of the frame and is then transferred to the welding site. The panels are turned over and set up on saw horses to weld the cover seams. Roof cover seams are welded automatically by a TS-17M automatic welding head under a layer of flux.

Since all butt joints in the sheet metal covering are supposed to fall over the transverse ribs, the sheets are not clamped down.

The spherical roof panels for 10,000 and 20,000 m³ storage tanks are also assembled and welded on jigs but the operations carried out here are more complicated. Each spherical panel is divided into two parts for handling purposes. A special jig is used for each of the parts. The assembled sections usually receive an assembly check at the factory.

Storage tank pontoon ducts or floating roofs as well as members of the stiffening ring which is so necessary in constructing the spherical covering are assembled and welded in separate jig-positioners.

The stair flight and circular areas for the ladders are assembled in the jig separately. Then these parts are assembled to the longitudinal angles and ties. Assembled ladders are welded on a roller stand against which their rings rest or else it is turned around at that spot by a positioner which has two power driven end faceplates. The roof's central struts are usually made from tube stock and a circular piece is welded at each end which become the upper and lower support bases.

Construction of the inspection areas, the catwalk and guard rails are carried out in jigs and then are set up as a unit at the storage tank. Each item constructed is painted with the order number and mark designation.

Roofs, internal and external tracks and other parts for wet type gas tanks are manufactured at factories.

As a result of industrializing assembly work, the factories now manufacture larger metallic, hydraulic seal sections which formerly were installed piecemeal. These are assembled in fixtures and welded; frequently, the welding is semiautomatic. The length of hydraulic seal sections now installed runs around 4.5-5 m.

The construction features of gas tank roofs does not allow them to be manufactured as panels with a welded, sheet metal cover as is done for storage tanks. The roof rafters which are made depend on the construction volume. Fabricated rafters are checked against a template or a carefully disassembled rafter leg.

The roof edges come from the factory as separate segments which are then formed into larger units at the assembly site.

The thin sheet metal float covering usually comes in individual plates. Experience in assembling sheet metal roofing for gas tanks previously welded into panels proves that these can be made as rolled items.

The circular inspection areas for gas tanks are made at the same time the storage tank crozing angles are welded. This reduces the assembly time for the areas by the same amount it takes to unwrap the storage tank envelope.

When the internal and external tracks are being manufactured, special attention must be paid to their straightness and therefore, it is recommended that an assembly check be made throughout the entire length. The external tracks will not interfere with the usual railroad type platform. These are set up in two sections and cover-plates are expected to be put over the butt joints.

Forming the correct geometrical shapes in the panels during manufacture plays an important part in its subsequent assembly. Therefore, width, straightness of the longitudinal and transverse section edges, the perpendicularity of the transverse edges to the vertical, edge offsets and the proper spherical shape (or multi-angles) on the base panels is controlled during manufacture.

§ 3. Welding and Inspection of Factory Made Construction Parts

Welding storage and gas tank construction parts is done by generally accepted methods and with familiar equipment. However, in a number of cases, particularly when making rolled items, there are several peculiar things to watch in managing this work.

In accordance with the technical requirements (SNiP-B, 5-62* chapter 1) electrode wire, mark numbers SV-08, SV-08A, SV-08C, SV-08CA (GOST 2246-54), and 4-5 mm in diameter is used to weld panels along with flux, marks AN-348A, OST_s-45, etc.

When the base panels for the lower layer are being put together at the assembly area, the plates which form the initial sections of the base are laid out, thereby keeping control over the true curvature. Then the plates for the intermediate section of the base are put down, and these are usually lapped to the edge plates. The plates are clamped and welded. The remaining sections of the base are then assembled, watching to keep the correct circularity in the base.

The housing and base panels are welded on both sides.

The butt joints, welded in the first layer, must cover 70-80% of the butt joint section. It is especially important to observe this requirement in making the transverse seams (along the short edges) since they are subjected to bending at the root of the joint above, when the panel is turned over to the second layer.

§ 4. Shipping Storage and Gas Tank Construction Products

Storage tank and gas tank construction products are shipped from the manufacturing plant to the assembly area normally in two stages: the first goes from the factory to an intermediate warehouse via railroad flat cars or by water transport; the second goes from the intermediate warehouse to the assembly site via trailers, sleds or motor vehicles.

The housing and base rolled sections are the largest types of pieces. When manufactured on most existing types of stands, rolled lengths reach 12 m and the diameter is 3 m. According

to railroad rules, such rolled items are considered as clearance type cargoes. Each such sized roll is shipped on a four axle or on a pair of two axle flat cars. Loading the rolled construction products onto railroad flat cars is not difficult. The rolled items are simply rolled out from the bins at the rolling installations (or else from intermediate bins) onto flat cars located along side. Specially installed hoists on overhead travelling cranes are used to do this.

Before the roll is moved, special beams are set up between the bins and the flat car, the flat car wheels are braked with "braking chocks" and the flat car chassis on the side facing the bins is braced with struts or jacks so it doesn't topple. The roll is either placed directly on the flat car floor or on sole plates which have slight displacements (no more than 50 mm) on the sides. Wooden wedges reinforced with U shaped metal sections are nailed underneath and along the sides. The roll is secured to the flat car with special yokes which look like steel strips with a threaded tightening device or twisted wire rod. The yokes and twisted pieces are set up after the sides are raised and they are secured against the strut sockets. Support bars are set between the roll and the flat car side end faces; short struts are set up at the sockets; and additional twist-ties are also set up to prevent shifting.

Other storage tank construction products are shipped from the factory via railroad flat cars and are delivered to the assembly site, complying with the usual recommendations on shipping steel construction products and taking all precautions to prevent general or local deformations in the construction items. Special attention is given to such large sized curved shaped parts such as roof panels, particularly roof panels for 10,000 and 20,000 m³ storage tanks. Steps also are taken to avoid distorting principal elements when setting them onto flat cars, during intermediate storage or storage at the assembly site. These pieces are lifted by special

slings shackles which have been welded on at the factory. The panels are set with ribs bearing against wooden sole plates in such a manner that the all panel faces which have projecting edge face upward.

Rolls weighing up to 50 tons are moved to the pier or trailer by two tractors, one of which does the pulling while the other acts as a brake. Sometimes, when the number of rolled pieces is large, electric winches rated at 5 T-f capacity are used instead of the tractors, (fig. 7.10a). A cable 20-22 mm in diameter is used to move the roll down; several turns are made around the piece and then is secured with clamps. A similar cable to be used for braking purposes, is attached at the center of gravity of the rolled article. The flat car edge is supported with struts or screw jacks to prevent overturning. Wheels are braked or wedges are set against them.

The following measures are taken to insure safe working conditions:

a) a braking winch (or tractor) is set up opposite the rolled piece's center of gravity about 25 m away from the flat car's centerline;

b) the towing winch (or tractor) is set up 25-30 m from the railroad's centerline and about 4-5 m laterally from the rolled piece's end face;

c) the rolled items are unloaded under the direction of the person responsible for this operation and upon his signal which is visible both at the towing and braking positions;

d) initially, the towing cable should have a slight amount of tension so that it does not rupture when the rolled article moves from the horizontal onto the inclined plane;

e) there must be no people or equipment in the path of the piece to be rolled.

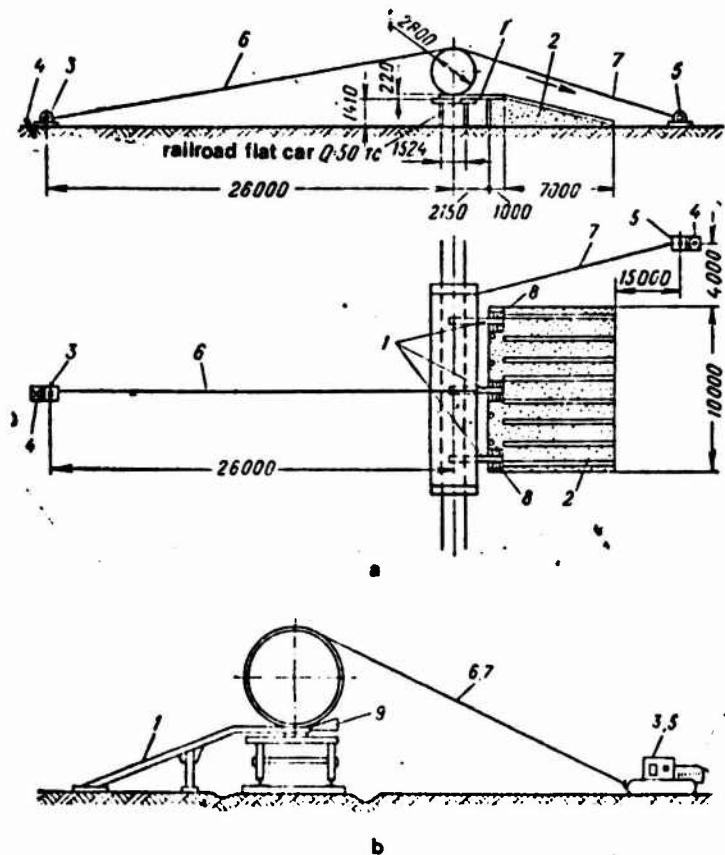

Fig. 7.10. Diagram for unloading rolled pieces.
a -- by winches; b- by tractor

1- unloading beams; 2- pier; 3- braking winch or tractor; 4- anchor;
5- towing winch or tractor; 6 and 7- braking and towing cables;
8- tie down area; 9- stock wedge.

Unloading a rolled piece using only one tractor is done in the following manner (see Fig. 7.10b). At one end the steel unloading beams rest against the flat car and on the other against

the ground via sole plates. Several turns of the cable are made around the roll; one end is then clamped to the roll while the other runs to the tractor hook. Long wedges are put under the roll on the tractor's side onto which the tractor will move the roll. While this is happening, the sole plates put on at the factory are removed from under the roll. Upon being moved by the tractor on its side, the roll, restrained by the cable, rolls over the wedges and then over the beams to the ground.

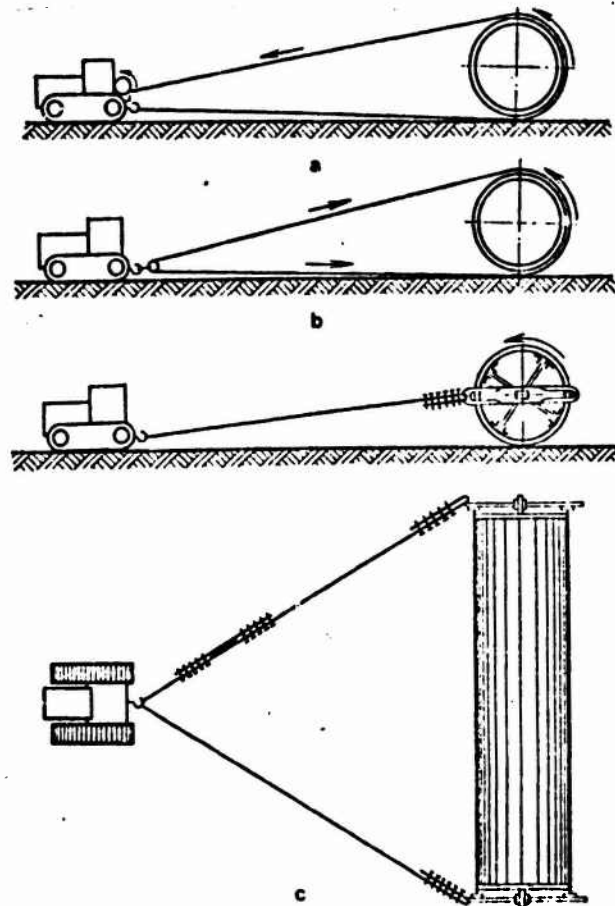

Fig. 7.11. Diagrams on moving a rolled piece by tractor.

Rolled items to be used in storage and gas tanks usually are transported to the assembly site on one or a coupled pair of trailers, depending on their load carrying capacity. If the

roads are good, one tractor with 80-100 HP or a heavy drawing capability is enough to move trailers with rolled pieces. Two or three ganged tractors are used when hauling over unpaved roads.

If the distance is short, items may be rolled along the ground or dragged on runners. Diagrams on moving rolled articles are shown in Fig. 7.11, where a is a rolling procedure using a tractor's winch; b used an "endless" cable; c uses two stock item crank arms, temporarily attached to each end of the roller. To turn the rolled item, its center section must be on a high spot in the ground or on beams, and the cable going to the appropriate end of the roll must be pulled.

§ 5. Erection of Vertical, Cylindrical Storage Tanks

Erection of Storage Tanks with Stationary Roofs

The main stages in erecting vertical, cylindrical storage tanks are:

- acceptance and laying out the foundation;
- erection, welding and laying out the base;
- setting up the vertical, rolled housing sections and the central support (either for erection or permanently);
- unfolding the housing while assembling cover panels (and stiffening rings in 10,000-20,000 m³ storage tanks).
- welding assembly joints
- testing the storage tanks

Erection methods are regulated by construction quotas, technical directives and plans for doing the work. The latter includes a listing of the required machinery, equipment, devices and materials.

Vertical, cylindrical storage tanks with capacities up to 5,000 m³ are set on sandy foundations.

The erection foundation is accepted in accordance to directives. These define the geometric dimensions of the foundation and its layout is verified at the center and along the edges (at no less than eight points and at a minimum of 6 m). The following deviations are allowed: layout of the foundation center - 150 mm; layout of points on the periphery - from $\pm 15 - 30$ mm between adjoining points; however, the difference between points laid out on a diameter shall not exceed 40-50 mm (depending on storage tank capacity).

Then two mutually perpendicular axes are laid out on the foundation base and the layout and location of the center is marked by pegs.

The rolled bottom is placed on the foundation either via an earthen panduce or directly from a trailer. Depending on reservoir capacity, the base may be laid as one piece (for capacities up to 1,000 m³) or in two to four sections, depending on conditions. When the base is put in as a single piece, provision is made to make it possible to locate it accurately after it is unrolled at its designed position. When bases are made from several strips, they are unrolled one by one and then moved into position or else each piece is unrolled at its designed position after the rolls have been placed in their proper positions around the foundation.

Before cutting the strips, cable nooses are placed around the roll to keep it from unrolling suddenly. One end of the cable is attached to the anchor and the other to the tractor (or to the hook or to the tractor winch drum). The strips are cut while the lower edge is clamped and since the nooses also stretch cut, it is possible to do this work safely.

Unrolling of a rolled base is shown in Fig. 7.12. Sometimes, an additional tractor is used to move the roll at the start of unrolling.



Fig. 7.12. Unrolling the rolled base of a 5,000 m³ storage tank

After all parts of the bottom have been unrolled, they are set up in the designed position, moving them around with a tractor or a winch with a cable and screw clamp.

In storage tanks which have a capacity of 10,000 to 20,000 m³ the base is made from a central section and sectioned ring parts. The central section is delivered to the area as 4, 5 or 6 mm panels made up as one roll for 10,000 m³ storage tanks or two rolls for 20,000 m³ storage tanks. Then either 18 or 24 base edge sections are delivered and these are made from steel 6-10 mm thick. The rolls of the central section are unrolled on the reservoir foundation by a tractor. All panels are set up in the designed locations and are tack welded electrically. Then the edge pieces are laid out around the perimeter and are butted together, while they are lapped at the center. A pipe laying crane is used to collect and distribute edge pieces around the foundation. A triangular sling is used to lift the edge pieces to which shackles or angles have been temporarily attached.

Assembled base seams are welded by electric arc automatically, semi automatically or manually; their soundness is tested under vacuum. The edges are welded to the remaining liners by seams about 300 mm long. The joint reinforcement is removed at that part of the seam where the edges meet the housing.

To reduce base deformation because of compression around its perimeter, the edges are welded to the central base section after the housing has been erected and the lower crozing seam has been completely welded.

The center and lines for erecting the housing and covering are laid out around the assembled and welded base; edges are welded to the central zone of the base only after the housing has been assembled and the lower crozing seam has been completely welded. Lines defining the outside diameter of the lower housing belt are laid out at the base's edge. Several different types of lines are laid out for 10,000 - 20,000 m³ storage tanks: they are to be used to erect the housing, to check the vertical condition when plumb lines dropped from parts of the stiffening ring, and to set up the central support column. A line is drawn (with a 1500 mm radius) to check the location of the central roof cover by plumb lines. The lines are drawn on the base with center punches or oil-based paint.

The housing for any storage tanks up to 5,000 m³ capacity inclusive comes as a rolled panel. At present, erection type self-propelled cranes with the proper hoisting capability are used more frequently to set the rolls into the vertical position.

The weight of rolls used in 100-700 m³ storage tanks never exceeds IOT, therefore this type of installation poses no problem.

Sometimes, the housings for several small capacity storage tanks are rolled into one roll.

Housing rolls for 2,000; 3,000 and 5,000 m³ storage tanks weigh 25, 34 or 45 tons, respectively. The housings for 10,000 m³ storage tanks come in two rolls while for 20,000 m³ storage tanks they come in three rolls, each weighing about 50T each. Rolls of this weight are lifted by one powerful crane or by two with less power. It is relatively easy to put the rolls into the vertical position using an A frame boom, block and tackle, and tractors or tractor winches. When using this method the roll may be rolled out on the bottom by one end or entirely and then have it set up on the grids (Fig. 7.13). An articulated device is placed under the lower end of the roll (Fig. 7.14); the center section of this device is welded or reinforced with tie pieces screwed to the roll. The tube ends of the articulated device which cross along the center section are reinforced by parts which are temporarily welded to the base. The legs of the A frame are connected to the pipe at this point. The rigging boom is in front of the roll. The upper portion of the block and tackle, the cables for slinging the top part of the roll, and the cable lines are attached to the upper section; these raise the rig into the vertical position. The sling cable is attached to the upper portion of the roll by a readily detachable timber hitch loop. A steel disc pallet made of 8 mm thick plate, with a 600-800 mm major diameter, is set in front of the roll.

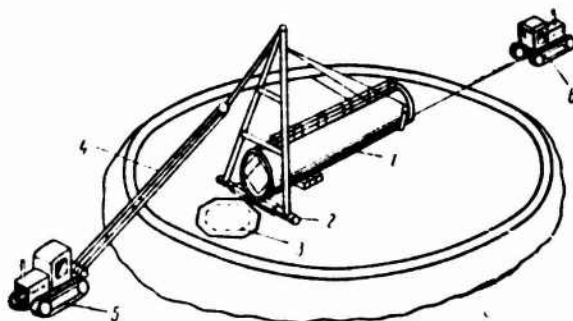

Fig. 7.13. A diagram showing how to get a roll ready for being hoisted into position with a drop type boom.

1- roll; 2- struts and articulated device; 3- pallet; 4- block and tackle,; 5- tractor winch; 6- braking tractor.

After this the roll is set up by its base on the pallet. The lower purchase block is fastened to the anchor on the tractor's winch hook while the cable is attached to the winch drum on the tractor (or to the tractor which, if it moves, can rupture it).

The roll is first fitted out with assembly ladders and vertical stiffening elements which are used later to support the panel's front edges. A braking cable runs from the top of the roll to the second tractor or winch. Before the roll is raised, a check is made to see that the roll's vertical axis, the hoisting mechanism, the upper part of the shever and the braking tractor all fall within one plane. This plane must be perpendicular to the hinge axis.

Hoisting is accomplished by winding the purchase cables around the tractor's winch drum or by the hauling tractor pulling the cable. The braking tractor slowly eases out the braking cable (Fig. 7.15). When the roll reaches a position where its center of gravity is over the hinge, the braking tractor goes to work. It supports the roll and makes it possible to lower it smoothly onto the pallet. The rig is taken down after the roll has been hoisted.

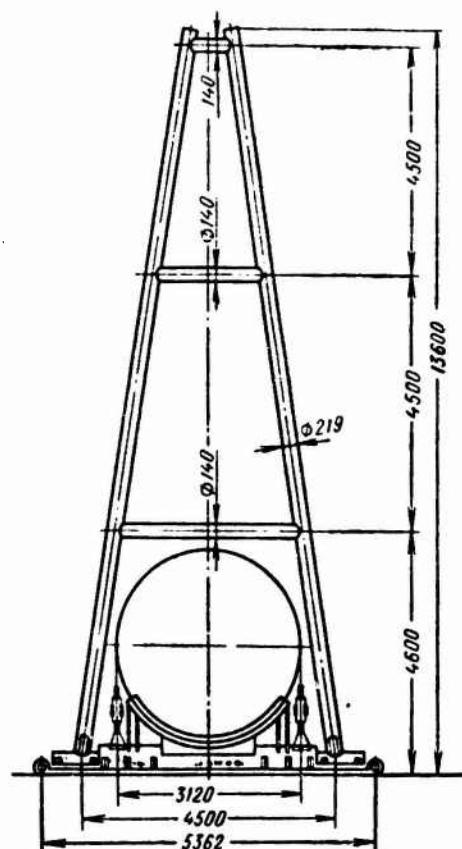

Fig. 7.14. The articulated gear and A frame for hoisting rolls.

Hoisting a roll up is a responsible operation and only experienced assembly men, assembly leaders or machine operators are allowed to participate.

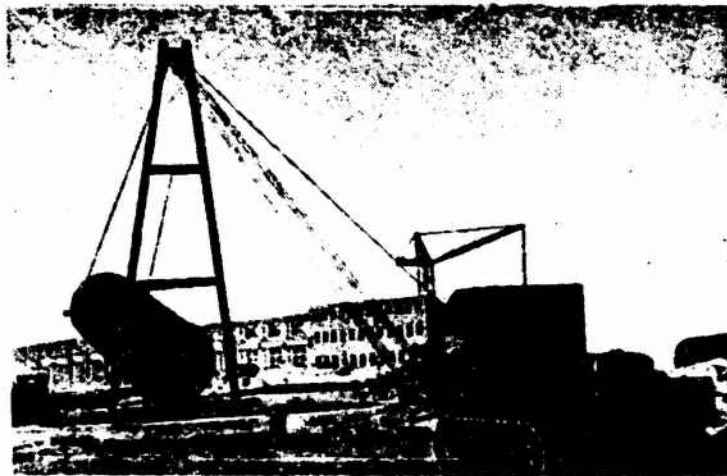

Fig. 7.15. Hoisting a roll using an A frame and tractor winch.

After the housing roll has been set up in the vertical position, it is moved around on the pallet so that its edge, after unfastening, falls at the design position for the assembly seam. This place is marked on the base.

Before the securing straps are cut, a single cable loop is put around the roll to keep the edges from suddenly unrolling after the straps are removed. An assembly ladder is used to cut the straps, starting at the top. The cutter is on the base when the lower two straps are cut. The released leading edge is pulled over to stops which are made from angle pieces and which have been fastened and then welded at designated spots on the base. The upper section of the released panel is secured with wire braces which run from the vertical stiffening column. A shackle is welded to the unrolled section of the roll about 0.5 mm up from the base (Fig. 7.16) and the tractor cable is attached to it; this unrolls the roll. When the tractor moves, tension is put on the cable and this causes the roll to turn and simultaneously to move along the base edge; the lower edge is clamped to the stops

(using jacks and wedges, if necessary) and is tack welded electrically.

After 5 to 6 m of the housing have been unrolled, the process is stopped and the roof panel is erected. A crane on the outside the storage tank is used to set up flat roof panel sections on storage tanks up to 5,000 m³ capacity. One end of the panel is connected to a central point in the roof which looks like a bridle around the central support column. Plate catches help to connect the other end to the upper edge of the unrolled section of the panel, after this, the process of unwrapping continues. The shackle is welded to a new spot. The tractor moves the roll. The lower edge of the unrolled panel section is tack welded electrically to the base. Unrolling the strip another 4 to 5 m, the next panel is set in, locking its radial edge into the preceding one.

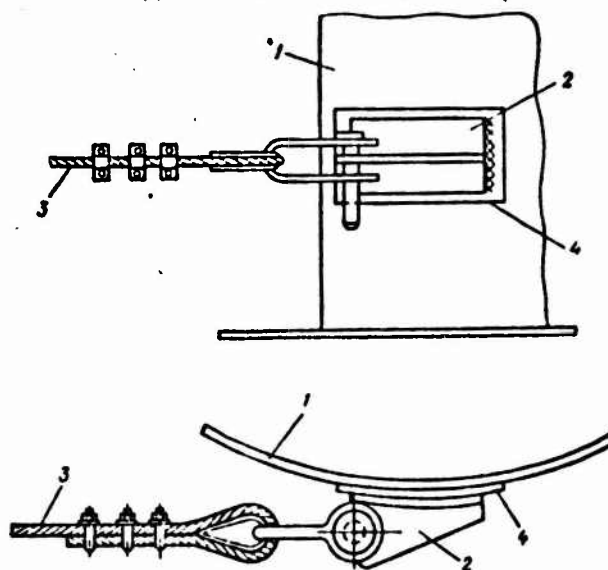

Fig. 7.16. Shackle for attaching the hauling cable.
1- housing; 2- shackle; 3- cable; 4- sole plate.

The process for erecting housings and spherical roofs for 10,000 and 20,000 m³ storage tanks differs in several respects from what has been described above. Since the housing for large scale storage tanks is delivered as a double or triple layered

rolls, these must be positioned on the base edge at the spots where unrolling will start. An assembly support column with the central roof panel attached to it is set up at the base center. The support which is the framework for winding the strip comes to the assembly site inside the base roll. The column height is a function of the roof radius, construction volume, and the actual datum mark height for the foundation center. The central roof panel is connected to the central column via a bridle with adjustable screw fasteners which makes it possible to lower the cover into its design position smoothly or to release the column easily during disassembly.

A crane sets up the column and panel. The lower end of the column is fastened to the base with shackles. The upper section is reinforced with bracing wire and threaded tightening devices so that the position of the column can be adjusted during the assembly of the storage tank. The vertical position of the column is adjusted by several plumb lines which run from the central panel to a line marked on the base.

When erecting 10,000 and 20,000 m³ storage tanks, housing strips are unrolled in succession. Despite the fact that the thickness of the lower housing belts is 14 mm, one 80-100 HP tractor can satisfactorily handle the unrolling. The strip is unrolled and its lower edge is tack welded to a mark, just as in the case for lower capacity storage tanks.

Spherical storage tank roofs use 32 sectional petal forms for 10,000 m³ storage tanks, and 48 forms for 20,000 m³ storage tanks. Each section, depending on the shipping conditions, is delivered to the area in two sections. Before assembling the roof, these parts are collected into one petal form on a special jig where a 150 mm pitch is indicated by an arrow indicator.

The next section of the strip is unrolled after 7 to 8 m have been released. Then assembly of the stiffening ring starts. The sectional pieces of the stiffening ring are about 6 m long and weigh 0.6 to 0.9 T. Catches help to connect stiffening ring members to the upper housing edge. The internal section of the members is supported either by a light column resting on the base or by support brackets temporarily welded to the segment. Plumb lines check the vertical condition of the housing.

Assembling spherical roof sections differs from assembling flat panel roofs not only because of the large sizes of the panels (the length runs about 17 or 20 m, and the weight is 1.7 to 2.5 T) but also by the fact that thrust forces are present. A boom derrick is used in assembling the roof petal forms; this helps to install panels close to the designed location (Fig. 7.17). Four or six slings, the ends of which connect with fastening shackles welded to the panel at the factory, are used for hoisting. The plumb lines check on the vertical position of the assembled column. In case the column deviates from the vertical, it is corrected by loosening and tightening the proper wire-braces.

The spherical roof panels are installed at a rate which depends on how much housing has been unrolled and stiffening ring assembled. Each panel is fitted beforehand with assembly bolts around the central ring, then after being dropped down, they bear against the angle brackets in the stiffening ring. If the edges of two panels are properly aligned, the gap can be eliminated by screws or wedges. After this, the butt strap joints are welded at those points where the radial and circular elements meet, the projecting part of the roof covering is clamped to the preceding panel and tack welded along its entire length.

It is relatively simple to close up one vertical butt joint in storage tank housings with capacities up to 5,000 m³. The starting and trailing strip edges as a rule are connected by a lapped joint. The proper cylindrical housing shape is attained in

this zone by applying successive wedge clamps along the edges and by pulling on the separate butt sections with the tractor cable. In some cases, short channel beams are set up at the butt section to get the required shape. They are attached to the housing by welded fasteners and wedges. Usually the more complicated methods (threaded tightening devices made up as pipes) are not used on the housing butt joint in storage tanks with capacities under 5,000 m³.

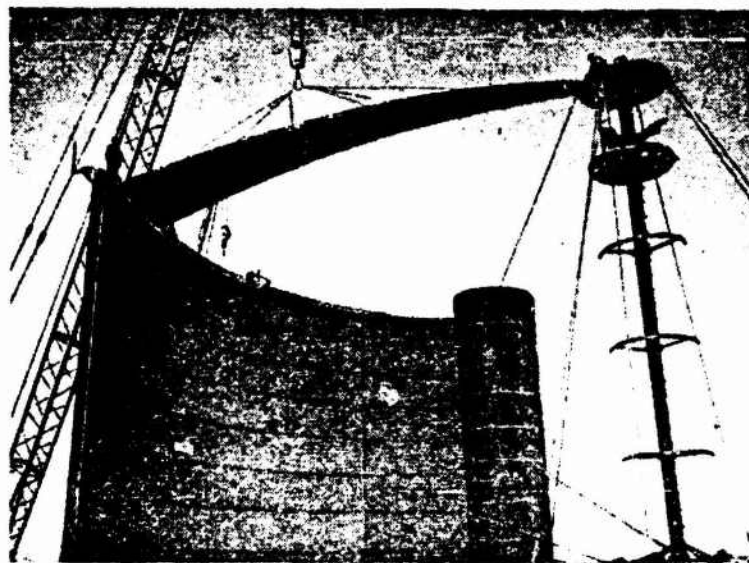

Fig. 7.17. Erecting the stiffening ring and first spherical roof panel in a 10,000 m³ storage tank.

In 10,000 and 20,000 m³ storage tanks the vertical housing joints are lapped because of the higher plate thicknesses. After assembling and welding the intermediate joint, the process of unrolling the strip continues in the normal manner.

Because they have some amount of rolled deformation the curvature in the edges of the thick lower belts is changed for the final locking butt joint. The edges can be shaped either by reverse bending the strips in a direction opposite to the rolled deformation by using vertical pipes, a heavy duty clamp and a tractor, or else by applying to the edges a bending moment opposite to the rolled deformed sections (Fig. 7.18).

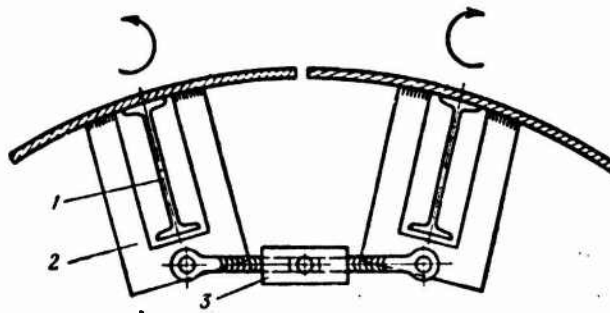

Fig. 7.18. Connecting the housing butt joint by applying a bending moment.

1- vertical stiffeners; 2- securing clips; 3- threaded tightening device.

In addition to this, in joining the edges at the joint, the material allowance on one of the pieces must be cut off in the sequence shown in Fig. 7.19.

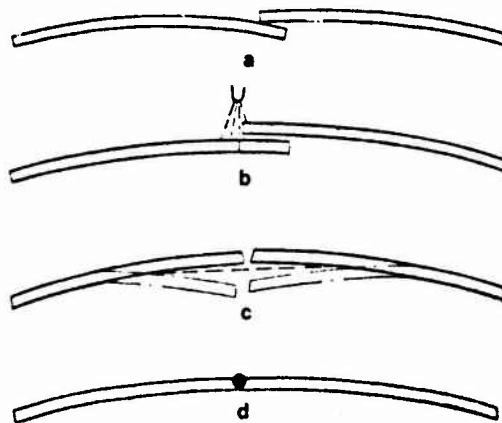

Fig. 7.19. Joining vertical edges at a housing butt joint

As they come together, edges which have taken the position in a, after being drawn up, take the position in b; the edges are reinforced with assembly strips, then the inside edge is cut by following a line marked on the outer surface. Position c shows the edges matched up at the butt joint. When welding thick plates manually, the edges are bevelled, then the joint is welded on both sides (position d).

A guard rail running around the storage tank's entire perimeter is put on spherical roofs. An overhead cradle is set up to weld the joint between the upper housing edge and the roof; this rests on rollers against the roof's edge or the handrail. The cradle is fastened by hinged tie rods to the stub welded in the middle of the roof. The cradle is used to set up and weld the outside stiffening struts.

Roof installation is complete when the closing panel is installed. The seams between the housing and the base are welded, depending on how much the roll has been turned. The overlap joint (locking seam) is welded on both sides with continuous welds from the lower housing belt to the upper or from top to bottom, reversing the steps.

The internal and external circular seams which join the housing to the base are made in two reversed passes. Welding is done by several welders (two or four) each on one side and they must start along the surface at the same time and move in one direction (for example, clockwise). The welder inside the storage tank must lead his opposite number by 300-350 mm. The second layer is put on before the first has cooled.

Welding joints within the roof and to the housing is done either manually or is mechanized.

After completing assembly of the roof and welding all joints, the central panel in storage tanks with spherical roofs is connected to the bridle and the bridle to the assembly column. The support column and bridle are then removed through a manhole.

Fittings and ladders are assembled to the storage tanks, tests are made, then the tanks are painted.

Assembling Storage Tanks with pontoons or Floating Roofs.

Conforming with industrial manufacturing methods and modular construction assembly techniques, pontoons are supplied as follows. The pontoon base is manufactured at the factory as a rolled strip made up into a single roll with the storage tank base. Pontoon ring segments are delivered as large assemblies which are still suitable for transshipment.

The technology for assembling pontoons requires that the base be manufactured with a diameter which does not exceed the inside outline of the ring. Ring sections are delivered as locked box sections in which all seams are welded and inspected for tightness at the factory.

The pontoon is assembled in the following sequence. The base of the pontoon is unrolled on the storage tank base immediately after the latter has been assembled. There is a 2760 mm wide hole in the center of the pontoon base to set up the central column. If the hole is cut during assembly, the central section is lifted above the storage tank base so as not to damage the latter.

The unfolded strips are set up at the design positions after checking the dimensions from the center with a compass and attaching fasteners around the periphery. Base sections are connected together with the fasteners. The joint sections in the pontoon ring are marked out on the storage tank base and the circumference for the proper positions of the internal connection points is marked out on the pontoon base. Then in the usual order, the housing rolls are set up first, then the central column; the housing is turned about and the frame and panel roof is erected.

Pontoon ring segments are collected together at the same rate as the housing is unrolled. A pipe laying crane brings them

to the base through the unlocked housing section and they are set up by the same crane used in assembling the roof. Another possible method is where the loading box is brought inside into the storage tank by the assembly crane above the housing.

Segments are distributed around the periphery of the housing to points marked on the base. Before each segment is set in, all tack welds to the pontoon base are removed and this condition is checked by lifting the edge with a crowbar.

Segments are welded together and to the pontoon base only after carefully checking the segments for proper positioning. All joints are lap type, a planned feature for connecting the parts of the segment elements. The assembly seam in the pontoon base is welded at the same time. Seams are checked by coating them with a soapy solution and then subjecting them to a pressure of 100 mm of water. Defects are marked wherever bubbles appear; they are rewelded and retested. A vacuum chamber is used to control weld integrity in the pontoon base. Special controls are applied to the assembly seams which tie the segments to the base and between the base strips.

After finding and correcting defects, the places where segments have been tied together are covered by two straps which follow the contour. A vertical ring 200 mm high is welded around the central opening in the pontoon base during assembly.

At present, open type pontoons which were developed in the USSR are used. Their construction is different in that there are no locked ducts around the pontoon's periphery. There are two construction versions for the open type pontoons: they have either circular ribs or radial ribs. In the former case the ring wall around the pontoon's edge is connected to the circular rib by short radial ribs which forms a stiff ring around the pontoon's periphery. In the latter case, the radial ribs meet

at the pontoon's center and the pontoon base is divided into a number of compartments instead of into circular elements.

In building open type pontoons not only is the central section manufactured by industrial methods but also the entire base strip. Rib parts come packaged. They are set up at the design positions, then the corner gussets are set up in the required locations and these are welded to the base, making tight corner seams on one side.

To support the pontoon when it is in the lower working position, rotating angle brackets are welded to the storage tank housing. The supporting structural elements for a pontoon are shown in Fig. 7.20. The accuracy of the upper datum of the angle brackets (+ 1.8 M) is checked by a level at installation. If there is a control support column in the storage tank, it has a support ring with struts at its base; this reinforces the central section of the pontoon. All brackets rotate and bear against the housing before the pontoon is raised. All remaining assembly work on the pontoon is completed after finishing the structural elements in the storage tank, so that the tank can be filled with about 2 m of water. Then another inspection is made to be sure that there are no tack welds between the pontoon and the tank base.

The pontoon floats when the tank is filled with water. When the lower pontoon surfaces rises 50-100 mm above the top surface of the datum bracket, the water flow is stopped. The brackets rotate and orient themselves with respect to the tank's center and are then fixed in this position. The central pontoon ring is secured to the central column with three or four lines. Then the tank is emptied. The pontoon edges bear against the brackets but the center remains suspended. Welding pontoon seams

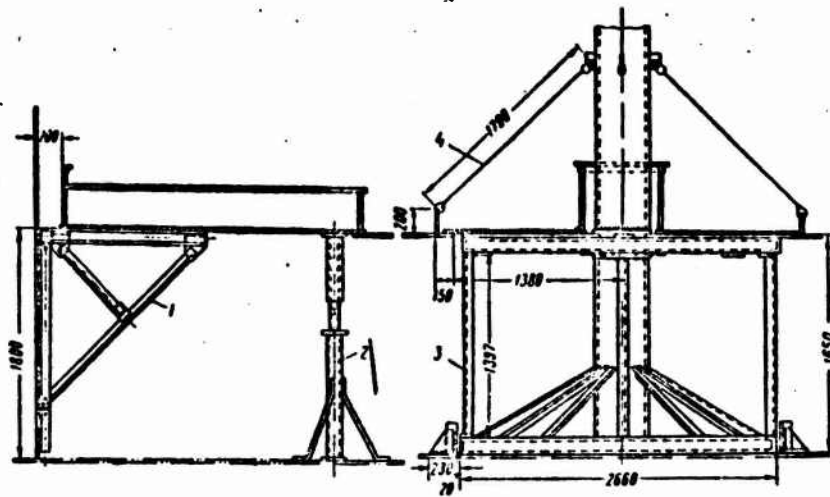

Fig. 7.20. Supporting structural elements for a pontoon
 1- rotating bracket; 2- internal column; 3- central support ring;
 4- line.

on the underside is done in the space under the pontoon and struts are set up under the internal surface of the pontoon. Support struts are welded to the base while the top is held level with the brackets, either by prepositioning the pontoon with jacks or by special threaded devices. The hole at the center of the pontoon base is reduced by welding in a sheet metal circular element. A cylindrical ring which looks like a manhole is welded at the center. Holes are cut in the pontoon and parts are reworked so that a sampler can be used and a skylight and measuring access part installed.

Struts in open type pontoons are reinforced with unions formed into the pontoon base. An assembled pontoon is checked by test volumes. The check is made to see that all seams in the visible section of the base were tight and there was no water in the double bottom section (in closed type pontoons). A subsequent check is made using test probes installed in each segment for this purpose.

Finally, a check is made on joint tightness with test volumes after dropping the pontoon.

While the pontoon is being checked for its floating action and horizontal position, the circumferential clearances at each belt is checked. In making the preliminary check, housing geometry should not exceed the limits set forth in SNiP III - B.5 - 62.* In addition, a check is made on the accuracy of pontoon moment around the central column and on the vertical sections of process equipment running across the pontoon. If any sort of trouble is encountered while operating the pontoon, tests are stopped and are not resumed until the cause of defects has been ascertained and eliminated.

Floating roofs are similar in construction to closed type pontoons. The basic principles governing their assembly are the same. The differences in assembling tanks with floating roofs can be reduced to the following. The upper section of the housing is reinforced by a circular area the size of which is determined by how much of the housing is turned and lifted up, section by section, by the crane. There is no hole in the center of the floating roof because there is no central column. In some types of such reservoirs provisions are made so that support struts can be put down through special access parts in the cover to support the central section of the roof after it is first lifted up by the water. Special hands are installed in the upper portions of the struts which change themselves to a diameter larger than the hatch diameter after the struts have been dropped down. When the roof is lowered completely, its central section rests on the struts. After the water is drained, the struts are secured to the tank's base by welding rod type braces. Seals are installed in the circular area, after finishing the assembly and welding of the pontoon on the floating roof.

* Directive 2130

Erecting Storage Tanks Which Have Spherical-Cylindrical or Momentless Roofs

In cases where storage tanks have spherical-cylindrical roofs (DISI) or lightweight, momentless roofs, the basic sheet metal parts (the base or housing) come in as rolls and are erected in the normal way.

Toroidal-spherical roofs are set up by assembly the petal type parts, one after the other, with a crane. In the center the petals rest against the upper ring of the assembly column, while at the perimeter latches are used to connect up with the upper housing edge. After matching in the proper sequence, - the petals are tack welded electrically at their proper places as well as to the preceding petal.

Intermediate structural supports are used in assembling roofs with large spans and these are supported at the center petals. Pains are taken to set up the installation accurately so that the anchor bolts around the housing can be tightened uniformly. The point where the base and housing meet is secured by anchor bolts in those storage tanks which have spherical - cylindrical roofs. The bolts are embedded in a buried concrete ring. They extend over the base datum line by 450-500 mm. Anchor bolts are boxed over with wood during assembly of the rolled bases and housings to protect them and the rolls from damage.

The petal forms for the spherical-cylindrical roofs look like thin-walled (4-6 mm), flexible sections, 6-8 m long, rolled in a compound curve so that there is a larger radius in the center and a smaller one at the edge. Such types of petal forms are installed but the designed curvature throughout all parts of

of the roof is controlled by the following methods:

- 1) by individual petal forms;
- 2) by assemblies put together on machine stands;
- 3) the roof is totally assembled in a lower position.

The first method requires the least amount of preliminary work. It is usually used in erecting individual storage tanks, when there is no intention of building assembly stands or other devices. This method is shown in Fig. 7.21.

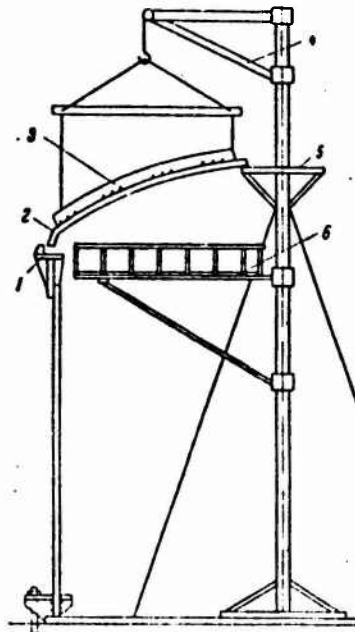

Fig. 7.21. Erecting individual petal forms in a spherical-cylindrical roof.

The petal forms, 2, are received from the factory in packages and are laid out on the base. A jig, made from a 150x8mm strip, is tack welded in the center of each petal form. The jig helps to maintain the required petal shape during assembly. Hoisting cables are attached to it. The petal forms and jig are lifted up, one after the other, by crane or by a rotating boom, 4. Each petal form is set on the upper periphery of the stiffening ring going around the storage tank, 1, and the center section goes against the circular support, 5, which is on the central

assembly column. In the radial direction, the edges of adjacent petal forms form lap joints. The process of installing roof elements accurately is facilitated by fasteners set in the upper and lower rings. Wedges and angles formed and welded into a pocket press and hold down the edge against each, adjacent one, and is then tack welded. The locking (last) petal form is set up to form a lap joint with the first and last plate. The plate joints are welded intermittently along the underside of the tank using the special rotating staging, 6. A light, stock ladder is used to weld the seams from above.

The assembly is complete when the central, circular roof plate and the upper ladder flight have been installed and the central column removed. Fittings are then installed on the central plate. The complete tank and all seams are then tested.

A special stand is set up at the assembly site to assemble the spherical-cylindrical roof using large assembly sections. It is set up on the base so that assembled sections can be hoisted conveniently by a rotating boom. The stand is built in such a way that its upper section matches the petal form curves. Individual petal forms (or their sections - lower and upper) are set up on the stand and are pressed down by threaded or wedge type tightening devices.

The annular seams between the lower and center sections are welded first, then the radial lap joints. The finished assembly is released from the stand and then hoisted to its installed position. A crossarm with four ends is used to hold it steady during the hoist. Sometimes, temporary stiffeners are welded to the assembly edges. Supporting the assembly and finishing the assembly work is done the same way as in the first case. Sometimes, the central column is left in the tank welded to the roof but it must be left free to move when the roof lifts.

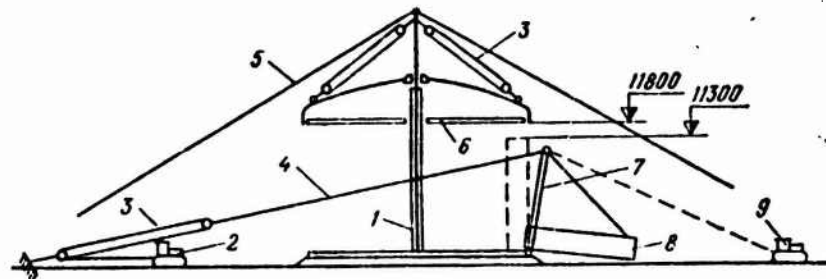

Fig. 7.22. Erecting a roof assembled below.

1- telescopic mast; 2- tractor; 3- block and tackle; 4- cable; 5- stays; 6- spacer; 7- drop boom; 8- roll; 9- braking tractor.

If the spherical-cylindrical roof is to be assembled in one piece on the ground (Fig. 7.22), a mast is set up on the unfolded base, then the housing template is set up around it and the entire roof is assembled, except for the central sheet. The assembly spreaders are unfastened when it is ready to be hoisted, and is lifted about 0.5 m above the housing using blocks and tackles. When in this position, it is secured to the mast and braced. Then the housing is raised next, the roof is lowered into the designed position and secured.

After unrolling the housing, the upper edge must be in contact with the roof's underside. They are tack welded together. This method of assembling the roof is somewhat complicated. It is recommended only for tanks with capacities up to 700 m³.

In erecting storage tanks which have momentless roofs, the base and housing are erected in the normal manner using rolled pieces. A stiffening ring made from one, two or four angles, depending on tank capacity, is set up (in sections 4-6 m long) on the upper inside edge of the housing, depending on the degree of stage erection. The sections are welded to one another, then

clamped against and welded to the housing. This element receives the roof's radial loads. A permanent column which has a conical canopy over its upper section and whose reference level meets the design requirements, is set up at the center of the tank and is secured by bracing wire.

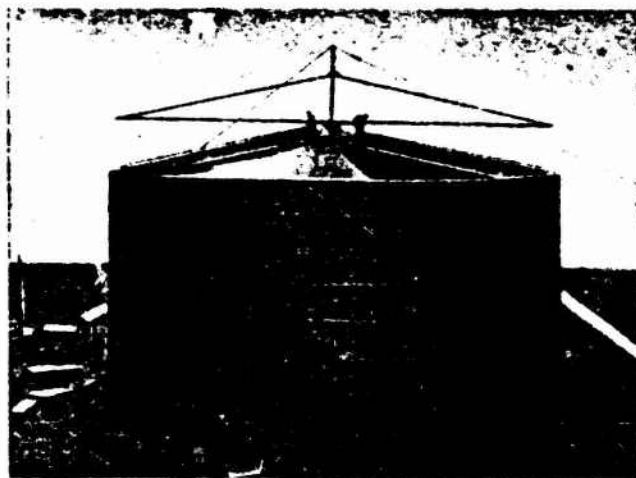

Fig. 7.23. Erecting a momentless roof using two crane booms.

Special solution methods are needed to hoist up the very flexible thin-walled sections in the roof which are made from steel 2.5-3 mm thick. During the assembly process, they are usually cut out from rectangular strips delivered from the factory as rolls. The petal forms are hoisted by a crossarm with several ends or else temporary stiffeners are welded to it. Cranes or rotary girders - crane booms (Fig. 7.23) - are used for the hoisting. Two petal forms are assembled in parallel, one on each opposite side. In setting the petal forms into their design positions the hoisting hook is not lowered until the wide section of the petal form is welded to the ring on the upper edge of the housing and the central piece to the canopy. All petal joints made with the housing, canopy or between one another are lapped.

The process of assembling, clamping and welding joints between the petal forms in momentless roofs is more difficult because of their extreme flexibility. A rotating platform is set up to do this work.

§ 6. Erecting Trench Type Storage Tanks

The following sequence of work must be followed in erecting trench type storage tanks:

digging the foundation and setting up a sand cushion with an upper waterproof coating;

unrolling envelope strips and putting an anti-corrosion coating over them;

setting up the strips in the designed positions, welding seams, and then testing them for tightness integrity;

setting up trusses and erecting and frames and ties;

rolling up the envelope edges around the frames and welding them to the housing;

erecting the storage tank cover;

installing fittings, testing, waterproofing and filling in the earth.

Construction of the foundation under a trench type storage tank starts with the removal of the earthen vegetative layer by a bulldozer. Then the foundation itself is made using bucket excavators or dragline cranes, scrapers or scrapper-loaders. A bulldozer moves the excavated earth to a temporary storage area. The last 10-15 cm of surface from the bottom is removed manually to meet design requirements. The foundation surface is covered with a sand cushion 100 mm thick. Moist sand in the cushion is compacted by a vibrator or rammer. The sandy cushion surface is then coated with a waterproof layer of sand mixed with asphalt (residual oil, dehydrated petroleum). Thickness of the waterproof layer is 100 mm. It is first put in at the lowest portion of the foundation and compacted by rammers.

The foundation bottom must have a 0.3% grade. A metal inspection gutter is set up along the foundation's axis, on the same grade.

The ground is excavated at various spots along the upper slope of the foundation and reinforced concrete (either monolithic or assembled) foundations are set up so that they will be under the support columns. A pipe laying crane or a regular crane is used for this work. Any gaps around the foundation are filled in with earth and then carefully compacted. After this work is done, the area is levelled to prepare a place for erecting the steel lining for the storage tank.

The tank lining comes from the factories as rolled strip all of which has been welded automatically. The thickness of these steel liner plates is 4 mm. The number of rolls can vary. When laying down strips in a transverse direction to the trench, the entire lining, which can weigh up to 58 T, comes in six or seven strips, rolled into one or more rolls. It is most convenient to use only three strips when putting down a transverse covering. In practice, all the strips can be set into one roll.

If cutting is required and there is sufficient space at the site, the rolls are rolled out alongside the foundation. Then two tractors - one hauling and one braking - move the pieces across the foundation, in sequence to their proper installed position (Fig. 7.24). A crossarm is used to fasten the cable to the strip's end face. The strip is moved over the waterproof layer but contact is kept to a minimum to avoid damage. A lap joint of about 40 mm connects the strips.

After the strip is dropped, it makes intimate contact with the waterproof layer throughout the entire trench. Remaining strips are handled in the same way, except that the edge of each strip overlaps the other. Experience has shown that the strip edges make intimate contact with one another and there are practically no places where additional lining or wedges are required.

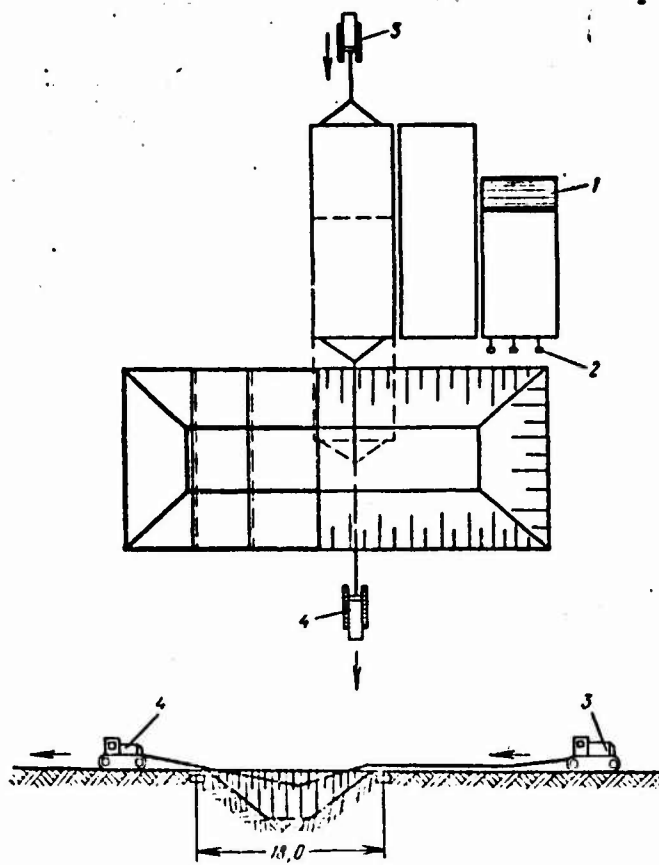

Fig. 7.24. Erecting liners for trench type storage tanks with capacities up to 5,000 m³ using rolls laid down transversely. 1- roll; 2- anchor; 3- hauling and braking tractors to handle the sheet.

The lower surface of the strips are covered with a waterproof coating during assembly (a primer and one or two layers of asphalt). Usually paint sprayers are used to apply the coating when the roll is unwound. If the space at the edge of the storage tank is inadequate for arranging the strips, they can be unrolled one by one at the tank's edge. Then each strip is moved to the installation spot. This operation is carried out by two cranes, one for lifting up the strip by its ends and the other moves it

along the trench when the booms are turned. The rear edge of the strip slides along the previous strip. Logs or boards are put under the leading edge of the strip so there is no damage to the waterproofed layer. Each strip is fastened to its neighbor by tack welds or other fastening devices.

In the process just studied, it is very difficult to erect the lining end faces. The strip must make two bends in the foundation corners and must line up with the edges of the adjoining strip. The end faces of the strip are cut out at the assembly site before being set down. The bends are made by dragging weights (for example, a 2 T concrete block) across the strip or by applying wedges locally.

Erecting the storage tank liners in longitudinal strips (Fig. 7.25) differs somewhat from the assembly methods already covered. The strips can be either put down lengthwise over the storage tank or on edge and then turned over to the designed position. The proper side of the strip is covered with a waterproof coating as the rolls are unwrapped. Weld integrity is checked by pouring kerosene over the lapped joints which have been welded on both sides. Then a depression* is cut out with a template. The lining strips are dragged into position within the trench by two tractors or tractor winches. The center strip is unrolled in one piece by the end face strip, it is placed in the trench and then properly positioned.

When installing a lining made from three strips, the overall work difficulty and the time required is reduced. The time required for making the welded joints is reduced significantly.

Once the strip is erected, the joints are then welded. The edges, as a rule, make intimate contact and do not require heavy clamping. Compressed air is used to clean out sand, earth or

* In this case it is the line intersecting the lateral and end sections of the lining.

waterproofing compound which might become lodged between the lapped joints during assembly.

Welds in the transverse strips are welded either manually or semi-automatically and the proper mark types of electrodes are used to get tight seams.

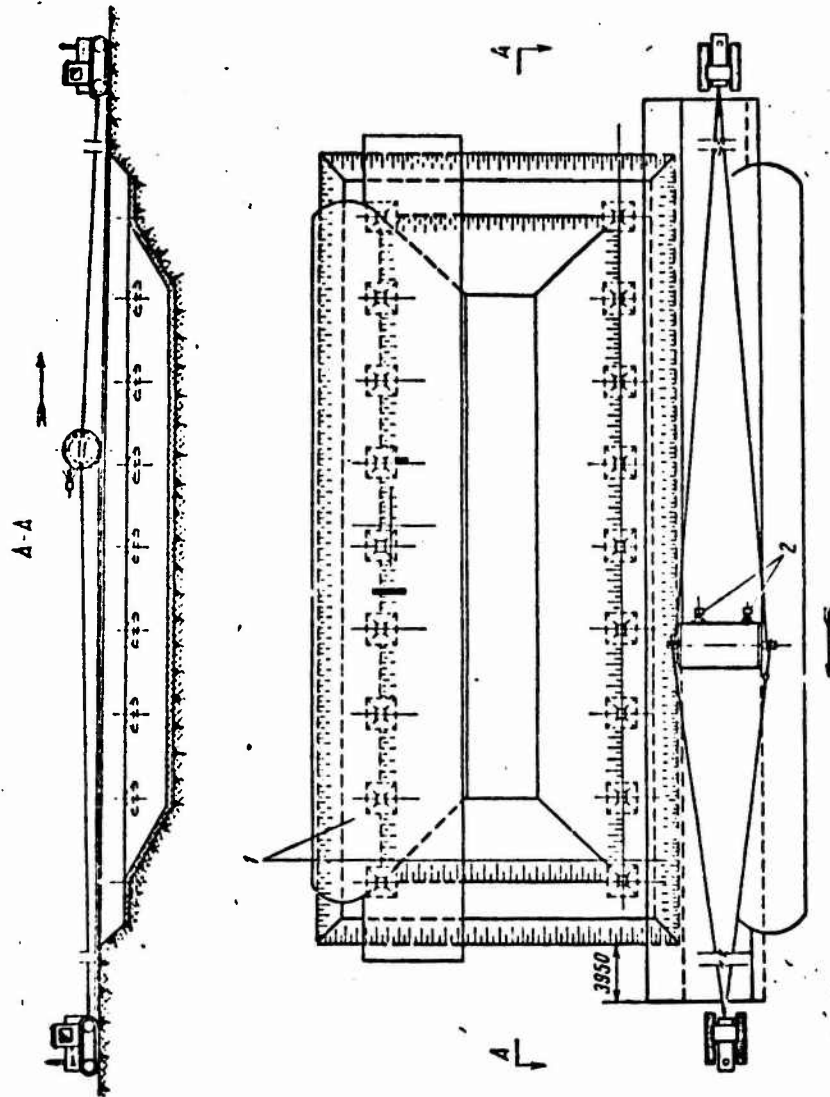

Fig. 7.25. Installing liners using longitudinal strips
1- lateral strips of the liner; 2- paint spray gun.

When setting down strips lengthwise, seams can be welded automatically with a TS-17M and with flux.

A vacuum technique is used to check the tightness of welded seams in the tank liner.

After welding has been completed and joint integrity checked, places for setting up trusses (over the foundation sites hidden by the lining) are marked out on the lining and locking angles are welded. Usually a crane with a 30 m boom and the proper load capacity is used to erect the trusses over the covering. Trusses are supported by chocks fixed to the lining and the foundation underneath.

Trusses can be set up using two cranes located on each side of the trench. Once set up, they are secured with temporary bracing.

Ties and frames are erected by caterpillar or truck mounted cranes.

After adjusting and securing metal construction parts, the side walls are formed by bending up the free ends of the lining. The lining edge which has the transversely positioned strips is lifted up by a truck crane or else it is pulled around frames by a tractor on the opposite side of the tank. The drawn up lining is secured to construction framework.

The edge of the strip at the end faces of the wall is hoisted up by whatever means are suitable (sometimes by using an additional mast). After this, it is connected by angle inserts, then the curved surfaces of the lining in the tank corners are welded.

Somewhat more complicated side walls are formed when the lining strips are laid out lengthwise. In this case it becomes necessary to lift the entire edge of the strip along its 50 meter

length in the tank all at once. The design anticipates this work by providing a stiffening element secured by fasteners - pipes going to the edge of the strip and a series of light-struts (Fig. 7.26) set up on a frame and running the length of the wall. Tension cables running from the tops of the struts are secured to the edge of the liner. When tension is applied to the hoisting cables either by tractors or manual winches, all the struts turn simultaneously, then lift the edge of the liner up and clamp it to the housing. After this, the seams are adjusted, trimmed and welded at the depressions, then are tested for tightness integrity with kerosene. Reinforced concrete, sectional beams, 18 m long, are used as load carrying elements in the storage tank roof, and they rest against the guard walls. Hollow, reinforced concrete, roof slabs are placed on the beams.

The joints between slabs are sealed with cement. The top of the slabs is covered with 20 mm of cement and then sealed by a 100 mm thick layer of clay. The tank is then covered with earth.

In storage tanks made from metal the roof is made from separate panels. The panels are placed on trusses by crane and welded together and to the load bearing parts of the construction.

Roof joint integrity is checked by raising air pressure within the tank (when subjected to the hydraulic tests) and coating the joints with a soapy solution.

The final test of trench type storage tanks for strength and integrity is made with water. (For this, as mentioned above, liner, roof and assembly joints are tested for joint integrity). The storage tank is filled with water up to the design level for storing petroleum products, then observations are made on how the tank settles, construction behavior, water level and whether any water appears in the inspection gutter set under the lining along the tank's axis. The test lasts 72 hours.

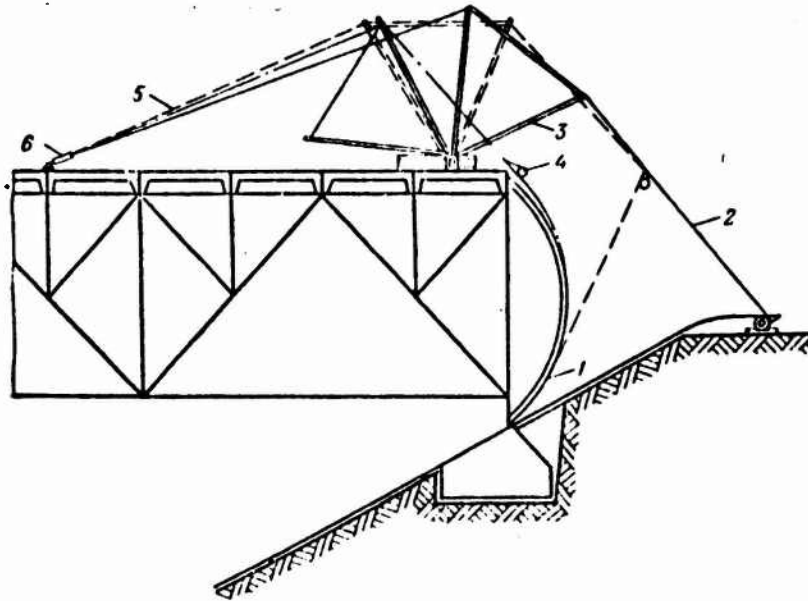

Fig. 7.26. Turning longitudinal strip edges with light struts.
 1- envelope; 2- hauling cable; 3- strut; 4- pipe for stiffness;
 5- cable to the tractor or hand winch; 6- lead block.

The drainage ring should not have any water. If some appears, it should be pumped out and then the rate of accumulation should be watched. If there are some joints in the tank which are not tight, the tank must be emptied, the envelope must be rechecked by a vacuum or else by pressurizing the envelope lapped seams with air to eliminate all leaks. After this, the hydraulic test is run again.

§ 7. Erecting Low Pressure Gas Storage Tanks

Erecting Wet Type Gas Tanks

At present, all wet type gas storage tanks in the USSR are made from rolled parts. Construction elements for the storage tank base and walls, as well as the telescopic wall sections and the float are manufactured at regular facilities using the technological processes discussed previously.

The gas storage tank base is delivered as a roll which contains one to two (for volumes up to 3,000 m³) or three to four (for volumes over 6,000 m³) strips to which thick edges are normally welded. In certain cases, the edge sections of the base are delivered in segments. The wall of a gas storage tank is similar to the housing in a petroleum storage tank. The thickest plates are in the lower belt - these are 12 to 14 mm thick; the thickness of the upper belts is 4 to 5 mm.

The building elements for the circular hydroseals in the telescopic and float sections as well as the circular stagings are delivered as assemblies. These building elements are then made into larger units at the assembly site.

The thin covering for the float roof usually comes in as individual plates. Sometimes rolled products are used in assembling a roof covering. The thicker edges for the roof come as segments which have been precut at the factory.

In getting an area ready for erecting a gas storage tank, construction work is first finished, the reinforced concrete foundation is checked, all metal construction items are received and stored in the proper order, areas are set aside for assembling elements into larger units and the electric power and water supply lines are installed.

The base for a single section small gas tank is erected in the same way as regular storage tanks. Rolls for gas storage tank bases 6,000 m³ in capacity or more, which have three or four sections, are successively unwrapped and positioned in the designed positions on the foundation, then the seams are welded.

The base is marked off with a steel tape measure or by a special stretched cable, or by a rigid compass fastened at one end to the center of the base with a pin. Concentric circles

are laid out around the base and these match the outside radii of the storage tank wall, the inside and outside edges of the support beams, the outside radius of the float wall, and in the case of gas tanks with three sections - the outside radius of the telescopic section. In addition an axis is marked on the base which passes through the base center and the center of the ladder. When doing all this, attention must be paid to the location of the gas receivers. Points are marked on the proper circles for the positions which fix the starting edges of the rolls, the location for setting up support beams, the internal tracks and the support columns.

After the marking is complete, the rolls for the storage tank wall, the telescopic section, and float are set up vertically on the base. Rolls are lifted by a tractor and A frame or by a crane with the proper hoisting capacity (Fig. 7.27).



Fig. 7.27. Setting up rolls into the vertical position with a crane.

The usual practice is to unroll the storage tank roll on a pallet with a tractor. After unrolling 10-12 meters by crane, the first section of the circular staging and the internal telescopic section tracks are set up. Special assembly cradles and suspended stagings are used to prepare the staging, to weld the

brackets, and to secure the tracks. Subsequent staging sections and tracks are erected in the same way, depending on how much the housing and storage tank have been unwrapped.

Supporting I-beams are set up along designated marks on the inside of the unrolled storage tank housing and are welded intermittently. The support ring for the telescopic section to which several sections have been added previously is put on top. Markings for the telescopic section circle are transferred from the base onto the support ring before the next section is set in. In gas tanks with two sections, the telescopic section is then erected. After the telescopic section roll is lifted into the vertical position, it is placed on a 320 mm pedestal. The roll, together with its pedestal, is moved by the tractors close to the support ring and is turned around by the tractor by means of pulleys or sometimes by block and tackle. If this is done, the lower edge rests against the limit brackets on the support ring.

The upper section of the telescopic section wall is secured to the storage tank wall by temporary braces. Float tracks are installed in the upper part of the unrolled wall of the telescopic section and parts of the upper hydroseal assembly are installed in the upper section by crane. The position of the hydroseal is checked by plumb lines and then it is temporarily secured with braces to the upper section of the storage tank wall.

The roll for the float wall is unwound in the same way as the roll for the telescopic section, by a tractor and pulleys or block and tackle, if necessary. The lower edge is clamped to fasteners and secured with tack welds. The position of the upper edge is fixed by the braces which have been temporarily welded between the float and the vertical plate in the telescopic section's seal. Float struts are set up in the unrolled section of the strip. Preliminary support parts are welded to the struts to support the rafters which cover the float.

The float roof is erected with larger assemblies put together beforehand in a specially planned area. The rafters which rest against the fabricated wheels are put into their designed position,

then the rest of the roof elements are assembled. The nodal connections are welded after a complete check has been made. Then, the assemblies -- the roof sections are hoisted by a crane, or by special slings or cross members and are set into position (Fig. 7.28). The lower ends of the rafters are secured with bolts, and these are then welded to the support stages on the telescopic section struts, while the central part of the roof is calmped and welded to the central ring which has been reinforced with temporary, assembly-type struts. Gaps between the assembled roof sections are fitted by purlins and ties.

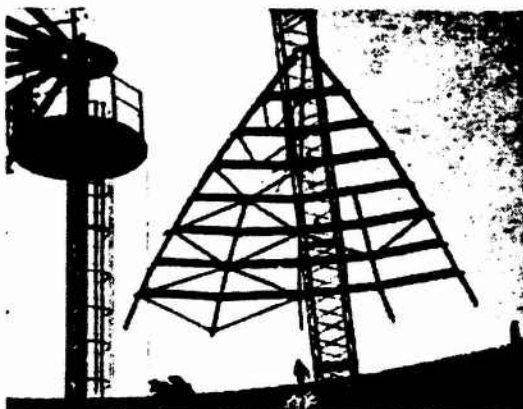

Fig. 7.28. Assembling a reinforced float roof section.

The construction slope for roofs during initial assembly and installation should equal:

for gas tank volumes of 100-600 m ³	50 mm
" " " " " 1,000-3,000 m ³	75 mm
" " " " " 6,000-20,000 m ³	100 mm
" " " " " 30,000 m ³	150 mm

The construction slope comes from setting the central roof ring on the assembly column to match the height of the datum mark set by the design. The edges of the float roof are assembled at the same time that the larger units are being assembled in the jig. The thin sheet stock for the covering is delivered to the top in a package or else as a cluster of assemblies made up of several sheets welded together below. The roof cover is welded on the spot. All fittings in the float roof (access holes, cowls, lights) are welded just to the cover.

Stagings are assembled to the float roof and loads are distributed around them. The loads which are to be installed in the lower section of the float wall are passed down by crane through an opening in the roof.

Balconies for the staging in the telescopic section support ring are set up and welded together in large assemblies.

The outside tracks on the gas tank are erected from panels which are two vertical sections tied together with collar beams and ties. The panels are assembled ahead of time on racks near the gas tank. The panels, which are quite high, are then hoisted up and set in place by one or two boom-type cranes. The hoisting cross member is not attached at the upper ends but a same point above the panel's center of gravity; this makes it possible to use cranes with booms smaller than the full panel height.

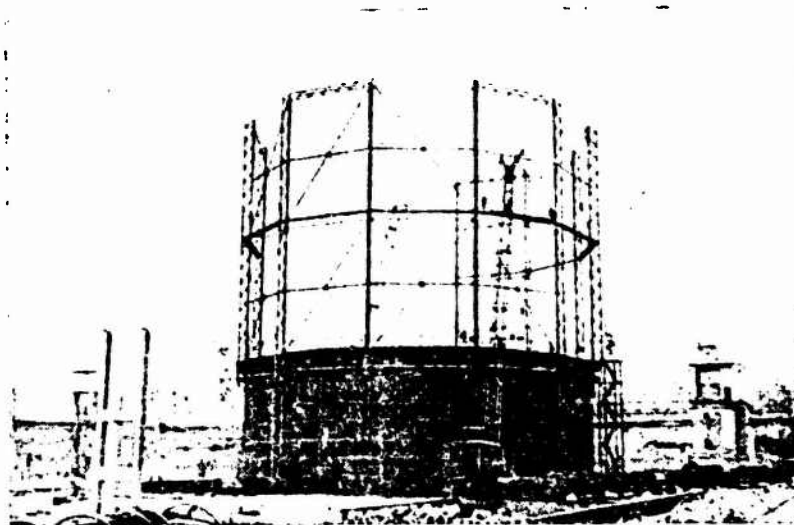

Fig. 7.29. Erecting external gas tank tracks.

Each external track panel is set on its own support and is affixed to them; however, the upper section is held loosely with four bracing wires. The bracing wires keep the tracks straight. A theodolite and plumb lines are used to check the position of the panels within the design. Purlins and ties are set up in the spaces between panels, then all joints are welded. Erection of tracks is shown in Fig. 7.29.

A crane moves the upper and lower purlins to the installation spot and then they are secured by bolts; this makes it possible for them to be adjusted to the tracks. A gas standpipe is installed in the float roof before the outside tracks are assembled.

We should acknowledge at the present time an improvement suggested by assembly man V. F. Bargakov (Fig. 7.30) in which all the walls can be unrolled simultaneously. It is based on the fact that all the main assembly work having to do with unwrapping storage tank walls, the telescopic section and the float along with all the associated operations can be done in parallel, i.e., unrolling the storage tank wall a total of 10-15 m before erecting the telescope wall, then the float wall is unrolled. Rolls are unrolled by one winch or tractor, and its cable can be easily directed to each of the rolls. A relatively small crane is used for the majority of the remaining operations. In large double sectioned gas tanks, three teams are used for the assembly work; each team has three or four fitter - assembly men ranging in four or five classes.

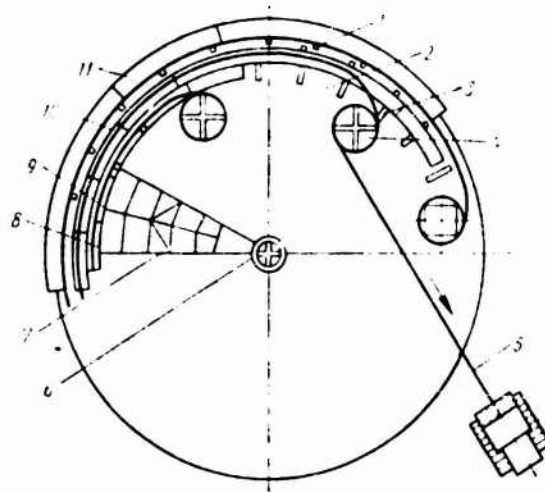

Fig. 7.30. Simultaneous unrolling of rolls for a wet type gas tank.

1- internal storage tank tracks; 2- base; 3- I beam sole plates; 4- float roll; 5- hauling cable on the tractor winch; 6- central assembly column; 7- float roof rafters; 8- float hydroseal; 9- float edge covering; 10- telescopic section hydroseal; 11- storage tank service area.

The first team unrolls all three rolls. After this, when the storage tank wall has been unrolled 10 to 15 m, the next phase of work starts when the second team sets up the internal tracks on the storage tank housing, the support beams under the lower support ring for the telescopic section and makes the necessary preparations for the first team to unroll the telescopic section roll. The third team prepares that phase which unrolls the float roll while assembling the float's hydroseals to the sole plates.

Depending on how much the storage tank wall has been unrolled, the circular stages, internal tracks, sole plates and the telescopic support ring are then assembled.

As the telescopic section walls are unrolled, the internal tracks, the large, assembled hydroseal sections and the sole plate hydroseals are installed.

As the float walls are unrolled, the support struts and cover are installed. The quality of the assembly work is monitored constantly. Inspected sections are connected at the top with temporary spacers; this increases overall rigidity and keeps all assembled parts from moving. The lower edges of the strips are tack welded electrically.

In erecting gas storage tanks by this method, the intent is to coordinate all work to a maximum and to reduce the time required for completion.

During assembly the integrity of the base is tested by a vacuum chamber; tank and roof walls are tested by kerosene; and the hydroseals are tested by filling them with water. Overall tests on the gas storage tank are run with compressed air after the anti-corrosion films have been applied. At the same time

this is done, the operation of the moveable sections are checked, as well as joint integrity in the float and in the telescopic sections. The gas tank is tested for air leakage over a seven-day period.

When the overall tests are run on the storage tank, special attention is paid to how smoothly the sections are raised and whether it jams or is misaligned. The jamming can be detected either when the air pressure at the gas tank's inlet goes up while the fluid level remains constant, or when the air pressure drops while the float level remains unchanged. In case jamming is observed, the moveable sections must be lowered smoothly while the required pressure level is still maintained and the cause for improper operation is corrected.

Jamming can also be detected if the air pressure inside the gas tank drops while the float level remains unchanged. This type of jamming can be eliminated by increasing the flow rate of air into the gas tank while the float is still held at one level, and then raising it above the point where the jamming was observed. In any case, tracks and rollers are checked and the moveable sections are also checked for misalignment.

According to building standards the allowable misalignment in moveable sections in a gas tank is 1 mm/, of diameter.

Moveable gas tank sections may go out of commission for the following reasons: internal tracks are not vertical; curvature in the external track drive rollers; improper installation of rollers; distortion of the cylindrical envelopes in the telescopic and float sections; unsymmetrical distribution of preloads on the float; poor roller lubrication.

The wind reacting against the elevated sections also affects the clearance. The rollers can get separated from the track on the lee side and be tightly pressed on the opposite side.

Float misalignment can be caused in making a measuring survey of the water level in the hydroseals which run around the entire perimeter.

Inspections are made while the float is being elevated, and precautions are taken so that the steam manifold which supplies heating water to the telescopic section's hydroseal does not rub against the float wall. If the pressure within the float does not meet design levels when it is in the upper position, the float is preloaded with additional loads evenly distributed around the perimeter.

Welded seams in the elevated telescopic section and the float are checked by covering them with a soapy solution. Air leaks in the float and telescopic section walls can be detected by the bubbles which appear before these sections leave the water. The amount of air leakage can be found by the following formula after corrections are made for the barometric pressure and vapor pressures:

$$V_0 = V_t \frac{273(B - p_{\text{par}} + p)}{750(273 + t)}, \quad (7.9)$$

where V_0 is the normal volume of dry air (in m^3) at 0°C and 760 mm of mercury; V_t is the measured volume of air (in m^3) at a mean temperature, barometric pressure B (in mm of mercury) and a mean gas tank air pressure p (in mm of mercury); p_{par} is the partial pressure of the water vapor in the air at temperature t and pressure B (in mm of mercury); and t is the mean air temperature found by taking an arithmetic mean of the temperature in various places under the float roof (no less than three).

If the temperature difference between the beginning and the end of the test is small, p_{par} can be ignored.

In this case computations are done using the formula

$$V_0 = V_t \frac{273(B + p)}{750(273 + t)}. \quad (7.10)$$

During the seven day period for testing the gas tank, intermediate, monitoring measurements are taken each morning and air leakage is calculated.

Air leakage found at the end of the test is converted to a gas leakage by multiplying the air leakage by $(\rho_a/\rho_g)^{\frac{1}{2}}$ where ρ_a is air density; and ρ_g is gas density.

The gas tank is considered to have passed the integrity test if

the converted value for gas leakage over an uninterrupted seven-day period does not exceed 3% for gas tanks with volumes up to 1000 m³ inclusive, and 2% for gas tanks with capacities of 3000 m³ and above. The amount of air leakage is a function of the nominal gas tank capacity.

After the integrity test, the moveable sections are tested for how fast they can be lowered, and to do this, one of the inspection hatches must be opened slightly. Lowering speed must be 1 to 1.5 m/min.

The following technical documents are formally signed when the gas tank is delivered for operational use:

- 1) certificates from the manufacturing plant;
- 2) an acceptance document for the circular foundation and the man-made portion of the foundation;
- 3) an acceptance document for the anti corrosion protection provided on the gas tank's base;
- 4) a test document for the base;
- 5) a test document for the storage tank housing;
- 6) a test document for the hydraulic seals;
- 7) a document on testing the gas tank's sections and gas intakes for air and gas leaks;
- 8) an acceptance document for the manufactured portion of the lightning protection system;
- 9) a log on welding work with a record of atmospheric conditions at the time the work was done;
- 10) a set of working drawings which show deviations or additions to the design.

Assembling Gas Holders with Helical Guides

According to the standard designs for 1000 to 30,000 m³ helical gas holders, developed by the "Proyektstal'komstruktsiya" Institute, all basic sheet steel elements are made in the form of rolled billets. These elements are assembled as described above. However, it is necessary to observe all measures providing for high precision of the cylindrical shells since they directly serve as the base for attaching the guides.

The following methods are proposed for making the helical guides: bending on bending rolls with the billet set at a 45° angle to the axis of the rollers; bending on presses with the use of special dies and punches; bending on rolls with several billets arranged between flat sheets; welding guides together from separate elements.

The tolerances for making guides allow deviations of ±2 mm for each 3 m from the axis of the helical line.

Before mounting the screw guides on the walls, the outline of these axes and, at a distance of 400 - 500 mm, two more parallel lines are marked with punchholes. It is most convenient to make the outline while preparing the rolled billets when the sections are in a horizontal position. Accurate layout of the axes is very important since if the guides are not parallel, it is possible that they will jam in the rolls. The angle of inclination of the guides is 45° with a tolerance of no more than 5 mins.

The helical guides must be attached tightly to the shell of the lifts or bell. Liners are installed under the guides at places provided for in the plan. A helical guide is welded to the shell with solid seams with a leg of 3 - 4 mm along the entire length.

A variation in the distance between guides within the limits of 55 mm is allowed with their parallelism being strictly observed.

The paired rollers between which the helical guide is attached are important parts of helical gas holders.

The bearing plate of the paired rollers is welded to the upper surface of the upper hydraulic seal or to the cantilever area of the tank at points strictly determined according to a special template. A slot in the template covers the cross section of the helical guide. The point of welding the bearing plate is determined here. Then the frame with the paired rollers is installed on it and attached with bolts.

Assembling Dry Gas Holders

Gas holders with a flexible section are constructed according to the designs of the "Proyektstal'komstruktsiya" Institute designed for capacities of from 100 - 20,000 m³. The designs use the progressive Soviet method of the factory production of sheet steel structures -- shell, gas holder bottom, disc bottom -- in the form of rolled billets. The sheets are to be welded together, which has significantly changed the technique of assembling such gas holders.

The rolled wall billet is made of sheets 5 mm thick. The maximum length of the roll is 17.9 m.

The processes of assembling the bottom, raising and unwinding the wall roll are similar to those examined above.

A gas holder is erected on a sand base, covered with a hydrophobic layer having a conical rise toward the center. The bottom is unrolled, gathered together and welded together out of two halves. The thickness of the bottom sheets is 6 mm. The conical shape of the bottom is provided by changing the amount of overlapping in the connection between the parts of the bottom.

Several horizontal stiffening rings of channel iron bent in the plane of the wall are attached to it from the outside according to the manner of unrolling in order to strengthen the rigidity of the wall.

A well ladder, serving as a plane for turning the panels, is installed together with the shell. The wall is welded to the bottom with fillet welds.

The cover is assembled from channel or I-beam rafters, bent along the radius, between which channel steel bases are installed.

The frame is built up in disc structures, and then raised in place and welded to the gas holder wall by means of corner plates. The edges of the roof and then the roof decking plates, 3 mm thick, are laid on the frame and welded. The decking plates are welded together and welded to the frame with fused seams. Cranes or a system of winches are used for assembling the roof.

Hatches, the cable tension equipment control boxes, the gas collecting equipment box and lightning conductor are mounted on the roof. Underneath support beams, on which the disc rests in its bottom position, are laid on the bottom, according to the unrolling of the shell.

The bottom of the disc is unrolled from a rolled billet 5 mm thick. A ring -- the support drum, from which the I-beams of the bottom frame, connected with angle iron braces, extend radially, welded to the center of the bottom. From 1 to 3 ring-shaped stands of bent angle iron for mounting concrete weights are arranged on the same beams.

The flexible section of rubberized fabric is supplied by the factory in the form of a cylindrical collar ready for use. The collar is unwound from the packing material and suspended along the perimeter of the wall on steel cables. The upper thickened part of the shell is

fitted and attached on bolts to the ring-shaped reinforcing angle bar of the tank (Fig. 7.31, a). The lower thickened edge of the shell

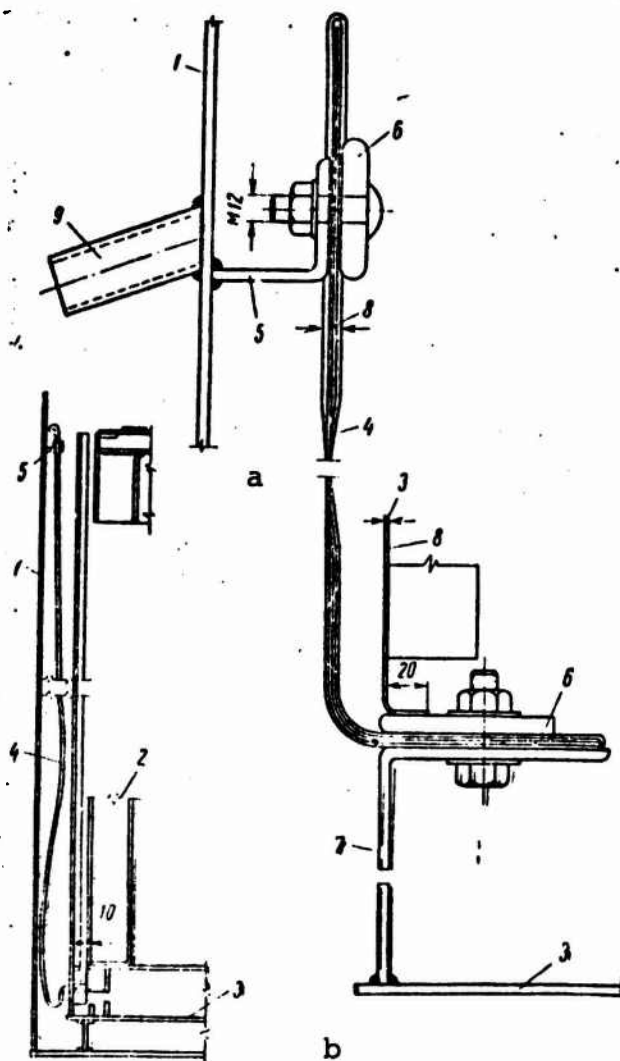

Fig. 7.31. Attachment of Flexible Section.
 a) Top, b) bottom units. 1) Tank; 2) Discs; 3) Bottom of discs; 4) Flexible section; 5) Angle bar attached to tank wall; 6) Clamping strips; 7) Angle bar attached to disc; 8) Protective wall; 9) Connecting pipe for draining off condensate.

also is attached on bolts to the ring-shaped angle bar on the edge of the bottom of the disc (Fig. 7.31, b). Holes are made at each point where bolts are placed in the shell. Owing to the multi-layered nature of the thickened edges of the collar, it is compressed and reliable sealing is obtained at the points of attachment. In addition, the points of contact between the shell and the metal where they are attached are smeared with glue and covered with strips of uncured rubber.

A cylindrical protective wall is installed around the perimeter of the disc. Assembly ends by tightening the cables of the system which provides for a horizontal position of the disc as it moves through the rollers. Gas holder testing is performed according to special instructions.

§8. Manufacturing and Assembling High Pressure Tanks and Gas Holders

Manufacturing the Structures

The factory production of the basic unit of tanks -- the shell -- consists in imparting a spherical shape to flat steel sheets and cutting off the edges with the appropriate finishing of them, according to given patterns. The sequence and methods of performing these operations depend on the layout of the shell, the thickness of the metal, the equipment of the factories, and the techniques used.

The basic process -- bending billets with double curvature -- may be performed by the following methods: hot or cold stamping on presses; hot or cold rolling; pressure treatment with the aid of an explosion, the electrohydraulic effect, etc.

In foreign countries the method of cold stamping with gradual forming of lobes on 750 -- 3000 ton pressures (Fig. 7.32) is the most common method of producing billets for spherical tanks and gas holders up to 50,000 m³ in volume with a pressure of 2.5 - 6 - 18 kgs/cm².

In the USSR, until recently, lobes for cylindrical tank shells were made only by the method of hot stamping on presses of significant power with large punches and dies. In this method the billets are heated to 850°C before stamping. The edges are finished by hand or by automatic oxyacetylene cutting and the slag carefully removed. Inspection assembly of half the sphere is performed in the factory, during which time all connections are fitted and the shell is marked for assembly.

At the present time in the USSR, billets for spherical tanks of 600 and 2000 m³ capacity with a shell thickness of up to 16 mm are made by the cold rolling method proposed by G. S. Sabirov. Rolls are the principle equipment used in this technique. The axes of the two rows of rolls are arranged in circles, concentric to the curvature of the shell being manufactured. The rollers of the upper and lower rows are of a special shape which imparts the required curvature to the billet.

The lobe blanks are cut out with semi-automatic cutters along the entire length (from the bottom to the top of the shell). The sheets from which the lobe blank is cut are prewelded with an automatic welder. The blanks are cut out according to patterns. The outlines of the patterns are calculated so that after rolling the required dimensions of the lobes are provided without any additional finishing.

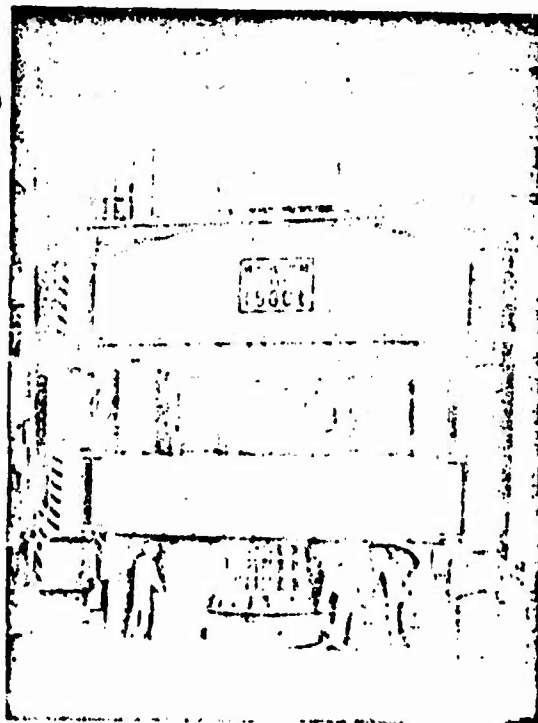

Reproduced from
best available copy.

Fig. 7.32. Stamping the lobes of spherical tank shells on a hydraulic press.

A spherical lobe is formed after one pass through the rolls. The rolls are equipped with racks and roll tables for stacking the flat blanks and receiving the rolled lobes.

The method of cold rolling spherical lobes is distinguished by a number of advantages.

1. It does not require complicated and expensive equipment.
2. The necessity of additional energy consumption for heating the billet (as in the case of hot stamping) disappears.
3. The productivity of the process of forming lobes is increased by several times.
4. The combination of precutting the edges according to a pattern with the rolling process provides for rigid tolerances in the dimensions and complete interchangeability of lobes.
5. Increasing the size of the lobes created conditions for reducing the labor and time required for assembling spherical tanks.

The manufacture of shells for droplet tanks differs in several features. The thickness of the metal of the shell is comparatively small (up to 8 mm). However, the lobes must have a curvature which varies in the meridional and equatorial planes.

Cold and hot stamping, stamping by explosion or the hydrodynamic effect may be used for making droplet tank lobes. It is possible to use the method of cold rolling on special rolls allowing for re-setting for rolling lobes of different curvature.

A simplified technique of making lobes was used for several droplet tanks of 2000 m³ capacity, constructed in the USSR. First, curvature in one direction was imparted to a billet of flat sheets on cylindrical rolls. Then each lobe was formed in the other plane of curvature on a special stamp with a punch tightened with screws.

The billets for the shells of high-pressure constant volume horizontal and vertical gas holders are made with the ordinary equipment of boiler factories. These structures are distinguished by their great wall thickness and comparatively small dimensions. The hemispherical end plates are made by hot stamping in powerful presses,

the die and punch having dimensions corresponding to the final dimensions of the end plates. The edge of the end plates is finished after stamping. This operation is performed on large turning lathes.

The edges of the cylindrical part are rolled on cylindrical rolls from rectangular billets. The manner of finishing the edges depends on the thickness of the metal and the welding technique.

Because of the great dimensions of this type of container (the diameter is 3.2 m) they are assembled and welded entirely at the factory. They are assembled with the aid of attachments with screw clamps. The edges are connected with tack welds. Welding is performed with automatic equipment under a flux layer. The gas holder is placed on a rolling stand, providing for its rotation at the required speed.

The metal structures of spherical and droplet tanks (supports, platforms, reinforcement, ladders) are made in factories as are ordinary metal structures.

The spherical endplates of gas holders of constant volume usually are made of two parts which are connected with tack welds. Then both parts at the same time are tack welded into a sphere and it is automatically welded, turning on a manipulator (with the exception of the joint between hemispheres).

Assembling High Pressure Tanks and Gas Holders

Spherical tanks and gas holders are assembled on a platform from individually placeable lobes by means of assembling and then welding.

In foreign practice, shells are assembled by the method of the step by step addition of individual lobes or large shell sections from the equatorial strip to the poles. Assembly is performed directly on the planned foundations. Assembly is performed manually in several layers from outside and inside.

In Soviet practice, completely automatic welding under a flux layer with rotation and manipulators is used for assembling spherical tanks of 600 and 2000 m³ capacity. This progressive solution was accompanied by the development of efficient means of assembly with the maximum (successively perfected) enlargement of assembly units, up to a hemisphere.

For spherical tanks and gas holders of 4000 m³ capacity and more, methods of completely mechanized welding in a protective gas medium or with powder wires are being developed.

We shall examine the two methods of assembling 600 m³ capacity spherical tanks most commonly used in the USSR: 1) from lobes made by hot stamping and 2) from lobes made by cold rolling. In the case of the first layout, 28 elements are used for the assembly (12 lobes in each band and 2 bottoms of 2 elements each). Such tanks are used as electrodehydrators with a calculated internal pressure of 7 kgs/cm². The thickness of the lobes of 09G2S steel is 24 mm.

Before raising, the lobes usually are welded into blocks (of 2 - 3 lobes each) on special hinged swinging stands (Fig. 7.33). Such stands make it possible to weld the seams automatically under a flux layer, the point of welding always being in a position close to horizontal. If the edges are finished from the outside of the shell, the lobes are stacked on the convex frame of the stand and vice versa. Reverse rewelding of seams is performed on the same stands with the appropriate frame.

Correct assembly of the lobes in a unit, for which a special rigid template is used, is very important.

Automatic welding and rewelding is performed in several layers.

The hinged swinging stand consists of three basic parts: an immobile lower frame with a boom swinging on the hinges of the upper (removable) frame, and a drive mechanism in the form of a winch with

a one-ton lifting capacity with an extra reduction gear. The winch raises or lowers one of the ends of the swinging frame in relation to the required position of the block for welding.

The blocks are assembled into hemispheres on a radial stand with the aid of a crane (see Fig. 7.34). A pedestal with an end plate welded to it is mounted in the center of the stand. The circumference of the diameter of the shell is marked out along the edge of the stand and fixed by welding supports. The blocks are supplied by crane and are installed with the wide part downwards on the supports, and the narrow, upper part -- on assembly plates welded to the bottom. The joints are assembled on wedge-shaped assembly attachments.

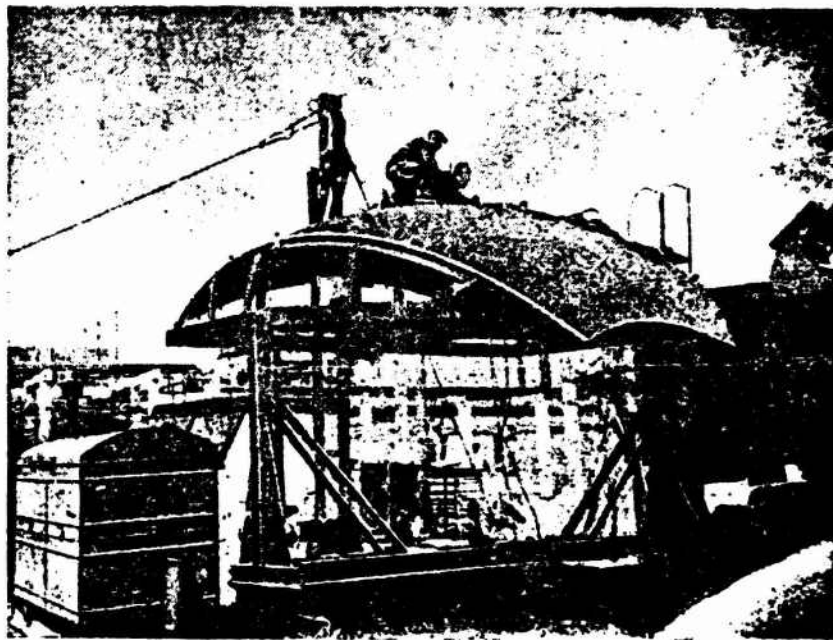

Fig. 7.33. Welding lobes into units on a hinged-swinging stand.

The correctness of the geometrical shape of a hemisphere is checked with a template and the circumference is measured along the equator. Variations in this dimension for the bottom and top hemispheres must not exceed 20 mm.

For the following automatic welding the seams on the radial stand must be rewelded manually. First the meridional and then the ring seams are welded.

The assembly of a shell is completed by overturning and setting the bottom hemisphere on the foundation or on a temporary support, and then by assembling and setting the upper hemisphere on it. Two SKG-30 cranes or two masts 30 m high each are used for lifting the hemispheres.

In order to facilitate installation of the hemispheres, sections of angle iron are welded to the upper one as guides, and one tier of staging is set up along the circumference of the stand for adjusting the assembly and manual rewelding of the seams.

Automatic welding of tanks is performed with a TS-17M tractor. When welding external seams it is placed at the zenith on top of the shell, and when welding internal seams -- inside downwards.

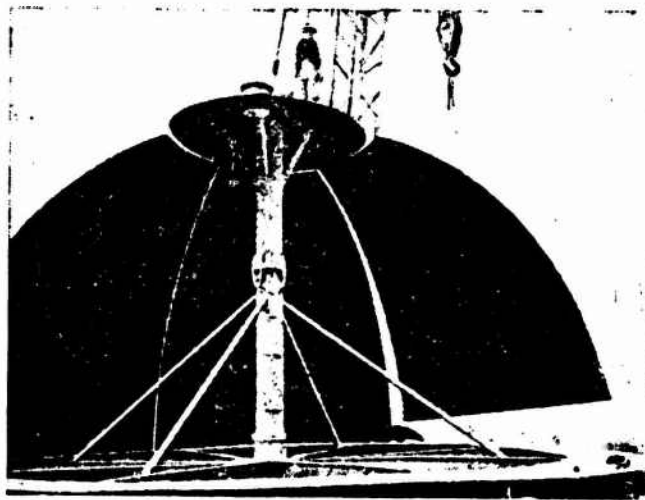

Fig. 7.34. Assembling a hemisphere from blocks on a radial stand.

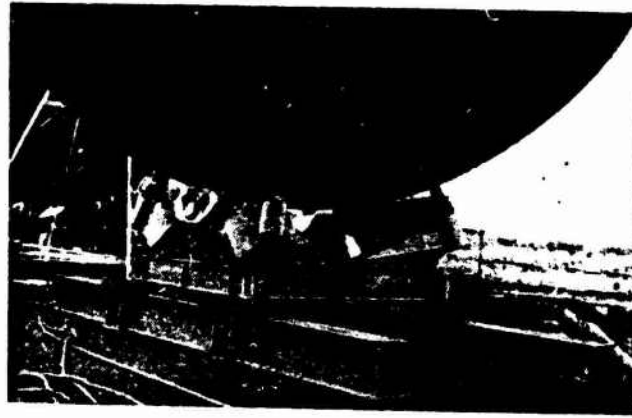

Fig. 7.35. Manipulator with steel rollers for rotating the shell of a 600 m³ capacity tank.

Welding is performed on manipulators (Fig. 7.35), providing for rotation of the entire shell at the required speed and in a given direction. The shell is set on the manipulator in a specific position so that the seam to be welded (meridional or equatorial) is in the vertical plane. The ring seams along the end plates are welded in several sections with their position at the zenith or in the bottom part of the shell (with welding from the outside or inside).

After welding, the spherical shell is set in the vertical position according to a plumb line attached inside and lowered onto the supports on the manipulator jacks.

In assembling spherical tank shells of large lobes made by cold rolling, the laboriousness and time-consumption of the operations are reduced significantly thanks to the reduction in the total number of lobes, their large diameter (from end plate to end plate), and also the interchangeability of lobes.

A shell consisting of 18 belt lobes is assembled on a temporary support ring fastened with brackets onto the mine planed tubular tank supports. First the lobes are grouped three to a block, being a sixth of the shell, on the ground. The blocks are welded manually on the inside. Then the blocks are installed on the support ring in the sequence indicated in Fig. 7.36. Ordinary assembly jigs or special

braces with a plate passing through the open space are used for assembling the blocks.

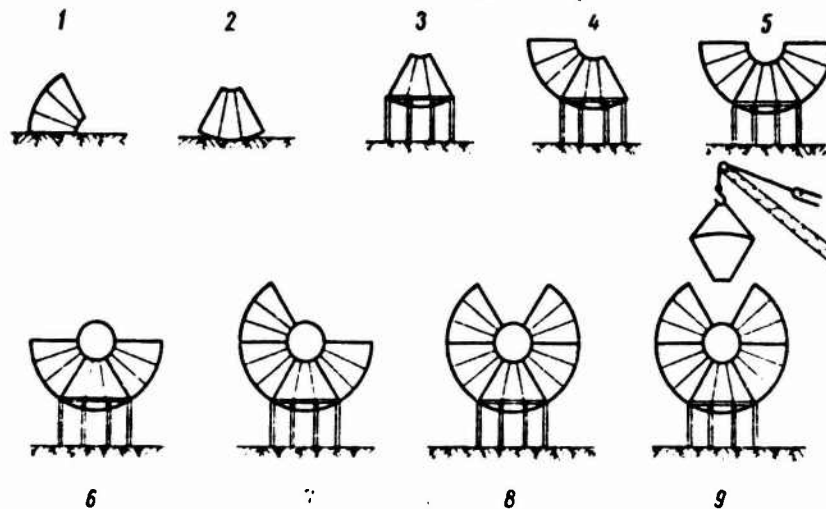

Fig. 7.36. Assembly of a spherical tank shell of lobes made by the cold rolling method.

The shell is raised on the rollers of the manipulator and is welded in approximately the same order as discussed above. While the welded shell is held on the manipulator jacks, the temporary brackets and support ring are removed, the shell is lowered on to the supports into the planned position. The vertical alignment of the axis of the shell passing through the centers of the end plates is aligned carefully.

The shell is fastened onto 8 aligned supports. The 9th support is removed temporarily so that the manipulator can be removed, and then it is replaced and attached to the shell.

A significant amount of experience in assembling 2000 m spherical tanks of 28 combined roll lobes and 2 end plates of 09G2S steel 16 mm thick has been accumulated. The diameter of such a shell is 16 m and the weight is 101.2 tons. The shell rests on 14 supports. Two methods are used for assembling such tanks. The first of them is the same as in the case of assembling a 600 m capacity tank shell of rolled lobes. The second method is based on setting up lobes with a vertical orientation.

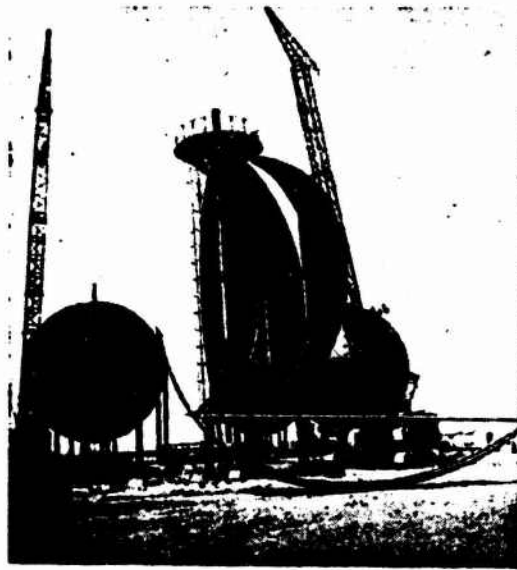

Fig. 7.37. Assembly of a 2000 m³ capacity spherical tank with the use of a support column.

At the beginning of assembly, the bottom end plate is fastened on a special support, and on it -- a tubular assembly column with the upper end plate. The column is unfastened with three wire braces and a rotating assembly cradle is attached to it. The first support column is installed on the foundation along the circumference.

The lobes are pre-grouped into 14 blocks in a special jig. In order to give a block rigidity during assembly, temporary pipe bracing is attached inside it. The first block is raised into the vertical position with an SKG-40 crane and attached to the end plates by means of assembly plates and wedges.

The following blocks are assembled in the same order, installing and temporarily attaching the next support column to the block (Fig. 7.37). Each block is attached to the end plates on assembly jigs, and one edge to the preceding lobe. The weight of the blocks is transmitted to the foundation through the temporarily attached column. The assembly plates are installed on a disc, previously welded along the edges of the lobes from the inside. A cradle, mounted in the middle of the column, is used for moving the workers while placing the fastenings. The cradle may be lifted near the inner surface of the shell in the vertical plane, and also rotated around the central

column, with the aid of winches.

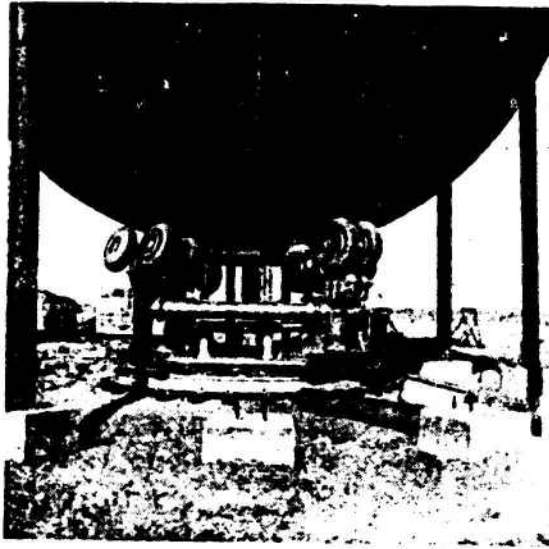

Fig. 7.38. All-Union Scientific Research Institute of Assembly and Special Construction Manipulator.

During assembly, the blocks also are connected with tack welds 100 mm long with a depth of penetration of 4 mm every 250 mm. The installation of the blocks is checked with templates. Then the blocks are welded with a hand backup weld, the reinforcing pipes, central assembly column, and assembly cradle are disassembled and removed. The manipulator is installed under the assembled shell in order to rotate it during welding.

An All-Union Scientific Research Institute of Assembly and Special Construction Manipulator (Fig. 7.38), in which the shell rests on 16 pneumatic tires of large diameter, is used for 2000 m³ capacity tanks. Half of these tires are drive wheels.

While the sphere, free of external columns, rests on the immobile support, the movable part of the manipulator is turned along a ring-shaped rail into the required position and raised to touch the shell with the aid of four hydraulic lifters. After this, the spherical shell is turned in the required plane for welding.

Welding is performed with a TS-17M tractor, placed at the zenith for welding the main external seam or in the lower part of the sphere for welding internal seams. The welded shell is installed in the planned position and is attached to the columns, after which the manipulator is dismantled.

The assembly of a spherical tanks ends with the installation of the metal columns, connections, ladder, and fencing, and also with the installation of the hatches, pipe fittings, and production equipment.

The assembly and welding of spherical tanks as containers operating under pressure is carried out in accordance with the rules of the State Committee of the Council of Ministers for supervision of industrial safety and for mining inspection.

A careful external inspection of all seams is performed from outside and inside and any defects observed (cracks, undercuts, splashes) are corrected. A certain part of the seams (not more than 10%) is subjected to gamma or X-raying, including all weld seam intersections. In some cases 100% ultrasonic inspection of seams is used.

Having installed and fastened the tank on its foundation and supports, hydraulic tests are performed. All hatches and pipe unions are covered or closed with plugs, and a pipe connection for letting out the air is installed in the top. Then the pipe connection is closed with a plug. The internal pressure is checked according to a manometer (it must be not more than 50% above the working pressure). After 5 minutes the test pressure is lowered to the working pressure. A careful inspection of the shell is performed, noting any defects. Defects are corrected after draining off the water. Then testing is repeated.

After the tank is tested and accepted, it is painted and, if provided for in the plan, heat insulation is applied.

The assembly of 2000 m³ capacity droplet tanks begins with laying the bottom sheets on a sand foundation. The foundation is compacted, wetting it with water, and then its cup-shaped form is checked according to a pattern. The upper layer of the foundation, 100 mm thick, is made watertight from a mixture of sand and asphalt. The bottom is assembled from pre-assembled welded pieces. Usually, an assembly column with a crane boom mounted in the center is used for assembling droplet tanks.

The column and boom are attached to the central part of the bottom, which is assembled first. The peripheral sections are installed with the aid of the crane boom. Manual or semi-automatic welding of the overlapping bottom joints is performed from one external side, which requires particularly careful observation of welding conditions. First the meridional seams of each ring in turn are welded, then this ring is welded to the preceding one.

A ring-shaped plate 1500 mm wide of previously cut sections of steel 10 mm thick is laid out for installing the support ring. The structures of the support ring, consisting of radial and annular ribs, braces, top and bottom angle bars of the support ring, are assembled on the plate.

The next stage of operations is the assembly of the two lower bands of the shell (from the bottom to the support ring) with the aid of a crane boom, and also welding them together. After this, 40 stiffening ribs are installed inside the tank. The ribs are welded to the shell with intermittent welds. The 20 supports of the shell are attached with bolts to each second rib. The tops of the supports are connected with bolts to the central ring on the assembly column.

Then, the remaining bands of the shell are assembled in sequence, from bottom to top (Fig. 7.39). Ring ties are installed at the level of each band.

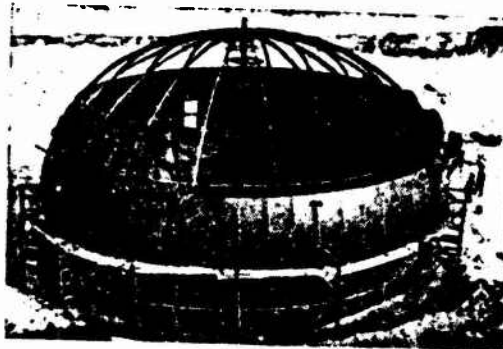

Fig. 7.39. Assembly of a droplet tank.

The fourth and fifth bands of the shell are assembled and welded from staging attached to temporary columns or brackets.

The sixth through ninth bands are assembled from an assembly cradle which rolls around the lower part of the assembled shell. The seams of the shell are welded from the staging and cradle from the outside and the density of the seams is monitored.

Seams may be welded from the inside from moveable staging or from a raft which floats up as the tank is filled with water.

The ladder and the railing around the circular platform are assembled. A skylight and pipe connections for equipment are cut into the top end plate. The decking of the circular platform is assembled here.

Droplet tanks are tested by filling them with water. Excess pressure and rarification are created when a closed tank is filled or drained. If the working pressure is 4000 mm of water and a vacuum is 300 mm of water, tests are performed with these values exceeded somewhat.

Both ordinary droplet, and multi-torr tanks, designed for pressure of 1.4 -- 2.1 kg/cm², are constructed abroad. The capacity of such tanks reaches 25,000 m³. Revolving derricks and masts in the center of the tank, and also powerful cranes moving outside the tank are used in assembling them.

Cylindrical, horizontal and vertical gas holders of constant volume, and designed for high internal pressure, arrived at the construction site ready in one piece or in large pieces. They are transported by railroad.

If necessary, final assembly and welding of the ring assembly joint between parts of the gas holder are performed at an assembly area.

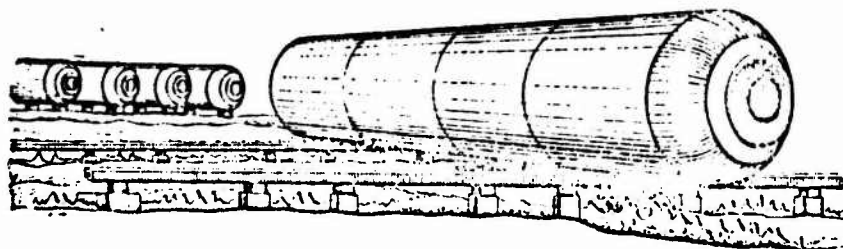

Fig. 7.40. Installation of high pressure horizontal gas holders.

These operations are performed on racks. The structure is rotated during welding on roller stands or by rolling along beams (Fig. 7.40). A gas holder, depending on its dimensions and weight, may be laid on its supports by one or two pipe layers.

Vertical gas holders are installed on their foundations by one of the methods used in assembling vertical equipment with the aid of cranes, assembly masts, gantrys or derricks. Also it is possible to use previously installed gas holders for attaching the upper pulley of a block and tackle to them.

Chapter Eight

CONSTRUCTING UNDERGROUND STORAGE AREAS FOR OIL PRODUCTS AND LIQUEFIED GASES

The entire range of underground storage areas may be classified in the following way:

storage areas constructed in rock salt deposits by washing away the salt through bore holes;

storage areas constructed in hard, dense rock by the shaft method;

storage areas constructed in ever-frozen rock deposits;

storage areas created by the adaptation of natural caves and artificial excavations;

storage areas created in porous structures, emptied gas and oil deposits;

tanks constructed by special methods.

The greatest number of underground tanks are constructed for storing liquefied hydrocarbon gases. They are also constructed for oil products and crude oil.

§1. Underground Storage Areas in Rock Salt Deposits

Underground storage areas created in rock salt deposits have been used very extensively.

Deposits of Rock Salt and Its Properties

Underground tanks may be created in rock salt deposits of all five morphological types: bed, bed-lens, pocket, dome, and stock deposits. Salt deposits occur at different depths from the earth's surface. In some places, salt domes emerge onto the surface. Thus, in Central Asia the Khodzha-Mumyn salt dome rises to 900 m above the surrounding surface, and the Khodzha-Sartis dome -- to 700 m. In other regions, rock salt deposits are deep. In practice, salt beds

occurring at a depth of up to 1200 m are used for underground storage areas. The thickness of salt beds varies greatly, from several meters to a kilometer, and individual domes measure several kilometers from the top to the base.

Salt beds less than 20 - 30 m thick are not used for creating underground tanks by washing. The washing methods developed in the USSR make it possible to build underground storage areas in beds with a minimum thickness of 4 - 5 m.

Beds and domes are composed either of almost pure salt -- the mineral halite, the content of which reaches 99.6%, or contain scattered inclusions, layers and lens of anhydrites, hydromicas, gypsum, polyhalites, carbonates of calcium and other minerals. The chemical composition of halite is 39.39% Na and 60.61% Cl. Its molecular weight is 58.44, the specific gravity is 2.1 -- 2.2 and the hardness according to the Mohs scale is 2.0 -- 2.5.

The physicommechanical properties of the rock salt of different deposits differ greatly. Ordinary salt is characterized by a tensile strength of 250 -- 300 kg/cm², while the strength of the salt of certain deposits reaches 600 kg/cm². The compressive strength of rock salt is higher in the case of horizontal bedding. In the case of inclined bedding, the compressive strength decreases significantly. The mechanical properties of salt change (its hardness decreases) in the case of contamination with clay and other impurities. The hardness of rock salt also is reduced in the case where it has been subjected to tectonic disturbances.

The transverse strength of rock salt is 25 -- 40 kg/cm . According to P. N. Chervinskiy's data, the compressive σ_{com} , transverse σ_{tr} and tensile σ_{ten} strengths of rock salt are interrelated as 1: 10: 51.

The tensile strength of rock salt varies from 2 to 10% of the compressive strength. Its lowest value refers to salt, the layers of

which are arranged perpendicular to the loads acting on it.

Salt is transformed from a brittle state into a plastic state at a pressure of 150 -- 275 kg/cm². It is especially plastic when it is wetted or immersed in water. In hot water, a salt crystal may be bent with the fingers. Upon being wetted with water, capillary cracks in crystals close and the tensile strength increases significantly. The plasticity depends on time. For quite a long time rock salt is capable of flowing even with a low external pressure. Because of its high plasticity, salt does not retain cracks. However, these qualities of rock salt deteriorate in the presence of seams and scattered inclusions.

Principles of Tank Construction and the Choice of Areas for Construction

Underground tanks in rock salt deposits are constructed by means of washing out (leaching out) cavities in a salt bed through bore holes. Rock salt is washed away by two fundamentally different methods:

1) by pumping fresh water along one pipe column and forcing brine to the surface along another -- the circulation method (Fig. 8.1);

2) with jets of water sprayed in the tank at atmospheric or high pressure by a special irrigator -- the jet method or the irrigation method (Fig. 8.2). The brine is pumped from a sump pit in the chamber being washed out by a submersible pump or is forced out by compressed air.

As is shown in Fig. 8.1, the bore hole for circulation washing is equipped with three pipe columns. The washing water is pumped into the bore hole along the water feed pipe column. Dissolving the rock salt, it turns into brine, thus increasing its density, and the brine descends into the bottom part of the chamber. The new portion of "fresh" water float up on top of the chamber. By increasing the water pressure at the well head, the brine is forced to the surface along the brine raising pipe column.

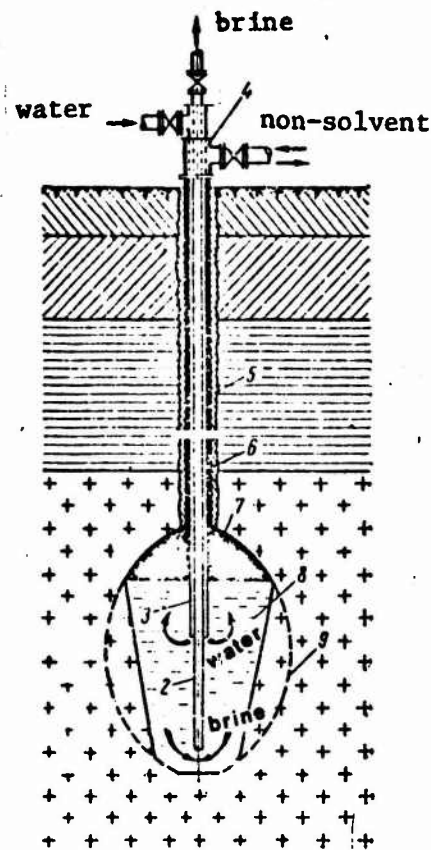

Fig. 8.1. Washing out an underground tank in a bed of rock salt by circulation method. 1 - rock salt bed; 2 - brine intake (working) pipe column; 3 - water intake (working) pipe column; 4 - well head; 5 - cementing of space around pipe; 6 - casing pipe column; 7 - non-solvent; 8 - chamber to be washed out; 9 - planned outline of tank.

The upper part of the underground chamber washed out to the planned dimensions is artificially sealed from further dissolving (preserved) by means of lowering the level of the non-solvent introduced along the casing pipe column.

A liquid lighter than water or gas, not entering into chemical combination with rock salt, brine or water, is called a non-solvent. Usually oil products, for the storage of which a tank is washed out, or air are used as the non-solvent.

Rock salt easily dissolves in fresh water. In one m^3 of water at 20°C up to 358 kg of salt may be dissolved. Six - 7 m^3 of water

is required for obtaining a concentrated brine for the formation of a 1 m^3 tank, and the amount of water is increased if weak brines are to be obtained.

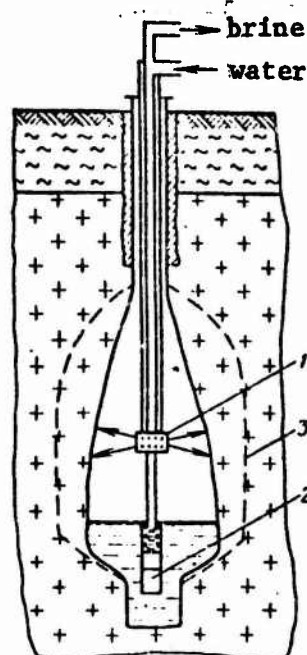

Fig. 8.2. Washing out an underground tank in rock salt by the jet method. 1 - irrigator with nozzles; 2 - submerged electric pump for pumping out brine; 3 - planned outline of tank.

The underground tank is used the same way as it was washed out, through the bore hole. When being used, the water supply column is removed from the bore hole. The product is pumped in and removed along the casing column.

The removal of the product from an underground tank is performed by replacing it (forcing it out) with brine, which is supplied along a brine column inside the chamber under the product from a special brine storage area, and during filling, on the other hand, the brine is replaced with the product. For storing brine on the surface it is necessary to have a brine storage tank equal in volume to all underground tanks in the storage area or, in individual cases, equal in volume to one very large underground tank.

The minimum depth for the location of underground tanks for liquefied gas is determined starting from the physical properties of the gas, its vapor pressure and the specific geological conditions.

Thus, for liquefied butane, tanks must be no less than 40 - 60 m deep, and for liquefied propane -- 80 - 100 m. In this case it is considered that 1 kg/cm² of working pressure in a tank is balanced by the pressure of a rock layer no less than 6 m thick above the tank.

Location of Underground Tanks

The distance between individual tanks in an area is determined in relation to the maximum tank diameter, the probable bending of the bore hole, the minimum permissible size of the interchamber pillar, the potential distortion of the shape of the tank while being washed out, and the errors in monitoring it.

The distances between the mouths of bore holes being used are determined according to the formula

$$l = 0.07H_d + R(m+n+k), \quad (8.1)$$

where 0.07 is a coefficient considering the probable bending of the bore hole during drilling; H_d is the drilling depth in m; R is the radius of the underground tank in m; m is a coefficient considering the minimum size of the interchamber pillar in relation to tank shape; n is a coefficient considering the error in controlling the process of tank formation; k is a coefficient considering the distance from the tank walls of the bore hole axis and the possible asymmetry of the shape of the tank formed by leaching.

The value of the coefficient m is taken as equal to the corresponding values for tanks:

- Of spherical shape 3
- In the form of bodies of revolution,
extended along the bore hole axis 4

The value of the coefficient n is taken as equal to the following values for leaching according to the following methods:

- From top downward 0.1
- From the bottom upwards 0.5
- Combined 0.2

The value of the coefficient k is determined according to the data in Table 8.1.

Table 8.1

Type of deposit	Value of k for leaching		
	From top downward	From bottom upward	Combined
Bed	2.2	2.7	2.4
Bed and lens	2.2	2.7	2.4
Dome and stock	2.5	3.5	3.0

When positioning underground tanks in an area the possibility of washing them out in thick salt deposits at different depths in different strata is considered. In such an arrangement of tanks, the distance between the mouths of the bore holes may be reduced, but the minimum distance from a tank wall to the neighboring bore hole must not be less than 30 m.

The size of the pillar with respect to the least distance between adjacent tanks is calculated according to formula (8.1).

Drilling and Testing Bore Holes in Use

Bore holes for washing out underground tanks and using them are drilled by the usual methods with the equipment used for drilling oil and gas wells.

Pipes 194 - 325 mm in diameter are used for casing the wells. The diameter of the pipes of the casing column, which when the tank is used becomes a pipeline for the pumping in and removal of the product, is determined from the condition of providing the necessary capacity for delivering and retrieving the product and equality of the hydraulic resistances of the movement of brine along the central working column and the product along the casing.

The columns for supplying water and removing brine are chosen according to the principle of equality of hydraulic resistances. In drilling, especially in salt, often it is observed that bore holes stray from the vertical because of increased slipping of the drilling tool. Bending of bore holes complicates the process of lowering and raising the working columns, and complicates or makes impossible lowering geophysical instruments, samplers, well callipers and sonar equipment into the bore hole. The bending of bore holes in the washing area may cause the formation of an asymmetrical tank, which reduces the stability of the underground chamber. Very significant bending of bore holes may lead to a reduction in the calculated dimensions of pillars and chamber connectors. Therefore, bore hole deviations from a given direction must not go beyond the limits of a cone, the generatrix of which makes a 2% angle with the vertical passing through the mouth of the bore hole.

The casing pipe column must provide reliable insulation of the covering rock over the underground tank, and sealing of the bore hole. A column is sealed by good packing of the joints with the aid of sealing oils, welding the columns or welding couplings.

The entire length of a bore hole is cemented up. As practice shows, the speed of the ascending flow must be no less than 1.5 m/s for high quality cementing. The cement hardening time is no less than 48 hours.

The quality of the cementing and the height of raising the cement solution is determined by thermal well logging.

At the end of the cement hardening time, the casing pipe column is tested for sealing. Testing is performed with brine. The test pressure p_t at the head is determined according to the formula

$$p_t = 1.25 \{0.1H (\rho_p - \rho_b) + \Delta h\}, \quad (8.2)$$

where 1.25 is a coefficient considering the increase in test pressure; 0.1 is a conversion factor from ts/m^2 into kgs/cm^2 ; H is the height

of the column of liquid in m; ρ_b is the brine density in t/m^3 ; ρ_p is the density of the stored product in t/m^3 ; Δh is the sum of the hydraulic resistances in the bore hole in kg/cm^2 .

During testing, the pressure at the head must not exceed a value determined by the formula

$$P_{max} = 0.1L(k\gamma - \gamma_t), \quad (8.3)$$

where p_{max} is the maximum permissible pressure at the well head in kg/cm^2 ; L is the depth of lowering the casing column in m; k is a safety factor taking account of the phenomenon of hydraulic rupture, $k = 0.9$; γ is the mean volume weight of the covering rock in t/m^3 ; ρ_t is the density of the test liquid in t/m^3 .

A column is considered to have passed the test if in the course of 30 minutes the pressure drop does not exceed 2% of the test pressure, the pressure drop being considered after raising it three times to test pressure without intermediate unloading. The bore hole is sunk to the depth of the future tank along the working layer of salt after the casing pipe column is cemented. Then according to the rule presented above, the bore hole is tested again.

After testing, the bore hole is flushed with brine, and then the working pipe columns are lowered into it. Since the product to be stored will be fed into the tank and removed from it along the casing column, after lowering the working columns the casing column and the reliability of the cementing of the space around the pipe are tested with the oil product to be stored under maximum and working pressure.

Means of Constructing Underground Tanks by the Washing Method

Underground storage chambers are major structures designed for long-term use. Therefore, they must have dimensions and a shape providing for stability in conditions of rock pressure. The high demands for stability of underground tanks are dictated also by safety considerations, since if the chambers rupture it is possible that gas or oil will escape to the surface.

Underground chambers having a shape close to spherical and in the form of an ellipsoid of revolution are the most stable. The creation of chambers of the given configuration in rock salt deposits is possible only by means of controlled leaching with monitoring of the volume and shape of the chambers.

Washing out rock salt through bore holes for the purpose of extracting sodium chloride brines was begun in Russia in 1909. The possibility of mining rock salt beds at a great depth, the small amount of preparatory operations required and the great economy led to the development of this method. At first underground leaching was performed by the direct flow and counterflow methods (Fig. 8.3) with the aid of a two-pipe system: a casing pipe column and a central working column.

Direct flow leaching is a mode of leaching out a chamber in which the level of introducing water into the chamber is located below the level of removing the brine. Counterflow leaching is a mode of leaching out a chamber in which the level of introducing the water into the chamber is located above the level of removing the brine.

In washing out rock salt by the counterflow method, the shoe of the working column is installed at the well bottom; water is supplied along the casing pipe, and the brine is removed along the working column, as is shown in the left part of Fig. 8.3. The rock salt is dissolved in a chamber filled with liquid. With such a method of leaching, a chamber is formed in the shape of a cone with the vertex turned downwards, and with a highly developed sealing, which depends on the brine distribution according to the degree of saturation of the water with salt. New quantities of water, supplied along the casing pipe, up the uncased bore hole, cause intensive dissolving of the sealing area; the brine obtained sinks below. This area is washed out with weak brine and therefore dissolving takes place less intensively here. The more saturated brine sinks below and the washing out here is even less intensive. At the bottom, the brine is highly concentrated or even a saturated brine with a relative density of 1.2.

Practically no washing out takes place here. The continuous supply of new amounts of water into the chamber makes it possible to force the brine along the central pipe to the surface.

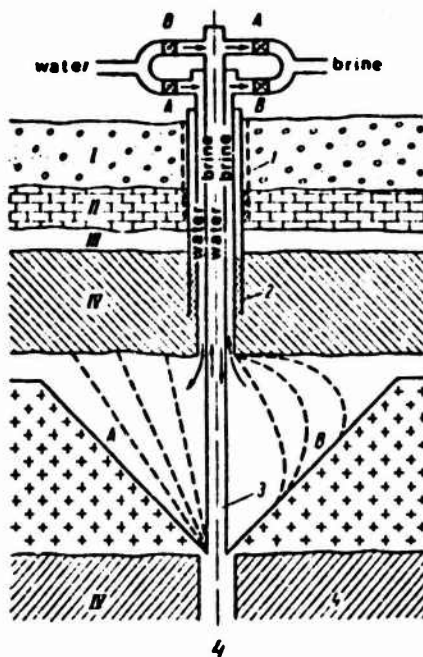

Fig. 8.3. Washing out rock salt with a counterflow and a direct flow. I - gravel; II - limestone; III - water stratum; IV - slate. 1 - 200 mm conductor; 2 - 150 mm casing pipe; 3 - 90 mm pipe; 4 - 150 mm bore hole.

As dissolving continues, the lateral surface of the cone becomes more gently sloping and is covered with different impurities found in the rock salt. The dissolving process slows down and dissolving along the roof of the chamber takes place approximately at a constant rate equal to the linear rate of dissolving a vertical surface of rock salt in fresh water (10 - 12 cm/day). Therefore, the height of the dissolved top part will be very insignificant. After a year, the diameter of the base of the cone may reach 75 - 90 m.

Thus, in case of washing out with the counterflow method, the rock of the roof of the salt bed is exposed over a large area. This causes fracturing of the rock under the action of the rock pressure and, as a consequence, rupture of pipes, collapse of the lower part of the chamber and, finally, makes the bore hole unserviceable.

With the direct flow method of washing out, the water is supplied along a central pipe, as is shown in the right part of Fig. 8.3, and

the brine is forced out through the casing pipe.

In the initial moments of washing, a pear-shaped chamber is formed, and then the tank acquires the form of a counterflow chamber with a highly developed ceiling. The formation of a chamber of this form is explained by the fact that, in the initial moment, the "new" water fed downwards dissolves the adjacent area, and therefore the most washed out part forms downwards. The water, becoming saturated with salt, loses dissolving activity as it moves, and therefore the upper part of the chamber is washed out only slightly.

At first the saturated brine does not flow down the chamber because of the significant speeds of the ascending flow. When the dimensions of the chamber increase, the speed of the liquid in it decreases and the heavier brine is not drawn to the top of the chamber. Thus, two counterflows appear. In the peripheral part of the chamber, the water becomes more and more saturated with salt and sinks down. The preferential dissolving of the lower part of the chamber ceases. Experience in washing out underground chambers shows that this period begins with a chamber diameter of 9 m. However, this depends on the height of the chamber, the rate of washing and the position of the working column. There comes a moment when new amounts of "fresh" water float up before reaching remote points at the bottom. More intensive washing of the top part begins and first a cylindrical, then finally a cone-shaped chamber with a greatly washed out ceiling is formed, which also occurs in the case of counterflow washing.

The advantage of both methods is the simplicity and the small consumption of metal, since only a two-column system of pipes is used. Elements of these methods are found in all improved systems used for washing out chambers.

The further development of the underground method of leaching out rock salt proceeded along the path of creating controlled methods of washing.

The dissolving of rock salt in water is a heterogeneous process, proceeding in the diffusion area.

Almost at the same time Shchukarev (1896), Noyes and Whitney (1897) gave the following general equation for the kinetics of dissolving:

$$\frac{VdC}{dt} = kS(C_s - C), \quad (8.4)$$

where V is the volume of the solution; C is the concentration of the solution at a moment of time; C_s is the concentration of saturated solution; S is the dissolving surface; k is the coefficient of the dissolving rate.

For determining the linear dissolving rate W it is possible to use Noyes and Whitney's relationship

$$W = \frac{q}{\rho_s} = \frac{k(C_s - C_0)}{\rho_s}, \quad (8.5)$$

where q is the amount of salt going into solution from a unit of surface in a unit of time; k is the dissolving coefficient; C_s is the saturation concentration; C_0 is the solvent concentration at a distance from the surface; ρ_s is the density of rock salt.

From equation (8.5) it follows that the smaller the solvent concentration, the greater the dissolving rate.

The investigations of Kulle and Korolev (1949) showed that the dissolving coefficient and dissolving rate vary within wide limits depending on the angle of inclination φ of the dissolving surface to the horizon. For example, where $\varphi = 0$ $q \approx 3.5 \text{ kg/m}^2 \cdot \text{h}$, where $\varphi = 90^\circ$ $q \approx 10 \text{ kg/m}^2 \cdot \text{h}$, where $\varphi = 180^\circ$ $q \approx 24 \text{ kg/m}^2 \cdot \text{h}$. These values of q are valid for $C_0 \rightarrow 0$ and a temperature of $t = 15^\circ \text{ C}$.

Consequently, a horizontal surface, or the roof of a chamber, will have the greatest dissolving rate. The dissolving rate of a vertical surface (chamber wall) is approximately two times less than the maximum rate. The bottom of a chamber dissolves at a minimum rate, which practically approaches zero, since during the dissolving process insoluble impurities, hindering the penetration of the solvent to the salt, fall onto this surface.

According to Nernst, the dissolving coefficient is

$$k = D/\delta, \quad (8.6)$$

where D is the diffusion coefficient, δ is the thickness of the layer of saturated solution on the dissolving surface.

P. A. Kulle obtained empirical relationships for determining the rock salt removal (dissolving rate) W in the case of the inclination of the dissolving surfaces at different angles to the horizon.

The salt removal in the case of the dissolving of surfaces inclined to the horizon at angles of from 0 to 90° , is determined according to the equation

$$W = \left(1 - \frac{C_a \rho_{sb}}{C_s \rho_0}\right) \left(1 + \frac{t}{22.4}\right) (3.25 \varphi^{0.6} + 1.8), \quad (8.7)$$

For surfaces inclined to the horizon at angles of from 90 to 180° , it is necessary to use the formula

$$W = \left(1 - \frac{C_a \rho_{sb}}{C_s \rho_0}\right) \left(1 + \frac{t}{22.4}\right) (8.75 \sin \beta + 5.87), \quad (8.8)$$

where ρ_{sb} is the saturated brine density; ρ_0 is the solvent density;

β is the angle of inclination of the surface; 3.25; 1.8; 5.87; and 8.75 are dimensional coefficients.

The dissolving rate of rock salt increases with an increase in the water temperature. For a vertical surface

$$q = 5.87 \left(1 + \frac{t}{2.24} \right) \quad (8.9)$$

Underground tanks are leached out in conditions of forced convection with a changing solvent concentration. Therefore the rock salt dissolving rate and other washing parameters, determined by calculation, will have some discrepancies as compared with the real values.

The formulas which are used currently for calculating the process of leaching out underground chambers are obtained by means of assumptions simplifying the dissolving process, and are extended to chambers of relatively simple geometrical form.

The dissolving of rock salt is accompanied by the electrostrictive effect, as a result of which the volume of the brine obtained will be less than the total volume of the rock salt and water. This factor is considered when calculating the volume of leached out chambers and testing them for sealing.

As a result of experimental investigations, A. G. Pozdnyakov succeeded in refining P. A. Kulle's formula for determining brine concentration; in the case of washing with fresh water

$$C = C_s \left(1 - e^{-\frac{\sum_{i=1}^n \bar{k}_i S_i t}{Q}} \right); \quad (8.10)$$

in the case of washing with brine with a concentration

C_0

$$C = C_s \left(1 - e^{-\frac{\sum_{i=1}^n \bar{k}_i S_i t}{Q}} \right) + C_0 e^{-\frac{\sum_{i=1}^n \bar{k}_i S_i t}{Q}}, \quad (8.11)$$

where Q is the rate of removing brine from the chamber in m^3/h ; n is the number of spatially differently oriented elements of the active surface.

The time T required for washing out an underground tank is calculated according to the formula

$$T = \frac{V_c \gamma_c}{S_{l.av} W_{av}}, \quad (8.12)$$

where V_c is the volume of the chamber to be washed out in m^3 ; $S_{l.av}$ is the lateral dissolving surface in m^2 , averaged for the entire washing period; W_{av} is the average rate of salt removal from a unit of lateral surface.

Special washing methods have been developed for constructing underground tanks in rock salt deposits. The most widely used is the combined method (Fig. 8.4), including elements of the method of a gradual counter-flow from top to bottom.

Washing by the combined method is subdivided into two stages. In the first stage a cavity is formed in the ascending direction. First a hydraulic cut is washed out (first stage of washing), and then there are several more stages before obtaining a chamber of the predetermined dimensions. In the second stage the upper and lower parts of the chamber are formed towards one another: the upper in the descending direction, and the lower in the ascending direction. Leaching proceeds from the top downwards in order to impart a given shape to the block of untouched rock salt (third and fourth stages).

Upon the transition from the second stage to the third, that is, upon the transition from washing from the bottom upwards to washing from the top downwards, the level of non-solvent rises to the roof of the future tank and changes the level of feeding water into the chamber. Further leaching is performed with a constant position of the water feeding column with periodic pumping

of non-solvent according to a procedure providing for the formation of the upper part of the chamber in counter-flow conditions.

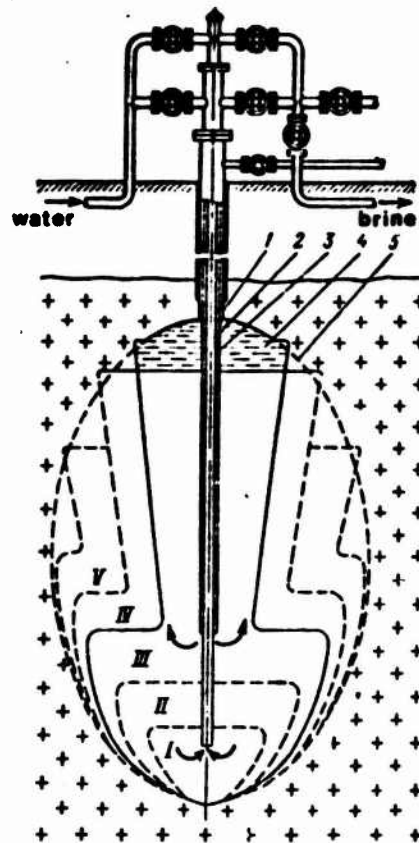

Fig. 8.4. Combined method of washing.

1 - Casing pipe column; water feeding working column; 3 - brine raising working column; 4 - non-solvent; 5 - outline of planned tank; 1-V - washing stages.

Contiguous counter-flow is specified as the basic method for leaching according to the top down scheme. A leaching regime, in which the distance between the level of introducing water and removing brine in the chamber is less than half the distance between the level of the non-solvent and the level of removing brine is called contiguous counter-flow.

Continuous counter-flow provides for a more uniform

development of the chamber with respect to height, which makes it possible to form the roof of the tank with the aid of the non-solvent without resetting the working columns. The brine raising column must be lowered to the very bottom of the chamber, but it must not become clogged up with settled particles of insoluble rock.

The order of washing used in the combined method makes it possible to combine reliable control of tank formation with high washing intensity under favorable conditions for picking up insoluble inclusions, which makes the method reliable for creating chambers of spherical and spheroidal form in different rock-geological conditions.

In individual cases, especially in the case of comparatively thin salt beds, it is expedient to create large underground storage areas by means of joining two bore-holes and by direct washing. Bore holes may be joined by connecting two hydraulic cuts or by directed drilling.

After joining bore holes the salt pillar between them is washed out. The top of the connected cavities is formed according to the top to bottom method.

In the case of washing out a cavity from top to bottom and in the case of the combined method the basic condition is obtaining a vaulted ceiling, which in comparison with a flat ceiling makes it possible to increase the stability of the tank significantly and to increase the maximum radius of the underground tank.

In order to control the washing process it is necessary to determine the regularity of supplying the non-solvent and the regularity of washing out the salt in a given outline.

The non-solvent pumping capacity q_n as a function of time is determined according to the equation

$$q_n = \frac{dQ_n}{dt}, \quad (8.13)$$

where dQ_n is a unit volume of a chamber, filled after the time dt .

The value of q_n is calculated for ceilings of different configuration. Thus, for example, for a spherical shape

$$q_n = \frac{\pi r_c^2 v_{s,h} \tan \psi}{R_r h_n \tan \psi + r_c}, \quad (8.14)*$$

where r_c is the chamber radius at the point of contact of the non-solvent and brine in m; $v_{s,h}$ is the horizontal salt dissolving rate in m/h; R_r is the roof radius in m; h_n is the height of the non-solvent layer in m; ψ is the angle of inclination of the dissolving surface.

A graph of the pumping capacity, according to which the pumps or a group of pumps are chosen, is compiled for the non-solvent pumping during the formation of the chamber roof. Pump operation, as the entire washing process, may be completely automated.

Washing Out Tanks With the Use of a Gaseous Non-Solvent

The leaching process is controlled with the aid of a liquid or gaseous non-solvent. The simplest and cheapest non-solvent is air since it need not be transported and stored, and the washing process becomes fire and explosion proof. Subsequent flushing of the finished tank is not required with the use of air.

Air as a non-solvent may be introduced into the leaching chamber by pumping with a compressor directly into the space around the pipes between the casing and water feeding columns or by means of supplying it together with water along the water supply column. Considering the great depth of underground tanks, high pressure compressors are necessary for pumping air along the casing column. Thus, with an underground tank placed at a depth of 1000 m,

* V. A. Groskhotov's formula.

considering that the system may be filled with brine, the compressor must develop a pressure of not less than 120 kg/cm^2 . This requires complicated equipment and is not justified economically.

Pumping air together with water into the washing chamber is more profitable. The air separates out in the chamber and collects in its upper part, creating an air cushion which protects the ceiling from arbitrary washing.

Methods of feeding air into the water line are shown in Fig. 8.5.

The introduction of air into the pressure line from a pump to a well (Fig. 8.5a) requires the installation of a compressor of quite high pressure, which reduces the efficiency of the method.

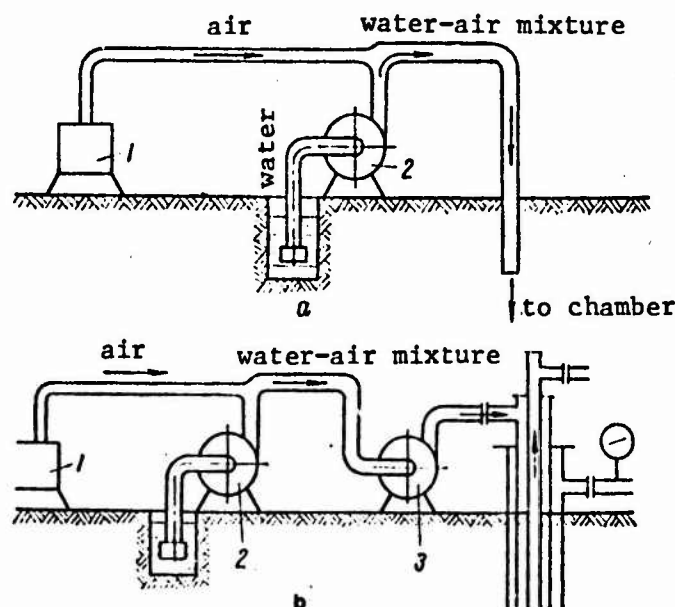

Fig. 8.5. Methods of feeding air into an underground chamber.

a - into a pressure line; b - into an intermediate line.
1 - compressor; 2 - low pressure pump; 3 - medium pressure pump.

A method using two centrifugal pumps (low and medium pressure) connected in series with the air intake after the first low pressure pump (Fig. 8.5, b) and also a method of feeding air through special

openings in the housing of a multi-stage pump and mixing with water after the first (or second) impeller, are the most efficient. These methods also use low or medium pressure compressors, but the pumps fulfill the role of pressure compressors.

The pressure and the solubility of air in water in the air mixture increase as it moves down along the bore hole. Each cubic meter of water carries a specific amount of air with it, equal to the specific capacity, that is, the air feed per 1 m³ of water — q_a . Then in the underground chamber, as a result of the sharp reduction in the speed of the mixture, from each 1 m³ of water there is released a certain volume of air

$$V_a = q_a - S_w \quad (8.15)$$

where S_w is the solubility of air in water at the temperature and pressure at the outlet from the water supply column.

In addition, the air saturated water, entering the chamber, mixes with brine. The solubility of air and brine is less than in water, and therefore decreases with an increase in brine concentration. Consequently, with the conversion of water into brine an additional amount of air, determined by the difference of the solubility of air in water S_w and in brine S_b at a given concentration, pressure and temperature, will be released from each cubic meter of brine.

The air bubbles, as a consequence of their low density in comparison with brine, will rise upwards and accumulate along the salt ceiling being washed out, preventing further washing. The amount of air released from solution per day is

$$q = 24Q_a(q_a - S_a) + 24Q_p(S_w - S_b) \quad (8.16)*$$

*B. N. Fedorov. The formation of underground tanks, leached out in rock salt deposits with the use of a gaseous non-solvent "Gazovaya Promyshlennost'", Moscow, Central Scientific Technical Institute of the Gas Industry, 1967, No. 2.

where Q_w is the output with respect to water in m^3 ; Q_b is the output with respect to brine in m^3 ; S_b is the solubility of air in brine in m^3/m^3 .

In order to determine the volume which the air released may occupy it is necessary to determine the air pressure p on the brine-air interface

$$p = (L+h)\rho_{mix} + p_a. \quad (8.17)$$

where L is the depth of the air-brine contact in m ; h is the head loss in the brine raising column in m of water; ρ_{mix} is the mean value of the density of the brine-air mixture according to the height of the brine-raising in t/m^3 ; p_a is the atmospheric pressure in kg/cm^2 .

The pressure of the water-air mixture at the wellhead and the required amount of air for pumping into the cavity being washed out are determined for a complex solution of the problem of washing with an air non-solvent.

The very small air bubbles which arise during the continuous degassing of the brine, rising up in large amounts, perform an additional macrotransport of the dissolving substance. In this case there is observed a more intensive dissolving of the sidewalls of the chamber and a certain retardation of the dissolving of horizontal surfaces, which has a favorable effect of the formation of tanks.

The Water-Jet Method of Washing Out Underground Tanks.

By the very nature of the physicochemical processes involved, the dissolving of salt by circulation leaching takes place comparatively slowly. Attempts to intensify the washing process by means of using ultrasound, raising the temperature of the water pump into the bore hole, and other approaches have not had success.

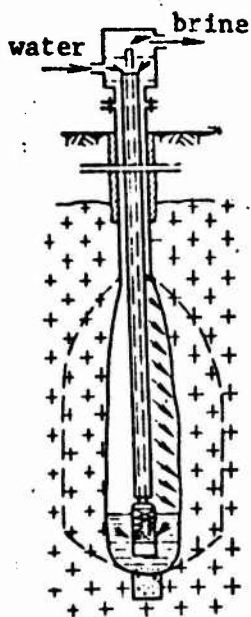

Fig. 8.6. Washing out a tank by the water-jet method.

The conditions of dissolving rock salt change fundamentally if the water is supplied in the form of a jet directly onto the salt surface with the aid of a directing apparatus. The water is supplied from the directing apparatus onto the salt surface at atmospheric pressure in the chamber, in a compressed air medium or in the form of submerged jets (under the water level). In all these cases there is direct interaction of the water with the salt and there is an additional hydrodynamic factor which promotes intensive dissolving of the latter.

Figs. 8.2 and 8.6 show diagrams of the creation of underground tanks by the water-jet method. The bore hole has a casing pipe column and two working type columns, a water supply pipe column ending in a system of nozzles and a brine collecting column inside the water supply column.

In Fig. 8.6 it is shown that the nozzles on the water supply column are arranged along the entire height of the future tank. In this case washing proceeds uniformly with the rotation of the pipe column with the nozzles. Given the diameter of the nozzles and the pressure it is possible to obtain a trajectory and jet length which provide for washing out tanks of a given form (with a dome-shaped ceiling) and dimensions. The water, striking the salt walls, destroys and dissolves them, flows downward and is converted into brine. The brine may be collected with submerged pumps, jets or by compressed air if the necessary excess pressure is created in the tank.

Fig. 8.2 shows a diagram which foresees the arrangement of a special device with nozzles on the water supply pipe either on top of the future tank or moving along the height of the tank.

This device rotates slowly.

Jet washing with atmospheric pressure in the tank is used for creating tanks at comparatively shallow depths (300-400 m) in conditions of salt deposits of high hardness. The creation of elevated air pressure in an underground chamber provide for stability of a cavity at great depths.

The air pressure in the cavity is determined on the basis of the necessity of providing for stability of the underground chamber and for forcing the brine to the surface. If the pressure in the cavity is higher than the calculated pressure, which may be determined by a manometer reading, the excess air is expelled and the pressure lowered. The required pressure may be maintained automatically.

Comparative data on the circulation and water-jet methods of washing are given in Table 8.2

TABLE 8.2

Indicators	Washing Methods	
	Circulation	Water Jet
Height of dissolving area, M	10.0	10.0
Washing capacity, m ³ /h	11.8	11.8
Volume of chamber, m ³	221.0	221.0
Washing time, h	530	122
Average mineralization of brine, kg/m ³	64.0	277.0
Water consumption per 1/m ³ of chamber, m ³ ...	28.4	6.54
Method of controlling formation.....	Use of non-solvent	Selection of water-jet parameters

The advantages of the jet method of constructing underground

tanks in rock salt deposits reduce to the following:

1. The creation of underground storage chambers of a given shape with a spheroidal roof as a consequence of imparting calculated trajectories to the jets.
2. High output, exceeding the output of the circulation method by 3-4 times.
3. Washing proceeds without the use of a non-solvent, which provides greater economy and significantly simplifies the process.

Washing Out Tanks of the Gallery Type

Numerous rock salts deposits have strata 5-20 m thick. Washing out tanks of low height and, consequently, of small volume, through vertical bore holes in such strata is economically unprofitable. In foreign countries salt strata of such thickness are not used for creating underground storage areas.

O. N. Ivantsov and Yu. S. Vasyuta have developed a method of creating underground tanks in such strata. The essence of this method reduces to drilling inclined-horizontal (inclined-directed) bore holes and washing out gallery (tunnel) chambers along the strike of a thin strata. Because of the great length of the underground chambers, even if they are of short height, it is possible to create large tanks with their long-term stability guaranteed. Methods of washing out such a tank are shown in Fig. 8.7.

Usually dense anhydrites are the enclosing rocks of thin salt strata. If they have jointing it is necessary to locate the cavity in the bed so that the enclosing rocks are completely covered with rock salt 2-3 m thick. In order to preserve the salt pillar below the chamber, the horizontal branch of the bore hole

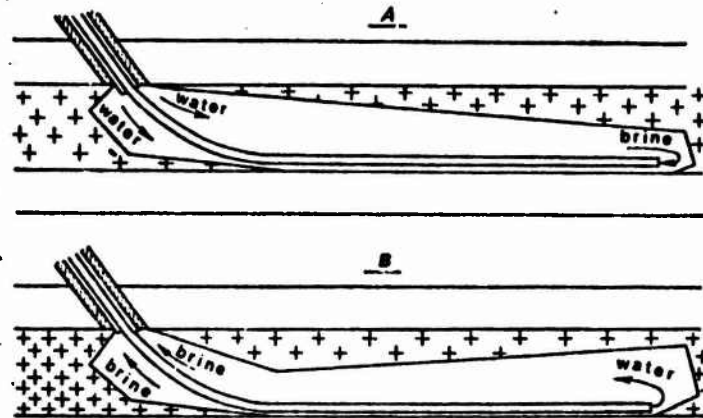

Fig. 8.7. Methods of washing out gallery tanks.

A - Counter-flow; B - direct flow.

is drilled the indicated distance above the foot of the bed. Below the bore hole there will be practically no washing away of the salt and the pillar will be preserved.

The upper protective pillar may be preserved during washing by using a predetermined leaching program.

Thus, in a rock salt bed with jointed enclosing rocks the height of the chamber H_c is

$$H_c = H - 2a, \quad (8.18)$$

where H is the thickness of the salt bed in m; a is the protective salt pillar in m.

Since usually the volume of an underground tank is predetermined, its height limitation influences the length l , since the ceiling span (width of the tank) B and, consequently, the cross sectional area S are in direct relationship to the height of the tank.

The length of the chamber is

$$l = v/s.$$

(8.19)

Inclined-horizontal bore holes are drilled by the rotary method or with the use of facing machines (turbo-drills or electric drills). The second method provides for a higher drilling speed and significantly shortens lowering-raising operations.

Accurate driving of the bore hole is very important for successful leaching out of a tank. The uncased part of the bore hole must pass immediately adjacent to the base of the rock salt bed in order to provide the greatest tank height.

A two-column system without the use of a non-solvent is used for washing out tunnel tanks. The shoe of the casing column is installed on the roof of the bed. The working pipe column is lowered into the drilled bore hole up to the face. Tunnel tanks are washed out according to the following methods.

1. Leaching with an immobile position of the working pipe column.

Water is supplied through the central pipe column, and brine is removed along the space between the pipes--direct flow conditions (see Fig. 8.7)--or water is supplied along the casing pipe and the space between the pipes, and the brine is removed along a central pipe--counter-flow conditions. In the case of leaching by direct flow or counter-flow the cross sectional areas (dimensions) decrease in the direction of motion of the solvent. Consequently, it is necessary to change the washing regime periodically in order to obtain a chamber of uniform cross section. However, this simple method may be used only in pure salt. In contaminated salt the working column will be clogged with a counter-flow regime.

2. Leaching out a tank with periodic movement of the working pipe column (Fig. 8.8).

In contaminated salt it is possible to obtain a chamber with

a uniform cross section along its length by washing with periodic movement of the working pipe column back toward the mouth of the bore hole, that is, by gradually drawing the working pipe out of the bore hole.

The entire length of the tank to be washed out is divided into equal sections. The shoe of the working pipe column is set at the ends of these sections for washing out the next bite. From each position of the working pipe column leaching continues until the underground chamber in the vicinity of the shoe reaches the planned dimensions. Previously washed out sections are not significantly dissolved when washing out following sections.

This method may be used to create a chamber with different sized cross sections.

The washing methods, indicated in § 1 and 2 are the principal ones.

3. Leaching out an underground tank by means of connecting inclined-horizontal and vertical bore holes. This method may be used for creating large storage areas.

Washing out numerous model tanks, opening and investigating test tanks washed in rock salt through inclined-horizontal bore holes have made it possible to determine the shape and cross sectional dimensions of tunnel chambers (Fig. 8.8). They have a horizontal ceiling, side walls inclined at an angle of 75-80° to the horizon and the bottom faces are inclined to the horizon at a 5° angle. The ratio of the ceiling span to the height of the chamber $B/H = 1.20$.

In rock salt bed deposits with dip angles of 20-40° underground tanks may be arranged along the dip of the bed, along the

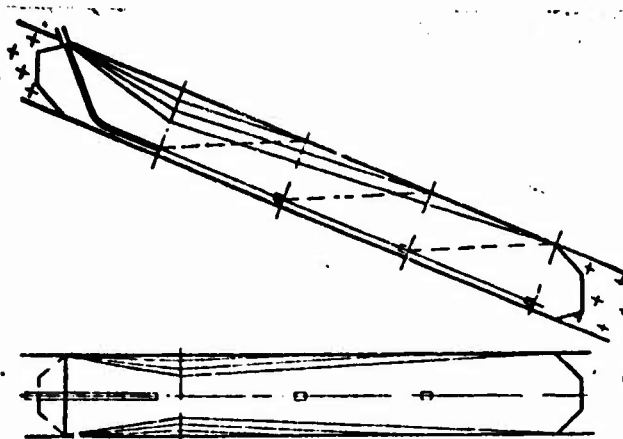

Fig. 8.8. Diagram of washing out a gallery tank with periodic movement of the working pipe column.

rise or along the strike. The cross sections of chambers in such beds have some differences as compared with the cross sections of chambers in horizontal beds. Thus, instead of bottom surfaces at an angle to one another there is a horizontal area and the roof is more rising.

Determining the Volume and Shape of Underground Tanks.

In constructing and using underground storage areas it is necessary to determine the volume and shape of the underground chambers. It is practically impossible to determine the actual shape and dimensions of a chamber by calculation because of the complexity of the hydrodynamic washing processes, the anisotropy of the salt and the presence of intercalations.

The volume of a chamber may be determined according to the amount of water pumped, the brine removed and its concentration. For this the amount of water pumped into the bore hole and the brine removed from it are determined continuously while washing out the chamber, and also the density of the brine is determined at uniform intervals. According to these data the volume of the chamber may be calculated at any moment during the leaching process. The electrostrictive effect is considered when determining the volume.

The method of determining the cross sectional of a chamber at different levels according to equilibrium pressures has become common. This method is based on the principle of hydrostatic equilibrium in a chamber filled with an oil product or liquefied gas and brine. Since the product stored is lighter than brine at the mouth of the bore hole (casing column), there will be excess pressure at the gate valve on the product conducting pipe. With a decrease in the level of the product-brine contact, that is, upon filling the chamber with product, this pressure increases.

The equilibrium state, depicted in Fig. 8 9, may be described with the equation

$$h_c = \frac{p}{\rho_b - \rho_p} 10, \quad (8.20)$$

where h_c is the depth to the product-brine contact in m; and p is the internal pressure in the underground tank (pressure at the mouth of the casing column) in kg/cm^2 .

$$\Delta h_c = \frac{\Delta p}{\rho_b - \rho_p} 10, \quad (8.21)$$

where Δp is the increase in pressure at the mouth of the casing column; Δh_c is the increase in depth (change in the product-brine level).

Then for a unit volume of a chamber of the height Δh_c the mean radius R_c (in the case of an axisymmetrical chamber) is defined as

$$R_c = 1.772 \sqrt{\Delta Q_p / \Delta h_c}, \quad (8.22)$$

where ΔQ_p is the volume of product introduced for filling the new chamber volume with an increase in depth by Δh_c , in m^3 .

By forcing out the brine with the oil product or liquefied

gas from the chamber with accurate measurement of the product on the pressure at the mouth of the casing column it is possible to calculate the radius and, consequently, the area for a number of chamber cross sections. However, this method does not make it possible to determine the assymetry of the washed out chamber and the cross sectional radius.

In the case of washing with the use of a liquid non-solvent, when the washed out chamber volume is filled with product, it is possible to measure the mean cross sectional radius of the chamber by means of measuring the depth of pumping to the boundary of the non-solvent and repeated measurement of the non-solvent-brine level. Knowing the change in the level of the non-solvent and its volume it is possible to find the average chamber radius and the average cross sectional area for determining the volume.

The non-solvent-brine level is determined by various methods: by the under-shoe method, by the control pipe method, by the electrical method based on the conducting properties of brine and the dielectric properties of hydrocarbons, by radioactive logging, etc.

The under-shoe method is one of the most simple and reliable ones. The essence of this method is that the non-solvent in a chamber is maintained at the level of the water supply column. The level is checked by stopping washing by means of pumping the non-solvent until it no longer floats up and does not appear in the water supply pipe column at the wellhead, which indicates that it is located at the level of the water supply column shoe.

Electrical contacts, which are located on the water supply pipe and connect a cable, a signalling electric light on the surface. When the level of the non-solvent-brine interface moves upwards, the contact enters the brine and the light turns on.

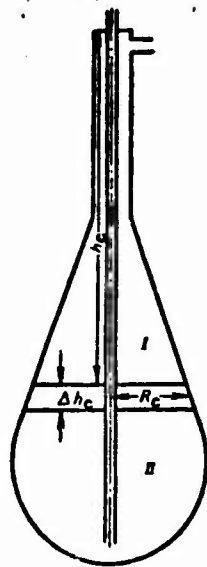

Fig. 8.9. Diagram of determining the capacity and dimensions of a chamber by the equilibrium pressure method. 1 - liquefied gas; 2 - brine.

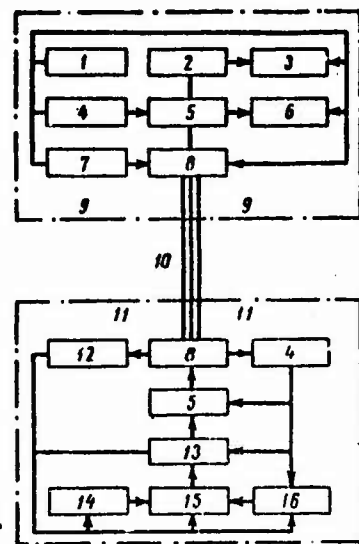

Fig. 8.10. Block diagram of a sonar system for measuring leached-out chambers. 1 - stabilizer; 2 - demodulator; 3 - automatic recorder; 4 - power unit; 5 - amplifier; 6 - oscillograph; 7 - control panel; 8 - filters; 9 - instrument bay; 10 - cable; 11 - well equipment; 12 - mode relay; 13 - azimuth information; 14 - rotation mechanism; 15 - acoustic system; 16 - generator.

Radioactive logging is used most widely for determining the oil-brine boundary.

All the methods of measuring the shapes and volumes of underground chambers washed out of rock salt, described above, are indirect. They make it possible to obtain only the average radius of an actual cross section, which does not characterize the true shape of a tank since insoluble inclusions, intercalations and anisotropy of the salt make asymmetrical development of a tank very probable.

Direct measurement of underground chambers is performed by sonar. A sonar set consists of two basic parts (Fig. 8.10): well equipment and an instrument bay.

The well instrument is lowered into the well along a pipe column 100-150 mm in diameter. A variation of circular scanning in the horizontal plane is used for taking a sonar-survey of the chamber. Emitting intermittent sound pulses, part of the instrument rotates continuously. A receiving-emitting convertor receives the signals reflected from the chamber walls, which signals are displayed on the surface of a cathode tube screen and are photographed or recorded on a circle diagram.

An ultrasonic instrument measures the time necessary for the passage of the signal sent from a deep vibrator to the tank walls and back. Knowing the time and propagation speed of oscillations in the brine, the distances are determined and an outline of the cross section at a specific depth is sketched for each revolution.

The magnetic meridian is determined with an azimuth sensor, which makes it possible to orient the cross section exactly. The directional signal transmitted by the instrument each time it passes magnetic north is displayed on a cathode tube.

Soviet ultrasonic instruments make it possible to survey to a depth of up to 1.5 km. They provide for measuring the outline of tanks 100 m in radius, giving an accuracy of 2-3 %.

Strength of Underground Tanks in Rock Salt.

Leached-out chambers--excavations made by washing, must be considered to be major constructions, designed for a long period of use. They must be stable and sealed during the entire period of use.

The formation of cracks and the leakage of gas through them may create danger for above-ground structures. Collapses and cave-ins may cause the loss of a great amount of valuable products and put the underground tank out of commission.

In designing underground storage areas without reinforcement, the properties of the natural materials are the basic data, therefore in each specific case it is necessary to study the mechanical properties of the rock.

The strength of chambers is evaluated by the probability of the appearance of collapses. In the case of locating underground tanks at great depths, consequently, in conditions of high rock pressure, the most favorable chamber shapes from the point of view of strength are spherical and spheroidal.

The probability of collapse, that is, the probability of the non-fulfillment of the strength criterion, is

$$V = \frac{1}{2} - \frac{1}{\sqrt{2\pi}} \int_0^{\Delta} e^{-\frac{z^2}{2}} dz, \quad (8.23)$$

where $\Phi(\Delta) = \frac{1}{\sqrt{2\pi}} \int_0^{\Delta} e^{-\frac{z^2}{2}} dz$ — is the Laplace function.

The quantity Δ is called the safety characteristic whereby

$$\Delta = \frac{n-1}{\sqrt{n^2 V_{com}^2 + V_e^2}}, \quad (8.24)$$

where V_{com} and V_e are respectively the coefficients of variation of the compressive strength and effective stress; n is the strength safety factor, determined by the mean value of $\bar{\sigma}_{com}$ and $\bar{\sigma}_e$ according to the formula

$$n = \bar{\sigma}_{com} / \bar{\sigma}_e. \quad (8.25)$$

In designing underground storage areas the greatest radius

of spherical chambers is determined, and the pillars between the chambers are chosen so that the influence of one chamber on another is practically excluded.

§ 2. Underground Storage Areas of the Shaft Type

In regions where there are no salt deposits suitable for constructing liquefied gas storage areas it is possible to construct shaft tanks in monolithic sedimentary, metamorphic, and igneous rock. It is necessary that these rocks have minimum porosity and jointing, a permeability of not more than 100 md, sufficient strength, and also are easily worked. The following rocks are most suited for the construction of underground shaft tanks: sedimentary (dense limestones, dolomites, gypsum, chalk, aleurites, argillites, etc.), metamorphic (clay schists and slates, quartzite, siliceous schist, etc.), igneous (granites, etc.). It is possible to use sandstones and other porous or locally jointed but stable rocks, if they can be efficiently and cheaply insulated.

The greatest number of shaft storage areas for liquefied gas are constructed in clay schists, limestones, chalk and granites.

In order to determine the depth of location above a tank a calculation is performed, the basic condition of which is to provide counter-pressure of rock to the vapor pressure of the gases. For rough calculations the counter-pressure to an excess gas vapor pressure of 1 kg/cm^2 is taken as equal to rock bedding 6 m thick.

Starting from these conditions and bearing in mind the temperature conditions of underground storage, tanks for liquefied hydrocarbon gases may be located beginning at a depth of 60-70 m.

Construction of Shaft Storage Areas

Shaft storage areas for liquefied gas are an underground tank or a group of tanks and a complex of aboveground structures (Fig. 8.11). In individual cases a liquefied gas regasification installation is located in the immediate vicinity of the storage area.

The underground part of shaft storage areas for a liquefied gas consists of vertical excavations (shafts or bore holes of large diameter, excavations around the shaft, chambers or horizontal excavations--the storage area proper). Bore holes for pumping the product into the tank are drilled around the edges of the storage area.

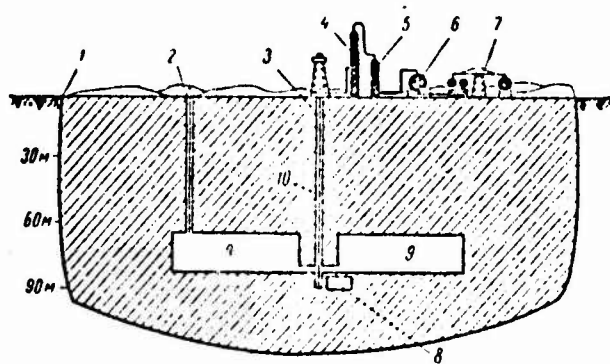

Fig. 8.11. Basic diagram of an underground shaft storage area for liquefied gas.

1 - surface; 2 - pipeline for pumping product; 3 - shaft; 4 - fractionating column; 5 - dehydrator; 6 - intermediate tank; 7 - loading dock; 8 - pump; 9 - underground tank; 10 - pipeline for supplying product.

In constructing an underground shaft tank vertical or inclined excavations open up the rock bed in which the storage area is to be located. Vertical excavations for constructing storage area serve for the lowering and raising the work equipment and workers, in removing rock, for ventilation purposes, the installation of water drainage pipes, cables, etc. Pipelines and pump cables are installed in them when they are in use.

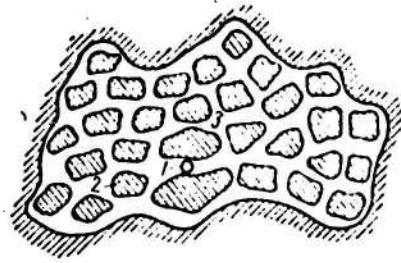

Fig. 8.12. Plan of underground gas storage area of the cell type.

1 - shaft; 2 - pillar; 3 - tank excavations.

When excavation work is finished the storage facility is provided with processing equipment and pipelines, control and measuring instrument systems are installed, and final testing of the storage area is performed. Installation and facilities for lowering equipment and workers are provided for repair and performing inspection.

Cell-type storage areas also are constructed (Fig. 8.12). In this case the underground tank has the shape of a rectangle, square or is irregular. The roof of the excavations is supported by rock pillars. The shaft is located in the center and a sealing layer is set up only in the shaft. Sometimes the roof between pillars is strengthened with anchor bolts.

Sinking Vertical Shafts

The shafts of underground shaft storage areas are sunk to depths of from 60 to 200 m. They are constructed with a small cross sectional area and are made water-tight.

If when in use the storage area is used for storing liquefied gas (Fig. 8.13, a) the construction and materials of the casing must guarantee that the shaft is gas-tight. In such cases usually steel casing pipes are cemented up with special solutions are used.

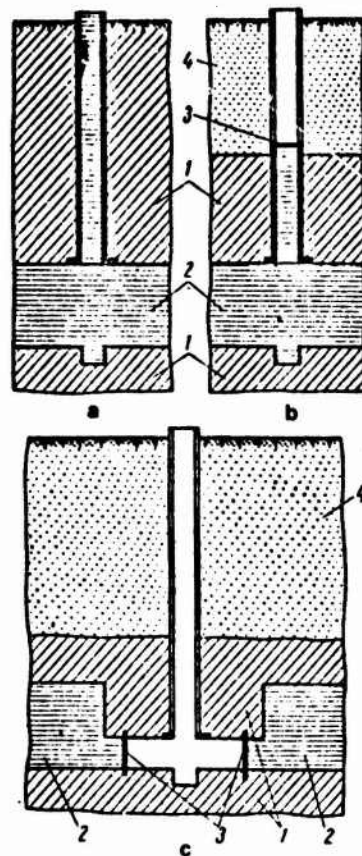

Fig. 8.13. Shafts of underground storage areas used when the storage areas are in use.

a - as a tank; b - partially as a tank; c - only for the location of communications and equipment; 1 - working layer of rock, impenetrable for products stored; 2 - tank excavations, filled with product; 3 - hermetic seals; 4 - upper permeable rock.

If the shaft is partially used as a tank (Fig. 8.13, b), the same requirements, as in the preceding case, are imposed on the hermetic sealing of the shaft, and the construction of the shaft above the seal must be watertight. Only in exceptional cases, in very complex geological conditions is it permitted for an insignificant amount of water to enter the shaft. In this case it is necessary to set up a ring collecting system with a water intake and an automatic pump system for pumping out the water.

If the shaft is not used as a tank and the hermetic seal is located in the excavations around the shaft, as is shown in Fig. 8.13, c, these requirements are retained only with respect to watertightness. Here, also, an insignificant inflow of water is permitted in exceptional cases. Communications and equipment in

the shaft must have reliable protection from corrosion.

The sinking of vertical shafts is connected with difficulties arising because of the limitation of the working area due to the small dimensions of the shafts. With respect to the labor costs the sinking of vertical shafts has great importance in the construction of a storage area (up to 30-50% of the cost). Usually 40-50% of the total construction time is spent in sinking shafts.

Since when a tank is in use is sufficient to have a shaft of minimum dimensions, comprehensive technical-economic analysis has shown the advisability of sinking shafts of minimum diameter, even at the expense of speed of construction.

Vertical shafts for storage areas are sunk by the usual tunnelling, drilling-blasting methods, by the drilling method, and in complex hydrogeological conditions with the aid of a caisson or artificial freezing.

Vertical excavations of square or round cross section up to 4 m in diameter are sunk by the drilling-blasting method. In this case the debris from the shaft is removed with buckets up to 1 m³ in volume. In sinking horizontal excavations a lifting guage is installed and the rock is removed in skips or in shaft cars.

Sinking shafts by drilling is more progressive, since in this case all operations of breaking and removing rock are completely mechanized. With manual labor 60-70% of the time of the sinking cycle is consumed in the latter operation.

The shafts for storage areas are drilled with the rotary equipment with rolling-cutter bits, used for sinking oil wells, but modernized and adapted to the specific conditions of shafts for underground tanks. Drilling is performed according to a

multi-stage scheme, first a pilot hole is drilled, then it is expanded to the planned diameter. Shafts 1.3, 1.5 and 1.8 m in diameter are sunk by rotary drilling.

Shafts are reinforced with steel pipes with walls 15-18 mm thick. Pipes are sunk in sections 6-12 m in length connected by welding. Ventilation pipes and pipes for the passage of a high-voltage cable are welded from the outside to the casing pipes before sinking them. Pipes for supplying the solution for cementing the space around the pipes are located in the same place. The diameter of the pipes arranged around the outside of the casing pipe is 38-50 mm. This solution makes it possible to free the useful cross section of the shaft from pipes and cables and to avoid accidents when sinking the shaft and moving loaded buckets with rock and lowering equipment along it.

The casing pipe is lowered onto a sand cushion which is created when drilling is finished by means of sprinkling sand down the shaft into a clay ballast. A concrete seal 1.5 m thick is made in the bottom (first) casing pipe before sinking the column so that the ballast is forced out.

The sand cushion and concrete seal facilitate the operations of cementing the attachment area. Cementing is performed in order to prevent corrosion of the casing pipes, the migration and breakthrough of water from water-bearing layers into underlying beds and the creation of a continuous contact between the rock and the casing pipe. Cementing is performed in the usual method, applying cements with additives increasing its density and hardness.

Upon finishing cementing the sand is pumped or raised up in buckets. The ballast covers the bottom of the shaft to a height of approximately 10 m, and after its removal the unfastened section of the shaft is revealed, which immediately makes it possible to begin sinking the shaft bottom.

The optimum shaft diameter is 1.3 m (in the rough). This is the minimum possible shaft diameter for lowering and raising people, mining and rock removal equipment.

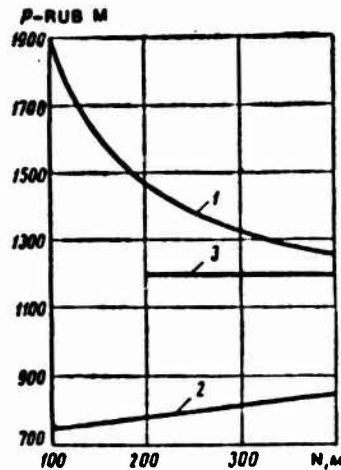

Fig. 8.14. Graph of the cost of sinking a 1m shaft.

1 - with a UKB-3.6 unit;
 2 - by the usual method (sinking a 3.6 diameter shaft);
 3 - with a RTB-2.08 unit.

In the case of a storage area with a volume of more than 25,000 m³, in addition to the main shaft, two ventilation shafts are sunk, and in the case of a volume of above 35,000 m³—three and more ventilation shafts.

A graph of the cost of the different methods of sinking shafts is shown in Fig. 8.14. In the graph it is obvious that drilling shafts is cheaper than sinking shafts by other methods.

In individual cases adits are used as stripping excavations. This is possible in conditions of very rugged terrain in the case of side cutting in a storage tank.

Driving Horizontal Excavations

Underground tanks are a system of interconnected horizontal excavations having a slope towards the shaft or away from it in

relation to the plan of filling-draining operations. In order to provide for stability of underground tanks, subjected to the pressure of overlying rock, rock pillars are left in the process of driving them.

In driving horizontal excavations in an area intended for a storage tank, 30-70% of all rock is removed, and the remaining 70-30% is left as safety pillars. The number of safety pillars depends on the stability of the rock. In clay schists usually not more than 35% of the rock is removed, and in granites 70-65%, leaving 30-35% as pillars.

Depending on the volume of the tank, the strength of the rock and the dimensions of the excavations, storage tanks occupy an area of 1000-10,000 m². Since horizontal excavations are driven in stable rock, their cross sections reach dimensions of 30, 60, and 80 m². The height of the excavation may be from 4 to 12 m and the width from 4.5 to 7.5 m.

In rocks of low stability, in order to avoid reinforcement, minimum dimensions are used. The shapes of the cross sections of excavations for underground storage tanks are shown in Fig. 8.15. Tank dimensions are chosen depending on the mechanical properties of the enclosing rock.

Anchoring is used for reinforcing the rock. The term anchoring is understood as meaning the artificial strengthening of the rock surrounding an excavation by means of fastening individual beds and stratifications of the component rock with anchor bolts with cross braces. A large number of different types of anchor bolts are used, but the principal ones are wedge-slot and stay-wedge bolts (Fig. 8.16).

In driving a wedge-slot bar into a drilled hole the feathers of the top part of the anchor, sliding along the inclined surfaces of the wedge, move apart.

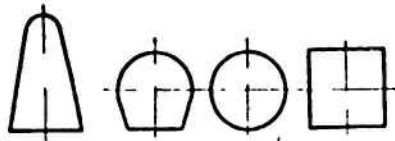

Fig. 8.15. Shape of cross sections of excavations of underground storage tanks.

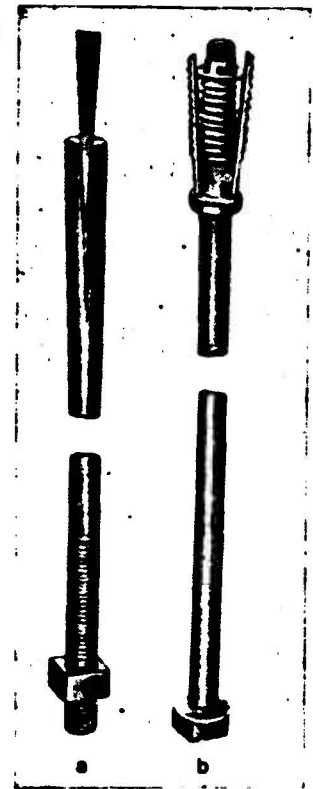

Fig. 8.16. Anchor bolts:
a- wedge-slot; b - stay-wedge.

As a result, the more the wedge penetrates the slot of the anchor bolt the more its upper end presses against the walls of the hole, by which secure attachment of the anchor in the hole is achieved.

A stay-wedge anchor expands when the bolt is screwed into the hole. In this case the feathers move apart as a result of their sliding along a collet.

Wedge-slot anchors attach better in strong, but not hard rock. In very strong and in weak rock stay-wedge anchors usually are used.

Anchor bolts are 1.2-1.8 m long and have diameters of 18-24.5 mm.

Excavations are reinforced with anchor bolts by lagging the roof and walls with a metal screen, with bearing plates, with channel or round reinforcement cross braces and by gunniting the walls over a metal screen.

The surface area per bolt depends on the stability of the rock and amounts up to 3 m^2 .

Mechanisms of special construction with caterpillar or penumatic drive are used in excavation. Also mechanisms on rails are used in excavations of great extent. In this case hauling is performed with mine electric motors and cars.

Excavation without reinforcement is performed with the full cross section, and in the case of large cross sections--with a stepped base. Most often the rock is broken by the drilling-blasting method with weak explosive charges so that breaks in the continuity of the rock along the periphery of the excavations will be minimal. Low strength explosives are used.

The cost of shaft storage areas depends on their volume. With a range of variation of the volumes of underground storage areas from 25,000 to 100,000 m^3 the cost of 1 m^3 of capacity in base coverage varies from 54 to 18 rubles. In this case the cost of excavation amounts to from 40 to 61% of the total cost of the storage area.

Underground storage areas of the shaft type are efficient only in exceptional favorable conditions with the creation of very large storage areas.

§ 3. Ice-Dirt Storage Areas for Light Oil Products

A great amount of oil products is required for the developing economy of the extreme north and northeast of the USSR. Fuel is transported to these regions primarily by tankers during the very

short period of summer navigation. Therefore it is necessary to have a large number of tanks of significant volume ensuring an annual fuel reserve.

It is technically complex and expensive to construct and use metal tanks in these regions because of the low air temperature and strong winds. There are cases of steel tanks being destroyed. Therefore casement metal tanks which are more reliable are constructed in a number of places. However, they consume a great amount of metal and their cost is very high.

In connection with this methods of constructing underground storage areas in permafrost deposits were proposed and developed. Two types of underground tanks are constructed: a - shaft (Fig. 8.17) and b - trench with an ice-free cover (Fig. 8.18). In order to exclude direct contact of the oil products stored with the bedding of permafrost soils and to seal the underground tanks securely they are faced with ice.

The physicochemical properties of oil products and their commercial qualities practically do not change after long contact with ice. Excavations made in permafrost retain stability for a long time. Ice-dirt storage areas are best constructed in finely dispersed non-saline ice-saturated loamy soils, having a total moisture by weight of not less than 20%. The frozen soil must have long-time strength ($3-5 \text{ kg/cm}^2$) which can provide stability of the storage chambers without the installation of reinforcement. The temperature of the ground in which a tank is located must not exceed -2° C . The tank is located at minimum depth since even in storing fuels with a high vapor pressure with a minus temperature of the surrounding ground, no significant excess pressure is created in the tank.

Sites for constructing ice-dirt storage areas are located no closer than 50 m from rivers, bodies of water, and water-bearing layers--natural sources of heat. The construction of a storage tank and the methods of performing construction work are chosen

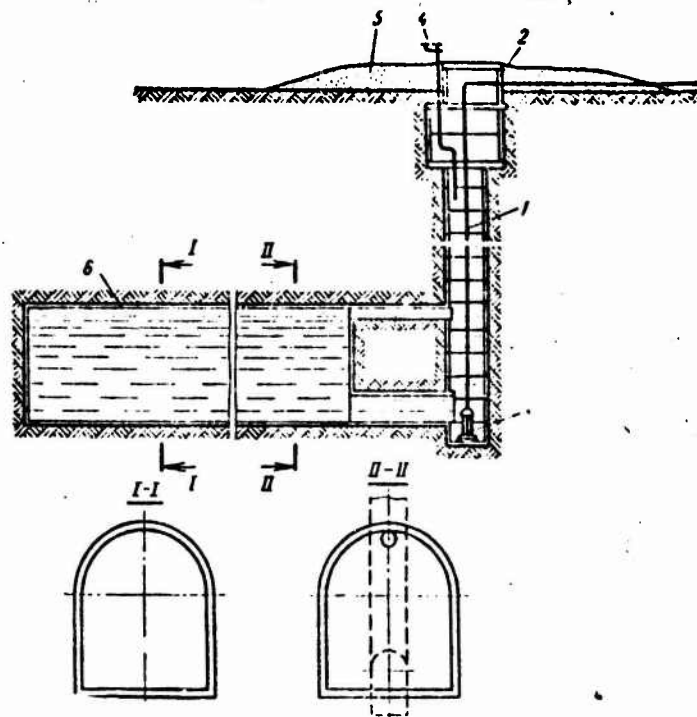

Fig. 8.17. Schematic diagram of an ice-dirt storage area of the shaft type for one product.

1 - shaft; 2 - head; 3 - submerged pump; 4 - breathing valve with fire-safety device; 5 - heat insulation dirt cover; 6 - ice facing.

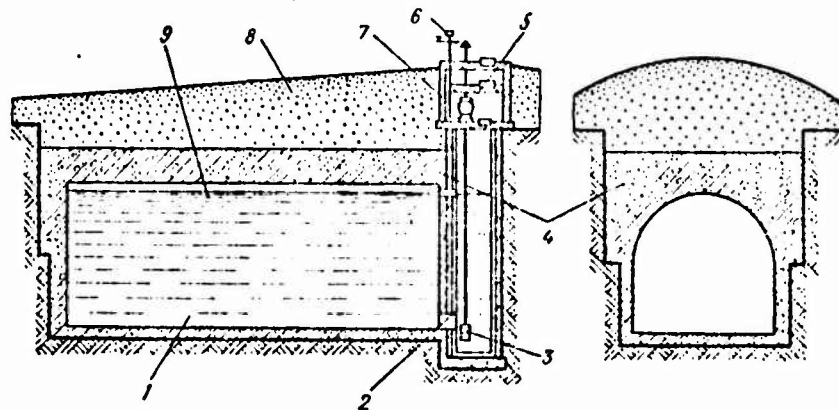

Fig. 8.18. Schematic diagram of ice-dirt storage area of the trench type.

1 - tank chamber; 2 - service well; 3 - artesian-type pump; 4 - ice cover; 5 - electric motor; 6 - breathing valve with fire-safety device; 7 - head; 8 - heat insulation dirt cover; 9 - maximum level of oil product.

depending on the geological and geocryological conditions of the specific region, the purpose and volume of the storage area.

An ice-dirt storage area includes underground chambers (with tanks proper), opening excavations in shaft storage areas, cooling equipment, above ground buildings and structures, access roads, engineering communications, and pipelines.

Shaft tanks may be constructed for storing several products in different chambers (Fig. 8.18). In this case the dimensions of the inter-chamber columns for providing long-term stability of the tanks are made no less than 15 m in diameter.

The opening excavations, serving as construction approaches, and also for operational purposes, are made in the form of vertical or inclined (Fig. 8.80) shafts depending on the local terrain. The minimum shaft cross section is used.

The mouths of the opening excavations are strengthened with permanent reinforced concrete or metal reinforcement. The reinforcement is calculated according to the usual method for calculating such structures.

In order to make it possible to completely evacuate the tank chambers of product and the vapors formed, tanks are constructed with a longitudinal slope of not less than 0.002 toward a sump pit in the shaft from which the product is pumped.

The highest points of the chambers may be connected with the surface by a drilled breathing hole. The tank is equipped with a breathing pipe so that gas "pockets" do not form.

Chambers of circular, vaulted, or trapezoidal shape with rounded corners are designed. The width of the chambers is chosen on the basis of the depth of their location by analogy with long-standing excavations made in similar geological and geocryological conditions, but no more than 8 m. Chambers are faced with ice not less than 3 cm thick. The ice facing makes a leak-proof seal and protects the product from contamination by mechanical impurities.

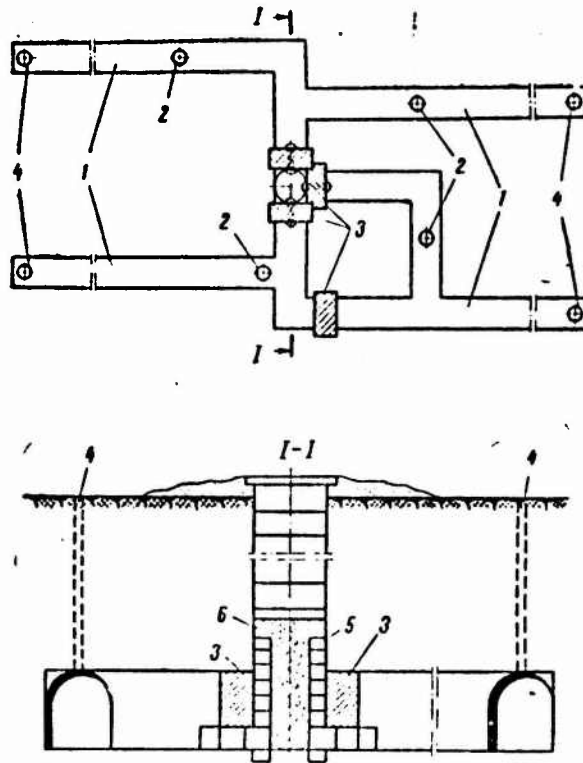

Fig. 8.19. Schematic diagram of an ice-dirt storage area of the shaft type for three types of product.

1 - Tank chamber; 2 - bore holes for pumping product; 3 - cofferdam; 4 - breathing bore holes; 5 - well for location of submerged pump; 6 - cofferdam of frozen soil in shaft.

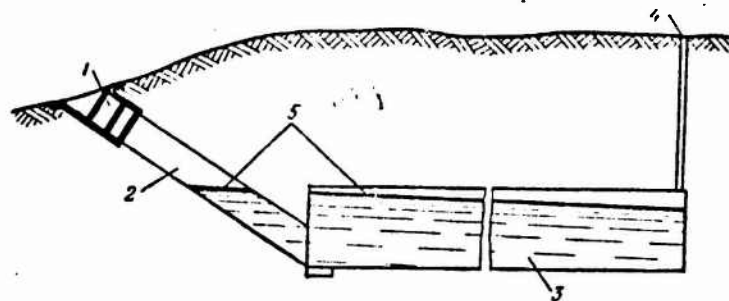

Fig. 8.20. Schematic diagram of ice-dirt storage area of shaft-type with inclined shaft.

1 - head of storage area; 2 - inclined shaft; 3 - tank chamber; 4 - breathing bore hole; 5 - maximum level of oil product.

However, not every ice facing corresponds to the requirements imposed. Rules concerning the formation of the microstructure of the ice in relation to the air temperature at which its freezing

occurs have been established for the creation of ice facing of the necessary quality.

The microstructure of the ice significantly influences its mechanical properties, and consequently, the strength of a structure made from the ice.

Not only the air temperature, but also the thickness of the layer frozen at the same time influence the dimensions of ice-crystals. In the case of low air temperatures the thickness of the layer of water frozen at the same time may be increased, in this case the structure of the ice formed does not change significantly, only the freezing process is accelerated.

Also, the freezing temperature influences the orientation of the axes of the ice-crystals. With a decrease in temperature the crystals attempt to occupy a perpendicular position relative to the freezing surface. Consequently, the lower the temperature during the freezing of the water is, the smaller the crystals and the stricter the orientation of the optical axes of the ice formed will be. Ice facing is frozen on only in the wintertime by the following methods:

a form is built and water is poured behind it or ice is laid and covered with water;

the facing is built up of ice blocks;

a fine spray of water is applied to the walls to be frozen.

Cold air is supplied into the chamber during the process of freezing on the facing.

Standard metal or wood forms are used for facing work. A wood form is covered with dense paper, tissue, or material and covered with water so that a thin ice crust is formed. Water at a temperature close to 0° C is poured behind the form in

small portions so that the thickness of a layer freezing at the same time does not exceed 1 cm.

To accelerate freezing, crushed fresh water ice in layers up to 10 cm thick is laid behind the form and covered with water to complete saturation. After each layer is frozen the freezing process is repeated.

Ice facing by the spraying method is performed after cooling the walls of the tank chamber with cold air supplied from the surface. Freezing is performed in thin layers, beginning with the top part of the chamber, then a stream of cold air is supplied along ventilation pipes directly to the point where the water is sprayed. Ice is frozen onto the bottom of the tank (dirt floor of the chamber in the last step).

The tank chambers of a shaft storage area may be driven even in the summertime. In this case it is necessary to insulate the entrance to the shaft carefully in order prevent warm air getting into it. In addition, it is necessary to force air, cooled to the temperature of the surrounding ground, into the excavations.

Trench ice-dirt storage areas are constructed with a negative air temperature. The widths of storage areas of this type is determined in relation to the rheological properties of the ice on the cover, but usually is not more than 5 m. The ice cover is made of spherical shape, resting on dirt benches no less than 1 m wide, made around the edge of the trench. The vault must have a thickness of not less than 1.5-2 m in the keystone.

The upper edge of the ice cover is located 0.5 m below the active layer. Frozen soil, a layer of turf or other heat insulating material is laid on top of the ice cover. The heat insulation is designed to maintain a temperature of no higher than -3°C on the ice surface of the vault.

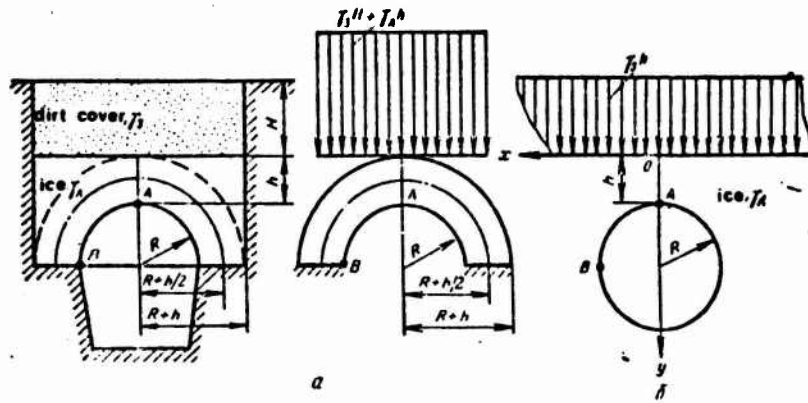

Fig. 8.21. Diagrams of ice-dirt trench storage areas and design diagrams.

All structure made of ice deform with time even with an invariable temperature and constant load. K. F. Voytkovskiy proposed that this deformation be assessed in the following way. By the simplest methods of the strength of materials the elastic displacement of characteristic points of a structure, depending on the elastic constants of the material, is found: the Young's modulus E and Poisson's ratio.

Into the expression obtained for displacement instead of E we substitute the reduce Young's modulus $E_{r.i.}$, defined as

$$E_{r.i.} = \frac{2(1+\mu)\eta}{t}, \quad (8.26)$$

where η is the water-content coefficient of the ice; t is the time.

The above-mentioned method and a design diagram for determining the elastic displacements of an ice vault were refined by L. N. Kisler and T. P. Makho. Design diagrams are shown in Fig. 8.21. In diagram a the ice cover is represented as an arch with built-in abutments, loaded with the total weight of the ice cover and dirt cover, and in diagram b the cross section of the storage area is seen as a round hole in a weighable half-plane, loaded

additionally on the edge by the weight of the dirt cover.

Since in diagram b the work of the entire block of ground around the storage tank (with the exception of the dirt cover) is considered, and the abutments of the arch are not considered to be imbedded, this diagram more fully reflects the actual work of the material of the structure.

Using the precise solution of the problem of elasticity theory for an isotropic uniform half-plane with a circular hole, located quite close to its boundary, and introducing the coefficient of viscosity of ice, the settling of the keystone ($\mu = 0.5$) is calculated according to the formula

$$\Delta_t = \frac{t}{2\eta} (\gamma_d H + \gamma_i h) R \left(\frac{R+h}{h} - \frac{R}{R+h} \right), \quad (8.27)$$

where Δt is the time in h; η is the coefficient of viscosity of ice in $\text{kg}\cdot\text{h}/\text{cm}^2$; γ_d is the volume weight of the dirt cover in kg/cm^3 ; γ_i is the volume weight of the ice in kg/cm^3 ; H , h , R are the geometrical parameters in cm.

A nomogram for determining the relative annual settling of the keystone is given in Fig. 8.22.

Let, for example, it be necessary to find the annual settling of the keystone of an ice-dirt storage area where $R = 3$ m, $h = 1.8$ m and $H = 4$ m. We find the parameters $h/R = 1.8/3.0 = 0.6$ and $h/H = 1.8/4.0 = 0.45$. A relative annual settling of $\Delta_{\text{ann}}/10^3 R = 6.8$ corresponds to the point of intersection of the vertical straight line corresponding $h/H = 0.45$ with inclined straight line $h/R = 0.6$. Since $H = 4$ m, we multiply the value obtained by $4/3$ (since the amount of the dirt cover is taken as different from 3 m). Then the relative angle of settling of the keystone is $\Delta_{\text{ann}}/10^3 R = 6.8 \cdot 4/3 \cdot 10^{-9} = 9.1 \cdot 10^{-3}$.

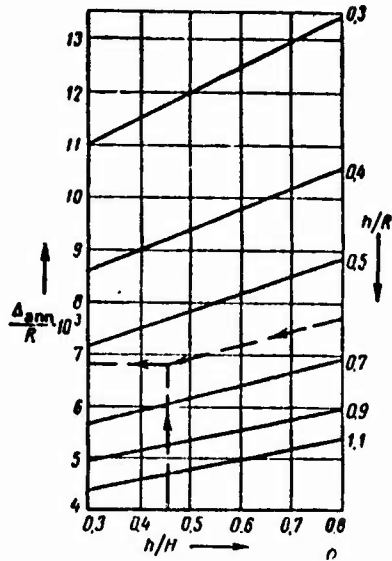

Fig. 8.22. Nomogram for determining the annual settling of the keystone of an ice-dirt storage area (applicable where $\gamma_i = 0.9 \text{ t/m}^3$; $\gamma_d = 1.8 \text{ t/m}^3$, $H_i = 3 \text{ m}$).

The absolute annual settling of the keystone is

$$\Delta_{\text{ann}} = 9 \cdot 1 \cdot 10^{-3} \cdot 3 = 0.027.$$

The annual settlements of ice storage areas have significantly greater values. For trench storage areas $\Delta_{\text{ann}}/R = 0.01$ is considered permissible.

Ice-dirt storage areas of the trench type have a service well which is made up of prefabricated reinforced concrete rings. The cross section of the well is determined in relation to the sump, and the volume and dimensions of the latter in turn depend on the type of pump, the service pipe lines, the level measurer, and other devices. In addition it is necessary to take account of the facilities for lowering people for inspecting and repairing the equipment.

The product to be stored is drained into the underground tank by gravity. The drain line ends in a sump or a tank chamber with a jet-breaking attachment for preventing mechanical and thermal action of the product on the ice facing. The product is removed from the tank with the aid of submerged or artesian pumps, and also jet units or ordinary pumps located in underground chambers.

A bulkhead which is divided into sections with fireproof partitions, is constructed above the well of a trench storage area and above the shaft mouth of a shaft tank. The operating equipment, automatic and control instruments, including instruments for controlling the temperature of the ice facing and the arch at different points are installed in the sections.

The electric motors located in the bulkhead are provided with forced ventilation, the arrangement of which must exclude the possibility of thawing the surrounding permafrost.

The storage area surface bulkhead is banked, banking being provided in a radius of not less than 10 m with slopes of 1 to 3. The banking, as also the heat insulation, is made of heat insulation materials: frozen soil, covered with turf and moss.

When constructing ice-dirt storage areas not only are grounds at a specific temperature chosen, but also temperature conditions are set up which are observed in constructing and operating the tanks.

It is very complicated to prevent disturbing the natural temperature conditions of the ground when filling a storage area with fuel with a positive temperature. Pre-cooling the fuel before draining it into the tank is connected with additional costs.

Oil products delivered by tankers along sea and river routes, arrive at a temperature of 8-15° C. In solving the problem of cooling them, in the first place we must consider the possibility of using ice and frozen soil. Ice has a high latent melting heat, by using which it is possible to obtain an efficient coolant. Fuel may be cooled to 0° C with the use of pure ice. If it is necessary to reduce the temperature of the oil product to a negative one, it is possible to use cryohydrate mixtures, that is, a mechanical mixture of snow or ice with different salts. Oil products also are cooled with the aid of compressors (the mechanical method).

Analysis of the different methods of cooling have shown that it is most economical to use natural cooling agents--frozen soil and ice, and in the coastal belt--sea ice. In individual cases, combined cooling is used, that is, the cold of the upper layers of the cryolyte zone (the cryogenic method) in combination with artificial cooling is used. As a rule, oil fuel is drained into

ice-dirt tanks at a negative temperature.

The reduced losses in cooling one ton of oil products by the cyrogenic method and with a drainage rate of up to $125 \text{ m}^3/\text{h}$ are less than in the case of the mechanical method. With an increase in the drainage rate the mechanical method of cooling is preferable. Thus, for a 39,000 ton depot with a drainage rate of $50 \text{ m}^3/\text{h}$ the reduced losses per one ton of the load cycle amount to 0.27 rubles per ton for the cryogenic method and 0.74 rubles per ton for the mechanical method, and with a drainage rate of $250 \text{ m}^3/\text{h}$ --respectively 1.21 and 1.06 rubles per ton.

Trench ice-dirt storage areas are more efficient than shaft storage areas with respect to capital investments and operating costs. The cost of 1 m^3 of a trench tank 200 m^3 in volume relative to the conditions of the north taking account of the framework, is 12.3 rubles while the cost of 1 m^3 of steel tank is 24 rubles; for $5,000 \text{ m}^3$ volume tanks the cost of 1 m^3 is respectively 10.7 and 15.8 rubles.

§ 4. The Use of Abandoned Excavations for Oil and Gas Storage

The use of depleted shafts, mines and quarries is of great practical interest for the underground storage of oil products and liquefied gases. However, the most common depleted coal shafts, as also slate shafts, are little suited for conversion to storage areas, since coal and slate do not possess sufficient strength, and it is necessary to reconstruct and maintain reinforcement in the shafts, while the rocks contain impurities of organic substances, soluble in hydrocarbons, and therefore lose strength under the action of oil products and liquefied gases.

In world practice there has been a significant amount of experience in the reequipping, successful utilization and sealing

of excavations in jointed rock with ground water. This type of storage of oil and gasoline is used especially successfully in Switzerland.

In order to provide for reliable sealing of the bottom and walls of excavations, located below the ground water level, which creates a backwater, preventing the leakage of product from the storage tank, are chosen. The ground water pressure on the walls and bottom of the tank must be higher than the pressure of the stored oil product on them. Since the density of oil and oil fuels is less than unity, then even if the ground water level insignificantly exceeds the level of the oil product stored, the necessary pressure difference is provided, guaranteeing against leakage of the oil product into the rock.

Leakage of water into the storage area is determined by the difference of the external and internal pressures. A constant pressure difference is maintained by means of periodically pumping water from the bottom of the storage area. Since the ground water conditions and the fluctuations of its level during the course of the year are known it is possible to determine the storage area operating conditions ahead of time.

Fig. 8.23 shows diagrams of underground tanks, closed on top but not sealed and graphs of the dependence of the pressure of oil and water on depth; Fig. 8.4 shows a diagram of an underground tank with the mouth sealed with a facing and Fig. 8.25--a diagram of an open tank filled with an oil product with a low vapor pressure.

Such storage areas are very profitable as regards utilization. The annual expenditures for storing oil products in these underground tanks amount to 30-40% of the expenditures in storing oil products in above ground tanks. This is explained first of all by the reduction in losses from evaporation. In storing heavy oils the expenditures for heating the oil during removal are reduced significantly.

Static pressure of water cushion of bottom

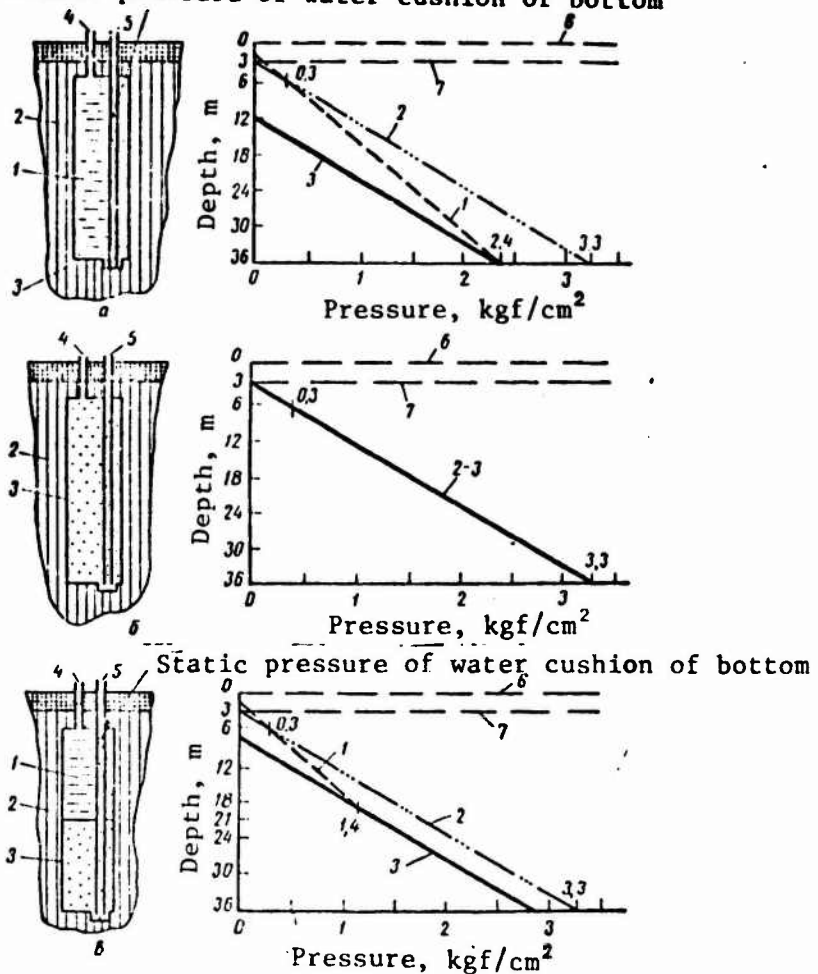

Fig. 8.23. Diagrams of underground tanks closed on top (unsealed) and a graph of the dependence of the pressure of oil and water on depth.

a - tank, completely filled with oil; b - empty tank; c - half-filled tank. 1 - oil; 2 - ground water; 3 - water cushion of bottom; 4 - oil pipe; 5 - water pipe; 6 - surface; 7 - top level of ground water. Note. In diagram b the level of the bottom water cushion coincides with the ground water level.

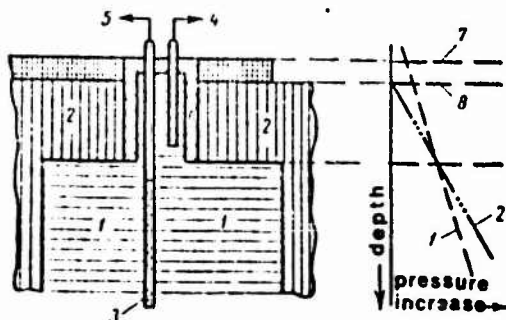

Fig. 8.24. Diagram of an underground tank closed on top (with mouth sealed) and a graph of the dependence of the pressure of oil and water on depth.

1 - oil; 2 - ground water; 3 - bottom water cushion; 4 - oil pipe; 5 - water pipe; 6 - facing of well mouth; 7 - surface; 8 - top level of ground water.

Slate quarries have been successfully used for storing heavy oil products in the USA. Here the products stored are sealed by means of arranging a water cushion in the tank and thanks to the backwater effect of the ground water.

The product level in such tanks always must be lower than the ground water level, which ensures movement of liquid only into the tank.

Fig. 8.25. Diagram of underground tank open at the top, filled with an oil product with a low vapor pressure and a graph of the dependence of the pressure of oil and water on depth.

1 - oil; 2 - ground water; 3 - bottom water cushion; 4 - oil pipe; 5 - water pipe; 6 - surface; 7 - ground water level.

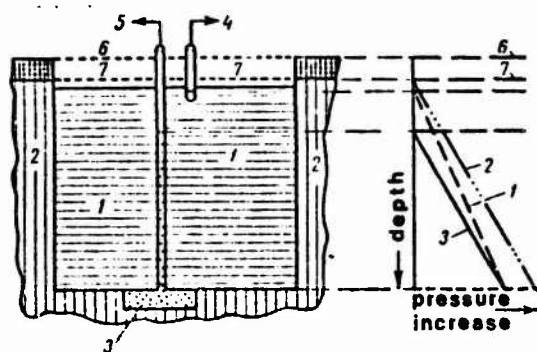

During a period of high consumption the oil product removed from the tank is replaced by water which is pumped under the level of the oil product. Another quarry is used as the water tank.

Several small control wells are drilled for daily observation of the water level in the tank and for the prevention of the penetration of water contaminated with oil into natural bodies of water around the underground storage area. Water samples are taken from these wells periodically and the presence of oil products in them is determined.

In equipping quarries for storing oil products the most complicated problem is that of installing covers to protect the product from contamination and evaporation. There are two cover constructions which are most suited for this purpose: 1 - a floating pontoon cover and 2 - a suspended cover.

A floating cover is of the same shape as the perimeter of

the quarry. This shape may be geometrically irregular. The cover consists of individual pontoons connected together. A suspended cover consists of steel sheets attached to a cable network. The cable network is suspended across the quarry.

There are a whole number of exhausted shafts where gypsum, rock, and potassium salts were extracted, including by the "meadowing" method (filling the chambers with water and subsequently pumping out the brine). These shafts do not require any additional sealing.

The solution of the adaptation of excavation for storage areas is connected with the specific conditions. The expediency of reequipping is determined by engineering-economical calculations. This, for example, the cost of reequipping a "meadow" $31,000 \text{ m}^3$ in volume on a rock salt deposit is 2.6 rubles per 1 m^3 of capacity.

§ 5. Underground Storage Areas Constructed by the Internal Blasting Method

In 1960 a new method of constructing underground tanks in bedded clays and loams by internal blasting was proposed. The essence of this method consists in drilling a bore hole to a planned depth into a bed of clay or loam encasing it with pipes to the top of the future tank. Then shooting charges are exploded in the bore hole. Thus intermediate basins for the location of the concentrated main charge are created. As a result of the complete camuflet explosion of the main charge, a cavity of spherical or spheroidal shape with dense hard walls is formed. During a camuflet explosion a plastic medium first compresses according to a given law, then deforms with the formation of an underground cavity, with no significant heaving, crack formation or other changes being observed on the top.

A diagram of the formation of underground tanks by internal explosions is shown in Fig. 8.26. Two preliminary shots before

the main explosion are shown in the diagram. This number of shots with charges of VV4 and 12-13.5 kg, respectively, for the first and second shots are used for constructing tanks of 100-150 m³ in volume with the explosion of a main charge of 450-600 kg at a depth of 20-22 m. the number of shots before the main blast depends on the physicomechanical properties of the specific clays and loams and the volume of the tank. With an increase in the volume and, consequently, in the main charge, the number of preliminary explosions increases. It is desirable that during shots the intermediate shot chamber for placing the main charge have a shape close to spherical since this shape to a significant degree determines the contours of the future tank.

The underground tank and intermediate shot chambers may be of a regular shape only if there is a uniform pressure distribution from the internal explosion, which can occur only in the case of an explosion in a completely closed unbounded rock mass.

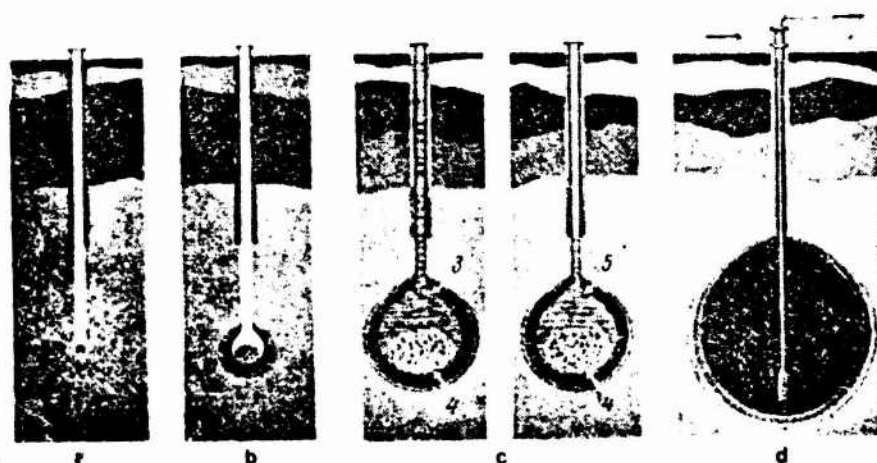

Fig. 8.26. Process flow diagram of the formation of underground tanks by internal explosions in deposits of bedded clays and loams.

Stages: a - first, b - second, c - third, d - finished tank; 1 - water tamping; 2 - initial charge; 3 - clay solution; 4 - main charge; 5 - cement solution.

In drilling the bore hole the closure of the medium is disrupted, therefore water tamping is used, that is, the bore hole and

shot chamber are filled with water to the surface before the first and subsequent shots, and also before the main blast. The water tamping increases the efficiency of the blast energy and protects the bore hole from its effects. It is even better to use a clay solution for hydrotamping. In the case of hydrotamping it is necessary to use only water stable explosives and water resistant blasting equipment.

The final choice of explosives depends on the physicochemical properties of the clays and loams, thus, for the formation of tanks in highly plastic soils explosives with throwing properties (pyroxilin powders) are used and in slightly plastic soils of the Cambridge clay type--highly explosive (ammonites, trinitrotolune, etc.). Fig. 8.27 shows the moment of explosion with the ejection of the water tamping during the formation of an underground tank in Cambridge clay with a 1.5 t charge.

In constructing underground tanks the shot charges and basic charge are exploded only by electrical means.

Clays of different genetic types and loams compact differently under the action of an explosion.

Plastic clays and loams are the most favorable for the creation of underground tanks by blasting since they yield irreversible plastic deformations under the action of the high pressures arising during an explosion.

At the present time comparatively rigid requirements for the rocks suitable for the creation of storage areas by means of blasting are in effect. The basic requirements are as follows: the clay particles (0.005 mm) in the rock must amount to no less than 15%, dust-like particles (0.05-0.005 mm) not less than 35% and sand particles (2-0.05 mm) not more than 40%, natural moisture 10-20%, porosity more than 30%, and the blasting index must be no less than $0.1 \text{ m}^2/\text{kg}$. In this case the plasticity number must be

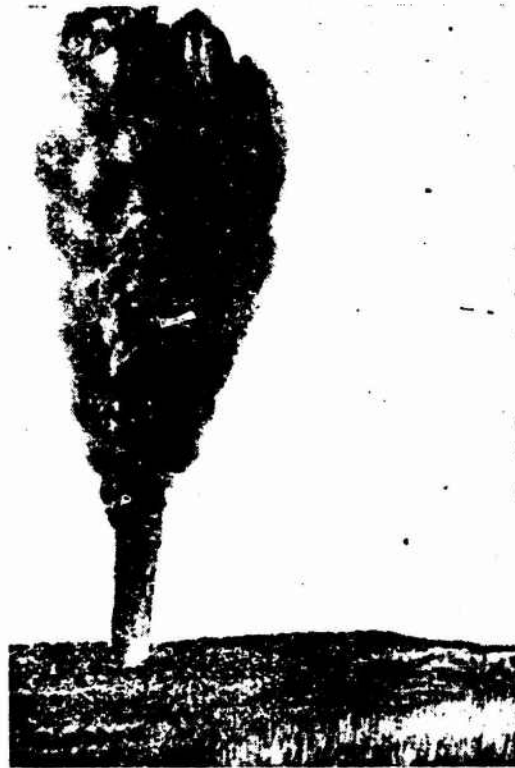

Fig. 8.27. Ejection of water tamping with the formation of an underground tank with the explosion of a 1.5 t explosive charge.

greater than 12.

Different oil products and liquefied gas practically do not change their commercial properties during long direct contact with very diverse clays and loams. Experience in storing diesel fuel in blasted cavities testifies to the sealing of the latter.

In creating stable underground tanks formed by means of internal explosions it is necessary to know the conditions for full camuflet blasting. It is important in this case to determine the minimum depth, since the cost and rock pressure depend on the depth of location of the tank.

The critical value of the internal explosion charge Q corresponds to the limiting (minimum) depth of placing the charge of a total camuflet.

The weight of camuflet charges is determined according to the formula

$$Q = qw^3 f(n), \quad (8.28)$$

where q is the specific consumption of explosive in kg/m^3 ; w is the line of least resistance of the blast in m ; $f(n)$ is the function of the index of the blast effect (for camuflet explosions it is assumed that $f(n) \geq 0.1$).

It is proposed that on the basis of an analysis of the result of test explosions the minimum depth of the center of the charge of an internal explosion be determined according to the formula

$$w = \sqrt[3]{Q/f(q, n)}, \quad (8.29)$$

where $f(z, n)$ is the function of the effect of the internal explosion, which for clays and loams fluctuates within the limits of 0.03-0.07.

It is necessary to note that the above-mentioned values of this function are obtained in the case of the explosion of charges from 100 to 1500 kg of unconditioned pyroxilin powders at depths of from 12 to 30 m. With a greater depth of explosion the value of the function will increase.

With the use of other explosions it is necessary to introduce a factor taking account of the equivalency to pyroxilin powder in efficiency into formula (8.29).

In the case of a stratified area the function of the effect of a camuflet blast is determined as the sum of the functions of the rock of all layers lying above the charge.

The tank volume V , obtained after the blast, depends on the weight of the charge of the internal blast and the blasting index I_b , which for clays fluctuates within the limits of 100-1400 $\text{dm}^3 \text{ kg}$.

However, in addition to the relationships obtained in the case of explosion of camuflet charges of low weight, it proves to be necessary to introduce the correctional factor k:

$$V = k I_{bp} \sum Q_i \quad (8.30)$$

where $\sum Q_i$ is the total weight of the shots and basic charges of explosive in kg.

Knowing the weight of explosive charges and measuring the actual volumes of tanks obtained V_f it is possible to determine the correctional factor:

$$k = V_f / Q I_{bp} \quad (8.31)$$

For the conditions of exploding camuflet charges the correctional factor $k = 0.8$, that is the volume obtained was 20% lower than the calculated volume. With an increase in the size of the charge the value of the factor k will decrease.

A tank was opened in order to determine the suitability of the given method of constructing storage areas. For this purpose a test hole was sunk to the side of it. Investigation showed that the compaction of the soil was approximately equal to three radii of the cavity formed. Sections of the surface of individual tanks in non-uniform loams had insignificant surface cracking. The depth of the cracks reached 12-15 cm.

As a result of the compression of the rock during explosion structural-textural changes take place, the dispersion and other properties of the clays and loams also change. These changes and their nature depend on the petrographic composition, genesis, age, and depth of occurrence of the working layer. At the same time it was established that the mineralogical composition of the rock did not change under the influence of the internal explosion.

As a result of the action of the shock wave on the soil its moisture, density, and strength characteristics (adhesion, internal angle of repose, axial compression strength) changes. The unit weight of the soil increases by 10 to 15%, and the porosity decreases by 15-20%, as a consequence of which the compressive strength of the rock increases by 2-3 times and adhesion increases by 4-5 times.

It is most expedient and economical to use pyroxilin powder byproducts of different types for blasting. They sink well and detonate in water, are simple and safe to handle. On intermediate charges consisting of 3-5% of the weight of the main charge is used for the detonation of pyroxilin powders. The ultimate choice of explosive depends on the physicommechanical properties of the clays and loams.

Charges are detonated electrically with the use of water-resistant electric detonators of instantaneous and short delay action.

Fig. 8.28 shows a tank shape recorded by means of remote photography. Photography is performed for several cross sections.

If because of unfavorable geological conditions of water entering, part of a tank has collapsed or there has been a partial crumbling of the vault, it is necessary to reinforce it again by firing or other artificial methods.

For depot construction of tanks by the internal explosion method it is necessary first of all to determine the minimum distances between individual tanks. In depot construction not only the shape and depth of a tank, and the physicommechanical properties of the strengthened ground around the cavity, but also the seismic effect of explosions during the formation of subsequent tanks influence the stability of an underground tank.

In constructing a tank together with finished tanks expansion

waves arise in the latter, which may lead to their destruction.

Tanks formed by internal explosions may be made close together if conditions are created for the extinction of counterblast (shock) waves and for maintaining a high internal counter-pressure of explosion products in all tanks of the group being blasted.

This neutralizes the action of attenuated secondary expansion shock waves from the moving tank-blast product boundary surface on the contour of the blast tanks.

The formation time of a tank depends on the physicomechanical properties of the medium and the weight of the explosive charge. For example, for the formation of a small tank (100 m^3) in loam with a trinitrotolene charge weighing 450 kg, it amounts to 60-80 ms.

The intervals between explosions during depot construction

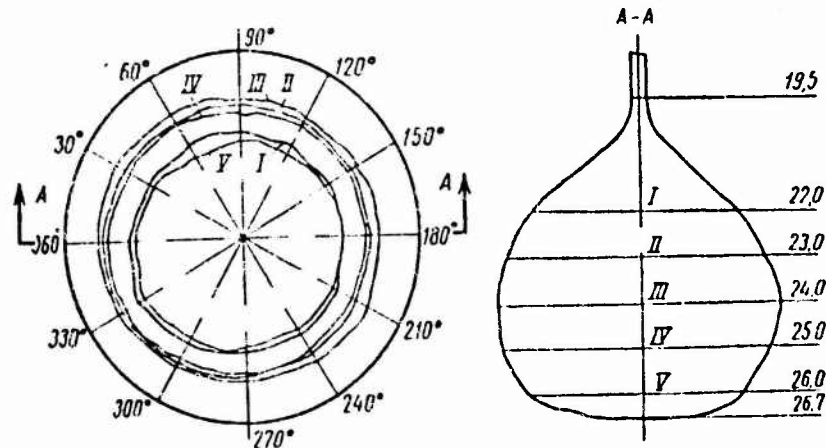

Fig. 8.28. Tank shape recorded by means of photography with a special remote camera.

differ greatly, but in sum they should be less than the formation time of an individual tank. In this case the maximum closeness of tanks is achieved with their stability and reliability during operation being observed.

A necessary and sufficient condition for the formation of stable underground tanks with the above-mentioned blasting conditions is

$$t_{\text{tank}} \geq t_{\text{del}} \quad (8.32)$$

where t_{tank} is the formation time of an underground tank in ms; t_{del} is the period (delay) between explosion of the basic explosive charges in ms.

If this condition is fulfilled in the process of the simultaneous formation of a group of tanks great internal counter-pressure of the blast products will be maintained inside all expanding cavities, which will counter the collapse of the cavities from the action of the blast waves of adjacent internal explosions. Consequently, with such a system of tank blasting at a depth of 20 m it is possible to place the tanks even at a distance equal to their depth. In such case the length of communication lines is shortened and the area required for constructing the depot itself is reduced.

Individual tanks 100-150 m³ in volume are constructed in two stages, the construction process proper--tank formation by blasting, occupying fractions of a second. Most of the time is taken up in drilling and charging the bore holes. Even shorter construction times may be achieved by the simultaneous blasting of a group of tanks. In this case the whole depot is constructed in fractions of a second.

Blast tanks are cheaper than steel tanks. Their efficiency greatly depends on their depth, the cost operation, and on the service life.

No metal is required for the tanks themselves, steel pipes are necessary only for casing the bore holes and for the pipe columns for supplying and removing the oil products stored. The metal economy in blast tanks is significant in comparison with steel tanks. The technical-economic indicators of blast storage areas up to 400 m³ in volume are given in Table 8.3.

TABLE 8.3

Product Stored	Cost of 1 m ³ capacity, rubles		Metal Consumption per 1 m ³ of capacity, kg.	
	Steel	Blast	Steel	Blast
Oil Product	15	4-10	36	7-10
Liquefied Gas	60-120	15	112-350	10-15

The temperature conditions of storing oil products and liquefied gases in underground blast tanks are more favorable than in above ground tanks, losses from "small breathings" are being eliminated.

Chapter Nine

REINFORCED CONCRETE TANKS

§ 1. Reinforced Concrete Tanks for Storing Oil

In comparison with steel tanks reinforced concrete tanks have a number of advantages and disadvantages which must be considered in constructing tank forms. The positive qualities of reinforced concrete tanks are:

a - the significant reduction in the consumption of sheet steel; in reinforced concrete tanks with a capacity of 10,000 - 30,000 m³ the steel consumption is 5-6 kg per 1 m³ of volume, and in steel tanks of the same capacity the steel consumption is 15-18 kg per 1 m³ of volume;

b - reinforced concrete tanks are not subject to corrosion and therefore may be sunk in the ground, which reduces fire danger and leads to a significant reduction in the area required for constructing a tank farm;

c - being sunk in the ground reinforced concrete tanks are not subject to the effect of daily temperature fluctuations, which reduces losses of the product from evaporation;

d - since reinforced concrete (with the use of special cements) is not subject to damage from the action of petroleum products and vapors, which are aggressive with respect to steel, concrete tanks require practically no maintenance when in use.

The negative qualities of such tanks are:

a - the high cost in comparison with steel tanks; on the average buried reinforced concrete tanks of 10,000 m³ capacity are more expensive than above ground steel tanks by 40-50%;

thanks to the reduction in the building area and the shorter communication lines (pipe lines and roads) in comparing the cost of tanks in tank farms the difference in cost is reduced 20-25%;

b - the significantly greater labor consumption of installation operations; the labor consumption in constructing reinforced concrete tanks (in comparison with steel tanks) is increased because of the presence of wet processes (pouring the bottom, sealing the joints between prefabricated structural elements), the significant amount of prefabricated structural elements, requiring assembly; the labor consumption in constructing reinforced concrete tanks is increased if the work is performed in winter time since it is necessary to use special measures for heating, winter shelters, etc. ;

c - the necessity of taking special measures to provide that the covering be gas-tight in case of storing petroleum products with a high vapor pressure (light petroleum products, crude oil);

d - special requirements for the area in which it is proposed that buried tanks be constructed; the soils here must be uniform, dense, and not subject to frost heaving to eliminate non-uniform settling of the tanks and the raising of ground water, the level of which (taking account of seasonal and long term fluctuations), must be 1-2 m below the proposed bottom level of the tanks.

Considering the enumerated qualities of reinforced concrete tanks for storing oil, at the present time basically, cylindrical buried tanks of large capacity with a water screen on the covering are constructed. Such tanks are completely (wall, covering and bottom) subjected to preliminary stressing.

Both cylindrical and rectangular buried tanks without an airtight covering are used for storing heavy oils. To reduce losses in heating the product the cover is provided with heat insulation (covered with dirt).

Reinforced concrete tanks basically are constructed in large tank parks.

§ 2. Classification of Reinforced Concrete Tanks and Basic Concepts in Designing them

Reinforced concrete tanks are classified according to the following criteria:

a - according to the type of product to be stored: tanks for light oils, tanks for petroleum, tanks for heavy oils (residual oil, furnace fuel oil, etc.);

b - according to the structural shape: cylindrical, rectangular, trench, lens, etc.;

c - according to the position with respect to the surface of the ground: above ground, buried.

Reinforced concrete tanks also are constructed in particularly complex conditions, for example, in the presence of rising ground water, in seismic regions, and in permafrost regions.

The technical-economic indicators for reinforced concrete tanks are given in Table 9.1.

Table 9.1

Tanks	Capacity, m ³	Steel consumption per m ³ of capacity, kg		Consumption of concrete per m ³ capacity, m ³
		For light oils	For heavy oils and crude oil	
Cylindrical Buried	5 000	12,8	6,14	0,074
	10 000	11,9	5,45	0,060
	20 000	11,0	5,00	0,056
	30 000	—	4,50	0,055
Rectangular Buried	5 000	14,5	7,36	0,080
	10 000	12,2	6,00	0,069
	20 000	11,0	5,50	0,065

The data in Table 9.1 show that the specific consumption of the basic materials used in constructing tanks decreases with an increase in tank capacity. The area required for constructing a tank farm also decreases with an increase in tank capacity.

The technical-economic indicators of a tank farm with a total capacity of 240,000 m³ with tanks of different capacity are shown in table 9.2, from which it is obvious that the cost of a farm using tanks with capacities of 20,000 and 30,000 m³ is less than the cost of a farm made up of tanks of 10,000 m³ capacity. Thus, for light oils the cost is reduced from 12 to 25%, for dark oils - from 14 to 30%. The area required for constructing the farm is reduced correspondingly: with cylindrical tanks by 15-38%, with rectangular tanks by 20-45%.

In addition, comparative calculations show:

a - the consumption of metal is reduced with the use of tanks of 20,000 and 30,000 m³ capacity in comparison with tanks of 10,000 m³ capacity: in tanks for light oil, from 10 to 30% and in tanks for heavy oils from 6 to 25%; for tanks of rectangular shape the metal consumption is 10% more than for cylindrical ones;

b - the cost of tank farms made up of cylindrical tanks on the average is 10% lower than the cost of farms of rectangular tanks.

The data presented show that it is necessary to try to use large capacity tanks.

§ 3. Standardization of the Construction of Reinforced Concrete Tanks. Standard Tank Series

Reinforced concrete storage installations, including tanks, are some of the most common installations in all branches of the economy.

Table 9.2

Indicators	In equipping a farm with tanks of the following capacities in m ³					
	10,000		20,000		30,000	
	For crude oil	For light oils	For crude oil	For light oils	For crude oil	For light oils
Area of farm, hectares.....	11.40	11.40	9.55	9.55	7.00	7.00
%.....	100	100	84	84	61	61
Extent of production pipelines, km.....	547	547	3.83	3.83	1.97	1.97
%.....	100	100	70	70	36	36
Extent of fire prevention pipeline, km.	2.21	2.21	1.75	1.75	1.49	1.49
%.....	100	100	79	79	67	67
Automobile roads, m ²	11.37	11.37	9.40	9.40	7.70	7.70
%.....	100	100	83	83	68	68
Cost of farm, million rubles.....	2.4620	2.6521	2.2514	2.2952	1.7279	1.8426
%.....	100	100	92	86	70	70
Cost of farm per m ³ of useful capacity rubles.....	10.2	11.0	9.4	9.6	7.2	7.6
%.....	100	100	92	86	70	70

Table 9.3

Type of liquid stored	Tank capacity, m ³													
	50	100	250	500	1000	2000	3000	5000	6000	10,000	20,000	30,000	40,000	
Water	+	+	+	+	+	+	+		+					
Residual Oil					+		+	+		+	+			
Crude Oil					+		+	+		+	+	+	+	
							Rectangular							
Water	+	+	+	+	+	+	+		+	+	+	+	+	
Residual Oil		+	+	+	+	+								

To eliminate seasonality, to reduce the time consumed at the construction site and to do away with costly forms, standard prefabricated factory built structures are used in building a very large number of storage facilities in our country. In the given case, the use of standard prefabricated structures is especially efficient, since reinforced concrete tanks are installed in large groups.

As a result of a great amount of work performed by a number of planning institutes, the following have been established: a standard capacity series of tanks for storing different liquids, the shapes of the tanks (cylindrical rectangular), their overall dimensions and maximum capacity (Tables 9.3 and 9.4).

As a result of the standardization of tank constructions it has been possible to reduce sharply the number of sizes of reinforced concrete structures and to make partial use of the standard constructions for commercial buildings, introduced in the All Union Catalogue (Table 9.5).

As is seen from Table 9.5, in spite of an overall reduction in sizes by almost two times, the range of tank capacities has been expanded significantly.

Table 9.4

Tank Capacity, m ³	Tank Dimensions (in m)			
	Cylindrical		Rectangular	
	Diameter	Height	Plane	Height
50	6	1.8	3×6	3.6
100	6	3.6	6×6	3.6
250	9	3.6	6×12	3.6
500	12	4.8	12×12	3.6
1 000	18	4.8	12×18	4.8
2 000	24	4.8	18×24	4.8
3 000	30	4.8	24×30	4.8
5 000	42	4.8	—	—
6 000	30	7.8	36×36	4.8
10 000	42	7.8	48×48	4.8
20 000	54	9.0	66×66	4.8
30 000	66	9.0	78×84	4.8
40 000	78	9.0	90×96	4.8

The standardization of prefabricated reinforced concrete tank constructions make it possible not only to increase the degree of industrialization of construction, but also to lower their cost.

Table 9.5

Tank Shape	Before standardization		After standardization	
	Capacity, m ³	Number of sizes	Capacity, m ³	Number of sizes
Cylindrical Rectangular	50-10,000	45	50-40,000	21
	3000-20,000	16	50-40,000	12
In all	---	61	---	33*

* Nine of these in the catalogue (series II 22, 23 and 24).

§ 4. Cylindrical Reinforced Concrete Tank Structures.

A cylindrical tank structure includes a cover, a wall, a bottom and columns supporting the cover. Before 1956-1957 reinforced concrete tanks mainly were made from monolithic reinforced concrete; their structure consisted of a flat bottom 10-15cm thick, walls and a cover, interconnected monolithically. Tank covers were designed in beamless or cupola types.

Cylindrical tanks of monolithic reinforced concrete (Fig. 9.1) without preliminary stressing of the wall are not crack resistant, and are used for storing crude oil and petroleum products only in the case of small volumes (up to 1,000 m³). The basic design of cylindrical reinforced concrete tanks, used for all standard designs of the standard series, is a combined design, where the bottom is made of monolithic reinforced concrete, and the walls, cover and columns are made of prefabricated reinforced concrete (Fig. 9.2).

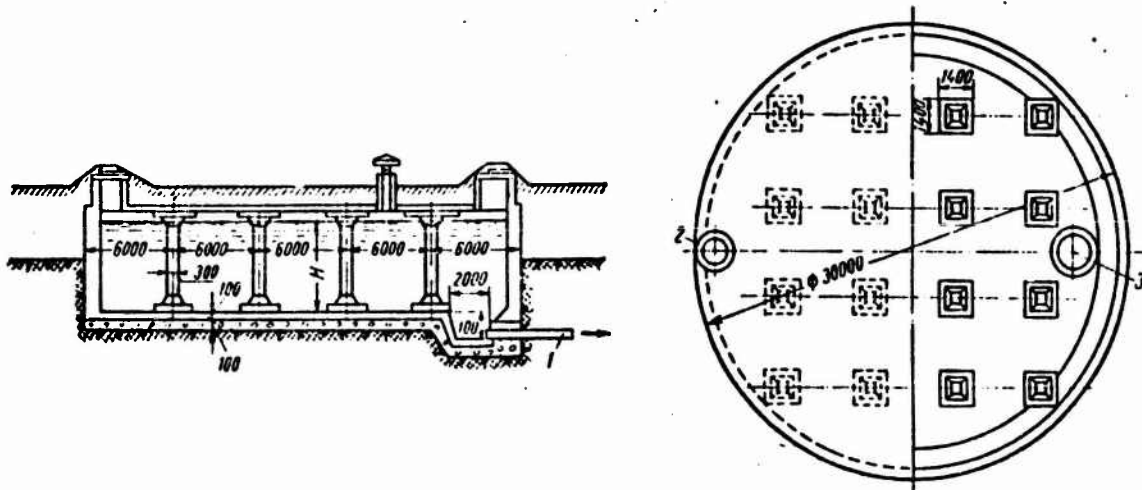

Fig. 9.1. Cylindrical tank of monolithic reinforced concrete.
1- sludge pipe; 2- manhole; 3- pit

Let us examine the elements of this design in more detail.

The tank bottom is made of monolithic reinforced concrete. The practice of using prefabricated reinforced concrete plates for constructing tank bottoms did not produce positive results. In the case of a large bottom area (up 3,000-4,000 m²) the length of the seams between the plates becomes great and, in addition, the natural base must be laid out very precisely to make the bottom horizontal. Therefore it was necessary to stop making tank bottoms out of prefabricated plates. In large capacity tanks (20,000-40,000 m³) the bottom area reaches 3,000-4,000 m², therefore to eliminate the danger of the appearance of settling cracks during pouring the working seams are left open, and are joined together later. Experience in tank construction has shown that the most reliable monolithic reinforced concrete bottom design is one where preliminary stressing (compression)

is imparted to the bottom after the seams are made monolithic. In this case, all seams are compressed and may be unreinforced, which allows the seams to be made in a form and to be treated well before being made monolithic.

A prestressed bottom (with a stress of 20-30 kg/cm²) makes it possible to reduce the consumption of reinforcement sharply.

A bottom is prestressed by winding a high strength wire onto the tank wall in the area where the bottom connects with the wall.

Unstressed bottoms are used for tanks for storing heavy oils. In this case, the bottom is reinforced with welding screens.

The wall of a prefabricated cylindrical reinforced concrete tank consists of vertical panels, the height of which is equal to the height of the tank. Wall panels are standardized. At the present time, three sizes are used for the entire series of tanks, one size for the group of tanks of 1,000-3,000 m³ capacity, one for the 5,000-10,000 m³ capacity tanks and one for the tanks of more than 10,000 m³ capacity.

A list of the wall panels and their overall dimensions are given in Table 9.6.

The thickness of the wall panels for tanks of up to 10,000 m³ capacity (inclusively) is assumed to be constant along the height of the panels and variable for tanks of more than 10,000 m³ capacity.

Wall panels are made of types 300-400 concrete in steel forms in plants manufacturing reinforced concrete articles.

Wall panel reinforcement consists of welded standard screens and vertical reinforcement, calculated for the effect of the

bending moments in the vertical plane. In tanks of 10,000 m³ capacity and more, the vertical reinforcement is prestressed to provide crack resistance. The heaviest wall panels weigh 10 tons.

The covers of cylindrical tanks are either of the cupola type or flat-beam. From 0.056 to 0.088 m³ of concrete and from 5.6 to 10.5 kg of steel is used per m² of a cupola cover for a 10,000 m³ capacity tank, and from 0.15 to 0.20 m³ of reinforced concrete and from 13.6 to 16.5 kg of steel is used per 1 m² of a flat cover for the same tank.

Cupola covers are used in case of constructing monolithic reinforced concrete tanks. In spite of their economy they have significant disadvantages.

a - in the prefabricated version, it is difficult to obtain standardization for all tank sizes used, and it is complicated and laborious to make;

b - tanks with a cupola cover have a large unused area (gas space); in the case of buried tanks warming the cover with the soil is complicated.

Different requirements are imposed on a tank cover depending on the type of petroleum product to be stored. In correspondence with these requirements, two types of covers were distinguished.

Covers of the first type must satisfy the conditions of hardness, crack resistance, water and gas tightness, and covers of the second type - only the conditions of hardness and water tightness.

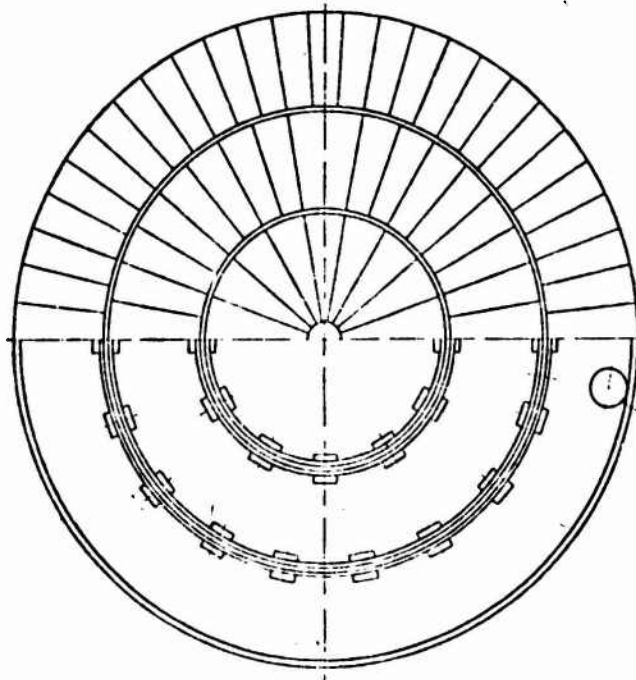
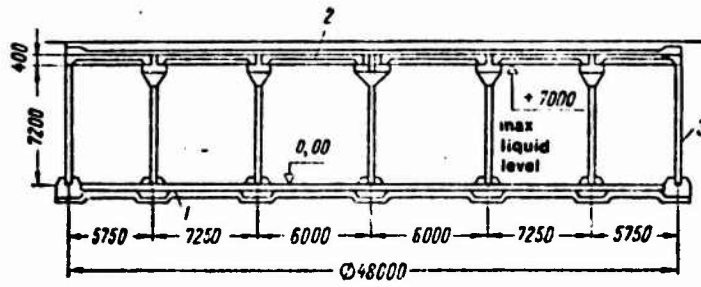

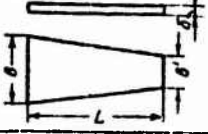
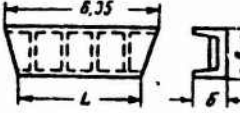
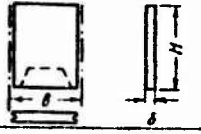
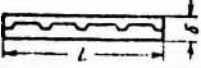
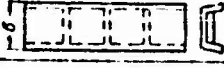
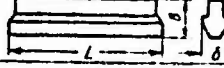
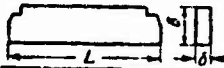
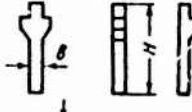



Table 9.6

No. P/P	Sketch	Nominal dimensions, mm				Weight of unit, T
		H (L)	v	b	R	
1		3.60	1.57	0.12	3.0	1.5
2		4.80	1.57	0.12	6.0	2.0
3		4.80	1.57	0.14	9.0	2.4
4		4.80	2.35	0.18	15.0	2.9
5		5.20	1.57	0.16	15.0	3.0
6		8.60	2.35	0.20	15.0	9.1
7		9.60	2.35	0.16 - 0.26	30.0	10.5
8		3.60	3.00	0.18	—	5.1
9		3.60	2.00	0.18	—	2.9
10		4.80	3.00	0.20	—	7.3
11		7.20	0.40	—	—	2.4
12		4.30	0.40	—	—	1.5
13		8.16	0.40	—	—	2.7
14		0.50	1.50	—	—	1.4
15		0.60	1.20	—	—	1.4

Table 9.6 (cont'd)

No. P/P	Sketch	Nominal dimensions, mm				Weight of unit, T
		H (L)	V	b	R	
16		6.70	3.06	0.56	3.35	6.0
17		5.90	0.82-2.90	0.12	—	3.3
18		5.90	1.73-2.97	0.12	—	4.2
19		5.90	2.12-3.00	0.12	—	4.6
20		5.90	2.45-3.00	0.12	—	4.8
21		5.70	0.90	0.60	—	2.7
22		6.00	0.90	0.60	—	2.8
23		4.80	3.00	0.14	—	4.4
24		5.55	1.485	0.40	—	2.2
25		5.95	1.485	0.40	—	2.4
26		5.48	0.80	0.65	—	4.1
27		5.28	0.80	0.3	—	3.1
28		5.48	0.80	0.3	—	3.2
29		4.80	0.40	—	—	2.1
30		4.80	0.40	—	—	2.3
31		3.60	0.40	—	—	1.6
32		3.60	0.40	—	—	1.8
33		5.12	0.40	—	—	2.4

Note. Units 1-23 are of individual manufacture, the rest - standard series; 24-II 24-1, 25-II 24-2, 26-II 23-1, 27, 28-II 23-3, 29-33-II 22-23, II 23-3.

The following structural solutions may be used for a cover of the first type.

A cover with a quarter screen (Fig. 9.3), consisting of a system of straight beams, resting on columns, arranged in concentric circles. Radial ribless prestressed plates (10-12 cm thick), spanning 6 m, are mounted on the beams.

It is easy to assemble straight beams, but they must be 90 cm wide to allow for the installation of radial plates. The beams are U-shaped in cross-section (Fig. 9.4) and are made in factories out of type 300-400 concrete with prestressed reinforcement. The beams weigh 5-6 T.

The beams are set on column brackets and welded to them with insertion parts. Before installing the cover plates, the upper surface of the beams is covered with a thin layer of clay, treated with crude oil or residual oil, which makes it possible to slide the cover plates along the beams while prestressing the entire cover disc.

Having installed all cover plates and having closed the joints, the entire cover disc is prestressed by means of winding a high strength wire onto the tank wall at the point where it contacts the cover. A fully stressed highly crack resistant cover (including all seams) is obtained onto which a 15 cm layer of water is poured. All hatches in which equipment is installed are sealed especially carefully in the cover. A general view of a finished cover is shown in Fig. 9.5. Water penetrating into the concrete to a depth of 20-40 mm makes it gas-tight.

The 30,000 m³ capacity tanks on the "Druzhba" oil pipe line and a number of other installations have covers of this construction and have proved to be completely adequate.

In regions with intensive evaporation, it is necessary to maintain a water screen on the cover by adding water with an ordinary fire hose.

The first type of covers also includes covers of ribbed radial plates which are sealed by means of gluing a synthetic or rubber fabric film around them. The film is first glued or vulcanized and securely and hermetically connected with the cover and tank wall with a special glue. The places where hatches and equipment manholes are installed are sealed especially carefully. In this case, a layer of dirt 30-40 cm deep is spread on the cover. At the present time experimental models of tank covers with synthetic film gas insulation are being constructed.

For covers of the second type (in tanks for heavy oils), when it is not necessary to provide gas-tightness, ribbed radial plates are used (see Fig. 9.2), replacing the synthetic film with an ordinary three layer rubberoid mat.

The joints between the prefabricated wall of cylindrical tanks and the cover and bottom depend on the construction of the cover and bottom and may be of two types. The first type includes joints between a wall and a prestressed cover and bottom (Fig. 9.6 and 9.7).

The basic requirements imposed on these units are the following: The capability of transmitting the force from winding prestressed reinforcement to the wall, cover and bottom; reliable sealing of joints.

The first requirement is satisfied by attaching the flat plates of the cover to the wall panel brackets, and the second by making the joints monolithic. The bracket is located so that it is possible to place the necessary number of turns of the stressed reinforcement (up to 500 turns) in the upper part of the wall panel, the coils being located symmetrically relative to the middle

surface of the cover, so that an additional bending moment in the cover from the horizontal resultant force is not created due to the twisting of the reinforcement.

The joints are made monolithic before twisting the reinforcement, which provides rigidity and crack resistance of the unit.

As is seen from Fig. 9.7, the wall is connected with the bottom by means of setting the wall panels on base plates which lie on a layer of sand (5 cm). By making the thickened section of the bottom of the monolithic concrete, a compressive force is transmitted to the tank bottom from the reinforcement wound on the wall, and the unit is sealed.

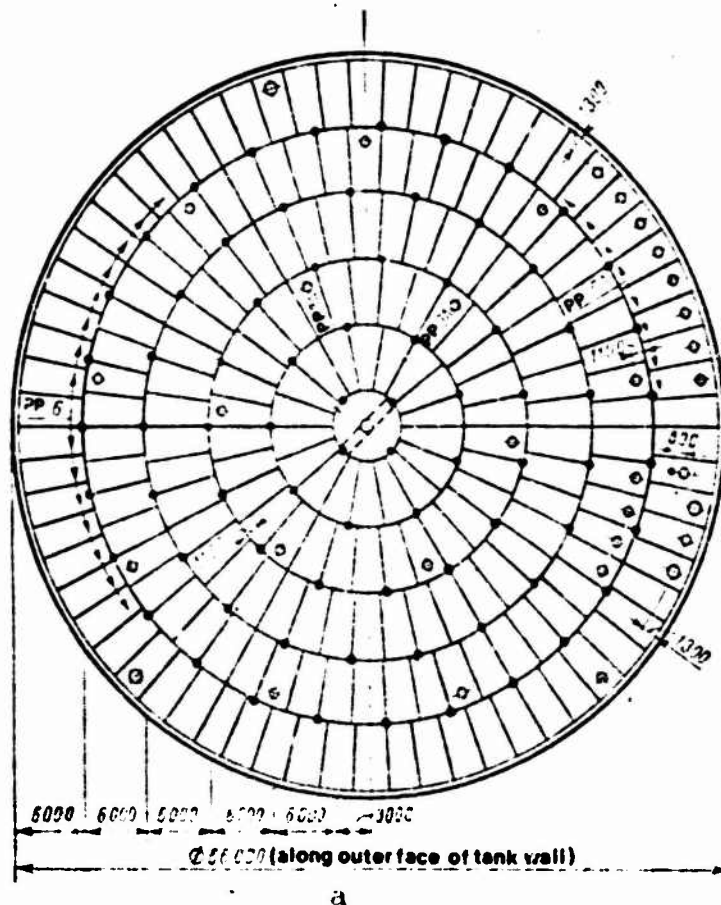

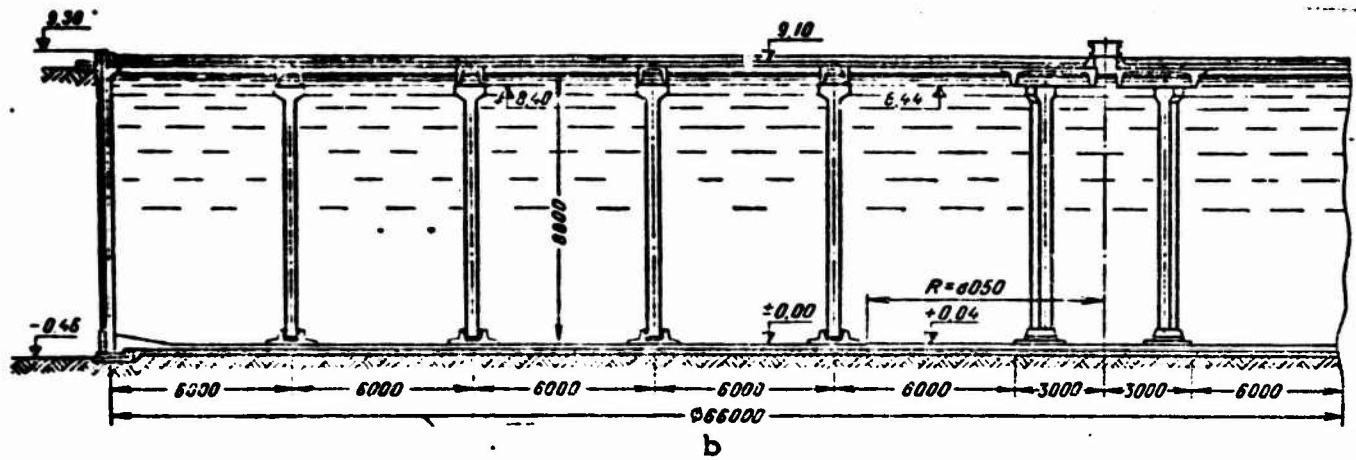
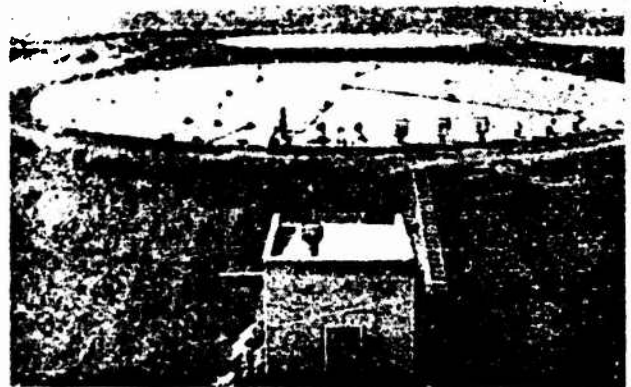

Fig. 9.3. 30,000 m³ capacity tank with a water screen on the cover.
a- layout of the plates of the stressed cover; b- cross-section.



+ Fig. 9.4. U-shaped beams of a stressed tank cover.

Fig. 9.5. General view of a tank cover with a water screen



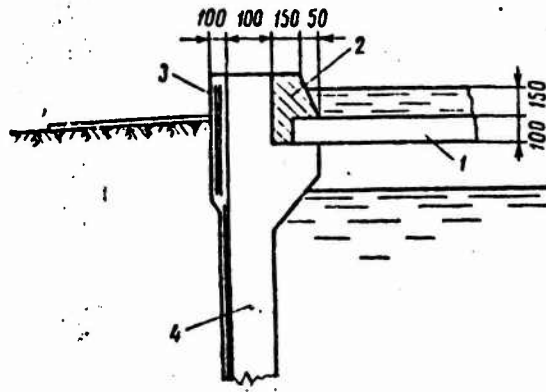

Fig. 9.6. Connection between a cylindrical tank wall and a prestressed cover.

1- cover plates and water screen; 2- monolithic concrete; 3- twisted stressed reinforcement; 4- tank wall

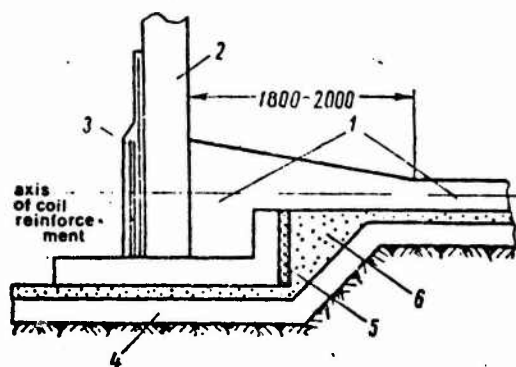

Fig. 9.7. Connection between a cylindrical tank wall and a prestressed bottom.

1- tank bottom; 2- tank wall; 3- twisted stressed reinforcement; 4- prepared bed; 5- flexible gasket; 6- sand
Note the fallout access of coil reinforcement

The thickened part is poured after pouring the bottom, setting the wall panels, and filling the seams between them. The reinforcement wound on the wall transmits compressive force to the bottom

and reliably seals the contact surface between the tank wall and the thickened part of the bottom.

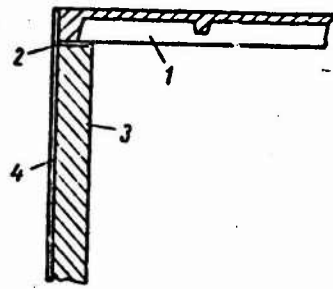

Fig. 9.8. Connection between a cylindrical tank wall and an unstressed cover.

1- cover plates; 2- layer of cement solution; 3- tank wall; 4- gunite-plaster.

A layer of sand (5 cm) is spread under the base plate and the bottom itself to make it possible for the bottom to deform when it is squeezed. Usually a compression force of 30 kg/cm^2 is assumed during the squeezing of the bottom. Tests of the given bottom design have shown that its prestressing drops toward the center by no more than 10-12%. A sliding layer of clay impregnated with oil residues or residual oil is spread under the column bottoms so that the columns do not block deformation of the bottom when it is squeezed.

The second type also includes joint constructions in which it is not necessary to seal the joint between the wall and the cover, and the bottom is not prestressed (Fig. 9.8 and 9.9).

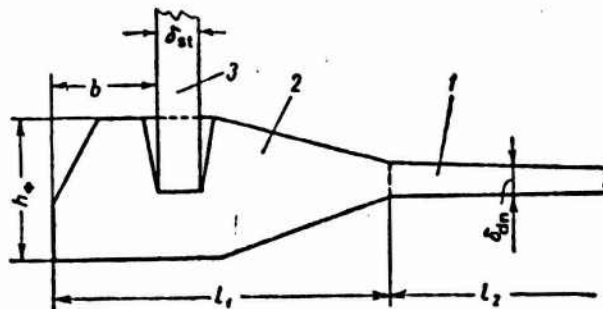

Fig. 9.9. Joint between a tank wall and an unstressed bottom. 1- bottom plate; 2- base plate; 3- tank wall.

Radially-ribbed cover plates are used in this case. They lie free with their ribs on the upper ends of the wall panels. The space between plate and wall is sealed with concrete only to prevent dirt and moisture from falling into the tank.

The walls are joined with the bottom by means of inserting the wall panels into a groove, which is made in the monolithic concrete when the bottom is poured. The groove must be accurately spaced and it must be no less than 10 cm wider than the thickness of a wall panel.

The groove is poured after the joints between the wall panels are filled and the stressed reinforcement is laid on the wall, otherwise the wall will not deform when the stressed reinforcement is squeezed, which will produce a significant bending moment at the place where the wall connects with the bottom. To reduce friction between the end of the tank wall and the bottom surface of the groove two layers of rubberoid are laid on it or the bottom of the groove is covered with a cement solution. After the wall panels are installed, it is necessary to prevent debris and concrete from getting into the groove; therefore the groove is temporarily filled with sand or sawdust.

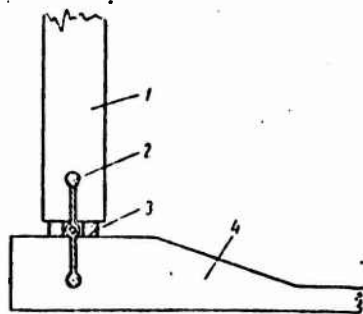

Fig. 9.10. Tank wall connected with bottom by means of a rubber belting strip.

1- tank wall; 2- shaped strip; 3- flat rubber strips; 4- tank bottom

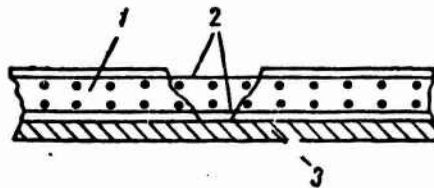

Fig. 9.11. Seams in a tank bottom

1- bottom; 2- reinforcement grids; 3- foundation

In foreign countries, where reinforced concrete tanks are made out of monolithic reinforced concrete, the wall is connected with the bottom using concrete-resistant rubber gaskets and a special shaped rubber strip (Fig. 9.10). The gaskets make it possible for the wall to deform during prestressing, and the strip seals the unit. The joints in the bottoms, walls and covers are filled with a concrete having a fine aggregate, whereby the grade of concrete used must be no lower than the grade of the concrete of the structures to be connected.

The construction of the seams in the case of an unstressed bottom is shown in Fig. 9.11.

The seams between wall panels are made straight (20 cm wide) and contain the protruding ends of the reinforcement (Fig. 9.12). Before pouring, the protruding ends are welded. The diameter of the ends is 8-10 mm, and the distance between them is 70-100 cm in height. The ends are used for attaching the form when the joint is filled. To keep the product from leaking the wire twists which serve to attach the form must not penetrate the entire thickness of the joint.

The joints between cover plates are not reinforced, are filled with grade 300-400 concrete and are compacted carefully by means of vibration.

Cylindrical tank walls are prestressed so that the resultant stress in the wall is compressive ($8-10 \text{ kg/cm}^2$) both while the product is being poured in and for the case of an unfilled tank.

Different methods are used for prestressing cylindrical tanks, but the most common method is that of twisting a high strength wire ($d=5 \text{ mm}$). The wire is twisted with a stress of $0.65R_a$, where R_a is the ultimate tensile strength of the wire ($17,000-20,000 \text{ kg/cm}$). The twist spacing is determined by calculation. The twisted reinforcement is protected from corrosion with a 30 mm layer of gunite-plaster.

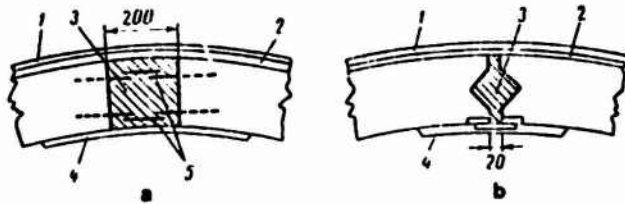

Fig. 9.12. Joints between wall panels

a- straight; b- keyway;

1- outer gunite; 2- twisted reinforcement; 3- joint concrete;

4- inner gunite; 5- ends to be welded.

§ 5. Rectangular Reinforced Concrete Tank Constructions

The standard series of rectangular tanks provides for capacities of up to $40,000 \text{ m}^3$, which corresponds to a bottom area of $8,000 \text{ m}^2$. In order to eliminate the danger of the appearance of cracks in the bottom, due to thermal effects, deformation seams are placed every 30-40m. The construction of a deformation seam is quite complex and requires the use of stainless sheet steel. In addition, a deformation seam may be the point of appearance of product leakage.

Considering that stretching stresses in a tank appear only while it is cooling, danger of cracks appearing will occur when the tank is empty and not warmed by the round. Thus, if unpoured strips (not interrupting the reinforcement) are left every 30-40 m when the bottom is poured, and they are poured with the lowest possible temperature for pouring (-5°C) or with electric heating (where $t \approx 10-15^\circ\text{C}$), then cracks will not appear when the tank is used. This method of pouring is very appropriate for the construction of a number of types of structures and is used in making standard projects.

The walls of rectangular tanks (3.6 and 4.8m in height) are constructed of standard panels (see table 9.6) according to two designs: 1) in the form of a bracket, made in the bottom (in the case of heights of up to 3.7m), and 2) in the form of an elastic insert in the bottom and a hinged support in the cover surface. In the case of the bracket solution wall panels of grade 300 concrete are prestressed. On the side faces of the wall panels there are projecting ends ($d = 8-10\text{mm}$), which are welded during assembly.

At the present time the points of intersection of longitudinal and transverse walls of rectangular tanks are connected by

three methods (fig. 9.13): 1) in the form of a monolithic angle piece, 2) with a special prefabricated angle panel and 3) in the form of the intersection of straight panels with the angle joint cemented and insulated with a synthetic film or fiberglass. The first method is used most widely.

Standard prefabricated catalog constructions of covers for commercial buildings (series II 22, 23 and 24) are used for constructing rectangular tank covers.

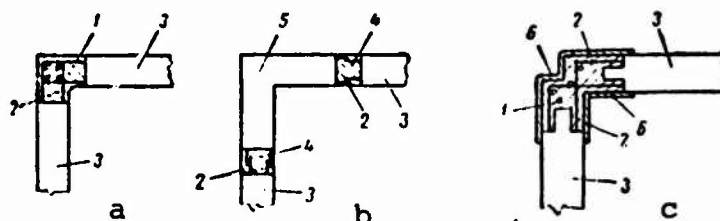

Fig. 9.13. Angular joints of rectangular tank walls.

a- monolithic angle piece; b- angle panel; c- plastic angle hinge.

1- monolithic concrete; 2- projecting ends of reinforcement; 3- standard wall panels; 4- butt joint of panels; 5- nonstandard angle panel; 6- hydro-insulation mastic, reinforced with fiberglass or rubber strip.

Considering the great load on the cover (the weight of the dirt cover, snow and assembly loads), standard designs used for multi-stage commercial buildings are used for its construction. As is mentioned above, in rectangular tanks a wall 4.9 m high must have a support in the plane of the cover. In this case the reaction which arises in the joint between the wall and the cover from hydrostatic loading or from ground pressure, must be transmitted through the structure of the cover, which is achieved by rigid connection of the cover beams with the wall by means of welding

through insertion pieces. In walls not abutting beams, connection with the cover may be made through the cover plates. In order to create a rigid connection between the beams of the cover and the walls the panels of the latter have brackets widenings on top, which operate as fastening beams on the sections between the joints (see Table 6.6).

The column grid of rectangular tanks is taken as 6x6m, and the columns and under columns are standard according to series II 22, 23 and 24.

The joints between wall panels of rectangular tanks and cover plates are made monolithic the same as joints in cylindrical tanks.

In view of the fact that the bottoms of rectangular tanks are not prestressed, the walls are joined with the bottom in a groove.

§ 6. Designs of Trench Reinforced Concrete Tanks

Rectangular tanks, the greater part of which consists of an excavation in the ground (Fig. 9.14), are called trench tanks. The bottom of a trench tank, as a rule, is trough-shaped and 3-4 m deep. The slope of the slanted parts of the bottom depends on the nature of the soil (around 1:2).

The walls of trench tanks are 1-2 m high and may be made both of reinforced concrete panels, and of concrete blocks. The covers do not have intermediate supports. Ordinary reinforced covers for commercial buildings (12-24 m span) are used for covering. Since the span of the carrying structures of the covers is great, the dirt cover is replaced with an efficient heater (foam concrete) and a hydro-insulation mat (3 layers of rubberoid) in order to reduce the load on them.

Trench tanks, as rectangular tanks, are insufficiently crack resistant and it is very difficult to provide them with a gas-tight cover. The technical-economic indicators of trench-type tanks are lower than in the case of rectangular tanks, and therefore they are used rarely at the present time. However, with the use of synthetic or rubber fabric films the trench shaped tank has proved to be very effective.

§ 7. Outlook for the Introduction of Synthetic Materials into Tank Construction

The use of synthetic or rubber tissue film materials in constructing reinforced concrete tanks may proceed along two paths. The first is when these materials may replace the reinforced concrete bottom, and possibly the cover, in order to eliminate the time consuming work of pouring and to improve the cover seal. Figure 9.15 shows examples of such constructions. It is necessary to note that the volume of the concrete of a tank bottom on the average amounts to 15% of the total concrete consumption, and the time consumed in pouring the bottom and filling the joints (considering the necessary time for the concrete to set) amounts to 30-40% of the time required for assembling the walls and cover.

As far as construction is concerned, the replacement of a reinforced concrete bottom by a synthetic film does not create difficulties and it is necessary only to obtain reliable glue joints (or vulcanization) of the film panels between one another and of the panels with the concrete.

The second method is to use insert pockets, which introduces radical structural changes in the construction of reinforced concrete tanks. The reinforced concrete elements of such tanks fulfill only hardness functions, and the problems connected with crack resistance and sealing are absent. As a result we obtain the possibility of significantly simplifying and reducing the cost of construction.

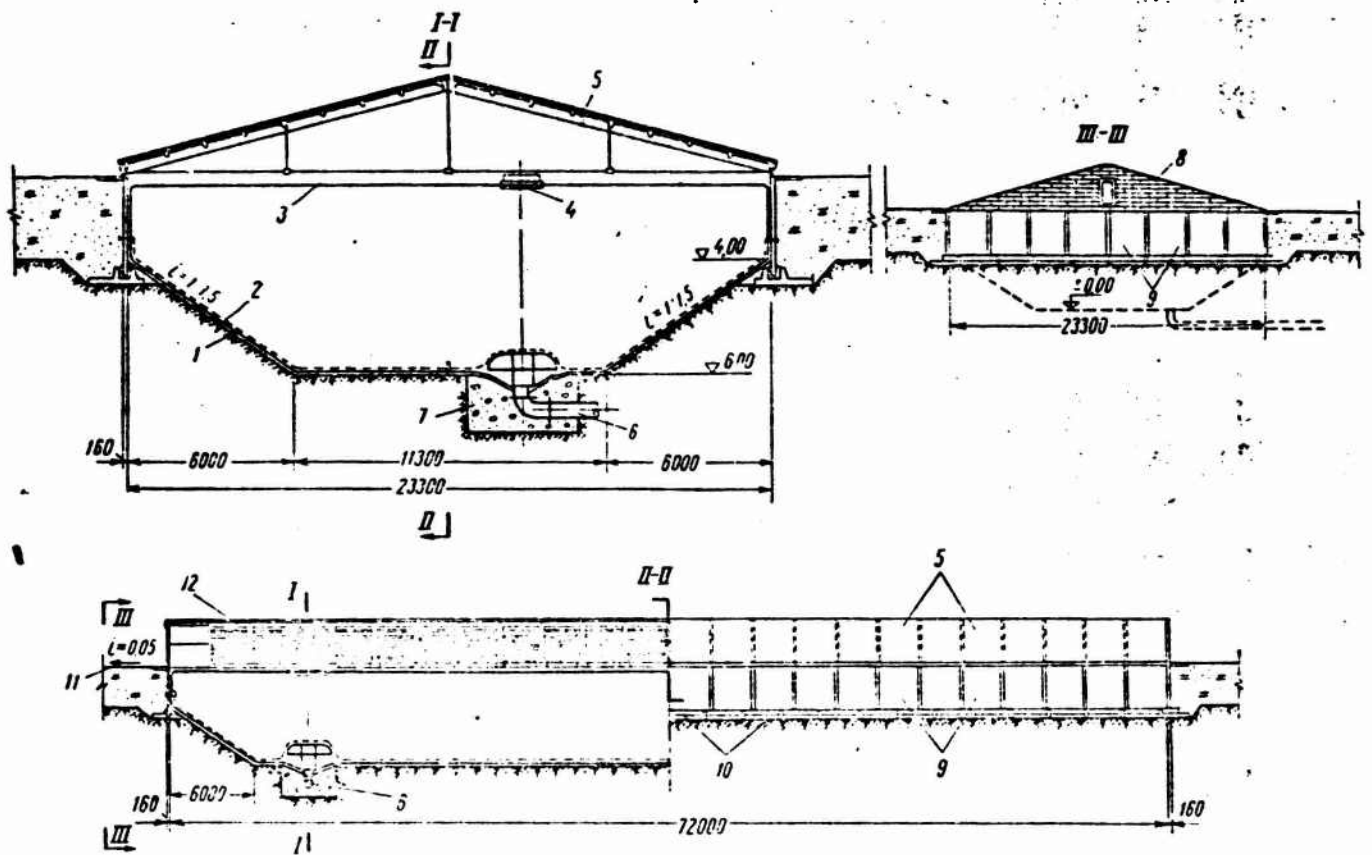

Fig. 9.14. 10,000 m³ capacity trench tank for light oils with a shell - insert

1- compacted soil; 2- position of the shell - insert in an empty tank (dotted line); 3- the same with a filled tank; 4- hatch in shell; 5- prefabricated reinforced concrete plates covered with a hydro-insulation mat; 6- receiving - distributing pipe; 7- grade 50 concrete; 8- slag concrete rocks; 9- reinforced concrete wall panels; 10- reinforced concrete foundation blocks; 11- asphalt waste; 12- removable reinforced concrete plates.

Also, a cylindrical tank shape will have no advantages over a trench shape, since both are simple to make.

The pocket inserts must be made in factory conditions and transported in folded form, and then lowered into the prepared tank structure. A pocket insert is insulated from the outside air, and upon being filled with the product its upper surface rises (floats) together with the product.

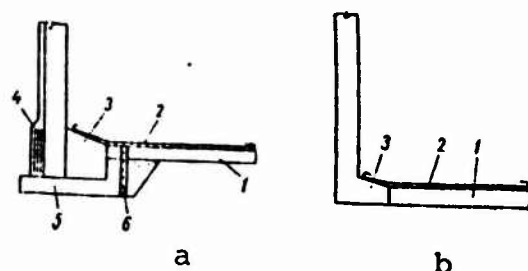

Fig. 9.15. Connection between tank wall panels and a synthetic film bottom.

a- with a stressed bottom; b- with an unstressed bottom;
1- concrete bottom or base; 2- synthetic or rubber fabric film;
3- glue joint; 4- stressed reinforcement; 5- prefabricated foundation plates; 6- elastic gasket.

With such a construction the bottom may be made in the form of a concrete base of lean concrete, and the walls of concrete blocks. The cover may be made similar to industrial shop roofs. Losses of product from evaporation are practically eliminated.

Chapter Ten

STATISTICAL CALCULATION OF REINFORCED CONCRETE TANKS.

§ 1. Loads Acting on Reinforced Concrete Tanks

Calculation of reinforced concrete tanks for crude oil and petroleum products is based on standard loads taking account of the load, accuracy of reinforcement stress, and overheating or overcooling factors presented in Tables 10.1, 10.2 and 10.3.

The value of the active side pressure q (in kg-f/m^2) of the soil on the tank walls is determined according to the formula

$$q = n\gamma_{gr}H \tan^2\left(45 - \frac{\phi}{2}\right), \quad (10.1)$$

where n is the load factor; γ_{gr} is the volume weight of the covering soil in kg/m^3 ; H is the distance from the ground grade are to the calculated level in m ; ϕ is the angle of internal friction. The volume weight of the product is taken according to the plan, but is not less than 900 kg/m^3 .

§. 2. Basic Assumptions for Calculating Cylindrical Prestressed Tanks

Tanks are calculated for the following cases of loading:

- a) the tank is filled with water, but is not covered with soil (tank testing);
- b) the tank is empty, but is covered with soil;
- c) the tank is filled partially or completely with the product and is covered with soil; in addition, the structures are subjected to non-uniform heating or cooling.

Load combinations are taken in accordance with construction norms and regulations II-A.11-62 "Loads and effects, design standards". The stresses in statically indeterminate tank constructions are determined according to the elastic stage.

Table 10.1

Loads and influences on reinforced concrete tank covers	Standard loads, kg/m ²	Load, tension accuracy, overheating and overcooling factors
Constant Loads and Influences		
Weight of cover proper	According to plan	1.1 (0.9)
Weight of heating layer:		
a) heat insulation layer	the same	1.2 (0.9)
b) soil	" "	1.3 (0.8)
Weight of hydro insulation and gas insulation	" "	1.2 (0.9)
Radial effect of stressed reinforcement (in prestressed covers)	----	1.1 (0.9)
Temporary Longterm Loads and Influences		
Weight of water layer on water filled flat covers	---	1.1 (0.9)
Weight of processing and fire protection equipment (at points of its location)	according to weight of equipment	1.2 (0.9)
Excess pressure in gas space	according to plan but not less than 200	In accordance with rated breathing reinforcement but no less than 1.1
Temperature effects	---	1.1 (0.9)
Short Term Loads and Influences		
Snow load	according to CN and R II-A.11-62	1.4
Assembly Load	according to plan	1.2
Vacuum in gas space	according to plan but not less than 100	In correspondence with rated breathing reinforcement but not less than 1.1
Special Loads and Influences		
Seismic influences	According to special technical specifications	

Table 10.2

Loads and influences on reinforced concrete tank walls	Standard loads, kg/m ²	Load, tension accuracy, over-heating or over-cooling factors
Constant Loads and Influences		
Loads from cover	According to Table 10.1	---
Active side pressure of ground on tank wall	According to formula 10.1	1.3 (0.8)
Radial effect of stressed ring reinforcement	According to plan	1.1 (0.9)
Temporary Long Term Loads and Influences		
Loads from cover	According to Table 10.1	---
Pressure of product	According to formula $p=H\gamma$	1.1
Vacuum in gas space	According to Table 10.1	1.0
Excess pressure in gas space	According to Table 10.1	---
Temperature effects	---	1.1 (0.9)
Ground water pressure	---	---
Short Term Loads and Influences		
Loads from cover	According to Table 10.1	---
Loads from assembly and transportation mechanisms, materials etc. on the sliding triangle of the soil cover	According to plan but not less than 1000	1.3 (0.8)
Water pressure (in testing tanks)	According to the formula $p=H\gamma$	1.0
Special Loads and Influences		
Seismic influences	According to special technical specifications	

Table 10.3

Loads and influences on reinforced concrete tank bottoms	Standard loads, kg/m ²	Load, tension accuracy or overcooling factors
Constant Loads and Influences		
Loads from cover	according to Table 10.1	---
Weight of walls and columns	according to plan	1.1
Radial effect of stressed reinforcement	the same	1.1 (0.9)
Temporary and Long Term Loads and Influences		
Loads from cover	according to Table 10.1	---
Pressure of product	according to formula $p=Hy$	1.1
Excess pressure in the gas space	according to Table 10.1	---
Processing equipment	according to weight of equipment	1.2 (0.9)
Temperature effects	---	1.1
Ground water pressure	---	---
Short Term Loads and Influences		
Loads from cover	according to Table 10.1	---
Water pressure (in testing tanks)	according to the formula $p=Hy$	1.0
Special Loads and Influences		
Seismic effects	According to special technical specifications	

Remarks. The values of the load, tension accuracy, overheating or overcooling factors indicated in Table 10.1-10.3 are taken for those cases where reduction of the corresponding loads leads to deterioration of the operation of the structure.

2. The radial effect of prestressing ring reinforcement is determined according to the controlled stress in relation to the particular stage of operation of the element, the conditions of reinforcement stressing and losses in according with CN and R II-B.1-62

The stresses at the points where tank wall connect with bottoms and covers in statically indeterminate tank constructions are determined according to the diagrams shown in Figure 10.1.

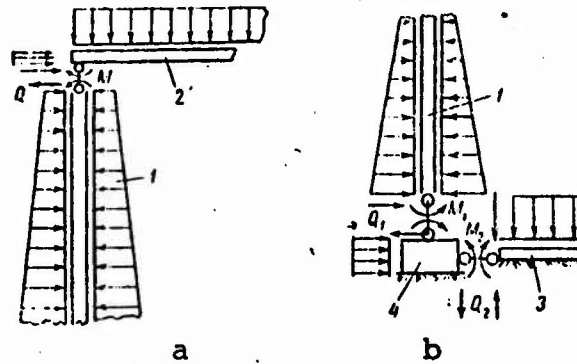

Fig. 10.1. Basic diagrams of tanks for calculating the joints between a wall and a cover (a) and a wall and a bottom (b). 1- wall; 2- cover; 3- bottom; 4- thickened part of bottom

In the walls of cylindrical tanks having radially moveable support on the bottom the annular stresses from a axisymmetrical load, distributed linearly (hydrostatic load, ground pressure), are determined according to the formula

$$T_0 = pr_m. \quad (10.2)$$

where p is the radial pressure on the wall in the level under consideration in kg-f/cm^2 ; r_m is the radius of the midplane of the wall in cm.

The bottoms and walls of reinforced concrete tanks are calculated from strength conditions and for the formation or opening of cracks. In addition in a number of cases tank covers also are calculated for deformations.

In the case of reinforcing a bottom with stressed reinforcement the bottom belongs to the first category of crack resistance and is calculated for crack formation. Calculation is performed for the following cases of loads:

a) for stresses from calculated loads without taking account of temperature effects:

b) for stresses from standard loads taking account of temperature effects; the concrete of the bottom is assumed to be prestressed to 20-25 kg/cm²

Bottoms, reinforced with unstressed reinforcement, are calculated for cracks opening from the stresses of standard loads taking account of temperature effects.

In tanks without internal lining the width of crack opening must be no more than 0.1 mm, and with internal lining - no more than 0.2 mm.

Walls are calculated as constructions of the first category of crack resistance, that is, according to the formation of cracks from stresses from calculated loads taking account of temperature effects. Opening of horizontal cracks to a width of 0.1 mm is allowed.

If the tank walls are reinforced with unstressed reinforcement, cracks in them from bending are allowed to open to a width of not more than 0.1 mm, and cross-cracks from annular stresses must not exceed 0.05 mm. Losses of prestressed ring reinforcement are determined according to table 14 in CN_{an} R II-B.1-62, losses from the settling and creak of concrete in prefabricated tanks with vibrated concrete joints being determined as for monolithic constructions, assuming the Young's modulus and cubic hardness of the concrete for the whole wall to be equal to the hardness and Young's modulus of the concrete of the joints at the moment of twisting.

Covers of tanks (cylindrical and rectangular) reinforced with prestressed reinforcement are in the second category of crack resistance and are calculated according to the formation of cracks from standard loads.

In covers, reinforced with unstressed reinforcement, opening of cracks of not more than 0.1 mm from a standard load is allowed.

§ 3. Static Calculation of Cylindrical Reinforced Concrete Tanks

The wall of a cylindrical tank is an axisymmetrical cylindrical shell, rigidly connected with the bottom of the tank. If the tank wall were able to move freely relative to the bottom and were subjected to loads (uniform, hydrostatic or from ground pressure), the shell would experience only annular stresses (stretching or compressive). In the case of the presence of a rigid connection with the bottom, the shell, at the point of its contact with it, is not deformed in the radial direction (we consider the bottom to be inelastic) and, consequently, the annular stresses of the shell at this point are equal to zero.

The elastic line (deformation) of the shell from a hydrostatic load has the form shown in Figure 10.2, that is, bending moments arise in the meridional direction of the shell.

The main task of a static calculation of the wall (shell) of a cylindrical tank is to determine the bending moment and the shearing force, arising from hydrostatic pressure, ground pressure and the load from the twisted stressed reinforcement at the point where the wall connects with the bottom.

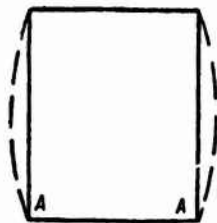

Fig. 10.2. Deformation of a tank wall in the case of its rigid connection with the bottom and cover.

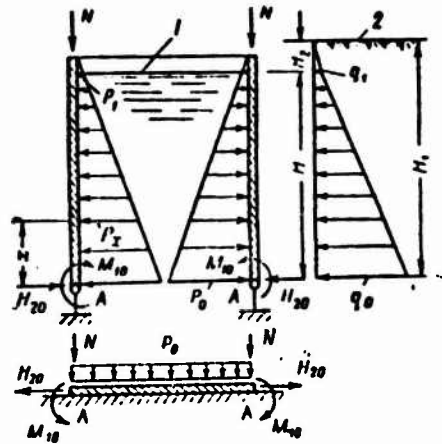

Fig. 10.3. Calculating diagram of a tank for determining M_{10} and H_{20} and the effective loads:

p_1 - hydrostatic load; q_1 - ground pressure; N - vertical load from the cover and weight of the wall;

1- product level; 2- level of tank covering.

The basic system for calculating cylindrical tanks, in which the wall is rigidly connected with the bottom and the cover or only with the bottom, assumes a cylindrical shell, in the first case cut off from the bottom and the cover, and in the second case, only from the bottom. In this case the construction of the bottom is considered to be a plate on an elastic base (ground). At the point where the structure is divided into its constituent diagrams it is necessary to apply the effective bending moments and shearing forces in these sections (Fig. 10.3); to determine these is the task of the calculation.

Figure 10.3 shows the simplest bottom construction - a flat plate which occurs only in tanks of monolithic construction. The design of the bottom is somewhat more complicated for tanks of prefabricated constructions (see Fig. 10.1).

The bending moments and shearing forces sought are determined by solving the canonical continuity equations of the deformations

of the shell, bottom and cover at the points of their division. For comparing the continuity equations of the deformations it is necessary to determine the values of the unit deformations at the points of division of the construction from the unknown lines (M and H) and the deformations from external loads for each component calculating diagram. It is necessary to note that rigid connection of a tank wall with a cover is used only in the case of a prestressed cover (for example, with a water screen arrangement) and in other cases the cover sits free on the wall. As will be shown below, the wall (shell) of a reinforced concrete cylindrical tank, thanks to the great ratio of its length to its thickness, may be considered to be a shell of infinite length, that is, to consider that deformations of one end of the shell are not reflected in deformations of the other end. This simplifies the calculation significantly.

Determination of the External Loads Acting on a Tank

The values of the external loads and load factors are taken according to the data in Section 10.1. The following basic loads (see Fig. 10.3) act on the tank wall and bottom (with the cover freely supported on the wall):

- a) superfluous unknowns - M_{10} and H_{20} ;
- b) hydrostatic load from the product (p_0) including pressure in gas space (p_1)

$$p_0 = 1.10 \gamma_{pr} H + p_1 \quad (10.3)$$

$$p_1 = 0.2 \cdot 1.20 \quad (10.4)$$

where γ_{pr} is the volume weight of the product, 1.10-1.20 are the load factors:

c) the ground pressure on the tank wall

$$q_0 = \gamma_s \bar{H}_1 \tan^2 \left(45 - \frac{\varphi}{2} \right) 1.3r; \quad (10.5)$$

$$q_1 = \gamma_s \bar{H}_2 \tan^2 \left(45 - \frac{\varphi}{2} \right) 1.30; \quad (10.6)$$

$$\bar{H}_1 = H_1 + \frac{p_{\text{temp}}}{\gamma_s}; \quad (10.7)$$

$$\bar{H}_2 = H_2 + \frac{p_{\text{temp}}}{\gamma_s}; \quad (10.8)$$

where p_{temp} is the temporary load on the territory adjacent to the tank (tractor, bulldozer, etc.);

d) the force N from the weight of the cover proper and temporary loads.

In addition to the above mentioned loads, in the calculations it is necessary to consider:

a) in the case of rigid connection between tank wall and cover - the extraneous unknowns (M and H) in the upper unit of the tank wall;

b) the load from temperature effects, vacuum, etc.

Deformation Notation and Rule of Signs

We shall use the following notation for single boundary deformations of the wall and bottom from the action $M_{10} = 1$ and $H_{20} = 1$ (absolute values), analogous to the notation in chapter 4: δ_{11} is the angle of rotation from the action $M_{10} = 1$, increased by E times; δ_{12} is the same from the action $H_{20} = 1$; δ_{22} - is the displacement at the point of application H_{20} from the action $H_{20} = 1$, increased by E times; δ_{21} is the same from the action $M_{10} = 1$; Δ_{1p} is the angle of rotation at the point of application of M_{10} from the action of the external load p, increased by E times; Δ_{2p} is the displacement at the point of application of H_{20} from the action of the external load p, increased by E times; Δ_{1N} and Δ_{2N} are the corresponding deformations from the force N.

The general expression of deformation δ_{mn} symbolizes the deformation in the direction of the extraneous unknown m' from the action of the force (load) n'.

Im comparing the canonical deformation continuity equations the angles of rotation and displacement are assumed to be positive when the directions coincide with the directions of the extraneous unknowns (M and H). Hence it follows that the signs of the principle deformations δ_{11} and δ_{22} always are positive.

The signs of the deformations from an external load are considered when comparing the canonical deformation continuity equations according to the same rule.

We note that the equality $\delta_{mn} = \delta_{nm}$ always occurs.

Determining the Deformations (Angles of Rotation and Displacement) of the Wall (Shell) of a Cylindrical Tank

We are interested in the deformations at the point of application of M_{10} and H_{20} , that is, the points A. Bearing in mind

the identity of a cutout strip of the shell (wall) with a beam, lying on an elastic base, for determining the deformations of interest to us we shall make use of formulas (4.37) - (4.41), having replaced Q by H and q_0 and q_1 by p_0 and p_1 , in them. As a result we shall have the following values of single deformations from the extraneous unknowns and deformations from external loads, increased by E times:

a) the angle of rotation of the point A under the action $M_{10} = 1$

$$\delta_{11}^w = \frac{E}{\beta D};$$

b) the displacement of the point A under the action M_{10} or the angle of rotation of the point A under the action $H_{20} = 1$

$$\epsilon_{11}^w = \delta_{12}^w = \frac{E}{2\beta^2 D};$$

c) the displacement of the point A under the action $H_{20} = 1$

$$\delta_{22}^w = \frac{E}{2\beta^3 D};$$

d) the movement of the point A from an external load is taken according to formulas (4.41):

in the absence of pressure in the gas space of the tank

$$\Delta_{1p_0}^w = \frac{\gamma}{h_w} E;$$

$$\Delta_{2p_0}^w = \frac{\gamma}{h_w} EH.$$

where $k^w = E\delta/r^2$; $\gamma = p_0/H$;

in the presence of pressure in the gas space of the tank

$$\Delta_{1p}^w = \frac{\gamma_1}{k_w} E; \quad (10.9)$$

$$\Delta_{2p}^w = \frac{\gamma_1}{k_w} EH. \quad (10.10)$$

where $\gamma_1 = p_0 - p_1/H$.

According to the rule of signs accepted and the calculating scheme presented in fig. 10.3, the values of Δ_{1p}^w will enter into the canonical deformation continuity equations with the sign "+" and the values of Δ_{2p}^w - with the sign "-";

e) in determining deformations of the shell from ground pressure it is possible to use the same formulas as for hydrostatic pressure, having substituted $p_0 = -q_0$ and $p_1 = -q_1$; the values of q_0 and q_1 are taken according to formulas (10.5) and (10.6).

Determining Single Deformations from Extraneous Unknowns (Angles of Rotation and Displacement) and Deformations from External Loads in Tank Bottoms

The values of the deformations of a cylindrical tank bottom significantly influence its construction, which determines its rigidity, and by the characteristics of the base (ground), reflected in the formulas by the bed coefficient k .

Existing designs for bottoms and their connection with tank walls may be classified into the following four types:

1) an unstressed bottom in the form of a flat plate, rigidly connected with a tank wall of monolithic reinforced concrete;

2) an unstressed bottom, allowing radial movement and rotation of the tank wall at the point of their junction;

3) an unstressed bottom rigidly connected with a wall of prefabricated panels;

4) a stressed bottom rigidly connected with a wall of prefabricated panels.

We shall examine each type of bottom.

An unstressed bottom in the form of a flat plate is its most simple construction. The bottom is calculated as a strip of a plate 1 m wide, lying on an elastic base. A structural model is shown in fig. 10.3. In this case formulas (4.37) and (4.38) may be applied completely to the bottom plate, and the deformations at point A, increased by E times, will be expressed by the following formulas:

a) from the action of the moment $M_{10} = 1$

(10.11)

$$\delta_{11}^{\text{bot}} = \frac{4E\beta^3}{k};$$
$$\delta_{12}^{\text{bot}} = \delta_{21}^{\text{bot}} = 0;$$

b) from the action $H_{20} = 1$

$$\delta_{22}^{\text{bot}} = 0;$$

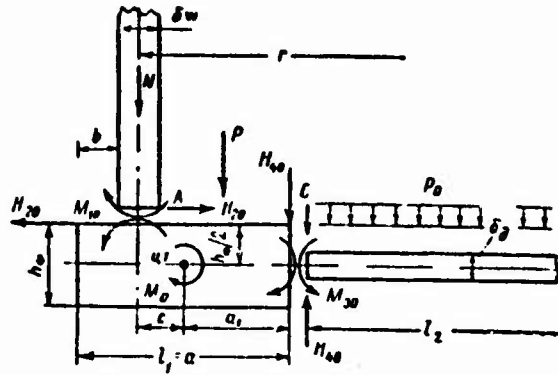

Fig. 10.4. Structural model of support unit (section A) in the case of a bottom of the third type.

c) from the action of the force N

$$\delta_{1N}^{bot} = \frac{N}{2\beta^2 J_{bot}}; \quad \Delta_{2N}^{bot} = 0. \quad (10.12)$$

Deformations do not arise in the plate from the pressure of the product. With a construction of the junction of the bottom with the wall, allowing radial movement of the wall and rotation relative to the bottom plate (the second type) deformations arise in the plate only from the force N (formula (10.12)).

The third type of bottom, connected with the wall in a groove, is used in tanks with a prefabricated wall and when it is not possible to prestress the tank bottom. As is seen in fig. 9.9, at the junction of the wall and bottom there is a significant thickening of the bottom, which influences the amount of deformations. A structural model of a bottom for the given case is taken conditionally according to fig. 10.4.

For determining M_{10} and H_{20} it is necessary to determine M_{30} and H_{40} (the bending moment and shearing force at point C), where the bottom plate changes its thickness abruptly. Making a cut at the point C and applying the stresses M_{30} and H_{40} to the point of the cut, we are able to put together the

canonical continuity equations of the deformations of the bottom sections l_1 and l_2 . The short bottom section l_1 is of significant thickness, which is taken as the average of the bottom thicknesses at points A and C. The ratio of the length of section l_1 to the thickness h_{av} usually is assumed to be 3-4, which makes it possible to consider this section to be absolutely rigid (a stamp). The bottom plate section l_2 is a plate of infinite length, lying on an elastic base. From these conditions we determine the deformation equations for plate sections l_1 at points A and C and for plate section l_2 at point C.

1. Angle of Rotation of Plate Section l_1

We shall designate with the index "F" all deformations concerning section l_1 . Since section l_1 is infinitely rigid, its angle of rotation (increased by E times), as that of a ring with radius r, lying on an elastic base with the bed coefficient k, from the action of the moment $M_0 = 1$ will be

$$\delta_{00}^F = \frac{12Er^2}{r^2 b_0^3 k + E l_1 h_F^3} \quad (10.13)$$

where b_0 is the plate width, equal to 1.

M_0 is the moment of all forces relative to the center of gravity of plate section l_1 (see fig. 10.4). Where $h_{av} \leq 0.5$ m it is possible to use formula (10.14)

$$\delta_{00}^F = \frac{12EM_0}{b_0^3 k} \quad (10.14)$$

$$M_0 = M_{30} + H_{40} a_1 - M_{10} - H_{20} \frac{h_F}{2} + \sum M_p \quad (10.15)$$

where $\sum M_p$ is the moment of all external forces relative to the center of gravity.

In fig. 10.14 the external load consists of the forces N and P. N is the normal force of a wall panel from the weight of the wall and the load of the cover; P is the pressure of the product on the section $(l_1 - b - h_w)$

$$P = p_0(l_1 - b - \delta_w).$$

2. Displacement of Plate Section l_1

Since section l_1 is absolutely rigid, then its displacements will consist of:

along the horizontal (in the direction of the force H_{20} from $M_0 = 1$)

$$\delta_{20}^F = \delta_{00}^F \frac{h_F}{2}; \quad (10.16)$$

along the vertical (in the direction of the force H_{40})

$$\delta_{40}^F = \delta_{00}^F a_1.$$

The settling of plate section l_1 from the action of all vertical forces (increased by E times) is

$$\Delta_{42p}^F = \frac{E \sum P}{kl_1}, \quad (10.17)$$

where

$$\sum P = N + P + H_{10} + P_F.$$

E is the modulus of elasticity of the concrete; P_F is the weight of plate l_1 .

3. Deformations of Bottom Plate Section l_2 .

We shall designate with the index "b" all deformations concerning plate l_2 . Since plate l_2 is semi-infinite for determining

the deformations we shall make use of formulas (4.37) and (4.38) (having increased their values by E times), assuming $x=0$.

The angle of rotation of the point C from the action $M_{30} = 1$ is

$$\delta_{33}^{\text{bot}} = \frac{4E\beta^3}{k}. \quad (10.18)$$

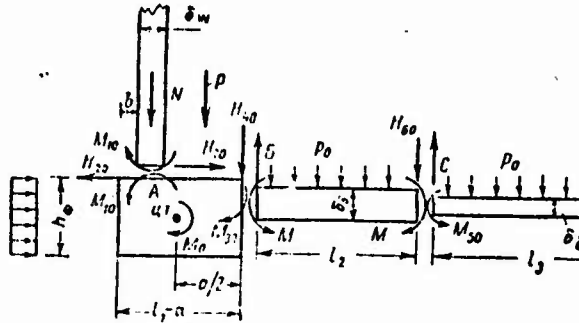

Fig. 10.5. Structural model of support unit with a bottom of the fourth type.

The same from the action $H_{40} = 1$

$$\delta_{33}^{\text{bot}} = \frac{2E\beta^2}{k}. \quad (10.19)$$

The displacement of point C from the action $H_{40} = 1$

$$\delta_{44}^{\text{bot}} = \frac{1}{2\beta^3 l_{\text{bot}}}; \quad \epsilon_{33}^{\text{bot}} = \delta_{33}^{\text{bot}}. \quad (10.20)$$

The settling of the plate from the action of the weight of the product (p_0)

$$\Delta_{4p_0}^{\text{bot}} = \frac{p_0 l^2}{k}, \quad (10.21)$$

where β is the coefficient of deformation; I_b is the moment of inertia of a plate 1m wide.

With the action only of the ground pressure on the tank wall $\delta_{33}^{\text{bot}} = 0$.

The fourth type of bottom construction is used when the bottom is prestressed. Fig. 9.7 shown the construction of the junction between bottom and wall, and fig. 10.5 - a structural model of this unit.

In a static calculation, in addition to the extraneous unknowns in the support unit (M_{10} and H_{20}), it is necessary to determine the extraneous unknowns in the top unit of the tank.

From the theory of cylindrical shells it is known that if the height of a shell (H) is greater than $2.5(r\delta)^{\frac{1}{2}}$, then the shell may be considered to be long and deformations of one end of it do not influence deformations of the other. This makes it possible to perform static calculations of the support (lower) and upper units independently. Tanks of large capacity have the following dimensions: $H = 9\text{m}$, $\delta = 0.25\text{m}$ (mean value) and $r=30-35\text{m}$. Consequently, $2.5 (r\delta)^{\frac{1}{2}} = 2.5 (35 \cdot 0.25)^{\frac{1}{2}} = 8.4 < 9.0$. Therefore, the shell is long.

If the thickness of the tank wall is constant with height (or changes insignificantly), the deformations of the wall in the support section may be determined according to formulas (4.37) - (4.41), taking the bottom thickness of the wall in them, in addition to the deformations from external loads in the upper unit. With the action of hydrostatic pressure and pressure in the gas space (p_1), the deformations in the upper point will be $\Delta_{1p}^u = (\gamma_1/k^w)E$, and Δ_{2p}^u where $x = H$ will be

$$\Delta_{2p}^u = \frac{p_1 r^3}{\delta w} EH. \quad (10.22)$$

Since the cover and bottom in tanks of this construction are subjected to prestressing, free terms, characterizing the deformation of the bottom and the cover from compression, (δ_{2H}^b and δ_{2H}^c), additional appear in the canonical equations for the top and bottom units.

For determining unit deformations we divide the support part of the bottom into three sections: l_1 , l_2 and l_3 . Section l_1 represents an absolutely rigid element of height h_F (usually equal to 150 cm) and length 150 cm; for determining its unit deformations it is necessary to use formulas (10.13) - (10.17). Section l_2 has the average height 30-35 cm and the length 2-2.5 m. The moment of inertia of this section $I = 1.035^3/12 = 0.0036 \text{ m}^4$ where $k = 5 \cdot 10^3 \text{ T/m}^3$ and $E = 2 \cdot 10^6 \text{ T/m}^2$. The rigidity characteristic of section l_2 will be

$$\beta = \sqrt[4]{\frac{k}{4EI}} = \sqrt[4]{\frac{5 \cdot 10^3}{4 \cdot 2 \cdot 10^6 \cdot 0.0036}} = 0.65.$$

A beam (or plate), lying on an elastic base is considered to be short if its reduced half length $L = \beta \frac{1}{2} l$ is greater than 0.6 and less than 2. In our case $L = 0.65(2.5/2) = 0.81 > 0.6$, bottom section l_2 is a short plate, lying on an elastic base.

In a short plate, as opposed to a plate of infinite length (long plate), deformations of one end of the beam influence deformations of the other end, which must be considered in calculation.

Table 10.4 gives the unit deformations of the end sections of a short beam with different L , δ_{33}^b , $\delta_{43}^b = \delta_{34}^b$, δ_{55}^b , $\delta_{53}^b = \delta_{65}^b$, which may be used in comparing the canonical continuity equations of deformations at points B and C (see fig. 10.5), having increased them by E times.

We shall designate with the index "b" deformations of sections l_2 .

As far as bottom section l_3 is concerned, the formulas presented above are extended to it for determining unit deformations, that is,

$$\xi_{33}^{bot} = \frac{4\beta^3 E}{k}; \quad \xi_{43}^{bot} = \delta_{33}^{bot} = \frac{2\beta^2 E}{k}; \quad \delta_{33}^{bot} = \frac{1}{2\beta^3 J_{bot}}; \quad \Delta_{33}^{bot} = \frac{P_0 E}{k}. \quad (10.23)$$

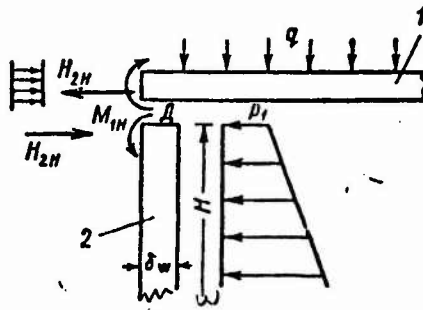

Fig. 10.6. Structural model of the upper unit (D) in case of rigid connection between wall and cover.

1- cover; 2- wall

As was indicated above, if the bottom and cover of a tank are subjected to prestressing, it is necessary to consider the deformations of the cover and bottom from compression when comparing the canonical continuity equations of deformations in the top (point D) and bottom (point A) units. We shall symbolize the deformations of the bottom as δ_{2H}^{bot} and δ_{2H}^c . If as a result of prestressing the stresses σ_H^{bot} and σ_H^c arise in the bottom and cover respectively, then the reduction in the diameter of the bottom and cover will be

$$\Delta D^{bot} = \frac{\sigma_H^{bot}}{E} \left(1 - \frac{1}{m}\right) D \text{ and } \Delta D^c = \frac{\sigma_H^c}{E} \left(1 - \frac{1}{m}\right) D \quad (10.24)$$

and the displacement of the support and upper units of the tank wall, increased by E times, will be

$$\delta_{2H}^{bot} = \sigma_H^{bot} \left(1 - \frac{1}{m}\right) r; \quad \delta_{2H}^c = \sigma_H^c \left(1 - \frac{1}{m}\right) r, \quad (10.25)$$

where r is the tank radius; 1/m is Poisson's ratio, for concrete it is possible to assume 1/m = 0.167.

In a calculation of the upper unit the absolute values of single deformations will be equal to (fig. 10.6):

$$\delta_{11}^u = \frac{E}{\beta D}; \quad \delta_{22}^u = \frac{E}{2\beta^2 D}; \quad \delta_{12}^u = \delta_{21}^u = \frac{E}{2\beta^2 D}. \quad (10.26)$$

From the hydrostatic load and pressure in the gas space (p_0) the unit deformations will be, according to formulas (10.9) and (10.22),

$$\Delta_{1p} = \frac{\gamma_1}{k} E; \quad \Delta_{2p} = \frac{p_1 r^2}{\delta w}. \quad (10.27)$$

Table 10.4

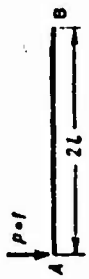
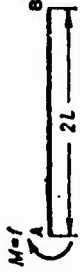
Diagram of beam	Deflection	Angle of Rotation
	$y_p = -\omega_p^2 \frac{\beta^3}{kb}$	$\varphi_p = -\varphi_p^2 \frac{\beta^2}{kb}$
	$y_M = \omega_M^2 \frac{\beta^3}{kb}$	$\varphi_M = \varphi_M^2 \frac{\beta^2}{kb}$
Deformation signs	Deflection positive if directed upwards	Angle of rotation positive if clockwise

Unit Motions	Reduced half length of beam											
	0,7		0,8		0,9		1,2		1,4		1,5	
	Point A	Point B	Point A	Point B	Point A	Point B	Point A	Point B	Point A	Point B	Point A	Point B
φ_p^2	3.463	+2.827	2.86	+2.045	2.492	+1.487	2.062	+0.502	2.007	+0.164	2.001	+0.056
φ_M^2	6.422	+3.681	5.219	+2.159	4.63	+1.224	4.062	-0.038	4.018	-0.297	4.015	-0.340
ω_p^2	2.959	-1.353	2.619	-1.139	2.43	-0.959	2.099	-0.529	2.028	-0.313	2.013	-0.226
ω_M^2	3.463	-2.827	2.860	-2.045	2.492	-1.487	2.062	-0.502	2.007	-0.164	2.001	-0.056

Note: Table 10.4 is borrowed from the book by B. G. Kovenev and E. I. Chernigovskiya "Calculation of Plates on an Elastic Base". Moscow, Gosstrojizdat, 1962.

In tanks with a prestressed cover the construction of the latter usually consist of flat plates, laid along wide (90 cm) beams. Therefore, with sufficient accuracy the cover may be considered to be a plate (of unit width) completely fastened at the point where it rests on the beam. Then the unit motions of the cover at the point of connection with the tank wall point D will be (increased by E times)

$$\delta_{11}^c = \frac{1l}{4I_c}; \Delta_{1q}^c = \frac{ql^3}{48I_c}, \quad (10.28)$$

where l is the plate span; I_c is the moment inertia of the cover plate; q is the external load on the cover, including its own weight.

Formulation of Canonical Continuity Equations of Deformations

We shall use the structural model shown in fig. 10.3, i.e., where the wall is rigidly connected only with the bottom which represents a flat plate lying on an elastic base (first type). The external loads are the hydrostatic pressure of the product (p_0) and the force N . We shall designate with the index "w" the deformations of the tank wall, and with the index "bot" the deformations of the bottom.

The angle of rotation of the wall and bottom with respect to one another at the point A is equal to zero.

$$[\delta_{11}^w + \delta_{11}^{bot}] M_{10} - \delta_{12}^w H_{20} + \Delta_{1p}^w + \Delta_{1N}^{bot} = 0. \quad (10.29)$$

The displacement of the wall and the bottom with respect to one another at the point A is equal to zero.

$$[\delta_{22}^w + \delta_{22}^{bot}] H_{20} - \delta_{21}^w M_{10} - \Delta_{2p}^w = 0. \quad (10.30)$$

The extraneous unknowns in these equations are M_{10} and H_{20} .

The force N - the weight of the wall itself and the load on the cover, transmitted to the tank wall does not communicate any deformations ($\delta_{1N}^W = \delta_{2N}^W = 0$) to the sectional structural model of a cylindrical shell. As far as the bottom plate, lying on an elastic base, is concerned, the force N causes an angle of rotation at the point A (Δ_{1N}^{bot}) in it. Angles of rotation (δ_{1p}^W) and displacement (Δ_{2p}^W) arise from the action of hydrostatic pressure in the shell (point A).

The value of the unit deformations for a bottom of the given type are taken according to formulas (10.11) - (10.13). Having solved equations (10.29) and (10.30) for each type of load - hydrostatic, ground pressure (q) and force N , we determine the extraneous unknowns M_{10} and H_{20} .

In the case of a bottom construction allowing radial movement and rotation of the tank wall in the support unit (second type), canonical continuity equations of deformations need not be put together, since the tank wall and bottom are capable of being deformed independently. The annular stresses T are determined as for a momentless shell

$$T = \gamma(H - z)r, \quad (10.31)$$

where x is reckoned from the support unit.

Meridional moments in the shell do not arise. The bottom plate is calculated from the effect of the force N according to the usual formulas for beams lying on an elastic base.

In the case of a bottom construction of the third type in accordance with the structural model shown in fig. 10.4 we formulate

the continuity equations of the deformations in sections A and C in the case of the action of hydrostatic pressure (p_0) and vertical force N.

The Section at Point C

The equation of the angles of rotation is

$$\delta_{00}^F M_0 + \delta_{30}^{bot} M_{30} - \delta_{40}^{bot} H_{40} = 0. \quad (10.32)$$

The equation of the displacements is

$$\delta_{00}^F M_0 + \Delta_{40}^F \Sigma p - \delta_{30}^{bot} M_{30} - \delta_{40}^{bot} H_{40} - \Delta_{40}^{bot} = 0. \quad (10.33)$$

Having substituted into equations (10.32) and (10.33) the values of the deformations according to formulas (10.13) - (10.17) and having solved them, we determine M_{30} and H_{40} as functions of M_0 . Having substituted the values obtained for M_{30} and H_{40} into formula (10.15), we determine M_0 as a function of M_{10} and H_{20} .

The Section at Point A

The equation of the angles of rotation is

$$\delta_{11}^W M_{10} - \delta_{00}^F M_0 - \delta_{20}^W H_{20} + \Delta_{10}^W = 0. \quad (10.34)$$

The equation of the displacements (in the direction H_{20}) is

$$\delta_{22}^W H_{20} - \delta_{21}^W M_{10} - \Delta_{20}^W - \delta_{20}^F M_0 = 0. \quad (10.35)$$

Having substituted into equations (10.34) and (10.35) values of M_0 , expressed by M_{10} and H_{20} , and having solved them, we determine the desired M_{10} and H_{20} . In equations (10.32), (10.33),

(10.34) and (10.35) the signs of the unit deformations are taken according to the rule discussed above and as applied to the structural model (fig. 10.6).

For convenience in using equations (10.34) and (10.35) we introduce the following symbols:

$$n = \frac{r}{\delta w}; \quad (10.36)$$

$$c = \frac{r}{Hw}; \quad (10.37)$$

$$\bar{p} = p_0 - p_1 \quad (10.38)$$

Having substituted these symbols into the values of the unit deformations, we obtain

$$\beta = \frac{1.31}{\delta w \sqrt{n}}, \quad \delta_{11}^w = \frac{9n^2 \sqrt{n}}{r^2}; \quad \delta_{12}^w = \delta_{21}^w = \frac{3.4n^2}{r}; \quad \delta_{22}^w = 2.62n \sqrt{n}; \quad \Delta_{1p}^w = nc\bar{p}; \quad \Delta_{2p}^w = nrp_0; \quad (10.39)$$

and equations (10.34) and (10.35) will acquire the form

$$\frac{9n^2 \sqrt{n}}{r^2} M_{10} - \frac{3.4n^2}{r} H_{20} - \delta_{00}^F M_0 + nc\bar{p} = 0; \quad (10.40)$$

$$2.62n \sqrt{n} H_{20} - \frac{3.4n^2}{r} M_{10} - \delta_{00}^F M_0 - nrp_0 = 0. \quad (10.41)$$

Equations (10.40) and (10.41) are formulated for the action of the load of the product (p_0) on the tank. For the load from ground pressure on the tank it is possible to use the same equations, performing the following substitutions:

$$\bar{p} = -q \text{ and } p_0 = q_0. \quad (10.42)$$

where $\bar{q} = q_0 - q_1$ (see fig 10.6). In addition the force P and Δ_{4p}^{bot} must be considered to be equal to zero.

Having solved equations (10.40) and (10.41) where the values of M_0 are expressed by M_{10} and H_{20} , we determine the extraneous unknowns M_{10} and H_{20} .

If the bottom and cover of the tank are subjected to prestressing (fourth type), then according to the structural models shown in figs. 10.5 and 10.6, in order to determine the extraneous unknowns it is necessary to formulate canonical continuity equations of the deformations in sections A, B, and C for the bottom support of the unit of the wall and for the section D of the top unit where the tank wall joins with the cover.

In view of the fact that we have a long shell, the solution of these equations may be derived independently of one another. In the case of prestressing of tank bottoms and covers, deformations, which must be considered in calculation, arise in the latter, but for simplicity of presentation first we shall examine the order formulation of the continuity equations of deformations without taking account of deformations) from prestressing, and then the stressed state of the construction from prestressing.

Let us consider the bottom unit of the connection between the tank wall and the bottom (fig. 10.5).

Section C

$$\delta_{22}^b M_{50} + \delta_{26}^b H_{60} + \delta_{23}^b M_{30} + \delta_{24}^b H_{40} + \delta_{25}^{bot} M_{50} - \delta_{25}^{bot} H_{60} = 0; \quad (10.43)$$

$$\delta_{33}^b H_{60} + \delta_{35}^b M_{50} + \delta_{34}^b H_{40} + \delta_{32}^b M_{30} + \delta_{36}^{bot} H_{60} - \delta_{36}^{bot} M_{50} + \Delta_{3p}^b - \Delta_{3p}^{bot} = 0. \quad (10.44)$$

For determining the signs of δ_{53}^b , δ_{64}^b and δ_{63}^b it is necessary to consider the directions of the unit deformations according to the data in table 10.4.

Section B

$$\delta_{60}^F M_0 + \delta_{20}^b M_{30} + \delta_{30}^b M_{50} - \delta_{24}^b H_{40} + \delta_{34}^b H_{60} = 0; \quad (10.45)$$

$$\delta_{60}^F M_0 + \delta_{44}^b H_{40} - \delta_{42}^b M_{30} + \delta_{46}^b M_{50} + \delta_{48}^b H_{60} + \Delta_{4\Sigma p}^F - \Delta_{4p}^b = 0. \quad (10.46)$$

Section A

$$\delta_{11}^W M_{10} - \delta_{12}^W H_{20} - \delta_{60}^F M_0 + \Delta_{1p}^W = 0; \quad (10.47)$$

$$\delta_{22}^W H_{20} - \delta_{21}^W M_{10} - \Delta_{20}^F - \Delta_{2p}^W = 0. \quad (10.48)$$

Having substituted into the given equations the values of the unit motions from formulas (10.13) - (10.17) and (10.23) and also from table 10.4 and having solved them together, we determine the extraneous unknowns M_{10} , M_{30} , H_{50} , H_{20} , H_{40} and M_{50} . For determining the extraneous unknowns from ground pressure on the tank wall in these equations it is necessary to perform substitution according to formula (10.24) and to consider $\delta_{6p}^b = \delta_{6p}^{bot} = \delta_{4p}^b = 0$ and the force $P = 0$.

We shall now examine the formulation of the equations for determining the extraneous unknowns (M_{1H} and H_{2H}) in the upper unit (fig. 10.6).

$$\delta_{11}^u M_{1H} - \delta_{12}^u H_{2H} - \Delta_{1p}^u + \xi_{11}^c M_{1H} + \Lambda_{1H}^c = 0; \quad (10.49)$$

$$\delta_{22}^u H_{2H} - \delta_{21}^u M_{1H} - \Lambda_{2p}^u = 0. \quad (10.50)$$

The values of the unit deformations in unit equations (10.49) and (10.50) are taken according to formula (10.26). Having solved the given equations we determine the M_{1H} and M_{2H} sought.

Determining The Meridional Moments and Annular Stresses in a Cylindrical Tank Wall

If the boundary conditions of the shell are known, i.e., the values of M_{10} , H_{20} , M_{1H} and M_{2H} , then the meridional moment and annular conditions T may be determined according to the following formulas (for hydrostatic pressure):

bottom part of wall

$$M_{1x} = M_{10} \varphi_{\beta x} - \frac{H_{20}}{\beta} \zeta_{\beta x}; \quad (10.51)$$

$$T_{2x} = -2r\beta (H_{20} \theta_{\beta x} - M_{10} \psi_{\beta x}); \quad (10.52)$$

top part of wall

$$M_{1x}^u = M_{1H} \varphi_{\beta x} - \frac{H_{2H}}{\beta} \zeta_{\beta x}; \quad (10.53)$$

$$T_{2x}^u = -2r\beta (H_{2H} \theta_{\beta x} - M_{1H} \psi_{\beta x}). \quad (10.54)$$

The coefficients $\phi_{\beta x}$, $\psi_{\beta x}$ and $\zeta_{\beta x}$ are tabulated (see Ch. 4), x being reckoned from the support section (point A) for the bottom part of the wall, and from the top of the wall (point D) for the top part of the wall.

The calculated T_{2x} are summed with T_{20} according to formula (10.81).

Determining the Stresses in a Cylindrical Tank Wall from Winding Stressed Ring Reinforcement Onto It.

Stressed ring reinforcement is wound onto a cylindrical tank wall in order to compensate for the stretching stresses which arise

in the wall from the action of the hydrostatic pressure of the stored product.

In the case of an unstressed bottom (third type) and the wall fitted into a groove the wall can rotate freely in the groove, since winding is performed before cementing the groove, but its radial displacement is restrained by the frictional force developing between the end of wall and the bottom of the groove. In calculating the resultant annular stresses and moments in this case it is necessary to take account of the influence of this frictional force. Considering that $M_{10} = 0$ the frictional force will be equal to

$$H_{20} = -N\phi,$$

where N is the vertical pressure transmitted through the wall during winding (before cementing unit A); ϕ is the coefficient of friction

$$M_{1x}^H = \frac{H_{20}}{\beta} \zeta_{2x} = \frac{N\phi}{\beta} \zeta_{2x}; \quad (10.55)$$

$$C_{1x}^H = N\phi \zeta_{1x}; \quad (10.56)$$

$$T_{2x}^H = T_{20}^H - C_1 \zeta_{2x}, \quad (10.57)$$

where $C_1 = 2r\beta N\phi$.

The curve of the annular stresses T_{20}^H (for a momentless shell) from winding is step-shaped, the bottom zone of winding (first belt) is equal to almost half the height of the wall and the upper winding belts are weaker T_{20}^H - the annular stresses in a momentless shell (wall) - are chosen so that the resultant annular stresses T_{2x}^H (formula (10.57) everywhere overlap the curve of the stretching annular stresses from hydrostatic pressure (t_{2x}^H). The required amount of wound reinforcement is determined by T_{20}^H . In fact, meridional moments arise in the shell during the process of winding and at points of a sharp change in annular

stresses (T_{20}^H), but, as investigations have shown, their values are small in comparison with the theoretical support moment M_{10} , and therefore they are not considered in construction.

It is convenient to perform the calculation of M_{1x}^H and T_{2x}^H in tabular form.

In constructing a tank with a prestressed bottom and top (fourth type) a static calculation depends on the order of performing the operations of stressing the wall, bottom, and cover. If winding on the wall is performed before the support unit (point A) and top unit of the wall (point B) are made monolithic, then the wall freely rests on the support plate during winding and is capable of rotating freely, and its radial displacement is hindered only by the frictional force (of the wall against the support plate). In this case in the upper unit the wall can move practically freely in the radial direction. Obviously, with such an order of performing operations the stressed state of the wall will not differ from the case with the bottom of the third type discussed above. However, in addition it is necessary to determine the influence on the stressed state of the wall of deformation of the top and cover in the case of their being stressed after the top and bottom units of the wall are made monolithic (see formula (10.25)).

For determining M_{10} and H_{20} in section A (see fig. 10.5) from the deformation of the bottom it is possible to formulate the following equations of equality of wall and bottom deformations:

$$\delta_{11}^w M_{10} - \delta_{12}^w H_{20} - \delta_{00}^t M_0 = 0; \quad (10.58)$$

$$\delta_{22}^w H_{20} - \delta_{21}^w M_{10} - \delta_{20}^t M_0 - \Delta_{211}^{bot} = 0. \quad (10.59)$$

The values of the unit deformations were presented above.

The equations for section C are analogous to equations (10.43) and (10.44), but here Δ_{6p}^b and Δ_{6p}^{bot} are equal to zero.

The equations for section B are taken according to formulas (10.45) and (10.46), assuming in them $\Delta_{4\Sigma p}^F = \Delta_{4p}^b = 0$. The moment is

$$M_0 = H_{40} \frac{l_1}{2} + M_{30} - H_{20} \frac{h_F}{2}. \quad (10.60)$$

Having solved these equations we determine the extraneous unknowns sought.

For determining M_{1H} and M_{2H} in the top section of the wall (see fig. 10.6) from the deformation of the cover we formulate an equation of equality of deformations in the unit D

$$\delta_{11}^u M_{1H} - \delta_{12}^u H_{2H} + \delta_{11}^c M_{1H} = 0; \quad (10.61)$$

$$\delta_{22}^u H_{2H} - \delta_{21}^u M_{1H} - \Lambda_{2H}^c = 0. \quad (10.62)$$

Having substituted into these equations the values of the unit deformations, cited above, and having solved them, we determine the extraneous unknowns M_{1H} and H_{2H} sought.

As a result of the solutions given above we obtain the values of M_{10} , H_{20} , M_{1H} and H_{2H} for the following loads:

- a) from hydrostatic pressure (or ground pressure);
- b) from winding stressed reinforcement onto the tank wall;
- c) from prestressing the bottom;
- d) from prestressing the cover.

Further using formulas (10.51) and (10.53), we determine for case "a" the values of M_{1x} and T_{2x} both for the upper and

lower sections of the wall. For case "b" we determine the values of M_{1x}^H and T_{2x}^H according to formulas (10.55) and (10.57). For cases "c" and "d" we find M_{1x} and T_{2x} according to the same formulas as for case "a", having assumed $T_{20} = 0$.

Summing the correspondingly obtained values, we obtain the stressed state of a tank structure for the following cases of loads:

- a) the tank is filled with product but not covered with dirt,
- b) the tank is not filled with product and covered with dirt,
- c) the tank is filled with product and covered with dirt.

With a different order of performing operations, when the stressed reinforcement is wound onto the tank wall after the top and bottom or only the bottom units of the tank wall are made monolithic, the nodal moments, shearing forces, and annular stresses from the hydrostatic (or ground pressure) load and deformations of the bottom and top are determined as discussed above, i.e., when winding onto the wall is performed before the units are made monolithic. For this case determining the stressed state of the tank wall from winding reinforcement onto it substantially differs from that discussed above.

The nature of the curves of the annular stresses T_{20}^H (and, consequently, the loads from on the wall) in a momentless shell from winding stressed reinforcement onto the tank wall is of the nature indicated in fig. 10.7a. In practice the tapered top part of the curve is accomplished in a number of steps (indicated with the dotted line). In order to determine the deformations

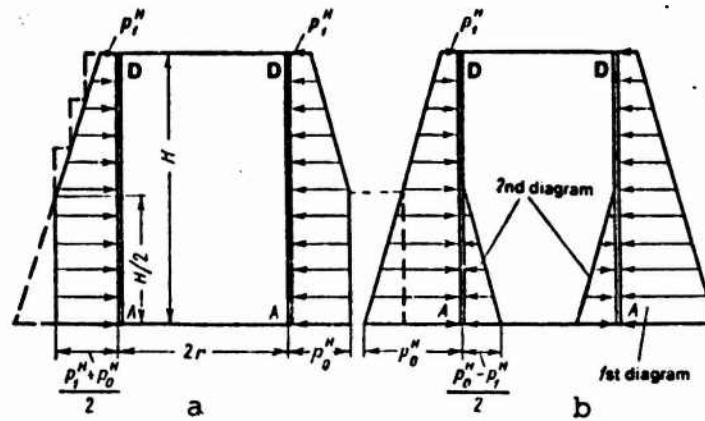

Fig. 10.7. Nature of the curve of T_{20}^H from $(p_0^H - p_1^H)$ (a) and separation into two component curves (b) for calculating unit A.

of the bottom unit from this load we divide the curve of T_{20}^H into two curves (fig. 10.7b), and replace the annular stresses by the loads on the tank wall corresponding to them. The sum of the deformations from these loads gives the deformations sought (fig. 10.8). According to the first load model (fig. 10.8a) the shell is long and the deformations of the top unit are determined by the formulas given previously

$$\Delta_{1p}^W = -\frac{rn}{H} \cdot (p_0^H - p_1^H); \quad \Delta_{2p}^W = p_0^H nr, \quad (10.63)$$

where Δ_{1p}^W is the rotation of unit A; Δ_{2p}^W is the displacement of unit A.

In order to determine the deformations of unit A from the second load model (fig. 10.8 b), which is analogous to partial filling of the tank, we cut the shell along EE; it is necessary that the as yet unknown moments M_3 be applied to the point of the cut. The lower shell in the plane EE does not have radial displacement and, consequently, in this section there will be no mutual (between shells) radial reaction. The condition of deformation continuity along the line of the imaginary cut will be expressed only by the angle of rotation of the shells formed

and the corresponding moments M_3 . The lengths of each shell (0.5H) are less than the value $2.5 (r\delta w)^{1/2}$, consequently, the shells are short. It is possible to make use of the method of correcting coefficients (c_1, c_2, \dots) presented in the book by V. I. Nikireyev and V. Ya. Shadurskiy "Practical Methods of Calculating Shells," (Moscow, Stroyizdat, 1966), for determining the ultimate deformations of these shells. The angle of rotation in the first and second shells in the section EE will be increased by E_b times from the load

$$\delta_{33} = 4\beta^3 nr C_3^{(2)}; \quad (10.64)$$

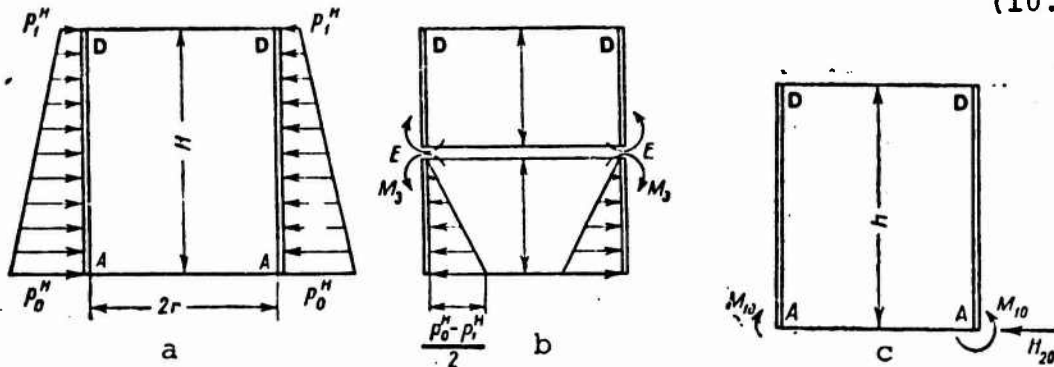

Fig. 10.8. Structural loading models for unit A.
a- first; b- second; c- model of extraneous unknowns.

$$p_0^H - p_1^H/2;$$

$$\Delta_{3p} = -\gamma_1 rn; \quad (10.65)$$

where $\gamma_1 = p_2^H - p_1^H/H$.

and M_3 is determined from the equation

$$M_3 (\delta_{33}^u + \delta_{33}^n) + \Delta_{3p} = 0, \quad (10.66)$$

hence

$$M_3 = \frac{\gamma_1}{8\beta^3 C_3^{(2)}}.$$

The deformations of unit A of the lower shell from external forces (M_3 and p) will be

$$\delta_{13} = 4\beta^3 nr \vec{C}_3; \quad \Delta_{1p} = \gamma_1 rn; \quad (10.67)$$

$$\delta_{22} = 2\beta^2 nr \vec{C}_2; \quad \Delta_{2p} = \gamma_1 H nr. \quad (10.68)$$

The deformations of unit A from the extraneous unknowns M_{10} and H_{20} and the load p_0^H are determined according to the formulas:

$$\delta_{11}^w = 4\beta^2 nr; \quad \delta_{12}^w = \delta_{21}^w = -2\beta^2 nr; \quad (10.69)$$

$$\delta_{22}^w = 2\beta nr; \quad \Delta_{2p}^w = \gamma_2 H nr; \quad (10.70)$$

where $\gamma_2 = p_0^H/H$.

The total deformations at point A will be

$$E\varphi_A = 2nr\beta^2 \left[2\beta M_{10} - H_{20} + \frac{\gamma_1 \vec{C}_2}{4\beta^2 C_3^{(1)}} \right]; \quad (10.71)$$

$$E\xi_A = 2nr\beta \left[H_{20} - \beta M_{10} + \frac{\gamma_1 \vec{C}_2}{8\beta^2 C_3^{(1)}} + \frac{H}{2\beta} \left(\gamma_2 - \frac{\gamma_1}{2} \right) \right], \quad (10.72)$$

where $\gamma_2 - \gamma_1 = \frac{p_0^H + p_1^H}{2H}$; ξ is the displacement of unit A (in the direction H_{20}).

We calculate the expressions $\frac{\gamma_1}{4\beta^2} \cdot \frac{\vec{C}_2}{C_3^{(1)}}$ and $\left[\frac{\gamma_1 \vec{C}_2}{8\beta^2 C_3^{(1)}} + \frac{H}{2\beta} \left(\gamma_2 - \frac{\gamma_1}{2} \right) \right]$ for the geometrical data of tanks which can be used practically, in which the value $\beta H/2 = 2$ to 2.5. For this case, the coefficients are: $C_3^{(1)}$ = from 1.05 to 1.01; $C_2^{(1)}$ = 1.1 to 1.02; $\vec{C}_2 = 0.45$ to 0.20; $\vec{C}_3 = 0.1$ to (-0.03). Having substituted these data, we see that the expression $\frac{\gamma_1 \vec{C}_2}{2\beta^2 C_3^{(1)}} \approx 0$, and the expression $\left[\frac{\gamma_1 \vec{C}_2}{8\beta^2 C_3^{(1)}} + \frac{H}{2\beta} \left(\gamma_2 - \frac{\gamma_1}{2} \right) \right]$ differs from the expression $nr \left(\frac{p_0^H + p_1^H}{2} \right)$ by not more than 4 - 5%. This indicates that a change in the shape of the curve of T_{20}^H and, consequently, the load p_0^H and p_1^H in the upper half of the tank wall has almost no influence on the deformation of unit A and with satisfactory accuracy these deformations may be calculated starting from a rectangular curve of T_{20}^H with the base $(p_0^H + p_1^H)/2$ [see (10.10)].

Having determined $E\varphi_A$ and $E\xi_A$ according to (10.71) and (10.72), we formulate the canonical continuity equations of the deformations at point A

$$E\varphi_A - C_{00}^{AV} M_0 = 0; \quad (10.73)$$

$$E\epsilon_A - \delta_{20}^{\Delta} M_0 - \Delta b_{21}^{\Delta} = 0.$$

(10.74)

The continuity equations of the deformation in sections B and C are taken in accordance with the instructions given above for the case where the reinforcement is wound on the wall before the unit A is made monolithic. Usually, reinforcement is wound onto the wall

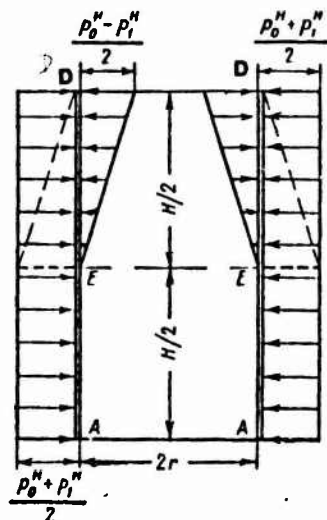

Fig. 10.9. Curve of the load from winding and separation of it into two components for calculated the unit D.

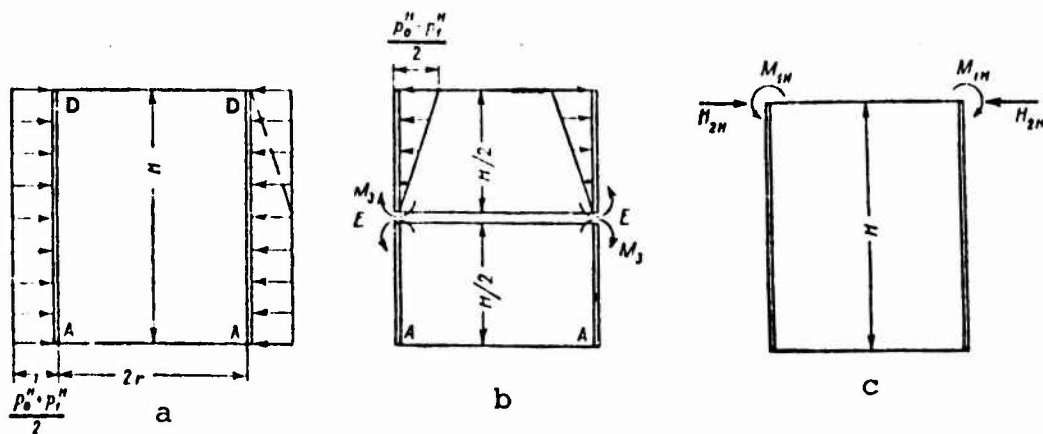

Fig. 10.10. Structural models for unit D.
a) first; b) second; c) model of extraneous unknowns.

before the upper unit of the tank wall is made monolithic, but if it is made monolithic before winding the reinforcement on the wall, it is necessary to determine M_{1H}^H and H_{2H}^H in unit D (Fig. 10.8).

Fig. 10.9 shows diagrams of separating the load from T_{20}^H for the top unit D and Fig. 10.10 -- structural models of a shell for calculating unit D.

For the first loading scheme

$$\Delta_{1p}^u = 0; \quad \delta_{11}^u = 4\beta^2 nr; \quad \delta_{22}^u = 2\beta nr; \quad \delta_{12}^u = \delta_{21}^u = -2\beta^2 nr; \quad \Delta_{1p}^u = nr \frac{p_0^H + p_1^H}{2};$$

For the second loading scheme

$$\delta_{12}^u = 4\beta^2 nr \vec{C}_3; \quad \Delta_{1p}^u = \gamma_1 r p; \quad \delta_{22}^u = 2\beta^2 nr \vec{C}_2; \quad \Delta_{1p}^u = -\gamma_1 H nr.$$

The continuity equations of the deformation in the unit will be

$$\delta_{11}^u M_{1H} - \delta_{12}^u H_{2H} + \delta_{13}^u M_3 + \delta_{11}^c M_{1H} + \Delta_{1p}^c + \Delta_{1p}^w = 0; \quad (10.75)$$

$$\delta_{22}^w H_{2H} - \delta_{21}^w M_{1H} + \Delta_{2p}^w + \delta_{23}^w M_3 = 0. \quad (10.76)$$

Having solved these equations, we determine M_{1H} and H_{2H} .

Having determined the extraneous unknowns M_{10} , H_{20} , M_{1H} and H_{2H} from (10.73) -- (10.76), by using (10.51) and (10.52) we are able to determine M_{1x}^H and T_{2x}^H .

The theoretical moments and annular stresses will be greater than their values from the load combinations: a) hydrostatic or ground pressure; b) from winding reinforcement onto the tank wall; c) from the influence of deformations of the bottom and cover when they are stressed.

Determining the Necessary Amount of Stressed Reinforcement

Carbon and high carbon cold-drawn steel (All-Union States Standard 7348-63 and All-Union State Standard 8480-63) with a standard

resistance R_a^H , equal respectively to 17,000 and 15,000 kgs/cm² (for wire with $d = 5$ mm) are used for reinforcement. The nominal theoretical resistance for this reinforcement is taken as 9500 and 8400 kgs/cm² respectively. The standard modulus of elasticity of the steel is $E_a^H = 1.8 \cdot 10^6$ kgs/cm². The controlled stress during winding for wire with $d = 5$ mm is taken as $\sigma_{ac} = -0.65R_a^H = 11,050$ kgs/cm² (All-Union State Standard 7348-63), which corresponds to a tractive force in one rod (coil) of $d = 5$ mm of $T = 2166$ kgs. In designing reinforcement, losses in stressing are calculated according to construction norm and regulation II.B-1-62. The sum of all losses σ_{an} usually is expressed as the value 1500 kgs/cm². The stress in ring reinforcement after all losses are manifested will be $\sigma_H = \sigma_{ac} - \sigma_{ap}$. The load carrying capacity of wound reinforcement from the strength condition will be

$$T_{car} = f_H \sigma_H. \quad (10.77)$$

From the condition of tank wall crack resistance the allowable stress in the reinforcement must be

$$T_{cr} \leq f_H (\sigma_{mmr} + 0.3), \quad (10.78)$$

where m_T is the work condition coefficient, equal to 0.9 (T_{cr} - in T; σ_V in T/cm²; f_H in cm²).

For determining the required amount of wound reinforcement, we take the smaller of the values T_{car} and T_{cr}

$$F_H = \frac{T_{20}^H}{T_{cr} \text{ (or } T_{car})} f_H, \quad (10.79)$$

where F_H is the total area of wound reinforcement per unit of length.

With a filled, but not dirt covered tank, the stress in the concrete of the wall will be

$$\sigma_b = \frac{T_{2x}^H - T_{2x}^{Pr}}{F_w}, \quad (10.80)$$

where F_w is the cross-sectional area of the wall; T_{2x}^{Pr} is the annular stress from the stored product.

The stress in the annular reinforcement after the tank is filled with the product is

$$\sigma_w' = \sigma_n + n\sigma_b, \quad (10.81)$$

where $n = E_a/E_b$.

It is convenient to formulate the selection of reinforcement cross sections in the form of a table.

Calculation of a Cylindrical Tank Wall for Temperature Influences

Reinforced concrete tanks designed for storing crude oil and various oil products are subjected to significant temperature influences. According to standard data, in making a calculation it is necessary to take account of the following temperature conditions of storage:

- crude oil from -10 to $+60^\circ\text{C}$;
- light oil products (benzene, kerosene) from -20 to $+40^\circ\text{C}$;
- residual oil (and heavy diesel fuels, close to it with respect to physical constants) from -5 to $+95^\circ\text{C}$.

Since crude oil enters large tank farms mainly through pipelines at a temperature significantly lower than $+60^\circ\text{C}$, tanks, basically designed for residual oil are calculated for temperature influences.

With the use of theoretical calculations and experimental data it has been determined that when a tank is filled with a product at a temperature of $90-95^\circ\text{C}$ the temperature drops Δt between the inner and outer surfaces of the tank and the average temperature t_{av} of the tank are:

- tank wall $\Delta t = 50$ to 60°C where $t_{av} = 65$ to 70°C ;
- tank bottom $\Delta t = 35$ to 40°C where $t_{av} = 65^\circ\text{C}$;
- base plate at support unit $\Delta t = 80^\circ\text{C}$ where $t_{av} = 55$ to 60°C ;
- ground temperature here was taken as 0°C .

Tanks for storing residual oil do not require a gas-tight cover and a tightly sealed bottom, therefore the bottom is assumed to be unstressed, the connection with the wall -- in a groove (third type), the cover unstressed, freely set on the tank wall.

Calculation of tank designs for temperature effects include determining the bending moments and annular stresses for the difference in deformations of the wall and bottom and separately from the temperature drop on the outer and inner surfaces. With an average temperature of the wall t_{av}^w and bottom t_{av}^{bot} the difference in deformations of the wall and bottom is

$$\Delta_{2t} = \alpha_{rr} E_b (t_{av}^s - t_{av}^d),$$

and taking account of frictional forces

$$\Delta_{2t} = \alpha_{rr} E_b (t_{av}^s - t_{av}^d) - \frac{p_0 \sigma_{rr}^2}{8\delta w}.$$

However, since there may be no displacement of the wall and bottom with respect to one another, a bending moment and shearing force, which are determined from the following equations, arise at their junction (unit A):

$$\delta_{11}^s M_{10}^t - \delta_{12}^s M_{20}^t - \delta_{10}^F M_0 = 0; \quad (10.82)$$

$$\delta_{22}^s M_{20}^t - \delta_{21}^s M_{10}^t - \Delta_{2t} - \delta_{20}^F M_0 = 0. \quad (10.83)$$

The values of the unit deformations are taken according to formulas (4.37) -- (4.41), (10.13) and (10.39); M_0 -- according to (10.15).

It is necessary to use equations (10.32) and (10.33) for comparing the equations of equality of deformations at point C (see Fig. 10.4). The value of the meridional moment M_{1x} is found according to formula (10.51). The bending moment in the tank wall from the temperature difference on the outer (t_2) and inner (t_1) surfaces is determined by

$$-M_1 - M_2 = \frac{E_b \delta^3 w \alpha_t \Delta t}{12(1-\mu)}, \quad (10.84)$$

where M_1 is the bending moment in the direction of the generatrix; M_2 - the annular moment.

From the moment M_1 where $t_1 > t_2$ compressive stresses arise on the inner surface, and stretching stresses on the outer surface. The moment is distributed uniformly along the length of the generatrix. However, if the shell has a free edge, then along it $M_1 = 0$. Consequently, in order to satisfy this condition, we must apply a uniformly distributed moment M_1 of the opposite sign along the ends.

Thus, the moment M_1 will act along the generatrix along the upper (free) edge, and the bending moments M_1 and M_{10} , determined by equations (10.82) and (10.83) will act in the support section (point A).

Calculation for temperature effects is performed for operating conditions, i.e., under the assumption that the tank is filled with heated product, and when it is covered with dirt.

In calculating for the temperature effects the modulus of elasticity is taken as 0.8 (where $t = 90^\circ\text{C}$). Crack opening to a width of 0.1 mm is allowed in calculating tank walls and bottoms taking account of temperature effects.

Determining the Ground Pressure at the Point Where the Tank Wall Rests on the Bottom and Calculation of the Bottom Plate at the Point of Column Support (Fig. 10.11)

The greatest ground pressure is developed on the rigid bottom section l_1 . As was shown, the moment M_0 and the normal force ΣP act on this section

$$\Sigma P = N + P + P_f + H_{40}, \quad (10.85)$$

where N is the pressure from the tank wall.

The area of the plate in sections $l_1 F_f = l_1 b_0$, where b_0 is the plate width, equal to 1 m.

The modulus of resistance of the base of plate l_1 is

$$W = \frac{b_0 l_1^3}{6} = \frac{l_1^3}{6}.$$

The ground load is

$$n_1^{gr} = \left[\frac{\sum P}{F_f} + \frac{M_0}{W} \right]; \quad n_2^{gr} = \left[\frac{\sum P}{F_f} - \frac{M_0}{W} \right]. \quad (10.86)$$

The values of n_1^{gr} and n_2^{gr} must not exceed the theoretical ground loads.

In the space between columns a reinforced concrete bottom plate experiences insignificant bending stresses and usually is reinforced for structural considerations (random overloads and standard requirements are considered). At the points where columns rest, the bottom plate usually has greater thickness. Since the columns transmit a great load to the bottom, bending moments and shearing forces arise in this section. From the condition of uniform load distribution on the thickened part of the plate, and from the condition of eliminating local stress concentrations, a round shape must be preferred for the column bases and the thickened part of the plate.

Prefabricated column bases, set on the bottom plate, must be of dimensions guaranteeing column stability during assembly. The thickened part of the plate with a comparatively small diameter (2 m) is of greater thickness (0.4 - 0.5 m) and therefore may be considered to be an absolutely rigid structure (stamp). The area of the thickened part of the plate is

$$F_f = \frac{N_0}{k_{gr}}; \quad N_0 = N_c + N_f + N_{pr} + N^{pl} \quad (10.87)$$

where N_c is the normal force of a column; N_f is the weight of the column base; N_{pr} is the weight of the product on the area F_f ; N_{pl} is the weight of the plate itself on the area F_f (diameter D).

A thin reinforced concrete bottom plate, which receives loading only from the product (p_0), is adjacent to the thickened part of the plate. The loads N_c , N_f and $(N_{pl} - N_{pl}^{bot})$, where N_{pl}^{bot} is the weight

of the part of the thickened plate of a thickness equal to the thickness of the thin bottom plate, act only on the thickened part of the

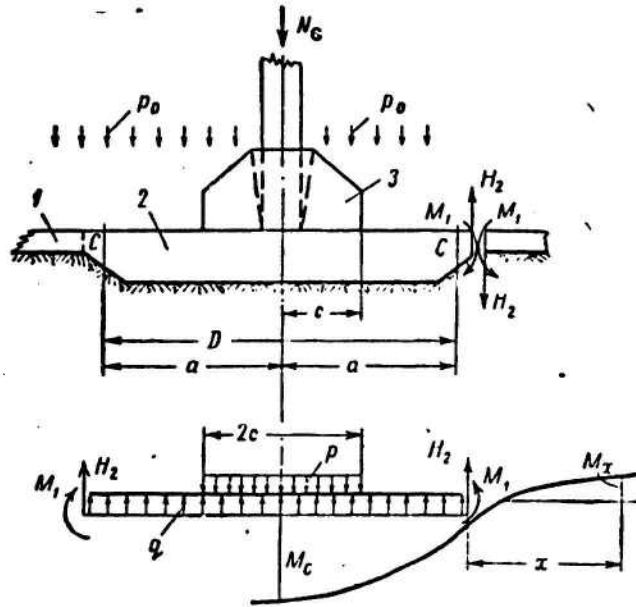

Fig. 10.11. Structural model and load on the bottom at the point where columns rest. 1 - bottom plate; 2 - thickened part of bottom plate; 3 - column base.

plate and, consequently, the moments M_1 and the shearing forces H_2 from the action of these forces arise at the junction of the thickened and thin parts of the plate (point C).

Having solved the canonical continuity equations of the deformations of point C (see Fig. 10.11), we determine the values of M_1 and H_2 . Since the thickened part of the plate is absolutely rigid, the angle of its rotation from the action of the symmetrical loads M_1 and H_2 is equal to 0.

At the forces N_0 and H_2 communicate to the plate only for settling δ_{22}^f (increased by E_b times).

$$\delta_{22}^f = \left[\frac{N_c + N_f + (N_{pl} - N_{pl}^d) - H_2 S_f}{F_f k} \right] E_b, \quad (10.88)$$

where S_f is the perimeter of the thickened part of the plate; the index "f" shows that the deformations refer to the thick part of the plate. For the adjacent thin part of the plate, correspondingly, we introduce the index "d".

Unit deformations of the thin part of the plate (at point C) lying on an elastic base and being infinitely long, will equal (increased by E_b times)

$$\delta_{11}^d = \frac{4\beta^3}{k} E_b; \quad \delta_{12}^d = \delta_{21}^d = \frac{2\beta^2}{k} E_b; \quad \delta_{22}^d = \frac{1}{2\beta^2 I_d}, \quad (10.89)$$

where $\beta = \sqrt[4]{\frac{k}{4E_b I_d}}$; k is the bed coefficient.

The continuity equations of the deformations at point C are

$$\delta_{11}^d M_1 + \delta_{12}^d H_2 = 0; \quad (10.90)$$

$$\delta_{22}^d H_2 + \delta_{21}^d M_1 - \delta_{22}^f = 0. \quad (10.91)$$

Having designated $[N_c + N_f + (N_{pl} - N_{pl}^d)] = N_0'$ and having substituted into equations (10.90) and (10.91) the values of the unit deformations, we obtain

$$M_1 \frac{4\beta^3 E_b}{k} + H_2 \frac{2\beta^2 E_b}{k} = 0; \quad (10.92)$$

$$M_1 \frac{2\beta^2 E_b}{k} + H_2 \frac{1}{2\beta^2 I_d} - \frac{N_0' E_b}{F_f k} + \frac{H_2 S_f E_b}{F_f k} = 0. \quad (10.93)$$

Having solved these equations, we determined M_1 and H_2 .

The curves of the moments in the thin part of the plate are determined by the formula

$$M_x^d = M_1 \varphi_{\beta x} - \frac{H_2}{\beta} \xi_{\beta x}. \quad (10.94)$$

The thickened part of a plate with radius a is under the influence of the following loads:

- on a circle of radius c from the forces N_c and N_f we designate this load as p ;
- on the entire area of the plate (with radius a) from the load $[N_{pr} - (N_{pl} - N_{pr})]$, we designate this load as q ;
- the contour forces M_1 and H_2 .

The load p acts from the top downward, the load q - from the bottom upwards. From these loads the greatest bending moments in the plate will be:

- from the load p

$$M_2 = +\frac{pc^2}{4} \left(1 + \frac{1}{m_1}\right) \left(\ln \frac{a}{c} + 0,85 - \frac{0,72}{4} \frac{c^2}{a^2}\right), \quad (10.95)$$

- from the load q

$$M_3 = -\frac{3 \left(1 + \frac{1}{m_1}\right) qa^2}{16}, \quad (10.96)$$

where $1/m_1$ is Poisson's ratio, equal to 0.167 for reinforced concrete.

The calculated moment is

$$M_0 = M_1 + M_2 + M_3. \quad (10.97)$$

For Calculating Cylindrical Reinforced Concrete Tank Covers

Usually columns in cylindrical tanks are arranged in concentric circles, the distance between them in the radial direction being 6 m.

The calculation of covers is in no way different from calculation of ordinary reinforced concrete structures with or without prestressing.

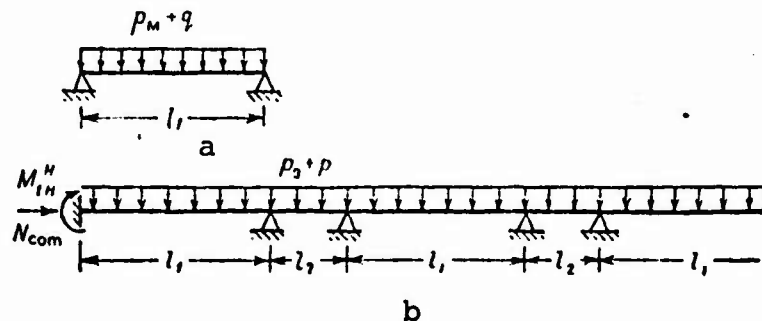

Fig. 10.12. Structural model of a tank cover.
a - before compression; b - after compression.

It is necessary only to mention a few features of the calculation of a cover in the case of its compression with ring reinforcement (in tanks for crude oil). In this case, it is useful to make the plate covers in the form of strips (ribless) with prestressed reinforcement.

From a calculation of the appearance of compressive stresses in the plates, the precompression of the cover as a whole, including the seams, is taken as 20 - 25 kgs/cm². The number of required turns of stressed ring reinforcement is determined according to the annular compression stress obtained. Since the construction of the given cover is designed for a water screen, it must be completely crack-resistant including the seams between the plates.

Flat prestressed plates of a compressed cover work in two ways:

1) before compressing the cover to the assembly load p_a and its own weight q (Fig. 10.12, a);

2) after filling the seams between the plates and after annular compression (Fig. 10.12, b) to the weight of the water screen p_s and the temporary load p as uncut structures.

The span l_1 is assumed to be equal to the distance of the space between supports plus δ_{p1} , the span l_2 is equal to the width of the beam minus δ_{p1} .

Strength of materials formulas are used for the calculation. The plates must be calculated for the appearance of cracks; particular attention must be given to the crack-resistance of the ring seam, which may occur (considering that the beams are straight) on a support or in the span l_2 . The theoretical loads are taken according to the data in §1, Chapter 10. In calculating a plate as an uncut structure, it is necessary to consider the support moment in the extreme unit (M_{1H}) from the following loads:

a) hydrostatic load and ground pressure on the tank wall [formulas (10.49), (10.50)];

determined by strength of materials formulas. The unit motions of the wall will be (increased by E_b times):

$$\text{from } M_{10} = 1 \quad \delta_{11}^s = \frac{1}{3I_w}, \quad (10.98)$$

from the action of hydrostatic loading (p_0 and p_1)

$$\delta_{1p}^s = - \left[\frac{p_1 H^3}{24} + \frac{8(p_0 - p_1) H^3}{360} \right] \frac{1}{I_w}. \quad (10.99)$$

In our structural model $H_{20} = R_A = \frac{H}{6} (p_1 + 2p_0) + \frac{M_{10}}{H}$, i.e., it is equal to the reaction of the wall from horizontal hydrostatic loading in unit A.

The continuity equation of the deformations in unit A will be

$$\delta_{11}^s M_{10} - \delta_{00}^s M_0 - \delta_{1p}^s = 0. \quad (10.100)$$

In this equation M_0 is expressed by $M_{10} (H_{20} = R_A)$ according to the specifications for the third type of bottom [formulas (10.32), (10.33)]. Having solved (10.100), we determine the M_{10} sought.

The curve of the moments in the tank wall is determined by the usual strength of materials formulas. In calculating a tank for ground pressure it is necessary to use $p_0 = -q_0$ and $p_1 = -q_1$ in (10.99).

Calculation of Rectangular Tanks for Temperature Effects

In the case of filling a rectangular tank with a hot product, the average temperatures of the wall and bottom are assumed to be the same as for cylindrical tanks. If the average temperature of the bottom is t_{av}^{bot} , the deformation (displacement) of the bottom at point A (Fig.

10.14) will be

$$\delta_{2t}^d = \alpha_t t_{av}^d E_b \frac{b}{2}, \quad (10.101)$$

and, taking account of the friction of the bottom against the ground

$$\delta_{2t}^d = \alpha_t t_{av}^d E_b \frac{b}{2} - \frac{p_0 \eta b^2}{8\delta_d}, \quad (10.102)$$

where φ is the coefficient of friction; p_0 is the pressure of the product; δ_{bot} is the thickness of the bottom; b is the width of the tank.

The angle of rotation of the wall is

$$\delta_{1t}^s = \frac{\delta_{1t}^d}{H}, \quad (10.103)$$

where H is the height of the wall.

The moment M_{10}^t in unit A is determined from the equation

$$M_{10}^t \delta_{11}^s + M_{00} \delta_{00}^F + \delta_{1t}^s = 0. \quad (10.104)$$

The calculation given refers to a cross section of the wall at a certain distance from the corner of the tank. The tank corners are particularly stressed, which often leads to the formation of cracks in them.

A bending moment (see §3 of this chapter) arises from non-uniform heating in the tank wall. If the temperature drop between inner and outer wall surfaces is $\Delta t^w = t_{\text{in}}^w - t_{\text{h}}^w$,

$$M_1^t = \frac{E_b \delta_{10}^2 \alpha_t \Delta t}{12(1-\mu)}. \quad (10.105)$$

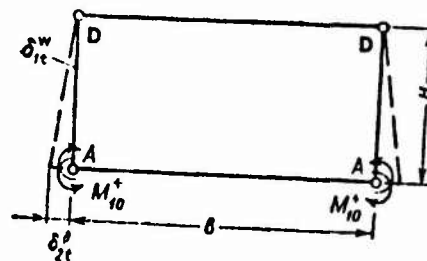

Fig. 10.14. Structural model of a rectangular tank for temperature effects.

Stretching stresses arise on the outer wall surface from the moment M_1 . As a result, the bending moment

$$M_A^t = M_1^t + M_{10}^t. \quad (10.106)$$

arises in the support section of the wall (A) from temperature effects.

The temperature effects on a tank are considered under working conditions, i.e., with the tank filled with product and covered with dirt.

Calculation of the bottom of rectangular tanks at the points where columns rest is performed the same as in the case of cylindrical tanks (see §3).

The covers of rectangular tanks are made from standard prefabricated reinforced concrete elements. Considering the increased load on the cover (dirt covering, temporary loads), the prefabricated reinforced concrete elements of a cover are taken from catalogs intended for multi-stage commercial buildings.

§5. Formulas for the Direct Determination of the Bending Moments and Shearing Forces in a Tank Wall Support Unit

If in a bottom of the third type (junction in a groove) $l_1 = 1.5$ to 2.0 m, then for determining M_{10} and H_{20} it is possible to use the following formulas (where $k = 5 \cdot 10^3$ t/m³).

Cylindrical Tanks

With hydrostatic loading p_0 and the effects of the force N

$$M_{10} = \frac{p_0 n r^2 (1.3 \sqrt{n} - 0.9r) + 11.4 p_0 r^2 - N r (21 \sqrt{n} + 80r)}{4.6 \delta_w^2 \sqrt{n} + 410r^2}; \quad (10.107)$$

$$H_{20} = \frac{3.4n^2 M_{10} - 16.2rN + p_0 n r^2}{2.62rn \sqrt{n}}. \quad (10.108)$$

In formulas (10.107) and (10.108) the force N is calculated only from the temporary load and the load from the dirt cover on the top of the tank. The loads from the weight of the wall itself and the cover act before the support unit is made monolithic and, consequently, do not cause the appearance of the moment M_{10} in section A.

With the loading from ground pressure ($N = 0$ and $p_0 = 0$)

$$M_{10} = \frac{q_0 n r^2 (0,85c - 1,3 \sqrt{n}) - 70r \sqrt{n}}{4,6n^2 \sqrt{n} + 410r^2}; \quad (10.109)$$

$$H_{20} = \frac{3,4n^2 M_{10} - nr^2 q_0 - 54r}{2,62rn \sqrt{n}}. \quad (10.110)$$

Rectangular Tanks.

From the hydrostatic load p_0 and the force N

$$M_{10} = \frac{p_0 H_w^2}{15 (H_w + 1200 k_1 \delta_w^2)}, \quad (10.111)$$

where H_w is the height of the tank wall; δ_w is the thickness of the wall; k_1 equals $\frac{1}{l_1^2 (1+L)}$; $L = \frac{2,28 l_1^2 + 2,44 l_1 + 1,30}{l_1^2}$.

§6. Determining the Unit Deformations, Meridional Moments and Annular Stresses in a Tank Wall with Thickness Varying According to Height (Fig. 10.15)

Walls of variable thickness are used for large capacity tanks (30,000 m³ and more), when the height of the tanks exceeds 10 m, and the diameter 60 - 80 m.

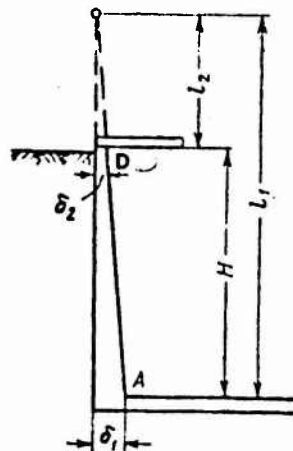

Fig. 10.15. Tank wall of variable thickness.

We designate l_1 - the distance from the bottom of the wall to the point of intersection of the side faces of the wall; l_2 - the same, from the top of the wall; δ_1 the thickness of the wall downwards (point A); δ_2 the thickness of the wall upwards (point B); k_1 and k_2 - the coefficients:

$$k_1 = \frac{1,3l}{\delta_1 \sqrt{n_1}}; \quad k_2 = \frac{1,3l}{\delta_2 \sqrt{n_2}};$$

where $n_1 = r_0/\delta_1$; $n_2 = r_2/\delta_2$; r_0 is the mean radius of the wall.

The unit deformations of a wall of variable thickness may be determined according to the formulas given below, where δ^w are the unit deformations of a wall of constant thickness (for unit A of thickness δ_1 , for unit D of thickness δ_2); δ' are the deformations of a wall of variable thickness.

For the lower unit (section A)

$$\delta'_{11} = \delta_{11}^w \frac{k_1 l_1}{(l_1 k_1 - 1,25)}; \quad (10.112)$$

$$\delta'_{21} = \delta'_{12} = \left(\frac{k_1 l_1}{k_1 l_1 - 1,25} \right) \delta'_{11}; \quad (10.113)$$

$$\delta'_{22} = \delta_{22}^w \left(\frac{k_1 l_1 - 0,25}{k_1 l_1 - 1,25} \right). \quad (10.114)$$

The load terms of the equations from hydrostatic loading are

$$\delta'_{1p} = + \delta_{1p}^w \frac{\left(p_0 \frac{\delta_2}{\delta_1} - p_1 \right)}{p_0 - p_1}; \quad (10.115)$$

$$\delta'_{2p} = \delta_{2p}^w = + \frac{p_0 r^2}{\delta_{cr}}; \quad \delta_w = \delta_1. \quad (10.116)$$

For the upper unit (section D)

$$\delta'_{11} = \delta_{11}^w \left(\frac{k_2 l_2}{k_2 l_2 + 1,25} \right); \quad (10.117)$$

$$\delta'_{12} = \delta'_{21} = \left(\frac{k_2 l_2}{k_2 l_2 + 1,25} \right) \delta'_{11}; \quad (10.118)$$

$$\delta'_{22} = \delta_{22}^w \left(\frac{k_2 l_2 + 0,25}{k_2 l_2 + 1,25} \right). \quad (10.119)$$

The load terms of the equations from hydrostatic loading are

$$\delta_{1p}' = \delta_{1p}^w \left(\frac{-P_1 + P_0 \frac{\delta_2}{\delta_1}}{P_0 - P_1} \right); \quad (10.120)$$

$$\delta_{2p}' = \frac{P_1 r^2}{\delta_w}; \quad \delta_w = \delta_2. \quad (10.121)$$

After the extraneous unknowns M_{10} , H_{20} , M_{1H} and H_{2H} are determined, the meridional moments according to the height of the tank wall are found according to formulas (10.51) -- (10.54). The empirical formulas proposed by Prof. V. A. Bushkov, give more accurate results for the annular stresses in the given case.

For the bottom unit (A)

$$T_{2x} = T_{20} + 4rk_1^2 [M_{10} \delta_{10}' \zeta_{\beta x} - (M_{10} \delta_{10}' + H_{20} \delta_{20}') \theta_{\beta x}]. \quad (10.122)$$

For the upper unit (D)

$$T_{2x} = T_{20} + 4rk_2^2 [M_{1H} \delta_{1H}' \zeta_{\beta x} - (M_{1H} \delta_{1H}' + H_{2H} \delta_{2H}') \theta_{\beta x}]. \quad (10.123)$$

The influence of the change in wall thickness with height on the value of the extraneous unknowns is comparatively small, and in practical calculations the unit motions often are assumed to be the same as for a wall of constant thickness: for the bottom edge (A) - δ_1 and for the top (D) - δ_2 .

Chapter Eleven

THE TECHNOLOGY OF MAKING AND ASSEMBLING REINFORCED CONCRETE TANKS

§1. Materials

The concrete for reinforced concrete tanks must have the following properties:

- a) Product impermeability (for crude oil and heavy oil products);
- b) Resistance in an aggressive medium;
- c) High density, providing reliable protection of the steel reinforcement from the action of aggressive medium.

The aggressiveness of crude oil and oil products toward concrete is determined by the presence in them of sulphur compounds, which with the potassium hydroaluminates, contained in the cement, form potassium hydrosulfoaluminates. The latter have a destructive effect on concrete (they have a greater volume than the original compounds). Therefore only sulfate resistant Portland cements are used for preparing the concretes for constructing reinforced concrete tanks. If low and medium aluminate Portland cements are used, additives in the form of soluble glass are introduced into the concrete.

At the present time special concrete with the addition of soluble glass is the basic material for constructing reinforced concrete tanks in our country.

Low and medium aluminate cements are characterized by the following aluminate content: $C_3A \leq 8\%$; $C_3A + C_4AF \leq 22\%$. The activity of the cement must be not lower than 400 kgf/cm (All Union State Standard 10178-62). The thickness of the grout must not exceed 0.28 in order that the concrete be impermeable and that settling cracks not appear in it.

V. E. Lyrich, V. Kh. Prokhorov and I. B. Veprik created an expanding cement (Inter-Republic Technical Specifications 51-118-66), highly resistant with respect to crude oil and residual oil and well protecting reinforcement from corrosion.

Experimental models of monolithic reinforced concrete tanks of low aluminate cements with the addition of iron oxide hydrates, obtained electrically, to the concrete mixture were constructed. The batching of the additive was 1.5% of the weight of the cement, calculated for the iron contained in the additive (the proposal of Prof. Kozyrov). The additive was introduced into the water before hardening of the concrete mixture. Test tanks (up to 2000 m³ in capacity) without facing were filled with benzene and showed good results. These tanks are absolutely crack resistant (prestressed). At the present time 100 -- 200 m³ tanks for storing light oil products (buried type) may be constructed from special concretes with the addition of iron oxide hydrates.

The density of concrete depends on the water-cement ratio. In concretes intended for tank construction, in which crude oil and residual oils are to be stored, the density must not exceed 0.45 -- 0.50. The standards for the selection of materials and initial parameters for calculating concrete compositions are found in the "Specifications for Designing Anti-Corrosion Protection of Structural Elements of Industrial Buildings Where Aggressive Media Are Used (SN 262-67)."

The cement used at factories making tank elements of reinforced concrete must have a manufacturers certificate and, if it is more than three months old, must be repeatedly tested according to the method given in All-Union States Standard 310-60.

The plants supplying the cement are required to report the calculated mineralogical composition of the cement for each batch upon the customer's request. Cements intended for reinforced concrete tanks must not be mixed with cements for constructing other structures during storage.

The following requirements are imposed on the concrete aggregates (sand, gravel).

According to All-Union States Standard 8736-67 the sand must contain no more than 2.0% (by weight) of washable particles and no more than 1% clay. The granulometric composition of the sand must correspond to the data in Table 11.1.

Table 11.1

Diameter of screen openings, mm	Must pass sand, per cent by weight	Diameter of screen openings, mm	Must pass sand, per cent by weight
5.0	85-100	0.6	20-65
2.5	60-100	0.3	10-50
1.2	35-75	0.15	0-20

For sand blasting and gunite work, the sand must have a fineness modulus of more than 1.7 and particle diameters not over 3 mm.

The moisture content of sand intended for gunite work with use of powdered cement must be no more than 5%.

Hard igneous rock and dense limestone gravel and rubble are used as coarse aggregates for concrete, but rubble is preferred because of its better adhesion with the cement solution in the presence of larger paths for the filtration of liquid in the structure of the concrete.

Course aggregates for special concretes should meet the requirements of the corresponding standards and SNiP I-B.1-62.

The mechanical and physical properties of a course aggregate should satisfy the following requirements:

- Compression in the water-saturated state of the rock subjected to fracturing for rubble Not less than 2 times higher than the concrete grade
- Content of weak rock grains Not more than 10% for artificial rock and igneous rock and not more than 15% for sedimentary rock.

Coarse aggregate must satisfy the requirements of All-Union State Standard 4797-69 with respect to granulometric composition.

Water containing not more than 2700 mg/l of sulfates with a total salt content of 5000 mg/l is used for preparing concretes and pouring them. The pH of the water must be no less than 4. Drinking water may be used without impurity analysis.

A solution composition of 1:2 (cement to sand) is used for gunniting tank wall surfaces. Soluble glass in an amount of 3.5% of the cement weight usually is added to the gunite solution applied to the inner surface of the tank wall; liquid glass is added preliminarily to the mixing water.

The reinforcement steel used in constructing reinforced concrete tanks must correspond to the requirements of CN and R I-C.4-62 and III-C.1-62. Reinforcing steels of classes A.IV and A.IIIC are used in tank walls and covers. Class A.IIIC steel is subjected to hardening with prestretching. Indented high strength wire not more than 5 mm in diameter (All-Union State Standard 8480-63) is used for stressed ring reinforcement. Before winding, high strength wire (samples from each

batch) is tested for breaking and bending (CN and R III-C.1-62 and IC.4-62). Steel cable wire 0.8 -- 1.2 mm in diameter is used for splicing stressed reinforcement (All-Union State Standard 1071-67, All-Union State Standard 9389-60 Class III or All-Union State Standard 7372-66).

In constructing tanks it is necessary to have the following data for determining concrete composition:

- a) The degree of concrete density determined by the degree of aggressiveness of the product to be stored in relation to the cement chosen (water:cement ratio);
- b) The calculated hardness of the concrete (grade) at the given period;
- c) The given mobility of the concrete mixture, which is determined by the settling of a standard cone for semiplastic and plastic concrete mixtures and according to Prof. B. G. Skramtayev's method for a rigid concrete mixture;
- d) The maximum allowable coarseness of the rubble or gravel for the given construction;
- e) The results of cement tests: activity, bulk weight in the loose dry state and the correspondence to the requirements of the State Standard;
- f) The results of sand tests (bulk weight in the loose dry state, specific gravity, coarseness and moisture);
- g) The results of testing the gravel or rubble (bulk weight in the dry state, specific gravity, maximum coarseness D_{max}).

The components of the concrete for a test mix are calculated and batched for aggregates in the air-dry state. The hygroscopic moisture of the aggregates is not considered in determining the water-cement ratio.

§2. The Manufacture of Prefabricated Reinforced Concrete Tank Parts

Prefabricated reinforced concrete parts for oil tanks must be

manufactured in continuous operation plants according to techniques providing for obtaining products of the necessary quality. Sometimes the simplest structures (footings, columns, heads) may be made on temporary casting yards or on-site areas. The principle parts for tanks are made only in steel forms and for small parts (footings, column heads) wooden forms, wrapped with roofing tin, may be used.

The concrete mixture for tank parts is prepared in forced action cement mixers. The mixing time for a concrete mixture with the addition of soluble glass is somewhat greater than for concrete without add mixtures (Table 11.2).

Table 11.2

Type of cement mixer	Volume of cement mixer, l	Mixing time, min
Free fall.....	250-425	2.5
	1000-1200	3.0
Forced mixing.....	500	2.0
	1000	3.5

The time from the beginning of preparing each batch of a concrete mixture with the addition of soluble glass before pouring usually does not exceed 45 minutes.

The planned position of reinforcement meshes and frames in tank parts is marked with concrete spacers. The use of steel "frogs" and "spiders" for fixing the position of the reinforcement is not allowed. The size of the rubble or gravel must not exceed 1/4 of the smallest dimension of the part.

Stiff concrete mixtures yielding the required concrete density upon compacting are used for prefabricated parts of reinforced concrete tanks. With the use of hand, platform or deep vibrators the concrete mixture must have a standard cone settling of 1 - 2 cm.

The area of application of hand vibrators and the compacting time required with their use are presented in Table 11.3.

Table 11.3

Type of vibrator	Consistency of concrete mix, cm	Area of application	Thickness of layer poured, cm	Radius of action or spacing, cm	Compacting time, s
Platform	1 - 2 and more	Flat panels, plates, ribbed plates	10-12	Length of working part of platform minus 5 cm	25-40
Internal	1 - 2 and more	Foundations, columns, beams, panel ribs	20-50	24-50	20
Bar vibrators and rack vibrators	3 and more	Tank bottoms, wall panels	Leveling the surface layer of concrete	—	30

Tank wall panels are formed with the outer surface upwards. If the outer surface is formed downwards, toward the bottom plate, the concrete surface obtained is smooth and the required adhesion of the gunite solution applied for protecting the ring reinforcement cannot be obtained with it. The convexity of the outer surface of the panel is achieved with the use of sliding stamp vibrators or rack vibrators of the appropriate curvilinear configuration.

In panels with brackets, the ends of the rods of the stressed reinforcement (longitudinal) are cut first on the side of the bracket, and then on the side of the opposite end of the part.

In cover plates of trapezoidal form in the plane the ends of the stressed reinforcements are cut first from the wide end of the plate.

In order to provide accuracy of assembly of prefabricated elements of tanks, certain tolerances are adhered to during manufacture (Table 11.4).

Table 11.4

Part	Deviation, mm					Warping according to length	
	Length	Width	Thickness or height	Distance from bottom plate to axis of stressed reinforcement	Distance between bearing surfaces of supports	With length up to 6 m	With length over 6 m
Footings for columns	±7.5	±7.5	±5.0	-	-	-	-
Internal dimensions of casings	±10.0	±10.0	±10.0	-	-	-	-
Thickness of casing bottom	-	-	-10.0	-	-	-	-
Columns	-5.0	±2.5	±2.5	-	-	5.0	7.5
Beams	-5.0	±2.5	±2.5	+0	+1.0	5.0	7.5
Cover plates	-5.0	±2.5	±2.5	-5	-5.0	2.5	5.0
				+0	+1.0		
Wall panels	-7.0	±2.5	±2.5	-5	-5	5.0	7.5
				+0	+1.5		
				-5	-1.0		

Heat treatment in rooms with the aid of steam is used in factories to speed hardening of parts.

The following optimum conditions for heat treatment of reinforced concrete parts, made of special concrete with the addition of soluble glass, is used:

Rate of heatingNot more than 20°C for 1 hour
 Temperature of isothermal warmup..70 - 80°C

During heat treatment the free surfaces of the parts are covered with watertight material (polymer films, rubber), which inhibits the evaporation of moisture from the concrete and raises its mechanical properties.

§3. Technology of Building Prefabricated Reinforced Concrete Tanks

The construction and assembly operations in building reinforced concrete tanks are performed observing the safety and fire prevention

regulations in effect. All construction and assembly operations are performed in accordance with the plans for the organization of construction and performance of operation.

Since tanks basically are built according to standard plans, it is sufficient only to correct them with regard to the peculiarities of tank connections and local construction conditions. In building large tank farms it is necessary to work out a construction grid graph which is a part of the construction grid graph of the entire complex of structures on the site.

Preparatory Work

Before beginning the basic work of building tanks on the construction site the following preparatory operations are performed: the geodetic basis is transferred to the construction site (the axes are pegged out); the site is provided with water and electricity; temporary access roads for trucks are built; temporary roads into the excavation for a group of tanks must provide entrance into the excavation at no less than 2 points; temporary buildings are constructed (electrical stations, compressor stations, etc); the excavations are protected from surface water getting into them.

In all cases, where it is possible, permanent roads, power supply systems and water lines are used for construction.

Geodetic Operations

Before beginning work, the boundaries of the excavations, the entrances to them, the sections for dumping dirt and the arrangement of tank axes are pegged out. In constructing cylindrical tanks, a central surveying post, which is the base for the subsequent operations of pegging out and checking level marks, is set out.

The basic surveying operations include:

a) compiling a master system of level marks on top of the foundation along the ends of the foundation under the tank bottoms;

b) accurately pegging out the base part of the bottom (the groove in the case of a bottom of the third type and the base plates in the case of the fourth type of bottom);

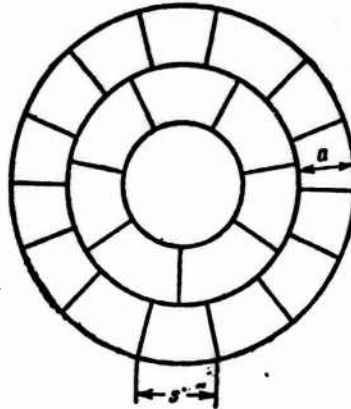

Fig. 11.1. Plan of seams in cylindrical tank bottoms
($s = a =$ from 15 to 20 m).

c) laying out (along the footing) the places where deformation seams are to be located (according to plan) (Fig. 11.1), setting and levelling the seam form (top edges of boards);

d) compiling a master system of level marks of the bottom and ring-shaped base after pouring the bottom;

e) accurately laying out the axes of the column bases on the bottom, checking the level of the bottom of the foundation casings, determining the thickness of the concrete for setting the columns;

f) checking the plumb of the columns with an instrument;

g) laying out circles, corresponding to the outer edges of the panels, and drawing figures determining the position of the panels and the joints between them, on the foundation part of the bottom (in the groove or on the base plates).

In the case of a bottom of the third type, water is poured into the groove up to the level of the bottom of the wall panels and marks, according to which the concrete is poured, are made on the wall of the groove. In the case of a bottom of the fourth type, the base (prefabricated) plates are set according to the marks. The plumb of the wall panels is checked with a theodolite.

§4. Earth Moving Operations

Usually, one common excavation is dug for a group of 4 - 8 tanks. The amount of excavation for building buried reinforced concrete tanks is great. For example, in the case of constructing 30,000 m³ tanks, an excavation for 8 tanks has a volume of around 250,000 m³.

Large excavations are surrounded with high walled ditches to keep surface water from getting into them and the water is drained to low places.

The topsoil is removed with a bulldozer, piled in separate heaps, and later is used for covering the tanks with dirt and for sowing grass. The rest of the digging is performed with excavators and the dirt is transported in dumptrucks. The entrances to the excavation are made no less than 4 m wide with a slope of no more than 45%. The base under the bottom of the tank must not be disturbed and therefore the excavators leave 20 cm of dirt above the planned grade. This excess is removed which graders or specially equipped bulldozers which permit dirt removal to be performed correct within 5 cm. Final grading is performed manually.

Allowance is given for the winding machines and assembly crane in determining the bottom dimensions of excavations.

The bottom of an excavation is sloped toward the center for the removal of rain water and ditches and drainage pits are dug for pumping water out. The finished excavation is certified, checking the elevation marks and dimensions in accordance with the plan. If it is necessary to build up the base, this is done with sandy-gravelly soil compacted in layers.

§5. Pouring the Footing and Reinforced Concrete Bottoms

Before the footing is poured, the dirt base must be moist in order to eliminate the possibility of the dirt deforming if it is frozen or dried. Before the footing is poured, a form is put under

the access pits and the receiving-distributing and cleaning pipes are laid and unfastened. If the tanks are of large capacity, the footing is poured in strips, arranged parallel to the axis of a cylindrical tank or parallel to the side of a rectangular tank. The width of the strips is chosen depending on the length of the rack vibrator (4 - 6 m). The boundaries of the strips are fixed with batter boards, fastened with pegs. Every other strip is poured (Fig. 11.2). The rack vibrators rest on the batter boards. The

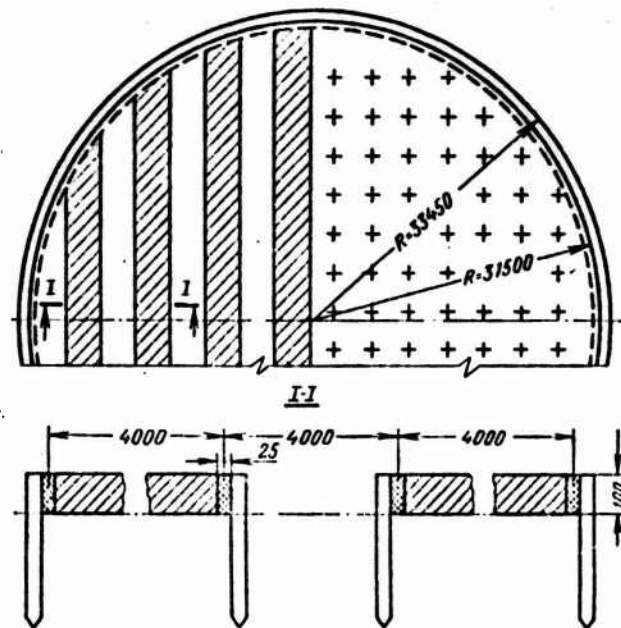

Fig. 11.2. Pouring the footing under the bottom of a 30,000 m³ tank.

intermediate strips are poured after the concrete in the previously poured strips acquires the necessary hardness and the batter boards and pegs are removed before the intermediate strips are poured. The settling of a cone of the concrete mix must be 4 - 6 cm.

The poured footing is covered with a waterproof layer (rubberoid or asphalt), and common, in the case of a stressed bottom, also a sand slip layer. Before the bottom is poured the latter is covered with a layer of parchment. The sand slip layer must be dry. If according to the conditions for pouring the bottom concrete trucks must drive onto the footing, special roads of reinforced concrete road

plates, laid on a said layer (25 - 40 cm) are laid out for them.

In accepting a base before pouring the footing, the following deviations from the plan, determined by levelling, are allowed: the bottom from a horizontal surface in the entire area ± 50 mm, difference in levels of points over 5 m -- 20 mm.

Pouring the Bottom

The form for the foundation part of the bottom (at the point where wall panels rest) and, in the case of a stressed bottom, the form for the seams according to the plan, are set on the poured footing. In the case of a stressed bottom, the seams are not reinforced, and in the case of an unstressed bottom, the seams are made without a form (since the reinforcement passes through them) and their quality is worse than the seams made with a form. The form for pouring the foundation part of the bottom is reinforced against shifts during pouring and vibrating.

When pouring the bottom, the thickness of the protective layer must be watched carefully. The planned position of the reinforcement is fixed with concrete pads.

Bottoms are poured either in rectangular strips (in rectangular tanks), or in rings (in cylindrical tanks). The width of the strips or rings is chosen so that the next strip is poured before the concrete in the previous strip sets.

When the bottom is poured, the concrete is delivered in dump trucks (using temporary roads) or by bucket and a crane. The latter method gives better results, since it allows the concrete to be poured more uniformly, but it is more expensive.

Grade 200 - 300 concrete is used for tank bottoms. The thickness of the bottom plate is 10 - 15 cm, and the settling of a cone of the concrete mix is 2 - 4 cm. The concrete mix laid in the bottom

is compacted carefully with deep and platform vibrators. The surface of the bottom is smoothed with rack vibrators. The concrete laid in the bottom is covered with water for no less than 7 days (every 3 - 4 hours during the day and once at night). The bottom grooves and pits are filled with water every 10 hours after the concrete is poured.

The bottom is poured according to a plan taking account of the following: the hidden work (reinforcements); quality of the concrete (according to laboratory cube tests); the correspondence of the dimensions and levels to the plan; the absence of cracks, potholes and cavities. Deviations of no more than ± 10 mm are allowed in the levels of the surfaces serving as supports of the columns and wall panels, a difference in the levels of points of 20 mm over 5 m is allowed and deviations in the cross-sectional dimensions of elements of the bottom of $+10 - 5$ mm are allowed.

§6. Assembly of Prefabricated Reinforced Concrete Tank Parts

Reinforced concrete tanks usually are constructed in groups (storage tank farms for petrochemical complexes, large transshipping tank farms, etc.). In this case, it is expedient to use diesel caterpillar cranes, which have great maneuverability, do not require rails, and electrical supply, for assembling tanks. One powerful crane (with a lifting capacity of 20 ton-force) is sufficient for assembling a whole group of tanks on a site, and a crane with a load lifting capacity of 5 - 75 ton-force is sufficient for assembling the small parts and rigging and handling concrete buckets. In drawing up a detailed plan for the order of assembly, it is necessary to indicate precisely the position of the crane and to list the prefabricated parts which the crane is to assemble from a given position.

Large capacity tanks occupy a large area (for example, a 30,000 m³ tank occupies an area of approximately 4500 m²) and it is practically impossible to perform all assembly operations without the crane driving onto the bottom. In this case, three or four temporary roads, which are made of road plates laid over sand, are provided for in the assembly plan. The crane sites are arranged on these temporary roads

(Fig. 11.3). However, in the case of cylindrical tanks, this proves to be insufficient, and the central part of the bottom (with a diameter

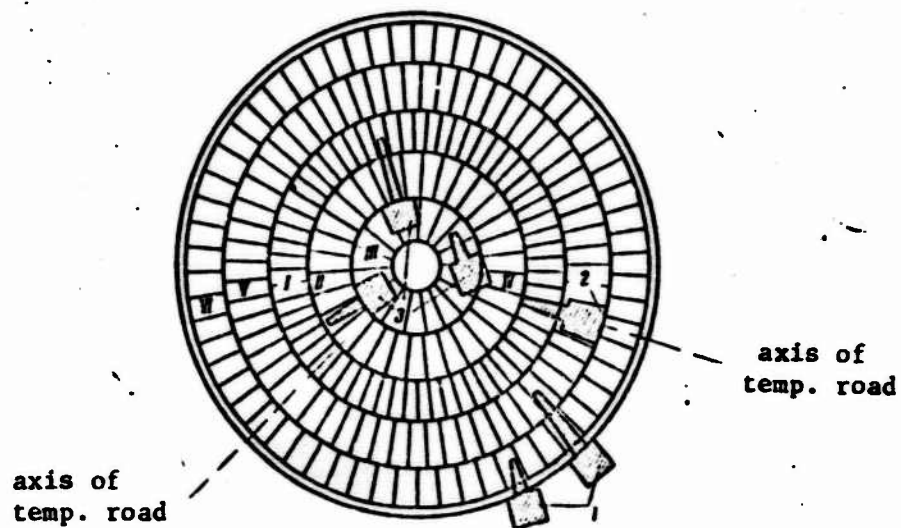

Fig. 11.3. Order of assembly of prefabricated parts of a 30,000 m³ tank. I-VI - assembly sequence; 1- crane positions outside of bottom; 2 - crane exit path; 3 - crane positions in central (reinforced) area of bottom.

of ~18 m) is reinforced, calculating for the load of a heavy crane. A crane moving in this area is in the position to assembly most of the tank. Cylindrical tanks are assembled in rings, and rectangular tanks are assembled in strips (the crane retreats and assembles around itself). The temporary crane roads are filled in in the last pass, when the crane retreats to the exit from the tank. Then the reinforced concrete plates of the temporary roads are removed.

In large capacity tanks the two outer rings (VI and V, see Fig. 11.3) and wall panels are assembled with the crane standing outside the tank. Therefore, additional width is provided so that the crane and trucks with the prefabricated parts can move around the tank. For example, in assembling a 30,000 m³ tank with a 20 ton E-1254 Caterpillar crane, it is necessary to have a distance of 9 m between the tank wall and the edge of the excavation.

Prefabricated reinforced concrete parts must be assembled in one piece, without the use of intermediate units. The bottom concrete must be at no less than 70% of the planned hardness when the crane

is driven onto it. The column bases having been set in a sand-cement mortar, a cement-sand mixture is poured into the foundation casings so that the casing bottoms come up to the level of the column bottoms. The surveyor monitors this operation. As the columns are assembled, they are temporarily fastened in the foundation casings with steel wedges. To provide stability, it is recommended that after assembling 3 or 4 columns elements of the cover (beams and plates) connected by welding, be laid on them. The columns are cemented into the foundation casings with grade 200 concrete vibrated with the vibrators. Columns are cemented in groups, so that they will be stable after wedges are removed. The next group is cemented in after the joints reach a hardness 50 kg/cm^2 .

Staging raised on forklifts for movable ladders are used so that the welders can work normally.

If a tank is constructed with the third type of bottom (with a groove), the wall panels are fastened in the groove with steel wedges, and if the bottom is prestressed the panels are fastened with standard braces.

In rectangular tanks it is necessary to fasten each panel and in cylindrical tanks it is sufficient to fasten every 4 - 5 panels. After a panel is set, the projecting ends of its reinforcement are welded quickly to the projecting ends of the preceding panel.

Wall panels are assembled simultaneously with the assembly of the cover plates of the VI strip (Fig. 11.3), which provides for stability against wind load and makes it possible to do without standard panel braces. In rectangular tanks, where the wall panels are laid out in line with the cover supports, particular attention is given to welding the connections between wall panels and beams and cover plates.

Assembled structures must deviate from the plan by no more than the following values (in mm):

a) Displacement relative to the planned axes of	
column foundations	10
Columns in bottom section	5
Wall panels in bottom section	5
Beams	5
b) Deviation of column axes from vertical position..	8
Wall panel surfaces	9
c) Deviation from planned level of foundation	
casing bottom	10
Top of columns	+10, -15
Top of wall panel bearing surfaces	+10, -18
Top of beams	+10, -18
d) Ellipticity along top edge of wall panels	-52

§7. Filling Joints

Filling the joints (especially between the wall panels and in the bottom) is the most important operation in constructing tanks. The joints are the most vulnerable point in relation to possible product leakage.

In order to obtain a high quality joint it is necessary to observe the following order of operations:

a) surfaces to be joined are treated with sand blasting equipment, which makes it possible to remove any grease film, dust, or carbonized layer of cement stone, and to increase the strength of the bond between old and new concrete significantly;

b) the grade of concrete for filling joints must be no lower than the grade of concrete of the surfaces to be joined; the settling of a standard cone of the concrete mix is 3.5 - 5 mm;

c) the wooden form is set from the inside of the joint to the top, the outer form is made of panels 1 m high and set according to the order of pouring; in order to eliminate cracks between the joint form and the wall panel concrete, it is useful to glue porous material (rubber 20 mm thick) on the surface of the form; when the form is pressed against the surface of the panels the middle part of the rubber is squeezed into the joint cavity (Fig. 11.4, a); a joint form may also be made without the use of rubber (Fig. 11.4, b);

a) Displacement relative to the planned axes of column foundations	10
Columns in bottom section	5
Wall panels in bottom section	5
Beams	5
b) Deviation of column axes from vertical position..	8
Wall panel surfaces	9
c) Deviation from planned level of foundation casing bottom	10
Top of columns	+10, -15
Top of wall panel bearing surfaces	+10, -18
Top of beams	+10, -18
d) Ellipticity along top edge of wall panels	-52

§7. Filling Joints

Filling the joints (especially between the wall panels and in the bottom) is the most important operation in constructing tanks. The joints are the most vulnerable point in relation to possible product leakage.

In order to obtain a high quality joint it is necessary to observe the following order of operations:

a) surfaces to be joined are treated with sand blasting equipment, which makes it possible to remove any grease film, dust, or carbonized layer of cement stone, and to increase the strength of the bond between old and new concrete significantly;

b) the grade of concrete for filling joints must be no lower than the grade of concrete of the surfaces to be joined; the settling of a standard cone of the concrete mix is 3.5 - 5 mm;

c) the wooden form is set from the inside of the joint to the top, the outer form is made of panels 1 m high and set according to the order of pouring; in order to eliminate cracks between the joint form and the wall panel concrete, it is useful to glue porous material (rubber 20 mm thick) on the surface of the form; when the form is pressed against the surface of the panels the middle part of the rubber is squeezed into the joint cavity (Fig. 11.4, a); a joint form may also be made without the use of rubber (Fig. 11.4, b);

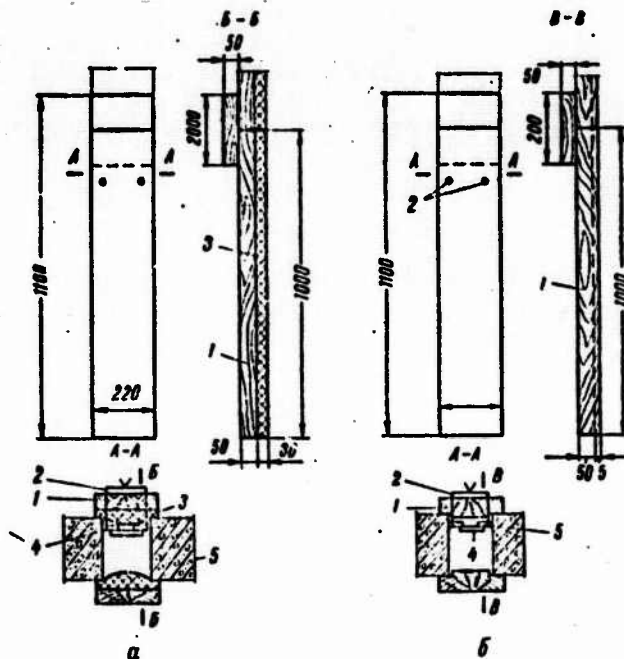

Fig. 11.4. Form for filling joints between wall panels. a - with sponge rubber packing; b - with labyrinth packing; 1 - form panels; 2 - wire twist ties; 3 - sponge rubber packing; 4 - projecting ends of reinforcement; 5 - wall panels.

§8. Winding Stressed Ring Reinforcements Onto the Tank Wall

A number of reinforcement winding machines have been created for winding ring reinforcement onto reinforced concrete tanks. The specifications of the principle ones are given in Table 11.5.

The winding machine is installed on the tank cover. Its upper carriage moves along the edge of the cover, for which a strip 200 - 300 mm wide on the cover is leveled out. There must be no irregularities greater than 10 mm high on the outer surface of the tank wall (they are levelled out with mortar).

The winding machine is assembled by a crane with a long boom. The upper carriage contains the operator's seat (or cabin), the control panel, coils of wire, a boom for lifting the coils, and

apparatus for raising the bottom carriage. A pivot, which is supplied with electricity for powering the machine, is set up in the center of the cover. The upper carriage is connected with the central pivot by a light steel girder. The lower carriage is suspended from the upper on cables. It contains the moving mechanism, along the sprockets of which passes an endless roller bearing chain, mounted on the wall of the cylindrical tank. The sprockets in rotating (driven by an electric motor) impart motion to the lower carriage. The carriage has rubber wheels which roll along the wall. The carriage contains equipment for tensioning the chain. The wire tensioning mechanism consists of a conical disc, cut into three parts. The disc is fitted with a sprocket which rotates with the roller bearing chain when the carriage is in motion. The diameter of the sprocket is larger than the diameter of the disc, thanks to which the length of wire passing through the disc during one rotation is less than the length of chain passing through the sprocket during one revolution. Because of this difference

Table 11.5

Properties	Reinforcement winding machines			
	AHM-5	AHM-5M	AHM-7	AHM-10
Tank diameter, m	9-42	9-42	16-70	9-80
Greatest tank height, m	8.5	12	12	15
Greatest diameter of wire wound, mm	5	5	5	5; strands 6 x 2.5 or 7 x 2.5
Maximum wire tension, kg	2500	2500	2500	3000 (for 5000 strands)
Winding speed, m/min	60	60	60, 90, 120	80; 120
Capacity: 1 kg wire for 1 H	up to 500	560	up to 1100	up to 1500 (for up to 1870 strands)
1 m wire for 1 H	3600	3600	up to 7200	up to 7200
Winding spacing, mm	5-300	5-300	5-300	5-300
Rated power, kw	7	7	19.5	25.6
Weight of machine, kg	4000	—	11,600	16,100
Minimum width of free space around tank, m	1.5	1.5	2.5	2.5

in speed, the wire is tensioned. By changing the diameter of the expandable conical disc, the linear speed of the wire coming from it and, correspondingly, the tension, are changed.

Hydraulic instruments which indicate the amount of wire tension when the machine is in motion are installed on ANM-5M, ANM-7 and ANM-10 winding machines.

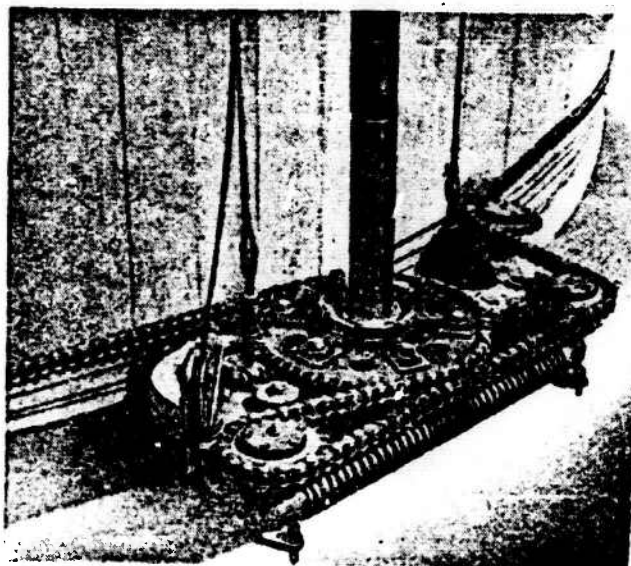

Reproduced from
best available copy.

Fig. 11. 5. General view of a winding machine.

The upper and lower carriages are connected with a metal ladder which serves as a carrier for transmitting motion from the lower carriage to the upper. At the same time, the ladder is a guide for vertical movement of the lower carriage.

When there is a break in the wire during winding, the coils are connected with special clamps every 500 - 1000 m of winding. At the moment of fastening the coils with clamps, a special instrument measures the tension in the wire and records it in a winding journal. In each zone (belt) the total tension must not differ by more than 10% from the planned tension. Upon finishing a reel of wire, the end of the reel is spliced with a new reel with the aid of a special machine using a splice 150 mm long, and the splice is wrapped with steel wire 0.8 mm in diameter.

Changing reels takes up a great deal of time. At the present time a system of feeding wire without lifting the reel to the upper carriage is being developed, which significantly shortens winding time.

A general view of a winding machine is shown in Fig. 11.5.

§9. Protecting Stressed Ring Reinforcement From Corrosion

It is necessary to protect wound stressed ring reinforcement from the moisture contained in the dirt covering of the tank in order to avoid corrosion. For this, a layer of cement gunite-plaster 25 - 30 mm thick (2 layers 12 - 15 mm each) is applied to the reinforcement. The joints between panels are subjected to guniting from the inside of the tank wall, which increases their impermeability. The concrete surface of the wall is sand blasted before applying the gunite-plaster.

Guniting is performed in two ways: 1) dry with the aid of a cement gun, and 2) wet - with a pneumatic mortar pump.

The dry method goes as follows. A dry mixture of sand and cement (dried sand) is loaded into the cement gun. Compressed air (from a compressor) forces the mixture from the gun along a hose into a nozzle. Water is supplied under pressure in the nozzle. Although this method is widely used, it has substantial disadvantages: the insufficient wetting of the mixture with water, in some cases the mixture divides into sand and cement; the great pulverization and rebounding of the solution during the process of the operation (30 - 50%); the removal of the cement with the wind. The dry cement-sand mix has a composition of 1: 3 or 1: 2.

The wet method is based on the use of a standard mortar pump (with a capacity of 3 - 6 m³/h) and a mixing chamber into which compressed air from a compressor is supplied. A solution (cement-sand-water) with a water/cement ratio of 0.4 - 0.5 m with standard cone settling of 5 cm is fed into the mixing chamber.

The wet method does not require dry sand. The rebound is reduced significantly, there is no splattering and no wind danger. The wet method fills the spaces between coils better, especially in the case of multi-layer winding of reinforcement.

The whole complex of mechanisms for guniting is put together into one moveable device.

The "Gazstroy Mashina" special design office has built a test model of a mechanized TST-1 device for applying a gunite mixture (by the dry method). The solution is applied in a 12 - 15 mm layer. If it is necessary to apply two layers, the interval of time between them must be 4 - 5 hours (the setting time of the solution).

Guniting of the outer surface of the wall is performed with the tank filled with water, and the inner surface -- with the tank empty and not covered with dirt.

In the case of a multi-row winding of reinforcements (stressing the bottom and cover) the thickness of the gunite layer between the rows of reinforcement must be no less than 5 mm, and the thickness of the outer layer -- 25 - 30 mm.

During the first three days, the gunite-plaster is covered with water every 3 hours during the day and once at night, and then for 4 days it is covered with water 3 times a day.

A gunited cover is checked by tapping with a small hammer. A defective section produces a hollow sound, it is cut out and replaced with a new one.

§10. Testing and Accepting Tanks for Use

After all construction-assembly operations are completed, the tank is subjected to testing -- filled with water (before covering with dirt). The gas tightness of the cover is tested by means of pumping air into the gas space (with a filled tank). During the testing

process, the settling of the tank is determined, for which marks are put on the cover at the following points before it is filled with water: in the center, over the columns, and along the edge above the wall every 12 - 15 m. These level marks are checked during the entire testing period. Settling differences must not exceed the following values:

a) between the center and the points on the cover over the wall -- 0.0003 of the tank diameter or 0.0005 of the width of a rectangular tank; but in all cases not more than 25 mm;

b) between points on the cover above adjacent columns -- 0.0008 of the distance between columns, but not more than 5 mm.

After filling the tank with water to the designed level, the amount of water leakage in the course of 3 days is determined (with a Maksimov deflectometer). Using a tape measure for measuring leakage is possible only for tanks with a capacity of less than 5000 m³. Before testing, it is necessary to check whether all hatches and catches are closed and sealed, etc.

The allowable standard for losses is: for 3 days -- 3 liters/1 m² of wettable surface; for 6 days -- 1.5 liters; for 9 days -- 0.1 liters; for 15 days -- 0.7 liters.

During testing there must be no inflow of water on the wall surface and discharge of water from under the bottom. Darkening (wetting) of individual sections of wall is allowed. If there are defects, the water is removed from the tank, the defects eliminated and testing is repeated.

Only tanks having a cover with a waterscreen are tested for gas tightness. Water is poured on the cover, no later than a day before testing. All equipment on the cover (hatches, valves, etc.) are closed tightly. Air is pumped in to a pressure of 20 mm of water above the pressure to which the breathing valves are regulated (to 200 mm of water). Pressure is measured with a water manometer, attached to a pipe union on one of the hatches.

The results of testing are considered to be satisfactory if during the course of 1 hour the pressure in the gas space drops by no more than 50% of the initial level. All flanges and weld joints of the equipment and hatches are washed in the process of testing for gas tightness. A cartogram of defects is compiled as a result of testing.

§11. Tank Construction in Wintertime

The development of a technique of performing operations in wintertime has very great significance, since reinforced concrete tanks usually are constructed in large tank farms and it is very difficult to finish all tanks in a warm period.

The excavation, assembly of prefabricated reinforcement concrete elements, and winding the outer reinforcement onto the tank wall in the wintertime are performed using the same methods as in summer. Pouring the bottom, filling the joints and gunniting differ significantly in the winter period.

Before constructing the dirt base under the concrete footing of the tank bottom, it is necessary to have laboratory data on soil composition. The soil moisture must be such that the danger of frost heaving is eliminated, and therefore it is not possible to preheat the ground with hot steam. Also, it is necessary to be convinced that upon thawing the ground will not have deformations which might cause intolerable stresses in the bottom.

The footing is made in the following two ways: 1) with the use of concrete with the addition of chlorine salts (cold concrete, hardening in frost); 2) by means of electric heating, with which method the concrete does not have chlorine salts and is laid on an unheated base. When using cold concrete the water/cement ratio must be no more than 0.65, and at the points where service pipelines pass into the footing, sections around them 300 mm in width must be concreted without the addition of chlorine salts (in order to avoid corrosion). Research performed by candidate in engineering

V. Ya. Gendin revealed the following optimum temperature conditions for the electric heating of concrete with the addition of soluble glass:

Rate of raising temperature up to 15°C for 1 h
Temperature of isothermal heating, °C to 75°
Heating time, hours 8
Rate of cooling concrete not more than 12°C
per hour

With the above-mentioned conditions observed, the concrete acquires a hardness of 67% of R_{28} after hardening. Pouring concrete with electric heating is possible with an air temperature of not lower than -20°C.

During pouring (before heating) the concrete must have a temperature of not lower than +5°C. In the case of electric heating of the bottom, wood panels measuring 1 x 0.8 m are laid on it. 40 x 4 mm steel electrodes are attached to the lower surface of the panel. Adjacent electrodes are connected to different phases of a step-down transformer circuit.

Electric current passing through the concrete heats it. The upper layers of concrete are heated more rapidly than the lower. Thus, with a steady heating process, the upper layers are heated to 75°C, and the lower to 55 - 60°C. The heating time with a temperature of the lower layers of 60°C is 10 hours, and with a temperature of 50°C is 14 hours. After switching off the voltage, the concrete cools for 12 - 15 hours. The electrode panels are removed when the temperature difference between the upper and lower layers of concrete is no more than 20°C. In the case of electric heating of joints between wall panels, the electrodes are attached to the panels of the wooden form (Fig. 11.6). The electrodes on the outer form are connected to one, and the electrodes on the inner form to the other phase of an electrical circuit. Current passes through the joint and heats the concrete.

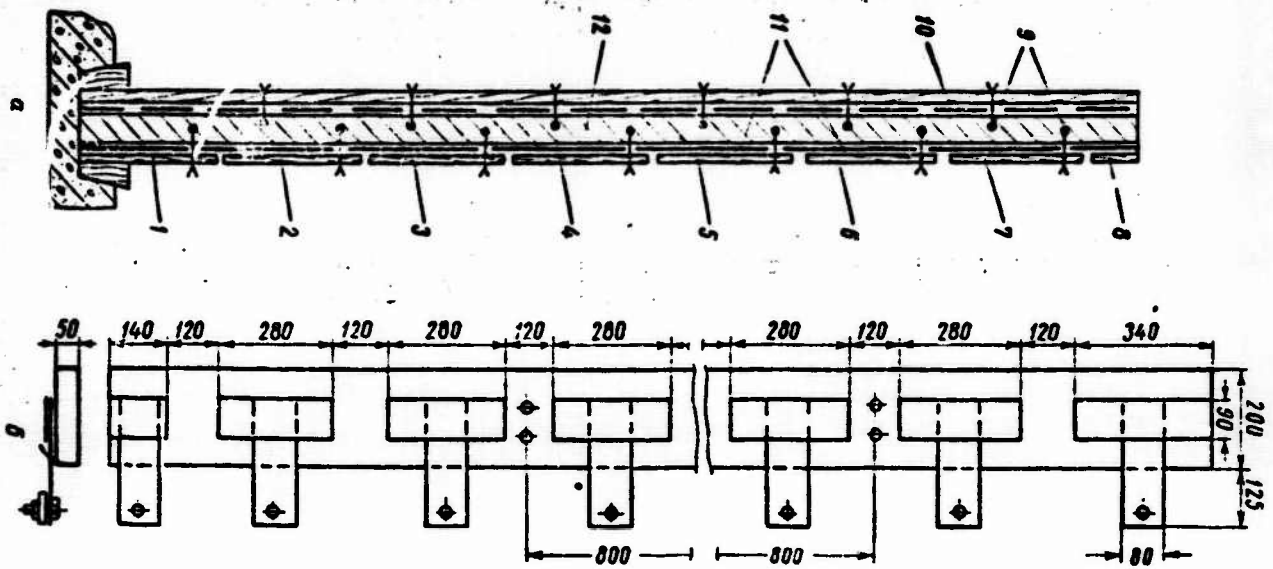

Fig. 11.6. Form for filling and electric heating of joints between wall panels. a - method of setting up wood panels; b - location of electrodes (on inner form); 1 - 8 - wood panels; 9 - twist ties; 10 - inner form; 11 - electrodes; 12 - concrete of joint.

The joints between cover plates are heated in a similar way. The entire process of electrical heating is monitored with industrial thermometers. Monitoring is more effective with the use of remote automatic methods.

Guniting operations are performed with an external temperature of down to -20°C . The equipment for guniting is placed in a temporary shelter and water heated to 40°C (with the dry method) is pumped along heated hoses (pipes). With the wet method, the solution is supplied at a temperature of 15°C .

The surface undergoing guniting is heated with the aid of moveable temporary shelters (warm air up to 10°C). The air temperature in the shelter is 20°C . The hardening time with such a temperature in the shelter is 48 hours.

§12. Safety Precautions During Tank Construction

The safety rules for constructing reinforced concrete tanks differ from the rules in the case of constructing ordinary commercial buildings because of the special requirements for performing the operations of winding on stressed ring reinforcements, performing guniting work, testing tanks and performing electric heating of the concrete.

Only these special requirements are discussed here.

1) When winding on ring reinforcements it is possible that the wire will break, which presents great danger for people standing near the tank. Before beginning winding, it is necessary to place a temporary fence with warning sounds around the tank. If the fence is constructed at a distance of 6 m from the tank wall, its height is lower than the level of the cover by no more than 1.6 m. If the fencing is set at a greater distance from the tank, its height is taken according to the data in Fig. 11.7. 2.5 is the shortest possible fence height. The fencing is made of a metal net with a mesh of 200 - 250 mm and a rod diameter of 3 - 5 mm set on wooden poles.

All personnel engaged in winding reinforcement must pass special instruction and the operator and his helpers must take exams and pass them satisfactorily.

All auxilliary operations during winding (supplying reels, attaching coils, etc.) are performed only with the machine stopped.

2) Workers engaged in electric heating must take the appropriate instruction, and pass exams satisfactorily.

A circuit voltage of over 220 V is forbidden for electric heating.

Electrodes are allowed to be attached only after pouring operations are finished and the workers are behind the fence.

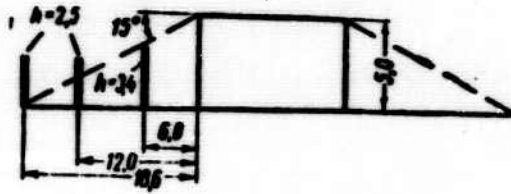

Fig. 11.7. Diagram for determining the required height of fencing in relation to its distance from the tank.

Electrodes attached to wall panels (in the case of heating the bottom or joints) or rod electrodes may be switched on immediately after setting up the panels, but in this case the voltage must be no more than 50 V.

3) In testing a tank with water, when the water level reaches one-half of the intended level, all work on the tank (with the exception of measuring the level) ceases, and the workers are removed to a distance of not less than 12 m. Movement of any equipment is allowed at a distance of 12 - 15 m from the tank.

The person in charge of construction is kept away during testing.

Chapter Twelve

BASIC EQUIPMENT OF TANKS AND GAS HOLDERS

Sl. Equipment of Underground Steel Tanks

Tanks for Heavy Oil Products

A diagram of equipment arrangement is shown in Fig. 12.1. The basic data on equipment (for a 15,000 m³ capacity tank) are given in Table 12.1.

Table 12.1

Name	Material	Number	Type
Man-hole hatch	Steel	2	LL-500
Skylight	Steel	2	LS-500
Siphon cock	Iron,		
	Steel	1	SK-80
Cutoff, $p_y = 10 \text{ kgs/cm}^2$	Iron	1	$D_y = 150 \text{ mm}$
Pipe for cleaning	Steel	1	$D_y = 150 \text{ mm}$
Foam overflow chamber	Steel	3	-
Level measuring instrument	-	1	UDU
Measuring hatch	Iron,		
	Steel,		
	Aluminum	1	-
Measuring hatch assembly connection	Steel	1	-
Receiving-distributing connection 300 mm diameter	Steel	2	PRD-300
Lifting pipe hinge	Steel,		
	Iron	1	SHD-300
Lifting pipe	Steel	1	$D_y = 300 \text{ mm}$
Assembly pipe	Steel	1	$D_y = 250 \text{ mm}$
Ventilation pipe	Steel	1	VP-250
Bypass arrangement	Steel	2	-
Winch	Steel	1	LR-1000
Roller unit	Steel	1	-

The skylight is set in the tank cover over the gate valve mounted on the receiving-distributing pipe. It serves for ventilating and illuminating the tank during repair work. An emergency cable to the gate valve, to be used in case the gate valve fails to operate, is

attached to the inside of the hatch. The hatch diameter is 500 mm.

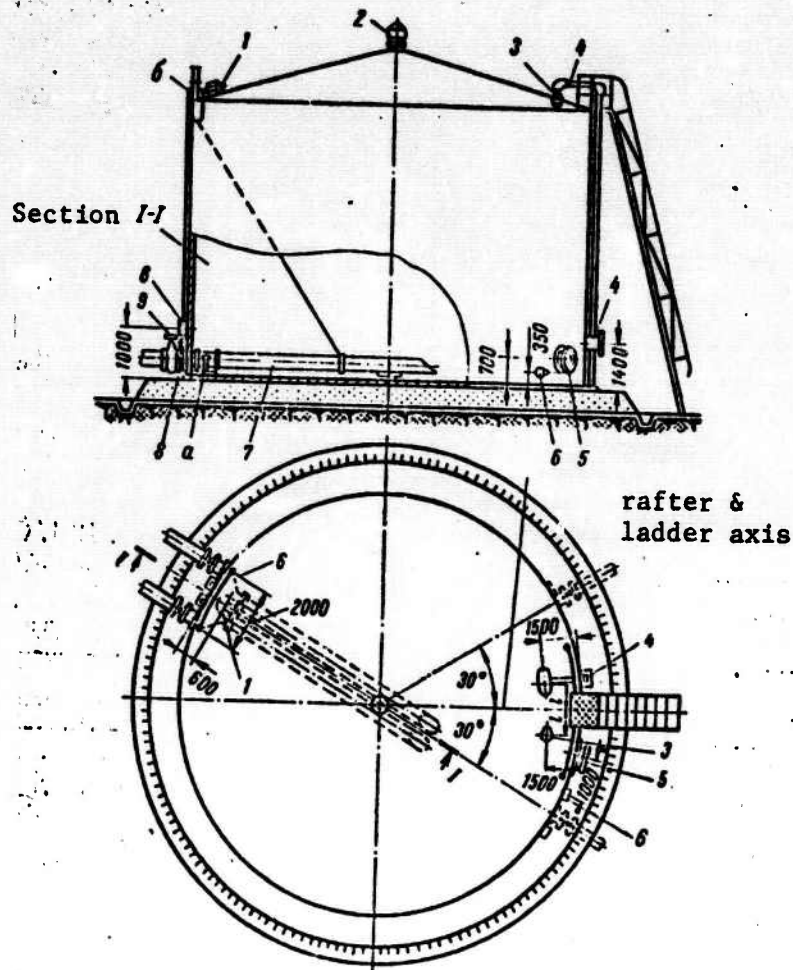

Fig. 12.1. Diagram of equipment arrangement on tanks for heavy oil products and oils. 1 - skylight; 2 - ventilation pipe; 3 - measuring hatch; 4 - level measuring instrument; 5 - man-hole hatch; 6 - siphon cock; 7 - lifting pipe with joint A, rolling unit B and manual winch C; 8 - receiving-distributing pipe; 9 - bypass arrangement.

The man-hole hatch is installed on the first (bottom) level of the tank. It serves for ventilation and entrance to the tank during repair or cleaning. The hatch diameter is 500 mm. The man-hole hatch is attached on bolts to a rim which is welded into the body of the tank. The hatch is designed to withstand the greatest hydrostatic pressure. A gasket is installed between the rim flanges and the hatch.

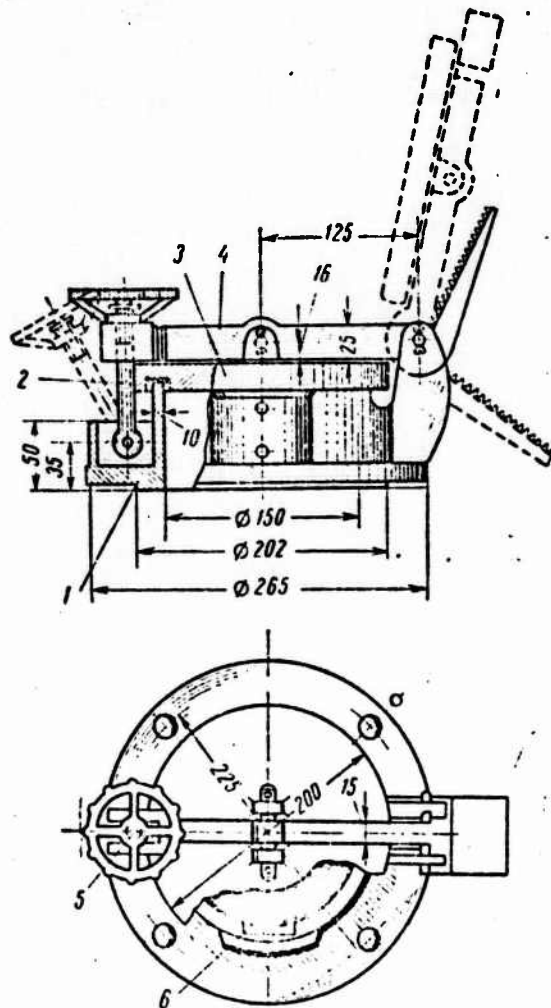

Fig. 12.2. Measuring hatch. 1 - housing; 2 - gasket; 3 - cover; 4 - lever with pedal; 5 - hinged bolt with hand wheel; 6 - guide block.

The measuring hatch (Fig. 12.2) is installed on the tank cover and is intended for measuring the product level and taking samples. The hatch is mounted on a pipe with a flange, which is installed on the tank cover. The diameter of the hatch is 150 - 200 mm. The cover is attached to the measuring hatch with a hinged bolt with a hand wheel. A graduation line with numbers (tank height stencil) which indicate the total height of the tank, is attached to the inside of the throat of the hatch. A guide block (of soft metal) along which a tape measure with a thumb bob is lowered, is set inside the hatch for accuracy of measurement.

The siphon cock (Fig. 12.3) is installed on the bottom level of the tank and is designed for draining off water under the oil. The cock consists of a pipe, passed through a stuffing box into the tank, where the pipe has a bent elbow. The stuffing box cock is mounted on the outer end of the pipe. The cock can be set in three positions with the aid of the handle: a) for draining off water; b) off position; c) for washing the valve. For tanks of up to 5000 m³ capacity, the valve has a diameter of 50 mm, for tanks of larger capacity - 80 mm.

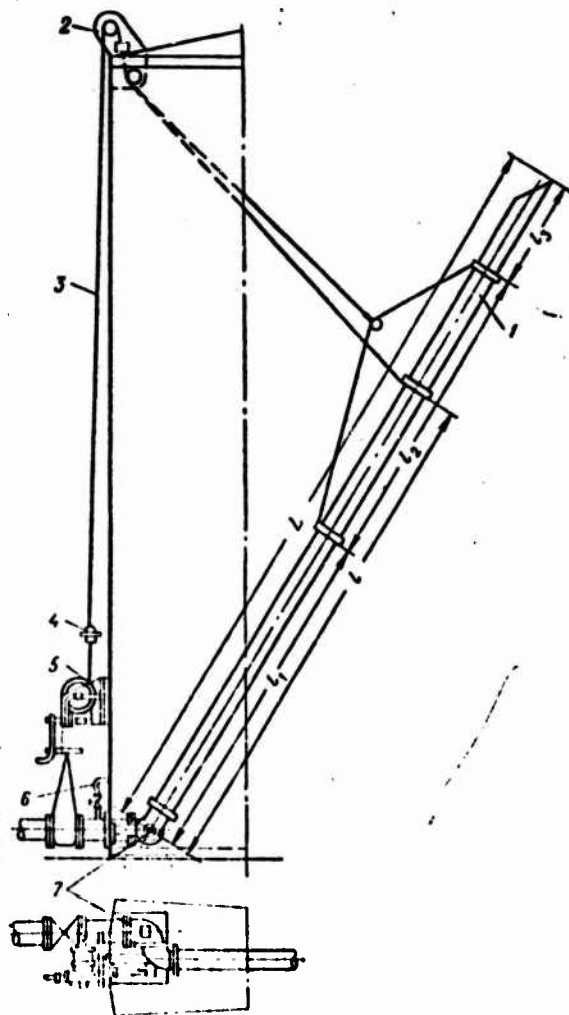

Fig. 12.4. Lifting pipe installed inside tank.
 1 - lifting pipe; 2 - roller unit; 3 - steel cable;
 4 - indicator of position of lifting pipe; 5 - winch;
 6 - bypass arrangement; 7 - lifting pipe hinge.

One or two receiving-distributing pipes are mounted on the first level of tanks, depending on the operations involved in pumping in and draining off the product stored. The pipes are welded into the body of the tank, and are reinforced with a collar. A shutoff valve and then inter-tank connecting pipes are attached to the pipe from the outside. The lifting pipe hinge or the gate valve is attached to the inner end. The dimensions of the pipe are chosen according to the plan. All operations of receiving and delivering the product are performed through the receiving-distributing pipe.

The lifting pipe (Fig. 12.4) is connected with the receiving-distributing pipe with the aid of a hinge. It is used for taking oil and oil products from the upper layers where the oil is cleaner and has less viscosity. The dimensions of the pipe are taken according to All-Union State Standard 4849-47. The pipe hinge is cast iron and consists of two branches (two elbows) connected together in the vertical plane. The winch for moving the pipe vertically is attached to the tank wall and its lifting capacity is 500 - 100 kgs.

The heaters are intended for lowering the viscosity of heavy oil products. They may be in sections consisting of pipes $d \leq 50$ mm, connected with a collector. Individual sections are connected into a branch pipe, and the branches are arranged symmetrically on the bottom in relation to the rising pipe. Steam enters and condensate leaves each branch independently. The branches are mounted on special supports allowing their height to be changed and thus providing the necessary slope for the removal of condensate.

The heaters may also be of the coil type, the coils being mounted on special racks.

Tank Equipment for Light Oil Products

A diagram of the equipment arrangement is shown in Fig. 12.5. Data on the equipment (for a 5000 m³ capacity tank) are given in Table 12.2. The construction of the skylight, man-hole hatch, measuring hatch, receiving-distributing pipes and the siphon cock are analogous to those given above.

Table 12.2

Name	Material	Number	Type
Man-hole hatch	Steel	1	LL-500
Skylight	Steel	1	LS-500
Siphon cock	Steel	1	SK-80
Measuring hatch	Iron, Aluminum	1	-
Foam overflow chamber	Steel	3	-
Level measuring instrument	-	1	UDU
Receiving-distributing part	-	2	PRP-500
Safety valve	Iron, Aluminum, Steel	3	KPS-350-200
Breathing valve	"	3	KD-350-190
Fire safety device	"	6	OPL-350
Assembly pipe for switching in gas leveling system	Steel	7	$D_y = 350 \text{ mm}$
Gate valve control	Steel	2	KH-500
Gate valve	Steel	2	KH-500
Bypass arrangement	Steel	2	-

The breathing valve (Fig. 12.6) lets gas out of the tank when the product is pumped into it, and lets air into the tank when the product is pumped out.

The valve automatically connects the gas space with the atmosphere. Whether the tank remains intact depends on the breathing valve being in good working order; if the valve does not open when the internal pressure in the gas space of the tank reaches a certain value, the tank cover may be tore apart, and in the case of a vacuum - the cover may collapse. The valve seats and discs are located inside the casing of the mechanical valve. The valve casing is made of aluminum or gray cast iron. There are two chambers in the valve: an excess pressure chamber and a vacuum chamber.

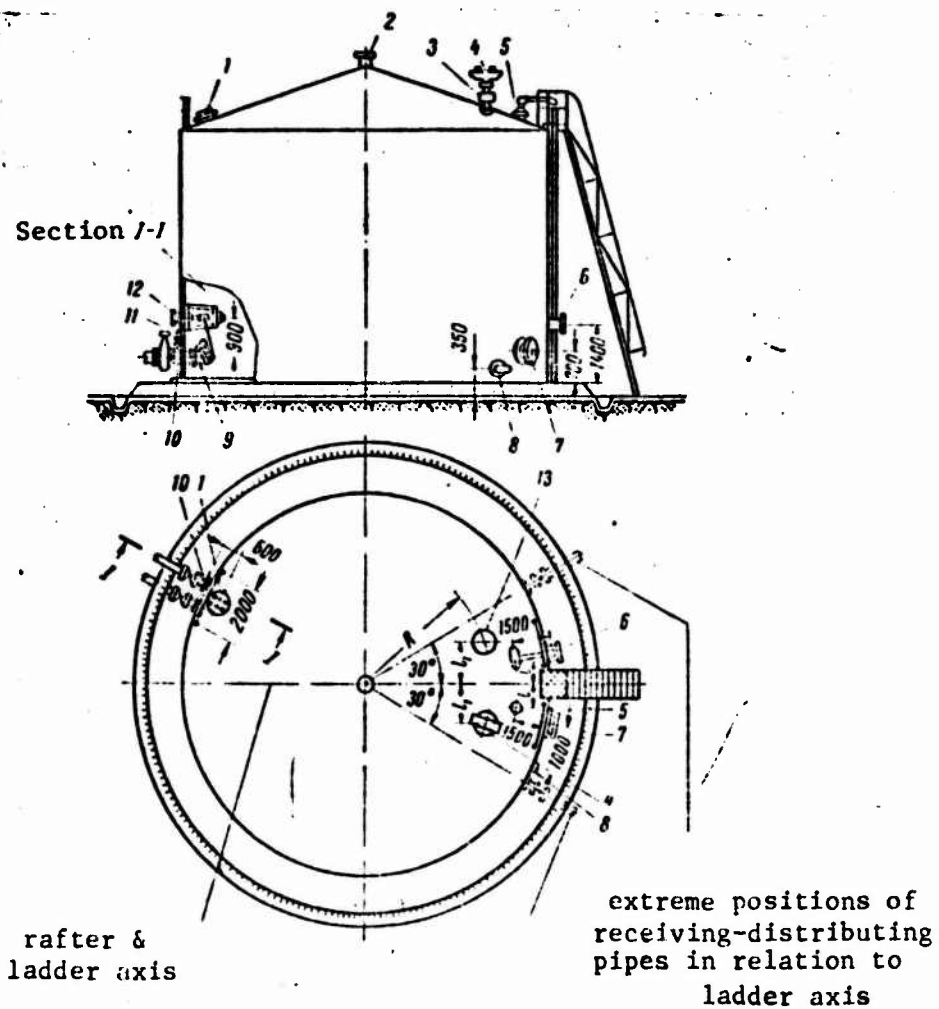

Fig. 12.5. Diagram of equipment arrangement on tanks designed for storing light oil products, crude oil and diesel fuel. 1 - skylight; 2 - ventilation pipe; 3 - fire safety device; 4 - breathing valve; 5 - measuring hatch; 6 - level measuring instrument; 7 - man-hole hatch; 8 - siphon cock; 9 - gate valve; 10 - receiving-distributing pipe; 12 - gate valve control (side); 13 - safety valve.

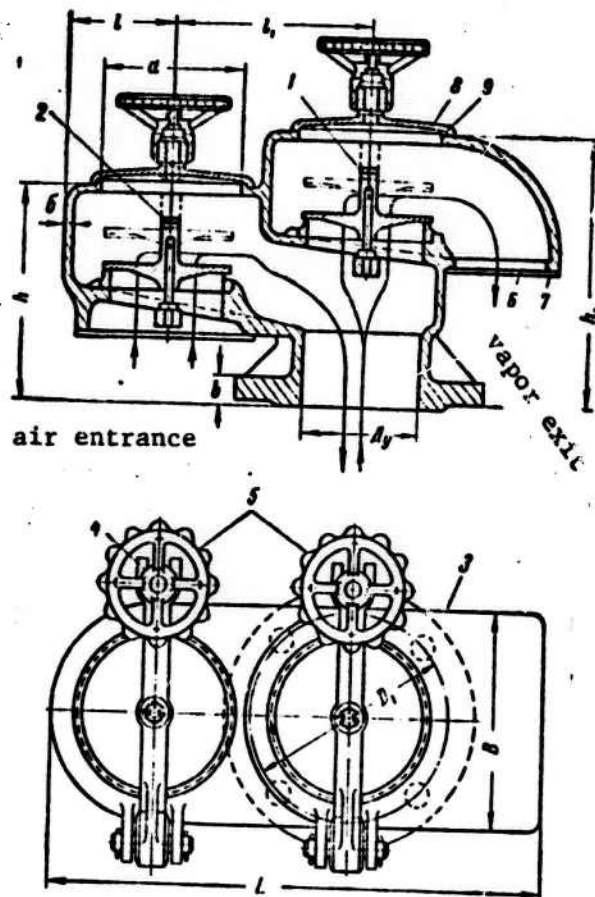

Fig. 12.6. Breathing valve. 1 - pressure valve; 2 - vacuum valve; 3 - valve casing; 4 - hinged bolt; 5 - hand wheels; 6 - screen; 7 - screen ring; 8 - lid; 9 - gasket.

The valves and seats are made of AL-2 aluminum alloy (All-Union State Standard 2695-62), the guides - of stainless steel. Commercially manufactured valves actuate upon a pressure of 20 mm of water in the gas space of the tank. The limit of applicability of commercial breathing valves may be raised to a pressure of 460 mm of water and of a vacuum of 100 mm of water by means of increasing the weight of the valves with regulating weights. The greatest transmissive capacity of the DK-250 valve (nominal inside diameter 250 mm) at high pressure is 685 m³/h. The entrance and exit openings of the valve are protected with a copper screen in order to prevent the valve from clogging and to prevent the entrance of sparks. The breathing valve is installed on the fire protection device.

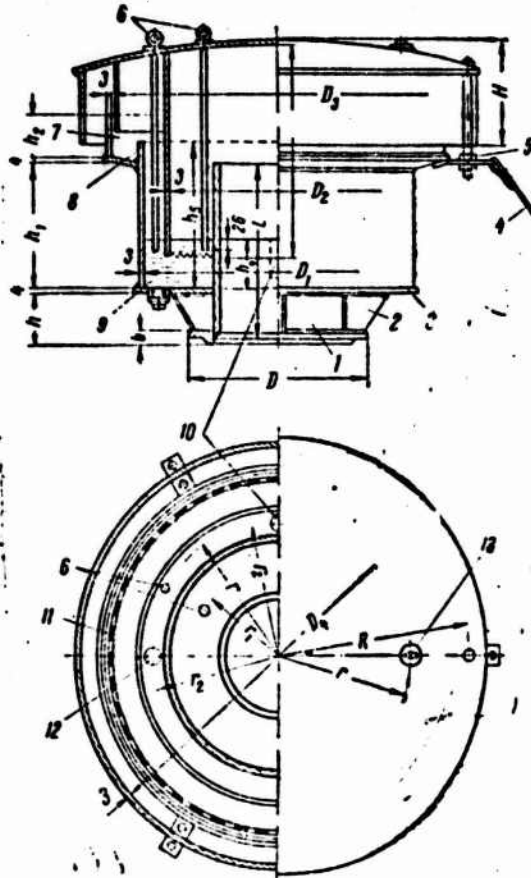

Fig. 12.7. Safety valve. 1 - valve connection; 2 - stiffening rib along circumference; 3 - bottom of oil cup; 4 - expansion bolt for attaching valve; 5 - pin for regulating hydraulic seal; 6 - dipsticks for measuring oil level; 7 - cup for catching oil; 8 - openings for returning oil flowing from screen; 9 - oil cup; 10 - overflow pipe; 11 - screen for catching oil removed with air; 12 - oil drain plug; 13 - plug for pouring oil in.

The following rules are observed in installing the valve:

- 1) the valve is mounted strictly vertically (in order to eliminate the danger of guide rods sticking);
- 2) the weight of the valve must correspond to the design specifications;
- 3) the discs must be carefully fitted to the seats.

A hydraulic safety valve (Fig. 12.7) is installed on the top of the tank in the case where no breathing valve is used. Valves

according to All-Union State Standard 4630-49 are designed for a pressure of 60 mm of water in a vacuum of 40 mm of water. A diagram of the operation of the valve is shown in Fig. 12.8. The safety valve is installed in a complex with the fire prevention device (Fig. 12.9) and is filled with oil having a freezing temperature of down to -55°C .

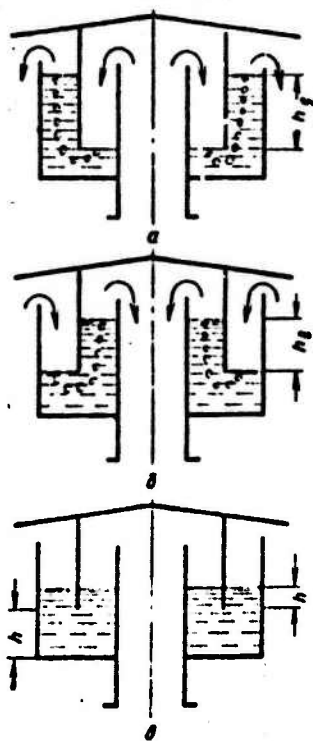

Fig. 12.8. Diagram of the operation of the hydraulic valve. a - excess pressure in tank; b - vacuum in tank (h_v); c - pressure in tank equal to surrounding air pressure.

The fire prevention device (Fig. 12.10). Its operation is based on the fact that sparks and flames cannot penetrate through small openings. Fire prevention devices are installed under breathing and safety valves.

The gate valve with its control and bypass arrangement (Fig. 12.11) is mounted on the receiving-distributing pipe and serves as additional protection from product leakage in the case of a pipeline or shutoff valve not being in proper working order. The flange of the gate valve .

is connected by bolts with a gasket to the receiving-distributing pipe. The greatest diameter of the gate valve is 450 mm. The valve cover must be well-fitted to the housing and must not twist during raising and lowering.

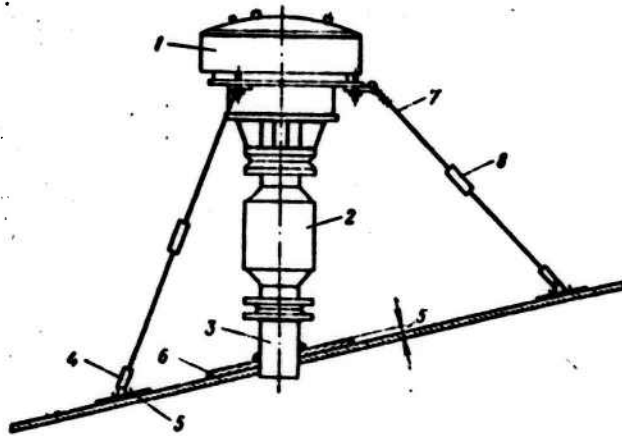

Fig. 12.9. Diagram of valve arrangement. 1 - safety valve; 2 - fire prevention device; 3 - assembly pipe; 4 - hinged hook; 5 - cover plate; 6 - reinforcing collar; 7 - expansion bolt for attaching valve; 8 - tightening sleeve.

When the product is being drained out, the gate valve cover is raised; a bypass arrangement, which equalizes the pressure on both sides of the valve, is installed in order to remove the hydrostatic pressure load on the cover.

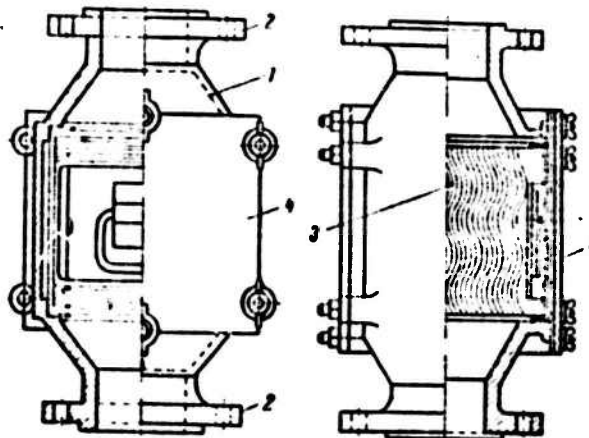

Fig. 12.10. Fire prevention device. 1 - iron casing; 2 - connecting flanges; 3 - holder; 4 - covers.

The level measuring instrument (Fig. 12.12) is intended for determining the amount of oil stored in the tank by means of measuring the level of the top of the oil. The instrument consists of a float, a measuring tape, moving together with the product level, corner boxes and pipes. When the float rises, the measuring tape is wound onto a pulley in the inspection box of the instrument. A cable, which at this time unwinds under the action of a counterweight, is wound onto another pulley mounted on the same shaft.

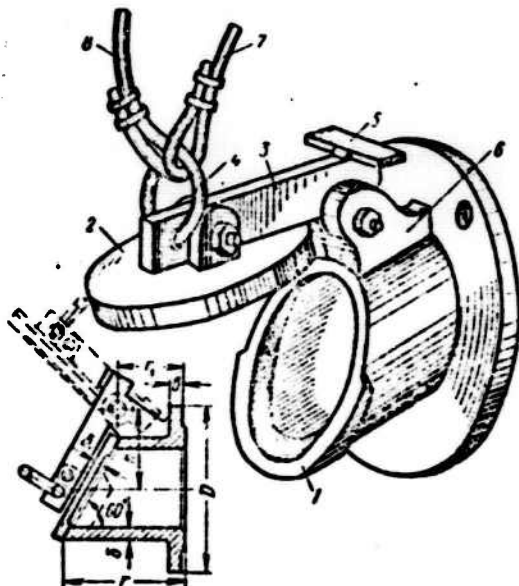

Fig. 12.11. Gate valve. 1 - housing; 2 - cover; 3 - lever; 4 - loop; 5 - stop plate; 6 - hinge lug; 7 - cable for controlling gate valve; 8 - cable to skylight.

A special chamber, allowing the product level to be measured and samples to be taken without disturbing the hermeticity of the tank, is used in high pressure tanks (Dnepropetrovsk Construction Engineering Institute droplet tanks). The chamber consists of a head with a lifting mechanism, a folding valve through which the measuring tape passes, shutoff valves and a pipe.

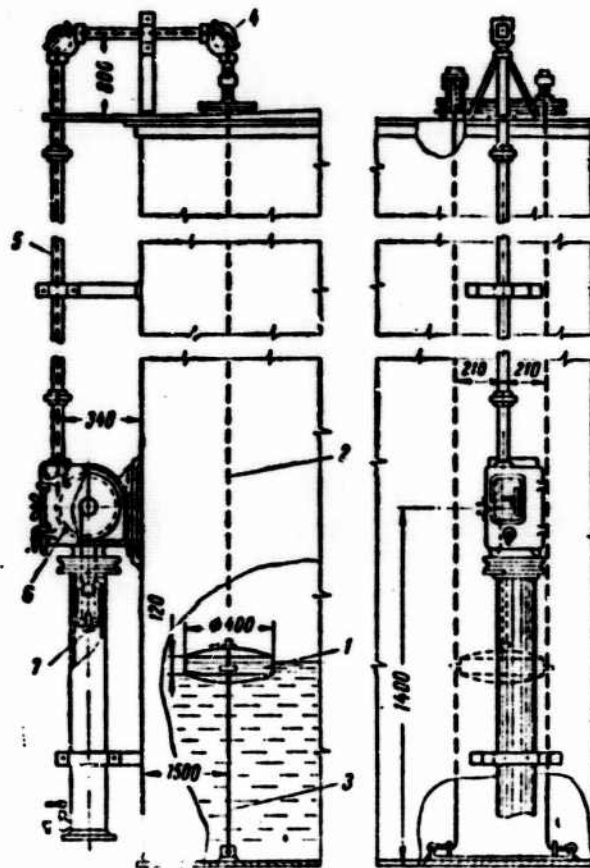

Fig. 12.12. Level measuring instrument. 1 - float; 2 - measuring tape; 3 - guide rope; 4 - corner boxes; 5 - pipe; 6 - pulley in inspection box; 7 - counterweight.

A semi-automatic PSR-4 sampler (Fig. 12.13) which makes it possible to take average samples of oil and oil products, is used for taking samples from ground level tanks directly from the ground. The sampler consists of a column of pipes, assembled with the aid of valve units and removed outwards through the hatch. The top part of the column is fastened to the hatch. The valve unit is a tee which contains a valve closing the opening connecting the sampling pipe with the inside of the tank. The valve unit is connected with an air pipe. During sampling a pressure of 2 kg/cm^2 is created in the air line (with the aid of an automobile pump), under the action of which pressure the valves are closed and the sampling pipe is isolated from the oil. When the valve is open the sample is poured from the sampler into a container.

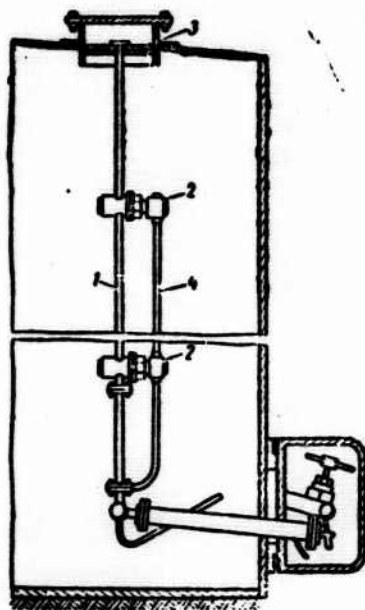

Fig. 12.13. Diagram of semi-automatic PSR-4 sampler.
 1 - sampling pipe; 2 - valve unit; 3 - hatch; 4 - air pipe.

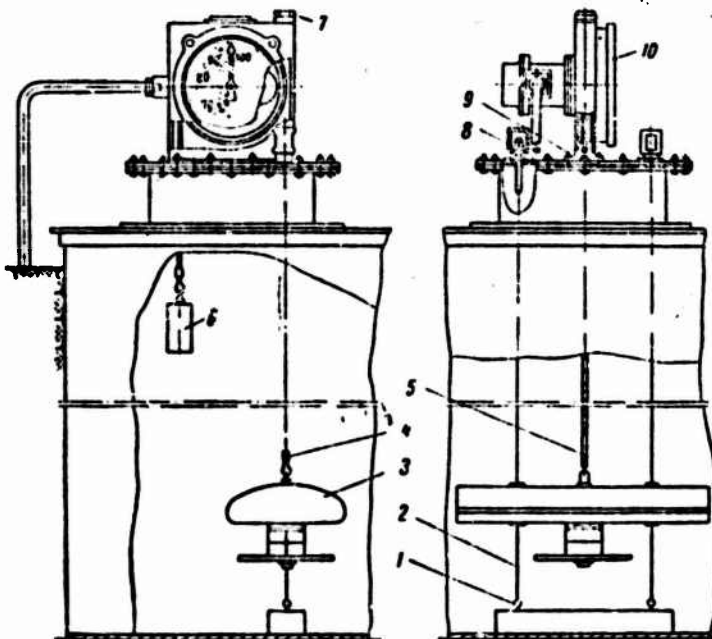

Fig. 12.14. UDU-3 remote transmission level indicator (for buried tanks). 1 - ballast weight; 2 - guide cable; 3 - float; 4 - snap hook; 5 - perforated tape; 6 - counterweight; 7 - plug; 8 - tightening device; 9 - gasket; 10 - level indicator with remote attachment.

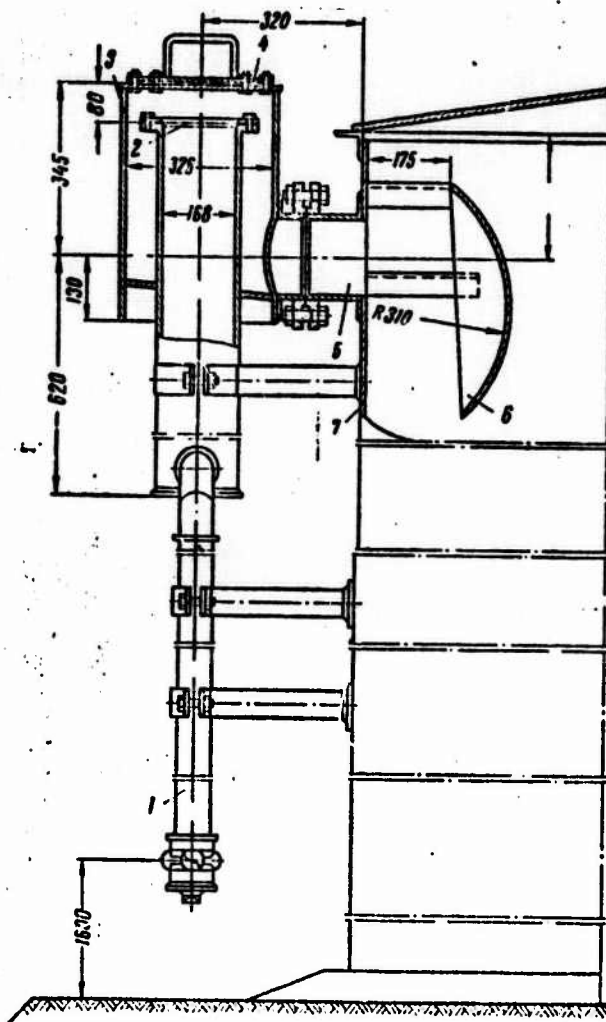

Fig. 12.15. Foam chamber. 1 - foam pipe; 2 - membrane; 3 - chamber housing; 4 - housing lid (for changing membrane); 5 - foam drain; 6 - guide baffle; 7 - top level of tank.

After taking a sample, the pressure in the air line is released and the sampler is readied for the next sample.

A UDU level indicator (Fig. 12.14) is used for the remote transmission of the oil level in the tank. The operation of the level indicator is based on the action of a float which is suspended on a perforated tape and moves along a guide wire. When the float moves, the tape passes through a hydraulic seal and turns a measuring wheel. The rotation of the wheel is transmitted to a counter, which indicates the position of the product level. The measuring tape always is tense,

thanks to a special device (a spring motor) in the indicating instrument. UDU-3's and UDU-5's are provided with attachments (sensors) of the potentiometric or code pulse type for the remote transmission of readings. Different models of UDU's are manufactured for ground level and buried tanks, for tanks with floating covers and for Dnepropetrovsk Construction Engineering Institute tanks with a pressure of up to 3000 mm of water.

Foam drain chambers (Fig. 12.15) are mounted on the top level of tanks for receiving foam and introducing it into the tank. In the case of fire, the foam insulates the oil from atmospheric air (from access to oxygen). In the case of fire, the membrane breaks under the pressure of the foam, and the foam enters the tank. The number of foam chambers is determined by calculation and is indicated in the plan.

§2. Equipment of Buried Reinforced Concrete Tanks

Some types of the equipment used in buried reinforced concrete tanks differ from the corresponding equipment for ground level tanks.

Equipment of Cylindrical Reinforced Concrete Oil Tanks

The tank equipment includes, in addition to skylights, man-holes and measuring hatches, receiving-distributing and cleaning devices, breathing-safety apparatus and monitoring and automatic devices.

The receiving-distributing arrangement serves for pumping the oil into and out of the tank. In standard designs, the receiving-distributing arrangements are calculated for a maximum transmissive capacity of 5000 m³/h (PRU-700, $D_y = 700$ mm). In view of the fact that the walls of cylindrical reinforced concrete tanks are bound with ring reinforcement, which cannot be cut, the receiving-distributing pipes enter the tank through the bottom. Sometimes tanks are equipped with two independent pipes - a receiving and a distributing pipe, and then the first enters through the cover, and the second through the bottom.

A receiving-distributing unit (Fig. 12.16), mounted on the tank bottom, consists of a receiving-distributing pipe (intake), a bottom stop valve and an electrical lifting mechanism.

The receiving-distributing pipes are located somewhat above the bottom so that bottom sediments and bottom water do not enter the pipe when oil is being pumped out of the tank. The plate-type stop (bottom) valve consists of an arrangement preventing the formation of a vortex at the entrance to the suction line, and a raising mechanism with a category VZG type EPB anti-explosion electric motor. The dimensions and number of receiving-distributing units depend on the capacity of the tank and the intensity of receiving-distributing operations (Table 12.3).

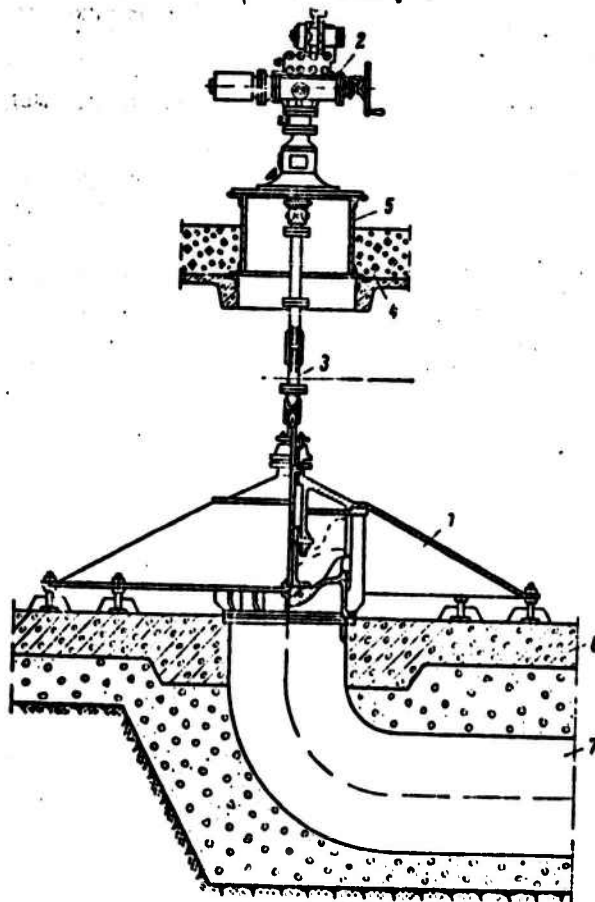

Fig. 12.16. Receiving-distributing arrangement. 1 - bottom stop valve; 2 - electric motor; 3 - hose to bottom valve; 4 - tank cover; 5 - hatch in tank cover; 6 - tank bottom; 7 - receiving-distributing pipe.

The valve construction provides for tight closing of the receiving-distributing pipe and is designed for operation with an outside air temperature of from -40 to +50°C and a temperature of the working medium from -40. to +80°C.

Table 12.3

Tank Capacity, m ³	Pumping Rate m ³ /h	Stop valve	
		Diameter, mm	Number
1000	300	250	1
	100	150	1
5000	1300	500	1
	700	350	1
10,000	2600	500	2
	1700	400	2
20,000	4600	700	2
30,000	2600	600	2
40,000			

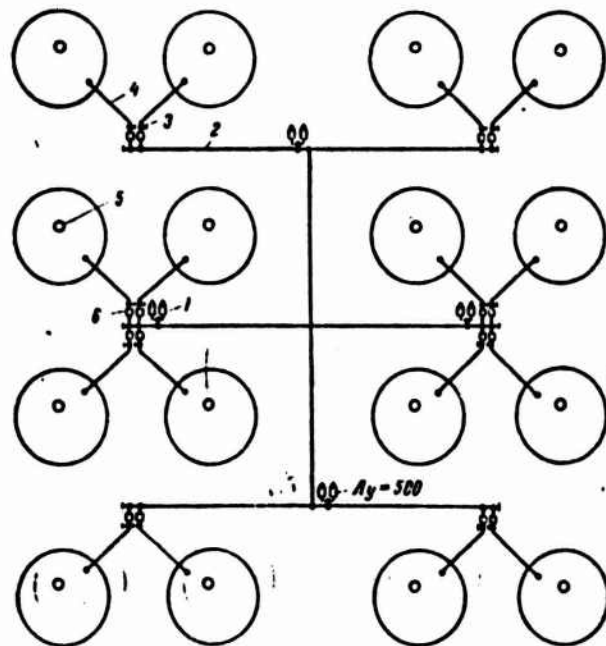

Fig. 12.17. Diagram of centralized (group) installation of breathing apparatus in a 320,000 m³ oil tank farm.
 1 - breathing valve; 2 - asbestos-cement pipes; 3 - shutoff valve (butterfly valve); 4 - metal pipe; 5 - safety membrane valve; 6 - fire prevention device.

The pipeline connecting the tank with an external collector is laid in a conduit and a lens compensator is installed, which reduces the force transmitted to the tank from temperature effects and vertical settling of the tank.

The breathing apparatus in buried reinforced concrete tanks is installed according to two schemes: individual and centralized. In the case of individual installation, breathing apparatus is located on each tank, and in the case of centralized - outside the tanks, and it serves a group of tanks. In the latter case, each tank is equipped

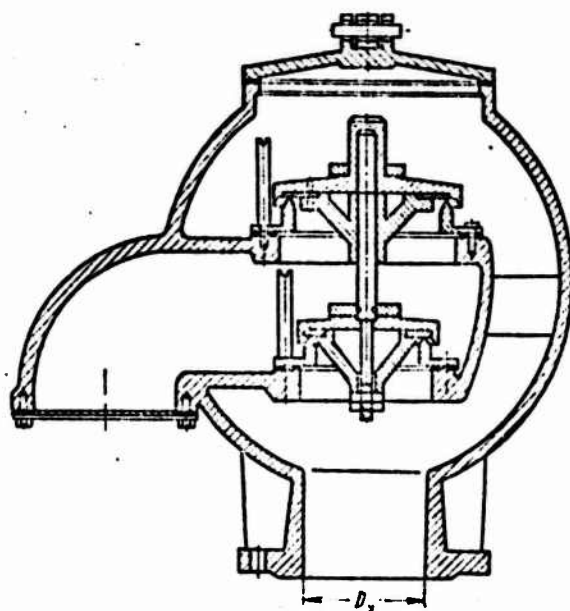

Fig. 12.18. KD-1 breathing valve.

only with a fire prevention device with a breathing pipe connected to the common gas leveling system. In the case of centralized installation, the pressure in the gas space is kept at 200 mm of water. A reserve (membrane) valve is installed on the tank roof in case the gas levelling system breaks down.

At the present time large capacity (up to 40,000 m³) reinforced concrete tanks are being built and with individual installation of breathing valves on each of them it is necessary to equip each of them with several instrument complexes, for example, in a tank farm .

consisting of six tanks (10,000 - 20,000 m each). 352 breathing devices are installed, which greatly increases the cost of the tank farm and reduces fire safety. New types of breathing apparatus (Fig. 12.18) with a transmissive capacity up to 4500 m³/h with a pressure of 200 mm of water in a vacuum of 100 mm of water, and also safety valves (Fig. 12.19) with a transmissive capacity of 3000 m³/h with a pressure of 250 mm of water in a vacuum of 150 mm of water, have been developed for centralized installation (Fig. 12.17). A breathing valve diameter of up to 500 mm is used.

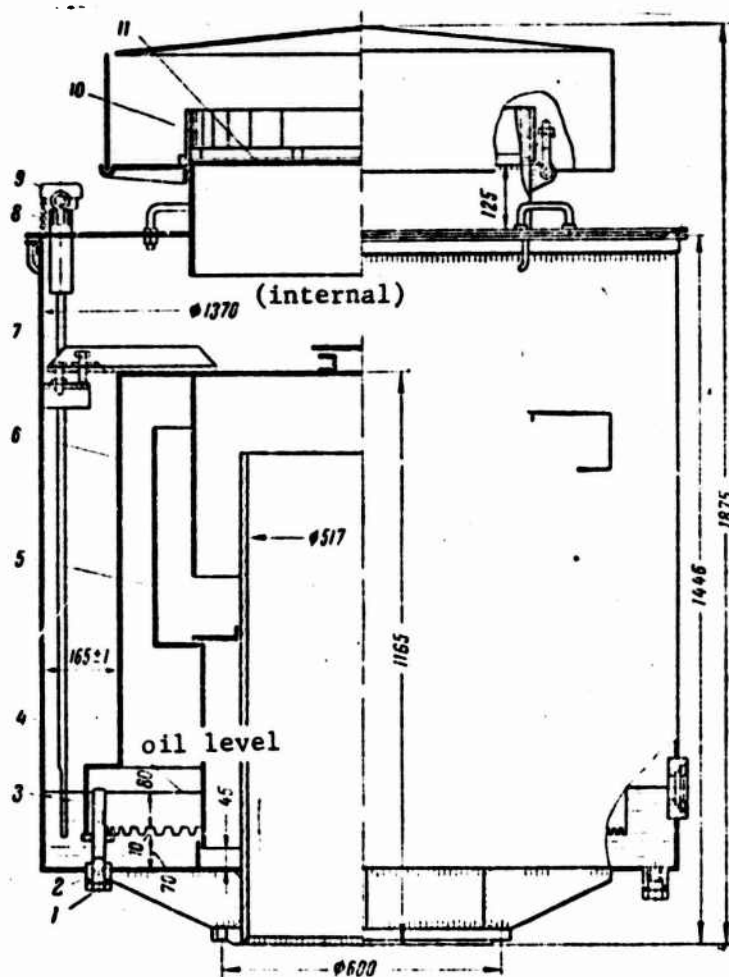

Fig. 12.19. Welded safety valve combined with fire prevention device. 1 - half cm plug; 2 - gasket; 3 - drain pipe; 4 - housing; 5 - cover piece; 6 - cover; 7 - feeler gauge; 8 - chain; 9 - funnel cover; 10 - fire prevention device; 11 - gasket.

§3. Lightning Protection and Protection Against Static Electricity

Oil storage tanks of over 30,000 m³ capacity, equipped with breathing apparatus and located in a tank farm, belong to the first category with respect to lightning protection. According to standard documents, above ground steel tanks (belonging to category I) are protected from direct lightning strikes with individual lightning rods or lightning conductors located on the structure itself, but insulated from it. Above ground and underground current conducting elements of lightning conductors are located at a certain distance from the hearts of the object protected and from all metal elements (pipelines, cables), connected with the object to be protected.

Lightning conductors are rods, cables and nets. Single or double rod lightning conductors, which act together, are used in tank farms. The number of pipes and the length of the connecting strips for circuit grounding of substations is determined according to the specific conditions in relation to the climatic region and the specific conductivity of the ground.

Reinforced concrete tanks are protected from lightning and static electricity according to specifications developed by the G. M. Krzhizhanovskiy Institute. Tank farms and isolated underground reinforced concrete tanks are protected from direct lightning strikes with the aid of a grid, for which it is possible, in part, to use the reinforcement of the cover plates. A telescopic lightning receiver 3.5 m high, connected with a protective grid, is installed near tanks equipped with breathing apparatus. Four grounding leads, each lead being connected to a separate grounding point, are laid out from the grid circuit along the perimeter of the tank. The pulse spreading resistance of each grounding point is taken as no more than 10 ohms.

§4. Equipment of Gas Holders

Wet Gas Holders

The equipment of wet gas holders depends on their purpose and the

arrangement of the installation. If a gas holder operates as a buffer, it has one gas line, through which gas is fed into the holder, when its output exceeds requirements, and goes from the gas holder into the system when demand exceeds production. Gas holders may operate also on a gas line or as mixers of different gases. In such cases, the gas holder may have two or more gas lines. The diameter of the gas lines is taken according to engineering calculations. All basic equipment of a gas holder is located in the gas intake chamber (Fig. 12.20), which is a brick structure, directly adjacent to the gas holder tank. The gasline from the chamber in the form of a stack pipe enters the gas holder downwards through the bottom. The upper end of the stack pipe is 55 mm above the top edge of the tank. When gas is introduced, the hydraulic seal is removed, the purpose of which is to separate the gas holder from the gas lines of the installation during repair and when gas condensate is removed (by means of pouring water into the seal).

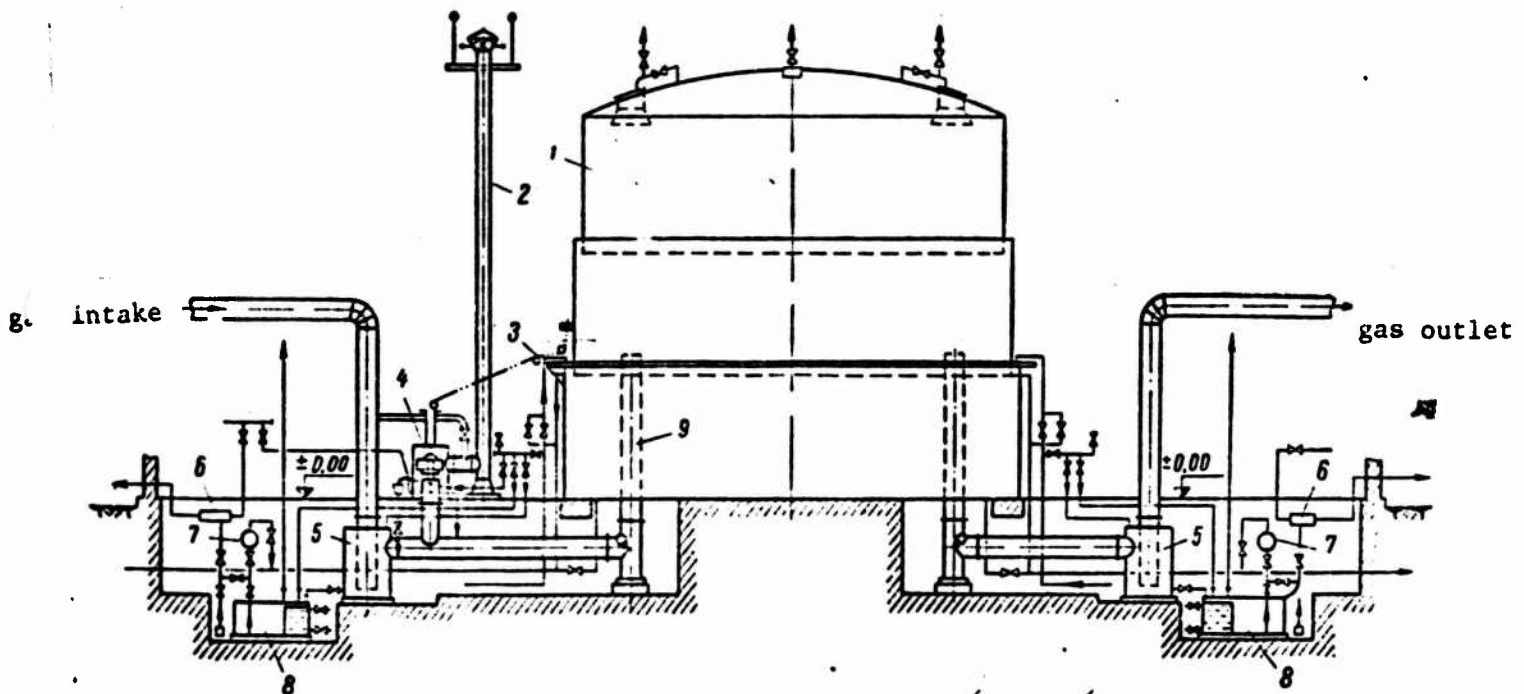

Fig. 12.20. Equipment of a wet gas holder, operating on a gas line. 1 - gas holder; 2 - gas collecting pipe; 3 - receiving valve arrangement; 4 - valve box; 5 - hydraulic seal; 6 - elevators; 7 - hand pump; 8 - drain tank; 9 - gas stack pipe.

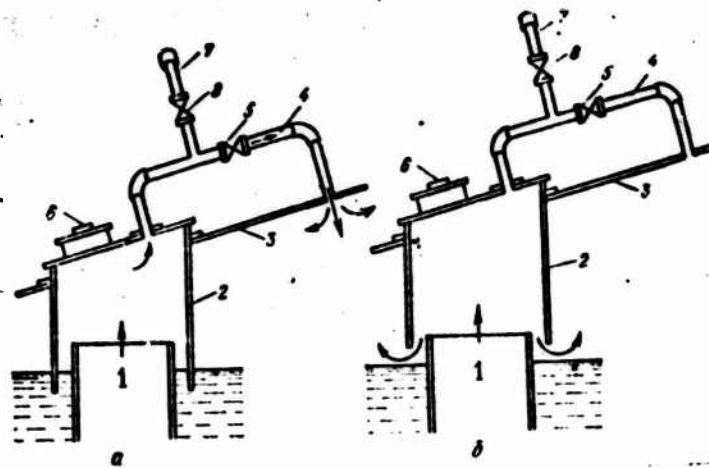

Fig. 12.21. Bypass arrangement. a - gas from gas line enters empty gas holder through bypass pipe, valve 5 open; b - cap removed from water, gas enters valve, while 5 closed; 1 - gas line; 2 - cap; 3 - bell roof; 4 - bypass pipe; 5 - bypass pipe valve; 6 - cap hatch; 7 - blowoff pipe; 8 - blowoff pipe valve.

The chamber contains: shutoff valves on pressure and drain water pipes; gas holder heating control; drainage tank for collecting gas condensate and water from hydraulic seal (when gas holder is in operation); a hand piston pump for pumping water from the drainage tank and pit. So that the gas holder does not become filled, the chamber contains a gas collecting pipe, a valve box for automatically removing gas, and a manual shutoff valve for removing gas.

When the gas holder bell is in the lower position (when there is no gas in the gas holder), the upper end of the gas stackpipe is separated from the space under the cover by a cap attached to the cover (Fig. 12.21). Thanks to the cap, the danger of the appearance of a vacuum in the space under the dome when more gas than is permissible is pumped from the tank. The cap is connected with the space under the cover by a pipe which contains a vertical blowoff pipe (for cleaning the gas holder).

Water in the hydraulic seals and tank is heated with the aid of ring-shaped steam pipes and steam jet elevators - they collect cold water from the lower layers, heat it with steam and blow it into the tank (or hydraulic seals) (Fig. 12.22).

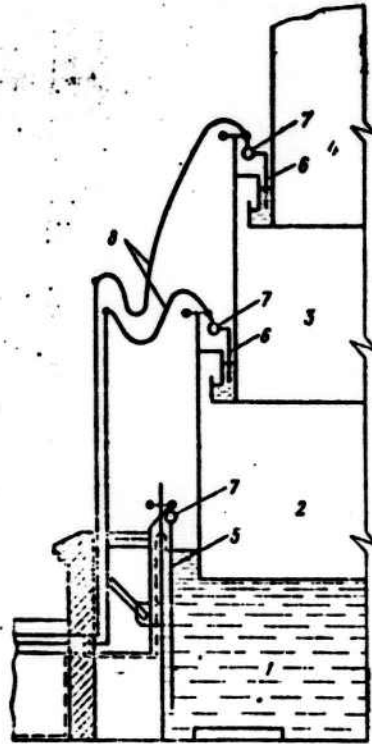

Fig. 12.22. Vertical diagram of heating equipment. 1 - tank; 2 - second lift; 3 - first lift; 4 - bell; 5 - standpipe and steam jet elevator; 6 - steam jet elevator; 7 - ring-shaped steam pipe; 8 - flexible hoses of steam pipe.

Dry Gas Holders (with Flexible Sections)

The equipment of dry gas holders with flexible sections depends, as in the gas of wet gas holders, on their purpose (the gas holder is connected to a deadend pipe or a through pipe or operates as a mixer).

Gas may be introduced into a dry gas holder through the bottom (Fig. 12.23) or through the side wall. In the first case, the gas line entrance chamber is constructed (similar to wet gas holders), and a service area is located in the second chamber. All equipment for controlling the gas holder is located either in the entrance chamber, or in the service area.

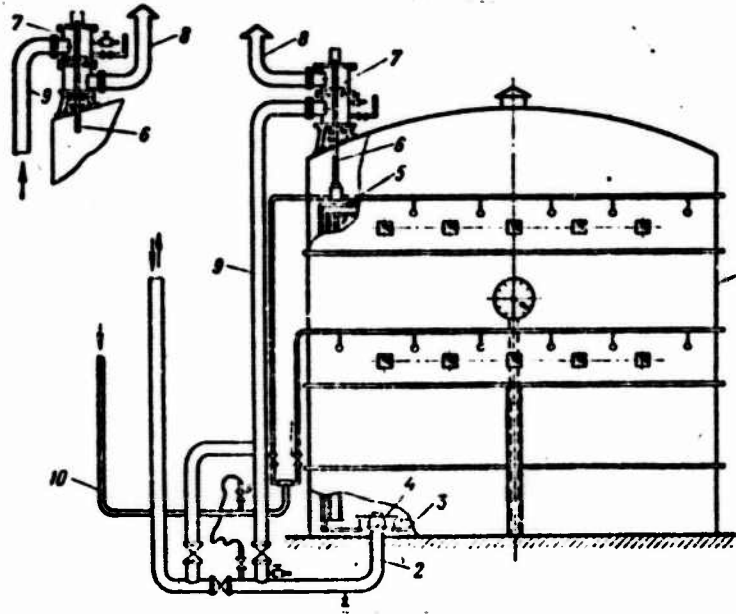

Fig. 12.23. Diagram of dry gas holder equipment.
 1 - housing; 2 - gas line; 3 - bottom of washer (in lower position); 4 - gas line intersecting cover; 5 - top of washer (in upper position); 6 - gas ejector rod; 7 - gas ejector valve box; 8 - gas ejector blowoff pipe; 9 - gas ejector standpipe; 10 - inert gas pipeline.

The equipment of a dry gas holder (safety gas holder) is as follows:

- a) automatic device for releasing gas into the atmosphere (if gas holder is overfilled);
- b) automatic separation of gas holder from gas collecting network;
- c) indicator of gas volume and position of washer, blocking of compressors and separation of gas holder from gas collecting network in the case of extremely low pressure (10% full);
- d) inert gas conducted into space below washer if top zone is overfilled with gas;
- e) fire warning and telephone connection;
- f) lightning protection;
- g) outside illumination and fence.

Gas is forced into the gas holder with compressors.

REFERENCES

- Веревкин С. П., Корчагин В. А. Газгольдеры. В., Стройиздат, 1966. 240 с.
- Герман-Захаров И. М. Хранение сжиженных технических газов. Киев, «Техника», 1966. 222 с.
- Иванцов О. М. Подземное хранение сжиженных углеводородных газов. М., «Недра», 1964. 148 с.
- Колжунов Н. В. Основы расчета упругих оболочек. М., «Высшая школа», 1963. 278 с.
- Клименко А. П. Разделение природных углеводородных газов. Киев, «Техника», 1964. 38 с.
- Корниенко В. С., Поповский Б. В., Личевич Г. В. Изготовление и монтаж стальных резервуаров и газгольдеров. М., Стройиздат, 1964. 320 с.
- Лессинг Е. П., Лижеев А. Ф., Соколов А. Г. Листовые металлические конструкции. М., Стройиздат, 1970. 488 с.
- Пикиреев В. М., Шадурский В. Л. Практические методы расчета оболочек. М., Стройиздат, 1966. 272 с.
- Овечкин А. М. Расчет железобетонных осесимметричных конструкций. М., Стройиздат, 1961. 260 с.
- Пастернак И. Л. и др. Железобетонные конструкции. Специальный курс. М., Стройиздат, 1961. 856 с.
- Стулов Т. Т. и др. Железобетонные резервуары для хранения нефти и нефтепродуктов. Проектирование и сооружение. М., «Недра», 1968. 288 с.
- Сафьярин М. К., Иванцов О. М. Проектирование и сооружение стальных резервуаров. М., Гостехиздат, 1961. 328 с.
- Стрелецкий Н. С. и др. Металлические конструкции. Специальный курс. М., Стройиздат, 1965. 368 с.
- Тимошенко С. ДП. Сопротивление материалов. М., «Наука», 1965. 480 с.
- Тимошенко С. П., Вайповский-Кригер С. Пластинки и оболочки. М., «Наука», 1966. 636 с.
- Франк-Каменецкий Д. А. Диффузия и теплопередача в химической кинетике. М., «Наука», 1967. 491 с.
- Чернык В. И. Проектирование, сооружение и эксплуатация нефтебаз. М., Гостехиздат, 1955. 522 с.