

AD-A008 039

CONTROL CIRCUITS FOR A ROCKET PAYLOAD  
NEUTRALIZATION EXPERIMENT AND OTHER  
TOPICS

Raimundas Sukys, et al

Northeastern University

Prepared for:

Air Force Cambridge Research Laboratories

October 1974

DISTRIBUTED BY:

**NTIS**

National Technical Information Service  
U. S. DEPARTMENT OF COMMERCE

113104

AFCRL-TR-74-0580

ADA008039

CONTROL CIRCUITS FOR A ROCKET PAYLOAD NEUTRALIZATION  
EXPERIMENT AND OTHER TOPICS

Raimundas Sukys  
Steven Goldberg

Northeastern University  
Boston, Massachusetts 02115

October 1974

Scientific Report No. 1

Approved for public release; distribution unlimited.

AIR FORCE CAMBRIDGE RESEARCH LABORATORIES  
AIR FORCE SYSTEMS COMMAND  
UNITED STATES AIR FORCE  
HANSCOM AFB, MASSACHUSETTS 01731

Dep. stored by  
NATIONAL TECHNICAL  
INFORMATION SERVICE  
U.S. Department of Commerce  
Springfield, VA 22151

MAR 31 1975

Unclassified

MIL-STD-847A  
31 January 1973

SECURITY CLASSIFICATION OF THIS PAGE (When Data Entered)

REPORT DOCUMENTATION PAGE		READ INSTRUCTIONS BEFORE COMPLETING FORM
1. REPORT NUMBER AFCRL-TR-74-0580	2. GOVT ACCESSION NO	3. RECIPIENT'S CATALOG NUMBER
4. TITLE (and Subtitle) CONTROL CIRCUITS FOR A ROCKET PAYLOAD NEUTRALIZATION EXPERIMENT AND OTHER TOPICS		5. TYPE OF REPORT & PERIOD COVERED Scientific - Interim
7. AUTHOR(s) Raimundas Sukys Steven Goldberg		6. PERFORMING ORG. REPORT NUMBER Scientific Report No. 1
9. PERFORMING ORGANIZATION NAME AND ADDRESS Northeastern University Electronic Research Laboratory Boston, Massachusetts 02115		8. CONTRACT OR GRANT NUMBER(s) F19628-74-C-0042
11. CONTROLLING OFFICE NAME AND ADDRESS Air Force Cambridge Research Laboratories Hanscom AFB, Massachusetts 01731 Contract Monitor: Alan D. Bailey/LKD		10. PROGRAM ELEMENT, PROJECT, TASK AREA & WORK UNIT NUMBERS 6687-01-01 62101F
14. MONITORING AGENCY NAME & ADDRESS (if different from Controlling Office)		12. REPORT DATE October 1974
		13. NUMBER OF PAGES 27
		15. SECURITY CLASS. (of this report) Unclassified
16. DISTRIBUTION STATEMENT (of this Report) Approved for public release; distribution unlimited.		15. DECLASSIFICATION/DOWNGRADING SCHEDULE
17. DISTRIBUTION STATEMENT (of the abstract entered in Block 20, if different from Report)		
18. SUPPLEMENTARY NOTES TECH, OTHER		
19. KEY WORDS (Continue on reverse side if necessary, and identify by block number) Ionosphere, Electron Ejection, Rocket Neutralization, Circuits.		
20. ABSTRACT (Continue on reverse side if necessary and identify by block number) A Ute Tomahawk rocket was launched on 16 August 1974 from the White Sands Missile Range in New Mexico to test the feasibility of rocket charge neutralization through the ejection of electrons. Description of the circuits used to control and measure the ejection is presented in the first		

DD FORM 1 JAN 73 1473

EDITION OF 1 NOV 55 IS OBSOLETE

Unclassified

SECURITY CLASSIFICATION OF THIS PAGE (When Data Entered)

Figure 6. Report Documentation Page.

PRICES SUBJECT TO CHANGE

MIL-STD-847A  
31 January 1973

Unclassified

SECURITY CLASSIFICATION OF THIS PAGE (When Data Entered)

part of this report. Summary of other work performed during the first twelve months under this contract is given in the second part. This work consisted mostly of modifications and preparation of existing electronic assemblies for mass spectrometers to be flown on rockets.

// Unclassified

SECURITY CLASSIFICATION OF THIS PAGE (When Data Entered)

## TABLE OF CONTENTS

	<u>Page No.</u>
TABLE OF CONTENTS -----	iii
LIST OF ILLUSTRATIONS -----	iv
INTRODUCTION -----	1
CHAPTER I. ELECTRONIC DUMP CONTROL -----	3
A. System Description -----	3
B. Circuits -----	5
C. Encountered Problems -----	8
CHAPTER II. ELECTRONIC SUBASSEMBLIES FOR MASS	
SPECTROMETERS -----	10
PERSONNEL -----	13
RELATED CONTRACTS AND PUBLICATIONS -----	13

LIST OF ILLUSTRATIONS

<u>Figure No.</u>		<u>Page No.</u>
1.	Experiment Block Diagram -----	14
2.	Functional System Diagram -----	15
3.	Meter Circuits -----	16
4.	Sweep Generator -----	17
5.	Control Circuits -----	18
6.	Power Transfer and Monitor Circuits -----	19
7.	Emission Current Control -----	20
8.	RF Oscillator -----	21
9.	Test and Control Circuits -----	22

## INTRODUCTION

During its flight through the ionosphere the skin of a rocket acquires a negative charge. The resulting potential difference between the vehicle and the surrounding plasma may influence the results of some experiments conducted in that region. Therefore, it would be desirable to neutralize the vehicle with respect to the ionosphere while these experiments are in progress. To investigate the feasibility of rocket payload neutralization an experiment has been proposed by Dr. C. Sherman of Air Force Cambridge Research Laboratories in which electrons would be removed from the vehicle and ejected into the surrounding plasma. One such experiment has been previously instrumented and flown. Alan D. Bailey from AFCRL designed the original electronic system and the circuits to implement that experiment. Also a second experiment has been successfully conducted on a Ute Tomahawk rocket A09.214-2 launched on 16 August 1974 from White Sands Missile Range in New Mexico. A modified version of the original electronics have been designed and constructed at Northeastern University for this second experiment. These electronic circuits used to control the "dumping" of electrons into the ionosphere and therefore referred to as the "Electronic Dump Control" are described in the first part of this report.

The second part of the report summarizes other work performed during the first twelve months under this contract. This effort was spent mostly on modifications and preparation of electronic subassemblies for airborne mass spectrometers to meet the specific requirements of several upper atmosphere composition measurement experiments.

The basic mass spectrometer control units were designed and built by Tri-Con Associates Inc. for AFCRL. These instruments contained RF and dc voltage generators for the excitation of the quadrupole mass filters, a programmer for exciter control, a signal processor in a form of an electrometer amplifier or a pulse counter-converter, a filament emission control for an ionizing source (where required) and a multi-output power converter to operate the above mentioned circuits from a single dc source. Adaptation of these units to the specific requirements of the individual experiments included adjustment and modification of the existing circuits, as well as the design and assembly of additional circuitry as dictated by the peculiarities of each experiment.

Five units were modified. Two units were adapted for high altitude measurements (above 100 km) of positively ionized and neutral constituents in an auroral arc. Two other instruments were modified for the positive ion and one instrument for the negative ion measurements in the D region.

## CHAPTER I

### ELECTRONIC DUMP CONTROL

#### A. SYSTEM DESCRIPTION

A simplified block diagram of the instrument is shown in Figure 1. An electron gun consisting of an indirectly heated cathode (K), three accelerating grids ( $G_1$ ,  $G_2$  and  $G_3$ ) and a screen grid formed the main electron ejection system. The cathode was cycled between -49.5 volts and +0.5 volts with respect to the vehicle by the cathode bias source. The bias voltage made linear transitions between the two voltages in approximately half a second and rested at each of the extreme values for two seconds. The accelerating grids were kept at a constant potential. Therefore the accelerating grids moved from zero to +50 volts with respect to the screen grid during each cycle of the cathode bias waveform thereby controlling the flow of the electrons into the plasma.

Three currents were measured. The source current meter measured that portion of the cathode current which had a return path through the screen grid or the plasma. The cathode current returning through the accelerator grids was excluded from this measurement. Currents returning from the screen grid and from the skin of the vehicle were measured by the screen grid and the difference current meters respectively. To minimize interference from currents flowing through stray capacitances a bias voltage was supplied to a guard shield.

To construct the control system with the electronic current meters and to insure the desired current paths through these meters, two batteries isolated

from and in addition to the main 28 volt vehicle battery were required. Dc-dc converters were avoided in the floating parts of the system to minimize noise interference. For the operation of the cathode bias source nominal 63 volts were provided by the battery B2 shown in Figure 2. The battery consisted of 52 nickel cadmium 250 mAH cells. Twenty six such cells supplied nominal 31 volts to the source and the screen grid current meters. The  $\pm 15$  and the  $\pm 30$  volts necessary to drive the guard shield bias circuit as well as the isolation stages of the two above mentioned current meters were derived through dc-dc converters. The difference current meter which referenced the whole system to the vehicle was also powered by the  $\pm 15$  volt supply.

The three different paths the cathode current can take may be traced in Figure 2. That part of the cathode current which returned through the three accelerator grid circuits, including the driver transistors and the chain of zener diodes, (introduced to bias the grids at different potentials, if necessary) remained completely within the B2 system. The current that flowed through the screen grid entered the B3 system through the emitter of the bias sweep output transistor Q and the source current meter (M1). The return path carried it through the screen grid current meter (M2) and the grid back to the cathode. The current that completed its path via the plasma passed again through the source current meter and the B3 system, entered the difference amplifier (M3) and reached the skin of the vehicle through the 15 volt supply. To eliminate any other current paths the outputs of the source and the screen grid meters were isolated from the telemetry circuits by FET operational amplifiers. The cathode bias sweep control signal was transmitted through the optically coupled isolator.

## B. CIRCUITS

A detailed circuit diagram of the dump control electronics is shown in Figures 3-6. The current meters were implemented using operational amplifiers. To accommodate currents up to 50mA the outputs of the operational amplifiers were augmented with discrete transistors. The difference current meter was designed to accommodate approximately four decades of current with a maximum at 50mA. Ordinary signal diodes 1N4148 when used in the feedback loop of an operational amplifier were found to produce a rather good logarithmic compression over that current range. Since considerable deviation from the logarithmic response could be observed at currents over 15mA with a single diode, four diodes were employed to construct the logarithmic amplifier. Occasional small reverse currents were expected to flow through the meter circuits during switching and laboratory testing. Reverse currents up to 500 nA could be accommodated in the logarithmic amplifier. The resistor connected between the +15 volt supply and the input to the log amplifier for stabilization purposes provided that current. A further increase in the reverse current disabled the log amplifier, but the system remained referenced to the vehicle through the diode connected between the input to the log amplifier and the ground. The maximum reverse current that could be tolerated was limited to 50 uA by the resistors in the emitter circuits of the other two meters. Further increase in this current resulted in a loss of ground reference and disrupted the operation of the system.

The cathode bias voltage sweep was generated by a high voltage operational amplifier connected to perform integration. The circuit is shown in Figure 4. Zener diodes shunting the integrating capacitors established the amplitude of the trapezoidal sweep voltage, while a square wave transmitted

through the optically coupled isolator determined the period of the waveform. The output of the integrator was referenced to the vehicle through an emitter of a power transistor and the "virtual ground" formed by the source and the difference current meters. This connection forced the potential between the floating battery B2 and the vehicle to follow the integrator waveform. An avalanche diode was inserted between the negative terminal of the battery and the cathode to shift the positive extreme of the sweep to +0.5 volts above the vehicle potential.

To protect the battery (B2) against a temporary short or other unexpected high current drain, a current limiting circuit was included ( $Q_1$ ). The collector current was limited to 110 mA by the emitter resistor and the diodes in the base circuit. Therefore at currents below 110 mA the transistor remained in saturation and supplied the necessary voltage to the accelerator grid circuit and the collector of the cathode bias transistor. When this current was exceeded, the transistor left the saturation region, became a current source and limited the current from the battery. The sweep generating high voltage operational amplifier was separately protected against excessive output currents which could destroy the unit. The current to the circuit was limited to four milliamperes by a FET transistor operating in a constant current mode.

The fifty volt changes in the potential between the battery B2 system and the vehicle made it necessary to shield the system against currents that might flow through stray capacitances. These currents, although small, could introduce considerable error in the difference current measurements obtained from the log amplifier. The guard shield signal was derived from the cathode bias

signal (Figure 4) through a voltage divider and an isolation amplifier, but was powered from the +28 volt vehicle power supply through a dc-dc converter. After amplification the shield bias voltage swept in phase through an identical trapezoid as the B2 system, therefore a constant voltage difference between the two was maintained at all times.

A battery which powered the heater filaments required slightly more shielding. The heaters, although ideally floating, could become loosely coupled to the B2 system in a way that the two would sweep slightly out of phase producing a path for error currents through the guard shield circuit. Therefore, an inner shield was connected directly to the cathode, while an outer shield was driven by the guard shield signal.

The timing signal to control the cathode bias sweep was derived from a UJT clock and a decade counter with decoded outputs. The circuits are shown in Figure 5. The primary reason for inclusion of the decade counter was the need to synchronize other instruments with the cathode bias signal. A three bit code could be selected through an appropriate closure of the switches to control the status of other instruments. Power transfer, battery charging and monitor circuits are shown in Figure 6.

The complete electronic dump control package measured 16.3 x 13 x 9.7 centimeters of which 16.3 x 13 x 4.3 centimeters were occupied by the two Ni-Cd batteries (B2 and B3). Welded cordwood construction was used to package most of the circuits into modules. The modules were placed on one of the two decks in the box while the other deck was used to mount the two dc-dc converters, power transfer relays, monitor resistors and the power transistors to drive the accelerator grids.

### C. ENCOUNTERED PROBLEMS

Two noteworthy problems, both associated with leakage currents, were encountered during the testing of the system. One of the problems appearing during the early stages of testing was a presence in the log amplifier output of a step of  $\pm .1V$  which corresponded to the positive and negative sweeps of the system. This appeared to be a capacitive effect and was finally traced to the five power transistors used in the grid control circuitry. These transistors (TIP's 52, 42, 142) had large ( $2.5\text{cm}^2$  each) collector plate surfaces which were separated from the grounded system box by mica insulators ( $5.6 \times 10^{-3}$  cm thick). The calculated capacitance for these transistors, which had all their collectors in common, was about 1000 pF. This value agreed with the value required for the effect seen in the log amplifier output. The capacitance was reduced by placing a fiberglass board (.16cm thick) between the box plate and the transistors which were also placed on a heat sink having twice their area. The net effect was a reduction of the leakage current approximately 15 times (to 70pF). An acceptable 15mV step was then seen at the output.

The final electronic dump control circuit tests were performed at AFCRL. When operating as part of a system, with the electronic dump cage containing the cathode and the grids placed in a vacuum chamber, the sweep and the current monitor circuits revealed an existence of two problems which did not occur when the electronic dump control unit was tested separately. The circuits could be driven into a "hang-up" condition when the system was switched from battery charging into the operating state or when large line transients occurred during switching of the 9.6A of current to the electronic dump cage filaments. These transients apparently caused a latch-up condition in either the source

current or the difference current meters thereby destroying the virtual ground reference for the sweep circuits. The cause of this problem was traced to the capacitance associated with the guard shield and the circuits driving the shield. The overall control arrangement of the experiment was such that during the battery charging period, the negative terminal of the sweep circuit battery (B2) was grounded. When the system was transferred to the operating status, B2 floated and the negative terminal of the battery quickly assumed a low potential with respect to the ground. This produced a significant reverse current flow through the capacitance of the guard shield and through the source and the difference current meters which were not designed to accommodate large reverse currents. Similar currents were apparently induced by the ground line transients produced by the filament power switching. The effects of these transients were eliminated by a 240k resistor placed between the guard shield driving circuit and the shield itself. This resistance and a test capacitance of 2800 pF (much less existed in the real system) caused a lag of 0.67 milliseconds between the cathode and the guard shield sweep voltages; an insignificant amount when compared with the 500 millisecond sweep time.

## CHAPTER II

### ELECTRONIC SUBASSEMBLIES FOR MASS SPECTROMETERS

Five mass spectrometer electronic assemblies were modified and prepared for flight. Also a light portable instrument for testing of the electronics in the field has been designed and built. The electronic assemblies that were modified and/or prepared for flight experiments included two switchable ion/neutral units, one negative ion and two positive ion instruments.

The switchable units required the most extensive preparation. Modifications were required in practically every existing circuit board as well as in the pre-wired harnesses. Major changes were made on the relay and the filament power supply boards where the emission regulator and the various switchable bias circuits were located. The part of the emission regulator which included the current to frequency converter and the ionization current monitor circuits, shown in Figure 7 to the right of the dashed line, were packaged into two cordwood modules. Although not very flexible for modifications and changes, the cordwood construction was employed to save space. Few of the circuit components most likely to be changed during the calibration process to accommodate the operational peculiarities of each instrument were placed outside the cordwood packages. This type of construction resulted not only in a saving of the available space, but also provided an easier access to the critical components than the usual flat construction would allow with that number of components. The switchable bias circuits shown to the left of the dashed line in Figure 7 were placed on the relay board using the conventional flat construction with a point to point wiring. The modular cordwood construction was once again used for the high voltage and the vacuum ion pump system monitor circuits.

The negative ion mass spectrometer electronics required mostly adjustments to obtain the spectrum. The main problem encountered with this unit was the inability of the RF oscillator, shown in Figure 8, to sustain oscillations when the compartment housing the transformer was covered to shield the rest of the instrument from RF radiation. This problem was overcome by increasing the base drive of the power transistors to a point where without the shield the oscillator would lock-up into a mode of oscillation which did not respond to the amplitude control signal. The base drive was increased by increasing the value of the capacitor (C) connecting the feedback windings to the bases of the transistors. When the shield was reapplied and the losses increased, the oscillator once again responded to the sweep control signal. This very hard drive of the transistors produced a substantial increase in the distortion of the signal driving the peak detector (Z), but this did not appear to disturb the operation of the spectrometer. Another problem associated with the oscillator was an insufficient amplitude of the RF signal to obtain the mass spectrum up to 200 amu. Addition of turns to the secondary windings did not increase the output amplitude. This could be attributed to the increased losses requiring more power from the transistors to sustain the same amplitude as before. Lowering the values of the resistors supplying the dc bias control to the bases of the power transistors increased the collector currents to the maximum rated value without any significant change in the output signal. Obviously the transistors were pushed to the limit of their capability. Some experimentation was done with a parallel drive circuit where two transistors were used to drive each side of the coil. With this arrangement peak voltages between 800 and 900 volts could be reached but the oscillator would overheat and would stop working. It should be pointed out that this approach was not fully explored because

of time limitations. Since the original oscillator produced sufficient RF peak voltage (700V) to reach 172 amu and it was impossible to obtain more powerful transistors in the allotted time, the instrument was deemed acceptable for the experiment to be performed.

The preparation of the two positive ion mass spectrometers for the A L A D D I N series of experiments were routine with only minor modifications and/or additions required.

A portable instrument to test the mass spectrometers in the field was built. The diagram is shown in Figure 9. All points from the mass spectrometer interface connector were brought out to the patch-board and were accessible for monitoring purposes. The wires carrying data and the main monitoring signals which were common to most of the instruments were permanently connected to six microammeters. Ten additional signals could be selected and displayed two at the time on the other two microammeters. This could be done through the appropriate connections in the patch-board and the two pole five position rotary switch. LED indicators were used to display the status of the control relays in the mass spectrometer as well as the status of the test instrument itself. Power for the LED indicators and for the control of the relays in the mass spectrometer was provided by the dc-dc converter which in turn received its power from the external source used to power the mass spectrometer. For convenience the test instrument has been built into a briefcase.

### PERSONNEL

A list of the engineers, technicians and student assistants who contributed to the work reported is given below:

J. Spencer Rochefort, Professor of Electrical Engineering, Principal Investigator.

Raimundas Sukys, Senior Research Associate, Engineer.

Steven Goldberg, Research Assistant, Engineer.

Harry Tweed, Technician, Electrical Engineering.

Charles Sebastian, Project Assistant.

Thomas Palasek, Project Assistant.

Dominic Mancini, Project Assistant.

### RELATED CONTRACTS AND PUBLICATIONS

F19628-74-C-0042

1 September 1973 through present.

No other publications have been issued under this contract.

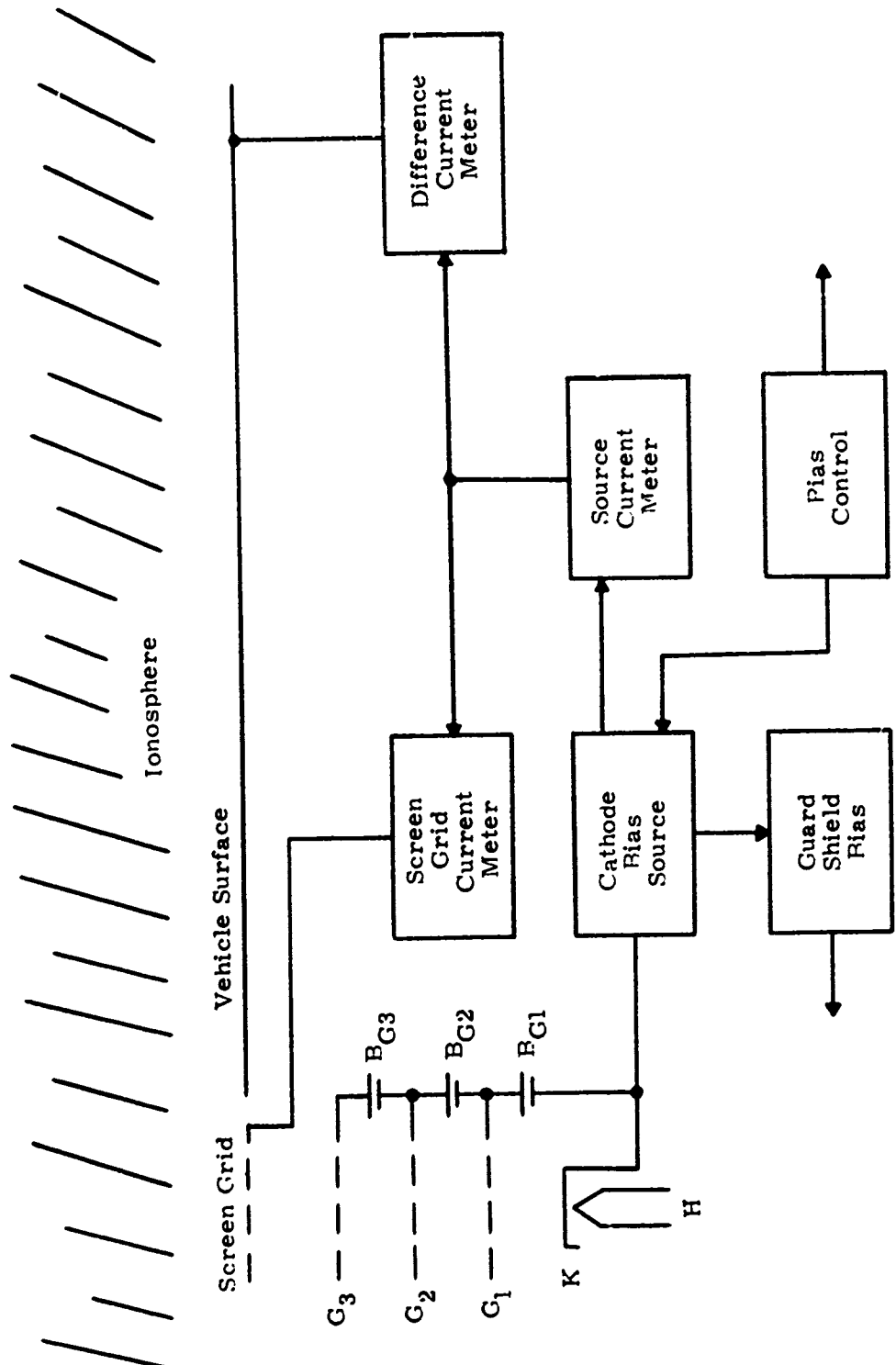

Fig. 1. Experiment Block Diagram





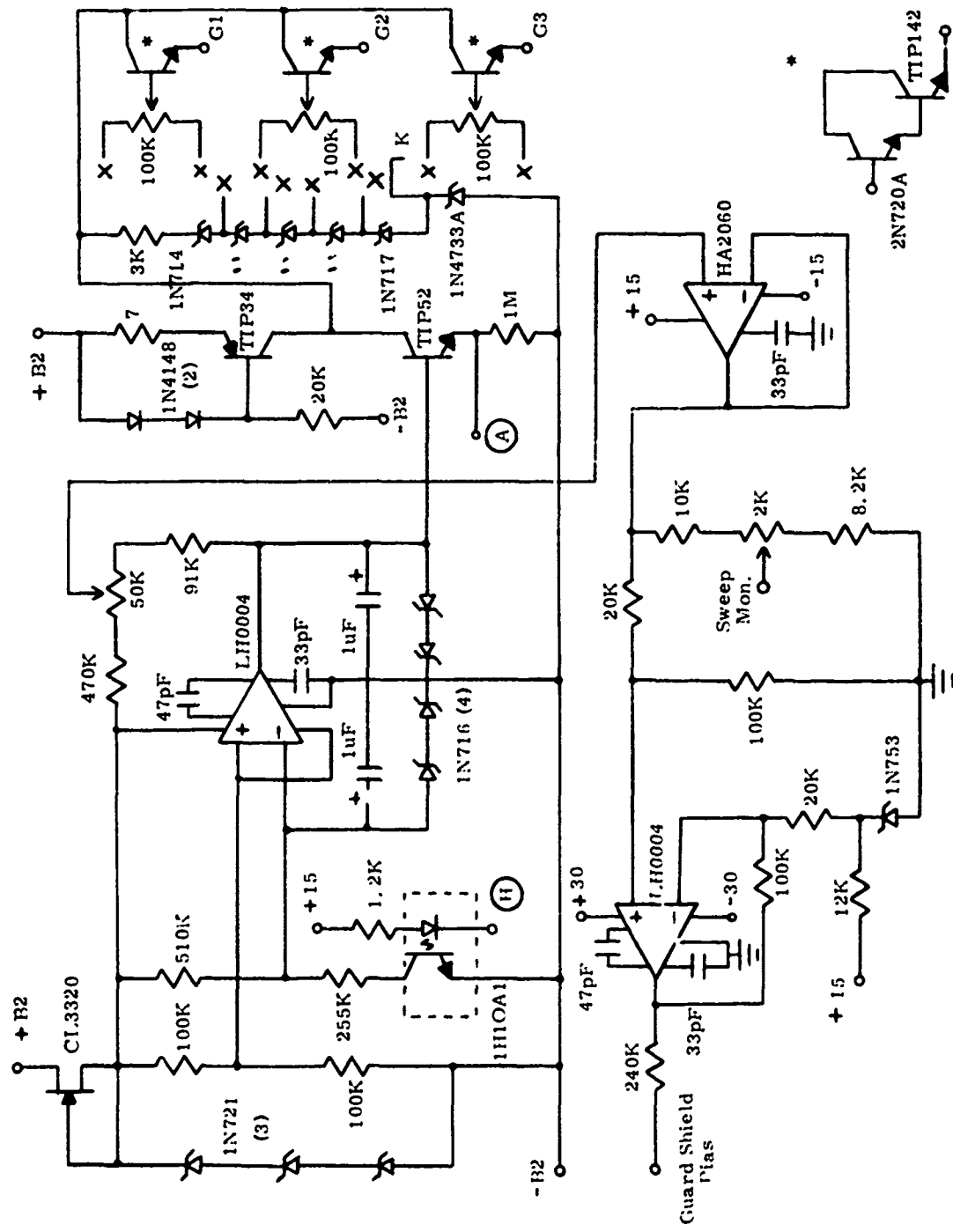
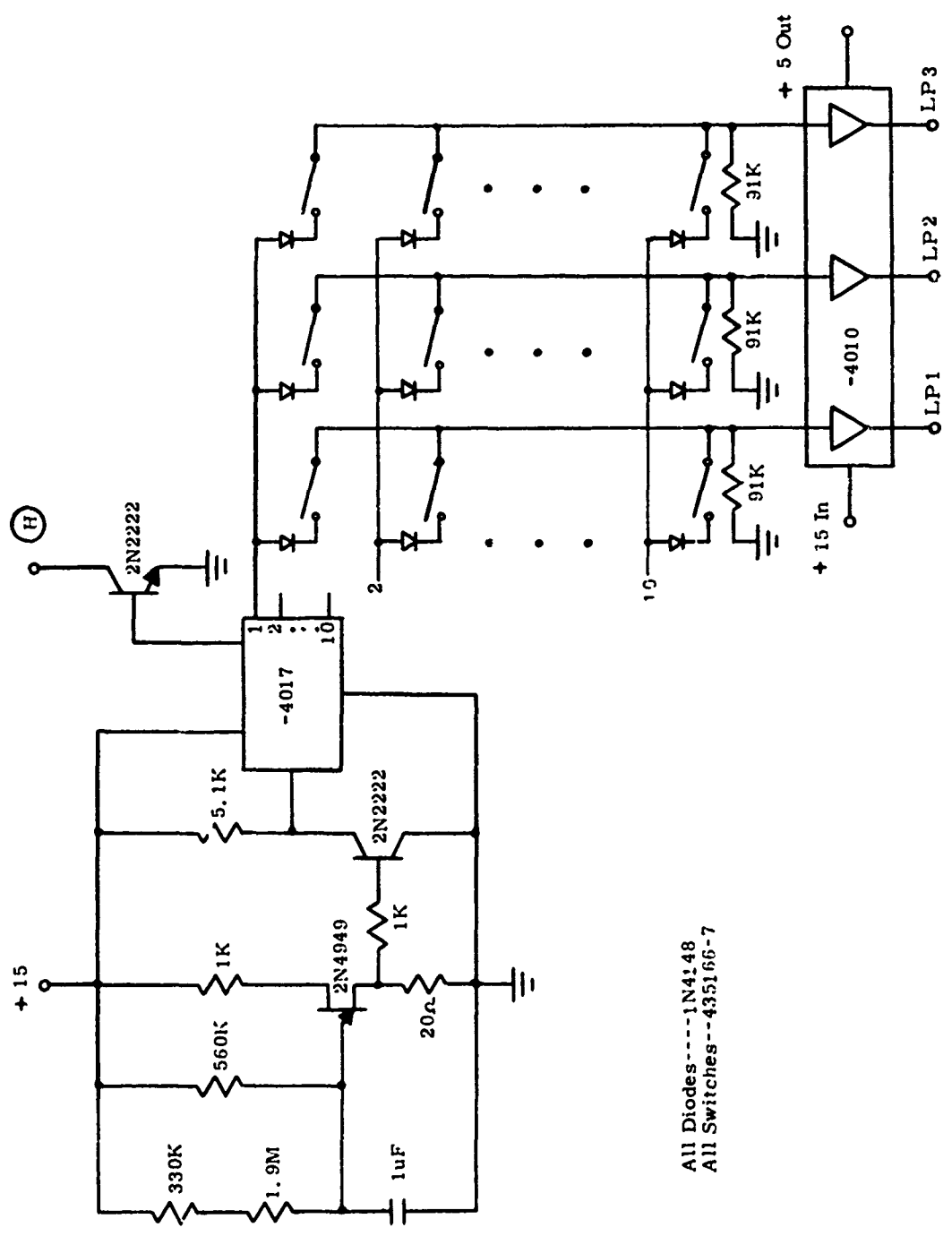

Fig. 4. Sweep Generator



All Diodes----1N4148  
 All Switches--435166-7

Fig. 5. Control Circuits

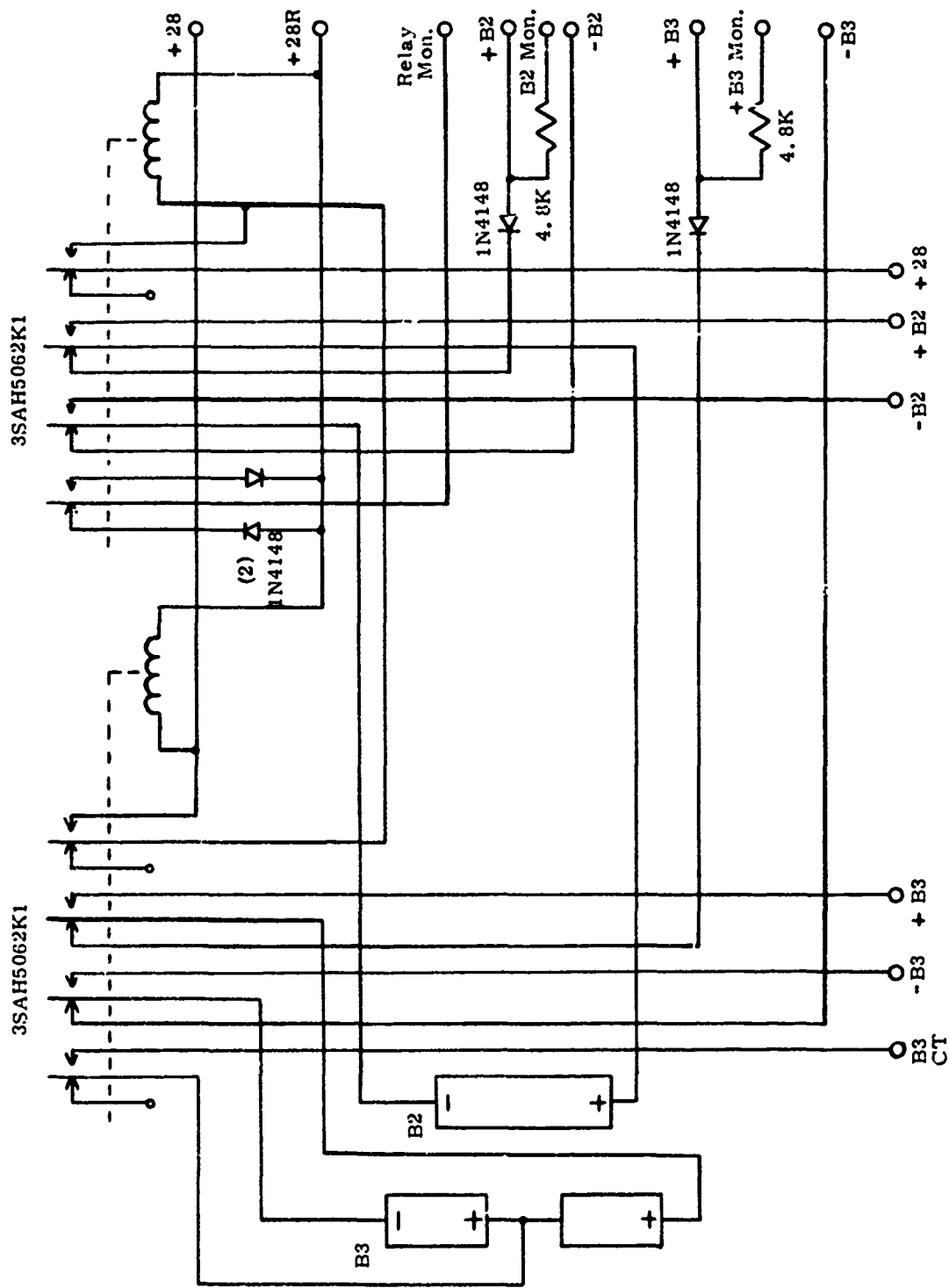
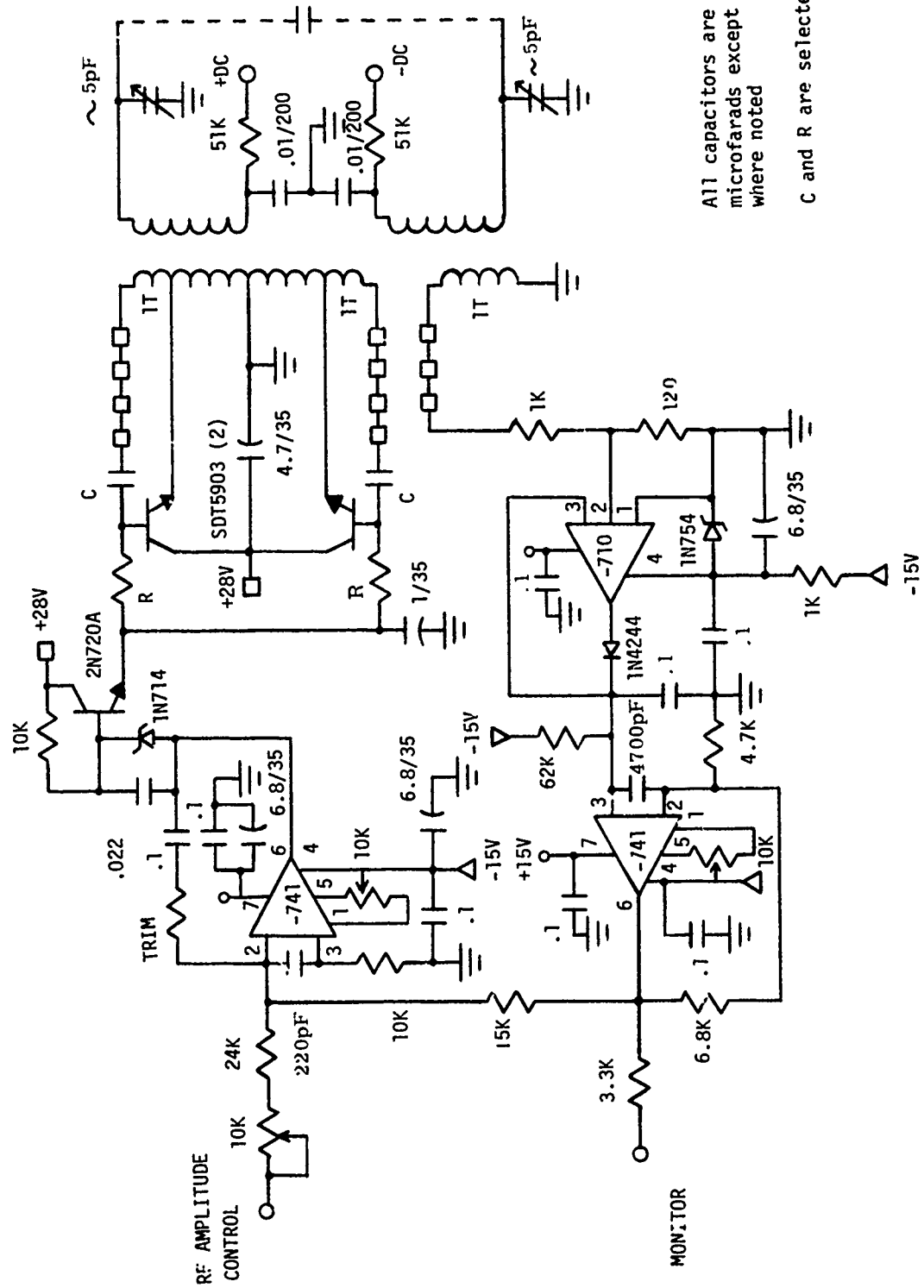

Fig. 6. Power Transfer and Monitor Circuits





All capacitors are in microfarads except where noted

C and R are selected

Fig. 8. RF Oscillator

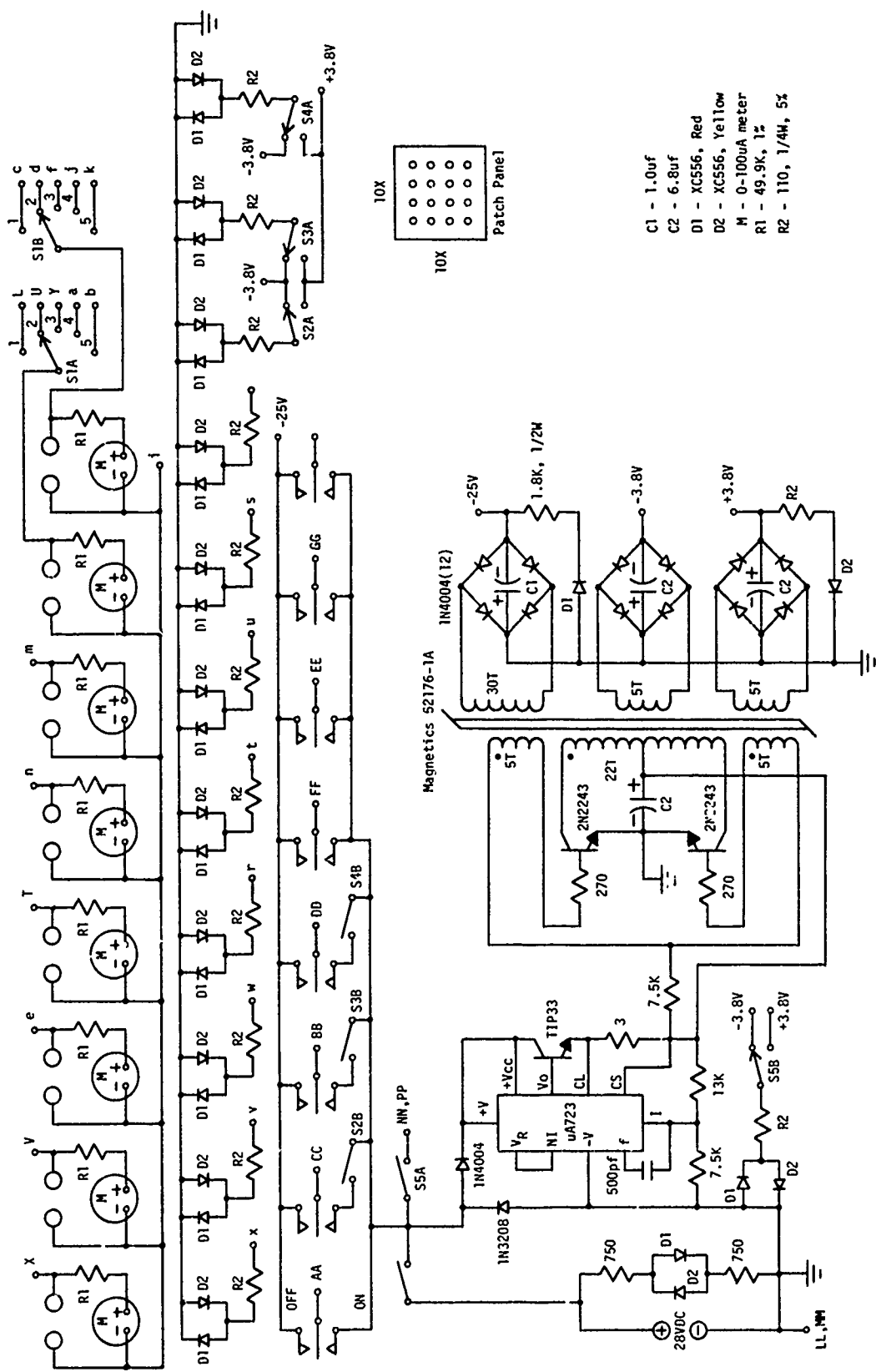

Fig. 9. Test and Control Circuits