

AD-A011 449

FLIGHT TEST EVALUATION OF AVOID I (AVIONIC  
OBSERVATION OF INTRUDER DANGER) COLLISION  
AVOIDANCE SYSTEM

J. Hinds, et al

Naval Air Development Center

Prepared for:

Federal Aviation Administration

May 1975

DISTRIBUTED BY:

**NTIS**

National Technical Information Service  
U. S. DEPARTMENT OF COMMERCE

189160

REPORT NO. NADC-75056-60

ADA011449



**FLIGHT TEST EVALUATION OF AVOID 1  
COLLISION AVOIDANCE SYSTEM**

J. Hinds and O. Shames  
Naval Navigation Laboratory  
NAVAL AIR DEVELOPMENT CENTER  
Warminster, Pennsylvania 18974

MAY 1975

FINAL REPORT  
INTERAGENCY AGREEMENT  
DOT-FA73-WAI-358

*APPROVED FOR PUBLIC RELEASE; DISTRIBUTION UNLIMITED.*

Reproduced by  
NATIONAL TECHNICAL  
INFORMATION SERVICE  
U.S. Department of Commerce  
Springfield, VA 22151

Prepared for  
FEDERAL AVIATION ADMINISTRATION  
Department of Transportation  
Washington, D. C. 20591  
and  
NAVAL AIR SYSTEMS COMMAND  
Department of the Navy  
Washington, D. C. 20361

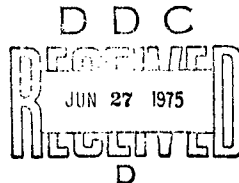

UNCLASSIFIED

SECURITY CLASSIFICATION OF THIS PAGE (When Data Entered)

REPORT DOCUMENTATION PAGE		READ INSTRUCTIONS BEFORE COMPLETING FORM
1. REPORT NUMBER NADC-75056-60	2. GOVT ACCESSION NO.	3. RECIPIENT'S CATALOG NUMBER AD-A011 449
4. TITLE (and Subtitle) FLIGHT TEST EVALUATION OF AVOID I (AVIONIC OBSERVATION OF INTRUDER DANGER) COLLISION AVOIDANCE SYSTEM		5. TYPE OF REPORT & PERIOD COVERED Final Report
		6. PERFORMING ORG. REPORT NUMBER
7. AUTHOR(s) J. Hinds O. Shames		8. CONTRACT OR GRANT NUMBER(s)
9. PERFORMING ORGANIZATION NAME AND ADDRESS Naval Navigation Laboratory (Code 60) Naval Air Development Center Warminster, Pa. 18974		10. PROGRAM ELEMENT, PROJECT, TASK AREA & WORK UNIT NUMBERS 60000 N DOT-FA73-WAI-358 N. T. F. KZ701
11. CONTROLLING OFFICE NAME AND ADDRESS Federal Aviation Administration (Code ARD-241) Department of Transportation Washington, D. C. 20591		12. REPORT DATE May 1975
		13. NUMBER OF PAGES 309
14. MONITORING AGENCY NAME & ADDRESS (if different from Controlling Office) Naval Air Systems Command (AIR 53353) Department of the Navy Washington, D. C. 20361		15. SECURITY CLASS. (of this report) Unclassified
		16a. DECLASSIFICATION/DOWNGRADING
16. DISTRIBUTION STATEMENT (of this Report) APPROVED FOR PUBLIC RELEASE; DISTRIBUTION UNLIMITED.		
17. DISTRIBUTION STATEMENT (of the abstract entered in Block 20, if different from Report) D D C DECLASSIFIED JUN 27 1975 RECEIVED D		
18. SUPPLEMENTARY NOTES		
19. KEY WORDS (Continue on reverse side if necessary and identify by block number) CAS Airborne Collision Avoidance System AVOID Separation Assurance		
20. ABSTRACT (Continue on reverse side if necessary and identify by block number) AVOID is a candidate for a national standard collision avoidance system. A comprehensive flight and laboratory evaluation of the AVOID I version was conducted including the ability to communicate accurately and with sufficient distance to provide timely and correct advisories and maneuver commands in simulated high traffic density.		

DD FORM 1473  
1 JAN 73EDITION OF 1 NOV 65 IS OBSOLETE  
S/N 0102-014-66011

UNCLASSIFIED

SECURITY CLASSIFICATION OF THIS PAGE (When Data Entered)

SUMMARY

A. INTRODUCTION

Historically, the technical community has attempted to develop an effective CAS (Collision Avoidance System) for aircraft for over fifteen years. Early attempts were dismal failures; only in the last few years has the technology been available to devise a CAS which satisfies performance, cost and size requirements.

One potential solution is a system known as AVOID (Avionic Observation of Intruder Danger). This is a family of equipments designed by Honeywell for all types of cooperating aircraft. The AVOID I is the equipment type designated for the larger military aircraft and for the majority of the commercial carriers.

The AVOID I tested was an engineering prototype packaged in a 1/2 short ATR equipment case which approaches a 3/8 short ATR production configuration. This report documents the flight test evaluation of the AVOID I CAS.

The FAA (Federal Aviation Administration) has been directed by the U. S. Congress to report on CAS progress and to arrive at a decision for a National CAS Plan. In support of Department of Defense involvement in that decision, the Navy is performing certain test and evaluation functions for the AVOID family of equipments. The work reported herein was jointly sponsored by the Department of Transportation and the Department of Defense.

The AVOID concept evolved out of a series of Proximity Warning Systems (culminating in the YG 1054) which Honeywell developed for the Army and of which there are approximately 1500 in operational use. One system - the YG 1031 Collision Warning System - provides the pilot with relative sector bearing to the intruder aircraft. This demonstrated capability was not an AVOID I requirement.

In November 1972, the FAA, Navy and the Naval Air Development Center entered into an agreement (reference (1)) for the procurement and subsequent laboratory and flight testing of the AVOID I equipment. The contract (reference (2)) for the purchase of three AVOID I systems and associated traffic simulators, calibration generators and digital interfaces was executed in January 1973 and the AVOID I equipments were delivered in January 1974. Flight and laboratory evaluation covered the period from

February 1974 to November 1974. Approximately three months of interruptions were required for design changes to correct deficiencies uncovered by NAVAIRDEVCECEN during the early flight test phase.

## B. OBJECTIVES

The general objective of this test program was to evaluate the potential of the AVOID concept to perform the collision avoidance function as described in ANTC 117 (reference (3)).

An important goal was the gathering of test data to assure the availability of common parameters for comparison with competing systems. This was accomplished through a series of laboratory and flight tests. The laboratory tests included the measurement of link and receiver sensitivities, co-range target interference, the effect of traffic on data communication and false alarms, range and range rate measurement, threat logic and round time. The flight tests were performed with fruit injected to determine:

1. The communication range as a function of the angle between flight paths.
2. The display reliability and the effectiveness of the air-to-air data link.
3. The accuracy of the range and range rate.
4. The ability to provide timely and correct advisories and maneuver commands.

## C. SUMMARY OF RESULTS

The AVOID I provided the necessary avoidance warnings to the pilots. The warnings were consistent with the requirements of ANTC 117, and provided the pilots with sufficient time to execute the necessary avoidance maneuvers.

The required communication range was exceeded for all encounter angles at the speeds shown, and for all extrapolated 1200 knot range rates above 10,000 feet for all of the flights involving the NC 117 vs. either the RA-3B or P-3. The same results were achieved for all of the flights involving the RA-3B above the P-3. For the flights involving the P-3 above the RA-3B, the communication ranges were marginal when extrapolated to a 1200 knot range rate, above 10,000 feet, at encounter angles of -120 and 180 degrees.

The pilot display reliability was 98.2%.

The air to air data link when operating with fruit in accordance with Appendix A had an error rate which was too high and caused an excessive number of false alarms.

The range and range rate accuracies (Theodolite reference) were:

GROUP	RANGE		RANGE RATE	
	MEAN %OF RANGE	SIGMA FEET	MEAN KNOTS	SIGMA KNOTS
All Data	+2.5	154	+10	11
Data Without Fruit	+2.7	132	+ 9	10
Data With Fruit*	+2.1	197	+13	13

\*Predicted fruit rate in Appendix A.

#### D. CONCLUSIONS

The AVOID concept has the potential for performing the collision avoidance function as described in ANTC-117.

The TAU TWO communication range was sufficient for encounters with range rates extrapolated up to 1200 knots, except for a marginal range for the P-3 above the A-3 aircraft at encounter angles of 180° and -120°. This indicates that antenna locations may have to be carefully chosen on some types of aircraft. TAU ONE communications range was sufficient.

The round/display communications reliability was satisfactory in the maximum aircraft density predicted by Honeywell simulations of the Los Angeles basin in 1982 (Appendix A). These simulations provided for every aircraft in the model being equipped with a CAS which provides the pilot with evasive maneuver commands. All IFR aircraft (15% of the aircraft) were equipped with the AVOID I CAS; all VFR aircraft (85% of the aircraft) were equipped with the AVOID II CAS.

The air-to-air data link error rate was too high with fruit in accordance with Appendix A and resulted in an unacceptable rate of false alarms. Technical interchanges initiated by NAVAIRDEVCON with Honeywell culminated in the issuance of the NAVAIRDEVCON AVOID II Requirements Document (Appendix B). This resulted in an AVOID II design which should have a satisfactory

false alarm rate. It is anticipated that a similar design augmented by some additional techniques should yield a satisfactory false alarm rate for the AVOID I.

The range and range rate accuracies were satisfactory.

The round and warning times were satisfactory.

The incidence of altered alarms due to altitude scale factors was excessive. This is being corrected in both AVOID I and AVOID II equipments.

#### E. RECOMMENDATIONS

It is recommended that TAU TWO and TAU ONE threats be identified by range and range rate before being processed through the display logic to preclude the display of a threat resulting from two fruit tracks (false alarm) or one fruit track followed by a legitimate track (early alarm).

It is recommended that the two interrogation sets in the branch altitude bands be increased to five or more. This is to reduce to an acceptable level, the probability of fruit falling within the altitude correlation range acceptance gate, causing an alteration of an advisory or command.

It is recommended that the same powerful fruit suppression logic that is applied to intruders having altitude differentials less than 1300 feet be applied to intruders having altitude differentials greater than 1300 feet to reduce the false alarms associated with the higher altitude differential regime and to provide a uniform update rate for all types of threats.

It is recommended that 50 foot range bins be implemented for the entire range of the CAS to reduce the formation of fruit tracks and fruit correlation in the branch altitude bands with its attendant false alarms.

It is recommended that the altitude code scaling factor be changed from 1 nanosecond per foot to 2 nanoseconds per foot so that the 100 ft. digitizing accuracy of the altimeter can be preserved in establishing altitude threat boundaries.

It is recommended that the interrogation multipath altitude response guard gate be increased from 5 microseconds to 10 microseconds to be compatible with the revised altitude scale factor of 2 nanoseconds per foot. However, a preferable solution would

NADC-75056-60

be to incorporate an adaptive multipath guard gate referenced to the multipath of the first pulse pair of an interrogation quad as devised by NAVAIRDEVGEN.

It is recommended that additional sets of interrogations be incorporated in the interrogation sequence to prevent the formation of phantom intruder tracks which cause false alarms.

It is recommended that clock pulses be used to generate the range bins and that the clock frequency be increased to provide bins which are precisely 50 feet wide so that the inherent range resolution of the system is realized and can be demonstrated.

It is recommended that consideration be given to changing the interrogation quadruplet to a 500 ns, 700 ns; 600 ns, 800 ns sextuplet to further increase the fruit margin with respect to false alarms.

## TABLE OF CONTENTS

	Page
SUMMARY .....	i
A. Introduction .....	i
B. Objectives .....	ii
C. Summary of Results .....	ii
D. Conclusions .....	iii
E. Recommendations .....	iv
LIST OF FIGURES .....	ix
LIST OF TABLES .....	xv
CHAPTER I. EQUIPMENT DESCRIPTION .....	1
Interrogation and Response Timing .....	1
Tau Threat Evaluation Criteria .....	1
Interrogation and Evaluation Sequence .....	13
Altitude Response Bands .....	16
Typical Sequence .....	22
Hardware Configuration .....	25
CHAPTER II. AIRCRAFT INSTALLATION AND FLIGHT TEST INSTRUMENTATION .....	30
Aircraft Installation .....	30
Traffic Simulator .....	31
Digital Display and Interface (DDI) .....	37
Computer Print-Out of In-Flight Data .....	40
CHAPTER III. LABORATORY TESTS .....	50
Introduction .....	50
Receiver Sensitivity .....	50
Power Budget .....	53
Range and Range Rate Errors .....	53
Round Time .....	56
Threat Logic .....	56

## TABLE OF CONTENTS (Continued)

	Page
CHAPTER IV. FLIGHT TEST PLAN SUMMARY .....	59
Introduction .....	59
Communication Reliability Tests .....	59
Sensor Accuracy Tests .....	62
Operational Tests .....	62
CHAPTER V. AVOID I MODIFICATIONS INCORPORATED DURING FLIGHT TESTS .....	67
Introduction .....	67
False Alarms Due to Multipath .....	67
False Alarms Due to Improper Altitude Correlation at High Closing Rates Below 9600 Feet .....	71
False Alarms Due to Crosstalk Between Receiving Channels at High Signal Levels .....	74
Missed Alarms and False Alarms Caused by Pulse Stretching of the Interrogations .....	75
CHAPTER VI. COMMUNICATION RANGE AND RELIABILITY .....	77
Introduction .....	77
Communication Range - P3 Versus RA-3B Flights .....	84
Communication Range - P3 Versus NC 117 Flights .....	96
Communication Range - RA-3B Versus NC 117 Flights..	106
Round and Display Reliability .....	109
Introduction .....	109
Reliability - P3 Versus RA-3B Flights .....	110
Reliability - P3 Versus NC 117 Flights .....	134
Reliability - RA-3B Versus NC 117 Flights .....	162
Summary .....	169
1. Communication Range .....	169
2. Round and Display Communication Reliability .....	175
CHAPTER VII. RANGE, RANGE RATE, AND WARNING TIME ACCURACIES .....	181
Introduction .....	181
Range and Range Rate Accuracies .....	185
Warning Time Accuracy .....	190

## TABLE OF CONTENTS (Continued)

	Page
CHAPTER VIII. FALSE ALARMS .....	209
Introduction .....	209
General Background .....	210
Phantom Intruder Alarms Due to Fruit .....	211
Conditional Alarm Alteration Due to Fruit .....	216
Conditional Alarm Alteration Due to Altitude Scaling Factors .....	221
Conditional Alarm Alteration Due to a Co-Range Situation .....	224
False Alarm Flight Narrative .....	226
Conclusions .....	229
CHAPTER IX. SUMMARY OF RESULTS .....	234
REFERENCES .....	238
BIBLIOGRAPHY .....	239
APPENDICES .....	240

## LIST OF FIGURES

Figure	Title	Page
I-1	Interrogation and Response Timing Diagram ...	2
I-2	Tau Filter Criteria .....	10
I-3	Tau Register Loading (Altitude <9600 Feet) ..	12
I-4	Altitude Response Bands .....	17
I-5	Interrogation Sequence .....	23
I-6	Avoid I Outline Drawing .....	26
I-7	Avoid I With Cover Removed .....	27
I-8	Avoid I Complete With CAS/VSI Indicator ....	28
I-9	CAS/VSI Indicator in Test Mode .....	29
II-1	CAS Antenna Locations of P-3A .....	32
II-2	CAS Antenna Locations NC-117 .....	33
II-3	CAS Antenna Locations RA-3B .....	33
II-4	Traffic Simulator Front Panel .....	34
II-5	Engineering Display/Digital Interface Front Panel .....	39
II-6	Block Diagram of DDI and System Interfaces ..	41
II-7	System Interconnect Diagram .....	42
II-8	Avoid I - DDI Data Format for Recorder Interface .....	43
II-9	Computer Print-Out of In-Flight Data - Section 1 .....	45
II-10	Computer Print-Out of In-Flight Data - Section 2 .....	46
III-1	Link Sensitivity Test Set-Up .....	51
III-2	Range Rate Error Versus Fruit Rate .....	55
III-3	Range Error Versus Fruit Rate .....	57
IV-1	Communication Reliability, Single Daisy Over a Figure Eight .....	61
IV-2	WST Range - Controlled Area .....	63
V-1	Conditional Phantom Intruder Alarm Due to Multipath .....	69
V-2	Conditional Alarm Alteration Due to Multipath .....	72
V-3	Interrogation Format - Original and as Modified to Solve Pulse Stretching Problem .....	76
VI-1	Communication Reliability Single Daisy Over a Figure Eight .....	78
VI-2	Geometric Limitations, NC 117 Versus P-3A ...	81
VI-3	Geometric Limitations, RA-3B Versus P-3A ....	82
VI-4	RA3B Antenna Look Angle Versus Angle Between Radials Flown .....	85

## LIST OF FIGURES (Continued)

Figure	Title	Page
VI-5	P-3A Antenna Look Angle Versus Angle Between Radials Flown .....	86
VI-6	Communication Range, Flight 4, P-3A Above RA-3B .....	87
VI-7	Communication Range, Flight 12, P-3A Versus RA-3B, Head-On Encounters .....	89
VI-8	Communication Range Histogram for P-3A Above RA-3B .....	90
VI-9	Communication Range, Flight 12, P-3A Above RA-3B, Tail Chase Encounter .....	91
VI-10	Communication Range, Flight 9, RA-3B Above P-3A .....	93
VI-11	Communication Range, Flight 11, RA-3B Above P-3A .....	94
VI-12	Communication Range Histogram for RA-3B Above P-3A for Head-On Encounters .....	96
VI-13	Communication Range, Flights 4 and 12, P-3A Above RA-3B .....	97
VI-14	Communication Range, Flights 9, 11, and 12, RA-3B Above P-3A .....	98
VI-15	Communication Range, Flight 6, P-3A Above NC-117 .....	99
VI-16	Communication Range, Flight 7, P-3A Above NC-117 .....	101
VI-17	Communication Range, Flight 7, NC-117 Above P-3A .....	102
VI-18	Communication Range, Flight 9, P-3A Above NC-117 .....	104
VI-19	Communication Range, Flight 11, P-3A Above NC-117 .....	105
VI-20	Communication Range, Flights 9 and 11, P-3A Above NC-117 .....	107
VI-21	Communication Range, Flights 9 and 11, RA-3B Above NC-117 .....	108
VI-22	Round Reliability Versus Encounter Angle, Flight 4, P-3A Above RA-3B .....	111
VI-23	Round Reliability, Flight 4, P-3A Above RA-3B .....	113
VI-24	Display Reliability Versus Encounter Angle, Flight 4, P-3A Above RA-3B .....	114
VI-25	Display Reliability, Flight 4, P-3A Above RA-3B .....	116

## LIST OF FIGURES (Continued)

Figure	Title	Page
VI-26	Round Reliability, Flight 12, RA-3B Tail Chase of P-3A From Below .....	117
VI-27	Round Reliability, Flight 12, Equivalent P-3A Tail Chase of RA-3B From Above .....	118
VI-28	Display Reliability, Flight 12, RA-3B Tail Chase of P-3A From Below .....	119
VI-29	Round Reliability Versus Encounter Angle, Flight 9, RA-3B Above P-3A .....	120
VI-30	Round Reliability, Flight 9, RA-3B Above P-3A .....	122
VI-31	Display Reliability Versus Encounter Angle, Flight 9, RA-3B Above P-3A .....	123
VI-32	Display Reliability, Flight 9, RA-3B Above P-3A .....	124
VI-33	Simultaneous P-3A Display Reliability, Flight 9, Three Aircraft Encounters .....	125
VI-34	Round Reliability Versus Encounter Angle, Flight 11, RA-3B Above P-3A .....	126
VI-35	Round Reliability, Flight 11, RA-3B Above P-3A .....	128
VI-36	Display Reliability Versus Encounter Angle, Flight 11, RA-3B Above P-3A .....	129
VI-37	Display Reliability, Flight 11, RA-3B Above P-3A .....	130
VI-38	Round Reliability, Flight 12, RA-3B Above P-3A, Head-On Encounters .....	131
VI-39	Display Reliability, Flight 12, RA-3B Above P-3A, Head-On Encounters .....	132
VI-40	Display Reliability Versus Encounter Angle, Flights 9, 11, 12, RA-3B Above P-3A .....	133
VI-41	Display Reliability, Flights 9, 11, 12, RA-3B Above P-3A .....	135
VI-42	Display Reliability Versus Encounter Angle, Flights 4 and 12, P-3A Above RA-3B .....	136
VI-43	Display Reliability, Flights 4 and 12, P-3A Above RA-3B .....	137
VI-44	Round Reliability Versus Encounter Angle, Flight 6, P-3A Above NC-117 .....	138
VI-45	Round Reliability, Flight 6, P-3A Above NC-117 .....	140
VI-46	Display Reliability Versus Encounter Angle, Flight 6, P-3A Above NC-117 .....	141
VI-47	Display Reliability, Flight 6, P-3A Above NC-117 .....	142

## LIST OF FIGURES (Continued)

Figure	Title	Page
VI-48	Round Reliability Versus Encounter Angle, Flight 7, P-3A Above NC-117 .....	143
VI-49	Round Reliability, Flight 7, P-3A Above NC 117 .....	144
VI-50	Display Reliability Versus Encounter Angle, Flight 7, P-3A Above NC-117 .....	145
VI-51	Display Reliability, Flight 7, P-3A Above NC 117 .....	146
VI-52	Round Reliability Versus Encounter Angle, Flight 7, NC-117 Above P-3A .....	148
VI-53	Round Reliability, Flight 7, NC-117 Above P-3A .....	149
VI-54	Display Reliability Versus Encounter Angle, Flight 7, NC-117 Above P-3A .....	150
VI-55	Display Reliability, Flight 7, NC-117 Above P-3A .....	151
VI-56	Round Reliability Versus Encounter Angle, Flight 9, P-3A Above NC-117 .....	152
VI-57	Round Reliability, Flight 9, P-3A Above NC-117 .....	153
VI-58	Display Reliability Versus Encounter Angle, Flight 9, P-3A Above NC-117 .....	155
VI-59	Display Reliability, Flight 9, P-3A Above NC-117 .....	156
VI-60	Round Reliability Versus Encounter Angle, Flight 11, P-3A Above NC-117 .....	157
VI-61	Round Reliability, Flight 11, P-3A Above NC 117 .....	158
VI-62	Display Reliability Versus Encounter Angle, Flight 11, P-3A Above NC-117 .....	159
VI-63	Display Reliability, Flight 11, P-3A Above NC-117 .....	160
VI-64	Display Reliability Versus Encounter Angle, Flights 9 and 11, P-3A Above NC-117 .....	161
VI-65	Display Reliability, Flights 9 and 11, P-3A Above NC-117 .....	163
VI-66	Display Reliability Versus Encounter Angle, Flights 6, 7 (Part), 9 and 11, P-3A Above NC-117 .....	164
VI-67	Display Reliability, Flights 6, 7 (Part), 9 and 11, P-3A Above NC-117 .....	165
VI-68	Total Round Reliability, Flights 6, 7, 9 and 11, P-3A Versus NC-117 .....	166

## LIST OF FIGURES (Continued)

Figure	Title	Page
VI-69	Total Display Reliability, Flights 6, 7, 9 and 11, P-3A Versus NC-117 .....	167
VI-70	Round Reliability, Flight 9, RA-3B Above NC-117, -90° Encounters .....	168
VI-71	Display Reliability, Flight 9, RA-3B Above NC-117, -90° Encounters .....	170
VI-72	Round Reliability, Flight 11, RA-3B Above NC-117, -90° Encounters .....	171
VI-73	Display Reliability, Flight 11, RA-3B Above NC-117, -90° Encounters .....	172
VI-74	Total Round Reliability, Flights 9 and 11, RA-3B Above NC-117, -90° Encounters .....	173
VI-75	Total Display Reliability, Flights 9 and 11, RA-3B Above NC-117, -90° Encounters .....	174
VI-76	Total Round Reliability, for all Communication Reliability Flights .....	176
VI-77	Total Display Reliability, for all Communication Reliability Flights .....	177
VI-78	Total Round Reliability for all Communication Reliability Flights of P-3A Versus RA-3B .....	179
VI-79	Total Display Reliability for all Communication Reliability Flights of P-3A Versus RA-3B .....	180
VII-1	Range Bin Widths Versus Range .....	186
VII-2	Tau One and Tau Two Thresholds .....	191
VII-3	Tau Two Warning Time Histogram .....	193
VII-4	Tau One Warning Time Histogram .....	194
VII-5	Warning Time Distribution - Earliest of an Alarm Pair .....	197
VII-6	Cumulative Warning Time Distribution for Earliest Alarm of an Alarm Pair .....	198
VII-7	Avoid Tau 2 Measurement Error Histogram .....	200
VII-8	Avoid Tau 1 Measurement Error Histogram .....	201
VII-9	Flight Profiles of Warning Time History Plots .....	203
VII-10	Warning Time History of 356 Tau Two Alarms .....	204
VII-11	Warning Time History of the Earliest Tau 2 Alarm of an Alarm Pair .....	205
VII-12	Warning Time History of 312 Tau One Alarms ..	206
VII-13	Warning Time History of the Earliest Tau 1 Alarm of Each Alarm Pair .....	207

LIST OF FIGURES (Continued)

Figure	Title	Page
VIII-1	Conditional and Phantom False Alarm Rates Versus Fruit Rate .....	212
VIII-2	Present and Proposed Interrogation Form .....	233

## LIST OF TABLES

Table	Title	Page
I-1	Range Data Accumulator Bin Widths .....	3
I-2	Tau Zone 1 - Threat Evaluation .....	4
I-3	Maximum Bin Crossings as a Function of Range (MKBSB) .....	6
I-4	Tau Zone 2 - Threat Evaluation .....	8
I-5	Interrogation Decision Logic .....	15
I-6	Altitude Interrogation Codes .....	18
I-7	Altitude Threat Band Logic .....	20
II-1	Antenna Locations .....	31
II-2	Altitude Threat Boundary Check-Out Procedures for Altitude Regime Above 9500 Feet .....	36
II-3	Computer Print-Out Nomenclature .....	47
III-1	Link Sensitivities of All the Possible Link Combinations of the Three Avoid I Equip- ments With Fruit .....	52
III-2	Receiver Reply and Transponding Sensitivities..	54
III-3	Measured Round Times .....	56
IV-1	Theodolite Flight Test Profiles .....	64
IV-2	CAS/VSI Displays Associated With Altitude Boundary Penetration .....	65
V-1	Flight Over Water Showing Effect of Multipath Phantom Intruders .....	70
V-2	Phantom Intruder Alarms and Alarm Altera- tions Due to Multipath .....	73
VII-1	Range, Range Rate and Tau Data for Head-On Encounter (437 Knots) on Theodolite Range ...	183
VII-2	Range - Range Rate Error Statistics .....	188
VIII-1	Phantom False Alarms in Level Flight With No Intruders .....	213
VIII-2	Phantom False Alarms in Ascending Flight at 700 F.P.M. With No Intruders .....	217
VIII-3	Conditional False Alarms in Ascending Flight at 700 F.P.M. With Intruder at 2000 Feet ....	218
VIII-4	Conditional Alarm Alteration Modes 2 and 3 ....	220
VIII-5	Conditional False Alarms in Level Flight, Co-Altitude Intruder .....	222
VIII-6	Summary of In-Flight False Alarms (Predominantly Level Flight Mode 1) .....	230

## CHAPTER 1

## EQUIPMENT DESCRIPTION

## INTERROGATION AND RESPONSE TIMING

The AVOID I CAS is a single frequency interrogator transponder equipment operating at 1607.5 MHz  $\pm$ 15 MHz with a 130 nanosecond pulse width and a 15 nanosecond rise time. The interrogation and response timing are shown in Figure I-1. An interrogation consists of a pulse quadruple - the first pair separated by 500ns. is followed by a second pair separated by 600ns. The separation of the two pulse pairs is proportional to the altitude band interrogated (own altitude plus bias altitude) and a fixed 32.5  $\mu$ s delay for multipath suppression. In the predicted co-altitude band, the bias altitude is also a function of altitude rate. Responses to interrogations are single pulses. The replying aircraft determines if his own altitude is within  $\pm$  700 feet of the interrogated altitude; if it is he responds, if it is not he does not respond.

Range to the intruder aircraft is determined by the position of the reply pulse in a range bin and range rate to the intruder by bin crossing pattern recognition through logical implementation of the collision threat equations. The bin widths associated with the various range intervals are shown in Table I-1. In the range interval 0 to 4.9 NM, 50 ft. bin widths are used for high resolution of the minimum range criteria of 0.5 NM and for all TAU 1 threats below 9,600 ft. Beyond 4.9 NM the bin widths increase gradually to 168 feet, the maximum for subsonic encounters, and to 472 feet for two supersonic aircraft on a head-on collision course.

## TAU THREAT EVALUATION CRITERIA

Table I-2 gives the TAU 1 threat evaluation criteria in terms of minimum numbers of bins skipped for encounters in which the range between aircraft is decreasing with time and the maximum number of bins skipped ( $L_{+19}$ ) for encounters in which the range between aircraft is increasing where "L" is the location of a target in a bin of the A register at the start of a 3.2 second epoch. Below 9,600 feet in altitude, the maximum numbers of bin crossing permissible is 56 (Table I-3) at a closing rate of 923 feet per second. By way of illustration, if a target is below 9,600 ft. and is at a range of 6,550 ft. and skips between 11 and 56 bins, he is evaluated as being in the TAU 1 Zone. The theoretical range rate ( $\dot{R}$ ) for this range is 186 feet per second. The column marked  $\dot{R}$  minimum 157 ft./sec., gives the value of  $\dot{R}$  below which the threat criteria will not be met. The column marked  $\dot{R}$  reject, 193 ft./sec. gives the value of  $\dot{R}$  above which the threat criteria will be met. Values of  $\dot{R}$  between these two limits may or may not

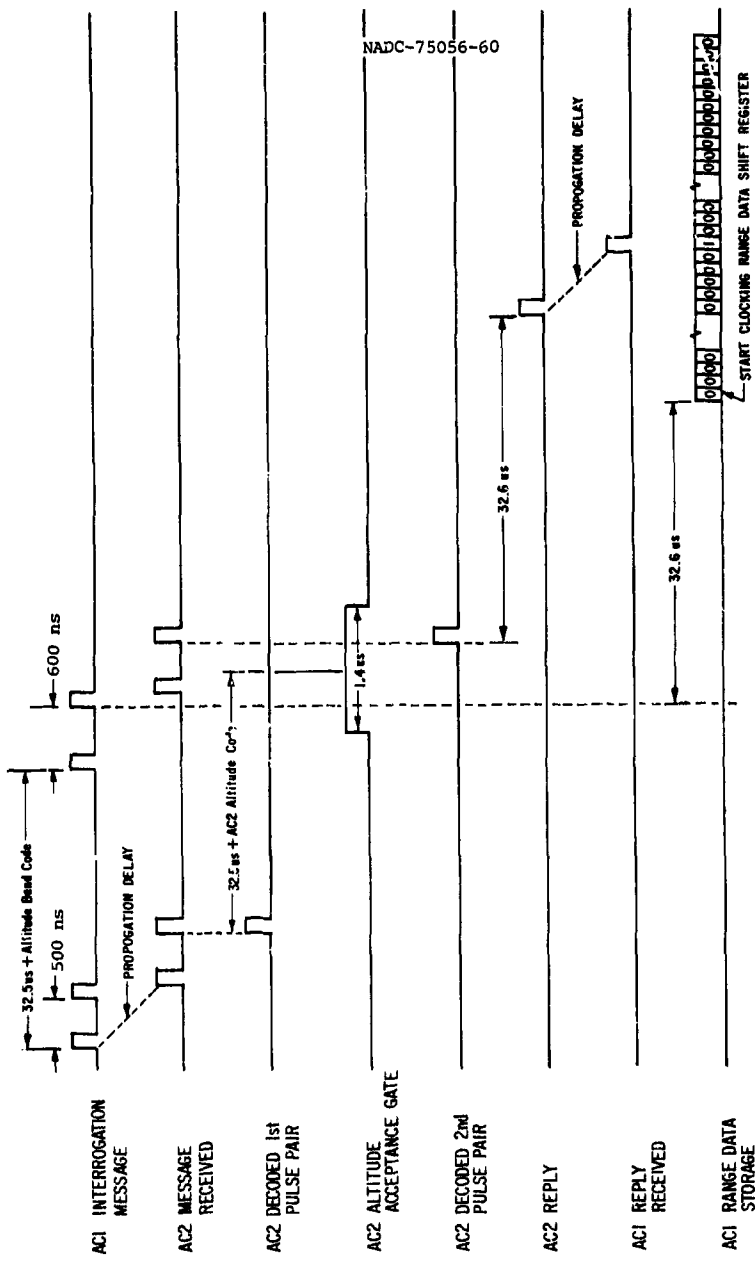

NOTE: Altitude Band Code = 1.0ns/ft to Band Center referenced to 1200 ft below Sea Level.

Figure I-1. Interrogation and Response Timing Diagram.

TABLE I-1. RANGE DATA ACCUMULATOR BIN WIDTHS

<u>Range Interval</u>	<u>Bin Width</u>	<u>Number of Bins</u>	<u>Total Bins (Cumulative)</u>
0. - 29700.	50	594	594
29700. - 32292.	54	48	642
32292. - 35124.	59	48	690
35124. - 38244.	65	48	738
38244. - 41652.	71	48	786
41652. - 45348.	77	48	834
45348. - 49380.	84	48	882
49380. - 53796.	92	48	930
53796. - 58596.	100	48	978
58596. - 63780.	108	48	1026
63780. - 69444.	118	48	1074
69444. - 75684.	130	48	1122
75684. - 82500.	142	48	1170
82500. - 89892.	154	48	1218
89892. - 97956.	168	48	1266
97956. - 106788.	184	48	1314
106788. - 116388.	200	48	1362
116388. - 126756.	216	48	1410
126756. - 138084.	236	48	1458
138084. - 150564.	260	48	1506
150564. - 164196.	284	48	1554
164196. - 178980.	308	48	1602
178980. - 195108.	336	48	1650
195108. - 212772.	368	48	1698
212772. - 231972.	400	48	1746
231972. - 252708.	432	48	1794
252708. - 275364.	472	48	1842

## NADC-75056-60

TABLE I-2. TAU ZONE 1 - THREAT EVALUATION (T1/T2 BSB)

<u>Range Interval</u>	<u>Bin Width</u>	<u>Threat Criteria</u>	<u>Rdesired</u>	<u>Rminimum</u>	<u>Rreject</u>
0 - 3000	50	L+19	-	-	-
3000 - 3550	50	L- 4	60	40	77
3550 - 4000	50	L- 5	82	57	93
4000 - 4450	50	L- 6	100	73	110
4450 - 4850	50	L- 7	118	90	127
4850 - 5300	50	L- 8	134	107	143
5300 - 5750	50	L- 9	152	123	160
5750 - 6150	50	L-10	170	140	177
6150 - 6600	50	L-11	186	157	193
6600 - 7050	50	L-12	204	173	210
7050 - 7450	50	L-13	222	190	227
7450 - 7900	50	L-14	238	207	243
7900 - 8350	50	L-15	256	223	260
8350 - 8750	50	L-16	274	240	277
8750 - 9200	50	L-17	290	257	293
9200 - 9650	50	L-18	308	273	310
9650 - 10050	50	L-19	326	290	327
10050 - 10500	50	L-20	342	307	343
10500 - 10950	50	L-21	360	323	360
10950 - 11350	50	L-22	378	340	377
11350 - 11800	50	L-23	394	357	393
11800 - 12250	50	L-24	412	373	410
12250 - 12650	50	L-25	430	390	427
12650 - 13100	50	L-26	446	407	443
13100 - 13550	50	L-27	464	423	460
13550 - 13950	50	L-28	482	440	477
13950 - 14400	50	L-29	498	457	493
14400 - 14850	50	L-30	516	473	510
14850 - 15250	50	L-31	534	490	527
15250 - 15700	50	L-32	550	507	543
15700 - 16150	50	L-33	568	523	560
16150 - 16550	50	L-34	586	540	577
16550 - 17000	50	L-35	602	557	593
17000 - 17450	50	L-36	620	573	610
17450 - 17850	50	L-37	638	590	627
17850 - 18300	50	L-38	654	607	643
18300 - 18750	50	L-39	672	623	660
18750 - 19150	50	L-40	690	640	677
19150 - 19600	50	L-41	706	657	693
19600 - 20050	50	L-42	724	673	710
20050 - 20450	50	L-43	742	690	727
20450 - 20900	50	L-44	758	707	743
20900 - 21350	50	L-45	776	723	760
21350 - 21750	50	L-46	794	740	777
21750 - 22200	50	L-47	810	757	793
22200 - 22650	50	L-48	828	773	810
22650 - 23050	50	L-49	846	790	827

TABLE I-2. TAU ZONE 1 - THREAT EVALUATION (T1/T2 BSB) (Cont.)

<u>Range Interval</u>	<u>Bin Width</u>	<u>Threat Criteria</u>	<u>Rdesired</u>	<u>Rminimum</u>	<u>Rreject</u>
23050 - 23500	50	L-50	862	807	843
23500 - 23950	50	L-51	880	823	860
23950 - 24350	50	L-52	898	840	877
24350 - 24800	50	L-53	914	857	893
24800 - 25250	50	L-54	932	873	910
25250 - 25650	50	L-55	950	890	927
25650 - 26100	50	L-56	966	907	943
26100 - 26550	50	L-57	984	923	960
26550 - 26950	50	L-58	1002	940	977
26950 - 27300	50	L-59	1018	957	993
27300 - 29700	50	L-60	1032	973	1017
29700 - 32292	54	L-60	1128	1052	1090
32292 - 35124	59	L-60	1232	1150	1190
35124 - 38244	65	L-60	1345	1268	1310
38244 - 41652	71	L-60	1470	1386	1430
41652 - 45348	77	L-60	1606	1504	1550
45348 - 49380	84	L-60	1754	1642	1690
49380 - 53796	92	L-60	1915	1799	1850
53796 - 58596	100	L-60	2092	1957	2010
58596 - 63780	108	L-60	2284	2114	2170
63780 - 69444	118	L-60	2491	2311	2370
69444 - 75684	130	L-60	2718	2547	2610
75684 - 82500	142	L-60	2967	2783	2850
82500 - 89892	154	L-60	3240	3019	3090
89892 - 97956	168	L-60	3536	3294	3370
97956 - 106788	184	L-60	3858	3609	3690
106788 - 116388	200	L-60	4212	3923	4010
116388 - 126756	216	L-60	4596	4238	4330
126756 - 138084	236	L-60	5010	4631	4730
138084 - 150564	260	L-60	5463	5103	5210
150564 - 164196	284	L-60	5963	5575	5690
164196 - 178980	308	L-60	6508	6047	6170
178980 - 195108	336	L-60	7099	6598	6730
195108 - 212772	368	L-60	7744	7227	7370
212772 - 231972	400	L-60	8451	7857	8010
231972 - 252708	432	L-60	9219	8486	8650
252708 - 275364	472	L-60	10048	9273	9450

TABLE I-3. MAXIMUM BIN CROSSINGS  
 AS A FUNCTION OF RANGE (MXBSB)  
 (ALTITUDE <9600 FEET)

<u>Range Interval</u>	<u>Bin Width</u>	<u>Threat Criteria</u>	<u>R<sub>maximum</sub></u>
0 - 29700	50	L-56	923 fps
29700 - 32292	54	L-53	944
32292 - 35124	59	L-50	973
35124 - 38244	65	L-47	1008
38244 - 41652	71	L-44	1031
41652 - 45348	77	L-41	1042
45348 - 49380	84	L-38	1054

\* For aircraft operating above 9500 ft. altitude,  
 the acceptance criteria is a constant L<sub>-126</sub>.

result in the threat criteria being met. Thus  $\hat{R}$  minimum and  $\hat{R}$  reject are tolerances on meeting the threat criteria due to rf jitter, aircraft acceleration, and digitization of the range intervals into discrete bin widths. Table I-4 gives the threat evaluation criteria for TAU Zone 2; for altitude differential  $>1300$  feet the epoch time is 6.5 seconds but the evaluation period is 3.2 seconds. It is found in Table I-4 that the target at 6,550 ft. will be a TAU 1 or TAU 2 threat if it has a minimum bin skip opening of  $L_{+6}$  or a maximum bin skip closing of  $L_{-56}$  over a 3 second period. The  $L_{+6}$  bin skip opening represents a skip of six 50 ft. bins (300 ft.) in 3 seconds or an opening rate of 100 ft./sec.; the  $L_{-56}$  bins closing is a skip of fifty six 50 ft. bins (2,800 ft.) in 3 seconds or a closing rate of 933 ft./sec.

Let us assume that the range to the intruder is determined every 0.5 second and the results are stored in seven shift registers A through G. Referring to Figure I-2 "L" represents the location of the target in the A register at a range of 6,550 ft. The TAU 2 or TAU 1 threat possibilities can then be represented by bin skips from the A to the G register ranging from  $L_{+6}$  to  $L_{-56}$  for a total of 63 possible threatening tracks for the single given target in the A register (for clarity only every other track is shown). On successive interrogations at 0.5 second intervals, the target replies must fit one of the 63 possible threatening tracks for the given initial range within a range tracking gate tolerance of three to four bin widths in registers B through F inclusive or the target is not considered to be a threat. The tolerance allows for bin splitting, pulse rise time, aircraft acceleration, pulse jitter and clock timing. A proper fit results in the declaration of a TAU threat for the altitude band considered. The categorization of the threat as TAU 1 or TAU 2 is accomplished by counting the number of bins skipped from the A to G register; a bin skip of  $L_{+6}$  to  $L_{-10}$  is a TAU 2 threat, and a bin skip of  $L_{-11}$  to  $L_{-56}$  is a TAU 1 threat. The TAU filter and altitude correlation is implemented by means of seven memory registers A through G (2048 bit shift registers) for each of the basic altitude bands ( $I_{+26}$ ,  $I_{+13}$ ,  $I_{+6}$ ) to store intruder responses. Since the  $I_{+13}$  and the  $I_{+25}$  and,  $I_{-13}$  and  $I_{-25}$  bands are used on alternate sequences, the memory registers for these bands are shared. Two sets of E and G memory registers are provided for the  $I_{+4}$  and  $I_{-4}$  bands and one set of E and G registers for the  $I_{PCA}$  and  $I_{PCB}$  bands since these bands are never used together.

Associated with every memory register is a TAU filter register. Basically these are transfer registers in which the responses in the memory registers can be operated on to evaluate whether they form a threatening track without disturbing the time relationships in the memory registers. The contents of the memory registers are shifted into the TAU filter registers so that the closest target in the A register is at the output of the TAU filter A register. As their respective sub-epochs occur, the contents of the B through G memory registers are shifted an identical amount into their respective TAU filter registers to maintain the same relative range relationship in the TAU filter registers as they had in the memory registers. During the TAU evaluation process of one target in

TABLE I-4. TAU ZONE 2 - THREAT EVALUATION

<u>Range Interval</u>	<u>Bin Width</u>	<u>Threat Criteria</u>	<u>Rdesired</u>	<u>Rminimum</u>	<u>Rreject</u>
3000 - 3700	50	L+11	-195	-210	-173
3700 - 4400	50	L+10	-177	-193	-157
4400 - 5100	50	L+ 9	-160	-177	-140
5100 - 5800	50	L+ 8	-142	-160	-123
5800 - 6500	50	L+ 7	-125	-143	-107
6500 - 7200	50	L+ 6	-107	-127	-90
7200 - 7900	50	L+ 5	-90	-110	-73
7900 - 8600	50	L+ 4	-73	-93	-57
8600 - 9300	50	L+ 3	-55	-77	-40
9300 - 10000	50	L+ 2	-37	-60	-23
10000 - 10700	50	L+ 1	-20	-43	-7
10700 - 11400	50	L 0	-3	-27	10
11400 - 12100	50	L- 1	15	-10	27
12100 - 12800	50	L- 2	33	7	43
12800 - 13500	50	L- 3	50	23	60
13500 - 14200	50	L- 4	68	40	77
14200 - 14900	50	L- 5	85	57	93
14900 - 15600	50	L- 6	102	73	110
15600 - 16300	50	L- 7	120	90	127
16300 - 17000	50	L- 8	138	107	143
17000 - 17700	50	L- 9	155	123	160
17700 - 18400	50	L-10	172	140	177
18400 - 19100	50	L-11	190	157	193
19100 - 19800	50	L-12	207	173	210
19800 - 20500	50	L-13	225	190	227
20500 - 21200	50	L-14	242	207	243
21200 - 21900	50	L-15	260	223	260
21900 - 22600	50	L-16	277	240	277
22600 - 23300	50	L-17	295	257	293
23300 - 24000	50	L-18	313	273	310
24000 - 24700	50	L-19	330	290	327
24700 - 25400	50	L-20	347	307	343
25400 - 26100	50	L-21	365	323	360
26100 - 26800	50	L-22	382	340	377
26800 - 27300	50	L-23	400	357	393
27300 - 29700	50	L-23	413	357	393
29700 - 32292	54	L-24	472	404	442
32292 - 35124	59	L-25	537	462	502
35124 - 38244	65	L-26	608	532	573
38244 - 41652	71	L-27	686	605	649
41652 - 45348	77	L-28	771	683	729
45348 - 49380	84	L-29	864	774	822
49380 - 53796	92	L-30	964	879	930
53796 - 58596	100	L-31	1075	990	1043
58596 - 63780	108	L-31	1195	1070	1126
63780 - 69444	118	L-32	1324	1209	1269
69444 - 75684	130	L-32	1466	1333	1397

TABLE I-4. TAU ZONE 2 - THREAT EVALUATION (Cont.)

<u>Range Interval</u>	<u>Bin Width</u>	<u>Criteria</u>	<u>Rdesired</u>	<u>Rminimum</u>	<u>Rreject</u>
75684 - 82500	142	L-33	1622	1505	1572
82500 - 89892	154	L-33	1792	1633	1704
89892 - 97956	168	L-34	1977	1838	1914
97956 - 106788	184	L-34	2179	2014	2095
106788 - 116388	200	L-35	2400	2257	2343
116388 - 126756	216	L-35	2640	2438	2530
126756 - 138084	236	L-35	2899	2665	2763
138084 - 150564	260	L-35	3182	2937	3043
150564 - 164196	284	L-36	3494	3303	3418
164196 - 178980	308	L-36	3835	3583	3706
178980 - 195108	336	L-36	4204	3910	4042
195108 - 212772	368	L-36	4608	4283	4426
212772 - 231972	400	L-37	5049	4790	4943
231972 - 252708	432	L-37	5529	5174	5338
252708 - 275364	472	L-37	6048	5654	5831

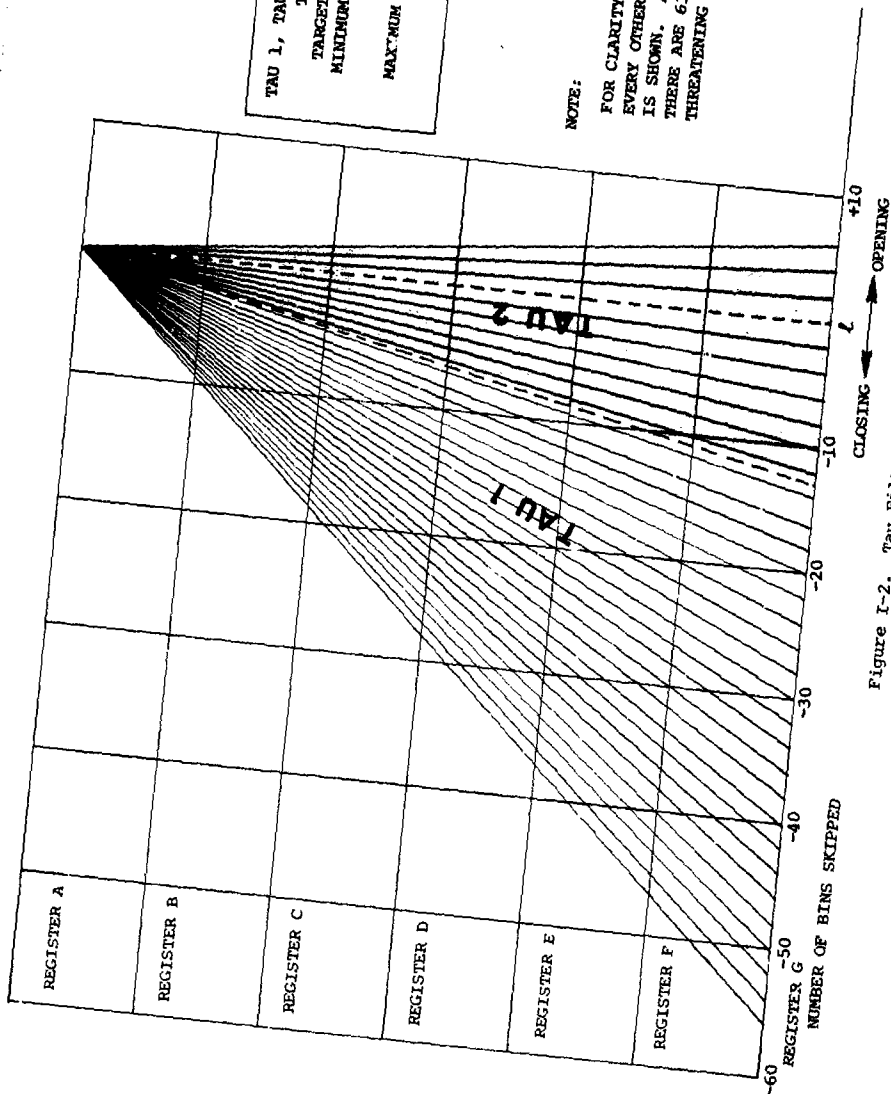

TAU 1, TAU 2 THREATENING  
TRACKS  
TARGET AT 6550'  
MINIMUM BIN SKIP  
L-46  
MAXIMUM BIN SKIP  
L-56

NADC-75056-60

NOTE:

FOR CLARITY, ONLY  
EVERY OTHER TRACK  
IS SHOWN. ACTUALLY,  
THERE ARE 63 POSSIBLE  
THREATENING TRACKS.

Figure I-2. Tau Filter Criteria.

in the A register the contents of the B through G TAU filter registers are recirculated so that at the end of an evaluation interval the responses in these registers are restored to the original range relationship for use with subsequent more distant targets in the A register.

The TAU 1/TAU 2 bin skip boundary (T1/T2 BSB), the minimum bin skip boundary (MNBSB) and the maximum bin skip boundary (MXBSB) for a target moving from the A to G register are shifted into two registers, J and K, as a function of the range to the intruder in the A register under evaluation. The J register is used to categorize targets as TAU 1, and the K register is used to categorize targets as TAU 1 or TAU 2; both registers are equal in length to the G register. At the start of an evaluation cycle, the J and K registers are pre-loaded with 1's and 0's in accordance with the threat limits for an intruder at zero range (see Tables I-2, I-3, and I-4). As a target in the A memory register is shifted into the TAU filter A register, a range (R) counter keeps track of the number of shifts (which is directly correlatable to range to the target) that were necessary to place the target in the TAU filter A register. The counter output code then controls the threat limit boundaries by changing the output state of the J and K registers as they are recirculated prior to target evaluation. Since the threat limit boundary changes in the J and K registers do not occur synchronously as the range to the target increases, separate controls are required.

Figure I-3 shows the loading of the J and K registers for targets below 9,600 ft. altitude. In the target range interval of 0 - 2950 ft. the initial pre-load of the J and K registers is seen to extend from target locations relative to the A register of L<sub>419</sub> (the MNBSB) to L<sub>56</sub> (the MXBSB) which corresponds to J and K register bin numbers 5 through 80. Since a TAU 2 threat does not exist in the range interval 0 - 2950 ft., the loading of the J and K registers is identical. Thus when a target track is established in the A through G registers within the bin skip criteria of L<sub>419</sub> to L<sub>56</sub> bins, 1's will appear at the output of all registers when the responses in the G, J and K registers are shifted between 70 and 145 bins and the target is classified as a TAU 1 threat. Response shifts between 0 to 69 and 146 to 150 are outside of the threat limits and result in "0's" at the output of the J and K registers indicating that the target is not a threat. The G, J and K register length of 150 bins is to accommodate bin skips of up to L<sub>126</sub> in the above 9600 ft. altitude regime.

If the first target appears at a range of 3400 ft., the R counter increments to a count of 67 which falls in the 3000 to 3500 ft. target range interval (Figure I-3b). Prior to the evaluation of a target, the J and K registers are recirculated to their original loading. The R counter control causes the "1" states at the output of the J register to be changed to "0" states for 23 shifts, from the 122nd to the 145th shift; on the 150th shift the recirculation is complete and the J register has 1's over the interval L<sub>4</sub> to L<sub>56</sub>, 0's elsewhere. The K register is loaded similarly with the "1" states at the output of the K registers changed to "0" states for 8 shifts from the 137th to 145th shifts.

TARGET RANGE

0-2950 ft { fifty-nine 50' counts } TAU 1 L<sub>+19</sub> to L<sub>-56</sub>  
 TAU 1/TAU 2 L<sub>+19</sub> to L<sub>-56</sub>

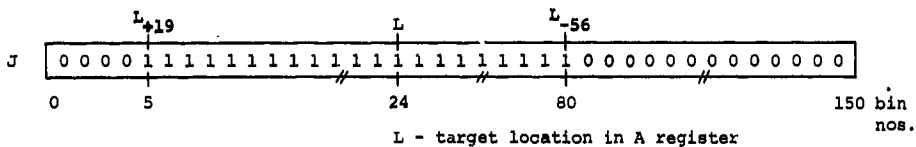

FIGURE I-3a.

3000-3500' { sixty to sixty-nine } TAU 1 L<sub>-4</sub> to L<sub>-56</sub>  
 { 50' counts from } TAU 1/TAU 2 L<sub>+11</sub> to L<sub>-56</sub>  
 { zero range }

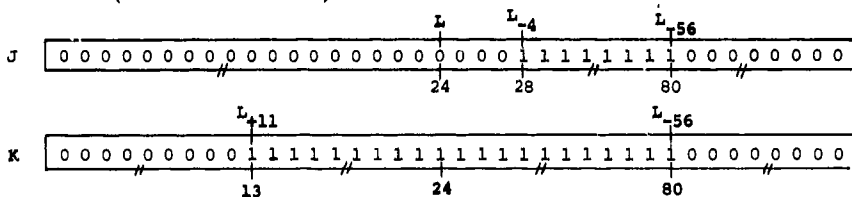

FIGURE I-3b.

3550'-3700' { seventy to seventy-three } TAU 1 L<sub>-5</sub> to L<sub>-56</sub>  
 { 50' counts from zero range } TAU 1/TAU 2 L<sub>+11</sub> to L<sub>-56</sub>

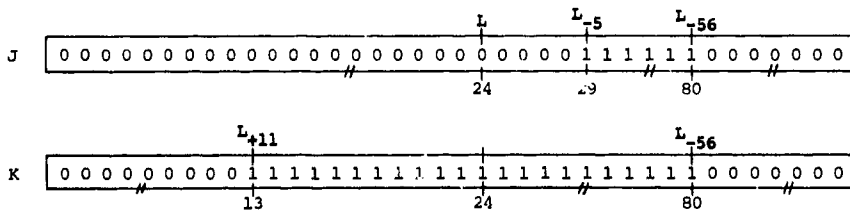

FIGURE I-3c.

FIGURE I-3 - J AND K TAU REGISTER LOADING  
 (ALTITUDE < 9600 FEET)

Figure I-3c. shows that in the target range interval of 3550 to 3700 ft. the J register loading is changed to reduce the TAU 1 threat interval by one bin while the K register loading remains the same.

Important to the determination of whether an intruder is on a threatening track or not is whether the intruder has skipped approximately an equal number of bins during each 0.5 second sub-epoch. This is accomplished for every target in the TAU filter A register by shifting the contents in each TAU filter register B through G to the end of their respective registers by means of a six phase clock and by making the lengths of the registers in the ratio of 1:2:3:4:5:6, G being the longest. The clock shifts the B TAU filter register at one-sixth the rate ( $\phi_1$ ) of the G register, the C register at two sixths the rate ( $\phi_2$ ), the D register at three-sixths the rate ( $\phi_3$ ), the E register at four-sixths the rate  $\phi_4$ , the F register at five-sixths the rate  $\phi_5$  and the G register at the full rate  $\phi_6$ . Thus, if the intruder responses in the B through G registers when shifted by the six phase clock, arrive at the output of their respective registers simultaneously (within one or two bins in the B to F registers) and the bin skip boundaries have not been exceeded as indicated by a 1 at the output of the J and K registers, the intruder is declared a TAU threat (TAU 1 if the output of the J and K registers are 1's, TAU 2 if the output of the J register is a '0' and the output of the K register is a '1'). A variable tracking gate width for the B through F registers is accomplished by the shifting process through the A through G registers under the control of the six phase clock.

If a TAU evaluation with a particular target in the A register yields no threat, a more distant target is shifted from the A memory register to the output of the TAU filter A register with corresponding shifts of the B through G memory registers into their corresponding TAU filter registers. Some of the responses already in these TAU filter registers will now be shifted out of the TAU filter registers. However, the TAU filter registers are long enough to retain all of the responses in the B through G registers which could form a threatening TAU track with a given target in the A register.

Once a TAU track is established in every sub-epoch for one of the targets in the TAU filter A register, then all of the targets in the TAU filter A register and A memory register are evaluated one at a time. During each sub-epoch evaluation all of the TAU filter registers subsequent to the current sub-epoch (for example registers C through G for sub-epoch B) are filled with 1's. A coincidence of "1's" is required as a condition for continuation of interrogations in that 3 second sequence.

#### INTERROGATION AND EVALUATION SEQUENCE

To illustrate how the interrogation and evaluation sequence is mechanized, a typical situation with a target at 6550 ft. closing at 400 ft/sec and 300 ft. above own aircraft's altitude in level flight will be described. A sequence is started by completing all of the interrogations required in sub-epoch A in accord-

ance with the interrogation decision logic in Table I-5 storing the responses to each altitude band in their respective memory registers. Then the evaluation sequence commences with the  $I_{+6}$  altitude band. In sub-epoch A a 400 KHZ clock  $\phi_2$  makes 131 shifts ( $131 \times 50 = 6550$  ft.) to shift the target response out of the  $I_{+6}$  memory register into the output of the TAU filter A register. Simultaneously the J and K register bin skip limits are set up after each shift by reference to a counter comparator. At the 131st shift the J register is filled with 1's from  $L_{-11}$  (T1/T2 BSB) to  $L_{-56}$  (MXBSB) bin locations, 0's elsewhere and the K register is filled with 1's from  $L_{+6}$  (MNBSB) to  $L_{+56}$  (MXBSB) bin locations, 0's elsewhere. Since an intruder response in the A register is a sufficient condition to continue the evaluation of the intruder, the interrogation logic is enabled for the  $I_{+6}$  interrogation in sub-epoch B. The foregoing process is repeated for the  $I_{-6}$  altitude bands in sub-epoch A (the  $I_{+13}$  and  $I_{+25}$  altitude bands are not evaluated since the aircraft is in level flight).

Again, in sub-epoch B, all of the interrogations are made as required by the decision logic of Table I-5 based on the results of the sub-epoch A evaluation, the responses to each altitude band being stored in their respective memory registers. Then an evaluation sequence commences with the  $I_{+6}$  altitude band. The shift clock makes 131 shifts in shifting the responses in the B memory register (now 4 bins closer in range) into the TAU filter B register at location  $L_{-4}$ . Then  $\phi_1$  clock shifts the target response to the end of the TAU filter B register placing a "1" at the output while the  $\phi_6$  clock shifts the bin skip limits in the J and K register at six times the rate. Since the bin skip of 4 in the B register multiplied by 6, (the rate of the  $\phi_6$  clock) is equal to 24 bin skips and is less than the 56 bin skips allowed, a "1" appears at the output of the K register. This together with the 1's at the output of the A and B registers and 1's at the outputs of the C through G registers (pre-loaded with 1's for sub-epoch B), satisfies the TAU filter correlation logic enabling interrogation of the  $I_{+6}$  altitude band in sub-epoch C.

If, during the shift from the B memory register to the TAU filter B register, a response had not been found in the  $\phi_1$  ( $L_{-4}$  to  $L_{-56}$ ) interval associated with the subject target in the A register  $I_{+6}$  in the appropriate interval for all other targets in the A register, interrogations would be inhibited in the  $I_{+6}$  altitude band for the remainder of the 3 second period of sequence 1. The foregoing process is repeated for the  $I_{-6}$  altitude band in sub-epoch B.

In sub-epoch C, all of the interrogations required by the decision logic are made and the responses to each altitude band are stored in their respective memory registers. Then an evaluation sequence commences with the  $I_{+6}$  altitude band. The shift clock makes 131 shifts in shifting the response in the C memory register (now 8 bins closer in range) into the TAU filter C register at location  $L_{-8}$ . Then the  $\phi_1$  clock shifts the target response to the end of the TAU filter B register while the  $\phi_2$  clock shifts the target response to the end of the C register. Since the ratio of the bin skips from A to B and A to C was 1:2, the target responses reach the end of their respective registers simultaneously and

TABLE I-5. INTERROGATION DECISION LOGIC

ALGORITHM	SEQUENCE I										SEQUENCE II										
	SET A	SET B	SET C	SET D	SET E	SET F	SET G	SET A	SET B	SET C	SET D	SET E	SET F	SET G	SET H	SET I	SET J	SET K	SET L	SET M	
I(+2)	0"	1(+2)	1(+2)	1(+2)	1(+2)	1(+2)	1(+2)	0"	0"	0"	0"	0"	0"	0"	0"	0"	0"	0"	0"	0"	0"
I(-2)	0"	0"	0"	0"	0"	0"	0"	0"	0"	0"	0"	0"	0"	0"	0"	0"	0"	0"	0"	0"	0"
I(0A)	0"	0"	0"	0"	[(-4), 8(1)] [(-4), 8(1)] [(-4), 8(1)]	0"	[(+8), 8(1)] [(+8), 8(1)] [(+8), 8(1)]	0"	0"	0"	0"	0"	0"	0"	0"	0"	0"	0"	0"	0"	0"
I(0B)	0"	0"	0"	0"	[(-4), 8(1)]	0"	[(+8), 8(1)]	0"	0"	0"	0"	0"	0"	0"	0"	0"	0"	0"	0"	0"	0"
I(+1)	0"	1(+1)	1(+1)	1(+1)	[(+8), 8(1)] [(+8), 8(1)]	1(+1)	[(+8), 8(1)] [(+8), 8(1)]	0"	0"	0"	0"	0"	0"	0"	0"	0"	0"	0"	0"	0"	0"
I(+)	0"	0"	0"	0"	1(+)	0"	1(+)	0"	0"	0"	0"	0"	0"	0"	0"	0"	0"	0"	0"	0"	0"
I(-1)	0"	0"	0"	0"	1(-)	0"	1(-)	0"	0"	0"	0"	0"	0"	0"	0"	0"	0"	0"	0"	0"	0"
I(-)	0"	0"	0"	0"	1(-)	0"	1(-)	0"	0"	0"	0"	0"	0"	0"	0"	0"	0"	0"	0"	0"	0"
I(0)	0"	0"	0"	0"	0"	0"	0"	0"	0"	0"	0"	0"	0"	0"	0"	0"	0"	0"	0"	0"	0"
I(+1)	0"	0"	0"	0"	0"	0"	0"	0"	0"	0"	0"	0"	0"	0"	0"	0"	0"	0"	0"	0"	0"
I(+)	0"	0"	0"	0"	0"	0"	0"	0"	0"	0"	0"	0"	0"	0"	0"	0"	0"	0"	0"	0"	0"
I(-1)	0"	0"	0"	0"	0"	0"	0"	0"	0"	0"	0"	0"	0"	0"	0"	0"	0"	0"	0"	0"	0"
I(-)	0"	0"	0"	0"	0"	0"	0"	0"	0"	0"	0"	0"	0"	0"	0"	0"	0"	0"	0"	0"	0"

R(1) = 500-2800 FT/MIN. CLIMB R(2) = 2800-6000 FT/MIN. CLIMB R(3) = 500-2800 FT/MIN. DIVE R(4) = 2800-6000 FT/MIN. DIVE

1's appear at their output.

Simultaneously the  $\phi_6$  clock shifts the limits in the J and K registers at three times the rate of the  $\phi_2$  clock. Since the 8 bin skip in the C register relative to the A register multiplied by 3 (the rate of the  $\phi_6$  clock relative to the  $\phi_2$ ) yields an equivalent bin skip of 24 (less than the  ${}^6_56$  bin skip allowed) a "1" appears at the output of the K register. This together with the 1's at the output of the A, B and C registers and 1's at the outputs of the D through G registers (pre-loaded with 1's for sub-epoch C) satisfies the TAU filter correlation logic enabling interrogation of the  $I_{+6}$  altitude band in sub-epoch D. The foregoing process is repeated in the  $I_{-6}$  altitude band in sub-epoch C.

Subsequent interrogation and evaluation sequences in sub-epochs D, E, F and G are similar to the foregoing sequence. In sub-epochs E and G if threatening tracks have been established in the  $I_{+6}$  band in the preceding epochs, D and F respectively, branch interrogations are made in the  $I_{+4}$ , and  $I_{+13}$  bands in accordance with the interrogation decision logic Table I-5 to determine the exact altitude threat status of the intruder.

In sub-epoch G all of the responses in the B to G registers associated with the subject target in the A register line up at the outputs of their respective registers together with "1's" in the J and K register, and a TAU 1 threat is declared. Then the next target in the A memory register (further in range) is shifted into the TAU filter A register and the responses in the B through G registers evaluated to determine if they co-exist with the A target on a threatening track. The TAU threat status of each target is then correlated with the altitude bands in which the target responded so that it can be determined which altitude threat band has been penetrated. The entire process is repeated until all of the target responses in the A memory register have been shifted into the TAU filter A register and evaluated one at a time with the responses in the B through G registers. Then all the targets in the  $I_{-6}$  altitude band are evaluated. Thus all the threats in the  $I_{+6}$  above and  $I_{-6}$  below altitude bands have been evaluated and classified as TAU 1 co-altitude, TAU 2 co-altitude or predicted co-altitude, or just a TAU 2 threat. These are then used as inputs to the final threat logic for two or three aircraft encounters whichever the case may be.

#### ALTITUDE RESPONSE BANDS

The AVOIDS determines intruder penetration of the ANTC-117 altitude boundaries by asking the intruder a series of logical questions concerning his altitude relative to received altitude encoded interrogations. As shown in Figure I-4, the scheme consists of a system of coarse and fine biasing of his own altitude encoded interrogations. A series of ten different biases are used. The rectangular blocks which encompass the interrogation bias value, represent the band in which the intruder will respond if his altitude is within  $\pm 700$  ft. of the biased altitude received via the interrogation code. Table I-6 lists the

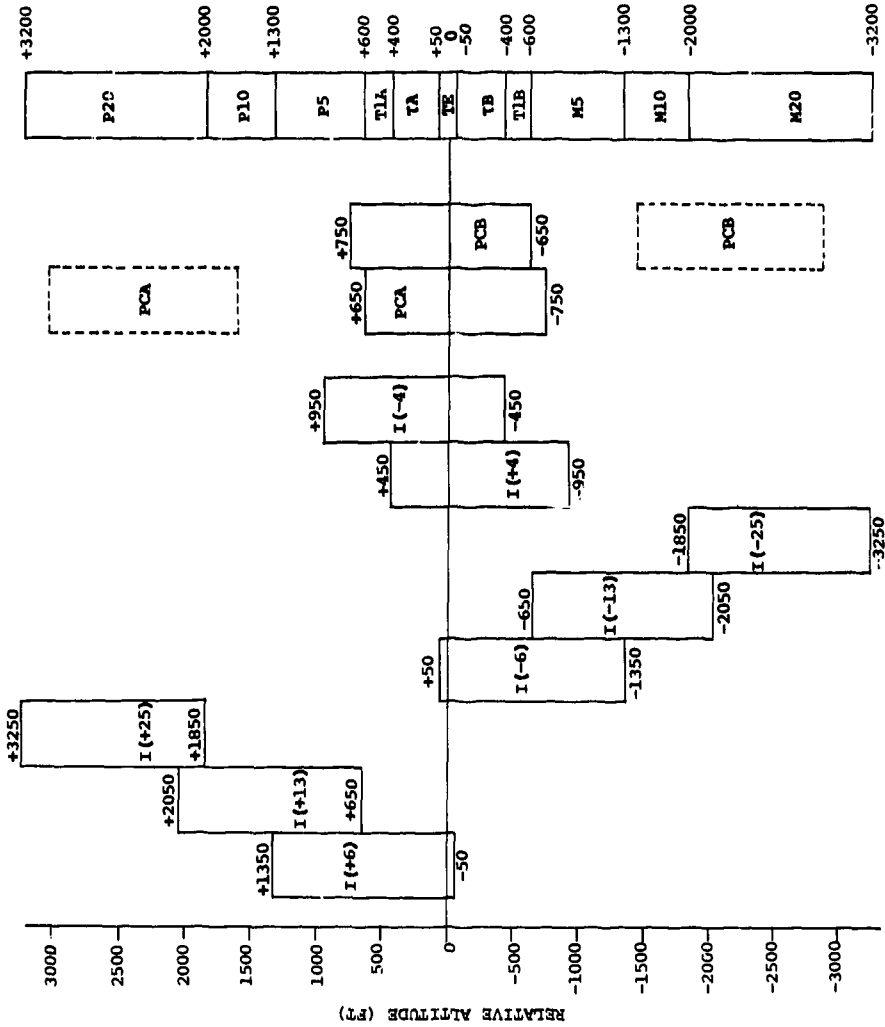

Figure I-4. Altitude Response Bands.

TABLE I-6 ALTITUDE INTERROGATION CODES  
(ALTITUDE <9600 FT.)

INTERROGATION CODE	BIAS ABOVE INTERROGATOR'S ALTITUDE FT	BIAS BELOW INTERROGATOR'S ALTITUDE FT
I+6	+650	
I-6		-650
I+13	+1350	
I-13		-1350
I+25	+2550	
I-25		-2550
I+4		-250
I-4	+250	

INTERROGATION CODE	BIAS, ABOVE OR BELOW INTERROGATOR'S ALTITUDE
I <sub>PCA</sub>	-50 + (0.5 x OWN RATE OF ASCENT) (FPM))
I <sub>PCB</sub>	+50 - (0.5 x OWN RATE OF DESCENT (FPM))

## NOTE:

ABOVE 9500 FT ALTITUDE:

I+13 AND PCA BIAS IS INCREMENTED 200 FT

I-13 AND PCB BIAS IS DECREMENTED 200 FT

interrogation codes together with the associated bias above or below the interrogators altitude for altitudes less than 9600 ft. Above 9500 ft. the  $I_{+13}$  and PCA bias is incremented 200 ft. and the  $I_{-13}$  and PCB decremented 200 ft. It will be noted that the  $I_{+6}$ ,  $I_{+13}$  and  $I_{+25}$  codes when multiplied by 100 are equal to the bias  $\pm 50$  ft. The  $I_{+4}$  codes when multiplied by 100 are equal to the bias  $\pm 650$  ft. The reason for these differences will be explained later in the description.

In Table I-7 it can be seen how the threat responses to the interrogation codes are logically combined to establish which altitude threat bands the intruder occupies.

In the altitude separation evaluation sequence, the  $I_{+6}$  and  $I_{-6}$  interrogation codes are used to determine whether an intruder is equal altitude: if an intruder responds to the  $I_{+6}$  and  $I_{-6}$  interrogations then he is in the overlap region common to both the  $R_{+6}$  and  $R_{-6}$  response bands which extends from +50 ft. above to -50 ft. below the interrogator. The  $I_{+6}$  and  $I_{+13}$  interrogation codes are used to isolate the intruder as co-altitude above, 1300 ft. above, or 2000 ft. above. If an intruder responds to the  $I_{+6}$  but not the  $I_{+13}$  interrogation he is in the region of the  $R_{+6}$  response band which is exclusively  $R_{+6}$  which extends from -50 ft. to 650 ft. and therefore is a co-altitude target; if an intruder responds to the  $I_{+6}$  and the  $I_{+13}$  interrogations he is in the region common to the  $R_{+6}$  and  $R_{+13}$  response bands which extends from +650 ft. to 1350 ft. and, therefore, is a threat  $< 1300$  ft. above; if the intruder responds to the  $I_{+13}$  but not the  $I_{+6}$  interrogation he is in that region of the  $R_{+13}$  response band which is exclusively  $R_{+13}$  which extends from +1350 to +2050 and, therefore, is a threat  $< 2000$  ft. above. The  $I_{+13}$  and  $I_{+25}$  interrogation codes are used to isolate the intruder as a  $< 3200$  ft. above threat. If the intruder responds to the  $I_{+25}$  but not to the  $I_{+13}$ , he is in that region of the  $R_{+25}$  response band which is exclusively  $R_{+25}$  which extends from + 2050 ft. to + 3250 ft. and, therefore, is a threat  $< 3200$  ft. above.

The  $I_{+4}$  interrogation code is used to determine if an intruder is  $>400$  ft. co-altitude or  $<400$  ft. co altitude so that a determination can be made by the interrogating aircraft whether to bias its responses by -200 ft. in the direction of the dive maneuver. If the intruder responds to the  $I_{+4}$  interrogation, he is in the  $R_{+4}$  response band and is, therefore,  $<400$  ft. and requires bias; if the intruder does not respond to the  $I_{+4}$  interrogation, he is out of the  $R_{+4}$  response band and is, therefore,  $>400$  ft.

The  $I_{PCA}$  interrogation code is used to determine if an intruder is a predicted co-altitude above (PCA) threat. The  $I_{PCA}$  interrogation code has a variable bias which shifts up from a base value of -50 feet plus half the interrogators rate of ascent in feet per minute. For example, if the interrogators rate of ascent were 1000 fpm, the  $I_{PCA}$  bias would be shifted to + 450 ft. If the intruder responds to the  $I_{PCA}$  interrogation he is in the  $R_{PCA}$  response band which extends from - 250 ft. to + 1150 ft. and if he is also a  $<1300$  ft. threat, he is classified as a PCA threat.

TABLE I-7. ALTITUDE THREAT BAND LOGIC  
(ALTITUDE < 9600 FT)

INTERROGATION RESPONSES FROM THREATENING TARGETS	INTRUDER ALTITUDE SEPARATION (a) - FT	ALTITUDE THREAT BAND - FT
$R_{+25} \cdot \bar{I}_{+13} \cdot \bar{R}_{+6} \cdot \bar{R}_{-6} \cdot (h) > 1000 \text{ FPM}$	$+2000 < a \leq +3200$	$\leq 3200$ $I_{VS} < +2000 \text{ FPM}$
$R_{+13} \cdot \bar{R}_{+6} \cdot \bar{R}_{-6} \cdot (h) > 500 \text{ FPM}$	$+1300 < a \leq +2000$	$\leq 2000$ $I_{VS} < +1000 \text{ FPM}$
$R_{+6} \cdot \bar{I}_{+13} \cdot \bar{R}_{-6} \cdot \bar{I}_{+4}$ +	$+600 < a \leq +1300$	$\leq 1300$ $I_{VS} < +500 \text{ FPM}$
$R_{+13} \cdot \bar{I}_{+6} \cdot \bar{R}_{-6} \cdot (h) > 500 \text{ FPM}$		
$R_{+6} \cdot \bar{I}_{+13} \cdot [I_{PCA} + h > 2800 \text{ FPM}]$ +	$+600 < a \leq (+600$ $+0.5 \times \text{Rate of}$ $\text{Ascent In FPM})$	PCA (Predicted Co- Altitude)
$R_{+13} \cdot [I_{PCA} + h > 2800 \text{ FPM}] \cdot (h) > 500 \text{ FPM}$ +		Level Off
$R_{+25} \cdot [I_{PCA}] \cdot (h) > 1000 \text{ FPM}$		Do Not Turn
$R_{+6} \cdot \bar{I}_{+13} \cdot \bar{I}_{-6} \cdot \bar{I}_{+4}$	$+400 < a \leq +600$	Co-Altitude > +400 Climb Do Not Turn
$R_{+6} \cdot \bar{I}_{+13} \cdot \bar{I}_{-6} \cdot \bar{I}_{+4}$	$+50 < a \leq +400$	Co-Altitude $\leq$ +400 Climb Do Not Turn
$R_{+6} \cdot \bar{I}_{+13} \cdot \bar{I}_{-C} \cdot \bar{I}_{+4}$ +	$-50 \leq a \leq +50$	Equal Altitude Climb or Dive Do Not Turn
$R_{-6} \cdot \bar{I}_{-13} \cdot \bar{I}_{+6} \cdot \bar{I}_{-4}$		

TABLE I-7. ALTITUDE THREAT BAND LOGIC  
(ALTITUDE  $\leq$  9600 FT) (Cont.)

1.  $R_{+6}$  - THREAT RESPONSES IN ALL SUB EPOCHS, A THRU G, TO  $I_{+6}$  INTERROGATIONS.  
 $r_{+6}$  - THREAT RESPONSES IN SUB EPOCHS E AND G TO  $I_{+6}$  INTERROGATIONS.  
 $\bar{R}_{+6}$  - NO THREAT RESPONSE IN ONE SUB EPOCH A THRU G TO  $I_{+6}$  INTERROGATIONS.
2.  $(R) \geq 500$  FPM,  $\dot{h} > 1000$  FPM, - RATE OF ASCENT IN SUB EPOCH A.
3. ABOVE 9500 FT. ALTITUDE THE  $I_{+13}$  BIAS AND THE PCA BIAS IS INCREMENTED 200 FT.  
 ESTABLISHING CO-ALTITUDE AS 850 FT.
4. SIMILAR LOGIC FOR INTRUDERS BELOW INTERROGATING AIRCRAFT.

Figure I-5 depicts the interrogation sequence which is followed for altitude threat band evaluation. Table I-5 is an interrogation decision logic table which delineates the start conditions for each of the basic altitude bands I<sub>+6</sub>, I<sub>-6</sub>, I<sub>+13</sub>, I<sub>-13</sub>, I<sub>+25</sub> and I<sub>-25</sub> and, the branch conditions for all of the bands including the auxiliary bands I<sub>+4</sub>, I<sub>-4</sub>, I<sub>PCA</sub> and I<sub>PCB</sub>. In Figure I-5 and Table I-5 it will be noted that a complete horizontal line of interrogations in every sub-epoch A through G in any basic altitude band represents a TAU track leading to a TAU 2 or TAU 1 threat evaluation together with the proper command. The branch interrogations in sub-epochs E and G are only for purposes of altitude threat band isolation; the logic demands that a response be present in both sub-epochs E and G for the intruder to be considered as being in the branch response band. The branching from the I<sub>+6</sub> to the I<sub>-6</sub> and the reverse is to detect an intruder which is oscillating above and below the equal altitude boundary and thus assist in the bias logic decision on whether to bias up or down to insure complementary maneuvers.

Table I-7 shows how the threat responses to the interrogation codes are logically combined to establish which altitude threat band the intruder occupies. In Figure I-5, and Table I-5, it can be seen that the two outermost basic altitude bands I<sub>+25</sub> and I<sub>+13</sub> and, the I<sub>-25</sub> and I<sub>-13</sub> are only interrogated in a horizontal line once every 6.5 seconds. This results in the following threat epoch times:

3.2 second epoch - All TAU 1 threats; all TAU 2 threats and

PCA, PCB threats <1300 ft.

6.5 second epoch - All TAU 2 threats and PCA or PCB

threats ≥1300 ft.

In Table I-7, it will also be seen that if own aircraft is in level flight, an assessment of the presence or absence of aircraft >1300 ft. above own aircraft is not made. If own aircraft rate of ascent is > + 500 fpm an assessment is made of aircraft >1300 ft. but ≤2000 ft.; if rate of ascent is >1000 fpm then an assessment is made of aircraft up to + 3200 ft. To prevent loss of a data track during a period when the aircraft may oscillate between an ascent rate above and below the ascent rate boundary, the logic is latched in sub-epoch A for all subsequent sub-epochs through G. The same logic is used when descending at rates greater than 500 fpm and 1000 fpm.

#### TYPICAL SEQUENCE

Referring to Figure I-5 and Tables I-5 and I-7 we follow an intruder through the decision logic. Assume own aircraft flying level, with intruder aircraft 300 ft. above own aircraft with a range and closing rate meeting the conditions for a TAU 2 threat. The sequence commences with two sets of I<sub>+6</sub> interrogations in sub-epoch A, followed 2 milliseconds later by two sets of I<sub>-6</sub>

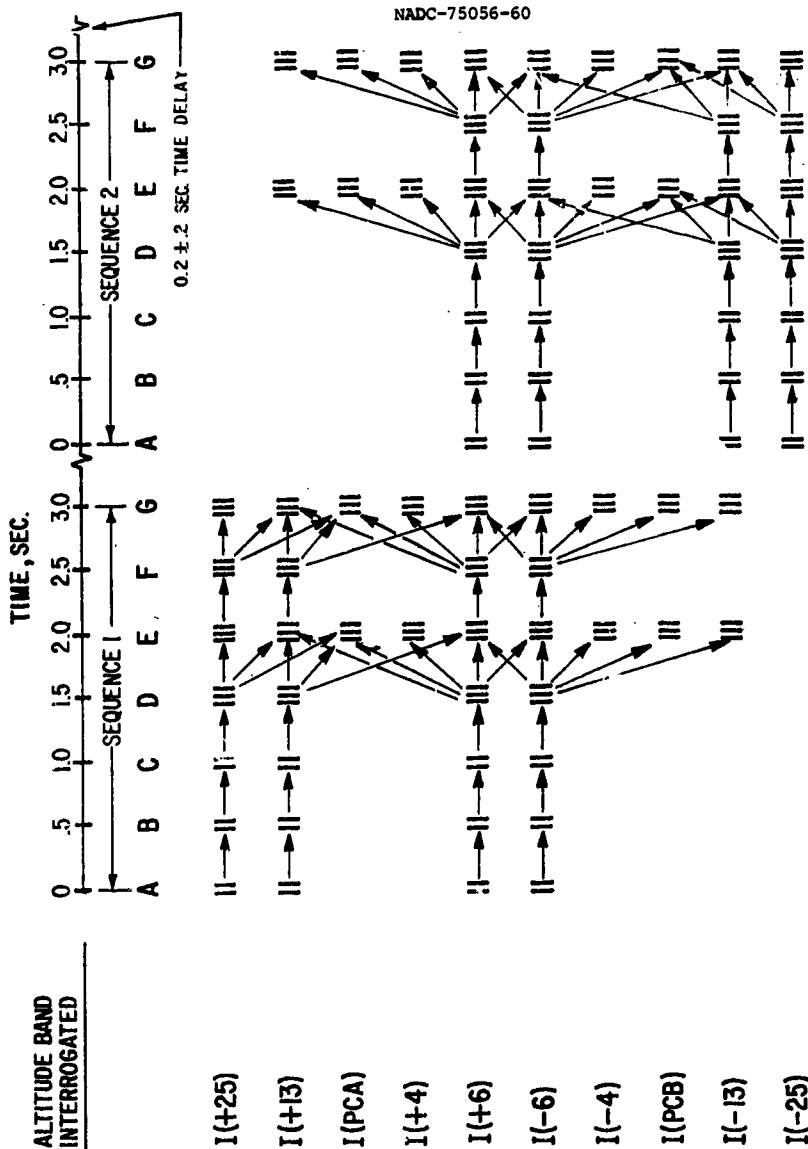

Figure I-5. Interrogation Sequence.

interrogations. If at least one reply is received to the two  $I_{+6}$  interrogations in sub-epoch A, a second set of two  $I_{+6}$  interrogations is transmitted in sub-epoch B; if at least one reply is received which meets the TAU filter threat criteria for the number of bins skipped relative to the initial range bin location of the intruder in sub-epoch A, the target is classified as a  $T_{+6}$  threat for sub-epoch B. (Since the intruder is 300 ft. above own aircraft a response to the  $I_{-6}$  interrogation will not be received. However there is a finite probability that a response to another aircraft's interrogation may be received in the  $I_{-6}$  band; this would then be rejected in subsequent sub-epochs when the TAU criteria was applied.) This enables the interrogation logic to proceed with two  $I_{+6}$  interrogations in sub-epoch C; if a reply is received which meets the TAU filter criteria the target is a  $T_{+6}$  threat for sub-epoch C. This enables the interrogation logic to proceed with three  $I_{+6}$  interrogations in sub-epoch D; if a reply is received which meets the TAU filter threat criteria, the target is a  $T_{+6}$  threat for sub-epoch D. This enables the interrogation logic to proceed with three  $I_{+6}$ , three  $I_{+4}$  and three  $I_{-6}$  interrogations in sub-epoch E in order to determine if the target is a  $T_{+6}$  threat and to isolate the target to one of the altitude threat bands between 0 and 1300 ft. above the interrogating aircraft. If no replies are received to the  $I_{+13}$  or the  $I_{-6}$  interrogations but are received to the  $I_{+6}$  and  $I_{+4}$  interrogations and the  $I_{+6}$  reply meets the TAU filter criteria, the target is a  $T_{+6}$  threat in sub-epoch E with a vertical separation above own aircraft between 100 and 400 ft. The  $T_{+6}$  threat in sub-epoch E enables the interrogation logic to proceed with three  $I_{+6}$  interrogations in sub-epoch F; if at least one reply is received which meets the TAU filter threat criteria the target is a  $T_{+6}$  threat for sub-epoch F. This enables the interrogation logic to proceed with three  $I_{+6}$ , three  $I_{+13}$ , three  $I_{+4}$  and three  $I_{-6}$  interrogations in sub-epoch G. If no replies are received to the  $I_{+13}$  or the  $I_{-6}$  interrogations but are received to the  $I_{+6}$  and  $I_{+4}$  interrogations and the  $I_{+6}$  reply meets the TAU filter threat criteria, the target is a  $T_{+6}$  threat in sub-epoch G with a vertical separation from own aircraft between 100 ft. and 400 ft. Only  $I_{+13}$ ,  $I_{+4}$  or  $I_{-6}$  interrogations are received in both sub-epochs E and G is the intruder considered as occupying the associated band. Since this criteria was met, the target is handed off to the final logic as a TAU 2 threat with vertical separation between 100 ft. and 400 ft.

It will be noted that the logic demands only one reply to two interrogations in sub-epochs A, B and C and only one reply to the three interrogations in sub-epochs D, E, F and G. Two interrogations separated by 3 milliseconds are made in sub-epochs A, B and C to insure a high probability of detection of the target. If replies are received in sub-epochs A, B and C thus establishing a data track, the number of interrogations are increased to three to insure an extremely high probability of completing the data track covering all seven sub-epochs. It will also be noted in the logic table that the  $(T_{+13})$  entry in  $I_{+13}$  block under set F means that the interrogation logic for the  $I_{+13}$  band sub-epoch F is only enabled if a  $T_{+13}$  threat existed in sub-epoch A through E; it does not mean that the interrogation logic is enabled if a response is received only in sub-epoch E which is used only for altitude band discrimination and not for a TAU track.

#### HARDWARE CONFIGURATION

The AVOID I tested was an engineering prototype packaged in a 1/2 short ATR equipment case which approaches the 3/8 short ATR production configuration. An outline drawing with dimensions is shown in Figure I-6. In Figure I-7 the AVOID I is shown with the dust cover removed. Ambient air is drawn through a series of large holes in the rear of the unit across the digital processor cards (which are mounted parallel to the air stream) and exhausted through the front panel. The method was extremely effective in removing the heat from the densely packed unit which weighed 18.5 pounds.

Figure I-8 is a photograph of the AVOID I together with the CAS/VSI indicator. Figure I-9. is a close-up of the CAS/VSI indicator in the test mode in which all command lights are illuminated.

NADC-75056-60

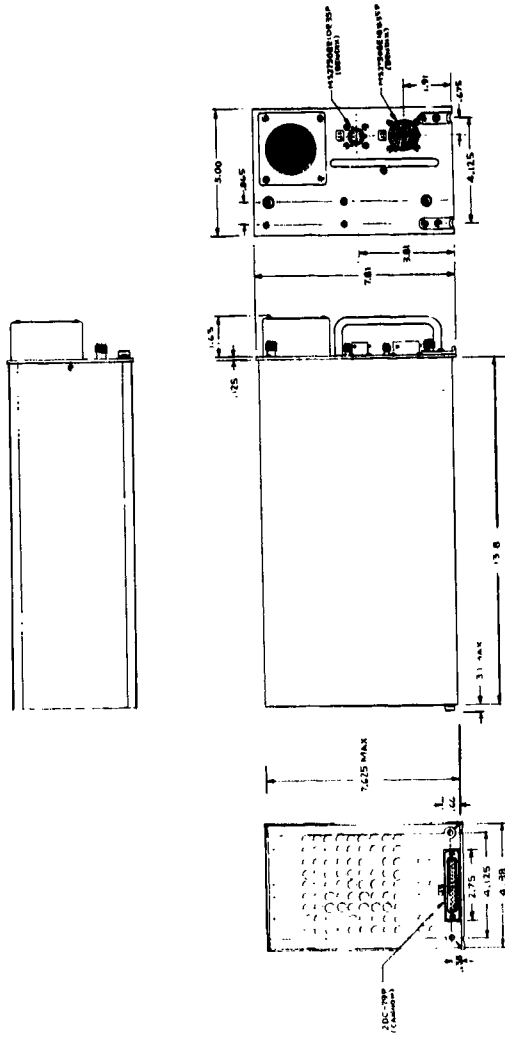

Figure I-6. AVOID I Outline Drawing.

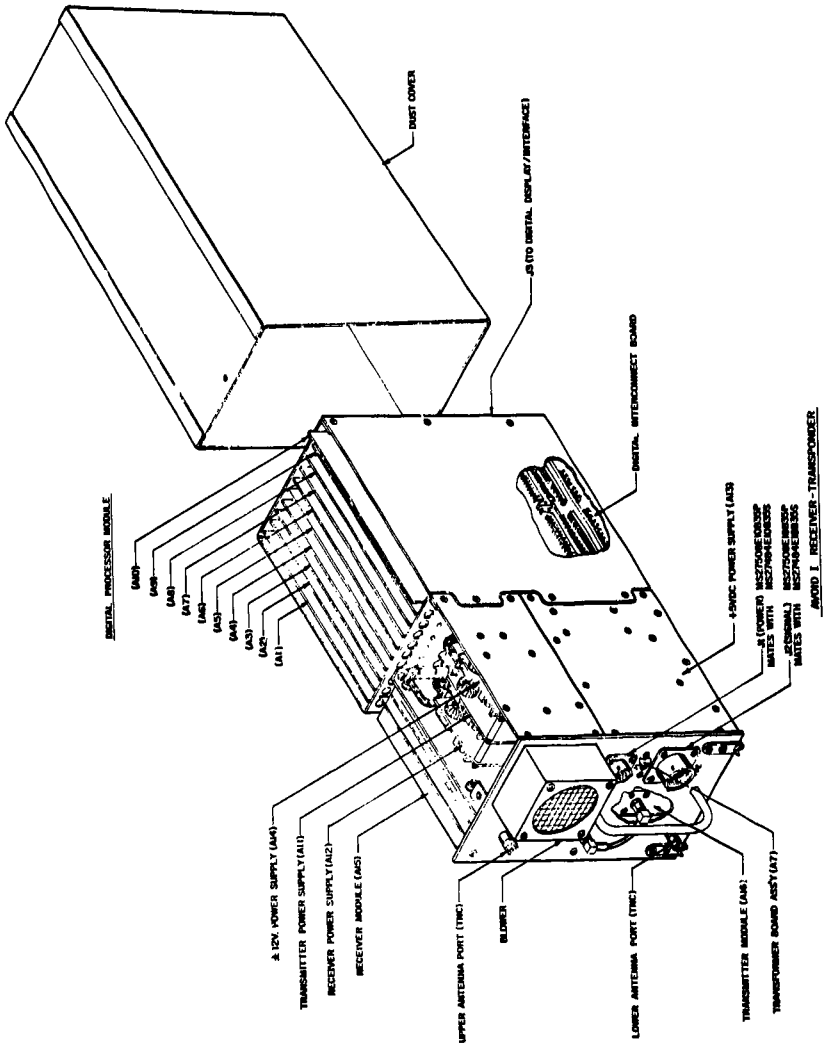

Figure I-7. AVOID 1 - With Cover Removed



Figure I-8. AVOID I Complete With CAS/VSI Indicator.

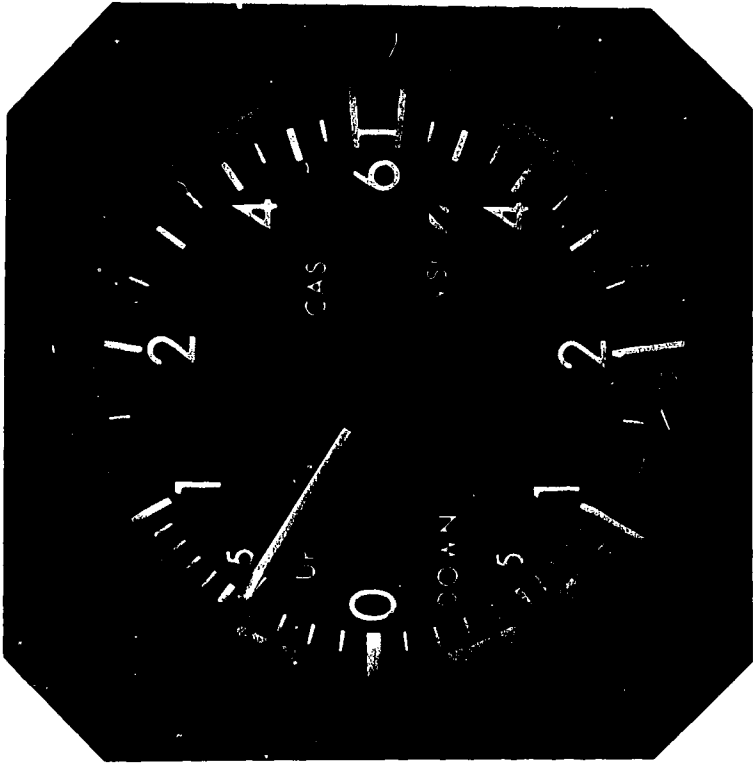

Figure I-9. CAS/VSI Indicator in Test Mode.

CHAPTER II

AIRCRAFT INSTALLATION AND FLIGHT TEST INSTRUMENTATION

AIRCRAFT INSTALLATION

The three NAVAIRDEVGEN aircraft provided for this flight test evaluation were the NC-117 (BuNo 12431), the P-3A (BuNo 148883), and the RA-3B (BuNo 144833). The maximum airspeed capabilities were as follows:

NC-117 - 160 knots  
P-3A - 300 knots  
RA-3B - 550 knots

The P-3A and RA-3B installations consisted of the following equipment complement:

1. AVOID I with two CAS/VSI indicators
2. Digital Display and Interface (DDI)
3. Traffic Simulator, Calibration Generator (TS)
4. Kennedy Model 1708 Digital Tape Recorder
5. AN/ARN-84 Airborne TACAN Set
6. Precision Clock System Consisting of:
  - a. General Radio 1115-C Standard Frequency Oscillator
  - b. General Radio 1123-A Digital Synchrometer
  - c. General Radio 1124 WWV Receiver with Synchronizing Oscilloscope
7. Intercontinental Dynamics Corporation Type 518-16007-V212 Digitally Encoded Barometric Altimeter

The NC-117 installation had the same basic complement, but had additional racks to accommodate an additional digital display and interface, and traffic simulator. A photo theater was also provided which contained an attitude indicator; an airspeed indicator; a TACAN bearing, distance, and heading indicator; a parallel storage unit to transfer time from the master clock aboard the aircraft; the DDI;

and a Photosonics Model 1P pulsed camera. At the end of each round, simultaneous strobe pulses transferred time from the master clock to the parallel storage unit and pulsed the camera. Thus, a permanent record of the flight parameters and DDI read-outs was obtained; the latter serving as a back-up if the magnetic recording system or multiplexer malfunctioned.

The antenna locations and cable lengths are listed in Table II-1. Outline drawings of each aircraft, showing the locations of the upper and lower CAS antenna, are provided in Figures II-1, II-2, and II-3.

TABLE II-1. ANTENNA LOCATIONS

Aircraft	Lower Antenna			Upper Antenna		
	Station (inches)	Centerline Offset (inches)	Lead-in lengths (feet)	Station (inches)	Centerline Offset (inches)	Lead-in lengths (feet)
RA-3B	175	19 port	13	283	0	3
NC-117	22	0	50	51	0	40
F-3A	383	10 port	21	350	0	11

## TRAFFIC SIMULATOR

The purpose of the Traffic Simulator, Figure II-4, was threefold:

1. To serve as a calibration unit to insure that the AVOID I's were working properly at all times
2. To serve as a source of uncorrelated replies (fruit) and interrogations equivalent to that anticipated in the Los Angeles Terminal Area in 1982.
3. To serve as a source of threatening and non-threatening targets for laboratory tests.

By using the Traffic Simulator in conjunction with the Digital Display and Interface, by setting the attenuator above minimum receiver signal level, and by injecting an altitude signal appropriate to the desired altitude required, the accuracy of the desired altitude boundaries of 600 ft, 1300 ft, 2000 ft

NADC-75056-60

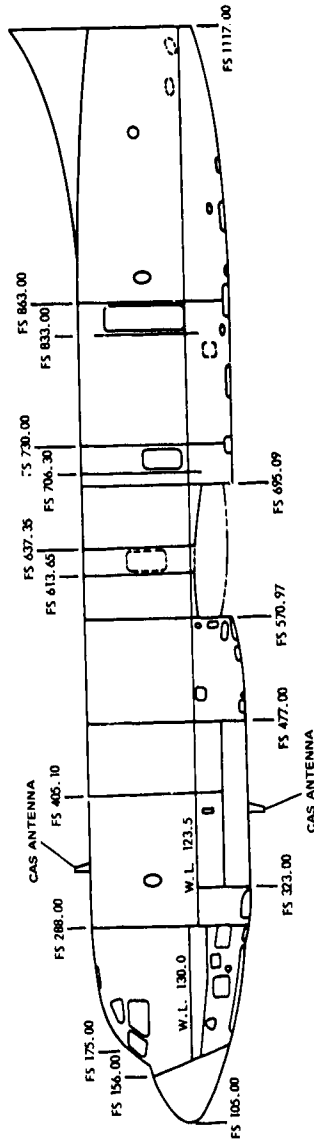

Figure II-1. CAS Antenna Locations of P-3A

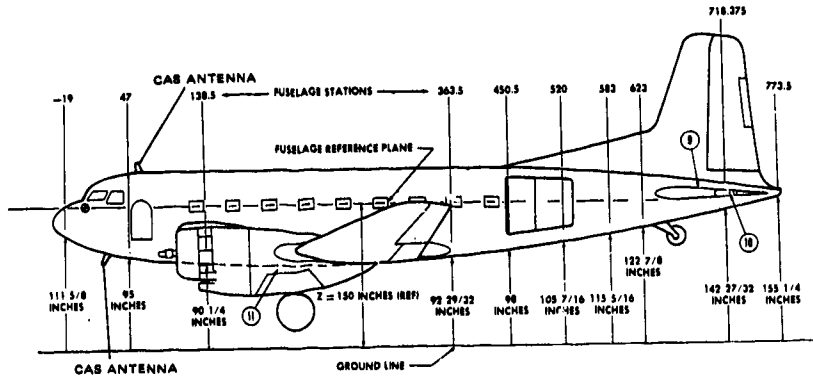

Figure II-2. CAS Antenna Locations NC-117

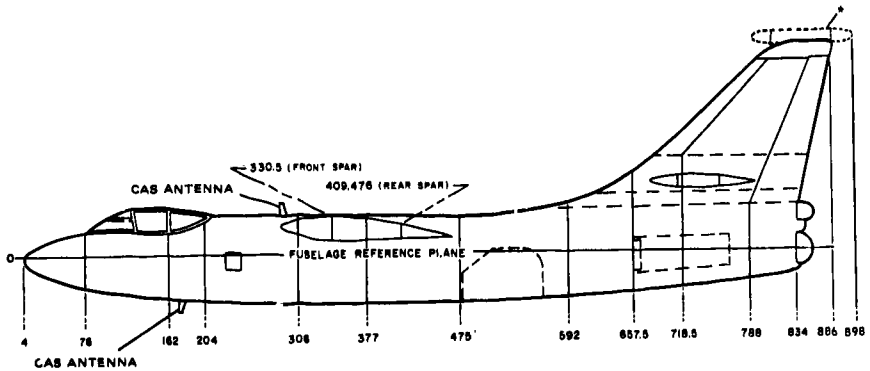

Figure II-3. CAS Antenna Locations RA-3B

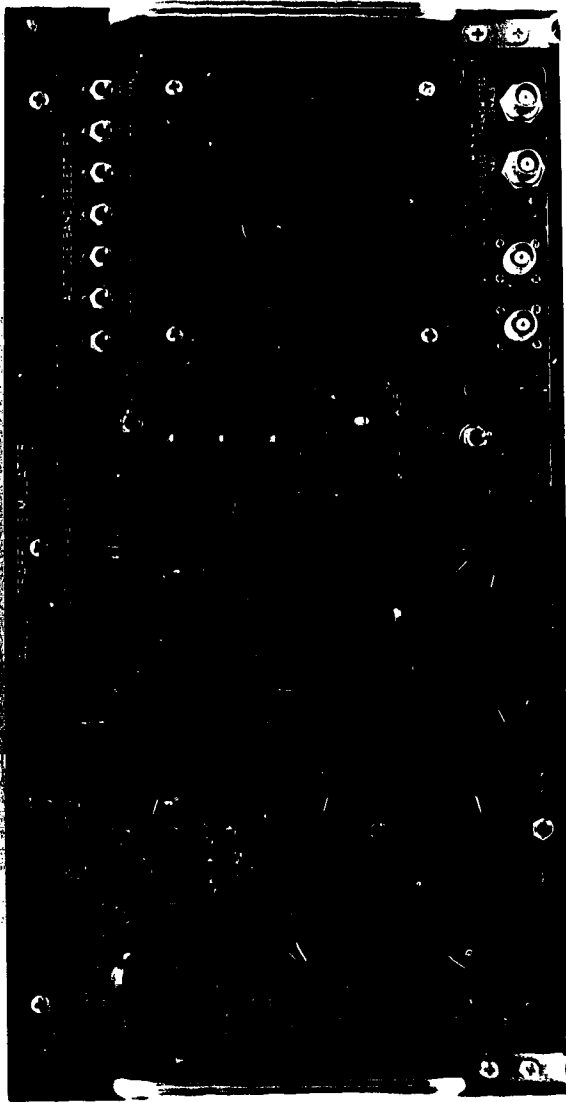

Figure II-4. Traffic Simulator Front Panel

and 3200 ft can be checked. The targets can be placed at the boundaries with the altitude band select switches and the altitude bias switch. If it is desired to place a target 600 ft above own aircraft, the altitude band select switch would be set to +900 ft, the altitude bias switch set to -300 ft, and a fixed range set in at less than the TAU ONE threshold (1600 ft or less on the traffic simulator). To simulate vertical rates, an auxiliary unit was used to inject signals equivalent to vertical rates from 0 to 6000 fpm. By sequencing the altitude switches and vertical rate control in the manner indicated, the commands listed in Table II-2 were displayed. This routine checks out all of the fixed altitude threat bands as well as the variable predicted coalatitude band; the boundary which moves out from a base of 800 ft (for the above 9500 ft altitude required) plus one half the vertical rate in feet per minute. Thus for a vertical rate of 1600 fpm, the predicted coalatitude band would extend to 1600 ft altitude differential and any intruder which penetrates that boundary would be considered a predicted coalatitude threat which would output a level off command to the display. To check out the three aircraft threat logic, much the same procedure is followed with the exception that two traffic simulators must be used, each with a separate altitude input. The above/above portion of the three aircraft matrix is exercised by placing the two traffic simulator altitudes at appropriate values above own aircraft. The above/below matrix is checked similarly by placing one traffic simulator altitude above own aircraft and the other below own aircraft.

In order to insure that the AVOID I processor is working throughout its maximum range and is measuring closing rate properly, an altitude signal corresponding to 10,000 ft is set into the AVOID, Traffic Simulator, and Digital Display and Interface; a target is set in at 102,400 ft (17 nmi) with a closing rate of 1600 ft/sec (948 knots). Placing the hold switch in the off position and pressing the initiate button, the target begins to move. Every three seconds, the closing rate of 1600 ft/sec is displayed on the Digital Display together with the range to the intruder at the end of the three second round, as well as TAU (range divided by range rate). When the TAU TWO threshold of approximately 47 seconds is exceeded at 12.3 nmi, the TAU TWO light will come on and when the TAU ONE threshold of approximately 26 seconds is exceeded at 6.8 nmi, the TAU ONE light will come on. Concurrent with these events, the VSI/CAS display will yield the appropriate commands, and all of the data will be recorded on tape for computer processing and analysis impossible to perform from visual observation of the Digital Display.

It will be noted that three sets of targets can be generated with 33 targets in each set. The closing rate selected for each set applies to all targets in the set. The spacing between targets within a set is determined by the number of targets selected and the maximum range selected. Each set can be placed in an opening rate or closing rate mode so that the effects of the interaction of non-threatening targets with the threatening targets can be observed as well as the effects of fast moving targets overtaking slower moving targets. The traffic simulator did lack the flexibility to place each target set at a differ-

Table II-2. ALTITUDE THREAT BOUNDARY  
CHECK-OUT PROCEDURES FOR ALTITUDE REGIME  
ABOVE 9500 FEET

ALTITUDE BAND SELECT-FT	ALTITUDE BIAS FT	TARGET RANGE FT	VERTICAL RATE FPM	DISPLAY
+3000	+400	1600	1100 Up	None
+3000	+200	"	1100 Up	LVS 2000 FPM Up
+1800	+400	"	600 Up	LVS 1000 FPM Up
+1800	-400	"	600 Up	LVS 1000 FPM Up
+900	+400	"	0	LVS 500 FPM Up
+900	-100	"	0	Dive
+900	-400	"	0	Dive
0	+400	"	0	Dive (Bias)
0	0	"	0	Dive or Climb (Bias)
0	-400	"	0	Climb (Bias)
-900	+400	"	0	Climb
-900	+100	"	0	Climb
-900	-400	"	0	LVS 500 FPM Down
-1800	+400	"	600 Down	LVS 1000 FPM Down
-1800	-400	"	600 Down	LVS 1000 FPM Down
-3000	-200	"	1100 Down	LVS 2000 FPM Down
-3000	-400	"	1100 Down	None
+1800	+200	"	2000 Up	LVS 1000 FPM Up
+1800	0	"	2000 Up	Level Off
+1800	-400	"	1000 Up	LVS 1000 FPM Up
+900	+400	"	1000 Up	Level Off
+900	+300	"	500 Up	LVS 500 FPM Up
+900	+100	"	500 Up	Level Off*

\*The lower predicted coalitude bands are then checked

ent altitude. In order to accomplish this, additional traffic simulators had to be used.

A very important function of the traffic simulator was to supply fruit and interrogations to the AVOID I during laboratory and flight tests. A pseudo-random noise generator provided fruit pulses with a repeat cycle of 9.3 hours at the maximum fruit rate. Fruit could be generated at rates from 1000 to 64,000 pps. Interrogations were also generated at rates from 6 to 1536 interrogation quads/second. A mode switch permitted either 20% or 100% of the interrogations to be within the altitude acceptance gate of the AVOID I being interrogated. In the 20% position, 80% of the interrogations were outside of the target's altitude response band. The predicted fruit rate in Appendix A of the FAA 1982 Los Angeles Traffic Model of 32K/1536 (20%) was used for a large number of tests. Twice this rate, 64K/1536 (20%) recommended in Appendix A was used in many of the tests to determine degradation factors. In still other tests, particularly false alarm tests, the fruit level was taken up to 96K/3072 (20%) using two traffic simulators to accelerate tests too lengthy to run at lower fruit rates.

#### DIGITAL DISPLAY AND INTERFACE (DDI)

Before Honeywell's proposal submission, NAVAIRDEVCON initiated several lengthy technical sessions with Honeywell in which NAVAIRDEVCON delineated the parameters to be displayed on the digital display and those to be interfaced with the NAVAIRDEVCON incremental magnetic tape recorder installed in each aircraft to gather data from the AVOID I CAS during actual in-flight collision encounters. NAVAIRDEVCON not only indicated which output parameters were to be recorded, but also those internal parameters which were considered crucial to an incontestable evaluation. In reviewing the system operation, NAVAIRDEVCON determined that the normal operating mode of the equipment was such that unreasonable amounts of money and flight time would be required to determine the communications reliability and range rate accuracy of the AVOID I. This comes about because the AVOID I only completes an interrogation sequence if a TAU ONE or TAU TWO threat exists. Thus, if two aircraft are flying a collision encounter and are not a threat to each other, no range or range rate measurement is possible until the range divided by range rate has exceeded the appropriate TAU threshold. This led to the concept of a special interrogation mode for gathering range and range rate data before entering the TAU TWO threat zone. This mode was called the unrestricted mode. In this mode, a complete set of interrogations was made every 3.2 seconds regardless of whether an intruder was present or not. In this way range, range rate and TAU data was available outside of the TAU threat zones and meaningful statistics could be compiled for communications reliability, communications range, and range/range rate accuracies irrespective of the maximum aircraft speeds available. Thus, in most of the flights, the equipment was placed initially in the unrestricted mode to gather communications reliability data prior to entry into the TAU TWO zone. When the

TAU TWO threshold was exceeded, the mode was changed to normal for subsequent data in that encounter until a point was reached at which the aircraft had an opening rate. Then, the unrestricted mode was enabled to gather opening data.

As can be seen on the front panel of the engineering display in Figure II-5, the following parameters were displayed for real time observation:

1. TAU in seconds to the nearest second up to a maximum of 89 seconds (90 seconds signifies  $\geq 90$  seconds and 99 seconds signifies an opening rate)
2. Range in thousands of feet to the nearest 100 ft to a maximum of 999.9 kilofeet (164.6 nmi)
3. Range rate in feet per second to the nearest 10 feet per second (6 knots) (Even though the digital read-out is to the nearest foot per second, the smallest increment possible is 10 feet per second)
4. Interrogations transmitted in interrogation quads per second to the nearest quad per second
5. Interrogations received from the traffic simulator in quads per second to the nearest quad per second up to a maximum of 9999 quads per second
6. Fruit replies received from the traffic simulator in 100's of replies per second to the nearest 100 replies per second up to a maximum of 99,900 replies per second on the display (Actually at fruit rates beyond this, the counter is still operative, e.g., 128,000 pulses per second will appear as 28,000 pulses per second)
7. Intruder 1 and intruder 2 threat levels of TAU ONE, TAU TWO, TAU EQUAL predicted coaltitude,  $\leq 1300$  ft,  $\leq 1800$  ft, and  $\leq 3300$  ft altitude differentials for targets above and/or below together with an indication of whether bias has been applied to responses are displayed by small indicator lights alongside the appropriate threat legend.
8. Intruder 1/Intruder 2 switch selects which intruder's range, range rate and TAU are displayed.
9. Start sequence switch - permits transfer of data from the DDI to the incremental tape recorder.
10. Month/day switches set date which is interfaced and recorded on tape recorder.
11. Flight/encounter switches set flight number and encounter number which is interfaced and recorded on tape recorder.

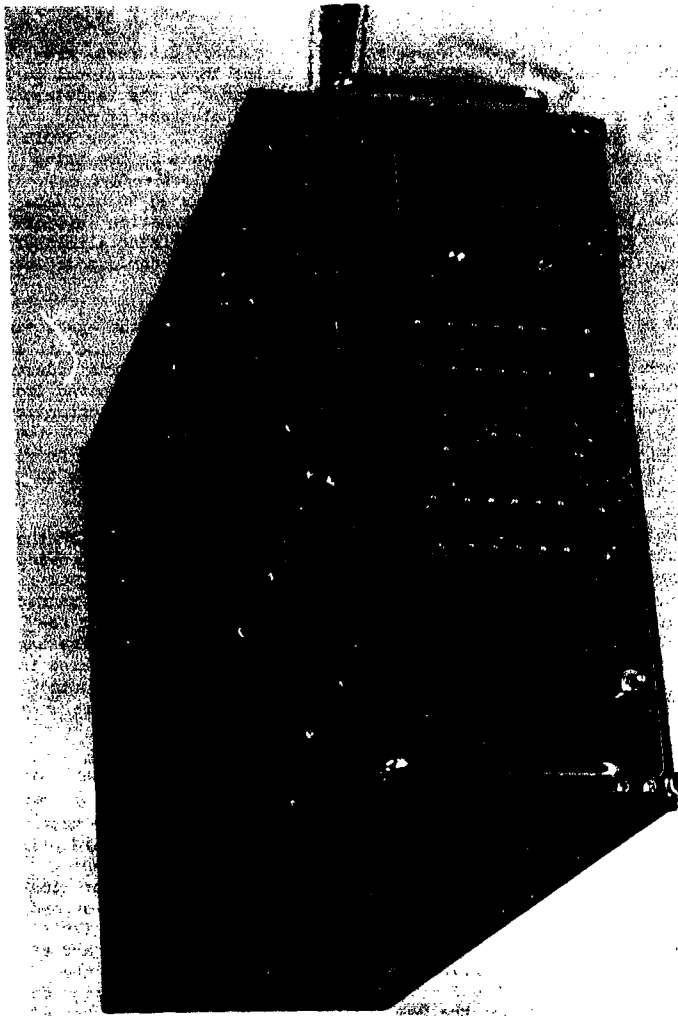

Figure II-5. Engineering Display/digital Interface - Front Panel

Figure II-6 and Figure II-7 are block and system interconnect diagrams, respectively, of the DDI and system interfaces. They depict those additional parameters (over and above those displayed) which are interfaced to the recorder. These include TACAN range and bearing, real time, digital altitude of own aircraft, range, range rate, and TAU to both intruders 1 and 2, and the AVOID internal threat status of all threats on a round-to-round basis before being processed through the display logic. By means of control pulses referenced to 100 KHz clock pulses generated by the DDI, the DDI transferred 20 bit data messages from the TACAN which contained range and bearing information (approximately 300 ft accuracy in range and 2° in bearing). The digitizing altimeter provided altitude in grey code which was interfaced to the recorder and decoded from the tape by the computer program.

The digital clock system installed in each aircraft provided the exact time at the end of each round with a read-out to a 0.1 millisecond. The clock in each aircraft was synchronized to WWV by aligning the eight millisecond wide pedestal from the synchronometer with the eight millisecond wide time tick received from WWV once every second. With all aircraft and the theodolite range synchronized in this manner to within approximately a millisecond, data at both ends of the link could be compared to a common time reference and this in turn could be compared to the theodolite measurement of aircraft range and closing rate to assess the accuracy of the AVOID in measuring those parameters.

The DDI processed all of the digital data for proper interfacing with the Kennedy Model 1708 seven track incremental magnetic tape recorder. It provided 80 characters consisting of four bit bytes; an 80 to 1 multiplexer was used to convert the parallel data input to a serial data output required by the Kennedy 1708. An odd parity check was generated internally in the tape unit and recorded on the seventh tape track. To insure accurately recorded data, the tape deck had a buffer memory in which all incoming data was stored and compared to the recorded data. If the two were not exact, the data was rerecorded automatically. The tape format is shown in Figure II-8

#### COMPUTER PRINT-OUT OF IN-FLIGHT DATA

After each flight, the tape from each aircraft was taken to the NAVAIRDEVCON CDC 6600 Digital Computer for decoding and print-out. Since all of the data recorded during a round would not fit within the confines of the standard print-out, the data as referenced to time had to be split up into two different print-outs. The first section of the print-out (Section 1) consisted of time; the CAS display command; the range in kilofeet, range rate in feet per second, and TAU and threat levels for intruder 1 and intruder 2; own altitude; fruit replies received; interrogations transmitted; interrogations received; and all threats data. A sample Section 1 print-out comprises Figure II-9, and the nomenclature will be found in Table II-3. The second section of the print-out (Section 2) consisted of the time; the CAS display command; the range, range rate

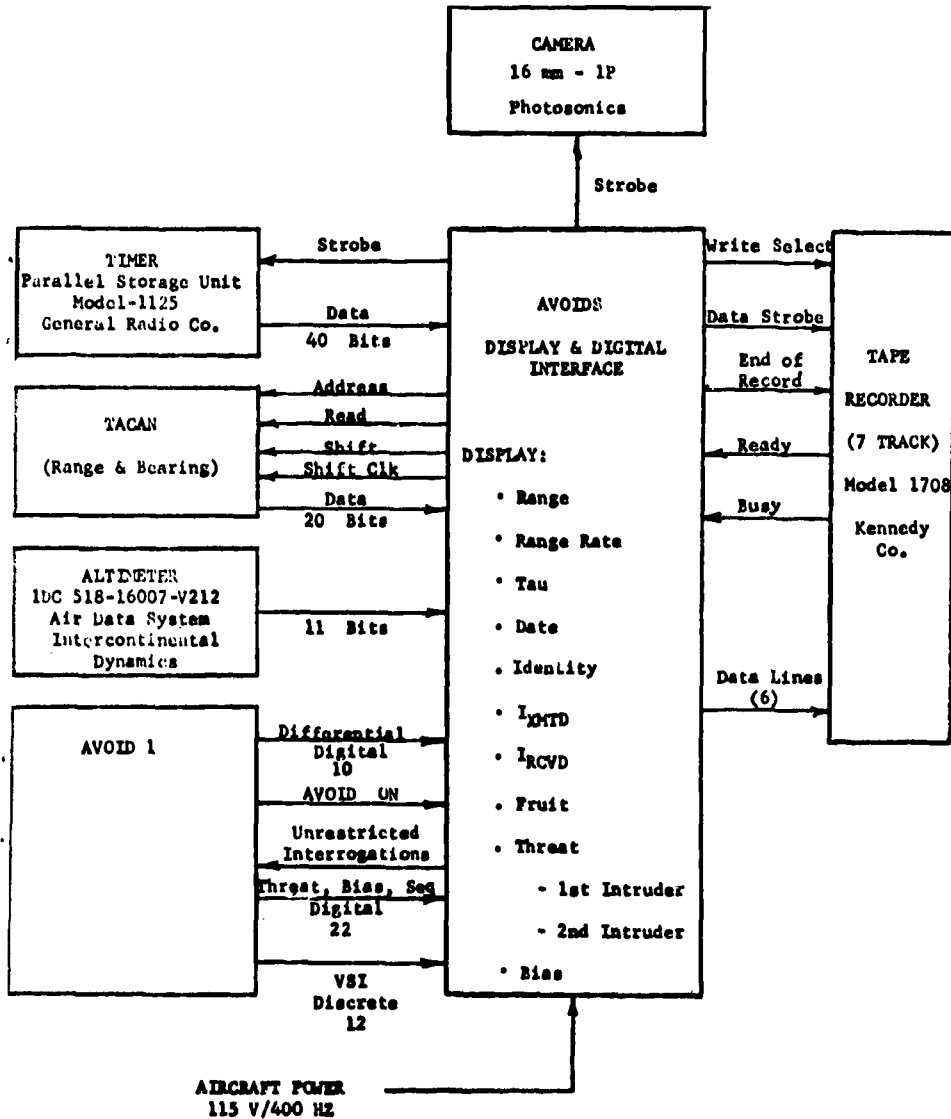

Figure II-6. Block Diagram of DDI and System Interfaces.

Reproduced from  
best available copy.

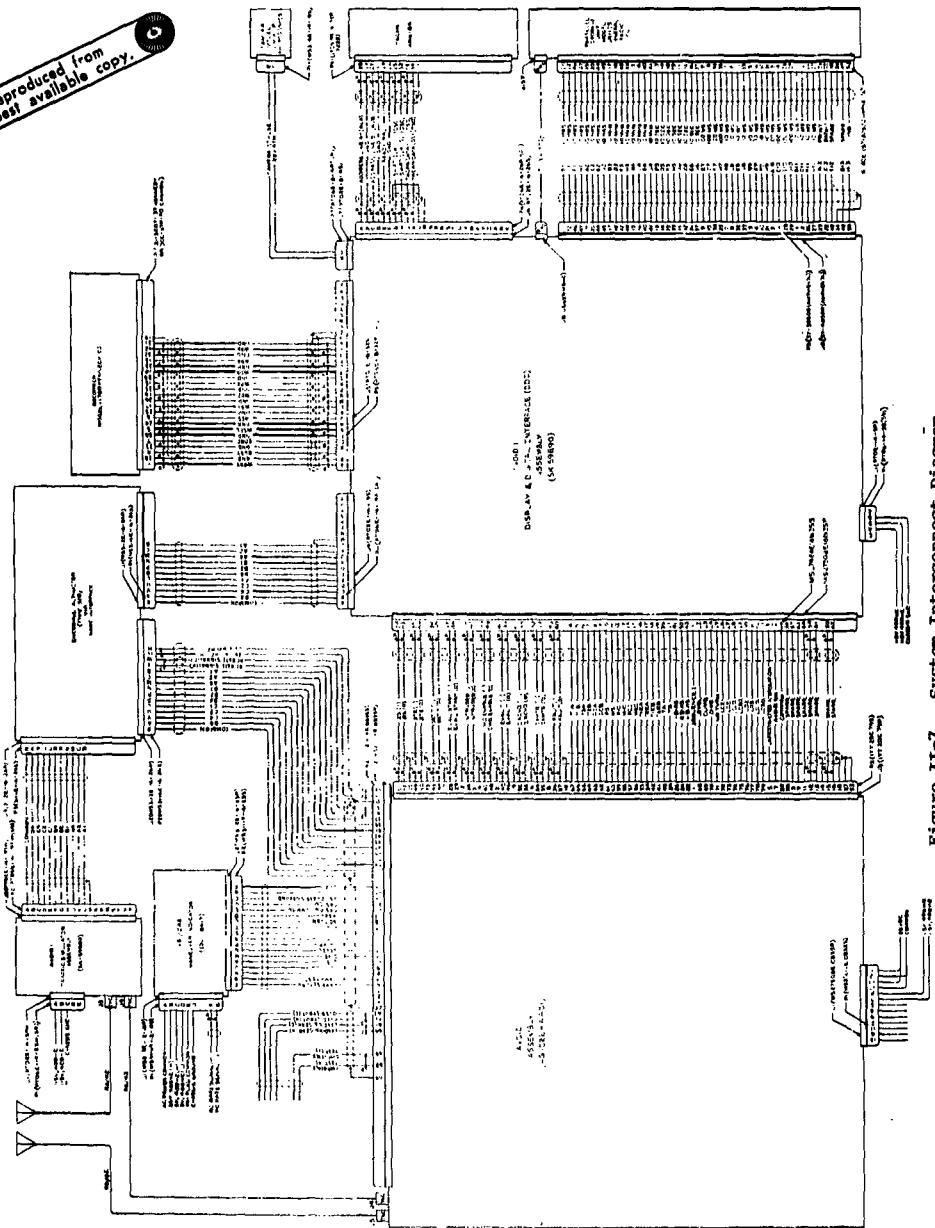

Figure II-7. System Interconnect Diagram.

FUNCTION	MUX IC	CHAR	MUX PEN #	MUX ASSY #					OCTAVE	CODE	COMMENT
				1	2	3	4	5			
				8	A	B	C	D			
DATE FILE NO DAY MO	Tens Units	1	30	X	X	X	X	X	1	BCD	All data provided on 6 tracks 8, 4, 2, 1
		2	3	X	X	X	X	X			
TIME MIN HR	Tens Units	3	29	X	X	X	X	X	2	BCD Binary BCD	Parity provided on track 8
		4	4	X	X	X	X	X			
RANGE 1ST INTRUDER	Tens Units	5	3	X	X	X	X	X	3	BCD Binary BCD	Char 21 Bit 0 Display Bit "1" Display 1 "0" Display 2 Bit 1 Sign Bit "1" Positive "0" Negative Same for Char 31
		6	28	X	X	X	X	X			
RANGE 2ND INTRUDER	Tens Units	7	61	X	X	X	X	X	4	BCD Binary BCD	Char 60 Bit 0 Bias + Bit 4 Bias 0 Bit 2 Bias - Bit 1 Sequence Bit "1" SEQ 1 "0" SEQ 2
		8	23	X	X	X	X	X			
RANGE 3RD INTRUDER	Tens Units	9	95	X	X	X	X	X	5	Binary	Char 73 Bit 2 Intruder 1 Y8 Bit 1 Intruder 2 Y8
		10	68	X	X	X	X	X			
RANGE 4TH INTRUDER	Tens Units	11	67	X	X	X	X	X	6	Binary	Char 73 Bit 2 Intruder 1 Y8 Bit 1 Intruder 2 Y8
		12	66	X	X	X	X	X			
RANGE 5TH INTRUDER	Tens Units	13	69	X	X	X	X	X	7	Binary	Char 73 Bit 2 Intruder 1 Y8 Bit 1 Intruder 2 Y8
		14	70	X	X	X	X	X			
RANGE 6TH INTRUDER	Tens Units	15	63	X	X	X	X	X	8	Binary	Char 73 Bit 2 Intruder 1 Y8 Bit 1 Intruder 2 Y8
		16	62	X	X	X	X	X			
RANGE 7TH INTRUDER	Tens Units	17	11	X	X	X	X	X	9	Binary	Char 73 Bit 2 Intruder 1 Y8 Bit 1 Intruder 2 Y8
		18	10	X	X	X	X	X			
RANGE 8TH INTRUDER	Tens Units	19	9	X	X	X	X	X	10	Binary	Char 73 Bit 2 Intruder 1 Y8 Bit 1 Intruder 2 Y8
		20	8	X	X	X	X	X			
RANGE 9TH INTRUDER	Tens Units	21	34	X	X	X	X	X	11	Binary	Char 73 Bit 2 Intruder 1 Y8 Bit 1 Intruder 2 Y8
		22	33	X	X	X	X	X			
RANGE 10TH INTRUDER	Tens Units	23	36	X	X	X	X	X	12	Binary	Char 73 Bit 2 Intruder 1 Y8 Bit 1 Intruder 2 Y8
		24	37	X	X	X	X	X			
RANGE 11TH INTRUDER	Tens Units	25	20	X	X	X	X	X	13	Binary	Char 73 Bit 2 Intruder 1 Y8 Bit 1 Intruder 2 Y8
		26	19	X	X	X	X	X			
RANGE 12TH INTRUDER	Tens Units	27	17	X	X	X	X	X	14	Binary	Char 73 Bit 2 Intruder 1 Y8 Bit 1 Intruder 2 Y8
		28	41	X	X	X	X	X			
RANGE 13TH INTRUDER	Tens Units	29	42	X	X	X	X	X	15	Binary	Char 73 Bit 2 Intruder 1 Y8 Bit 1 Intruder 2 Y8
		30	43	X	X	X	X	X			
RANGE 14TH INTRUDER	Tens Units	31	44	X	X	X	X	X	16	Binary	Char 73 Bit 2 Intruder 1 Y8 Bit 1 Intruder 2 Y8
		32	45	X	X	X	X	X			
RANGE 15TH INTRUDER	Tens Units	33	79	X	X	X	X	X	17	Binary	Char 73 Bit 2 Intruder 1 Y8 Bit 1 Intruder 2 Y8
		34	84	X	X	X	X	X			
RANGE 16TH INTRUDER	Tens Units	35	53	X	X	X	X	X	18	Binary	Char 73 Bit 2 Intruder 1 Y8 Bit 1 Intruder 2 Y8
		36	52	X	X	X	X	X			
RANGE 17TH INTRUDER	Tens Units	37	51	X	X	X	X	X	19	Binary	Char 73 Bit 2 Intruder 1 Y8 Bit 1 Intruder 2 Y8
		38	76	X	X	X	X	X			
RANGE 18TH INTRUDER	Tens Units	39	77	X	X	X	X	X	20	Binary	Char 73 Bit 2 Intruder 1 Y8 Bit 1 Intruder 2 Y8
		40	78	X	X	X	X	X			
RANGE 19TH INTRUDER	Tens Units	41	39	X	X	X	X	X	21	Binary	Char 73 Bit 2 Intruder 1 Y8 Bit 1 Intruder 2 Y8
		42	82	X	X	X	X	X			
RANGE 20TH INTRUDER	Tens Units	43	56	X	X	X	X	X	22	Binary	Char 73 Bit 2 Intruder 1 Y8 Bit 1 Intruder 2 Y8
		44	81	X	X	X	X	X			
RANGE 21TH INTRUDER	Tens Units	45	80	X	X	X	X	X	23	Binary	Char 73 Bit 2 Intruder 1 Y8 Bit 1 Intruder 2 Y8
		46	48	X	X	X	X	X			
RANGE 22TH INTRUDER	Tens Units	47	49	X	X	X	X	X	24	Binary	Char 73 Bit 2 Intruder 1 Y8 Bit 1 Intruder 2 Y8
		48	24	X	X	X	X	X			
RANGE 23TH INTRUDER	Tens Units	49	..	X	X	X	X	X	25	Binary	Char 73 Bit 2 Intruder 1 Y8 Bit 1 Intruder 2 Y8
		50	..	X	X	X	X	X			
RANGE 24TH INTRUDER	Tens Units	51	Via	X	X	X	X	X	26	Binary	Char 73 Bit 2 Intruder 1 Y8 Bit 1 Intruder 2 Y8
		52	40	X	X	X	X	X			
RANGE 25TH INTRUDER	Tens Units	53	..	X	X	X	X	X	27	Binary	Char 73 Bit 2 Intruder 1 Y8 Bit 1 Intruder 2 Y8
		54	..	X	X	X	X	X			
RANGE 26TH INTRUDER	Tens Units	55	38	X	X	X	X	X	28	Binary	Char 73 Bit 2 Intruder 1 Y8 Bit 1 Intruder 2 Y8
		56	13	X	X	X	X	X			
RANGE 27TH INTRUDER	Tens Units	57	21	X	X	X	X	X	29	Binary	Char 73 Bit 2 Intruder 1 Y8 Bit 1 Intruder 2 Y8
		58	46	X	X	X	X	X			
RANGE 28TH INTRUDER	Tens Units	59	18	X	X	X	X	X	30	Binary	Char 73 Bit 2 Intruder 1 Y8 Bit 1 Intruder 2 Y8
		60	16	X	X	X	X	X			
RANGE 29TH INTRUDER	Tens Units	61	..	X	X	X	X	X	31	Binary	Char 73 Bit 2 Intruder 1 Y8 Bit 1 Intruder 2 Y8
		62	..	X	X	X	X	X			
RANGE 30TH INTRUDER	Tens Units	63	Via	X	X	X	X	X	32	Binary	Char 73 Bit 2 Intruder 1 Y8 Bit 1 Intruder 2 Y8
		64	40	X	X	X	X	X			
RANGE 31TH INTRUDER	Tens Units	65	..	X	X	X	X	X	33	Binary	Char 73 Bit 2 Intruder 1 Y8 Bit 1 Intruder 2 Y8
		66	96	X	X	X	X	X			
RANGE 32TH INTRUDER	Tens Units	67	97	X	X	X	X	X	34	Binary	Char 73 Bit 2 Intruder 1 Y8 Bit 1 Intruder 2 Y8
		68	98	X	X	X	X	X			
RANGE 33TH INTRUDER	Tens Units	69	57	X	X	X	X	X	35	Binary	Char 73 Bit 2 Intruder 1 Y8 Bit 1 Intruder 2 Y8
		70	83	X	X	X	X	X			
RANGE 34TH INTRUDER	Tens Units	71	84	X	X	X	X	X	36	Binary	Char 73 Bit 2 Intruder 1 Y8 Bit 1 Intruder 2 Y8
		72	59	X	X	X	X	X			
RANGE 35TH INTRUDER	Tens Units	73	65	X	X	X	X	X	37	Binary	Char 73 Bit 2 Intruder 1 Y8 Bit 1 Intruder 2 Y8
		74	64	X	X	X	X	X			
RANGE 36TH INTRUDER	Tens Units	75	88	X	X	X	X	X	38	Binary	Char 73 Bit 2 Intruder 1 Y8 Bit 1 Intruder 2 Y8
		76	87	X	X	X	X	X			
RANGE 37TH INTRUDER	Tens Units	77	89	X	X	X	X	X	39	Binary	Char 73 Bit 2 Intruder 1 Y8 Bit 1 Intruder 2 Y8
		78	90	X	X	X	X	X			
RANGE 38TH INTRUDER	Tens Units	79	91	X	X	X	X	X	40	Binary	Char 73 Bit 2 Intruder 1 Y8 Bit 1 Intruder 2 Y8
		80	..	X	X	X	X	X			

\*\* TACAN DATA MULTIPLEXED  
\*\*\* TRIGGER IS TEST POINT ON PROGRAMMER FOR THE PREVIOUS OCTAVE

Figure II-8. AVOID-1 - DDI Data Format For Recorder Interface

NADC-75056-60

and TAU for intruders 1 and 2 in nmi, knots and seconds; TACAN range and bearing; own altitude; fruit replies received; interrogations transmitted; and interrogations received. A sample Section 2 print-out is shown in Figure II-10 and the nomenclature in Table II-3.

A

FLIGHT NO. 8

ENCOUNTER NO. 14

DATE 7

TIME			DISPLAY	TARGET NO. 1				TARGET NO. 2				ALT	MPLS	I
HR	MIN	SEC		RANGE	EATE	TAU	THK 1	RANGE	EATE	TAU	THK 2			
13	11	10.75		47.9	540	88		48.0	510	90		10.0	2.5	30
13	11	20.52		39.0	530	74		0.0	-0	0		10.0	78.5	14
13	11	33.00		36.4	510	71		0.0	-0	0		10.0	78.8	14
13	11	36.17		34.7	520	66		0.0	-0	0		10.0	78.8	17
13	11	39.35		33.1	500	60	13A	0.0	-0	0		10.0	78.5	15
13	11	42.50	>00A	31.5	520	60	13A	0.0	-0	0		10.0	78.7	17
13	11	45.70	>00A	29.9	490	61	13A	0.0	-0	0		10.0	78.6	15
13	11	48.89	>00A	28.3	510	55	13A	0.0	-0	0		10.0	78.6	15
13	11	52.07	>00A	26.7	490	54	13A	0.0	-0	0		10.0	78.7	15
13	11	55.22	>00A	25.2	510	49	13A	0.0	-0	0		10.0	78.7	17
13	11	58.39	>00A	23.7	490	48	13A	0.0	-0	0		10.0	78.7	15
13	12	1.28	>00A	22.2	490	45	13A	0.0	-0	0		10.0	78.7	15
13	12	4.72	>00A	20.6	500	41	13A	0.0	-0	0		10.0	78.8	17
13	12	7.91	>00A	19.1	480	39	13A	0.0	-0	0		10.0	78.8	14
13	12	11.08	>00A	17.7	470	37	13A	0.0	-0	0		10.0	78.5	15
13	12	14.27	>00A	16.2	450	36	13A	0.0	-0	0		10.0	78.5	15
13	12	17.45	>00A	14.9	420	35	13A	0.0	-0	0		10.0	78.4	15
13	12	20.61	>00A	13.6	410	33	13A	0.0	-0	0		10.0	78.7	17
13	12	23.80	>00A	12.5	370	33	13A	0.0	-0	0		10.0	78.9	17
13	12	26.95	>00A	11.4	360	31	13A	0.0	-0	0		10.0	78.6	17
13	12	30.13	>00A	10.5	290	36	13A	0.0	-0	0		10.0	78.5	17
13	12	33.31	>00A	9.7	240	40	13A	0.0	-0	0		10.0	78.7	18
13	12	36.49	>00A	9.3	160	50	13A	0.0	-0	0		10.0	78.7	20
13	12	39.68	>00A	9.1	70	30	13A	0.0	-0	0		10.0	78.9	20
13	12	42.82	>00A	9.2	-30	99	13A	0.0	-0	0		10.0	78.8	18
13	12	49.18		10.2	-220	99		0.0	-0	0		10.0	78.6	20
13	12	52.32		11.1	-230	99		11.1	-300	99		10.0	32.3	30
13	13	58.00		39.9	-320	99		0.0	-0	0		10.0	2.7	30
13	13	00.17		41.6	-530	99		0.0	-0	0		10.0	2.7	30
13	14	2.20		44.9	-540	99		44.9	-510	99		10.0	2.7	30
13	14	5.87		48.0	-530	99		0.0	-0	0		10.0	2.7	30
13	14	8.86		48.2	-540	99		0.0	-0	0		10.0	2.7	30
13	14	12.00		48.0	-520	99		0.0	-0	0		10.0	2.8	30
13	14	15.19		51.6	-520	99		51.6	-520	99		10.0	2.7	30
13	14	18.36		53.2	-520	99		0.0	-0	0		10.0	2.8	30
13	14	21.54		54.9	-540	99		54.9	-540	99		10.0	2.8	30
13	14	24.69		58.0	-530	99		0.0	-0	0		10.0	2.8	30
13	14	27.86		58.2	-500	99		58.2	-540	99		10.0	2.8	30
13	14	31.05		59.0	-500	99		0.0	-0	0		10.0	2.9	30
13	14	34.19		61.5	-510	99		61.5	-510	99		10.0	2.9	30
13	14	37.39		63.1	-510	99		0.0	-0	0		10.0	2.8	30
13	14	40.55		64.7	-540	99		0.0	-0	0		10.1	2.7	30
13	14	43.69		68.2	-470	99		0.0	-0	0		10.1	2.6	30
13	14	46.86		67.9	-510	99		67.9	-510	99		10.1	2.6	30
13	14	50.23		71.1	-530	99		70.9	-490	99		10.1	2.7	30
13	14	53.38		72.6	-530	99		0.0	-0	0		10.1	2.7	30
13	14	56.58		74.2	-520	99		74.2	-520	99		10.1	2.7	31
13	15	2.73		75.9	-530	99		0.0	-0	0		10.1	2.7	31
13	15	5.88		77.5	-530	99		77.5	-530	99		10.1	2.7	30
13	15	9.08		79.0	-470	99		0.0	-0	0		10.1	2.7	30

5

DATE 7 1

IR 2 ALT MPLS IXMT IRCD

10.0	2.5	30	31			0
10.0	78.5	14	1633			0
10.0	78.8	11	1678			0
10.0	78.8	17	1638			0
10.0	78.5	15	1636	P5		0
10.0	78.7	17	1654	P5		0
10.0	78.6	15	1668	P5		0
10.0	78.6	15	1646	P5		0
10.0	78.7	15	1654	P5		0
10.0	78.7	17	1664	P5		0
10.0	78.7	15	1643	P5		0
10.0	78.7	15	1680	P5		0
10.0	78.8	17	1654	P5		0
10.0	78.8	14	1676	P5		0
10.0	78.5	15	1648	P5		0
10.0	78.5	15	1654	P5		0
10.0	78.4	15	1651	P5		0
10.0	78.7	17	1622	P5		0
10.0	78.9	17	1669	P5		0
10.0	78.6	17	1645	P5		0
10.0	78.5	17	1656	P5		0
10.0	78.7	18	1666	P5		0
10.0	78.7	20	1646	P5		0
10.0	78.9	20	1681	P5		0
10.0	78.8	18	1683	P5		0
10.0	78.6	20	1649	P5		0
10.0	32.3	30	662			0
10.0	2.7	30	55			0
10.0	2.7	30	46			0
10.0	2.7	30	57			0
10.0	2.7	30	60			0
10.0	2.7	30	57			0
10.0	2.8	30	57			0
10.0	2.7	30	49			0
10.0	2.8	30	54			0
10.0	2.8	30	59			0
10.0	2.8	30	62			0
10.0	2.8	30	64			0
10.0	2.9	30	65			0
10.0	2.9	30	64			0
10.0	2.8	30	58			0
10.1	2.7	30	48			0
10.1	2.6	30	41			0
10.1	2.6	30	41			0
10.1	2.7	30	53			0
10.1	2.7	30	58			0
10.1	2.7	31	55			0
10.1	2.7	31	53			0
10.1	2.7	30	60			0
10.1	2.7	30	54			0

Figure II-9. Computer Print-Out Of In-Flight Data Section 1

A

TIME	DISPLAY	TARGET NO.1				TACAN				
		RANGE	RATE	TAU	RANGE	RATE	ALT.			
12 48 13.93		18.460	82	87	0.000	)	0	10.0	9.050	75.9
12 48 20.34		18.001	124	53	0.000	)	0	9.9	9.200	77.21
12 48 23.53		18.170	124	49	18.170	124	90	9.9	9.250	77.7
12 48 20.75		18.005	159	35	0.000	)	0	9.9	9.250	78.7
12 48 24.34		17.807	242	20	17.807	242	90	9.9	9.250	79.51
12 48 33.14		17.610	236	17	0.000	)	0	10.0	9.225	80.21
12 48 42.74		16.800	331	4	16.800	331	90	10.0	9.025	82.21
12 48 45.90		0.035	-41	99	0.000	)	0	10.0	8.950	82.7
12 48 49.15		10.310	325	30	16.310	325	90	10.0	8.800	83.7
12 48 52.34		16.030	314	90	0.000	)	0	10.0	8.650	84.21
12 48 55.50		15.701	307	90	15.704	337	90	10.0	8.475	85.51
12 48 58.74		15.388	307	90	0.000	)	0	10.0	8.300	85.01
12 49 1.32		15.059	307	90	15.059	402	90	10.0	8.150	84.51
12 49 5.15		14.730	355	90	0.000	)	0	10.0	8.075	85.51
12 49 8.35		14.401	307	90	14.401	307	90	10.0	7.875	85.01
12 49 11.52		14.071	307	90	0.000	)	0	10.0	7.725	84.7
12 49 14.74		13.775	307	90	13.775	307	90	10.0	7.550	84.01
12 49 17.93		13.465	355	90	0.000	)	0	10.0	7.375	84.01
12 49 21.13		13.135	367	90	13.133	367	90	10.0	7.250	85.21
12 49 24.34		12.804	367	90	0.000	)	0	10.0	7.100	85.01
12 49 27.54		12.475	331	90	12.432	337	90	10.0	6.950	85.51
12 49 30.75		12.140	391	90	0.000	)	0	10.0	6.775	85.01
12 49 33.95		11.833	391	90	11.830	351	90	10.0	6.625	86.21
12 49 37.14		11.504	361	90	0.000	)	0	10.0	6.500	85.71
12 49 40.35		11.191	355	90	11.131	379	90	10.0	6.325	85.21
12 49 43.55		10.862	379	90	0.000	)	0	10.0	6.150	86.21
12 49 46.75		10.550	379	90	10.550	379	90	10.0	5.975	86.21
12 49 49.91		10.220	367	90	0.000	)	0	10.0	5.875	83.71
12 49 53.10		9.900	367	90	9.900	337	90	10.0	5.725	87.21
12 49 56.32		9.578	379	90	0.000	)	0	10.0	5.550	85.71
12 49 59.51		9.233	379	87	9.233	379	87	10.0	5.400	86.21
12 50 2.71		8.904	379	84	0.000	)	0	10.0	5.225	87.51
12 50 5.92		8.591	373	82	8.591	335	77	10.0	5.150	87.71
12 50 9.12		8.262	365	77	0.000	)	0	10.0	4.975	88.21
12 50 12.32		6.303	365	58	0.000	)	0	10.0	4.050	90.51
12 50 15.40	500A	5.974	379	55	0.000	)	0	10.0	3.925	88.21
12 50 18.47	500A	5.645	367	55	0.000	)	0	10.0	3.775	87.01
12 50 21.50	500A	5.315	373	51	0.000	)	0	10.0	3.625	85.01
12 50 24.59	500A	4.987	373	40	0.000	)	0	10.0	3.500	84.51
12 50 27.61	500A	4.658	373	44	0.000	)	0	10.0	3.300	85.01
12 50 30.70	500A	4.328	379	41	0.000	)	0	10.0	3.175	86.71
12 50 33.71	500A	4.000	373	38	0.000	)	0	10.0	3.075	84.71
12 50 36.71	500A	3.677	379	31	0.000	)	0	10.0	2.800	82.71
12 51 3.00	500A	3.045	379	28	0.000	)	0	10.0	2.650	78.51
12 51 6.02	500A	2.710	367	26	0.000	)	0	10.0	2.500	77.51
12 51 9.01	500A	2.403	367	23	0.000	)	0	10.0	2.350	92.01
12 51 12.00	500A	2.074	367	20	0.000	)	0	10.0	2.275	97.71
12 51 15.12	500A	1.761	355	17	0.000	)	0	10.0	2.150	104.51
12 51 18.21	500A	1.448	361	14	0.000	)	0	10.0	2.100	94.21
12 51 21.55	500A	1.152	337	12	0.000	)	0	10.0	1.950	71.71

5

TACAN						
TAU	ALT.	RANGE	BEARING	RPLS	IXMT	IRCD
0	10.0	9.050	75.50	3.4	30	49
0	9.9	9.200	77.25	3.8	32	53
0	9.9	9.250	77.75	3.7	31	59
0	9.9	9.250	78.75	3.5	30	37
0	9.9	9.250	79.50	3.6	31	38
0	10.0	9.225	80.25	3.6	32	46
0	10.0	9.025	82.25	3.8	30	58
0	10.0	8.950	82.75	3.8	31	55
0	10.0	8.800	83.75	3.8	32	53
0	10.0	8.650	84.25	3.7	32	59
0	10.0	8.475	85.50	3.5	31	60
0	10.0	8.300	85.00	3.4	30	62
0	10.0	8.150	84.50	3.4	30	55
0	10.0	8.075	85.50	3.2	30	60
0	10.0	7.875	85.00	3.2	30	61
0	10.0	7.725	84.75	3.0	30	60
0	10.0	7.550	84.00	3.0	30	55
0	10.0	7.375	84.00	3.1	30	54
0	10.0	7.250	83.25	3.1	30	56
0	10.0	7.100	85.00	3.0	30	61
0	10.0	6.950	85.50	3.0	30	55
0	10.0	6.775	85.00	3.0	30	61
0	10.0	6.625	86.25	3.0	30	59
0	10.0	6.500	85.75	3.0	30	61
0	10.0	6.325	85.25	2.9	30	57
0	10.0	6.150	86.25	2.9	30	57
0	10.0	5.975	86.25	2.9	30	58
0	10.0	5.875	83.75	2.9	30	56
0	10.0	5.725	87.25	2.8	30	58
0	10.0	5.550	85.75	2.9	30	58
87	10.0	5.400	86.25	2.7	30	44
0	10.0	5.225	87.50	2.7	30	34
77	10.0	5.150	87.75	2.7	30	38
0	10.0	4.975	88.25	2.8	30	36
0	10.0	4.050	90.50	79.2	13	1684
0	10.0	3.925	88.25	79.2	15	1690
0	10.0	3.775	87.00	79.4	14	1699
0	10.0	3.625	85.00	79.5	13	1679
0	10.0	3.500	84.50	79.3	17	1679
0	10.0	3.300	85.00	79.4	15	1701
0	10.0	3.175	86.75	79.3	16	1701
0	10.0	3.075	84.75	79.6	17	1709
0	10.0	2.800	82.75	79.4	13	1697
0	10.0	2.650	78.50	79.3	17	1693
0	10.0	2.500	77.50	79.5	17	1733
0	10.0	2.350	92.00	79.5	17	1745
0	10.0	2.275	97.75	79.4	17	1718
0	10.0	2.150	104.50	79.5	15	1705
0	10.0	2.100	94.25	79.3	17	1702
0	10.0	1.950	71.75	79.5	17	1670

Figure II-10. Computer Print-Out Of In-Flight Data Section 2

Table II-3 COMPUTER PRINT-OUT NOMENCLATURE

- Display** - a print-out of what the pilot sees displayed on his CAS/VSI indicator
- Examples:**
- 200 ANT - limit vertical speed up to 200 fpm, do not turn
  - 1000 BNT - limit vertical speed down to 1000 fpm, do not turn
  - 1000 A 200 BNT - limit vertical speed up to 1000 fpm, limit vertical speed down to 200 fpm, do not turn
  - CLIMBNT - climb, do not turn
- Target No. 1** - that target which is closest in range in the first altitude band interrogated containing targets
- Target No. 2** - that target which is closest in range in the next altitude band containing a target
- Range** - The slant range between own aircraft and intruder aircraft in thousands of feet (Section 1); nmi (Section 2)
- Rate** - The first derivative of slant range with respect to time in feet per second (Section 1); knots (Section 2)
- TAU** - the range divided by the range rate - the time to collision if two aircraft are on a collision course in seconds
- THR 1** - the threat status of target No. 1 inputted to the threat logic matrix the output of which is displayed on the CAS/VSI indicator
- Examples:**
- CB1 - coaltitude below TAU 1
  - CB2 - coaltitude below TAU 2
  - CAL - coaltitude above TAU 1
  - 13A -  $\leq 1300$  feet above
  - 20A -  $\leq 2000$  feet above
  - 32A -  $\leq 3200$  feet above
  - 13B -  $\leq 1300$  feet below

Table II-3 COMPUTER PRINT-OUT NOMENCLATURE (continued)

- 20B -  $\leq 2000$  feet below  
 32B -  $\leq 3200$  feet below  
 13A PCA -  $\leq 1300$  feet above predicted coaltitude  
 20BPCA -  $\leq 2000$  feet below predicted coaltitude
- THR 2 - the threat status of target No. 2 inputted to the threat logic matrix
- ALT - own altitude derived from digitizing barometric altimeter - thousands of feet
- RPLS - the sum of real, and simulated target replies from the traffic simulator injected into the front end of the AVOID receiver (representing aircraft replies (fruit) to interrogations other than those from own aircraft) in hundreds of pulses per second
- I XMT - the number of times the AVOID CAS interrogates the aircraft population - pulse quads per second
- I RCD - the number of interrogations received by the AVOID from the aircraft population.
- ALL THREATS - Since the digital display and interface contains only two tracking channels, it is desirable to have the capability of displaying the threat status of additional targets; this is accomplished in the print-out of the ALL Threats Data (intermediate display logic)

## Examples:

- P20 -  $\leq 3200$  feet above  
 P10 -  $\leq 2000$  feet above  
 P5 -  $\leq 1300$  feet above  
 PCA - predicted coaltitude above  
 T2A - coaltitude TAU 2 above  
 T1A - coaltitude TAU 1 above  
 T1B - coaltitude TAU 1 below  
 T2B - coaltitude TAU 2 below  
 PCB - predicted coaltitude below  
 M5 -  $\leq 1300$  feet below  
 M(10) -  $\leq 2000$  feet below  
 M(20) -  $\leq 3200$  feet below  
 (EA1) - equal altitude TAU 1 above target initially  $>+100$  feet above finally within  $\pm 50$  feet  
 (EA 2) - equal altitude TAU 2 above target initially  $>+100$  feet above finally within  $\pm 50$  feet

Table II-3 COMPUTER PRINT-OUT NOMENCLATURE (continued)

- (EB1) - equal altitude TAU 1 below target initially <-100 feet below finally within  $\pm 50$  feet
- (EB2) - equal altitude TAU 2 below target initially <-100 feet below finally within  $\pm 50$  feet
- (EA2 B2) - coaltitude TAU 2 within  $\pm 50$  feet
- (EA1 B1) - coaltitude TAU 1 within  $\pm 50$  feet
- (TA) - TAU 2 or TAU 1 above within +100 feet to +400 feet
- (TB) - TAU 2 or TAU 1 below within -100 feet to -400 feet
- BIAS - To ensure complementary vertical maneuvers in a TAU 1 situation, when the altitude separation is measured as  $\approx 400$  feet, the responding aircraft, which has assessed the threat, biases the altitude with which he responds by 200 feet in the direction of the escape maneuver
- Examples:
- (+) own altitude biased +200 feet
- (-) own altitude biased -200 feet
- TACAN Range - Range in nautical miles to TACAN beacon (air-to-ground mode); range nmi between aircraft (air-to-air mode) to nearest thousandth of a mile
- TACAN Bearing - Bearing in degrees of the TACAN radial being flown to nearest hundredth of a degree (air-to-ground mode); bearing to another aircraft (air-to-air) not available yet

## CHAPTER III

## LABORATORY TESTS

## INTRODUCTION

This chapter contains laboratory tests of the link sensitivity, transponding and reply sensitivities, power budget, range and range rate accuracies as a function of fruit, round time, and threat logic. The laboratory tests of the co-range and false alarm properties of the AVOID I (which comprised the major portion of the laboratory tests) are contained in Chapter VIII, together with the actual in-flight false alarm data and analysis. The primary purpose of the laboratory tests was to establish that the CAS in fact had the required characteristics to make flight testing worthwhile.

## LINK SENSITIVITY

This test was one of the first tests performed since the link sensitivity between two airborne CAS equipments determines the maximum distance over which communications can be maintained reliably. The test setup is shown in Figure III-1. One AVOID I was operated inside the screen room and one outside the screen room. The two were connected to each other by means of a calibrated 150-foot delay line and a calibrated variable attenuator. Suitable altimeter inputs were provided to each AVOID to establish a co-altitude situation. CAS displays, both of which were visible to the engineer in the screen room were connected to each AVOID I; one display had a climb command; the other a dive command. The criteria used to establish the link sensitivity was the maximum attenuation which could be inserted between the two AVOID I's without experiencing a single missed display in 100 rounds.

Table III-1 is a tabulation of the link sensitivities of all the possible AVOID link combinations for the three AVOID I's delivered. As can be seen, the link sensitivities are well balanced being within  $\pm 1.3$  db of a nominal 131.8 db. It is to be noted that this test is much preferred to individual measurements of output power and receiver sensitivity insofar as the overall link operation is concerned for the following reasons: (1) the measurements are reliable and a complete system check-out can be performed in a reasonable length of time, (2) the possibility of the center frequency of the receiver being off is automatically taken into consideration, and (3) the pulse and spectrum characteristics of the transmitter are automatically taken into consideration.

## RECEIVER SENSITIVITY

The reply and transponding sensitivities of the AVOID receivers were measured by means of the calibrated signals originating in the traffic

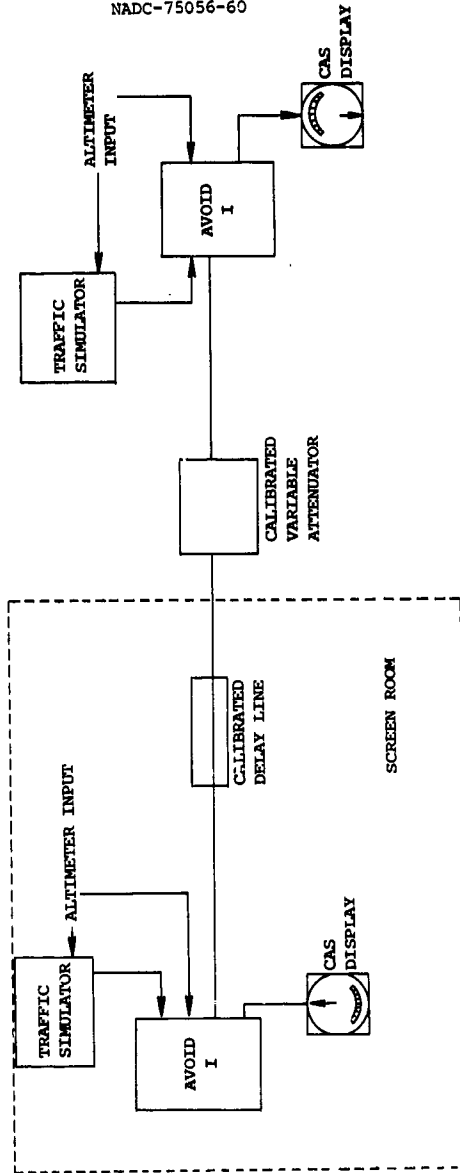

Figure III-1. Link Sensitivity Test Set-Up.

TABLE III-1. LINK SENSITIVITIES OF ALL OF THE POSSIBLE LINK COMBINATIONS OF THE THREE AVOID I EQUIPMENTS AT FRUIT RATE OF 32K/1536 AND 64K/1536\*

AVOID Serial Number  B - Bottom T - Top	Attenuation in the Link  db
1B to 2B	131.0
1B to 2T	131.0
1T to 2B	131.0
1T to 2T	130.5
1B to 3B	132.0
1B to 3T	132.0*
1T to 3B	133.0
1T to 3T	132.0
2B to 3B	132.0
2B to 3T	133.0*
2T to 3B	131.0
2T to 3T	130.5

simulator. The reply sensitivity was determined by gradually increasing the signal level of the replies from the traffic simulator until the AVOID I receiver under test began to track the simulated target. Then the signal level was raised in steps of 0.5 db until a signal level was reached where there were a minimum of 99 successful tracks out of 100. The transponding sensitivity was determined by gradually increasing the attenuation in the loop by means of an attenuator on the traffic simulator until a point was reached where the AVOID I failed to respond to an interrogation. The presence of responses was averaged and indicated by a green light on the front panel of the traffic simulator. The attenuation was then decreased until the indicator stopped blinking.

From the results in Table III-2, it will be seen that the reply sensitivities of the six receivers were within  $\pm 0.8$  db of a nominal 75.3 db and the transponding sensitivities were within  $\pm 1.0$  db of a nominal 74.5 db.

#### POWER BUDGET

Based on the link sensitivity and receiver sensitivity measured in the screen room tests, the effective power budget is the following:

Transmitted power	+ 57.3 dbm
Receiver sensitivity	<u>- 74.5 dbm</u>
Link sensitivity	131.8 db
Antenna lead in losses (total for both acft)	4.0 db
Path loss for 15 nmi	<u>124.0 db</u>
Total path losses	128.0 db
Theoretical margin (assuming +1 db forward gain in each acft)	5.8 db

#### RANGE AND RANGE RATE ERRORS

Range rate errors were determined in the laboratory by setting up on the traffic simulator a moving target at a fixed closing rate and fixed signal level without fruit and at fruit levels of 16K/1536, 32K/1536 and 64K/1536. The mean range rate error and standard deviation were then calculated from the data. Figure III-2 depicts a set of these error curves for a target closing at 59.2 knots at a signal level of -70dbm. At zero fruit rate, the mean error was +2.4 knots with a sigma of 4.4 knots. The errors increased with fruit reaching a mean error of +4.1 knots with a sigma of 6.6 knots at a fruit rate of 64/1536.

TABLE III-2. RECEIVER REPLY AND TRANSPONDING SENSITIVITIES

AVOID Serial Number	Receiver Sensitivity - DBM	
	Reply	Transponding
#1 Bottom	-74.5	-73.5
#1 Top	-75.0	-74.0
#2 Bottom	-75.0	-75.0
#2 Top	-75.5	-75.0
#3 Bottom	-76.0	-75.5
#3 Top	-75.5	-74.5

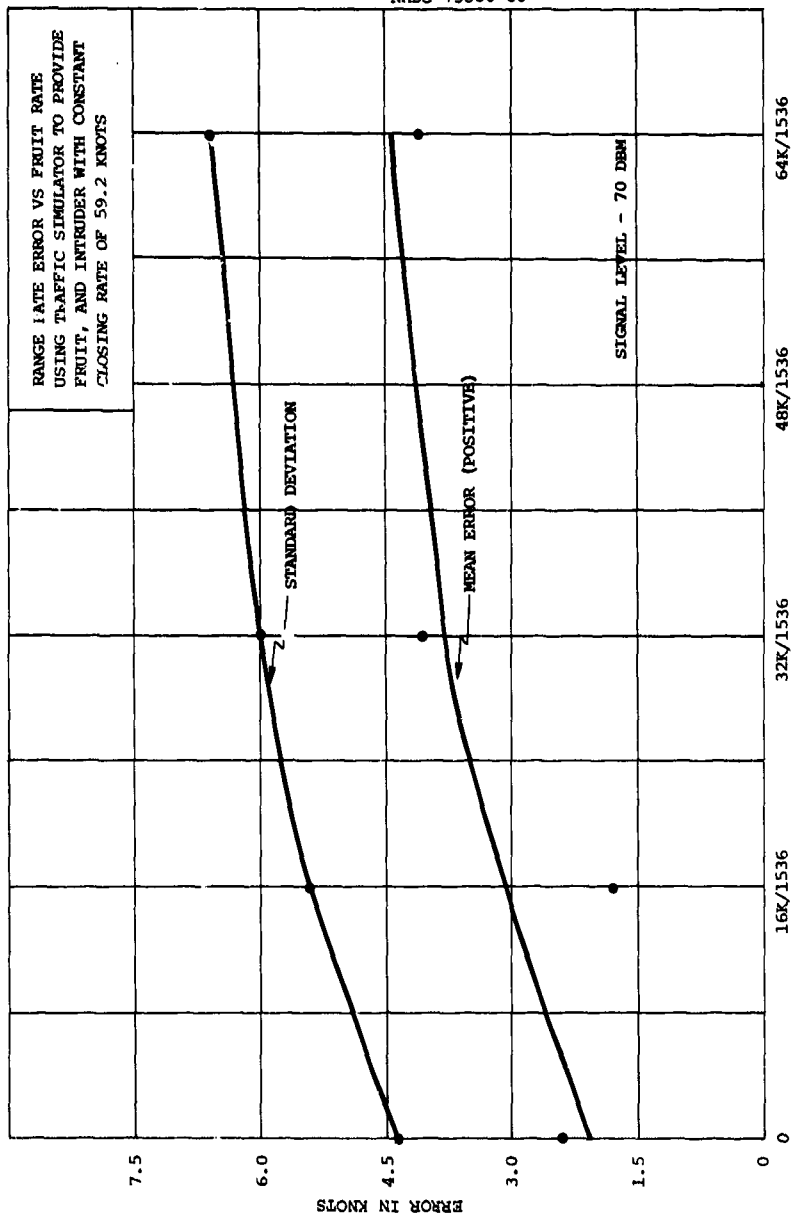

Figure III-2. Range Rate Error Versus Fruit Rate.

Range errors were determined in the same basic way with the exception that a fixed intruder was substituted for the moving target. From Figure III-3, it can be seen that the mean error at a zero fruit rate was +97 feet decreasing gradually with increasing fruit rate to 91 feet at 96K/1536. The standard deviation at zero fruit rate was zero feet and steadily increased with increasing fruit rate to 31 feet at 96K/1536.

#### ROUND TIME

On one of the NAVAIRDEVCON computer programs for AVOID I data reduction, the time interval (round time) between events was printed out in addition to the basic threat data. Thus, the upper and lower bounds of the round times for intruders  $\leq 1300$  feet and intruders  $> 1300$  feet could be determined with fruit rate as a parameter.

The round time results at fruit rates from zero to 64K/1536 are tabulated in Table III-3.

TABLE III-3. MEASURED ROUND TIMES

Intruder Altitude Differential - Feet	Round Time - Seconds	Fruit
$\leq 1300$	$3.2 \pm 0.2$	0 to 64K/1536
$> 1300$	$6.5 \pm 0.2$	0 to 64K/1536

It can be seen that the round time for intruders  $\leq 1300$  feet was within  $\pm 0.2$  seconds of a nominal 3.2 seconds. This applies to all TAU 1 and TAU 2 coaltitude commands, predicted coaltitude commands and non-coaltitude advisories within a  $\pm 1300$  foot altitude differential. Predicted coaltitude commands and non-coaltitude advisories at altitude differentials greater than  $\pm 1300$  feet had a round time within  $\pm 0.2$  seconds of a nominal 6.5 seconds.

#### THREAT LOGIC

In order to establish that the altitude threat zones complied with ANTC-117 the traffic simulator was used to place intruders at altitude

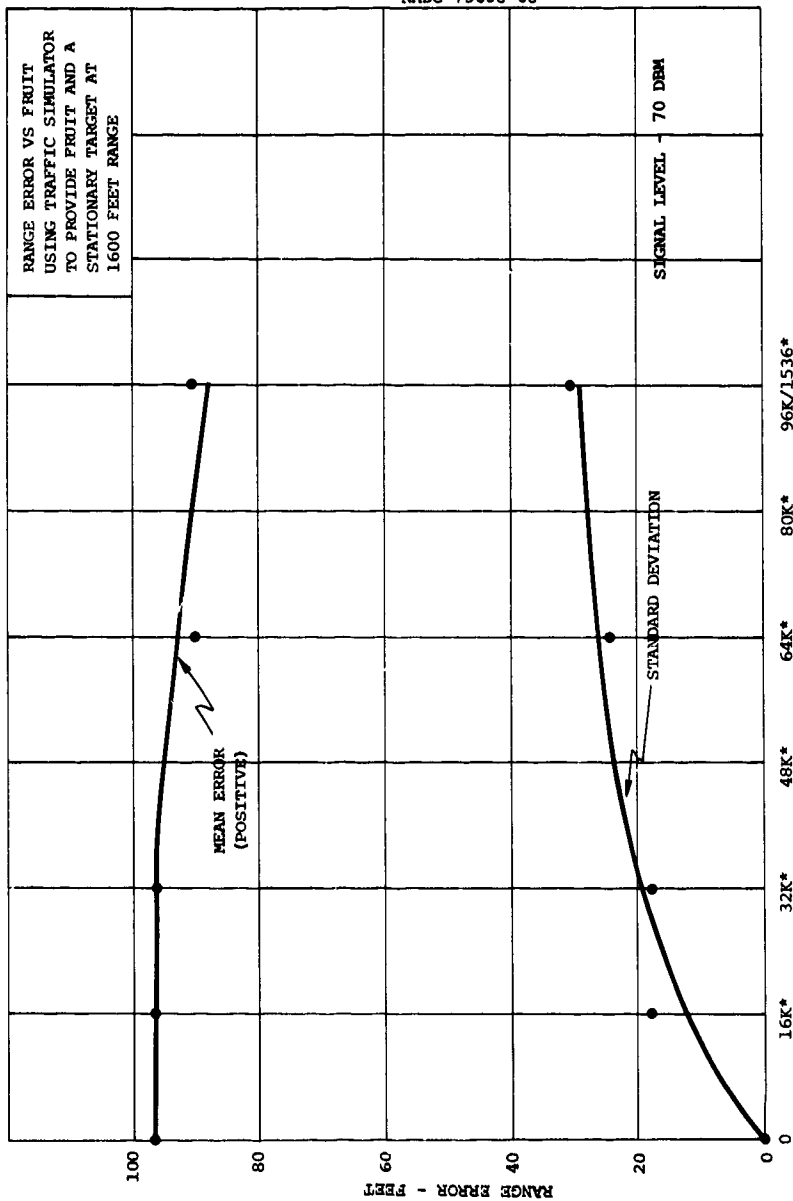

Figure III-3. Range Error Versus Fruit Rate.

differentials within each altitude zone, 100 feet below the boundary, at the boundary, and 100 feet above the boundary. This procedure was followed for the 9500 feet and below logic and the above 9500 feet logic which shifts the coaltitude boundary from  $\pm 600$  feet to  $\pm 800$  feet. The 3 aircraft logic was exercised for compliance by using 2 traffic simulators so that 2 intruders could be arranged in the required configurations: 2 intruders above, 2 intruders below, and 1 intruder above and 1 intruder below. To check the predicted coaltitude band accuracies, vertical rate signals were used.

The AVOID I threat band implementation departs somewhat from ANTC-117 for intruders with altitude differentials of greater than 1300 feet. The 1800 foot altitude threat zone boundary is established at 2000 feet for the 9500 feet and below regime and at 2200 feet for the above 9500 feet regime. This departure from ANTC-117 is seen to be of little importance since it is in the direction of a more conservative restriction on rate of ascent or descent with intruders between 1800 feet and 2000 feet for the 9500 feet and below regime and 1800 feet and 2200 feet for the above 9500 foot regime. However, by changing the altitude interrogation codes, the exact ANTC-117 boundaries could be implemented.

In the ANTC-117 document, communications is required for intruders within altitude differentials of  $\pm 3300$  feet whether own aircraft is in level flight or ascending or descending at rates up to 2000 feet per minute. The AVOID I CAS, in common with another CAS, departs from that logic on the basis that when in level flight, the altitude differential protection required differs from that required when ascending or descending at 2000 feet per minute. Consequently, the AVOID I in the above 9500 foot regime covers an altitude differential of  $\pm 1300$  feet when in level flight or when ascending or descending at less than 500 fpm, an altitude differential of  $\pm 2200$  feet when ascending or descending at greater than 500 fpm but less than 1000 fpm, and an altitude differential of  $\pm 3200$  feet when ascending or descending at greater than 1000 fpm. In the 9500 feet and below altitude regime the  $\pm 2200$  feet altitude differential is reduced to  $\pm 2000$  feet.

Except for those deviations noted above and occasional boundary errors discussed in detail in Chapter VIII, the AVOID I conformed to ANTC-117 with respect to the altitude threat zones for level flight conditions including ascending and descending at less than 500 fpm and for ascending and descending rates greater than 500 fpm in which the adaptive predicted co-altitude boundaries were employed.

CHAPTER IV

FLIGHT TEST PLAN SUMMARY

INTRODUCTION

The details of the flight test plan are found in reference 4. The primary objectives of these flight tests were to determine:

- a. The communication range as a function of the angle between the flight paths.
- b. The round/display reliability and the effectiveness of the air-to-air data link in the presence of fruit.
- c. The accuracy of AVOID-I range and range rate.
- d. The ability of AVOID-I to provide timely and correct advisories and maneuver commands.

COMMUNICATION RELIABILITY TESTS

The objectives of the RF link (communication reliability) tests were to determine the range at which the required link parameters are established as a function of flight geometry. Specifically, at what distances can target aircraft be detected and tracked for range, range rate, and altitude.

The hazard range for the AVOID I is approximately 7.9 nmi below 10,000 feet of altitude for a closing velocity of 550 knots, and approximately 15 nmi above 10,000 feet of altitude for a closing velocity of 1200 knots. This applies to the head-on encounter case. For other angles between flight paths and various aircraft velocities, the hazard radius is proportionately less. The flights were flown with the artificial injection of fruit signals representing dense traffic in accordance with Honeywell computer simulations.

The RF link and, thus, the hazard detection ability, is directly dependent on antenna patterns. Ideally, the aircraft antenna patterns should favor the forward direction since this is where the greatest closing velocities will occur. However, the flight test included traffic geometries to encompass 360° coverage around the participating aircraft to test adequate hazard detection (in time) for all directions around a protected aircraft.

The flights were run both above and below 10,000 feet to test the use of different power levels as well as the different aircraft velocities.

In addition, tests were run with one aircraft above 10,000 feet and the other aircraft below 10,000 feet to test the "above/below 10,000 feet" mode of operation.

Three aircraft encounters were flown to test the multiple aircraft communication reliability and collision avoidance logic. The patterns flown included "Single Daisy" (see Figure IV-I) where one aircraft flies the figure eight and the other aircraft does 150° turns, head-on and tail chase encounters.

Some of the flights were flown with 6db attenuators in the antenna cable path to simulate communication to twice the distance, and some flights were flown with 9db attenuators to simulate still greater range.

Data derived from these flights included:

- a. Range and range rate between aircraft at first track of each encounter
- b. Plot of range versus angle between flight paths
- c. The round reliability from the first track of each encounter until the first TAU TWO warning
- d. The round and display reliability of TAU TWO and TAU ONE threats
- e. The accuracy of the data link for altitude discrimination
- f. The ability to track multiple targets
- g. The occurrence of false alarms, which include phantoms created by fruit as well as altered alarms created by fruit, poor communication reliability, poor altitude boundary resolution, or other factors.
- h. Statistics on warning time

The AVOID I equipment should be able to detect and evaluate a potential hazard situation in a timely manner to enable safe separation assurance. This necessitates the extrapolation when necessary of the data to "worst case" combination of aircraft velocities to determine just when targets are detected and evaluated in terms of time-to-collision. Ideally, the system should detect and evaluate, as a minimum, all TAU TWO situations nearly 100 percent of the time. However, outside of these minimum requirements, any additional communication range beyond a safety margin for transmitter power variations, etc., should be small to keep the fruit interference problem to a minimum.

ENCOUNTER NUMBER	COURSE FLOWN		ANGLE BETWEEN RADIALS (DEG)
	A/C 1	A/C 2	
1	90	270	180
2	255	75	180
3	90	240	150
4	255	45	150
5	90	210	120
6	255	15	120
7	90	180	90
8	255	345	90
9	90	150	60
10	255	315	60
11	90	120	30
12	255	285	30
13	90	90	0

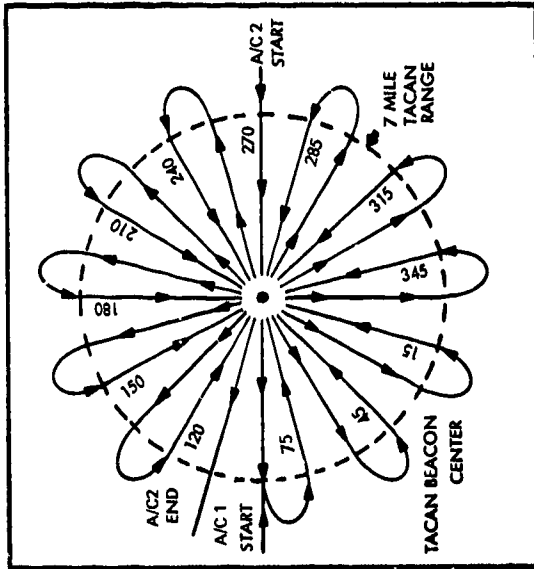

Figure IV-1. Communication Reliability, Single Daisy Over A Figure Eight.

#### SENSOR ACCURACY TESTS

The objective of these tests was to determine the ability of the AVOID I to measure range and range rate to other aircraft. The operating area was the Phototheodolite Range, Naval Air Test Center, Patuxent River, Maryland. Minimum instrumentation accuracy was better than: range 50 ft, 1 sigma and range rate 2 kt, 1 sigma.

Figure IV-2 is a map of the controlled area showing the local coordinate system. Table IV-1 is a description of each type of encounter planned.

Range and range rate were determined from the Phototheodolite tracking system. These were compared with the same quantities measured by the AVOID I.

Primary data derived from these flights include range and range rate accuracy, TAU accuracy, and warning time. Since the flights were over water, significant information on multipath effects was obtained.

#### OPERATIONAL TESTS

The "Operational Test Flights" were performed to examine the capabilities of the vertical maneuver escape logic, and determine conformance with ANTC 117 TAU zone and altitude zone boundaries.

Five maneuver commands are used by the AVOID I. These are the Vertical Maneuver, the Hold Altitude, the Level Off, the Do Not Turn, and the Vertical Speed Restriction.

Tests were conducted to determine the ability of the AVOID I to define the altitude bands. A series of low range rate overtaking runs at specified altitude levels were flown. This allowed evaluation of the equipment capability to determine co-altitude, aircraft above (below) bands, and the altitude "tie breaking" logic. Avoidance maneuvers were not made during these runs. Initial and final altitude separation are specified for each encounter in Table IV-2.

The remaining flights were the TAU zone boundaries and avoidance maneuver tests. CAS warning logic is based upon the quantities TAU (range/range rate), altitude difference ( $\Delta h$ ) and minimum range ( $R_m$ ). Selected values of TAU and minimum range, and differential altitude define TAU zones and altitude bands. An intruding aircraft, on entering into a specific altitude band and TAU zone initiates an advisory warning or avoidance maneuver command to be displayed to the pilot by means of the pilot's cockpit indicator. In response to the maneuver command, the pilot executes an avoidance maneuver.

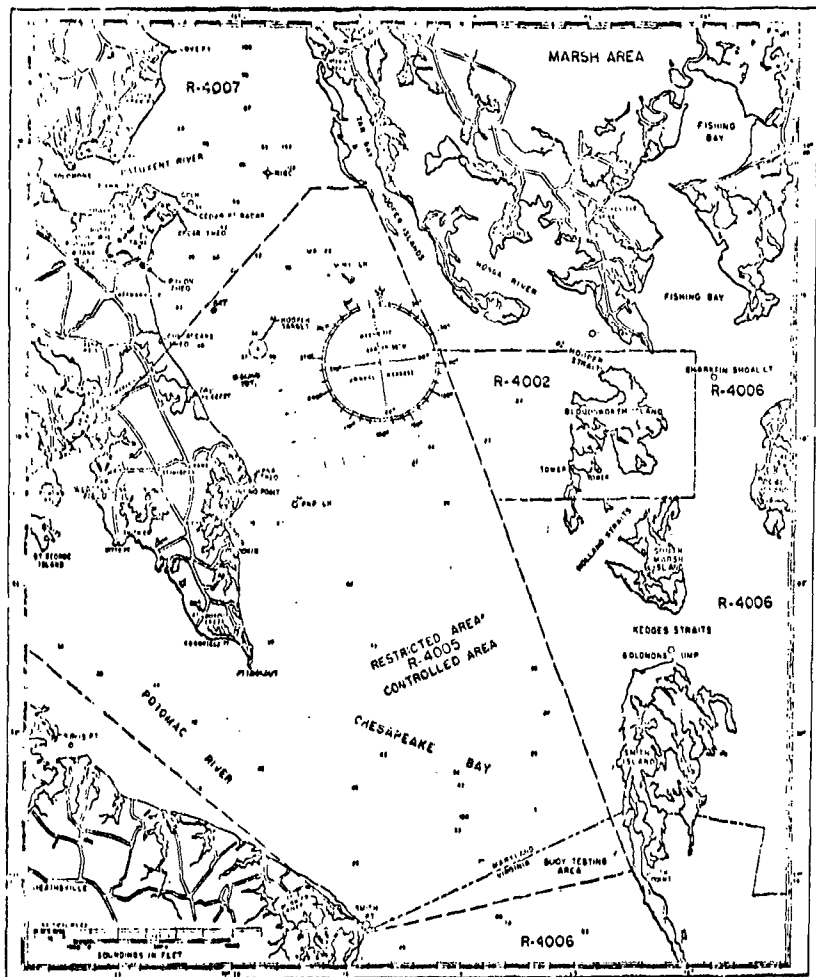

Figure IV-2. WST Range - Controlled Area

TABLE IV-1. THEODOLITE FLIGHT TEST PROFILES

Encounter #	Type of Encounter	A Altitude		Initial A/C 1	Location
		A/C 1	A/C 2		
1	Head-On	4,000	5,000	0, 0 N	10, 0 S
2	"	"	"	10, 0 S	0, 0 N
3	Head-On	4,000	5,000	0, 0 N	10, 0 S
4	"	"	"	10, 0 S	0, 0 N
5	Tail-Chase	4,000	5,000	3, 0 N	-3, 0 N
6	"	"	"	7, 0 S	+13, 0 S
7	Parallel	4,000	4,500	3, 0 N	0,-1 N
8	"	"	"	7, 0 S	10,-1 S

TABLE IV-2. CAS/VSI DISPLAYS ASSOCIATED  
WITH ALTITUDE BOUNDARY PENETRATION

Run No.	INITIAL ALT Separation	FINAL ALT Separation	Display
1	3100	3400 <sup>1</sup>	LVS 2000/No threat
2	3400 <sup>2</sup>	3100	No threat/LVS 2000
3	2200	1900	LVS 2000/LVS 1000
4	1500	1200	LVS 1000/LVS 500
5 <sup>3</sup>	1000	700	LVS 500/Co Alt (above)
5A <sup>3</sup>	800	500	LVS 500/Co Alt (above)
6	600	-200	CoAlt (above)/Coalt (below)
7	-400	+400	CoAlt (below)/Coalt (above)
8	3400	500 <sup>4</sup>	
9	500	3400 <sup>4</sup>	
10	3400	500 <sup>4</sup>	
11	500	3400 <sup>4</sup>	

- NOTES: 1. Altitude change within each run at 200 fpm. DDI set for unrestricted interrogation runs 1 through 4; restricted for runs 5 through 7.
2. Altitude change between runs at 200 fpm with DDI set for restricted interrogation.
3. Run 5A below 10,000 feet; Run 5 above 10,000 feet.
4. Altitude change for runs 8 and 9 at 600 fpm and runs 10 and 11 at 1100 fpm with DDI set for restricted interrogation.

Three cases were planned. For Case A, level flight, non-turning, two aircraft flew a single daisy pattern with an initial altitude separation of 500 feet. Each aircraft obeyed the CAS commands and returned to 500 feet separation after completing each encounter. Similar tests were made with three aircraft at various initial altitude separations. Here, two aircraft flew perpendicular figure eight patterns, and the third aircraft flew the daisy pattern. These encounters also provided data for Communications Range and Round Reliability.

Case B is level flight, turning. Maneuvers in the horizontal plane which generated lateral accelerations are protected against by means of the "no turn" command. Turning maneuvers have the effect of reducing warning time available to effect an avoidance maneuver. "Worst case" conditions of turning maneuvers occur when one or both of two aircraft initially on parallel or slightly convergent courses turn into the other, with both aircraft at approximately the same speed. For this test, the aircraft started in parallel flight at various distances with a 1000 foot altitude separation. Using altimeter simulator boxes, each AVOID I indicated an altitude separation of 500 feet. At a specified time, both aircraft turned into one another and ignored the CAS commands. Each encounter was repeated with the aircraft now obeying the no turn command.

Case C is to determine, for two aircraft encounters, the generation of warning or advisory signals, with aircraft ascending or descending. Maneuvers in the vertical plane (climbs or dives) are regulated by means of the "level off" command or "limit vertical speed" signals. In the AVOID I, the "level off" command is generated by use of own altitude rate ( $\dot{h}$ ) and a comparison of altitude difference,  $\Delta h$ , with the predicted co-altitude zone. The logic within the CAS first examines the altitude threat by comparing transmitting aircraft altitude data relative to own aircraft altitude data. On the basis of this evaluation, the equipment classifies the altitude threat as:

- a. Co-altitude --  $\Delta h = \text{zero to } \pm 800 \text{ ft}$
- b. Advisory above/below --  $\Delta h = \pm 900 \text{ to } \pm 3300 \text{ feet}$
- c. Predicted co-altitude -- only existing in direction of change when own altitude rate is greater than 500 fpm.  $\Delta h = \pm 800 \text{ feet } \pm (\dot{h} \times 30)$  where  $\dot{h}$  is own altitude rate in fps.

Below 10,000 feet of altitude, the 800/900 foot boundary is reduced to 600/700 feet. When an intruder is within the predicted co-altitude zone boundary and is TAU ONE or TWO, a "level off" command signal is generated. For these encounters, two aircraft fly the daisy pattern with an initial separation of 2000 feet. When the higher aircraft is 1 minute in time from the TACAN ground beacon, it descends into a collision at a rate of 2000 ft/min. The CAS commands are obeyed to provide safe operation.

## CHAPTER V

## AVOID I MODIFICATIONS INCORPORATED DURING FLIGHT TESTS

## INTRODUCTION

This chapter discusses problem areas which were uncovered by NAVAIRDEVCON and the solutions incorporated during the course of the flight tests. Each problem is identified with its solution together with a discussion of the problem, the effectiveness of the modification, and the implication which it poses. In Appendix C, Honeywell describes the AVOID I post shipment modifications and delineates the circuit changes required.

## FALSE ALARMS DUE TO MULTIPATH

Problem

The formation of conditional phantom alarms and alarm alterations due to multipath of the second pulse pair of an interrogation quad forming an illegitimate interrogation quad with the direct path first pulse pair of the same interrogation quad. The multipath signal fell within the altitude acceptance gate of the intruder aircraft, even though a real intruder did not exist in that altitude band.

Solution

To preclude this phenomenon, a multipath guard gate of approximately 5000 nanoseconds was incorporated just ahead of the altitude acceptance gate. Thus, when a pulse pair with 600 nanoseconds spacing is decoded within the guard gate, the altitude acceptance gate is inhibited.

Discussion

Before the modification, when flying over water, multipath of the interrogation pulse pair could form phantom intruders when encountering intruders at non-threatening altitude differentials. These were conditional false alarms since they required an intruder to be present which had exceeded the Tau 1 or Tau 2 threshold. In level flight, if the target aircraft is above our own interrogating aircraft, multipath can cause the formation of a phantom target below our own aircraft such that vertical rate restrictions are imposed due to the real threat above and the phantom threat below.

Figure V-1 is a timing diagram which shows the mechanism by which the conditional phantom alarm can occur. Visualize an aircraft, A, in level flight at an altitude of 5000 feet with an intruder, B, at 6500 feet. The AVOID normally would interrogate the I<sub>+6</sub> and I<sub>-6</sub> basic bands during one interrogation set and then would cease to interrogate since no aircraft was within the altitude differentials encompassed by the I<sub>+6</sub> and I<sub>-6</sub> bands, namely  $\pm 1300$  feet. It will be noted that in the diagram the second pulse pair of the I<sub>+6</sub> direct path interrogation did not fall within aircraft B's altitude acceptance gate; however, due to multipath, a delayed second pulse pair does fall within aircraft B's altitude acceptance gate and does so on all six of the remaining interrogation sets, forming a complete co-altitude Tau track sequence. Thus, even though no command should be displayed, a dive command would be displayed.

A typical flight profile before the multipath modification is shown in Table V-1. The table shows the pilot's display together with the correct display for the NC-117 aircraft flying at 3800 feet altitude over the Chesapeake Bay area (Patuxent River) with the Tau intruder at an altitude of 4800 feet. The proper command was 500A (limit rate of climb to 500 feet per minute).

Commencing at a 6 nautical mile aircraft separation and persisting through 4 nautical miles, the first pulse pair I<sub>-6</sub> interrogations were correlated with multipath of the second pulse pair I<sub>-6</sub> interrogations which fell into the receiving aircraft's altitude acceptance gate. It then responded and this resulted in a Tau track in the I<sub>-6</sub> band, thus forming a phantom target below in addition to the real target above. The resulting command was a "limit vertical speed down to 200 fpm, do not turn" (200 BNT) and a 500A. At 3.5 nautical mile to 3.1 nautical miles aircraft separation, not only did multipath cause a Tau track in the I<sub>-6</sub> band, it also caused altitude correlation in the I<sub>-13</sub> band in the fifth and seventh sets of interrogations, due to the longer multipath delay, as the aircraft came closer to each other. The resulting command was a 500A, 500B. From 2.7 nautical miles to minimum separation, the multipath effects disappeared and the correct command of 500A was displayed.

Alarm alterations occurred when an intruder was in a basic altitude response band and not in the branch altitude band such that the multipath of the second pulse pair of the branch altitude interrogation fell within the altitude acceptance gate of the interrogated aircraft. In ascending flight, greater than 500 fpm, if the target is above the interrogating aircraft, multipath can cause an alarm alteration to a more threatening type. This is correlation in a lower altitude response band on branch interrogations. In level flight, if the target aircraft is below the interrogating aircraft, multipath can cause an alarm alteration to a less threatening type, by correlating in a lower altitude band.

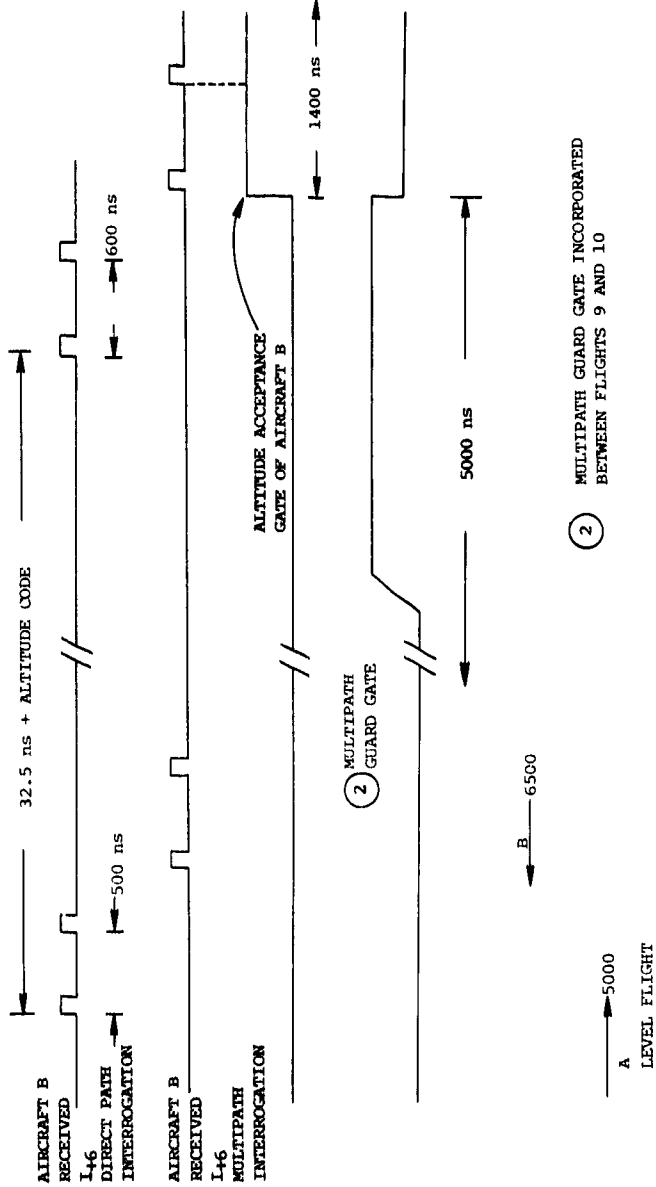

② MULTIPATH GUARD GATE INCORPORATED BETWEEN FLIGHTS 9 AND 10

Figure V-1. Conditional Phantom Intruder Alarm Due to Multipath.

TABLE V-1. FLIGHT OVER WATER SHOWING EFFECT  
OF MULTIPLE PHANTOM INTRUDERS P-3 VERSUS NC-117

Aircraft Separation NMI	Correct Display	Actual CAS Display
6.9	500A	500A
6.4	"	500A
6.1	"	500A 200 BNT
5.8	"	500A 200 BNT
5.1	"	500A 200 BNT
4.8	"	500A 200 BNT
4.3	"	200 BNT
3.9	"	500A 200 BNT
3.5	"	500A 500 B
3.1	"	500A 500 B
2.7	"	500A
2.3	"	500A
1.9	"	500A
1.5	"	500A
1.1	"	500A
0.5	"	500A
0.4	"	500A

NC-117 Print-out of P-3 Flight 8 7/12/74 Encounter 15  
Theodolite Range Chesapeake Bay Area

Figure V-2 shows how such an alarm alteration in level flight can occur.

Visualize an aircraft, A, with an intruder, B, 500 feet below. Aircraft, A, interrogates the I<sub>6</sub> basic band which falls within B's altitude acceptance gate for all seven sets of interrogations. On the fifth and seventh sets of interrogations, A makes branch interrogation in the I<sub>13</sub> band. The I<sub>13</sub> direct path interrogation does not fall within B's altitude acceptance gate but the I<sub>13</sub> multipath interrogation does; on this basis, aircraft A displays a limit vertical speed to 500 fpm below (500B) rather than the correct command of climb.

In Table V-2, a number of the possible phantom intruder alarms and alarm alterations due to multipath over water are tabulated. It covers cases involving level flight (mode one), ascending or descending at between 500 fpm and 1000 fpm (mode two) and ascending or descending at greater than 1000 fpm (mode three). The altitude response band correlation due to the direct interrogation path is shown together with the display that should be present. Also shown is the altitude response band correlation due to multipath alone which must be logically combined with the correlation due to the direct path to obtain the final logical output. The last column shows the actual display under the multipath conditions.

The present solution is a 5000 nanosecond guard gate ahead of the altitude acceptance gate which inhibits replies if one second pulse pair of an interrogation is received in the guard gate interval. This satisfactorily solved the multipath problems encountered during the remainder of the flight tests for the flight profiles flown. However, even with this modification multipath signals whose time of arrival exceeds the direct signal by more than 5000 nanoseconds can be correlated in the altitude gate resulting in an erroneous reply. Therefore, a more general and comprehensive solution is the multipath adaptive guard gate conceived by NAVAIRDEVGEN which would measure the multipath delay of the first pulse pair and set the guard gate of the second pulse pair at that delay. Thus, the interval over which inhibiting takes place would be much narrower and valid interrogations would be honored with a higher probability. In addition, fruit would be less likely to inhibit replies to legitimate interrogations.

#### FALSE ALARMS DUE TO IMPROPER ALTITUDE CORRELATION AT HIGH CLOSING RATES BELOW 9600 FEET

##### Problem

Occasional alteration of an alarm in the 9500 feet and below altitude regime when closing at rates within 65 knots of the upper permissible limit of 540 knots occurred. For targets between 600 and 1300 feet altitude differentials, the alarm was altered to one of greater severity. The

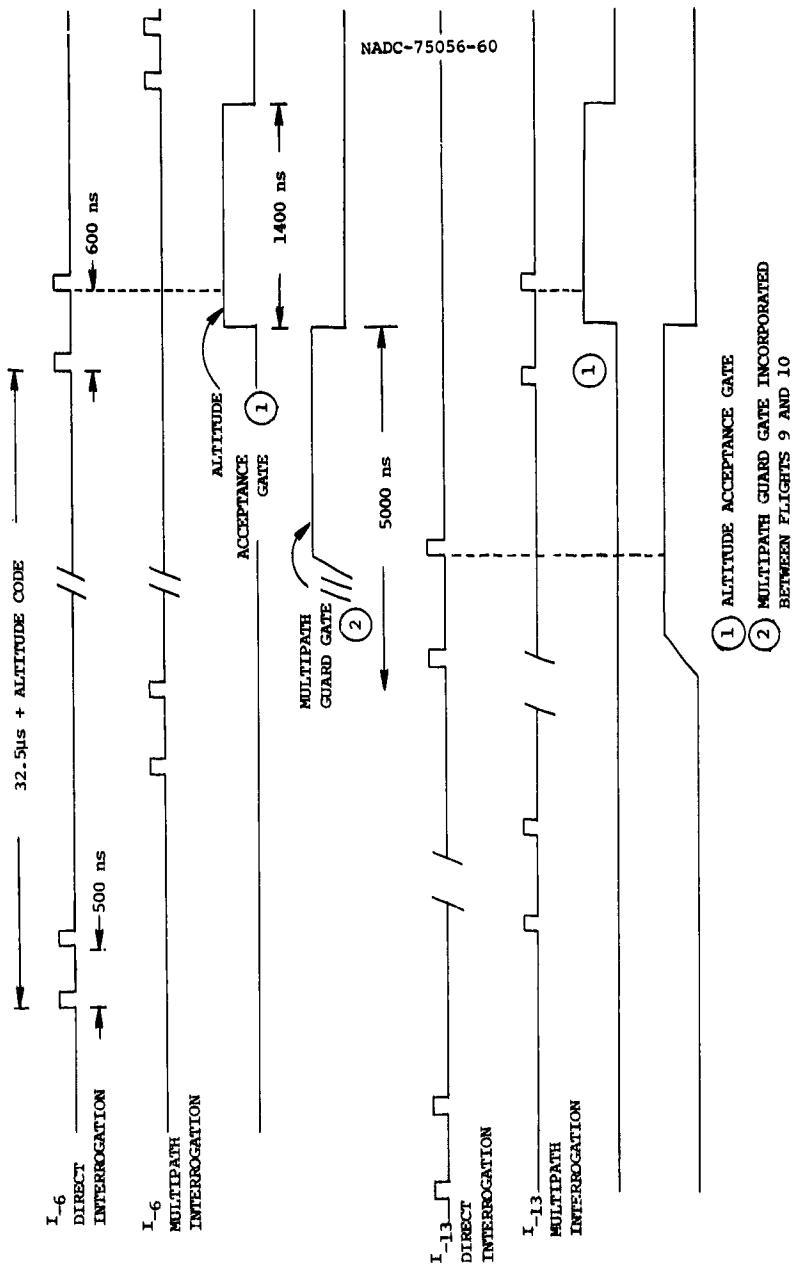

Figure V-2. Conditional Alarm Alteration Due to Multipath.

NADC-75056-60  
 TABLE V-2. PHANTOM INTRUDER ALARMS  
 AND ALARM ALTERATIONS DUE TO MULTIPATH  
 (9500 FEET AND BELOW ALTITUDE REGIME)

Aircraft B Vertical Position Relative To Aircraft A - Feet	Direct Path			Multipath Conditions	
	Aircraft A Vertical Rate FPM	Direct Path Altitude Response Band Correlation	Correct Display	Altitude Response Band Correlation Due To Multipath Alone	Actual Display
2100 Ft Above	+1500 FPM	I+25	2000A	I+13	900A
1400 Ft Above	+ 800 FPM	I+13	1000A	I+6	500A
800 Ft Above	0	I+6 · I+13	500A	I-6	500A 200 BNT
800 Ft Above	0	I+6 · I+13	500A	I-6 · I-13	500A 500B
800 Ft Above	- 800 FPM	I+6 · I+13	500A	I-13	500A 1000B
800 Ft Above	-1500 FPM	I+6 · I+13	500A	I-25	500A 2000B
500 Ft Below	0	I-6 · I-13	Climb	I-13	500B
500 Ft Above	0	I+6 · I+13	Dive	I-6	Level Dive
500 Ft Above	- 800 FPM	I+6 · I+13	Dive	I-13	500B Dive
500 Ft Above	-1500 FPM	I+6 · I+13	Dive	I-25	1000B
1400 Ft Above	0	—	No Threat	I+6 · I+13	500A
1400 Ft Above	0	—	No Threat	I+6	Dive

phenomenon was due to the combination of receiver jitter, bin splitting, and target movement between the  $I_{+6}$  and  $I_{+13}$  interrogations, resulting in responses which fell outside the altitude correlation acceptance gate. Thus, instead of a P5 threat, "limit rate of ascent to 500 fpm," being displayed, the corresponding dive command was displayed. For predicted co-altitude targets, the alarm could be altered to one of lesser severity. The mechanism by which the alteration could occur is similar to the one for the targets between 600 and 1300 feet.

#### Solution

The problem was solved by widening the altitude correlation acceptance gate so that the  $I_{+6}$  and  $I_{+13}$  responses are properly correlated with the target even if it has moved during the time interval between the  $I_{+13}$  and  $I_{+6}$  interrogations. In fact, the modification was to use the same acceptance gate width in the 9500 feet and below altitude regime as is used in the above 9500 feet altitude regime.

#### Discussion

The solution was successful for the remainder of the evaluation. However, since the majority of threats occur at closing rates under 250 knots, it appears that it would be more effective to keep the acceptance gate narrow for closing rates up to 300 knots and then widen it above that closing rate. In this way, improper correlation due to fruit and other target tracks would be minimized.

### FALSE ALARMS DUE TO CROSSTALK BETWEEN RECEIVING CHANNELS AT HIGH SIGNAL LEVELS

#### Problem

At signal strengths greater than 30 db above threshold, a received interrogation quad in one receiver channel crossed over into the second receiver channel, being delayed by approximately 100 ns. Thus, the first pulse pair in the direct channel could pair up with a second pulse pair of the crosstalk channel and cause improper altitude correlation; this would cause an alarm alteration.

For example, a target in the above 9500 ft regime which is 1300 ft above and is in Tau Zone One should result in a "limit climb rate to 500 fpm" (P5) display. However, the target could respond to the combination of the direct  $I_{-6}$  first pulse pair and the crosstalk delayed second pulse pair of the  $I_{-6}$  interrogation. This appears to the interrogator as though a single target has responded to both the  $I_{+6}$  and  $I_{-6}$  interrogations, overriding the correct P5 command. This results in either a climb or dive command depending on the interrogator's resolution of the apparent equal altitude threat.

Solution

The problem was solved by inhibiting the second channel for 160 ns after the first channel output was enabled, thus blocking out the crosstalk interrogation in the second channel as described in Appendix C. The solution was effective throughout the remainder of the flight tests.

Discussion

The solution was straightforward for the existing problem. In a receiver with high crosstalk rejection, the inhibit circuit would not be required.

MISSED ALARMS AND FALSE ALARMS CAUSED BY PULSE STRETCHING OF THE INTERROGATIONS

Problem

Under strong signal conditions, occasionally the first pulse of the first pulse pair of a received interrogation would merge with the second pulse of the first pulse pair, precluding decoding of the 400 ns spacing between the leading edge of the first and second pulses as shown in Figure V-3. This was caused by a combination of pulse stretching in the receiver on strong signal levels and to a lesser extent by the time uncertainties of the encode/decode circuits. When the decoding failed in a basic altitude band, a missed alarm ensued; when it failed in a branch altitude band, a false alarm ensued.

Solution

In order to prevent this condition, the spacing between the first and second pulses of the first pulse pair interrogation was changed from 400 ns to 500 ns and the spacing between the first and second pulses of the second pulse pair interrogation was changed from 500 ns to 600 ns. This provided adequate margin for an unobstructed leading edge on the second pulse of the first pulse pair under all signal conditions.

Discussion

No interrogation decoding problems were experienced after this modification was incorporated in the AVOID I CAS. Future equipments will have even greater margin due to improved receiver design in which the magnitude of the pulse stretching will be reduced.

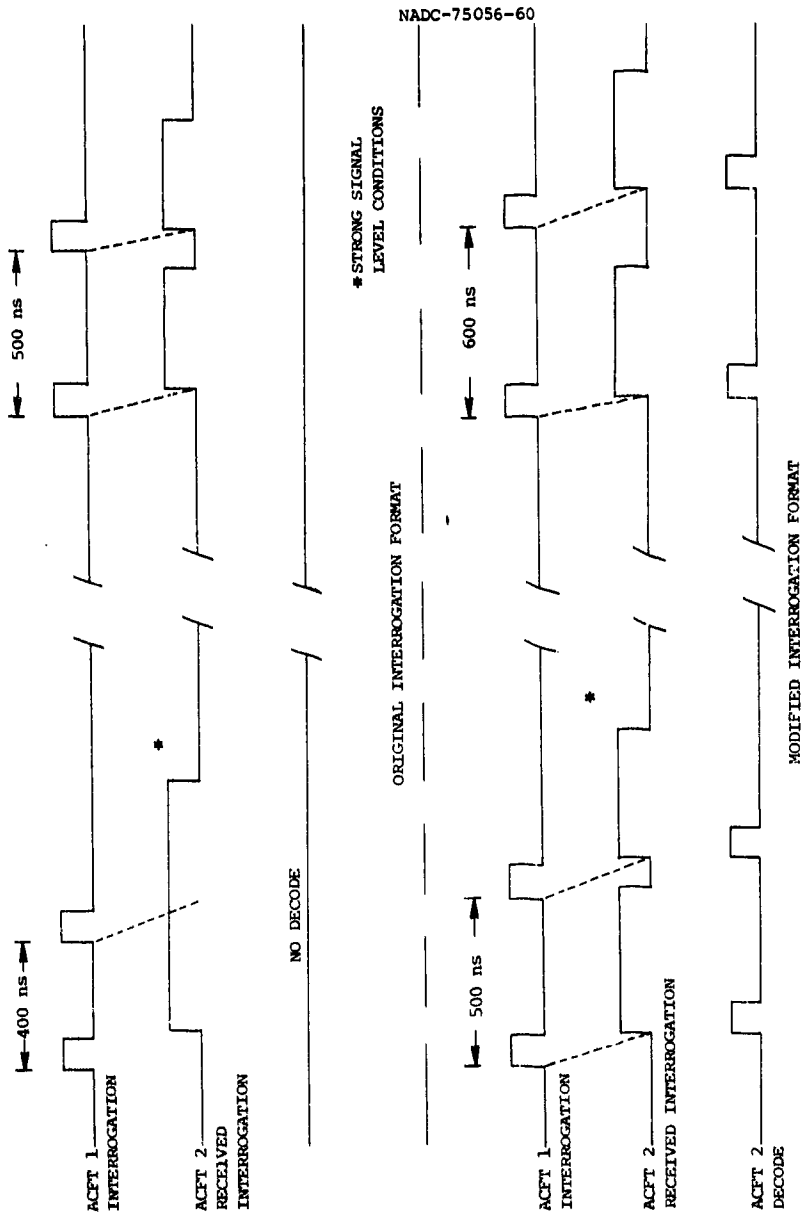

Figure V-3. Interrogation Format - Original and as Modified to Solve Pulse Stretching Problem.

## CHAPTER VI

## COMMUNICATION RANGE AND RELIABILITY

## INTRODUCTION

In order to assess efficiently the ability of the RF link between aircraft to provide ample warning time, NAVAIRDEVCEEN developed the single daisy versus figure eight flight profile, Figure VI-1. In the case of a two-aircraft encounter, the aircraft flying the daisy pattern commences flying from east of a TACAN ground station to west of the TACAN station. While inbound to the station from the east, his TACAN bearing is 270°, which is the course from magnetic north that he must fly to reach the station. After passing the TACAN station and continuing westward, his TACAN bearing is 90°. Upon reaching a predetermined distance west of the TACAN station, the pilot executes a 180° left turn to position the aircraft inbound on a radial displaced 15° from the previous radial traveled. His TACAN bearing is now 75°. After each traverse of the TACAN station, at the predetermined distance, the pilot executes a 180° left turn to assume a TACAN bearing displaced 15° from the previous one. This process continues for a total of 24 traverses of the TACAN station to form a daisy pattern. The aircraft flying the figure eight commences flying from west of the TACAN station to east of the station. While inbound to the station from the west, his TACAN bearing is 90°, which is the course he must fly to reach the TACAN station. After passing the TACAN station and continuing eastward, his TACAN bearing changes to 270°. Upon reaching a predetermined distance east of the station, the pilot executes a 180° left turn to position the aircraft inbound on a radial displaced 15° from the previous radial traveled. His TACAN bearing is now 255°. Following this course inbound, he traverses the TACAN station, whereupon his TACAN bearing changes to 75°. After reaching the predetermined distance outbound from the station, the pilot executes a 180° right turn and resumes his original eastward course with his TACAN reading 90°. Two traverses of the TACAN station constitute a figure eight. This pilot repeats the figure eight pattern until the other pilot has completed his daisy pattern. The result, with proper selection of aircraft velocities and predetermined starting and turning distances, is a series of 24 collision encounters, meeting directly over the TACAN station, but displaced by 500 to 1000 feet in altitude for safety of flight. The encounters occur in pairs, each pair being displaced 30° from the previous pair with head-on encounters considered to be 180° encounters and tail chases considered to be 0° encounters. The encounter angles, Figure VI-1, are the angles between the TACAN radials flown by the two aircraft. The convention chosen for positive and negative encounter angles was as follows:

NC-117 looks left to see RA-3B or P-3	(-)
NC-117 looks right to see RA-3B or P-3	(+)
RA-3B looks left to see P-3	(-)
RA-3B looks right to see P-3	(+)

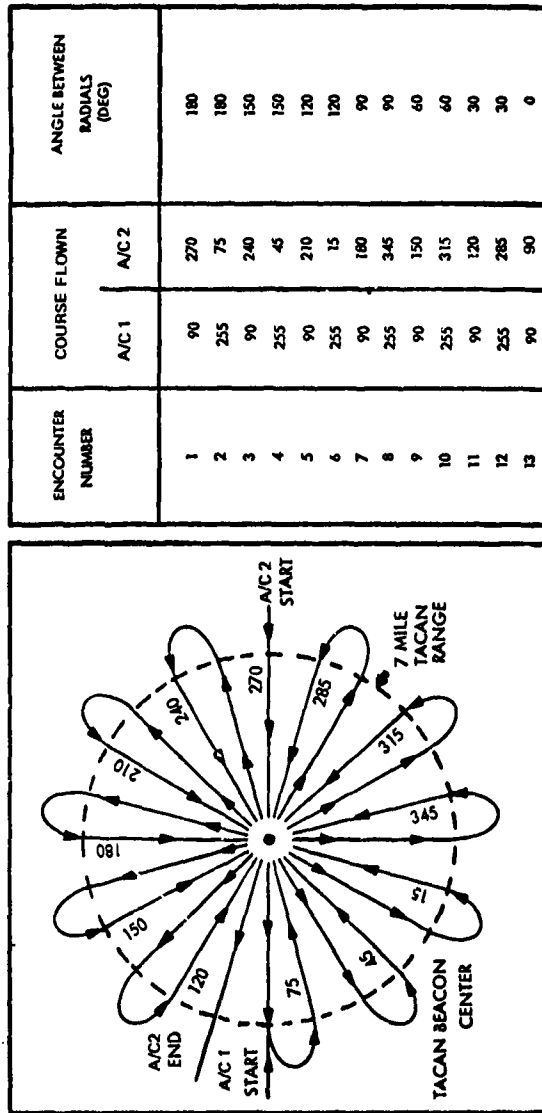

Figure VI-1. Communications Reliability Single Daisy Over a Figure Eight.

Thus, an encounter angle of  $-90^\circ$  involving the NC-117 and RA-3B means that the angle between TACAN radials flown is  $90^\circ$  and the pilot of the NC-117 would have to look to his left to see the RA-3B as they both approach the TACAN station.

The predetermined starting and turning distances were chosen as follows:

NC-117	-	7 nmi TACAN slant range
P-3	-	11 nmi TACAN slant range
RA-3B	-	13 nmi TACAN slant range

The true air speeds were chosen in the same ratios as their starting distances from the TACAN station, so that the aircraft would arrive over the TACAN station at the same time. Nominally, these true air speeds were 144 knots for the NC-117, 226 knots for the P-3, and 268 knots for the RA-3B. However, these speeds and turning distances were only approximations since adjustments had to be made for wind and other factors. In general, miss distances were on the order of 0.3 nmi or less for most of the collision encounters. For repeated high-speed, head-on encounters between the P-3 and RA-3B, as in flight 12, accomplished by each aircraft flying figure eights in opposite directions, the true airspeed was approximately 480 knots for the RA-3B and 320 knots for the P-3.

When three aircraft were simultaneously flown in collision encounters, two of the aircraft flew figure eight patterns displaced by  $90^\circ$  in space, while the third aircraft (the P-3) flew a daisy pattern. Thus, the P-3 aircraft generated a  $360^\circ$  daisy pattern with each of the other two aircraft, while they flew repeated  $90^\circ$  encounters with each other.

With the geometry of flight chosen for optimum (minimum flight time) determination of communication range in encounter angle steps of 3 degrees, certain geometry limitations had to be tolerated. For example, in the tail chase of the P-3 at 11 nautical miles by the RA-3B at 13 nautical miles, the maximum measurable communication range would be 2 miles, with corresponding but less severe limitations at other encounter angles. For the most part, this problem was solved by using 6 db of attenuation in the RF link between the aircraft involved in an encounter. This had the effect of doubling the geometric limits as far as the important parameter of signal strength was concerned. Thus, the geometric limit for a tail chase between the P-3 and RA-3B was increased to 4 nautical miles with the 6 db attenuator. However, since even 4 miles is not sufficient for some tail chase encounters, a separate flight test number 12 was flown without the daisy pattern limitations in geometry for the RA-3B versus the P-3. In the case of the P-3 versus the NC-117, the geometric limitation of 4 miles increased to 8 miles with 6 db of added attenuation and to 11 miles with 9 db of attenuation. This was sufficient not to warrant a separate tail chase flight.

Typical geometric limitations for some of the communication range flights are plotted in Figures VI-2 and VI-3 for the NC-117 versus the P-3, and the RA-3B versus the P-3, respectively. These can be used as a convenient guide to determine whether the communication ranges for the various flights fall within the expected geometric limitations. One would not expect the communication range to exceed the theoretical geometric limitations, although occasionally this did occur for small encounter angles, because of imperfections in the flight course flown, due primarily to wind and one pilot turning sooner or later to correct for a previous encounter with a large miss distance. Where the communication range was limited by geometry or aircraft turning to get on course, the range was noted as being greater than the recorded amount. Otherwise, the ranges are considered representative of the communication ranges to be expected for the given encounter angles. Generally, in each flight there were two ranges for each encounter angle. These differed in some case by as much as two to one, due to the different crab angles required to fly the given TACAN radials going in opposite directions. While all points are plotted, the communication range curves are drawn through the approximate mean of the available data points for each encounter angle, on each flight.

The communication ranges shown in the graphs to follow are all in terms of the earliest reliable range and range rate track of one aircraft by the other. It must be remembered that the AVOID I system tested completes a 3-second track sequence consisting of 7 interrogation sets only when a threat exists. This reduces the average interrogation rate, and hence reduces fruit. For the aircraft used in this flight evaluation, the closing rates were generally less than 500 knots, for which the threat ranges were less than 7.4 nautical miles. To achieve range and range rate tracking printouts beyond the threat range, a special test mode of operation was added. This mode, called the "unrestricted interrogation" mode, as opposed to the "normal" mode, permitted the AVOID I equipment to complete a 3-second sequence for any target aircraft, whether or not it was a threat. With this mode of operation, plus the addition of varying amounts of external RF signal attenuation, the communication range limits of the system could be established. With rare exceptions, the reliable communication range recorded was that at which round reliability before the TAU-2 warning threshold was reached exceeded 90%. In the subsequent section dealing with round reliability, these rounds are called the "Before TAU-2" rounds. The criterion used for communication range was variable, in that there were instances in which several successful rounds in a row were achieved, followed by gaps of several unsuccessful rounds, followed in turn by a more consistent successful sequence of rounds before TAU-2. The lower communication range representing the start of the more consistent sequence of rounds was generally used. In all cases, the "Before TAU-2" round reliability corresponding to the communication range used was recorded. The maximum communication range required is 15.1 nautical miles for a head-on encounter of two aircraft above 10,000 feet, flying at 600 knots each. The communication range required decreases to 6.8 nautical miles for a tail chase of a 150-knot aircraft by a 600-knot aircraft above 10,000 feet.

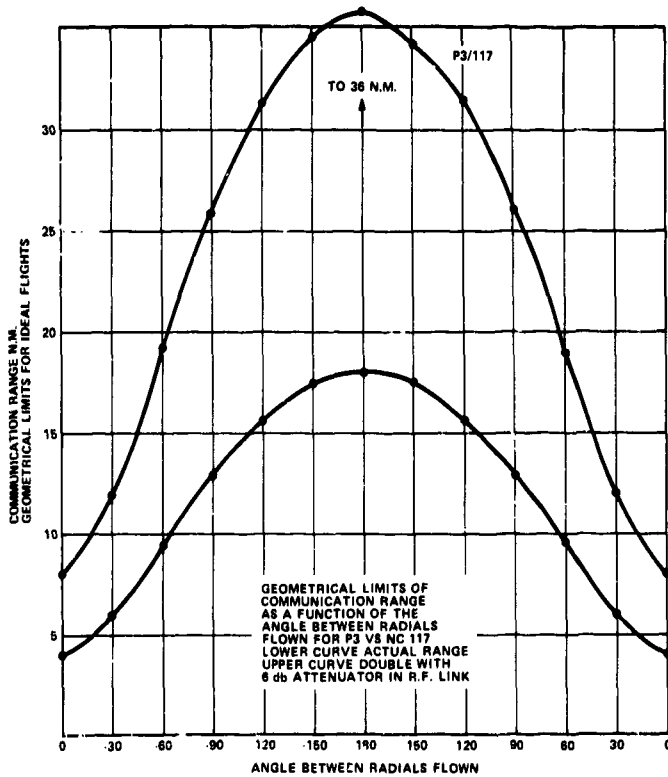

Figure VI-2. Geometric Limitations, NC-117 Versus P-3A.

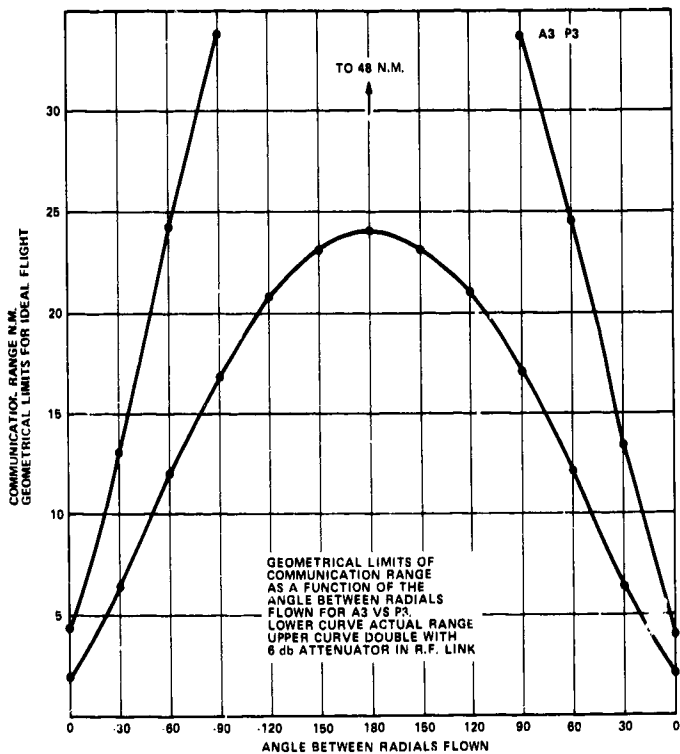

Figure VI-3. Geometric Limitations, RA-3B Versus P-3A.

The communication range tests were run with levels of fruit ranging up to approximately 64,000 single pulse replies per second above threshold in one of the two receivers. The AVOID I uses a separate receiver for each antenna and merges the detected video reply signals into a common set of range bins. Introducing all of the fruit replies in one receiver is therefore a more severe test of traffic handling capability than dividing the fruit equally between the two receivers. In addition, up to 1,536 interrogation pulse quads (6,144 single pulses) per second above threshold were added to the same receiver receiving the fruit replies. Of these, 20% were altitude coded by the spacing of the second pulse pair with respect to the first pulse pair, to require a response. Regardless of whether a response was required, the first pulse pair of each interrogation quad placed the AVOID I under test in the response mode. It therefore contributed to the blocking time when the AVOID was unavailable to respond to the real target aircraft, thus effectively simulating real world traffic. A second decoder is activated after 16  $\mu$ sec of multipath protection to reduce the blocking. These above-threshold fruit replies and interrogation quads were counted in the AVOID receiver and recorded on tape. There was no noticeable reduction in the communication range or reliability when these levels of fruit were used at both ends of the RF link. However, false alarms due to correlation of fruit replies in the seven successive interrogation sets of a 3-second sequence did occasionally occur at the 64,000 level of fruit replies. Most of these were correlations taking place in the more distant range bins at supersonic range rates. This type of false alarm could have been eliminated since there was no requirement to test the supersonic capability. Also, while the number of one-round fruit correlations taking place was significant, the display threat criteria of two rounds out of three for targets within 1300 feet of altitude kept the displayed false alarm rate to a low value.

Six flights, namely 4, 6, 7, 9, 11, and 12 were utilized for communication range data, of which flights 9 and 11 involved three aircraft. For communication range purposes, the three aircraft flights were each equivalent to three flights involving two aircraft. Since a single two-aircraft flight yields two sets of communication range data, one for each aircraft, there were 20 sets of data available involving 168 collision encounter pairs. Stated briefly, there was sufficient communication range at all collision encounter angles flown to ensure the required TAU TWO warning times with varying power margins for the speeds flown. Extrapolation to the maximum 1200-knot closing rate above 10,000 feet still yielded sufficient communication range with adequate power margins for all encounters except a few head-on encounters between the P-3 and A-3. It must be emphasized, however, that the extrapolation process has two major flaws. First, aircraft capable of the higher speeds would have different antenna pattern configurations. Second, the flight geometry would be different for the same encounter angle. For example, a 90° encounter between a 150-knot aircraft and a 300-knot aircraft would involve an antenna look angle for the 300-knot aircraft of  $\arctan 1/2$  or 26.6°. The look angle for the 150-knot aircraft would be 63.4°. This can readily be extrapolated to a 90° encounter between a 300-knot aircraft and a 600-knot aircraft with the same look angles

and twice the required communication range. However, one cannot readily extrapolate to a 90° encounter involving two 600-knot aircraft where the antenna look angle would be 45° for both aircraft. In short, encounter angles are not the same as antenna look angles. From a practical point of view, however, the critical encounter angles are the 180° (head on) and the 0° (tail chase) for which extrapolation to higher speed aircraft would be geometrically valid. Also, normal wind variations result in a variety of antenna look angles for each encounter angle.

Figures VI-4 and VI-5 show the variation in antenna look angle as a function of the angle between radials flown for various aircraft speed ratios. In the case of the A-3 versus the P-3, the 1.2 speed ratio was the one most often used. The figures can, however, be used for other speed ratios involving the slower speed NC-117.

#### COMMUNICATION RANGE - P-3 VERSUS RA-3B FLIGHTS

It is instructive to examine each of the individual flights in detail. This section deals with flights involving the P-3 and A-3 aircraft. Figure VI-6, flight 4, is a plot of communication range versus the angle between radials flown for the P-3 above the A-3 with 1100 feet altitude separation. The P-3 altitude was 11,000 feet, while the A-3 altitude was 9,900 feet. The fruit injected into the P-3 was 32000/1536. This notation will be used throughout the report with the first number indicating the fruit replies per second above threshold and the second number indicating the number of interrogation quads per second above threshold. In accordance with this notation, the A-3 fruit was 64000/1536. The solid line drawn as the mean of the available data points (usually two per encounter angle) represents the range at which reliable P-3 tracking of the A-3 commenced. The dashed line represents the range at which reliable A-3 tracking of the P-3 commenced. The A-3 data was available only for the -30, -60, and -90 degree encounters, because the AVOID I in the A-3 was operated in the unrestricted mode of interrogation only for those encounters. The use of the unrestricted mode with 64,000 fruit replies obscured the ability of the instrumentation to read the target range and range rate consistently, but had no adverse effect on the operation of the AVOID I system itself. This was because the two-target range and range rate instrumentation read-out capability was often tied up displaying non-threatening fruit tracks, which would not have been present in the normal mode of operation. At lower fruit rates, this instrumentation difficulty was not experienced. In the P-3, the project crew was able to switch from unrestricted interrogations at the maximum communication range to normal interrogations just before the expected start of the TAU-2 warnings. Since no external RF attenuation was used on this flight, the communication range at the lower encounter angles were limited by the flight geometry and are therefore marked as being greater than the values shown. The dip in the communication range at -120 degrees is unexplained. Nevertheless, for the speeds flown at an indicated closing range rate of 420 knots, the required communication range is only 6.5 miles for which the mean communication range of 13.1 miles represents a margin of 6 db. At the maximum

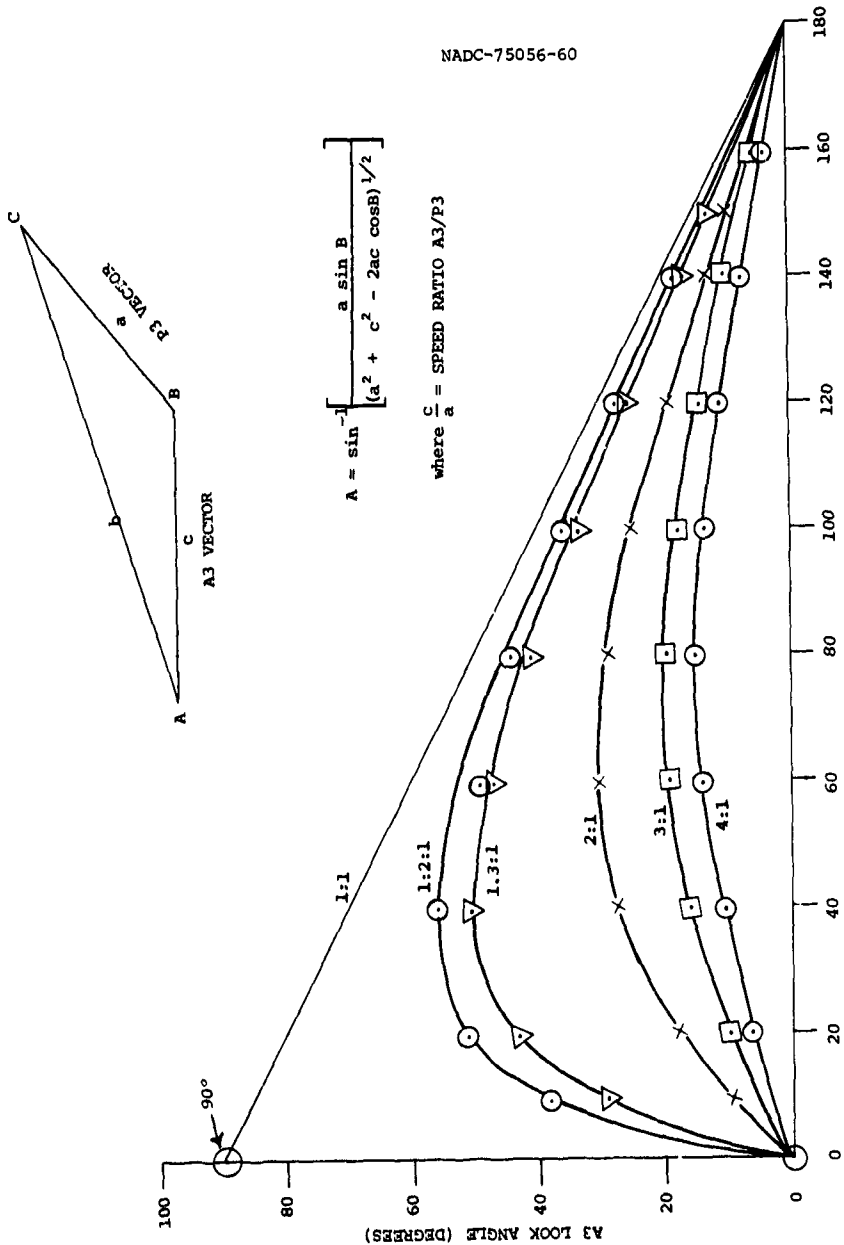

ENCLOSED ANGLE BETWEEN A3 & P3 (DEGREES)  
 Figure VI-4. RA-3B Antenna Look Angle Versus Angle Between Radials Flown.

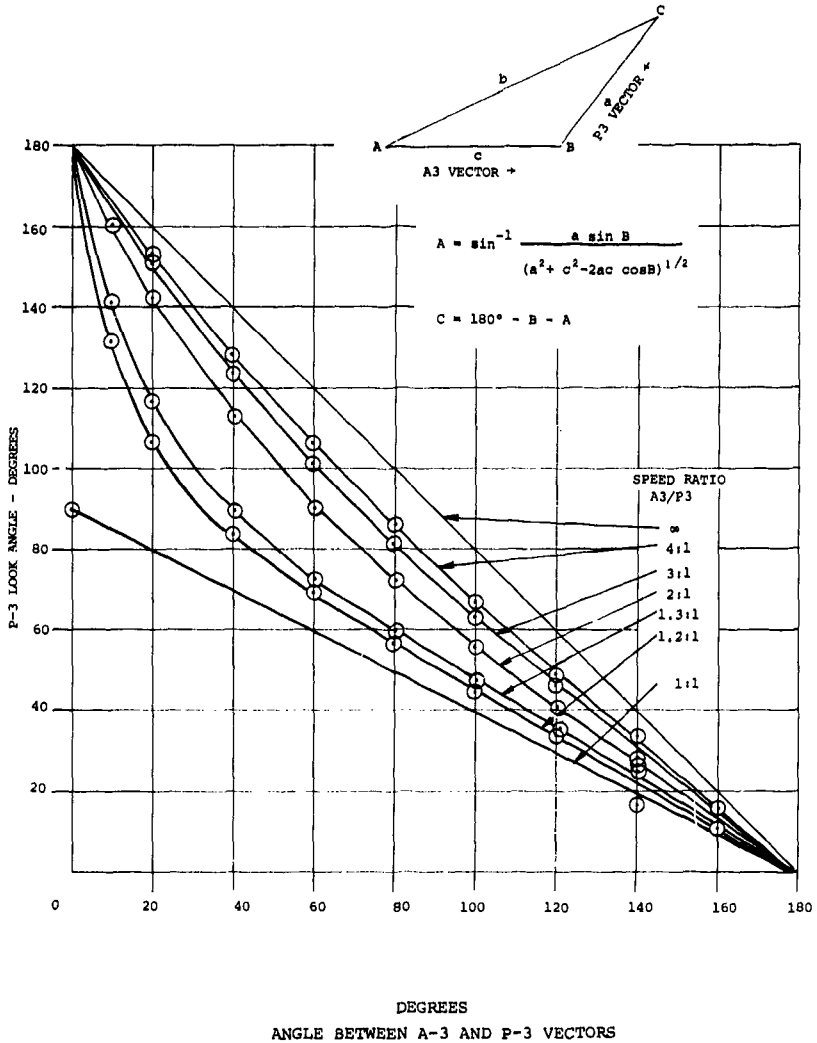

Figure VI-5. P-3A Antenna Look Angle Versus Angle Between Radials Flown.

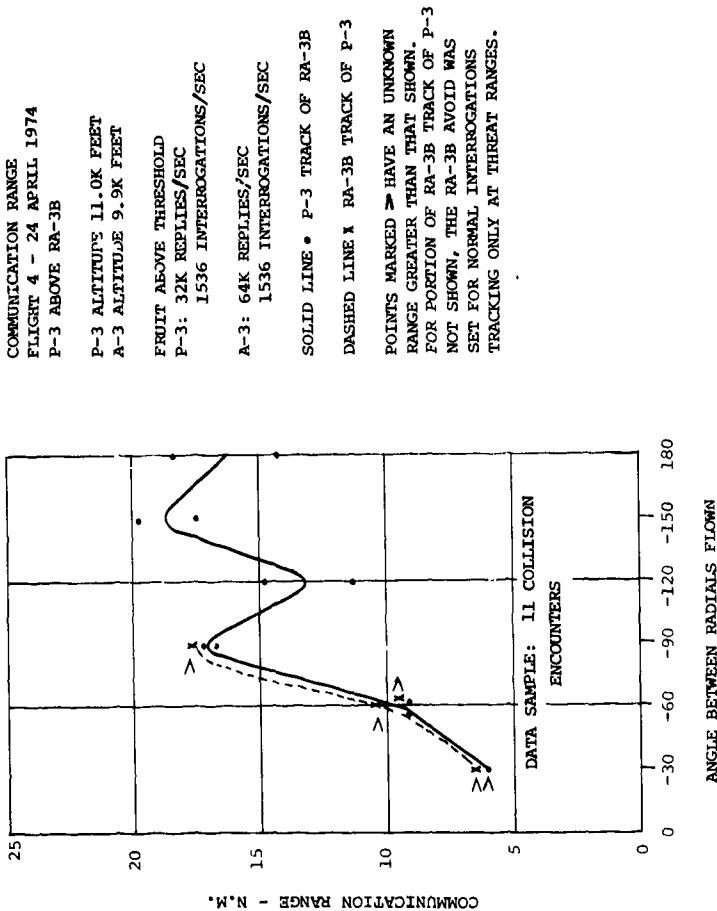

Figure VI-6. Communication Range, Flight 4, P-3A Above RA-3B.

speed of 600 knots each, the communication range required for an encounter angle of  $-120^\circ$  is 13.3 miles, for which the mean range of 13.1 miles is barely adequate. However, using the same speed ratio as that actually flown (approximately 1.2) and increasing the speed of the faster aircraft to 600 knots, the slower aircraft would have to fly at 500 knots to preserve the same antenna look angles. The closing range rate would then be 954 knots, for which a communication range of 12.4 miles is required. Using the same look angle as a criterion rather than the angle between radials flown, the extrapolated communication range margin would be 0.6 db. The head-on mean communication range of 16.3 miles compared to a required 7.4 miles at the indicated closing range rate of 500 knots represents a margin of 6.9 db. When extrapolated to a 1200-knot head-on encounter, the margin is 0.7 db assuming a required 15.1 mile range, and only 0.1 db assuming a required 16.1 miles to allow an extra mile for the two out of three AVOID I warning display criteria.

The only other head-on encounter data available with the P-3 above the A-3 is that shown in the right-hand portion of Figure VI-7. This was a portion of flight 12 on 29 July 1974, with the P-3 at 11,800 feet and the A-3 at 11,100 feet. The A-3 had no fruit, while the P-3 fruit was 32,000/1536 as before. The P-3 tracking of the A-3 commenced at 16.4 nautical miles, while the A-3 commenced tracking of the P-3 at 12.9 nautical miles, again indicating adequate communication range for the speeds flown, but marginal range when extrapolated to a head-on encounter between two 600-knot aircraft. The case of the A-3 flying above the P-3 (the left-hand portion of Figure VI-7) will be discussed later. A histogram of the head-on communication range with the P-3 above the A-3 is shown in Figure VI-8. The data base consisting of only three collision encounters is limited. It indicates a range from a low of 12.9 nautical miles to a high of 18.4 nautical miles with a mean of 15.5 nautical miles, which is an adequate but marginal communication range for extrapolated 1200-knot head-on encounters. Careful attention to antenna placement could alleviate this problem.

The only other communication range data for the case of the P-3 flying above the A-3 are the tail chase encounters of Figure VI-9 for another portion of flight 12. To partially offset geometry limitations, 3 db of external RF attenuation was used. The left-hand portion of the graph is for the A-3 tail chase of the P-3 from 800 feet below. The solid line indicates the P-3 was able to track the A-3 in one case from a range greater than 7.3 miles, and in the other case from a range of 13.5 miles. Correspondingly, the dashed line indicates that the A-3 was able to track the P-3 in one case from a range greater than 7.4 miles, and in the other case from a range of 12.9 miles. The data corresponding to the right-hand portion of the graph was taken in a tail chase configuration with the A-3 opening from the P-3 and 900 feet below it. This is equivalent to a P-3 tail chase of the A-3. The solid line indicates communication ranges for the P-3 track of the A-3 greater than 10.3 and greater than 7.1 miles, while the corresponding values for the A-3 track of the P-3 were 10.7 miles and greater than 7.1 miles. This data indicates the tail chase communication range was adequate for extrapolated worst case conditions.

COMMUNICATION RANGE  
HEAD-ON ENCOUNTERS (180 DEG)  
FLIGHT 12 JULY 29, 1974

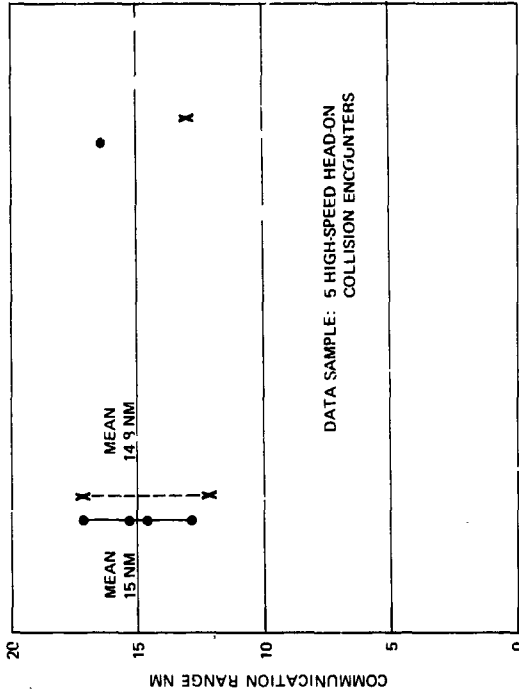

RA3B 11.8K FEET } A3 ABOVE  
P3 11.1K FEET }

P3 11.8K FEET } P3 ABOVE  
RA3B 11.1K FEET }

DATA POINTS FOR A3 ABOVE  
P3 INCLUDE CORRECTION FOR  
2 db LOSS IN TOP FIELD P3  
RECEIVER SENSITIVITY.

FRUIT ABOVE THRESHOLD  
P3 32K REPLIES/SEC  
1536 INT/SEC  
A3 NONE

P3 A3  
180 DEG  
HEAD-ON 850 KNOT  
ENCOUNTERS  
A3 ABOVE P3

P3 A3  
180 DEG  
HEAD-ON 850 KNOT  
ENCOUNTER  
P3 ABOVE A3

Figure VI-7. Communication Range, Flight 12, P-3A Versus RA-3B, Head-On Encounter.

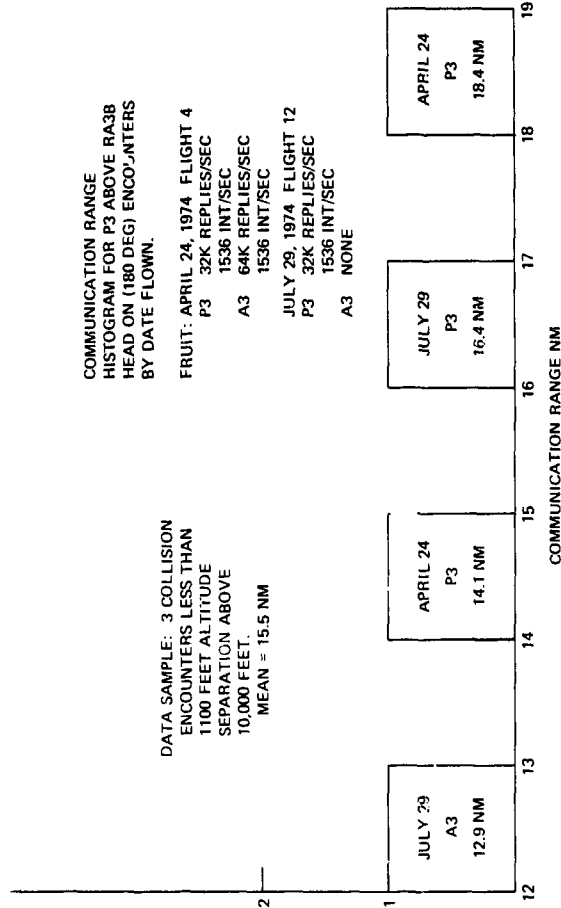

Figure VI-8. Communication Range Histogram for P-3A Above RA-3B.

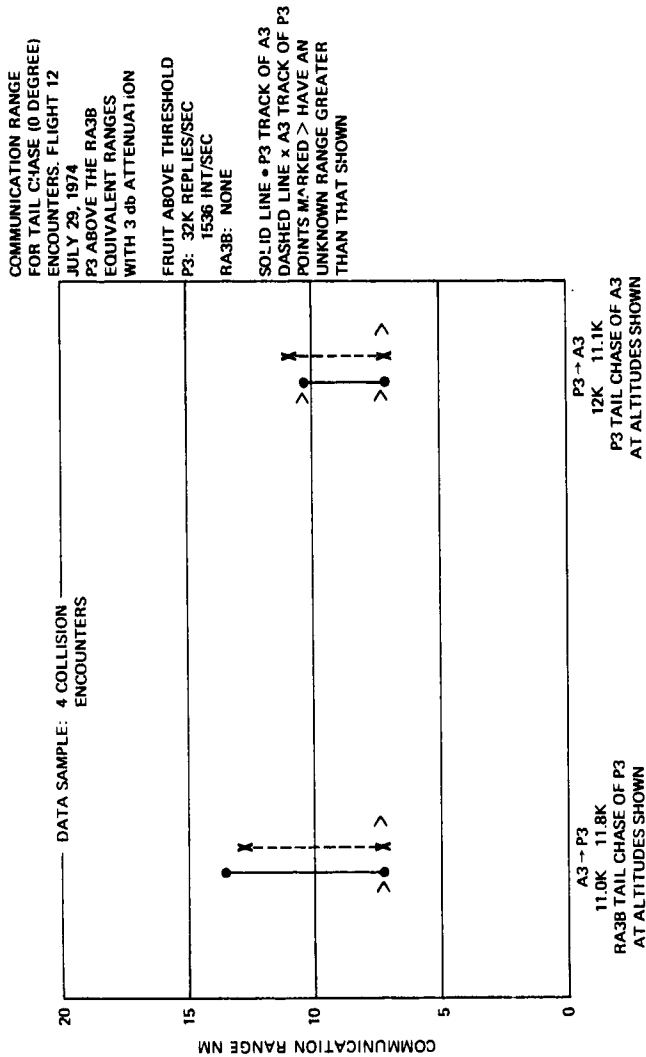

Figure VI-9. Communication Range, Flight 12, P-3A Above RA-3B, Tail Chase Encounters

Using the 10.7 mile range compared to a maximum required tail chase range of 6.8 miles, the margin was 4 db.

More extensive data was available for the case of the A-3 flying above the P-3. Figure VI-10 shows the communication range versus angle between radials flown for flight 9 of 17 July, with the A-3 at 11,000 feet and the P-3 at 10,500 feet. This was a three-aircraft encounter in which the required evasive actions were taken by the A-3 above and the NC-117 below, with the P-3 flying level in the middle. The fruit at each end of the link in both the A-3 and P-3 was 32,000/1536. External attenuation of 6 db was used to find the limits of the communication range. Once more, the solid line represents the earliest reliable communication range of the P-3 tracking the A-3, while the dashed line provides the same information for the A-3 tracking the P-3. The data sample involved 26 collision encounters covering a complete daisy pattern every 30 degrees. It can be seen that the required range was achieved at all encounter angles both at the speeds flown and for extrapolated worst case conditions. For example, the P-3 mean communication range for the head-on encounters was 18.7 miles, which represents a margin of 1.9 db using 15.1 miles as the required range, and 1.3 db using 16.1 miles as the required range. The A-3 mean communication range for the same head-on encounters was 21.5 miles to give margins of 3.1 db or 2.5 db respectively. The tail chase range of 10 miles compared to a worst case requirement of 6.8 miles gave a margin of 3.4 db. The margins at most of the other encounter angles were greater than those for the tail chase and head-on encounters. The left-hand portion of the graph of Figure VI-7 (flight 12) has some additional head-on encounter data for the A-3 above the P-3. The A-3 flew at 11,800 feet, while the P-3 flew at 11,100 feet. These were four high-speed encounters in the range of 800 to 900 knots without external attenuation. However, there was a known malfunction resulting in a loss of at least 2 db receiver sensitivity in the top field of the serial 1 Avoids equipment installed in the P-3. Since this would ordinarily be the preferred receiver field, its lower sensitivity could have induced replies from the P-3 to be transmitted out of the bottom or non-preferred antenna, thus reducing the communication range. For that reason, a conservative compensation of 2 db was incorporated in the plotted results with a resultant mean communication range of 15 nautical miles for the P-3 track of the A-3 and a mean communication range of 14.8 nautical miles for the A-3 track of the P-3.

Figure VI-11 (flight 11) has some additional communication range data for the second three aircraft encounter of 26 July 1974. The data here was limited to the smaller encounter angles between -90 and +60 degrees. The solid line once more represents the P-3 track of the A-3, and the dashed line represents the A-3 track of the P-3. The required communication range was met and exceeded both for the speeds flown and for maximum extrapolated speeds. For example, the maximum requirement for two 600-knot aircraft at an encounter angle of -90 degrees is 11.2 miles. The mean P-3 communication range for this encounter angle was 14.7 miles, giving a margin

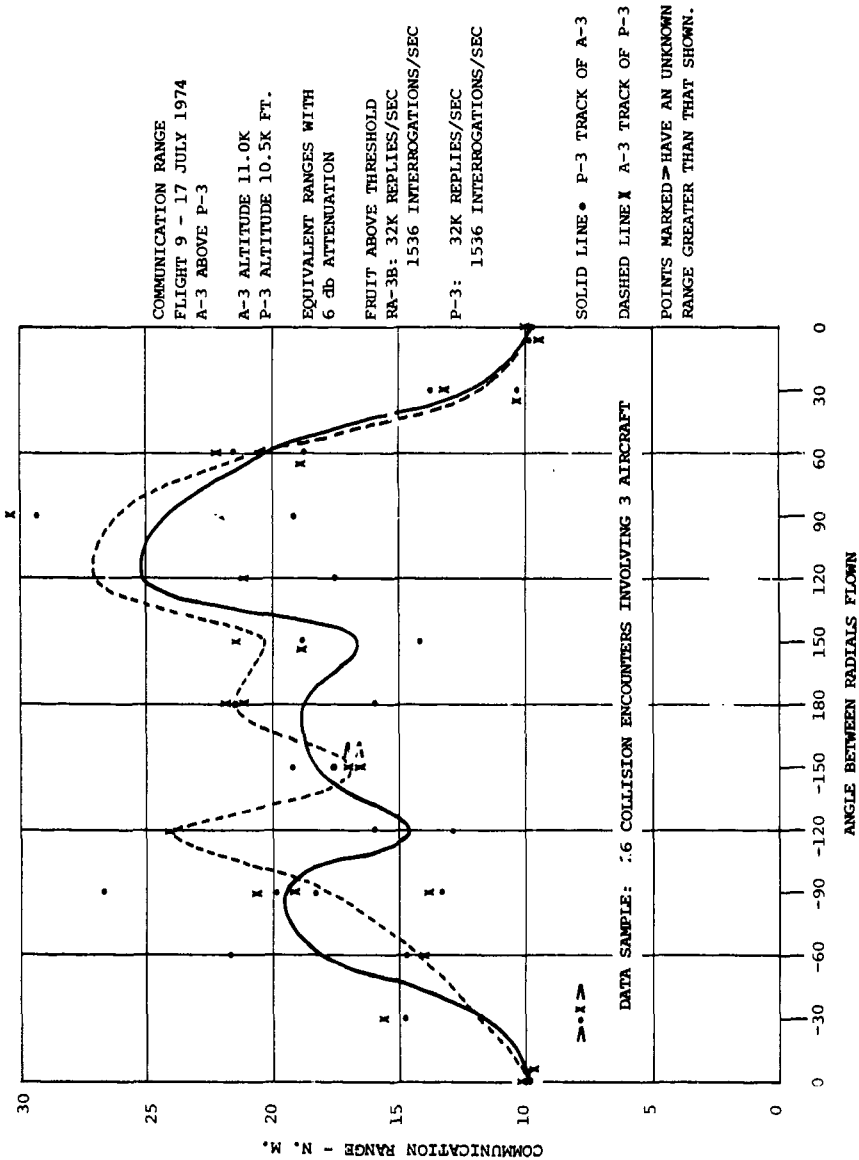
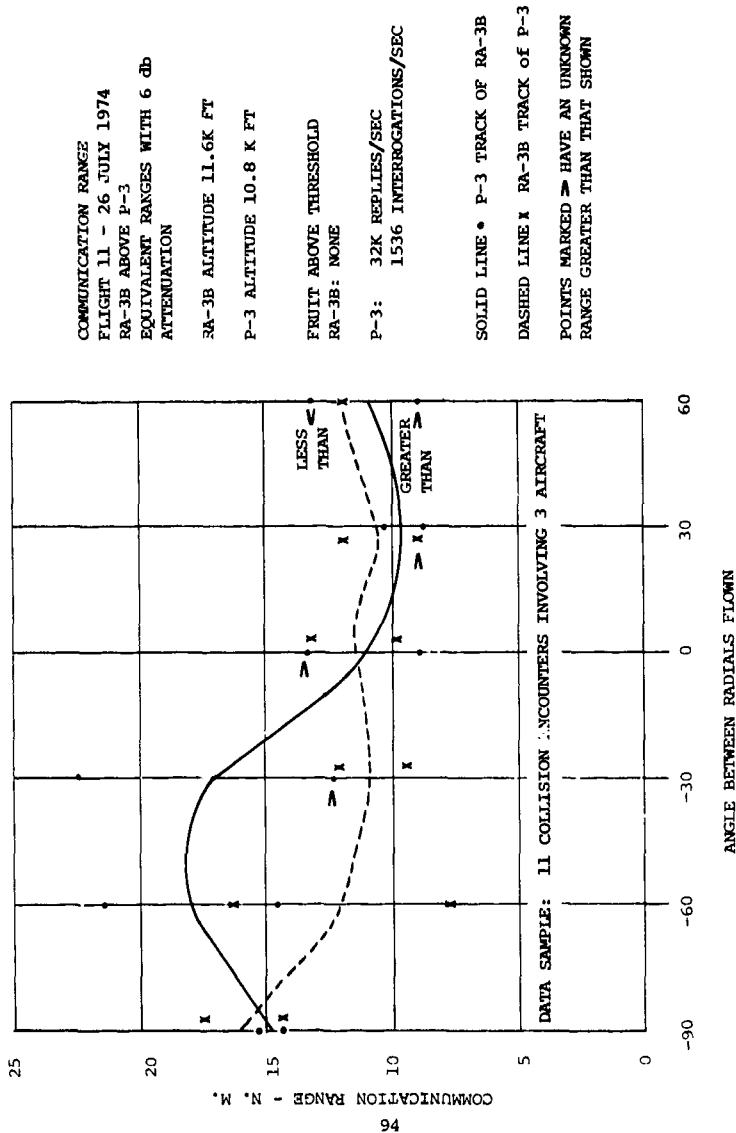

Figure VI-10. Communication Range, Flight 9, RA-3B Above P-3A.



COMMUNICATION RANGE  
 FLIGHT 11 - 26 JULY 1974  
 RA-3B ABOVE P-3  
 EQUIVALENT RANGES WITH 6 db  
 ATTENUATION

RA-3B ALTITUDE 11.6K FT  
 P-3 ALTITUDE 10.8 K FT

FRUIT ABOVE THRESHOLD  
 RA-3B: NONE

P-3: 32K REPLIES/SEC  
 1536 INTERROGATIONS/SEC

SOLID LINE • P-3 TRACK OF RA-3B  
 DASHED LINE X RA-3B TRACK OF P-3

POINTS MARKED => HAVE AN UNKNOWN  
 RANGE GREATER THAN THAT SHOWN

Figure VI-11. Communication Range, Flight 11, RA-3B Above P-3A.

of 2.4 db. The P-3 margin for the 0 degree tail chase (11 miles compared to a maximum required of 6.8 miles) was 4.2 db. This flight was made in a manner similar to flight 9 with 6 db of external RF attenuation. The A-3 altitude was 11,600 feet, while the P-3 altitude was 10,800. There was no fruit in the A-3, while the fruit in the P-3 was 32,000/1,536. The results of flight 11 were in general agreement with the results of the corresponding portions of flight 9.

A communication range histogram for the head-on encounters involving the A-3 above the P-3 summarizing the previous A-3 above P-3 head-on data is shown in figure VI-12. The mean of 6 collision encounters involving 10 data points was 17 miles for a margin of 1 db or 0.5 db, depending on the choice of 15.1 or 16.1 miles for the required extrapolated 1200-knot range. The extremes ranged from 12.3 miles to 21.8 miles.

Figure VI-13 combines and summarizes the available communication range data of flights 4 and 12 for the P-3 flying above the A-3. The graph is drawn through the means of the available 25 data points from 16 collision encounters, of which 16 were from the P-3 and 9 were from the A-3. The curve indicates that on the average the required communication range for extrapolated worst case conditions was met or exceeded, with the marginal encounter angles being -120 and 180 degrees.

Figure VI-14 similarly combines and summarizes the available communication range data of flights 9, 11, and 12 for the A-3 flying above the P-3. The graph is drawn through the means of the available 77 data points from 41 collision encounters, of which 41 were from the P-3 and 36 were from the A-3. The curve indicates that on the average the required communication range for extrapolated worst case conditions were exceeded for all encounter angles flown with a pronounced peak at plus 120 degrees.

#### COMMUNICATION RANGE - P-3 VERSUS NC-117 FLIGHTS

This section discusses the results of the Communication Range flights involving the P-3 and the NC-117 aircraft. Briefly, the required communication range was exceeded both for the speeds flown and for extrapolated highest permissible speeds at all encounter angles.

Figure VI-15 gives the communication range as a function of the angle between radials, with the P-3 above the NC-117, for flight 6 of 1 July 1974. No external RF attenuation was used; consequently, the range although adequate was limited by the geometric pattern of the flight. There was excellent correspondence between the P-3 track of the NC-117 shown by the solid line and the NC-117 track of the P-3 shown by the dashed line. Both, in turn, corresponded to the geometric limitations of the lower curve of figure VI-2. The P-3 flew at 11,000 feet which was 1000 feet above the NC-117 at 10,000 feet. Each aircraft has 1536 interrogation quads per second injected on an RF basis by the traffic simulator, with the P-3 having 32,000 fruit replies

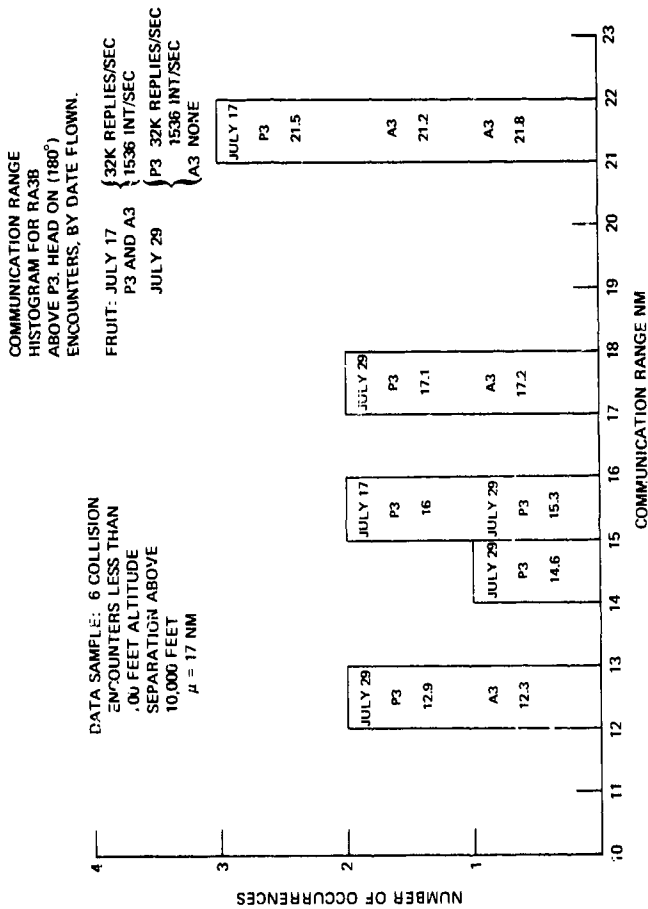
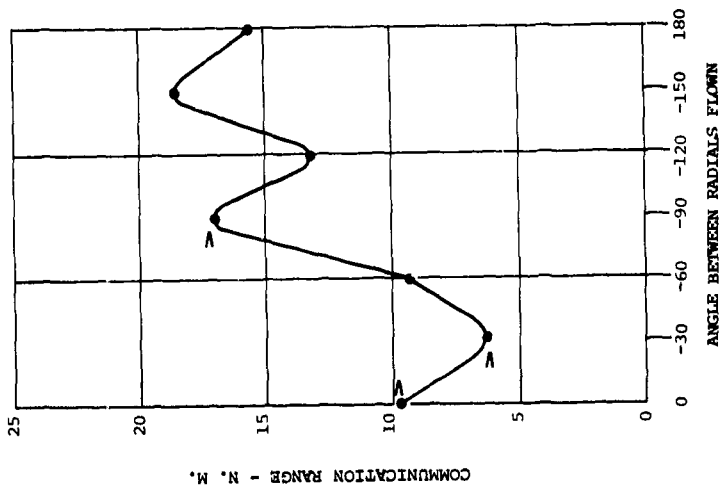

Figure VI-12. Communication Range Histogram for RA-3B Above P-3A for Head-On Encounters.



MEAN COMMUNICATION RANGE AS A FUNCTION OF THE ANGLE BETWEEN RADIALS.  
 FLIGHTS 4 AND 12 - 24 APRIL AND 29 JULY 1974.  
 P-3 700 TO 1100 FT ABOVE RA-3B  
 BOTH ABOVE 10,000 FEET.  
 RANGE AT 0 DEGREES IS EQUIVALENT RANGE FOR 3 db OF ATTENUATION IN RF LINK.

POINTS MARKED  $\Rightarrow$  HAVE AN UNKNOWN RANGE GREATER THAN THAT SHOWN

DATA SAMPLE: 16 COLLISION ENCOUNTERS  
 25 DATA POINTS  
 (16 FROM P-3, 9 FROM A-3)

Figure VI-13. Communication Range, Flights 4 and 12, P-3A Above RA-3B.

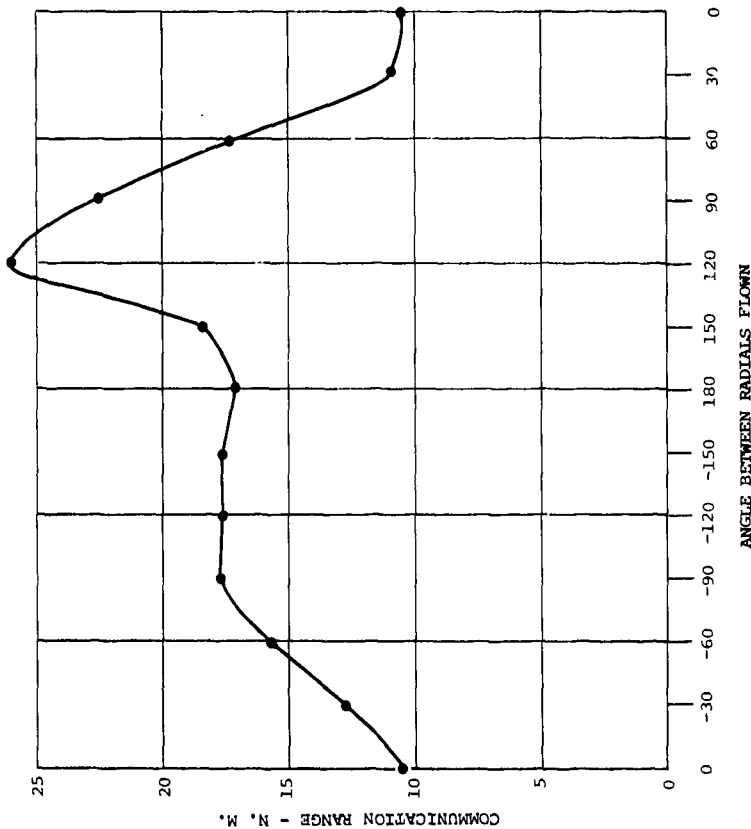

MEAN COMMUNICATION RANGE AS A FUNCTION OF THE ANGLE BETWEEN RADIALS FLOWN.

FLIGHTS 9, 11 & 12 - 17, 26 & 29 JULY 1974.

FLIGHTS 9 AND 11 SHOW EQUIVALENT RANGE WITH 6 db ATTENUATION IN RF LINK.

FLIGHT 12 INCLUDES CORRECTION FOR 2 db LOSS IN TOP FIELD P-3 RECEIVER SENSITIVITY.

A-3 500 TO 800 FEET ABOVE P-3, BOTH ABOVE 10,000 FEET.

DATA SAMPLE: 41 COLLISION ENCOUNTERS.

77 DATA POINTS

(41 FROM P-3,

36 FROM A-3)

Figure VI-14. Communication Range, Flights 9, 11, and 12, RA-3B Above P-3A.

COMMUNICATION RANGE AS A FUNCTION OF THE ANGLE BETWEEN RADIALS. FLIGHT 6, 1 JULY 1974.  
 NO ATTENUATION. RANGE LIMITED BY GEOMETRIC PATTERN OF FLIGHT.  
 ACTUAL COMMUNICATION RANGE IS GREATER THAN THAT SHOWN.

P-3 ABOVE NC-117 LEVEL FLIGHT

P-3 ALTITUDE 11K FEET

NC-117 ALTITUDE 10K FEET

FRUIT: P-3 32K REPLIES/SEC  
 1536 INTERROGATIONS/SEC

NC-117 64K REPLIES/SEC  
 1536 INTERROGATIONS/SEC

SOLID LINE • P-3 TRACK OF NC-117

DASHED LINE ■ NC-117 TRACK OF P-3

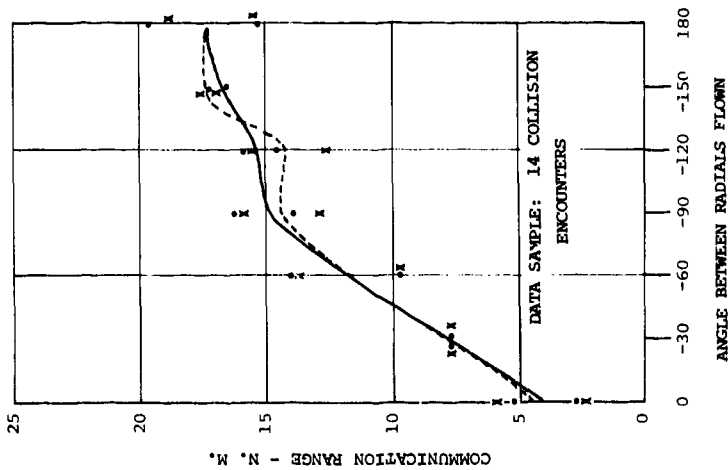

Figure VI-15. Communication Range, Flight 6, P-3A Above NC-117.

per second compared to 64,000 fruit replies per second in the NC-117. The curves are drawn through the mean communication range of each encounter angle based on the data available from 14 collision encounters.

Figure VI-16 gives the communication range as a function of the angle between radials flown for flight 7 of 3 July 1974. The fruit reply rate was raised to 64,000 per second in both aircraft, and 6 db of external attenuation was added to the RF link. Climb and dive commands were obeyed with the P-3 commencing at 10,500 feet, climbing to 11,000 feet, and the NC-117 commencing at 10,000 feet and diving to 9600 feet. These maneuvers, of course, did not affect the initial communication ranges plotted. The doubled ranges equivalent to the use of 6 db attenuation are shown with the solid curve once more being the mean range at which the P-3 commenced reliable tracking of the NC-117 and the dashed curve being the mean range at which the NC-117 commenced reliable tracking of the P-3. In spite of the use of 6 db attenuation, maximum ranges were still generally limited by the geometric pattern of flight. Although the mean ranges obtained obviously had a greater than 6 db margin for most extrapolated high-speed encounter angles, the limits of the communication range were not reached until flights 9 and 11 were flown with 9 db of external attenuation. The circled point at an angle of 90° illustrates a difficulty occasionally encountered in deciding on the reliable communication range. Earlier bursts of reliable communication were achieved for this encounter at greater ranges, but continued consistent reliability until the TAU 2 threshold was reached, was not achieved until the 12.2-mile range shown. In making comparisons with the results of flight 6, it must be remembered that this flight covered positive encounter angles (NC-117 looks to its right to see the P-3), whereas flight 6 covered negative encounter angles (NC-117 looks to its left to see the P-3). However, allowing for the extra 6 db of attenuation of flight 7 and the geometrical limitations, good symmetry is indicated. The encounter angle reversal was accomplished by interchanging the patterns flown, with the NC-117 flying the daisy pattern starting east of the TACAN station and the P-3 flying the repeated figure eight pattern starting from west of the TACAN station.

Figure VI-17 shows the communication ranges as a function of the angle between radials for the second half of the daisy pattern of flight 7 on 3 July 1974, with the encounter angles now being negative. For this portion of the flight, both aircraft flew below 10,000 feet, with the NC-117 at 9,500 feet, 500 feet above the P-3 at 9,000 feet. These were initial altitudes with evasive climb and dive maneuvers carrying the NC-117 to 10,000 feet and the P-3 to 8,600 feet. The same 64000/1536 fruit rates and 6 db of attenuation were retained. The solid curve once more shows the mean communication range for the P-3 tracks of the NC-117 and the dashed curve, with close correspondence, shows the same information for the NC-117 tracks of the P-3. The dividing line for higher power output in the Avoid I equipment is 9600 feet. That is, at 9600 feet and above, the power increases by 2 to 4 db above the value at 9500 feet and below. With the reduced power, the curves accurately

COMMUNICATION RANGE AS A FUNCTION OF THE ANGLE BETWEEN RADIALS FLOWN. FLIGHT 7, 3 JULY 1974.

P-3 ABOVE NC-117, BOTH ABOVE 10K FEET

P-3 ALTITUDE 10.5K FEET CLIMBING TO 11.0K FEET

NC-117 ALTITUDE 10.0K FEET DIVING TO 9.6K FEET

FRUIT: 64K REPLIES/SEC  
1536 INTERROGATIONS/SEC  
IN BOTH AIRCRAFT.

EQUIVALENT RANGES ARE SHOWN WITH 6 db OF ATTENUATION IN RF LINK

SOLID LINE • P-3 TRACK OF NC-117

DASHED LINE X NC-117 TRACK OF P-3

RANGE WAS GENERALLY LIMITED BY GEOMETRIC PATTERN OF FLIGHT. ACTUAL COMMUNICATION RANGE WAS GENERALLY BUT NOT ALWAYS GREATER THAN THAT SHOWN. (SEE FLIGHTS 9, 11 WITH 9 db ATTENUATION.)

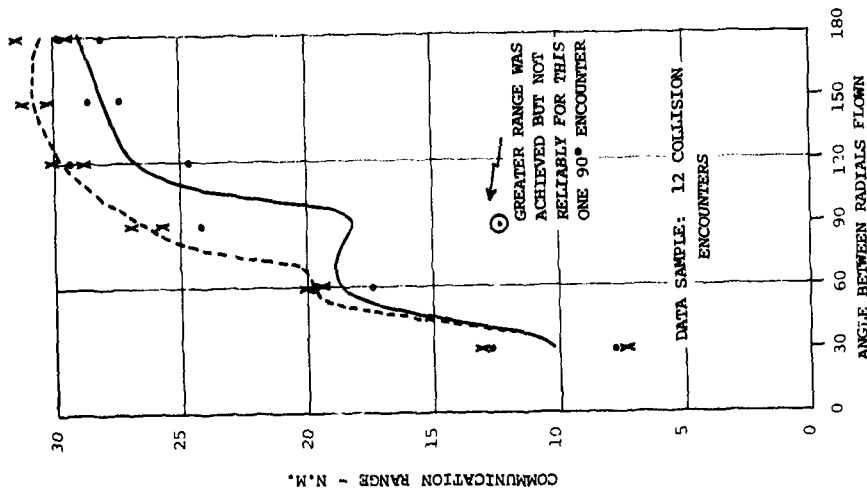

Figure VI-16. Communication Range, Flight 7, P-3A Above NC-117.

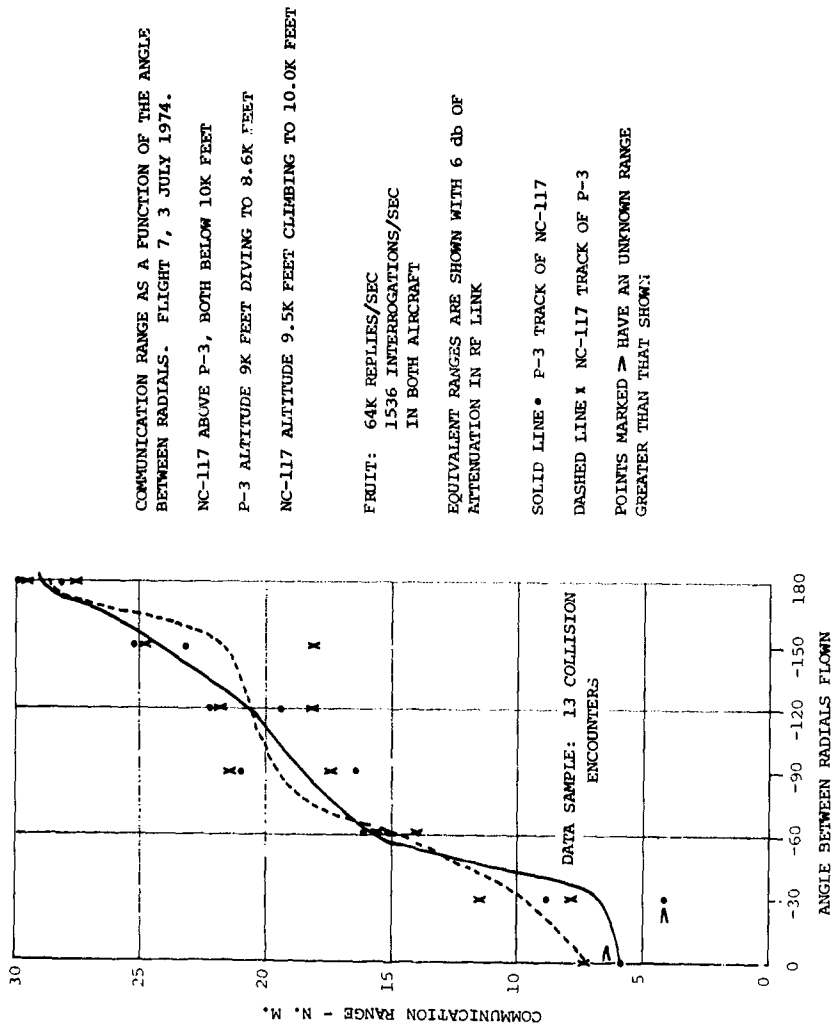
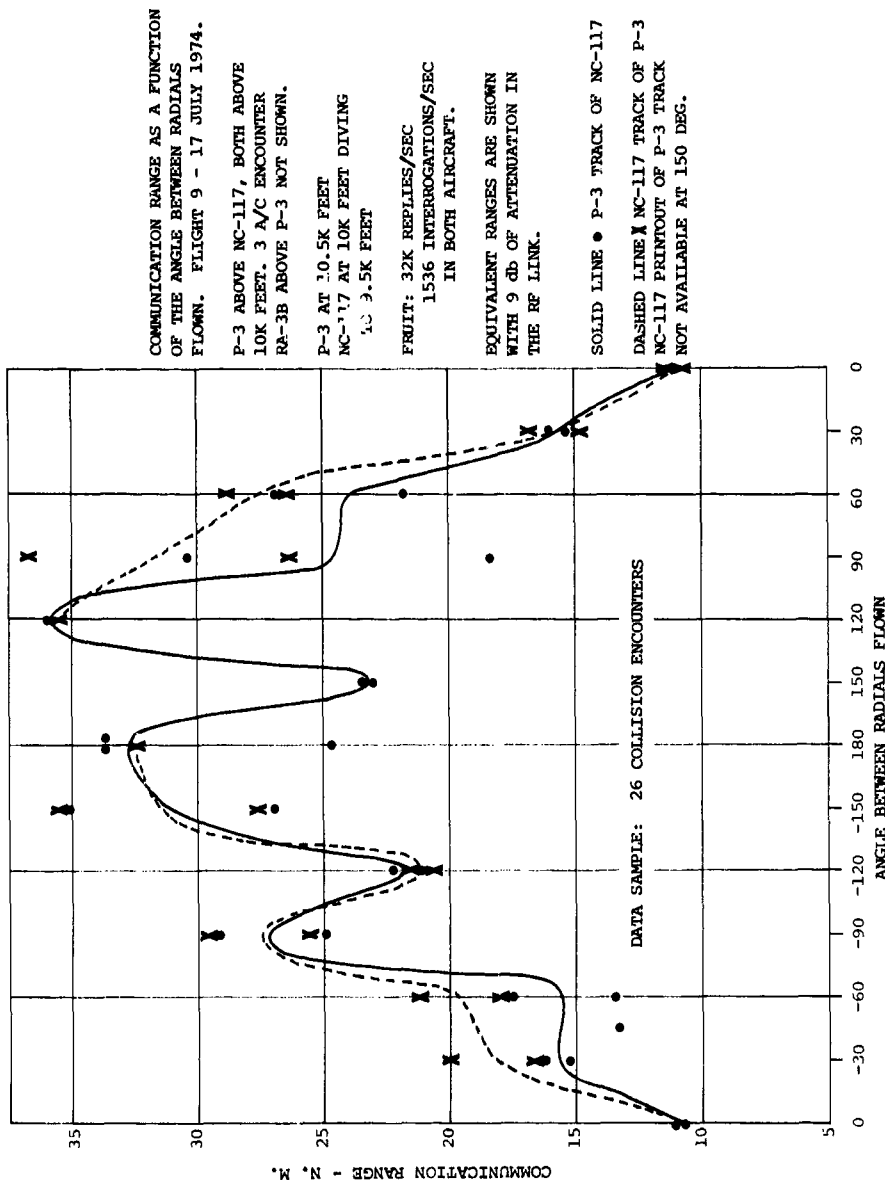

Figure VI-17. Communication Range, Flight 7. NC-117 Above P-3A.

reflect the communication range limits. Below 10,000 feet the maximum communication range requirement is for a head-on ( $180^\circ$ ) encounter at 550 knots. The TAU 2 threshold for this case is 7.9 miles. The recorded mean communication range of 29 miles at  $180^\circ$  thus represents a margin of 11.3 db. This large margin would tend to indicate that the Avoid I power below 10,000 feet can be reduced by more than 2 to 4 db. An accurate measurement of transmitter power was not made to verify the magnitude of the power reduction. It should be noted that a direct comparison between the second half of flight 7 (figure VI-17) below 10,000 feet and the first half of flight 7 (figure VI-16) above 10,000 feet cannot be made because of the change in antenna aspects from NC-117 above the P-3 to NC-117 below the P-3 plus the change from negative encounter angles to positive encounter angles. The second half of flight 7 was the only flight made with the NC-117 above the P-3.

Figure VI-18 (flight 9), 17 July 1974, is a complete 360-degree plot of communication range as a function of the angle between radials flown for the F-3 above the NC-117. This was a 3-aircraft encounter with the A-3 above the P-3 results shown elsewhere. The P-3 flew between the other two aircraft at 10,500 feet. The NC-117 commenced at 10,000 feet and followed dive commands which took it to 9,500 feet. The fruit in both aircraft was set at 32,000 replies per second and 1536 interrogations per second. With 9 db of external attenuation (3 db in the NC-117 and 6 db in the P-3), the limits of the communication range were determined and the mean values plotted. Again the solid curve represents the P-3 track of the NC-117 and the dashed curve represents the NC-117 track of the P-3. There was good communication range correspondence between the two tracks and both exceeded the extrapolated highest speed required amount by more than 6 db for all encounter angles. Due to instrumentation limitations, the NC-117 printout of its P-3 track was not available at 150 degrees; consequently, there is no NC-117 track recorded at this point.

Figure VI-19 for flight 11, 26 July 1974, shows results very similar to those of flight 9. Once more, this was a 3-aircraft encounter with the P-3 above the NC-117, and the A-3 above the P-3 not shown. The P-3 flew at 10,800 feet and the NC-117 commenced at 10,000 feet diving to 9,600 feet. The fruit rate in each aircraft was maintained at 32000/1536. Once more with 9 db of attenuation in the RF link, the solid curve represents the mean communication range of the P-3 tracking the NC-117, and the dashed curve represents the mean communication range of the NC-117 tracking the P-3. The apparent deviation in the correspondence of the two tracks at the  $-150$  and  $180$  encounter angles is due to the choice of starting points for equivalent continued round reliability. That is, the NC-117 had tracks at ranges corresponding to those of the P-3, but they were not as reliable and, therefore, a later (smaller) communication range was recorded as the starting point for comparable reliability. For the 11 collision encounters, there was an approximate 6 db margin or more for extrapolated highest speed cases over most of the encounter angles from  $-30^\circ$  to  $180^\circ$  in  $30^\circ$  steps. For the speeds flown, of course, the power margin was even greater.



COMMUNICATION RANGE AS A FUNCTION OF THE ANGLE BETWEEN RADIALS FLOWN. FLIGHT 9 - 17 JULY 1974.

P-3 ABOVE NC-117, BOTH ABOVE 10K FEET. 3 A/C ENCOUNTER. RA-3B ABOVE P-3 NOT SHOWN.

P-3 AT 10.5K FEET  
NC-117 AT 10K FEET DIVING  
10 9.5K FEET

FRUIT: 32K REPLIES/SEC  
1536 INTERROGATIONS/SEC  
IN BOTH AIRCRAFT.

EQUIVALENT RANGES ARE SHOWN WITH 9 db OF ATTENUATION IN THE RF LINK.

SOLID LINE ● P-3 TRACK OF NC-117

DASHED LINE X NC-117 TRACK OF P-3  
NC-117 PRINTOUT OF P-3 TRACK  
NOT AVAILABLE AT 150 DEG.

Figure VI-18. Communication Range, Flight 9, P-3A Above NC-117.

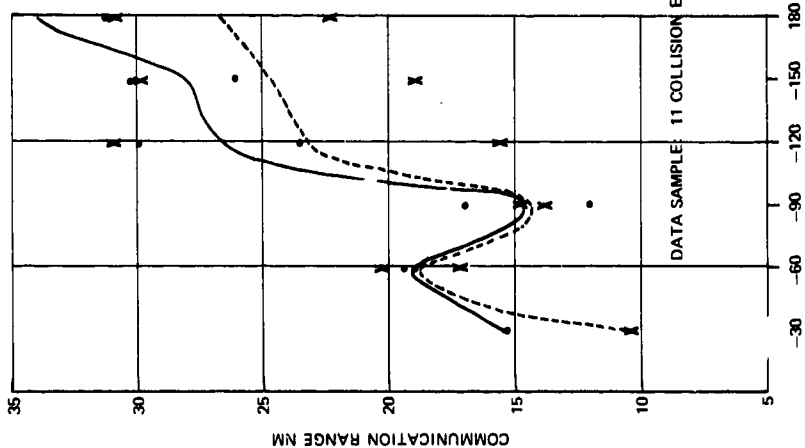

COMMUNICATION RANGE AS A FUNCTION  
OF THE ANGLE BETWEEN RADIALS FLOWN.  
FLIGHT 11 JULY 26, 1974.  
P3 ABOVE NC117, BOTH ABOVE 10K FEET.  
3-AIRCRAFT ENCOUNTER WITH THE RA3B  
ABOVE THE P3 NOT SHOWN.  
P3 AT 10.8K FEET  
NC117 AT 10.0K FEET DIVING TO 9.6K FEET.

FRUIT: 32K REPLIES/SEC  
1536 INT/SEC  
IN BOTH AIRCRAFT

EQUIVALENT RANGES ARE SHOWN WITH  
9 db ATTENUATION IN THE RF LINK.  
SOLID LINE • = P3 TRACK OF NC117  
DASHED LINE x = NC117 TRACK OF P3

Figure VI-19. Communication Range, Flight 11, P-3A Above NC-117.

The combined average P-3 and NC-117 communication range as a function of the angle between radials flown for flights 9 and 11 is shown in figure VI-20. Both flights involved the P-3 above the NC-117 and both flights had 9 db of attenuation in the RF link. It can be seen that there was more than enough coverage of the required 15.1 mile communication range at 180 degrees and corresponding coverage with adequate margin at all of the other encounter angles flown. For example, the extrapolated 1200-knot worst case margin at 180° was 31.5/15.1 or 6.4 db, while the extrapolated 450-knot worst case tail chase margin was 10.9/6.8 or 4.1 db. The largest margin for the extrapolated case of two 600-knot aircraft occurred at an encounter angle of plus 120° where the margin was 35.6/13.3 or 8.6 db.

#### COMMUNICATION RANGE - RA-3B VERSUS NC-117 FLIGHTS

This section discusses the results of the communication range flights involving the A-3 and the NC-117 aircraft. The only information available was that obtained from the repeated -90° encounters of flights 9 and 11 with the A-3 above the NC-117. As explained previously, the A-3 and the NC-117 flew figure eights displaced in space by 90° while the P-3 flew its daisy pattern.

Figure VI-21 is a scatter diagram for the communication range between the A-3 and NC-117 for flights 9 and 11. For flight 9 shown on the left, the A-3 flew at 11,000 feet climbing to 12,000 feet, while the NC-117 flew at 10,000 feet diving to 9,500 feet. Both aircraft had 32K fruit replies per second, with the interrogation quads being 1536 for the NC-117 and less than 1200 for the A-3. The mean communication range for the A-3 was 17.2 miles compared to a mean of 17.4 miles for the NC-117. The right-hand portion of the graph shows the results for flight 11 with the A-3 initially at 11,500 feet climbing to 11,800 feet, and the NC-117 initially at 10,000 feet diving to 9,600 feet. The A-3 had no fruit injected, while the NC-117 had 32,000 replies and 1536 interrogations per second. The mean communication range for the A-3 was 19.4 miles compared to a mean of 22.4 miles for the NC-117. The ranges plotted for both flights are equivalent ranges appropriate to the use of 3 db of external attenuation in the RF link.

The overall average communication range for all 32 collision encounters of both aircraft for both flights was 18.6 miles. Since a 90° encounter above 10,000 feet for two 600-knot aircraft would require a communication range of 11.2 miles, the mean value of 18.6 miles represents a 4.4 db margin. For a speed ratio of 13 to 7 roughly corresponding to the starting ranges of the A-3 and the NC-117 from the "collision" point over the TACAN station, the faster aircraft would be flying at 600 knots and the slower at 323 knots to preserve the same antenna look angle. The closing range rate would then be 681 knots, for which the required communication range would be 9.37 miles and the margin would be 6 db.

COMBINED AVERAGE P-3 AND NC-117  
 COMMUNICATION RANGE AS A FUNCTION  
 OF THE ANGLE BETWEEN RADIALS.  
 FLIGHTS 9 AND 11 - 17 & 26 JULY  
 1974.

P-3 ABOVE NC-117.  
 BOTH ABOVE 10,000 FEET.

EQUIVALENT RANGE WITH 9 db  
 OF ATTENUATION IN THE RF LINK.

THIRD AIRCRAFT (RA-3B) IN  
 3-AIRCRAFT ENCOUNTER NOT SHOWN.

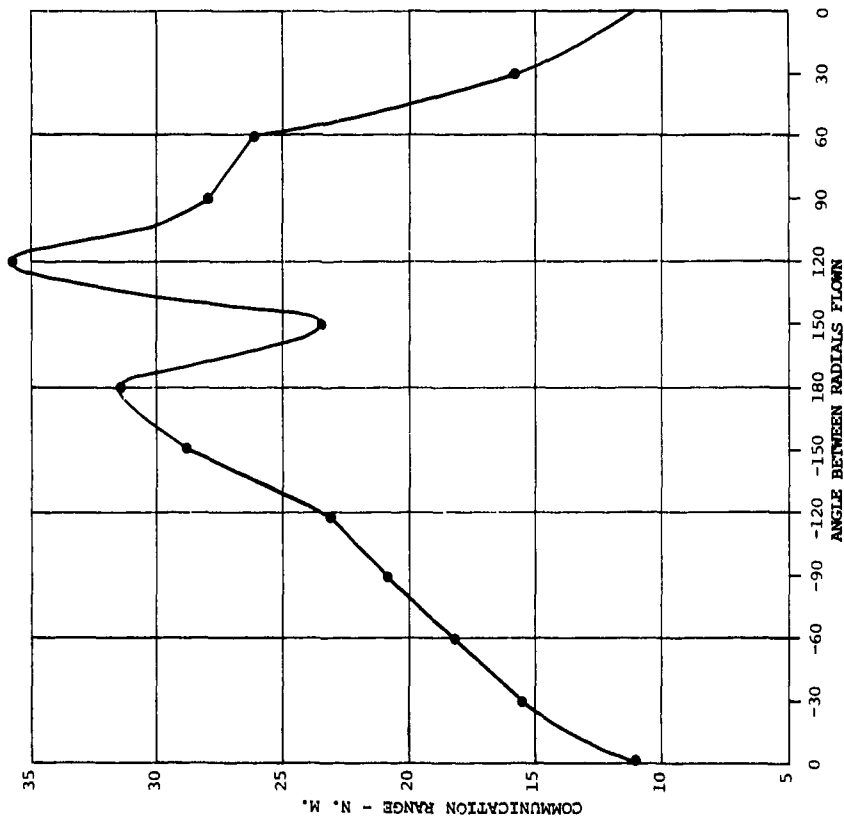

Figure VI-20. Communication Range, Flights 9 and 11, P-3A Above NC-117.

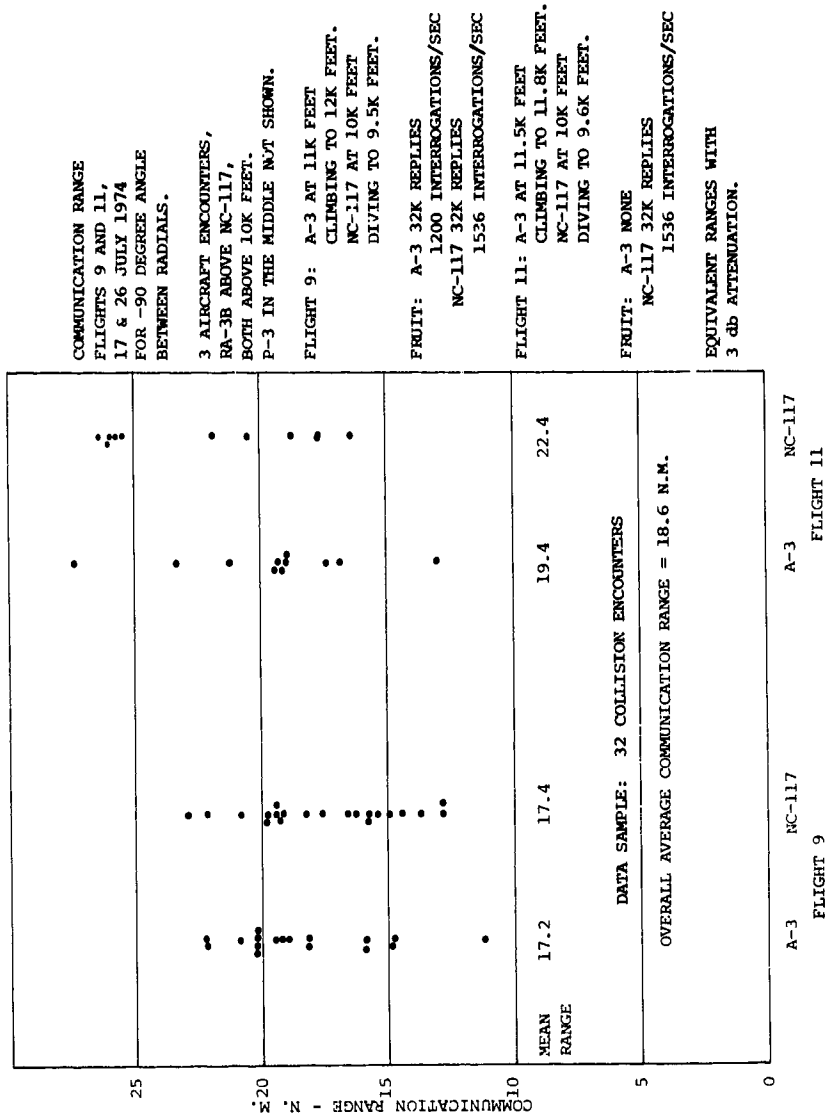

Figure VI-21. Communication Range, Flights 9 and 11, RA-3B Above NC-117.

## ROUND AND DISPLAY RELIABILITY

## INTRODUCTION

Having established an adequate communication range, it is necessary to evaluate the ability of the Avoid I to give correct information to the pilot for subsequent rounds up to the "collision point" when no evasive action is taken or up to the "clear" point when evasive maneuvers are employed. Of course, in these flights, a safe altitude separation was maintained up to the collision point. Since above 10,000 feet, two aircraft within 800 feet are considered co-altitude, it was possible to fly co-altitude encounters safely.

The Avoid I equipment requires two threats out of three rounds, for aircraft within  $\pm 1300$  feet of altitude, before displaying the threat to the pilot. The same criteria holds for retention of the display. Therefore, display reliability differed from round reliability and both were recorded and plotted in the graphs which follow. Aircraft threats within  $\pm 1300$  feet are displayed every 3 seconds either as Tau threats ( $\pm 800$  feet above 10,000 feet) or as P5 or M5 threats ( $\pm 900$  to  $\pm 1300$  feet). The P5 and M5 threats are advisories to limit rate of climb (P5) or descent (M5) to less than 500 feet per minute.

For threats beyond  $\pm 1300$  feet of altitude, the round time is 6 seconds, and the 2 out of 3 criteria is not used. However, a 3-second display memory is employed. That is, a threat is acquired for display purposes the first round in which it appears. The display is then retained for an additional 3 seconds. Thus, one such successful threat detection round resulted in 2 consecutive 3-second displays. Conversely, one such lost threat detection round was counted as 2 lost 3-second displays. The threats beyond  $\pm 1300$  feet were P10, P20, M10, M20 advisories, limiting aircraft climb and descent rates respectively to 1,000 feet and 2,000 feet per minute.

For purposes of round and display reliability, all threats were treated as either Tau 2 or Tau 1, depending on the range divided by range rate criteria. If the altitude separation was such that a climb/dive command was not given ( $>800$  feet), the rounds were called equivalent Tau 1 rounds when the Tau 1 threshold was crossed. However, if evasive actions were called for and taken, then the rounds after which the aircraft had separated to greater than 800 feet, were counted as Tau 2 rounds and Tau 2 displays, even though the range divided by range rate criteria would still place them in the Tau 1 zone. In effect, the distinction in this report was between displays requiring positive pilot action, and those which were in the nature of negative actions (like "do not turn") or advisories. The former were counted as Tau 1 and the latter as Tau 2. Predicted co-altitude threats requiring the pilot to level off were therefore classified as Tau 1 regardless of whether they occurred in a Tau 1 or Tau 2 zone. Since the overall reliability results were good, the above distinctions in classifying rounds

as Tau 2 or Tau 1 had no material effect except to simplify the classification process. Because of some of these distinctions, coupled with the 2 out of 3 display criteria for some threats and not for others, plus differences between "normal" mode of operation and "unrestricted interrogation" mode, as well as differences arising out of one aircraft being below the 9,600-foot boundary and one above ( $\pm 600$ -foot co-altitude versus  $\pm 800$ -foot co-altitude), there is not always a balance between the number of rounds and number of displays. Neither is there necessarily a balance between the number and type of rounds and displays for one aircraft versus the number and type of rounds and displays for the target aircraft in a given encounter or flight. The procedure followed was to divide the rounds of a given encounter into those which occurred before Tau 2, during Tau 2 and during Tau 1. Those which occurred before Tau 2 for a given encounter angle on a given flight were used to associate a round reliability with the communication range previously recorded and discussed for that encounter angle. Only lost rounds and displays were considered as part of the round and display reliability of this section, since the emphasis here was on the ability to maintain communication between two threatening aircraft. Problems of wrong altitude correlation and false alarm due to fruit looking like a target are dealt with elsewhere. Suffice it to say, there was a problem of distinguishing some of the altitude boundaries to better than  $\pm 100$  feet and occasionally to  $\pm 200$  feet, due primarily to the difficulty of holding a critical altitude gate to a tolerance of  $\pm 1$ ns per foot. This is being changed to 2ns per foot in future equipment. Most of the fruit targets appeared in the wide range bins designed for supersonic capability which was not a part of this evaluation. Even then, the two out of three criteria kept such displays to a minimum. Nevertheless, the false alarm problem, better studied as part of extensive bench tests, is considered serious enough to warrant special precautions and design changes in future versions of the Avoid equipment.

#### RELIABILITY - P-3 VERSUS RA-3B FLIGHTS

This section discusses the round and display reliability results for those flights involving the P-3 and RA-3B aircraft. After discussing similar results for flights involving the P-3 versus the NC-117 and the RA-3B versus the NC-117 in subsequent sections, a summary of all the reliability results is given indicating overall satisfactory performance.

Figure VI-22 gives the round reliability results for flight 4 on 24 April 1974, corresponding to the communication range results of Figure VI-6 with the P-3 1100 feet above the A-3. The reliability is plotted as a function of the angle between radials flown. The lower graph gives the round reliability as recorded in the P-3, while the upper graph gives the round reliability as recorded in the A-3. Because of the altitude separation, the Tau 1 and Tau 2 rounds are equivalent Tau rounds in place of the actual P5 and M5 rounds (limit rate of climb or descent to  $\pm 500$  feet per minute). There are four sets of numbers on each bar graph. These correspond to the rounds before

ROUND RELIABILITY  
FROM START OF USABLE  
COMMUNICATION TO END  
OF THREAT, AS A  
FUNCTION OF THE ANGLE  
BETWEEN RADIALS FLOWN.  
FLIGHT 4, APRIL 24, 1974  
P3 AT 11.0K FEET  
A3 AT 9.9K FEET  
FRUIT: P3 32K REPLIES/SEC  
1536 INT/SEC  
A3 64K REPLIES/SEC  
1536 INT/SEC

TAU 1'S ARE EQUIVALENT  
NOT ACTUAL

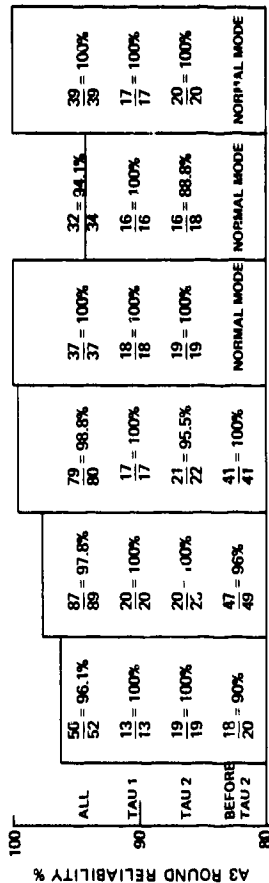

DATA SAMPLE: 11 COLLISION ENCOUNTERS

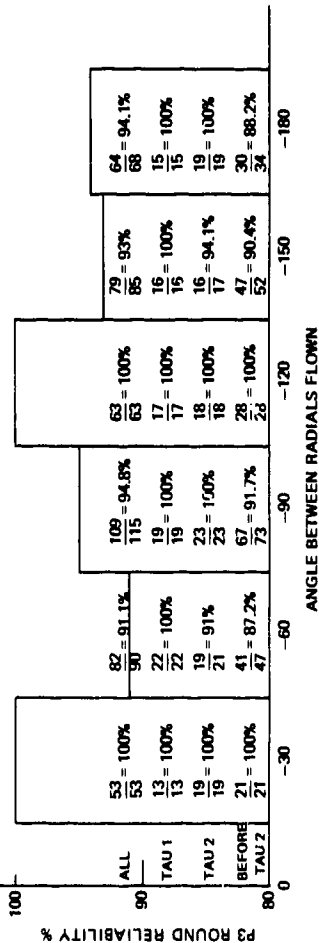

Figure VI-22. Round Reliability Versus Encounter Angle, Flight 4, P-3A Above RA-3B.

Tau 2, the Tau 2 rounds, the Tau 1 rounds, and all of the rounds. For example, at the  $-90^\circ$  encounter angle for the P-3, there were 67 successful communication rounds out of a possible recorded 73 before the Tau 2 threshold was reached giving a "before Tau 2" round reliability of 91.7 percent. It must be remembered that even though more than 73 round times may have elapsed from the start of communication to the crossing of the Tau 2 threshold for all of the  $-90^\circ$  encounters for this flight, it was necessary to switch to the "normal" operation sometime before reaching the Tau 2 threshold, thereby cutting off the recording of some of the additional possible "before Tau 2" rounds, since no threat yet existed. The exact time of switching from "unrestricted interrogation" to "normal" was a variable depending on project crew, aircraft, and flight pattern. Therefore, there was no correspondence between the "before Tau 2" rounds recorded in the A-3 and those recorded in the P-3. As an extreme case, there were no "before Tau 2" rounds recorded in the A-3 for the  $-120^\circ$ ,  $-150^\circ$ , and  $180^\circ$  encounters, because the A-3 was in the "normal" mode for those encounters. Referring back to the  $-90^\circ$  encounter for the P-3, the Tau 2 round reliability was 23 successes out of 23 opportunities or 100 percent. Similarly, the Tau 1 round reliability was 19 out of 19 or 100 percent. For all types of rounds, the success ratio was 109 out of 115 for a reliability of 94.8 percent. The overall round reliability, including all round types for each encounter angle, is the one represented by the height of each bar graph. Thus, it can be seen that the worst round reliability for all round types was 91.1 percent for the P-3 and 94.1 percent for the A-3, these reliabilities occurring at  $-60^\circ$  and  $-150^\circ$ , respectively. Significantly, the Tau 1 round reliability was 100 percent for all encounter angles.

A more generalized plot of round reliability for flight 4, without regard to the angle between radials flown, is shown in Figure VI-23 with the P-3 reliability again being shown on the bottom and the A-3 reliability on the top. As an example, the "before Tau 2" P-3 round reliability for all encounter angles was 234 successes out of 255 possible recorded attempts or 91.8 percent, compared to 106 out of 110 or 95.5 percent for the A-3. The "all rounds" reliability for the P-3 was 94.3 percent compared to 97.9 percent for the A-3. The lower right-hand section of the figure shows the combined P-3 and A-3 round reliabilities progressing from 93.2 percent before Tau 2, thru 97.4 percent for Tau 2 to 100 percent for Tau 1. The increased reliability would in general be expected at the closer ranges represented by Tau 1 rounds.

Corresponding to each graph of round reliability, there is a graph of pilot display reliability. This is, of course, the reliability which counts as far as the pilot is concerned. In general, but not always, the display reliability will be higher than the round reliability because of the use of the 2 out of 3 criteria previously mentioned. Figure VI-24 shows the display reliability as a function of the angle between radials flown for flight 4 in much the same manner as Figure VI-22 showed the corresponding round reliability, with the P-3 reliability on the bottom and the A-3 reliability on top. Here, three lines of information are shown for each bar graph, the Tau 2,

ROUND RELIABILITY BY  
ROUND TYPE WITHOUT  
REGARD TO ANGLE  
BETWEEN RADIALS FLOWN.  
FLIGHT 4, APRIL 24, 1974  
P3AT 11.0K FEET  
A3 AT 9.9K FEET

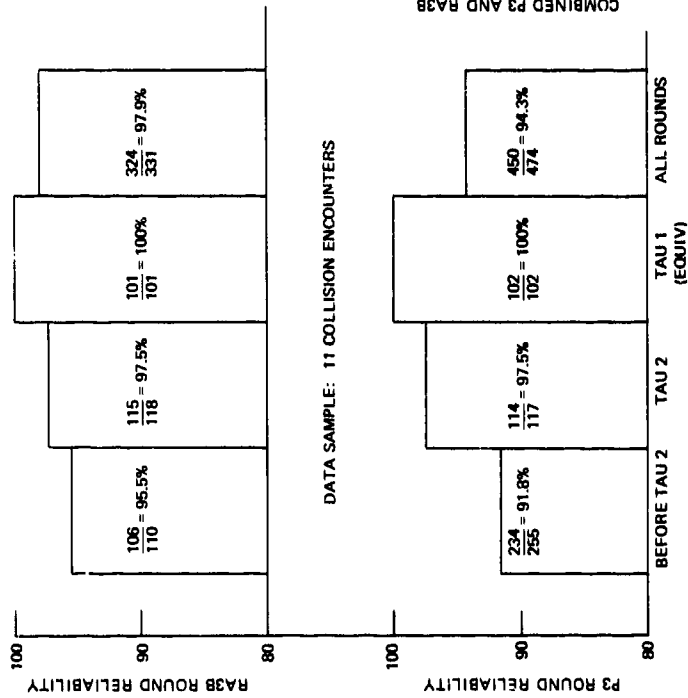

Figure VI-23. Round Reliability, Flight 4, P-3A Above RA-3B.

DISPLAY RELIABILITY  
AS A FUNCTION OF  
THE ANGLE BETWEEN  
RADIALS FLOWN  
FLIGHT 4 APRIL 24, 1974  
P3 AT 11.0K FEET  
A3 AT 9.9K FEET

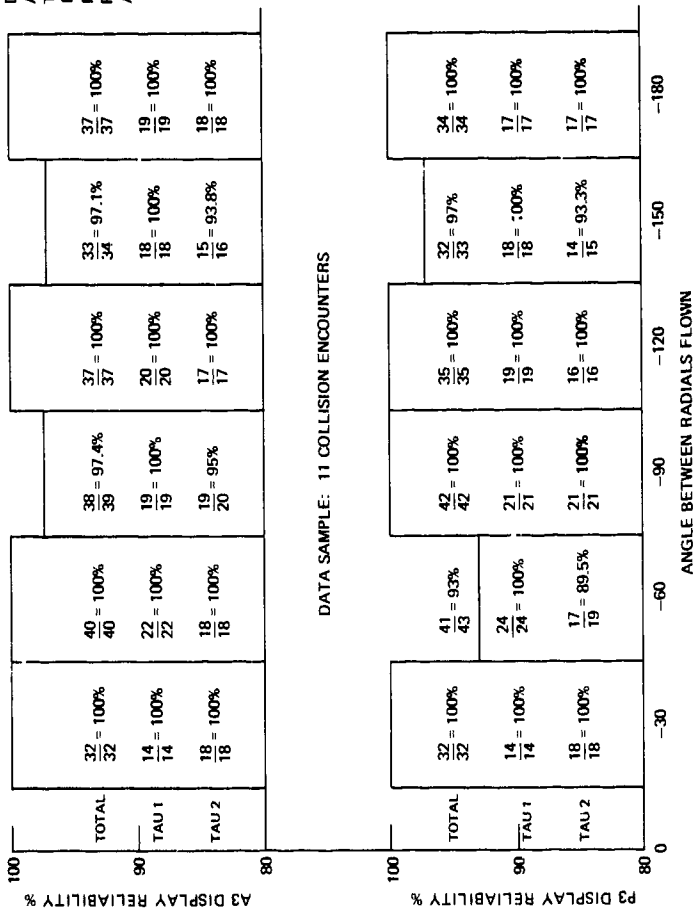

Figure VI-24. Display Reliability Versus Encounter Angle, Flight 4, P-3A Above RA-3B.

Tau 1, and total (Tau 1, Tau 2) display reliability. The height of each bar graph reflects the total combined Tau 1 and Tau 2 display reliability. The lowest display reliability was 93 percent at  $-60^\circ$  for the P-3, and 97.1 percent at  $-150^\circ$  for the A-3.

Corresponding to Figure VI-23 which shows round reliability without regard to the angle between radials flown, Figure VI-25 shows display reliability without regard to the angle between radials flown, with the P-3 reliability on the bottom and the A-3 reliability on the top. The combined P-3 and A-3 display reliability is shown in the bottom right-hand corner of the figure with a Tau 2 display reliability of 97.7 percent and a Tau 1 display reliability of 100 percent.

In a manner similar to the reliability graphs for flight 4, Figures VI-26, 27, and 28 present round and display reliability for the tailchase encounters of flight 12 on 29 July 1974. Figure VI-26 shows the round reliability for the A-3 tailchase of the P-3 from 700 feet below with 3 db attenuation in the RF link. The P-3 round reliability is shown on the bottom and the A-3 round reliability on the top. The combined P-3 and A-3 round reliability is shown on the bottom right with progressively increasing reliabilities from 91.9 percent before Tau 2 through 94.4 percent for Tau 2 to 97.4 percent for Tau 1.

The round reliability shown in Figure VI-27 is for an equivalent P-3 tailchase of the A-3 produced by the A-3 opening from the P-3. Since there is no actual threat in this case, the rounds could not be classified as Tau 1 or Tau 2. The combined P-3 and A-3 round reliability shown on the bottom right was 98.2 percent. This test, of course, had to be made in the unrestricted mode of operation. Again, there was 3 db of attenuation in the RF link. The display reliability corresponding to the tailchase round reliability of Figure VI-26 is Figure VI-28, which shows a Tau 1 and Tau 2 display reliability of 100 percent.

The foregoing round and display reliabilities involved the P-3 flying above the A-3. The remainder of this section involves the A-3 flying above the P-3. Figure VI-29 shows the round reliability for the A-3 above the P-3 in the 3-aircraft encounter of flight 9 on 17 July 1974, with initial altitude separation of 500 feet and the A-3 taking the required climb maneuver evasive action from 11,000 feet to 11,900 feet. The P-3 round reliability as before is shown on the bottom and the A-3 round reliability is shown on the top, both as a function of the angle between radials flown with 6 db of attenuation in the RF link. The results were satisfactory, except for the  $-120^\circ$  encounter angle for which the P-3 Tau 2 round reliability was only 72 percent and the A-3 was 73.7 percent. Nevertheless, the important Tau 1 round reliability even for this poor encounter angle was 93 percent for the P-3 and 93.8 percent for the A-3.

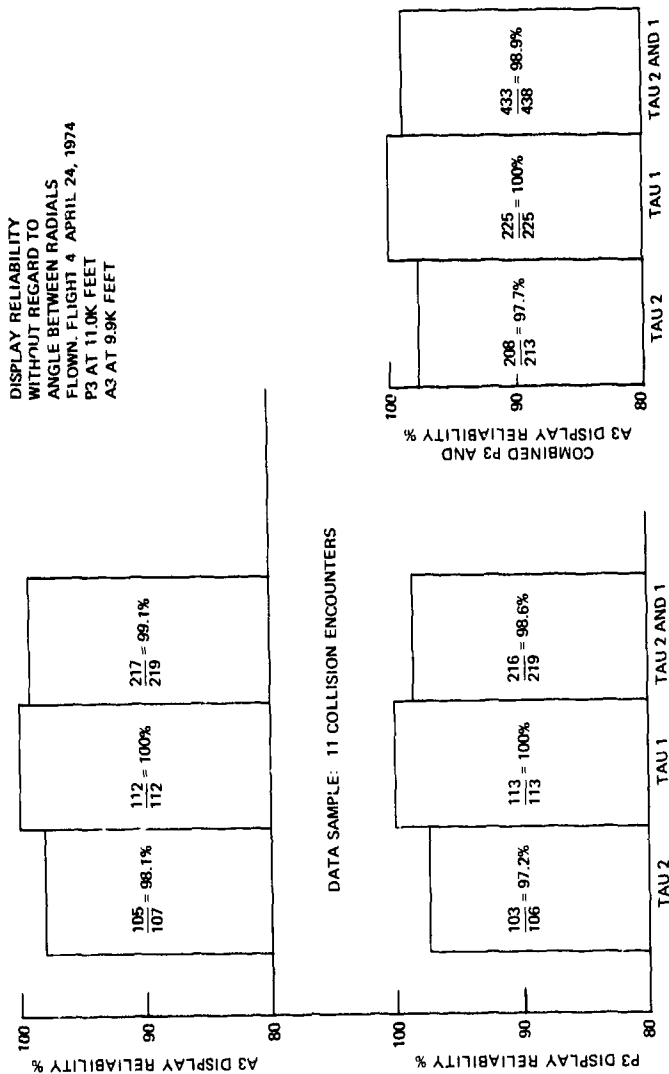
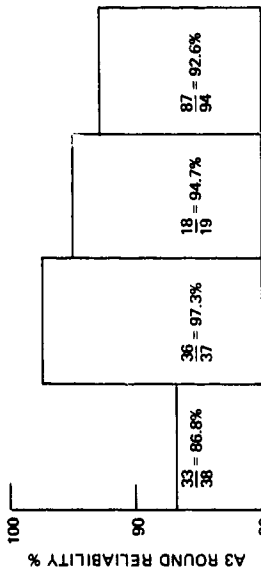

Figure VI-25. Display Reliability, Flight 4, P-3A Above RA-3B.

ROUND RELIABILITY FROM START OF  
 USABLE COMMUNICATION TO END OF  
 THREAT FOR A3 TAILCHASE OF P3.  
 FLIGHT 12 JULY 29, 1974  
 P3 AT 11.8K FEET CLIMBING TO 12K FEET  
 A3 AT 11.1K FEET DIVING TO 10.6K FEET  
 FRUIT: P3 32K REPLIES/SEC  
 1536 INT/SEC  
 A3 NONE  
 3db ATTENUATION IN RF LINK



DATA SAMPLE: 2 COLLISION  
 ENCOUNTERS

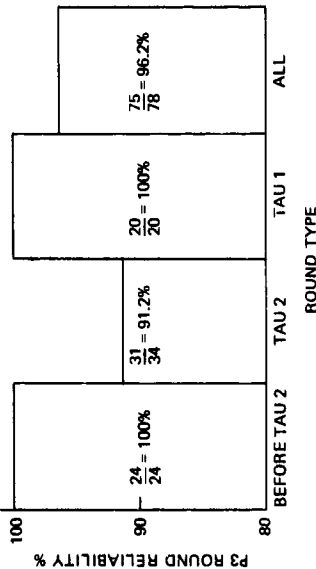
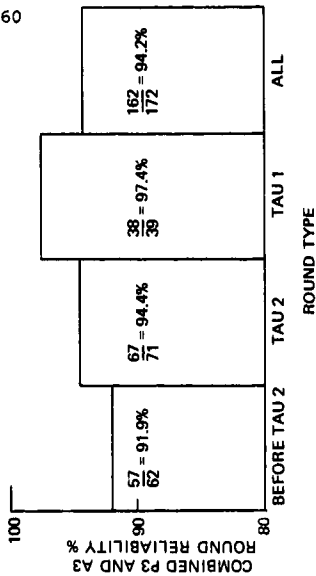

Figure VI-26. Round Reliability, Flight 12, RA-3B Tail Chase of P-3A From Below.

ROUND RELIABILITY FOR EQUIVALENT  
 P3 TAIL CHASE OF A3. FLIGHT 12 JULY 29, 1974  
 P3 AT 12K FEET  
 A3 AT 11.1K FEET  
 FRUIT: P3 32K REPLIES/SEC  
 1536 INT/SEC  
 A3 NONE  
 3 db ATTENUATION IN RF LINK  
 UNRESTRICTED MODE OF INTERROGATION

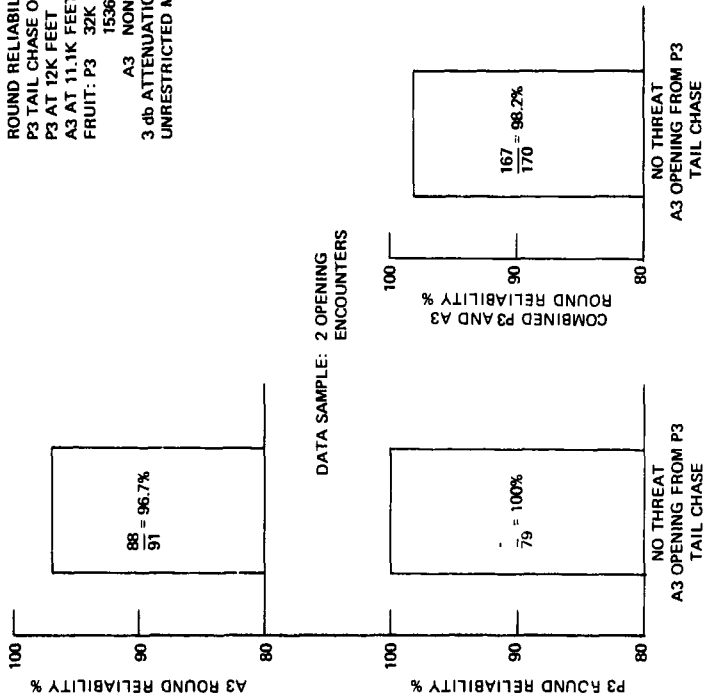

Figure VI-27. Round Reliability, Flight 12, Equivalent P-3A Tail Chase of RA-3B from Above

DISPLAY RELIABILITY FOR A3 TAIL CHASE  
 OF P3 FLIGHT 12 JULY 29, 1974  
 P3 AT 11.8K FEET CLIMBING TO 12K FEET  
 A3 AT 11.1K FEET DIVING TO 10.6K FEET  
 FRUIT: P3 32K REPLIES/SEC  
           1536 INT/SEC  
           A3 NONE  
 3 db ATTENUATION IN RF LINK

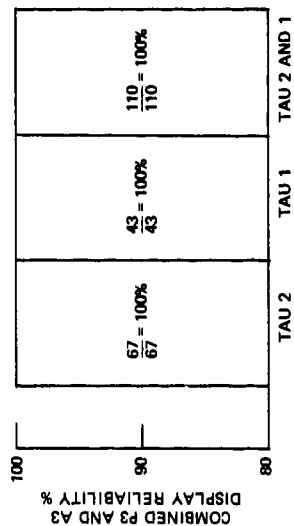
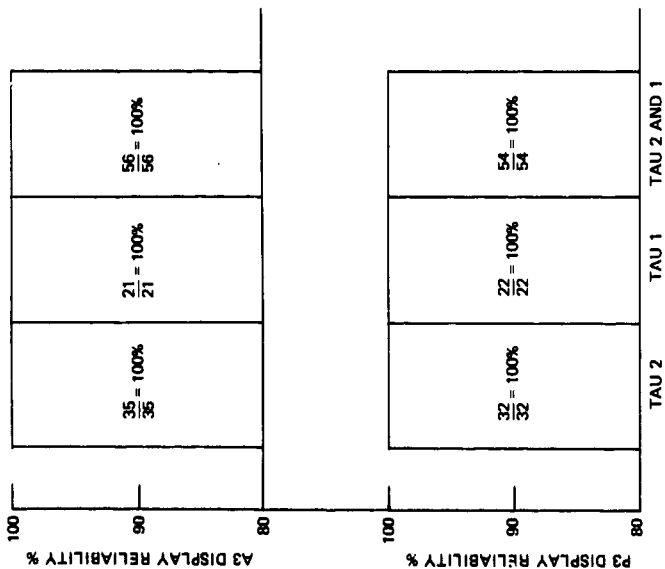

Figure VI-28. Display Reliability, Flight 12, RA-3B Tail Chase of P-3A from Below.

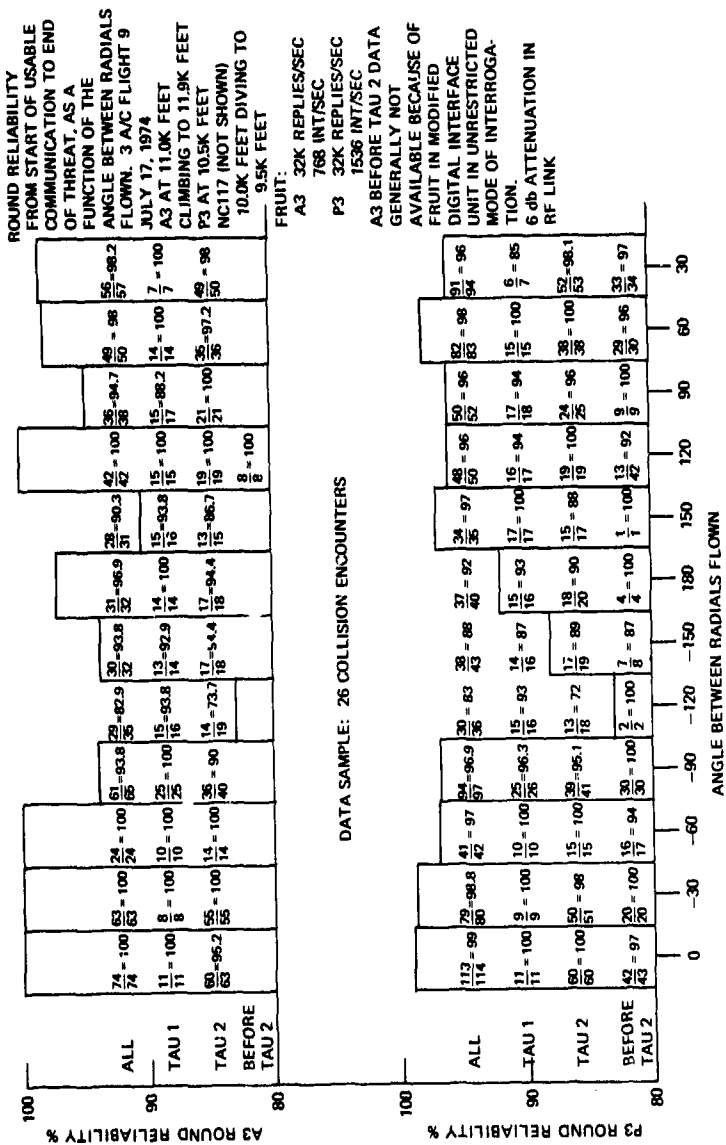

Figure VI-29. Round Reliability Versus Encounter Angle, Flight 9, RA-3B above P-3A

Figure VI-30 shows the more generalized results for the same flight 9 without regard to the angle between radials flown. The combined P-3 and A-3 round reliabilities are shown in the lower right-hand corner, with the overall round reliability being 96 percent.

The display reliability as a function of angle between radials flown for flight 9, Figure VI-31, shows some improvement over the P-3 Tau 2 round reliability at  $-120^\circ$  from 72 percent to 80 percent and a slight improvement over the A-3 round reliability from 73.7 percent to 76.5 percent, due to the use of the 2 out of 3 display acquisition and retention criteria. The important Tau 1 display reliability, however, is satisfactory at 94.1 percent for the P-3 and 100 percent for the A-3 at the  $-120^\circ$  encounter angle.

The display reliability for this flight without regard to the angle between radials flown is shown in Figure VI-32 with the P-3 display reliability on the bottom and the A-3 display reliability on top. The combined P-3 and A-3 display reliability results are shown in the lower right-hand section with excellent results; namely, 97.4 percent for Tau 2, 99.2 percent for Tau 1, and 98.1 percent for Tau 2 and Tau 1 combined. It must be remembered that these results were obtained with 6 db of external attenuation in the RF link.

Since flight 9 was a 3-aircraft flight, the P-3 in the middle had ample opportunity to react to simultaneous threats from above (A-3) and from below (NC-117). A typical simultaneous display from both threats would be "limit to 200 feet per minute above and below, no turn." This is equivalent to a Tau 2 warning above and a Tau 2 warning below. Another command might be "fly level" resulting from a Tau 1 above and Tau 1 below. Loss of the Tau 1 below would cause a change from "fly level" to "dive."

Figure VI-33 shows the simultaneous display reliability in the P-3 aircraft versus the angle between radials flown. Note that the angle between radials flown is different for the A-3/P-3 combination compared to the P-3/NC-117 combination. The worst case for the simultaneous display reliability was once more at the  $-120^\circ$  A-3/P-3 encounter angle, being 24 successes out of 28 opportunities or 85.7 percent. The simultaneous display reliability for all of the other encounter angles was greater than 93.5 percent with most being 100 percent. The top of Figure VI-33 shows a simultaneous display reliability of 97.7 percent for all angles combined. Lost displays were always either the P-3 loss of the A-3 or the P-3 loss of the NC-117, never loss of both at the same time. It must also be remembered that the A-3/P-3 link had 6 db external attenuation, while the P-3/NC-117 link had 9 db external attenuation. While these attenuations were good for the purpose of finding the maximum communication range, they placed an extra burden on the communication reliability requirements.

The round reliability versus angle between radials flown for the A-3 above the P-3 in the second 3-aircraft encounter, flight 11 on 26 July 1974, is shown in Figure VI-34, again with 6 db attenuation in the RF link. Here,

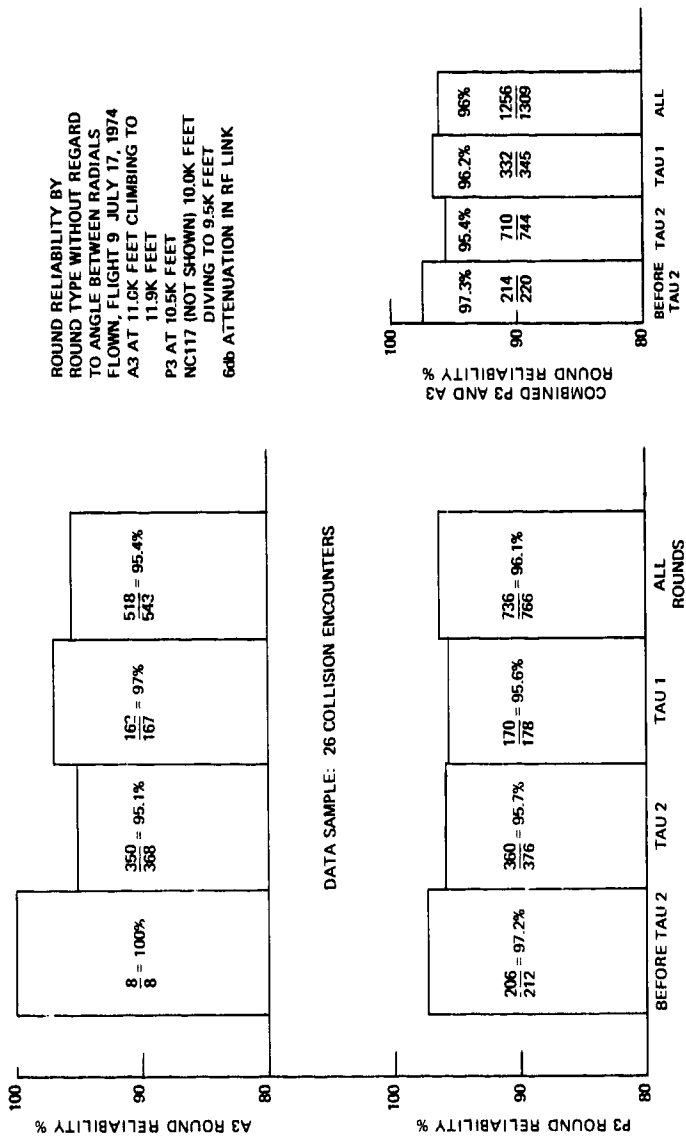
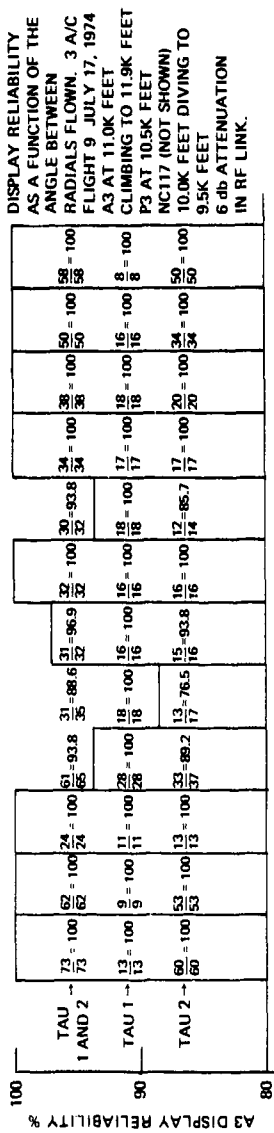

Figure VI-30. Round Reliability, Flight 9, RA-3B Above P-3A



DATA SAMPLE: 26 COLLISION ENCOUNTERS

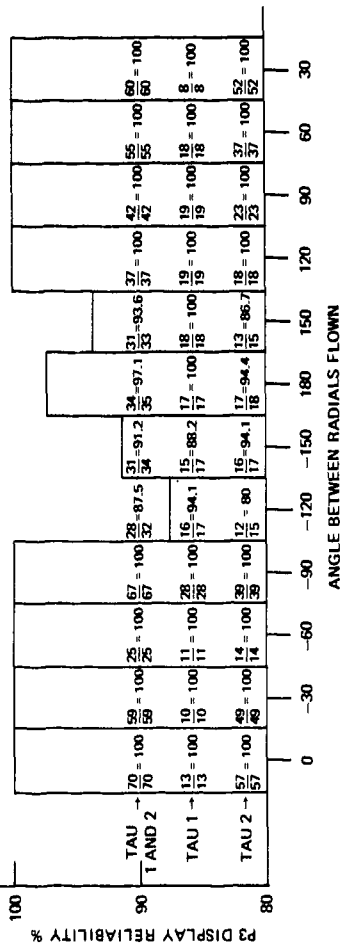

Figure VI-31. Display Reliability Versus Encounter Angle, Flight 9, RA-3B Above P-3A.

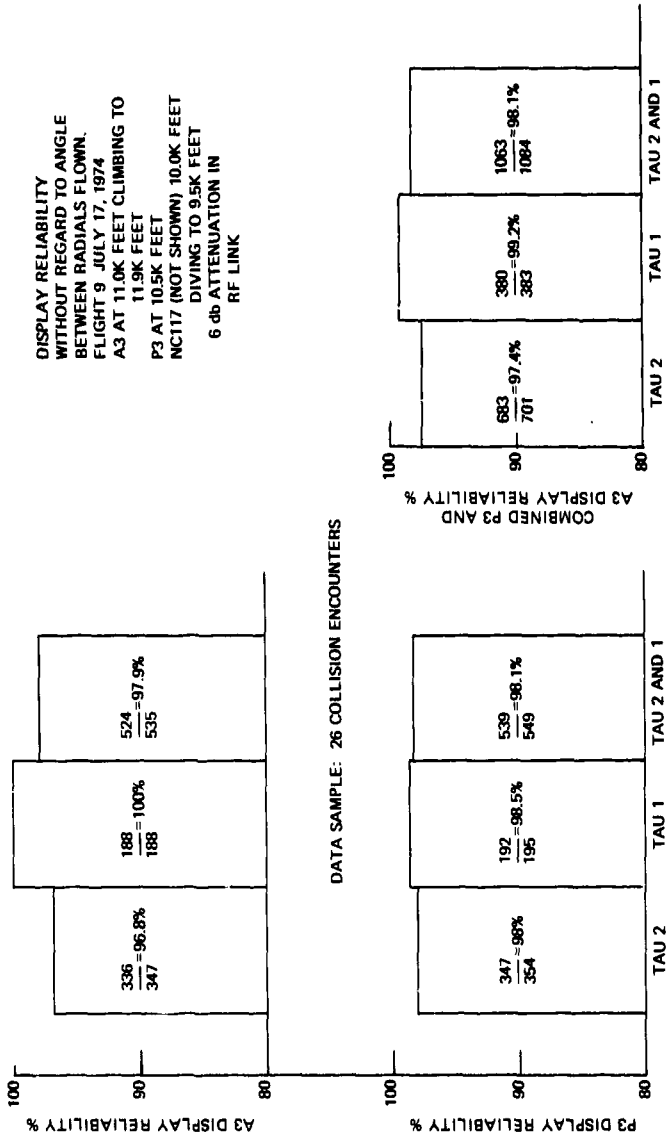
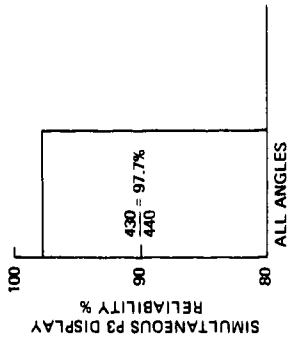

Figure VI-32. Display Reliability, Flight 9, RA-3B Above P-3A.

DATA SAMPLE: 26 3 AIRCRAFT COLLISION ENCOUNTERS



SIMULTANEOUS DISPLAY RELIABILITY IN P3 AIRCRAFT. FLIGHT 9 JULY 17, 1974

A3 AT 11.0K FEET CLIMBING TO 11.9K FEET  
 P3 IN THE MIDDLE AT 10.5K FEET  
 NC117 AT 10.0K FEET DIVING TO 9.5K FEET  
 6 db ATTENUATION IN A3/P3 LINK  
 9 db ATTENUATION IN P3/C117 LINK

TOP GRAPH: SIMULTANEOUS DISPLAY RELIABILITY FOR ALL ENCOUNTER ANGLES  
 BOTTOM GRAPH: SIMULTANEOUS DISPLAY RELIABILITY AS A FUNCTION OF THE ANGLE BETWEEN RADIALS FLOWN.

LOST DISPLAYS WERE ALWAYS EITHER P3 LOSS OF A3 OR P3 LOSS OF NC117, NOT LOSS OF BOTH.

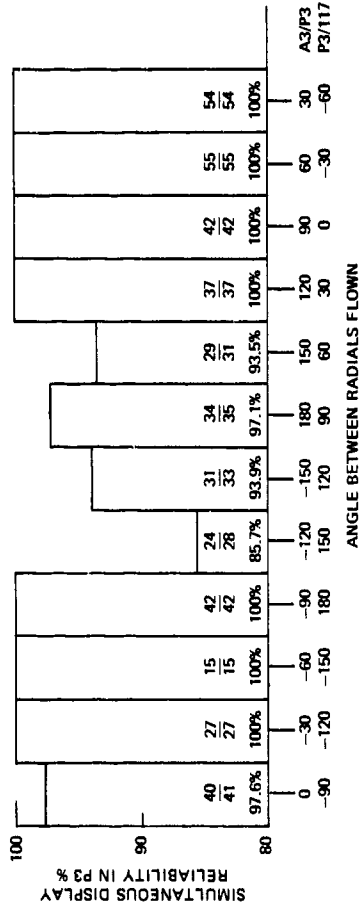
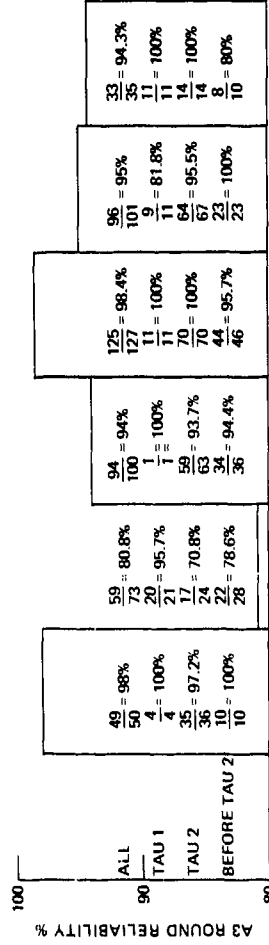

Figure VI-33. Simultaneous P-3A Display Reliability, Flight 9, Three Aircraft Encounters.

ROUND RELIABILITY FROM START OF USABLE COMMUNICATION TO END OF THREAT, AS A FUNCTION OF THE ANGLE BETWEEN RADIALS FLOWN, 3 A/C FLIGHT 11, JULY 26, 1974 A3 AT 11.5K FEET CLIMBING TO 11.7K FEET P3 AT 10.8K FEET NC17 (NOT SHOWN) AT 10K FEET DIVING TO 9.6K FEET



NADC-75056-60

FRUIT A3 NONE P3 32K REPLIES/SEC 1536 INT/SEC 6 db ATTENUATION IN RF LINK

DATA SAMPLE: 11 COLLISION ENCOUNTERS

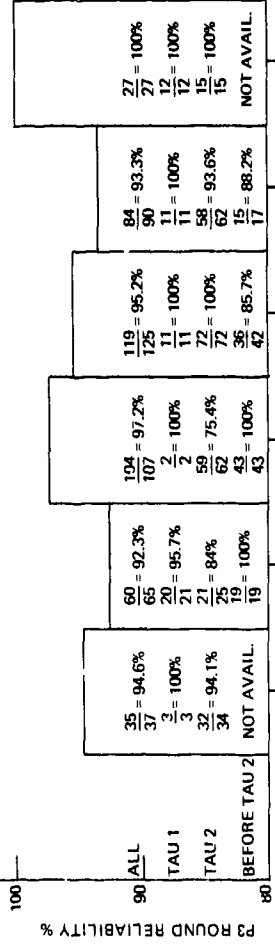

Figure VI-34. Round Reliability Versus Encounter Angle, Flight 11, RA-3B Above P-3A.

the only poor result was for the A-3 at  $-60^\circ$ . The Tau 2 round reliability was only 70.8 percent. Once more, however, the important Tau 1 round reliability was 95.7 percent. The more generalized flight 11 plot of round reliability without regard to angle between radials, Figure VI-35, shows the overall combined P-3 and A-3 round reliability as 94.5 percent. The individual P-3 and A-3 round reliabilities by round type are shown on the bottom and top bar graphs, respectively.

Figure VI-36 shows the display reliability as a function of the angle between radials flown for flight 11. There is some improvement at the  $-60^\circ$  encounter angle for the A-3 from a Tau 2 round reliability of 70.8 percent to a Tau 2 display reliability of 78.3 percent. The important Tau 1 reliability for this encounter angle improved from a round reliability of 95.7 percent to a display reliability of 100 percent.

The display reliability for this flight 11 without regard to the angle between radials flown is shown in Figure VI-37 with the combined P-3 and A-3 Tau 2 reliability being 97.2 percent and the combined Tau 1 reliability being 100 percent.

The special case for the 4 high-speed (850 knots) head-on encounters of flight 12, 29 July 1974, with the A-3 commencing from 700 feet above the P-3 is shown in Figure VI-38. The Tau 2 reliability is low both for the P-3 (86.1 percent) and the A-3 (76.2 percent), but the Tau 1 round reliability is still above 90 percent. Most of the lost rounds occurred near the Tau 2 threshold due to a malfunction in the P-3 Avoid equipment later found to be at least a 2 db loss of sensitivity with some unpredictable reliability results. The data was included here for completeness because there was no other high-speed communication reliability data available. Figure VI-39 which shows the display reliability for this flight indicates little change from the Tau 2 round reliability to the Tau 2 display reliability 82.5 percent versus 83 percent. This is because of the nature of the successive missed rounds near the Tau 2 threshold where the 2 out of 3 display criteria can offer no improvement over the round reliability; however, the Tau 1 reliability (combined P-3 and A-3) is improved from 90.9 percent to 100 percent because the 2 out of 3 criteria tolerates an occasional lost round without a corresponding lost display. It is clear, therefore, that once more the important Tau 1 display reliability was adequately preserved even in the face of the sensitivity malfunction.

If the display reliability results of all the flights involving the A-3 above the P-3 are combined and summarized, a clearer picture emerges on the overall performances of the Avoid I equipment in this flight configuration. Figure VI-40 shows the combined P-3 and A-3 display reliability as a function of the angle between radials flown for flights 9, 11, and 12 on July 17, 26, and 29, 1974. It must be remembered that there was 6 db of external RF attenuation for all encounters except the 4 high-speed head-on encounters of flight 12 for which there was a known malfunction of at least 2 db. In these flights, the

ROUND RELIABILITY BY  
 ROUND TYPE WITHOUT REGARD  
 TO ANGLE BETWEEN RADIALS  
 FLOWN. FLIGHT 11, 26 JULY 1974  
 A3 AT 11.5K FEET CLIMBING TO  
 11.7K FEET  
 P3 AT 10.8 K FEET  
 NC17 (NOT SHOWN) AT 10.0K FEET  
 DIVING TO 9.6K FEET  
 6 db ATTENUATION IN RF LINK.

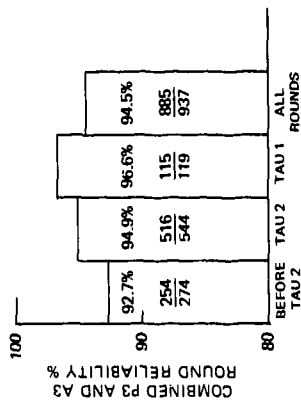
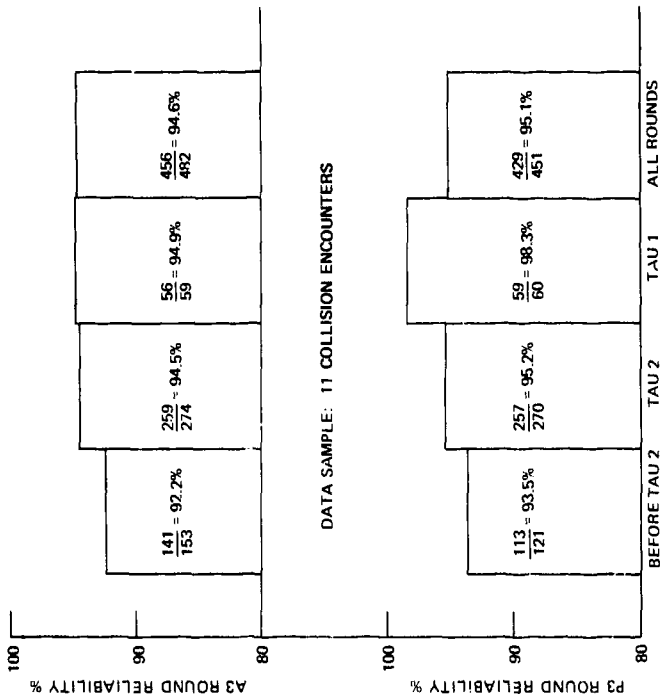

Figure VI-35. Round Reliability, Flight 11, RA-3B Above P-3A.

DISPLAY RELIABILITY AS A FUNCTION OF THE ANGLE BETWEEN RADIALS FLOWN. FLIGHT 11, 26 JULY 1974. A3 ALTITUDE 11.6K FEET P3 ALTITUDE 10.8K FEET 3 A/C ENCOUNTER NC117 (NOT SHOWN) ALTITUDE 10.0K FEET FRUIT ABOVE THRESHOLD RA3B NONE P3 32K REPLIES/SEC 1538 INT/SEC 6 db ATTENUATION IN RF LINK.

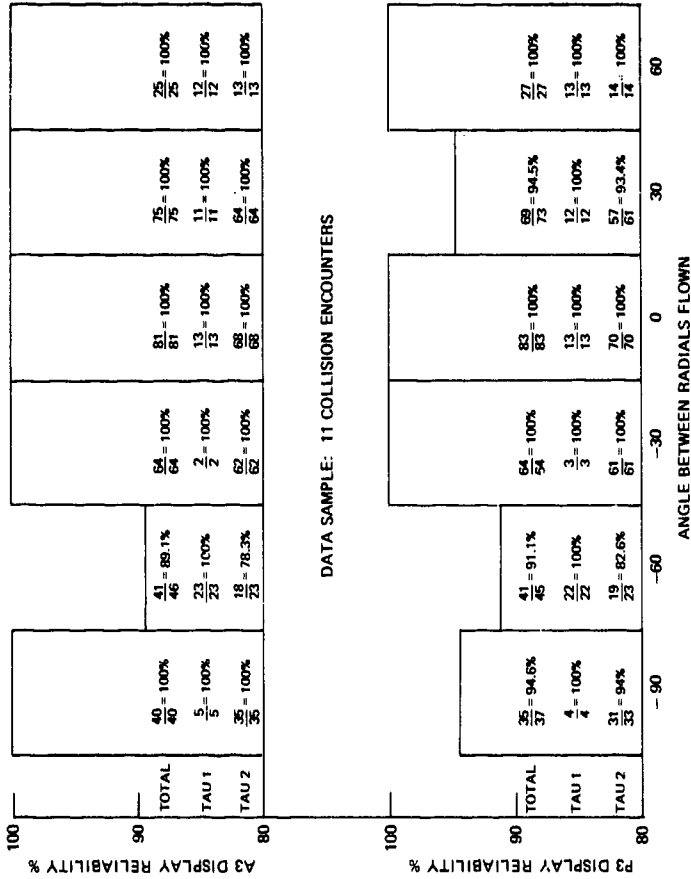

Figure VI-36. Display Reliability Versus Encounter Angle, Flight 11, RA-3B above P-3A.

DISPLAY RELIABILITY WITHOUT REGARD TO ANGLE BETWEEN RADIALS FLOWN. FLIGHT 11, 26 JULY 1974  
 A3 AT 11.6K FEET  
 P3 AT 10.8K FEET  
 3 A/C ENCOUNTER  
 NC117 (NOT SHOWN) AT 10.0K FEET  
 6 db ATTENUATION IN RF LINK.

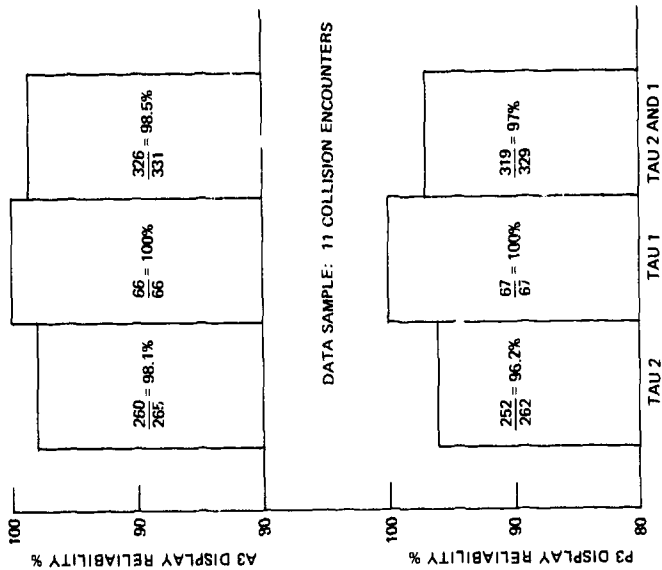

Figure VI-37. Display Reliability, Flight 11, RA-3B Above P-3A.

ROUND RELIABILITY FROM TAU 2  
THRESHOLD TO END OF THREAT FOR  
4 HIGH SPEED (860 KNOT) HEAD-ON  
ENCOUNTERS. FLIGHT 12, 29 JULY 1974  
A3 AT 11.8K FEET CLIMBING TO 12.4K FEET  
P3 AT 11.1K FEET

FRUIT: P3 32K REPLIES/SEC  
1536 INT/SEC  
A3 NONE

NOTE: MOST ROUNDS OCCUR AT TAU 2 THRESHOLD  
DUE TO MALFUNCTION IN P3 (LOW RECEIVER  
SENSITIVITY). RESULTS IN LATE BUT  
SUBSEQUENTLY RELIABLE WARNING.

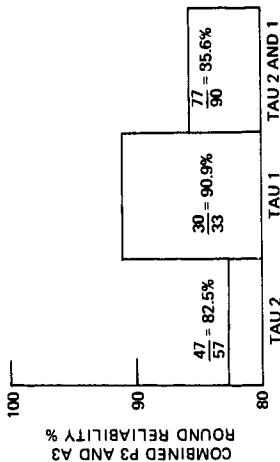
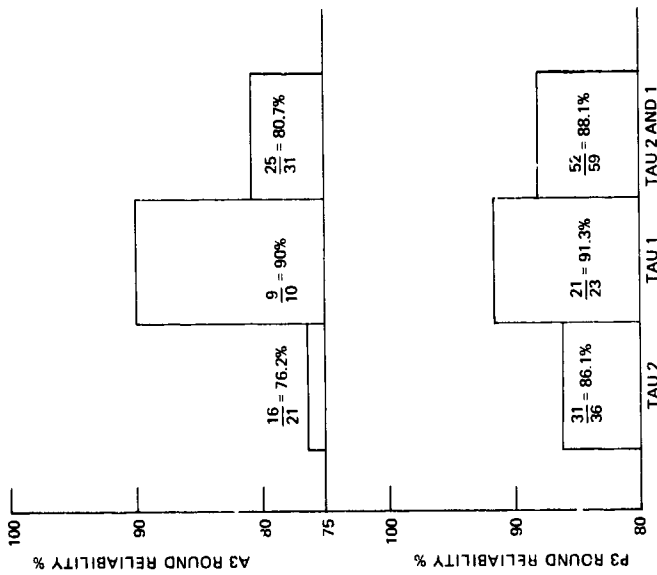

Figure VI-38. Round Reliability, Flight 12, RA-3B Above P-3A, Head-On Encounters.

DISPLAY RELIABILITY FOR 4 HIGH SPEED  
(850 KNOT) HEAD-ON ENCOUNTERS.  
FLIGHT 12, 29 JULY 1974.

A3 AT 11.8K FEET CLIMBING TO 12.4K FEET  
P3 AT 11.1K FEET

FRUIT: P3 32K REPLIES/SEC  
1536 INT/SEC  
A3 NONE

NOTE: POOR TAU 2 DISPLAY RELIABILITY OCCURS  
NEAR TAU 2 THRESHOLD DUE TO MALFUNCTION  
IN P3 (LOW RECEIVER SENSITIVITY). RESULTS  
IN LATE BUT SUBSEQUENTLY RELIABLE  
DISPLAY.

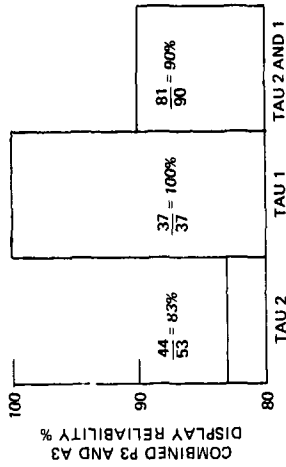
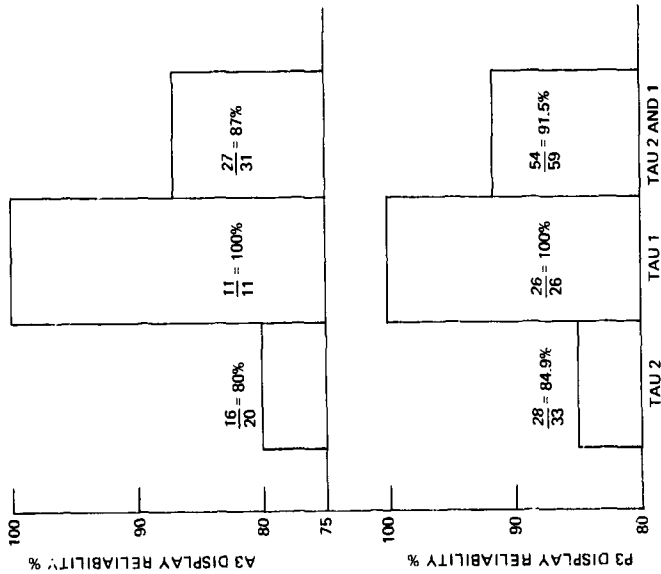

Figure VI-39. Display Reliability, Flight 12, RA-3B Above P-3A, Head-On Encounters.

DATA SAMPLE: 41 COLLISION ENCOUNTERS

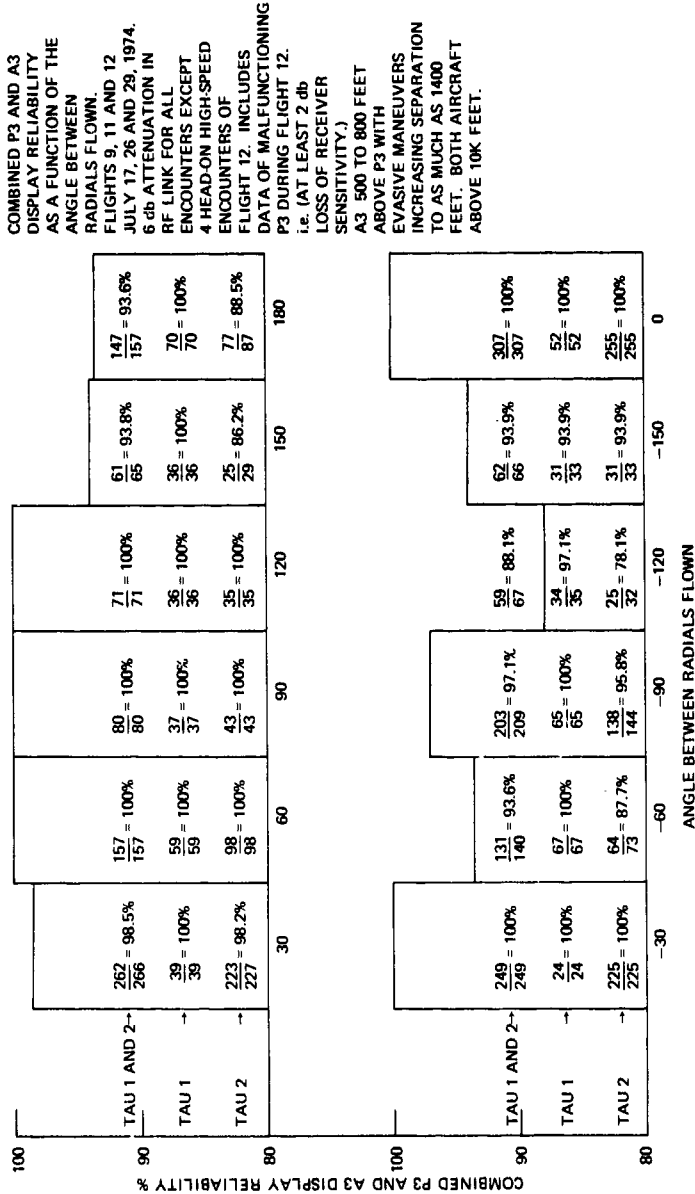

Figure VI-40. Display Reliability Versus Encounter Angle, Flights 9, 11, 12, RA-3B Above P-3A.

A-3 commenced from 500 to 800 feet above the P-3 with evasive maneuvers increasing the separation to as much as 1400 feet, with both aircraft above 10,000 feet.

The lower bar graphs cover the negative encounter angles while the top graphs cover the corresponding positive encounter angles for comparison purposes. The 0° tailchase encounter angle on the bottom is matched with the 180° head-on encounter angle on top. The height of each bar graph reflects the combined Tau 1 and Tau 2 display reliability for both aircraft at each encounter angle. The worst case, as expected from the previous individual flight results, was 88.1 percent for the -120° encounter compared to 100 percent for the positive 120° encounter angle. Significantly, however, the important Tau 1 display reliability for the negative encounter angle was 97.1 percent. The combined Tau 1 and Tau 2 display reliability was well above 90 percent for all other encounter angles with 5 of the 12 encounter angles having 100 percent Tau 1 and Tau 2 display reliability, and 10 of the 12 having 100 percent Tau 1 display reliability.

Figure VI-41 contains the same information as Figure VI-40 in a simpler, more generalized form without regard to encounter angle. It shows that the combined P-3 and A-3 overall display reliability for the case of the A-3 flying above the P-3 was 97.5 percent with the Tau 2 display reliability being 96.7 percent and the Tau 1 display reliability being 99.5 percent.

Figures VI-42 and 43 give a similar combined and summarized picture of the display reliability for flights 4 and 12, April 24 and July 29, 1974, involving the P-3 flying above the A-3. In this configuration, the P-3 flew from 700 to 1100 feet above the A-3 with both above 10,000 feet. No external attenuation was used except for 3 db on the two 0° encounters of flight 12. The effect of little or no external attenuation appears to be reflected in the good results obtained, with the lowest Tau 1 and Tau 2 display reliability being 96.1 percent for the 180° encounter angle of Figure VI-42. The more generalized results of Figure VI-43 for display reliability, without regard to encounter angle, show an overall Tau 2 and Tau 1 display reliability of 98.4 percent with the Tau 2 display reliability being 97 percent and the Tau 1 display reliability being 100 percent.

#### RELIABILITY - P-3 VERSUS NC-117 FLIGHTS

This section discusses the round and display reliability results for the flights involving the P-3 and NC-117 aircraft.

Figure VI-44 gives the round reliability results for flight 6 of July 1, 1974, corresponding to the communication range results of Figure VI-15, with the P-3 at 11,000 feet, 1000 feet above the NC-117 at 10,000 feet. The reliability is plotted as a function of the angle between radials flown, with the lower graph giving the round reliability as recorded in the P-3, while the

TOTAL COMBINED P3 AND A3 DISPLAY RELIABILITY WITHOUT REGARD TO ANGLE BETWEEN RADIALS FLOWN. FLIGHTS 9, 11 AND 12 - 17, 26 AND 29 JULY 1974. 6 db ATTENUATION IN RF LINK FOR ALL ENCOUNTERS EXCEPT 4 HEAD-ON HIGH-SPEED ENCOUNTERS OF FLIGHT 12. INCLUDES DATA OF MALFUNCTIONING P3 DURING FLIGHT 12. i.e. (AT LEAST 2 db LOSS OF RECEIVER SENSITIVITY). A3 500 TO 800 FEET ABOVE P3 WITH EVASIVE MANEUVERS INCREASING SEPARATION TO AS MUCH AS 1400 FEET. BOTH AIRCRAFT ABOVE 10K FEET.

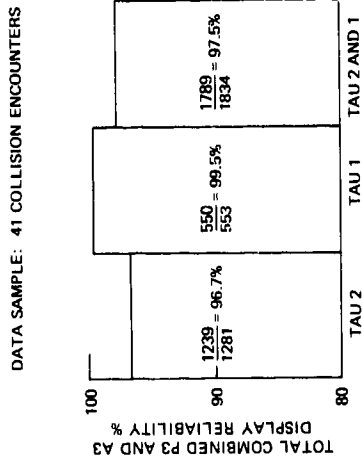

Figure VI-41. Display Reliability, Flights 9, 11, 12, RA-3B Above P-3A.

COMBINED P3 AND A3 DISPLAY  
 RELIABILITY AS A FUNCTION OF THE  
 ANGLE BETWEEN RADIALS FLOWN  
 FLIGHTS 4 AND 12 - 24 APRIL AND  
 29 JULY 1974. FLIGHT 12 INCLUDES  
 TWO 0° ENCOUNTERS WITH 3 db  
 ATTENUATION IN RF LINK AND  
 ONE 180° ENCOUNTER WITH 0 db.  
 P3 700 TO 1100 FEET ABOVE RA3B,  
 BOTH ABOVE 10K FEET.

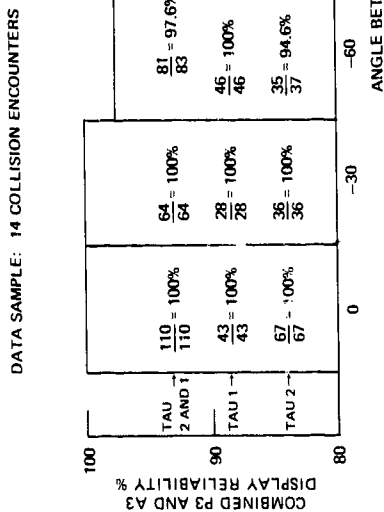

Figure VI-42. Display Reliability Versus Encounter Angle, Flights 4 and 12, P-3A Above RA-3B.

TOTAL COMBINED P3 AND A3 DISPLAY  
RELIABILITY WITHOUT REGARD TO  
ANGLE BETWEEN RADIALS FLOWN  
FLIGHTS 4 AND 12 - 24 APRIL AND  
29 JULY 1974. FLIGHT 12 TAIL CHASE  
0 ENCOUNTERS WITH 3 db  
ATTENUATION IN RF LINK.  
P3 700 TO 1100 FEET ABOVE RA3B  
BOTH ABOVE 10K FEET.

DATA SAMPLE: 14 COLLISION ENCOUNTERS

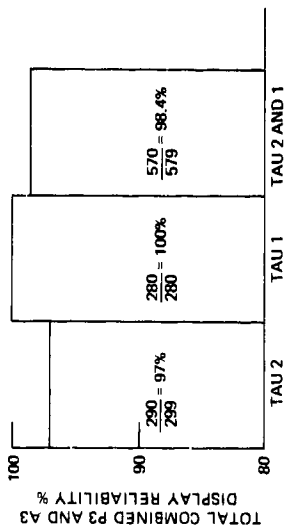
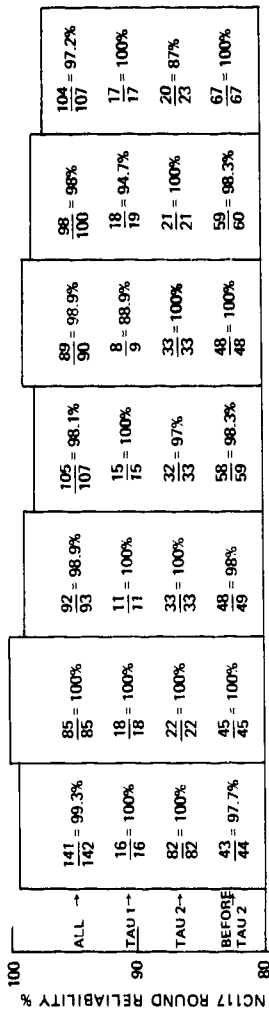

Figure VI-43. Display Reliability, Flights 4 and 12, P-3A Above RA-3B.

ROUND RELIABILITY  
FROM START OF  
USABLE COMMUNI-  
CATION TO END OF  
THREAT, AS A  
FUNCTION OF  
THE ANGLE  
BETWEEN RADIALS.  
FLIGHT 6, 1 JULY  
1974.

P3 AT 11.0K FEET.  
NC117 AT 10K FEET.  
FRUIT:  
P3 32K REPLIES/SEC  
1536 INT/SEC  
NC117  
64K REPLIES/SEC  
1536 INT/SEC  
TAU 1'S ARE  
EQUIVALENT  
NOT ACTUAL.

ZADC-75056-60



DATA SAMPLE: 14 COLLISION ENCOUNTERS  
(28 SETS OF DATA)

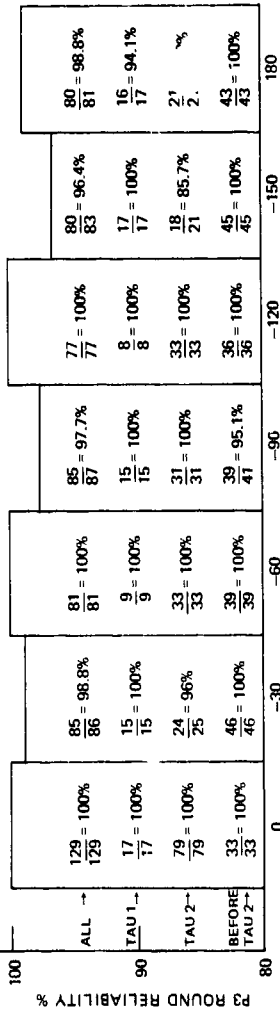

Figure VI-44. Round Reliability Versus Encounter Angle,  
Flight 6, P-3A Above NC-117.

upper graph gives the round reliability as recorded in the NC-117. Because of the altitude separation, the Tau 1 and Tau 2 rounds are equivalent Tau rounds in place of the actual P5 and M5 rounds (limit rate of climb or descent to  $\pm 500$  feet per minute). As usual, there are four sets of numbers on each bar graph. These correspond to the rounds before Tau 2, the Tau 2 rounds, the Tau 1 rounds, and all of the rounds, the height of the bar graphs representing the reliability of all of the rounds. The worst "all round" reliability was 96.4 percent at the  $-150^\circ$  encounter angle, which also had the worst Tau 2 round reliability of 85.7 percent for the P-3. The P-3 Tau 1 reliability for this encounter angle, however, was 100 percent.

Figure VI-45 gives the round reliability for flight 6 without regard to the angle between radials flown with the P-3 reliability on the bottom, the NC-117 reliability on top, and the combined P-3 and NC-117 reliability at the lower right. The latter shows a combined P-3 and NC-117 "all rounds" reliability of 98.7 percent.

The total Tau 1 and Tau 2 display reliability as a function of the angle between radials for flight 6, given by Figure VI-46, is nearly 100 percent perfect, except for the P-3 at the  $-150^\circ$  encounter angle (92 percent) and the NC-117 at  $180^\circ$  (95 percent). These excellent results, without external attenuation, were marred only by a Tau 2 display reliability of 84.2 percent in the P-3 at the  $-150^\circ$  encounter angle due to several lost rounds in a row, for which the two out of three display logic was no help.

The overall good display reliability, without regard to angle between radials flown, for this flight 6 is shown by Figure VI-47, with a combined P-3, NC-117 Tau 1 and Tau 2 display reliability of 99.3 percent.

Equally good round and display reliability results for the P-3 above the NC-117 were obtained for the first half daisy of flight 7 of 3 July 1974, with the addition of 6 db attenuation in the RF link. For this portion of flight 7, positive encounter angles were flown with the P-3 initially at 10,500 feet climbing to 11,000 feet and the NC-117 initially at 10,000 feet diving to 9,600 feet in response to the Tau 1 commands. Figure VI-48 depicts the round reliability as a function of the angle between radials flown with the lowest "all rounds" reliability being 90.4 percent for the P-3 at the positive  $150^\circ$  encounter angle. The round reliability without regard to the angle between radials flown is shown in Figure VI-49, with a combined P-3, NC-117 "all rounds" reliability of 96.6 percent. The display reliability as a function of the angle between radials for this portion of flight 7 is shown in Figure VI-50, where the lowest total Tau 1 and Tau 2 display reliability was 97.2 percent for the P-3 at the  $150^\circ$  and  $180^\circ$  encounter angles.

The overall good display reliability, without regard to the angle between radials flown for this first portion of flight 7 is shown in Figure VI-51, with a combined P-3, NC-117 Tau 1 and Tau 2 display reliability of 99.4 percent. With 6 db of attenuation, this is almost identical to the previous flight 6 results without attenuation.

ROUND RELIABILITY BY ROUND TYPE  
WITHOUT REGARD TO ANGLE BETWEEN  
RADIALS FLOWN.  
FLIGHT 6 - 1 JULY 1974  
P3AT 11K FEET  
NC117 AT 10K FEET

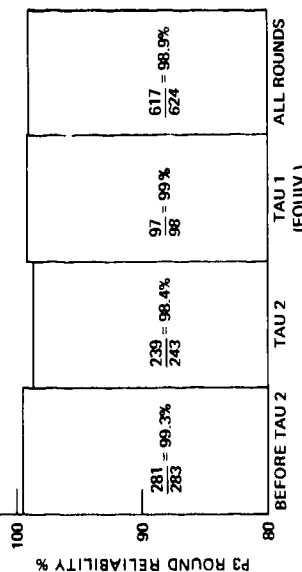
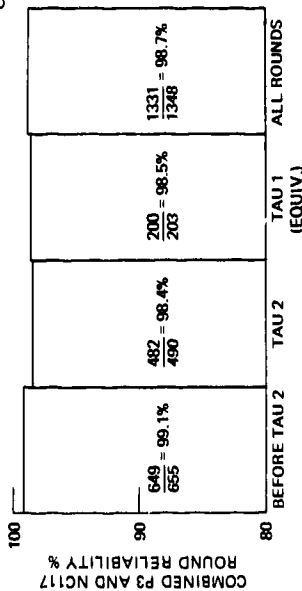
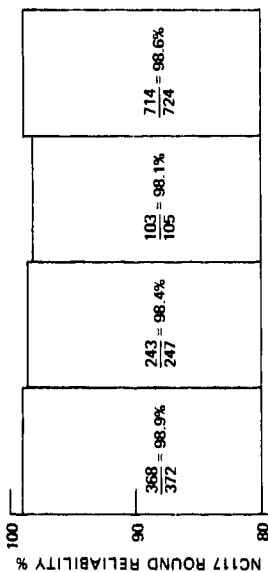

Figure VI-45. Round Reliability, Flight 6, P-3A Above NC-117.

DISPLAY RELIABILITY  
AS A FUNCTION OF  
THE ANGLE BETWEEN  
RADIALS.  
FLIGHT 6 - 1 JULY 1974.  
P3 AT 11K FEET  
NC117 AT 10K FEET

FRUIT:  
P3 32K REPLIES/SEC  
1536 INT/SEC  
NC117 64K REPLIES/SEC  
1536 INT/SEC

NO ATTENUATION  
IN RF LINK.

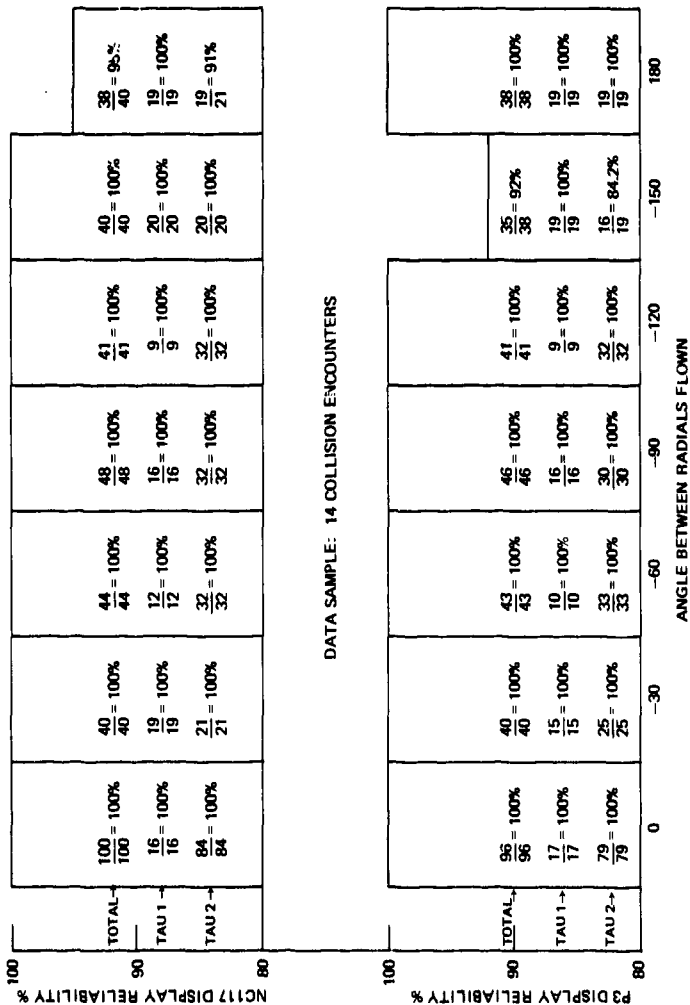

Figure VI-46. Display Reliability Versus Encounter Angle, Flight 6, P-3A Above NC-117.

DISPLAY RELIABILITY WITHOUT REGARD TO  
ANGLE BETWEEN RADIALS FLOWN.  
FLIGHT 6 - 1 JULY 1974.  
P3 AT 11K FEET. NC117 AT 10K FEET.

FRUIT: P3 32K REPLIES/SEC  
1536 INT/SEC

NC117

64K REPLIES/SEC  
1536 INT/SEC

NO ATTENUATION IN RF LINK.

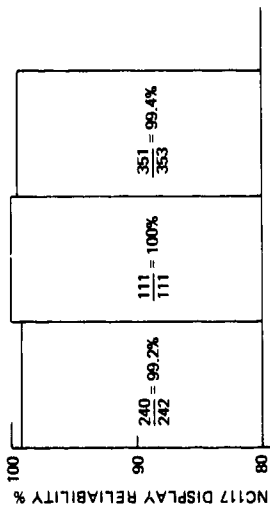

DATA SAMPLE: 14 COLLISION ENCOUNTERS

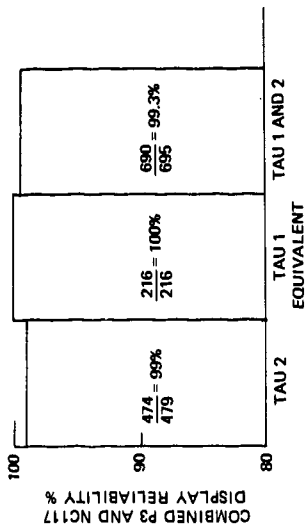
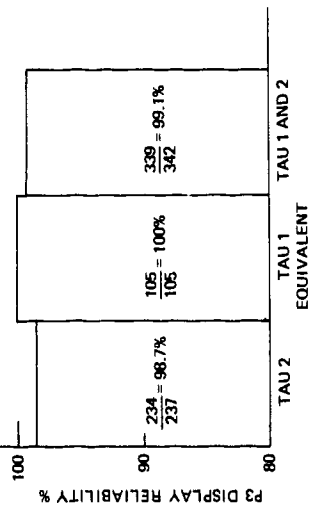

Figure VI-47. Display Reliability, Flight 6, P-3A Above NC-117.

ROUND RELIABILITY  
FROM START OF USABLE  
COMMUNICATION TO END  
OF THREAT, AS A  
FUNCTION OF THE ANGLE  
BETWEEN RADIALS  
FLOWN.

FLIGHT 7 - 3 JULY 1974.  
1ST HALF DAISY.  
P3 AT 10.5K FEET  
CLIMBING TO 11K FEET.  
NC117 AT 10.0K FEET  
DIVING TO 9.6K FEET.

FRUIT: 64K REPLIES/SEC  
1536 INT/SEC  
IN BOTH AIRCRAFT  
6 db ATTENUATION IN  
THE RF LINK.

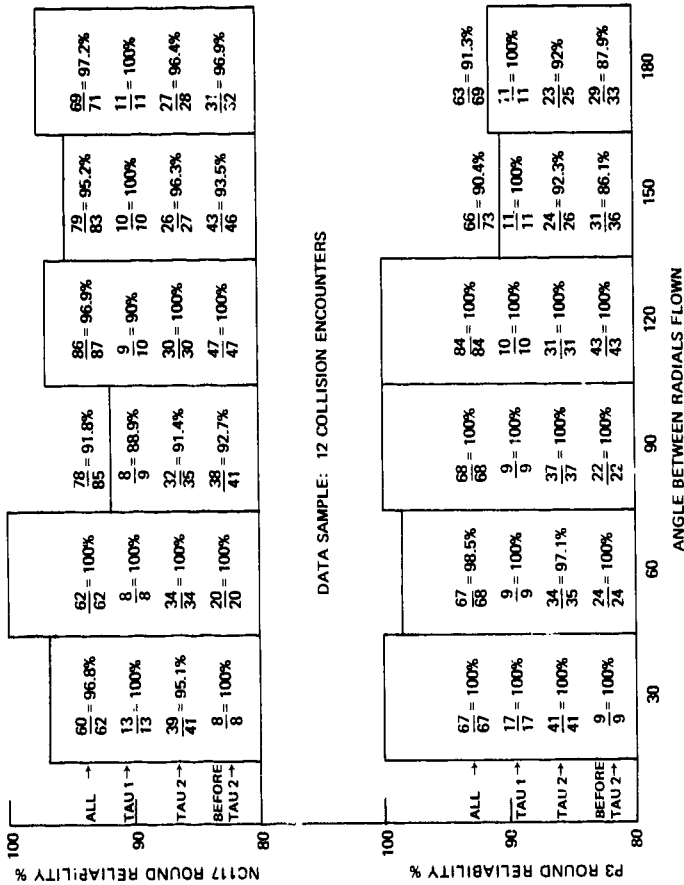

Figure VI-48. Round Reliability Versus Encounter Angle, Flight 7, P-3A Above NC-117.

ROUND RELIABILITY BY ROUND TYPE  
 WITHOUT REGARD TO ANGLE BETWEEN  
 RADIALS FLOWN.  
 FLIGHT 7 - 3 JULY 1974. 1ST HALF DAISY.  
 P3 AT 10.5K FEET CLIMBING TO 11K FEET  
 NC117 AT 10.0K FEET DIVING TO 9.6K FEET.  
 FRUIT: 64K REPLIES/SEC  
 1536 INT./SEC  
 IN BOTH AIRCRAFT  
 6 db ATTENUATION IN THE RF LINK.

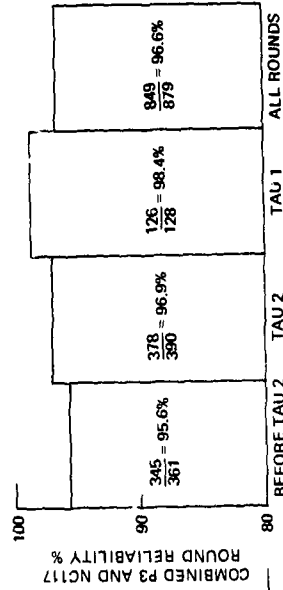
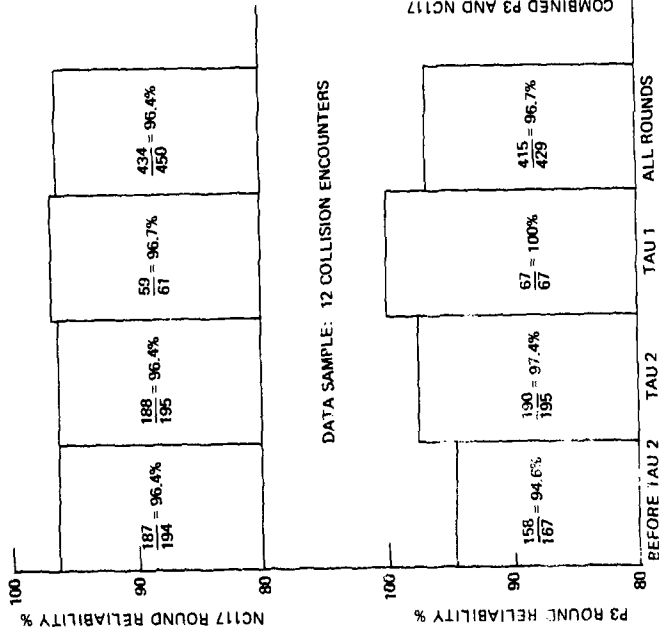

Figure VI-49. Round Reliability, Flight 7, P-3A Above NC-117.

DISPLAY RELIABILITY  
AS A FUNCTION OF THE  
ANGLE BETWEEN  
RADIALS. FLIGHT 7 -  
3 JULY 1974. 1ST HALF  
DAISY.  
P3 AT 10.5K FEET  
CLIMBING TO 11K FEET.  
NC117 AT 10.0K FEET  
DIVING TO 9.6K FEET.  
FRUIT: 64K REPLIES/SEC  
1536 INT/SEC  
IN BOTH AIRCRAFT  
6 db ATTENUATION IN  
THE F-F LINK.

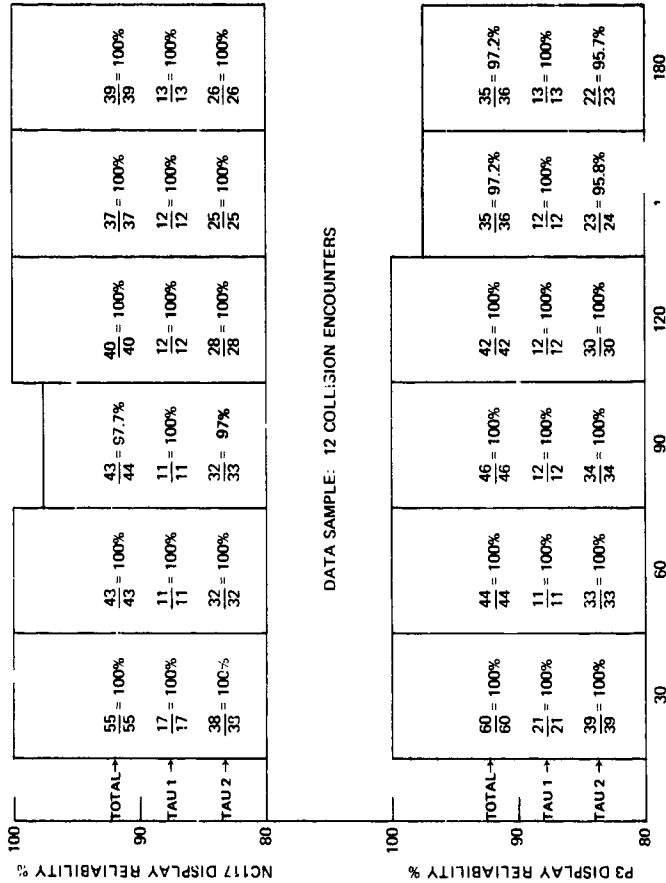
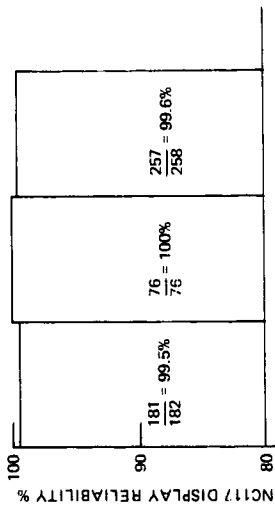

Figure VI-50. Display Reliability Versus Encounter Angle, Flight 7, P-3A Above NC-117.

DISPLAY RELIABILITY WITHOUT REGARD TO ANGLE BETWEEN RADIALS FLOWN.  
 FLIGHT 7 - 3 JULY 1974. 1ST HALF DAISY.  
 P3 AT 10.5K FEET CLIMBING TO 11K FEET.  
 NC117 AT 10.0K FEET DIVING TO 9.6K FEET.  
 FRUIT: 64K REPLIES/SEC  
 1536 INT/SEC  
 IN BOTH AIRCRAFT.  
 6 db ATTENUATION IN THE RF LINK.



DATA SAMPLE: 12 COLLISION ENCOUNTERS

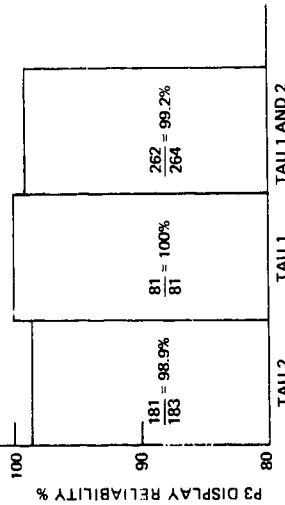
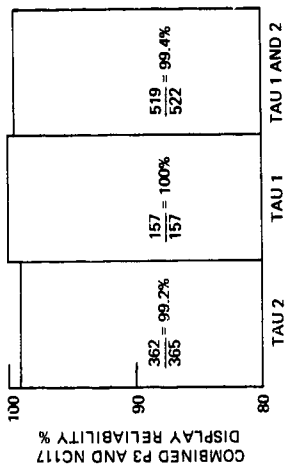

Figure VI-51. Display Reliability, Flight 7, P-3A Above NC-117.

For the second half of flight 7, the P-3 was flown at 9000 feet diving to 8600 feet, while the NC-117 was flown at 9500 feet climbing to 10,000 feet. This was the only flight configuration with the NC-117 above the P-3. The round reliability as a function of the angle between radials flown is shown in figure VI-52, corresponding to the communication range data of Figure VI-17. The worst "all rounds" reliability data was 88.1 percent for the P-3 at the  $-150^\circ$  encounter angle, with a Tau 2 reliability of 84.4 percent. Once more, however, the important corresponding Tau 1 round reliability was 100 percent. The more generalized results of round reliability without regard to the angle between radials flown for the second half of flight 7 are shown in Figure VI-53. The combined P-3 and NC-117 "all rounds" reliability is shown there as 95.6 percent. The display reliability as a function of the angle between radials is shown in Figure VI-54, where the worst total Tau 1 and Tau 2 display reliability is 87.2 percent at the  $-150^\circ$  encounter angle for the P-3. The corresponding display reliability in the target NC-117 aircraft was 100 percent, and the important Tau 1 display reliability in the P-3 aircraft was 100 percent.

The overall good display reliability, without regard to the angle between radials flown for this second portion of flight 7 is shown by Figure VI-55. With 6 db of external attenuation in the link, and with both aircraft below 9600 feet (i.e., lower power configuration), the combined P-3, NC-117 Tau 1 and Tau 2 reliability was 97.1 percent.

Flight 2, July 17, 1974, was the first of two 3-aircraft encounters. Round and display reliability results were available in both the P-3 and the NC-117 with the P-3 in the middle above the NC-117 and below the A-3. With 6 db attenuation in the P-3 and 3 db attenuation in the NC-117, there was a total of 9 db attenuation in the RF link. Figure VI-56 shows the round reliability as a function of the angle between radials for flight 9, with the P-3 at 10,500 feet and the NC-117 initially at 10,000 feet, diving to 9500 feet in response to its Tau 1 dive commands. There were occasions where the NC-117 properly cleared the Tau 1 threat earlier than the P-3, since at 9500 feet the NC-117 co-altitude limits were only  $\pm 600$  feet compared to the P-3 limits of  $\pm 800$  feet. There were other occasions, principally at the  $-30^\circ$  encounter angle, where the NC-117 started to climb after clearing the Tau 1 threat, and properly obtained the predicted co-altitude level off command. It should be recalled that these were classified as Tau 1 rounds in this report, giving use to a greater number of Tau 1 rounds in the NC-117 than in the P-3 at the  $-30^\circ$  encounter angle. The lowest "all rounds" round reliability (89.6 percent) occurred in the NC-117 at the  $-90^\circ$  encounter angle due to a Tau 2 round reliability of 83.9 percent. As usual, the Tau 1 round reliability was 100 percent at this encounter angle. The round reliability for this flight without regard to the angle between radials flown is shown in Figure VI-57, with the P-3 reliability on the bottom and the NC-117 reliability at the top. The combined P-3 and NC-117 round reliability shown at the bottom right for all of the rounds was 96.9 percent.

ROUND RELIABILITY FROM START OF USABLE COMMUNICATION TO END OF THREAT, AS A FUNCTION OF THE ANGLE BETWEEN RADIALS FLOWN, FLIGHT 7 - 3 JULY 1974. SECOND HALF DAISY. P3 AT 9K DIVING TO 8.6K FEET. NC117 AT 9.5K FEET CLIMBING TO 10K FEET.

DATA SAMPLE: 13 COLLISION ENCOUNTERS

FRUIT:

64K REPLIES/SEC  
1536 INT/SEC  
IN BOTH AIRCRAFT.  
6 db ATTENUATION  
IN THE RF LINK.

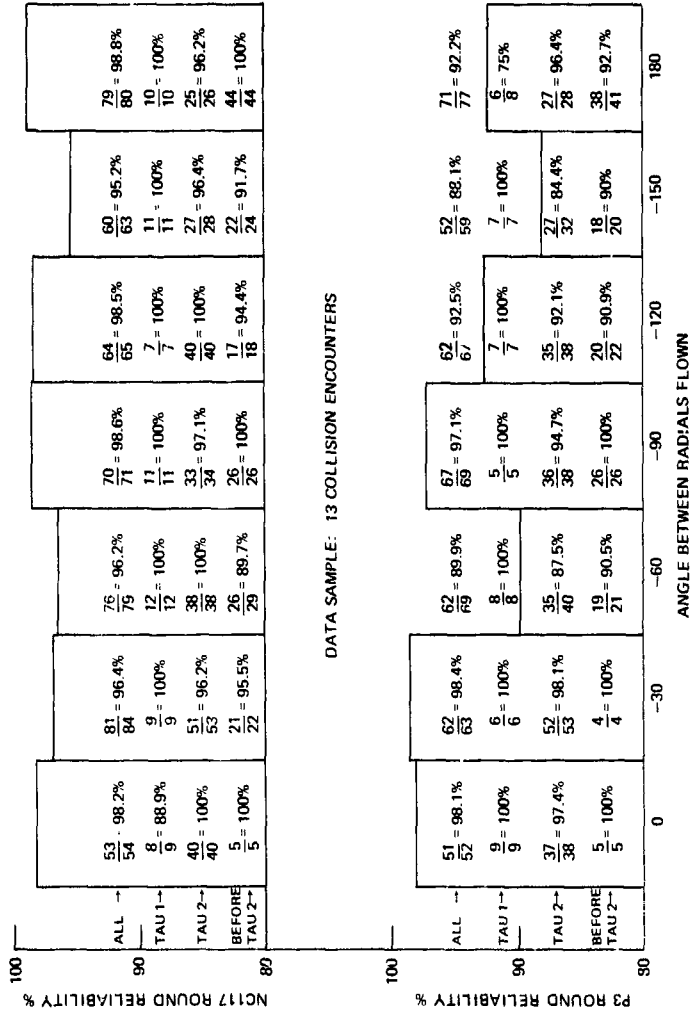
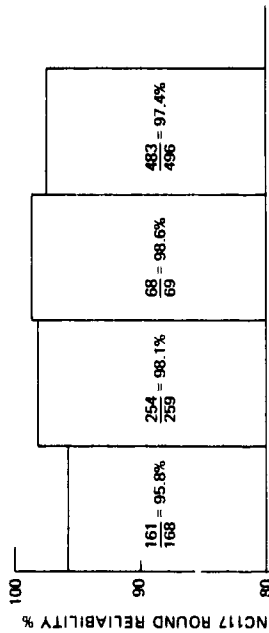
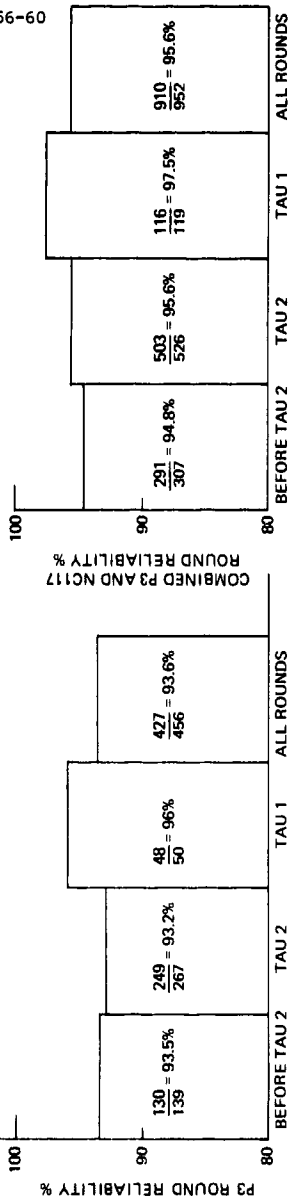

Figure VI-52. Round Reliability Versus Encounter Angle, Flight 7, NC-117 Above P-3A.



DATA SAMPLE: 13 COLLISION ENCOUNTERS



COMBINED P3 AND NC117

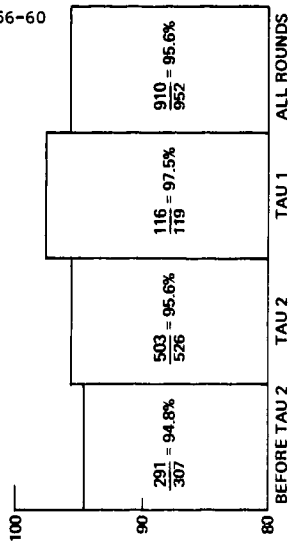

ROUND RELIABILITY BY ROUND TYPE  
WITHOUT REGARD TO ANGLE BETWEEN  
RADIALS FLOWN.  
FLIGHT 7 - 3 JULY 1974. SECOND HALF DAISY.  
P3 AT 9K FEET DIVING TO 8.6K FEET.  
NC117 AT 9.5K FEET CLIMBING TO 10K FEET.

FRUIT: 64K REPLIES/SEC  
1536 INT/SEC  
IN BOTH AIRCRAFT.  
6 db ATTENUATION IN THE RF LINK.

NADC-75056-60

Figure VI-53. Round Reliability, Flight 7, NC-117 Above P-3A.

DISPLAY RELIABILITY AS A FUNCTION OF THE ANGLE BETWEEN RADIALS FLOWN. FLIGHT 7 - 3 JULY 1974. SECOND HALF DAISY. P3 AT 9K FEET DIVING TO 8.6K FEET NC117 AT 9.5K TO 10K FEET.

FRUIT: 64K REPLIES/SEC 1536 INT/SEC IN BOTH AIRCRAFT. 6 db ATTENUATION IN THE RF LINK.

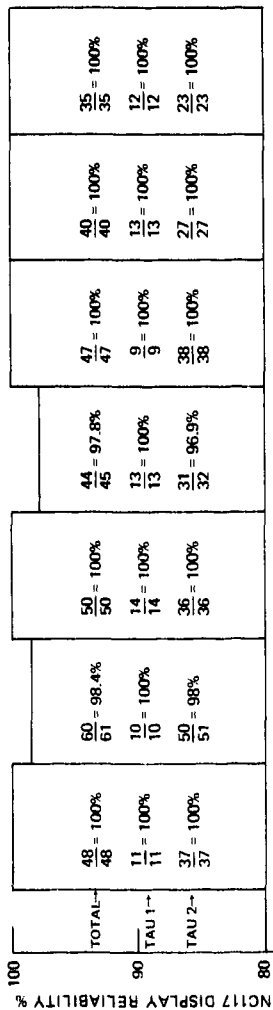

DATA SAMPLE: 13 COLLISION ENCOUNTERS

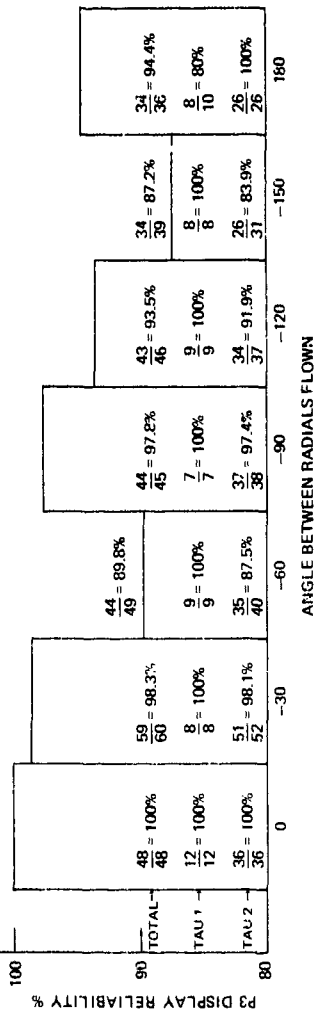

Figure VI-54, Display Reliability Versus Encounter Angle, Flight 7, NC-117 Above P-3A.

DISPLAY RELIABILITY WITHOUT REGARD  
TO ANGLE BETWEEN RADIALS FLOWN.  
FLIGHT 7 - 3 JULY 1974. SECOND HALF  
DAISY.  
P3 AT 9K FEET DIVING TO 8.6K FEET.  
NC117 AT 9.5K FEET CLIMBING TO 10K FEET.  
FRUIT: 64K REPLIES/SEC  
1536 INT/SEC  
IN BOTH AIRCRAFT.  
6 db ATTENUATION IN THE RF LINK.

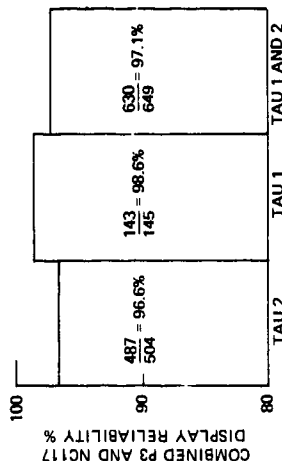
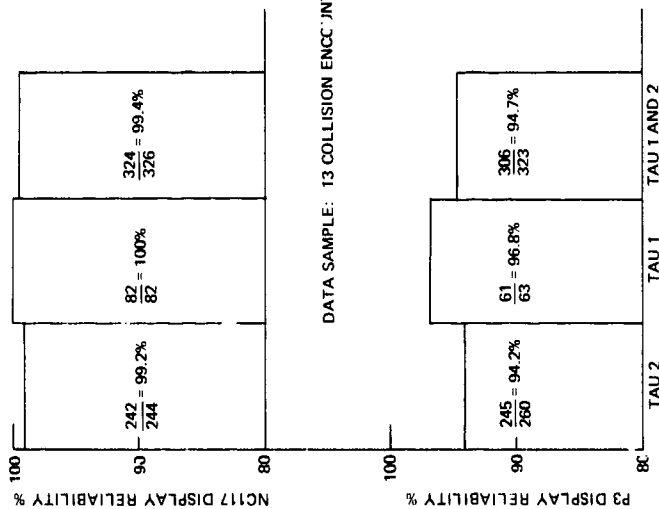
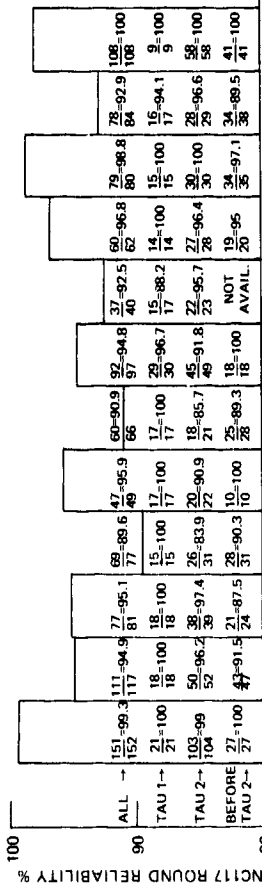

Figure VI-55. Display Reliability, Flight 7, NC-117 Above P-3A.

ROUND RELIABILITY FROM  
START OF USABLE  
COMMUNICATION TO END  
OF THREAT, AS A FUNCTION  
OF THE ANGLE BETWEEN  
RADIALS.  
FLIGHT 9 - 17 JULY 1974.  
3-AIRCRAFT ENCOUNTER  
RA3B ABOVE P3 NOT SHOWN.  
P3 AT 10.5K FEET  
NC117 AT 10K FEET DIVING  
TO 9.5K FEET

FRUIT: 32K REPLIES/SEC  
1536 INT/SEC  
IN BOTH AIRCRAFT.  
9 db ATTENUATION IN  
THE RF LINK.



DATA SAMPLE: 26 COLLISION ENCOUNTERS

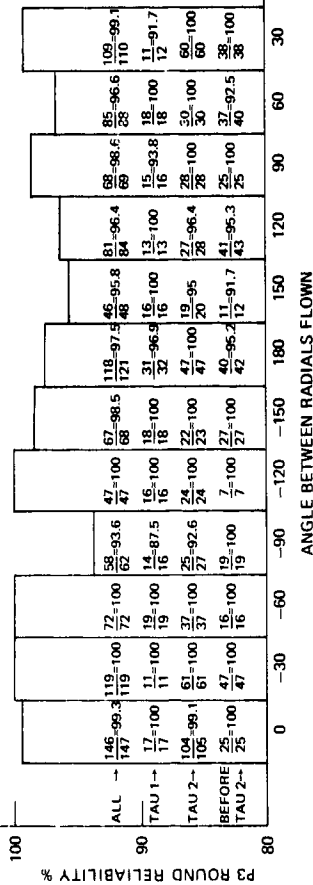

Figure VI-56. Round Reliability Versus Encounter Angle, Flight 9, P-3A Above NC-117.

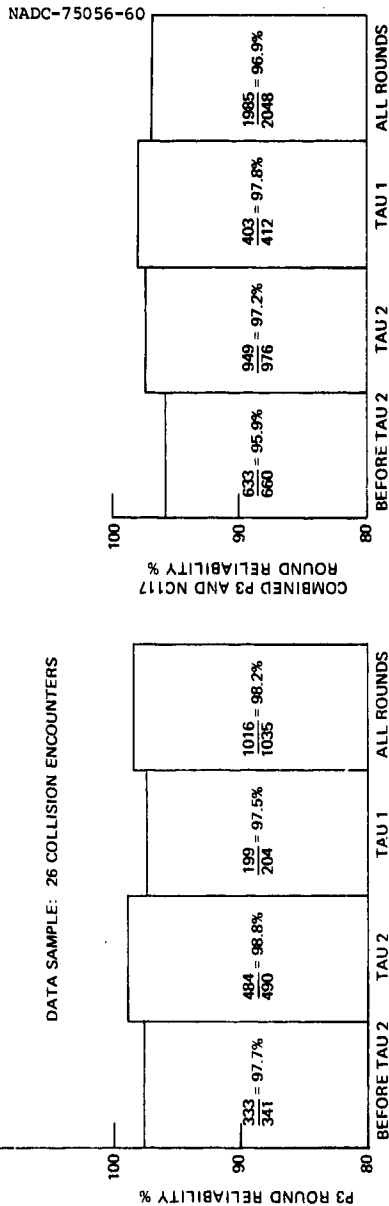
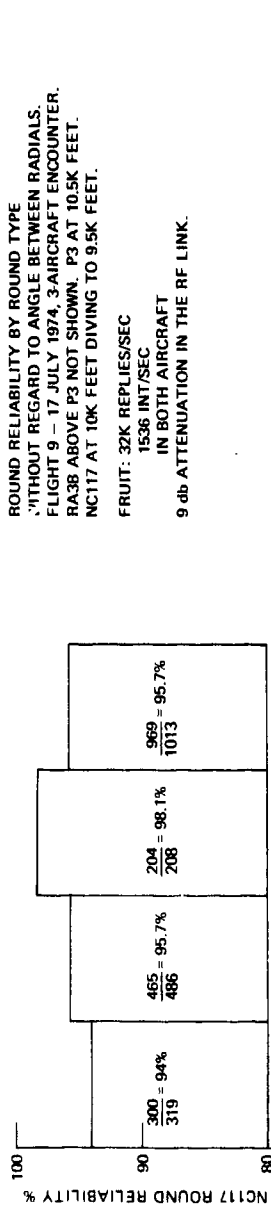

Figure VI-57. Round Reliability, Flight 9, F-3A Above NC-117.

Figure VI-58 shows the display reliability for the P-3 above the NC-117 for flight 9, with the lowest total Tau 1 and Tau 2 display reliability being 93 percent in the NC-117 at the  $-90^\circ$  encounter angle, indicating an improvement in display reliability over round reliability by the 2 out of 3 display logic rules. Most of the other display reliabilities were 100 percent. It is therefore not surprising that Figure VI-59, which depicts the display reliability without regard to the angle between radials flown, shows a combined P-3, NC-117 Tau 1 and Tau 2 display reliability of 99.4 percent. Again, it should be remembered that this good reliability was obtained with 9 db attenuation in the RF link.

Roughly similar results were obtained for the round and display reliability results of the second 3-aircraft encounter, flight 11, on 26 July 1974. The P-3 flew at 10,800 feet with the A-3 above and the NC-117 below at 10,000 feet diving to 9600 feet for most of the encounter angles. The NC-117 flew at 9800 feet for the  $-150^\circ$  and  $180^\circ$  encounter. Once more, there was 9 db attenuation in the link between the P-3 and the NC-117. The round reliability results as a function of the angle between radials flown are shown in Figure VI-60, with the lowest "all rounds" reliability being 90.3 percent in the NC-117 at an encounter angle of  $-60^\circ$ . The round reliability without regard to angle between radials flown is shown in Figure VI-61. The combined P-3 and NC-117 "all rounds" reliability shown in the lower right-hand corner of the figure is 94.3 percent. The display reliability as a function of the angle between radials flown for flight 11 is shown in Figure VI-62. The lowest total Tau 1 and Tau 2 display reliability is 90.2 percent in the NC-117 at an encounter angle of  $-90^\circ$ .

This flight illustrates another variable in the number of possible displays in each aircraft. Slight differences in round time can add up to unequal display opportunities in each aircraft. For most of this flight, the NC-117 round time was approximately 0.14 second longer than that of the P-3, resulting in fewer NC-117 displays for the same threat duration interval.

The display reliability without regard to the angle between radials flown for flight 11 is shown in Figure VI-63. The lower right-hand corner shows the combined P-3, NC-117 Tau 1 and Tau 2 display reliability as 95.9 percent once more with 9 db attenuation in the RF link.

For a better overview of the round and display reliability results involving the P-3 and NC-117 aircraft, a few summary graphs are included. The combined P-3 and NC-117 display reliability as a function of the angle between radials for the 3-aircraft encounter flights 9 and 11 on 17 and 26 July 1974 is shown in Figure VI-64. The negative encounter angles on the bottom are matched with the corresponding positive encounter angles on the top for ease of comparison. All of the positive encounter angles with the exception of  $180^\circ$  had a display reliability of 100 percent. The worst Tau 1 and Tau 2 display reliability was 93.6 percent at the  $-90^\circ$  encounter angle. The combined P-3, NC-117 display reliability without regard to the angle

DISPLAY RELIABILITY AS A FUNCTION OF THE ANGLE BETWEEN RADIALS FLOWN. FLIGHT 9 - 17 JULY 1974. 3-AIRCRAFT ENCOUNTER, RA3B ABOVE P3 NOT SHOWN. P3 AT 10.5K FEET. NC117 AT 10K FEET. DIVING TO 9.5K FEET. FRUIT: 32K REPLIES/SEC 1536 INT/SEC IN BOTH AIRCRAFT. 9 db ATTENUATION IN THE RF LINK.

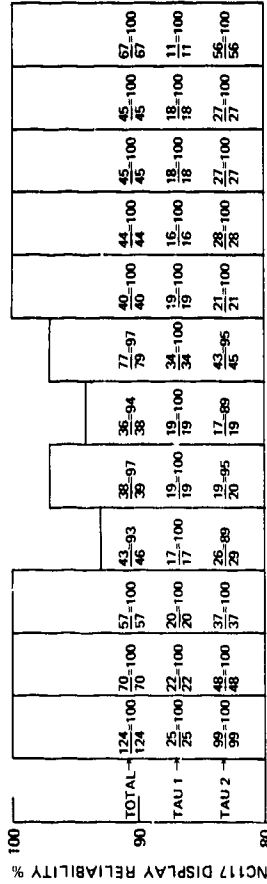

DATA SAMPLE: 26 COLLISION ENCOUNTERS

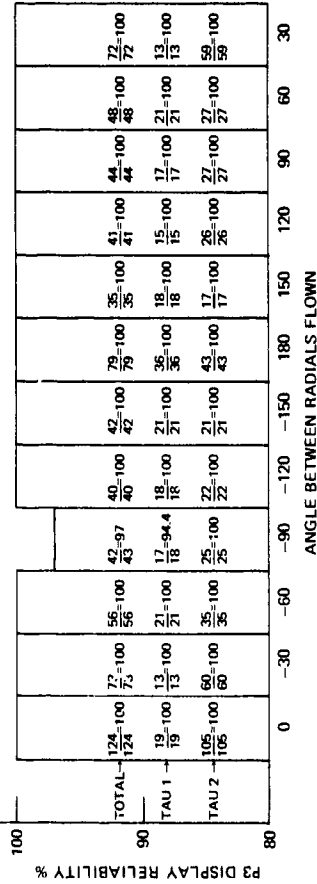

Figure VI-58. Display Reliability Versus Encounter Angle, Flight 9, P-3A Above NC-117.

DISPLAY RELIABILITY WITHOUT REGARD TO ANGLE BETWEEN RADIALS FLOWN.  
 FLIGHT 9 - 17 JULY 1974. 3-AIRCRAFT ENCOUNTER.  
 RA3B ABOVE P3 NOT SHOWN.  
 P3 AT 10.5K FEET. NC117 AT 10K FEET DIVING TO 9.5K FEET.  
 FRUIT: 32K REPLIES/SEC  
 1536 INT/SEC  
 IN BOTH AIRCRAFT.  
 9 db ATTENUATION IN THE RF LINK.

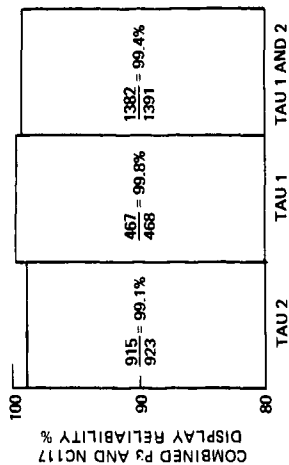
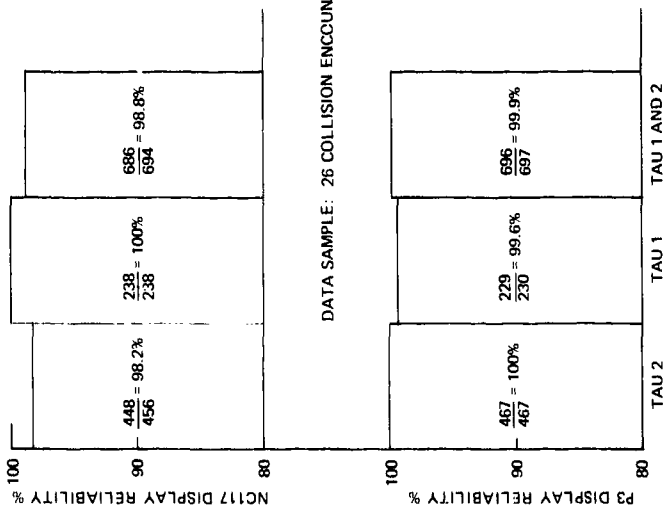

Figure VI-59. Display Reliability, Flight 9, P-3A Above NC-117.

ROUND RELIABILITY FROM START OF USABLE COMMUNICATION RANGE TO END OF THREAT, AS A FUNCTION OF THE ANGLE BETWEEN RADIALS FLOWN. FLIGHT 11 - 26 JULY 1974. 3-AIRCRAFT ENCOUNTER. RA38 ABOVE P3 NOT SHOWN. P3 AT 10.8K FEET. NC117 AT 9.8K FEET FOR 180° AND -150° ANGLES. NC117 AT 10K FEET DIVING TO 9.5K FEET FOR ALL OTHER ANGLES.

FRUIT: 32K REPLIES/SEC 1536 INT/SEC IN BOTH AIRCRAFT. 9 db ATTENUATION IN THE RF LINK.

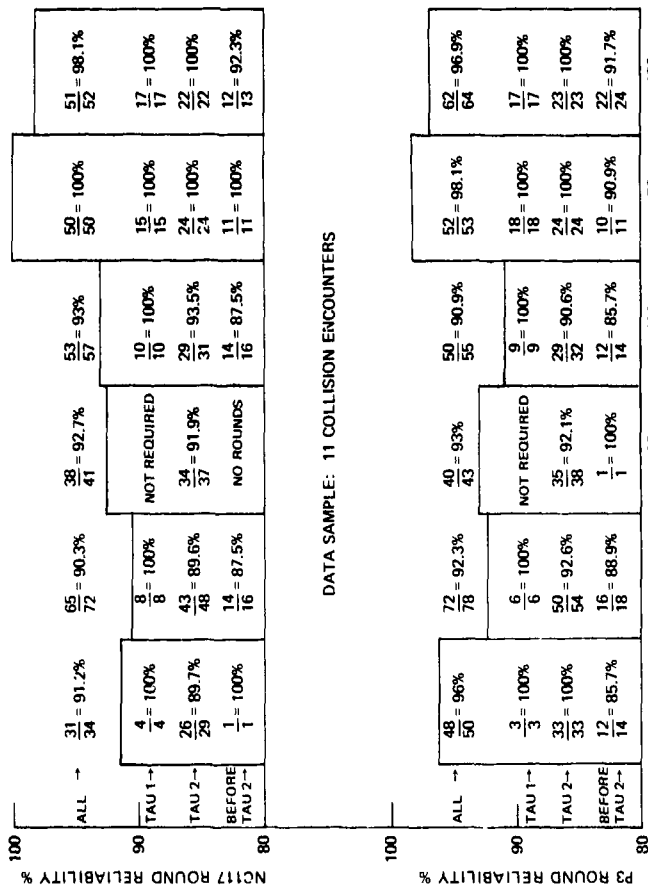
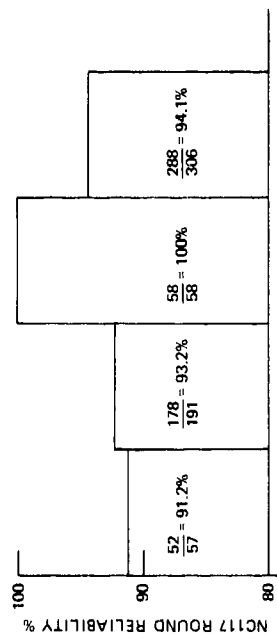

Figure VI-60. Round Reliability Versus Encounter Angle, Flight 11, P-3A Above NC-117.

ROUND RELIABILITY BY ROUND TYPE  
 WITHOUT REGARD TO ANGLE BETWEEN  
 RADIALS FLOWN. FLIGHT 11 - 26 JULY 1974.  
 3-AIRCRAFT ENCOUNTER, RA3B ABOVE P3  
 NOT SHOWN. P3 AT 10.8K FEET.  
 NC117 AT 9.8K FEET FOR 4 ENCOUNTERS.  
 NC117 AT 10K FEET DIVING TO 9.5K FEET  
 FOR ALL OTHER ENCOUNTERS.  
 FRUIT: 32K REPLIES/SEC  
 1536 INT/SEC  
 IN BOTH AIRCRAFT.  
 9 db ATTENUATION IN THE RF LINK.



DATA SAMPLE: 11 COLLISION ENCOUNTERS

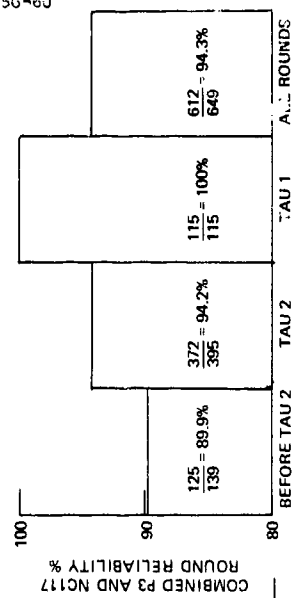
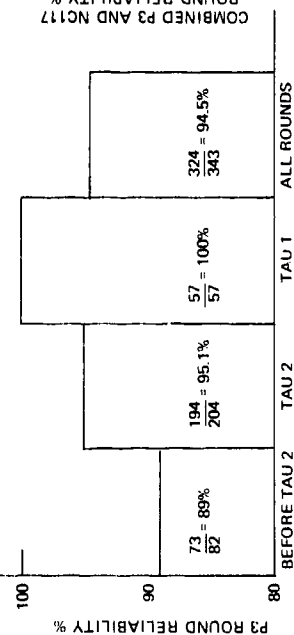

Figure VI-61. Round Reliability, Flight 11, P-3A Above NC-117.

DISPLAY RELIABILITY AS A FUNCTION OF THE ANGLE BETWEEN RADIALS FLOWN. FLIGHT 11 JULY 26, 1974. 3-AIRCRAFT ENCOUNTER, WITH P3 ABOVE P3 NOT SHOWN. P3 AT 10.8K FEET. NC117 AT 9.8K FEET FOR 180° AND -150° ENCOUNTERS. NC117 AT 10K DIVING TO 9.5K FEET FOR ALL OTHER ENCOUNTERS. FRUIT: 32K REPLIES/SEC 1536 INT/SEC IN BOTH AIRCRAFT. 9 db ATTENUATION IN THE RF LINK.

DATA SAMPLE: 11 COLLISION ENCOUNTERS

ANGLE BETWEEN RADIALS FLOWN (DEGREES)	30	60	90	120	150	180
TOTAL	28 = 90.3% 31	50 = 90.5% 55	37 = 90.2% 41	42 = 100% 42	40 = 100% 40	39 = 100% 39
TAU 1	5 = 100% 5	10 = 100% 10	5 = 100% 5	12 = 100% 12	17 = 100% 17	19 = 100% 19
TAU 2	23 = 88.5% 26	40 = 88.9% 45	32 = 85.9% 36	30 = 100% 30	23 = 100% 23	20 = 100% 20

ANGLE BETWEEN RADIALS FLOWN (DEGREES)	30	60	90	120	150	180
TOTAL	36 = 100% 36	56 = 94.9% 59	39 = 92.9% 42	39 = 92.9% 42	42 = 100% 42	40 = 100% 40
TAU 1	4 = 100% 4	8 = 100% 8	5 = 100% 5	11 = 100% 11	20 = 100% 20	19 = 100% 19
TAU 2	32 = 100% 32	48 = 94.1% 51	34 = 91.9% 37	28 = 90.3% 31	22 = 100% 22	21 = 100% 21

Figure VI-62. Display Reliability Versus Encounter Angle, Flight 11, P-3A Above NC-117.

DISPLAY RELIABILITY WITHOUT REGARD TO  
 ANGLE BETWEEN RADIALS FLOWN. FLIGHT 11,  
 26 JULY 1974. 3-AIRCRAFT ENCOUNTER, WITH  
 RA3B ABOVE THE P3 NOT SHOWN.  
 P3 AT 10.8K FEET. NC117 AT 9.8K FEET FOR  
 4 ENCOUNTERS. NC117 AT 10K, DIVING TO  
 9.5K FEET FOR ALL OTHER ENCOUNTERS.  
 FRUIT: 32K REPLIES/SEC  
 1536 INT/SEC  
 IN BOTH AIRCRAFT  
 9 db ATTENUATION IN THE RF LINK

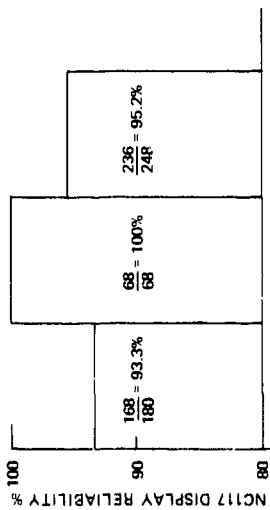

DATA SAMPLE: 11 COLLISION ENCOUNTERS

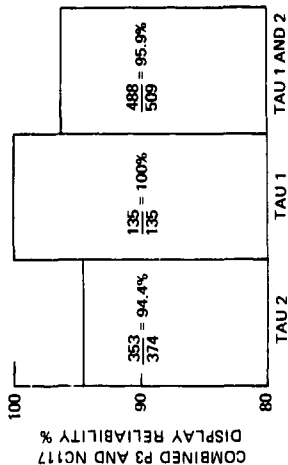
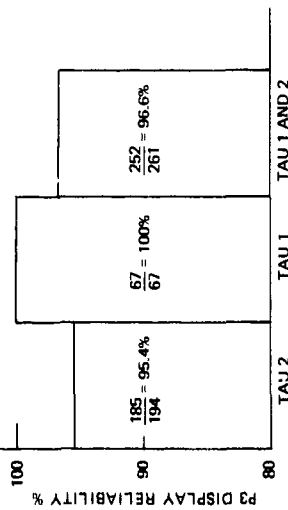

Figure VI-63. Display Reliability, Flight 11, P-3A Above NC-117.

DATA SAMPLE: 37 COLLISION ENCOUNTERS

COMBINED P3 AND NC117 DISPLAY RELIABILITY %	ANGLE BETWEEN RADIALS FLOWN (DEGREES)					
	30	60	90	120	150	180
TOTAL	$\frac{139}{139} = 100\%$	$\frac{93}{93} = 100\%$	$\frac{89}{89} = 100\%$	$\frac{85}{85} = 100\%$	$\frac{75}{75} = 100\%$	$\frac{235}{237} = 99.2\%$
TAU 1	$\frac{24}{24} = 100\%$	$\frac{29}{39} = 100\%$	$\frac{35}{35} = 100\%$	$\frac{31}{31} = 100\%$	$\frac{37}{37} = 100\%$	$\frac{108}{108} = 100\%$
TAU 2	$\frac{115}{115} = 100\%$	$\frac{54}{54} = 100\%$	$\frac{54}{54} = 100\%$	$\frac{54}{54} = 100\%$	$\frac{38}{38} = 100\%$	$\frac{127}{129} = 98.4\%$

COMBINED P3 AND NC117 DISPLAY RELIABILITY AS A FUNCTION OF THE ANGLE BETWEEN RADIALS. FLIGHTS 9 AND 11 - 17 AND 26 JULY 1974. P3 500 TO 800 FEET ABOVE NC117 WITH EVASIVE MANEUVERS INCREASING SEPARATION TO AS MUCH AS 1300 FEET. BOTH AIRCRAFT ABOVE 10K FEET. 9 db ATTENUATION IN THE RF LINK.

FRUIT: 32K REPLIES/SEC  
1536 INT/SEC  
IN BOTH AIRCRAFT.

ANGLE BETWEEN RADIALS FLOWN (DEGREES)

COMBINED P3 AND NC117 DISPLAY RELIABILITY %	ANGLE BETWEEN RADIALS FLOWN (DEGREES)					
	-30	-60	-90	-120	-150	0
TOTAL	$\frac{207}{210} = 98.6\%$	$\frac{219}{227} = 96.5\%$	$\frac{161}{172} = 93.6\%$	$\frac{159}{163} = 97.5\%$	$\frac{160}{162} = 98.8\%$	$\frac{248}{248} = 100\%$
TAU 1	$\frac{44}{44} = 100\%$	$\frac{59}{59} = 100\%$	$\frac{44}{45} = 97.8\%$	$\frac{60}{60} = 100\%$	$\frac{77}{77} = 100\%$	$\frac{44}{44} = 100\%$
TAU 2	$\frac{163}{166} = 98.2\%$	$\frac{160}{168} = 95.2\%$	$\frac{117}{127} = 92.1\%$	$\frac{99}{103} = 96.1\%$	$\frac{83}{85} = 97.6\%$	$\frac{204}{204} = 100\%$

ANGLE BETWEEN RADIALS FLOWN (DEGREES)

Figure VI-64. Display Reliability Versus Encounter Angle, Flights 9 and 11, P-3A Above NC-117.

between radials flown for flights 9 and 11 is shown in Figure VI-65. The combined Tau 1 and Tau 2 display reliability is shown as 98.4 percent with 9 db attenuation in the RF link, and fruit consisting of 32,000 replies per second and 1536 interrogation quads per second in each aircraft.

A more complete combined P-3, NC-117 display reliability summary graph as a function of the angle between radials flown is shown in Figure VI-66. Here, the results of flight 6 with no attenuation, and the first half of flight 7 with 6 db attenuation, are combined with the previously summarized flights 9 and 11 with 9 db of attenuation to give even better display reliability. The worst total Tau 1 and Tau 2 display reliability is now raised to 95.9 percent at the  $-90^\circ$  encounter angle. The combined P-3, NC-117 display reliability without regard to the angle between radials flown for these flights is shown in Figure VI-67 as a Tau 1 and Tau 2 display reliability of 98.8 percent. This was determined from a total of 63 collision encounters as 3079 successes out of 3117 recorded attempts.

Figure VI-68 shows the combined P-3, NC-117 round reliability without regard to the angle between radials flown. In addition to the previous flights summarized above 10,000 feet with the P-3 above the NC-117, this graph contains the results of the second half of flight 7 below 10,000 feet with the NC-117 above the P-3. The "all rounds" reliability was 96.8 percent.

The final summary graph for this section is Figure VI-69. This is the combined P-3, NC-117 display reliability without regard to the angle between radials flown for all of the P-3 versus NC-117 flights of this section. It shows the results of 76 collision encounters as 98 percent for the Tau 2 display reliability and 99.7 percent for the Tau 1 display reliability, or 98.5 percent for all displays.

#### RELIABILITY - RA-3B VERSUS NC-117 FLIGHTS

This section discusses the round and display reliability results for the flights involving the A-3 and the NC-117 aircraft. Since these two aircraft were involved with each other only as part of the 3-aircraft encounter flights, the only data available is from flights 9 and 11, with the A-3 above the NC-117 and all of the encounters being at  $-90^\circ$ .

Figure VI-70 for flight 9 on 17 July 1974 shows the round reliability at  $-90^\circ$ , with the RA-3B at 11,000 feet climbing to 12,000 feet because of the climb commands it received from the P-3 below it, and the NC-117 at 10,000 feet diving to 9500 feet because of the dive commands from the P-3 above it. Both the A-3 and the NC-117 detected each other as lesser threats while reacting to the more severe threat of the P-3 flying midway between them in altitude. The A-3 round reliability is shown on the bottom, and the NC-117 round reliability is shown on top. The combined P-3 and NC-117 round reliability is shown

COMBINED P3 AND NC117 DISPLAY  
 RELIABILITY WITHOUT REGARD TO  
 ANGLE BETWEEN RADIALS.  
 FLIGHTS 9 AND 11 17 AND 26 JULY 1974.  
 P3 500 TO 800 FEET ABOVE NC117 WITH  
 EVASIVE MANEUVERS INCREASING  
 SEPARATION TO AS MUCH AS 1300 FEET.  
 BOTH AIRCRAFT ABOVE 10K FEET.  
 9 db ATTENUATION IN THE RF LINK.

FRUIT: 32K REPLIES/SEC  
 1536 INT/SEC  
 IN BOTH AIRCRAFT

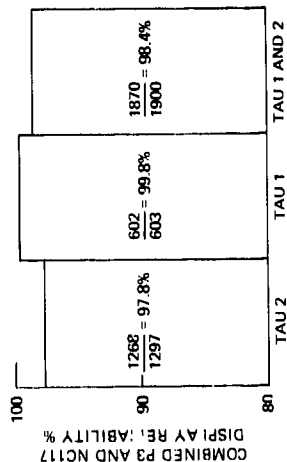

Figure VI-65. Display Reliability, Flights 9 and 11, P-3A Above NC-117.

COMBINED P3 AND NC117  
 DISPLAY RELIABILITY AS  
 A FUNCTION OF THE  
 ANGLE BETWEEN RADIALS.  
 FLIGHTS 6 (0 db), 7  
 1ST HALF DAISY POSITIVE  
 ANGLES (6 db), 9 AND  
 11 (9 db), 1, 3, 17, 26 JULY  
 1974.  
 P3 500 TO 1400 FEET  
 ABOVE THE NC117. BOTH  
 AIRCRAFT ABOVE 10K FEET.  
 FRUIT AT LEVELS SHOWN  
 ON GRAPHS FOR EACH  
 FLIGHT.

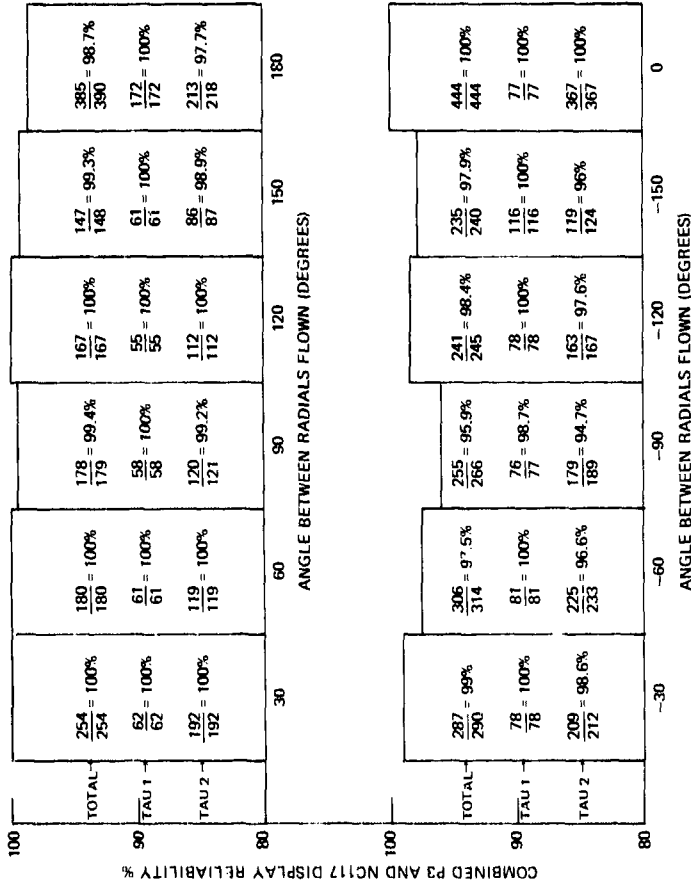

Figure VI-66. Display Reliability Versus Encounter Angle, Flights 6, 7 (Part), 9 and 11, P-3A Above NC-117.

COMBINED P3 AND NC117 DISPLAY  
 RELIABILITY WITHOUT REGARD TO ANGLE  
 BETWEEN RADIALS FLOWN.  
 FLIGHTS 6 (0 db), 7 1ST HALF DAISY  
 POSITIVE ANGLES (6 db), 9 AND 11 (9 db).  
 1, 3, 17, 26, JULY 1974.  
 P3 500 TO 1400 FEET ABOVE THE NC117.  
 BOTH AIRCRAFT ABOVE 10K FEET.  
 FRUIT AT LEVELS SHOWN ON GRAPHS FOR  
 EACH FLIGHT.

DATA SAMPLE: 63 COLLISION ENCOUNTERS

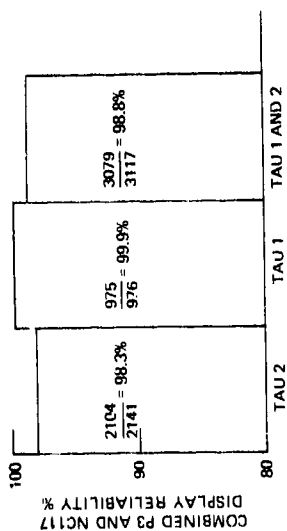

Figure VI-67. Display Reliability, Flights 6, 7 (Part), 9 and 11, P-3A Above NC-117.

COMBINED P3 AND NC117 ROUND  
 RELIABILITY WITHOUT REGARD TO  
 ANGLE BETWEEN RADIALS FLOWN.  
 FLIGHTS 6 (0 db), 7 (6 db), 9 AND 11 (9 db).  
 1, 3, 17, 26 JULY 1974

FLIGHT 6 14 ENCOUNTERS ABOVE 10K FEET  
 7 12 ENCOUNTERS ABOVE 10K FEET  
 9 13 ENCOUNTERS BELOW 10K FEET  
 11 26 ENCOUNTERS ABOVE 10K FEET  
 11 11 ENCOUNTERS ABOVE 10K FEET

DATA SAMPLE: 76 COLLISION ENCOUNTERS

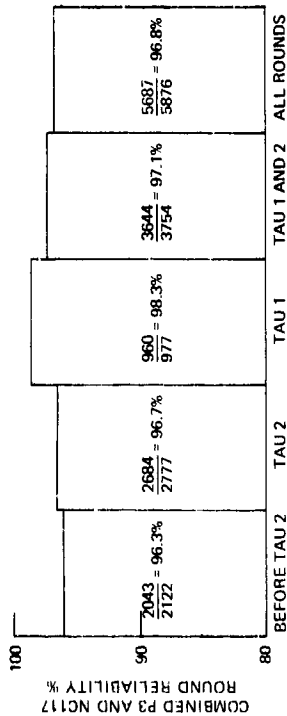

Figure VI-68. Total Round Reliability, Flights 6, 7, 9 and 11, P-3A Versus NC-117.

COMBINED P3 AND NC117 DISPLAY RELIABILITY WITHOUT REGARD TO ANGLE BETWEEN RADIALS FLOWN. FLIGHTS 6 (0 db), 7 (6 db), 9 AND 11 (9 db). 1, 3, 17, 26 JULY 1974.

SECOND HALF OF FLIGHT 7 WAS WITH THE NC117 500 FEET ABOVE THE P3 WITH EVASIVE MANEUVERS RESULTING IN AS MUCH AS 1400 FEET SEPARATION. BOTH AIRCRAFT WERE BELOW 10K FEET. ALL OTHER FLIGHTS WERE WITH THE P3 ABOVE THE NC117 AND WITH BOTH AIRCRAFT ABOVE 10K FEET. FRUIT VALUES ARE AS SHOWN ON THE GRAPHS OF EACH FLIGHT.

DATA SAMPLE: 76 COLLISION ENCOUNTERS

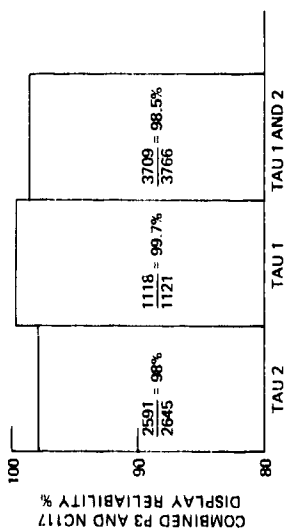
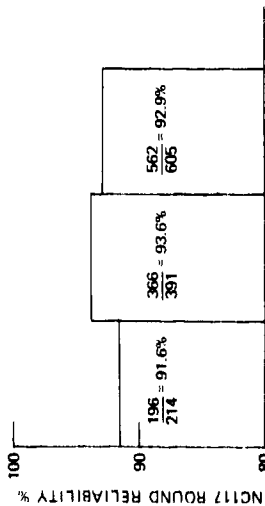

Figure VI-69. Total Display Reliability, Flights 6, 7, 9 and 11, P-2A Versus NC-117.

ROUND RELIABILITY FROM START OF USABLE COMMUNICATION TO END OF THREAT FOR AN ANGLE BETWEEN RADIALS FLOWN OF MINUS 90 DEG. FLIGHT 9, 17 JULY 1974.  
 3-AIRCRAFT ENCOUNTER, WITH P3 IN THE MIDDLE NOT SHOWN.  
 RA3B AT 11K FEET CLIMBING TO 12K FEET.  
 NC-17 AT 10K FEET DIVING TO 9.5K FEET.  
 FRUIT: A3 32K REPLIES/SEC  
 1200 INT/SEC  
 NC117 32K REPLIES/SEC  
 1536 INT/SEC  
 3 db ATTENUATION IN THE RF LINK.



DATA SAMPLE: 26 COLLISION ENCOUNTERS

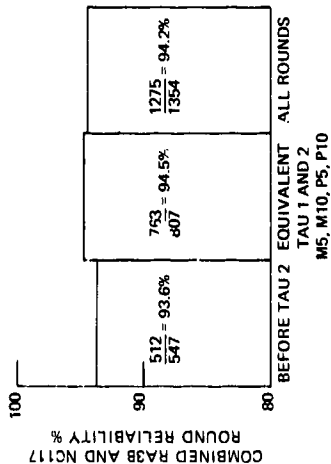
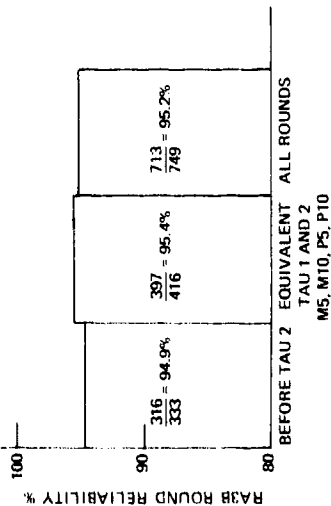

Figure VI-70. Round Reliability, Flight 9, RA-3B Above NC-117, -90° Encounters.

at the bottom right, with the "all rounds" reliability being 94.2 percent with 3 db of external attenuation in the RF link. The rounds classified as Tau 1 and Tau 2 rounds were actually M5, M10, P5, and P10 rounds limiting rates of descent and climb to 500 and 1000 feet per minute, respectively.

The display reliability for this same flight 9, shown in Figure VI-71, was 98.8 percent for the A-3, 97.6 percent for the NC-117, and 98.2 percent for both aircraft combined.

The round reliability for flight 11 with 3 db attenuation in the RF link is shown in Figure VI-72, with a combined A-3, NC-117 "all rounds" reliability of 95.3 percent. Since the NC-117 did not interrogate P10 threats (above 1300 feet) when it was switched to normal mode (for the sake of obtaining normal operation with the P-3 aircraft), less NC-117 rounds in which it was possible for it to display the A-3 threat were recorded; i.e., 193 rounds compared to 273 rounds recorded in the A-3, which was left in the unrestricted mode of operation.

The display reliability for flight 11 with 3 db attenuation is shown in Figure VI-73. The equivalent Tau 1 and Tau 2 display reliability for the A-3 was 99.1 percent, and for the NC-117 it was 98.3 percent. The combined A-3 and NC-117 display reliability was 99 percent.

Two summary reliability graphs are included here for the flights involving the A-3 and the NC-117. The first is Figure VI-74, which shows the combined A-3 and NC-117 round reliability for flights 9 and 11, both with 3 db attenuation in the RF link. This shows a combined "all rounds" reliability of 94.5 percent. The second is Figure VI-75, which shows the combined A-3 and NC-117 equivalent Tau 1 and Tau 2 display reliability for these two flights as 98.4 percent. Even though these results are limited to  $-90^\circ$  encounters, they are consistent with similar good results obtained from P-3 versus NC-117 flights over many different encounter angles.

#### SUMMARY

##### 1. COMMUNICATION RANGE

All flights involving the NC-117 versus either the P-3 or RA-3B had sufficient communication range to insure the required Tau 2 warning times at all collision encounter angles flown. The encounter angles were flown in steps of  $30^\circ$ . When extrapolated to higher speed encounters above 10,000 feet involving two 600-knot aircraft, the average power margins ranged between 4.1 and 8.6 db, depending on the encounter angle. For the speeds flown, the margins were correspondingly greater. Figure VI-20 is a composite of the combined average P-3 and NC-117 communication range as a function of the angle between radials flown. Figure VI-21 is a scatter graph composite for

DISPLAY RELIABILITY FOR AN ANGLE  
 BETWEEN RADIALS FLOWN OF MINUS  
 90 DEG. FLIGHT 9, 17 JULY 1974.  
 3-AIRCRAFT ENCOUNTER, WITH P3  
 IN THE MIDDLE NOT SHOWN. RA3B AT  
 11K FEET CLIMBING TO 12K FEET.  
 NC117 AT 10K FEET DIVING TO 9.5K FEET.

FRUIT: A3 32K REPLIES/SEC  
 1200 INT/SEC  
 NC117 32K REPLIES/SEC  
 1536 INT/SEC  
 3 db ATTENUATION IN THE RF LINK.

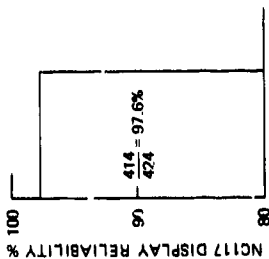

DATA SAMPLE: 26 COLLISION ENCOUNTERS

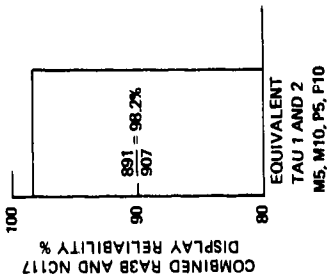
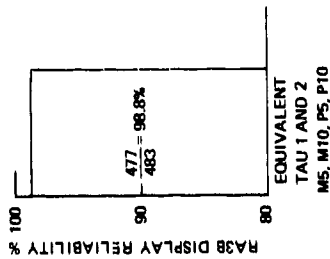

Figure VI-71. Display Reliability, Flight 9, RA-3B Above NC-117, - 90° Encounters.

ROUND RELIABILITY FROM START OF  
 USABLE COMMUNICATION TO END OF THREAT  
 FOR AN ANGLE BETWEEN RADIALS FLOWN  
 OF MINUS 90 DEG. FLIGHT 11, 26 JULY 1974.  
 3-AIRCRAFT ENCOUNTER, WITH P3 IN THE  
 MIDDLE NOT SHOWN. RA38 AT 11.8K FEET,  
 NC117 AT 9.8K FEET FOR 4 ENCOUNTERS.  
 RA38 AT 11.5 TO 11.6K FEET, NC117 AT 10.1K  
 FEET DIVING TO 9.6K FEET FOR 7 ENCOUNTERS.  
 FRUIT: A3 NONE  
 NC117 32K REPLIES/SEC  
 1536 INT/SEC  
 3 db ATTENUATION IN THE RF LINK.

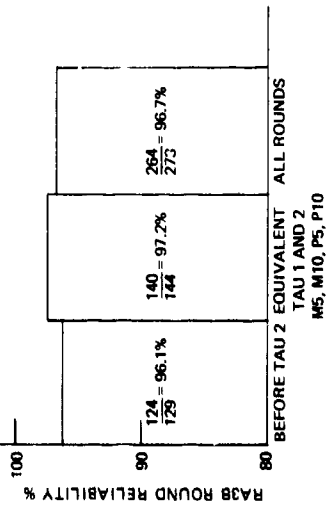
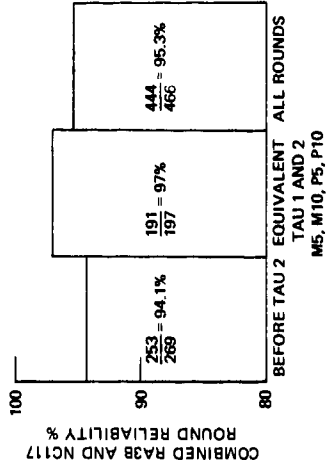
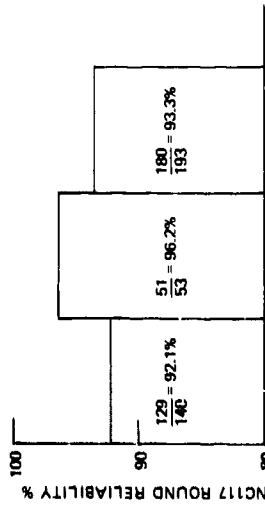

Figure VI-72. Round Reliability, Flight 11, RA-38 Above NC-117, -90° Encounters.

DISPLAY RELIABILITY FOR AN ANGLE BETWEEN RADIALS FLOWN OF MINUS 90 DEG. FLIGHT 11, 26 JULY 1974. 3-AIRCRAFT ENCOUNTER, WITH P3 IN THE MIDDLE NOT SHOWN.  
 RA3B AT 11.8K FEET, NC117 AT 9.8K FEET FOR 4 ENCOUNTERS.  
 RA3B AT 11.5 TO 11.6K FEET, NC117 AT 10.1K FEET DIVING TO 9.6K FEET FOR 7 ENCOUNTERS.

FRUIT: A3 NONE  
 NC117 32K REPLIES/SEC  
 1536 INT/SEC  
 3 db ATTENUATION IN THE RF LINK.

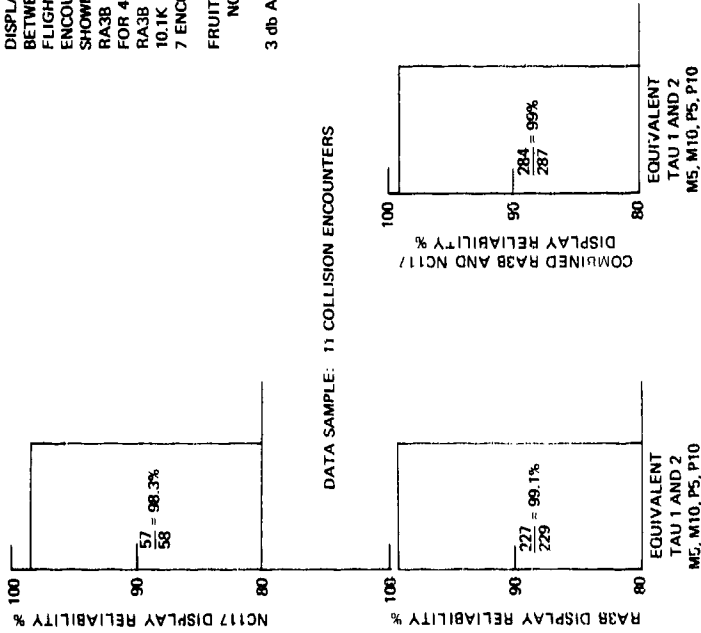

Figure VI-73. Display Reliability, Flight 11, RA-3B Above NC-117, -90° Encounters.

COMBINED RA3B AND NC117 ROUND RELIABILITY AT AN ANGLE OF MINUS 90 DEG BETWEEN RADIALS FLOWN, FLIGHTS 9 AND 11 - 17, 26 JULY 1974. 3-AIRCRAFT ENCOUNTERS, WITH THE P3 IN THE MIDDLE NOT SHOWN. RA3B 1K to 2K FEET ABOVE THE NC117. BOTH AIRCRAFT ABOVE 10K FEET. FRUIT AS SHOWN ON GRAPHS FOR EACH FLIGHT. 3 db ATTENUATION IN THE RF LINK.

DATA SAMPLE: 37 COLLISION ENCOUNTERS

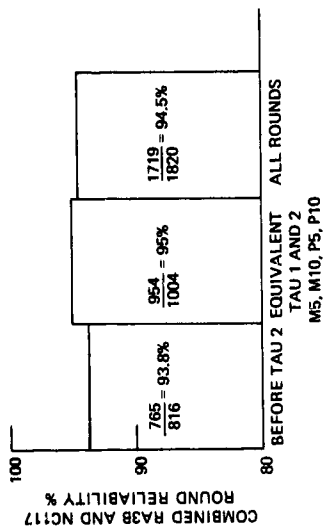

Figure VI-74. Total Round Reliability, Flights 9 and 11, RA-3B Above NC-117, -90° Encounters.

COMBINED RA3B AND NC117 DISPLAY RELIABILITY AT AN ANGLE OF MINUS 90 DEG BETWEEN RADIALS FLOWN. FLIGHTS 9 AND 11 - 17, 26 JULY 1974. 3-AIRCRAFT ENCOUNTERS, WITH THE P3 IN THE MIDDLE NOT SHOWN. RA3B 1K TO 2K FEET ABOVE THE NC117. BOTH AIRCRAFT ABOVE 10K FEET. FRUIT AS SHOWN ON GRAPHS FOR EACH FLIGHT. 3 db ATTENUATION IN THE RF LINK.

DATA SAMPLE: 37 COLLISION ENCOUNTERS

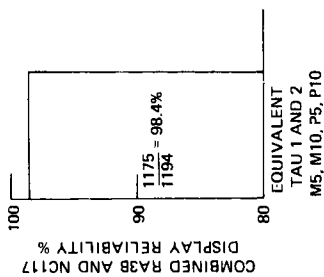

Figure VI-75. Total Display Reliability, Flights 9 and 11, RA-3B Above NC-117, -90° Encounters.

the A-3 and NC-117 communication range at the -90° encounter angle flown. The more than 2 to 1 variability in the ranges obtained from 32 collision encounters emphasizes the variety of antenna look angles obtained for the -90° encounter angle flown, due to variations in wind, heading, speed, etc., from one encounter to the next. In no case was there a failure to meet or exceed the 11.2 mile extrapolated, high-speed, 90° encounter angle communication range requirement.

The flights involving the RA-3B versus the P-3 had a greater than 6 db average communication range margin for all the encounter angles at the speeds flown. When extrapolated to higher speed encounters above 10,000 feet for two 600-knot aircraft, the power margins ranged between 1 and 6 db for most of the encounter angles, except for the case of the P-3 above the A-3 which was marginal at the -120° and 180° encounters. Figure VI-13 combines and averages the available communication range data for the P-3 flying above the A-3. Figure VI-14 similarly combines and averages the available communication range data for the A-3 flying above the P-3. The marginal average communication range for some extrapolated higher speed encounter angles indicates the need for optimizing antenna locations; however, in all cases, the important Tau 1 warning range requirement was well protected.

## 2. ROUND AND DISPLAY COMMUNICATION RELIABILITY

The round and display reliability were both satisfactory from the communication point of view. The total round reliability for all communication reliability flights, for all aircraft, and for all types of rounds was 95.9 percent, based on 11,213 three-second round opportunities. By round type, the reliability was 95.3 percent before Tau 2, 95.8 percent for Tau 1, 97.8 percent for Tau 1, and 96.3 percent for combined Tau 1 and Tau 2 rounds. These reliabilities are shown on the total round reliability graph of Figure VI-76.

The total display reliability for all communication reliability flights, for all aircraft, and for all Tau 1 and Tau 2 displays was 98.2 percent, based on 7373 three-second display opportunities. By display type, the reliability was 97.7 percent for Tau 2 and 99.7 percent for Tau 1. These reliabilities are shown on the total display reliability graph of Figure VI-77. The approximate 1.9 percent improvement in combined Tau 1 and Tau 2 display reliability, compared to the combined Tau 1 and Tau 2 round reliability, was due to the use of a 2 out of 3 display acquisition and retention logic for threats within 1300 feet of altitude.

Significantly, the following reliability figures were obtained from 168 collision encounters, of which 55 had no additional RF attenuation, 37 had 3 db of additional RF attenuation, and 76 had 9 db of additional attenuation. All encounters had some fruit in either one or both aircraft yielding up to 64,000 replies per second and 1536 interrogation quads per second above threshold in each aircraft, without apparent receiver desensitization or excessive blocking.

TOTAL ROUND RELIABILITY FOR ALL COMMUNICATION RELIABILITY FLIGHTS AND FOR ALL AIRCRAFT  
 TYPE 1 - P3 VS. A3 FLIGHTS 4 (0 db), 9 AND 11 (6 db), 12 TAIL CHASES (3 db), 12 HEAD ON'S (0 db) - 57 ENCOUNTERS.  
 TYPE 2 - P3 VS. NC117 FLIGHTS 6 (0 db), 7 (6 db), 9 AND 11 (9 db) - 76 ENCOUNTERS.  
 TYPE 3 - A3 VS. NC117 FLIGHTS 9 AND 11 (3 db) - 37 ENCOUNTERS.  
 ALL TYPE 3 WARNING ROUNDS WERE CONSIDERED AS TAU 2 ROUNDS BECAUSE OF THE GREATER THAN 1K FEET ALTITUDE SEPARATION.

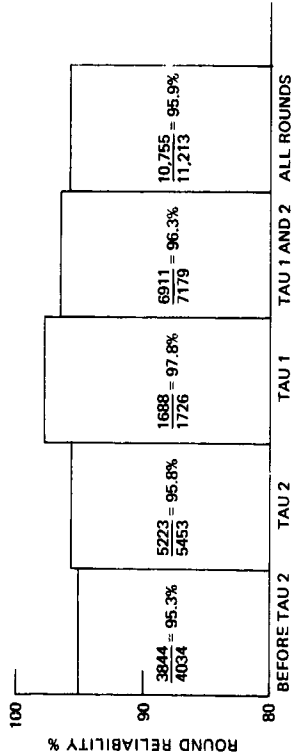

Figure VI-76. Total Round Reliability for all Communication Reliability Flights.

TOTAL DISPLAY RELIABILITY FOR ALL COMMUNICATION RELIABILITY FLIGHTS AND FOR ALL AIRCRAFT.

- TYPE 1 - P3 VS. A3 FLIGHTS 4 (0 db), 9 (6 db), 11 (6 db), 12 (0 db) - 55 ENCOUNTERS.
- TYPE 2 - P3 VS. NC117 FLIGHTS 6 (0 db), 7 (6 db), 9 AND 11 (9 db) - 76 ENCOUNTERS.
- TYPE 3 - A3 VS. NC117 FLIGHTS 9 AND 11 (3 db) - 37 ENCOUNTERS.

ALL TYPE 3 DISPLAYS WERE CONSIDERED AS TAU 2 DISPLAYS BECAUSE OF THE GREATER THAN 1K FEET ALTITUDE SEPARATION.

DATA SAMPLE: 168 COLLISION ENCOUNTERS

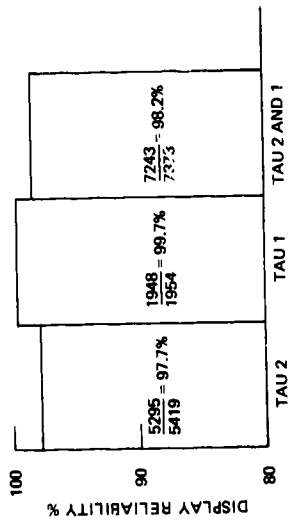

Figure VI-77. Total Display Reliability for all Communication Reliability Flights.

The total round reliability for all communication reliability flights involving the P-3 and A-3, for all types of rounds, was 95.2 percent. This is shown in Figure VI-78. The total Tau 1 and Tau 2 display reliability for all communication reliability flights involving the P-3 and A-3 was 97.8 percent, with the Tau 2 display reliability being 96.8 percent and the Tau 1 display reliability being 99.6 percent. This is shown in Figure VI-79.

The total round reliability for all communication reliability flights involving the P-3 and NC-117 for all types of rounds was 96.8 percent. This is shown in Figure VI-68.

The total Tau 1 and Tau 2 display reliability for all communication reliability flights involving the P-3 and NC-117 was 98.5 percent, with the Tau 2 display reliability being 98 percent and the Tau 1 display reliability being 99.7 percent. This is shown in Figure VI-69.

The total round reliability for all communication reliability flights involving the A-3 and NC-117 for all types of rounds was 94.5 percent. This is shown in Figure VI-74.

The total equivalent Tau 1 and Tau 2 display reliability for all communication reliability flights involving the A-3 and NC-117 was 98.4 percent.

COMBINED P3 AND A3 ROUND RELIABILITY  
 FOR ALL COMMUNICATION RELIABILITY  
 FLIGHTS OF P3 VS. A3. FLIGHTS 4, 9, 11, 12  
 - 24 APRIL; 17, 26, 29 JULY 1974, INCLUDES  
 3 AIRCRAFT ENCOUNTERS OF FLIGHTS 9 AND  
 11. FLIGHT 12 INCLUDES 2 TAIL CHASES OF  
 P3 BY A3, 2 OPENINGS OF A3 FROM P3 FOR  
 WHICH THERE ARE NO CORRESPONDING  
 DISPLAYS AND 5 HIGH-SPEED HEAD-ON  
 ENCOUNTERS.

ATTENUATION: FLIGHT 4 (0 db)  
 FLIGHTS 9 AND 11 (6 db)  
 FLIGHT 12 TAIL CHASES (3 db)  
 FLIGHT 12 HEAD-ON (0 db)

DATA SAMPLE: 57 COLLISION ENCOUNTERS

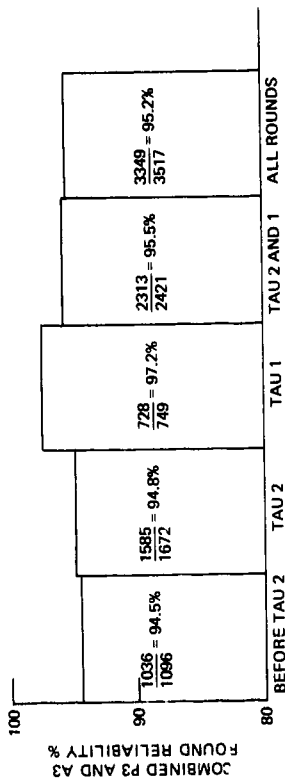

Figure VI-78. Total Round Reliability for all Communication Reliability Flights of P-3A Versus RA-3B.

GRAND TOTAL COMBINED P3 AND A3 PILOT  
 DISPLAY RELIABILITY FOR ALL  
 COMMUNICATION RELIABILITY FLIGHTS  
 OF P3 VS. A3 FLIGHTS 4, 9, 11, 12 —  
 24 APRIL; 17, 26, 29 JULY 1974, INCLUDES  
 3 AIRCRAFT ENCOUNTERS OF FLIGHTS  
 9 AND 11.

DATA SAMPLE: 55 COLLISION ENCOUNTERS

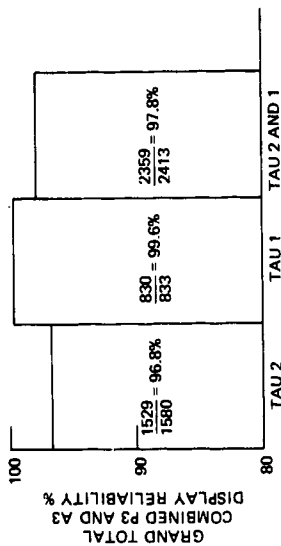

Figure VI-79. Total Display Reliability for all Communication Reliability Flights of P-3A Versus RA-3B.

## CHAPTER VII

## RANGE, RANGE RATE, AND WARNING TIME ACCURACIES

## INTRODUCTION

After initial debugging flights of the AVOID I were completed, collision encounters were flown over the NAVAIRTESTCEN (Naval Air Test Center) Chesapeake Theodolite Range to determine the accuracy with which the AVOID I measured range and range rate and the accuracy with which it gave Tau 2 and Tau 1 alarms.

Six theodolites strung out in a line along the bay provided a three-theodolite solution for the position of each aircraft of a two aircraft encounter. The real time on the aircraft via a precision oscillator was synchronized to the theodolite range via the same time source, WWV Boulder, Colorado.

In order to compare the aperiodic AVOID I range and range rate data with the periodic theodolite data, the theodolite data was smoothed using a five-point moving arc polynomial. Four-point Lagrangian interpolation was used to obtain theodolite range and range rate between aircraft at the same instant of time that AVOID I range and range rate measurements were made. The statistical mean error and standard deviation of the raw AVOID I data from the smoothed theodolite data was then calculated.

Table VII-I is a typical computer printout of the theodolite and AVOID I measurements of range, range rate, and Tau, together with the difference between the two. The encounter is a nominal 320 knot head-on situation. The first column on the left represents the time to the nearest millisecond at which the AVOID I made a range measurement (measured in the seventh interrogation set of the round). The second column marked Range A/C (NMI) is the AVOID I raw range measurement; the third column labelled Range Theodolite (NMI) is the smoothed theodolite range measurement; the fourth column is the difference between the AVOID I range measurement and the theodolite range measurement. The fifth column is the AVOID I range rate measurement; the sixth column is the theodolite range rate measurement; and the seventh column is the difference between the AVOID I range rate measurement and the theodolite range rate measurement. The eighth column is the AVOID I Tau (range divided by range rate) computation; the ninth column is the theodolite computation, and the tenth column is the difference between AVOID I Tau computation and the theodolite Tau computation. Tabulated at the bottom of table VII-I are the mean, rms, and sigma errors in range, range rate, and Tau. Additional computer printouts will be found in Appendices D through H.

The theodolite tracking is most accurate when the aircraft are on a flight path which is parallel to a line passing through the six theodolite sites, with three theodolites tracking each of two aircraft. Therefore, the flight encounters were confined to two aircraft encounters of the tail chase, head-on, and parallel overtake variety. In addition to the aforementioned collision courses, non-collision courses which did not require Tau alarms were flown. This established the stability of the CAS to give an alarm when required and not to give an alarm when not required.

Since the communications reliability portion of the flight test established that a satisfactory link was provided for all angles of encounter (except for a slightly marginal Tau 2 warning range between the P-3 and A-3 in the head-on case at an extrapolated speed of 1200 knots), it was not deemed necessary to repeat that aspect of the evaluation during the theodolite tests. Therefore, the three basic types of encounters flown on the theodolite range were considered to be ample to make a valid determination of range, range rate, and warning time accuracies.

The head-on profile with different pairs of aircraft was the most useful configuration, providing closing rates from 300 to 900 knots; 26 of these were flown. The tail chase provided closing rate data in the 150-knot range; 9 of these were flown. The parallel overtake profile with offsets between the two courses flown of 1 to 2 nmi provided closing rate data in the 50 to 280 knot region and provided data on how effective the CAS was in providing the Tau 2 alarm while inhibiting the Tau 1 alarm. Five of these profiles were flown.

Since the theodolite range is integral with a congested terminal area, a minimum of 1000 ft altitude separation was maintained between aircraft with operations usually below 7000 ft altitude. During some flights, in order to force the CAS to go into a Tau 1 mode (Tau 1 requires an altitude separation of 600 ft at or below 9500 ft, 800 ft above 9500 ft), the digitizing altimeter output to the CAS was disconnected and suitable fixed altitude gray code signals connected to each of the CAS equipments. This provided the altitude separation required for the generation of Tau 1 commands. In encounters at closing rates greater than 560 knots, at true altitudes of 5000 to 7000 ft, the CAS was forced into the greater than 9500 ft altitude mode by furnishing gray code signals equivalent to 10,000 ft in one aircraft and 10,800 ft in the other. In this mode the transmitted power was increased by approximately 4 db to provide the additional communications range required for high closing rates.

The theodolite range basically is limited to tracking aircraft separated by not more than 10 nmi with each of two aircraft located at the outer extremes of the range. At closing rates greater than 738 knots, theodolite tracking was not available for the initial turn on of the Tau 2 alarm, since the range at which those alarms occur is beyond the 10 nmi limitation. On some of the high speed runs where the vectoring and timing had to be precise to place the aircraft at the outer extremes of the range

A

AIRCRAFT- NC-117 PRINTOUT OF RANGE AND RANGE RATE TO P3A  
 FLIGHT NO. 8  
 ENCOUNTER NO. 16

TIME			*****RANGE*****			*****RANGE RATE**		
H	M	SEC	A/C (NMI)	THEOD (NMI)	DIFF (NMI)	A/C (KNTS)	THEOD (KNTS)	DIFF (KNTS)
14	25	14.950	9.7760	9.4793	0.2967	456.000	436.663	19.337
14	25	18.489	9.3150	9.0505	0.2645	438.000	436.904	1.096
14	25	22.053	8.8710	8.6158	0.2552	462.000	437.962	124.038
14	25	25.591	8.4100	8.1863	0.2237	430.000	436.099	6.099
14	25	22.692	7.9380	7.3308	0.2072	468.000	433.312	134.688
14	25	26.219	7.0930	6.9039	0.1891	456.000	436.246	19.754
14	25	29.785	6.4450	6.4735	0.1915	450.000	435.798	14.202
14	25	26.469	5.8100	5.6624	0.1476	450.000	437.567	12.433
14	25	29.645	5.4310	5.2764	0.1546	450.000	439.213	19.213
14	25	22.791	5.0360	4.8912	0.1448	450.000	440.609	10.609
14	25	55.957	4.6410	4.5038	0.1372	456.000	440.076	5.924
14	25	29.113	4.2860	4.1204	0.1256	456.000	436.831	19.169
14	26	2.249	3.8510	3.7377	0.1133	456.000	440.580	15.420
14	26	5.425	3.4560	3.3492	0.1068	456.000	439.037	6.963
14	26	8.569	3.0610	2.9660	0.0950	456.000	438.453	7.547
14	26	11.735	2.6660	2.5798	0.0862	456.000	438.582	7.453
14	26	14.891	2.2710	2.1966	0.0744	456.000	437.223	8.777
14	26	18.027	1.8760	1.8156	0.0604	456.000	436.007	9.993
14	26	21.203	1.4810	1.4310	0.0500	444.000	435.651	8.351
14	26	24.349	1.0860	1.0521	0.0339	444.000	432.398	11.602

TABLE VII-1. RANGE, RANGE RATE AND  
TAU DATA FOR HEAD-ON ENCOUNTER  
(437 KNOTS) ON THEODOLITE RANGE

D RANGE RATE TO P3A

*****RANGE RATE*****			*****TAU*****		
A/C (KNTS)	THEOD (KNTS)	DIFF (KNTS)	A/C (SEC)	THEOD (SEC)	DIFF (SEC)
456.000	436.663	19.337	77.18	78.15	-0.97
438.000	436.904	1.096	76.56	74.57	1.99
462.000	437.962	24.038	69.12	70.82	-1.70
450.000	436.099	13.901	67.28	67.58	-0.30
468.000	433.312	34.688	57.98	60.91	-2.92
456.000	436.246	19.754	TAU2 → 56.00	56.97	-0.98
450.000	435.798	14.202	53.32	53.48	-0.16
450.000	437.567	12.433	46.48	46.59	-0.11
450.000	439.213	10.787	43.45	43.25	0.20
450.000	440.609	9.391	40.29	39.96	0.32
456.000	440.076	15.924	36.64	36.84	-0.20
456.000	436.831	19.169	33.52	33.96	-0.44
456.000	440.580	15.420	30.40	30.54	-0.14
456.000	439.037	16.963	TAU1 → 27.28	27.46	-0.18
456.000	438.453	17.547	24.17	24.35	-0.19
456.000	438.582	17.418	21.05	21.18	-0.13
456.000	437.223	18.777	17.93	18.09	-0.16
456.000	438.007	19.993	14.81	14.99	-0.18
444.000	435.651	8.349	12.01	11.83	0.18
444.000	432.398	11.602	8.81	8.76	0.05

W/O WITH FRUIT

AIRCRAFT= NC-117 PRINTOUT OF RANGE AND RANGE RATE TO P3A  
FLIGHT NO. 8  
ENCOUNTER NO. 16

\*\*\*\*\*RANGE\*\*\*\*\*

POINTS 20  
MEAN= 0.1679 NM 898.53 FT  
RMS= 0.1628 NM 1001.42 FT  
SIGMA= 0.0747 NM 453.62 FT

\*\*\*\*\*RANGE RATE\*\*\*\*\*

POINTS 20  
MEAN= 16.0395 KTS  
RMS= 17.3420 KTS  
SIGMA= 6.7653 KTS

\*\*\*\*\*

POINTS  
MEAN=  
RMS=  
SIGMA=

TABLE VII-1. RANGE, RANGE RATE AND  
 TAU DATA FOR HEAD-ON ENCOUNTER  
 (437 KNOTS) ON THEODOLITE RANGE  
 (continued)

RANGE RATE TO P3A

\*\*RANGE RATE\*\*\*\*\*

\*\*\*\*\*TAU\*\*\*\*\*

TS 20  
 ■ 16.0395 KTS  
 ■ 17.3420 KTS  
 ■ 6.7653 KTS

POINTS 2  
 MEAN= -0.27 SECS  
 RMS= 0.05 SECS  
 SIGMA= 0.02 SECS

at the same time, the theodolite tracks did not commence until the aircraft were inside of the Tau 2 zone. On some encounters, the theodolite tracking data was erratic near the outer limits of the range and the initial Tau 2 alarm was not under usable theodolite surveillance. In two cases, the theodolite tracking was erratic due to a cloud cover for several data points before and after initiation of the Tau 1 alarm, necessitating the discarding of that data.

In a collision encounter between two aircraft in which there is altitude separation and during which one aircraft passes over a second aircraft at the point of closest approach, there is a transitional zone where as the ratio of the slant range between aircraft to the altitude separation becomes small, the closing rate decreases rapidly to zero as the aircraft pass over each other and then changes rapidly as they separate. For example, on a 900 knot head-on encounter, the closing rate decreases from 700 to 0 knots in approximately 1 second. The AVOID I is not capable of making accurate measurements under these conditions of deceleration nor is it required; true collision courses are not associated with accelerations of this magnitude. To preclude transitional zone problems, the AVOID I data was truncated in the near range based on closing rate and altitude separation.

#### RANGE AND RANGE RATE ACCURACIES

As background for understanding the range rate statistics which follow, the AVOID I techniques utilized for the measurement of range and range rate will be described.

The AVOID I determines the range to an intruder by identifying the range bin in which an intruder's reply falls. In the range 0 to 4.9 nmi., 594 bins are provided each of which is a constant 50-foot width. From 4.9 to 16.1 nmi the bin widths are incremented at range intervals which become increasingly wider as depicted in Figure VII-I. At range intervals from 4.9 to 5.3 nmi, the bin width is incremented to 54 feet; at the range interval from 14.8 to 16.1 nmi the bin width is incremented to 168 feet. There are 14 such range intervals from 4.9 to 16.1 nmi, each of which contains 48 range bins. The range bin accumulative total from 0 to 16.1 nmi is 1266 bins. The variable width bins, increasing with range, were chosen primarily to conserve memory. It will be noted that the AVOID I utilizes narrow bin widths in the critical Tau 1 range up to 4.9 nmi for high accuracy in the measurement of range and range rate. With this high range resolution, no tracking servo is required and no attempt is made to determine the relative position of the reply pulse in the bin. The AVOID I simply makes a determination of the presence or absence of a reply pulse in the bin. In accordance with recommendations of NAVAIRDEVGEN engineers, all

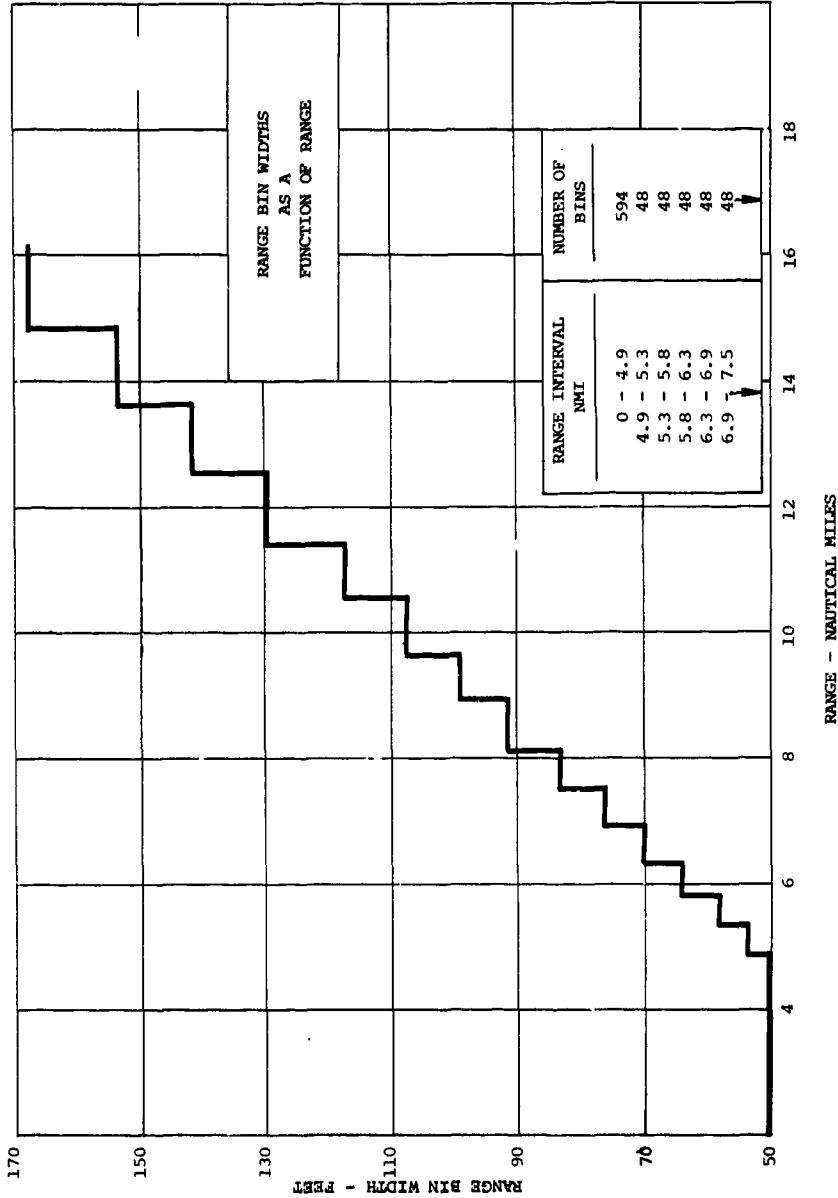

Figur. 11-1. Range Bin Widths Versus Range

future AVOID systems will utilize 50 ft bin widths throughout the 16.1 nmi range to ensure very low false alarm rates in dense traffic environments. With the advent of microprocessors, this approach has become viable from the standpoint of size and cost.

Range rate is determined by sensing the number of bins skipped over a 3-second period. Target discrimination in the presence of uncorrelated replies (fruit) and other target replies is provided by intermediate correlation every 0.5 second which demands that the bins occupied by reply pulses fit a prescribed curve (within upper and lower limits) which takes into account aircraft acceleration, bin splitting, the variable bin width and the Tau criteria.

Target correlation data is stored every 0.5 second for use during subsequent 0.5 second intervals. Failure to meet the correlation criteria in any 0.5 second interval breaks track on that target. The range bins further in range then are examined until another target is found (if one exists). Thus, only when a target is a threat is it tracked past the second set of interrogations (7 sets of interrogations being a complete sequence). Therefore, aircraft on the periphery of dense terminal area traffic which do not encounter threatening targets will operate at very low interrogation rates. This is one of the factors which keeps the number of uncorrelated replies to levels which can be handled by the processor. Essentially, the range and range rate errors in combination with the round time duration determine the accuracy with which the Tau 2 and Tau 1 alarms are displayed. The critical encounters are those which occur at low closing rates where errors in range rate can cause a much larger percentage error in the warning time than those at high closing rates. Below 40 knots, the minimum range criteria of 0.5 nmi for Tau 1 applies and serves as a back-up threshold for closing rates greater than 40 knots. This requires good range accuracy in the 0 to 0.5 nmi interval if the warnings are to be accurate. At higher closing rates, the Tau equation can tolerate errors in range which would be unacceptable in the Tau 1 minimum range zone.

The sources of error in the range and range rate measurements include:

- a. The rise time of the ranging pulse
- b. The jitter in the transmitted ranging pulse
- c. The jitter in the receiver as a function of signal to noise S/N and bandwidth
- d. Fruit
- e. The width of the range bins
- f. Ranging pulses from intruder B (co-range with intruder A) entering the range bins together with the ranging pulses of intruder A

## g. The time interval over which the range rate is measured

No attempt was made to determine the contribution of each error source to the overall error.

Table VII-2 is a tabulation of the overall range and range rate statistics with subgroupings of data without fruit and data with fruit. The total data sample consists of 1839 range and 1839 range rate measurements. Of the 1839 measurements, 421 were flown injecting a nominal 32,000 uncorrelated replies per second above threshold (fruit) and a nominal 6144 (1536 interrogation quads) probes per second above threshold (simulating those probes emanating from a large intruder population) into the front end of the AVOID I receiver approximating Honeywell's simulations of the Los Angeles Basin in 1982. The remaining 1418 measurements were made without fruit or probes injected so that a statistical determination could be made as to the effect of fruit and probes on the accuracy of measurement of range and range rate. More flights with fruit were flown, but, unfortunately, on these flights there were technical problems with the theodolite range which resulted in unusable data.

TABLE VII-2. RANGE - RANGE RATE ERROR STATISTICS

Group	Data Sample N	Range Error		Range Rate Error	
		Mean % of Range	Sigma Feet	Mean Knots	Sigma Knots
All Data	1839	+2.5	154	+10	11
Data Without Fruit	1418	+2.7	12	+ 9	10
Data With Fruit*	421	+2.1	197	+13	13

\* Predicted fruit rate in Appendix A.

The mean of the range differences between the AVOID I CAS range measurements and the theodolite range measurements was determined by a least squares fit of the data. Referring to table VII-2, the theodolite data sample of 1839 measurements, including data with and without

fruit, had a mean error of 2.5 percent of range with a standard deviation of 154 feet, and a mean range rate error of 10 knots with a standard deviation of 11 knots. Without fruit, the data consisted of 1418 measurements with a mean range error of 2.7 percent of range and a standard deviation of 132 feet and a mean range rate error of 9 knots with a standard deviation of 10 knots. With fruit, the data consisted of 421 measurements with a mean range error of 2.1 percent of range and a standard deviation of 197 feet, and a mean range rate error of 13 knots with a standard deviation of 13 knots.

As can be seen, fruit did increase the standard deviation of the error both in range and range rate and increased the mean range rate error while decreasing the mean range error percentage. Since the AVOID I will identify a threat based on the earliest range on which it can develop a track, when fruit does occupy a range bin closer in range than the real target, and is close enough to form a track with the real target and other fruit, it can result in the measurement of a lower range than without fruit. However, the overall errors with fruit at the predicted rate of Appendix A are small and, together with the system implementation of the threat equations, result in warning times which are tightly controlled with respect to the threshold.

The range slope error was the result of range bins which were more than 50 feet wide and which were not generated directly from the clock pulses. This is easily correctable. With the necessary changes, the improvement in the mean range accuracy at the maximum range of the equipment would be expected to be 10:1.

In order to determine the dependency of the range and range rate errors on range between aircraft, and whether or not the aircraft are opening or closing on each other, the data was further divided into subgroups. Each of the three main data groups -- all data, data without fruit and data with fruit were broken down into opening and closing data subgroups. The opening and closing subgroups were then broken down further into subgroups with range between aircraft as a parameter (1 nmi intervals from 0 to 10 nmi). These statistics will be found in Appendix I.

Analysis of the subgroup statistics for dependency indicates that the range and range rate errors are dependent on whether the range between aircraft is increasing or decreasing with time, are dependent on the range between aircraft and are dependent on fruit. When the range between aircraft is increasing (opening), the deviation from the mean range is only 1/4 of the deviation at 5 nmi closing, even though in both cases the bin widths are 50 feet; the range rate mean error is only 1/10 of what it is when the range is decreasing. The reasons for those effects appear to be rather complex and have not fully been explained and they are being studied.

The dependency of the range and range rate errors on range is due, in addition to signal-to-noise noise effects, to the accumulative error in the range bins due to error effects mentioned previously, and the fact that 50 ft bins are used only from -3 nmi to 5 nmi, gradually increasing to 168 feet at the maximum range of the equipment.

#### WARNING TIME ACCURACY

The Tau 2 and Tau 1 warning time accuracies using the theodolite as a reference standard were determined for the collision encounters flown on the Patuxent River Range. The majority of the encounters provided both Tau 2 and Tau 1 warnings. In some of the encounters, the theodolite tracking commenced inside of the Tau 2 zone, thus providing only a meaningful Tau 1 warning. In other encounters, the combination of the miss distance and closing rate was such that only a Tau 2 warning was given.

In order to determine how early or late the Tau 2 and Tau 1 alarms were given, the time in seconds at which the intruder was first a Tau 2 or Tau 1 threat was read from the computer printout of the AVOID I data recorded on the digital incremental tape transport installed in each aircraft. Then the actual value of Tau was established by referring to the theodolite computer printout of range, range rate and Tau at the same instant of time that the warning was recorded in flight. This value was then compared with the threshold Tau (the desired warning time in seconds) as computed from the closing rate measured by the theodolites. The difference between the actual Tau and the threshold Tau yielded the number of seconds the Tau warning in the aircraft deviated from the desired threshold. An actual Tau greater than the threshold meant that the warning was early and an actual Tau less than the threshold meant that the warning was late.

For purposes of developing additional Tau 1 warning statistics, collision encounters at altitude separations greater than co-altitude were considered to be co-altitude. Once the theodolite measured Tau was less than the Tau 1 threshold corresponding to the theodolite measured range rate, the time of the first Tau 2 display for which the AVOID I calculated a Tau less than its Tau 1 threshold was considered to be the time at which a Tau 1 command was given. Since the AVOID I processing of Tau 2 targets which have altitude separations less than 1300 feet is the same as for Tau 1 targets, statistics derived in this manner are the same as those derived from actual Tau 1 warnings.

Since the Tau thresholds vary as a function of closing rate (figure VII-2) the early and late deviations from the threshold were normalized by dividing those deviations by the Tau threshold at the particular closing rate associated with each warning and multiplying by 100. This then gives the Tau Two and Tau One warnings as a percentage deviation from their respective thresholds and permits the calculation of meaningful warning time statistics. The data was divided into two groups:

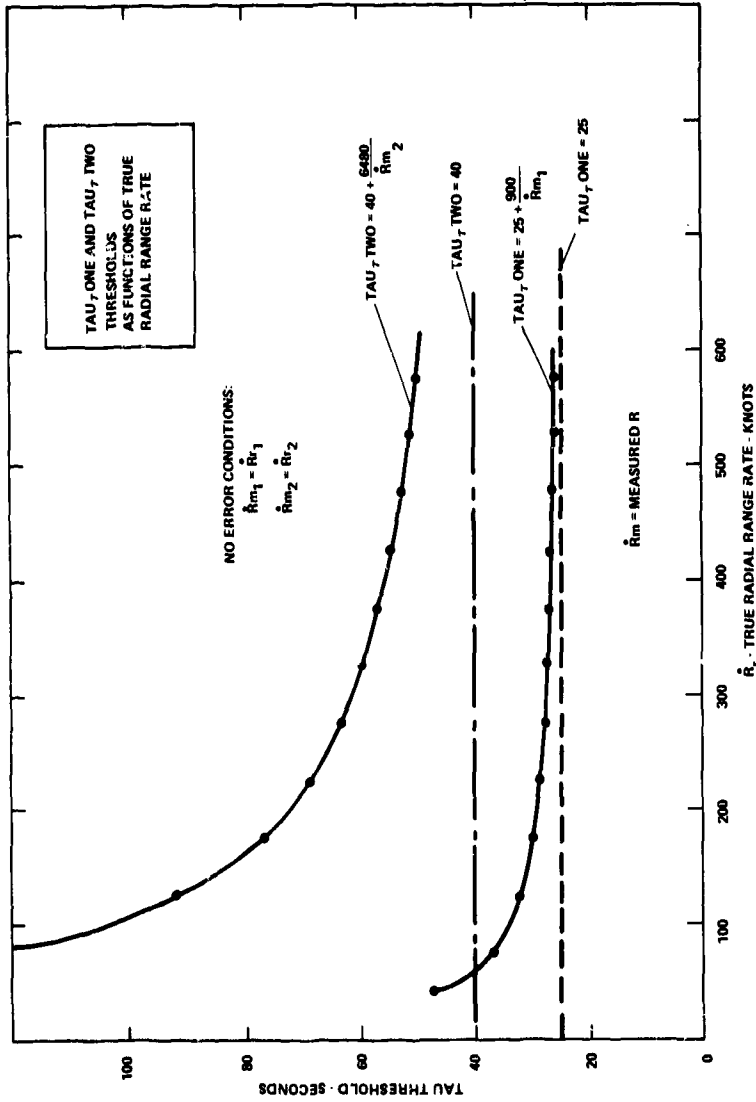

Figure VII-2. Tau One and Tau Two Thresholds

- a. Tau 1
- b. Tau 2

Histograms were plotted for each group. Since the histograms appeared to have a normal distribution, a normal distribution was hypothesized. Using maximum likelihood estimators of the mean and standard deviation, the normal curve was fitted to the experimental data on the histogram. Then the sum of the differences between the observed frequencies and the theoretical frequencies (for each group interval) squared and divided by the theoretical frequencies were compared with the value of chi-squared for a critical region of size of 0.05 and the appropriate number of degrees-of-freedom. In all cases, the chi-squared test of the data fitted to the normal distribution affirmed the validity of the hypothesis that the data was, in fact, normally distributed. The histograms and the fitted normal curves comprise Figures VII-3 and VII-4.

Referring to Figure VII-3, on the average, the Tau 2 warning time is 0.5 percent early; 68 percent of the time (the data falling within  $\pm 1$  sigma) the warning is within 3.6 percent late to 4.6 percent early, and 95 percent of the time (the data falling within  $\pm 2$  sigma) the warning is within 7.7 percent late and 8.7 percent early. The Tau 1 warning time in Figure VII-4 is seen to have an average time early of 0.4 percent; 68 percent of the time the warning is within 3.7 percent late and 4.5 percent early, and 95 percent of the time the warning is within 7.8 percent late and 8.6 percent early. During the non-collision type encounters, e.g., formation flight and encounters with large miss distances, the Tau 2 or Tau 1 warnings were not displayed when not required by ANTC-117.

The parameters which cause the warning time to deviate from the desired warning time include the range and range rate errors, round time (the time interval required to track aircraft A ability to track all other intruders and then commence another track on aircraft A), improper altitude correlation due to high fruit levels, aircraft antenna patterns, and co-range target interference all of which affect communication reliability.

On the average, the AVOID I warning times were on time (actually slightly early). This was accomplished by several techniques in the equipment implementation which advanced the Tau 2 threshold by 1 1/2 rounds (approximately 4.6 seconds) to accommodate the Tau 2, two alarms out of three criteria, and advanced the Tau 1 threshold by 1/2 a round (approximately 1.5 seconds). The Tau 1 logic is such that a Tau 2 alarm is combined with a Tau 1 alarm to satisfy the two out of three criteria so that the Tau 1 threshold needed to be advanced only by a half round. If there were no equipment range or range rate errors, and the communications reliability were perfect, the warning time distribution function would be uniform. The normal warning time distribution function is the result of the AVOID I

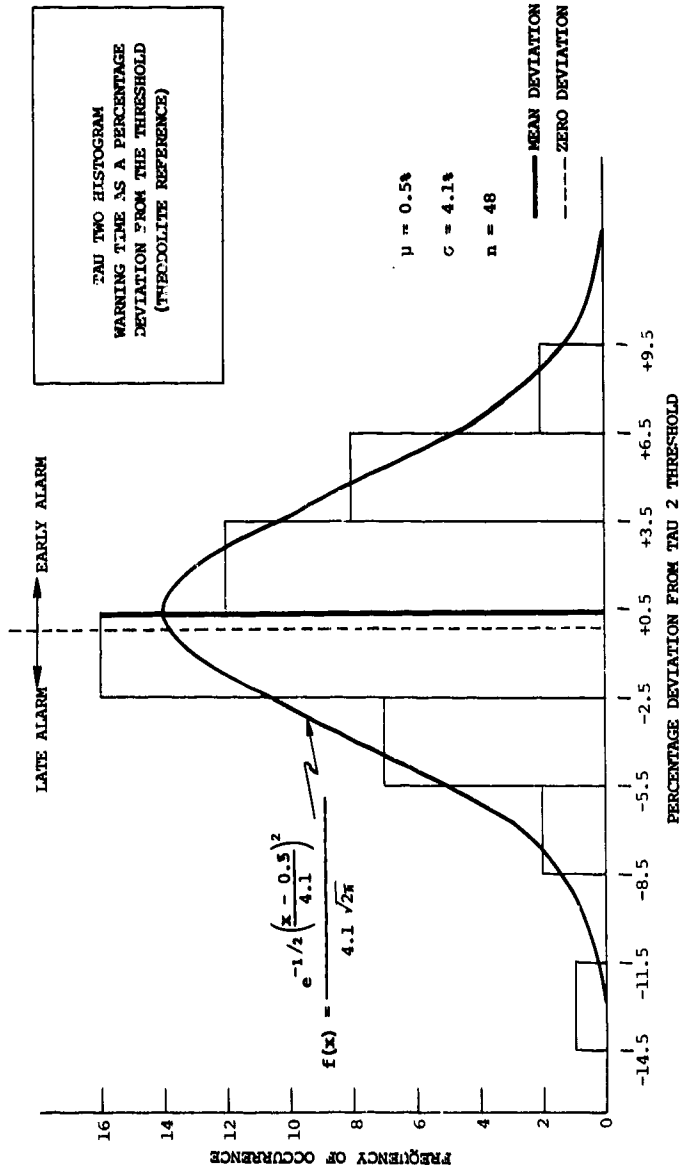

Figure VII-3. Tau Two Warning Time Histogram

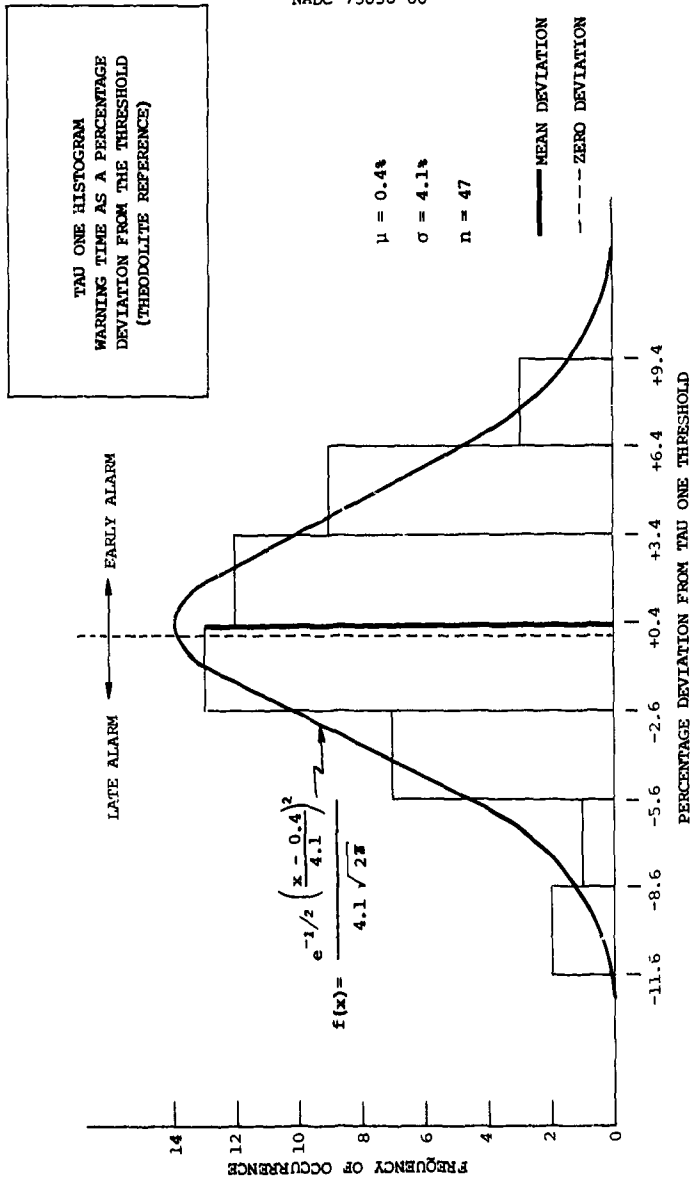

Figure VII-4. Tau One Warning Time Histogram

measurement error in the determination of range rate and to a much lesser degree, range. It is important to know in a two-aircraft encounter what the probability is that at least one aircraft will get the alarm at or in advance of the warning time threshold, enabling that aircraft to commence its part of the complementary evasive maneuver to provide safe vertical separation. This was accomplished by deriving the probability density function for the aircraft in a two-aircraft encounter which gets the alarm earliest; e.g., a sampling of two normal distributions in which only the greater of the two is retained. By dividing the probability space for the joint probability density function into three parts, the following results are obtained:

EARLY +	PROBABILITY
LATE -	
- -	$p = 1/4$
+ - } - + }	$p = 1/2$
+ +	$p = 1/4$

From the above it is seen that the probability of getting an early alarm in at least one of the aircraft is  $3/4$ . Thus, in two-aircraft encounters it would be expected that the aircraft with the earliest warning would be at or early relative to the threshold 75 percent of the time. Actually, since the individual normal warning distributions for the AVOID have a displaced mean of +0.4 percent, the early alarms actually occur 79 percent of the time. The earliest warning pdf (probability density function) as well as the cdf (cumulative distribution function) are derived in Appendix J, with the following results:

$$(\text{pdf}) f(x) = \frac{2e^{-1/2\left(\frac{x - \mu_0}{\sigma_0}\right)^2}}{\sigma_0 \sqrt{2\pi}} \cdot \frac{1}{\sigma_0 \sqrt{2\pi}} \int_{-\infty}^x e^{-1/2\left(\frac{t - \mu_0}{\sigma_0}\right)^2} dt \quad (1)$$

$$\mu = \mu_0 + \frac{\sigma_0}{\sqrt{\pi}} \quad \sigma^2 = (1 - 1/\pi) \sigma_0^2$$

$$(\text{cdf}) F(x) = \left[ \frac{1}{\sigma_0 \sqrt{2\pi}} \int_{-\infty}^x e^{-1/2\left(\frac{t - \mu_0}{\sigma_0}\right)^2} dt \right]^2 \quad (2)$$

where  $\mu_0$  = mean of the individual normal warning time distributions of each alarm of an alarm pair.

$\sigma_0$  = standard deviation of the individual normal warning time distribution of each alarm of an alarm pair.

A plot of equation (1), the pdf, will be found in Figure VII-5, using the mean and standard deviations for the normal warning time distributions established on the theodolite range. The distribution is a slightly skewed normal distribution, in which the portion of the curve to the left decreases at a faster rate and approaches zero at a smaller error deviation from the peak of the curve than the corresponding portion of the curve to the right of the peak. However, the displacement of the mean from +0.4 percent for the individual normal distribution to +2.6 percent for the earliest warning distribution is the major factor which provides most warnings at or greater than the warning time threshold. In the plot of equation (2), the cdf (Figure VII-6), it can be seen that 99 percent of the alarms in the aircraft getting the alarm first, lie in the range from -7 percent to +12 percent deviation from the warning time threshold, with 79 percent of the warnings at or greater than the threshold.

In addition to the warning time deviation from the Tau thresholds, the AVOID error in making the Tau measurements (in seconds) was determined. This was accomplished by taking the difference between the AVOID I measurement of Tau and the theodolite measurement of Tau at the

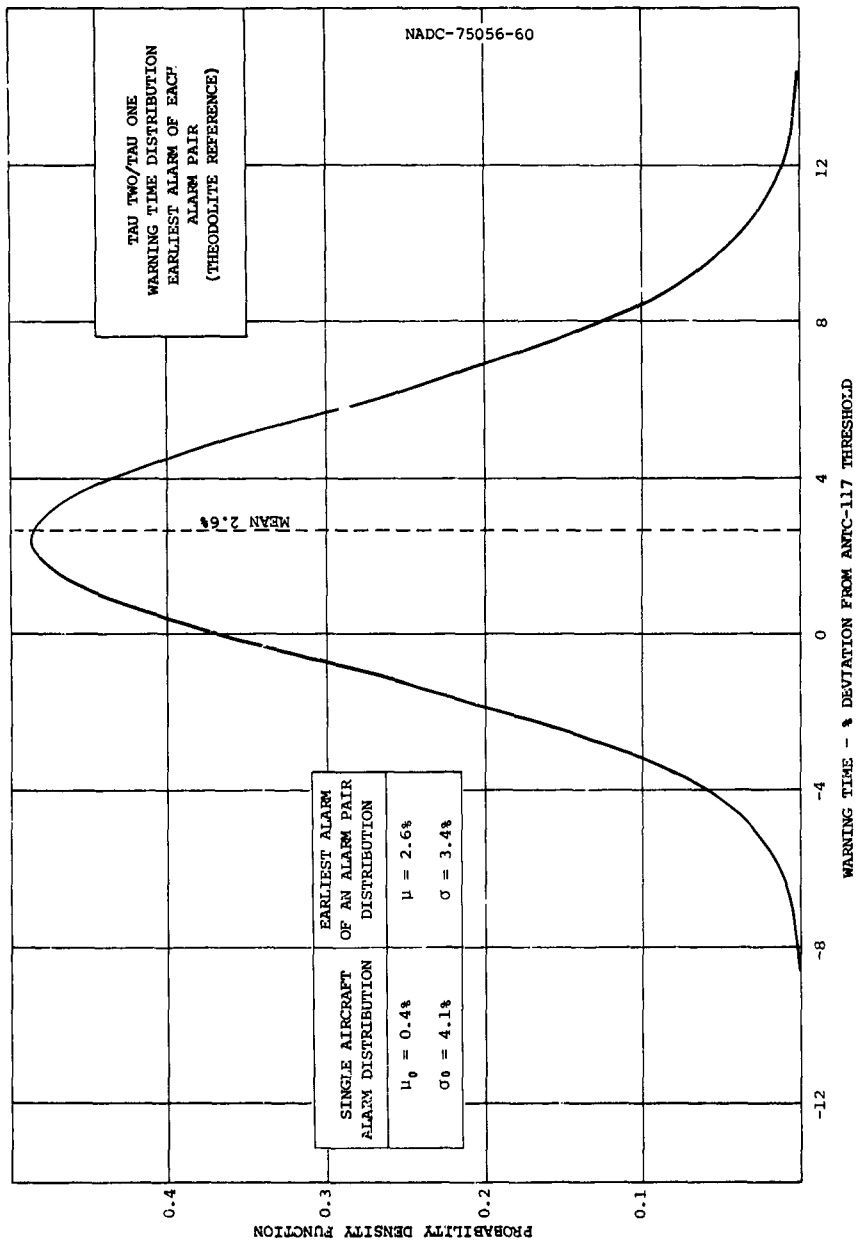

Figure VII-5. Warning Time Distribution - Earliest of an Alarm Pair.

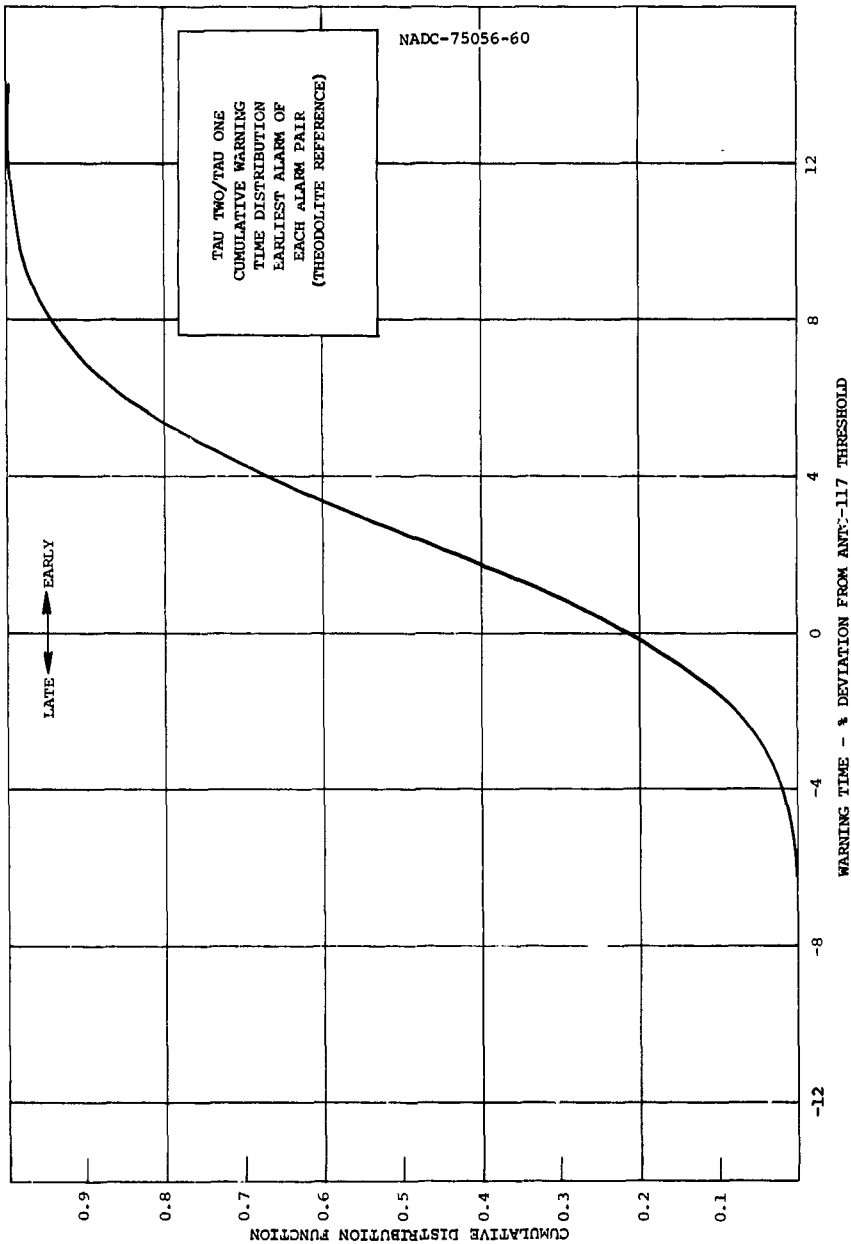

Figure VII-6. Cumulative Warning Time Distribution For Earliest Alarm of an Alarm Pair

time the alarms were given. Figure VII-7 is a histogram of the AVOID error in the measurement of Tau 2 at the time that the alarms were displayed. Note that >90% of the alarms are within an error band of  $\pm 3.4$  seconds. A similar histogram is depicted in Figure VII-8 for Tau 1. In this case 90% of the alarms are within an error band of  $\pm 1.6$  seconds.

The warning time histories of a large number of in-flight alarms which were generated while flying collision encounters via radials on the VORTAC range at Dover, Delaware were compiled. The co-range, threat situation occurred in several of the three aircraft encounters such that the altitudes of two intruders were within two overlapping altitude threat bands. It should be noted that this was a test condition with a low probability of occurrence. The probability of two aircraft at the same range being in overlapping altitude threat bands with respect to a third aircraft and converging on each other is low and the probability that the same two aircraft will remain co-range (within 100 to 200 feet) with the third aircraft is low. The joint probability of the two events is even lower. Thus the AVOID is adequately protected from deleterious co-range effects. The co-range phenomena is discussed in more detail in Chapter VIII.

The flight profiles associated with the warning time histories gathered at the VORTAC site comprise Figure VII-9. The total number of encounters flown is plotted as a function of the angle between the radials flown. The totals are then further broken down into those that were non co-altitude (NCA), co-altitude (CA), and those in which the miss distance was greater than the Tau 1 threshold (MD) and therefore resulted in no Tau 1 warning since none was required.

For efficient flight testing, the 3 aircraft encounters which would otherwise have been difficult to synchronize were standardized to start with a  $180^\circ$ ,  $90^\circ$  configuration in which 2 aircraft persisted in  $90^\circ$  encounters with each other while varying their encounter angles with respect to the third aircraft. This together with the fact that head-on encounters were the only practical way to achieve the higher closing rates accounted for the fact that the  $90^\circ$  and  $180^\circ$  course angles predominated.

In the plot of Figure VII-10, the warning time and range rate were taken directly from the computer printout of the decoded in-flight tape recording of the CAS derived parameters via the digital interface. For those encounters below 100 knots, the range rate was calculated from successive range measurements over a 6-second interval; the warning time was then calculated using the range at the time the alarm was given divided by the range rate calculated above. The range rates calculated in this manner compared favorably with the theodolite range.

TAU TWO HISTOGRAM DIFFERENCE  
 BETWEEN CAS MEASUREMENT AND  
 THEODOLITE MEASUREMENT OF  
 TAU TWO IN SECONDS FOR CLOSING RATES  
 >100 KNOTS

$\mu = -0.2$  SECOND  
 90% OF DATA WITHIN  $\pm 3.4$  SECONDS

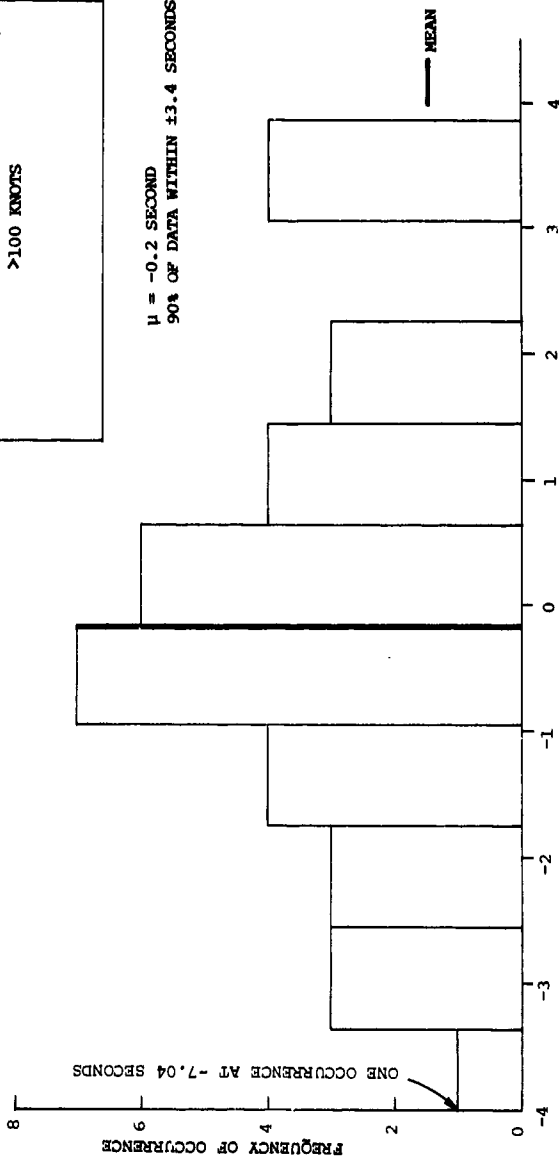

FIGURE VII-7. AVOID TAU 2 MEASUREMENT ERROR HISTOGRAM.

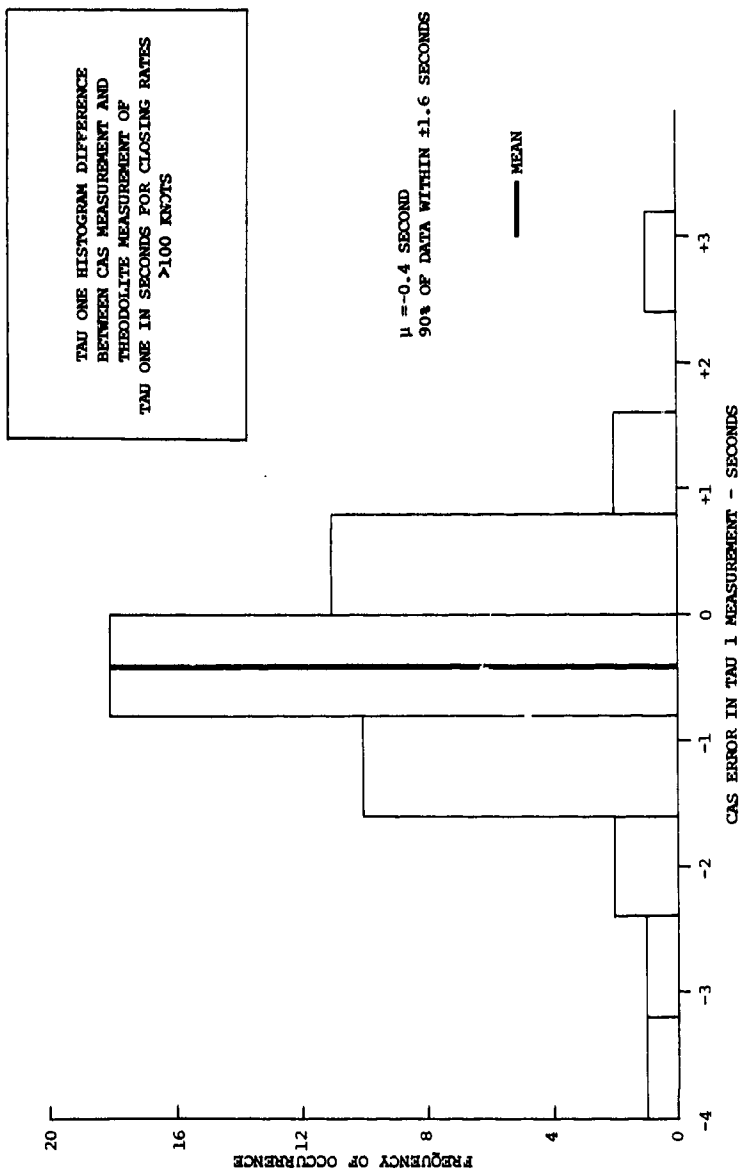

Figure VII-8. AVOID Tau 1 Measurement Error Histogram.

Referring back to Figure VII-7, it can be stated with 90% confidence that the plotted values of Tau 2 in Figure VII-10 are accurate to within  $\pm 3.4$  seconds at closing rates greater than 100 knots. The dashed lines in Figure VII-10 represent a  $\pm 8.2\%$  deviation from threshold; these boundaries encompass 94.1% of the warnings. With 90% confidence, it can be stated that for closing rates greater than 100 knots, 94.1% of the Tau 2 alarms occurred within 3.4 seconds of an upper and lower boundary of  $\pm 8.2\%$  of the Tau 2 threshold. It will be noted that there are more late alarms falling below the  $-8.2\%$  boundary than there are early alarms above the  $+8.2\%$  boundary, and that several of them are below the  $-3$  sigma boundary with a frequency slightly higher than it should be for a normal distribution (the negative tail would decrease at a somewhat slower rate than a true normal distribution, but the distribution from  $-2$  sigma to  $+3$  sigma would be for all practical purposes normal). This effect is caused by 2 or more lost communication rounds at the time the alarm should be given. This type of late alarm accounts for 3% of the data and involved the P-3 aircraft in encounters in which the antenna coverage of the right-hand side (generally the forward quadrant) of the aircraft was being utilized. Thus there are indications that the antenna location was not optimized. Collision encounters involving the NC-117/RA-3B combination did not exhibit this phenomena. However, it is important to note that during most of the flights, there was 6 db of additional attenuation in the RF links for the communications reliability tests. Seven of the nine late alarms occurred with 6 db of attenuation in the link. Without the 6 db attenuation in the link, it is probable that this group of alarms would have occurred earlier.

Figure VII-11 is a plot of the Tau 2 warning time of the aircraft which gets the alarm first in an encounter with another aircraft. (In some encounters, there were instrumentation problems in one aircraft such that no data was retrieved. Since this type of plot requires data pairs, the overall paired data sample was reduced) Thus, it can be seen quickly how often both aircraft have warning times significantly below the desired threshold. The 9 late alarms in Figure VII-10 are included in the alarm pair data. From the plot it is seen that in every case except one at 43 seconds (56 second threshold), one aircraft of the pair got the alarm essentially on time and was able to commence its portion of the required complementary maneuver on time.

Figure VII-12 is the warning time history of 312 in-flight Tau 1 alarms. Again the dashed lines represent the 2 sigma boundaries on Tau 1 warning time as established on the theodolite range. These boundaries encompass 94.2% of the Tau 1 warnings. Referring to Figure VII-8, it is found that 90% of the time the CAS measurements of Tau 1 were within  $\pm 1.6$  seconds of the theodolite measurement of Tau 1. Therefore, it can be stated with 90% confidence that for closing rates greater than 100 knots, 94.2% of the alarms were within 1.6 seconds of an upper and lower boundary of  $\pm 8.2\%$  of the Tau 1 threshold. With 90% confidence, it can

A

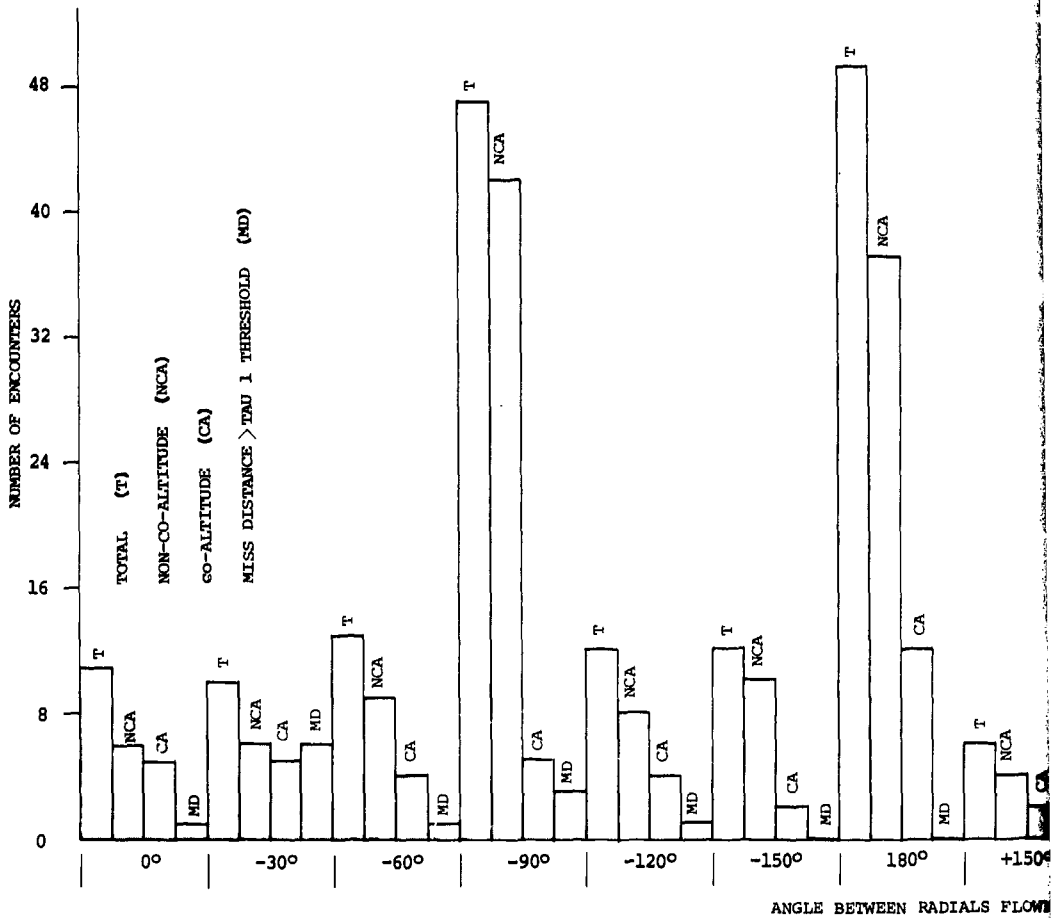

ANGLE BETWEEN RADIALS FLOW

W

FLIGHT PROFILES ASSOCIATED WITH THE  
 TAU 2 AND TAU 1 WARNING TIME HISTORIES  
 OF FIGURES VII-10 TO -13

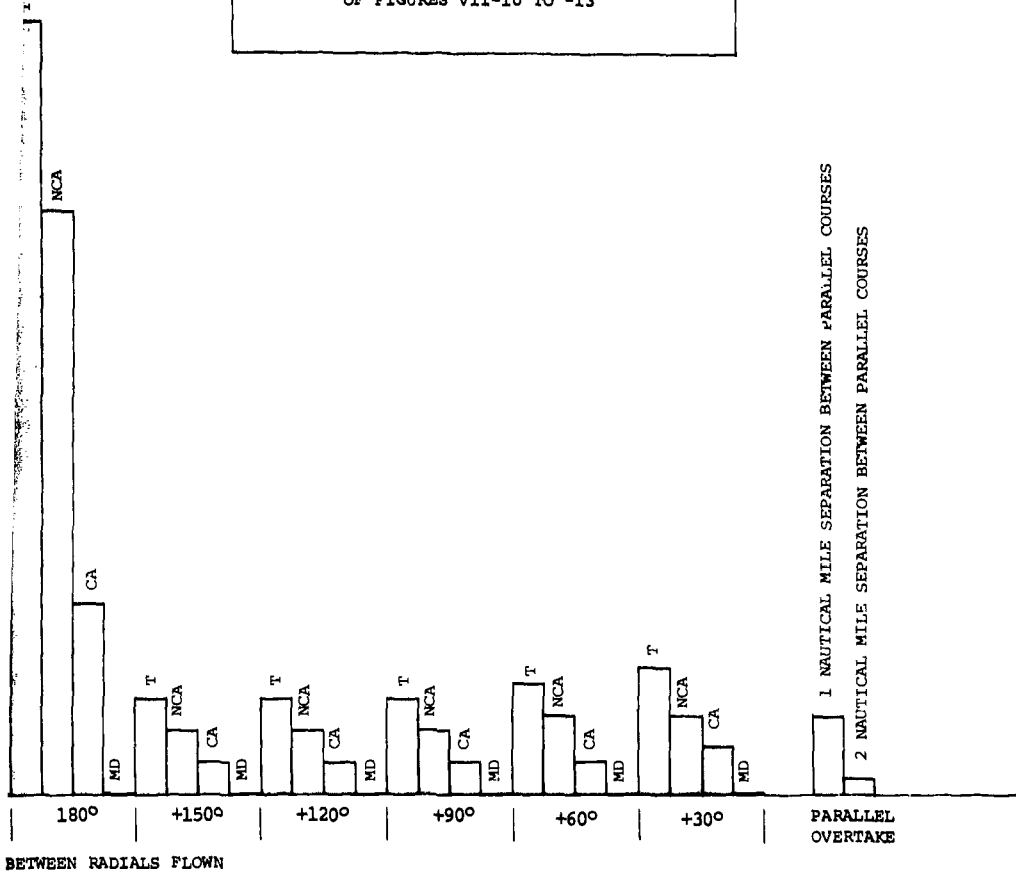
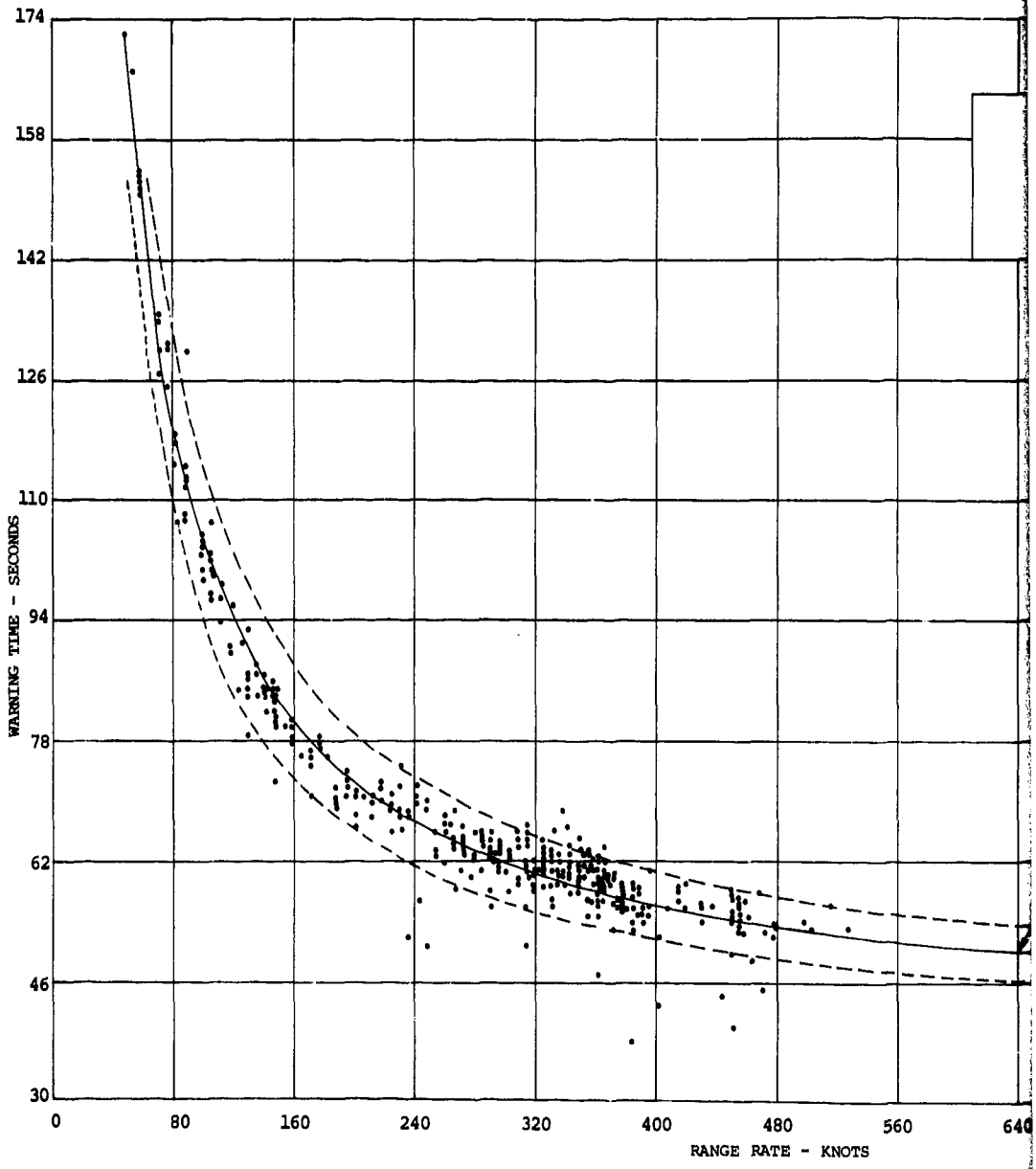

Figure VII-9. Flight Profiles For Warning Time History Plots

A



5

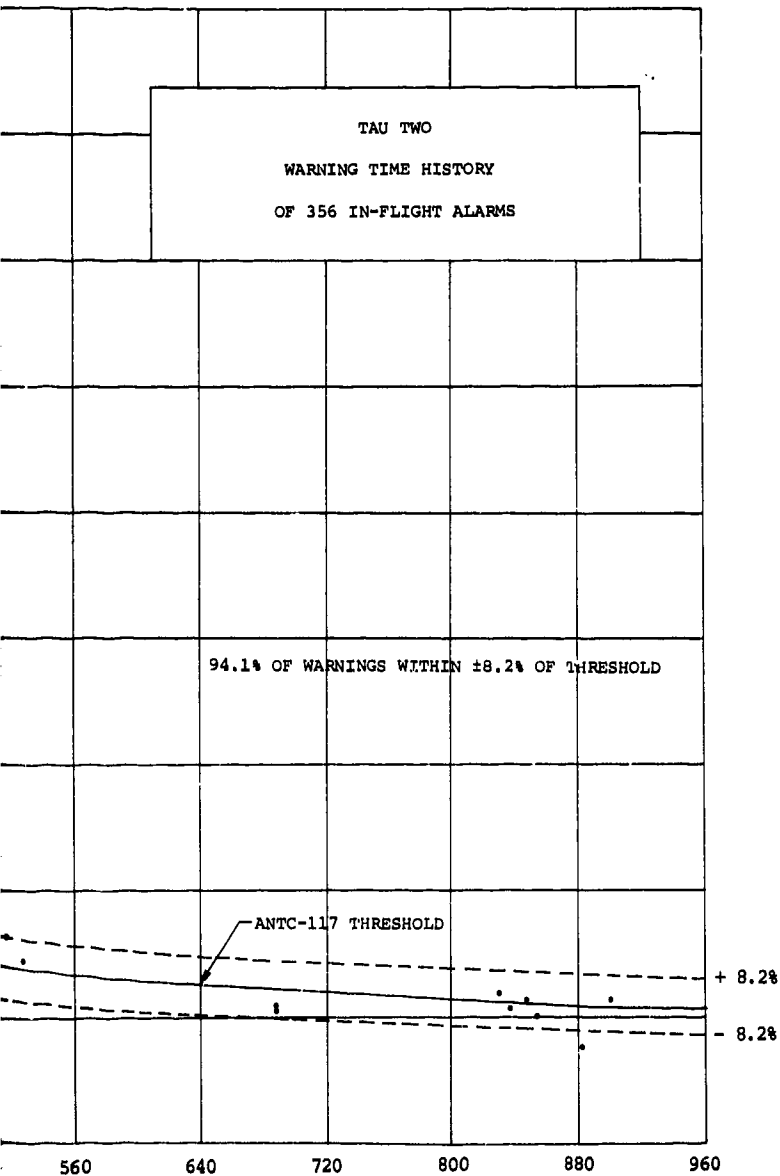
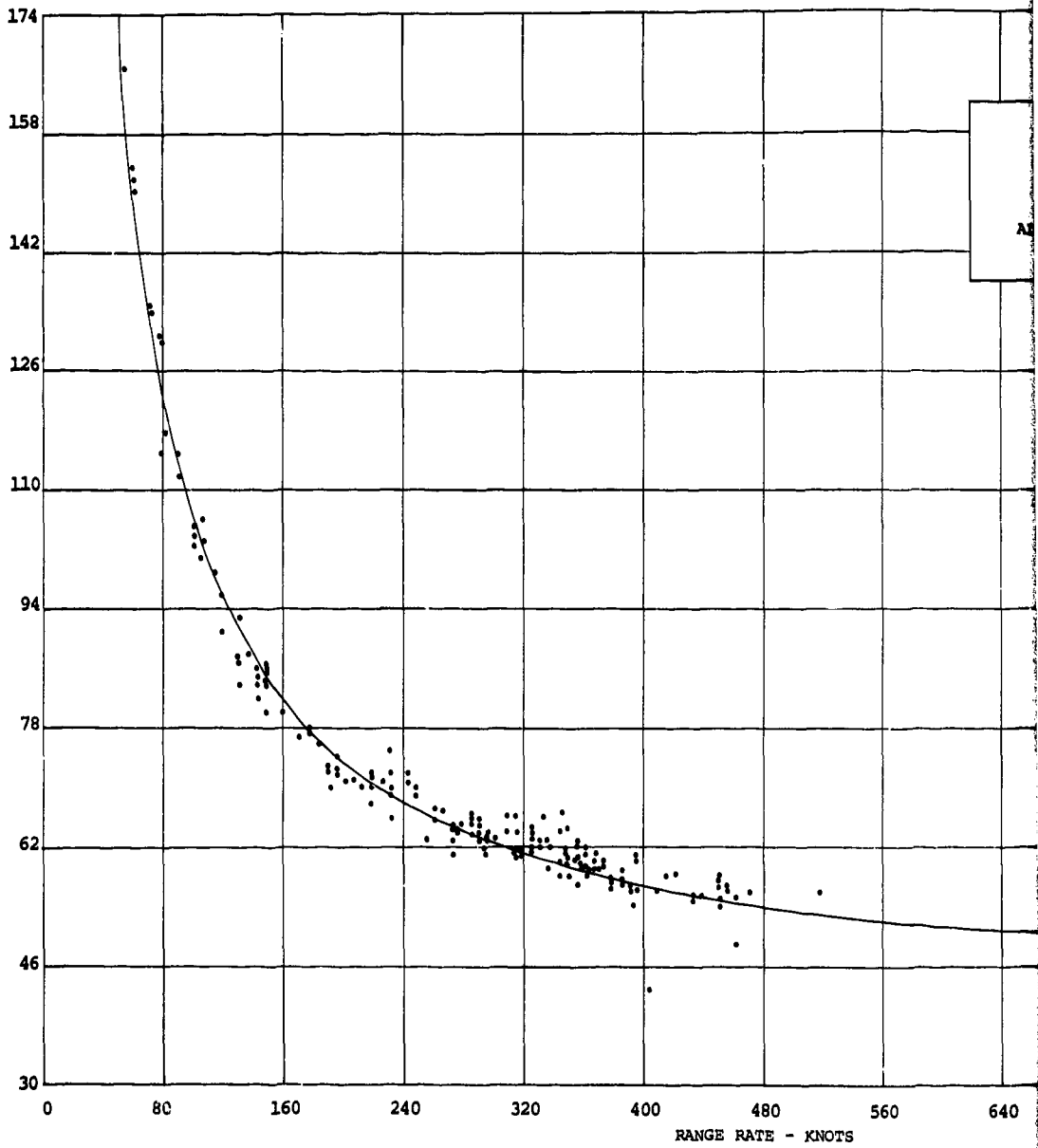

Figure VII-10. Warning Time History of 356 Tau Two Alarms.

A



B

TAU TWO  
 WARNING TIME HISTORY OF THE EARLIEST  
 ALARM IN EACH OF 167 IN-FLIGHT ALARM PAIRS

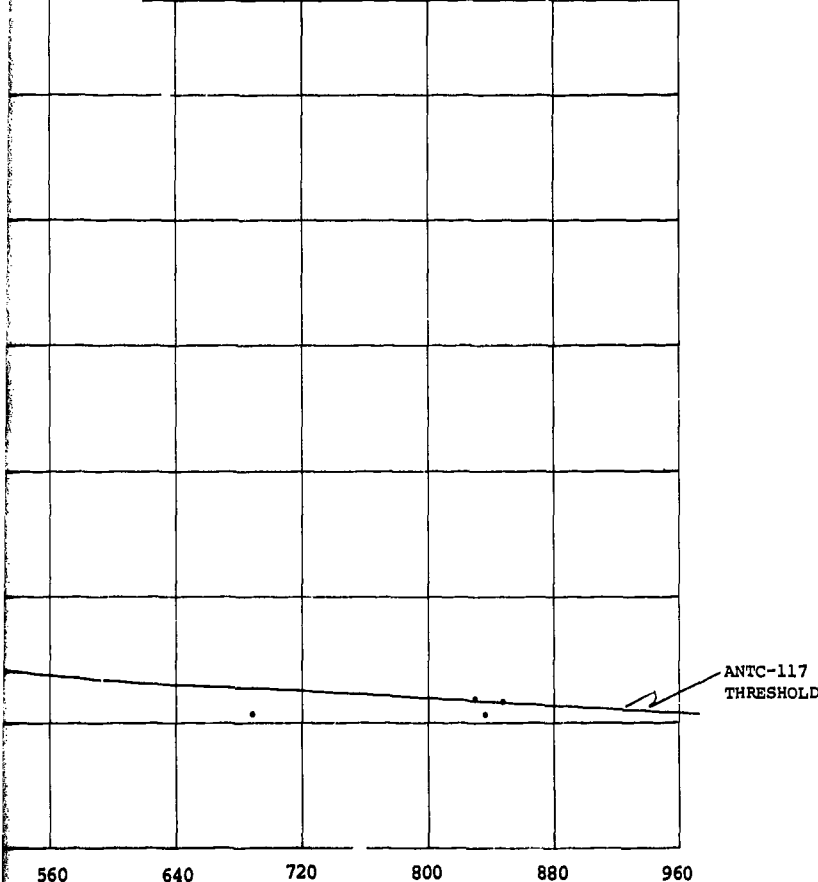
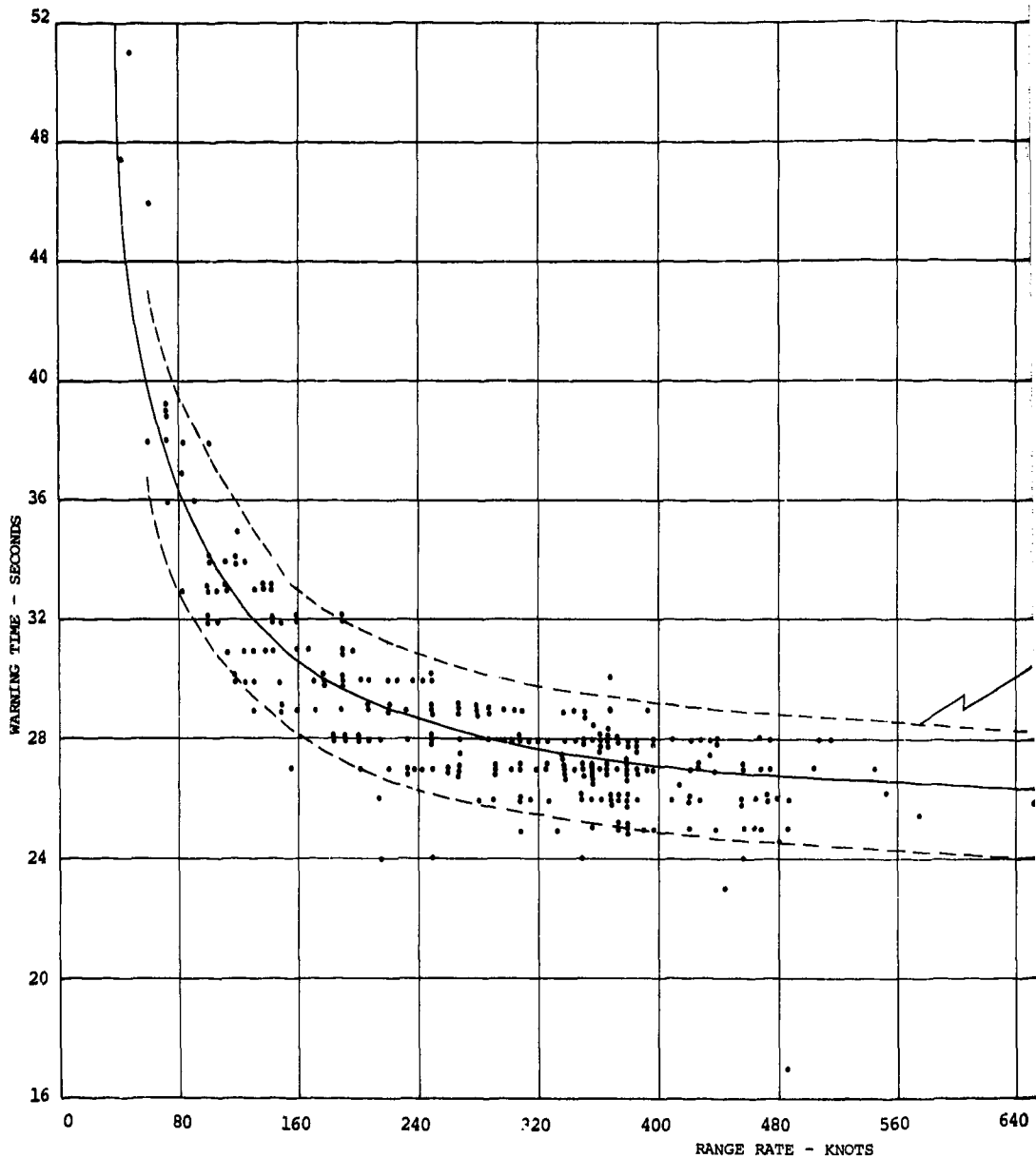

Figure VII-11. Warning Time History of the Earliest Tau 2 Alarm of an Alarm Pair.

A



B

NADC-75056-60

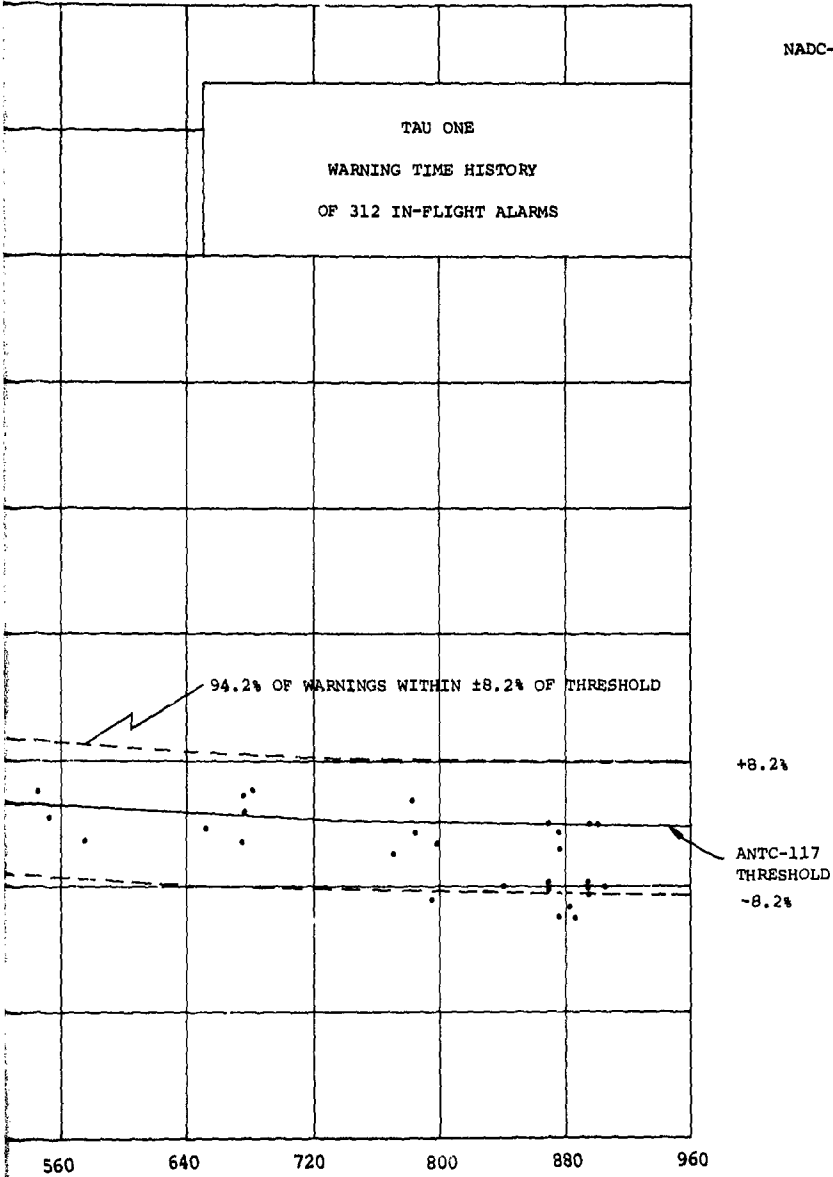

DTS

Figure VII-12. Warning Time History of 312 Tau One Alarms.

A

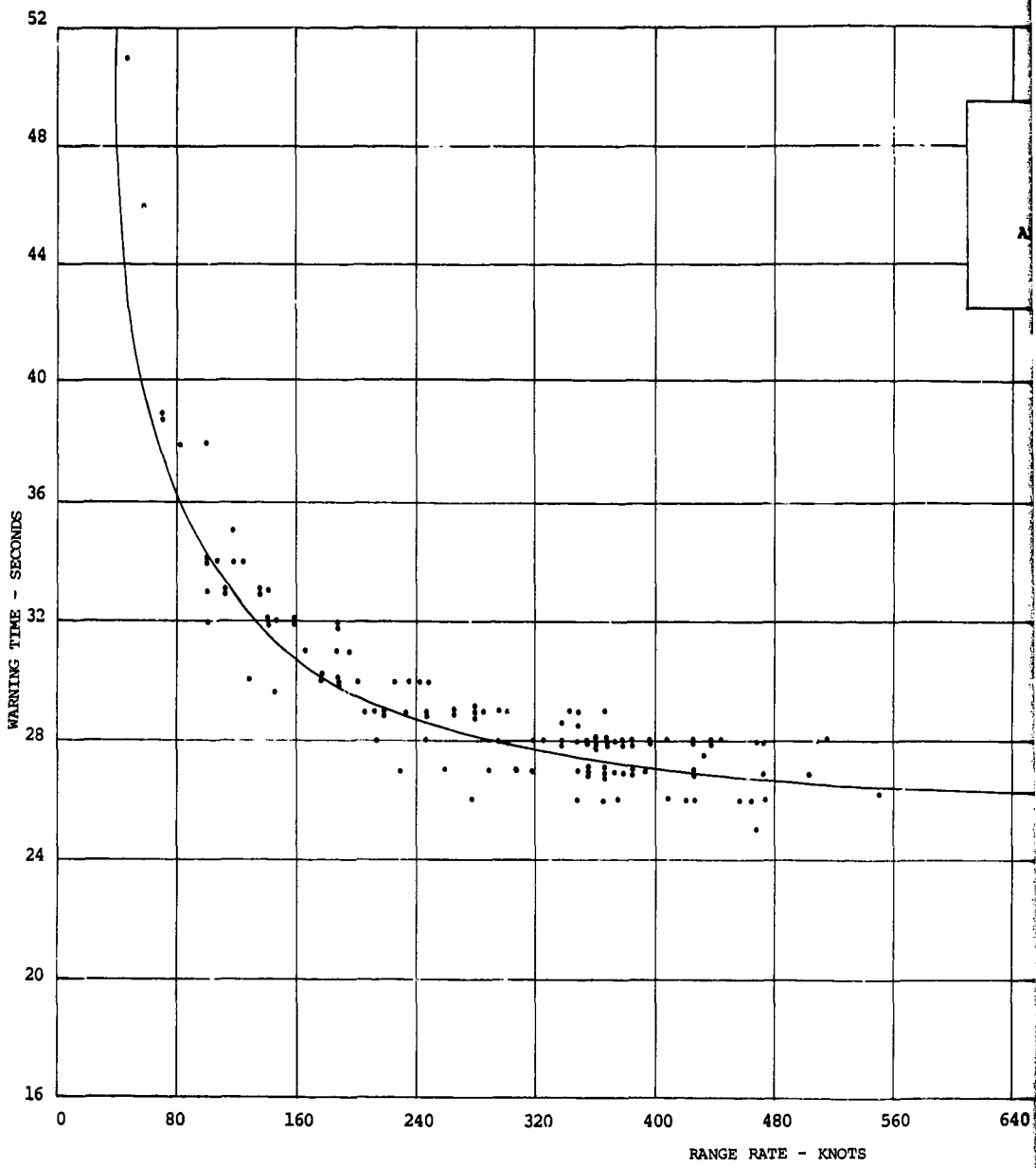

B

NADC-75056-60

TAU ONE  
WARNING TIME HISTORY OF THE EARLIEST  
ALARM IN EACH OF 139 IN-FLIGHT ALARM PAIRS

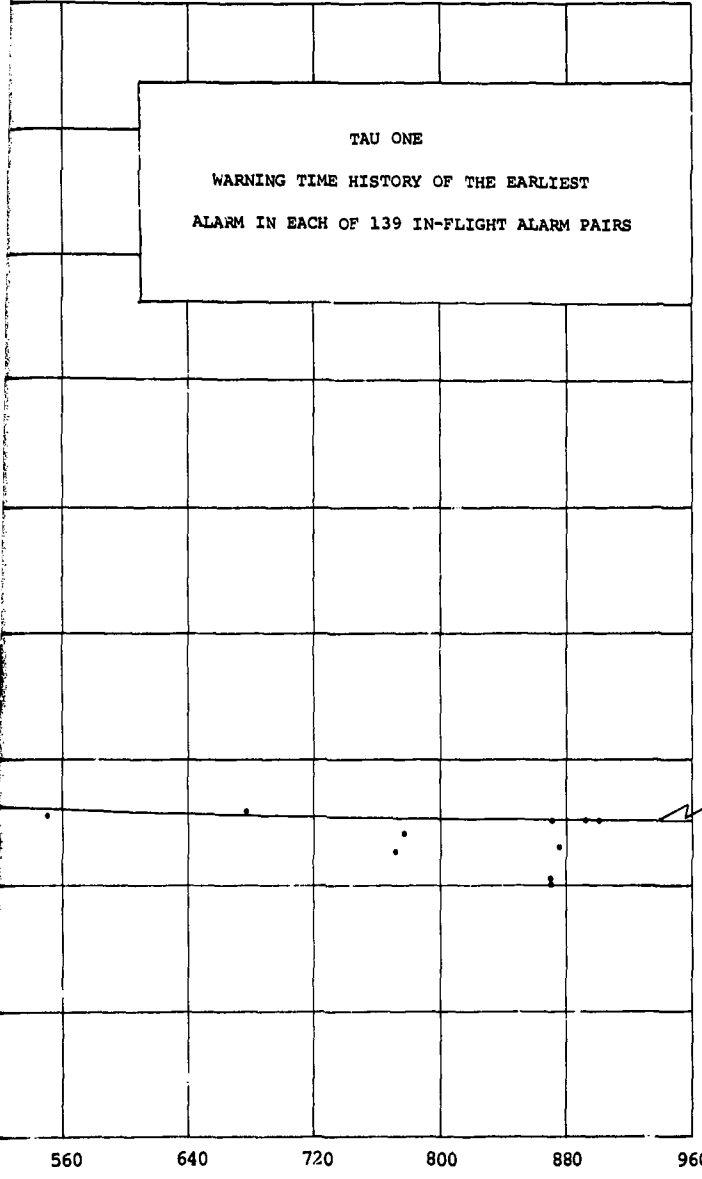

ANTC-117  
THRESHOLD

NOTS

Figure VII-13. Warning Time History of the Earliest Tau 1 Alarm of Each Alarm.

be stated that all the alarms except one were greater than 22.3 seconds. The one exception was an alarm at 17 seconds in which there was 9 db of additional attenuation in one link and 6 db in the other during a three aircraft encounter. It is probable that this alarm would have been earlier with the attenuation out of the links. At closing rates greater than 800 knots, the CAS threshold does not appear to be advanced to the degree that it is advanced at lower closing rates. This effect shows up in Figure VII-12 as alarms which tend to be somewhat late on the average.

Figure VII-13 is a plot of the earliest Tau 1 alarm for each of 139 in-flight alarm pairs. The alarms are all greater than 23.4 seconds at a confidence level of 90%. It will be noted that none of the alarms with substantial deviations from the threshold in Figure VII-12 remain; thus, in not a single case did both aircraft in a collision encounter get Tau 1 alarms which were delayed significantly. Actually in the case of the 17-second alarm, that alarm was displayed during a 3-aircraft collision encounter in which the RA-3B was on the top of the stack at 11,500 feet altitude; the P-3 was in the middle at 11,000 feet altitude; and the NC-117 was on the bottom at 10,500 feet altitude. The P-3 first saw the NC-117 below at a Tau 2 with the NC-117 of 63 seconds and displayed a limit rate descent to 200 fpm. At a Tau 2 of 45 seconds with the RA-3B, the P-3 saw the RA-3B and displayed a limit rate of ascent and descent to 200 fpm. This display continued until the P-3 lost communication with the A-3 at which time the Tau with the RA-3B should have been 23 seconds. The P-3 display changed to limit rate of descent to 200 fpm instead of dive limit rate of descent to 200 fpm. This display which did not reflect the threat with the A-3, persisted for 2 rounds (6.4 seconds) followed by a proper level off display when the Tau 1's with the A-3 and the NC-117 became 17 seconds and 29 seconds, respectively. The proper command persisted for the remainder of the encounter. The NC-117 and the RA-3B both displayed the proper commands throughout the encounter. Computer print-outs of other three aircraft encounters will be found in Appendices K through M.

Inasmuch as reliable warning time is intimately associated with a high degree of communications reliability, degradation of the power budget which goes undetected is an area of concern. To insure that the power budget is maintained at all times, the AVOID should have an automatic closed loop self-test feature. The transmitted power should be sampled by means of a probe at the antenna and fed back through an attenuator and delay line to provide a calibrated minimum input signal at the AVOID receiver. The signal should then be processed through the AVOID to establish proper operation of the correlator, Tau filter, and threat logic. Low transmitter power, low receiver sensitivity or improper processing then would be detected quickly, automatically disabling the AVOID and enabling a flashing warning light or an audible warning. Properly designed, this scheme should guarantee a power budget at all times with  $\pm 2$  db.

## CHAPTER VIII

## FALSE ALARMS

## INTRODUCTION

This chapter discusses the false alarm characteristics of the AVOID I equipment as delivered in January 1974. The false alarm rate was found to be excessive. NAVAIRDEVCON initiated many technical interchanges with Honeywell regarding false alarms, culminating in design changes and the issuance of the NAVAIRDEVCON AVOID II Requirements Document (Appendix B). This resulted in an Avoid II design which should have a false alarm rate in 1982 traffic densities which are in the 1 in 1000 hour range. It is anticipated that a similar AVOID I design augmented by additional recommended techniques also should result in false alarm rates in 1982 traffic densities which are in the 1 in 1000 hour range instead of the approximate 20 per hour exhibited in the design reported herein. In making an assessment of the impact which false alarms have on a collision avoidance system operating within an ATC (Air Traffic Control) environment, it is important to calculate the aggregate number of false alarms per hour which would occur in the most dense terminal area envisioned in the 1980 - 1990 time frame. NAVAIRDEVCON considers a false alarm rate in each aircraft in the range of 1 in 1000 hours to be satisfactory in such an environment.

Considerable effort was spent in analyzing the AVOID I system design to identify the mechanisms by which false alarms could occur, devising pertinent tests and developing analytical methods to establish false alarm rates. Even if a particular type of false alarm was believed to be of very low probability, it was identified and appropriate tests run to prove or disprove the predicted outcome.

In order to analyze systematically the false alarm phenomena it was reasoned that false alarms had to be subdivided into the following six categories:

1. Phantom Intruder Alarms due to fruit.
2. Conditional Alarm Alterations due to fruit (the alteration of a valid alarm to an alarm of another kind).
3. Conditional Alarm Alterations due to altitude scaling factors.
4. Conditional Alarm Alteration due to two aircraft which occupy overlapping altitude bands and which are co-range with a third aircraft.

5. Conditional Phantom Intruder Alarms due to multipath of the second pulse pair of the altitude encoded interrogation quad.

6. Conditional Alarm Alteration due to multipath of the second pulse pair of the altitude encoded interrogation quad.

The phenomena encountered in categories 5 and 6 did not occur after equipment modifications incorporated midway in the flight test program. A discussion of these categories will be found in chapter V. In this chapter, the remaining four categories are discussed at length. Laboratory test results together with supporting analysis of the mechanisms involved in each category are provided. One section of the chapter consists of a narrative of the false alarms which occurred during the flight tests. The last section provides conclusions.

#### GENERAL BACKGROUND

In order to understand the rationale for the experimental methods used to establish the AVOID I false alarm rate, it is necessary to understand the various operational modes of the equipment. The AVOID I basically has three automatic operational modes: one mode when in level flight (includes vertical rates up to 500 fpm), a second mode when ascending or descending at rates between 500 and 1000 fpm and a third mode when ascending or descending at greater than 1000 fpm. When operating in mode one (level flight), the AVOID I is only concerned with an altitude band within  $\pm 1300$  feet of own aircraft. Hence only the  $I_{46}$  basic altitude bands are enabled for all seven sets of interrogations comprising one sequence or round. Branch interrogations in the  $I_{13}$  and  $I_{14}$  bands in the fifth and seventh sets of interrogations further isolate a threat as to whether it is co-altitude (altitude differential of 600 feet or less) or a P-5 type threat (altitude differential of between 600 and 1300 feet) and whether it is between an altitude differential of 0 to 400 feet which requires biasing of responses to insure complementary maneuvers. The co-altitude boundaries are incremented by 200 feet in the high altitude region.

When operating in mode two, the AVOID I (if climbing) is only concerned with an altitude band of 2000 feet above to 1300 feet below or if diving just the reverse. Thus an additional altitude band, the  $I_{13}$  is enabled for all seven sets of interrogations (provided a threat exists) with branch interrogations in the  $I_{16}$  and PCA (predicted coaltitude) bands to isolate the threat as being in the 1300 to 2000 foot altitude band, the 600 to 1300 foot altitude band or the PCA band with an upper boundary equal to the sum of 600 feet and one half the altitude rate in feet per minute. Similarly, when operating in mode three, another altitude band is enabled, the  $I_{25}$  extending (if climbing) to 3200 feet above and 1300 feet below with branch interrogations in the  $I_{13}$  to isolate the threat to the 1300 to 2000 foot

altitude band or the 2000 to 3200 foot altitude band.

In mode one, the display is only enabled if essentially the same threat level is present for two out of three rounds, thus providing substantial display suppression of fruit tracks or correlations in the branch altitude bands which nearly always are separated by more than one round. In modes two and three, the display is enabled the first round in which a threat is present, and as would be expected, the fruit susceptibility is increased.

The basic fruit rates used in the false alarm tests are in accordance with the Honeywell simulations of the FAA 1982 Los Angeles Traffic Model (appendix A) during the peak hour of the peak day. In the simulation, the most dense portion of the model was selected and all aircraft were equipped with a CAS. All IFR aircraft (15% of the aircraft) were equipped with AVOID I and all VFR aircraft (85% of the aircraft) were equipped with AVOID II. As a result of the simulations, it was determined that the AVOID I would receive 32,000 fruit pulses per second and 1261 interrogations. This will be referred to as the predicted fruit rate. The simulation was then repeated with the power budget increased by 2 dB. Under these conditions, the resultant fruit was 62,000 pulses per second with 1808 interrogations. These figures slightly modified (64,000 pulses per second with 1536 interrogations) were recommended by Honeywell for purposes of the flight tests and will be referred to as the recommended fruit rate. In some of the NAVAIRDEVCON false alarm tests conducted in the laboratory, the fruit rates were raised beyond the recommended rate (as high as 96,000 pulses per second with 1536 interrogations). This was done to accelerate the rate at which false alarms were generated in order to get measurable number of false alarms during tests of reasonable duration.

#### PHANTOM INTRUDER ALARMS DUE TO FRUIT

The test series designed by NAVAIRDEVCON to generate the data for the mode 1 fruit induced phantom intruder alarms, curve 1 of figure VIII-1, consisted of operating the AVOID I in mode one in the above 9500 foot altitude band at varying fruit rates. Two hour tests were conducted at each of four different fruit rates 16K/1536, 32K/1536, 64K/1536 and 96K/1536 injected into the receiver. It is to be noted that no legitimate threats were injected during the tests at the 3 lower fruit rates. The phantom targets due to the formation of fruit TAU tracks did not appear in a two hour period until a fruit rate of 64K/1536 was reached. At that rate, two co-altitude TAU 2 phantom targets at different ranges and range rates appeared consecutively as targets above the interrogating aircraft with a limit climb rate to 200 fpm displayed twice. At the 96K/1536 fruit rate, phantom intruders appeared many times during the two hour test period. Seven of these were co-altitude TAU 2 threats above own aircraft and seven were co-altitude TAU 2 threats below own aircraft. They are classified in table VIII-1 by threat type, whether they were displayed once, twice in a row, or three times in a row

CONDITIONAL AND PHANTOM FALSE  
ALARM RATES AS A FUNCTION OF  
FRUIT RATE FOR FOLLOWING  
VERTICAL SPEEDS:

MODE 1 - LEVEL FLIGHT UP  
TO 500 FPM

MODE 2 - >500 FPM  
<1000 FPM

\* FOR TOTAL NO. OF PULSES AT  
RECEIVER, INTERROGATIONS  
RECEIVED MUST BE ADDED  
(1536 X 4) ≈ 6 KILOPULSES/SEC.

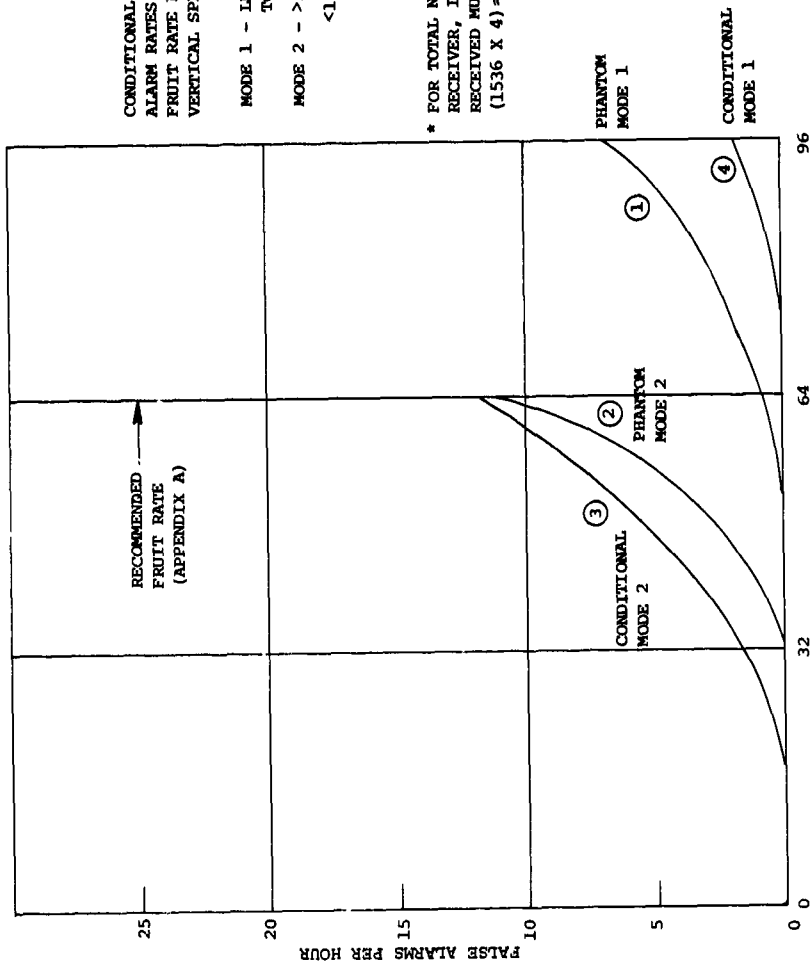

FRUIT REPIES - KILOPULSES PER SECOND\*  
Figure VIII-1. Conditional and Phantom False Alarm Rates Versus Fruit Rate.

TABLE VIII-1. PHANTOM FALSE ALARMS  
IN LEVEL FLIGHT WITH NO INTRUDERS  
(CURVE 1 FIGURE VIII-1)

Fruit KPPS	No. of Occur- rences	Round	Pilot Display	Internal Threat Status		False Alarm Mechanism
				Due to Real Target	Due to Fruit	
16K	-	-	None	-	None	None
32K			None	-	None	None
64K	1	1	-	-	τ2A	Fruit track in I <sub>+6</sub> 12.7 nmi @ 1635 knots
		2	200A		τ2A	Fruit track in I <sub>+6</sub> 9.3 nmi @ 2713 knots
		3	200A		None	None
96K	3	1		-	τ2B	Fruit track in I 11.8 @ 2286; 10.7 <sup>6</sup> @ 2589, 16 @ 1807
		2	200B	-	τ2B	Fruit track in I 15.7 @ 1303; 13.3 <sup>6</sup> @ 1392, 9.5 @ 2689
		3	200B	-	None	None
96K	1	1		-	τ2B	Fruit track in I <sub>-6</sub> 12.6 @ 2198
		2		-	None	None
		3	200B	-	τ2B	Fruit track in I <sub>-6</sub> 10.1 @ 2749
96K	1	1		-	τ2A	Fruit track in I <sub>+6</sub> 15 @ 2861
		2	200A	-	τ2A	Fruit track in I <sub>+6</sub> 13.1 @ 3886
		3	200A	-	None	None
96K	2	1		-	τ2A	Fruit track in I <sub>+6</sub> 13.9 @ 2500; 16.4 <sup>6</sup> @ 1623
		2		-	None	None
		3	200A	-	τ2A	Fruit track in I <sub>+6</sub> no print-out; 14.2 @ 4254

TABLE VIII-1. PHANTOM FALSE ALARMS  
IN LEVEL FLIGHT WITH NO INTRUDERS  
(CURVE 1 FIGURE VIII-1) (Cont.)

Fruit KPPS	No. of Occur- rences	Round	Pilot Display	Internal Threat Status		False Alarm Mechanism	
				Due to Real Target	Due to Fruit		
96K	1	1		-	τ2A	Fruit track in I+6 11.1 @ 2879	
		2		-	None		
		3	200A		-	τ2A	Fruit track in I+6 12.1 @ 2595
		4	200A		-	τ2A	Fruit track in I+6 11.5 @2731
		5	200A		-	None	

Summary	Fruit Rate PPS			
	16K/1536	32K/1536	64K/1536	96K/1536
Number of False Display	0	0	2	14
Number of Rounds	2250	2250	2250	2250
Test Duration in Hours	2	2	2	2
False Alarm Rate Per Hour	0	0	1	7

and the fruit mechanism which caused them. Referring to table VIII-1 there was one co-altitude TAU 2 threat below (72B) in which the threat was formed in the first round, missed in the second round, and formed in the third round, satisfying the two out of three display logic. This caused the output of a one round display of limit dive rate to 200 fpm (200 B). The threat in the first round was caused by formation of a phantom fruit track in the  $I_{.6}$  altitude response band at a range of 12.6 nmi and closing rate of 2193 knots and that in the third round by the same mechanism at 10.1 nmi and 2749 knots. There were three co-altitude TAU 2 threats below in which the threats were formed in the first and second rounds causing the 200 B to be displayed. The phantom pairs were formed at 11.8 nmi at 2286 knots, 15.7 at 1303 knots; 10.7 nmi at 2589 knots, 13.3 nmi at 1392 knots; 16 nmi at 1807 knots, and 9.5 nmi at 2689 knots.

The co-altitude TAU 2 threats above were similarly formed in the  $I_{.6}$  bands. There was one occurrence where the 200A threat was displayed twice in a row and one occurrence in which the 200A threat was displayed three times in a row. In the later case, fruit formed phantom tracks in the  $I_{.6}$  band in the first, third, and fourth rounds at supersonic closing rates. The possible effects which these phantom targets can have are multitudinous. If there are no real threats when they occur and the interrogating aircraft is in level flight, the effect is an unnecessary advisory to limit rate of ascent or descent. If there are no real threats and the interrogating aircraft is taking off from a terminal area and is climbing rapidly to get to cruise altitude, a limit rate of climb to 200 fpm command due to a phantom target is disruptive to the pilot, to the ATC system and may be hazardous to the large number of aircraft in the area (the phantom targets are the result of high fruit levels which result from a large population of aircraft in a concentrated area). The other commands resulting from phantom targets which limit rate of ascent or descent to 500, 1000, or 2000 fpm are disruptive to varying degrees when the aircraft is ascending or descending.

The principal cause of the formation of phantom TAU tracks was the use of range bins which became increasingly wider with increasing range (50 feet from 0 to 5 nmi, widening to 168 feet at 15 nmi) and the processing of TAU tracks involving phantom targets at supersonic closing rates. The latest AVOID I design as of 15 April 1975 uses 50 foot bins throughout the entire range, two out of two display logic, and does not process threats at supersonic closing rates since that is not a current requirement. Supersonic capability if required could be incorporated with very low phantom alarm rates by using round-to-round correlation in both range and range rate before processing threats through the display logic.

Curve 2 of figure VIII-1 represents the rate at which fruit induced phantom intruder alarms were generated when in a climb or dive flight profile between 500 and 1000 fpm (mode 2). The data used to generate this curve were derived from the test series used to generate curve 3 in which there was an actual P10 threat which masked the false P10 alarms. However,

the computer printout of the all-threats data, listed all of the threats (due to real targets and fruit) in every round regardless of what was fed to the display. Thus it was possible to analyze these data to determine the probability of developing phantom tracks in any of the threat bands. By noting that the probability of a  $\tau$ 2A threat ( $I_{+6} \cdot \bar{I}_{+13}$ ) or a P10 threat ( $I_{+13} \cdot \bar{I}_{+6}$ ) for a single round of seven sets was the same, the occurrence of the  $\tau$ 2A phantom tracks could be used equivalently to develop the P10 phantom alarm display rates. Thus the false alarms actually occurred as TAU 2A internal threats on a round-to-round basis. None appeared as a pilot display because of the two out of three logic requirement. However, P10 threats do not have the two out of three logic protection; thus the TAU 2A internal threats can be treated equivalently as P10 displays.

In table VIII-2, it is seen that at fruit rates up to and including 32K/1536, no phantom tracks were formed. However, at a fruit rate of 64K/1536, there were twenty  $\tau$ 2A internal alarms which were equivalent to ten phantom P10 displays. All but three of these  $\tau$ 2A tracks were formed at supersonic closing rates at between 8.3 and 16.4 nmi. It will be noted that the P10 type of threat utilized the one out of one display logic rather than the much more powerful two out of three display logic used for co-altitude threats. The one out of one enable/inhibit logic has been dropped in favor of a two out of two enable/inhibit logic for all future AVOID equipments which, together with other modifications, should insure a low false alarm rate.

#### CONDITIONAL ALARM ALTERATION DUE TO FRUIT

The test series designed by NAVAIRDEVGEN to generate the data for curve 3 of figure VIII-1 consisted of injecting a vertical rate signal into the AVOID corresponding to a climb rate of 700 fpm and then setting up an intruder at an altitude of 2000 feet above own altitude and at a fixed range of 0.3 mile where the bin widths are 50 feet. The one to two hour tests were run at each of three fruit rates: 16K/1536, 32K/1536 and 64K/1536 injected into the AVOID receiver along with the desired intruder. The proper display for own aircraft was limit climb rate to 1000 fpm. Analysis of the computer printouts of the decoded tapes revealed (table VIII-3) that the displayed commands were correct at a fruit rate of 16,000 pulses per second. However, at 32,000 pulses per second the limit climb rate to 1000 fpm display was altered to a 500 fpm display twice at different times during the 2 hour period and altered to a level-off command display twice in a row during the 2 hour period. At a fruit level of 64,000 pulses per second the alteration to a 500 fpm display occurred six different times during a one hour period, and the alteration to a level-off command occurred and was displayed three times, twice in a row. Each time fruit correlated in the  $I_{PCA}$  altitude band, producing a single PCA threat, the display logic

TABLE VIII-2. PHANTOM FALSE ALARMS  
IN ASCENDING FLIGHT AT 700FPM WITH NO INTRUDERS  
(CURVE 2 OF FIGURE VIII-1)

Fruit Rate PPS	No. of Occurrences	Round	Pilot Display	Internal Threat Status		False Alarm Mechanism
				Due to Real Target	Due to Fruit	
16K	-	-	None	-	None	None
32K	-	-	None	-	None	None
64K	20**	1	None	-	τ2A	Fruit track in I <sub>6</sub> ! 14.3 nmi @ 2897 kts 15.2 nmi @ 2583 kts 9.1 nmi @ 2355 kts 8.3 nmi @ 722 kts* 15.8 nmi @ 1605 kts 12.8 nmi @ 2358 kts 14.1 nmi @ 2464 kts 9.7 nmi @ 1842 kts 13.7 nmi @ 3738 kts 14.0 nmi @ 1179 kts* 15.6 nmi @ 1534 kts 15.7 nmi @ 1475 kts 14.8 nmi @ 1119 kts* 15.5 nmi @ 1451 kts 12.1 nmi @ 3448 kts 14.6 nmi @ 2849 kts 14.8 nmi @ 2962 kts 16.4 nmi @ 1664 kts 12.6 nmi @ 2778 kts 15.4 nmi @ 1481 kts
** Since the number of possible P10 rounds (6.5 seconds) in a 1 hour interval is half of the τ2A rounds (3.2 seconds), the number of equivalent P10 displays would be half of the internal τ2A threats which occurred. This would be equivalent to ten 1000A (limit climb rate to 1000 FPM) displays.						
* Subsonic Tracks						

Summary

	Fruit Rate - PPS		
	16K/1536	32K/1536	64K/1536
Number of Equivalent False Displays	0	0	10
Number of Rounds	894	1125	563
Test Duration in Hours	1.6	2.0	1.0
False Alarm Rate per Hour†	0	0	11

† Level Flight Phantom Alarms are a Subset

TABLE VIII-3. CONDITIONAL FALSE ALARMS  
IN ASCENDING FLIGHT AT 700 FPM WITH INTRUDER  
AT 2000 FEET (CURVE 3 OF FIGURE VIII-1)

Fruit KPPS	No. of Occur- rences	Round	Pilot Display*	Internal Threat Status		False Alarm Mechanism
				Due to Real Target	Due to Fruit	
16K	-	-	1000A	P10	None	None
32K	2	1	1000A	P10	None	None
		2	500A	P10	P5	Fruit Correlation with real target in I <sub>+6</sub> on 5th and 7th sets
		1	1000A	P10	None	None
		2	Level Off	P10	PCA	Fruit Correlation with real target in PCA on 5th and 7th sets
		3	Level Off	P10	None	None
		1	1000A	P10	None	None
64K	6	1	1000A	P10	None	None
		2	500A	P10	P5	Fruit Correlation with real target in I <sub>+6</sub> on 5th and 7th sets
		3	1000A	P10	None	None
		2	Level Off	P10	PCA	Fruit Correlation with real target in PCA on 5th and 7th sets
		3	Level Off	P10	None	None

\* Proper Command is 1000A (Limit Climb Rate to 1000 FPM).

Summary	Fruit Rate - PPS		
	16K/1536	32K/1536	64K/1536
Number of False Displays	0	4	12
Number of Rounds	1125	1125	563
Test Duration in Hours	2	2	1
False Alarm Rate per Hour	0	2	12

latched for two 6.5 second rounds resulting in the level off command being displayed for 13.0 seconds.

In interpreting this curve, it must be understood that it is a conditional probability curve that presupposes an aircraft in a threat status. It is thus quite different from the phantom intruder phenomena which does not presuppose an aircraft in a threat status.

The mechanism by which the commands are altered by fruit can be best explained by reference to the interrogation sequence diagram, figure I-5. When climbing at a vertical rate of 700 fpm the AVOID I interrogates with an  $I_{PCA}$  code which is shifted by 350 feet (30 seconds own altitude rate in feet per second). If an intruder aircraft is at an altitude differential of 1150 feet or less it will respond, and is considered a predicted coaltitude threat.

Since the climb rate exceeds 500 fpm, the interrogation of the  $I_{+13}$  band is enabled for set 1 and all subsequent sets of sequence 1 as long as a TAU threat exists on each subsequent set of interrogations. If the AVOID I were functioning correctly, it would interrogate with the  $I_{+13}$ ,  $I_{+6}$ , and  $I_{PCA}$  basic codes, develop a TAU track in the  $I_{+13}$  band and would not correlate in the  $I_{+6}$  or  $I_{PCA}$  bands on the 5th and 7th sets (the intruder at 2000 feet above should not fall within the  $I_{+6}$  band which has an upper boundary of +1350 feet nor the  $I_{PCA}$  band which has an upper boundary of +1150 feet at a vertical rate of 700 fpm). The resultant display should be a limit climb rate to 1000 fpm.

With fruit injected at rates of 32K/1536 and higher, occasionally fruit replies occupied the  $I_{+6}$  bands or the  $I_{PCA}$  band in the 5th and 7th interrogation sets within the acceptance gate located at the range of the intruder aircraft. This then caused the limit climb rate to 1000 fpm display to be altered to a limit climb rate to 500 fpm (if the fruit correlates in the  $I_{+6}$  band) or to a level off display (if the fruit correlates in the  $I_{PCA}$  band). The level off command persisted for two 6.5 second rounds when fruit correlated in the  $I_{PCA}$  band during one round evidently due to a display logic anomaly.

Similar alterations of commands occur when descending or when ascending at vertical rates greater than 1000 fpm which enables interrogation with the  $I_{+25}$  code. If the real target correlates in the  $I_{+13}$  or  $I_{+25}$  bands, and fruit correlates in the  $I_{PCA}$  bands, the threat logic output displays the more serious threat which is the predicted co-altitude threat with the level-off command. A tabulation of some of the possible command alterations due to fruit comprises table VIII-4.

Curve 4 of figure VIII-1 is the level flight conditional false alarm rate of the AVOID I given that own aircraft is in a TAU 1 alarm status.

TABLE VIII-4. CONDITIONAL ALARM ALTERATION MODES 2 AND 3

Interrogating Aircraft Vertical Rate - FPM	Intruder Aircraft Altitude Differential	Proper Command	Altered Command (Due to Fruit Correlation in the Branch Altitude Bands)	
>500 fpm	<2000 feet >1300 feet	LVS up 1000 fpm	LVS up 500 fpm	Level Off
>1000 fpm	<3200 feet >2200 feet	LVS up 2000 fpm	LVS up 1000 fpm	Level Off
<500 fpm	<2000 feet >1300 feet	LVS down 1000 fpm	LVS down 500 fpm	Level Off
<1000 fpm	<3200 feet >2200 feet	LVS down 2000 fpm	LVS down 1000 fpm	Level Off

The series of tests developed to generate the data for this curve consisted of operating the AVOID I in the level flight mode in the above 9500 ft altitude region, setting up a target at 0.15 nmi at an altitude differential of 800 feet above and conducting two hour tests at each of four different fruit rates: 16K/1536, 32K/1536, 64K/1536 and 94K/1536. If the AVOID did not correlate on fruit, it would display a dive command continuously. As shown in table VIII-5, it did just that at fruit rates up to and including 64K/1536. At the 96K/1536 rate, however, the dive command was altered in three instances to a dive command with a limit dive rate to 200 fpm and was altered in one instance to a dive command with a limit dive rate to 500 fpm. Table VIII-5 lists the type of alarm alterations, their duration in terms of number of rounds displayed, and the mechanism by which the alarm alterations occurred. In case 1, the dive command was altered to a dive limit rate of dive to 500 fpm on the third of three rounds. During the first round fruit correlated in the  $I_{-6}$  band on the 5th and 7th sets of interrogations which together with the real target in the  $I_{+6}$  band satisfied the logic for an equal altitude TAU 1 threat (EAL). During the second round, the fruit did not correlate or form a phantom track. However, in the third round, fruit occupied the range bins in the A through G registers of the  $I_{-6}$  band, formed a phantom track at 16.3 nmi at 1955 knots and in addition correlated in the E and G registers of the  $I_{-3}$  band. This satisfied the logic for an M5 threat which when combined with the EAL threat in the first round (2 out of 3 display logic) caused a limit dive rate to 500 fpm to be displayed along with the dive command.

In case 2, the dive command was altered to a still more restrictive command "dive but limit dive rate to 200 fpm" for two consecutive rounds. During the first round, fruit correlated in the  $I_{-6}$  band on the 5th and 7th sets of interrogations which together with the real target in the  $I_{+6}$  band satisfied the logic for an EAL threat. In the second round, fruit formed a phantom track in the  $I_{-6}$  band at 10.7 nmi at 2873 knots. This satisfied the logic to output a TAU 2 co-altitude threat below ( $\tau 2B$ ) which when combined with the EAL threat in the first round caused a limit dive rate to 200 fpm to be displayed along with the dive command for two rounds. Case 3 was similar to case 2 but only displayed the limit dive rate to 200 fpm once since there was no fruit correlated threat in between the EAL threat in the first round and the  $\tau 2B$  threat in the third round at 15.4 nmi at 1765 knots.

Thus the rate at which fruit alteration of a TAU 1 alarm occurred (given that a TAU 1 alarm was present) was 4 out of 2250 rounds or approximately 2 per hour.

#### CONDITIONAL ALARM ALTERATION DUE TO ALTITUDE SCALING FACTORS

The altitude scale factor of 1 nanosecond per foot, proved to be too critical to preserve the 100 foot digitizing accuracy of the altimeter in

TABLE VIII-5. CONDITIONAL FALSE ALARMS  
IN LEVEL FLIGHT, CO-ALTITUDE INTRUDER  
(CURVE 4 OF FIGURE VIII-1)

Fruit Pulses PPS	Round	Pilot Display*	Internal Threat Status		False Alarm Mechanism
			Due to Real Target	Due to Fruit	
16K		Dive	TA, T1A	-	None
32K		Dive	TA, T1A	-	None
64K		Dive	TA, T1A	-	None
96K (Case 1)	1	Dive	TA, T1A	EAL	Fruit Correlation with Real Target in I <sub>-6</sub> in 5th and 7th sets
	2	Dive	TA, T1A	-	None
	3	Dive 500B	TA, T1A	M5	Formation of Fruit Track in I <sub>-6</sub> @ 16.3 nm, 1955 kts and correlation in I <sub>-13</sub> in 5th and 7th sets
96K (Case 2)	1	Dive	TA, T1A	EAL	Fruit Correlation with Real Target in I <sub>-6</sub> in 5th and 7th sets
	2	Dive 200B	TA, T1A	T2B	Formation of Fruit Track in I <sub>-6</sub> @ 10.7 nm, 2873 kts
	3	Dive 200B	TA, T1A	-	None
96K (Case 3)	1	Dive	TA, T1A	EAL	Fruit Correlation with Real Target in I <sub>-6</sub> in 5th and 7th sets
	2	Dive	TA, T1A	-	None
	3	Dive 200B	TA, T1A	T2B	Formation of Fruit Track in I <sub>-6</sub> @ 15.4 nm, 1765 kts

\* Proper Display is a Dive Command

TABLE VIII-5. CONDITIONAL FALSE ALARMS  
 IN LEVEL FLIGHT, CO-ALTITUDE INTRUDER  
 (CURVE 4 OF FIGURE VIII-1) (Cont.)

Summary	Fruit Rate - PPS			
	16K/1536	32K/1536	64K/1536	96K/1536
Number of False Displays	0	0	0	4
Number of Rounds	2250	2250	2125	2250
Test Duration in Hours	2	2	2	2
False Alarm Rate Per Hour	0	0	0	2

establishing altitude threat boundaries. The system jitter which was primarily in the receiver was such that when altitude encoded interrogations were received, approximately 2% of the time the decoded interrogations were in error by 100 feet (and in a few instances by 200 feet). (Additional information on specific flights will be found in the flight narrative of this chapter.) Part of the problem stemmed from the fact the design goal was a receiver with 20 MHz bandwidth at the 3 dB points. System problems with regard to power budget, resulted in a receiver bandwidth of less than 10 MHz. Thus the ability to resolve the 1 nanosecond per foot was degraded. This resulted in a 100 to 200 foot zone of ambiguity at the altitude response band boundaries and caused the alteration of legitimate alarms. For example, in the above 9500 foot altitude regime, an intruder at an 800 foot altitude differential which should be identified as a co-altitude threat with a dive or climb command is sometimes decoded as being a 900 foot non co-altitude threat with a limit rate of ascent or descent to 500 fpm. The reverse situation also can occur where the intruder is at 900 feet, should be identified as a non co-altitude threat but instead is decoded as being at 800 feet and is classified as a co-altitude threat. Similar mechanisms occur at the upper boundary of the  $I_{+6}$  band which can cause classification of an intruder as above 1300 feet when in fact the intruder is below 1300 feet (or the reverse situation). Similarly, an uncertainty at the upper boundary of the  $I_{+13}$  band can cause classification of an intruder at above 2200 feet when in fact the intruder is below 2200 feet (or the reverse). Ambiguity in the  $I_{+4}$  boundary causes an intruder at an altitude differential of 500 feet to be identified as having a 400 foot altitude differential thus causing the interrogating aircraft to bias its responses by 200 feet in a direction opposite to the threat. The reverse situation can also occur.

Future AVOID I and AVOID II equipment will have 20 MHz bandwidth receivers and a 2 nanosecond per foot scaling factor to insure that altitude decoding is noncritical and to insure full compliance with the NAVAIRDEVCEEN AVOID II Requirements Document (appendix B) which requires that there be no zone of ambiguity at the altitude threat boundaries.

#### CONDITIONAL ALARM ALTERATION DUE TO A CO-RANGE SITUATION

In the situation where two aircraft are co-range with a third aircraft and occupy overlapping altitude response bands with respect to the third aircraft, alarms which have been correct in previous rounds could be altered resulting in a false display. Visualize a three aircraft encounter in which an aircraft A is at an altitude of 10,000 feet converging on aircraft B and C at altitudes of 10,500 and 11,000 feet, respectively. Assume that B and C have ranges to A which are within 300 feet of each other and that the TAU 1 threshold of B with respect to A has been exceeded. A correlates B in the  $I_{+6}$  altitude response band and since there is ample range separation between B and C, correlates C in the  $I_{+6}$  and  $I_{+13}$  altitude response bands. A thus determines that B is a co-altitude TAU 1

threat which supercedes C which is a non co-altitude threat < 1300 feet above. The threat logic outputs a dive command. Assume that one round later B and C's range to A become the same (co-range) and remains that way for the round. A now correlates B and C in the same range bins in the  $I_{+13}$  altitude response band, considers it one intruder and correlates C in the  $I_{+13}$ . A thus considers that it has a single intruder which is non co-altitude and less than 1300 feet above. Since the display logic requires two threats out of three to be the same, the effect that this round has had was to alter the internal threat status of the intruder but not the displayed dive command. If the co-range situation dwelled for another round (actually an unlikely event) the display would be altered to an incorrect alarm indicating a limit rate of ascent to 500 fpm rather than a dive command.

In a situation where aircraft A is at 10,500 foot altitude, converging on B and C at 10,000 and 11,000 foot altitudes, respectively, if B and C become co-range with A, A correlates B and C as one target in the  $I_{+6}$  and  $I_{-6}$  altitude response bands thus identifying the intruder as an equal altitude threat. If the co-range situation dwelled for two rounds it could cause alteration of a level off command to a dive or a climb command depending on the decision made by the tie breaking logic. It must be pointed out that these are very low probability events. To begin with a situation where three aircraft converge on each other with small vertical separations is a low probability event. This coupled with the low probability of two of the aircraft being co-range with a third aircraft in the crucial TAU 1 zone for more than one round results in a very low joint probability of alarm alteration.

To determine the AVOID I co-range resolution capability, laboratory tests were conducted using two targets in overlapping altitude bands each of which were generated from separate traffic simulators. The targets progressively were brought closer and closer to the same range until the AVOID was no longer able to distinguish the two separate intruders and thus failed to correlate the altitude bands correctly. The resolution was found to be between 100 and 200 feet.

In the flight test, co-range situations occurred during the three aircraft collision encounters. The AVOID I was able to resolve two intruders which were co-range within 100 to 200 feet. In those encounters in which the aircraft were co-range within 100 feet or less, the altitude correlation was incorrect for one round and altered the internal threat status of the intruders. However, in no case was the wrong command displayed to the pilot.

## FALSE ALARM FLIGHT NARRATIVE

The frequency of in-flight false alarms decreased after corrective actions by Honeywell midway through the flight tests; however, there still remained a significant number of such events, particularly those considered in the category of alarm alterations. For example, at or near the 1300 foot altitude separation, the boundary definition was not always firm. Thus, a 1300 foot TAU 2 above threat should be displayed as "limit climb to 500 feet per minute" (P-5). If it were displayed as "limit climb to 1000 feet per minute" (P-10), it was considered a conditional alarm alteration. The appearance of a target threat where none existed, due to excessive fruit, was categorized as a phantom intruder alarm. Occasionally, wrong threats at various critical altitude boundaries occurred intermittently for single rounds, but did not appear as wrong displays because of the 2 out of 3 display logic. The altitude boundary problem was scrutinized carefully during a special portion of flight 6 designed for this purpose. The P-3 flew repeated figure 8 patterns above the NC-117 with the NC-117 close behind (less than 0.5 mile separation). The flights were thus always in the TAU 1 zone at or near critical altitude separations such as 1300 and 800 feet above 10,000 feet. There were 14 altered displays out of a total of 2200. The percentage of altered displays was thus 0.63 percent. There were no phantom false alarms. All 14 altered displays occurred in the P-3 aircraft and for the same reason. The fruit in the NC-117 was 64K/1536. This means 64,000 fruit replies and 1536 interrogation quads above threshold. The fruit in the P-3 was 32K/1536. In a typical case, the NC-117 detected the P-3 target in the I<sub>16</sub> interrogation band which covers altitudes from -50 feet to +1350 feet. With the actual P-3 altitude separation being 700 feet, for example, the I<sub>13</sub> altitude correlation sequence of interrogations in the NC-117 covering altitudes from 850 to 2250 feet properly identified the P-3 target as co-altitude. However, the I<sub>14</sub> altitude correlation sequence (+450 feet to -950 feet) wrongly mistook fruit for the target and identified it as being within 400 feet above requiring the NC-117 to bias its own altitude 200 feet negatively. The NC-117 had the proper "dive" command but because of its negative bias appeared to be 900 feet below the P-3 instead of 700 feet below. The P-3 had no choice except to call the NC-117 an M5 threat (limit to 500 feet below) instead of displaying a "climb" command. The cause of the problem, in this flight, was a conditional wrong altitude correlation due to excessive fruit levels in the NC-117 aircraft. The problem would not have occurred at lower levels of fruit in the NC-117. It should be noted that in the AVOID I equipment flight tested, altitude correlation of a threat occurred in the 5th and 7th interrogation sets of the 7 set interrogation sequence.

Some of the false alarms occurring in the remaining communication reliability flights were those due to fruit looking like a supersonic threat, in the wider range bins generally beyond 8 miles. A typical

example in the communication reliability portion of flight 6 was a fruit target in the NC-117 (recall the high fruit rate 64,000 replies per second) at an apparent range of 48,000 feet and a range rate of 2500 feet per second giving a TAU of 19 seconds. This registered as a TAU 1 below threat for one round. This is an instance, however, where the 2 out of 3 requirement for display prevented a false alarm display from occurring. A supersonic capability had been built into the AVOID I equipment before the requirement for supersonic capability was dropped. Honeywell could have inhibited supersonic TAU tracks in this equipment but because of the complexity did not do so. Therefore, these supersonic fruit threats should not be assessed as faults. Should a supersonic capability be later required, the equipment could be built with the narrower 50 foot range bins all the way to maximum range. This would give a finer discrimination against false tracks due to random fruit. In the communication reliability portion of flight 6, there were 3 such instances of isolated rounds all in the NC-117 with its higher fruit level detecting a supersonic fruit track, none of which resulted in a pilot display. In addition, there were 6 altered rounds; e.g., T1A instead of P5, but no altered displays.

In flight 7, with fruit of 64K/1536 in both the P-3 and NC-117, there were 8 altered displays, 7 cases of unnecessary biasing, 17 isolated altered rounds not resulting in a wrong display, and one round having a phantom fruit target.

Flight 9 illustrated the altitude boundary problem due to the use of a scale factor of 1 nsec/foot. In the first encounter of this flight with the A-3 at 11,600 feet and the P-3 at 10,800 feet (800 foot separation should be co-altitude), the P-3 should have displayed a "dive" command. However, with the 1 nsec/foot scale factor, the A-3 replied to the P-3's  $I_{+13}$  interrogation set and was therefore declared to be a P-5 threat (limit climb to 500 feet per minute) instead of co-altitude. There were a total of 19 such altered displays in this encounter. A similar 1 nsec/foot resolution problem occurred during a portion of encounter 9 of this flight. With the A-3 1400 feet above the P-3 after taking evasive action, it was displayed by the P-3 as a P-5 threat three times instead of as a P-10 threat. In the remainder of the flight, there were only three isolated altered rounds in the P-3 with no altered displays. During encounter 13 of this three aircraft flight, the P-3 tracked the NC-117 perfectly at the 800 foot boundary below, indicating that the critical altitude gate adjustment in the NC-117 was probably better than that of the A-3. There were two instances of uncalled for altitude biasing in the P-3 with the A-3 500 feet above. The fault, again was in the A-3 altitude gate, since it should not have permitted a reply to the P-3's  $I_{+4}$  interrogation at 500 foot separation.

One of the isolated altered rounds in the P-3 was due to a co-range effect which did not persist long enough to result in a wrong display. The A-3 above was at the same range from the P-3 as the NC-117 below. Thus, the P-3 had a response to its  $I_{-6}$  interrogations at the same range as the response to the  $I_{-6}^{+6}$  interrogations. It had no choice but to interpret this as a single equal altitude target.

The A-3 displayed four P-10 and P-20 phantom fruit targets in the "unrestricted" test mode as false alarms during the encounters of this flight. All were of the supersonic range rate variety previously discussed. P-10's and P-20's do not have the benefit of the two out of three logic and are displayed for 6 seconds. In the normal mode of operation, these would not have occurred in level flight since higher altitude bands are not interrogated; however, the P-10's and P-20's could have occurred if the climb rate had been greater than 500 and 1000 fpm, respectively.

In the same three aircraft flight with the A-3 above the NC-117, the A-3 had four altered displays like M-10 instead of M-5, while the NC-117 had one altered display, a P-5 instead of a P-10.

The P-3 had no altered displays in this flight with respect to the NC-117. Neither did the NC-117 with respect to the P-3. There were two isolated altered rounds in the P-3 and one in the NC-117. Each aircraft had one instance of erroneous bias.

Another instance of altered displays at the 800 foot boundary occurred during encounter 11 of flight 11 at an angle between radials of 60 degrees. The A-3 was 800 feet above the P-3 and displayed the proper climb command. However, over a good portion of the TAU threat status interval, the A-3 replied to the  $I_{-6}$  altitude correlation interrogation set from the P-3 causing the P-3 to display a "limit climb to 500 feet per minute" (P-5 threat) instead of "dive" (TAU 1 threat). There were seven such altered displays in the P-3 aircraft. In addition, there were three isolated altered rounds in the P-3 and three in the A-3 without accompanying altered displays.

An even more consistent example of the altitude boundary problem occurred during several of the minus 90 degree encounters between the A-3 and NC-117 of flight 11. With the A-3, 1400 and sometimes 1500 feet above the NC-117, the A-3 had 50 wrong M-5 displays instead of the proper M-10 displays. Approximately concurrent with the A-3 altered displays, the NC-117 had 40 P-5 displays instead of the proper P-10 displays. This could be explained by poorly adjusted altitude gates in both the A-3 and the NC-117, or by a problem in the A-3 alone. Remember that the spacing between the first pulse pair and the second pulse pair of an interrogation has a factor of 1 nsec per foot for each altitude

band interrogated. If this spacing were off, the NC-117 would reply to the A-3's  $I_{-6}$  interrogation set (+50 to -1350 feet) when it should not, giving the A-3 wrong boundary indications. If, at the same time, the A-3's altitude gate adjustment was off, it would reply to the NC-117's  $I_{+6}$  interrogation set when it should not, giving the NC-117 wrong boundary indications. In any case, the wrong displays at the various altitude boundaries indicate the need for a less critical scale factor, e.g., 2 nsec per foot. The incidence of this type of altitude boundary problem between the P-3 and NC-117 in flight 11 was much lower, with only 1 case of an altered display in the NC-117.

Flight 12 between the A-3 and P-3 did not experience any altitude boundary or false alarm problems.

In summary, table VIII-6 shows that after some of the false alarm problems were solved the remaining communication reliability flights starting from flight 6, experienced approximately 133 conditional alarm alterations (altitude boundary problems) and ten phantom tracks, six of which were displayed in the unrestricted interrogation mode and four of which were isolated single round phenomena which were not displayed (high fruit, wide range bins, supersonic range rate problem). There were approximately 38 wrong rounds primarily due to the altitude boundary problem which did not result in wrong displays because of the two out of three round display criteria. A few were due to altitude fruit correlations. There were approximately 14 cases of unnecessary biasing contributing to altered rounds and altered displays at the opposite end of the link. The biasing was primarily due to problems in distinguishing the altitude boundaries of 400 feet by the  $I_{+4}$  altitude correlation sets of interrogations, e.g., an altitude separation of 500 feet was mistaken for 400 feet. On some occasions, fruit replies were correlated in the  $I_{+4}$  altitude correlation sets of interrogations and caused unnecessary biasing. To improve the altitude boundary definition, NAVAIRDEVCON recommended a 2 nsec per foot scale factor in place of the 1 nsec per foot.

Occasionally, an early alarm would result from a fruit track looking like a TAU 2 threat a round before a real threat appeared. The two rounds in succession satisfied the two out of three criteria and gave a display 3 seconds earlier than desired even though the two separate threats (one false and one real) were not related in range.

#### CONCLUSIONS

NAVAIRDEVCON considers the false alarm rate of a collision avoidance system crucial with respect to pilot acceptance and interaction with the air traffic control system. If a pilot who flies with a CAS sees that when he gets a CAS command it is real except for one 6.8 second false alarm

TABLE VIII-6. SUMMARY OF IN-FLIGHT FALSE ALARMS  
(PREDOMINANTLY LEVEL FLIGHT MODE 1)

	Number Of Alarms	Number Of Rounds	% Of Occurrence	False Alarm Rate Per Hour
Conditional Alarm Alteration Due To Altitude Scaling Factors And Fruit:				
Total All Categories	133	7373	2.0	20
Unnecessary Biasing	14	7373	0.2	2.
Phantom Intruder Alarms*	10	11,213	0.1	**

\*6 Alarms were displayed in the unrestricted interrogation mode (A test mode not used in normal operation) and 4 were isolated, single round occurrences which did not result in a display.

\*\*The phantom false alarm rate in the normal interrogation mode was zero.

in 1 year of flying (estimated to be 1000 hours for a full time pilot) he will build up confidence in the system. If on the other hand he gets several false commands in 1 day of flying, he will reject or ignore the system outputs. In a crowded terminal area, where the controllers are working at full capacity, false commands to the pilots which cause deviations from the flight path prescribed by the ground are disruptive and could be dangerous. For these reasons, NAVAIRDEVCCEN believes that false alarms should be confined to a rate in the range of 1 to 10 per 10,000 hours in the 1982 Los Angeles basin traffic model.

On this basis, it is seen from the test results, that the false alarm rate of the AVOID I delivered for evaluation was unacceptable. After a month and a half of laboratory testing of the AVOID I CAS, NAVAIRDEVCCEN considered the false alarm rate unsatisfactory and initiated a series of technical interchanges with Honeywell concerning the reduction of false alarms. During the flight test program several changes were made which alleviated somewhat the alarm alteration due to scaling factors but fell short of being satisfactory. In so far as false alarms due to fruit were concerned, the changes required were not feasible since they would have required a major redesign.

At about this time, NAVAIRDEVCCEN was preparing an RFQ for the AVOID II CAS for low performance aircraft. Integral with the contract was a NAVAIRDEVCCEN Requirements Document (appendix B) which delineated the performance criteria which had to be met. Incorrect alarms due to faulty translation of the digitized altimeter outputs on either the interrogating or transponding end of the data links were specified at a zero rate. False alarms due to fruit equivalent to the FAA 1982 Los Angeles Basin Traffic Model were specified as follows: TAU 2 less than one per 1000 hours, TAU 1 less than one per 10,000 hours.

To meet these requirements the AVOID II and future AVOID I designs incorporate many changes:

1. Modes 1, 2 and 3 all incorporate the same fruit suppression logic.
2. TAU tracks are correlated on eight sets of interrogations instead of seven.
3. Branch altitude responses are correlated on five sets of interrogations per round rather than two sets (actually, since two consecutive rounds are required to satisfy the display logic, correlation must take place in the branch altitude band 10 times as opposed to twice in modes 2 and 3 of the AVOID I CAS (version 1) which was evaluated.
4. The display logic only outputs a threat, if a TAU track persists in two successive rounds, correlated in range from the 8th set of the

first round to the 1st set of the second round. The AVOID I (version 1) utilized an any two of three round logic with no range correlation for mode 1 and no round-to-round logic or range correlation in modes 2 and 3.

5. The altitude scaling factor is 2 nanoseconds per foot instead of the 1 nanosecond per foot in the AVOID I (version 1) to preclude translation errors of the altimeter digitized output at the interrogating and responding ends of the data link.

To further enhance the system fruit suppression capabilities, and provide inherent growth capabilities to supersonic closing rates and/or greater power budget margins, range rate correlation should be incorporated into the two consecutive round display logic.

In order to increase the fruit margin even further, consideration should be given to changing the interrogation: 500, 600 nsec quadruplet to a 500, 700 nsec; 600, 800 nsec sextuplet as shown in figure VIII-2. This would essentially eliminate the possibility of fruit pulses combining with the first pulse of the first pulse pair or the first pulse of the second pulse pair to form a faulty interrogation code which could result in a conditional alarm alteration or lost alarm.

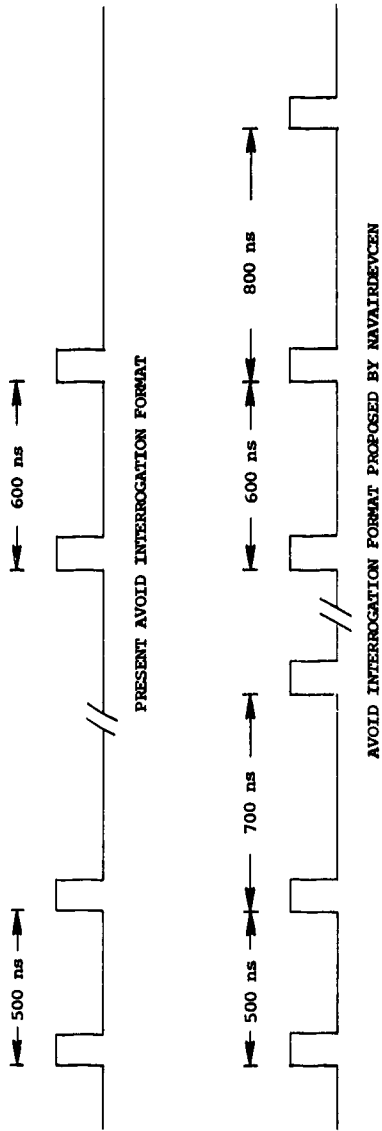

Figure VIII-2. Present and Proposed Interrogation Format.

## CHAPTER IX

## SUMMARY OF RESULTS

The AVOID I provided the necessary avoidance warnings to the pilots. The warnings were consistent with the requirements of ANTC 117, and provided the pilots with sufficient time to execute the necessary avoidance maneuvers.

The required communication range was exceeded for all encounter angles at the speeds flown, and for all extrapolated 1200 knot range rates above 10,000 feet for all of the 10 flights involving the NC 117 vs. either the RA-3B or P-3. The same results were achieved for all of the flights involving the RA-3B above the P-3. For the flights involving the P-3 above the RA-3B, the communication ranges were marginal when extrapolated to a 1200 knot range rate, above 10,000 feet, at encounter angles of -120 and 180 degrees.

The round and display reliability were both satisfactory from the communication point of view as shown in the chart below:

RELIABILITY	BEFORE TAU 2	TAU 2 (ADVISORIES)	TAU 1 (COMMANDS)	TAU 1 AND TAU 2	ALL
Round*	0.953	0.958	0.978	0.963	0.959
Pilot Display	--	0.977	0.997	0.982	--

\*Time between "looks" at the same target

From the above it can be seen that the total round reliability for all the communication reliability flights, for all aircraft and for all types of rounds was 95.9 percent, based on 11,213 three-second round opportunities. By round type, the reliability was 95.3 percent before the TAU 2 threshold was reached, 95.8 percent for TAU 2, 97.8 percent for TAU 1 and 96.3 percent for combined TAU 1 and TAU 2 rounds.

The total display reliability for all communication reliability flights, for all aircraft and for all TAU 1 and TAU 2 displays was 98.2% based on 7373 three-second display opportunities. By display type, the reliability was 97.7 percent for TAU 2 and 99.7 percent for TAU 1. The approximate 1.9 percent improvement in combined TAU 1 and TAU 2 display reliability, compared to the combined TAU 1 and TAU 2 round reliability was due to the use of a 2 out of 3 display acquisition and retention logic for threats within  $\pm 1300$  feet of altitude. These reliability results were obtained with up to 9 db of additional external attenuation in the RF link, and fruit above threshold ranging up to 64,000 replies and 1536 interrogation quads per second in each aircraft. The round and display reliability numbers given reflect the effect of lost rounds and displays only. If altered alarms due to fruit and altitude scale factors are included the reduction in display reliability is approximately 2%. Phantom trac's (a track where no real threat existed) constituted approximately 0.1% of the rounds during flight.

The air-to-air data link, used to determine the altitude threat band of an intruder, had an error rate which was the principal source of false alarms. In flight, the criticality of the altitude scale factor accounted for most of the altered alarms. Extensive laboratory tests established the phantom and altered alarm rates exclusive of the altitude scale factor, under controlled conditions which were impractical during flight. At predicted fruit rates the altitude correlation logic was insufficient to preclude the alteration of an alarm. This was a conditional type of false alarm dependent on the existence of a real target threat. A serious false alarm of this type was the alteration of a "limit vertical speed to 1000 fpm" advisory to a "level off" command. This occurred at a rate of three times per hour at altitude rates greater than 500 fpm with an intruder at an altitude differential of 2000 feet. Each time it persisted for 13 seconds (two rounds) with fruit at 64 K/1536. (The first number, in the fruit notation, is the fruit replies per second and the second number is the interrogation quads received per second.)

There was a second category of false alarms not conditional upon the presence of a threat. These were caused by the formation of phantom intruders from high density fruit. They occurred in the wide range bins near the maximum range of the equipment at supersonic closing rates.

NADC-75056-60

The overall displayed false alarm rates at varying fruit rates are tabulated below:

FRUIT RATE	LEVEL FLIGHT		500fpm<CLIMB OR DIVE<1000fpm	
	TAU 1 ALARM ALTERATIONS (CONDITIONAL) PER HOUR	TAU 2 PHANTOM INTRUDERS PER HOUR	TAU 2 ALARM ALTERATIONS (CONDITIONAL) PER HOUR	TAU 2 PHANTOM INTRUDERS PER HOUR
32K/1536*	0	0	2	0
64K/1536**	0	1	12	11
96K/2550	2	7	--	--

\* Predicted fruit rate in accordance with computer simulation of 1982 Los Angeles Basin Traffic Model (Appendix A).

\*\* Recommended fruit rate in Appendix A (approximately twice the predicted fruit rate).

The range and range rate accuracies (Theodolite reference) were:

GROUP	RANGE		RANGE RATE	
	MEAN % OF RANGE	SIGMA FEET	MEAN KNOTS	SIGMA KNOTS
All Data	+2.5	154	+10	11
Data Without Fruit	+2.7	132	+9	10
Data With Fruit*	+2.1	197	+13	13

\*Predicted fruit rate in Appendix A.

The errors with fruit were small and provided warning times in close agreement with ANTC-117.

The warning time mean and standard deviations expressed as percentages of the TAU TWO and TAU ONE thresholds (Theodolite reference) were:

TAU ONE	TAU TWO
$\mu = +0.4\%$	$\mu = +0.5\%$
$\sigma = 4.1\%$	$\sigma = 4.1\%$
$N = 47$	$N = 48$

From the above it can be seen that the TAU TWO warnings provided by the AVOID were on the average 0.5% earlier than the threshold with a standard deviation of 4.1% from threshold. The TAU ONE warnings were on the average 0.4% earlier than the threshold with a standard deviation of 4.1% from threshold.

At the Dover, Delaware, VORTAC site, the warning time history of 356 TAU TWO in-flight alarms and 312 TAU ONE in-flight alarms were compiled. For closing rates greater than 100 knots, at a 90% confidence level, 94.1% of the TAU TWO alarms occurred within 3.4 seconds of an upper and lower boundary of  $\pm 8.2\%$  of threshold and 94.2% of the TAU ONE alarms occurred within 1.6 seconds of an upper and lower boundary of  $\pm 8.2\%$  of threshold. The round time for all TAU ONE and TAU TWO co-altitude commands, predicted co-altitude commands and non-co-altitude advisories within a  $\pm 1300$  feet altitude differential was a fixed  $3.2 \pm 0.2$  seconds. Predicted co-altitude commands and non-co-altitude advisories at altitude differentials greater than  $\pm 1300$  feet had a fixed  $6.5 \pm 0.2$  second round time.

During the flight test program, analysis of the in-flight data revealed the formation of phantom targets below own aircraft due to multipath. This effect was corrected by providing an altitude interrogation response guard gate ahead of the altitude acceptance gate to inhibit the acceptance gate upon receipt of a multipath interrogation.

NADC-75056-60

REFERENCES

1. Interagency Agreement DOT-FA 73 WAI-358 Between FAA and NAVAIRDEVCEN for the Technical Evaluation and Test Program of AVOID CAS dated October 1973.
2. NAVAIRDEVCEN Contract N62269-73-C-0487 of 22 January 1973 With Honeywell.
3. Air Transport Association of America ANTC Report No. 117, Revision 10, of 27 September 1971 - Airborne Collision Avoidance Requirements.
4. NAVAIRDEVCEN Flight Test Plan for AVOID CAS With Vertical Maneuver Escape Logic Code 20-6 of 21 March 1974.

NADC-75056-60

BIBLIOGRAPHY

1. AVOID I Collision Avoidance System - Theory of Operation (1974) - Honeywell Government and Aeronautical Products Division.
2. Honeywell Proposal E7231-RD of 6 September 1972 AVOID I Collision Avoidance System for NADC.
3. AVOID I Operating Instructions YG1132A01 of 1 April 1974.
4. Honeywell Proposal E7417-RD of 31 May 1974 AVOID II Collision Avoidance System for NADC.
5. AVOID I Specification HRS 24707-01 of 28 December 1973.
6. AVOID Digital Display and Interface Specification HRS 24709-01 of 17 December 1973.
7. AVOID Traffic Simulator Specification HRS 24708-01 of 17 December 1973.

## APPENDICES

Appendix	Title	Page
A.	Honeywell Customer Engineering Letter of April 3, 1974 - AVOID I Interrogation and Fruit Rates .....	A-1
B.	NAVAIRDEVCEEN Requirements for AVOID II Collision Avoidance Equipment Code 6071 of 18 June 1974 .....	B-1
C.	Honeywell Customer Engineering Letter NADC-74-2 of October 4, 1974 - Post Shipment Modifications of the AVOID I .....	C-1
D.	Computer Print-Out for Parallel Overtake of the NC-117 by the P-3A (2 NMI Offset) on Theodolite Range .....	D-1
E.	Computer Print-Out for Tail Chase of the NC-117 by the P-3A (150 Knots) on Theodolite Range .....	E-1
F.	Computer Print-Out for Head-On Encounter Between NC-117 and P-3A (330 Knots) on Theodolite Range .....	F-1
G.	Computer Print-Out for Head-On Encounter Between RA-3B and P-3A (550 Knots) on Theodolite Range .....	G-1
H.	Computer Print-Out for Head-On Encounter Between RA-3B and P-3A (850 Knots) on Theodolite Range .....	H-1
I.	Range and Range Rate Error Sub-Group Statistics (Theodolite Reference Standard)..	I-1
J.	Derivation of the Probability Density Function (PDF) and Cumulative Density Function (CDF) for the Aircraft Getting the Alarm First in Each Alarm Pair .....	J-1
K.	Computer Print-Out for Three Aircraft Encounter - P-3 Print-Out of A-3 Above, NC-117 Below Miss Distances <2000 Feet (Dover, Delaware VORTAC Site) .....	K-1

APPENDICES (Continued)

Appendix	Title	Page
L.	Computer Print-Out for Three Aircraft Encounter P-3 Print-Out of A-3 Above, NC-117 Below A-3 and NC-117 Co-Range With P-3 (Dover, Delaware VORTAC Site) ...	L-1
M.	Computer Print-Out for Three Aircraft Encounter P-3 Print-Out of A-3 Above, NC-117 Below - NC-117 Oscillating Around the 800 Ft. Co-Altitude Boundary (Dover, Delaware VORTAC Site) .....	M-1

NADC-75056-60

APPENDIX A

Honeywell Customer Engineering Letter  
of April 3, 1974  
AVOID I Interrogation and Fruit Rates



GOVERNMENT & AERONAUTICAL  
PRODUCTS DIVISION  
MINNEAPOLIS OPERATIONS

NADC-75056-60

C.E.L. NO.

DATE April 3, 1974

PAGE 1 OF 12

## CUSTOMER ENGINEERING LETTER

Mr. James L. Hinds  
Command and Control Division  
Naval Air Development Center  
Department of the Navy  
Warminster, Pa. 18974

Subject: AVOID-I INTERROGATION AND FRUIT RATES

### SUMMARY

Honeywell Inc. has conducted a study to determine the interrogation and fruit rates expected in the L.A. Basin in 1982.

The baseline air traffic model used was Snapshot 1 as given in the Mitre Corporation Report<sup>1</sup>. Snapshot 1 contains 743 aircraft. Calculations normalized to 800 aircraft are also included.

The basic analytic approach was to treat each aircraft in the model on an individual basis. The computer was used extensively due to the large number of calculations involved.

All IFR aircraft were assumed to be equipped with the AVOID-I CAS (ANTC-117 threat criteria).

VFR aircraft were assumed to be equipped with the AVOID-II CAS that is to be delivered to NADC<sup>2</sup>. The AVOID-II is designed for General Aviation aircraft that operate under 10,000 feet.

The resulting mix of CAS equipment is approximately 15 percent AVOID-I and 85 percent AVOID-II.

The expected fruit rates over the LA terminal and at a point +15 miles east and 10 miles south of the terminal were calculated. The latter position is at the approximate center of the most dense air traffic.

Average interrogation rates (transmitted and received) for the AVOID-I and AVOID-II were also calculated.

As a result of the study, Honeywell recommends the following traffic simulator settings when conducting traffic handling tests on the AVOID-I CAS. These settings significantly exceed the predicted fruit and interrogation rates.

<u>FRUIT RATE</u>	<u>INTERROGATION RATE</u>
64,000	1536 (20% requiring responses)

<sup>1</sup> "Statistics Summary of the 1982 Los Angeles Basin Standard Traffic Model", April 1973, MTR-6387.

<sup>2</sup> RFP N62269-74-R-0674.

/Cont'd...

The estimated fruit rate (See Section D) for an AVOID-I with loop sensitivity of 129dB is 36,732 pulses per second when the AVOID-I is operating in the most dense air traffic in the LA Basin model.

The estimated received interrogation rate is 1261 interrogations received per second under the same conditions.

A. INTRODUCTION

The average fruit rate received by an AVOID receiver can be estimated if the interrogation and response rates of all aircraft within communication range are known. The following figure identifies the parameters that must be determined.

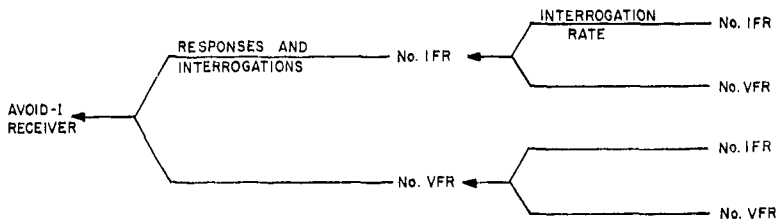

The AVOID-I receiver under question receives responses and interrogations from a given number of IFR and VFR aircraft (AVOID-I and AVOID-II). The number of fruit pulses transmitted by each aircraft is determined by the number of interrogations each receives. This is stated in equation form below:

AVOID-I FRUIT EQUATION

$$\begin{aligned}
 & (\text{NO. AVOID-I RESPONDERS})(\text{AVERAGE NO. AVOID-I INTERROGATORS}) \frac{R_1}{5} \\
 + & (\text{NO. AVOID-I RESPONDERS})(\text{AVERAGE NO. AVOID-II INTERROGATORS}) \frac{R_2}{5} \\
 + & (\text{NO. AVOID-II RESPONDERS})(\text{AVERAGE NO. AVOID-I INTERROGATORS}) \frac{R_1}{5} \\
 + & (\text{NO. AVOID-II RESPONDERS})(\text{AVERAGE NO. AVOID-II INTERROGATORS}) \frac{R_2}{5} \\
 + & (\text{NO. AVOID-I})4R_1 + (\text{NO. AVOID-II})4R_2
 \end{aligned}$$

The last two terms in the equation account for interrogations received during the "listening period" by the receiver for which fruit is being calculated.

The  $R_1$  and  $R_2$  terms are the average interrogation rates of the AVOID-I and AVOID-II respectively. The interrogation rates are divided by 5 because the AVOID CAS responds to approximately 1/5 of the interrogations received.

**B. AVERAGE TRANSMITTED INTERROGATION RATES**

The interrogation rate depends on the interrogation decision logic and threat status. A computer program was written to determine the threat status of each aircraft in Snapshot 1.

The programmed threat criteria for all air carriers was identical to ANTC-117 requirements. The threat criteria, altitude bands and interrogation schedule for all General Aviation aircraft (VFR) is given below:

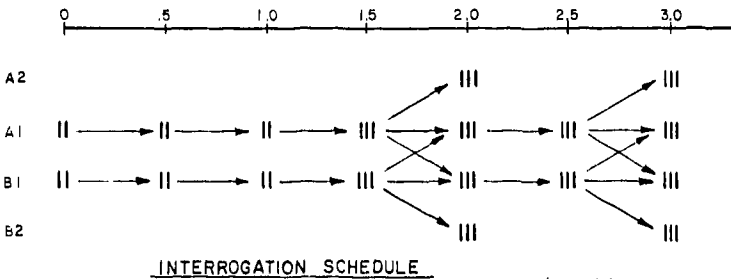
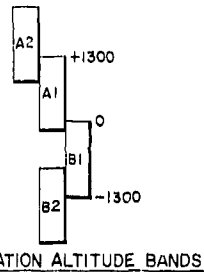
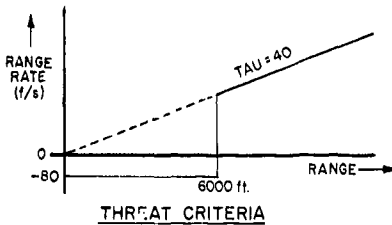

/Cont'd...

The interrogation rate for each air carrier was determined by correlating the threat status and interrogation decision logic as given in Figures 5 and 6 of the AVOID-I OPERATING INSTRUCTIONS (reproduced in this document for easy reference) hand-book. The interrogation decision logic applied assumed that the air carrier was not violating the displayed advisory. For example, if a limit climb to less than 500fpm advisory was displayed the I(+13) and I(+25) interrogations were not counted. The results for all air carriers in snapshot 1 are summarized below:

AVOID-I

	<u>NO. A/C</u>	<u>TOTAL INTERROGATIONS (6.4 sec)</u>
A/C WITH NO THREATS	14	396
A/C WITH ONE OR MORE THREATS	16	1644
TOTAL	<u>30</u>	<u>2040</u>

$$\text{AVERAGE INTERROGATION RATE} = \frac{2040}{30(6.4)} = 10.6$$

PER SECOND

This interrogation rate was assumed for all IFR aircraft in subsequent calculations.

A similar correlation of threat status and interrogation decision logic for the 689 GA aircraft was completed. The results are tabulated below:

AVOID-II

	<u>THREAT IN A1 OR B1 BAND ONLY</u>	<u>THREAT IN BOTH A1 AND B1 BANDS</u>	<u>A/C WITH NO THREATS</u>
NO. INTERROGATIONS IN 3.2 SECONDS	36	48	12
NO. AIRCRAFT	137	146	406

TOTAL NO. OF INTERROGATIONS = 16812

$$\text{AVERAGE NO. OF INTERROGATIONS} = \frac{16812}{(689)(3.2)} = 7.9$$

The same analysis of all GA aircraft within a 10 mile radius of the LA terminal resulted in a calculated average interrogation rate of 8.3 interrogations per second. The 8.3 number was used in subsequent calculations.

C. AVERAGE COMMUNICATION RANGES

The baseline AVOID power and sensitivity are summarized below:

AVOID POWER BUDGET SUMMARY (BASELINE DESIGN)

	<u>POWER TRANSMITTED (EACH ANT.)</u>	<u>RECEIVER SENSITIVITY</u>
AVOID-I	58dBm	-71dBm
AVOID-II	55dBm	-68dBm

The power budget was chosen to obtain near equal gain margins for all communication links.<sup>4</sup> The baseline communication link parameters are listed below:

<u>XMITTER</u>	<u>RECEIVER</u>	<u>REQUIRED RANGE(FT)</u>	<u>PATH LOSS(dB)</u>	<u>LOOP SENSITIVITY(dB)</u>	<u>GAIN MARGIN(dB)</u>	<u>AVG. COMM. RANGE (mi)</u>
AVOID-I	AVOID-I	52,600	121	129	8.0	17
AVOID-I	AVOID-II	43,500	119.5	126	6.5	12
AVOID-II	AVOID-I	43,500	119.5	126	6.5	12
AVOID-II	AVOID-II	25,600	115.0	123	8.0	8.4

By increasing the transmitted power of each AVOID transmitter (each antenna) by 2dB the average communication range increases to the values given in the following table:

COMMUNICATION LINK PARAMETERS (+2dB)

<u>XMITTER</u>	<u>RECEIVER</u>	<u>REQUIRED RANGE(FT)</u>	<u>PATH LOSS(dB)</u>	<u>LOOP SENSITIVITY(dB)</u>	<u>GAIN MARGIN(dB)</u>	<u>AVG. COMM. RANGE (mi)</u>
AVOID-I	AVOID-I	52,000	121	131	10.0	21.4
AVOID-I	AVOID-II	43,500	119.5	128	8.5	15.1
AVOID-II	AVOID-I	43,500	119.5	128	8.5	15.1
AVOID-II	AVOID-II	25,600	115.0	125	10.0	10.6

The IDA<sup>3</sup> report estimated that the average communication range between two AVOID-I systems with 129dBm loop sensitivity to be 17nmi when using the antenna patterns of a Boeing 737 which has a forward gain of 3dB. The same report estimated that communication range between two AVOID-II systems with 126dB loop sensitivity and omnidirectional antenna patterns to be 12nmi. Since the baseline AVOID-II loop sensitivity is 123dBm (required range was reduced to 25,600 ft), the average communication range between two AVOID-II systems is 8.4nmi.

The AVOID-I to AVOID-II communication range was estimated by Honeywell to be 12nmi (loop sensitivity of 126dB). This assumes omnidirectional antenna patterns on both aircraft.

D. AVERAGE FRUIT AND INTERROGATIONS RECEIVED

A computer program was written to determine the number of aircraft (snapshot 1) in communication given the communication ranges listed in Section C. The program was modified twice as shown below:

<u>CENTER</u>	<u>COMM. RANGE</u>
LA TERMINAL	BASELINE
15 MI EAST, 10 MI SOUTH	BASELINE
15 MI EAST, 10 MI SOUTH	+2dB to LOOP SEN.

The number of aircraft in communication is summarized in the following charts.

<sup>3</sup> "A review and analysis of the Honeywell Collision Avoidance System", IDA Study S-424 Oct. 1973.

<sup>4</sup> The AVOID-I flight test models have the same loop sensitivity (transmitted power = 55dBm, Receiver sensitivity = -74dBm)

NUMBER OF AIRCRAFT IN COMMUNICATION

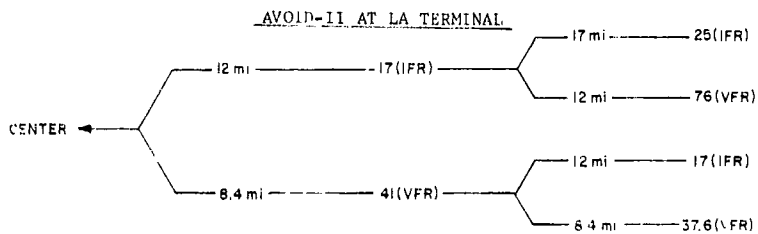
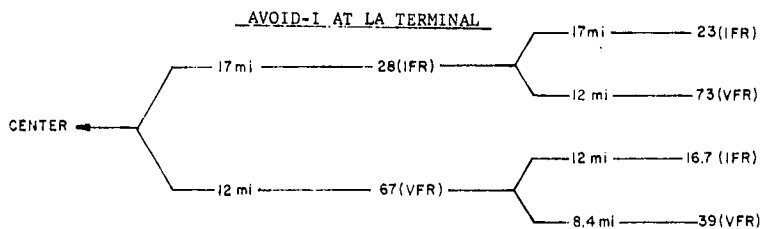

AVOID-I AT 15 MI EAST, 10 MI SOUTH

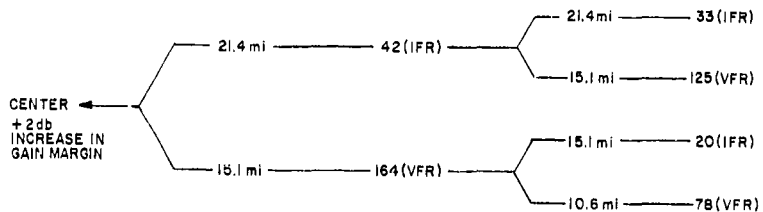
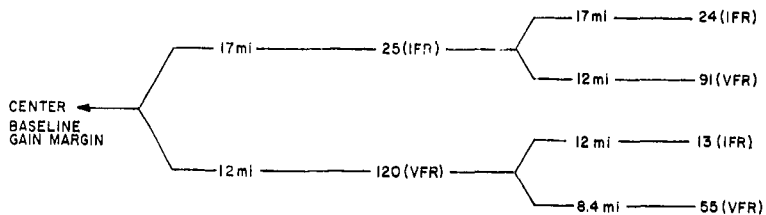

AVOID-II AT 15 MI EAST, 10 MI SOUTH

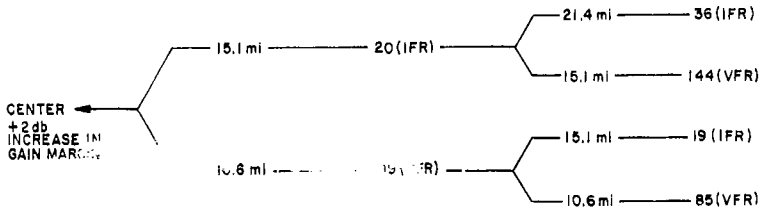
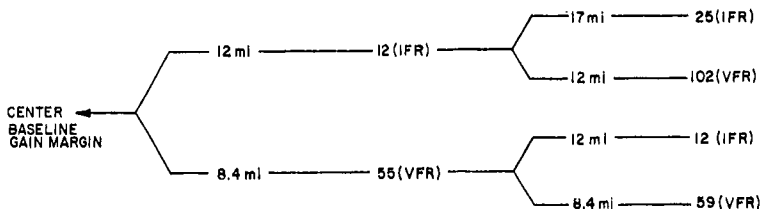

SAMPLE CALCULATION OF AVOID-I FRUIT AND INTERROGATION RATE

[RESPONSES RECEIVED (15 MILES EAST, 10 MILES SOUTH)]

$$\frac{1}{5} [25(24)(10.6) + 25 (91)(8.3) + 120 (13)(10.6) + 120 (55)(8.3)]$$

Responses Received = 19,311

INTERROGATIONS RECEIVED

$$25 (10.6) + 120 (8.3) = 1261$$

TOTAL FRUIT RECEIVED

$$[19,311 + 4(1261)] 1.3 = 31,666 \text{ Fruit Pulses/Sec.}$$

The interrogations received are multiplied by 4 because each interrogation contains 4 pulses. The 1.3 factor accounts for an average multipath reception rate of 30 percent. The 1/5 factor is included because only approximately 1/5 of the interrogations received require a reply.

The following table summarizes the results of the study. The last column is normalized to 800 aircraft. The interrogation rate calculated from air carriers was used for all IFR aircraft.

The average communication range of the baseline system is considered adequate for operation below 10,000 feet. For flight tests Traffic Simulator settings of 64,000 fruit pulses per second and 1536 interrogations per second with 20 percent requiring responses will provide sufficient excess fruit and transponder blockage to provide confidence in the test results.

The increased loop sensitivity of AVOID-1's operating above 10,000 feet (+4db transmitter power) from each antenna was not included in the calculation of number of aircraft in communication. These aircraft will require very few responses that contribute to fruit.

C.P. Harman  
C.P. Harman  
Project Engineer

L. Jordan  
L. Jordan  
Principal Development Engineer

SUMMATION OF FRUIT AND INTERROGATIONS RECEIVED

CAS	CLAIM	POWER BUDGET	INTERROGATIONS RECEIVED	RESPONSES RECEIVED	TOTAL PULSES REC.	TOTAL FRUIT INCL. MULTIPATH	FRUIT NORMALIZED TO 800 A/C.
AVOID-I	LA. BASIN	BASELINE	853	11,467	14,878	19,342	22,436
AVOID-I	EAST SOUTH 15 10	BASELINE	1261	19,311	24,358	31,666	36,732
AVOID-I	EAST SOUTH 15 10	+2dB	1808	39,841	47,065	61,184	70,974
AVOID-II	LA. BASIN	BASELINE	520	7,082	9,164	11,507	13,819
AVOID-II	EAST SOUTH 15 10	BASELINE	582	9,526	11,855	15,133	17,748
AVOID-II	EAST SOUTH 15 10	+2dB	1034	24,264	28,39	36,119	42,826

NADC-75056-60

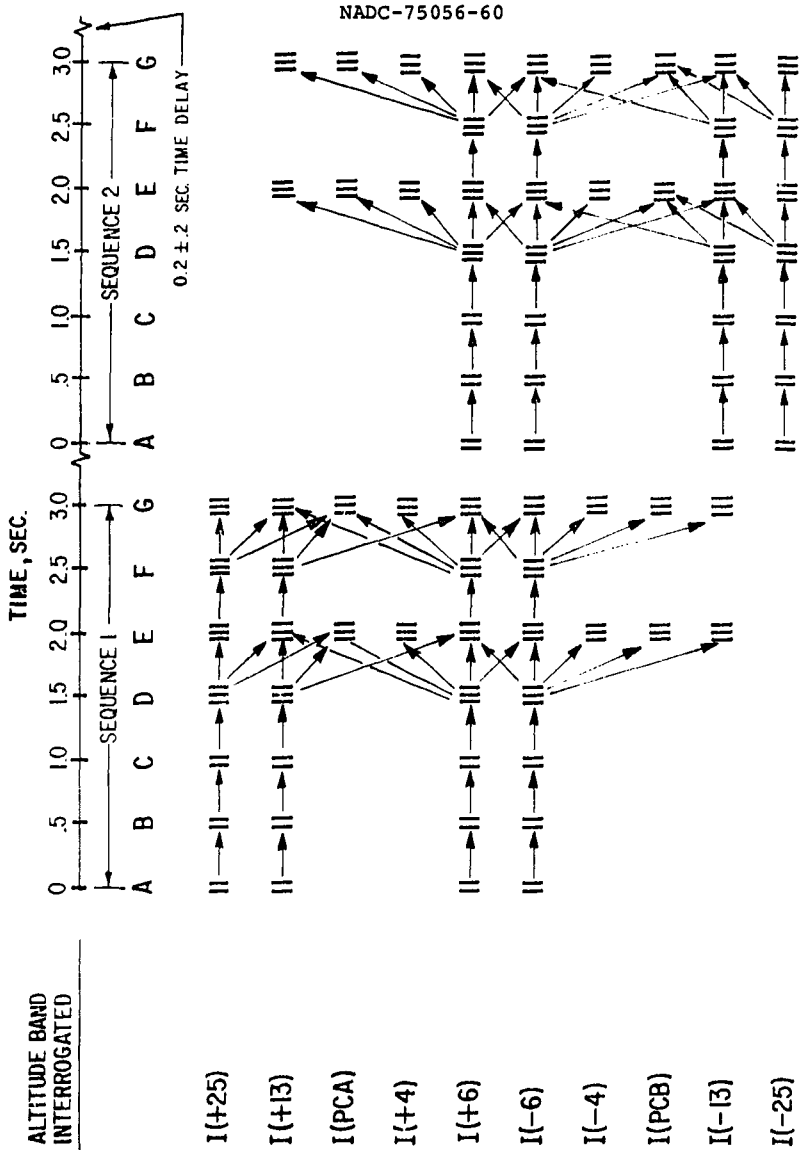

NOTES: I —→ DENOTES INTERROGATION IFA THREAT EXISTS

FIG. 5 INTERROGATION SEQUENCE

NADC-75056-60

ADDRESS	SEQUENCE I						SEQUENCE II						
	SET A	SET B	SET C	SET D	SET E	SET F	SET A	SET B	SET C	SET D	SET E	SET F	SET G
1(000)	0(000)	0(000)	0(000)	0(000)	0(000)	0(000)	0(000)	0(000)	0(000)	0(000)	0(000)	0(000)	0(000)
1(001)	0(000)	0(000)	0(000)	0(000)	0(000)	0(000)	0(000)	0(000)	0(000)	0(000)	0(000)	0(000)	0(000)
1(002)	0(000)	0(000)	0(000)	0(000)	0(000)	0(000)	0(000)	0(000)	0(000)	0(000)	0(000)	0(000)	0(000)
1(003)	0(000)	0(000)	0(000)	0(000)	0(000)	0(000)	0(000)	0(000)	0(000)	0(000)	0(000)	0(000)	0(000)
1(004)	0(000)	0(000)	0(000)	0(000)	0(000)	0(000)	0(000)	0(000)	0(000)	0(000)	0(000)	0(000)	0(000)
1(005)	0(000)	0(000)	0(000)	0(000)	0(000)	0(000)	0(000)	0(000)	0(000)	0(000)	0(000)	0(000)	0(000)
1(006)	0(000)	0(000)	0(000)	0(000)	0(000)	0(000)	0(000)	0(000)	0(000)	0(000)	0(000)	0(000)	0(000)
1(007)	0(000)	0(000)	0(000)	0(000)	0(000)	0(000)	0(000)	0(000)	0(000)	0(000)	0(000)	0(000)	0(000)
1(008)	0(000)	0(000)	0(000)	0(000)	0(000)	0(000)	0(000)	0(000)	0(000)	0(000)	0(000)	0(000)	0(000)
1(009)	0(000)	0(000)	0(000)	0(000)	0(000)	0(000)	0(000)	0(000)	0(000)	0(000)	0(000)	0(000)	0(000)
1(010)	0(000)	0(000)	0(000)	0(000)	0(000)	0(000)	0(000)	0(000)	0(000)	0(000)	0(000)	0(000)	0(000)
1(011)	0(000)	0(000)	0(000)	0(000)	0(000)	0(000)	0(000)	0(000)	0(000)	0(000)	0(000)	0(000)	0(000)
1(012)	0(000)	0(000)	0(000)	0(000)	0(000)	0(000)	0(000)	0(000)	0(000)	0(000)	0(000)	0(000)	0(000)
1(013)	0(000)	0(000)	0(000)	0(000)	0(000)	0(000)	0(000)	0(000)	0(000)	0(000)	0(000)	0(000)	0(000)
1(014)	0(000)	0(000)	0(000)	0(000)	0(000)	0(000)	0(000)	0(000)	0(000)	0(000)	0(000)	0(000)	0(000)
1(015)	0(000)	0(000)	0(000)	0(000)	0(000)	0(000)	0(000)	0(000)	0(000)	0(000)	0(000)	0(000)	0(000)
1(016)	0(000)	0(000)	0(000)	0(000)	0(000)	0(000)	0(000)	0(000)	0(000)	0(000)	0(000)	0(000)	0(000)
1(017)	0(000)	0(000)	0(000)	0(000)	0(000)	0(000)	0(000)	0(000)	0(000)	0(000)	0(000)	0(000)	0(000)
1(018)	0(000)	0(000)	0(000)	0(000)	0(000)	0(000)	0(000)	0(000)	0(000)	0(000)	0(000)	0(000)	0(000)
1(019)	0(000)	0(000)	0(000)	0(000)	0(000)	0(000)	0(000)	0(000)	0(000)	0(000)	0(000)	0(000)	0(000)
1(020)	0(000)	0(000)	0(000)	0(000)	0(000)	0(000)	0(000)	0(000)	0(000)	0(000)	0(000)	0(000)	0(000)

FIGURE 8  
INTEGRATION DECISION LOGIC

R(1) = 500-7800 I/F/M/N. 41MB. R(2) = 2800-6000 I/F/M/N. 41MB. R(3) = 2800-8000 I/F/M/N. 41MB.

NADC-75056-60

APPENDIX B

NAVAL AIR DEVELOPMENT CENTER  
WARMINSTER, PENNSYLVANIA 18974

6071  
18 Jun 1974

NAVAIRDEVCEEN REQUIREMENTS  
FOR AVOID II COLLISION  
AVOIDANCE EQUIPMENT

SECTION 1.0	References
SECTION 2.0	AVOID II Specification
SECTION 3.0	Deliverables

NOTE: IF THERE IS ANY CONFLICT BETWEEN ANY PART OF THIS DOCUMENT  
AND REFERENCE 1.1 UNDER SECTION 1.0 OF THIS DOCUMENT, THIS  
DOCUMENT SHALL GOVERN.

NADC-75056-60

SECTION 1.0  
REFERENCES

- 1.1 Honeywell Proposal E7417-RD of 31 May 1974 consisting of:
  - (1) Technical Description AVOID II, E7417-RD of 31 May 1974
  - (2) Letter 1PLC4-05-041 of 31 May 1974 - Price, Terms and Conditions
  - (3) Contract Pricing Proposal DD-633-4 of 31 May 1974
- 1.2 NAVAIRDEVCEM RFP N62269-74-R-0674 of 18 April 1974
- 1.3 MIL-STD-810B - Environmental Test Methods
- 1.4 NAVAIRDEVCEM Contract N62269-73-C-0487 of 22 January 1973 with Honeywell for delivery of AVOID I full collision avoidance systems with ancillary equipment.

NADC-75056-60

SECTION 2.0  
AVOID II SPECIFICATION

- 2.1 General: All of the following specifications are in addition to those contained in reference 1.1.
- 2.2 Power Output:  $\geq 54$  dBm
- 2.3 Receiver Sensitivity:  $< -68$  dBm for .99 probability\* of receiving correct altitude boundary, range and range rate with 1000 interrogations per second (20% of which are at the altitude setting of the AVOID II and traffic simulator) and 32,000 responses per second injected at the front end at a level of  $-64$  dBm. The 1000 (20/32,000/ $-64$  dBm combination will be referred to throughout this specification as SFL (Standard Fruit Level) and represents a level in excess of worst case conditions in the MITRE 1982 traffic model as established by Honeywell simulations. \*This allows for missed alarms not false alarms (see paragraph 2.8).
- 2.4 Dynamic Range: The performance of paragraph 2.3 shall be met over a dynamic range of 46 dB from  $-68$  dBm to  $-22$  dBm.
- 2.5 Accuracy: The following accuracies shall be obtained with SFL injected with an AVOID II connected to the traffic simulator at target signal levels of  $-8$  dBm and  $-22$  dBm and with an AVOID II connected to an AVOID II at the same levels.
- 2.5.1 Altitude Boundaries: When the difference between the digitized outputs of own altimeter and intruder altimeter (D) are equal to or less than the appropriate boundary, the TLS (threat level status) shall so indicate, e.g., if D is between 0 and 600 feet inclusive, TLS will be co-altitude; if D is between 700 feet and 1300 feet inclusive, TLS will be  $< 1300$  feet; if D is 1400 feet or more, there will be no TLS.
- 2.5.2 Range: Mean  $< 300$  feet  
Standard Deviation  $< 300$  feet
- 2.5.3 Range Rate: Mean  $< 10$  knots  
Standard Deviation  $< 30$  knots

- 2.6 Alarm Display Consistency: For all range rates from -48 knots to +550 knots with SFL injected and over the dynamic range of paragraph 2.4, once the TAU 2 threshold has been crossed (assuming the commands are not obeyed) the correct TAU 2 and TAU 1 alarms will be displayed with a probability of .99\* updated every 4 seconds from the range corresponding to the initial TAU 2 threshold crossing to 0.42 nautical mile opening. Accuracies to be consistent with paragraph 2.5. \*This allows for missed alarms not false alarms (see paragraph 2.8).
- 2.7 Update Time: Cycle time to completely process all targets within +1300 feet of own altitude and update the CAS display: < 4 seconds.
- 2.8 False Alarms: A displayed alarm will be considered false if it is extraneous or incorrect (other than a missed alarm). Extraneous alarms are those not associated, in range, with real targets but are the result of additional threatening tracks being formed by the interaction of fruit, threatening and non-threatening targets. Incorrect alarms are those associated in range with real targets being tracked in which the wrong alarm (a missed alarm is not considered wrong in the set of definitions used in this document) is displayed. Missed alarms are those associated in range with real targets being tracked in which no alarm is displayed even though the situation demands it (consistent with paragraph 2.5). Poor signal strength, or transponder blockage in the interrogate or response modes which inhibits replying to an interrogation, are the causes for missed alarms.
- 2.8.1 False Alarm Rate with SFL Only:  
 TAU 2 and advisories - < 10 alarms in 10,000 hours  
 TAU 1 - < 1 alarm in 10,000 hours
- 2.8.2 False Alarm Rate with SFL and Non-Threatening Targets (early or late alarms due to errors within the limits of paragraph 2.5 are not considered false alarms):  
 TAU 2 and advisories - < 10 alarms per 10,000 hours  
 TAU 1 - < 1 alarm per 10,000 hours
- 2.8.3 False Alarm Rate with SFL and Threatening Targets (early or late alarms due to errors within the limits of paragraph 2.5 are not considered false alarms):  
 TAU 2 and advisories - < 10 alarms per 10,000 hours  
 TAU 1 - < 1 alarm per 10,000 hours

NADC-75056-60

- 2.9 Vibration: Reference 1.3, curve B (2g), figure 514.1 two 15 minute cyclic scans of the frequency amplitude curve. Direction of the vibration through the vertical axis of the device mounted on CFF rack with isolators. Devices shall operate properly during and after vibration.
- 2.10 Temperature: 10°F to +135°F - Within 5 minutes after application of power devices shall operate without degradation over this ambient temperature range. For cooling, the device will draw air through openings in the rear across the IC boards, power supply and receiver/transmitter and exhaust through the front of the device.
- 2.11 Failure Rate: Prior to delivery and acceptance tests, the contractor shall be responsible for debugging and operating the equipment a sufficient number of hours to eliminate the early failures. During acceptance tests by NAVAIRDEVGEN, the equipment shall not experience greater than two failures in 80 hours of testing. To be considered flight worthy for purposes of evaluation, the equipment shall have a minimum MTBF of 50 hours.
- 2.12 Size and Weight:  $\leq 3/8$  SHORT ATR  
 $\leq 15$  pounds
- 2.13 Digital Outputs Connector: Digital outputs connector which interfaces with the DDI (Digital Display Interface) delivered under reference 1.4 shall be the same type of connector (indexing can differ) utilized on the DDI.
- 2.14 Co-Range Targets: Under all the conditions of paragraphs 2.3, 2.4 and 2.5, two targets which are separated by 350 feet or greater in range shall be correctly tracked and processed by the threat logic regardless of the altitude separation between the targets.
- 2.15 Remitter Mode: Device shall be capable of this mode by means of a one- or two-wire change on one of the PC boards.
- 2.16 CAS Display Compatibility: Two connectors shall be provided on the AVOID II; one will drive the existing CAS/VSI, display, the other will drive the new AVOID II CAS display with range marker lights.

SECTION 3.0  
DELIVERABLES

- 3.1 **General:** All of the following deliverables (except in cases where items are repeated) are in addition to those contained in references 1.1 and 1.2. In the case of the data items, the additional requirements of this section shall be combined with those in reference 1.2.
- 3.2 Following equipments delivered under reference 1.4 shall be modified by Honeywell to be completely compatible with the new AVOID II equipment:

<u>QUANTITY</u>	<u>DESCRIPTION</u>
3	AVOID I DDI (Digital Display and Interface)
3	AVOID I TS (Traffic Simulator)
3	AVOID I CAS (Collision Avoidance Systems)

- 3.3 **DDI Modifications**
- 3.3.1 **Dual Mode:** AVOID I or AVOID II mode accomplished automatically when either CAS is connected to the DDI.
- 3.3.2 **Three Aircraft Encounter Logic Dual Mode:** By means of a front panel switch, the modes shall be as follows:
- Position No. 1 - Existing logic in which only one intruder per altitude threat band is displayed and recorded up to a maximum of two.
- Position No. 2 - Modified logic in which the first two intruders whether they are in the same altitude threat band or in separate altitude threat bands are recorded. Intruder No. 1 or No. 2 will be displayed depending on the intruder selector switch position.
- 3.3.3 **Simulated Target Altitude:** DDI shall be modified to record on tape the altitudes set into the traffic simulator for each of two target sets. The algorithm to convert switch positions to altitude separation shall be furnished.
- 3.3.4 **Synchronous Reply Count:** Synchronous reply count received by the AVOID CAS from the TS shall be recorded. A mode switch shall permit display of fruit replies or synchronous replies.

NADC-75056-60

- 3.4 TS (Traffic Simulator) Modifications
- 3.4.1 Target Altitude Control: Each of two target sets will be provided with separate altitude band and bias switches.
- 3.4.2 Target Altitude Digital Outputs: TS shall be modified to provide digital altitude outputs for two target altitudes to enable them to be recorded on tape via the DDI.
- 3.4.3 Variable Range Control: Variable vernier range controls shall be provided for each of two target sets which will permit at any coarse range setting, an additional 0 to 500 feet (50 feet steps) to be set in.
- 3.4.4 Range Rate Extension: TS shall provide above 10,000-foot altitude a range rate output of 2000 fps + 5%, -0%, in lieu of the 1600 fps setting.
- 3.4.5 Separate Level Controls: Traffic simulators shall be modified so that each of the output levels of fruit replies, random interrogations and target replies can be independently controlled in steps of 0, 6, or 12 dB. In addition, target replies will be brought out on separate jacks for use with external attenuators.
- 3.4.6 Interrogations Received: Shall be modified to reflect the following output settings.

EXISTING PPS	TO BE MODIFIED TO THIS PPS
1536	2000
768	1000
384	500
192	250
96	125
48	63
24	31
12	15
6	7
0	0

3.4.7 Moving Targets Automatic Reset: In the moving targets mode, a target will be set in motion by placing the hold switch in the off position and pushing the reset button. The targets will then continue to the end of their range at which time the TS will automatically reset and start the targets moving again. The cycle will be repeated as long as the hold switch is in the off position; the cycle will cease when the hold switch is placed in the hold position. The TS shall inhibit the DDI from the time the targets have reached the end of their range until the time reset has been completed, the targets begin to move again and the TS is sending valid replies to the AVOID CAS. On inward bound targets, when the first target of the set has reached zero range, reset shall be initiated. On outward bound targets, when the last target of the set has reached maximum range, reset shall be initiated.

3.4.8 Random Synchronous Reply Mode: The purpose of this modification is to inject random replies (simulating targets) into the front end of the AVOID receiver during the AVOID listening period following an interrogation. In this mode, when the TS receives the first pulse pair (500 ns separation) of an interrogation it will, after appropriate delay, inject random pulses into the AVOID receiver during its listening period to cause bin densities in accordance with figure 3.4.8.

The number of random synchronous replies shall be selectable by a front panel switch (SW1): Position No. 1 - off; positions No. 2 through 8 corresponding to curves No. 2 through 8, respectively (figure 3.4.8). A second switch (SW2) shall be provided which in the No. 1 position will inject a different random set of pulses into the receiver after each interrogation. In the No. 2 position, it will provide a random set of pulses whose interpulse relationships shall remain constant from the beginning of a 4-second sequence (3 seconds for AVOID I) to the end of the second such sequence: the random set of pulses will change then each 8-second period (6 seconds for AVOID I). A separate level control shall be provided which will permit 0, 6, or 12 dB above the main attenuator setting on the TS. The listening period length shall be set to the correct value, automatically, as a function of altitude and CAS type: e.g., AVOID I or AVOID II. In positions No. 1 and 2 of SW2, the pattern of any random pulse set shall not be repeated in less than 10 hours of operation. Note: These synchronous random replies are in addition to the asynchronous random replies presently injected into the receiver over the entire sequence interval.

NADC-75056-60

- 3.5 Electrical Interconnecting Cables
  - 3.5.1 AVOID II - Five complete sets.
  - 3.5.2 DDI to TS for modification described in 3.3.3 and 3.4.2 - Six complete sets.
- 3.6 AVOID II CAS Cockpit Indicators
  - Quantity: Three
- 3.7 AVOID II Rack and Shock Mount
  - Quantity: Three
- 3.8 Data Items: Reference 1.4 applies to A001 through A008 inclusive, except as modified herein.
  - 3.8.1 A001 - Engineering drawings and associated data including electrical and mounting interface sketches for use during equipment installation and a complete set of schematics, logic diagrams and timing diagrams.
  - 3.8.2 A002 - Operating instructions shall include a complete, detailed, accurate and thorough theory of operation, complete with timing and logic diagrams, pertinent mathematical equations, tables and charts together with associated descriptive material. All pages shall be legible and clearly reproduced.
  - 3.8.3 A003 - Frequency Allocation Data (DD Form 1494).
  - 3.8.4 A004 - Spectrum Signature Data - MIL-D-18300.
  - 3.8.5 A005 - Equipment test procedures shall include all specification items in sections 2.0 and 3.0 of this document together with other tests to insure the operational integrity of the equipment to perform the collision avoidance function.
  - 3.8.6 A006 - Progress Reports - Shall be furnished bi-monthly instead of monthly as stated in reference 1.2.
  - 3.8.7 A007 - Final Report.
  - 3.8.8 A008 - Spectrum Signature Test Plan (MIL-D-18300).

- 3.8.9 A009 - Cost Estimate Data: Selling cost estimates of the AVOID II in quantities of 500, 1000, 3000, 10,000 and 25,000 (the latter three quantities being figured over a five-year production period) shall be furnished. Cost shall include the display but not the cost of an altimeter and altimeter encoder. Estimates should be based on a parts count exactly the way the units are built in one column together with a second column showing LSI units and other subassemblies which would replace those items in the first column on a function to function basis. LSI technology as of the date of the estimate shall be the reference. Specify what method of distribution of the product is contemplated together with the mark-up above the factory selling price.

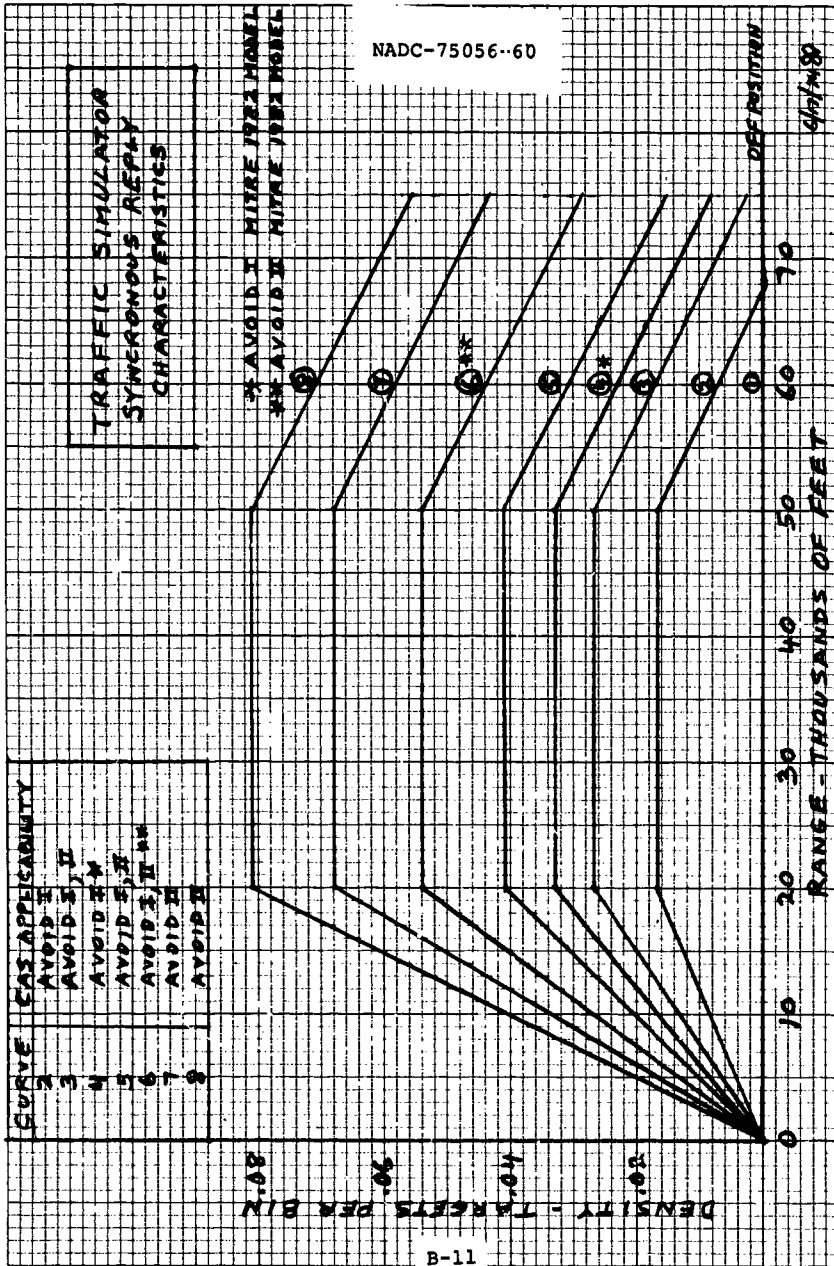

FIGURE 3.4.8-TARGET BIN DENSITY VS. RANGE

NADC-75056-60

APPENDIX C

Honeywell Customer Engineering Letter  
NADC-74-2 of October 4, 1974  
Post Shipment Modifications of the AVOID I



GOVERNMENT & AERONAUTICAL  
PRODUCTS DIVISION  
MINNEAPOLIS OPERATIONS

NADC-75056-60

C.E.L. NO. NADC-74-2

DATE October 4, 1974

PAGE 1 OF 3

## CUSTOMER ENGINEERING LETTER

U.S. Naval Air Development Center  
Johnsville  
Warminster, Pennsylvania 18974

Subject: POST SHIPMENT MODIFICATIONS OF THE AVOID-I

### SUMMARY

Four (4) modifications to the AVOID-I CAS have been made since delivery of the systems. The modifications and purpose for the modifications are:

The Tau filter altitude correlation was changed to the "expanded mode" for all altitudes. The original system used the expanded mode only for altitudes of 9,600 feet or above. This change was incorporated to insure that altitude correlation was obtained between the 600 and 1300 foot altitude bands for all allowable range rates. Prior to this change targets with a range rate of 800 feet/sec in the P5 or M5 bands could generate an incorrect coaltitude command.

The pulse pair codes were changed from 400 and 500 nanoseconds to 500 and 600 nanoseconds for pulse pair 1 and pulse pair 2 respectively. It was determined that for aircraft in close proximity IF saturation stretched pulse pair 1 to single pulse. The single pulse was not being decoded as pulse pair 1 and therefore no response was made. By changing the pulse codes to 500 and 600 nanoseconds all pulse pairs are decoded over a greater received signal level allowing proper system operation for two aircraft in close proximity.

An inhibit circuit was inserted in the video 1 and video 2 lines on card A6 such that only the first video signal received was gated to the remaining circuits. It was determined that, at signal strengths greater than 30db above the IF threshold, cross talk in the IF gave outputs on both channels with the opposite channel signal delayed from the direct signal resulting in two pulse pairs being received in place of the single pulse pair transmitted. A delayed pulse pair 2 when being compared with the direct pulse pair 1 resulted in false altitude decoding. By inhibiting the delayed signals the correct altitude is decoded.

An altitude acceptance gate inhibit circuit was incorporated such that if a pulse pair 2 is received in the 5 microsecond period prior to the altitude acceptance gate the altitude acceptance gate is inhibited. The inhibit was incorporated after it had been determined by flight tests that a pulse pair 2 from multipath coupled with a direct path pulse pair 1 would generate a response for interrogations that were below the altitude acceptance gate. The interrogating aircraft would thus see two intruders, the correct intruder and a multipath generated intruder which was at a farther range and below the actual intruder. The inhibit circuit removes this multipath generated intruder.

BACKGROUND

Tau Filter Altitude Correlation - Flight and bench tests indicated that at altitudes below 9,600 feet an intruder in the P5 and M5 bands, when inbound at 800 feet/sec would generate an occasional coaltitude Tau 1 or Tau 2 command. Bench test determined that with bin splitting, the multiple intruders could have one intruder which did not correlate in altitude. At 9,600 feet and above the wider correlation range resulted in altitude correlation with all intruders. The Tau filter altitude correlation width was thus changed such that the wider correlation range is used at all altitudes. The change was made by removing the line on card A3 pin 54 and connecting this line to +12 volts.

Pulse Pair Codes - Flight tests had indicated that pulse pair 1 was not correctly decoded at all times. Bench tests then determined that at strong signal levels the IF was stretching pulses such that pulse pair 1 was merged into a single pulse. The single pulse was not decoded as a pulse pair and the interrogated device thus did not respond. This resulted in a loss of communication when two aircraft were in close proximity. To insure that at all signal levels possible in flight, both pulse pairs are properly decoded the pulse pair spacing was changed from 400 and 500 nanoseconds to 500 and 600 nanoseconds for pulse pair 1 and pulse pair 2 respectively. To accomplish this the pulse pair encoding was changed by potentiometer adjustments in the transmitter module, the 500 nanosecond pulse pair decoders were connected to the pulse pair 1 outputs, and the 400 nanosecond pulse pair decoders were recalibrated to 600 nanoseconds and connected to the pulse pair 2 outputs. Recalibration of the 400 nanosecond pulse pair decoders was accomplished by changing the timing resistors for A4U63 and A4U78.

Video Inhibits - Flight tests indicated that at strong signal levels incorrect altitude correlation was obtained. This was confirmed by bench test which indicated that cross-talk in the IF was generating delayed pulses at strong signal levels. A single interrogation would thus generate four pulse pairs, a pulse pair 1 in the direct channel followed by a pulse pair 1 in the opposite channel and a pulse pair 2 in the direct channel followed by a pulse pair 2 in the opposite channel. The time between the direct channel pulse pair 1 and the opposite channel pulse pair 2 would indicate the interrogated altitude band was 100 feet higher than actually interrogated. To prevent this, the inhibit circuit shown as Figure 1 was inserted in the video 1 and video 2 lines. The circuit operates as follows:

The output of one shot U73 pin 6 is routed directly to U2 pin 9 and by 2 inverters to U2 pin 10. This removes any narrow low voltage pulses. The video signal is then routed to U12 pin 3 and to the toggle (pin 2) of U10-1. If the D input of U10-1 (pin 2) is high pins 4 and 5 of U12 are toggled high by U10-1, passing the pulse through U12 to the video 1 output. At this time, since U10-1 pin 5 is high, U10-1 pin 6 is low blocking the video 2 output. The video output pulse from U10 pin 6 triggers the one-shot U3-1 which clears U10-1 after a 160 nanosecond delay. This reenables the video 2 output.

Altitude Acceptance Gate Inhibit - Analysis of flight test data showed that due to multipath a single intruder could generate two commands. The incorrect command was generated when an interrogation was made, which had a pulse pair 2 occurring just prior to the altitude acceptance gate a delayed (multipath) pulse pair 2 could fall in the altitude acceptance gate and thus generate a

NADC-75056-60

response when the actual altitude interrogated would not generate a response. To correct this the circuit shown in figure 2 was inserted in the altitude gate. The circuit operates as follows:

The D input of a Flip Flop is connected to the Channel 1 response mode signal (A4 U16-5). This Flip Flop is clocked high 5 microseconds prior to the altitude acceptance gate which enables the altitude gate through the 7408 AND gate. The first pulse pair 2 received after the Flip Flop is clocked high then clears the Flip Flop. If this pulse occurs prior to the altitude acceptance gate, the gate is blocked by the 7408.

RG/pa

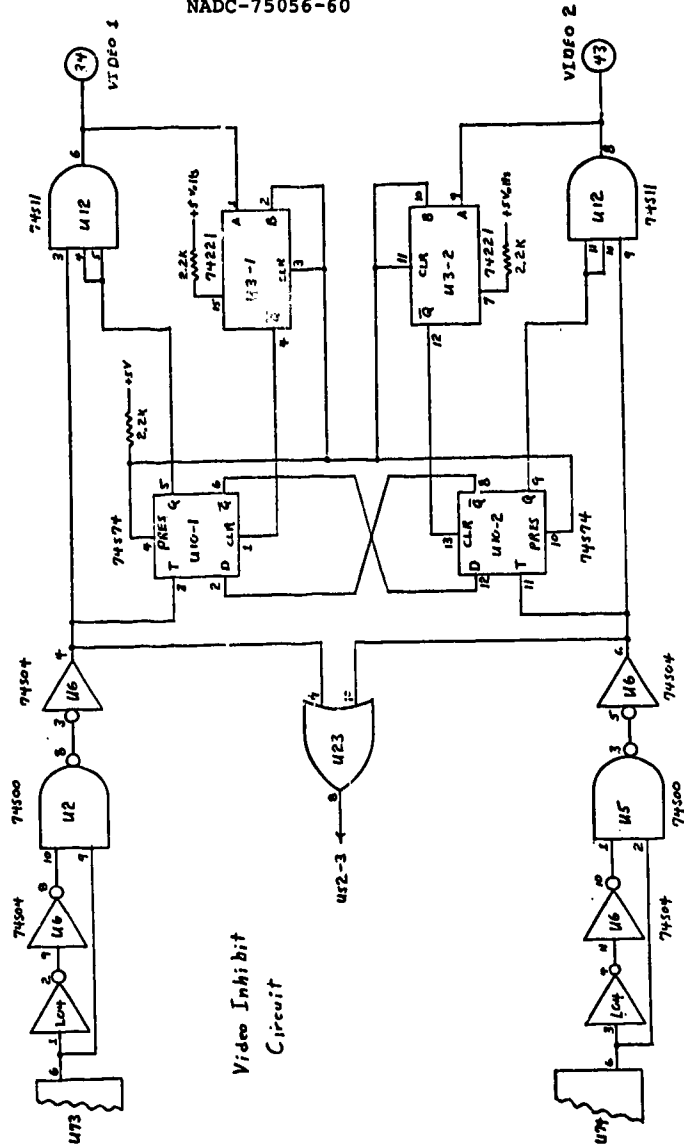

Video Inhibit  
Circuit

Figure 1

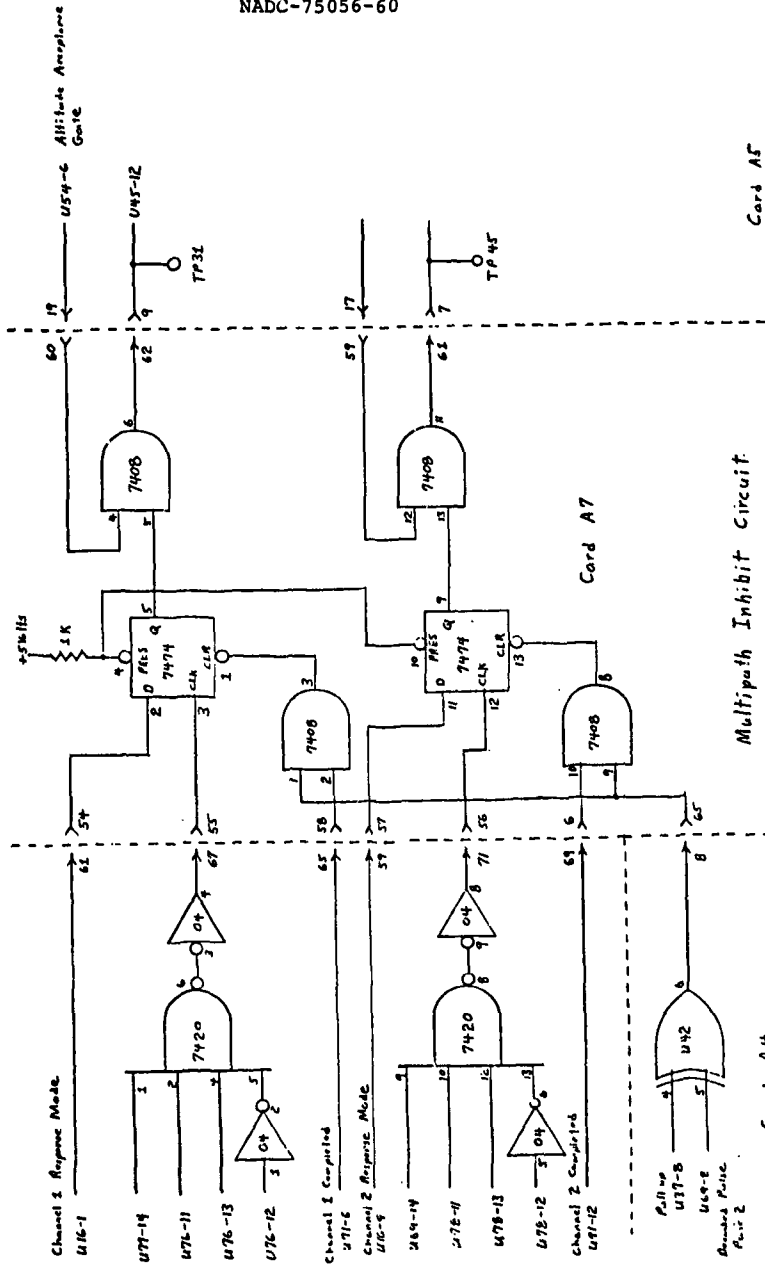

Multipath Inhibit Circuit.  
Figure 2

Card A7

Card A4

A

AIRCRAFT= NC-117 PRINTOUT OF RANGE AND RANGE RATE T  
 FLIGHT NO. 8  
 ENCOUNTER NO. 8

TIME			*****RANGE*****			*****RAN	
H	M	SEC	A/C (NMI)	THEOD (NMI)	DIFF (NMI)	A/C (KNTS)	TH (KN)
13	24	41.903	4.4090	4.3600	0.1490	82.000	74
13	24	45.049	4.4440	4.2997	0.1443	71.000	69
13	24	48.215	4.4780	4.2377	0.1403	82.000	70
13	25	1.371	4.4120	4.1763	0.1357	71.000	69
13	25	4.507	4.4260	4.1147	0.1313	82.000	71
13	25	7.717	4.4100	4.0514	0.1286	77.000	68
13	25	10.873	4.4110	3.9910	0.1400	71.000	70
13	25	14.009	4.4450	3.9293	0.1357	71.000	70
13	25	17.185	3.9990	3.8684	0.1306	71.000	69
13	25	20.331	3.9130	3.8079	0.1251	71.000	68
13	25	23.497	3.8880	3.7462	0.1218	71.000	71
13	25	26.653	3.8020	3.6854	0.1166	82.000	69
13	25	29.789	3.7520	3.6235	0.1285	71.000	70
13	25	32.965	3.6870	3.5602	0.1268	71.000	72
13	25	36.011	3.6210	3.4982	0.1228	77.000	73
13	25	39.288	3.5550	3.4312	0.1238	82.000	73
13	25	42.464	3.4730	3.3659	0.1071	82.000	72
13	25	45.510	3.4070	3.3048	0.1022	82.000	72
13	25	48.756	3.3570	3.2388	0.1182	71.000	72
13	25	51.932	3.2920	3.1749	0.1171	71.000	72
13	25	55.068	3.2260	3.1125	0.1135	71.000	71
13	25	58.244	3.1600	3.0487	0.1113	71.000	71
13	26	1.390	3.0940	2.9872	0.1068	82.000	70
13	26	4.538	3.0280	2.9251	0.1029	77.000	70
13	26	7.713	2.9620	2.8642	0.0978	71.000	69
13	26	10.890	2.8970	2.8026	0.0944	71.000	69
13	26	14.036	2.8310	2.7417	0.0893	82.000	70
13	24	17.212	2.7610	2.6797	0.1013	71.000	69
13	26	20.348	2.7160	2.6182	0.0978	71.000	70
13	26	22.524	2.6500	2.5764	0.0736	71.000	68
13	26	26.670	2.5840	2.4996	0.0844	71.000	65
13	26	29.816	2.5180	2.4398	0.0782	71.000	70
13	26	32.992	2.4690	2.3767	0.0923	71.000	69
13	26	36.172	2.4030	2.3188	0.0842	82.000	63
13	26	39.318	2.3370	2.2607	0.0763	71.000	71
13	26	42.494	2.2710	2.1953	0.0757	82.000	71
13	26	45.630	2.2220	2.1368	0.0852	71.000	65
13	26	48.806	2.1560	2.0792	0.0768	71.000	66
13	26	51.952	2.0900	2.0202	0.0698	71.000	64
13	26	55.098	2.0210	1.9631	0.0779	71.000	70

## APPENDIX D

OUT OF RANGE AND RANGE RATE TO P3A

***** DIFF (NMI)	*****RANGE RATE*****			*****TAU*****		
	A/C (KNTS)	THEOD (KNTS)	DIFF (KNTS)	A/C (SEC)	THEOD (SEC)	DIFF (SEC)
0.1490	82.000	74.038	7.962	197.96	212.00	-14.04
0.1443	71.000	69.495	1.505	225.33	222.73	2.60
0.1403	82.000	70.686	11.314	192.20	215.82	-23.62
0.1357	71.000	69.386	1.614	218.64	216.68	1.95
0.1313	82.000	71.752	10.248	186.41	206.45	-20.04
0.1286	77.000	68.741	8.259	195.43	212.17	-16.74
0.1400	71.000	70.321	0.679	209.46	204.31	5.14
0.1357	71.000	70.667	0.333	206.11	200.17	5.94
0.1306	71.000	69.801	1.199	202.77	199.51	3.25
0.1251	71.000	68.200	2.800	199.42	201.01	-1.59
0.1218	71.000	71.098	-0.098	196.12	189.68	6.44
0.1166	82.000	69.867	12.133	166.92	189.00	-22.98
0.1285	71.000	70.755	0.245	190.24	184.36	5.88
0.1268	71.000	72.933	-1.933	186.95	175.73	11.21
0.1228	77.000	73.516	3.484	169.29	171.30	-2.01
0.1238	82.000	73.779	8.221	156.07	167.42	-11.35
0.1071	82.000	72.973	9.027	152.47	166.05	-13.58
0.1022	82.000	72.897	9.103	149.58	163.21	-13.63
0.1182	71.000	72.504	-1.504	170.21	160.81	9.40
0.1171	71.000	72.756	-1.756	166.92	157.10	9.82
0.1135	71.000	71.017	-0.017	163.57	157.78	5.79
0.1113	71.000	71.398	-0.398	160.23	153.72	6.51
0.1068	82.000	70.571	11.429	135.83	152.39	-16.55
0.1029	77.000	70.115	6.885	141.57	150.19	-8.62
0.0978	71.000	69.380	1.620	150.19	148.62	1.57
0.0944	71.000	69.808	1.192	146.89	144.53	2.36
0.0893	82.000	70.038	11.962	124.29	140.93	-16.64
0.1013	71.000	69.763	1.237	141.01	138.26	2.73
0.0978	71.000	70.609	0.391	137.71	133.49	4.22
0.0736	71.000	68.830	2.170	134.37	134.75	-0.39
0.0844	71.000	65.773	5.227	131.02	136.81	-5.79
0.0782	71.000	70.905	0.095	127.67	123.87	3.80
0.0923	71.000	69.512	1.488	125.19	123.09	2.10
0.0842	82.000	63.473	18.527	105.50	131.52	-26.02
0.0763	71.000	71.139	-0.339	118.50	114.08	4.41
0.0757	82.000	71.536	10.464	99.70	110.48	-10.77
0.0852	71.000	65.929	5.071	112.66	116.68	-4.01
0.0768	71.000	66.268	4.732	109.32	112.95	-3.63
0.0698	71.000	64.951	6.049	105.97	111.97	-6.00
0.0779	71.000	70.664	0.336	103.49	100.01	3.48

TAU2 →

W/O WITH FRUIT

AIRCRAFT= NC-117 PRINTOUT OF RANGE AND RANGE RATE TO P3A  
FLIGHT NO. 8  
ENCOUNTER NO. 5

\*\*\*\*\*RANGE\*\*\*\*\*

POINTS 40  
MEAN= 0.1084 NM 658.55 FT  
RMS= 0.1107 NM 672.62 FT  
SIGMA= 0.0228 NM 138.63 FT

\*\*\*\*\*RANGE RATE\*\*\*\*\*

POINTS 40  
MEAN= 4.2739 KTS  
RMS= 6.4783 KTS  
SIGMA= 4.9305 KTS

7 PRINTOUT OF RANGE AND RANGE RATE TO P3A

8  
8

\*\*\*\*\*

\*\*\*\*\*RANGE RATE\*\*\*\*\*

\*\*\*\*\*TAU\*\*\*\*\*

.55 FT  
.62 FT  
.63 FT

POINTS 40  
MEAN= 4.2739 KTS  
RMS= 6.4783 KTS  
SIGMA= 4.9305 KTS

POINTS 40  
MEAN= -3.48 SECS  
RMS= 10.74 SECS  
SIGMA= 10.29 SECS

A

AIRCRAFT- P3A PRINTOUT OF RANGE AND RANGE RATE TO NC-117  
 FLIGHT NO. 8  
 ENCOUNTER NO. 6

TIME			*****RANGE*****			*****RANGE RATE*****		
H	M	SEC	A/c (NMI)	THEOD (NMI)	DIFF (NMI)	A/C (KNTS)	THEOD (KNTS)	DIFF (KNTS)
13	11	49.612	4.4420	4.3798	0.1622	159.000	150.064	8.936
13	11	52.834	4.4940	4.2459	0.1481	118.000	148.416	-30.416
13	11	56.055	4.5430	4.1119	0.1511	154.000	148.777	5.223
13	11	59.288	4.6140	3.9794	0.1346	165.000	147.720	17.280
13	12	2.519	3.9430	3.8468	0.1362	159.000	147.573	11.427
13	12	5.740	3.8410	3.7155	0.1355	159.000	147.084	11.916
13	12	9.002	3.7030	3.5808	0.1222	159.000	147.491	11.509
13	12	12.225	3.4710	3.4501	0.1209	159.000	146.545	12.455
13	12	15.458	3.4400	3.3184	0.1216	159.000	146.514	12.436
13	12	18.689	3.4080	3.1863	0.1217	159.000	146.387	12.613
13	12	21.921	3.1760	3.0576	0.1184	148.000	142.197	5.803
13	12	25.395	2.9130	2.8008	0.1122	154.000	143.770	10.230
13	12	28.627	2.7450	2.6722	0.0928	159.000	143.605	15.395
13	12	31.858	2.4330	2.5421	0.0909	159.000	143.847	15.111
13	12	35.089	2.4020	2.4137	0.0883	148.000	145.476	2.614
13	12	38.344	2.3700	2.2819	0.0881	148.000	143.861	4.139
13	12	41.565	2.2380	2.1528	0.0852	159.000	144.430	14.535
13	12	44.807	2.1070	2.0243	0.0827	148.000	143.307	4.693
13	12	48.030	1.9750	1.8946	0.0804	154.000	146.229	7.771
13	12	51.261	1.8430	1.7641	0.0789	148.000	143.538	4.662
13	12	54.513	1.6950	1.6746	0.0204	159.000	143.006	15.994
13	13	0.714	1.4430	1.5065	0.0565	159.000	145.079	13.365
13	13	3.979	1.4120	1.3758	0.0362	159.000	145.771	13.842
13	13	7.100	1.3000	1.2476	0.0524	159.000	147.578	11.422
13	13	10.431	1.1490	1.1105	0.0585	159.000	149.049	9.951
13	13	13.683	1.0200	0.9784	0.0416	159.000	144.508	14.175
13	13	16.884	0.8490	0.8493	0.0397	148.000	145.022	2.962
13	13	20.107	0.7570	0.7210	0.0360	154.000	140.860	13.240
13	13	23.381	0.4250	0.5915	0.0335	148.000	141.839	6.161
13	13	26.600	0.4940	0.4679	0.0261	148.000	132.667	15.333
13	13	29.855	0.3790	0.3539	0.0251	136.000	120.881	15.119
13	13	33.025	0.4080	0.4086	0.0194	-130.000	-126.899	-3.101
13	13	36.227	0.4400	0.5227	0.0373	-142.000	-133.225	-8.225
13	13	39.448	0.4910	0.6436	0.0474	-154.000	-134.107	-19.893

NTOUT OF RANGE AND RANGE RATE TO NC-117

APPENDIX E

***** DIFF (NMI)	*****RANGE RATE***** A/C THEOD DIFF (KNTS) (KNTS) (KNTS)			*****TAU***** A/C THEOD DIFF (SEC) (SEC) (SEC)		
0.1622	159.000	150.064	8.936	102.84	105.07	-2.23
0.1481	118.000	148.416	-30.416	134.05	102.99	31.07
0.1511	154.000	148.777	5.223	99.65	99.50	0.16
0.1346	165.000	147.720	17.280	89.76	96.98	-7.22
0.1362	159.000	147.573	11.427	90.18	93.84	-3.66
0.1355	159.000	147.084	11.916	87.19	90.94	-3.75
0.1222	159.000	147.891	11.509	83.84	87.40	-3.56
0.1209	159.000	146.545	12.455	80.85	84.76	-3.90
0.1216	159.000	146.514	12.486	77.89	81.54	-3.65
0.1217	159.000	146.387	12.613	74.90	78.36	-3.46
0.1184	148.000	142.197	5.803	77.25	77.41	-0.15
0.1122	154.000	143.770	10.230	68.10	70.13	-2.04
0.0928	159.000	143.605	15.395	62.60	66.99	-4.38
0.0909	159.000	143.847	15.153	59.62	63.62	-4.00
0.0883	148.000	145.476	2.524	60.86	59.73	1.13
0.0881	148.000	143.861	4.139	57.65	57.10	0.55
0.0852	159.000	144.430	14.570	50.67	53.66	-2.99
0.0827	148.000	143.307	4.693	51.25	50.85	0.40
0.0804	154.000	146.229	7.771	46.17	46.64	-0.47
0.0789	148.000	143.538	4.462	44.83	44.25	0.58
0.0204	159.000	143.006	15.994	38.38	42.16	-3.78
0.0565	159.000	145.079	13.921	35.39	37.38	-1.99
0.0562	159.000	145.771	13.229	32.42	33.98	-1.56
0.0524	159.000	147.578	11.422	29.43	30.43	-1.00
0.0585	159.000	149.049	9.951	26.47	26.82	-0.35
0.0416	159.000	144.508	14.492	23.09	24.37	-1.28
0.0397	140.000	145.022	2.978	21.62	21.08	0.54
0.0360	154.000	140.860	13.140	17.70	18.43	-0.73
0.0335	148.000	141.839	6.161	15.20	15.01	0.19
0.0261	148.000	132.667	15.333	12.02	12.70	-0.68
0.0251	136.000	120.881	15.119	10.03	10.54	-0.51
0.0194	-130.000	-126.899	-3.101	-11.85	-11.59	-0.26
0.0373	-142.000	-133.225	-8.775	-14.20	-14.13	-0.07
0.0474	-154.000	-134.107	-19.893	-16.15	-17.28	1.12

TAU 2 →

TAU 1 →

A  
W/O WITH FRUIT

AIRCRAFT= P3A PRINTOUT OF RANGE AND RANGE RATE TO NC-117  
FLIGHT NO. 8  
ENCOUNTER NO. 6

\*\*\*\*\*RANGE\*\*\*\*\*

\*\*\*\*\*RANGE RATE\*\*\*\*\*

\*\*\*\*\*

POINTS 34  
MEAN= 0.0030 NM 504.38 FT  
RMS= 0.0012 NM 566.10 FT  
SIGMA= 0.0029 NM 260.90 FT

POINTS 34  
MEAN= 7.5924 KTS  
RMS= 12.5776 KTS  
SIGMA= 10.1783 KTS

PO  
ME  
RM  
SI

OF RANGE AND RANGE RATE TO NC-117

\*\*\*\*\*RANGE RATE\*\*\*\*\*

POINTS 34  
MEAN= 7.5924 KTS  
RMS= 12.5776 KTS  
SIGMA= 10.1763 KTS

\*\*\*\*\*TAU\*\*\*\*\*

POINTS 34  
MEAN= -0.65 SECS  
RMS= 5.89 SECS  
SIGMA= 5.94 SECS

A

AIRCRAFT<sup>0</sup> NC-117 PRINTOUT OF RANGE AND RANGE RATE TO P3A  
 FLIGHT NO. 8  
 ENCOUNTER NO. 2

TIME			*****RANGE*****			*****RANGE RATE**		
H	M	SEC	A/C (NMI)	THEOD (NMI)	DIFF (NMI)	A/C (KNTS)	THEOD (KNTS)	DIFF (KNTS)
12	43	27.549	9.9410	9.6289	0.3121	325.000	325.357	
12	43	30.755	9.6280	9.3407	0.2873	361.000	328.873	
12	43	33.911	9.3320	9.0533	0.2787	361.000	328.688	
12	43	37.047	9.0350	8.7657	0.2693	361.000	330.439	
12	43	40.223	8.7390	8.4737	0.2653	349.000	330.523	
12	43	43.359	8.4430	8.1867	0.2563	343.000	328.859	
12	43	46.535	8.1470	7.8966	0.2504	343.000	329.016	
12	43	49.691	7.8500	7.6086	0.2414	337.000	330.714	
12	43	52.827	7.5580	7.3191	0.2189	349.000	331.531	
12	43	56.003	7.2610	7.0251	0.2159	337.000	331.716	
12	43	59.139	6.9650	6.7390	0.2060	355.000	330.387	
12	44	2.315	6.6690	6.4464	0.2026	343.000	331.587	
12	44	5.418	6.3760	6.1577	0.1783	325.000	335.219	
12	44	8.987	5.9910	5.8262	0.1648	349.000	336.432	
12	44	15.278	5.3980	5.2403	0.1577	355.000	331.580	
12	44	18.454	5.1020	4.9471	0.1549	349.000	336.456	
12	44	21.590	4.8060	4.6549	0.1511	349.000	331.616	
12	44	24.766	4.4930	4.3631	0.1299	349.000	330.894	
12	44	27.812	4.1970	4.0835	0.1135	355.000	332.946	
12	44	31.058	3.9010	3.7817	0.1193	349.000	333.873	
12	44	34.234	3.6040	3.4888	0.1152	337.000	330.220	
12	44	37.370	3.2920	3.1998	0.0922	343.000	331.887	
12	44	40.546	2.9950	2.9080	0.0870	337.000	332.167	
12	44	43.692	2.6990	2.6186	0.0804	337.000	329.488	
12	44	46.838	2.4030	2.3300	0.0730	337.000	330.193	
12	44	50.014	2.1070	2.0409	0.0661	337.000	328.472	
12	44	53.148	1.8100	1.7551	0.0549	337.000	328.241	
12	44	56.324	1.5140	1.4662	0.0478	337.000	328.947	
12	44	59.470	1.2180	1.1815	0.0365	337.000	321.589	
12	45	2.616	0.9280	0.9017	0.0363	337.000	322.689	

## APPENDIX F

OUT OF RANGE AND RANGE RATE TO P3A

***** IFF (NMI)	***** A/C (KNTS)	***** RANGE RATE THEOD (KNTS)	***** DIFF (KNTS)	***** A/C (SEC)	***** TAU THEOD (SEC)	***** DIFF (SEC)
3121	325.000	325.357	-0.357	110.12	106.54	3.57
2873	361.000	328.873	32.127	96.01	102.25	-6.23
2787	361.000	328.688	32.312	93.06	99.16	-6.10
2693	361.000	330.439	30.561	90.10	95.50	-5.40
2653	349.000	330.523	18.477	90.14	92.29	-2.15
2563	343.000	328.859	14.141	88.61	89.62	-1.00
2504	343.000	329.016	13.984	85.51	86.40	-0.89
2414	337.000	330.714	6.286	83.86	82.82	1.03
2189	349.000	331.531	17.469	77.76	79.48	-1.72
2159	337.000	331.716	5.284	77.35	76.24	1.11
2060	355.000	330.387	24.613	70.43	73.43	-3.00
2026	343.000	331.587	11.413	69.79	69.99	-0.20
1783	325.000	335.219	-10.219	70.18	66.13	4.05
1648	349.000	336.432	12.568	61.80	62.34	-0.55
1577	355.000	331.580	23.420	54.74	56.89	-2.15
1549	349.000	336.456	12.544	52.63	52.93	-0.31
1511	349.000	331.616	17.384	49.57	50.53	-0.96
1299	349.000	330.894	18.106	46.35	47.47	-1.12
1135	353.000	332.946	22.054	42.56	44.15	-1.59
1193	349.000	333.873	15.127	40.24	40.78	-0.54
1152	337.000	330.220	6.780	38.50	38.03	0.46
0922	343.000	331.887	11.113	34.55	34.71	-0.16
0870	337.000	332.167	4.833	31.99	31.52	0.48
0804	337.000	329.488	7.512	28.83	28.61	0.22
0730	337.000	330.193	6.807	25.67	25.40	0.27
0661	337.000	326.472	10.528	22.51	22.50	0.00
0549	337.000	328.841	8.159	19.34	19.21	0.12
0478	337.000	326.947	10.053	16.17	16.14	0.03
0365	337.000	321.589	15.411	13.01	13.23	-0.22
0363	337.000	322.689	14.311	10.02	10.06	-0.04

TAU 2 →

TAU 1 →

A

W/O WITH FRUIT

AIRCRAFT= NC-117 PRINTOUT OF RANGE AND RANGE RATE TO P3A  
FLIGHT NO. 8  
ENCOUNTER NO. 2

\*\*\*\*\*RANGE\*\*\*\*\*

\*\*\*\*\*RANGE RATE\*\*\*\*\*

POINTS 30  
MEAN= 0.1421 NM 922.92 FT  
RMS= 0.1220 NM 1105.60 FT  
SIGMA= 0.0241 NM 510.85 FT

POINTS 30  
MEAN= 13.7600 KTS  
RMS= 16.5184 KTS  
SIGMA= 9.2951 KTS

OF RANGE AND RANGE RATE TO P3A

\*\*\*\*\*RANGE RATE\*\*\*\*\*

POINTS 30  
MEAN= 13.7600 KTS  
RMS= 16.5184 KTS  
SIGMA= 9.2951 KTS

\*\*\*\*\*TAU\*\*\*\*\*

POINTS 30  
MEAN= -0.77 SECS  
RMS= 2.35 SECS  
SIGMA= 2.26 SECS



OUT OF RANGE AND RANGE RATE TO RA-3B

APPENDIX G

***** FF (MI)	*****RANGE RATE*****			*****TAU*****		
	A/C (KNTS)	THEOD (KNTS)	DIFF (KNTS)	A/C (SEC)	THEOD (SEC)	DIFF (SEC)
038	556.000	552.699	3.301	16.02	35.56	0.46
0951	568.000	554.961	13.039	32.13	32.27	-0.14
0854	562.000	552.509	9.491	29.31	29.25	0.05
587	574.000	551.578	22.422	25.49	26.15	-0.65
503	568.000	552.512	15.488	22.63	22.94	-0.31
532	562.000	550.575	11.425	19.82	19.88	-0.05
387	562.000	548.681	13.319	16.65	16.81	-0.15
241	562.000	544.543	17.457	13.50	13.77	-0.27
088	551.000	547.091	3.909	10.54	10.56	-0.02
024	556.000	537.361	18.639	7.36	7.59	-0.24

TAU1 →

A

W/O WITH FRUIT

AIRCRAFT# P3A PRINTOUT OF RANGE AND RANGE RATE TO RA-3B  
FLIGHT NO. 10  
ENCOUNTFR NO. 2

\*\*\*\*\*RANGE\*\*\*\*\*

\*\*\*\*\*RANGE RATE\*\*\*\*\*

POINTS 10  
MEAN= 0.0521 NM 316.38 FT  
RMS= 0.0617 NM 375.00 FT  
SIGMA= 0.0349 NM 212.21 FT

POINTS 10  
MEAN= 12.8489 KTS  
RMS= 14.1031 KTS  
SIGMA= 6.1285 KTS

PC  
ME  
RM  
SI

OUT OF RANGE AND RANGE RATE TO RA-38

\*\*\*\*\*RANGE RATE\*\*\*\*\*

POINTS 10  
MEAN= 12.8489 KTS  
RMS= 14.1031 KTS  
SIGMA= 6.1285 KTS

\*\*\*\*\*TAU\*\*\*\*\*

POINTS 10  
MEAN= -0.13 SECS  
RMS= 0.30 SECS  
SIGMA= 0.29 SECS

A

AIRCRAFT P3A PRINTOUT OF RANGE AND RANGE RATE TO RA-3B  
 FLIGHT NO. 18  
 ENCOUNTER NO. 10

TIME			*****RANGE*****			*****RANGE RATE****		
H	M	SEC	A/P (NMI)	THEOD (NMI)	DIFF (NMI)	A/C (KNTS)	THEOD (KNTS)	DIFF (KNTS)
14	1A	24.397	9.5620	9.3609	0.2011	847.000	835.474	11.526
14	1A	27.553	8.8050	8.6282	0.1768	817.000	837.754	-20.754
14	1A	33.833	7.2910	7.1616	0.1294	865.000	844.481	20.519
14	1A	36.969	6.5010	6.4236	0.0774	900.000	847.520	52.480
14	1A	40.145	5.7770	5.6738	0.1032	865.000	854.035	10.965
14	1A	43.280	5.0030	4.9293	0.0737	894.000	855.903	38.097
14	1A	46.322	4.2300	4.2048	0.0252	900.000	860.640	39.360
14	1A	49.558	3.4560	3.4290	0.0270	894.000	864.314	29.686
14	1A	52.735	2.6830	2.6648	0.0182	888.000	866.731	21.269
14	1A	55.882	1.9090	1.9077	0.0013	888.000	866.132	21.868

B

OUT OF RANGE AND RANGE RATE TO RA-38

APPENDIX H

***** IFF (NMI)	*****RANGE RATE*****			*****TAU*****		
	A/C (KNTS)	THEOD (KNTS)	DIFF (KNTS)	A/C (SEC)	THEOD (SEC)	DIFF (SEC)
0011	847.000	835.474	11.526	TAU2 → 40.64	40.34	0.31
0168	817.000	837.754	-20.754	38.80	37.08	1.72
0294	865.000	844.481	20.519	30.34	30.53	-0.19
0774	900.000	847.520	52.480	TAU1 → 26.00	27.29	-1.28
1032	865.000	854.035	10.965	24.04	23.92	0.13
0737	894.000	855.903	38.097	20.15	20.73	-0.59
0252	900.000	860.640	39.360	16.92	17.59	-0.67
0270	894.000	864.314	29.686	13.92	14.28	-0.37
0182	888.000	866.731	21.269	10.88	11.07	-0.19
0013	888.000	866.132	21.868	7.74	7.93	-0.19

A

W/O WITH FRUIT

AIRCRAFT= P3A PRINTOUT OF RANGE AND RANGE RATE TO RA-3B  
FLIGHT NO. 18  
ENCOUNTFR NO. 10

\*\*\*\*\*RANGE\*\*\*\*\*

POINTS 10  
MEAN= 0.0093 NM 506.37 FT  
RMS= 0.1049 NM 643.69 FT  
SIGMA= 0.0669 NM 418.90 FT

\*\*\*\*\*RANGE RATE\*\*\*\*\*

POINTS 10  
MEAN= 22.5015 KTS  
RMS= 29.4471 KTS  
SIGMA= 20.0226 KTS

OUT OF RANGE AND RANGE RATE TO RA-3B

\*\*\*\*\*RANGE RATE\*\*\*\*\*

POINTS 10  
MEAN= 22.5015 KTS  
RMS= 29.4471 KTS  
SIGMA= 20.0226 KTS

\*\*\*\*\*TAU\*\*\*\*\*

POINTS 10  
MEAN= -0.13 SECS  
RMS= 0.76 SECS  
SIGMA= 0.79 SECS

## APPENDIX I

TABLE I-1 RANGE-RANGE RATE  
ERROR STATISTICS

Data Sample N	Range Difference		Range Rate Difference Knots		Data Group
	Mean % of Range	Sigma Feet	Mean	Sigma	
1839	2.5	154	9.6	11.0	All Data w/wo Fruit
1418	2.7	132	8.6	10.2	" wo Fruit
421	2.1	197	13.1	12.9	" w Fruit
1642	2.5	164	10.9	10.6	All Closing w/wo Fruit
1258	2.7	138	9.8	9.8	" wo Fruit
383	2.1	206	14.6	12.3	" w Fruit
198	2.7	50	-1.0	8.4	All Opening w/wo Fruit
160	2.7	54	-0.8	8.4	" wo Fruit
38	2.9	27	-1.7	8.2	" w Fruit
28	4.7	219	22.0	12.6	Closing w/wo Fruit 10-9 nm.
33	0.5	209	19.5	14.5	" 9-8
43	3.6	179	14.6	11.3	" 8-7
52	3.3	238	18.9	13.4	" 7-6
76	1.7	210	16.2	11.3	" 6-5
148	3.1	196	15.8	12.5	" 5-4
285	2.2	190	10.2	9.5	" 4-3
444	2.8	149	8.5	9.0	" 3-2
459	2.9	126	8.6	8.9	" 2-1
74	1.6	87	11.3	10.0	" 1-0
52	2.2	40	-1.1	7.4	Opening w/wo Fruit 0-1
126	3.1	51	-5.1	8.9	" 1-2
17	0.2	53	-3.3	7.0	" 2-3
17	3.4	102	23.3	13.5	Closing wo Fruit 10-9
21	3.0	204	15.3	9.0	" 9-8
28	2.5	118	12.8	10.6	" 8-7
35	2.6	158	16.5	12.8	" 7-6
52	2.3	177	15.1	9.9	" 6-5
115	3.6	166	14.2	11.8	" 5-4
234	2.3	146	8.9	8.9	" 4-3
348	2.9	134	7.7	8.3	" 3-2
347	3.2	121	7.9	8.3	" 2-1
61	0.8	93	11.6	10.6	" 1-0
41	2.2	44	-2.2	7.3	Opening wo Fruit 0-1
103	3.1	55	0.5	9.0	" 1-2
13	0.7	58	-2.0	7.0	" 2-3

## APPENDIX I

TABLE I-1 RANGE-RANGE RATE  
ERROR STATISTICS (Cont.)

Data Sample N	Range Difference			Range Rate Difference			Data Group
	Mean % of Range	Sigma Feet		Knots			
				Mean	Sigma		
11	5.0	227		19.9	11.4		Closing w Fruit 10-9 nmi
12	-3.1	193		26.8	19.4		" 9-8
15	5.2	221		17.8	12.4		" 8-7
17	6.4	303		23.9	12.8		" 7-6
24	-0.8	250		18.6	13.8		" 6-5
33	1.8	245		21.6	13.6		" 5-4
50	-0.6	266		16.2	10.2		" 4-3
96	2.4	192		11.4	10.6		" 3-2
112	1.7	137		10.6	10.0		" 2-1
13	4.7	24		10.0	9.6		" 1-0
11	12.4	11		3.0	6.6		Opening w Fruit 0-1
23	3.3	24		-3.0	8.4		" 1-2
4	-1.7	33		-7.2	5.7		" 2-3

w-Data With Fruit  
wo-Data Without Fruit  
w/wo-All Data With And Without Fruit

## APPENDIX J

DISTRIBUTION OF THE MAXIMUM OF  
TWO SAMPLES FROM IDENTICAL NORMALS

1. An alternative derivation, here of the pdf, may help clarify the result. We have 2 identical normal distributions and pick one sample from each. The greater of the 2 (maximum) is chosen. What is the distribution of the sample chosen? Let the original normal assumed with zero mean and unit standard deviation, have pdf  $f(x)$  and cdf  $F(x)$ . Then

$$f(x) = \frac{1}{\sqrt{2\pi}} e^{-x^2/2}, \quad F(x) = \frac{1}{\sqrt{2\pi}} \int_{-\infty}^x e^{-t^2/2} dt \quad (1-1)$$

Now, in general, if we have 2 random variables  $X_1$  and  $X_2$  with corresponding distributions  $f_1$  and  $f_2$  (pdf) and  $F_1$  and  $F_2$  (cdf), pick one sample from each distribution and retain the greater, the following is true:

In order to retain a sample of value  $u$ , either of 2 mutually exclusive events occurs. Either  $X_1 = u$  and  $X_2 \leq X_1 = u$  or  $X_2 = u$  and  $X_1 < X_2 = u$ .

(The equality in  $X_2 \leq X_1$  is used in order to take care of ties and is used only there to keep the events mutually exclusive). Since the events are mutually exclusive, their probabilities are additive. Also, they are exhaustive (take care of all possibilities). Therefore, if the pdf of the greater of the 2 samples is called  $g(u)$  (the probability that a sample of value  $u$  is picked and retained) then

$$g(u) = f_1(u)F_2(u) + f_2(u)F_1(u) \quad (1-2)$$

( $f_1(u)$  is the probability that  $X_1 = u$  and  $F_2(u)$  is the probability that  $X_2 \leq u$ , etc. in accordance with the analysis above). In the case under consideration

$$\begin{aligned} f_1(u) &= f_2(u) = f(u) \\ F_1(u) &= F_2(u) = F(u) \end{aligned} \quad (1-3)$$

so that

$$g(u) = 2f(u)F(u) \quad (1-4)$$

The c.d.f.,  $G(u)$  is then

$$G(u) = [F(u)]^2 \quad (1-5)$$

since  $f(u) = dF(u)/du$ .

2. It turns out that it is possible to get the mean and variance of the distribution  $g(u)$  analytically using integration by parts. Let the mean be  $\mu_1$ . Then, by definition

$$\mu_1 = \int_{-\infty}^{\infty} tg(t)dt = 2 \int_{-\infty}^{\infty} tf(t)F(t) dt \quad (2-1)$$

with  $f(t)$ ,  $F(t)$  defined in (1-1). Also  $f(t) = dF(t)/dt$ . Then, integrating by parts, setting  $U = F(t)$ ;  $dV = tf(t)dt$ .

$$\text{Thus } dV = \frac{t}{\sqrt{2\pi}} e^{-t^2/2} dt \text{ and } V = -\frac{1}{\sqrt{2\pi}} e^{-t^2/2} = -f(t) \quad (2-2)$$

$$\text{Then } \mu_1 = 2 \left\{ \left[ -f(t)F(t) \right] - \int_{-\infty}^{\infty} [-f(t)]^2 dt \right\} \quad (2-3)$$

Now, the square bracketed term = 0 since  $f(-\infty) = 0$ ,  $f(\infty) = 0$ ,  $F(-\infty) = 0$ ,  $F(\infty) = 1$ . Also,

$$\left[ f(t) \right]^2 = \frac{1}{2\pi} \left( e^{-t^2/2} \right)^2 = \frac{1}{2\pi} e^{-t^2} \quad (2-4)$$

Then

$$\mu_1 = 2 \int_{-\infty}^{\infty} \left[ f(t) \right]^2 dt = \frac{1}{\pi} \int_{-\infty}^{\infty} e^{-t^2} dt = \frac{1}{\sqrt{\pi}} \quad (2-5)$$

$$\left( \int_{-\infty}^{\infty} e^{-t^2} dt = \sqrt{\pi}, \text{ available in tables, etc.} \right)$$

Thus, in general, the mean of  $g(u)$  is shifted  $\frac{\sigma}{\sqrt{\pi}}$  to the right of the normal mean. ( $\sigma$  applies to the original normal)  
 For the variance, the same technique is applied to obtain the non-central second moment  $m_2$ .

$$m_2 = 2 \int_{-\infty}^{\infty} t^2 f(t) \{ F(t) \} dt \quad (2-6)$$

Here

$$U = tF(t) \text{ and } dV = tf(t)dt; V = -f(t), \text{ as before.}$$

Then

$$m_2 = 2 \left\{ \int_{-\infty}^{\infty} [-f(t)tF(t)] - \int_{-\infty}^{\infty} -f(t) [tf(t) + F(t)] dt \right\} \quad (2-7)$$

Again, the square-bracketed term is zero (here  $f(t)$  goes to zero at  $-\infty$  and  $\infty$  faster than  $t$  goes to  $\infty$ ). Then

$$m_2 = 2 \int_{-\infty}^{\infty} t [f(t)]^2 dt + 2 \int_{-\infty}^{\infty} f(t)F(t) dt \quad (2-8)$$

Now,

$$2f(t)F(t) = g(t), \text{ and } \int_{-\infty}^{\infty} g(t) dt = G(\infty) = 1;$$

While

$$\begin{aligned} 2 \int_{-\infty}^{\infty} t [f(t)]^2 dt &= \frac{2}{2\pi} \int_{-\infty}^{\infty} te^{-t^2} dt \\ &= -\frac{1}{2\pi} \left[ e^{-t^2} \right]_{-\infty}^{\infty} = 0 \end{aligned} \quad (2-9)$$

Thus

$$m_2 = 1 \text{ and the variance, } \mu_2, \text{ is } \mu_2 = m_2 - \mu_1^2 = 1 - \frac{1}{\pi} \quad (2-10)$$

Then, in general, the variance is  $(1 - \frac{1}{\pi}) \sigma^2$

3. As a matter of interest, it may be shown that the distribution is skewed. All we need to show is that the mean and mode (point of maximum value of the distribution) are not the same. Equivalently, since the distribution is unimodal, we need only show that the slope of the distribution at the mean is non-zero. Thus,

$$\begin{aligned} g'(\mu_1) &= 2 \left[ f^2(\mu_1) - \mu_1 f(\mu_1) F(\mu_1) \right] \\ &= 2 f(\mu_1) \left[ f(\mu_1) - \mu_1 F(\mu_1) \right] \end{aligned} \quad (3-1)$$

Now,  $f(\mu_1) > 0$  and looking up values in the tables for  $f(\mu_1)$  and  $F(\mu_1)$  ( $\mu_1 = \frac{1}{\sqrt{\pi}}$ ) we find that  $g'(\mu_1) < 0$ . Therefore, the mode (peak) of the distribution occurs to the left of the mean.

A

FLIGHT NO. 9

ENCOUNTER NO. 24

DATE 7 17

TIME		DISPLAY	TARGET NO. 1			TARGET NO. 2			ALT	PLS	TX		
HR	MIN SEC		RANGE	RATE	TAU	THR 1	RANGE	PATF				TAU	THR 2
14	8	5.68	217.0	6290	34	0.0	-0	0	10.5	48.9	30		
14	8	20.04	225.4	4890	45	0.0	-0	0	10.5	49.4	30		
14	8	30.81	221.0	5100	47	0.0	-0	0	10.5	49.1	30		
14	8	34.42	117.7	650	90	0.0	-0	0	10.5	49.0	30		
14	8	41.58	99.2	620	90	0.0	-0	0	10.5	49.4	30		
14	8	59.54	251.4	4090	61	0.0	-0	0	10.5	49.0	30		
14	9	6.73	255.8	5190	49	0.0	-0	0	10.5	49.3	31		
14	9	13.92	156.4	7620	20	0.0	-0	0	10.5	49.3	31		
14	9	28.27	190.9	4780	39	224.2	*350	90	10.5	49.2	30		
14	9	42.65	177.7	-210	99	0.0	-0	0	10.5	49.4	30		
14	9	49.70	57.3	640	89	263.0	1760	90	10.5	49.3	31		
14	9	57.00	52.8	620	85	247.0	7990	30	10.5	49.3	30		
14	10	.61	59.4	700	84	50.5	650	77	10.5	49.2	30		
14	10	4.19	48.4	600	80	0.0	-0	0	10.5	48.9	30		
14	10	11.34	44.0	600	73	0.0	-0	0	10.5	49.5	30		
14	10	14.96	41.8	610	69	0.0	-0	0	10.5	49.4	30		
14	10	18.53	212.3	3460	61	39.6	660	60	CR2	10.5	49.7	30	
14	10	22.15	37.4	640	58	CR2	0.0	-0	0	10.5	49.7	24	
14	10	25.72	35.2	630	55	CR2	0.0	-0	0	10.5	49.4	14	
14	10	28.90	33.2	640	51	CR2	0.0	-0	0	10.5	49.9	13	
14	10	32.13	38.2	690	55	CA2	31.3	620	50	CR2	10.5	44.0	18
14	10	35.31	36.1	660	54	CA2	29.3	640	45	CR2	10.5	44.0	20
14	10	38.50	34.0	670	50	CA2	27.3	640	42	CR2	10.5	43.8	20
14	10	41.70	31.9	680	45	CA2	25.3	650	38	CR2	10.5	43.9	20
14	10	44.89	29.7	690	43	CA2	23.4	620	37	CR2	10.5	43.8	20
14	10	48.11	27.6	690	43	CA2	21.4	630	33	CR2	10.5	43.8	20
14	10	51.30	25.4	690	36	CA2	19.4	620	31	CR2	10.5	43.6	20
14	10	54.49	17.4	640	37	CB1	0.0	-0	0	10.5	43.8	15	
14	10	57.67	21.2	670	31	CA2	15.5	640	24	CB1	10.5	44.0	18
14	11	.85	19.1	670	28	CA2	13.5	620	21	CB1	10.5	43.8	20
14	11	4.04	17.1	660	25	CA1	11.6	620	18	CB1	10.5	43.8	20
14	11	7.26	15.0	650	23	CA1	9.6	640	15	CB1	10.5	43.9	20
14	11	10.45	13.0	650	20	CA1	7.6	650	11	CB1	10.5	43.9	20
14	11	13.65	11.0	640	17	CA1	5.6	630	8	CB1	10.5	44.0	20
14	11	16.84	8.9	650	13	CA1	3.6	640	5	CB1	10.5	44.0	20
14	11	20.03	7.0	620	11	CA1	1.9	570	3 13A	10.5	43.7	20	
14	11	23.25	5.1	620	8	CA1	0.0	-0	0	10.5	44.0	20	
14	11	26.44	3.3	590	5	CA1	0.0	-0	0	10.5	43.7	16	
14	11	29.62	1.8	470	3	CA1	0.0	-0	0	10.5	43.8	17	
14	11	42.79	186.9	2340	79	0.0	-0	0	10.5	49.5	31		
14	11	49.98	195.7	*460	90	251.0	5270	47	10.5	50.0	30		
14	11	53.58	216.2	880	90	0.0	-0	0	10.5	49.7	30		
14	11	57.17	183.9	560	90	0.0	-0	0	10.5	49.9	30		
14	12	22.32	260.1	2990	85	0.0	-0	0	10.5	49.5	30		
14	12	36.71	137.2	9000	20	187.6	3670	51	10.5	49.1	30		
14	12	40.28	252.2	4510	55	0.0	-0	0	10.5	49.1	31		
14	12	43.80	241.4	*460	90	0.0	-0	0	10.5	49.2	31		
14	12	58.28	55.3	-670	99	0.0	-0	0	10.5	49.0	30		
14	13	1.86	57.7	-670	99	0.0	-0	0	10.5	49.1	30		
14	13	9.05	62.6	-700	99	0.0	-0	0	10.5	49.0	31		

ENTER NO. 24

DATE 7 17

APPENDIX K

TARGET NO. 2

RANGE RATE TAU THR 2 ALT PPLS TXMT IRGN

RANGE	RATE	TAU	THR 2	ALT	PPLS	TXMT	IRGN	
0.0	-0	0		10.5	48.9	30	2034	0
0.0	-0	0		10.5	49.4	30	2037	0
0.0	-0	0		10.5	49.1	30	2037	0
0.0	-0	0		10.5	49.0	30	2060	0
0.0	-0	0		10.5	49.4	30	2077	0
0.0	-0	0		10.5	49.0	30	2003	0
0.0	-0	0		10.5	49.3	31	2063	0
0.0	-0	0		10.5	49.3	31	2071	0
24.2	*350	90		10.5	49.2	30	2034	0
0.0	-0	0		10.5	49.4	30	2072	0
263.0	1260	90		10.5	49.3	31	2053	0
267.0	7990	30		10.5	49.3	30	2024	0
50.5	650	77		10.5	49.2	30	2012	0
0.0	-0	0		10.5	48.9	30	1972	0
0.0	-0	0		10.5	49.5	30	2043	0
0.0	-0	0		10.5	49.4	30	2056	0
39.6	660	60	CR2	10.5	49.7	30	2066	T2A
0.0	-0	0		10.5	49.7	24	2069	T2A
0.0	-0	0		10.5	49.4	14	2072	T2A
0.0	-0	0		10.5	47.9	13	1855	T2B
31.3	620	50	CR2	10.5	44.0	19	1840	T2A
29.3	640	45	CR2	10.5	44.0	20	1805	T2A
27.3	640	42	CR2	10.5	43.8	20	1819	T2A
25.3	650	38	CR2	10.5	43.9	20	1841	T2A
23.4	620	37	CR2	10.5	43.8	20	1851	T2A
21.4	630	33	CR2	10.5	43.8	20	1832	T2A
19.4	620	31	CR2	10.5	43.6	20	1815	T2A
0.0	-0	0		10.5	43.8	15	1824	T1A
15.5	640	24	CR1	10.5	44.0	19	1893	T1A
13.5	620	21	CR1	10.5	43.8	20	1835	T1A
11.6	620	18	CR1	10.5	43.4	20	1836	T1A
9.6	640	15	CR1	10.5	43.9	20	1871	T1A
7.6	650	11	CR1	10.5	43.9	20	1872	T1A
5.6	630	8	CR1	10.5	44.0	20	1831	T1A
3.6	640	5	CR1	10.5	44.0	20	1859	T1A
1.9	570	3	13B	10.5	43.7	20	1813	T1A
0.0	-0	0		10.5	44.0	20	1863	T1A
0.0	-0	0		10.5	43.7	16	1814	T1A
0.0	-0	0		10.5	43.8	17	1842	T1A
0.0	-0	0		10.5	49.5	31	2099	
21.0	5270	47		10.5	50.0	30	2104	
0.0	-0	0		10.5	49.7	30	2104	
0.0	-0	0		10.5	49.9	30	2091	
0.0	-0	0		10.5	49.5	30	2114	
17.6	7670	51		10.5	49.1	30	2075	
0.0	-0	0		10.5	49.1	31	2066	
0.0	-0	0		10.5	49.2	31	2074	
0.0	-0	0		10.5	49.0	30	2039	
0.0	-0	0		10.5	49.1	30	2095	
0.0	-0	0		10.5	49.0	31	2063	

ALTITUDE  
A-3 - 11,000 FT  
P-3 - 10,500 FT  
NC-117 10,000 FT

A

FLIGHT NO. 9                      ENCOUNTER NO. 11                      DATE 7 17

TIME	TARGET NO. 1	TARGET NO. 2
HR MIN SEC	RANGE RATE FAU THR 1	RANGE RATE FAU THR 2
DTSPLAY		
12 26 37.97	51.6 350 90	0.0 -0 0
12 26 41.59	191.1 4810 39	0.0 -0 0
12 26 45.16	49.0 350 90	0.0 -0 0
12 26 48.74	83.7 -0 9	47.7 360 90
12 26 52.35	83.0 150 90	46.6 350 90
12 26 59.55	184.4 2570 71	206.6 -300 99
12 27 6.70	42.5 270 90	0.0 -0 0
12 27 10.31	41.8 230 90	0.0 -0 0
12 27 13.89	41.0 230 90	0.0 -0 0
12 27 21.08	39.7 200 90	0.0 -0 0
12 27 24.60	214.0 5390 39	244.2 6190 39
12 27 28.27	66.2 590 90	0.0 -0 0
12 27 31.85	64.3 550 90	0.0 -0 0
12 27 35.46	36.9 220 90	0.0 -0 0
12 27 39.04	60.6 520 90	36.0 240 90
12 27 42.23	56.9 540 90	34.5 240 90
12 27 49.85	55.2 510 90	0.0 -0 0
12 27 53.42	53.5 510 90	32.8 240 90
12 27 57.00	51.8 500 90	32.0 220 90
12 28 .63	50.1 470 90	31.2 230 90
12 28 4.19	48.5 450 90	30.4 240 90
12 28 7.81	46.8 480 90	29.6 230 90
12 28 11.34	45.2 470 90	28.8 250 90
12 28 14.96	43.7 450 90	28.0 220 90
12 28 18.57	42.1 440 90	27.2 240 90
12 28 22.15	40.6 440 90	26.5 220 90
12 28 25.77	39.0 460 84	25.7 200 90
12 28 29.34	37.5 450 83	24.9 230 90
12 28 32.96	36.0 440 81	24.1 220 90
12 28 36.53	34.5 420 82	23.4 220 90
12 28 40.11	33.0 420 78	22.7 200 90
12 28 43.77	31.5 430 73	21.9 220 90
12 28 47.30	30.0 440 68	21.1 220 90
12 28 50.92	28.5 470 65	20.4 220 90
12 28 54.49	27.0 440 61	19.6 220 89
12 28 57.72	25.6 430 59	19.0 200 90
12 29 .90	24.3 460 55	18.3 200 90
12 29 4.09	23.0 420 54	17.7 210 84
12 29 7.29	21.7 420 51	17.0 220 77
12 29 10.48	20.4 420 49	16.3 220 74
12 29 13.70	19.1 420 45	15.6 240 65
12 29 16.89	17.8 420 42	14.9 230 64
12 29 20.08	16.5 400 41	14.2 240 59
12 29 23.26	15.3 410 37	13.5 240 56
12 29 26.49	14.2 370 38	12.8 220 58
12 29 29.67	13.1 340 39	12.1 230 52
12 29 32.85	12.0 340 35	11.4 220 51
12 29 36.04	11.0 340 32	10.7 220 48
12 29 39.26	10.0 310 32	10.0 220 45
12 29 42.45	9.1 300 30	9.4 220 42

←117  
←A3

←117

200A 200BNT 28.5 470 65 CA2 20.4 220 90 CB2 10.5 49.3 27 207  
 200A 200BNT 27.0 440 61 CA2 19.6 220 89 CB2 10.5 49.2 20 197  
 200A 200BNT 25.6 430 59 CA2 19.0 200 90 CB2 10.5 43.7 20 176  
 200A 200BNT 24.3 460 55 CA2 18.3 200 90 CB2 10.5 43.9 20 181  
 200A 200BNT 23.0 420 54 CA2 17.7 210 84 CB2 10.5 44.0 20 181  
 200A 200BNT 21.7 420 51 CA2 17.0 220 77 CB2 10.5 48.8 20 176  
 200A 200BNT 20.4 420 49 CA2 16.3 220 74 CB2 10.5 43.8 20 171  
 200A 200BNT 19.1 420 45 CA2 15.6 240 65 CB2 10.5 43.8 20 181  
 200A 200BNT 17.8 420 42 CA2 14.9 230 64 CB2 10.5 44.0 20 181  
 200A 200BNT 16.5 400 41 CA2 14.2 240 59 CB2 10.5 48.8 20 181  
 200A 200BNT 15.3 410 37 CA2 13.5 240 56 CB2 10.5 43.7 20 181  
 200A 200BNT 14.2 370 38 CA2 12.8 220 58 CB2 10.5 48.7 20 176  
 200A 200BNT 13.1 340 39 CA2 12.1 230 52 CB2 10.5 43.8 20 171  
 200A 200BNT 12.0 340 35 CA2 11.4 220 51 CB2 10.5 43.8 20 171  
 200A 200BNT 11.0 340 32 CA2 10.7 220 48 CB2 10.5 44.1 20 181  
 200A 200BNT 10.0 310 32 CA2 10.0 220 45 CB2 10.5 43.7 20 181  
 DTVE 200BNT 9.1 300 30 CA1 9.4 220 42 CB2 10.5 43.8 20 171



FLIGHT NO. 9

ENCOUNTER NO. 11

DATE 7 17

TIME		DISPLAY	TARGET NO. 1			THR 1	TARGET NO. 2			THR 2	ALT	REFS	IXMT
HR	MIN SEC		RANGE	RATE	TAU		RANGE	RATE	TAU				
12 29	45.65	DIVE 200BNT	3.2	280	29	CA1	8.7	220	39	CB2	10.5	43.9	20 1821
12 29	48.84	DIVE 200BNTM	7.3	280	26	CA1	8.0	220	36	CB2	10.5	44.0	20 1821
12 29	52.06	LEVEL OFF NT	6.4	270	23	CA1	7.3	220	33	CB1	10.5	44.0	20 1821
12 29	55.25	LEVEL OFF NT	5.6	270	20	CA1	6.7	220	30	CB1	10.5	43.9	20 1821
12 29	58.44	LEVEL OFF NT	4.9	220	22	CA1	6.1	190	32	CB1	10.5	43.8	20 1821
12 30	1.62	LEVEL OFF NT	4.3	200	21	CA1	5.5	190	29	CB1	10.5	43.8	20 1821
12 30	4.80	LEVEL OFF NT	3.8	130	29	CA1	5.1	140	36	CB1	10.5	44.2	20 1821
12 30	8.03	LEVEL OFF NT	3.6	90	40	CA1	4.7	120	39	CB1	10.5	43.8	20 1821
12 30	11.21	LEVEL OFF NT	3.5	40	87	CA2	4.5	90	50	13R	10.5	43.8	20 1821
12 30	14.40	200A 500BNT	3.6	-50	99	CA2	4.4	50	88	13R	10.5	43.9	20 1821
12 30	17.60	200A 500BNT	3.9	-100	99	13A	4.4	-0	0	13R	10.5	43.9	20 1821
12 30	20.81	500A 500B	4.4	-130	99	13A	4.5	-50	99	13R	10.5	44.1	20 1821
12 30	23.01	500A 500B	4.8	-150	99	13A	4.8	-99	99	13R	10.5	43.8	20 1821
12 30	27.20	500A 500B	5.1	-110	99	13R	0.0	-0	0		10.5	43.9	20 1821
12 30	30.38	500B	5.5	-120	99	13R	0.0	-0	0		10.5	43.8	15 1821
12 30	33.57	500B	5.9	-150	99		0.0	-0	0		10.5	43.8	17 1821
12 30	43.55		9.0	-250	99		7.6	-170	99		10.5	43.3	30 1931
12 30	47.17		9.9	-250	99		8.2	-190	99		10.5	49.5	30 2031
12 30	50.74		10.9	-290	99		0.0	-0	0		10.5	49.5	30 2001
12 30	54.36		12.0	-310	99		9.5	-180	99		10.5	49.5	30 2051
12 30	57.97		13.1	-320	99		10.1	-170	99		10.5	49.5	30 2051
12 31	1.51		14.3	-330	99		10.7	-190	99		10.5	49.6	31 2061
12 31	5.13		15.5	-330	99		11.4	-190	99		10.5	49.6	30 2061
12 31	8.70		12.0	-180	99		195.4	+250	99		10.5	49.6	30 2061
12 31	12.28		18.0	-350	99		12.7	-190	99		10.5	49.5	30 2061
12 31	15.89		13.3	-190	99		0.0	-0	0		10.5	49.6	30 1961
12 31	19.47		14.0	-180	99		0.0	-0	0		10.5	49.6	30 2051
12 31	23.09		14.7	-210	99		0.0	-0	0		10.5	49.7	30 2041
12 31	26.66		200.8	3730	57		15.3	-200	99		10.5	49.6	30 2061
12 31	30.24		16.0	-210	99		0.0	-0	0		10.5	49.5	30 2021
12 31	33.85		16.7	-200	99		0.0	-0	0		10.5	49.3	30 2041
12 31	37.43		17.5	-220	99		0.0	-0	0		10.5	49.5	30 2051
12 31	41.04		28.4	-360	99		238.4	7760	30		10.5	49.6	30 2051
12 31	44.62		29.6	-350	99		18.9	-200	99		10.5	49.5	30 1951
12 31	48.20		39.9	-370	99		0.0	-0	0		10.5	49.5	30 2051
12 31	59.00		198.9	9280	21		0.0	-0	0		10.5	49.3	31 2021
12 32	2.54		27.6	-220	99		149.8	-880	99		10.5	49.6	30 2061
12 32	6.16		37.0	-330	99		23.3	-200	99		10.5	49.5	30 2021
12 32	9.77		38.2	-360	99		28.4	-170	99		10.5	49.5	30 2021
12 32	13.35		39.4	-340	99		0.0	-0	0		10.5	49.5	30 2061
12 32	16.96		40.7	-360	99		0.0	-0	0		10.5	49.4	31 2061
12 32	20.54		41.9	-360	99		0.0	-0	0		10.5	49.5	30 2041
12 32	24.12		43.2	-370	99		30.7	-150	99		10.5	49.4	30 2011
12 32	27.73		44.4	-340	99		223.1	1910	90		10.5	49.7	30 2061
12 32	31.31		45.7	-370	99		28.0	-190	99		10.5	49.7	30 2071
12 32	34.92		47.0	-400	99		28.7	-190	99		10.5	49.5	30 2041
12 32	38.50		48.3	-400	99		33.1	-140	99		10.5	49.2	30 1971
12 32	42.11		49.7	-380	99		0.0	-0	0		10.5	49.3	30 1961
12 32	45.69		51.1	-410	99		30.7	-180	99		10.5	49.3	31 2021
12 32	49.27		52.5	-410	99		31.4	-200	99		10.5	49.4	30 2021



A

FLIGHT NO. 9

ENCOUNTER NO. 12

DATE 7 17

TIME			TARGET NO. 1				TARGET NO. 2				ALT RPLS IXMT			
HR	MIN	SEC	DISPLAY	RANGE	RATE	TAU	THR 1	RANGE	RATE	TAU	THR 2	ALT	RPLS	IXMT
12	41	16.81		107.7	-0	13		29.6	20	90		10.5	49.8	30 2133
12	41	20.42		198.0	*520	99		0.0	-0	0		10.5	49.5	30 2079
12	41	31.21		203.2	2110	90		0.0	-0	0		10.5	49.4	30 2079
12	41	45.59		212.2	*610	99		0.0	-0	0		10.5	49.9	30 2089
12	41	52.78		221.3	4340	50		0.0	-0	0		10.5	49.4	30 2069
12	41	56.39		93.4	680	90		27.0	160	90		10.5	49.3	30 2049
12	41	59.97		26.5	180	90		0.0	-0	0		10.5	49.4	30 2069
12	42	3.58		88.8	680	90		0.0	-0	0		10.5	49.3	30 2042
12	42	14.40		199.5	6700	29		233.4	4230	55		10.5	49.6	31 2059
12	42	17.97		190.2	9460	20		0.0	-0	0		10.5	49.5	30 2029
12	42	25.20		75.3	500	90		257.2	4420	58		10.5	49.8	30 1979
12	42	28.78		73.1	620	90	A-3	22.7	140	90	117	10.5	50.0	30 2059
12	42	32.39		22.2	140	90		230.3	4370	52		10.5	49.7	31 2049
12	42	36.00		229.5	7910	29		21.6	150	90		10.5	49.9	30 2079
12	42	39.58		67.2	510	90		21.1	150	90		10.5	49.8	30 2079
12	42	43.19		20.6	150	90		0.0	-0	0		10.5	49.5	30 2049
12	42	46.79		63.6	490	90		20.1	150	90		10.5	49.7	30 2089
12	42	50.38		19.6	140	90		0.0	-0	0		10.5	49.7	30 2039
12	42	53.98		19.1	150	90		0.0	-0	0		10.5	49.7	30 2089
12	42	57.59		58.2	490	90		18.6	160	90		10.5	49.6	31 2059
12	43	1.17		56.4	510	90		18.1	130	90		10.5	49.6	31 2069
12	43	4.78		54.6	510	90		17.5	160	90	CB2	10.5	50.1	30 2119
12	43	8.30	200BNT	52.7	500	90		17.0	130	90		10.5	49.8	30 2079
12	43	11.90	200BNT	16.5	140	90	CB2	0.0	-0	0		10.5	49.5	23 2079
12	43	15.59	200BNT	16.0	140	90	CB2	0.0	-0	0		10.5	49.7	15 2109
12	43	18.70	200BNT	15.6	160	90	CB2	0.0	-0	0		10.5	44.5	15 1879
12	43	21.90	200BNT	15.2	120	90	CB2	0.0	-0	0		10.5	44.4	17 1839
12	43	25.18	200BNT	14.7	140	90	CB2	0.0	-0	0		10.5	44.3	14 1879
12	43	28.41	200BNT	14.3	130	90	CB2	0.0	-0	0		10.5	44.2	14 1849
12	43	31.59	200BNT	13.9	130	90	CB2	0.0	-0	0		10.5	44.3	17 1839
12	43	34.78	200BNT	13.5	140	90	CB2	0.0	-0	0		10.5	44.2	18 1819
12	43	38.00	200BNT	13.0	140	90	CB2	0.0	-0	0		10.5	44.2	17 1849
12	43	41.19	200BNT	12.6	140	90	CB2	0.0	-0	0		10.5	44.2	18 1859
12	43	44.41	200BNT	35.4	500	70		12.2	130	90	CB2	10.5	44.5	18 1879
12	43	47.60	200BNT	33.9	480	70		11.8	130	90	CB2	10.5	44.3	23 1859
12	43	50.82	200BNT	32.4	490	65	CB2	11.4	140	81	CB2	10.5	44.1	20 1849
12	43	54.02	200A 200BNT	30.8	500	61	CA2	10.9	140	77	CB2	10.5	44.1	20 1849
12	43	57.21	200A 200BNT	29.3	490	59	CA2	10.5	140	75	CB2	10.5	44.2	20 1859
12	44	.43	200A 200BNT	27.7	490	55	CA2	10.1	140	72	CB2	10.5	44.2	20 1859
12	44	3.62	200A 200BNT	9.6	150	64	CB2	0.0	-0	0		10.5	44.2	17 1869
12	44	6.71	200A 200BNT	24.6	510	48	CA2	9.2	130	70	CB2	10.5	44.1	18 1839
12	44	10.03	200A 200BNT	23.0	520	44	CA2	8.8	150	58	CB2	10.5	44.5	20 1849
12	44	13.22	200A 200BNT	21.3	520	40	CA2	8.4	140	60	CB2	10.5	44.1	20 1809
12	44	16.44	200A 200BNT	19.6	540	36	CA2	8.0	140	57	CB2	10.5	44.3	20 1829
12	44	19.63	200A 200BNT	17.9	550	32	CA2	7.5	150	50	CB2	10.5	44.5	20 1809
12	44	22.81	200A 200BNT	16.2	550	29	CA2	7.1	170	54	CB2	10.5	44.3	20 1839
12	44	26.03	DIVE 200BNT	14.5	550	26	CA1	6.7	130	51	CB2	10.5	44.2	20 1829
12	44	29.22	DIVE 200BNT	12.7	560	22	CA1	6.3	140	45	CB2	10.5	44.4	20 1859
12	44	32.40	DIVE 200BNT	11.0	570	19	CA1	5.9	140	42	CB2	10.5	44.2	20 1849
12	44	35.62	DIVE 200BNT	9.3	540	17	CA1	5.5	130	42	CB2	10.5	44.1	20 1809



FLIGHT NO. 9

ENCOUNTER NO. 13

DATE 7 17

TIME		TARGET NO. 1					TARGET NO. 2								
HR	MIN SEC	DISPLAY	RANGE	RATE	TAU	THR 1	RANGE	RATE	TAU	THR 2	ALT	RPLS	TXMT	I	
12 44	38.81	DIVE 200BNT	7.6	530	14	CA1	5.1	120	42	CB2	10.5	44.3	20	1874	
12 44	42.00	LEVEL OFF NT	5.9	540	10	CA1	4.7	120	39	CB1	10.5	44.2	20	1849	
12 44	45.22	LEVEL OFF NT	4.4	500	8	CA1	4.3	130	33	CB1	10.5	44.2	20	1850	
12 44	48.42	LEVEL OFF NT	2.9	450	6	CA1	3.9	120	32	CB1	10.5	44.0	20	1828	
12 44	51.61	LEVEL OFF NT	2.0	280	7	CA1	3.6	120	30	CB1	10.5	44.2	20	1836	
12 44	54.83	LEVEL OFF NT	3.3	110	30	CB1	0.0	-0	0		10.5	44.3	20	1865	
12 44	58.02	500ACLINBNT	3.3	-350	99	13A	3.0	100	30	CB1	10.5	44.2	20	1860	
12 45	1.11	CLINBNT	2.8	90	31	17B	0.0	-0	0	9.6	10.5	44.1	15	1848	
12 45	4.43	500B	2.6	90	29	13B	0.0	-0	0	9.5	10.5	44.1	15	1839	
12 45	7.62	500B	2.4	70	34	13B	0.0	-0	0	"	10.5	44.2	15	1865	
12 45	10.70	500B	2.1	90	23	13B	0.0	-0	0	"	10.5	44.0	14	1868	
12 45	14.02	500B	1.8	90	20	13B	0.0	-0	0	"	10.5	44.3	14	1856	
12 45	17.21	500B	1.5	100	15	13B	0.0	-0	0	"	10.5	44.0	15	1824	
12 45	20.39	500B	1.3	80	16	13B	0.0	-0	0	"	10.5	44.1	14	1833	
12 45	23.61	500B	1.1	50	22	CR1	0.0	-0	0	9.7	10.5	44.3	14	1866	
12 45	26.80	CLINBNT	1.0	20	50	CB1	0.0	-0	0	"	10.5	44.5	14	1882	
12 45	29.99	CLINBNT	1.1	-40	99	CB1	0.0	-0	0	"	10.5	44.3	14	1844	
12 45	33.21	CLINBNT	1.3	-70	99	13B	0.0	-0	0	9.6	10.5	44.1	15	1835	
12 45	36.41	500B	1.6	-90	99	13B	0.0	-0	0	"	10.5	44.3	14	1826	
12 45	39.60	500B	1.9	-90	99	13B	0.0	-0	0	"	10.5	44.2	15	1858	
12 45	42.82	500B	2.2	-110	99	CR1	0.0	-0	0	9.7	10.5	44.0	14	1844	
12 45	45.01	CLINBNT	2.6	-100	99	CB1	0.0	-0	0	"	10.5	44.2	14	1865	
12 45	49.20	CLINBNT	3.0	-120	99	CA1	0.0	-0	0	"	10.5	44.3	15	1856	
12 45	52.38	CLINBNT	3.4	-120	99	CB2	0.0	-0	0	9.7	10.5	44.0	14	1847	
12 45	55.51	200BNT	3.8	-130	99	CB2	0.0	-0	0	"	10.5	44.2	14	1849	
12 45	58.79	200BNT	4.1	-120	99	CB2	0.0	-0	0	"	10.5	44.2	14	1854	
12 46	1.97	200BNT	4.5	-120	99	13B	0.0	-0	0	9.6	10.5	43.9	15	1832	
12 46	5.10	500B	4.9	-120	99	17B	0.0	-0	0	"	10.5	43.9	17	1834	
12 46	8.38	500B	5.2	-120	99	13B	0.0	-0	0	"	10.5	43.8	15	1840	
12 46	11.57	500B	5.6	-120	99	13B	0.0	-0	0	"	10.5	43.8	14	1867	
12 46	14.79	500B	5.9	-120	99	17B	0.0	-0	0	"	10.5	43.8	14	1847	
12 46	17.98	500B	6.3	-120	99	13B	0.0	-0	0	"	10.5	43.5	14	1823	
12 46	21.18	500B	6.7	-120	99		0.0	-0	0	"	10.5	43.8	14	1801	
12 46	24.37		7.1	-120	99		0.0	-0	0	"	10.5	44.0	15	1870	
12 46	27.59		7.6	-140	99		0.0	-0	0	"	10.5	44.0	24	1838	
12 46	31.17		53.0	-600	99		8.0	-140	99	"	10.5	49.5	30	2072	
12 46	34.78		55.0	-570	99		8.5	-120	99	"	10.5	49.6	30	2083	
12 46	38.36		57.1	-570	99		9.0	-190	99	"	10.5	49.4	30	2063	
12 46	41.97		59.0	-540	99		9.4	-140	99	"	10.5	49.3	30	2042	
12 46	45.55		61.2	-590	99		9.9	-130	99	"	10.5	49.5	30	2057	
12 46	49.16		63.3	-590	99		10.4	-140	99	"	10.5	49.4	31	2055	
12 46	52.74		65.3	-570	99		10.9	-140	99	"	10.5	49.7	30	2086	
12 46	56.34		67.3	-600	99		11.4	-170	99	"	10.5	49.7	30	2072	
12 46	59.93		69.3	-600	99		12.0	-160	99	"	10.5	49.6	30	2073	
12 47	3.53		71.2	-550	99		12.5	-150	99	"	10.5	49.5	30	2077	
12 47	7.12		73.2	-570	99		12.9	-130	99	"	10.5	49.7	30	2085	
12 47	10.72		75.2	-570	99		13.5	-160	99	"	10.5	49.7	30	2074	
12 47	14.30		77.1	-510	99		14.0	-150	99	"	10.5	49.3	30	2068	
12 47	17.91		79.8	-580	99		14.5	-140	99	"	10.5	49.6	30	2090	
12 47	21.49		81.0	-490	99		15.0	-140	99	"	10.5	49.7	30	2074	

