

AD-A014 273

**ESTIMATING THE PERFORMANCE CAPABILITY
OF 50,000-LB-CAPACITY CONTAINER HANDLER
ON BEACH AND DESERT SANDS**

Edgar S. Rush, et al

**Army Engineer Waterways Experiment Station
Vicksburg, Mississippi**

August 1975

DISTRIBUTED BY:

NTIS

**National Technical Information Service
U. S. DEPARTMENT OF COMMERCE**

**Best
Available
Copy**

254096



MISCELLANEOUS PAPER M-75-8

ESTIMATING THE PERFORMANCE CAPABILITY OF 50,000-LB-CAPACITY CONTAINER HANDLER ON BEACH AND DESERT SANDS

by

Edgar S. Rush, Gary N. Durham

Mobility and Environmental Systems Laboratory
U. S. Army Engineer Waterways Experiment Station
P. O. Box 631, Vicksburg, Miss. 39180

August 1975

Final Report

Approved For Public Release; Distribution Unlimited

AD A014273

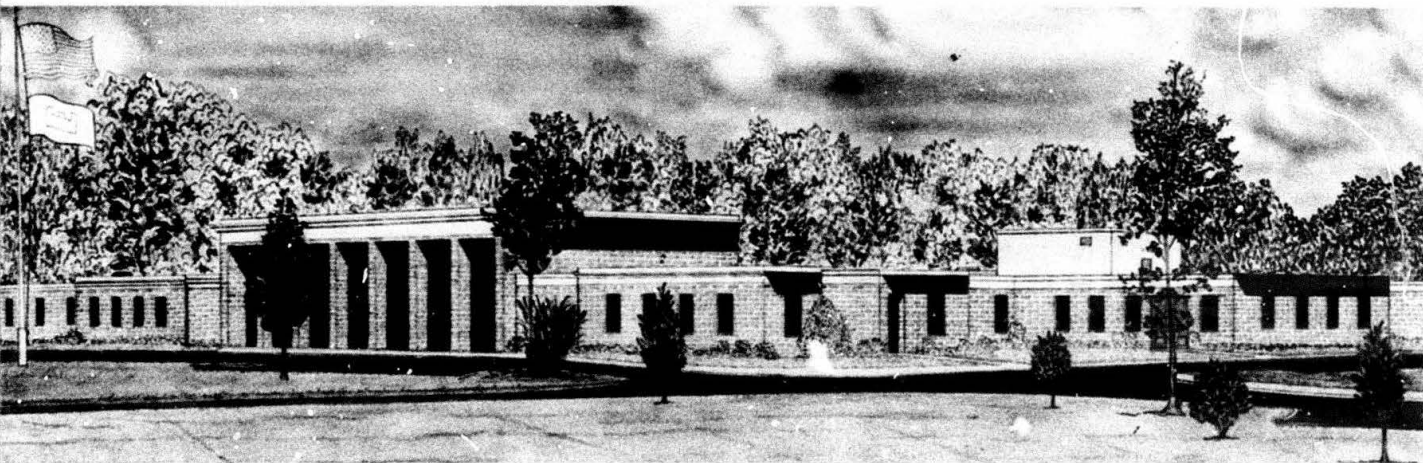

Prepared for U. S. Army Mobility Equipment Research and
Development Center, Fort Belvoir, Va. 22060

Reproduced by
NATIONAL TECHNICAL
INFORMATION SERVICE
U. S. Department of Commerce
Springfield VA 22151

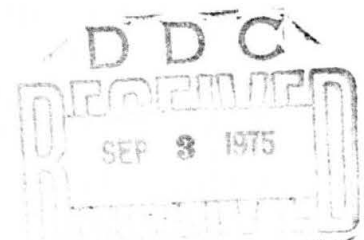

95

Unclassified

SECURITY CLASSIFICATION OF THIS PAGE(When Data Entered)

20. ABSTRACT (Continued).

analysis of data includes variations in soil strength that occur in dry-to-moist sands, the variations that occur according to beach location, variation between beach and desert sands, and variation between sand types. Also included is a discussion of the areal distribution of beach and desert sands on a worldwide basis, the factors affecting sand stabilization, and some of the more pertinent stabilization methods. By using verified vehicle performance evaluation procedures and methodology that considers the effects of tire inflation pressure, surface slopes, frequency of occurrences, and sand strength and type, the performance of a wheeled dozer, modified for handling containers, can be estimated on an areal basis. Practical stabilization of beach sands can be achieved by densification of the sand, by the introduction of cementing agents to increase sand bearing capacity, or by construction of temporary roadways. Current design and evaluation methods employed in stabilizing natural soils for road and airfield construction are not entirely applicable for designing expedient stabilized beach sand sections for transportation thoroughways. Appendix A presents a list of selected references concerning soil stabilization.

Unclassified

SECURITY CLASSIFICATION OF THIS PAGE(When Data Entered)

THE CONTENTS OF THIS REPORT ARE NOT TO BE
USED FOR ADVERTISING, PUBLICATION, OR
PROMOTIONAL PURPOSES. CITATION OF TRADE
NAMES DOES NOT CONSTITUTE AN OFFICIAL EN-
DORSEMENT OR APPROVAL OF THE USE OF SUCH
COMMERCIAL PRODUCTS.

PREFACE

The study reported herein was conducted during May-September 1974 by the U. S. Army Engineer Waterways Experiment Station (WES) for the U. S. Army Mobility Equipment Research and Development Center (MERDC), Material Handling Equipment Development Branch, Fort Belvoir, Virginia.

The study was conducted by personnel of the Mobility Systems Division (MSD) of the Mobility and Environmental Systems Laboratory (MESL) under the general supervision of Messrs. A. A. Rula, Chief, MSD, and W. G. Shockley, Chief, MESL. The report was prepared by Messrs. E. S. Rush and G. N. Durham of MSD.

Acknowledgment is made to Messrs. James Blanchfield, W. F. Clark, and Gary Hicks, all of MERDC, for coordination and assistance in connection with the study.

COL G. H. Hilt, CE, was Director of WES and Mr. F. R. Brown was Technical Director during conduct of the study and preparation of the report.

CONTENTS

	<u>Page</u>
PREFACE	2
CONVERSION FACTORS, U. S. CUSTOMARY TO METRIC (SI) AND METRIC TO U. S. CUSTOMARY UNITS OF MEASUREMENT	4
PART I: INTRODUCTON	5
Background	5
Purpose	7
Scope	7
Definitions	8
PART II: ESTIMATE OF VEHICLE PERFORMANCE ON NATURAL SAND BEACHES AND DESERTS	15
Vehicle Data Considered	15
Sand Data	20
Analysis of Data	20
Summary Discussion	42
PART III: STABILIZATION OF BEACH SANDS FOR OPERATION OF CONTAINER HANDLING EQUIPMENT	44
Factors Affecting Beach Stabilization	45
Prediction of Trafficability on Beach Sands	50
Beach Stabilization for Trafficability Purposes	59
PART IV: CONCLUSIONS AND RECOMMENDATIONS	69
Conclusions	69
Recommendations	70
REFERENCES	72
TABLES 1-7	
APPENDIX A: SELECTED REFERENCES CONCERNING SOIL STABILIZATION	

**CONVERSION FACTORS, U. S. CUSTOMARY TO METRIC (SI) AND
METRIC TO U. S. CUSTOMARY UNITS OF MEASUREMENT**

U. S. Customary units of measurement used in this report can be converted to metric (SI) units as follows:

<u>Multiply</u>	<u>By</u>	<u>To Obtain</u>
inches	2.54	meters
square inches	6.4516	square meters
feet	0.3048	meters
miles	1.609344	kilometers
square miles	2.5899	square kilometers
gallons (U. S. liquid)	3.785	liters
pounds (mass)	0.45359	kilograms
kip (mass)	453.5924	kilograms
pounds (force)	4.4482	newtons
pounds (force) per square inch	6.8948	kilopascals
pounds per cubic inch	0.2714	meganewtons per cubic meter

Metric units can be converted to U. S. Customary units as follows:

<u>Multiply</u>	<u>By</u>	<u>To Obtain</u>
millimeters	0.0394	inches

ESTIMATING THE PERFORMANCE CAPABILITY OF 50,000-LB-
CAPACITY CONTAINER HANDLER ON BEACH AND DESERT SANDS

PART I: INTRODUCTION

Background

1. Full-scale containerization of Army cargo is expected in the years ahead to coincide with the growing fleet of containerships. In current programs and exercises, equipment and procedures are being investigated for discharging containers from containerships and moving them across beaches in logistic over-the-shore operations. An integral part of the total containerization program is the examination of materials handling equipment being conducted by the Army Materiel Command's (AMC's) Mobility Equipment Research and Development Center (MERDC) at Fort Belvoir, Virginia.¹

2. There is a requirement for development of a 50,000-lb*-capacity rough-terrain container handler capable of operation in off-road environments such as sand beaches and deserts. To develop such a piece of equipment effectively, there is a need for quantitatively identifying the vehicle characteristics that affect its mobility and thereby establish optimum design criteria. To aid in equipment development, a Model 824B wheeled dozer manufactured by Caterpillar Tractor Co. was equipped with a container handler mast in place of the dozer blade assembly (Figure 1).

3. The modified 824B (referred to throughout this report as the CAT 824) was subsequently tested on natural sand beaches at Fort Story and Little Creek, Virginia. Results of these tests^{2,3} indicated that performance of the CAT 824 over the beaches was marginal to poor when the standard construction equipment tires were operated at the manufacturer's recommended high tire inflation pressures but was greatly improved when

* A table of factors for converting U. S. Customary units of measurement to metric (SI) units and metric to U. S. Customary is given on page 4.



Figure 1. 50,000-lb rough-terrain container handler

it was equipped with radial-ply tires capable of operating at low inflation pressures. In that test program vehicle performance in terms of maximum drawbar pull, maximum slope negotiable, and go or no-go were related to the soil strength parameter cone index. Results of these performance tests were compared to performance estimated with an empirically derived formula that is currently used in the soil submodel of the AMC comprehensive ground mobility model (called AMC-71).⁴ The study reported herein was conducted to obtain some first order general estimates, from the Little Creek testing,³ of the expected performance on other beach or desert sands; and if expected performance was on a marginal or submarginal basis, to determine the engineering effort that would be required in terms of soil stabilization to make those sands usable to some acceptable level of performance.

Purpose

4. The specific purposes of this study were to:
 - a. Summarize worldwide beach and desert sand conditions and relate these to probable performance capabilities of the 50,000-lb-capacity container handler CAT 824 (gross weight, 160,000 lb).
 - b. Review methods to improve the properties of beach sand to render it trafficable for wheeled vehicles having single wheel loads in excess of 50,000 lb.

Scope

5. For the analysis of worldwide beach and desert sand conditions, the literature was searched for existing information in the form needed for vehicle performance evaluations. Except for information on the areal distribution of sands, the majority of usable data is contained in four U. S. Army Engineer Waterways Experiment Station (WES) reports.⁵⁻⁸

From data in these reports three statistical analyses of the variations in soil strength that occur in dry-to-moist sands were obtained. The three analyses are: (a) variation according to sand type (beach sands only), (b) variation according to the location of the sand on a beach, and (c) variation between beach and desert sands (quartz sand only). Also included in the analyses is a discussion of the areal distribution of beach and desert sands.

6. For the analysis of effects of soil stabilization on performance, a review was made of factors affecting sand stabilization and some of the more practical stabilization methods are discussed.

Definitions

7. Certain terms used in this report are defined below.

Soil terms pertaining to classification⁹

8. In the Unified Soil Classification System, the words "cobbles," "gravel," "sand," and "finer (silt and clay)" are used to designate the size ranges of soil particles. The gravel and sand ranges are further subdivided into the groups presented below. The limiting boundaries between the various size ranges have been arbitrarily set at certain U. S. standard sieve sizes.

- a. Cobbles. Soil particle sizes larger than 3 in.
- b. Gravel.
 - (1) Coarse gravel. Soil particles that range in size from 3 in. to 3/4 in.
 - (2) Fine gravel. Soil particles that range in size from 3/4 in. to No. 4 sieve (4.76 mm).
- c. Sand.
 - (1) Coarse sand. Soil particles that range in size from No. 4 sieve (4.76 mm) to No. 10 sieve (2.0 mm).
 - (2) Medium sand. Soil particles that range in size from No. 10 sieve (2.0 mm) to No. 40 sieve (0.42 mm).
 - (3) Fine sand. Soil particles that range in size from No. 40 sieve (0.42 mm) to No. 200 sieve (0.074 mm).

- d. Fines (silt or clay). Soil particle sizes smaller than No. 200 sieve (0.074 mm).
- e. Coarse-grained soil. A soil of which more than 50 percent (by weight) of the particles will be retained on a No. 200 sieve (larger than 0.074 mm).
- f. Fine-grained soil. A soil of which more than 50 percent (by weight) of the particles will pass a No. 200 sieve (smaller than 0.074 mm).
- g. Symbol "SP." A clean sand (containing less than 5 percent fines) predominantly of one size or a range of sizes with some intermediate sizes missing.
- h. Symbol "SW." A clean sand with a wide range in particle sizes and substantial amounts of all intermediate particle sizes.

Soil terms pertaining to stabilization

9. Soil terms pertaining to stabilization are as follows:

- a. California Bearing Ratio (CBR). A measure of shear strength and bearing capacity of soil. It is determined by comparing the bearing value obtained from a penetration-type shear test with a standard bearing value obtained on crushed rock. The standard results are taken as 100 percent, and values obtained from other tests are expressed as percentages of the standard.
- b. Angle of internal friction (ϕ). A measure of the shearing strength of soil on an internal surface that is proportional to the normal pressure.
- c. Bearing capacity, ultimate. The average load per unit of area on a footing required to produce failure by rupture of a supporting soil mass.
- d. Cohesion (c). The shearing strength of soil on an internal surface that is independent of the normal stress.
- e. Cohesionless soil. A soil that has shearing strength due primarily to internal friction and has negligible cohesion.

The soil can be identified as having little or no cohesion when submerged.

- f. Cohesive soil. A soil that has shearing strength due primarily to cohesion and negligible internal friction. This soil can be identified as having significant cohesion when submerged.
- g. Compaction. The densification of soil by means of mechanical manipulation, which results in the reduction of air voids in the soil.
- h. Coulomb's equation. The relation between the shear strength, s , of soil and the effective stress, $\bar{\sigma}$, on an internal surface. The equation is written $s = c + \bar{\sigma} \tan \phi$, where c is cohesion and ϕ is angle of internal friction.
- i. Dry density (unit dry weight or bulk density) (γ_d). The weight of soil solids, W_s , per unit of total volume of soil mass, V_T ; that is, $\gamma_d = W_s/V_T$.
- j. Percent saturation (S). The ratio, expressed as a percentage, of the volume occupied by water in a given soil mass, V_w , to the total volume of void space; that is, $S = [V_w/(V_w + V_a)] 100$ where V_w and V_a are volumes of water and air, respectively.
- k. Plasticity. The property of a soil that allows it to be permanently deformed without cracking or appreciable volume change.
- l. Relative density, D_r . The ratio of the difference between the void ratio of a cohesionless soil in the loosest state, e_{max} , and any given void ratio, e , to the difference between the void ratios of the soil in the loosest state, e_{max} , and in the densest state, e_{min} ; that is, $D_r = (e_{max} - e)/(e_{max} - e_{min})$.

- m. Shear strength (s). The maximum resistance of a soil to shearing stresses.
- n. Void ratio (e). The ratio of the volume of void space to the volume of solid particles in a given soil mass, V_s ; that is, $e = (V_a + V_w)/V_s$.
- o. Water content (moisture content)(w). The ratio expressed as a percentage, of the weight of water in a given soil mass, W_w , to the weight of solid particles, W_s ; that is, $w = (W_w/W_s) 100$.
- p. Wet density (unit wet weight)(γ_w). Weight of the soil solids and water, W_T , per unit of total volume of soil mass, V_T ; that is, $\gamma_w = W_T/V_T$.

Soil terms pertaining to trafficability

- 9. Soil terms pertaining to trafficability are as follows:
 - a. Trafficability. The capacity of a soil to support the traffic of military vehicles.
 - b. Bearing capacity. The ability of a soil to support a vehicle without undue settlement of the vehicle.
 - c. Traction capacity. The ability of a soil to resist the traction elements of a vehicle to furnish the necessary thrust required for propulsion and steering.
 - d. Cone index (CI). An index of the shearing resistance of soil obtained with a cone penetrometer. The value represents the resistance of the soil to penetration of a 30-deg cone with 1/2-sq-in. base area (actually load in pounds on cone base area in square inches).
 - e. Critical layer. The soil layer in which the cone index is considered the most significant measure of trafficability. Its depth may vary with the soil strength profile and with certain vehicle characteristics such as weight, tire/track size, etc.

- f. Cone penetration resistance gradient (G). An index of soil strength for essentially coarse-grained soils (sands). It is the slope of the curve of penetration resistance versus depth, averaged over that depth range in which changes in soil strength significantly affect vehicle performance.
- g. Liquefaction. The puddling and drastic reduction in strength of saturated (although initially firm) sand under loading. The combined effects of wetness, structure, and fineness of the sand and on presence of silt may prevent the sand from draining fast enough to maintain intergranular friction when a dynamic load is applied, thus causing pore pressure to develop and the sand to liquefy.

Beach terms

- 10. Beach terms used in this report are as follows:
 - a. Foreshore. That part of the beach ordinarily traversed by the uprush and downrush of waves as the tide rises and falls.
 - b. Backshore. That part of the beach between the foreshore and the forward dune apron (if present) of the shoreline.
 - c. Forward dune apron. The concave seaward slope of a line of dunes.
 - d. Dune area. An area of wind-deposited sand inland from the forward dune apron. Coastal dunes may be active or partially stabilized by vegetation.

Sand moisture classification terms

- 11. Sand moisture classification terms are as follows:
 - a. Dry sand. Sand that is light-colored, loose, and free-flowing when poured from the hand. Dry sand usually occurs on the surface of all components of beaches, except the foreshore, but never extends deeper than 5 in. before becoming moist. Sand classed as dry on the

basis of visual observation usually contains less than 1.5 percent moisture by weight.

- b. Wet sand. Sand on the foreshore that is wetted by waves but is not under a finite depth of water at all times. Wet sand exhibits some cohesion, and free water can be squeezed out of it.
- c. Inundated sand. Sand covered by water at some specific time. A spot on the foreshore inundated at one moment during the uprush of a wave will become wet a few seconds later when the wave recedes.
- d. Quick-condition sand. Loose, wet, or more commonly, inundated sand that becomes liquefied under a moving vehicle.

Vehicle terms

12. Vehicle terms used in this report are as follows:

- a. Vehicle performance. The maximum drawbar pull that a vehicle can exert or the maximum slope it can climb on a given soil condition.
- b. Pass. One trip of a vehicle over an area.
- c. Immobilization. Failure of a self-propelled vehicle to travel forward over sand, although it could possibly back up in its ruts. Immobilizations are also considered to occur whenever the drive wheels begin to jerk violently and the vehicle progresses forward very slowly.
- d. Maximum towing force (maximum drawbar pull). The maximum amount of sustained towing force a self-propelled vehicle can produce at its drawbar under given test conditions. It is termed "tractive coefficient" when expressed as a ratio of the drawbar pull (in pounds) to the gross weight of the vehicle (in pounds).
- e. Slip. The percentage of tire or track movement ineffective in advancing a vehicle forward.

f. Vehicle cone index (VCI). An index assigned to a given vehicle, based on certain vehicle characteristics, that indicates the minimum soil strength in terms of rating cone index (for fine-grained soils) or cone index (for coarse-grained soils) required for a prescribed number of passes. VCI for coarse-grained soils is distinguished from VCI for fine-grained soils by the addition of an "S." Furthermore, numbers are used to distinguish the VCI's for one inflation pressure from another, e.g. VCIS-35 and VCIS-72.5 are the VCI's for 35- and 72.5-psi tire inflation pressures on sand, respectively. VCIS applies to one pass only-VCI for fine-grained soil is identified for a given number of passes by a subscript; i.e. usually VCI_1 or VCI_{50} .

PART II: ESTIMATE OF VEHICLE PERFORMANCE ON
NATURAL SAND BEACHES AND DESERTS

Vehicle Data Considered

Vehicle characteristics

13. Only one vehicle, the modified CAT 824 (Figure 1), was considered in this study; however, the approach followed in the analysis for the CAT 824 could be followed for other vehicles if desired. The CAT 824 is a modified 924B wheeled dozer (paragraph 2), intended to be used as a container handler by replacing the dozer assembly with an overhanging mast capable of lifting 8-ft by 8-ft by 20-ft containers from the top.

14. Pertinent vehicle characteristics are given in Table 1. Certain other characteristics not given in the table were desired but were not available for inclusion in this report, the main one being tire deflection-load curves for both standard and radial-ply tires.

Vehicle performance data

15. Based on results of the tests in reference 2 (paragraph 3) and performance estimated with empirically derived formulas (Table 2), performance parameters for various soil strengths were determined as described below. For this report it was desirable to use maximum slope negotiable as the performance parameter. The conversion from maximum drawbar pull to maximum slope negotiable (maximum pull in percent of gross weight minus 2 percent equals maximum slope negotiable) has been established in previous reports on sand trafficability.^{7,8}

16. Performance at 72.5-psi average tire inflation pressure. The recommended tire inflation pressures with standard tires was 90 psi for the front tires (heaviest axle load when loaded to capacity) and 55 psi for the rear tires. The average inflation pressure was thus 72.5 psi, one of the values used in the analysis. Results of analysis of data in

reference 2 indicated that measured and predicted performance of the CAT 824 could be correlated best with cone index of the 0- to 12-in. layer. Pertinent data from those tests are shown in the following tabulation.

<u>Test No.</u>	<u>Cone Index 0- to 12-in. Layer</u>	<u>Maximum Drawbar Pull, %</u>	<u>Maximum Slope Negotiable, % (Maximum Pull Minus 2%)</u>
4	223	5.4	3.4
5	371	10.0	8.0
6	355	13.2	11.2
12	223	3.8	1.8
13	355	7.0	5.0

17. In addition to the above data, results of three tests (two maximum drawbar pull tests and one maximum slope negotiable test) reported in reference 3 for 72.5-psi inflation pressure are summarized in the following tabulation. The analysis in reference 3 also shows that at inflation pressures of 72.5 psi the critical layer is the 0- to 12-in. layer.

<u>Test No.</u>	<u>Cone Index 0- to 12-in. Layer</u>	<u>Maximum Drawbar Pull, %</u>	<u>Maximum Slope Negotiable, % (Maximum Pull Minus 2%)</u>
31	192	4.0	2.0
32	192	4.5	2.5
38	182	-	7.3

18. The cone index data in the two tabulations above are plotted versus the maximum slope negotiable data in Figure 2, along with the computed performance curve, using the maximum slope negotiable formula in Table 2. Although there is some scatter, the data points fit the computed curve reasonably well; therefore, the curve will be used in subsequent analyses as the performance curve for 72.5-psi average inflation pressure. The computed VCIS-72.5 of 146 will also be used.

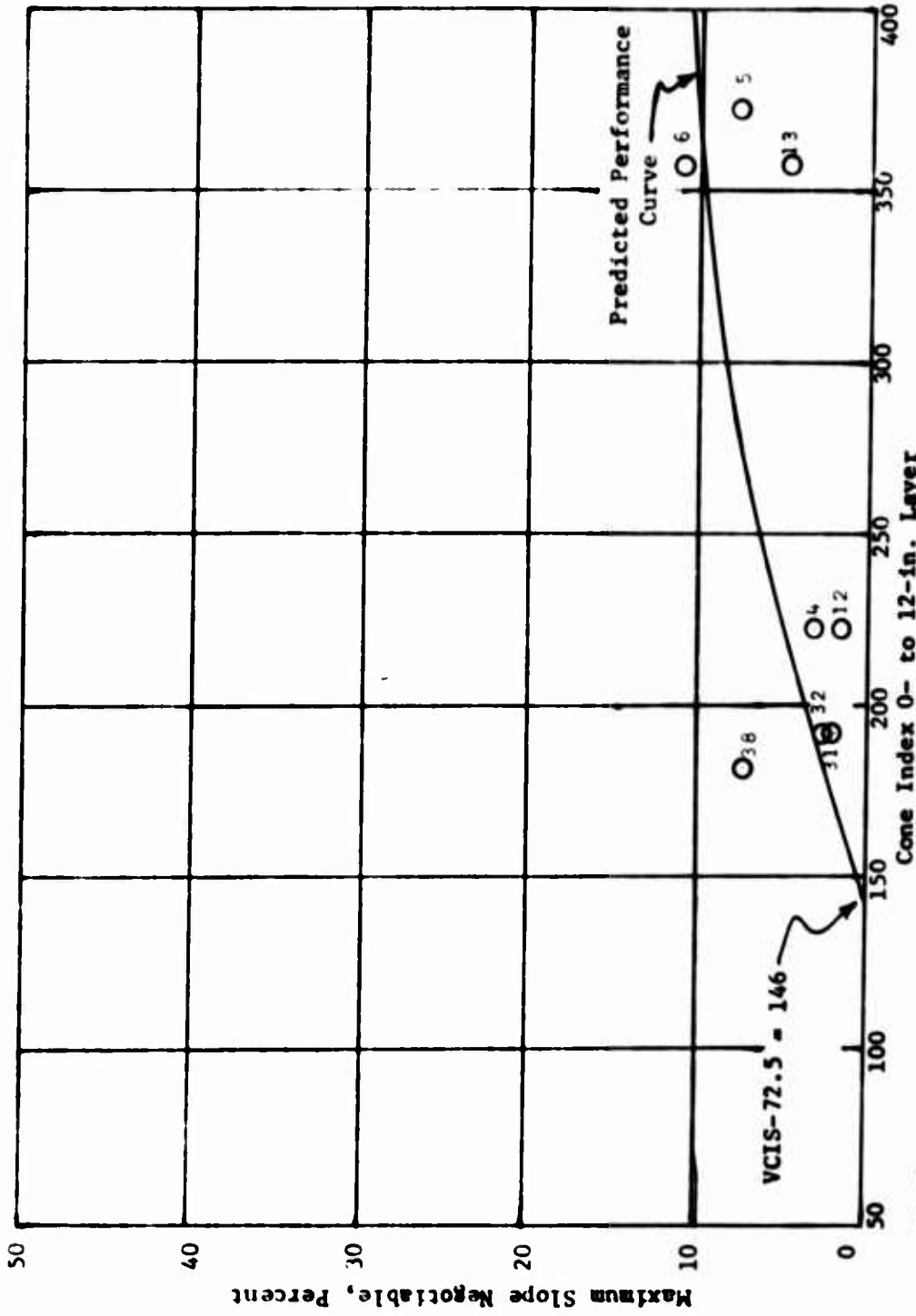

Cone Index 0- to 12-in. Layer

Numbers near plotted points are test numbers from paragraphs 16 and 17.

O - Standard tires

Figure 2. Cone index versus maximum slope negotiable, CAT 824, 72.5-psi average inflation pressure

19. Performance at 35-psi average tire inflation pressure. The performance curve for 35-psi average inflation pressures was not as easily derived as the curve for 72.5 psi. Previous test results³ indicate that the critical layer is the 0- to 6-in. layer for inflation pressures less than about 45 psi. Development of the 35-psi performance curve is given below. Data considered were from reference 3 and are summarized in the following tabulation.

<u>Test No.</u>	<u>Average Tire Inflation Pressure psi</u>	<u>Cone Index 0- to 6-in. Layer</u>	<u>Maximum Drawbar Pull, %</u>	<u>Maximum Slope Negotiable, % (Maximum Pull Minus 2%)</u>
<u>Standard Tires</u>				
36	35	64	12.0	10.0
41	35	66	11.5	9.5
42	35	66	12.0	10.0
49	35	105	-	14.2
50	35	92	-	14.0
51	35	83	-	14.2

20. The cone index data above are plotted versus the maximum slope negotiable in Figure 3. Also shown in Figure 3 are the predicted and the experimental performance curves for 35-psi inflation pressure. The upper (predicted) curve was determined from the maximum slope negotiable formula in Table 2. The lower (experimental) curve was determined primarily as the line of best fit through the data points that would also parallel the predicted curve. As indicated by the measured data points, the predicted curve is too optimistic; therefore, the experimental performance curve will be used for subsequent analyses. Performance data on radial-ply tires at 35-psi were not available, but comparisons of performance between standard-ply and radial-ply tires at the same inflation pressures indicate better performance with the radial-ply

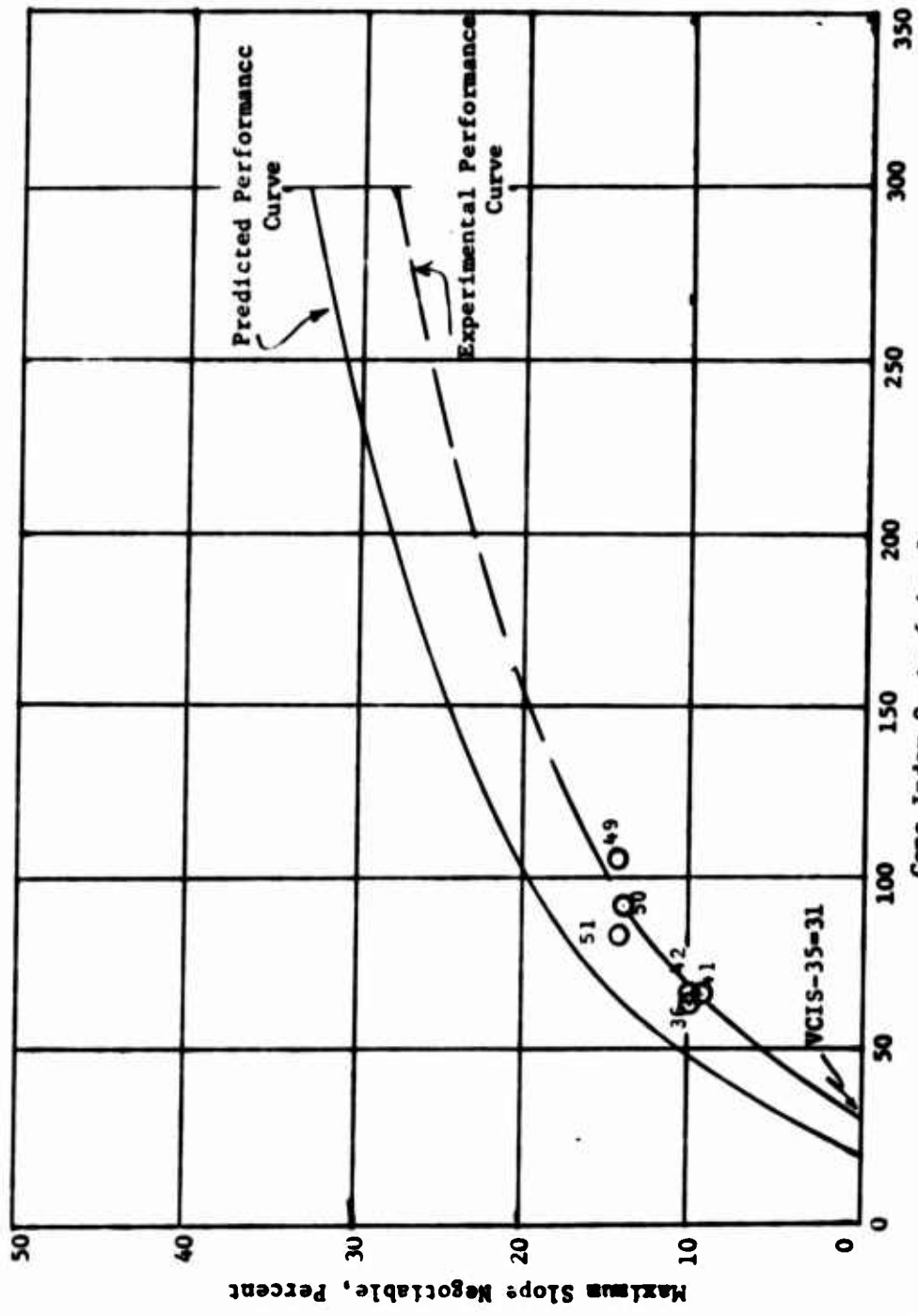

Numbers near plotted points
are test numbers from paragraph 19.

Figure 3. Cone index versus maximum slope negotiable, CAT 824, 35-psi average inflation pressure

tire. It is very possible that radial-ply performance data would fit the predicted 35-psi curve. Also, it is very possible that in order for the vehicle equipped with construction equipment tires to operate at low inflation pressures, radial-ply tires will have to be used. For the present, however, it is believed that the more conservative, experimentally developed 35-psi curve should be used. Therefore, for subsequent analysis herein, maximum slope negotiable will be used from experimental curves and VCIS-35 is considered to be 31.

Sand Data

21. Available beach and desert sand data from previously published reports that were pertinent to the analysis herein are summarized in Table 3. Sands with usable data were primarily of quartz origin; however, data from sands of volcanic and coral origin are also presented. The data in Table 3 were compiled from individual tests. Usually for a given test the cone index value for the 0- to 6- or the 0- to 12-in. depth was the average of at least five penetrations or 15 individual cone index readings in an approximate 10-ft by 25-ft area. The values of cone index range are values obtained from individual sets of cone index profiles readings taken in the sampled area, and the average cone index values are the average values of all individual tests. The sand data were obtained during vehicle testing programs rather than specifically for the purpose of statistical analysis; hence, some areas are more heavily represented by data than others. Also, loose, soft sands were deliberately sought in most vehicle programs, so there is some bias in that direction; this fact should be recognized when data herein are compared with the probable occurrence on a worldwide or a more localized areal basis.

Analysis of Data

22. The analysis of data covers: (a) frequency of occurrence of cone index ranges on natural sands, i.e. according to beaches, portions of beaches (foreshore, etc.), and deserts; (b) estimates of

performance of the CAT 824 on the sand areas listed in (a) above; (c) world-wide distribution of sand beaches and deserts; and (d) discussion of beach stabilization for trafficability purposes.

Frequency of occurrence of cone index ranges on natural sands

23. The frequency of occurrence of cone index ranges in the 0- to 6-in. layer was compiled for and reported in reference 8. The cumulative frequency of occurrence of cone index ranges of dry-to-moist sand in the 0- to 6-in. layer has been reproduced in Table 4. Data from the same tests also were used to compile the cumulative frequency of occurrence of cone index ranges in the 0- to 12-in. layer (Table 5). The number of samples in each sand area category are shown at the bottom of Tables 4 and 5. Cone index values were grouped into ranges of 10 units each, as shown in the tables, and the cumulative percentages were computed for each sand area category. Data presented in Tables 4 and 5 are shown as frequency distribution curves in Figures 4-17. The curves were drawn by plotting the midpoint of each cone index range versus the cumulative frequency.

24. On the average, for a given layer (0- to 6- or 0- to 12-in.) quartz sands are stronger than volcanic sands, which are, in turn, stronger than coral sands. For specific beach areas (foreshore, etc.), quartz sands are the strongest, with volcanic and coral sands having generally the same strength. In a comparison of frequency distributions of strength of quartz beaches (including all beach areas) and deserts, the strengths of the 0- to 6-in. layers are about the same, and the beach 0- to 12-in. layer is stronger than the same layer of desert sand.

Estimate of performance of CAT 824 on natural sands

25. Measured and predicted performance capabilities of the CAT 824 on specific beach areas are discussed in paragraphs 15-20. By using the predicted performance curves, the probability of the vehicle to go if it encounters a specific situation can be estimated. In Figures 3 and 2, respectively, it was determined that $VCIS-35 = 31$ and $VCIS-72.5 = 146$. This means that cone indexes of 31 and 146 are required for the vehicle

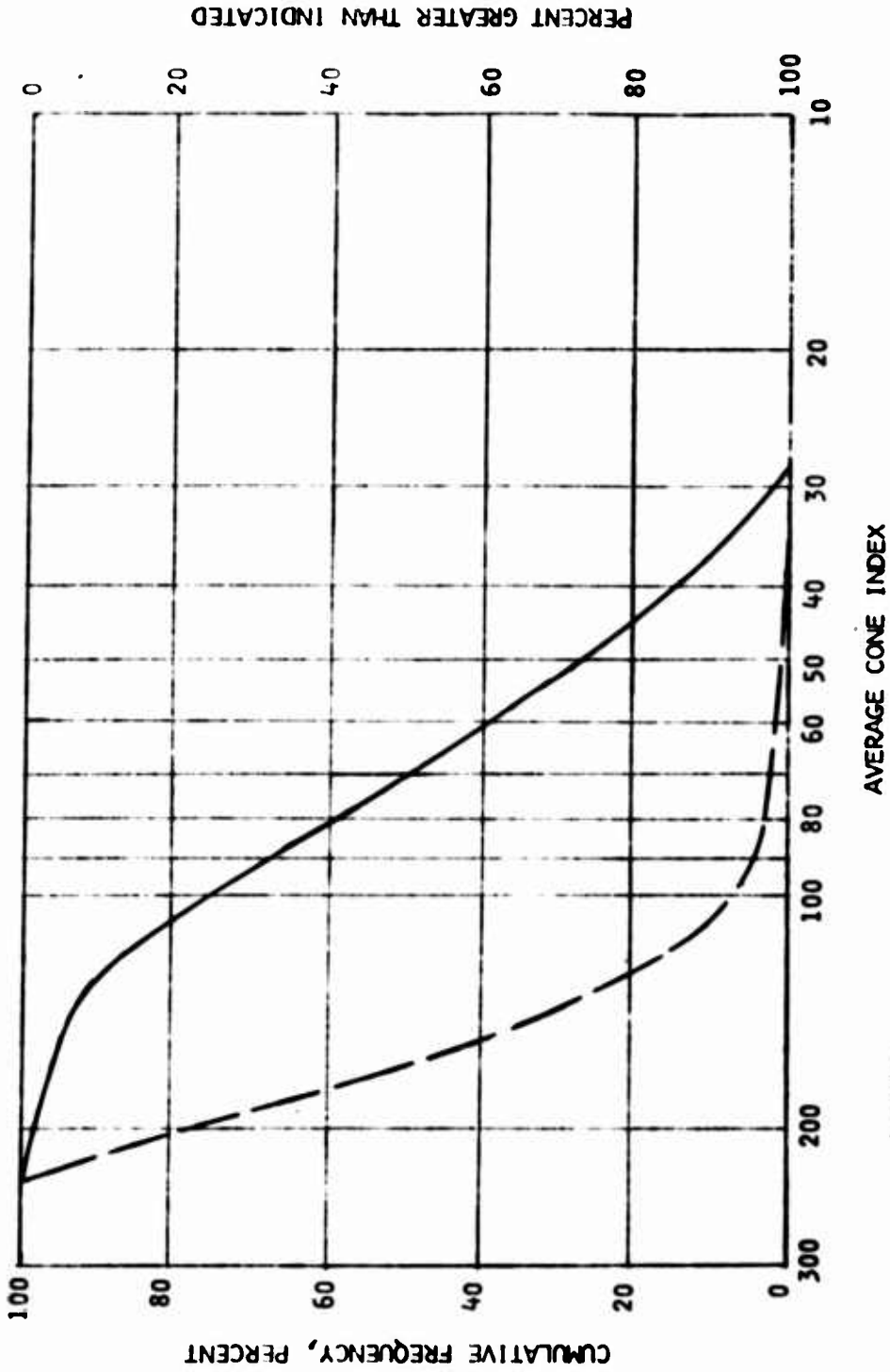

LEGEND
 — 0- to 6-in. layer
 - - 0- to 12-in. layer
 NOTE: Dry-to-moist sand

Figure 4. Distribution of cone index, quartz beach foreshore

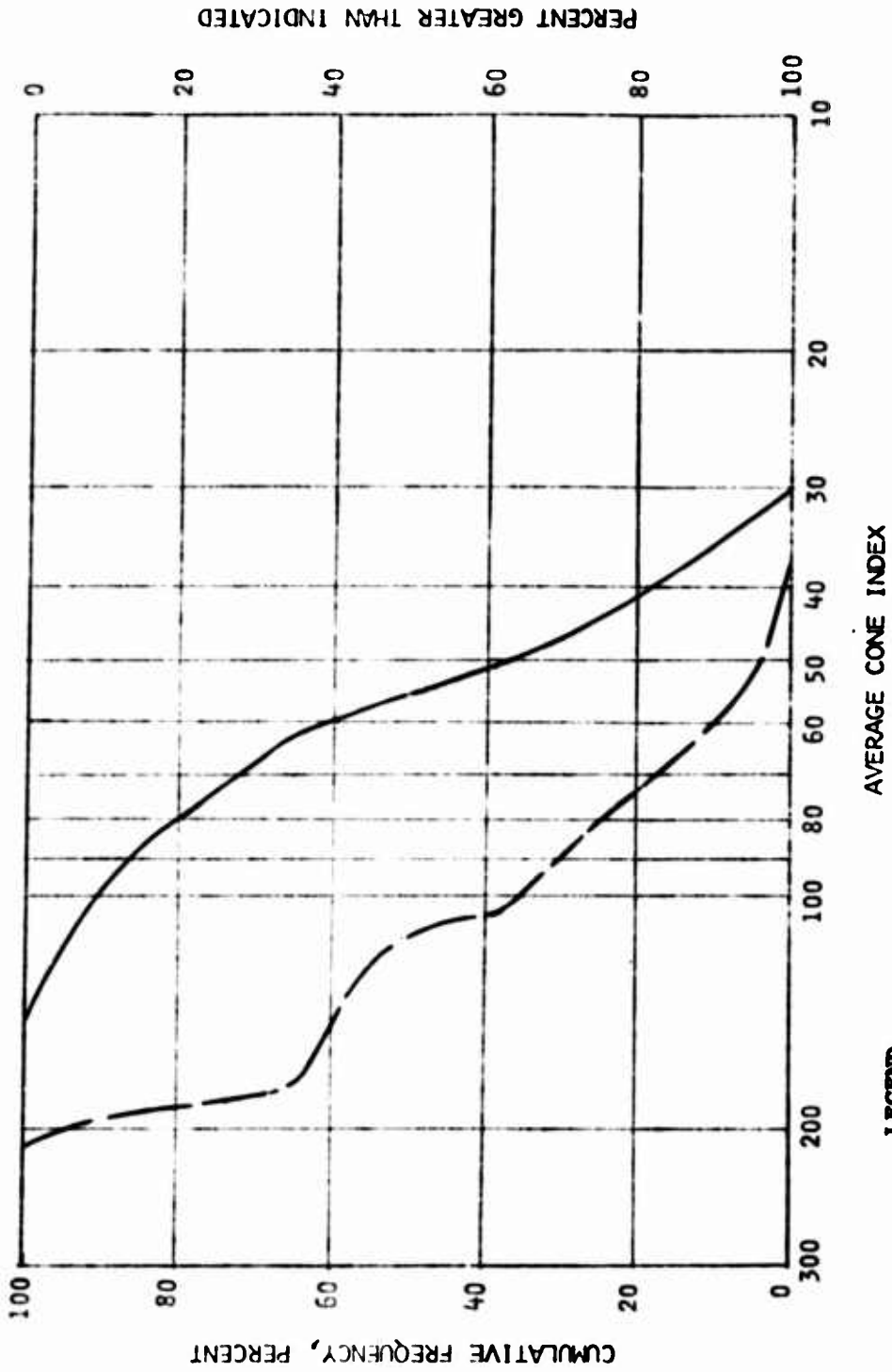

LEGEND
 — 0- to 6-in. layer
 - - 0- to 12-in. layer
 NOTE: Dry-to-moist sand

Figure 5. Distribution of cone index, coral beach foreshore

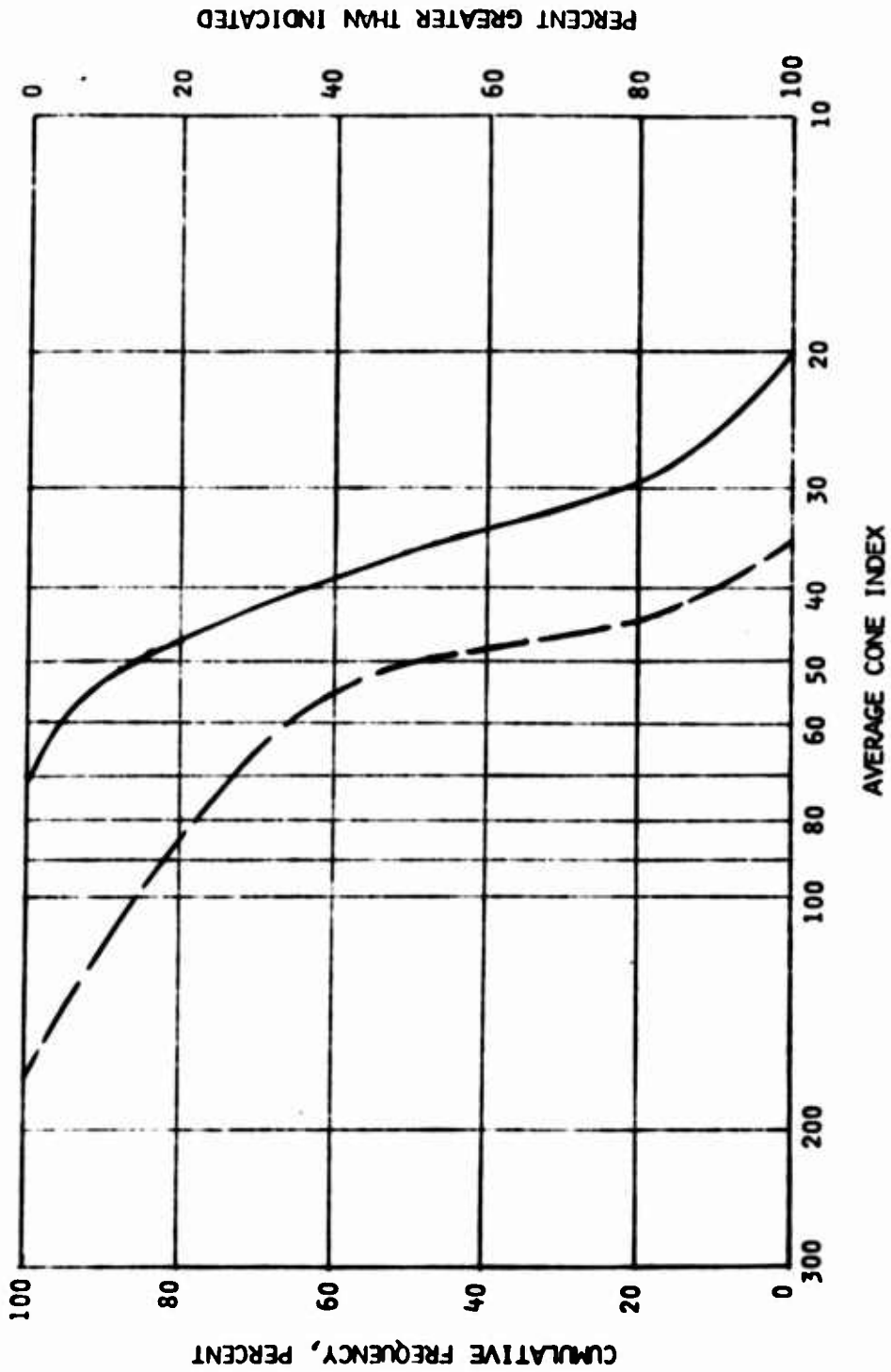

LEGEND
 — 0- to 6-in. layer
 - - 0- to 12-in. layer
 NOTE: Dry-to-moist sand

Figure 6. Distribution of cone index, volcanic beach foreshore

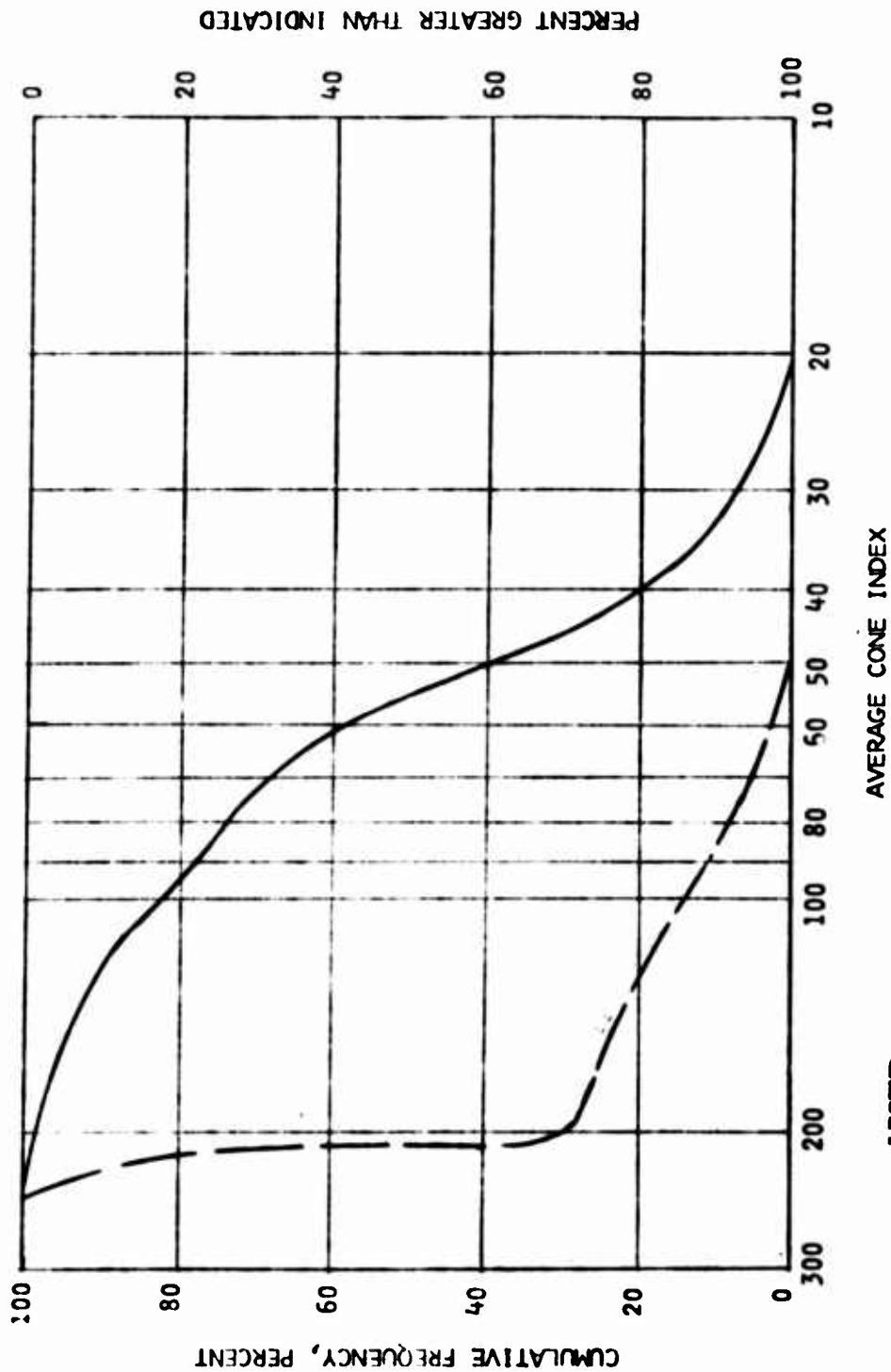
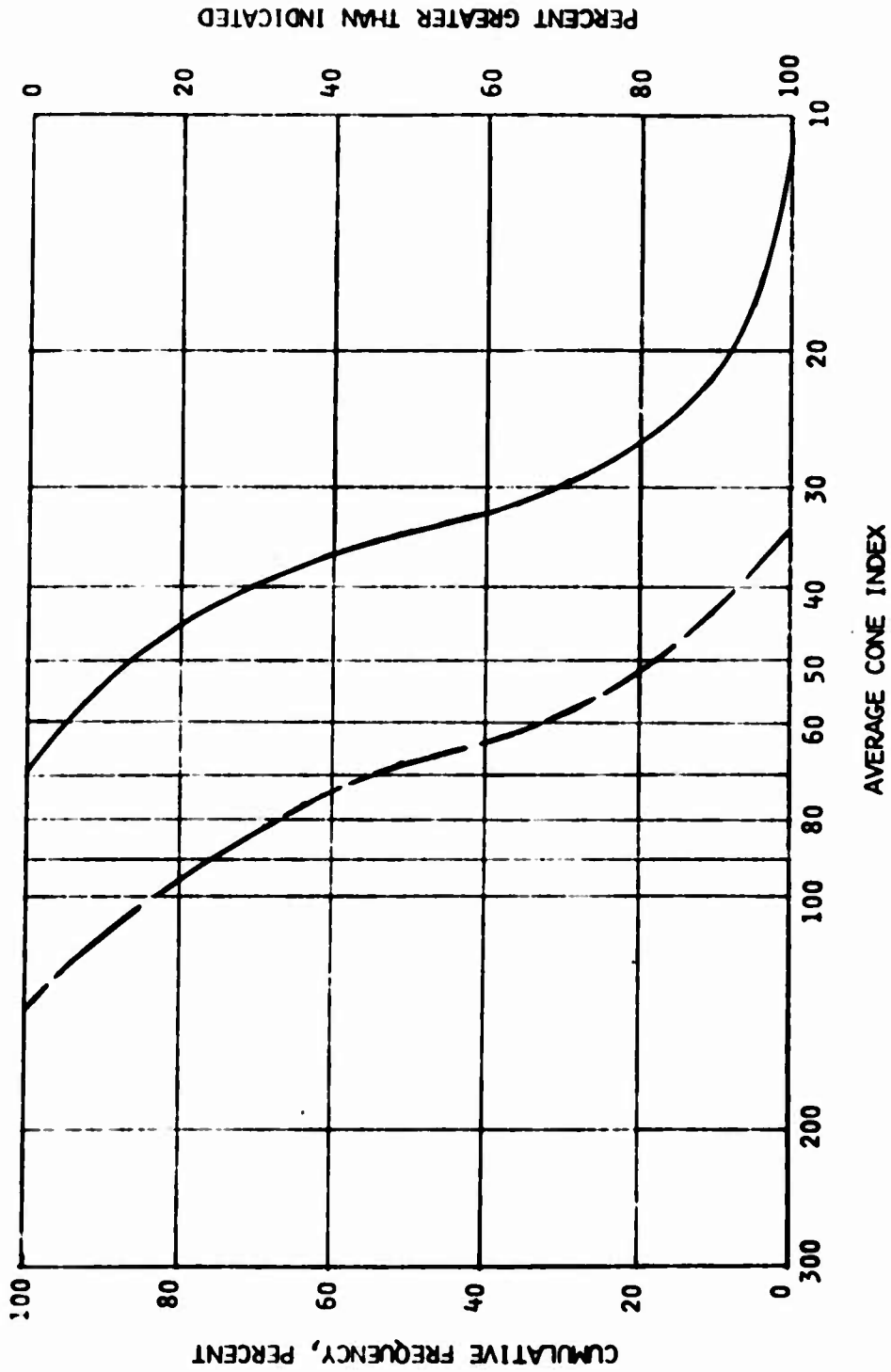

Figure 7. Distribution of cone index, quartz beach backshore



LEGEND
 — 0- to 6-in. layer
 - - 0- to 12-in. layer
 NOTE: Dry-to-moist sand

Figure 8. Distribution of cone index, coral beach backshore

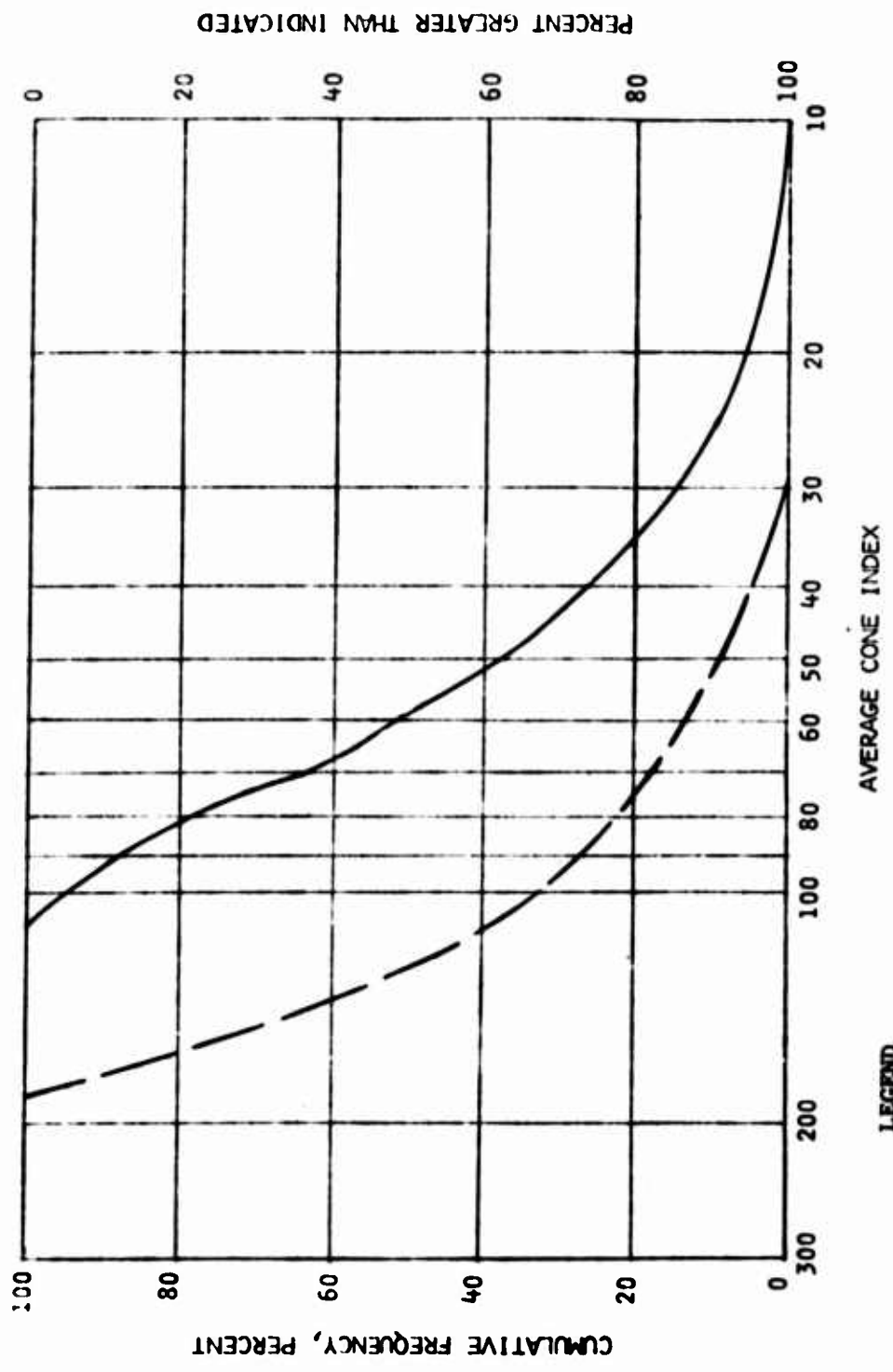
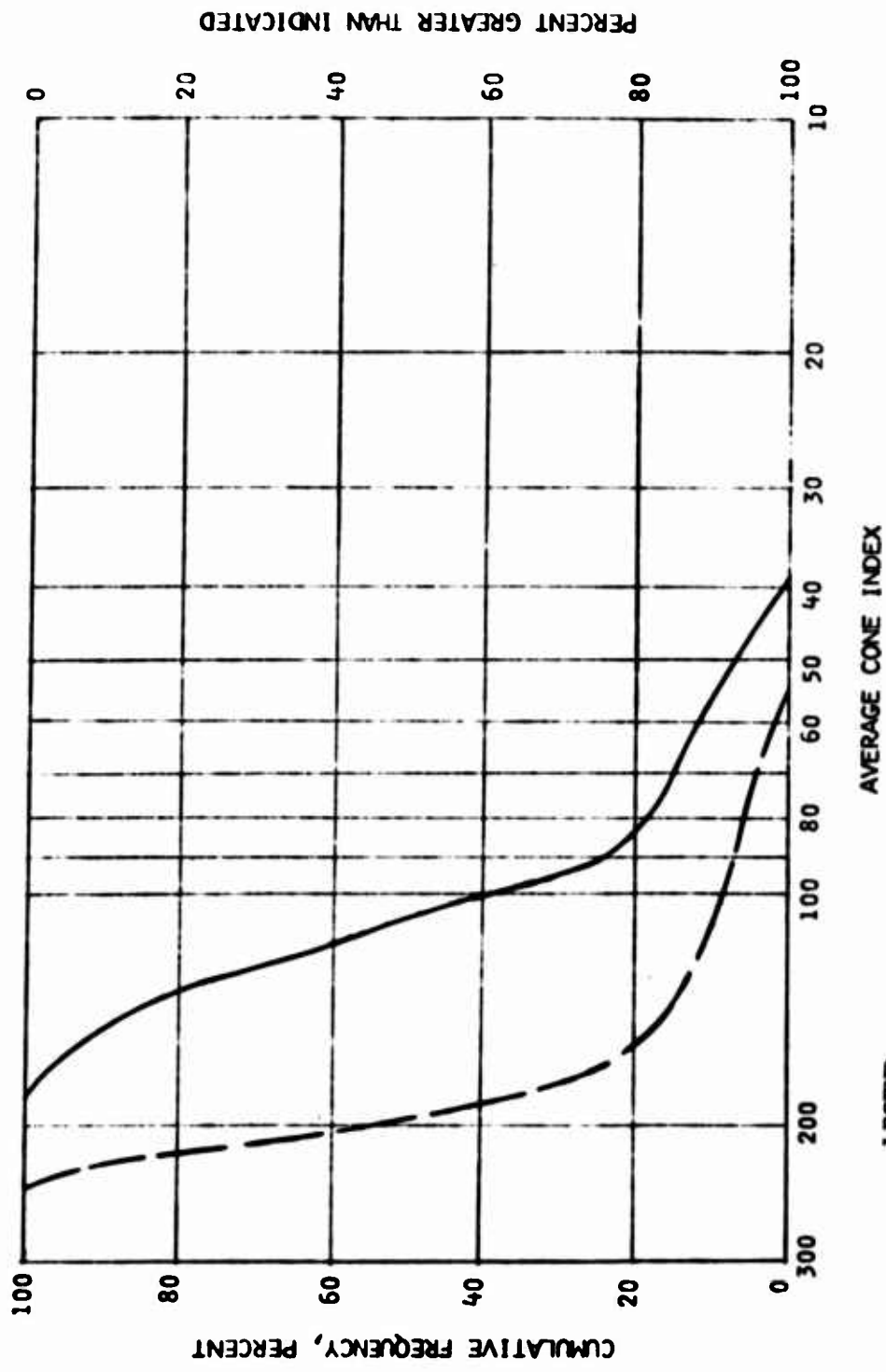

Figure 9. Distribution of cone index, volcanic beach backshore

LEGEND

- 0- to 6-in. layer
 - - - 0- to 12-in. layer
- NOTE: Dry-to-moist sand



LEGEND
 — 0- to 6-in. layer
 - - 0- to 12-in. layer
 NOTE: Dry-to-moist sand

Figure 10. Distribution of cone index, quartz beach forward dune apron

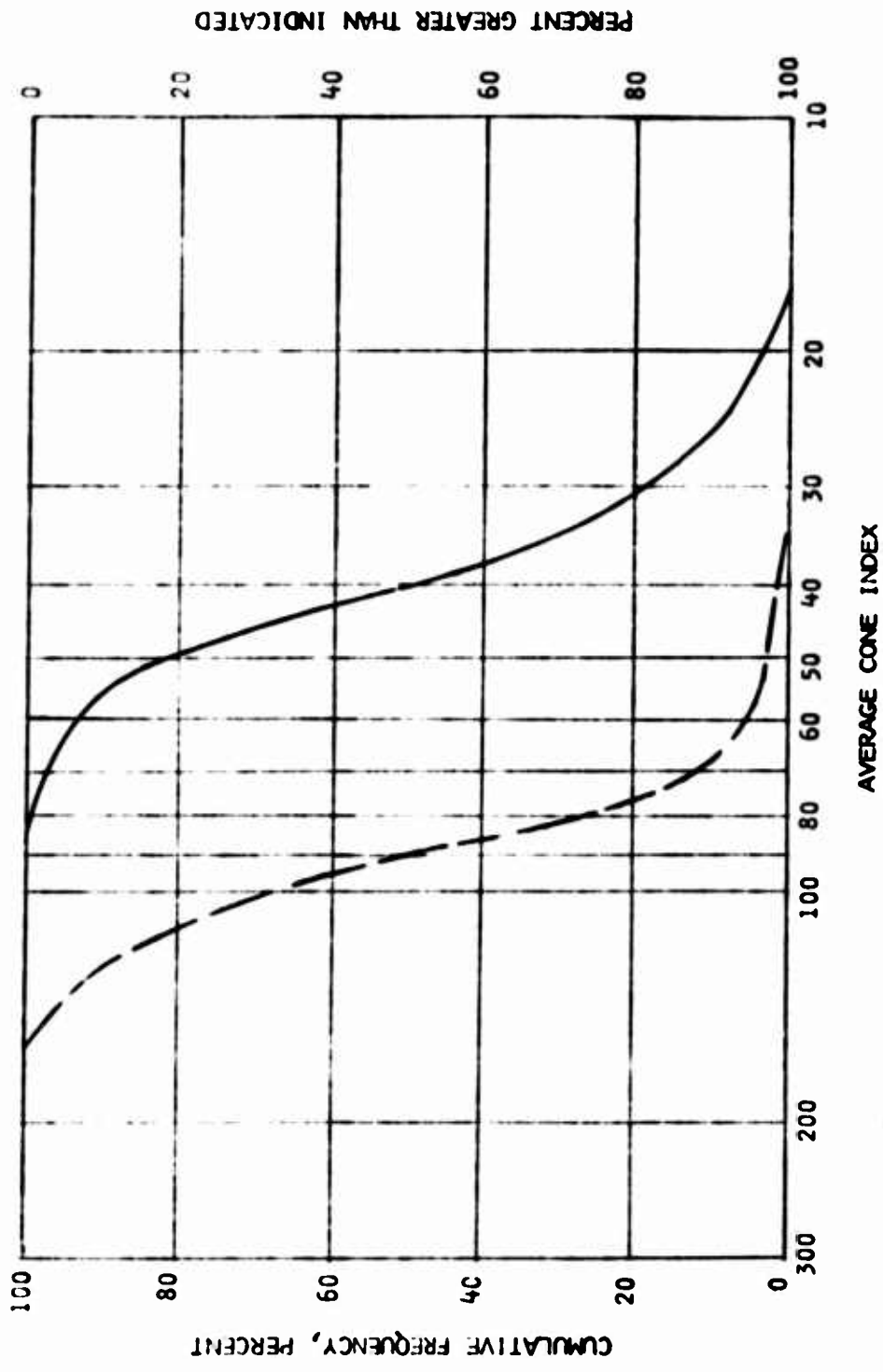

LEGEND
 — 0- to 6-in. layer
 - - 0- to 12 in. layer
 ... NOTE: Dry-to-moist sand

Figure 11. Distribution of cone index, coral beach forward dune apron

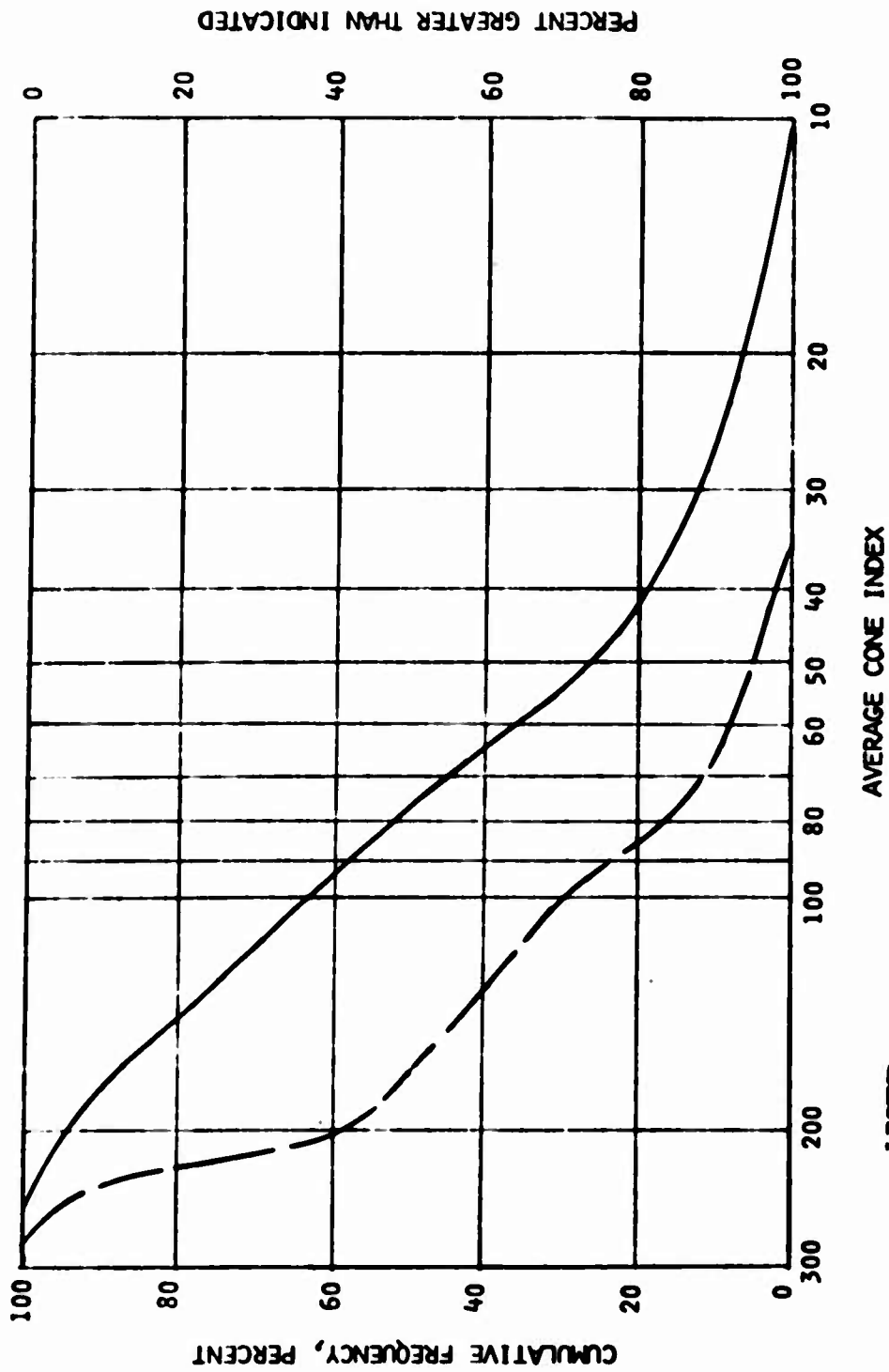

LEGEND
 — 0- to 6-in. layer
 - - 0- to 12-in. layer
 NOTE: Dry-to-moist sand

Figure 12. Distribution of cone index, quartz beach and dune areas

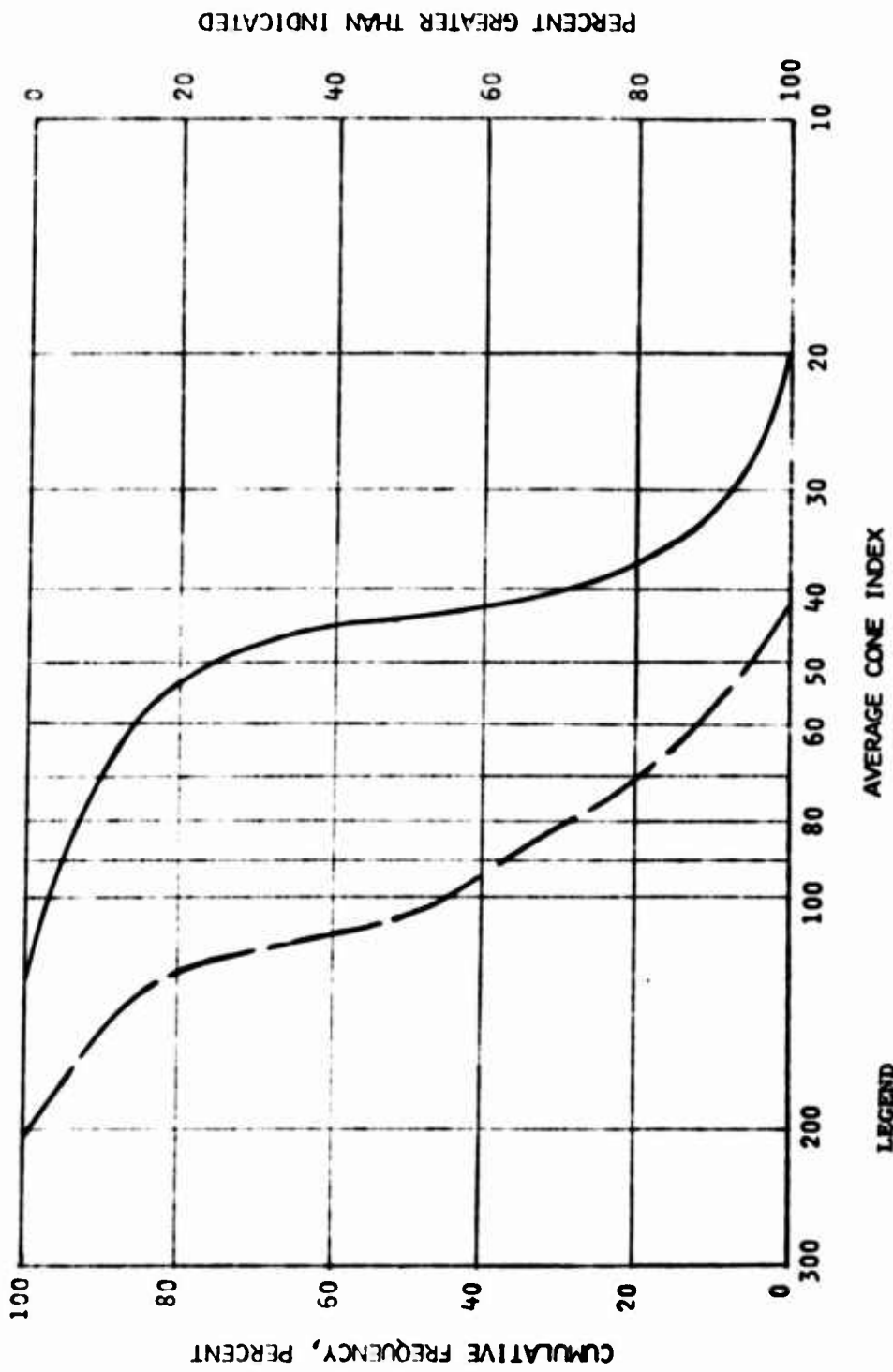

LEGEND
 — 0- to 6-in. layer
 - - 0- to 12-in. layer
 NOTE: Dry-to-moist sand

Figure 13. Distribution of cone index, coral beach dune areas

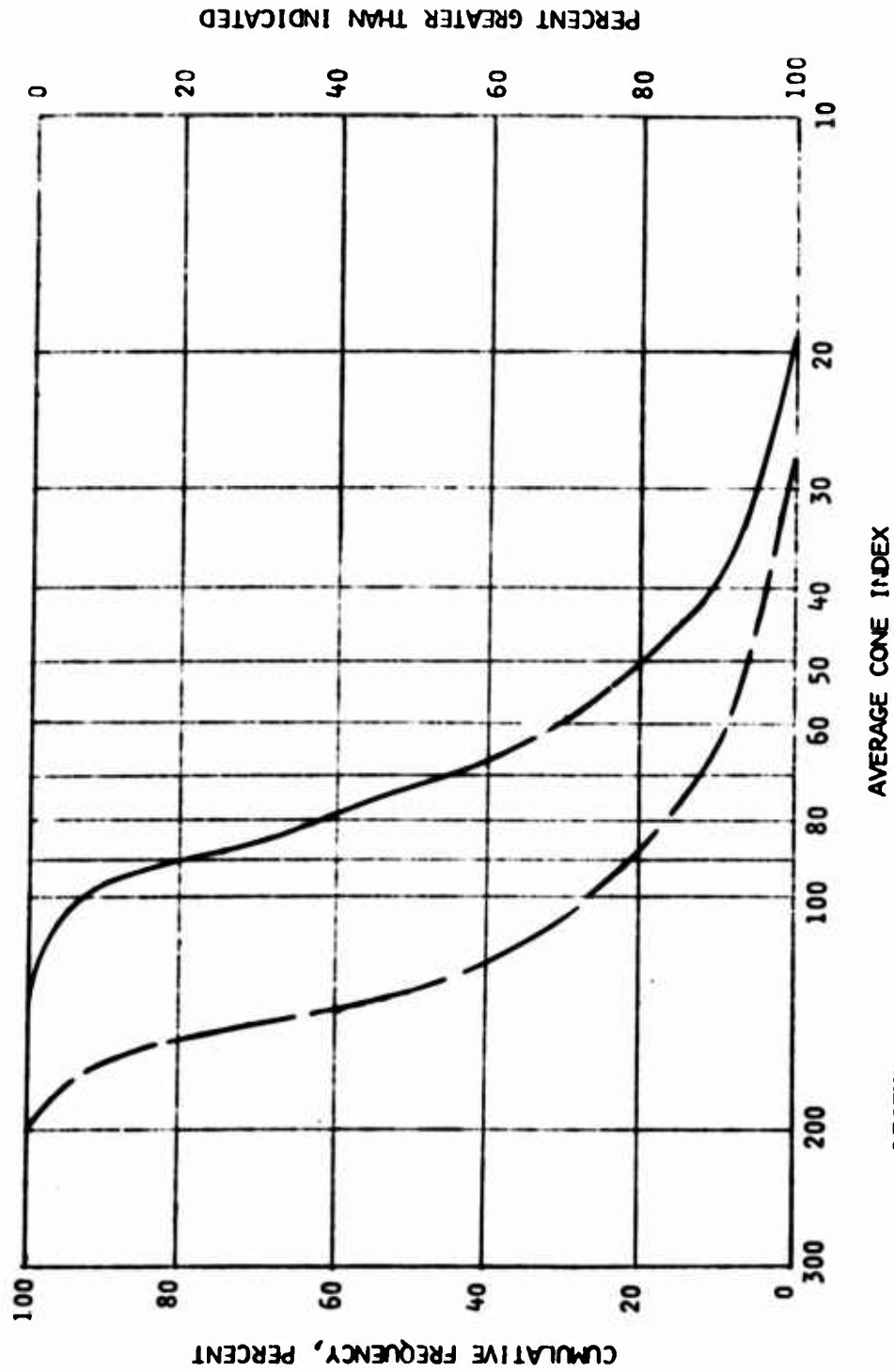

LEGEND
 — 0- to 6-in. layer
 - - 0- to 12-in. layer
 NOTE: Dry-to-moist sand

Figure 14. Distribution of cone index, quartz desert dune areas

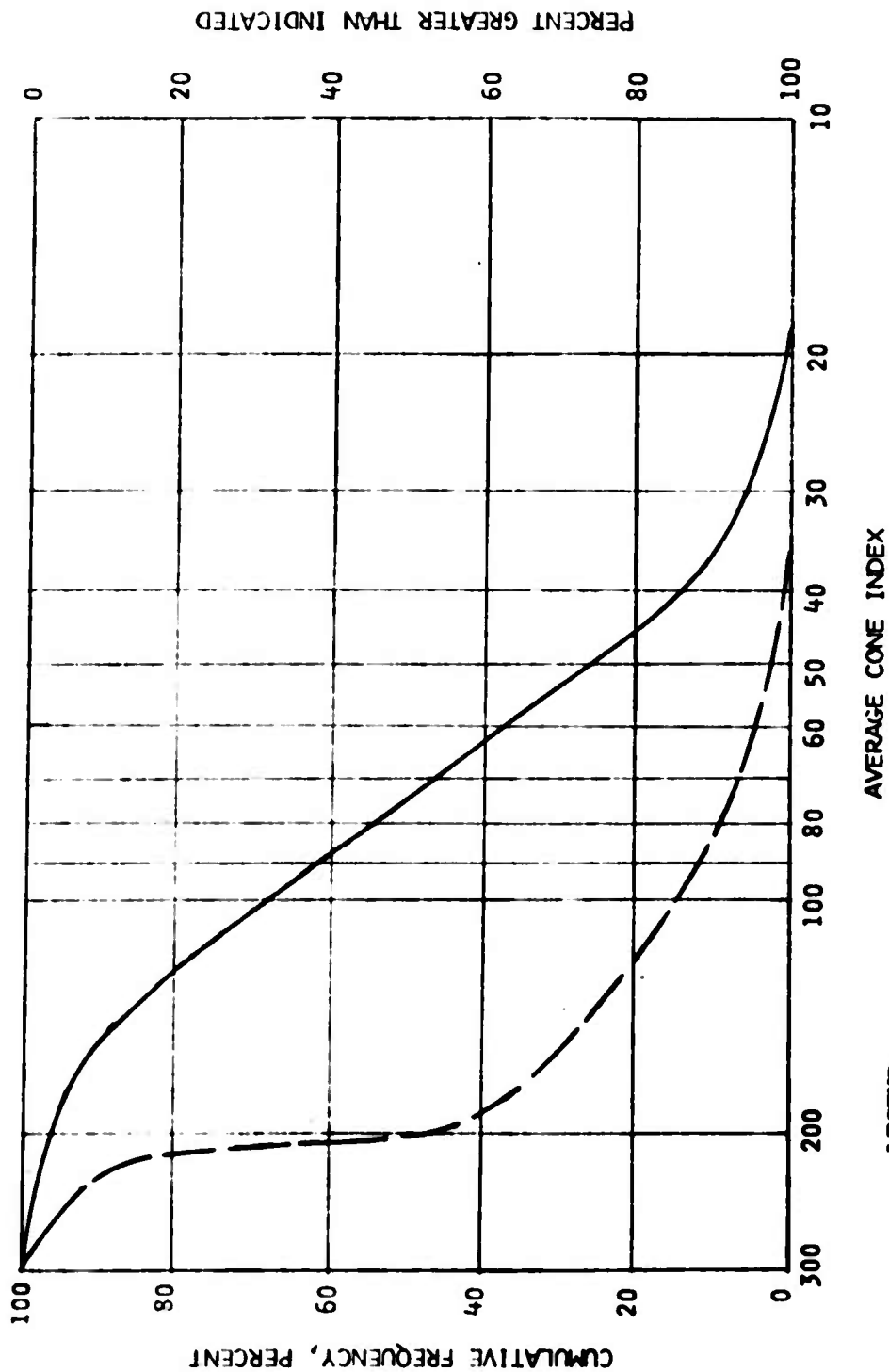
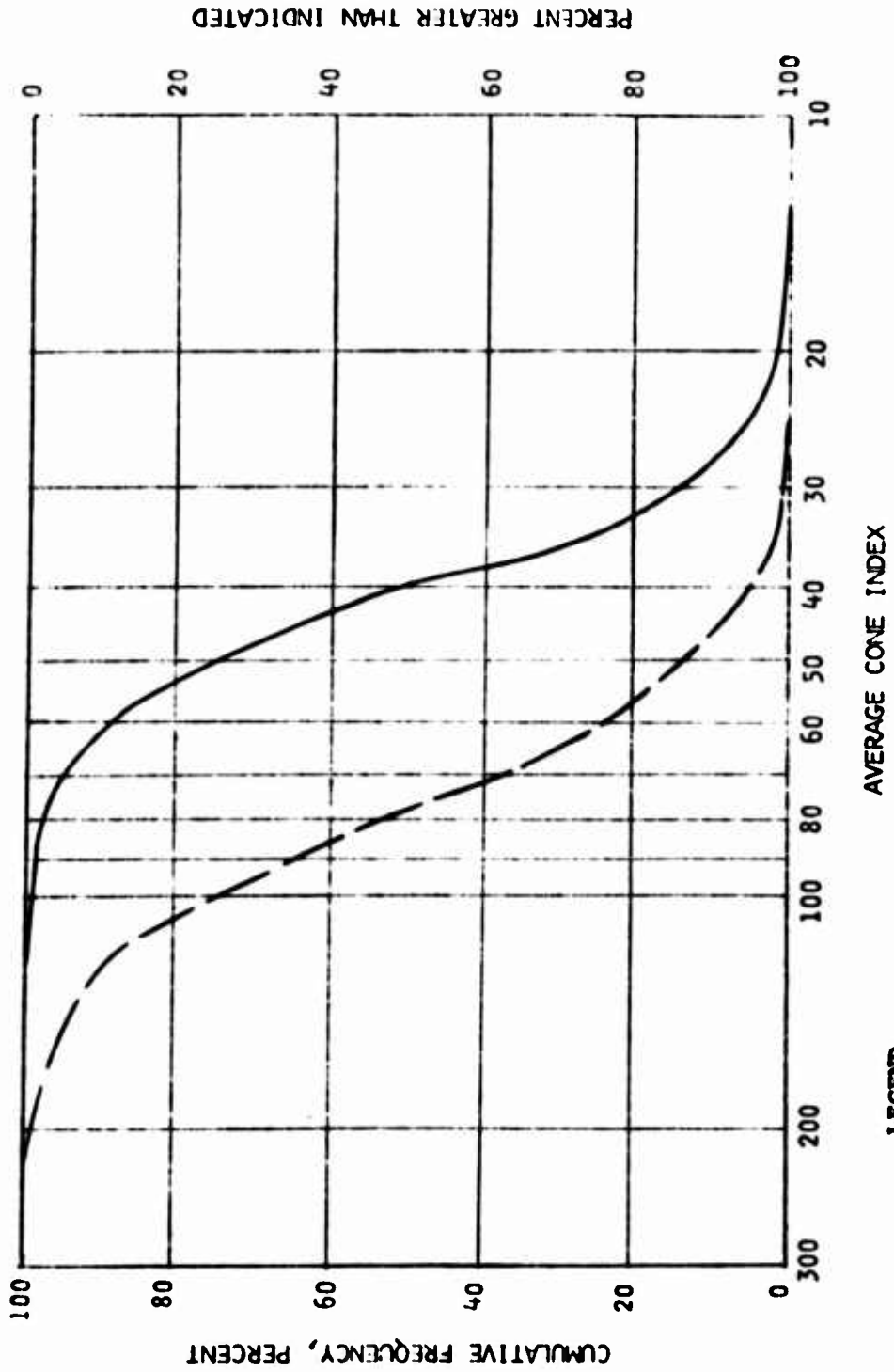

Figure 15. Distribution of cone index, all quartz beaches and beach areas



LEGEND
 — 0- to 6-in. layer
 - - 0- to 12-in. layer
 NOTE: Dry-to-moist sand

Figure 16. Distribution of cone index, all coral beaches and beach areas

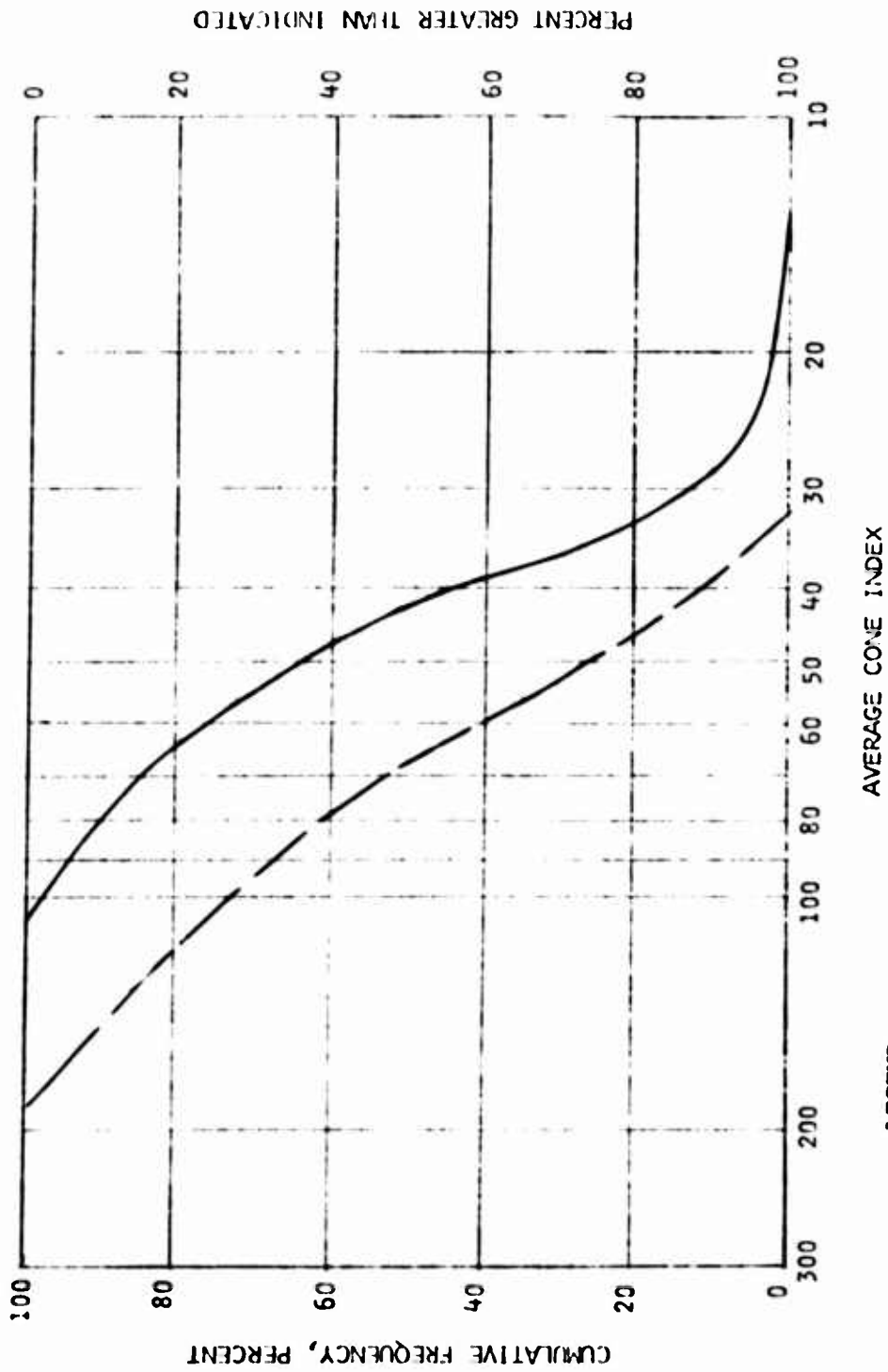

Figure 17. Distribution of cone index, all volcanic and beach areas

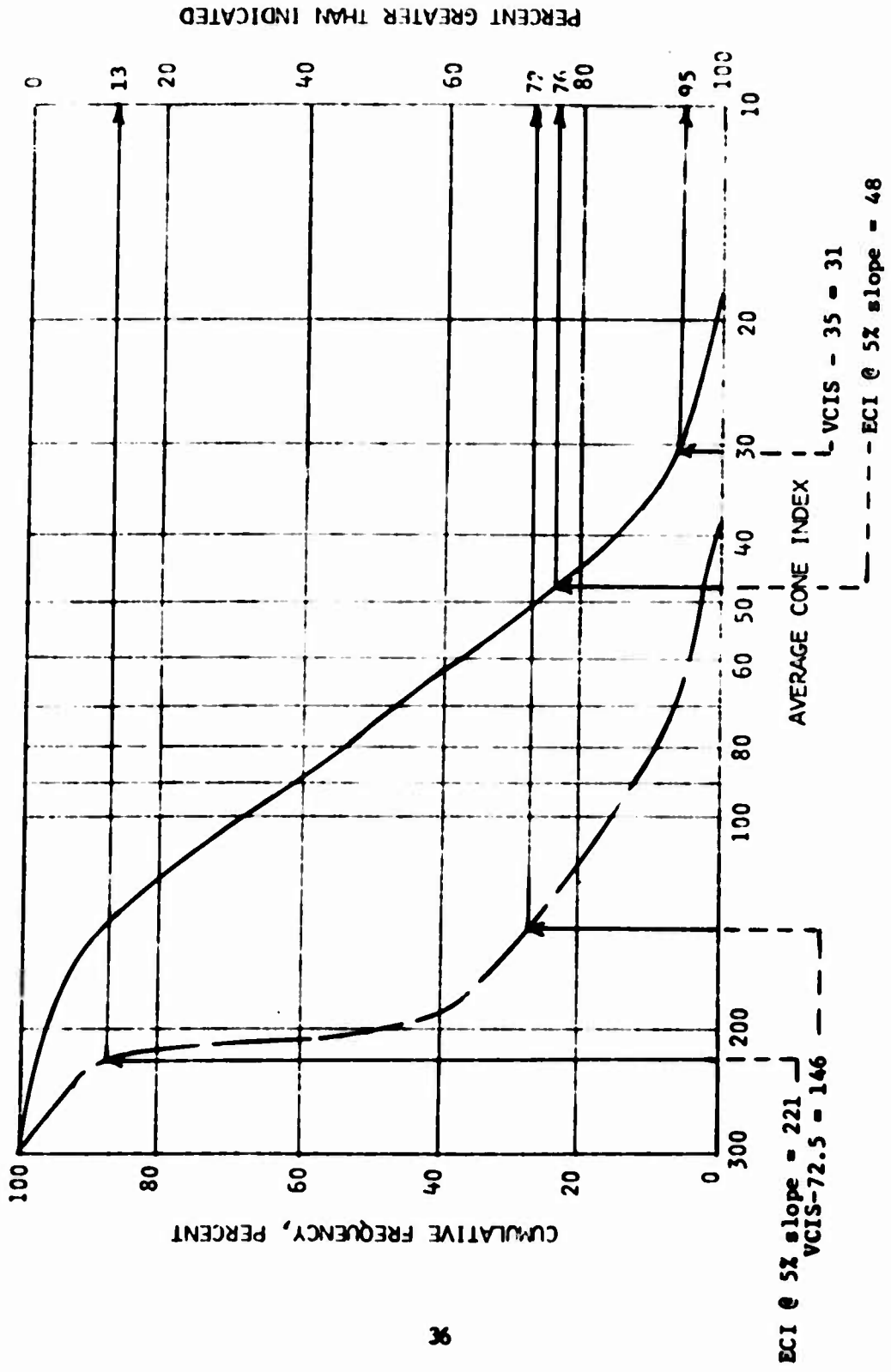

Figure 18. Performance estimations on quartz beaches, CAT 824

to travel on level sand at tire inflation pressures of 35 and 72.5 psi, respectively. Figure 18, reproducing Figure 15 for illustration here, was entered on the cone index axis at values of 31 and 146, and the ordinate of percentage of occurrence of strengths greater than indicated is read at 95 and 72 percent, respectively. Thus, the vehicle can travel on 95 or 72 percent of the level portions of the beaches measured, depending upon the inflation pressure used.

26. To account for slopes, the performance curves in Figures 3 and 2 can be converted to a maximum slope negotiable-slope index graph, as shown in Figure 19, by setting VCIS-35 and -72.5 to zero and reading the curves for increased cone index requirements (VCIS-P) when a specific slope is considered. For example, in Figure 18 if a 5 percent slope is encountered, then the effective cone index (ECI) becomes $48(31+17)$ and $221(146 + 75)$ for 35- and 72.5-psi inflation pressures and the percentage of the quartz beaches negotiable reduces to 76 and 13 percent, respectively, for the two inflation pressures.

27. Table 6 lists performance estimates for selected slopes on the beaches, beach areas, and deserts shown in Figures 4-17.

Areal distribution of beach and desert sands

28. To determine the areal extent of beach and desert sands that have been measured for trafficability purposes (Table 3), a desk study was performed and results are discussed in the following paragraphs.

29. Distribution of beach areas by continents. Information on the length of coastal beach sands on a continental basis was obtained from references 10 and 11. The percentages of total coastal lengths covered by sand or other coarse-grained particle size materials are tabulated below.

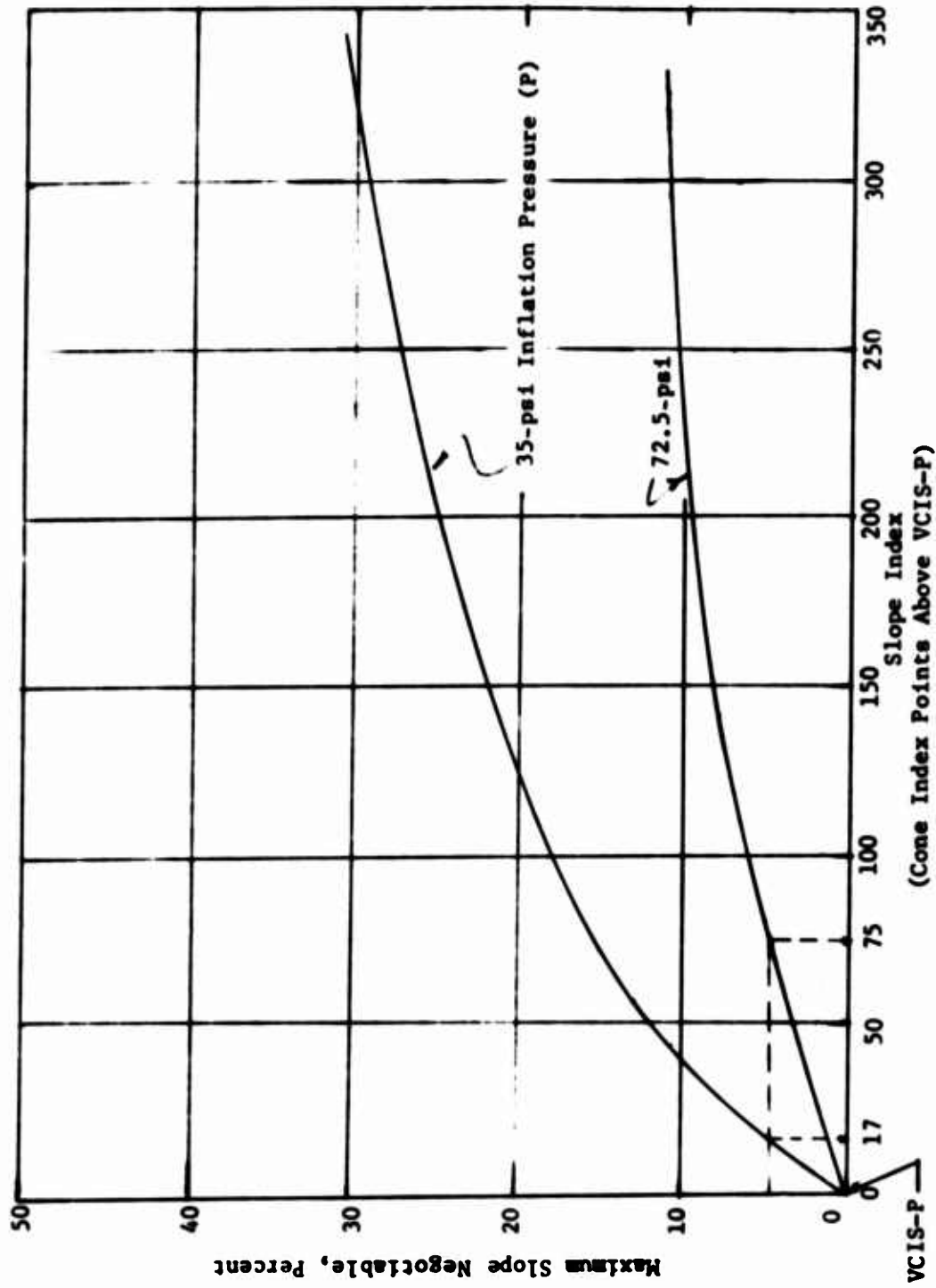

Figure 19. Maximum slope negotiable versus slope index

<u>Continent</u>	<u>Total Coastal Length, Miles*</u>	<u>Sand Beaches**</u>	
		<u>Cumulative Length, Miles</u>	<u>Percentage of Total Coastal Length</u>
Africa	18,950	4,040	21
Asia	43,870	3,480	8
Australia	12,120	1,370	11
Europe	23,120	2,730	12
N. America	46,915	6,460	14
S. America	17,830	1,600	9
TOTAL	162,805	19,680	12

* Excluding islands.

** Excluding islands but including barrier beaches, barrier islands, and coastal dunes.

Total coastal lengths were obtained from reference 10; the cumulative length of beaches from the world map in reference 11 at a scale of 1:25,000,000. Time did not permit the determination of sand beaches that were bordered on the inland side by cliffs or marshy/swampy areas that would limit over-the-beach operations. Nor were time and information available to determine the probable distribution of sand strengths (cone index) or slopes on a continental basis.

30. Distribution of beach areas in contiguous U. S. Information on distribution of beaches in the contiguous U. S. was obtained from a series of National Shoreline Studies conducted by the Corps of Engineers (references 12-17). These studies contain detailed information by states on the physical characteristics of the ocean coastlines as they pertain mainly to beach erosion. For the study herein, the information has been summarized, and only the portions pertaining to ocean coastline lengths are presented; this includes portions of bays and estuaries directly exposed to ocean wave action. The total coastal length in most cases includes the shorelines of offshore islands. The following tabulation shows, by states, the total length of ocean coastline and the length and percentage of the total that are sand beaches.

State	Total Coastal Length, Miles	Sand Beaches	
		Cumulative Length, Miles	Percentage of Total Coastal Length
Maine	2500	60	2
New Hampshire	15	12	80
Massachusetts	207	178	86
Rhode Island	190	140	74
Connecticut*	270	145	54
New York	136	135	99
New Jersey	124	124	100
Delaware	25	25	100
Maryland	31	31	100
Virginia	90	82	91
N. Carolina	320	320	100
S. Carolina	187	187	100
Georgia	92	87	95
Florida	1266	781	62
Alabama	46	46	100
Mississippi	33	27	82
Louisiana	810	365	45
Texas	373	361	97
California	1342	623	46
Oregon	352	256	73
Washington	301	236	78
U. S.	8710	4221	48

* The National Shoreline Study does not consider the Connecticut shoreline as exposed to ocean wave action because of protection by Long Island but for the study herein it has been included.

31. Desert sand areas. Information on desert sand areas was obtained mainly from references 18 and 19. The term "desert" is commonly applied to regions characterized by meager precipitation, scanty vegetation, and limited human use. Deserts are highly varied in area, altitude, landforms, geology, and other physical features. Surface materials include base bedrock, plains of gravel and boulders, and vast tracts of shifting sand. Wind-blown sands, commonly thought to be typical of deserts, actually make up only a small percentage of the total desert

area in a given location. The following tabulation gives, by continents, the percentage of desert areas that are sands.

<u>Continent</u>	<u>Sand Desert, Percent of Total Land Area</u>
Asia (includes Middle East)	6
Africa	10
Australia	15
North America	<1
South America	<1
Europe	<1

32. In Africa, the Sahara Desert has about 300,000 sq miles of active dunes. One third of Saudi Arabia, approximately 400,000 sq miles is covered with active dunes. Vast tracts of sandy desert exist in central Asia, extending from Israel and Syria eastward through Iran, western Pakistan into Saudi Arabia, and northeastward into Mongolia.

33. Of possible importance from a sand trafficability standpoint are other active and stable sand regions not found in true deserts. For example, stable sand dunes are found in Nebraska and nearby states that cover approximately 18,000 sq miles. Sand dunes that are stable are usually sparsely covered with vegetation, and surface disturbance, such as vehicular traffic, could easily cause the surface to become unstable and react to traffic in a manner similar to that on beach and loose desert sands. The following tabulation shows, by continents, the percentage of total areas that are covered by active and stable sand regions (including sand deserts).

<u>Continent</u>	<u>Total Land Area, Square Miles*</u>	<u>Active and Stable Sand Regions Percentage of Total Land Area</u>
Asia (includes Middle East)	17,035,000	15
Africa	11,635,000	19
Australia	2,974,500	31
North America	9,435,000	11
South America	6,860,000	6
Europe	<u>3,850,000</u>	<u><1</u>
Total	51,789,500	Average 14

* Total land areas vary slightly depending upon source of information

Summary Discussion

34. Only one vehicle, the CAT 824, was considered in the analysis of vehicle performance on natural sand beaches and deserts. Since tire inflation pressure is the most important vehicle characteristic affecting performance, two extremes of inflation pressures were used to illustrate this effect. An average inflation pressure of 72.5 psi (90 psi in the front tires and 55 psi in the rear tires) was the highest pressure used and is an average of the manufacturer's recommended inflation pressures for the vehicle operating at maximum load. The lowest inflation pressure that allowed certain operational capabilities in sand was 35 psi, a value attainable by using radial-ply tires. The minimum cone indexes that will permit travel over level sand were determined by experimental results to be 146 for 72.5-psi inflation pressure and 31 for 35-psi inflation pressure.

35. From data available, the frequency of occurrence of cone index values was determined for beach and desert sands. The data did not, however, provide for the determination of frequency of occurrence of slopes (another important factor affecting performance).

36. By using the vehicle performance-cone index curves and the curves of frequency of occurrence of cone index ranges on related sands, the performance of the CAT 824 was estimated for certain surface

slope values. For example, at 35-psi inflation pressure on quartz beaches, the vehicle can negotiate 95 percent of the level areas. If, however, a slope of 5 percent is encountered, the area negotiable is reduced from 95 to 76 percent. At the high inflation pressure (72.5 psi) for the same quartz beaches and for level and 5 percent sloping surfaces, the negotiable areas are 72 and 13 percent, respectively.

37. The total coastal length of all continents is estimated to be 162,805 miles; the cumulative length of sand beaches was determined to be 19,680 miles, or 12 percent of total length. The 12 percent value may not seem significant, but it is well known that in most areas, shore operations are conducted on sand beaches. Assuming the 19,680 miles of sand beaches as 100 percent of possible operating areas and that all the beaches are quartz sand (coral and volcanic sands are found mainly on Pacific islands not included in this distribution), then if slopes greater than 5 percent are not encountered, the amount of operational beach distance for the CAT 824 is 14,957 ($19,680 \times .76$) miles when operating at 35-psi inflation pressure and 2558 ($19,680 \times .13$) miles when operating at 72.5-psi inflation pressure. A similar analysis can be made for the contiguous United States where 48 percent (4221 miles) of the shoreline are sand beaches. Again assuming all beaches are quartz sand, if slopes greater than 5 percent are not encountered, the amount of operational beach distance is 3208 ($4221 \times .76$) miles when operating at 35-psi inflation pressure and 549 ($4221 \times .13$) miles when operating at 72.5-psi inflation pressure.

38. On a worldwide basis, of the total land mass, approximately 14 percent or 7,250,530 ($51,789,500 \times .14$) square miles are sand regions (both active and stable). Assuming that operations in these sand regions would require the CAT 824 to negotiate slopes no greater than 10 percent (upped from 5 percent in the previous analysis since operations on inland sand region are likely to encounter steeper slopes than operations on beaches), then of the 7,250,530 square miles of sand regions, the CAT 824 at 35-psi inflation pressures can negotiate 4,060,297 ($7,250,530 \times .56$) square miles and at 72.5-psi inflation pressures none of the sand regions could be negotiated.

**PART III: STABILIZATION OF BEACH SANDS FOR OPERATION OF
CONTAINER HANDLING EQUIPMENT**

39. A wheeled vehicle engaged in transporting containers from and to landing craft at beach sites must satisfactorily negotiate four different sections of ground:

- a. The submerged sections of beach between the landing craft and the shore.
- b. The moist section of the beach that is covered by water at high tide or subject to waves' uprush (foreshore).
- c. The dry section of the beach above the limit of uprush at high tide (backshore).
- d. The dune area, which may be sand dunes, a cliff, a bog, etc.

40. The trafficability of a soil depends on three principal factors:

- a. The soil must have sufficient bearing capacity to support the vehicle.
- b. The soil must have sufficient tractive capacity to develop the resistance between the soil and a vehicle's tires or tracks required to provide forward thrust.
- c. The rolling resistance due to the interaction of soil and a vehicle must not be greater than the forward thrust that the vehicle's power train can develop.

41. Immobilization might well result from bearing failure of the sand beneath the wheels, cumulative rutting, or liquefaction or flowing of the saturated sand beneath a tire operating in or about the surf line. Primarily then, the in situ strength characterization of a particular beach sand and the extent and type of the anticipated operation provide the basic constraints of container handler mobility at beach and inland transfer points. With these constraints evaluated or judiciously estimated for a given beach site, the logical sequence is to determine whether the beach will allow a completed mission;

if not, what options are available for improving (i.e. stabilizing) the beach so that it will.

42. The purpose of this part of the report is to review various methods that might be considered in expediently and successfully improving a specific beach to permit container handling by the CAT 824. General guidelines will be discussed for evaluating those properties of in situ beach sands pertinent to over-the-beach mobility and an introduction to the various stabilization methods specifically applicable to beach sands and vehicle traffic. The intent is not to present complete beach stabilization design criteria, as in some instances the state of the art has not been sufficiently developed for this particular problem. Rather this section will serve as an introduction to beach stabilization, while attempting to identify areas for further investigation, exploitation, or evaluation.

Factors Affecting Beach Stabilization

Characteristics of beach materials

43. Although most beaches are composed of sandy materials whose composition and sizes may vary widely. The cohesionless beach materials may range in size from fine sands to larger gravels and shell fragments, they may be well graded or poorly graded, and they may consist predominantly of quartz, carbonate, or volcanic materials. Landings may also have to be made on beaches composed of fine-grained soils, such as silts and clays. When these latter types of soil have a relatively high water content, they become soft and plastic and are termed "muds." Mud flats present serious trafficability problems, and their characteristics are very different from those of sandy beaches. Only sandy beaches will be addressed in this report.

44. On sandy beaches, the soil consists of noncohesive, relatively coarse (diameter greater than 0.02 mm), rounded grains containing in their voids variable amounts of moisture and air. On the beach back-

shore the sand is practically dry with the water content increasing gradually as the sea is approached, becoming saturated near the limit of uprush. The water in the voids has the same average composition as the sea water.

Strength properties of sands

45. General relations. The strength of clean sand is primarily a function of internal particle friction which is defined as the angle of internal friction, ϕ . The degree of compaction or void ratio, degree of uniformity of the sand, and the angularity of the grains effect the magnitude of ϕ and the value of ϕ decreases with increasing uniformity of the sand and increases with increasing angularity of the grains. For a given sand, the greater its density (the more compact the sand), the higher is the angle of internal friction. The range in ϕ values of a sand from a very loose condition to a very dense condition may be as much as 10 deg.

46. The bearing capacity of sand increases rapidly with increasing values of the angle of internal friction, ϕ . A small increase in the sand's density results in an increase in the angle of internal friction and a considerable increase in bearing capacity. The bearing capacity also is considerably increased if the loaded area is below the adjacent ground surface. This increase, due to the depth of the loaded area, is substantially greater for sands than for saturated clays. Sands which are not trafficable by vehicles equipped with pneumatic tires operating at manufacturers recommended inflation pressures very often can be made operational by reducing the tire pressure. A reduction of the tire pressure results in the development of two interrelated events that effectively reduce the required bearing capacity. Reduction of the tire pressure results in a lower pressure applied over the loaded area and the contact area is increased, with corresponding increases in both the length and width of the loaded area. In a dry state the bearing capacity of sand depends mainly on the angle of internal friction of the soil and the size of the loaded area.

47. The bearing capacity is considerably reduced if the groundwater table is at or near the sand surface. In such a case, the

bearing capacity of soils is directly proportionate to the unit weight, the bearing capacity of a submerged sand is only about one-half that of the same sand above the water table. From the trafficability standpoint, the important effect of liquefaction is the loss of supporting capacity of soil. On a beach, the saturated sand near the water's edge may become "quick" by vehicular traffic developing pore pressure in the sand mass. As a result a vehicle will sink and become immobilized. The degree of liquefaction resulting from vehicular traffic depends on the initial density and degree of saturation of the beach material, and amount, intensity and area loaded by the vehicle traction elements.

48. In the moist state, the bearing capacity is increased by the addition of apparent cohesion of the sand mass. This apparent cohesion is due to the surface tension in menisci between sand grains, causing an increase in intergranular pressure and a corresponding increase in strength. The frictional strength due to the menisci causes the phenomenon of bulking in moist sand. A moist sand will possess some shear strength due to the menisci even though no external pressure is applied to the soil. This intergranular pressure is completely lost if the sand is dry or submerged. On a beach the apparent cohesion of the moist sand makes the moist section more trafficable than other sections of the beach. Even close to the water's edge, menisci will tend to form a few seconds after the water has receded and apparent cohesion will rapidly develop. Provided liquefaction does not occur, the moist section of the beach will have a higher bearing capacity than either the dry or submerged sections, thus irrigation of dry sand to a moist condition will improve its trafficability.

49. An idealized model. In 1935, Casagrande²⁰ introduced the "critical void ratio" concept to explain volume change of sand during shear deformations. Casagrande noted that loose sand undergoes a volume increase during drained shear; he concluded that at sufficient shear deformations, the volume decrease of a sand in a loose state and the volume increase in a dense state would tend to produce the same "critical density" or "critical void ratios" at which a sand will undergo any

amount of deformation without producing any further change in the volume or effective shear stress. Figure 20a illustrates the above relation in which the density and the deformation are plotted as functions of the stress. At large deformations, the densities (or void ratios) and shearing strengths of the loose and dense sand conditions approach a common constant value. Research by Taylor,²¹ Casagrande,²⁰ and Castro²² indicates that for fine sands under relatively low confining stresses (such as near the surface of a beach), the critical density exists within a relative density range of about 30 to 50 percent.

50. It appears reasonable to postulate that the action of a wheel traveling over a sand beach (Figure 20b) will initiate shearing stresses causing changes in the volume of the sand in the immediate vicinity of the wheel. The total wheeled vehicle system applies complex shear strains and stresses to the supporting medium. Nevertheless, a safe hypothesis is that the passing of a loaded wheel constitutes work and imparts energy to the soil. If a beach sand exists in a dense state, sufficient work delivered to the sand by the wheel would result in a relation such as that of curve A, Figure 20b. Note that as the energy input increases, the density of the sand in the vicinity of the wheel decreases toward some constant value, which implies that performance functions will also approach uniform values. Of course, energy input will depend on the vehicle's physical load, soil properties, and number of tires and power input to the running gear. However, if all variables are held constant, repetitive traffic will increase the energy input. Conversely, if a beach sand exists in a loose condition, increasing energy input (curve B, Figure 20b) will result in greater densification and enhance trafficability properties, provided the beach will support the initial traffic.

51. The above discussion assumes that the tire will not become immobile because of wheel load and dynamic motion forces exceeding the unsurfaced sand's bearing capacity. Obviously, if the strength and bearing capacity required for vehicle passage is greater than that possible for a particular beach sand at its critical density, then immobilization can be expected, regardless of the beach's existing

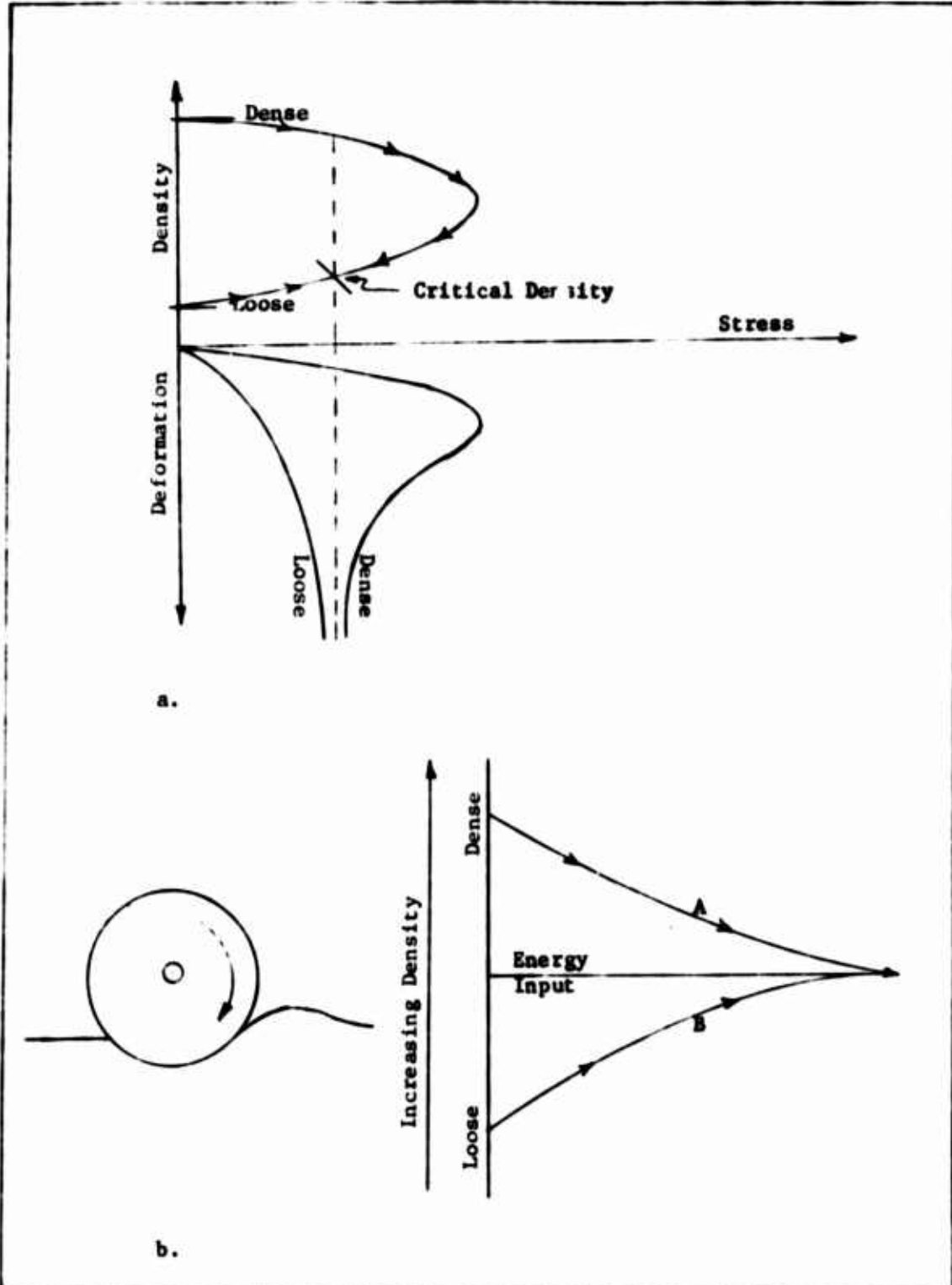

Figure 20. Critical Density

density prior to traffic. For the high loads analogous to the container carriers, this assumption is probably not valid, especially for beaches comprised of loose soil. Classical static bearing capacity of sand would indicate that an angle of internal friction, ϕ , in excess of 45 deg would be required to prevent failure. The ϕ for beach sand even in a very dense configuration would most likely not exceed 45 deg. However, bearing failure is acceptable as long as sinkage does not prevent mobility.

Prediction of Trafficability on Beach Sands

Historical prediction systems

52. Basically the problem of moving and handling containers across sand beaches is one of terra mechanics. In this country several methodologies have emerged since World War II that are directly related to the problem. On the one hand the problem was investigated from the development of pertinent soil-vehicle interactions as required for vehicle design and evaluation purposes. On the other hand the approach was to develop expedient surface cover or stabilization materials that could be used to achieve a comparatively high level of performance.

53. A selected bibliography concerning soil stabilization and surface cover material is presented in Appendix A.

54. The above methods of improving the natural environment to permit trafficability have developed from the results of different needs and objectives. For example, a flexible or rigid pavement usually implies a somewhat smooth and permanent traffic artery is desired. The thickness and composition of these surface treatments depend on not only the in situ soil strength, but also the magnitude and repeatability of the anticipated vehicle traffic. Site or route selection is governed wherever possible by high natural soil strengths. However, off-road movement is not concerned with traffic lane performance per se and, most likely, not even with the ease of ride as long as locomotion is sus-

tained within a reasonable time frame. Although the strength of the natural soil to be traversed is generally the principal concern, whether in pavement design or off-road mobility evaluation, vastly different performance criteria have emerged, primarily because of the differing objectives and constraints.

Measurement of engineering performance parameters of beach sand

55. Available beach stabilization methods and techniques require the application of a number of diversified engineering analytical procedures, each requiring specific values in characterizing soil behavior. A survey of any specific area of on- or off-road engineering will reveal that often not only do differing analytical procedures of equal rationale exist, but also each procedure may have more than one means of determining and evaluating soil behavior. Obviously, to function properly within the present state of the art, some form of reference datum would be desirable when of necessity various procedural methods and their respective data base requirements must be brought to bear on a single solution. Table 7 lists some of the principal strength parameters of soil used in various design/performance evaluation schemes.

56. General correlations among the three shear strength parameters given in Table 7 are nonexistent chiefly because the needs to be satisfied by each method vary and because values obtained from CBR and cone penetration resistance measurements are indicators of shear strength, whereas the Mohr-Coulomb (ϕ -c) relation is a verified failure criterion. CBR is an index of the bearing capacity of a soil, which is used in the design of flexible and rigid pavements. The correlation of cone penetration resistance with CBR has been found to be reasonably consistent for fine-grained plastic soils, but no consistent correlation has been obtained for granular soils. For specific soils or soil types, numerous correlations have been made between CBR and ϕ -c, and to a lesser extent between cone penetration resistance and ϕ -c. However, a definite void exists in correlating CBR, cone penetration resistance, and ϕ -c for a purely cohesionless soil such as beach sand.²³⁻²⁵ Abundant ϕ -c and cone penetration resistance data are available for a

predominantly fine quartz sand from the Yuma, Arizona, area. This sand has been used for the past 15 years at WES in laboratory mobility research programs. Unfortunately, very little information exists in terms of CBR data on Yuma sand. From a few field CBR tests obtained in the Yuma, Arizona, area²³ and some laboratory testing performed during the preparation of this report, an estimated relation between CBR and density of Yuma sand was established (Figure 21a). It is generally conceded that the most prevalent dependent property of a sand's shear strength is its density. For Yuma sand, Figures 21²⁵ and 22²⁴ illustrate relations among the various shear strength parameters discussed and Yuma sand density.

57. The WES cone penetrometer was developed more than 20 years ago as a device to obtain an index of strength of surface soils for trafficability studies and airfield construction. Basically, the instrument consists of a cone with a base diameter of 0.80 in. (2.0 cm) and an apex angle of 30 deg, attached to a shaft that is about 3 ft (1 m) long and has a smaller diameter than the cone.

58. For illustrating purposes the relation between cone penetration resistance and depth of homogeneous purely cohesive (e.g. saturated clay) and purely cohesionless (clean beach sand) soils are shown in Figures 23a and 23b. Cone penetration of a saturated cohesive clay will mobilize the soil's undrained shear strength, and then achieve constant value independent of applied stresses as shown in Figure 23a. Hence, after surface effects have been eliminated, the relation between cone penetration resistance and depth is a unique value, as illustrated in Figure 23b.

59. The available shear strength of a cohesionless soil is directly dependent on the applied stress (Figure 23c); therefore, constantly increasing forces must be applied to a cone penetrometer as it moves vertically through a sand medium (Figure 23d). This increased force is necessary to mobilize the sand's shearing resistance attributed to increase applied stress from the weight of the soil's overburden.

60. At WES, cone penetration resistance in sand is described in two ways: first, penetration resistance gradient G , defined as the gradient (or slope) of the curve of penetration resistance versus depth; and secondly, the average of penetration resistance q_c developed over

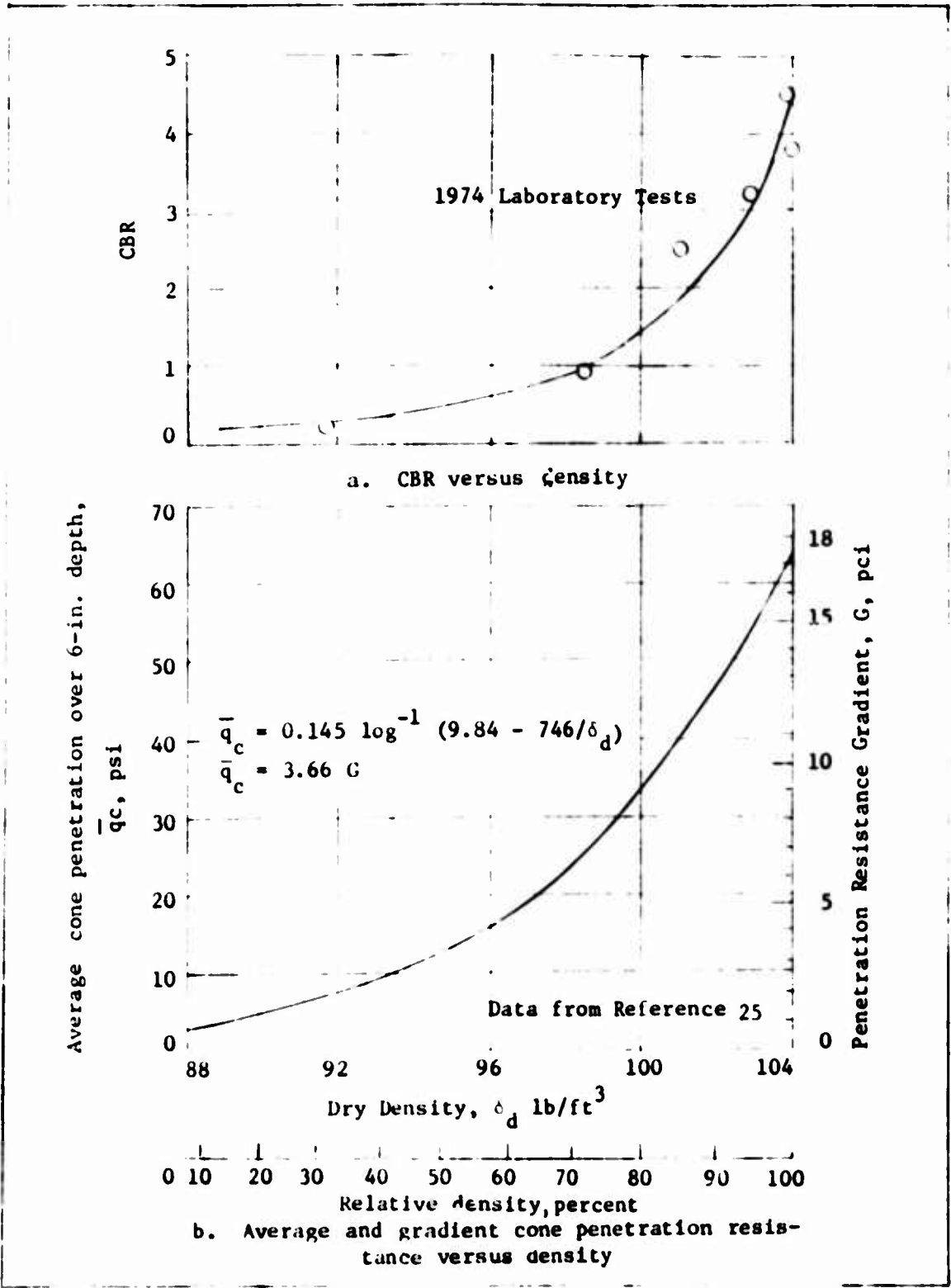

Figure 21. Strength-density relations of Yuma sand

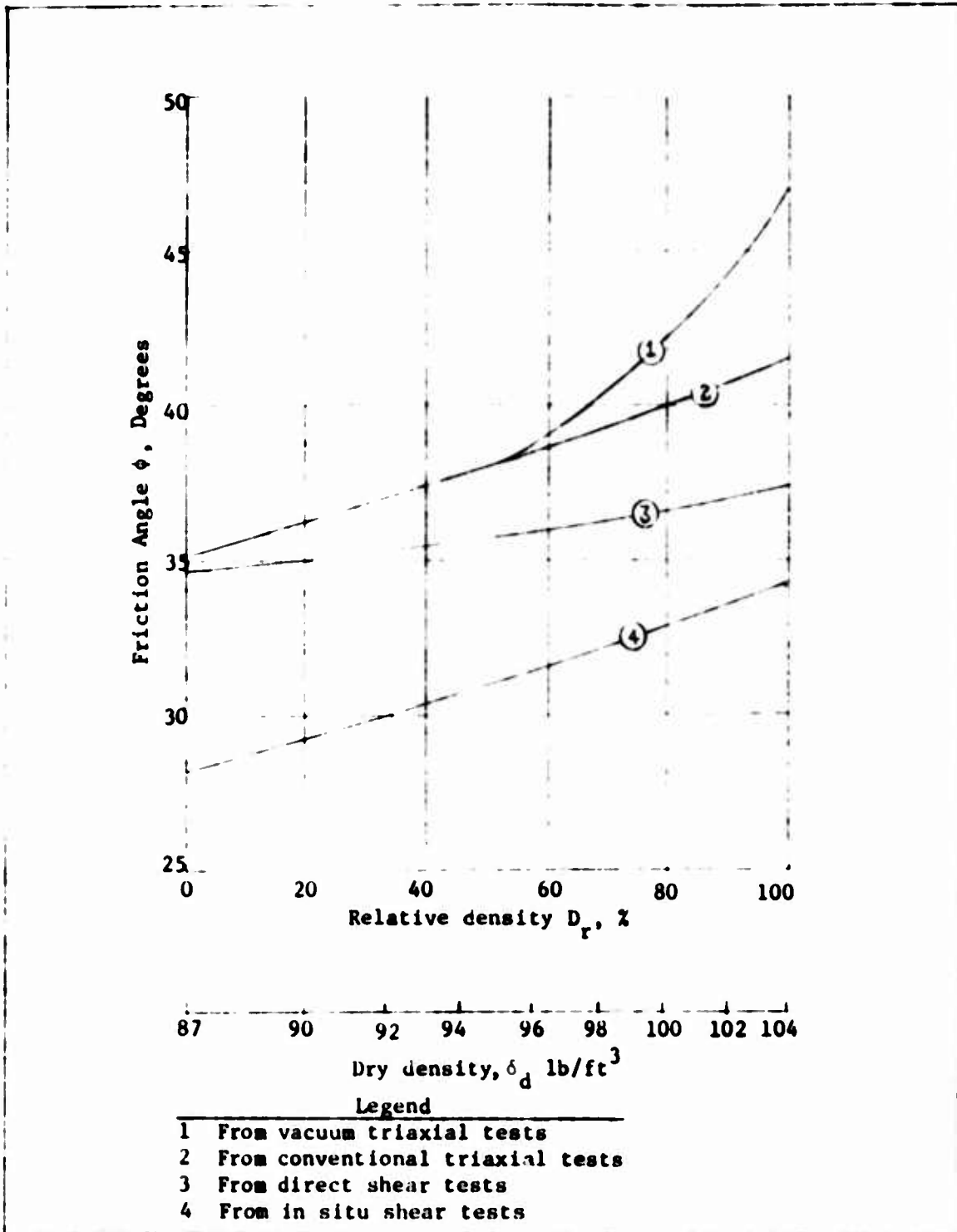

Figure 22. Friction angles of Yuma sand from various test methods as function of density (data from reference 24)

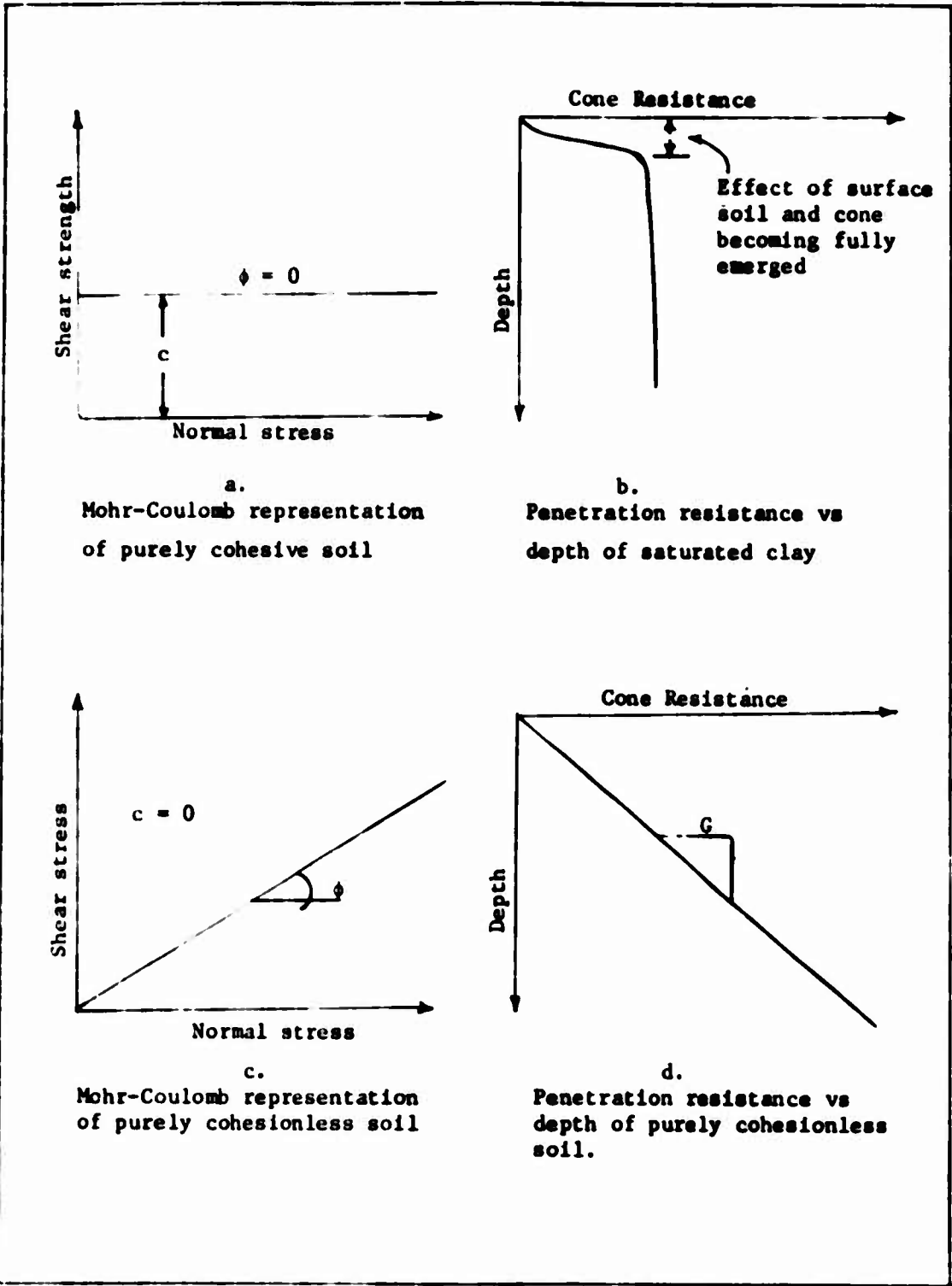
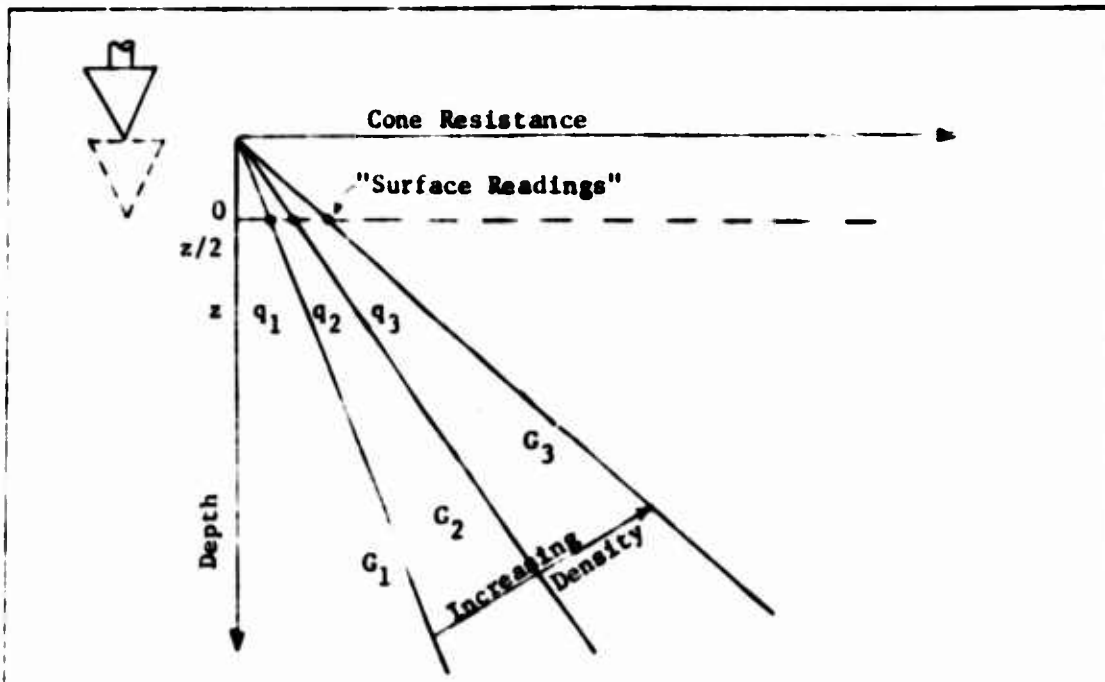

Figure 23. Cone penetration of soils

some interval of depth. The depths found to be the most critical to pneumatic tire performance are 0-6 in. or 0-12 in., where the zero reading is taken when the base of the cone is flush with the sand surface. A different value of average penetration resistance will be obtained depending upon the depth interval; however, if the resistance-depth relation is linear, then a multiple x of the depth interval will produce xq_c of penetration resistance. For a homogeneous sand, the two forms of penetration resistance are directly related. For example, the relation between q_c and G (Figure 21b) for Yuma sand was found to be $q_c = 3.66 G$, when q_c is expressed in lb/in.² and G in lb/in.³ Obviously, if the density of the sand medium were increased, a larger gradient value would result (Figure 24a). Similarly, the value of q_c would increase directly as previously shown.

61. One natural phenomenon of sand beaches and their influence on cone penetration resistance needs further discussion, i.e. if the density of the sand increases with increasing depth (a valid assumption for sand beaches), the shear strength parameter, ϕ , likewise increases because the angle of internal friction for a given sand type is primarily a function of density. As illustrated in Figure 24b, the penetration resistance versus depth relation is no longer linear, i.e., G is not constant; also q_c 's at differing depth intervals cannot be directly related. Finally, the linear relation between G and q_c no longer exists. In situations where density of beach sand varies with depth, it is imperative that density profiles be obtained to complement cone penetration resistance data.

62. Relating pneumatic tire performance to some "critical depth" has been found to depend on many factors, but generally speaking, the zone of full mobilization of shear strength has been found not to exceed 1 to 1.5 times the tire diameter. This depth-of-interest criterion applied to the CAT 824 with an unloaded tire width of 30.5 in. would exceed the capacity of the WES hand-held cone penetrometer. Since beach sand normally increases in density with depth (the upper 4 in. of beach sand is generally dry and loose inland of the surf line) and in



a. Influence of sand density on cone penetration resistance

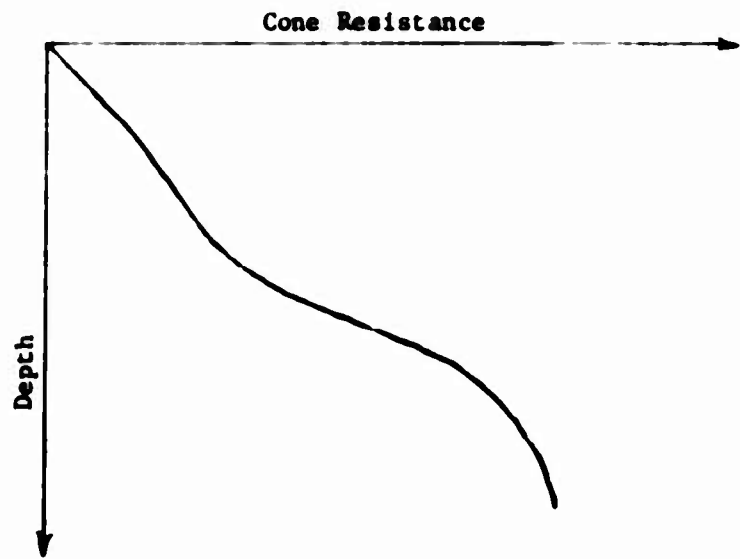

b. Representation of cone penetration resistance as soil density increases with depth

Figure 24. Cone penetration in sand

consideration of the loads and tire sizes, shallow penetration relations should be used with extreme caution. Preferably, cone penetration resistance data should be obtained below the 18 in. depth.

Estimating critical depth

63. A mathematical model for pneumatic tire-soil interaction developed and reported by Karafiath²⁶ was used to determine the effect of sand strength on the traction performance of a single powered tire and to examine the slip line geometry of the tire for a given sand strength. The data input was simplified and constrained to conform to the following assumptions of Karafiath's model:

- a. The tire travels in a straight line at a constant, low velocity.
- b. A "steady state" exists in the soil and the soil's behavior can be described as perfectly plastic.
- c. The tire load is constant; that is, there is no interaction between tire and suspension system.
- d. The terrain is smooth and level.

64. Pertinent tire data used in this analysis (from Table 1) and power requirements are as follows:

- a. Tire radius = 3.225 ft
- b. Tire width = 2.542 ft
- c. Most adverse single tire load = 66,500 lb
- d. Tire deflection = 25 percent
- e. Tire inflation pressure = 72.5 psi
- f. Tire slip = 20 percent

65. With the above variables held constant, the strength of the sand in terms of cone penetration resistance gradient, G , was varied in four increments from 7.5 to 15.0 lb/in³. The relations for tire-sand interaction developed by Karafiath²⁶ were based on single wheel laboratory test data conducted by WES on Yuma sand. Hence, this analysis assumes that the hypothetical beach under investigation consists of sand with physical and engineering properties identical to those of Yuma sand. Performance of a single tire/wheel with the above characteristics was examined at four penetration resistance gradients from 7.5 to 15.0 G .

66. Figure 25a illustrates the relation between pull coefficient (pull/tire weight) and sand strength in terms of G as determined with Karafiath's soil-tire model. The curve drawn through the data points indicates that a sand strength equivalent to a G value of 7.5 lb/in.^3 is necessary to achieve positive pull (i.e. useful work). From Figure 21b a G of 7.5 lb/in.^3 results when Yuma sand has a relative density of about 75 percent.

67. Regardless of the beach stabilization procedure chosen or available to improve a beach for trafficability, the depth of stabilization (i.e. stabilized section thickness or for layered systems, the equivalent thickness) is perhaps of prime importance. Figure 25b illustrates qualitatively the geometry of the analytical plastic slip planes beneath one of the carrier's tires and indicates the depth within the soil mass undergoing shear displacements due to the dynamics of the vehicle's rotating tire. AMC-71 (paragraph 3) provides a means for assessing vehicle-soil conditions against mobility requirements; however, it does not provide the boundary geometry of displaced soil directly beneath a vehicle's tires. Although the analytical method of the type presented herein does not determine the thickness or strength requirements to stabilize a beach material having substandard trafficability properties, insight can be gained as to the depth of tire-soil interaction and thereby establish an important parameter in designing a stabilized section to upgrade the beach material for trafficability purposes.

Beach Stabilization for Trafficability Purposes

68. Previous discussion has indicated the high probability that many sand beaches around the world would permit only marginal operations or cause complete immobilization of heavily loaded container carriers. The process of improving the properties of soils by physical or chemical means to meet specific needs is known as "soil stabilization." Beach stabilization for trafficability purposes might be classed under three

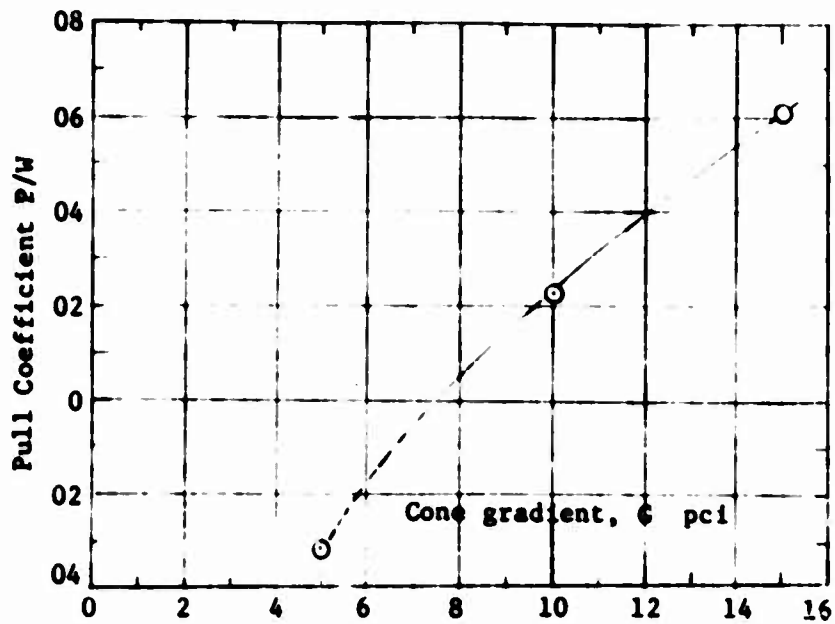

- a. Pull coefficient versus cone penetration resistance gradient for 29.5-2g, 40 PR tire operating in Yuma sand at 20 percent slip. Tire deflection = 25 percent, $W = 66,500$ lb

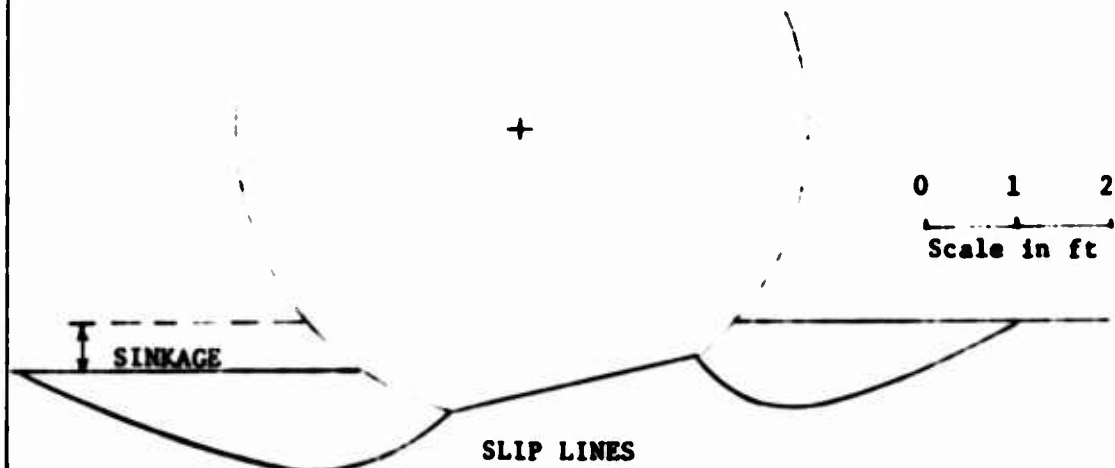

- b. Slip line geometry of tire-soil model for $G = 15$ pci

Figure 25. Predicted results of Karafiath's tire-soil model²⁶

broad groups:

- a. Densification (or mechanical consolidation), wherein a mechanical process is used to pack soil particles closer together with air or water being expelled from the soil mass. The principal parameters of cohesionless soils affected by compaction are instantaneous settlement and increased shearing resistance.
- b. Alteration of the soil structure or individual soil particles by adding nonsoil mixtures to the soil to improve its trafficability characteristics.
- c. Surfacing of the beach to provide a structure whose primary function is to spread the concentrated load of a vehicle's wheels sufficiently so that the underlying soil can support the load without failure or excessive deflections.

Densification

69. A soil with the most favorable engineering characteristics in terms of maximum density and shearing resistance is obtained when the voids in coarse aggregates are filled with sand, the voids in sand are filled with silt, and the voids in silt are filled with clay. (Care should be taken that the clay portion of the mass is not excessive or of such an abnormally active nature that it destroys the bearing capacity of the compacted mass.) The success of this granulometric improvement depends on availability and selectivity of the proper soil types, design of a suitable mix, and determination of the correct amount of water required for achieving optimum compaction characteristics. Of course, this method cannot generally be considered an expedient means of stabilizing a beach lane suitable for traffic. Space does not permit full discussion of mix design and construction methods for granulometric stabilization. This methodology is common in highway and airfield engineering and is well documented within those disciplines (see Appendix A).

70. Densification of in situ beach sands by mechanical means involves the compaction of the soil by some type of equipment that must have the necessary mobility characteristics to operate on the natural

beach. Tractors and vibrating equipment are most satisfactory for cohesionless soils and sheepsfoot rollers for cohesive soils. Vibratory compactors are the most effective means of densifying sand; however, they are completely ineffective in or about the surf line (i.e. operating in totally saturated sands). Achieved density depends on the vibratory roller's characteristics, the roller's rate of travel, and the number of passes applied to each lift. Generally, the rate of travel is between 1.5 to 2.5 ft/sec. Important roller characteristics include roller static weight, operating frequency, and centrifugal force generated. For thin sand lifts (1 to 2 ft) a lightweight roller operating at high frequencies is desirable. Conversely for thicker compacted lifts, a heavy roller operating at low frequencies would be most beneficial. Improvement in densities down to a depth of 10 ft in loose sands have been reported²⁷ with 8-10 coverages of very heavy vibrating mechanical compactors (20-25 kips); however, the upper 1 ft or so of material tended to loosen under the action of the roller making this rather sophisticated construction equipment ineffective for improving sand beaches for trafficability purposes. This particular example was included in this discussion to illustrate the danger of adapting equipment and procedures developed for other engineering problems.

Alteration of soil structure

71. Many different methods for admixture stabilization have been proposed but few are in current practice. But for improving sandy beaches for the specific task of supporting container carrier traffic, only those admixture stabilization methods under the general heading of cementing will be considered in this discussion. Stabilization by cementing consists of using agents that bond the soil particles together without alteration of their chemical composition. The most pronounced benefit is an increase in strength by providing or increasing cohesion; when the cementing agent is relatively rigid, the modulus of elasticity of the soil can be increased and its compressibility decreased. Care should be exercised in selecting cementing agents for stabilizing beach sands to assure that the potential agent is not adversely affected by the salinity or alkalinity of beach material.

72. Soil-cement stabilization. In soil-cement stabilization Portland cement is used to form a mixed-in-place concrete or mortar in which the soil is the aggregate. In a given operation the proper mix is determined by a trial procedure to obtain the required durability and strength. However, a mixture of 4-6 percent by dry weight of Portland cement added to clean beach sand would normally produce a compactable medium capable of obtaining sufficient strength to support the operation of the CAT 824 (see paragraph 84). Compaction may be very difficult and care should be exercised that segregation of sand and cement does not occur. Approximately 7 days would be required for proper curing of a compacted cement-stabilized section. A typical 7-day unconfined compressive (UCC) strength of 130 psi could be expected for a 5 percent cement mixture with beach quartz sand. If the cement content is doubled (i.e. 10 percent) a 7-day UCC strength of 500 psi would be expected.²⁸ This method is not recommended for use in the wet portion of a beach.

73. Lime-fly ash stabilization. Lime-fly ash resembles soil-cement in that pozzolanic cement is created by the reaction of lime on the silica of the fly ash. Typical requirement for sand beaches is 10 percent by weight of a mix consisting of two parts ash to one part lime mixed with the sand and compacted in the same way as Portland cement.

74. Bituminous binders. Bituminous binders have found wide use in stabilizing sandy soils containing little or no clay, such as sand or shell beaches. Usually, asphaltic cutbacks such as RC-1, RC-3, MC-1, and MC-3 are used in amounts varying from 4 to 7 percent by weight. Wet sands are not generally suitable for such binders because of the difficulties encountered during mixing and because the addition of liquid in excess of the water naturally present can render the soil impossible to compact. One method to partially alleviate this problem is the addition of 1 to 2 percent by dry weight of hydrated lime, which promotes adhesion between the bitumen and the wet sand.

75. The Florida Highway Department uses the following relation to determine the amount of emulsified asphalt base required to stabilize clean quartz sand for traffic:²⁸

$$P = 0.75(0.05A + 0.10B + 0.50C)$$

where

P = percentage of emulsified asphalt based on sand dry weight.

A = percentage of sand retained on a No. 10 sieve.

B = percentage of sand retained on sieves between No. 10 and No. 200.

C = percentage of sand passing a No. 200 sieve.

76. Aniline and furfural. Aniline, a liquid coal-tar derivative, and furfural, an organic liquid refined from corn, in the ratio of two parts to one, react to form a deep-red viscous resin that hardens to a solid slowly by polymerization. The liquids are added separately to the soil and mixed intimately, and the total mixture is then compacted. The rate of reaction can be controlled by catalysts, the more successful ones being $FeCl_3$ and pentachlorophenol, such that the sand can be trafficked within a few hours after the stabilizer is applied.

77. The amount of stabilizer that must be added to the sand ranges from about 3 percent by weight of the dry sand for those sands of intermediate fineness and uniformity to about 7.5 percent or even 10 percent for sands with larger specific surfaces, such as those derived from shells or coral.

78. Urethane. Recent unpublished studies at WES have shown that certain members of the urethane family hold great promise as stabilizing agents. One particular compound sprayed on an area of plastic clay of high water content and containing free water (i.e. a mud hole) permitted traffic after 5 min. of curing. A mixture of 5 percent polyurethane by weight and a clean fine-to-medium size sand produced compressive strengths comparable to that of concrete after 4 hr of curing. Current work is needed to define the engineering properties and develop practical and expedient means of applying urethanes to beach sands.

Surfacing by temporary roadways

79. If a particular beach cannot be stabilized satisfactorily by expedient means, temporary bridges or roadways can be constructed, stretching from the landing craft to the stable sand on or beyond the

backshore. In the sense of improving soil properties, the construction of a temporary roadway cannot be considered a method of soil stabilization. However, since the function of a temporary surfacing is essentially the same as that of a stabilized soil, a brief description of several types of temporary roadways should be mentioned.

80. Mats. Considerable effort has been devoted since World War II in a continuing development of steel and aluminum landing mat used to provide surfacing expeditiously for aircraft operation. The criteria for soil beneath landing mat have been developed for clays having a CBR of 4 or greater. The extrapolation of these criteria to cohesionless soils is not possible, primarily because of basic and inherent differences in the reaction of cohesive and cohesionless soils to lateral confinement. The relations of beach sand properties to landing mat performance is not completely known, and both theoretical modeling and field measurements are quite obviously needed. However, landing mat will confine the sand and as a general rule the confined sand will have adequate bearing capacity.

81. Meshes. Plastic or steel meshes may be used to provide restraint to shearing forces in a soil, and the reduction of lateral strain in cohesionless soils. The strain is directly related to the elastic modulus of the mesh. Plastic meshes are subject to creep, for which adequate design data are not available. However, these plastics can tolerate great strains (up to 100 percent) without rupture at any loss of fiber strength.

82. A mesh of suitable strength and durability is laid directly on the ground and a chosen depth of fill is placed thereon. The depth of fill should not exceed the least dimension of wheel contact area, but should extend to slip planes calculated from active and passive pressures caused by the wheel action. Either the mesh should be returned continuously into the next layers of fill, or the ends should be well secured. Choice of mesh size is made according to the mean soil particle size. For sands, arching which is assumed, the size of mesh openings should not exceed five times the mean diameter of the sand particles.

83. A logical extension of using meshes to improve trafficability over sand beaches might be the development of a flexible framework of

thin-walled right cylinders, each having a diameter less than one half the tire width and a length of about 1.0 to 1.5 that of the cylinder's diameter. Such a framework constructed of reinforced fabrics could be deployed on the beach to form a traffic lane for container carriers and the openings filled with beach sand to form a deterrent to lateral movement of the sand as wheel loads are applied.

An example of beach stabilization

84. Assume that a beach is suitable for stabilizing with Portland cement and the appropriate type and amount of stabilizer has been determined. The next step is the determination of the required design thickness. For discussion purposes assume that a quartz beach sand having an average foreshore slope of 5 percent and a cone index of the 0- to 6-in. layer of 45 psi has been selected for a site in which CAT 824 will be used to transport 50,000-lb containers across the beach's foreshore to an assembly area. Figure 3 indicates that a cone index of approximately 50 would be required for the CAT 824 with 35-psi tire pressure to negotiate one pass a 5 percent slope. Therefore, this particular beach with an average cone index of 45 psi would offer only marginal or no-go mobility to the CAT 824. Further assume that the engineering properties of this hypothetical beach sand are the same as those of Yuma sand. It is not necessary (only convenient) to make this assumption. Melzer²⁵ has illustrated that good correlations of cone penetration resistance exist for different sands at the same relative density. Best correlation exists for sands having similar physical properties, i.e. mineral composition, a regularity of grain shapes, and gradation characteristics. Hence, the relations between cone penetration resistance and relative density for one sand can be used to predict the cone penetration resistance and trafficability performance on another sand by knowing the relative density of the latter sand. Enter Figure 21b at a cone penetration resistance of 45 psi; an abscissa value of dry density of 101.7 lb/ft³ is noted. Use this value to enter the abscissa of Figure 21a and move upward to the curve then horizontally to the ordinate; a CBR value of 2.2 results.

85. Compared to laterally confined sand mediums, significant bearing resistance will not develop in sands if the deforming loads are applied to

an unconfined surface. Although a 10-lb surcharge was placed on the loaded surface of the laboratory test specimens used in developing the CBR versus density relation illustrated in Figure 21a, somewhat higher bearing values are no doubt realized for subgrade sands which are totally confined beneath pavement or stabilized sections. Unpublished field CBR tests were performed at Eglin Air Force Base, Florida on a poorly graded fine to medium sand beneath existing flexible pavements by cutting through the section and performing CBR tests at the surface of the sand subgrade. CBR values generally ranged from 4 to 14 for these in situ surface subgrade tests. References 29 and 30 were used to extrapolate a design section from the assumed situation. Paragraph 7-2-b of TM 5-822-5³⁰ provides guidance for assigning a design index based on typical magnitudes and composition of expected traffic for a flexible pavement. The largest forklift truck considered is for a gross weight of 50,000-lb and assigned a design category VI; a 120,000-lb tracked vehicle is assigned the highest design category of VII. Combining these two categories with various traffic volume rates, the specified design index varied from 7 to 10. A flexible section can be derived via the use of a pavement design graph that relates CBR and design index to required thickness. Table 7-2 of reference 29 provides equivalent stabilized material thickness for various combination of soil and stabilizers based upon total thickness required of conventionally designed flexible pavement sections. The following tabulation is based on a flexible pavement design index of 7, CBR values of the unstabilized coarse grained subgrade of 2.2, 4, and 9, and Portland cement as the stabilizing agent.

<u>CBR</u>	<u>Conventional Design Thickness of Flexible Pavement Section, inches</u>	<u>Cement Stabilized Section inches</u>
2.2	41	23
4	24	14
9	17	11

The required section thickness (whether flexible pavement or soil-cement section) exponentially decays as CBR increases; hence for numerically small values of CBR, the required thickness is quite sensitive to relative small

changes in the CBR as illustrated in the above tabulation. As previously mentioned, the CBR test unreasonably penalizes the surface strength of clean sand; nevertheless, the CBR method is the most prevalent design and construction control procedure currently employed in military engineering construction. Immediate need exists for determining the relations between CBR and sand behavior as a construction material.

Development of user manual for
sand beach stabilization

86. Briefly stated, the principal problem of off-shore container discharge extends from the containership to the backshore line of communication (LOC) or rear assembly area. A joint Army-Navy venture is actively developing the technology to utilize fully the benefits of containerization methods. Equipment used for transporting containers over the beach and the improvement of that beach when necessary represent items of this emerging technology that must be actively pursued and formulated into practical technology. Material handling concept developments in the theater of operations have been somewhat hindered due in part to the rapid growth and development of containerization technology.

87. A definite need exists for providing those persons responsible for the planning and the execution of over-the-beach operations with specific guidance pertaining to beach stabilization. Selection of one of the previously discussed stabilization methods would depend on the specific beach involved, as well as the mission requirements as projected through the tactical and logistical constraints. Hence, adequate stabilization guidance must be sensitive to the actual situation as the adoption of any one stabilization method is scenario-dependent. Therefore, a finite number of scenarios should be established and used to evaluate concepts, existing containerization technology, and identify research needs. Established scenarios will allow the analysis of the following variables during the selection of the various stabilization methods.

- a. The time available for stabilizing the beach.
- b. The amount of ship space available to transport the stabilization material, equipment, and personnel.
- c. The local availability of stabilizing material.
- d. Specific beach properties.
- e. Anticipated life expectancy of beach traffic.

PART IV: CONCLUSIONS AND RECOMMENDATIONS

Conclusions

88. Based on analysis of data herein, the following conclusions are drawn:

- a. On the average, for a given layer (0- to 6- or 0- to 12-in.) quartz sands are stronger than volcanic sands, which are, in turn, stronger than coral sands. In a comparison of frequency distributions of strength of beaches and deserts (quartz sands only), the strength of the 0- to 6-in. layers are about the same, and the beach 0- to 12-in. layer is stronger than the same layer of desert sand (paragraph 24).
- b. By using vehicle performance curves and curves of frequency of occurrence of sand strength developed herein, performance of the CAT 824 can be estimated on an areal basis (Table 6). For example, at 35-psi inflation pressure it can negotiate 95 percent of the level quartz beaches, and at 72.5 psi it can negotiate only 72 percent of the level quartz beaches (paragraph 25).
- c. If a 5-percent beach slope is encountered, the percentages of quartz beaches negotiable reduces to 76 and 13, respectively, for 35- and 72.5-psi inflation pressures (paragraph 26).
- d. On a worldwide basis, the total coastal length of all continents is estimated to be 162,805 miles and the cumulative length of sand beaches was estimated to be 12 percent (19,680 miles) of the total length. Assuming beach operations are possible only on sand and that slopes greater than 5 percent will not be encountered, then the amounts of operational beach distances for the CAT 824 are 14,957 miles (9.2 percent of the total) when operating at 35-psi inflation pressure and 2558 miles (1.6 percent of

the total) when operating at 72.5-psi inflation pressure (paragraph 37).

- e. On a worldwide basis of the total land mass, approximately 14 (7,250,530 square miles) percent is covered with sand regions. Assuming that operations in these regions would require the CAT 824 to negotiate slopes not greater than 10 percent (inland sand regions have steeper slopes than beaches), then at 35-psi inflation pressure, 56 percent (4,000,297 square miles) of the regions could be negotiated; and at 72.5-psi inflation pressure, none of the regions could be negotiated (paragraph 38).
- f. For the contiguous United States if slopes greater than 5 percent are not encountered, of the 4221 miles (48 percent of the total) of sand beach 3208 miles ($4221 \times .76$) are negotiable by the CAT 824 at 35-psi inflation pressure and 549 miles ($4221 \times .13$) are negotiable at 72.5-psi inflation pressure (paragraph 37).
- g. Practical stabilization of beach sands may be achieved by densification of the sand, by the introduction of cementing agents to increase the sands' bearing capacity, or by construction of temporary roadways (paragraphs 68-83).
- h. Current design and evaluation methods employed in stabilization of natural soils for enhancing construction material used in road and airfield construction are not entirely applicable for designing expedient stabilized beach sand sections for transportation throughways (paragraph 84).

Recommendations

- 89. It is recommended that:

 - a. The current system for predicting vehicle performance in sand and the frequency distributions of strength curves in sand be used to estimate the performance of other materials handling equipment.

- b. Research be performed to determine the performance capabilities of the CAT 824 and other materials handling equipment on other surface media, such as fine-grained soils and snow.
- c. Additional sand beaches be characterized for trafficability purposes to enhance the present data base.
- d. Analytical engineering relations be developed to properly appraise deficient or marginal sand beaches that might be transformed, by stabilization, into acceptable traffic throughways. These relations would rely heavily upon currently used measured of performance such as the California Bearing Ratio, cone penetration resistance, and triaxial compression testing. This approach should preserve the more familiar and established forms of design parameters yet produce the analytical framework and supplementary engineering data base specifically needed in beach sand stabilization for transportation purposes.
- e. Performance of existing landing mat placed on a natural beach sand and subjected to traffic from container carriers be evaluated.
- f. The many natural and synthetic resins presently available be evaluated for stabilizing beach sands.
- g. Expedient, expandable, and economical means be developed for using meshes or other lateral restraining devices that would significantly reduce sinkage of wheeled container carriers, which results from the lateral displacement of the traversed beach sand.

REFERENCES

1. Army Research and Development News Magazine, May - June 1972.
2. U. S. Army Engineer Waterways Experiment Station Office Report, "Participation in Forklift Truck Testing on Fort Story Beach, Virginia," March 1973.
3. U. S. Army Engineer Waterways Experiment Station, CE, "Beach Trafficability Testing with Off-Road Material Handling Equipment," Miscellaneous Paper M-74-5, Aug 1974, Vicksburg, Miss.
4. U. S. Army Tank-Automotive Command, "The AMC-71 Vehicle Mobility Model," TR 11789 (LL143), Jul 1973, Warren, Mich.
5. U. S. Army Engineer Waterways Experiment Station, CE, "Trafficability of Soils; Pilot Study, Tests on Coarse-Grained Soils," Technical Memorandum No. 3-240, 13th Supplement, Nov 1955, Vicksburg, Miss.
6. _____, "Trafficability of Soils; Tests on Coarse-Grained Soils with Self-Propelled and Towed Vehicles, 1956 and 1957," Technical Memorandum No. 3-240, 15th Supplement, Jun 1959, Vicksburg, Miss.
7. _____, "Trafficability of Soils; Tests on Coarse-Grained Soils with Self-Propelled and Towed Vehicles, 1958-1961," Technical Memorandum No. 3-240, 17th Supplement, May 1963, Vicksburg, Miss.
8. _____, "Trafficability of Soils; Development of Vehicle Performance Prediction Equations and Classification System for Coarse-Grained Soils," Technical Memorandum No. 3-240, 20th Supplement, Apr 1974, Vicksburg, Miss.
9. _____, "The Unified Soil Classification System," Technical Memorandum No. 3-357, May 1967, Vicksburg, Miss.
10. The New Encyclopedia Britannica, Vol 6, 15th Ed., 1974.
11. John T. McGill, "Map of Coastal Landforms of the World," The Geographic Review, Vol 48, 1958.

12. U. S. Army Engineer Division, North Atlantic, CE, "National Shoreline Study, Regional Inventory Report, North Atlantic Region," Vols I & II, 1971, New York.
13. U. S. Army Engineer Division, South Atlantic, CE, "National Shoreline Study, Regional Inventory Report, South Atlantic-Gulf-Region-Puerto Rico and the Virgin Islands," Aug 1971, Atlanta, Ga.
14. U. S. Army Engineer District, New Orleans, CE, "National Shoreline Study, Inventory Report - Lower Mississippi Region," Jul 1971, New Orleans, La.
15. U. S. Army Engineer District, Galveston, CE, "National Shoreline Study, Regional Inventory Report - Texas Coast Shores," 1971, Galveston, Tex.
16. U. S. Army Engineer Division, South Pacific, CE, "National Shoreline Study, California Regional Inventory, Aug 1971, San Francisco, Calif.
17. U. S. Army Engineer Division, North Pacific, CE, "National Shoreline Study, Inventory Report, Columbia-North Pacific Region, Washington and Oregon," Aug 1971, Portland, Oregon.
18. Oxford World Atlas, Oxford University Press, New York, 1973.
19. Snead, Rodman E., Atlas of World Physical Features, Wiley and Sons, New York, 1972.
20. Casagrande, A., "Characteristics of Cohesionless Soils Affecting the Stabilizing of Slopes and Earth Fills," Journal of the Boston Society of Civil Engineers, Vol 23, 1936, pp 13-32.
21. Taylor, D. W., Fundamentals of Soil Mechanics, 14th Printing, Wiley and Sons, New York, Feb 1965, pp 354-359.
22. Castro, G., "Liquification of Sands," Ph.D. Thesis, Jan 1969, Harvard University, Cambridge, Mass.
23. U. S. Army Engineer Waterways Experiment Station, CE, "Aircraft Operations on Unsurfaced Soil, Soil Measurements and Analysis, Project Rough Road Alpha," Technical Report No. 3-624, Jun 1963, Vicksburg, Miss.

24. Freitag, D. R., Green, A. J., and Melzer, K.-J., "Performance Evaluation of Wheels for Lunar Vehicles," Technical Report M-70-2, Mar 1970, U. S. Army Engineer Waterways Experiment Station, CE, Vicksburg, Miss., p 54.
25. Melzer, K.-J., "Measuring Soil Properties in Vehicle Mobility Research, Relative Density and Cone Penetration Resistance," Technical Report No. 3-652, Report 4, Jul 1971, U. S. Army Engineer Waterways Experiment Station, CE, Vicksburg, Miss.
26. Karafiath, L. L., "Development of Mathematical Model for Pneumatic Tire-Soil Interaction," TACOM Technical Report No. 11900 (LL147), Jul 1974, U. S. Army Tank-Automotive Command, Mobility System Laboratory, Warren, Mich.; Prepared under contract.
27. Moorhouse, D. C., and Baker, G. L., "Sand Densification by Heavy Vibratory Compactor," ASCE Specialty Conference, Cambridge, Mass., Aug 1968, pp 379-388.
28. Ingles, O. G., and Metcalf, J. B., Soil Stabilization--Principles and Practice, Wiley and Sons, New York, 1973, p 155.
29. Brabston, W. N., and Hammitt, G. M., II, "Soil Stabilization for Roads and Airfields in the Theater of Operations," Miscellaneous Paper S-74-24, Sep 1974, U. S. Army Engineer Waterways Experiment Station, CE, Vicksburg, Miss.
30. Headquarters, Department of the Army, "Flexible Pavements for Roads, Streets, Walks and Open Storage Areas," Technical Manual TM 5-822-5, Jan 1971, Washington, D. C.

Table 1

50,000-lb-Capacity Container Handler Vehicle Characteristics

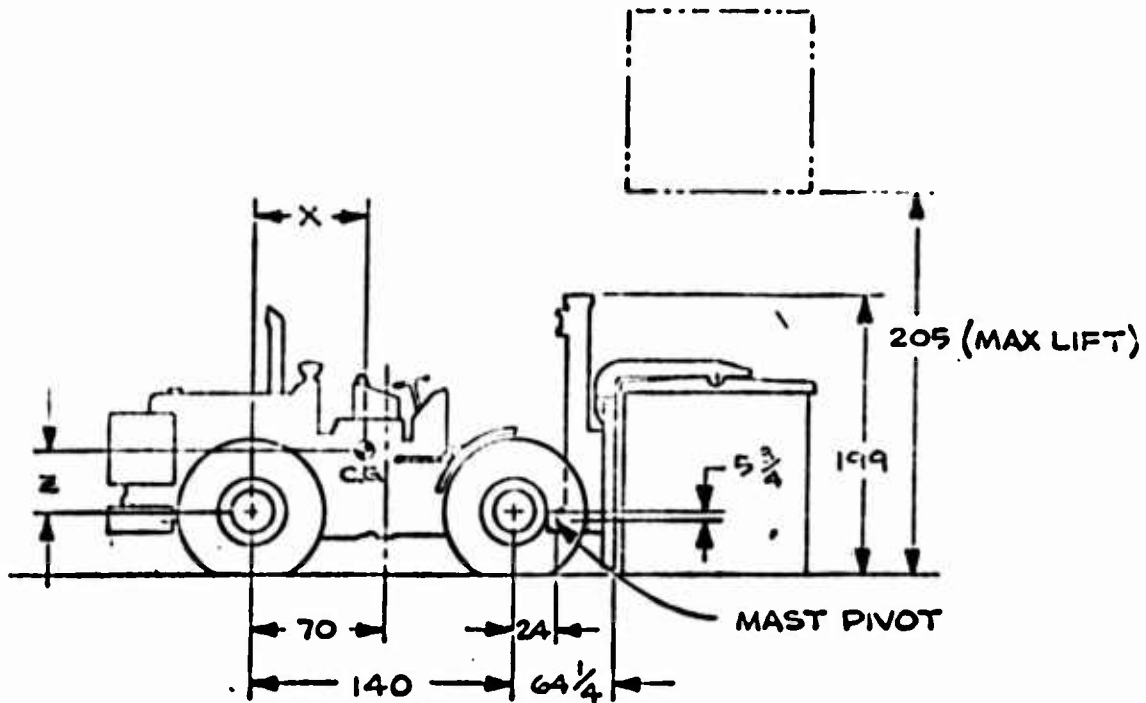

Component Weight Data, lb	CG Location, in.	
	Weight and Tilt	X Z
Front Axle	18,000	Empty (Carry - 12°) 53 27
Rear Axle	32,200	Loaded (Carry - 12°) 108 35
Lift Mast	14,000	Loaded (Full Height - 0°) 113 104
Mast Carriage	6,100	
Container Handler	6,800	
<u>Mast and Carriage Data</u>		
Counter Weights		
Rear Tire Ballast	4,000	Maximum Tilt Forward - 2°
Above Rear Bumper	17,300	Maximum Tilt Back - 12°
Below Rear Bumper -	6,000	Load Capacity - 50,000 lb
		Height (w/mast extended) - 325 in.
		Side Shift - 7.75 from center
		15.50 total

(Continued)

(Sheet 1 of 3)

Table 1 (Continued)

<u>Assembled Unit Weight Data, lb</u>		<u>Physical Dimensions (not shown above), in.</u>	
Empty		Width (without lift attachment)	- 124
Front axle	44,700	Width (with lift attachment)	- 242
Rear axle	65,300	Height (with mast)	- 207
Total	110,000	Length (less mast attachment)	- 290
		Length (with mast attachment)	- 388
Loaded			
Front axle	133,000		
Rear axle	27,000		
Total	160,000		

Tire Data

Standard Tires - Goodyear Super Hard Rock Lug
 29.5-29, 40-PR. Undelected outside diameter = 77.4 in.; undelected width 30.5 in.

Radial-Ply Tires - Michelin Steel Cord, Two Star Rating
 29.5-29 XKB

<u>Load/Tire</u>	<u>Standard Tire</u>			<u>Radial-Ply Tire</u>		
	<u>Inflation Pressure psi</u>	<u>Contact Area sq in.</u>	<u>Ground Pressure psi</u>	<u>Inflation Pressure psi</u>	<u>Contact Area sq in.</u>	<u>Ground Pressure psi</u>
66,500	90	708	93.9	80	856	77.7
	35	965	68.9	62	943	70.5
				50	1048	63.4
				40	1149	57.9
32,650	55	487	67.0	50	689	47.4
	35	598	65.6	35	809	40.4
				25	942	34.7
29,900	62	461	64.8	--	-	-
	50	483	61.9	--	-	-
	35	537	55.7	--	-	-
22,350	--	-	-	80	396	56.4
	--	-	-	62	459	48.7
	--	-	-	50	503	44.4
	--	-	-	40	580	38.5
13,500	50	248	54.4	50	388	34.8
	35	329	41.0	25	516	26.2

(Continued)

(Sheet 2 of 3)

Table 1 (Concluded)

Miscellaneous Data

Horsepower (fly wheel) - 300 at 2060 rpm
Transmission - Single-lever power shift, planetary type; 3 fwd 3 rev
Maximum forward speed - 18.5 mph
Steering - Articulated frame; maximum angle 30°
Final drive - all-wheel planetary
Ground clearance - 37 in.

Table 2

Data Form for Computing Maximum Net Drawbar Pull (DBP_{max}) Maximum

Slope Negotiable (S_{max}) and Towed Motion Resistance (MR) for
Wheeled Vehicles in Sands

Vehicle _____

Basic Equations

DBP_{max} (% of vehicle wt) = 28.87X₁ + 10.10X₂ - 1.52X₃ - 0.61X₄ - X₅ = _____

S_{max} (%) = 28.87X₁ + 10.10X₂ - 1.52X₃ - 0.61X₄ - X₆ = _____

MR (% of vehicle wt) = (22.20 + 0.92X₄) - [(8.0 + 0.37 × X₄) × (X₁)] = _____
Vehicle Characteristics and Cone Index

- | | |
|---|--|
| (1) Gross wt. (with max payload) lb _____ | (2) Nominal tire width, in. _____ |
| (3) Rim diameter, in. _____ | (4) No. of powered tires _____ |
| (5) Tire ply rating _____ | (6) Tire inflation pressure, psi _____ |
| (7) Cone index of critical layer _____ | |

X Factors

X₁ = strength factor - log (7)^a = _____ (logarithm to the base 10)

X₂ = contact area factor = log $\frac{(1)}{(X_3)}$ = _____

X_a = contact pressure factor = 0.607 × (6) + 1.35 $\left(\frac{117.0 \times (5)}{(X_b)}\right)$ - 4.93 = _____

X_b = wheel diameter factor = X₇ × (2) + (3) = _____ (If available, use undeflected outside tire diameter as X_b.)

X₃ = same as (4)

X₄ = same as (6)

X₅ = 43.82 for maximum net drawbar pull computations

X₆ = 45.82 for maximum slope negotiable

X₇ = $\frac{\text{Nominal tire width, in.}}{\text{Rim diameter, in.}}$ = _____
if ≥ 2.4 factor (7) = 2.0
if < 2.4 factor (7) = 5.0

DBP_{max} = 28.87(_____) + 10.10(_____) - 1.52(_____) - 0.61(_____) - 43.82

= _____

S_{max} = 28.87(_____) + 10.10(_____) - 1.52(_____) - 0.61(_____) - 45.82 = _____

^a Numbers in parenthesis indicate the vehicle characteristic, cone index, or X factor to use.

Table 3

Summary of Measured Beach and Desert Area Data

Beach/Desert Location	0-6 in. Cone Index		0-12 in. Cone Index		Slope, %		Sand Origin	Mechanical Analysis, %			Unified Soil Classification	
	Range	Avg	Range	Avg	Range	Avg		Coarse*	Medium*	Fine*		Fines*
<u>Pacific Islands</u>												
<u>Oahu III Beaches</u>												
Makuleia	(14-51)	28	(43-131)	93	(0-24)	12	Coral	0	92	8	0	SP Medium
Drone	(21-48)	26	(40-110)	75	(0-30)	15	Coral	0	97	3	0	SP Medium
Makua	(22-136)	59	(48-135)	92	(0-25)	12	Coral	0	77	23	0	SP Fine to medium
Crescent Bunker	(18-66) (39-85)	36 38	(27-129) (88-145)	79 113	(0-15) (0-25)	8 15	Coral Coral	0 0	12 49	88 51	0 0	SP Fine SP Medium to fine SP Medium
Pokai Bay 1	(28-31)	30	-	118	(0-12)	6	Coral	3	87	10	0	SP Medium
Pokai Bay 2	(22-52)	36	-	74	(0-15)	7	Coral	3	85	12	0	SP Fine to medium
NAD	(26-51)	38	-	89	(0-6)	3	Coral	0	73	27	0	SP Fine to medium
Last	(11-27)	22	-	65	(0-15)	5	Coral	0	98	2	0	SP Medium

* Refer to definitions in text.

(Continued)

(Sheet 1 of 4)

99

Table 3 (Continued)

Beach/Desert Location	0-6 in. Cone Index		0-12 in. Cone Index		Slope, %		Sand Origin	Mechanical Analysis, %			Unified Soil Classification		
	Range	Avg	Range	Avg	Range	Avg		Coarse	Medium	Fine	Symbol	Designation	
<u>Hawaii, HI</u>													
<u>Beach</u>													
Kalapana	(26-78)	41	-	101	(0-12)	8	Volcanic	0	76	24	0	SP	Fine to medium
Kwajalein 1	(47-52)	50	(47-52)	50	(0-14)	7	Coral	0	0	91	0	SP	Fine
Kwajalein 5	(107-128)	118	-	191	(0-13)	7	Coral	10	50	40	0	SP	Fine to medium
Kwajalein 6	(51-153)	84	(122-167)	144	(0-13)	7	Coral	0	28	69	3	SP	Medium to fine
Kwajalein 7	(62-136)	99	-	170	(0-13)	7	Coral	0	13	87	0	SP	Medium to fine
<u>Guam Beaches</u>													
Nimitz	(52-68)	60	-	116	(0-8)	4	Coral	0	9	91	0	SP	Fine
Jones	(31-52)	42	(78-115)	96	(0-14)	7	Coral	4	89	7	0	SP	Medium
Tarague	(40-41)	41	(82-92)	87	(0-20)	10	Coral	1	23	76	0	SP	Medium to fine
<u>Iwo Jima Beaches</u>													
Red	(24-141)	61	(31-150)	83	(0-20)	15	Volcanic	0	64	36	0	SP	Fine to medium
Yellow	(18-88)	43	(31-162)	87	(0-20)	12	Volcanic	5	88	7	0	SP	Medium
<u>Luzon, PI</u>													
Lido	(97-131)	114	-	173	(0-18)	9	Quartz	3	55	42	0	SP	Fine to medium

(Continued)

(Sheet 2 of 4)

Table 2 (Continued)

Beach/Desert Location	0-6 in. Cone Index		0-12 in. Cone Index		Slope, % Range	Avg	Sand Origin	Mechanical Analysis, %			Unified Soil Classification		
	Range	Avg	Range	Avg				Coarse	Medium	Fine	Fines	Symbol	Designation
<u>Brittany, France</u>													
Lalurballe	(26-150)	110	(85-300)	151	(10-25)	15	Quartz	15	74	8	3	SP	Medium to coarse
Suscinio	(51-197)	117	(145-500)	192	(0-10)	8	Quartz	30	55	7	26*	SW	Gravelly
<u>United States Beaches</u>													
Ft. Ord, Calif.	(31-42)	35	-	-	(0-11)	6	Quartz	0	92	8	0	SP	Medium
Monterey, Calif.	(28-98)	62	-	-	(0-10)	5	Quartz	0	3	97	0	SP	Fine
Marina, Calif.	(30-59)	43	-	-	(0-15)	8	Quartz	0	69	31	0	SP	Fine to medium
Camp Cooke, Calif.	(31-71)	48	-	-	(0-10)	6	Quartz	0	7	93	0	SP	Fine
Purisima Point, Calif.	(31-139)	59	-	-	(0-22)	11	Quartz	0	55	45	0	SP	Fine to medium
Padre Island, Texas	(23-300+)	235	(86-300+)	300	(0-10)	5	Quartz	0	0	98	2	SP	Fine

* 2% of material classified as coarse gravel size.

Table 3 (Concluded)

Beach/Desert Location	0-6 in. Cone Index		0-12 in. Cone Index		Slope, %		Sand Origin	Mechanical Analysis, %			Unified Soil Classification		
	Range	Avg	Range	Avg	Range	Avg		Coarse	Medium	Fine	Fines	Symbol	Designation
Lagoon Shell	(25-52) (62-122)	38 93	- (137-211)	- 165	(0-2) (0-12)	1 6	Quartz Quartz	0 2	0 46	98 52	2 0	SP SP	Fine Medium to fine
Ft. Walton, Fla.	(31-186)	125	-	-	(0-25)	12	Quartz	0	10	90	0	SP	Fine
Camp Lejeune (Onslow), N.C.	(50-167)	97	(85-234)	188	(0-30)	13	Quartz	0	0	100	0	SP	Fine
Ft. Story, Va.	(88-126)	105	-	-	(0-25)	10	Quartz	0	20	80	0	SP	Medium to fine
Little Creek, Va.	(58-103)	80	(169-257)	213	(0-23)	13	Quartz	0	14	92	0	SP	Fine
Camp Wellfleet, Mass.	(24-249)	100	(48-158)	157	-	--	-	2	84	14	0	SP	Medium
Duxbury, Mass.	(69-188)	175	-	-	(0-20)	12	Quartz	75*	19	6	0	SW	Gravelly
<u>U. S. Desert Dunes</u>													
Calif sand	(21-141)	81	(25-205)	-	(0-30)	20	Quartz	0	19	74	7	SP	Medium to fine
<u>U. S. Inland Waterways</u>													
Miss. River, Vicksburg Bridge	(98-160)	132	(199-228)	215	(0-5)	3	Quartz	0	4	96	0	SP	Fine
Marshall Cutoff	(85-147)	115	(192-224)	207	(0-2)	1	Quartz	0	25	75	0	SP	Medium to fine
Warren Dunes, Lake Michigan	(16-110)	60	(36-205)	108	(0-50)	20	Quartz	0	24	76	0	SP	Medium to fine

* 40% of material was fine gravel size.

82

Table 4

Cumulative Frequency of Occurrence of Cone Index Ranges, Dry-to-Moist Sand

0- to 6-in. Layer

Cone Index Range	Cumulative Frequency of Occurrence of Cone Index for Various Sand Types in Cited Locations															
	Foreslope of Beach			Backshore of Beach			Apron of Beach			Dune Area of Beach		Desert		All Beach Areas Combined		
	Quartz	Coral	Volcanic	Quartz	Coral	Volcanic	Quartz	Coral	Volcanic	Quartz	Coral	Quartz	Coral	Quartz	Coral	Volcanic
1-10	--	--	--	--	--	--	--	--	--	--	--	--	--	0.5	--	--
11-20	--	--	--	--	6.2	4.0	--	--	1.7	--	--	--	--	0.5	0.7	1.8
21-30	1.5	--	20.0	4.8	30.6	4.0	--	--	6.4	--	--	0.3	--	4.8	14.1	12.7
31-40	14.0	16.7	63.3	16.7	72.9	24.0	--	--	11.9	6.4	4.4	4.4	--	13.5	50.7	45.5
41-50	24.6	37.5	86.7	58.1	87.5	36.0	--	--	18.3	30.3	9.8	20.6	--	25.2	74.8	63.6
51-60	37.5	62.5	96.7	58.7	95.8	52.0	--	--	25.5	78.8	20.6	--	--	37.6	89.9	76.4
61-70	50.4	70.8	96.7	69.8	100.0	60.0	--	--	35.3	84.8	30.2	--	--	47.7	94.8	80.0
71-80	58.0	79.2	100.0	73.8	--	80.0	--	--	44.7	90.9	46.6	--	--	53.9	97.0	90.9
81-90	65.9	79.2	--	77.8	--	88.0	--	--	51.9	93.9	62.9	--	--	60.8	97.4	94.5
91-100	76.5	91.7	--	82.5	--	96.0	--	--	57.9	93.9	79.1	--	--	69.6	98.5	98.2
101-110	83.0	91.7	--	86.5	--	100.0	--	--	63.8	93.9	92.8	--	--	74.9	98.5	100.0
111-120	87.5	95.8	--	89.7	--	--	--	--	66.4	93.9	97.7	--	--	78.9	99.2	--
121-130	90.9	95.8	--	92.1	--	--	--	--	68.1	97.0	99.0	--	--	83.4	99.2	--
131-140	94.3	95.8	--	95.2	--	--	--	--	72.3	97.0	99.7	--	--	87.9	99.6	--
141-150	95.8	95.8	--	96.0	--	--	--	--	76.5	100.00	100.0	--	--	87.9	99.6	--
151-160	97.0	100.0	--	96.0	--	--	--	--	78.7	100.00	100.0	--	--	90.3	99.6	--
161-170	98.1	--	--	96.0	--	--	--	--	81.3	--	100.0	--	--	92.5	100.0	--
171-180	98.9	--	--	96.0	--	--	--	--	85.1	--	--	--	--	94.8	--	--
181-190	99.2	--	--	96.0	--	--	--	--	88.9	--	--	--	--	95.6	--	--
191-200	99.2	--	--	96.0	--	--	--	--	90.6	--	--	--	--	96.6	--	--
201-210	99.6	--	--	96.0	--	--	--	--	93.2	--	--	--	--	97.3	--	--
211-220	100.0	--	--	96.0	--	--	--	--	94.9	--	--	--	--	97.7	--	--
221-230	--	--	--	96.0	--	--	--	--	95.7	--	--	--	--	98.9	--	--
231-240	--	--	--	96.0	--	--	--	--	98.7	--	--	--	--	98.9	--	--
241-250	--	--	--	96.0	--	--	--	--	96.7	--	--	--	--	99.2	--	--
251-260	--	--	--	96.0	--	--	--	--	99.6	--	--	--	--	99.3	--	--
261-270	--	--	--	96.0	--	--	--	--	100.0	--	--	--	--	99.3	--	--
271-280	--	--	--	96.0	--	--	--	--	--	--	--	--	--	99.3	--	--
281-290	--	--	--	96.8	--	--	--	--	--	--	--	--	--	99.4	--	--
291-300	--	--	--	99.2	--	--	--	--	--	--	--	--	--	99.9	--	--
Total number of samples used in analysis	264	24	30	126	144	25	85	69	235	33	388	710	270	55		

83

Table 5

Cumulative Frequency of Occurrence of Cone Index Ranges, Dry-to-Moist Sand
0- to 12-in. Layer

Cone Index Range	Cumulative Frequency of Occurrence of Cone Index for Various Sand Types in Cited Locations																	
	Foreshore of Beach			Backshore of Beach			Apron of Beach			Dune Area of Beach			Desert			All Beach Areas Combined		
	Quartz	Coral	Volcanic	Quartz	Coral	Volcanic	Quartz	Coral	Volcanic	Quartz	Coral	Volcanic	Quartz	Coral	Volcanic	Quartz	Coral	Volcanic
1-10	-	-	-	-	-	-	-	-	-	-	-	-	-	-	-	-	-	-
11-20	-	-	-	-	-	-	-	-	-	-	-	-	-	-	-	-	-	-
21-30	-	-	-	-	-	-	-	-	-	-	-	-	-	-	0.7	-	-	1.1
31-40	-	-	-	-	-	-	-	-	-	-	-	-	-	-	2.1	-	-	1.9
41-50	0.8	-	26.7	-	-	6.7	-	-	1.4	1.1	1.4	3.7	6.1	3.9	1.0	11.1	1.0	20.0
51-60	1.7	8.3	63.3	2.0	25.0	13.3	1.2	2.9	6.3	6.1	6.1	6.3	6.1	5.6	2.7	19.6	43.6	
61-70	2.5	12.5	70.0	4.3	43.5	13.3	2.4	10.1	9.0	6.1	6.1	9.0	6.1	9.1	4.7	30.4	52.7	
71-80	2.5	20.8	73.3	5.9	62.0	20.0	4.8	17.4	13.8	24.2	24.2	13.8	24.2	14.4	6.7	45.9	56.4	
81-90	3.4	29.2	80.0	8.7	76.1	26.7	8.4	43.5	19.6	33.3	33.3	19.6	33.3	19.6	10.1	60.4	65.5	
91-100	5.9	33.3	83.3	12.5	80.4	26.7	8.4	63.8	26.5	42.4	42.4	24.2	42.4	24.2	14.2	69.3	69.1	
101-110	9.2	37.5	90.0	14.8	87.0	33.3	8.4	76.8	31.7	51.5	51.5	28.8	51.5	28.8	16.9	77.0	76.4	
111-120	10.9	54.2	93.3	17.6	92.4	46.7	9.6	85.5	34.9	78.8	78.8	33.7	78.8	33.7	19.5	87.0	81.8	
121-130	16.8	58.3	93.3	19.6	98.9	53.3	12.0	92.8	37.6	78.8	78.8	42.8	78.8	42.8	22.1	91.5	83.6	
131-140	26.9	58.3	93.3	20.9	98.9	53.3	13.3	95.7	40.7	90.9	90.9	53.0	90.9	53.0	25.4	93.7	83.6	
141-150	35.3	58.3	96.7	21.4	100.0	66.7	15.7	97.1	43.9	93.9	93.9	65.3	93.9	65.3	28.0	94.8	89.1	
151-160	40.3	62.5	96.7	21.9	-	73.3	19.3	100.0	46.6	93.9	93.9	76.5	93.9	76.5	30.0	95.9	90.0	
161-170	48.7	62.5	96.7	22.7	-	86.7	25.3	-	49.2	93.9	93.9	90.2	93.9	90.2	32.7	95.9	94.5	
171-180	58.8	66.7	100.0	23.0	-	86.7	32.5	-	51.9	93.9	93.9	95.4	93.9	95.4	35.8	96.3	96.4	
181-190	64.7	79.2	-	23.5	-	100.0	33.7	-	54.5	97.0	97.0	99.3	97.0	99.3	37.6	97.8	100.0	
191-200	73.9	91.7	-	29.6	-	-	49.4	-	57.7	97.0	97.0	99.6	97.0	99.6	44.2	98.9	-	

(Continued)

(Sheet 1 of 2)

Table 5 (Concluded)

Cone Index Range	Cumulative Frequency of Occurrence of Conc Index for Various Sand Types in Cited Locations													
	Foreshore of Beach		Backshore of Beach		Apron of Beach		Dune Area of Beach		Desert		All Beach Areas Combined			
	Quartz	Coral	Volcanic	Quartz	Coral	Volcanic	Quartz	Coral	Quartz	Coral	Quartz	Coral	Volcanic	
201-210	89.1	95.8	-	51.8	-	-	68.7	-	60.8	100.0	100.0	59.5	99.6	-
211-220	96.6	95.8	-	89.5	-	-	81.9	-	74.1	-	-	82.5	99.6	-
221-230	100.0	100.0	-	99.7	-	-	94.0	-	82.0	-	-	90.7	100.0	-
231-240	-	-	-	100.0	-	-	98.8	-	89.4	-	-	93.0	-	-
241-250	-	-	-	-	-	-	100.0	-	93.7	-	-	94.0	-	-
251-260	-	-	-	-	-	-	-	-	98.4	-	-	95.1	-	-
261-270	-	-	-	-	-	-	-	-	99.5	-	-	95.3	-	-
271-280	-	-	-	-	-	-	-	-	100.0	-	-	95.5	-	-
281-290	-	-	-	-	-	-	-	-	-	-	-	95.7	-	-
291-300	-	-	-	-	-	-	-	-	-	-	-	100.0	-	-
No. of tests used in analysis	264	24	30	126	144	25	85	69	235	33	388	710	270	55

Table 6

Performance Estimates for CAT 824B on Beach and Desert Sands

Area	Effective Cone Index (ECI) and % of Area Negotiable (% GO) on Specified Slopes											
	0% Slope		5% Slope		10% Slope		15% Slope		20% Slope		25% Slope	
	ECI	GO	ECI	GO	ECI	GO	ECI	GO	ECI	GO	ECI	GO
Beach (all areas)												
Quartz	31	95	48	76	69	54	103	29	155	9	236	1
Coral	31	83	48	28	69	5	103	1	155	0	236	-
Volcanic	31	85	48	39	69	16	103	1	155	0	236	-
Foreshores												
Quartz	31	93	48	67	69	33	103	17	155	5	236	0
Coral	31	99	48	67	69	30	103	9	155	0	236	-
Volcanic	31	74	48	18	69	2	103	0	155	-	236	-
Backshore												
Quartz	31	93	48	67	69	32	103	17	155	5	236	0
Coral	31	65	48	15	69	0	103	-	155	-	236	-
Volcanic	31	85	48	65	69	39	103	4	155	0	236	-
Forward Dune Apron												
Quartz	31	100	48	94	69	85	103	58	155	8	236	0
Beach Dune Areas												
Quartz	31	88	48	76	69	57	103	36	155	16	236	1
Coral	31	92	48	26	69	10	103	3	155	0	236	-
Desert Dune Areas												
Quartz	31	96	48	82	69	56	103	5	155	0	236	0

35-psi Inflation Pressures

72.5-psi Inflation Pressures

Beach (all areas)							
Quartz	146	72	221	13	356	0	
Coral	146	5	221	0	356	-	
Volcanic	146	12	221	0	356	-	

(Continued)

(Sheet 1 of 2)

Table 6 (Concluded)

Area	Effective Cone Index (ECI) and % of Area Negotiable (GO) on Specified Slopes											
	0% Slope		5% Slope		10% Slope		15% Slope		20% Slope		25% Slope	
	ECI	GO	ECI	GO	ECI	GO	ECI	GO	ECI	GO	ECI	GO
Foreshores												
Quartz	146	77	221	13	356	0						
Coral	146	40	221	0	356	-						
Volcanic	146	4	221	0	356	-						
Backshores												
Quartz	146	77	221	14	356	0						
Coral	146	0	221	-	356	-						
Volcanic	146	35	221	0	356	-						
Forward Dune Apron												
Quartz	146	84	221	20	356	0						
Beach Dune Areas												
Quartz	146	56	221	23	356	0						
Coral	146	11	221	0	356	0						
Desert Dune Areas												
Quartz	146	28	221	0	356	0						

Table 7

Common Strength Parameters Used to Evaluate Soil for Vehicle Support

Parameter	Normal Engineering Units	Principal Vehicle-Related Area of Use	Brief Definition
California Bearing Ratio (CBR)	F/L ²	Highway and air-field design	A measure of shear strength and bearing capacity of soil. It is determined by comparing the bearing value obtained from a penetration-type shear test with a standard bearing value obtained on crushed rock. The standard results are taken as 100 percent, and values obtained from other tests are expressed as percentage of the standard.
Cone penetration resistance (C or G)	Clay: F/L ² Sand: F/L ³	Surface soil exploration; off-road ground mobility	Used as an index of in situ shear strength and bearing capacity of soil. A cone penetrometer consists of a cone mounted on one end of a shaft. The instrument is forced vertically into the soil while records are made of the force applied axially to the penetrometer for various penetration depths.
Mohr-Coulomb shear strength relation (φ-c)	φ: degrees c: F/L ²	Airfield and highway design; off-road ground mobility	The critical combination of normal and shear stresses acting on and causing a shear failure of materials. Most versatile and theoretically founded of the three strength parameters. The principal shear tests to evaluate φ and c of soils are direct and triaxial shear tests. Triaxial testing gives the most consistent and reliable results with varying soils.

*F - force; L - length.

APPENDIX A: SELECTED REFERENCES CONCERNING SOIL STABILIZATION

Densification

1. Bernhard, R. K., "Static and Dynamic Soil Compaction," Proceedings, Highway Research Board, Vol 31, 1952, pp 563-591.
2. D'Appolonia, D. J., Whulman, R. V., and D'Appolonia, E. N., "Sand Compaction with Vibratory Rollers," Proceedings Paper 366, Journal, Soil Mechanics and Foundations Division, Proceedings of American Society of Civil Engineers, Vol 95, No. SM7, Jan 1969, pp 263-284.
3. Headquarters, Department of the Army, "Utilization of Engineer Construction Equipment, Earth Moving, Compaction, Grading and Ditching Equipment," TM 5-331-E, Vol A, Aug 1967, Washington, D. C.

Soil-Cement

4. Hansen, N. G., Soil Cement Roads, National Roads Board, Wellington, New Zealand, 1960.
5. Hutchinson, G. G., "Granulometric Properties of Cement Stabilized Sands," Journal, Soil Mechanics and Foundations Division, Proceedings of American Society of Civil Engineers, Vol 89, No. SM3, 1963, p 95.
6. Portland Cement Association, Soil Cement Construction Handbook, Chicago, Ill., 1956.

Bituminous Binders

7. Gregg, J. S., Dehlen, G. L., and Rigden, P. J., "On the Properties, Behavior, and Design of Bituminous Stabilized Sand Bases," National Institute for Road Research of the South African Council for Scientific and Industrial Research, Report No. RS/11/66, Aug 1966, Pretoria, South Africa.

8. Katti, R. K., Davidson, D. T., and Sheelev, J. B., "Water in Cutback Asphalt Stabilization of Soil," Highway Research Board Bulletin No. 241, Washington, D. C., 1960.

Others

9. Green, H. H. and Ellison, D. A., "Installation of XM19 Airfield Landing Mat and Auxiliary Items," Instruction Report S-69-4, Jul 1969, U. S. Army Engineer Waterways Experiment Station, CE, Vicksburg, Miss.

10. White, D. W., Jr., "Installation of Heavy Duty Tires - Wet Extruded Aluminum Airfield Landing Mat," Instruction Report S-74-2, May 1974, U. S. Army Engineer Waterways Experiment Station, CE, Vicksburg, Miss.

11. Headquarters, Department of the Army, "Planning and Designing Roads, Airbases, and Heliports in the Theater of Operations, Expedient Airfield Surfaces," TM 5-530, Chapter 13, Section 7, Sep 1968, Washington, D. C.

General Interest

12. Brabston, W. N. and Hammitt, G. M., II, "Soil Stabilization for Roads and Airfields in the Theater of Operations," Miscellaneous Paper S-74-23, Sep 1974, U. S. Army Engineer Waterways Experiment Station, CE, Vicksburg, Miss.

13. Highway Research Board, "Soil and Soil-Aggregate Stabilization," Highway Research Bulletin No. 108, Washington, D. C. 1955.

14. _____, "Chemical and Mechanical Stabilization," Highway Research Bulletin No. 129, Washington, D. C., 1956.

15. _____, "Lime and Lime-Flyash Soil Stabilization," Highway Research Bulletin No. 231, Washington, D. C., 1959.

16. _____, "Soil Stabilization with Asphalt, Portland Cement, Lime, and Chemicals," Highway Research Bulletin No. 241, Washington, D. C., 1960.

17. Highway Research Board, "Stabilization of Soils with Portland Cement, Design, Testing, Properties, and Admixtures," Highway Research Bulletin No. 353, Washington, D. C., 1962.
18. _____, "Cement-Treated Soil Mixtures," Highway Research Record No. 36, Washington, D. C., 1963.
19. _____, "Soil-Cement Stabilization," Highway Research Record No. 86, Washington, D. C., 1965.
20. _____, "Stabilized Soils: Mix Design and Properties," Highway Research Record No. 198, Washington, D. C., 1967.
21. _____, "Soil Stabilization: Asphalt, Lime, and Cement," Highway Research Record No. 351, Washington, D. C., 1971.
22. _____, "Soil Stabilization," Highway Research Record No. 442, Washington, D. C., 1973.
23. Ingles, O. G. and Metcalf, J. B., Soil Stabilization - Principles and Practice, Wiley and Sons, New York, 1973.
24. Headquarters, Department of the Army, "Asphalt and Concrete Equipment," TM 5-331-E, Vol D-1, Apr 1965, Washington, D. C.
25. _____, "Engineer Special Purpose and Expedient Equipment," TM 5-331-E, Vol E, Feb 1969, Washington, D. C.
26. _____, "Construction in the Theater of Operations," TM 5-302, 15 Dec 1969, Washington, D. C.
27. _____, "Control of Soils in Military Construction," TM 5-541, Sep 1954, Washington, D. C.
28. _____, "Soil Stabilization for Roads and Streets," EM 1110-345-304, 31 Jul 1961, Washington, D. C.

In accordance with ER 70-2-3, paragraph 5c(1)(b), dated 15 February 1973, a facsimile catalog card in Library of Congress format is reproduced below.

Rush, Edgar S

Estimating the performance capability of 50,000-lb-capacity container handler on beach and desert sands, by Edgar S. Rush and Gary N. Durham. Vicksburg, U. S. Army Engineer Waterways Experiment Station, 1975.

1 v. (various pagings) illus. 27 cm. (U. S. Waterways Experiment Station. Miscellaneous paper M-75-8)

Prepared for U. S. Army Mobility Equipment Research and Development Center, Fort Belvoir, Va.

Includes bibliographies.

1. Beaches. 2. Container handling equipment. 3. Deserts. 4. Sands. 5. Soil stabilization. 6. Soil strength. 7. Trafficability. 8. Vehicles. I. Durham, Gary Neil, joint author. II. U. S. Army Mobility Equipment Research and Development Center. (Series: U. S. Waterways Experiment Station, Vicksburg, Miss. Miscellaneous paper M-75-8)
TA7.W34m no.M-75-8