

AD-A016 787

DESIGN AND POTENTIALS OF THE CALIFORNIUM-252 RADIATION
FACILITY AT WES

Jack T. Lewis, et al

Army Engineer Waterways Experiment Station
Vicksburg, Mississippi

September 1975

DISTRIBUTED BY:

NTIS

National Technical Information Service
U. S. DEPARTMENT OF COMMERCE

315137



MISCELLANEOUS PAPER S-75-26

DESIGN AND POTENTIALS OF THE CALIFORNIUM-252 RADIATION FACILITY AT WES

by

Jack T. Lewis and Ellis L. Krinitzky

Soils and Pavements Laboratory
U. S. Army Engineer Waterways Experiment Station
P. O. Box 631, Vicksburg, Miss. 39180

September 1975
Final Report



Approved For Public Release; Distribution Unlimited

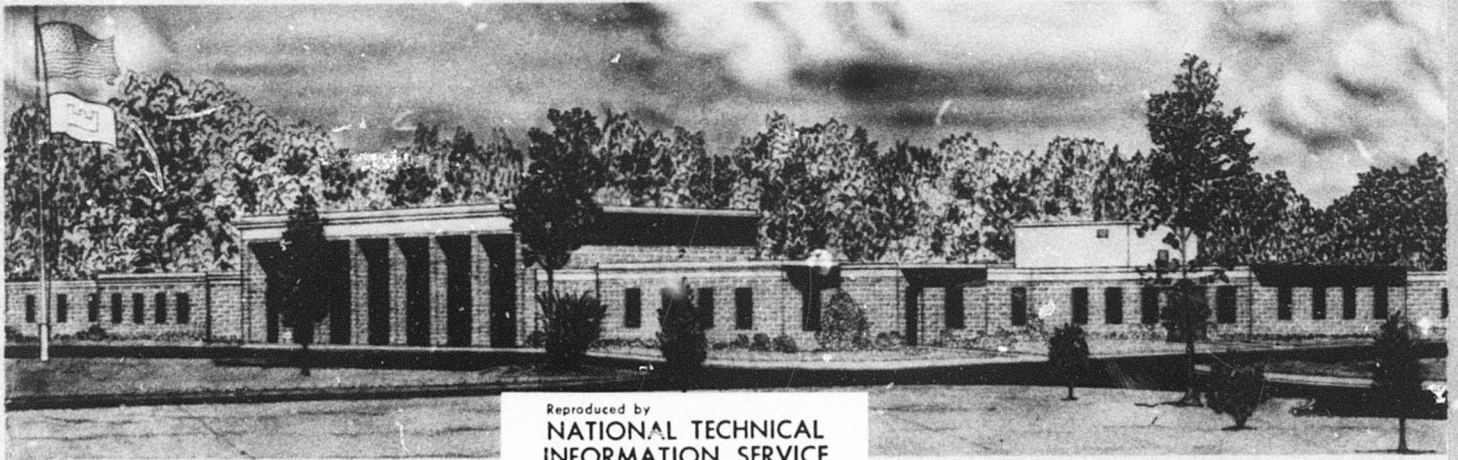

Reproduced by
NATIONAL TECHNICAL
INFORMATION SERVICE
U.S. Department of Commerce
Springfield, VA. 22151

Prepared for Office, Chief of Engineers, U. S. Army
Washington, D. C. 20314

Under Project No. 4A061101A91D

ADA 016787

Unclassified

SECURITY CLASSIFICATION OF THIS PAGE (When Data Entered)

REPORT DOCUMENTATION PAGE		READ INSTRUCTIONS BEFORE COMPLETING FORM
1. REPORT NUMBER Miscellaneous Paper 1-7-76	2. JOINT ACCESSION NO.	3. RECIPIENT'S CATALOG NUMBER
4. TITLE (and Subtitle) DESIGN AND POTENTIALS OF THE CALIFORNIUM-252 RADIATION FACILITY AT WES	5. TYPE OF REPORT & PERIOD COVERED Final report	
	6. PERFORMING ORG. REPORT NUMBER	
7. AUTHOR(s) Jack T. Lewis Ellis L. Krinitzsky	8. CONTRACT OR GRANT NUMBER(s)	
9. PERFORMING ORGANIZATION NAME AND ADDRESS U. S. Army Engineer Waterways Experiment Station Soils and Pavements Laboratory P. O. Box 631, Vicksburg, Miss. 39180	10. PROGRAM ELEMENT, PROJECT, TASK AREA & WORK UNIT NUMBERS Project 4A061101A91D	
11. CONTROLLING OFFICE NAME AND ADDRESS Office, Chief of Engineers, U. S. Army Washington, D. C. 20314	12. REPORT DATE September 1975	
	13. NUMBER OF PAGES X 68	
14. MONITORING AGENCY NAME & ADDRESS (if different from Controlling Office)	15. SECURITY CLASS. (of this report) Unclassified	
	15a. DECLASSIFICATION/DOWNGRADING SCHEDULE	
16. DISTRIBUTION STATEMENT (of this Report) Approved for public release; distribution unlimited.		
17. DISTRIBUTION STATEMENT (of the abstract entered in Block 20, if different from Report)		
18. SUPPLEMENTARY NOTES		
19. KEY WORDS (Continue on reverse side if necessary and identify by block number) Californium-252 Radiography Gamma radiation Rock properties Laboratories Soil density Neutron radiation Soil moisture		
20. ABSTRACT (Continue on reverse side if necessary and identify by block number) A facility was designed and subsequently has been built for the utilization of californium-252 in research on moisture, density, and other properties of soil and rock in relation to their engineering characteristics. Preliminary testing shows good correlations between neutron radiation and the quantification and distribution of moisture both in soil slices and in steel-encased undisturbed soil samples. Such data, when used in conjunction with X-ray studies, are valuable in furthering the knowledge and understanding of soil (Continued)		

DD FORM 1473 1 JAN 73 EDITION OF 1 NOV 65 IS OBSOLETE

Unclassified

SECURITY CLASSIFICATION OF THIS PAGE (When Data Entered)

Unclassified

SECURITY CLASSIFICATION OF THIS PAGE(When Data Entered)

20. ABSTRACT (Continued).

and rock behavior. Continued research will refine techniques for more detailed study of properties of earth materials. Detailed plans of the facility and its components are given in Appendix A.

ia

Unclassified

SECURITY CLASSIFICATION OF THIS PAGE(When Data Entered)

THE CONTENTS OF THIS REPORT ARE NOT TO BE
USED FOR ADVERTISING, PUBLICATION, OR
PROMOTIONAL PURPOSES. CITATION OF TRADE
NAMES DOES NOT CONSTITUTE AN OFFICIAL EN-
DORSEMENT OR APPROVAL OF THE USE OF SUCH
COMMERCIAL PRODUCTS.

PREFACE

This study was funded by the Office, Chief of Engineers, U. S. Army, Project No. 4A061101A91D, "In-House Laboratory Independent Research Program."

The project was conducted by Mr. Jack T. Lewis, Research Geologist, and Dr. Ellis L. Krinitzky, Chief of the Engineering Geology Research Facility, Soils and Pavements Laboratory (S&PL), U. S. Army Engineer Waterways Experiment Station (WES).

The authors are grateful to Mr. Harold Berger of Argonne National Laboratory; Messrs. Emmett Barnes, George Drucker, and Samuel Helf of U. S. Army Picatinny Arsenal; and Mr. John Antal of the U. S. Army Materials and Mechanics Research Center for making their own designs available and for their suggestions and advice during the planning stages of this project. Invaluable assistance during construction and testing phases was rendered by Drs. Ed Steele, John O. Courtney, Frank Iddings, and Robert C. McIlhenny of the Nuclear Science Center of Louisiana State University. Messrs. Jose Ballesteros, Joseph P. Wislocki, and many others of the WES Engineering and Construction Services Division were instrumental in the planning and building of the facility. Guidance in selection and design of electronic components was provided by Messrs. George P. Bonner, Burl E. Warnock, Bobby E. Reed, and others of the Instrumentation Services Division. To all of these, the authors wish to express their appreciation.

This work was done under the general direction of Mr. Don C. Banks, Chief, Engineering Geology and Rock Mechanics Division, and Mr. James P. Sale, Chief, S&PL.

Director of WES during the conduct of this study and preparation of this report was COL G. H. Hilt, CE. Technical Director was Mr. F. R. Brown.

CONTENTS

	<u>Page</u>
PREFACE	2
CONVERSION FACTORS, U. S. CUSTOMARY TO METRIC (SI) UNITS OF MEASUREMENT.	4
PART I: INTRODUCTION	5
Purpose	5
Scope	6
Properties of the Californium-252 Isotope	6
PART II: DESIGN AND CONSTRUCTION OF THE FACILITY	8
Tank and Shielding.	8
Collimators	10
Carriage for Positioning of Source.	13
Electronics and Conveyor.	15
Filter System	17
Safety Features	19
PART III: EXPERIMENTAL CAPABILITY.	20
Neutron Radiography	20
Moisture Gaging	24
PART IV: POTENTIAL DEVELOPMENTS AND APPLICATIONS	30
Developments.	30
Applications.	31
PART V: SUMMARY AND CONCLUSIONS.	33
BIBLIOGRAPHY.	36
TABLES 1-3	
APPENDIX A: DETAILED PLANS OF THE CALIFORNIUM-252 FACILITY AND COMPONENTS	
PLATES A1-A10	

CONVERSION FACTORS, U. S. CUSTOMARY TO METRIC (SI)
UNITS OF MEASUREMENT

U. S. customary units of measurement used in this report can be converted to metric (SI) units as follows:

<u>Multiply</u>	<u>By</u>	<u>To Obtain</u>
inches	2.54	centimetres
feet	0.3048	metres
cubic feet	0.02831685	cubic metres
inches per minute	2.54	centimetres per minute
pounds (mass) per cubic foot	16.01846	kilograms per cubic metre
horsepower (electric)	746	watts
electron volts	0.160210	attojoules
million electron volts	0.160210	picojoules
volts (international U. S.)	1.000338	volts
kilovolts (international U. S.)	1000.338	kilovolts
milliamperes (international U. S.)	0.999843	milliamperes
British thermal units	1055.056	joules
degrees (angle)	0.01745329	radians

DESIGN AND POTENTIALS OF THE CALIFORNIUM-252
RADIATION FACILITY AT WES

PART I: INTRODUCTION

1. In 1967, the Engineering Geology Research Facility at the U. S. Army Engineer Waterways Experiment Station (WES) began investigating the internal features of soils with the radiation from a 100-kv* X-ray tube. The work established the applicability of radiation for studying previously unseen internal features in soil and rock through radiation absorption. Since its inception, the Radiological Laboratory has acquired two additional X-ray units, a 120-kv and a 300-kv machine, for these studies. Research with x-radiography has led to the practical application of radiographic inspection to a wide variety of studies and to routine examinations of unopened cores and the selection of samples for laboratory testing. X-rays, however, are not sensitive to the moisture in soils. Yet, it is known that moisture is an important parameter in the engineering properties of soils. Neutron radiation was used to complement the X-ray studies with evaluations of moisture. Neutrons are readily moderated or attenuated by the hydrogen in water and have been used for years as moisture meters in field construction, in boreholes, and in routine moisture determinations for bulk materials in commercial processing systems. Neutrons, however, have only recently been used for studies of the engineering properties of soil and rock in the laboratory.

Purpose

2. The purpose of this study was to investigate and develop the technology, accuracy, and general applicability of neutron radiation for

* A table of factors for converting U. S. customary units of measurement to metric (SI) units is presented on page 4.

studies of soil and rock. An essential part of this effort was the development of a laboratory installation suitable for the storage and use of a neutron-emitting isotope, plus a system for the acquisition and analysis of data.

Scope

3. After extensive literature research and discussions, the californium-252 isotope (^{252}Cf) was chosen as the neutron source primarily because of the large number of neutrons emitted from a relatively small amount of material, its relatively long half-life, and the maneuverability of such a small source for the variety of soil investigations planned. This involved securing a commitment from the U. S. Atomic Energy Commission (AEC) for the loan of an appropriate source for use in research and development. WES was successful in securing a loan commitment from the AEC's Californium Demonstration Center at Louisiana State University for a 6.3- and a 3.6-mg source. This loan was obtained under the AEC Californium-252 Market Evaluation Program. A facility suitable for the housing and utilization of a californium source as large as 10 mg was designed with special effort to incorporate the advanced safety features.

Properties of the Californium-252 Isotope

4. Californium-252 has a half-life of 2.65 yr. It has a neutron emission that results mainly from the decay of the californium. Such decay is 97 percent by the emission of alpha particles and 3 percent by the spontaneous fission process that causes the emission of 2.4×10^{10} neutrons/sec from 10 mg of this material. Table 1 lists the neutrons of each energy level and their abundance per second from a 10-mg source.

5. In addition to the neutron emission, there is a total gamma radiation of 1.3×10^{11} gammas/sec from 10 mg of californium-252. These gamma rays are produced from three processes--the alpha decay process, prompt spontaneous fission of the californium, and the resulting

fission products themselves. Table 2 shows a tabulation of the gamma energy levels and the abundance of each in a 10-mg source. The most abundant source and the broadest energy spectrum of gamma rays emitted result mainly from the spontaneous fission (prompt gammas) of the californium. A less abundant gamma source of lower average energy level is produced from the resulting fission products. In addition, gammas are also produced through neutron capture and scattering in the shielding and surrounding structures. These secondary gamma energy levels are dependent upon the materials involved in the interaction and were also considered in the design; however, they cannot be represented in Table 2.

6. To utilize the maximum neutron output properly, it is necessary to shield the undesired gammas and to produce a collimated beam of the desired neutron radiation. Consideration of the basic nuclear properties was therefore a necessity in achieving the desired goals.

PART II: DESIGN AND CONSTRUCTION OF THE FACILITY

7. A shielded 6- by 6- by 12-ft-deep, water-filled tank of stainless steel was selected as the basic unit. A preliminary design was prepared which was based in large part on AEC Reports DP-1232* and DP-1246.** A later extensive review of the final WES design and proposed operating procedures included calculations of estimated dose rates at numerous points around the facility. The study concluded that by adhering to prescribed Federal regulations and the WES proposed operating procedures, there would be no radiation hazard outside of the 10- by 10-ft test area to either operating personnel or to persons in existing adjacent buildings. A plan of the general layout of the facility's components is shown in Figure 1. A brief discussion of each major component of the facility follows. Details concerning these components and the plans used to construct the facility are shown in Appendix A.

Tank and Shielding

8. The tank was constructed of 1/4-in.-thick stainless steel with the lower 6 ft being below ground surface. This lower portion serves as a storage area for the sources when not in use. The upper 6 ft has been designed for use in radiography and neutron counting. The steel tank was prefabricated in two sections. The lower 6-ft section was tested for leaks and lowered into a 7- by 7- by 6-ft-deep concrete-lined pit as shown in Figure 2. The upper 6 ft was then welded onto the lower half, and again the entire tank was leak-tested.

9. As part of the shield against radiation, a 4-in.-thick hollow wall constructed of 5/8-in.-thick plywood sheets nailed to standard

* H. E. Hootman, "Estimation of ²⁵²Cf Shielding Requirements," Research and Development Report DP-1232, 1970, U. S. Atomic Energy Commission, Savannah River Laboratory, Aiken, S. C.

** D. H. Stoddard and H. E. Hootman, "252 Cf Shielding Guide," Research and Development Report DP-1246, 1971, U. S. Atomic Energy Commission, Savannah River Laboratory, Aiken, S. C.

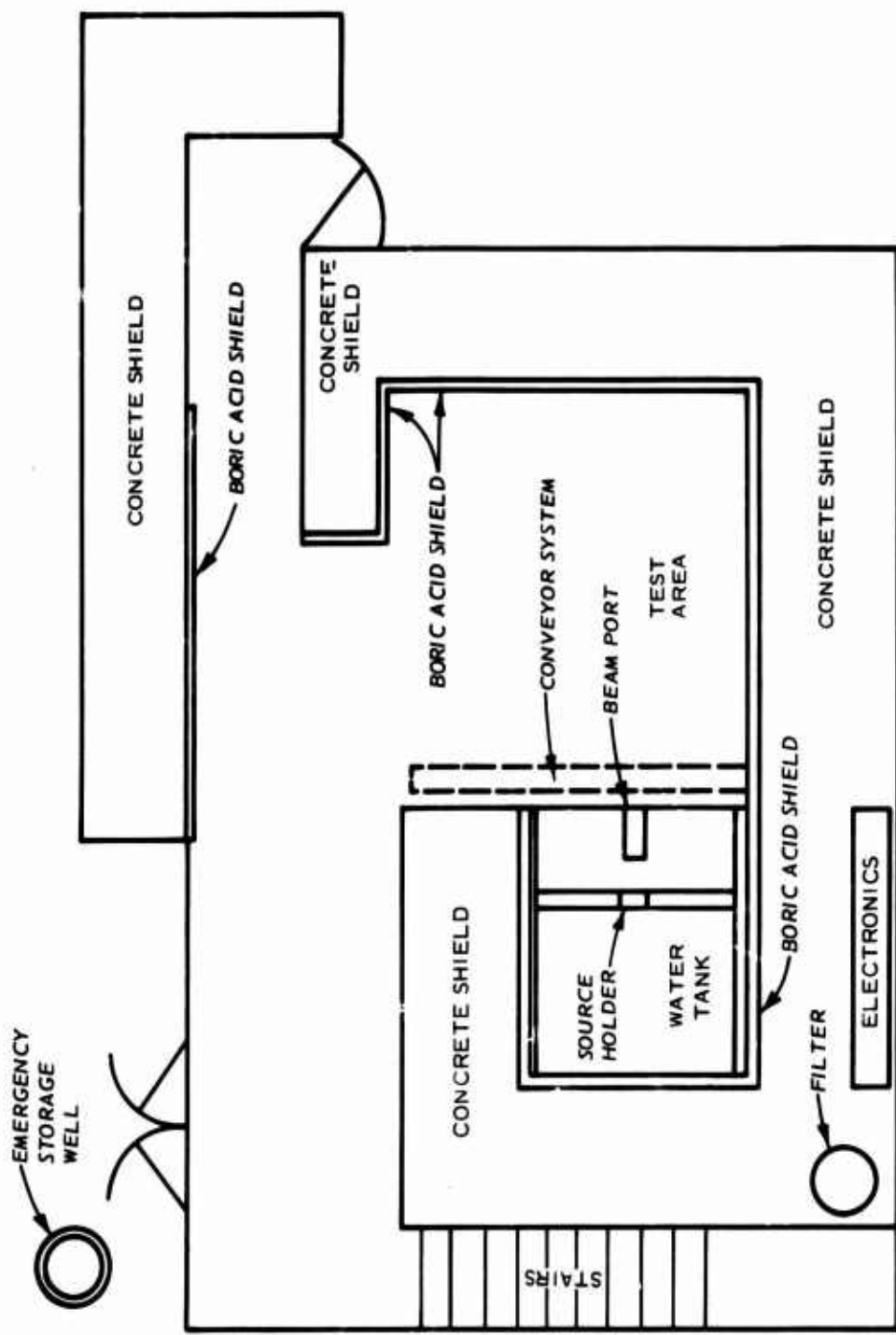

Figure 1. Plan of tank and test area

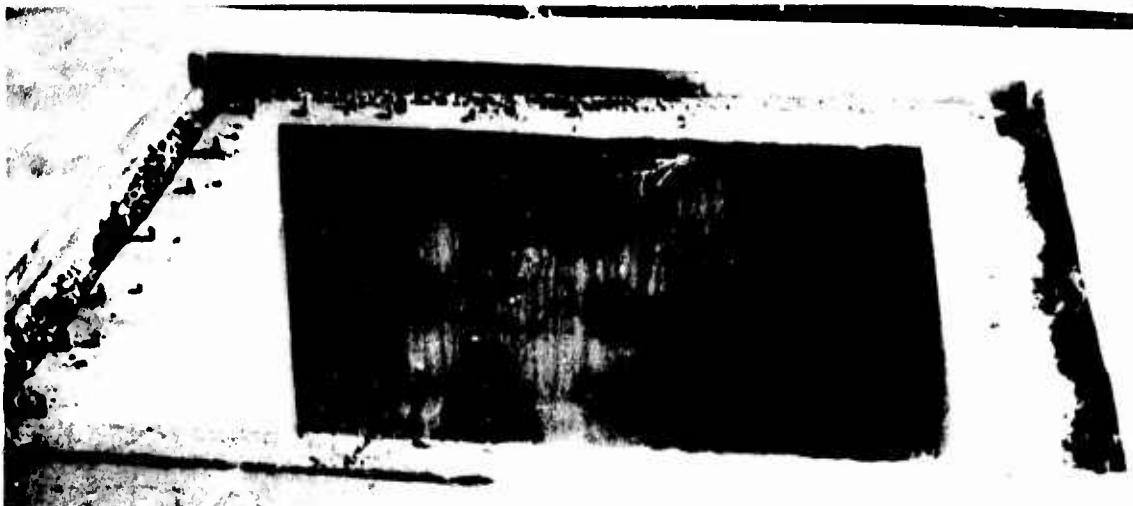

Figure 2. View of concrete-lined foundation for tank

2- by 4-in. wood braces was filled with granular boric acid. This wall was built adjacent to three sides of the steel tank and acts as a shield for capturing neutrons escaping from the tank. Interaction of the neutrons with the boron, however, creates additional gamma radiation. This gamma radiation and 2.2-Mev gammas resulting from the hydrogen capture of neutrons in the water, plus those from fission of the californium itself, require further shielding. It was necessary that a 36-in.-thick wall of solid, high-density concrete blocks sufficient to absorb this energy also be built. Granular boric acid was spread over each course of layered block (Figure 3) and brushed to fill joints. This concrete wall surrounds three sides of the tank. A 10- by 10-ft floor space in front of the unshielded face of the tank serves as the test area. The outer perimeter of this area is also surrounded by the extension of the boric acid and concrete walls. Figure 4 shows the completed exterior wall of the massive concrete block shielding.

Collimators

10. Several special design features were essential to utilize a particular portion of the radiation available from the californium-252. It is necessary to shield other undesired radiation. As an example, to make a thermal neutron radiograph of the moisture distribution in a soil,



Figure 3. Early stage of constructing shield around tank. Note courses of stacked blocks with boric acid placed to fill joints. Plywood in center holds a 4-in.-thick vertical wall of boric acid

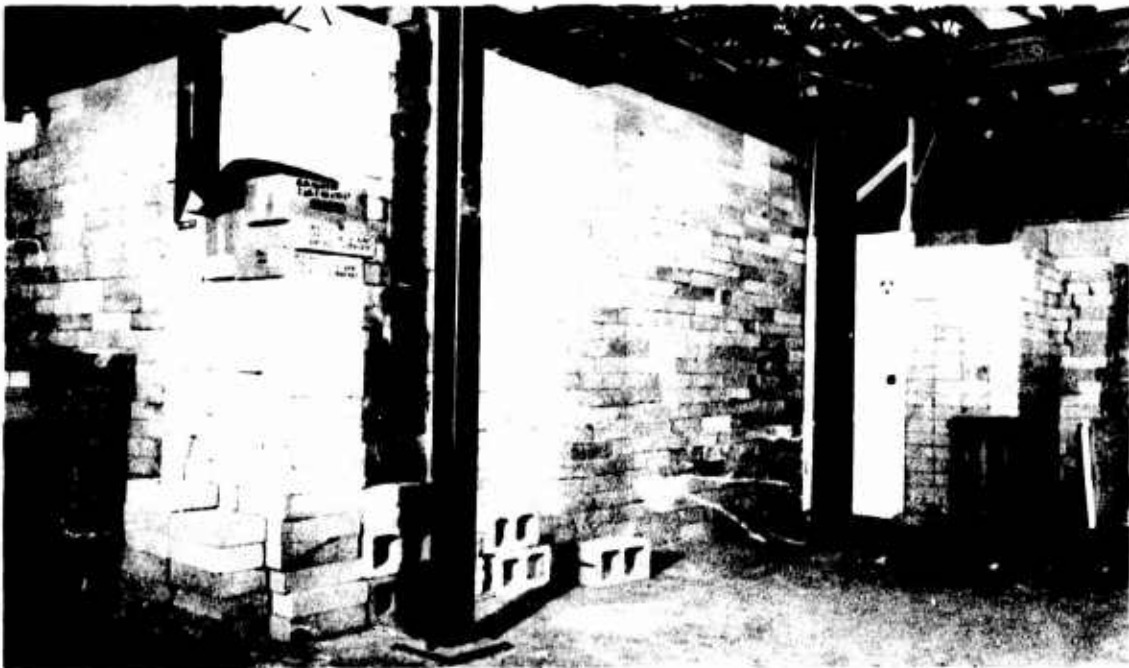

Figure 4. Exterior view of shielded test area

a maximum thermal neutron flux with energy levels of about 0.025 ev was desired. Thermalization (slowing down) of the higher energy neutrons was required plus the minimization of the gamma radiation in order to achieve the desired results. The water-filled tank was therefore selected not only for shielding of the neutrons but also for thermalizing of the fast neutrons from the californium source by a suitable interval of water.

11. To allow a controlled beam of neutrons from the tank into the test area, it was necessary to provide an 8-in.-diam port in the tank face. The port was necessary since the stainless steel caused considerable scattering of the thermal neutrons as they passed through the tank wall. A 1/8-in.-thick-walled, 6-in.-diam, and 14-in.-long, aluminum, watertight cylinder was bolted into the tank hole, thus allowing the aluminum cylinder, which is relatively transparent to neutrons, to project into the water shield as shown in Figure 5 (upper view of tank).

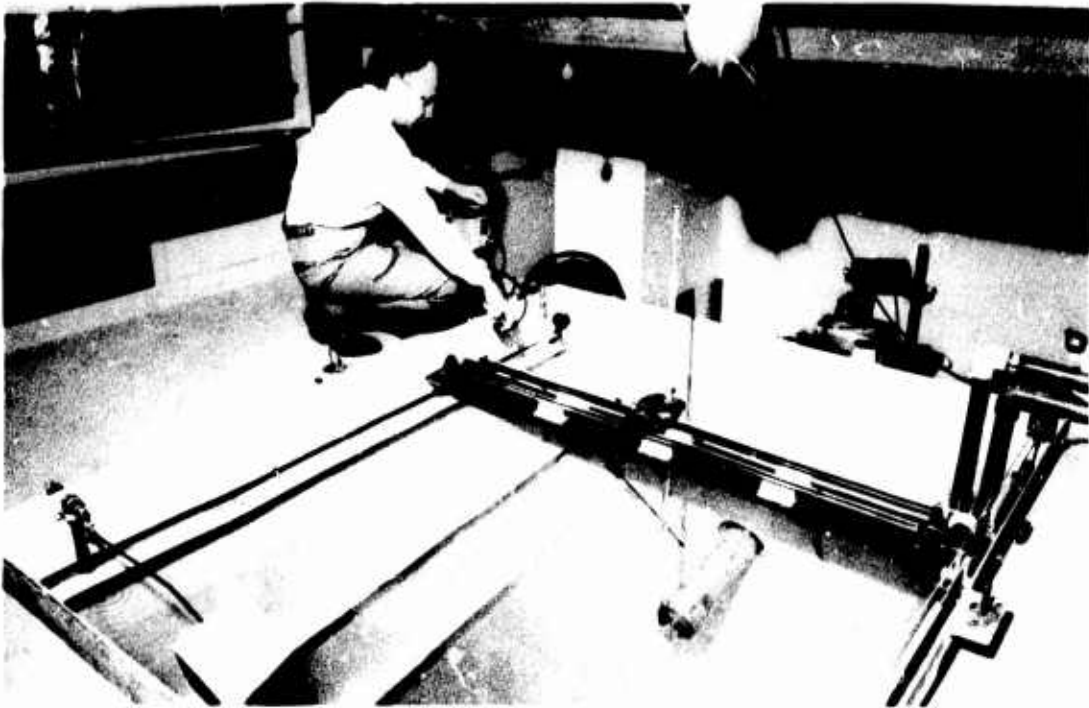

Figure 5. Upper view of WES neutron water tank and source positioning apparatus

A collimator, constructed of a 6-in.-diam, borated, water-extended polyester (WEP) cylinder, the inside of which is conical shaped, was built to

be inserted into the aluminum housing. The front end of the collimator has a 5-in.-diam opening which tapers to a 2-in.-diam opening at the rear end. A 0.020-in.-thick conical sheet of cadmium is sandwiched between the WEP inner face and a lead cone having 1/4-in.-thick walls. A 2-in.-thick block of bismuth is located in the rear of the collimator to minimize the gamma radiation from fission of the californium. Three feet of shield water is maintained above the collimator during tests. The collimator is a somewhat modified version of the one designed by Barnes et al. at Picatinny Arsenal.*

12. The collimator, shown in Figure 6, was designed to allow

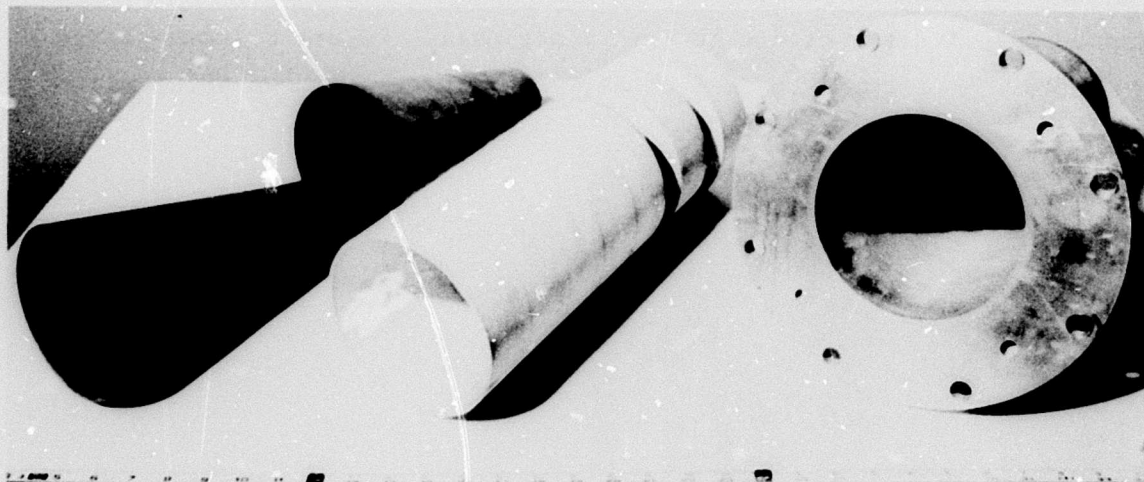

Figure 6. Front view of collimator used in neutron radiography and moisture gaging

neutron thermalization, plus some absorption of the undesired gammas for neutron radiography. Such shielding reduces the gamma content to tolerable quantities although they are never removed entirely.

Carriage for Positioning of Source

13. A two-directional carriage with a vertical plastic

* E. G. Barnes et al., "An Experimental Neutron Radiography System Using Californium 252," Technical Report 4629, Mar 1974, Picatinny Arsenal, Dover, N. J.

source-holding rod allows the positioning and movement in the tank. A typical setup with the source in the radiographing position is shown in Figure 5. At the end of the plastic rod is a 1-in.-thick by 2-3/4-in.-long by 2-1/4-in.-high plastic block. Two 1-1/2-in.-deep holes, each slightly larger than the diameter of one of the sources (3/8 in. in diameter), were drilled from the bottom of the block. Two other holes, approximately 1/8 in. in diameter, were drilled from the top of the block. The above design allows each of the sources to be raised and secured in the two positioning holes with a nylon braided line. The sources can then be moved to any position within a horizontal plane with the two-directional carriage. Repositioning the sources for repeatable exposures, if desired, can be easily achieved. Figure 7 shows photographs of the plastic rod and block. One source is shown being pulled

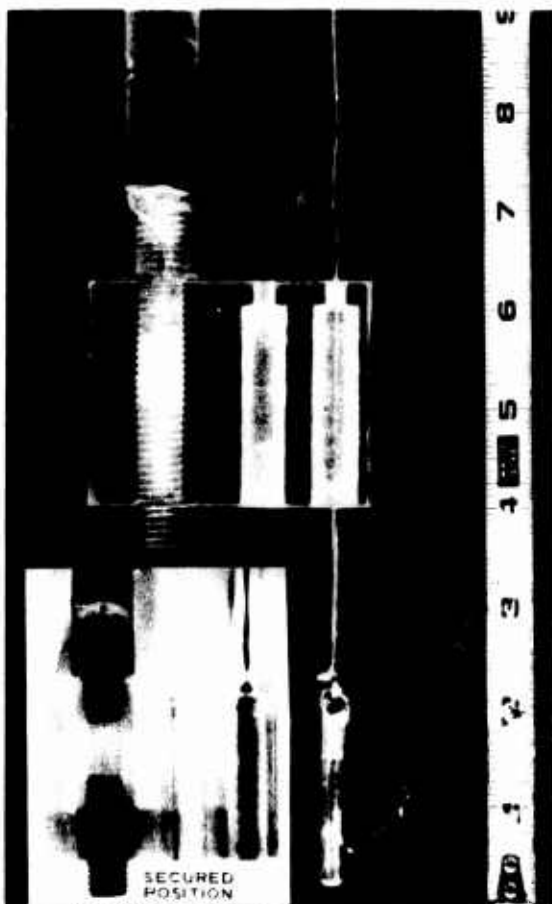

Figure 7. Plastic source-holding block at end of vertical rod. SRCf-181 dummy source is shown suspended below. This is pulled upward and locked

into position for test purposes. The inset shows the source in a secured position. Figure 8 shows a schematic diagram of the positioning carriage.

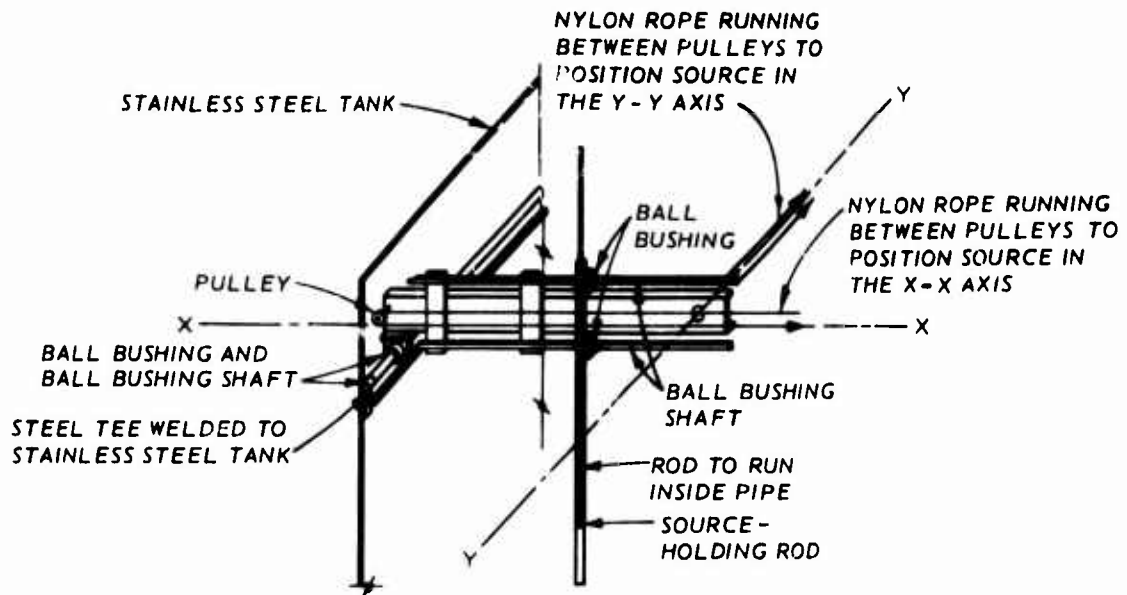
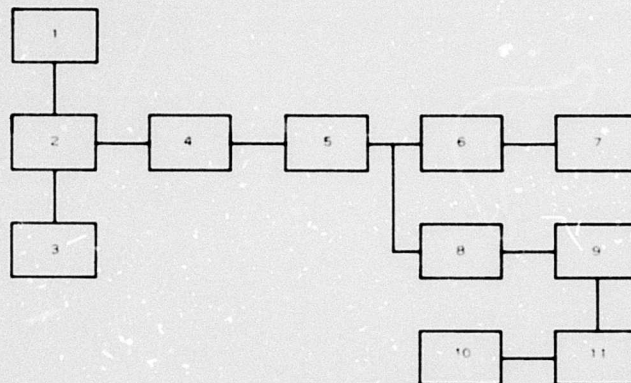

Figure 8. Schematic of mechanism to position source in horizontal plane

Electronics and Conveyor

14. Experimentation with direct quantitative moisture determinations along thin soil layers necessitated the purchase of several pieces of electronic equipment. This equipment included a suitable detector and the accompanying electronic counting and plotting components shown diagrammatically in Figure 9.

15. For quantitative moisture determination, a procedure different from that used in radiography was necessary. Since fast neutrons are attenuated by the hydrogen atom, it was desirable to detect and record the variation produced in the thermal neutrons in counts per minute (CPM) when a sample was bombarded with a beam of fast neutrons. Since the CPM-1 is proportional to the moisture content in a sample, a CPM-1 moisture content calibration curve can be prepared from standard soil samples of known moisture. This curve can then be used for determining the moisture



- | | |
|---|--|
| <p>1. HIGH VOLTAGE POWER SUPPLY - SUPPLIES \approx 3000 VOLTS TO ACTIVATE DETECTOR</p> <p>2. CHARGE-SENSITIVE PRE-AMPLIFIER - PROVIDES CHARGE TO VOLTAGE CONVERSION AND IMPEDANCE MATCHING</p> <p>3. DETECTOR - PROVIDES OUTPUT SIGNAL PROPORTIONAL TO RADIATION LEVEL</p> <p>4. LINEAR AMPLIFIER - PROVIDES VOLTAGE GAIN AND PULSE SHAPING NETWORK</p> <p>5. SINGLE CHANNEL ANALYZER - CONSISTS OF TWO DISCRIMINATORS, THE SETTINGS OF WHICH DEFINE THE REGION OF THE OUTPUT SIGNAL</p> | <p>6. SCALER - PROVIDES VISUAL COUNT DISPLAY OVER THE RANGE OF THE ANALYZER</p> <p>7. TIMER - GATES THE SCALER FOR PREDETERMINED TIME INTERVALS</p> <p>8. RATE METER - PROVIDES VISUAL DISPLAY IN UNITS OF COUNTS PER SECOND</p> <p>9. LOW PASS - ACTIVE FILTER - FILTERS OUT UNDESIRABLE HIGH FREQUENCY SIGNALS RESULTING FROM HIGH GAIN, ALSO LIMITS COUNT LEVEL</p> <p>10. SAMPLE POSITION CONTROLLER - MOVES SAMPLE ACROSS DETECTOR AT A DESIRED RATE</p> <p>11. X-Y RECORDER - PROVIDES PLOT OF COUNTS PER SECOND VS. SAMPLE POSITION</p> |
|---|--|

Figure 9. Diagram of electronic system for neutron counting and plotting

in an unknown sample through a CPM of thermal neutrons produced from bombardment by a fast neutron beam. The principle utilized in moisture gaging with neutron sources has been described and reported by Helf in a report presented in 1972.*

16. Initial research was therefore directed toward determining moisture content through a neutron scan of a soil core encased in a 3-in.-diam standard steel sampling tube. Scanning required the capability to move a sample through a narrow neutron beam and at the same time record the desired data on an X-Y plotter. A small roller type conveyor with an electronic-controlled activator drives a sample horizontally across the beam at speeds of as low as 0.2 in./min. Thermal

* S. Helf, "Neutron Gauging Applications Using a Small 252 Cf Source," ANS Special Topics Symposium on Applications of 252 Cf, Nov 1972, Austin, Tex.; Feltman Research Laboratory, Picatinny Arsenal, Dover, N. J.

neutron CPM resulting from scattering of the beam by the moisture are automatically detected and recorded on the X-Y plotter. This plotter and the conveyor are synchronized for a 1:1 printout, thus producing a graphic log of the variation in CPM and moisture content. Figure 10

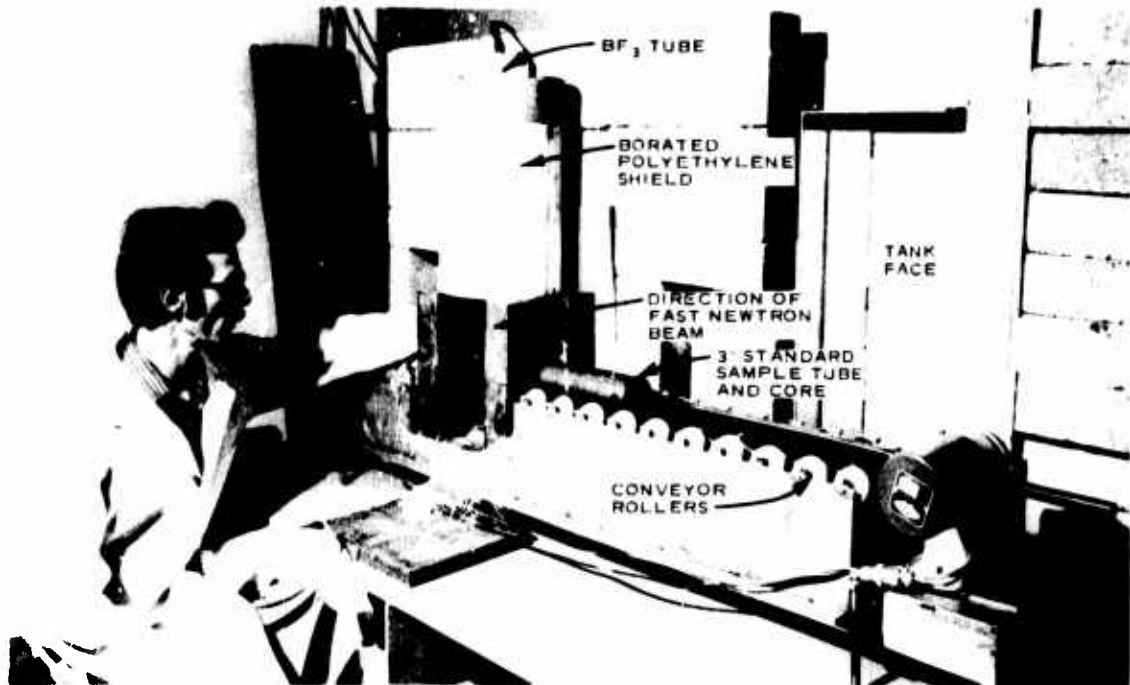

Figure 10. Typical moisture gaging setup. Note vertically oriented detector and horizontal driving mechanism used in scanning steel-encased soil sample

shows a typical conveyor scanning operation for a 36-in.-long, 3-in.-diam steel-encased soil core.

Filter System

17. An additional component of the facility is a filtering system which was installed in order to demineralize the tap water used for the neutron shield. Changes caused by irradiating suspended particles in the water which could possibly lead to unnecessary additional background radiation are minimized in demineralized water. Water is circulated from the lower one-third of the tank and carried by a 2-in. PVC pipe to the

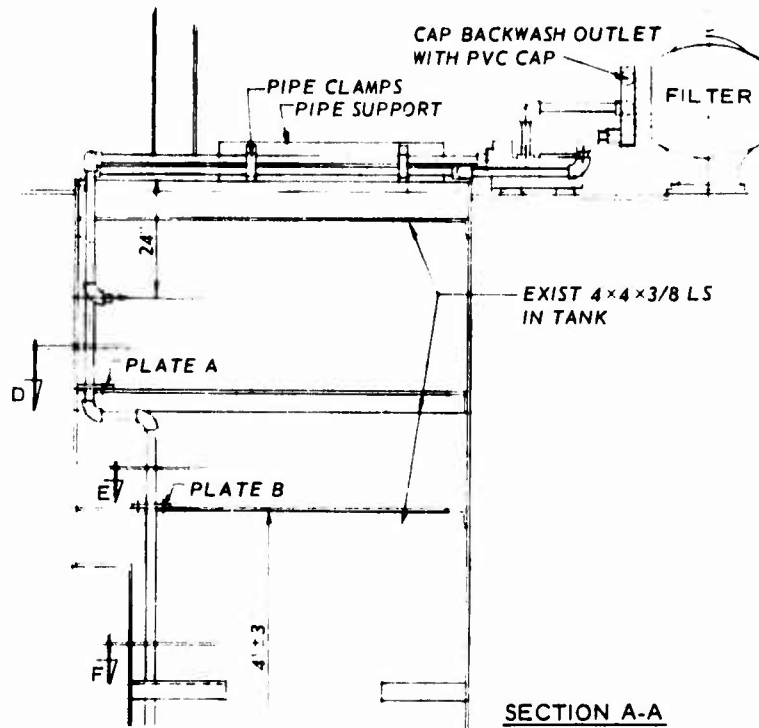
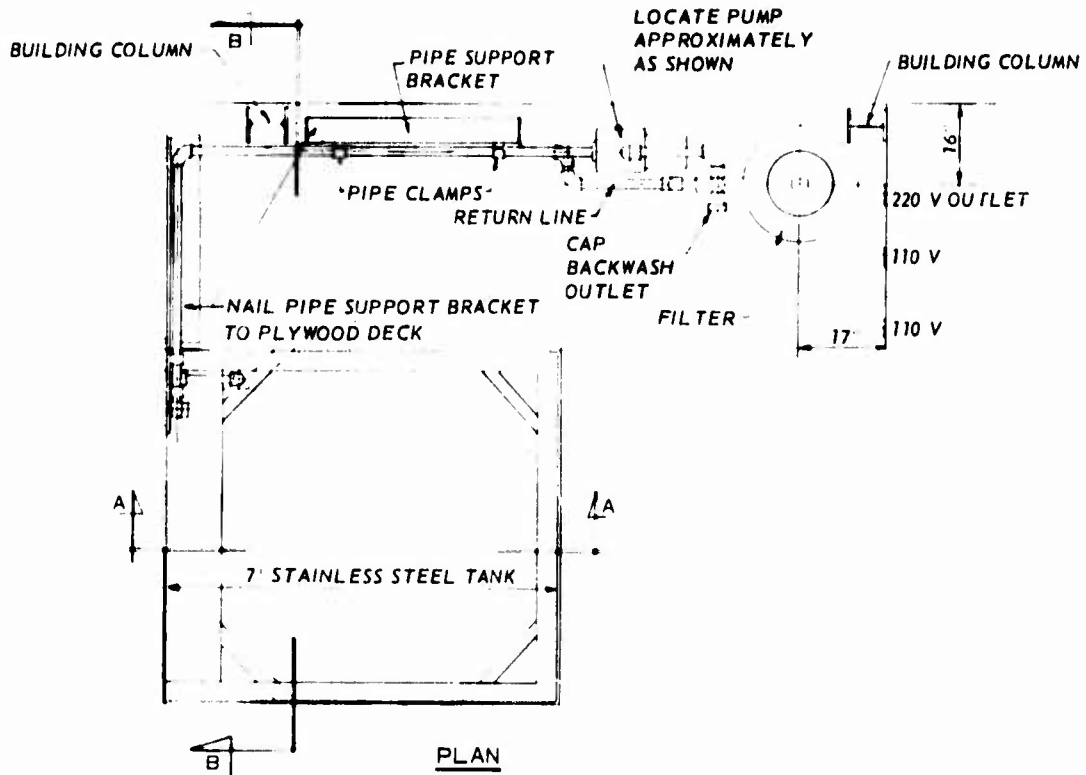

Figure 11. Water filtering system

filter. It is there passed through approximately 2 cu ft of an ion exchange type filter (Permutit M-101 resin), and then through 1 cu ft of a sand filter before being returned to the tank.

18. To avoid corrosive action on metals by the demineralized water, the system is equipped with plastic pipe, a fiberglass filter housing, and a corrosion-resistant 1-hp pump. The tank itself is coated with two layers of epoxy. A bypass valve installed in the tank return line allows for lowering the tank water level to change the collimator whenever necessary. Such changes require no more than 2 hr for lowering and refilling. Figure 11 shows a drawing of the water filtering system.

Safety Features

19. Because of the hazardous nature of the tests involved, several safety devices were also installed. The devices include a bell alarm system that activates when either a loss of water (shielding) or an increase in radiation occurs. Figure 5 shows the top view of the tank and the radiation detector (upper center). A red warning light automatically turns on when neutron radiation is present in the test area. Access to the test area is only through positive lock controlled doors.

PART III: EXPERIMENTAL CAPABILITY

20. Development was directed along two lines for utilization of the neutron capability, namely, Neutron Radiography and Quantitative Moisture Gaging. It was necessary that certain modifications in approach and in accessory equipment be made in each area of study. These two areas of study are described separately.

Neutron Radiography

21. Radiography as referred to in this report is essentially the producing of an image on film which will result from the differential absorption of the neutrons in the test material. In the case of most soils the most common element present with a high mass-absorption coefficient for thermal neutrons is hydrogen. Consequently, a film showing zones of high thermal neutron absorption in a soil generally indicates the presence of hydrogen. These zones occur primarily as the result of the hydrogen constituent in the soil pore water although in some cases organic matter in the soil or water of crystallization may produce such zones. The absorption in radiography will result in a film image showing the relative distribution of moisture in the sample.

22. Several avenues were investigated at the outset to determine the best equipment and procedures to use to achieve the most reliable image. All methods utilized a direct conversion screen for producing these radiographs. This involves the use of a thermal neutron-sensitive screen capable of emitting either low-energy X-rays or light when bombarded by thermal neutrons. The production and intensity of such secondary radiation are dependent upon the quantity of thermal neutrons able to penetrate the moisture and bombard the screen. The penetration of such thermal neutrons is therefore a function of the quantity of moisture present in the sample being radiographed. Three different screens were used in the experiments to determine the highest quality of radiographic image produced. These consisted of:

- a. A 3-1/4- by 4-1/4-in. lithium iodide-zinc sulfide scintillation screen.
- b. A 4- by 5- by 0.001-in.-thick gadolinium metal foil.
- c. A 14- by 17-in. sapphire-coated, vapor-phase-deposited gadolinium on a polished aluminum plate.

23. Experiments with the three screens, utilizing Kodak type AA, M, and single emulsion type R film, were conducted to determine the best combination for detailed study of soil moisture distribution. It was required that capabilities be such as to produce a 14- by 17-in. image of the sample being radiographed.

24. The scintillation screen provided lower exposure time, but lacked some of the desired detail. The gadolinium foil produced the best image, although a considerably longer exposure time was required. Limits on sizes of gadolinium foil available, however, necessitated the final purchase of a 14- by 17-in. vapor-phase-deposited gadolinium screen. This screen has produced the best images to date with a single emulsion Kodak type R film. Such exposures, however, require up to 16 hr for 3/8-in.-thick samples, or even more when thicknesses are as great as 3 in. in diameter. This exposure time can be reduced somewhat by using faster but slightly more grainy film such as Kodak type AA. One undesirable feature, however, is that AA film is more sensitive to exposure from gamma radiation.

25. Early radiographic experiments dealt primarily with 3/8-in.-thick soil samples wrapped in aluminum foil. Good results were obtained by using a gadolinium foil screen, a type R film, only one source (3.6 mg), and a source-to-film distance of 30 in. The source was centered 1 in. from the rear of the collimator for a 16-hr exposure. Figure 12 shows a comparison of neutron and x-radiographs. The reversal of absorption characteristics is evident in some zones. The light area (1) in the X-radiograph is a zone of high film density and generally indicates a zone of low soil density. This same zone (2) (darker in the neutron radiograph) shows a high absorption of neutrons and thus a high moisture content.

26. Figure 13 is another example of 3/8-in.-thick soil



Figure 12. Comparison of X-ray and neutron absorption in 3/8-in.-thick soil slab

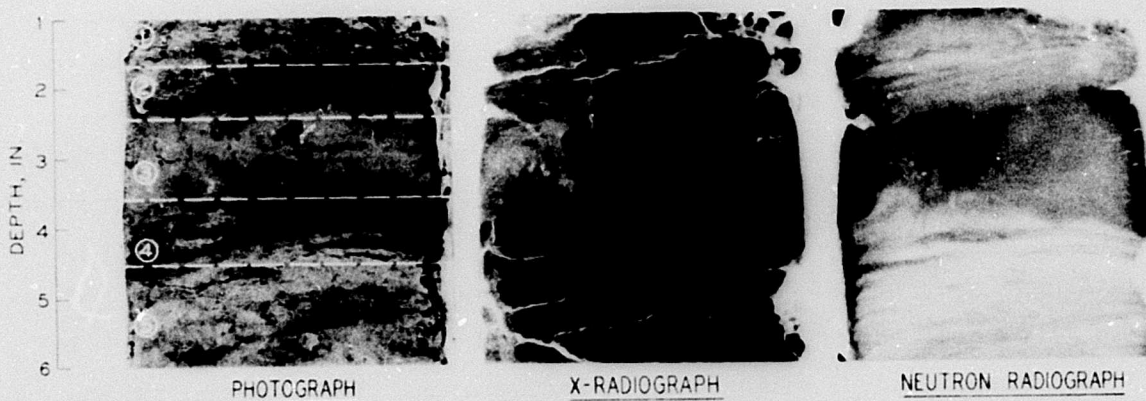

LEGEND

<u>SOIL DESCRIPTION</u>	<u>WATER CONTENT %</u>	<u>AVERAGE FILM DENSITY</u>
① SILT (ML) WITH TRACE OF SAND AND FINE ORGANIC MATTER	22.2	-
② SILTY CLAY (CL), 50% SAND AND 50% CLAY	32.2	0.80
③ CLAY (CH), VERY PLASTIC	65.2	0.72
④ SILTY CLAY (CL), 50% SAND AND 50% CLAY	46.8	0.77
⑤ SILT (ML), WITH TRACE OF FINE SAND	20.0	0.84

Figure 13. Photograph and radiographs of 3/8-in.-thick soil sample

radiographs. Laboratory-determined moisture contents shown in the figure were plotted for correlation purposes against an average film density for the corresponding zone. This moisture-film density curve is illustrated in Figure 14 and shows a good correlation between the two parameters.

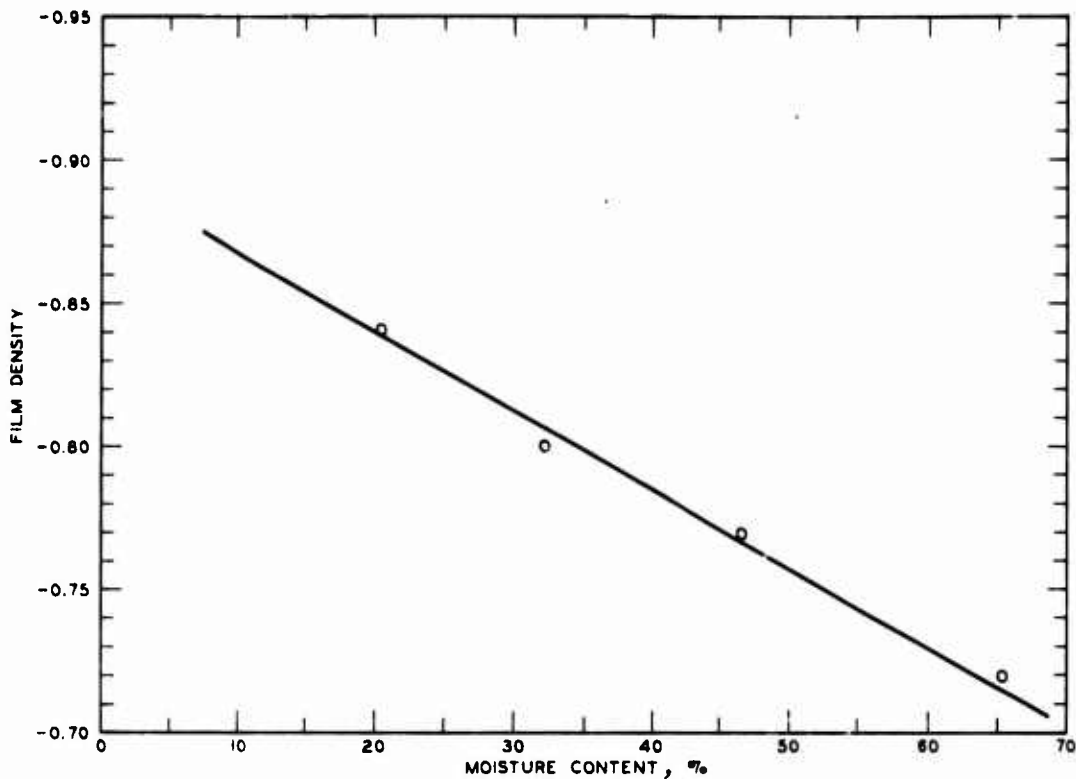

Figure 14. Film density versus moisture content from 3/8-in.-thick soil sample

27. Other radiographic experiments dealt with unopened soil cores. This first involved the preparation of a series of laboratory soil standards for use as references to known properties. Each standard was compacted in 3-in.-diam by 12-in.-long shelby tubes. The steel tube wall thicknesses are approximately 1/8 in. The moisture content, wet density, and dry density were determined for each during preparation. The samples were sealed to prevent moisture evaporation. Table 3 gives the engineering properties of each tube established as a standard for these radiographic experiments.

28. Neutron and x-radiographs were made of each of the above standards for comparison of variations in images caused by the absorption

of the two types of radiation. A comparison is shown in Figure 15. The x-radiograph was made on Kodak type M film, at a focal distance of 10 ft, 250 kv, 10 ma, and for exposure lasting 3 min. The neutron radiograph was made with Kodak type R (single emulsion) film, with a source-to-film distance of 40 in. (L:D ratio 20),* a source-to-rear-of-collimator distance of 1 in., and a 16-hr exposure time.

29. An analysis of some of the neutron radiographic images of the soil standards, using an Image Quality Indicator (IQI) and also a Beam Purity Indicator (BPI),** shows a relatively good thermal and epithermal neutron contribution. Some gamma radiation is present, however, but apparently is of little film contribution. Such gamma contribution was lowest when using the less gamma-sensitive film such as Kodak single-emulsion type R.

30. The experiments with the standards and several unknown samples show that neutron radiography does have considerable applicability to soil studies. Variations in moisture content and its distribution can be located and identified with no difficulty in thin (3/8-in.-thick) soil slabs. Quantification of this moisture content through controlled film density measurements also is feasible in the thin soil sections. Further research, however, must be performed before the correlation of these film densities versus moisture content of thicker samples, such as in a 3-in. steel-encased soil standard, can be established.

Moisture Gaging

31. Direct moisture gaging experiments were conducted primarily for studying the applicability of existing techniques for quantitative gaging of moisture along thin discrete soil layers. Research with neutrons by others has demonstrated the use of fast and thermal neutrons in bulk moisture determination on soils and canned foods.

32. Several approaches were considered in this project prior to

* L = distance from rear of collimator to film, D = diameter of small opening of collimator.

** Beam Purity Indicator currently under study by ASTM committee E705.



X-RADIOGRAPH
KODAK TYPE M FILM



A
(3.2% H₂O)

B
(9.3% H₂O)

NEUTRON RADIOGRAPH
KODAK TYPE R (SINGLE-COATED) FILM

Figure 15. Comparison of x- and neutron radiographs of standard soil samples

determining the most applicable method for the moisture gaging studies. The first experiments subjected the soil standards to a fast neutron beam. Bombardment of the standards with fast neutrons produced two possible methods for moisture gaging. Many of the fast neutrons were absorbed by the moisture in the sample. At the same time thermal neutrons from scattering were produced by the collision of neutrons with hydrogen atoms in the soil pore water. Consideration of both methods led to the decision to concentrate on the thermal neutron detection method in which a neutron flux will increase in proportion to an increase in moisture in a sample being bombarded with a fast neutron beam. A count of the thermal neutrons from a fast neutron beam bombarding a sample with no moisture can first be recorded. Any additional count of thermal neutrons from a sample containing moisture is a result of thermalization of fast neutrons by collisions with the hydrogen atoms in the water. Since such scattered neutrons are being emitted in every direction (spherical), the detector can be placed at a 90-deg position to the fast beam, thus avoiding excessive undesired radiation in the path of the beam.

33. The soil standards were bombarded with a fast neutron beam and monitored to prepare a calibration curve of thermal neutron CPM versus the actual laboratory-determined moisture contents for the standards. Figure 16 shows one of many curves prepared during experiments to determine optimum CPM with relation to the location of ^{252}Cf in the tank. By reading the thermal neutron CPM of an unknown sample of the same size as the standard being bombarded by a fast neutron beam, the percent moisture present can be determined from the calibration curve.

34. To concentrate on a thin soil layer, it was necessary to shield all but a small opening for passage of the fast beam and also for the detection of the scattered neutrons. This procedure consisted of reversing the collimator in the housing with the 2-in.-diam opening being placed at the front. A 2-in.-thick borated WEP disk was placed in front of the collimator. A 1/4-in.-wide by 2-in. vertical slit was cut from the center of the 2-in.-thick disk to allow a somewhat more restricted fast neutron beam to bombard the sample. The thermal

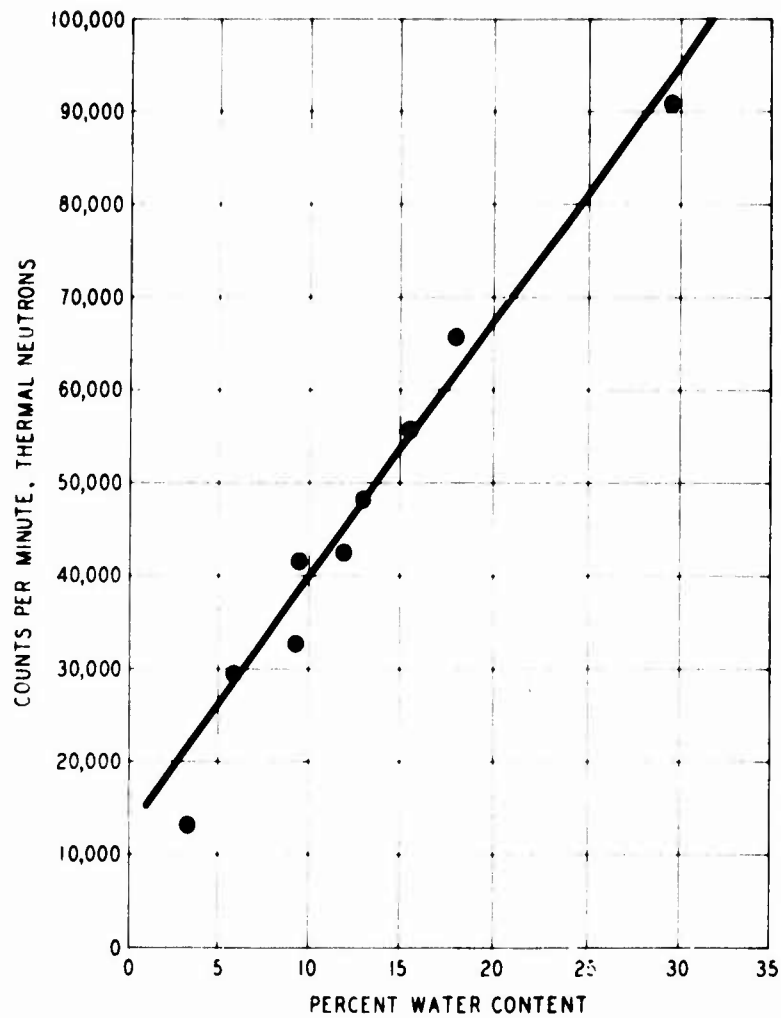

Figure 16. Calibration curve determined from soil standards.

neutrons produced by scattering were then detected with the boron trifluoride (BF_3) tube located 90 deg from the beam as shown in Figure 10.

35. For a typical scan of an unknown sample, a calibration curve prepared from the standards is first recorded and automatically plotted on an X-Y plotter for reference. It is necessary that both the unknown sample and the standards used for calibration be of the same thickness and in similar containers.

36. The sample with an unknown moisture content was then moved across the fast neutron beam. The BF_3 detector counted the thermalized neutrons and automatically plotted the CPM on the X-Y plotter. The

speed of the conveyor and the plotter was synchronized for a 1:1 print-out on the plotter. Figure 17 is an example of one scan of an unknown sample, along with corresponding neutron and x-radiographs. A quick reference at any CPM on the graphic log will provide a corresponding moisture content for that point based on the standard calibration curve.

37. Laboratory test data of the samples investigated to date indicate that the accuracy of such scans can be refined to an acceptable degree for moisture determinations of the thin layers desired. Further refinement, however, of this method must be carried out to achieve this goal. All experiments show definite correlation between CPM of the thermal neutrons detected and the actual moisture content.



Figure 17. Radiographs of steel-encased 3-in.-diam soil sample. Graphic illustration at right was determined through neutron scan of core

PART IV: POTENTIAL DEVELOPMENTS AND APPLICATIONS

38. A capability has been demonstrated for quantitative moisture determination in earth materials. Thus far, two procedures are available--radiographic imaging and neutron counting.

Developments

39. There are two problems in working with neutron radiographs--the very long time needed for exposures, often 16 hr and longer, and the contribution of gamma radiation in the neutron image.

40. The problem with excessive exposure time may be resolved by two possible means:

- a. Image intensification. Instead of registering an image directly on film using screens, the image may be processed through an image intensifier. This device allows a neutron-generated image to excite electrons on a sensitive plate. The electrons are accelerated in a magnetic field and register a stronger image on a fluorescent viewing screen. A further accentuation of the image can be made on a TV screen by electronically superimposing and summing repeated images. Such a system will allow direct viewing and rapid interpretation of specimens.
- b. The Californium Multiplier. Techniques are under development whereby the californium-252 may be brought into a subcritical uranium assembly in which it will initiate a chain of fission events that will generate additional neutrons. Such an assembly is probably capable of boosting neutrons emissions by several tens of times. This temporarily enhanced neutron radiation may make quick images possible with current film and screen techniques or it may be used with image intensification devices.

41. Gamma radiation also is a solvable problem. Preceding sections of the report have shown how gamma radiation can be mitigated through shielding. Although it can never be removed altogether, techniques may be developed whereby gamma effects are measured and then removed from the image by a subtraction process.

42. An area that has not yet been mentioned is that of neutron activation analysis. This area is a logical extension of the present

installation through neutron bombardment of a sample whereby secondary gammas are emitted. These gammas have spectral components which are determined by the chemical elements that generate them; thus, they provide signatures for the component parts of the sample and may be summed to provide a quantitative assessment.

43. Density of a sample may be assessed either by monitoring the secondary gammas that are emitted after neutron bombardment or by measuring the absorption of primary or secondary gammas radiated from the californium tank. The possibility exists that the tracking system for examination of undisturbed cores may provide simultaneously a soil-density and a moisture profile.

Applications

44. The californium-252 source has applications in the following areas:

- a. Examining patterns of moisture inhomogeneities in materials.
- b. Quantifying the presence of moisture nondestructively.
- c. Monitoring the density of materials.
- d. Examining the chemical composition of materials.

45. A few possible problems that may be studied with this new capability are:

- a. The movement of fluids in models.
- b. Mobilization of moisture during shear, swelling, ballistic penetration, etc.
- c. Improved moisture and density values for soil liquefaction studies.
- d. Determination of incipient cementation of sands by iron, calcium, and magnesium, or of incipient carbonate cementation in clays.
- e. Assessment of stabilization chemicals in soils.

46. Improved capabilities with both X-ray and neutron imagery may provide spectrally selected images of secondary gamma emission which would be, in effect, pictures of the relative abundance of specific chemical elements in a sample.

47. Another area for further improvements is in three-dimensional imagery with the possibility that pseudoholograms may be produced of penetrating radiation by conversion to lasers.

PART V: SUMMARY AND CONCLUSIONS

48. The purpose of this study was to investigate and develop the technology for assessing the accuracy and general applicability of neutron radiation for detailed studies of soil and rock. An essential part of this effort was the development of a laboratory installation suitable for the storage and use of a neutron-emitting isotope.

49. Earlier studies of the internal features of soil and rock at WES were conducted with X-rays. These studies led to the development of techniques and procedures to provide detailed knowledge of the effects that such features have upon engineering properties of soils. These earlier studies, however, dealt primarily with variations as reflected by the absorption of X-rays. X-rays, however, are relatively insensitive to moisture in soils. Yet it is known that moisture also is an important parameter in the engineering properties of soils. It was deemed necessary, therefore, to complement the detailed X-ray studies with neutron studies of moisture distribution in soils. Neutrons are readily moderated or attenuated by hydrogen in water and as such have been used for many years in bulk sample moisture determinations.

50. In 1974 WES acquired approximately 10 mg of californium-252 for use in these more detailed nondestructive moisture studies. This isotopic source was selected primarily because of the relatively large number of neutrons emitted (2.3×10^{10} neutrons/sec/10 mg), its small size (3/8 in. in diameter by 1-1/2 in. long), and its relatively long half-life of 2.65 yr.

51. A 6- by 6- by 12-ft-deep, water-filled, stainless steel tank was constructed for housing the californium source. Three sides of the tank were shielded with 4 in. of boric acid and 36 in. of concrete. A 10- by 10-ft test area immediately in front of the fourth side was used for neutron radiography and moisture gaging. This area was also shielded with boric acid and concrete.

52. Two goals are of primary importance. They are the developing of techniques for preparing neutron radiographs of moisture distribution and the instrumentation of nondestructive moisture gaging of soils.

53. For testing purposes the sources are raised to a three-dimensional carriage and positioned at the rear of a 14-in.-long by 6-in.-diam collimating tube of aluminum. Depending upon the test to be conducted, whether radiography or gaging, a collimator is inserted into the open end of the tube to produce the desired beam. This insert consists of a 6-in.-diam by 14-in.-long cylinder having an inner conical shape. Soil samples, some of which measure up to 3 in. in diameter, are enclosed in steel-walled sample tubes and are radiographed to determine internal moisture distribution.

54. For radiographing specimens, a direct conversion screen is placed next to the film in the film holder for exposure. Length of exposure time varies considerably, depending upon the thickness of sample. Generally a 16-hr exposure with Kodak AA film produces a good image. Longer exposures with Kodak single-emulsion type R film, however, have proved to give the best neutron image.

55. In assessing the accuracy of moisture gaging by scanning the longitudinal axis of 3-in.-diam steel-encased soil cores, the system utilizes a small conveyor and drive mechanism for moving 3-in. tubes and samples through a beam of fast neutrons. A BF_3 detector, located at 90 deg to the beam, detects an increase in thermalized neutrons scattered by the moisture in the samples. The CPM, which is proportional to moisture content, is automatically plotted on a variable-speed chart recorder. Speed of the sample and chart recorder is synchronized for a 1:1 reading and printout. This produces a graphic illustration of the variation in moisture content along the tube. Calibration of the equipment is performed by using standard laboratory-prepared soil samples of known density and moisture encased in 3-in.-diam steel sample tubes. A moisture content versus CPM calibration curve is prepared.

56. Experiments conducted under this project on both standard and unknown soil samples show that neutron radiography does have considerable applicability to soil studies, especially in defining distribution of moisture within a sample. Quantification of moisture from film densities is also feasible in 3/8-in.-thick samples. However, quantification through film density measurements of samples 3 in. or

greater in thickness will require further research and development.

57. Laboratory testing shows that moisture gaging of unopened 3-in. steel-encased soil samples through scanning with a fast neutron beam is achievable. Further refinements are also necessary, however, to produce the desired degree of accuracy for moisture gaging of thin, discrete soil layers.

BIBLIOGRAPHY

Berger, H., Neutron Radiography, Elsevier, New York, 1965.

Courtney, J. C. and McIlhenny, R. C., "Shielding Analysis and Safety Recommendations for Waterways Experiment Station Californium 252 Facility," 1973, Engineering Geology and Rock Mechanics Division, U. S. Army Engineer Waterways Experiment Station, CE, Vicksburg, Miss.

Hootman, H. E., "Estimation of ^{252}Cf Shielding Requirements," Research and Development Report DP-1232, 1970, U. S. Atomic Energy Commission, Savannah River Laboratory, Aiken, S. C.

U. S. Atomic Energy Commission, Savannah River Plant, "Californium 252 Progress," Aiken, S. C.

Report No. 2, Jan 1970
Report No. 7, Apr 1971
Report No. 9, Oct 1971
Report No. 12, Jul 1972
Report No. 15, May 1973

U. S. Atomic Energy Commission, Savannah River Operations Office, "Guide for Fabricating and Handling Californium 252 Sources," Report SRO-153, Jan 1971, Aiken, S. C.

U. S. Atomic Energy Commission, Savannah River Operations Office, "Californium 252, Its Use and Market Potential," Sep 1969, Aiken S. C.

Table 1
Neutrons from Spontaneous
Fission of ^{252}Cf *

<u>Energy</u> <u>Mev</u>	<u>Total Neutron</u> <u>Emission per second</u> <u>from a 10-mg Source</u>
0-0.5	2.8×10^9
0.5-1.0	3.7×10^9
1.0-2.0	7.6×10^9
2.0-3.0	4.6×10^9
3.0-4.0	2.8×10^9
4.0-5.0	1.6×10^9
5.0-6.0	5.6×10^8
6.0-7.0	4.0×10^8
7.0-8.0	1.3×10^8
8.0-10.0	9.9×10^7
10.0-13.0	2.2×10^7
Total	<u>2.4×10^{10}</u>

* D. H. Stoddard and H. E. Hootman, "252 Cf Shielding Guide," Research and Development Report DP-1246, 1971, U. S. Atomic Energy Commission, Savannah River Laboratory, Aiken, S. C.

Table 2
Gamma Rays from Spontaneous Fission of 10 mg of ^{252}Cf

Energy Mev	Prompt Gammas	Equilibrium Fission Product Gammas	Total Gamma Production
0-0.5	3.3×10^{10}	1.3×10^{10}	4.6×10^{10}
0.5-1.0	1.7×10^{10}	4.0×10^{10}	5.7×10^{10}
1.0-1.5	7.7×10^9	9.1×10^9	1.7×10^{10}
1.5-2.0	4.2×10^9	3.5×10^9	7.7×10^9
2.0-2.5	2.2×10^9		2.2×10^9
2.5-3.0	1.1×10^9		1.1×10^9
3.0-3.5	5.6×10^8		5.6×10^8
3.5-4.0	3.0×10^8		3.0×10^8
4.0-4.5	1.7×10^8		1.7×10^8
4.5-5.0	8.2×10^7		8.2×10^7
5.0-5.5	4.9×10^7		4.9×10^7
5.5-6.0	1.8×10^7		1.8×10^7
6.0-6.5	1.0×10^7		1.0×10^7
		Total	1.3×10^{11}

Table 3
Engineering Properties of Soil Standards
for Radiographic Experiments

<u>Soil Standard No.</u>	<u>Soil Type</u>	<u>Moisture Content percent</u>	<u>Wet Density lb/cu ft</u>	<u>Dry Density lb/cu ft</u>
4-A	CH	9.5	96.2	88.5
4-B	CH	15.5	114.2	98.9
4-C	CH	29.5	118.2	91.4
5-A	CL	5.9	100.2	94.6
5-B	CL	12.8	126.2	111.9
5-C	CL	17.8	129.6	110.0
6-A	ML	3.2	92.2	89.3
6-B	ML	9.3	99.2	90.8
6-C	ML	11.8	117.4	105.0

APPENDIX A: DETAILED PLANS OF
THE CALIFORNIUM-252 FACILITY
AND COMPONENTS

A-i

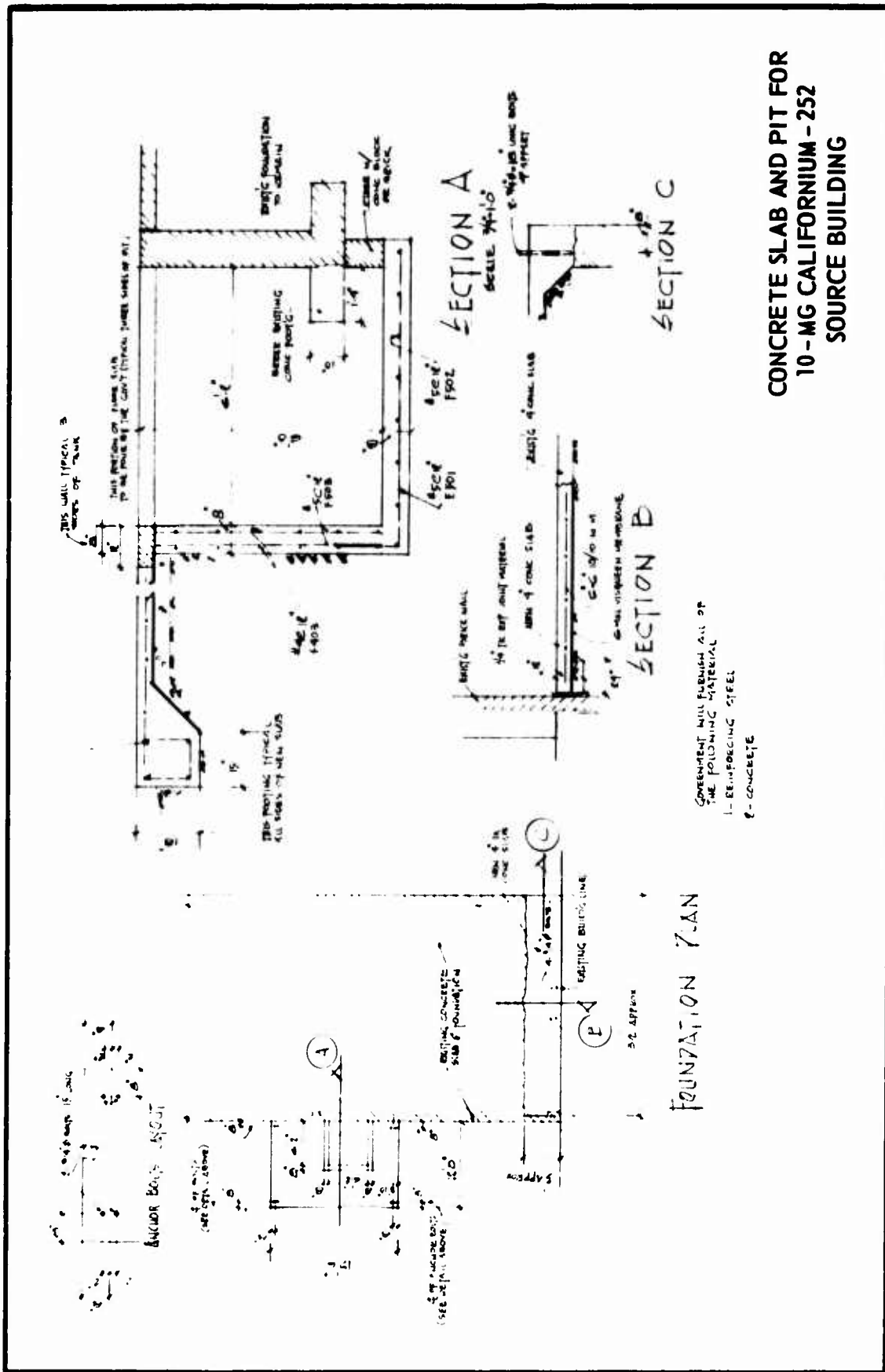

CONCRETE SLAB AND PIT FOR
10-MG CALIFORNIA - 252
SOURCE BUILDING

GOVERNMENT WILL FURNISH ALL OF
THE FOLLOWING MATERIAL
1 - REINFORCING STEEL
P - CONCRETE

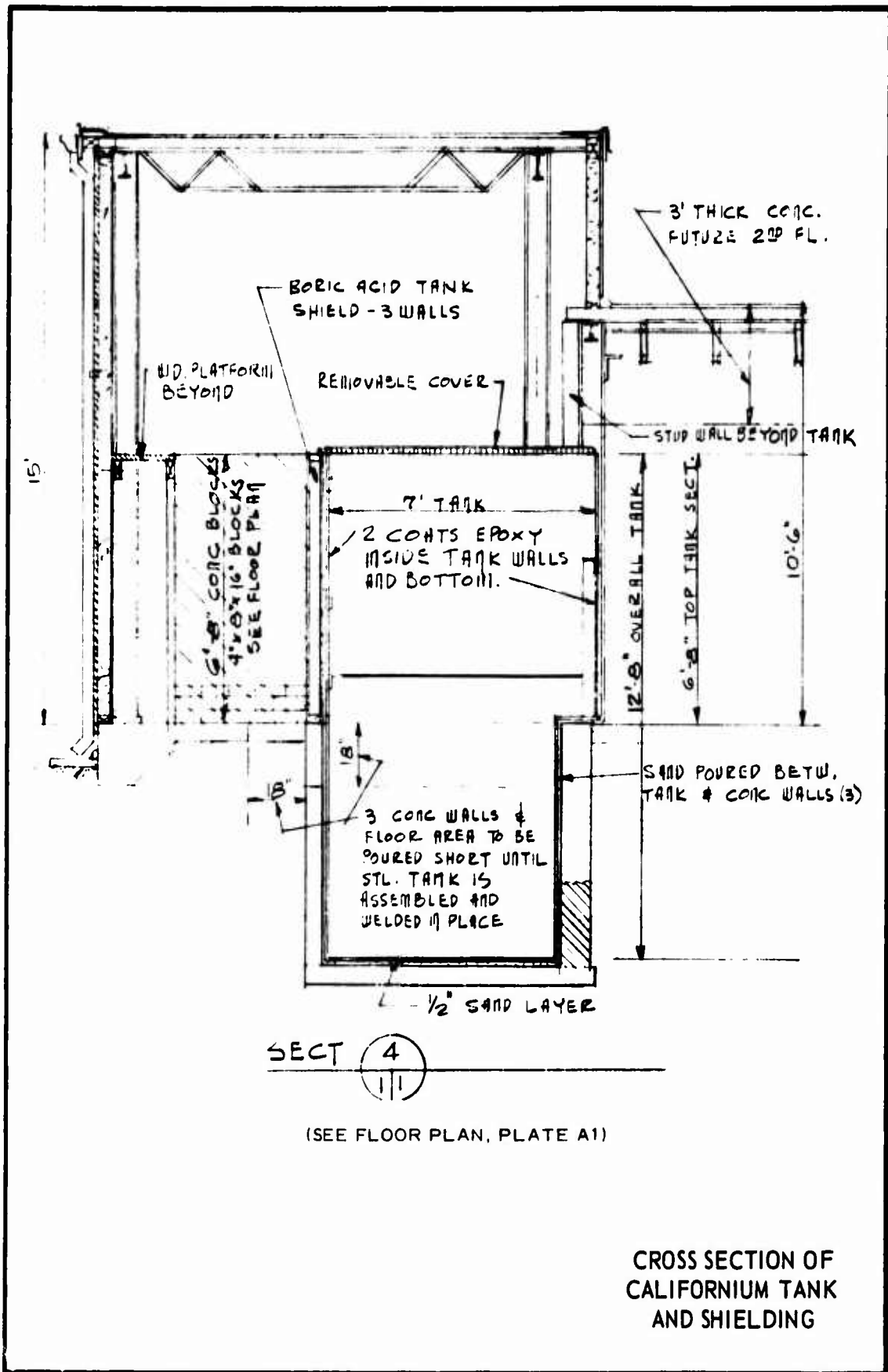

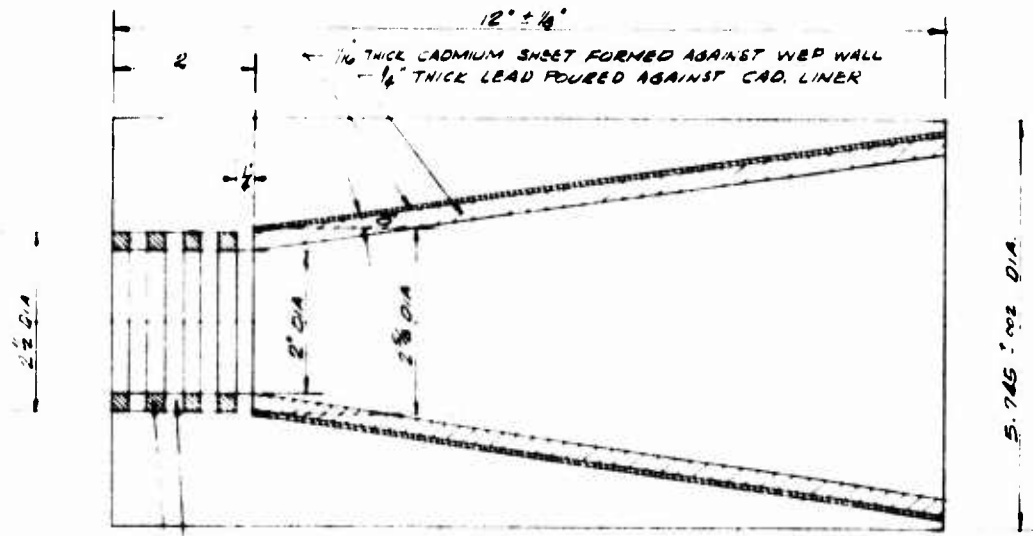

ALTERNATE
1/8" THICK
LEAD RINGS
W.E.P. RINGS

U.S. ARMY ENGINEER WATERWAYS

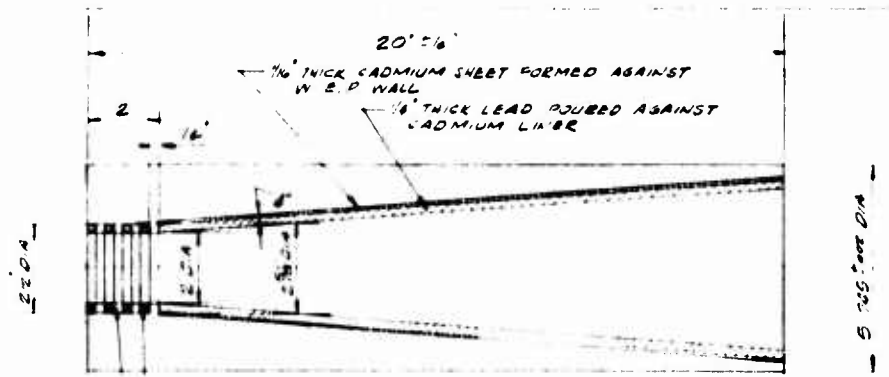

ALTERNATE 1/8" THK
LEAD RINGS
W.E.P. RINGS

WATER EXTENDED POLYESTER
SHE REQ'D

CALIFORNIUM-252
COLLIMATORS

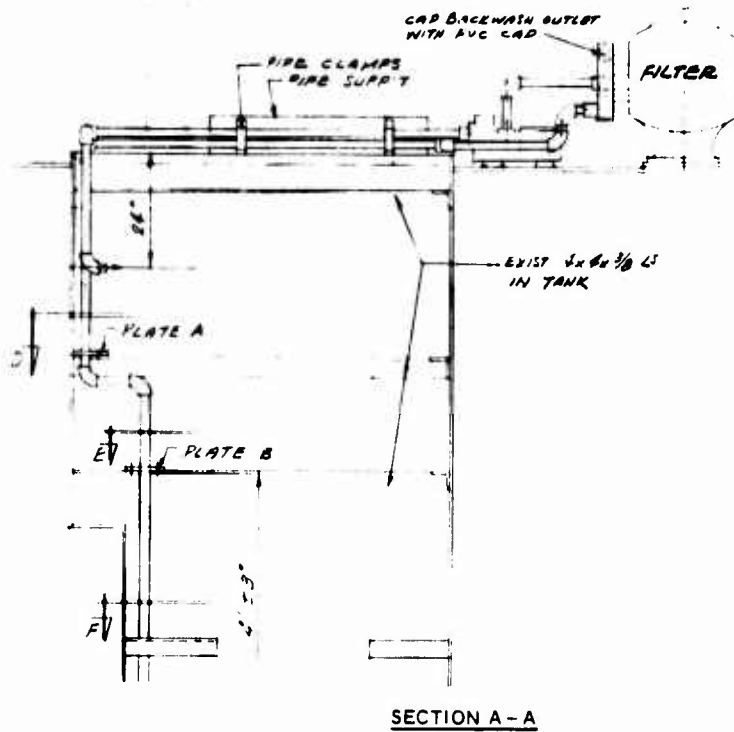
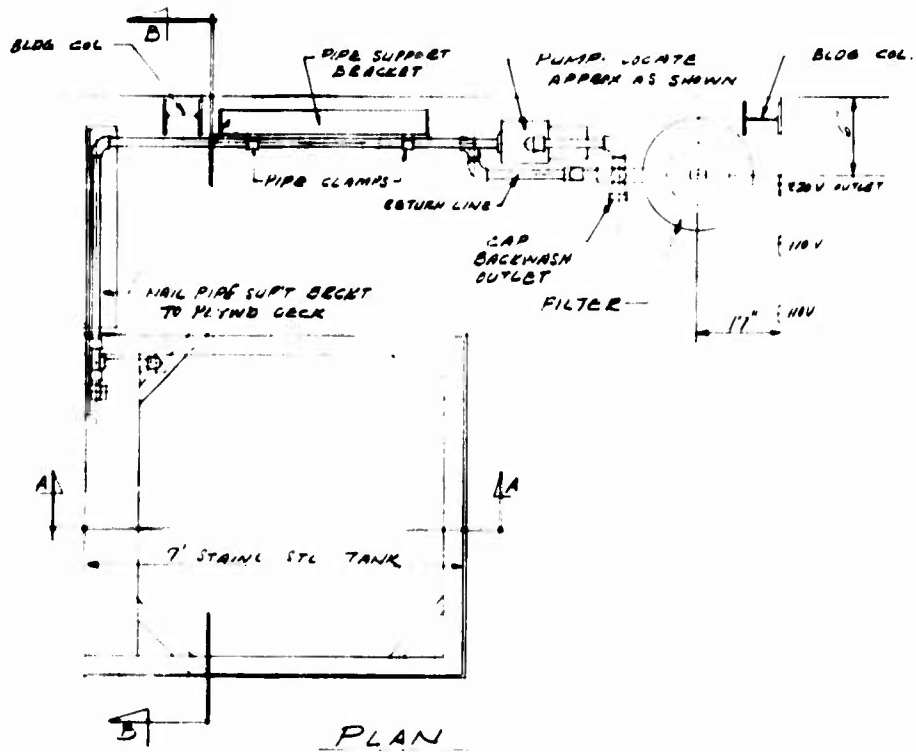

WATER FILTER SYSTEM

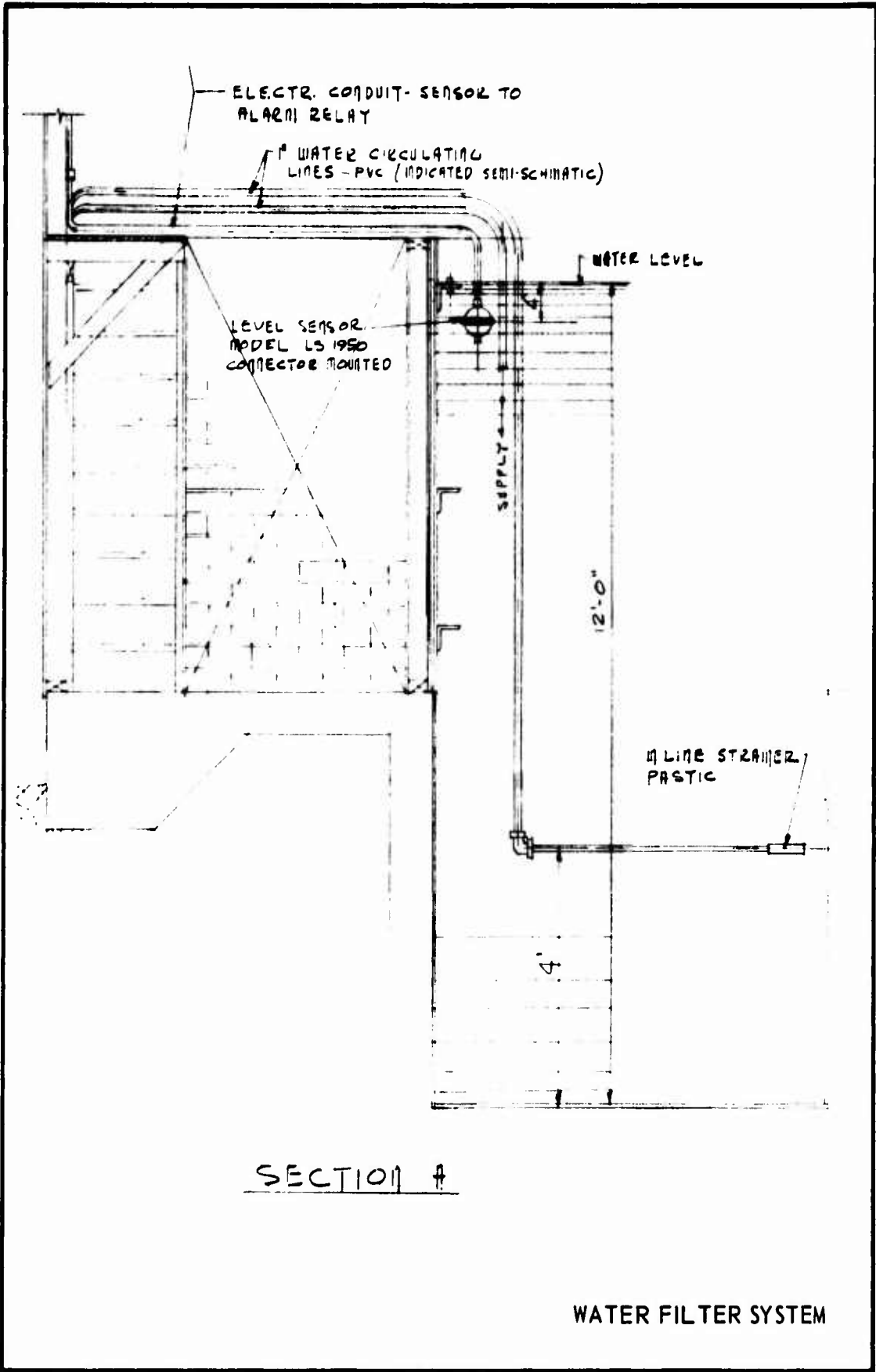

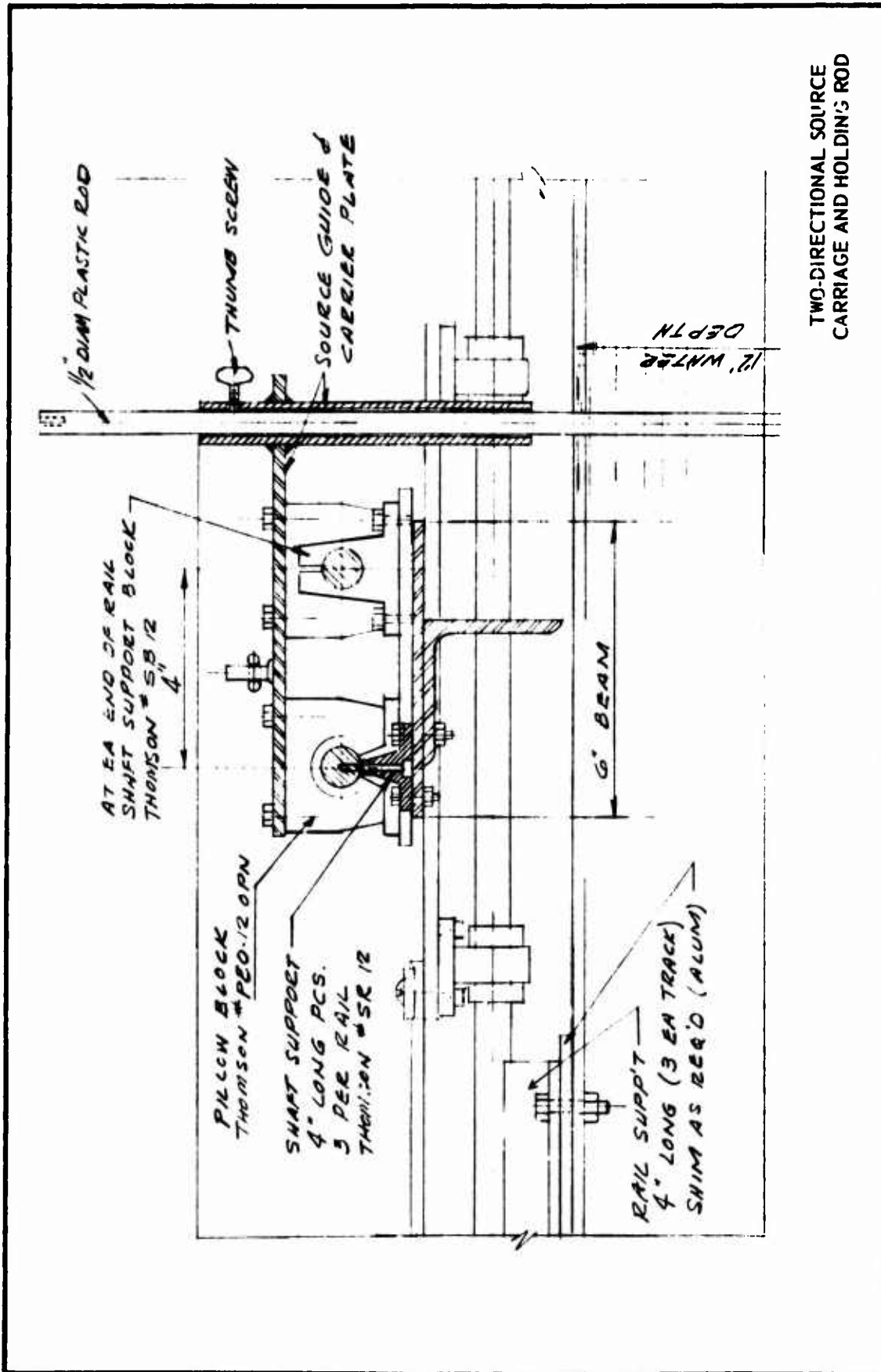

TWO-DIRECTIONAL SOURCE
CARRIAGE AND HOLDING ROD

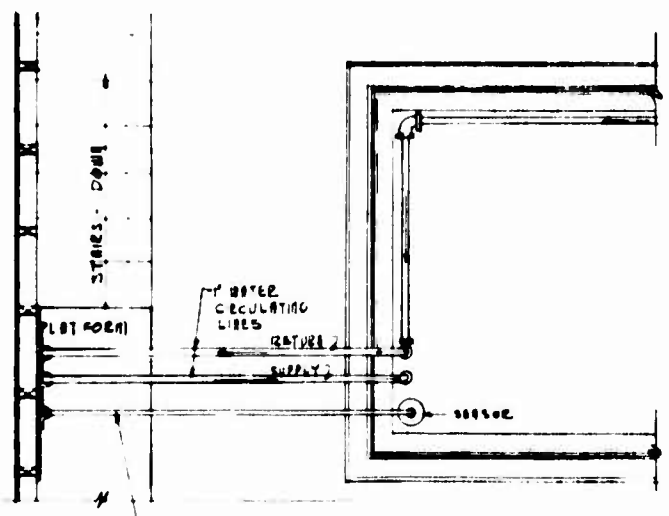

TOP VIEW

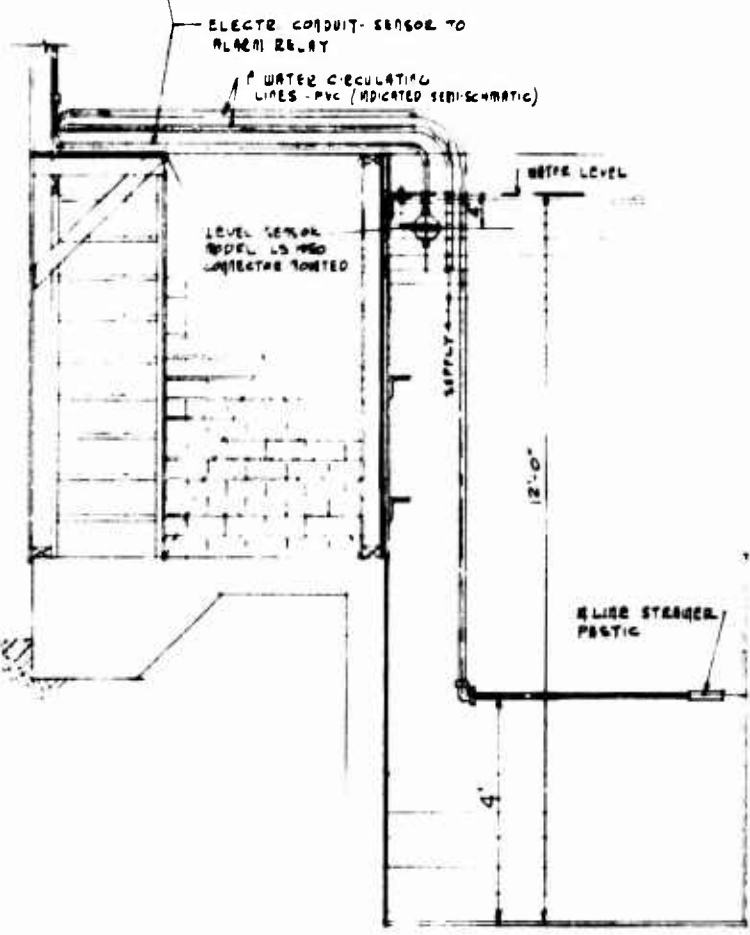

SECTION 1

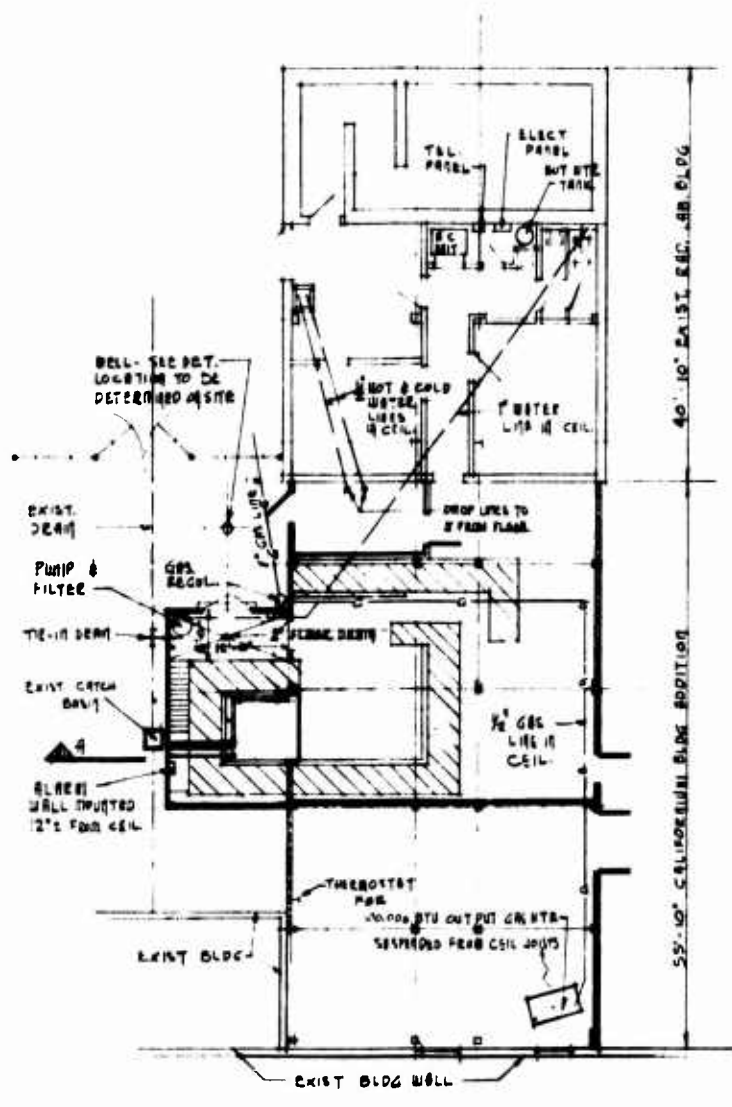

FLOOR PLAN - MECHANICAL



40' 10" EAST. REC. BR. BLDG.
55' 10" CALIFORNIA BLDG. ADDITION

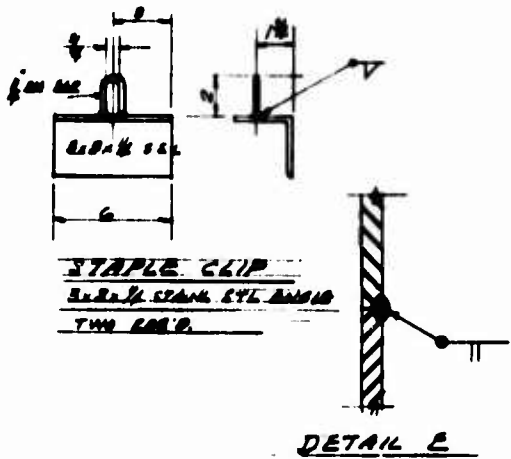

DETAIL E

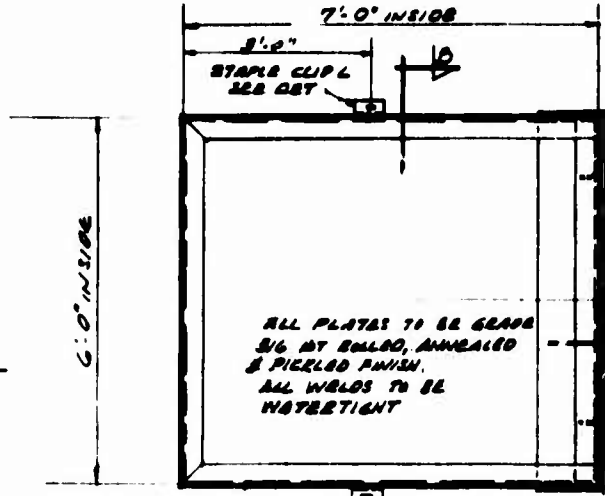

TOP VIEW

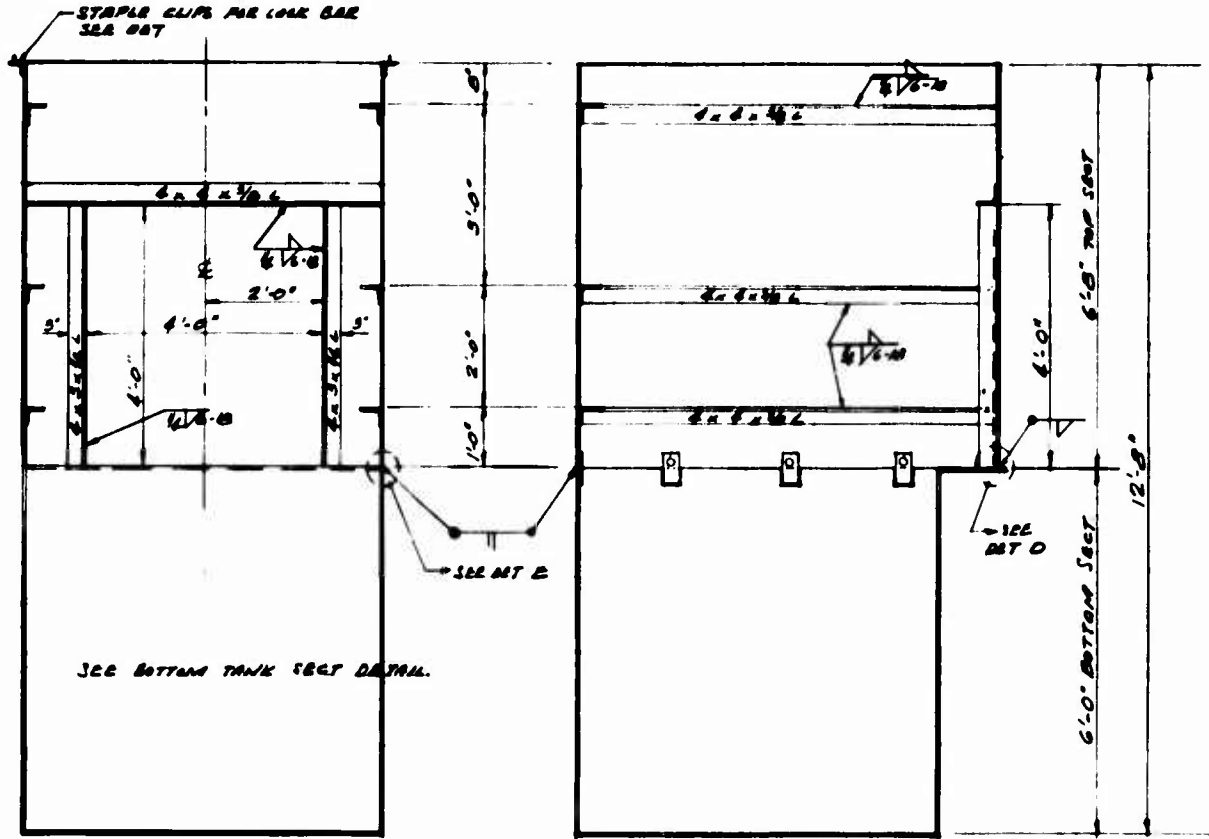

SECTION B

SECTION A

TANK ASSEMBLY

TOTAL WT. 2,000 LBS

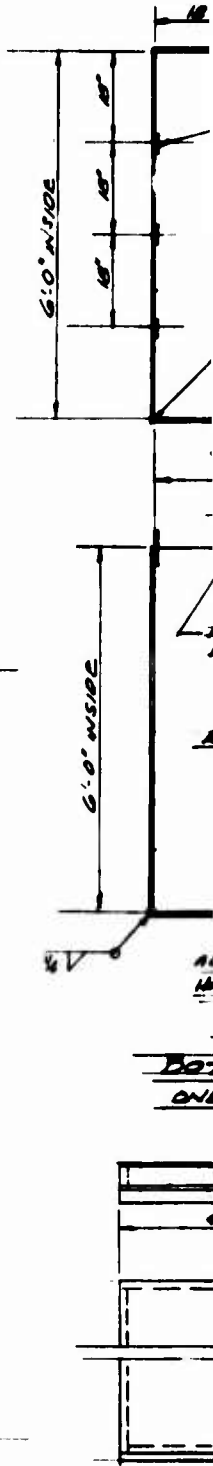

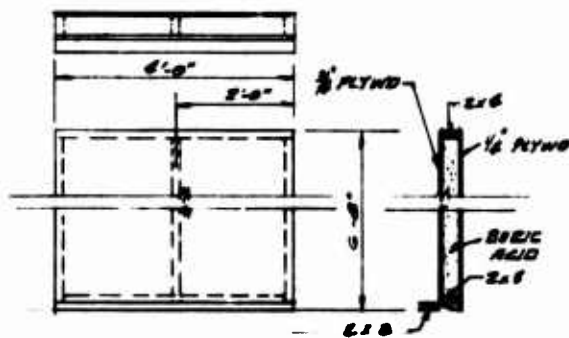
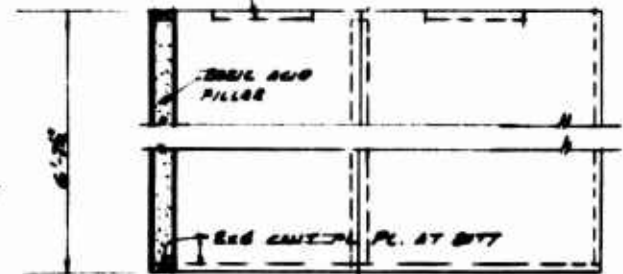
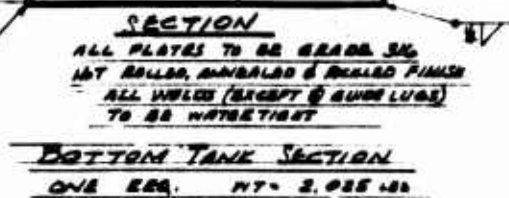
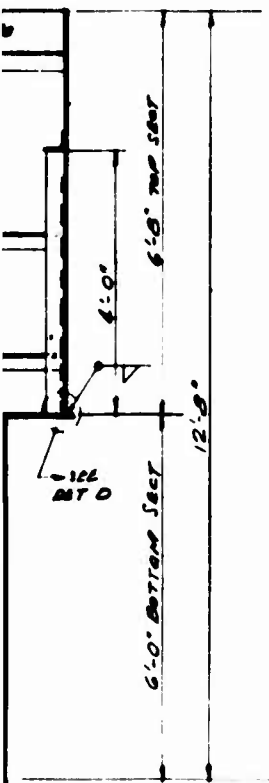
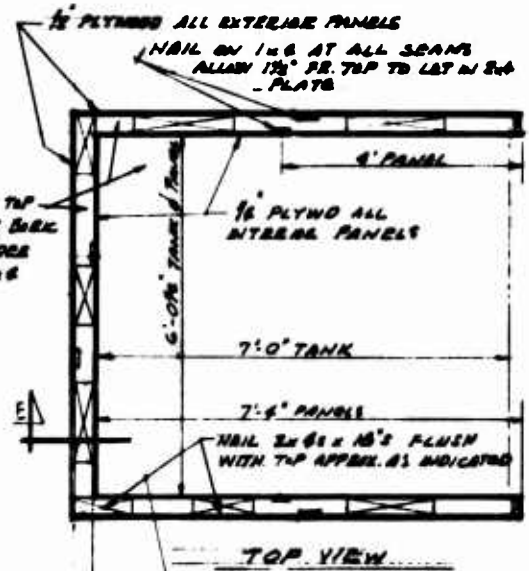
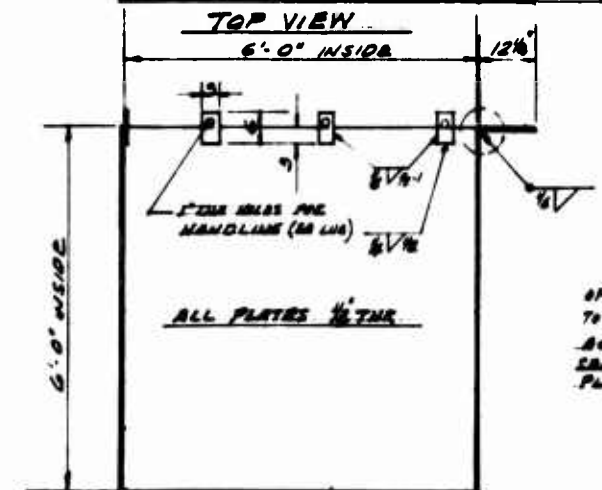
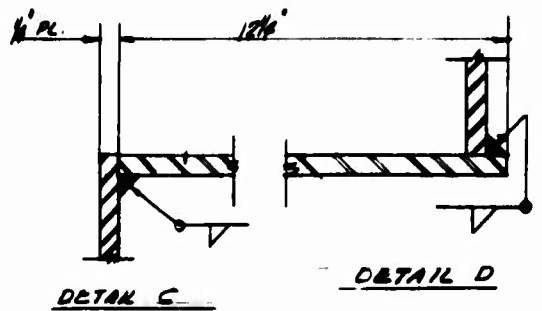
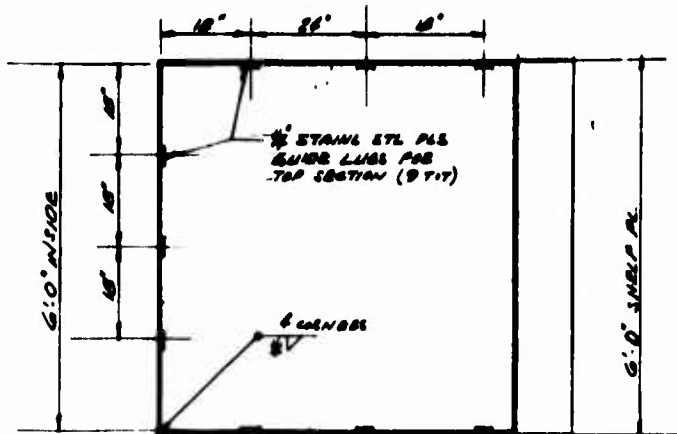
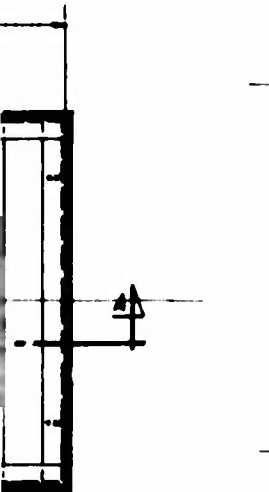

WALL SHIELD
 9 REQ'D EST WT. 400 LBS

TANK SHIELD
 ONE REQ.

TANK DETAILS
 10-MG CALIFORNIUM-252
 SOURCE BUILDING
 EXT TO BLDG 1006

7 - 6,000 LBS

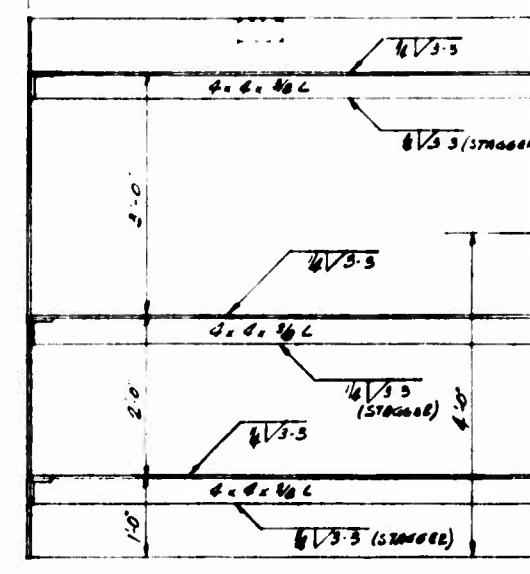
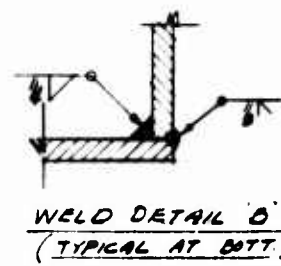
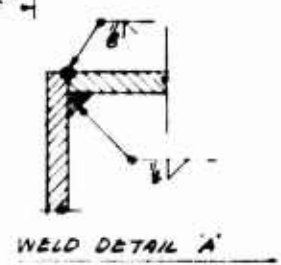
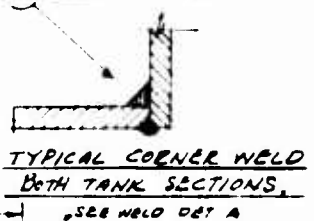
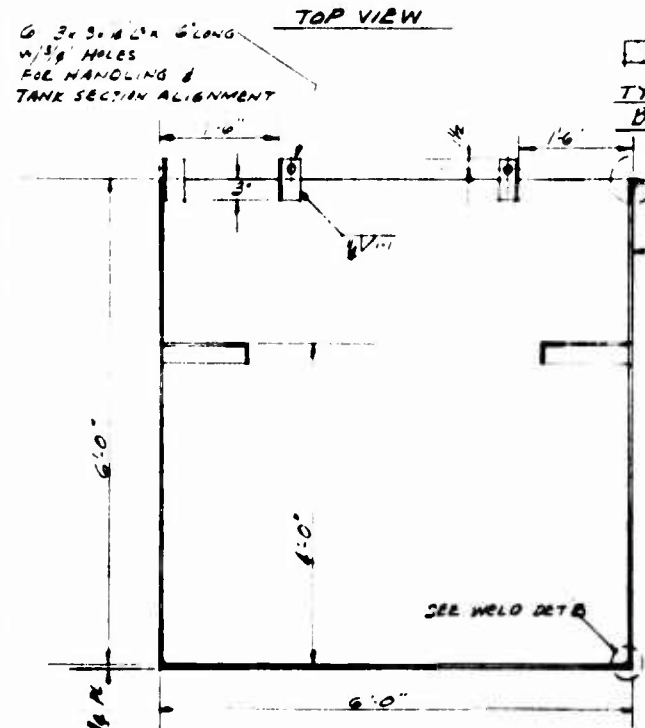
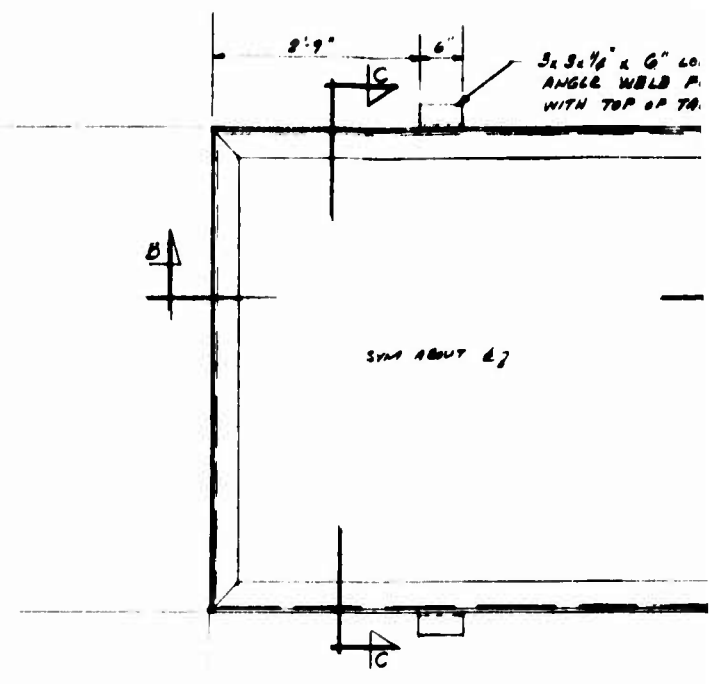
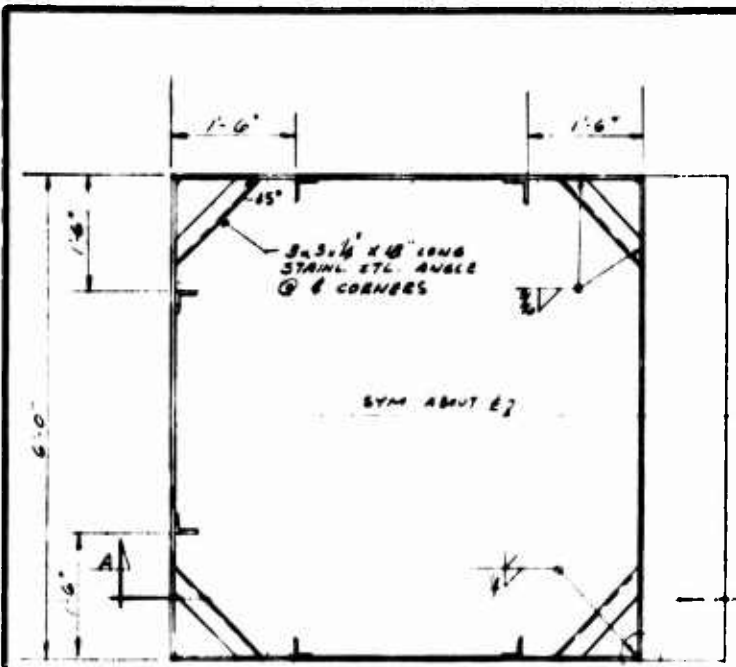

SECTION A-A

BOTTOM SECTION

SECTION B-B

TOP SECTION

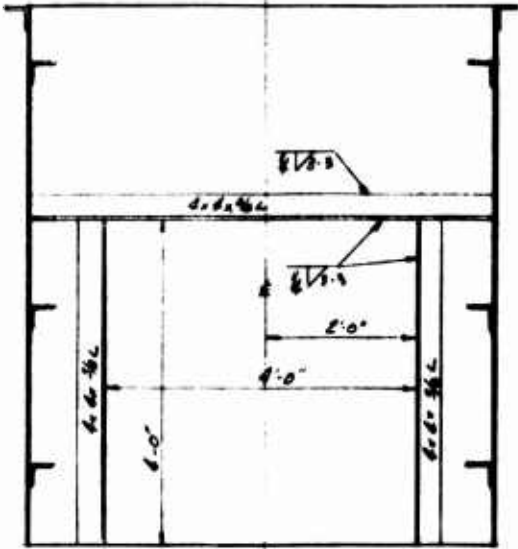
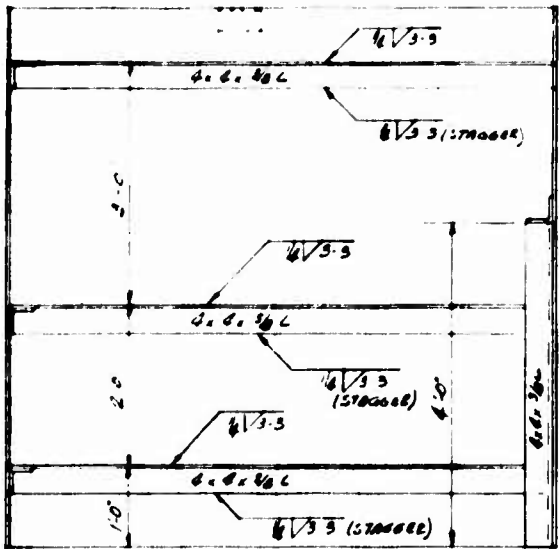
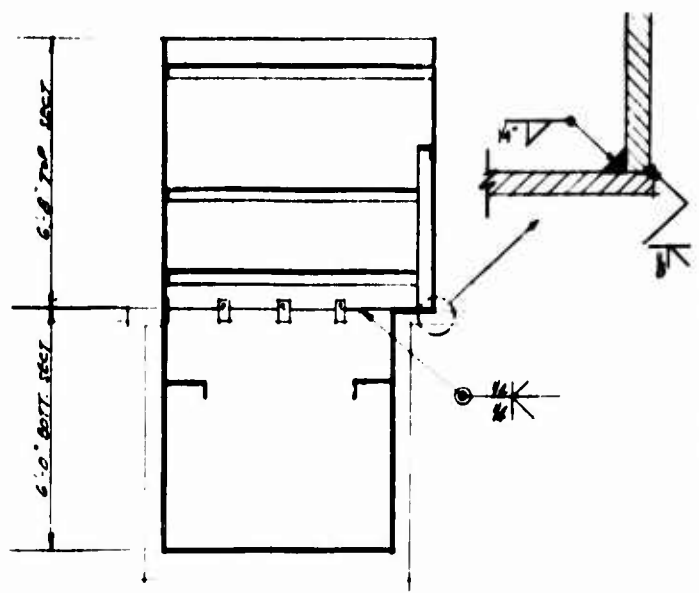
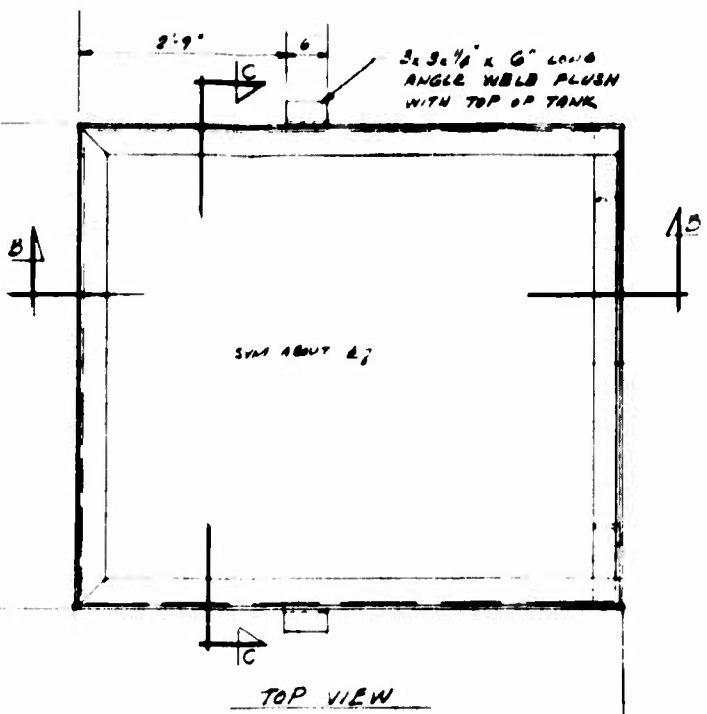

NOTE:
TANKS TO BE WELDED WATER-TIGHT.
ALL MATERIAL TO BE STAINLESS STEEL FURNISHED BY GOVT.

TOP SECTION

STAINLESS STEEL TANK FOR CALIFORINIUM - 252

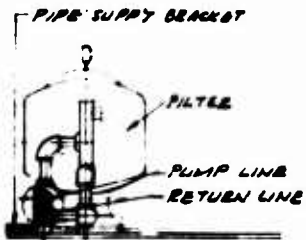
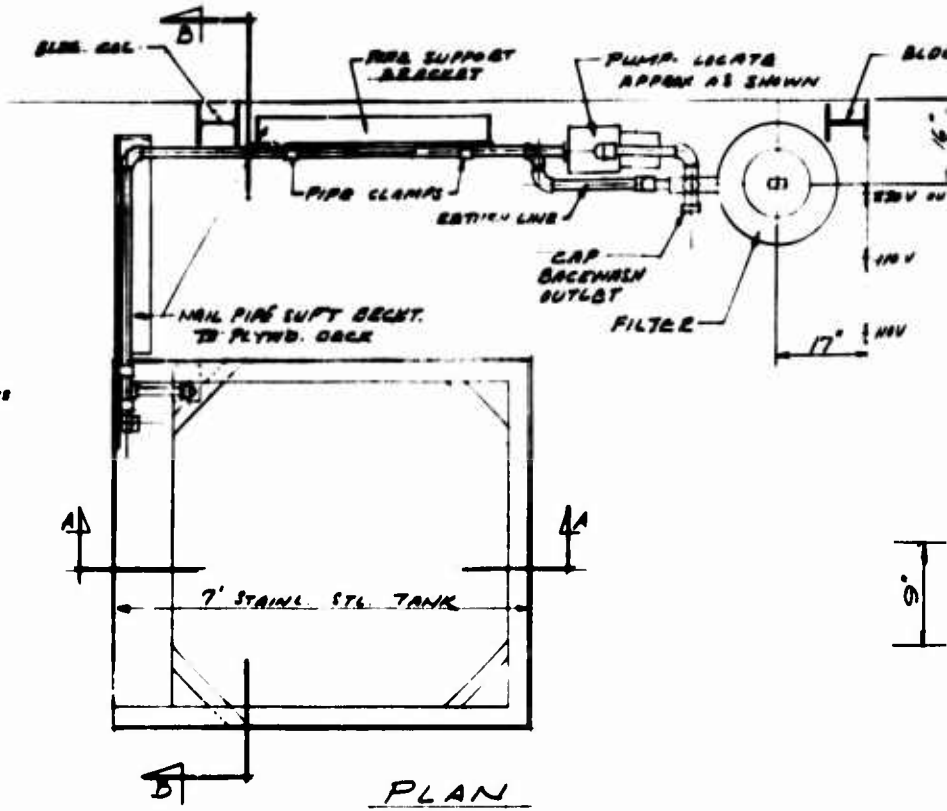
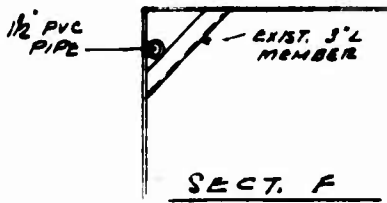
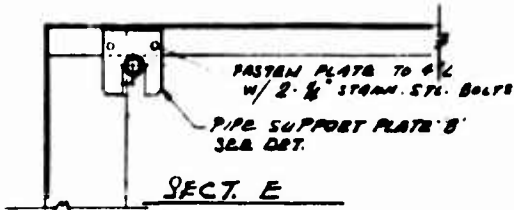
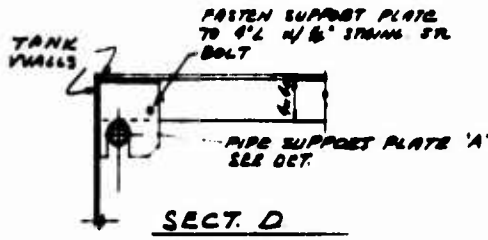

SECT. C
PIPE SUPPLY BRACKET

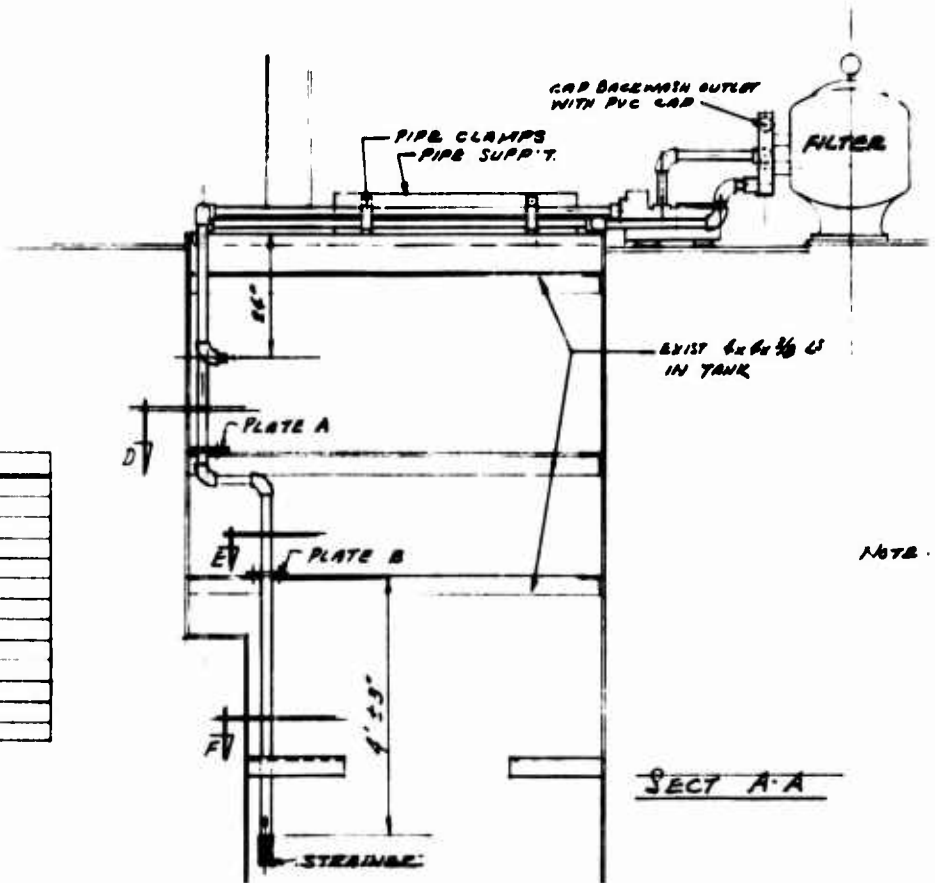

SECT. A-A

NOTE: ALL DIMENSIONS ARE IN INCHES

LIST OF MATERIAL

NO	DESCRIPTION
35 FT	PVC PIPE - 1 1/2" SCH. 40
11 PA	" ELBS - 90° - 1 1/2"
5	" 1 1/2" MALE ADAPTERS
1	" 1 1/2" CAP
1	STRAINER, 1 1/2" REMASTER 20000
1 EA	HIGH CAPACITY FILTER - FIBERGLASS
1 EA	PUMP - 1 HP
1 PC	PLYWD. - 3/8" x 10' x 8' 0"
1	2x6 FIBR. - 8' 0"
6 EA	PIPE CLAMPS - 1 1/2"
1 PC	PLATE - 1/2" x 9' x 1' 0"

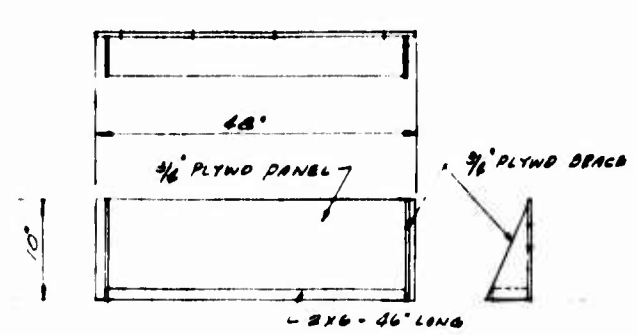
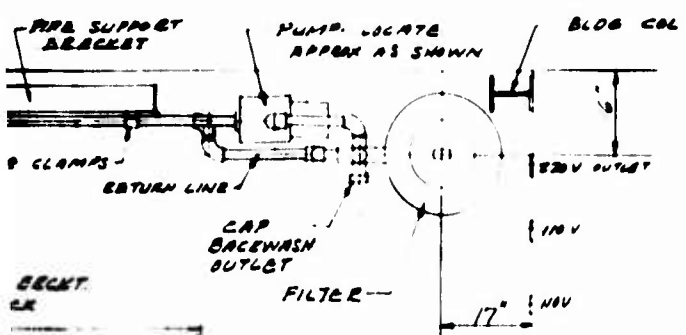

PIPE SUPPORT BRACKET
 WOOD - ONE REQ'D (NOT TO SCALE)



PLAN

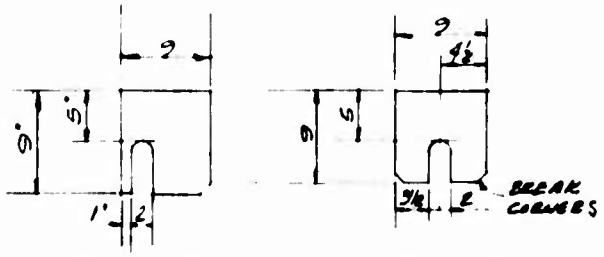
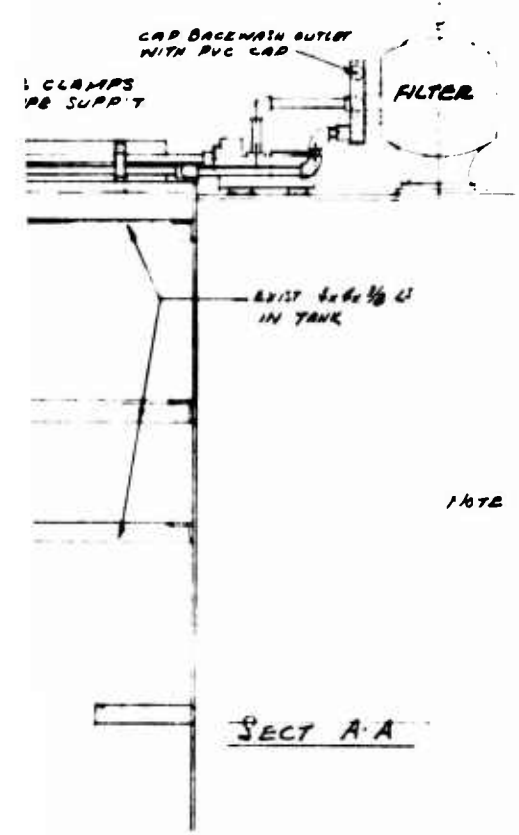

PLATE A PLATE B

PIPE SUPPORT PLATES
 1/2" THK PLEXIGLAS
 ONE EACH REQ'D



SECT A-A

NOTE ALL PIPE & FITS ARE PVC SCHED 40

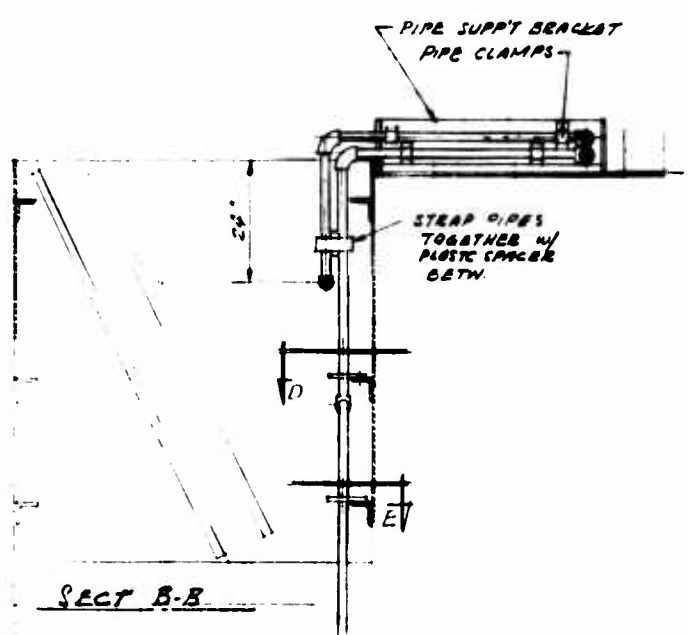

SECT B-B

**WATER CIRCULATING SYSTEM
 FOR CALIFORNIUM TANK
 BLDG 1006**

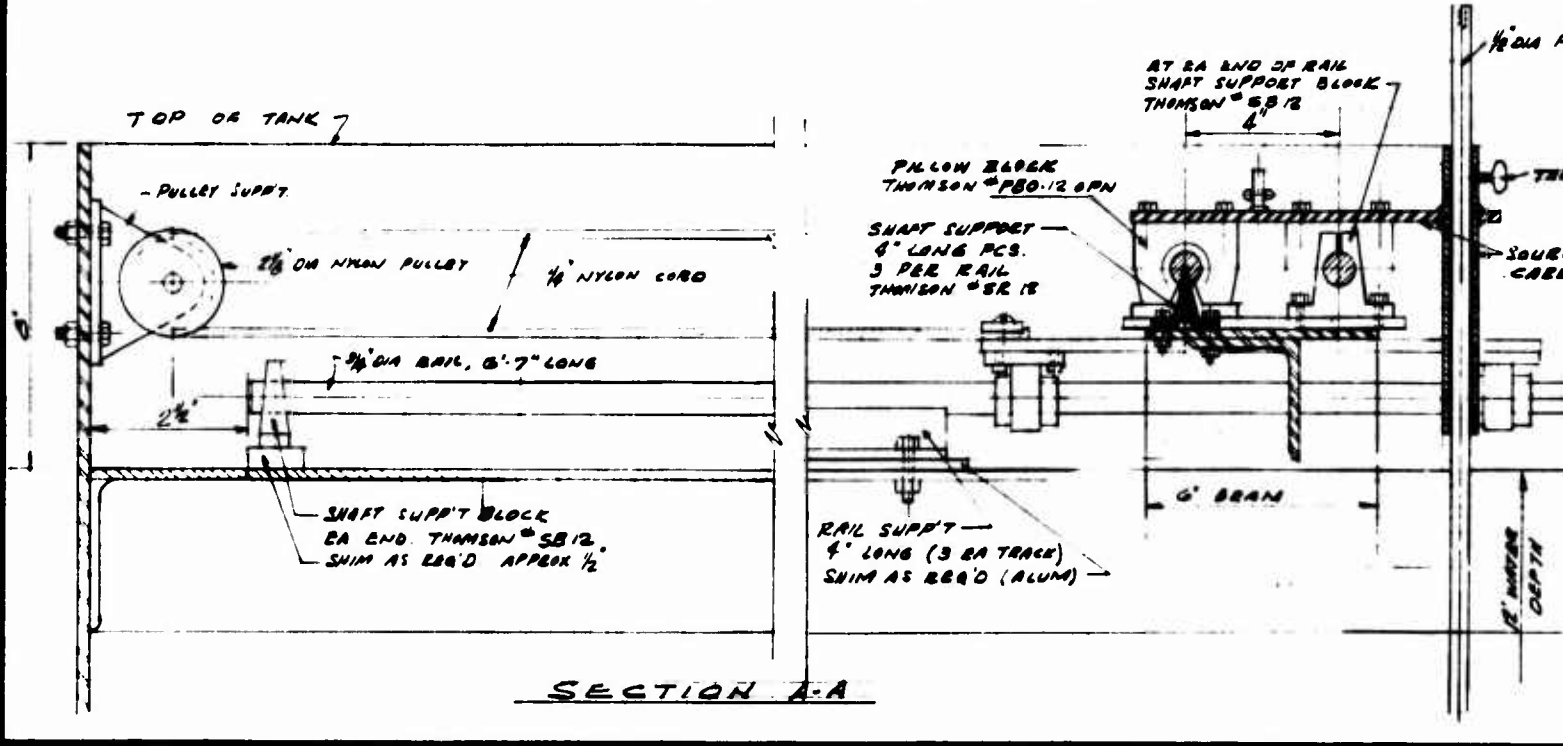
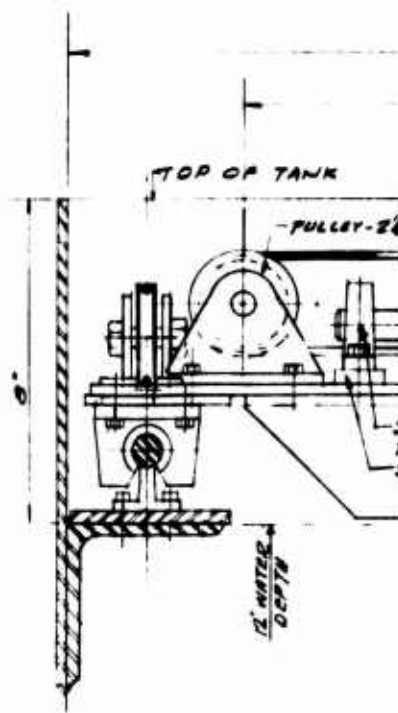
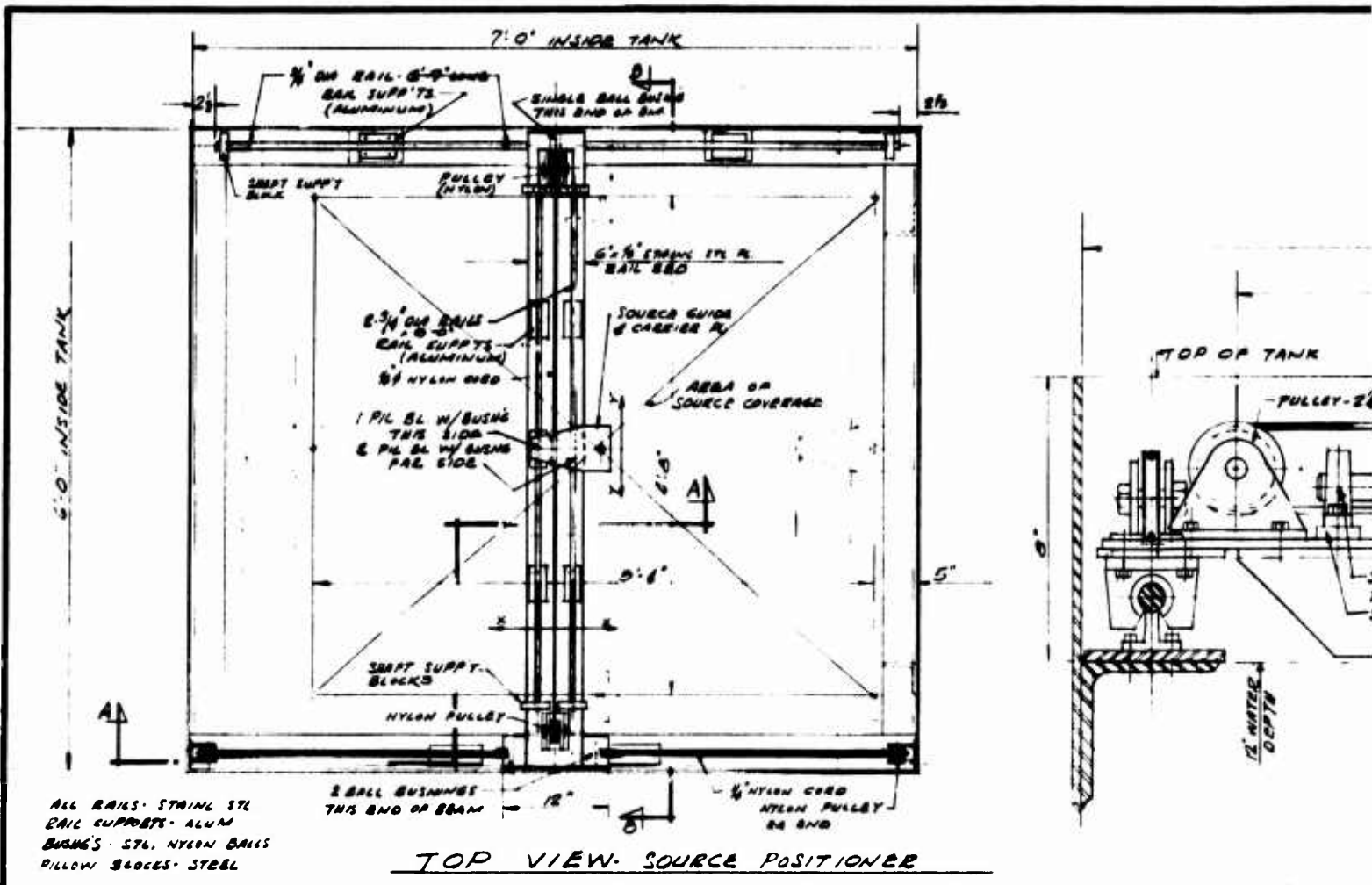

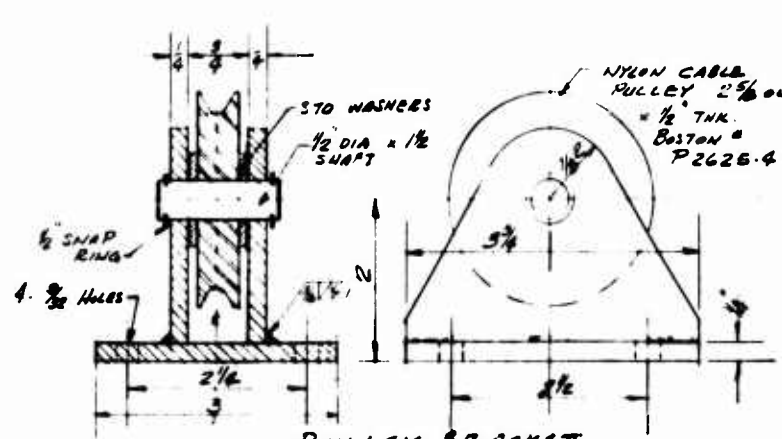
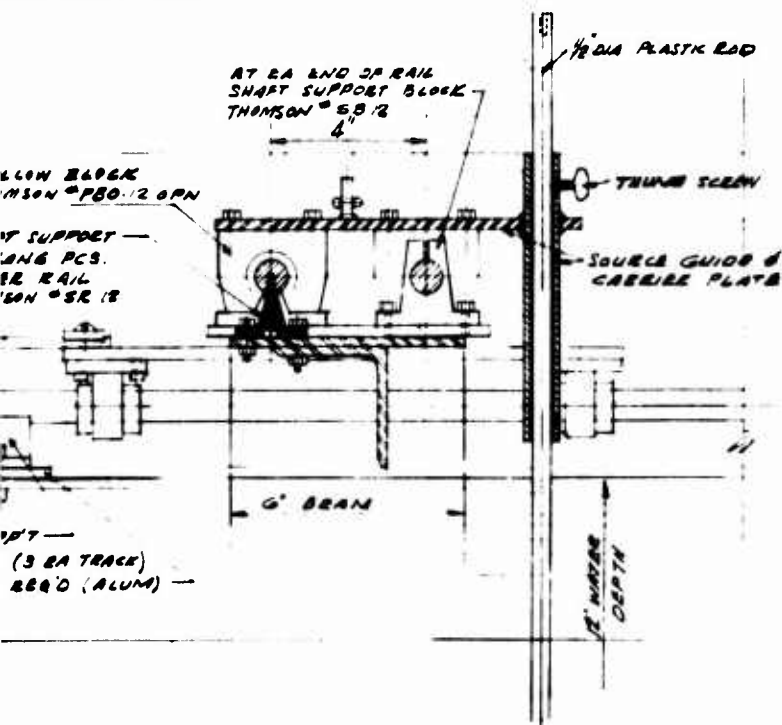
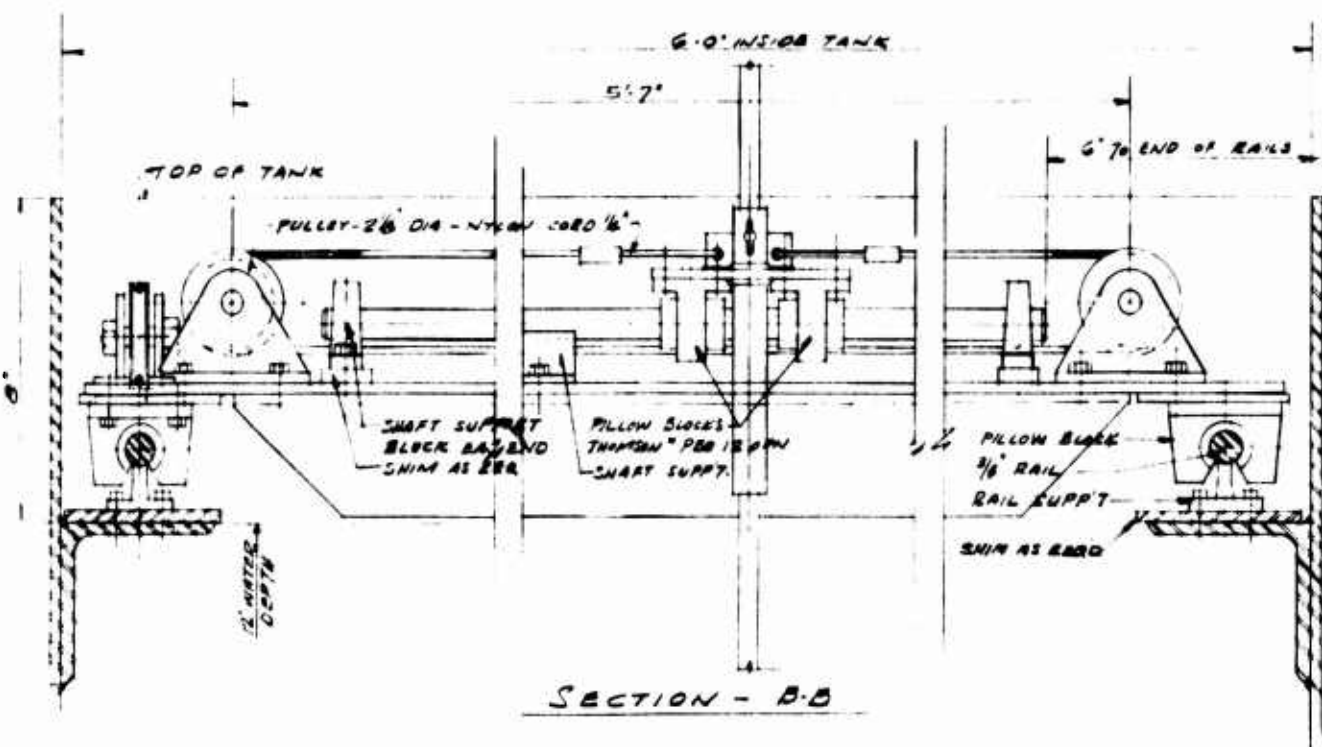
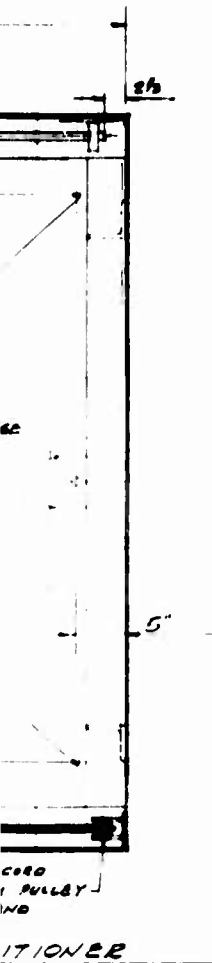

PULLEY BRACKETS
STL - 4 REQ'D

SOURCE POSITIONER
10-MG CALIFORNIUM-252
SOURCE BUILDING
EXT TO BLDG 1008

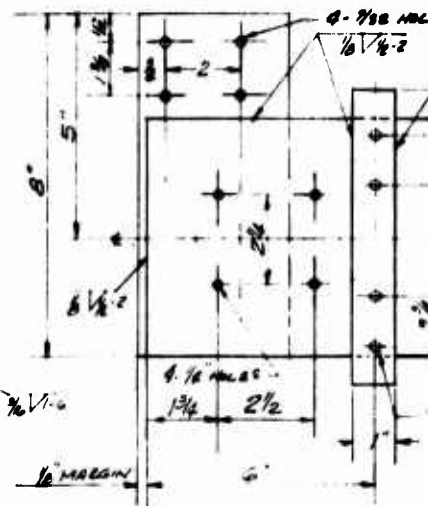
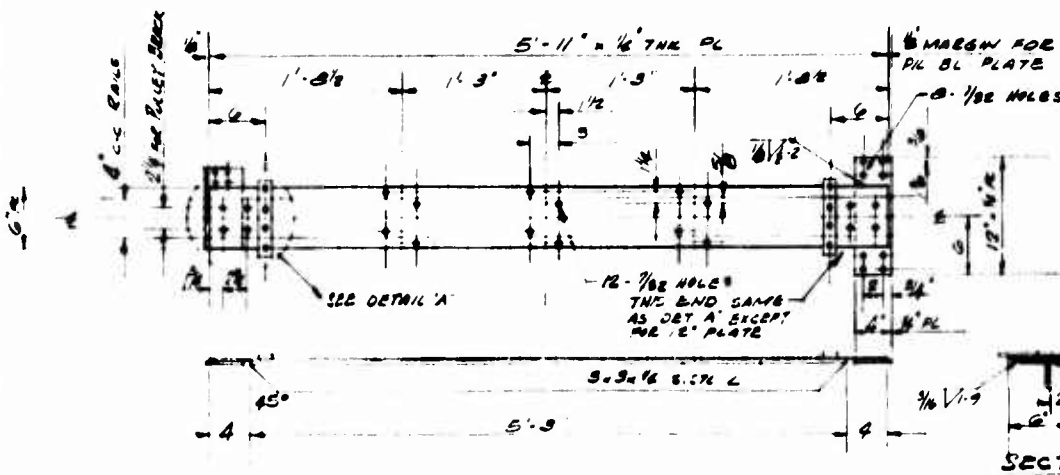

SOURCE CARRIER BEAM
 316 STAINLESS STL PLS
 308 STAINL STL ANGLE
 ONE REQ.

DETAIL

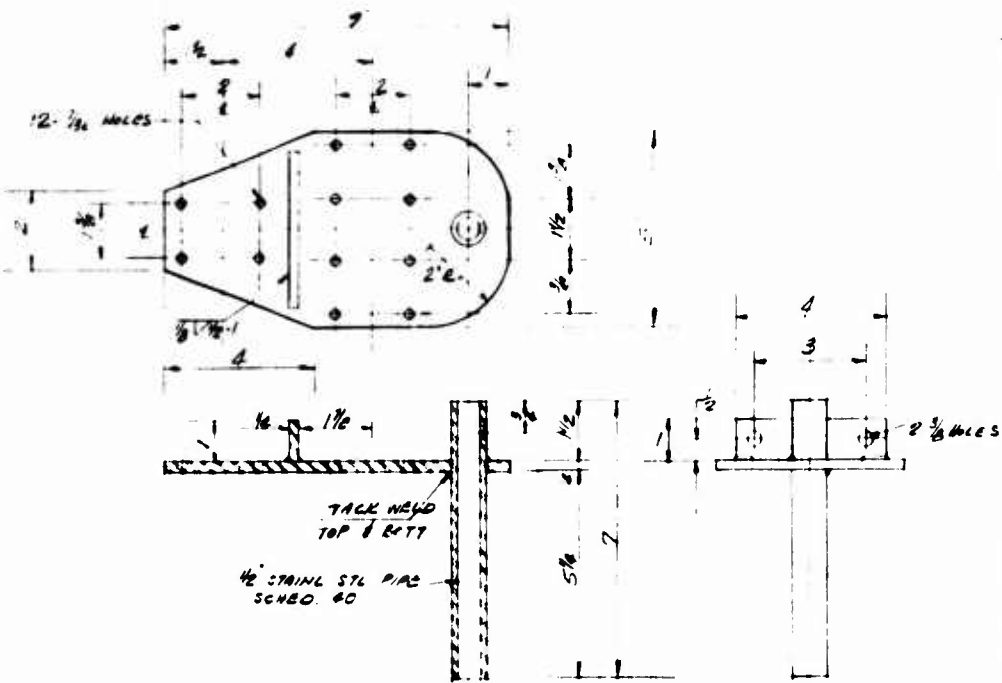

SOURCE GUIDE & CARRIER PLATE
 316 STAINL STL PL ONE REQ.

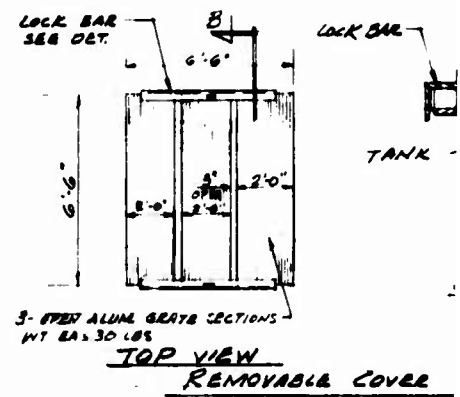

TOP VIEW
REMOVABLE COVER

SOURCE POSITIONER DETAILS

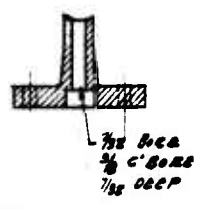
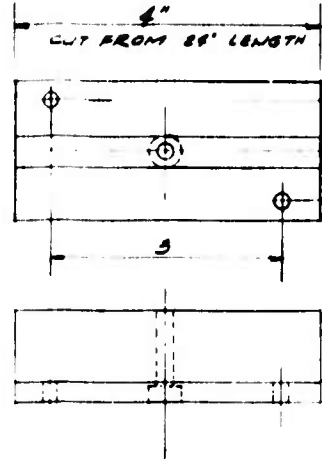
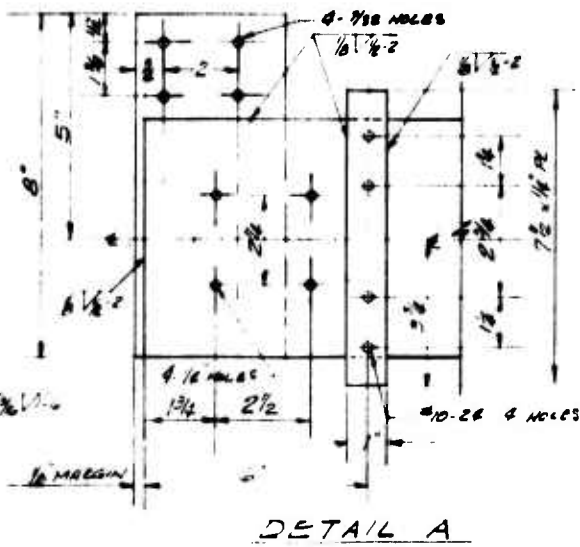

BAIL SUPPORT
THOMSON # SR 12 - ALUM.
12 REQ'D

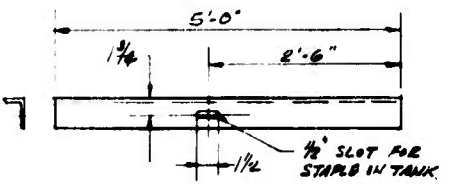
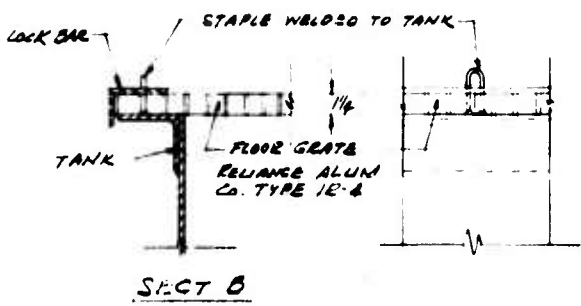
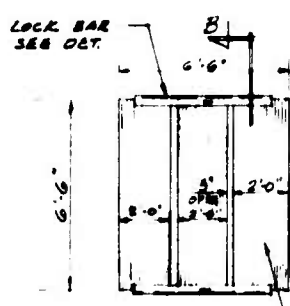

LOCK BAR
3x2x1/4 AL. ANGLE - 2 REQ'D
WT = 9 LBS. EA

REMOVABLE COVER FOR TANK

LATE

SOURCE POSITIONER
10-MG CALIFORNIUM-252
SOURCE BUILDING
EXT TO BLDG 1006

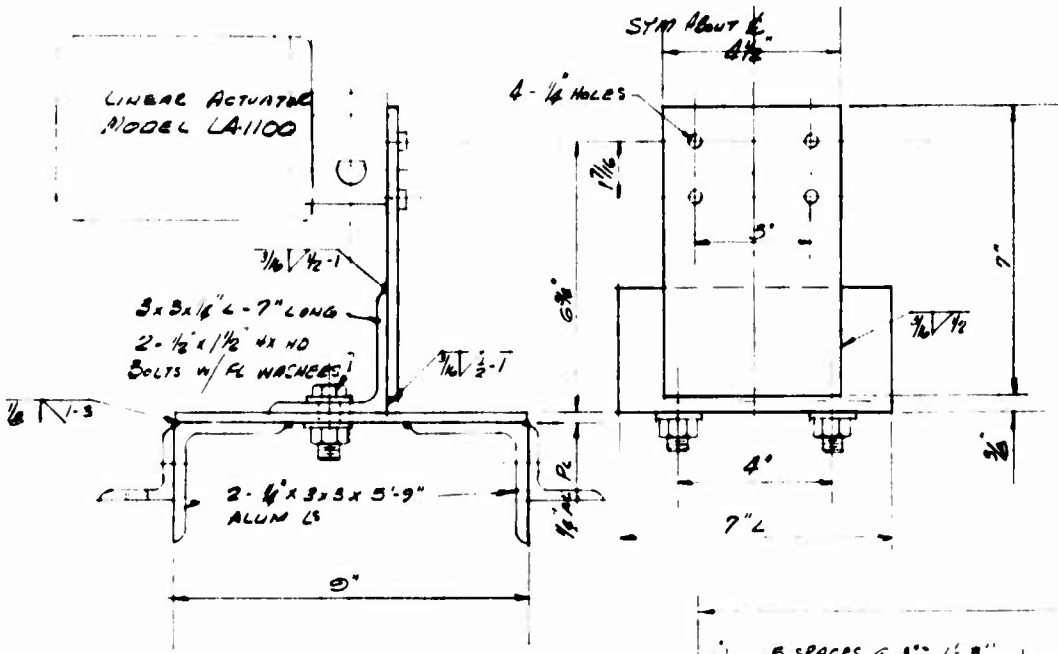

END VIEW A-A
LINEAR ACTUATOR MOUNTING DETAIL

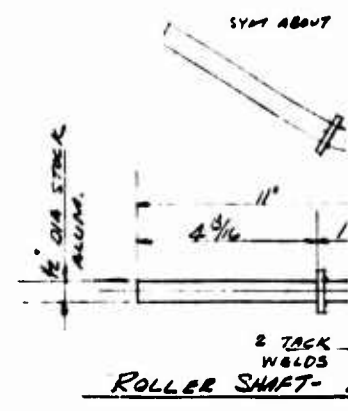

2 TACK WELDS
ROLLER SHAFT

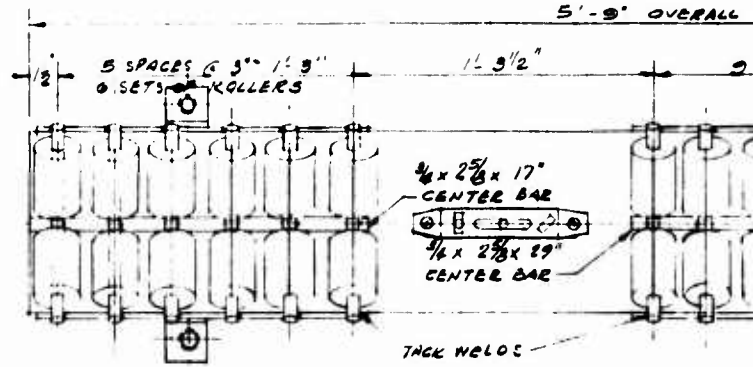

TOP VIEW

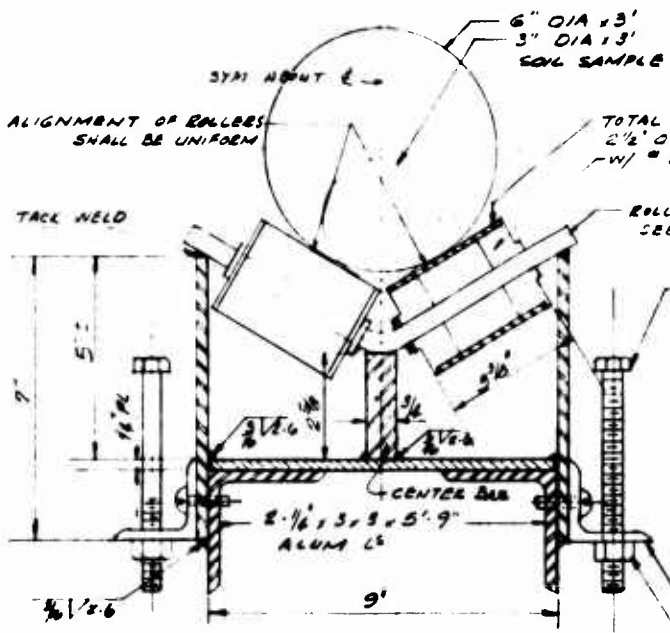

SECT B-B
TYPICAL SECT.

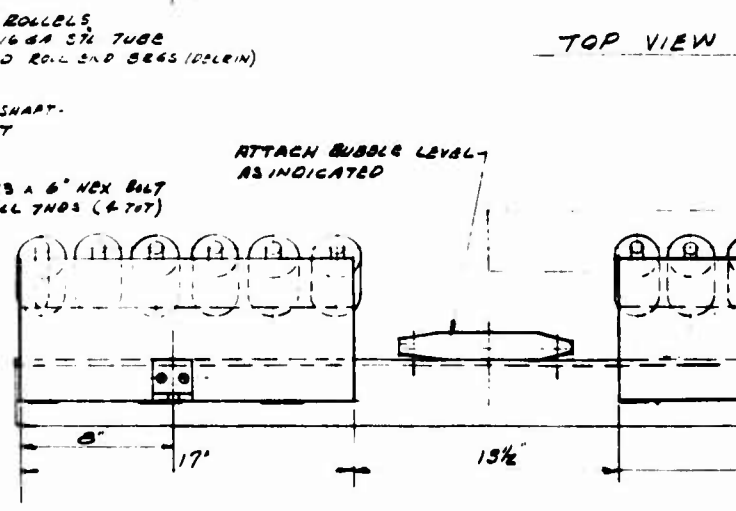

SIDE VIEW

4- 2 x 2 x 1/8 STL L
2" LONG PASTER TO
SIDES W/ 1/2 - 1/8 SCRS

A ADD LEVELLED & SQUARE END 8" x 8"

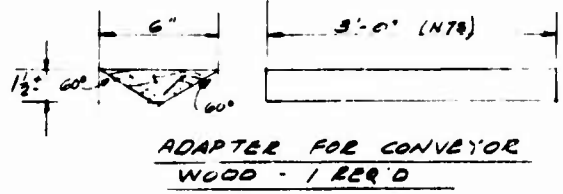
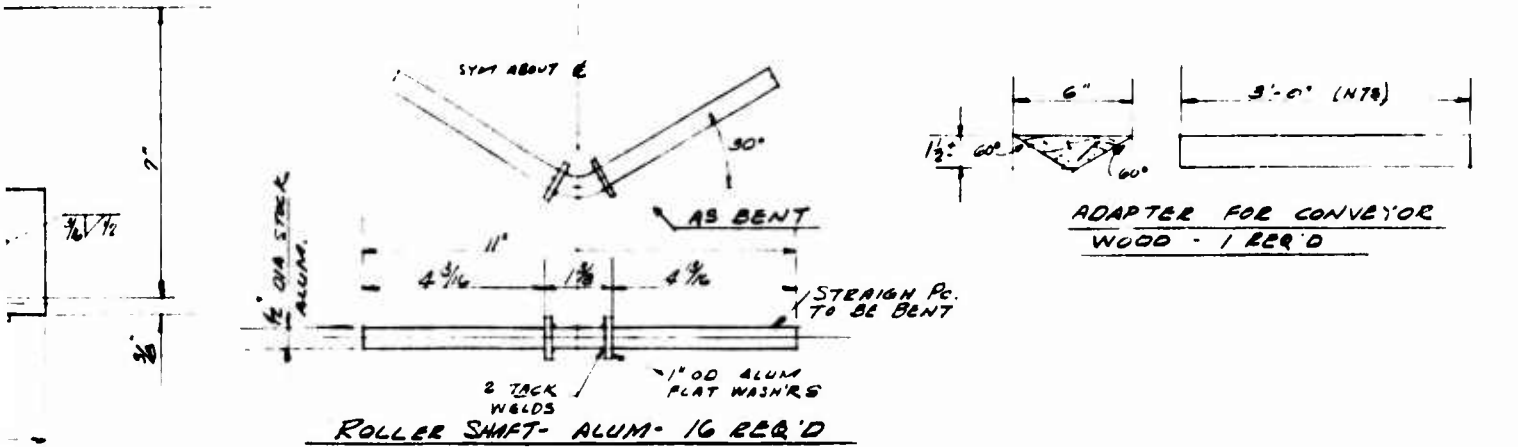

5'-9\"/>

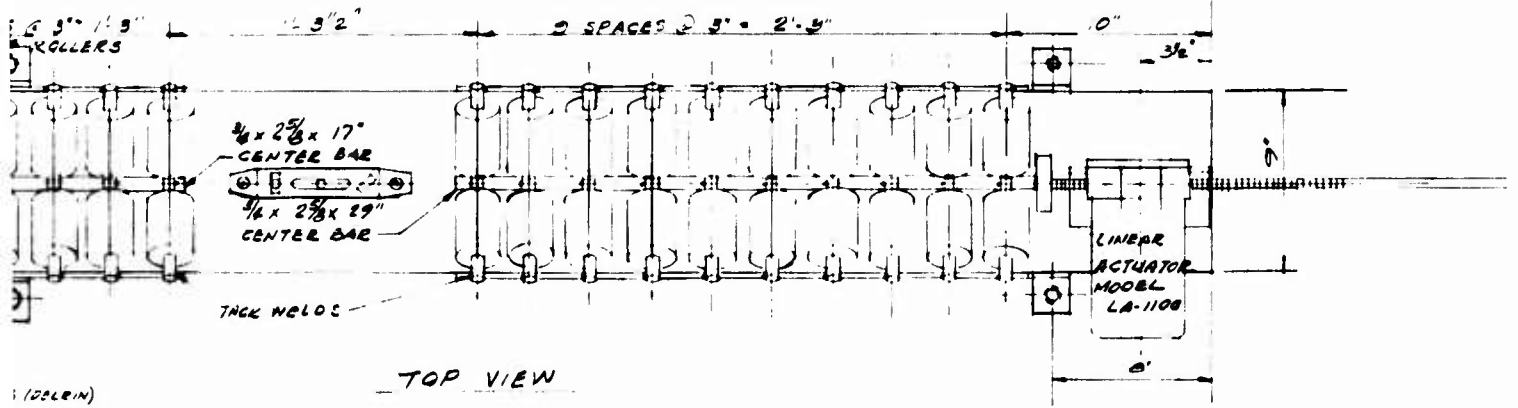

TOP VIEW

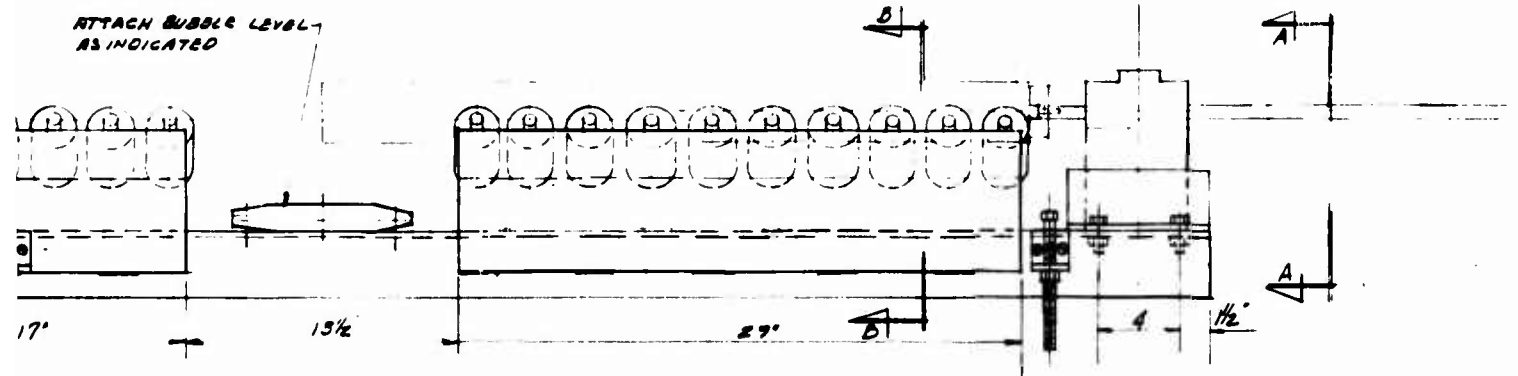

SIDE VIEW

**ROLLER CONVEYOR
FOR 3-IN. AND 6-IN.-DIAM
SOIL SAMPLE SCANNING
CALIFORNIUM**

ALUMINUM MAT'L
THRUOUT EXCEPT AS NOTED
EST. TOT. WT. = 128 #

In accordance with ER 70-2-3, paragraph 6c(1)(b), dated 15 February 1973, a facsimile catalog card in Library of Congress format is reproduced below.

Lewis, Jack T

Design and potentials of the californium-252 radiation facility at WES, by Jack T. Lewis and Ellis L. Krinitzsky. Vicksburg, U. S. Army Engineer Waterways Experiment Station, 1975.

1 v. (various pagings) illus. 27 cm. (U. S. Waterways Experiment Station. Miscellaneous paper S-75-26)

Prepared for Office, Chief of Engineers, U. S. Army, Washington, D. C., under Project No. 4A061101A91D.

Includes bibliography.

1. Californium-252. 2. Gamma radiation. 3. Laboratories. 4. Neutron radiation. 5. Radiography. 6. Rock properties. 7. Soil density. 8. Soil moisture. I. Krinitzsky, Ellis Louis, joint author. II. U. S. Army. Corps of Engineers. (Series: U. S. Waterways Experiment Station, Vicksburg, Miss. Miscellaneous paper S-75-26) TA7.W34m no.S-75-26