

AD _____

USAARL Report No. 76-5

OBJECT VISIBILITY PATTERNS IN LOW LEVEL FLIGHT

By

Robert H. Wright

&

J. Nicholas DeBonis

September 1975

Final Report

This document has been approved for public release and sale;
its distribution is unlimited.

U. S. ARMY AEROMEDICAL RESEARCH LABORATORY

Fort Rucker, Alabama 36362



NOTICE

Qualified requesters may obtain copies from the Defense Documentation Center (DDC), Cameron Station, Alexandria, Virginia. Orders will be expedited if placed through the librarian or other person designated to request documents from DDC (formerly ASTIA).

Change of Address

Organizations receiving reports from the U. S. Army Aeromedical Research Laboratory on automatic mailing lists should confirm correct address when corresponding about laboratory reports.

Disposition

Destroy this report when it is no longer needed. Do not return it to the originator.

Distribution Statement

This document has been approved for public release and sale; its distribution is unlimited.

Disclaimer

The findings in this report are not to be construed as an Official Department of the Army position unless so designated by other authorized documents.

UNCLASSIFIED

SECURITY CLASSIFICATION OF THIS PAGE(When Data Entered)

Relative angle of crossing linear features was determined, along with the duration that information of navigational value could be determined.

When over trees the actual masking function was grossly different from the theoretical curves, while over open terrain actual masking approximated the five percent cover theoretical curve at close range and the one percent curve at 1000 meters. Over trees, masking for tank-size vehicles ranged from 83 to 93 percent, and over open terrain from 10 to 77 percent masking. Only 12.5 percent of linear features were found to be oriented within plus or minus 30 degrees of the nose at crossing, while 58.3 percent were within plus or minus 30 degrees of perpendicular to the nose. This finding implies viewing to the sides as an aircraft crosses features is necessary in order to see the feature details that will provide positive geographic orientation. The detailed viewing along linear features required for positive geographic orientation was available for an average of 24 meters, or one second at 50 knots. Limited data are presented on the effect of altitude on duration of line of sight to objects that provide information of value in geographic orientation.

UNCLASSIFIED

SECURITY CLASSIFICATION OF THIS PAGE(When Data Entered)

SUMMARY

Line of sight viewing angle, range and time distributions are given for a 70 kilometer sample of tree-top level annular (fisheye) imagery, and comparisons made between these data and theoretical random single tree line of sight distributions. The effects of location over open and tree covered terrain are assessed, and limited data on the effect of altitude presented. Relative azimuth, elevation and range of objects when they first emerged into view were recorded by type of object. Relative angle of crossing linear features was determined, along with the duration that information of navigational value could be determined.

When over trees the actual masking function was grossly different from the theoretical curves, while over open terrain actual masking approximated the five percent cover theoretical curve at close range and the one percent curve at 1000 meters. Over trees, masking for tank-size vehicles ranged from 83 to 93 percent, and over open terrain from 10 to 77 percent masking. Only 12.5 percent of linear features were found to be oriented within plus or minus 30 degrees of the nose at crossing, while 58.3 percent were within plus or minus 30 degrees of perpendicular to the nose. This finding implies viewing to the sides as an aircraft crosses features is necessary in order to see the feature details that will provide positive geographic orientation. The detailed viewing along linear features required for positive geographic orientation was available for an average of 24 meters, or one second at 50 knots. Limited data are presented on the effect of altitude on duration of line of sight to objects that provide information of value in geographic orientation.

Approved:



ROBERT W. BAILE
Colonel, MSC
Commanding

TABLE OF CONTENTS

	<u>Page</u>
List of Illustrations.....	iii
Introduction.....	1
Masking in Theoretical Randomly Distributed Vegetation.....	1
Method.....	4
Imagery Reduction.....	6
Results and Discussion.....	9
Tree Cover of Route.....	9
Target Masking at Low Level.....	10
Azimuth of Feature Emergence.....	13
Elevation/Range of Feature Emergence.....	16
Relative Angle of Linear Features at Crossover.....	16
Navigation Information Viewing.....	21
Conclusions.....	26
Appendix A.....	A-1

LIST OF ILLUSTRATIONS

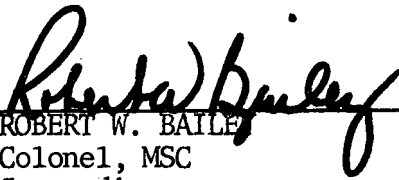
<u>Figure</u>	<u>Page</u>
1. Terrain masking as a function of range and density of randomly distributed trees.....	3
2. Example frame of the annular (fisheye) circular format motion picture imagery, as projected on the azimuth and elevation data reduction grid. The forward direction is located at the top of the image, and vertically downward is located at the center of the image.....	5
3. Grid used for determining relative azimuth and elevation of terrain features from annular imagery.....	7
4. Percent masking as a function of angle below the horizon.....	11
5. Percent masking as a function of range.....	12
6. Field masking data plotted on percent curves for randomly distributed trees.....	14
7. Relative azimuth at emergence.....	15
8. Angle below horizon at emergence.....	17
9. Range at emergence.....	18
10. Range at emergence for flying over open terrain or trees.....	19
11. Relative angle of linear features at crossover.....	20
12. Useful linear feature viewing times for navigational purposes as a function of altitude.....	22
13. Distribution of useful feature viewing times for navigational purposes at low level.....	23
14. Scenes illustrating emergence of a bridge from behind masking. Note angle below the horizon in excess of 45 degrees at emergence.....	25
A-1. Specifications and distortion curve for Kinoptik 1.9 mm f/1.9 Super-Tegea Lens.....	A-3

INTRODUCTION

What can a pilot see at nap-of-the-earth (NOE) flight levels? In what relative directions are features in view? In what elevations are they in view? How long are they in view? How far away are they when in view? How frequently and how long is line of view interrupted? With bare eyeballs on a pilot's swivelling neck, these aspects of nap-of-the-earth vision are of considerable interest in certain aspects of training and system design. However, with night vision systems, these basic relative geometry and time factors of NOE vision assume critical importance. With their narrow field of view and lack of peripheral cues the prospect of completely missing features and objects offset from the flight path becomes likely with night vision systems. Vegetation masking further aggravates the viewing problem by masking even objects directly under the flight path until the aircraft gets quite close to them, where large depression angles of line of sight are required to detect and recognize them. Vegetation masking of offset objects results in even greater restriction in availability of line of sight to them.

The quantification of masking of ground targets/features is an important factor in the definition of optimally effective nap-of-the-earth aircraft systems and tactics, and sufficient quantified information has not been available to meet these system definition needs. Sensor systems that image only a small percentage of objects/features within line of sight, or that can't be aimed quickly at an object/feature before it passes back behind masking, could be expected to have rather minimal operational effectiveness. Yet it appears NOE masking characteristics may produce such consequences for typical sensor system designs.

In a review of ground target masking research literature, Burge and Stohler (1974) concluded that "there is not nearly enough data accumulated to meet the needs of users," and that "field measurement is the best way of determining target masking." The data presented in this report are intended to contribute to reducing this data gap, with particular emphasis on the terrain features available for orientation in low level and NOE navigation.

MASKING IN THEORETICAL RANDOMLY DISTRIBUTED VEGETATION

For various reasons, vegetation "clumps" in most types of terrain rather than occurring on a single tree randomly distributed basis. Although examples of single tree random appearing vegetation exist to some degree in all types of terrain, a large portion of the terrain of potential operational interest has marked "clumping" of vegetation

due to natural or man-made influence on growth patterns. In natural settings vegetation is denser where greater supplies of water are available, such as along streams, and tends to be less dense along high points and steep slopes. Man tends to lay bare the ground by cutting all vegetation from geometric shaped fields, and to introduce straight-line patterns in field edges and man-planted vegetation.

Nevertheless, there is a common thread implicit in much air-to-ground intervisibility modeling that vegetation distribution is at least "quasi-single-tree-random." Therefore a single tree random distribution model needs to be considered as a point of reference for comparison of real world data with model assumptions. In particular, deviations of actual masking distributions in comparison to random distribution assumptions should provide a test for validity of model assumptions of random distribution.

Figure 1 shows the percent of terrain masked from view as a function of distance from viewpoint and the percentage of randomly distributed "trees." There is some roughness to these empirically determined curves due to the limited number of samples (4) used for estimation. They were determined by assuming a viewing point at or below tree-top height on a graph paper plot, and randomly filling in the required percentage of divisions of a 1000 by 1000 meter grid. The "trees" were assumed to be 10 meters by 10 meters in size and square in form, or to fill a one division unit on the graph paper. The masking behind each "tree" was drawn in from the viewing reference point. Arcs at various distances from the viewpoint were then drawn, and the percentage of that arc in view and behind masking measured.

It may be seen in Figure 1 that for the flat terrain assumed, for tree densities of ten percent or more, there is 98 percent masking at 200 meters, and masking is virtually complete beyond 300 meters range. For five percent cover, 98 percent masking exists at 500 meters and is complete by 700 meters, and for two percent cover masking is 70 percent at 500 meters and 90 percent at 1000 meters. Even for one percent tree cover masking exceeds 65 percent at 1000 meters. It may be observed the masking curves are not linear at the highest tree densities, with the percent of masking increasing very rapidly for the first 50 to 100 meters of range, and then increasing more slowly as range increases further.

These theoretical vegetation masking curves indicate the severe masking that should be expected even with small percentages of tree cover. Extrapolation of the two percent cover curve to three kilometers, for example, would indicate virtually complete masking at this range for this relatively sparse tree density. For tree densities above ten percent, which could be expected in most non-desert temperate and tropical regions, masking is virtually complete at ranges beyond

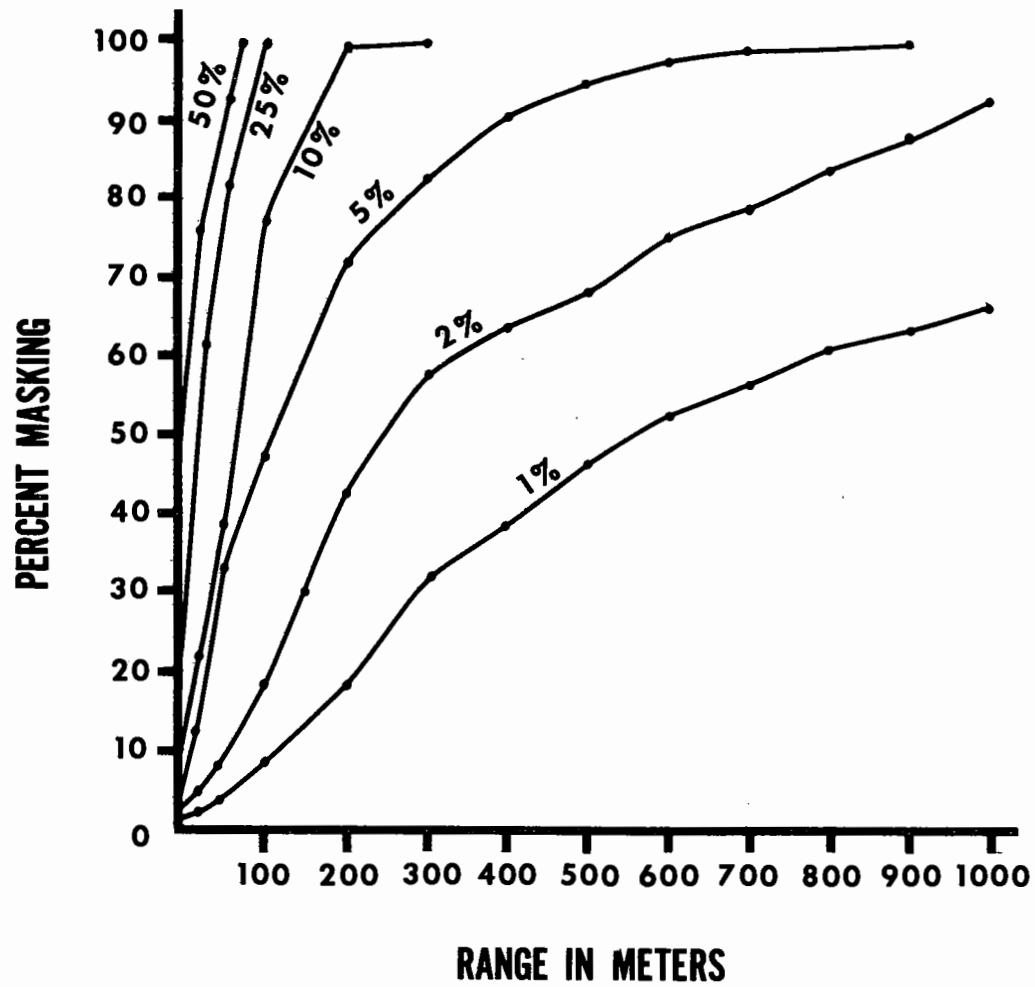

FIGURE 1. TERRAIN MASKING AS A FUNCTION OF RANGE AND DENSITY OF RANDOMLY DISTRIBUTED TREES

200 meters. Unless the assumption of random tree distribution is completely without foundation, the curves of Figure 1 indicate that at NOE little target visibility should be expected beyond 100 to 200 meters on a random basis. Certainly line of sight to a target beyond two or three kilometers would be expected to have virtually zero probability on a random basis.

The apparent conflict of these random tree distribution masking curves with operational and test results reporting much greater target detection ranges; suggests that real world terrain, or target search in it, may deviate substantially from a random model. It is reasonable to expect that aircrews flying NOE, searching for targets, exploit the non-random characteristics of the terrain in a manner that will optimize their visual search effectiveness. Adoption of good vantage points or paths should be routine operational procedures: aircrew's behavior should involve seeking out certain of the least random line of sight situations for the terrain in the area.

METHOD

The data reported here are based on analysis of some existing annular (fisheye) motion picture imagery obtained in the Fort Rucker area. The imagery was taken with a Milliken 16 mm motion picture camera (Model DBM 5AT) set at 24 frames per second with a Kinoptik 1.9 mm, f/1.9, 197 degree field of view lens. It was rigidly mounted to the frame of an Army H-13 helicopter in a manner such that the lens was located at the pilot's normal eye position. The lens was aligned so the optical axis was pointed vertically downward at a cruising speed of 50 knots. This resulted in a ground distance per frame of approximately one meter (1.072 meters exactly) under no wind conditions, and this factor is used in subsequent sections whenever the imagery frames are translated into ground distances.

The orientation of the lens resulted in the horizon appearing as a centered circle 8 1/2 degrees from the edge of the circular format image. (See Figure 2.) View to the horizon was blocked by the airframe to the rear, by the pilot to the right rear, and to some extent by the instrument panel and door framing. Filming was done with the doors off. Downward visibility was limited by seat, floor, and instrument panel structure to different degrees.

The pilot had instructions to maintain a smooth level attitude flight profile with obstacle clearance of five to fifteen feet, and the lower clearance value was generally flown. An absolute altimeter was not available for exact determination of ground clearance. Considering typical tree heights along the route, an average ground clearance

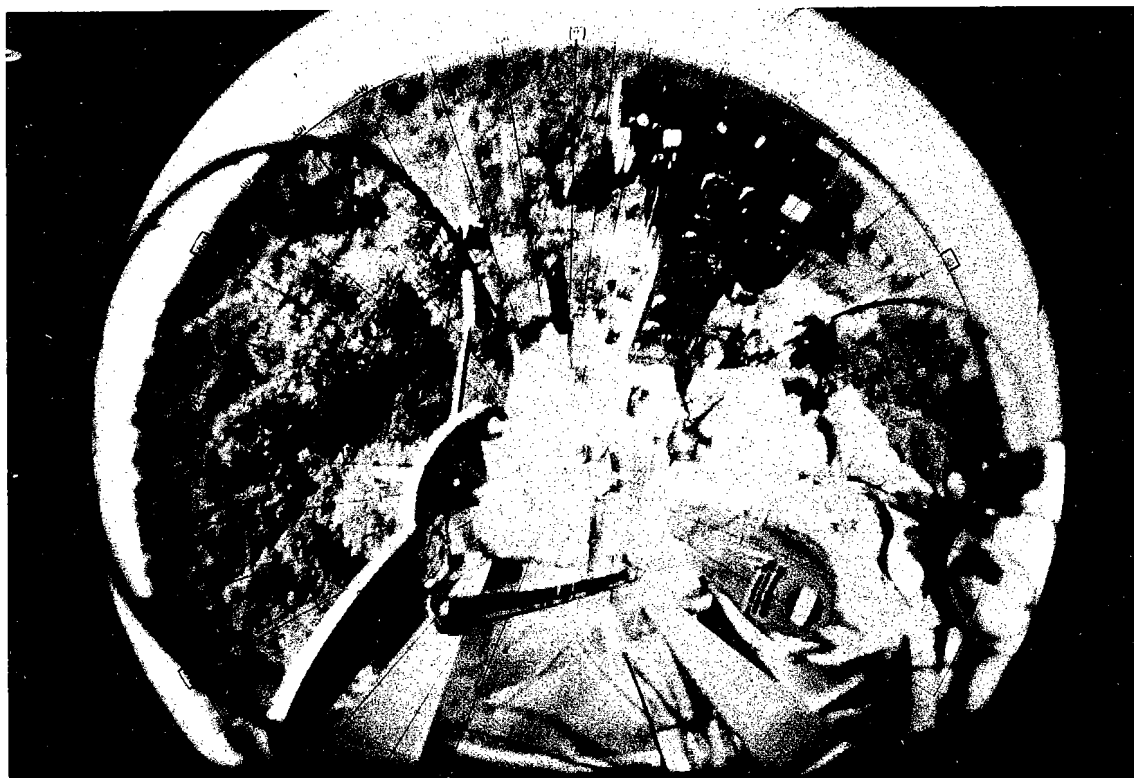

Figure 2

Example frame of the annular (fisheye) circular format motion picture imagery, as projected on the azimuth and elevation data reduction grid. The forward direction is located at the top of the image, and vertically downward is located at the center of the image.

height of 20 meters (65.6 feet) has been assumed for analysis purposes in this report. Over open fields this clearance frequently may have been reduced to 5 to 15 feet above the ground. Reduction in height over fields varied with the size of the field, with less reduction over small fields.

The actual route flown began on the Fort Rucker reservation at the southern tip of Lake Tholocco, and ran in a generally southward course that ended at a point slightly south of US Highway 90 about five kilometers west of Bonifay, Florida. The UTM coordinates for key points along the route were as follows:

Start Point (South edge of Lake Tholocco)	16R FK 218726
Cross Dirt Road to Hanchey AAF	FK 266681
Cross AL 134	FK 273656
Cross Little Choctawhatchee	FK 276602
Cross US 84	FK 291567
Cross AL 123	FK 282441
Cross AL 52	FK 288420
Cross AL 123	FK 283308
Cross L & N RR	FK 274289
Cross FL 2	FK 265256
Enter Wrights Creek	FK 258160
Cross FL 177	FK 247152
Cross US 90	FK 225078
End Point (tree in field)	FK 227064

The low level route was approximately 70 kilometers in length. In addition, the northern ten kilometers of the route over the Fort Rucker reservation were reflown at ground clearance heights of 61, 153, and 306 meters (200, 500 and 1000 feet). The coordinates for the end of the reflown route segment were FK 278665. This reflown route segment was used to obtain some preliminary data on differences in feature visibility as a function of ground clearance height.

Imagery Reduction. A special angular grid was drawn for reducing the imagery, consisting of azimuth angles in a compass rose format with 0/360 at the top (see Figure 3). Elevation angles below the horizon were represented by a set of evenly spaced concentric circles, with 90 degrees, or vertical downward, indicated by the center of the circles. The 16 mm motion picture projector was located at a distance and aimed so as to align the image horizon on the outer circle. If attitude changes caused the image to shift from this alignment, necessary aiming corrections were made to conform with the centered position. The locations of features were recorded using the angular grid as a reference in terms of relative azimuth (RA) with respect to the nose of the helicopter, and angle of depression (AOD) below the horizon. Frame count at each measurement point was taken to obtain a measure of time or distance.

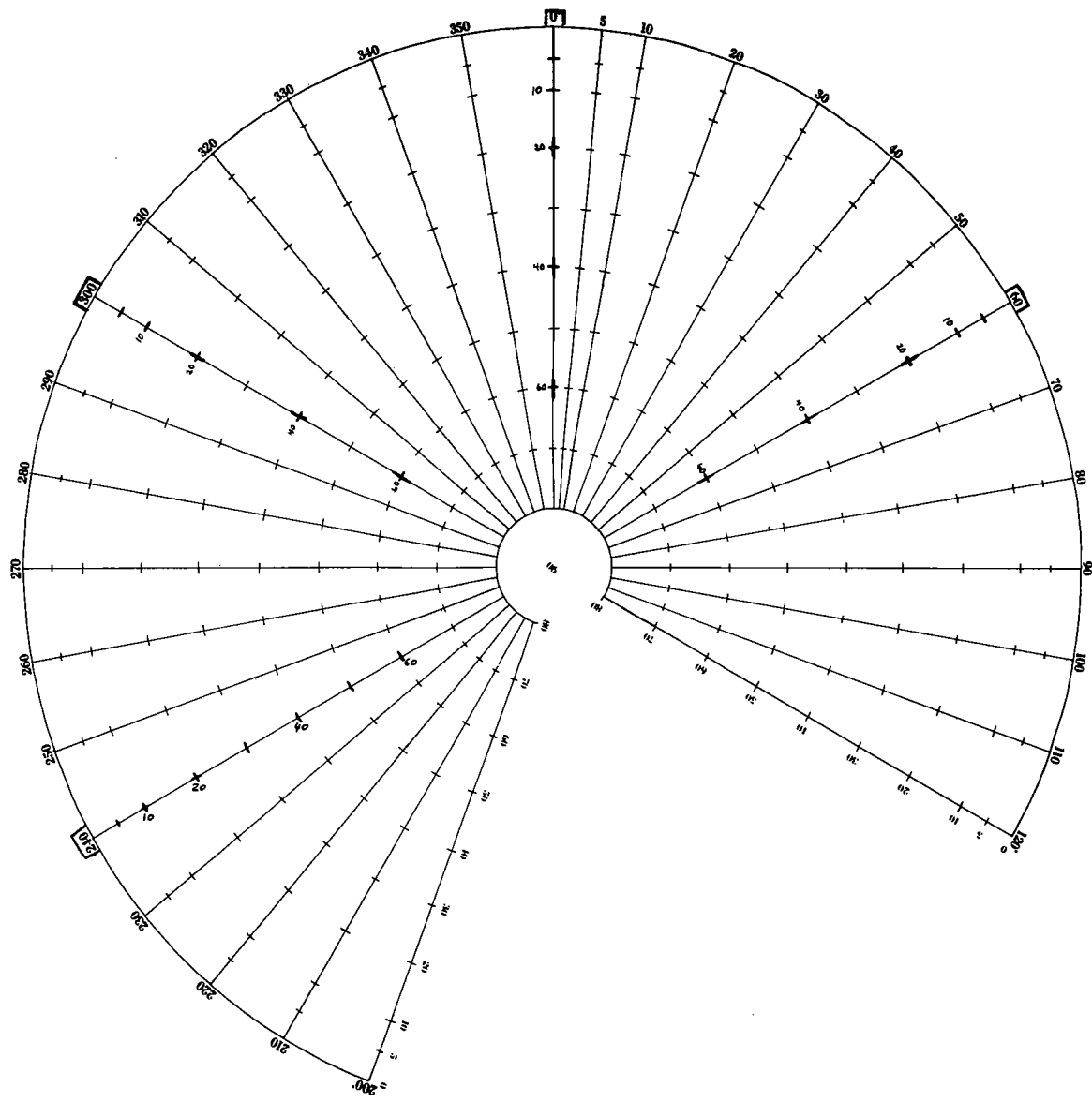

Figure 3.

Grid used for determining relative azimuth and elevation of terrain features from annular imagery.

Non-linearities of the lens have been corrected in the data presentations in this report. Appendix A presents the distortion curve and the correction factors used.

The following measures were obtained from the imagery.

1. Frame count when crossing from vegetated to open area.
2. Frame count when crossing from open to vegetated area.
3. Type of feature seen, such as roads, buildings, streams, etc.

For each feature seen:

4. Frame count at emerge.
5. Azimuth of nearest point at emerge (on one side of longitudinal feature).
6. Elevation of nearest point at emerge (on one side of longitudinal feature).
7. Azimuth at emerge for other end of longitudinal feature that all appears at about the same time.
8. Elevation at emerge for other end.
9. Frame count at feature crossing.
10. Relative angle at feature crossing.
11. Frame count when feature characteristics usable for navigation (CUFN) can first be seen (for longitudinal features).
12. Frame count when feature characteristics usable for navigation (CUFN) can no longer be seen (for longitudinal features).
13. Frame count when feature is last seen or passes behind 90-270 degrees relative azimuth.
14. Azimuth when last seen or passing 90-270.
15. Elevation when last seen or passing 90-270.

Every 500 frames (every 500 meters):

16. Line of sight masking for a tank-sized vehicle (L x W x H = 7 x 3.5 x 2.5 meters) along the 240 degree relative azimuth line from 0 to 35 degrees angle of depression below the horizon.
17. Line of sight masking for a tank-sized vehicle along the 300 degree relative azimuth line from 0 to 55 degrees angle of depression below the horizon.
18. Line of sight masking for a tank-sized vehicle along the 0/360 degree relative azimuth line from 0 to 55 degrees angle of depression below the horizon.
19. Line of sight masking for a tank-sized vehicle along the 60 degree relative azimuth line from 0 to 55 degrees angle of depression below the horizon.

For line of sight masking records (measures 16, 17, 18 and 19), a graph line corresponding to elevation angle was drawn in where masking existed, and left open where line of sight existed. Four such graphs were obtained for each masking record frame, three from 0 to 55 degrees AOD below the horizon, and one from 0 to 35 degrees AOD.

The frame counts at crossing vegetation/open lines were used to determine the percent of the route flown over open and vegetated terrain, and whether the aircraft was over open or vegetated terrain when viewing each terrain feature. A loose criteria was used for defining vegetated areas--down to very lightly scattered trees.

The criterion for "feature characteristics usable for navigation" (CUFN) being obtainable from a feature was somewhat subjective, but capable of being consistently applied. The fact that some feature of a general type was being approached was not sufficient, but when specific characteristics of navigational value for point rather than line of position could be seen, the criterion was considered satisfied. Such characteristics included ability to discern curves along a road or stream, intersections or bridges along the feature, its relative angle, or elevation profiles along it. Generally, the feature "opened up" for inspection of detailed characteristics along its length when CUFN line of sight was recorded. The differences in frame counts at measures 11 and 12 were used to determine the times and distances that CUFN viewing was possible. It may be noted these times/distances usually were considerably less than the total times/distances some portion of the feature was in view.

Total feature time/distance in view was obtained by subtracting measure 4 from measure 13.

RESULTS AND DISCUSSION

Four types of navigational features are used in reporting most of the results: two linear types (1) roads, streams, railroads, (2) power lines not alongside roads; and two point types (3) houses/buildings and (4) intersections, ponds and bridges.

Tree Cover of Route. The percent of the route flown over tree vegetated areas is shown in Table 1. It may be seen that the Fort Rucker reservation segment had a higher degree of tree cover than the route as a whole, and that when flying low over Rucker, somewhat less vegetation was overflown than at the higher altitudes above the ground. Since the route generally followed stream lines, this percentage of tree cover should not be considered to be representative of the area as a whole. It represents the open-tree covered distribution of the actual path of the helicopter. It is characteristic of the area that open fields were likely to exist to both sides of the stream lines followed. The route

was more direct than current NOE flight paths, with less "tight" following of stream line masking. Stream lines were used when they were convenient, but straight line cross-country segments were used between stream lines if one wasn't "going our way."

Table 1
Percent of Route Flown Over Tree Vegetated Area

Fort Rucker Reservation Segment				
All Low	Low	61 Meters	153 Meters	306 Meters
		200 Feet	500 Feet	1000 Feet
60.6%	77.7%	91.8%	92.6%	90.7%

Target Masking at Low Level. Figure 4 presents the probability of target (tank sized; L x W x H = 7 x 3.5 x 2.5 meters, 23 x 11 x 8 feet) masking as a function of angle of depression (AOD) below the horizon, and Figure 5 as a function of estimated ground range from the helicopter. The flying "over open" terrain curve is based on 68 frames spaced at least 500 meters apart, the "over trees" curve is based on 107 frames spaced at least 500 meters apart. Four different viewing directions spaced 60 degrees apart are used for each frame from AOD's of 0 to 35 degrees, and three viewing angles from 35 to 55 degrees. This results in 428 data points for each "over trees" curve point from 0 to 35 degrees, and 321 data points from 35 to 55 degrees. For the "over open" curve the number of data points are 272 and 204 respectively.

No claim can be made that all the data points are truly independent. The four measurements on the same image frame should have considerable correlation, particularly at the higher AOD's. Adjacent (500 meter separation) analysis frames could be expected to be correlated somewhat, at least in greater degree than more distant frames.

It may be seen in Figure 4 that flying "over trees" has a substantial effect on the probability of a tank sized target on the ground being masked. When "over trees" a 93 percent probability of masking exists near the horizon, decreasing to 83 percent chance of masking at 53 degrees AOD. When "over open" fields target masking is 77 percent near the horizon, decreasing to 10 percent at 53 degrees AOD. It may be noted the slight dip in the "over trees" curve from 1 to 5 degrees AOD probably represents the first adjacent field.

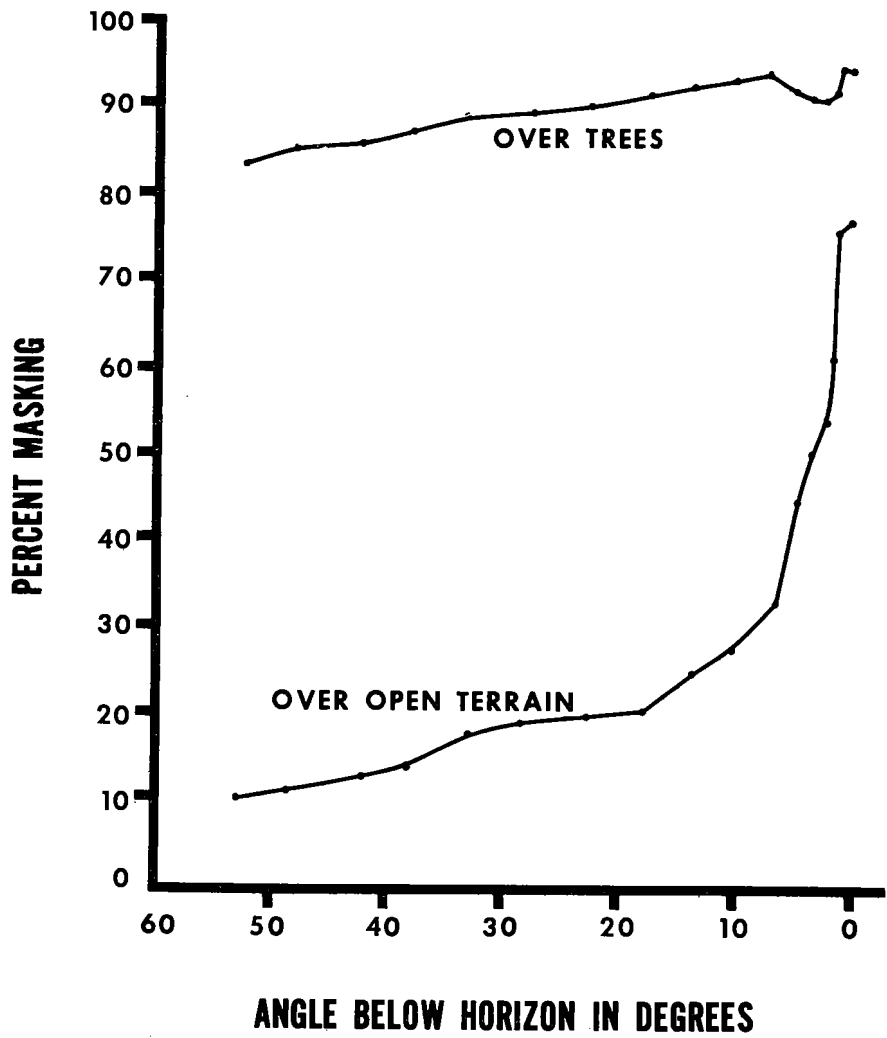

FIGURE 4. PERCENT MASKING AS A FUNCTION OF ANGLE BELOW THE HORIZON

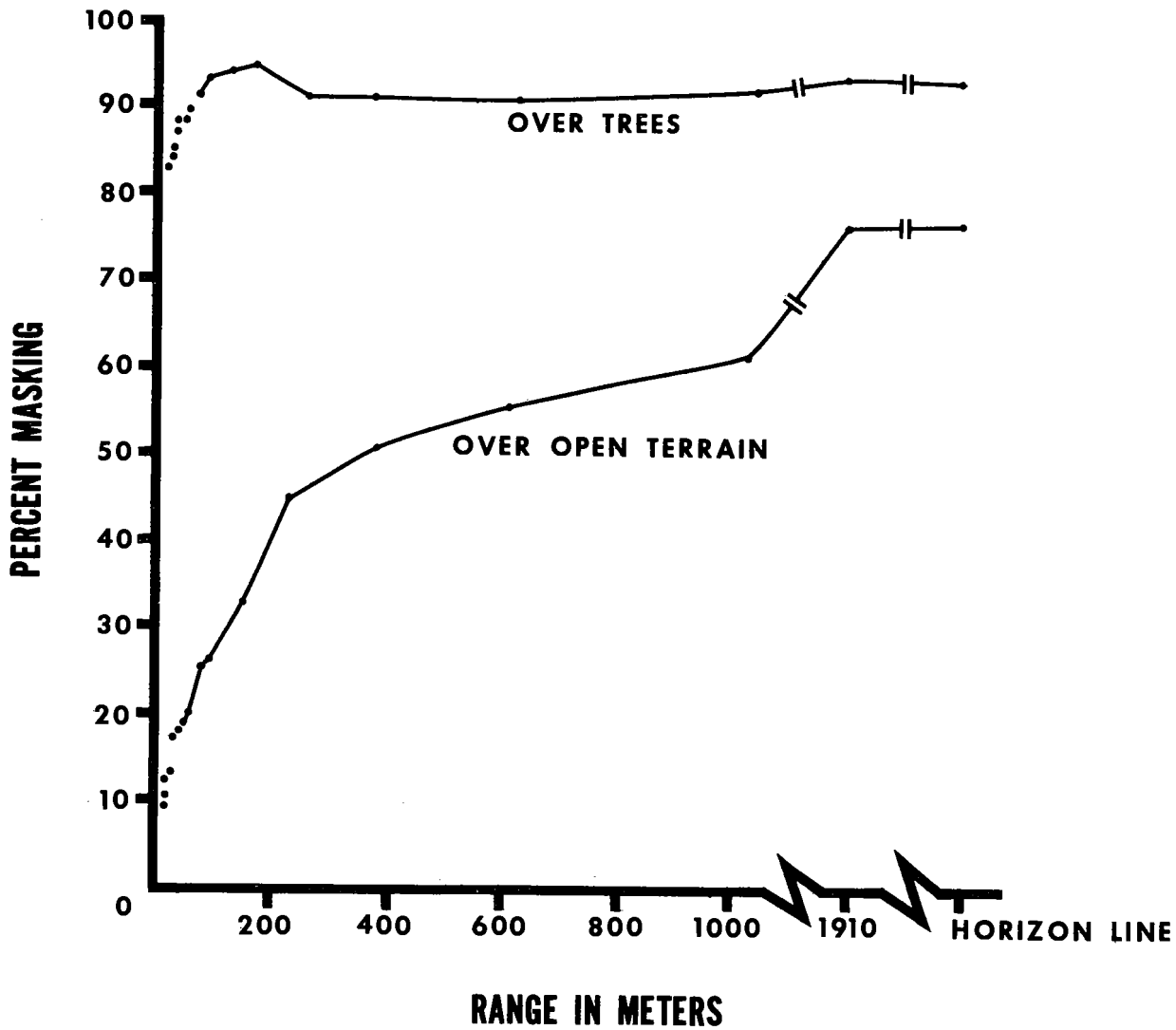

FIGURE 5. PERCENT MASKING AS A FUNCTION OF RANGE

Figure 5 presents the same data as Figure 4 with the horizontal axis scaled in ground distance from the helicopter using a co-tangent transform of the AOD with an assumed height of 20 meters. It may be seen that the 1 to 5 degree "next adjacent field" dip in the "over trees" curve of Figure 4 occurs at only 150 meters distance and continues to about 1000 meters.

Figure 6 combines Figure 5 with the masking curves for randomly distributed trees of Figure 1. It may be seen that the "over trees" masking curve does not closely resemble any of the curves for randomly distributed trees, which it should match on a logical basis. However, the "over open" curve approximates the random tree curves between one and five percent. At close range, it is close to the five percent curve, while around 1000 meters it is close to the one percent curve. Although the match is not particularly close to any specific random tree distribution curve, the "open" field data has the general shape of the low percentage curves. The "trees" data, however, only resembles about a 75 percent tree density curve below 87 percent masking. In contrast to the theoretical random tree distribution curves, which proceed quickly to 100 percent masking, the actual field masking attenuates rapidly around 90 percent. It rests at 93 percent masking at 140 meters, dips back to less than 91 percent masking around 500 meters, and then increases back to 93 percent near the horizon. This odd function does seem to match the subjective impressions of distribution of line of sight when flying over stream line vegetation. Almost complete masking exists in the forward direction, but to the sides, the far sides of open fields can be seen beyond the stream line tree tops.

Azimuth of Feature Emergence. Azimuth at feature emergence was an approximately normal distribution centered on the nose of the aircraft (see Figure 7). For linear features that emerged almost simultaneously along their length, the closest clearly visible point was used for defining azimuth. It may be seen that about 50 percent of the features are first seen within ± 30 degrees of the nose, and about 75 percent within ± 45 degrees. Twenty-five percent are first seen at relative angles greater than 45 degrees off the nose. Differences in azimuth at emergence as a function of viewing from over open or tree covered terrain were not evident, but differences in number of features seen were found.

One might expect a greater proportion of features to be first seen while over open than while over vegetated terrain, but just the opposite was found. While 39.4 percent of the route was flown over open terrain, only 17.2 percent of the features on the route were first seen while over open terrain. Also, 60.6 percent of the route was flown over trees, but 82.8 percent of the features were first seen while over tree covered terrain. Considering the terrain, it seems probable that features in or near the edge of open areas were emerging into view while over vegetation, before the open areas were actually reached.

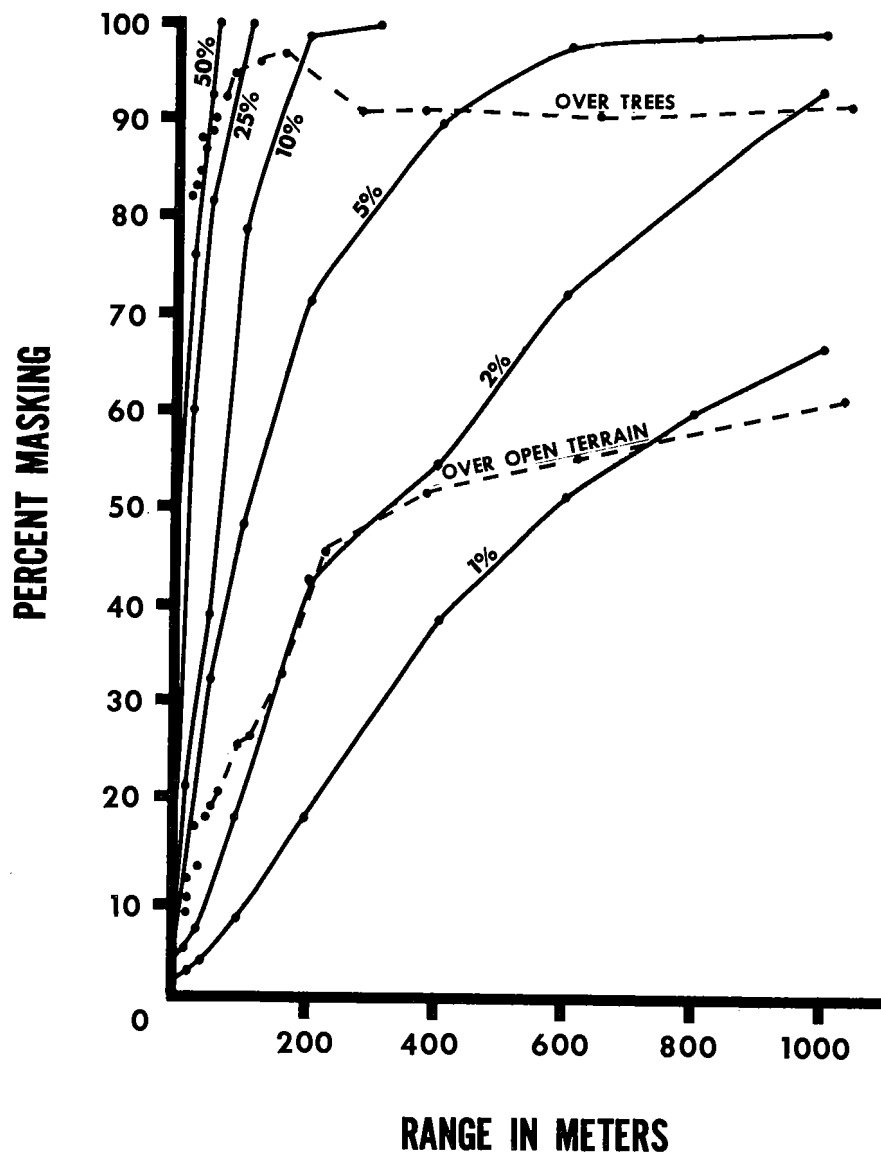

FIGURE 6. FIELD MASKING DATA PLOTTED ON PERCENT CURVES FOR RANDOMLY DISTRIBUTED TREES

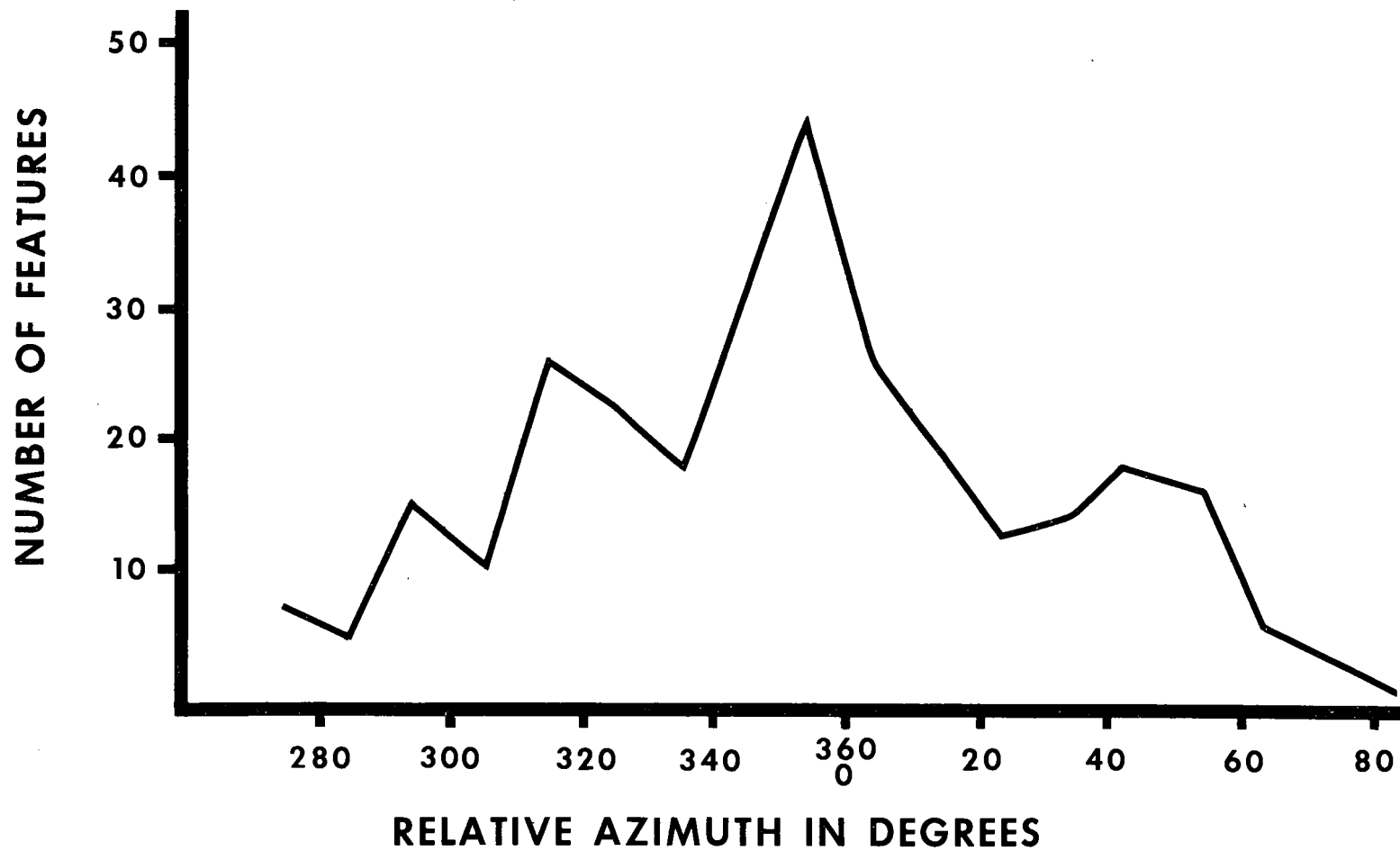

FIGURE 7.

RELATIVE AZIMUTH OF FEATURES
WHEN THEY FIRST EMERGE INTO VIEW

Elevation/Range of Feature Emergence. Figure 8 shows the number of features as a function of their angle below the horizon when they first emerged into view. It may be seen that most features emerged within about ten degrees of the horizon. Examining the cumulative percentage it may be seen that 75 percent of the features were within view within six degrees below the horizon, and 90 percent within 14 degrees.

When translated into range (see Figure 9) at emergence, however, it is found that 50 percent of the features emerge at less than 425 meters, 25 percent at less than 205 meters, and 10 percent at less than 80 meters.

Examination of Figure 10 indicates that more features emerge into view at longer ranges while over open terrain than while over trees, and that more features emerge at the shorter ranges while over trees.

It should be noted that details of value in point navigation or geographic orientation were seldom available at these first emerge angles/ranges. For linear features such as a road this first emerge range corresponded to some part of it having sufficient contrast that it would tend to "catch your eye" for continued more detailed examination. Most of the road would still be masked, and the detected contrast spot might turn out to be only a barren patch of ground. Only when a line of these contrast patches began to be evident could one start assuming a road was actually coming into view. Even then information of value in orientation usually could not be obtained. Generally one had to wait until the feature "opened up" very close to crossover before specific geographic orientation information could be obtained.

Relative Angle of Linear Features at Crossover. Figure 11 shows the relative angle of crossing of linear features (roads, streams, railroads and power lines). In this figure, the crossing angle is referenced to the right hand semi-circle of 0 to 180 degrees. A feature seen at crossover only in the 310 degree direction (due to airframe masking to the rear), for example, would be plotted as 180 degrees opposite, or at 130 degrees. It may be seen that the distribution of relative angles centers around 90 degrees, with relatively few features oriented within ± 30 degrees of the nose (0-30 or 151-180 degrees). Also, 58.3 percent of the crossover angles fall within ± 30 degrees of the perpendicular or 90 degrees, whereas only 12.5 percent fall within ± 30 degrees of the nose (4.2 + 8.3). This result seems to be surprising to aviators, although it is to be expected on a logical basis--features oriented in the same direction one is flying will be crossed less frequently than those oriented across the flight path. Since a large part of the information within view that potentially can be used for low level navigation is found along these linear features as they are crossed, their orientation distribution has major implications for the design of effective navigation sensors.

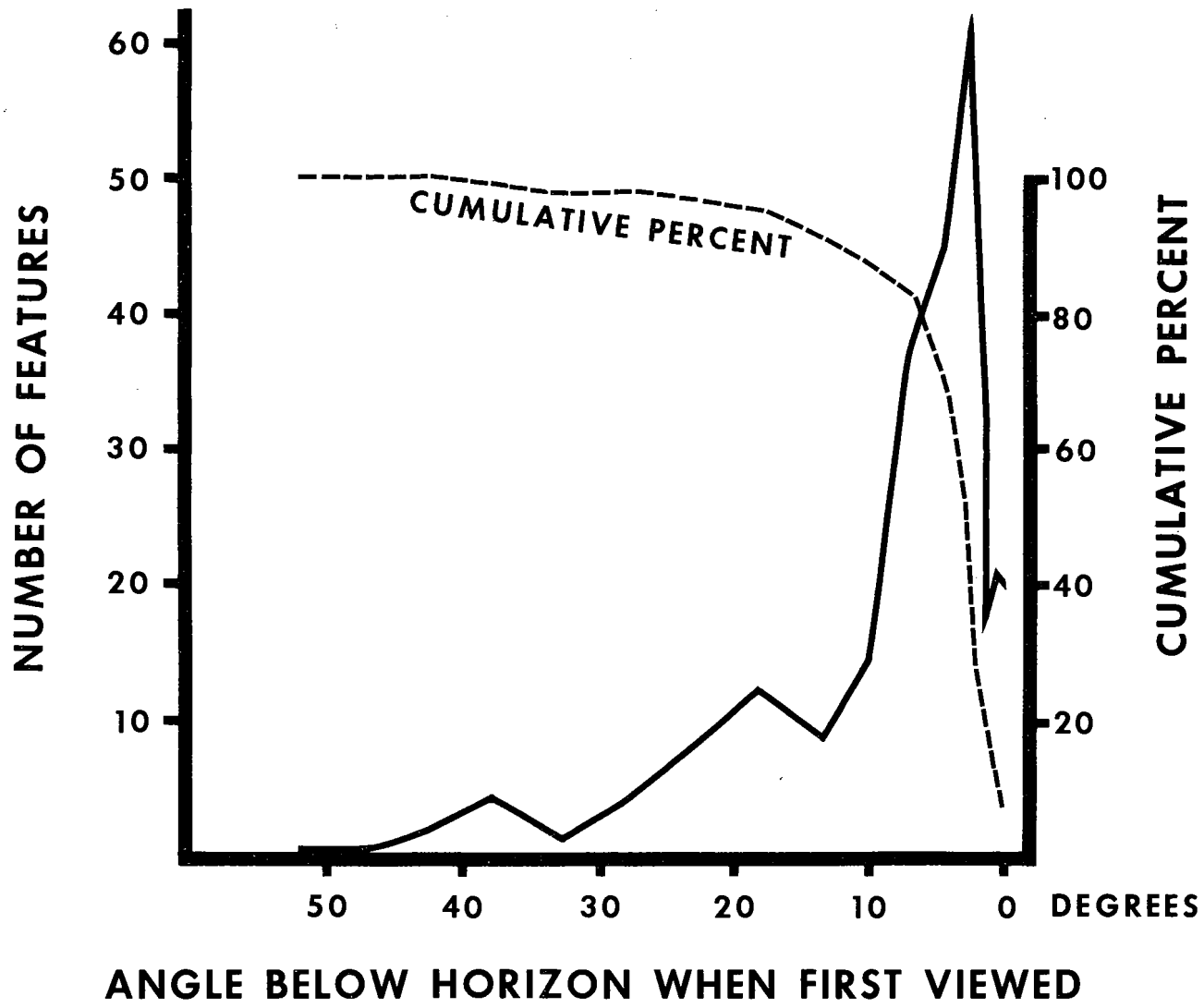
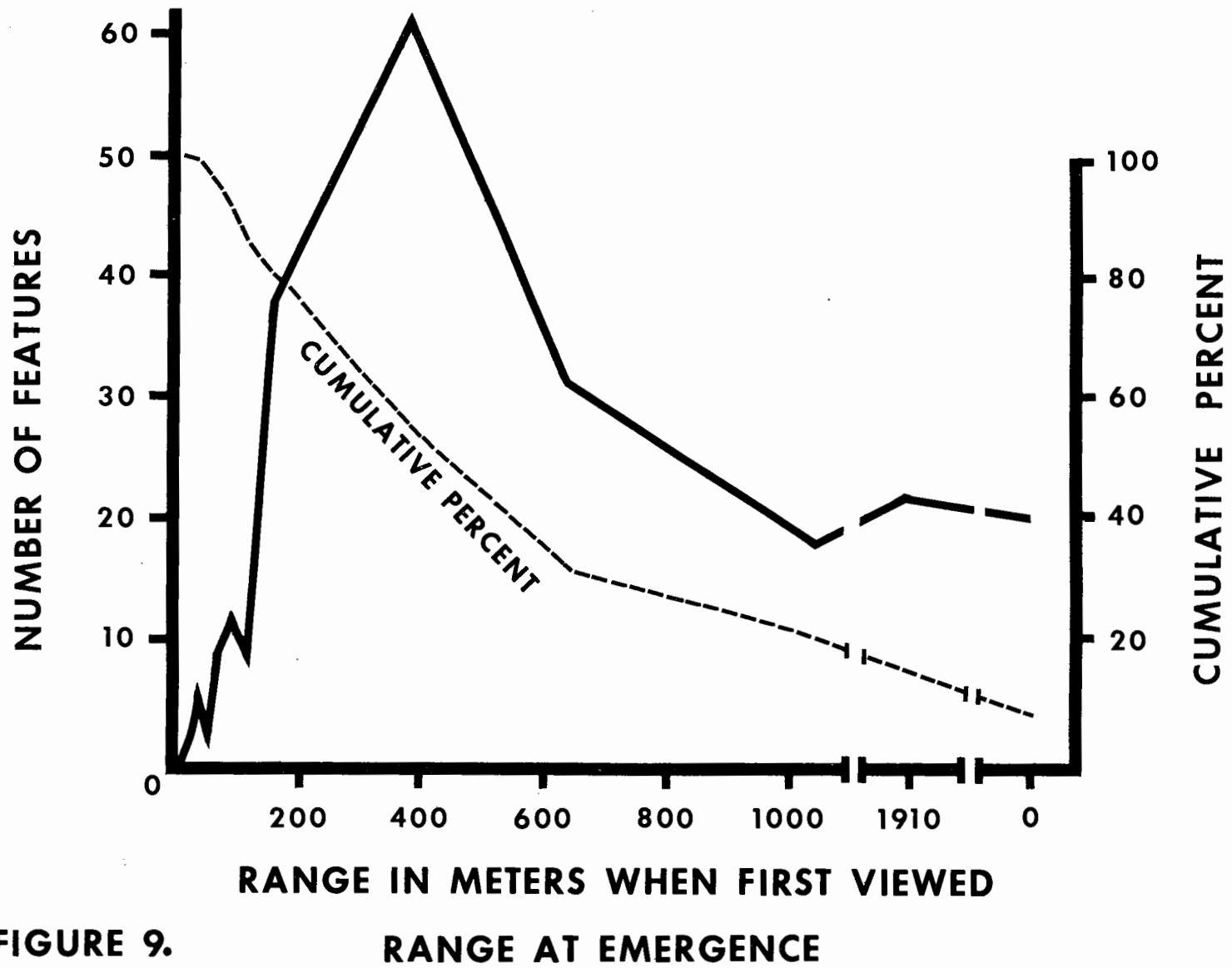

FIGURE 8. ANGLE BELOW HORIZON AT EMERGENCE



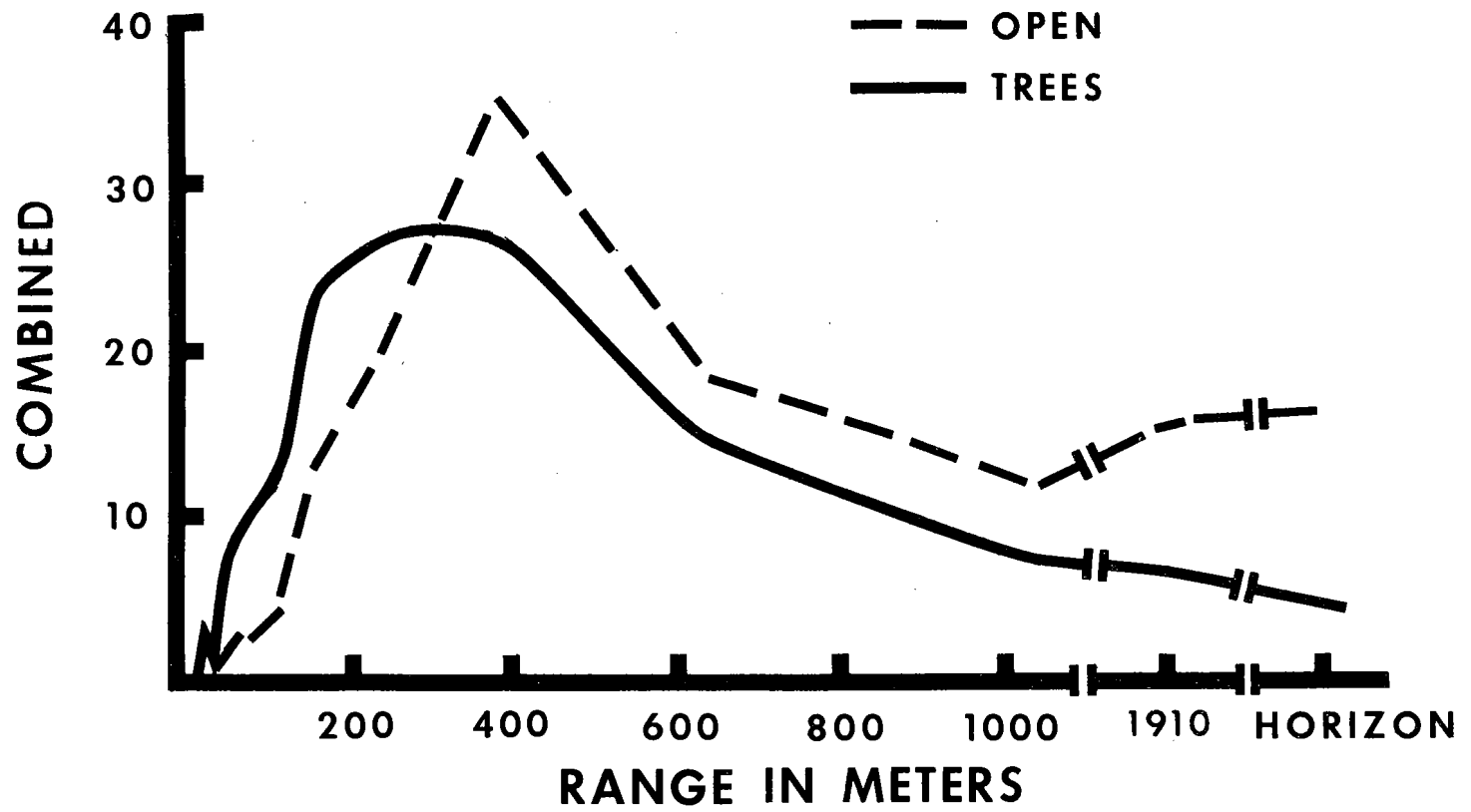

FIGURE 10. RANGE AT EMERGENCE FOR FLYING OVER OPEN TERRAIN OR TREES

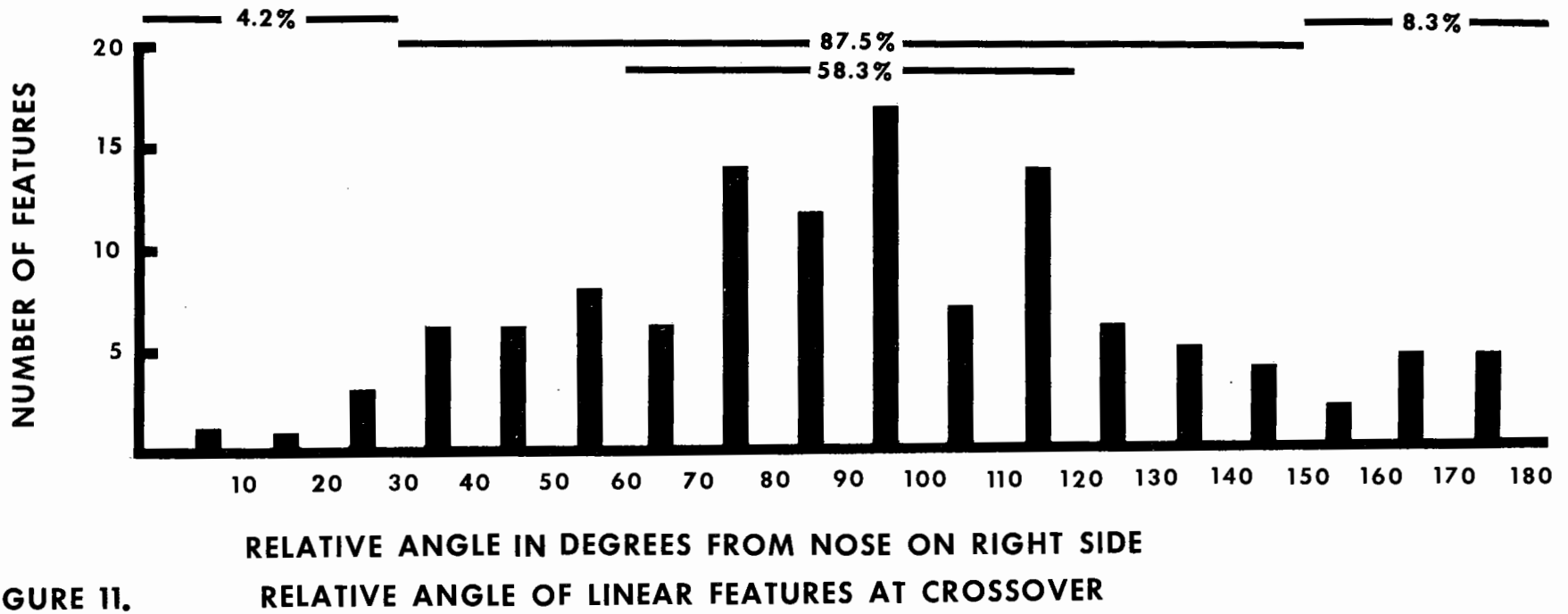

FIGURE 11.

Navigation Information Viewing. Figure 12 shows the viewing time and distance that linear features were in view in a manner that information of value in navigational orientation could be obtained from them. The number of features measured over the Fort Rucker segment were not sufficient to provide a high level of confidence in them, but are presented as a tentative basis of comparison. It is also likely the poor resolution of the edge of the lens may have limited the measured times in view at the two higher altitudes. It may be seen viewing times at 50 knots averaged about 20 seconds at 306 meters, about five seconds at 153 and 61 meters and one to three seconds at low level. From Figure 13 it may be seen that one single feature that was in view for navigational detail for 385 frames/meters tends to distort the average data in the Rucker segment low and "low all" graphs. Without this atypical value, the Rucker segment low and "low all" values would be 25 and 24 meters respectively, or a viewing time of one second.

For the entire low level route it may be seen this type of viewing opportunity was 21 meters or less for 50 percent of the features, and 41 meters or less for 90 percent of the features, with corresponding viewing times of 0.9 and 1.6 seconds at 50 knots. The 10 to 90 percentile range for the duration of this good navigational viewing was 10 to 41 meters, or 0.4 to 1.6 seconds. Although some information usable for detailed navigational orientation was otherwise available, most navigational information has to be obtained within these 10 to 40 meter "viewing gates" when crossing over a feature. At 25 knots, these 10 to 90 percentile "viewing gates" would exist for only 0.8 to 3.3 seconds, while at 100 knots they would exist for just 0.2 to 0.8 seconds.

Trying to inspect a dynamically changing scene at feature crossover for navigational information within the very short time periods imposed by NOE/low level flight is difficult with direct vision, and becomes nearly impossible with an indirect view sensor if delays are involved in its use. At best, one direction for looking must be selected prior to flyover, and the potential information in the opposite direction lost. The short times and dominantly sideward orientations involved suggest that some sort of bi-directional "snapshot" capability should be considered for an indirect view navigational sensor.

If two sensors are available, arranging for them to be properly oriented at feature crossover will be necessary, along with sufficient viewing time to be available for detailed inspection of the minute characteristics to be determined along the feature. With direct vision in daylight, the short viewing times at feature crossover dictate that definitive crew procedures be established with one responsible for

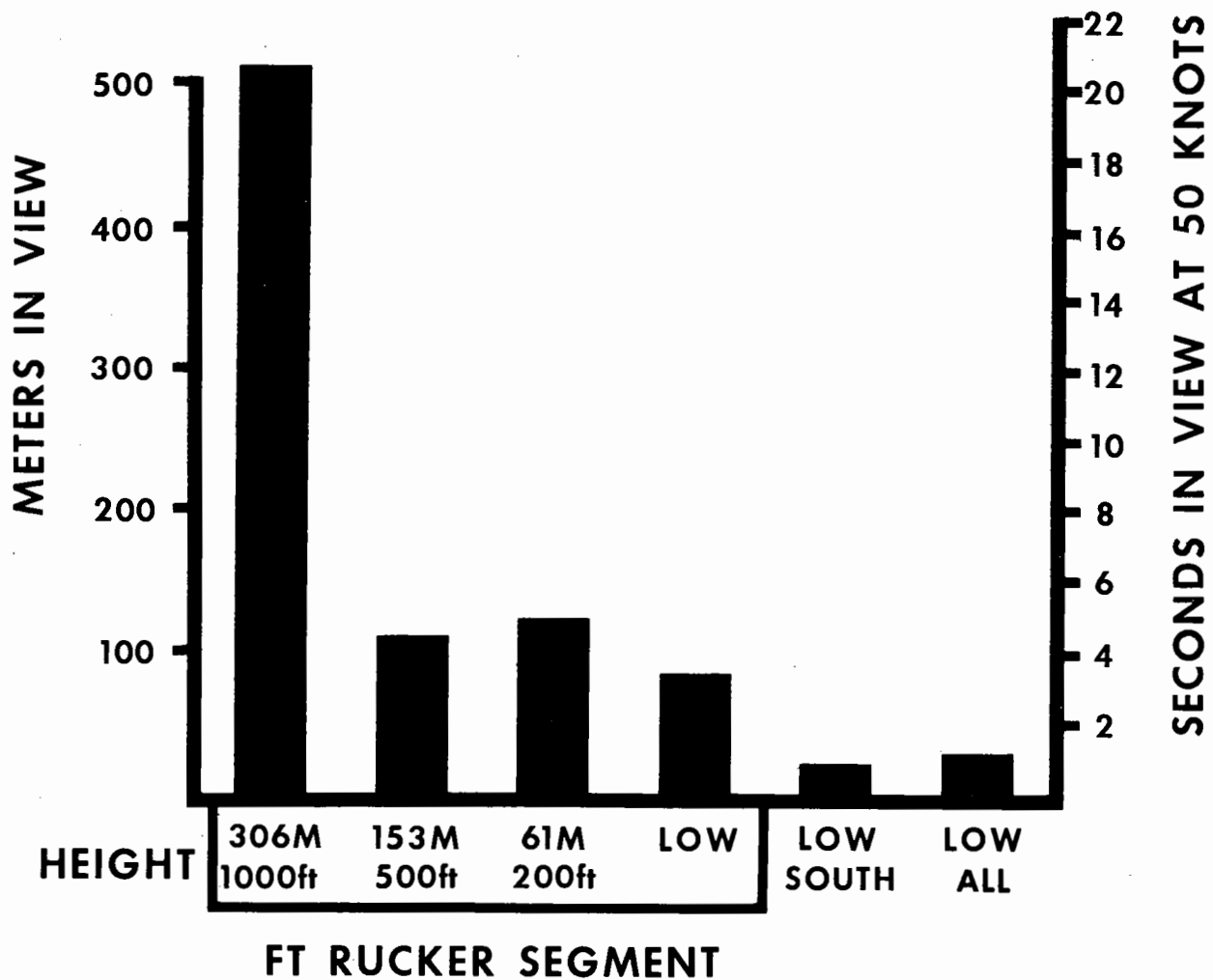

FIGURE 12. USEFUL LINEAR FEATURE VIEWING TIMES FOR NAVIGATIONAL PURPOSES AS A FUNCTION OF ALTITUDE

		Time Intervals in Seconds at 50 Knots										
		0-.20	.21-.40	.41-.60	.61-.80	.81-1.00	1.01-1.20	1.21-1.40	1.41-1.60	1.61-1.80	1.81-4.00	4.01+
Number Combined					19							
					18							
					18	23						
				14	18	24	28					
				12	16	23	28					
				11	15	23	25					
				10	15	20	28					
				10	15	20	28					
		9		10	18	20	28					
		8		14	18	24	27					
Number Over Trees	7				17	22	25		36			89
	6				17	22	25	30	39	41		64
	5				16	21	25	31	39	44		89
	8				15	21	25	30	37	43		63
												385
						50% = 21		80% = 30		90% = 41		
						19						
						18	23					
						18	24					
			14	18	23							
	9		12	18	23							
	8		11	16	23							
	7		10	15	20				36	41		
	6		10	15	20	28			39	44	89	
	5		10	15	20	25	30	39	43	64		
Number Over Open							28					
							28					
							28					
							28					
					18	24	27					
				14	18	22	25					
				14	17	22	25					
				14	17	22	25					
				11	16	21	25	31				89
		8		10	15	21	25	30	37			63
											385	
		0-4	5-9	10-14	15-19	20-24	25-29	30-34	35-39	40-44	45-100	100+
		Frames/Meters Intervals										

Figure 13.

Distribution of Useful Feature Viewing Times* for Navigational Purposes at Low Level

*Entries indicate frames in view while navigation details might be seen.

one side and the other responsible for the opposite side. The scene image at crossover needs to be remembered as a whole, and specific details noted. The non-navigator then needs to convey these details to the crewmember responsible for navigation in a clear manner. If time allows it is very desirable for the navigating crewmember to glance in both directions at feature crossover, in order to provide him with the best possible image of feature characteristics and spacing.

Given the generally south orientation of the route and tendency for roads crossed to run east-west, the peaking of crossing angle at 90 degrees is probably higher than would result from a random sampling of directions. If both road directions and flight directions were completely random, the maximum frequency of crossing angles should still peak at 90 degrees, but the spread and slope of the distribution should be broader and more gradual. The dynamic geometry of features with regard to the flight path, however, clearly dictates that features running across the flight path will be encountered more frequently than those that run in the direction of the flight path.

The short viewing ranges where high probability of unmasked line of sight exists have consequences both for navigation and target acquisition sensors and tactics. For longer range acquisition to occur, vantage points which minimize masking of the area of interest must be exploited. If areas having even small percentages of tree cover must be searched, then shorter ranges and steeper downlook angles need to be used for search. As the tree density increases, search range will have to be reduced and downlook angle increased even further. Any sort of intelligence that can reduce the degree of completely random searching should improve detection probabilities considerably. However, considering the common exploitation by both vehicles and individuals of the concealment vegetation provides, and the trend for tree-covered stream-line following by helicopters, steep downlook angle short range target detection seems essential for both navigation and target acquisition. When the enemy is in defensive or retrograde postures, the necessity for this steep angle/short range search pattern will probably be much greater than when he is on the offense.

Figure 14 shows two scenes that illustrate the masking situation when one is fortunate enough to fly almost directly over a checkpoint. It may be noted the bridge in front of the left skid is about 45 degrees below the horizon before it clearly comes into view from behind masking. Although some bridges or intersections that might be good checkpoints were in view at longer ranges, the masking in this scene is less than that which was typical for dirt roads along stream lines in the area. For a typical forward oriented wide angle sensor, it is likely this bridge would not have been imaged at all, or only for a fraction of a second in the lower edge of the image before it passed from view. The

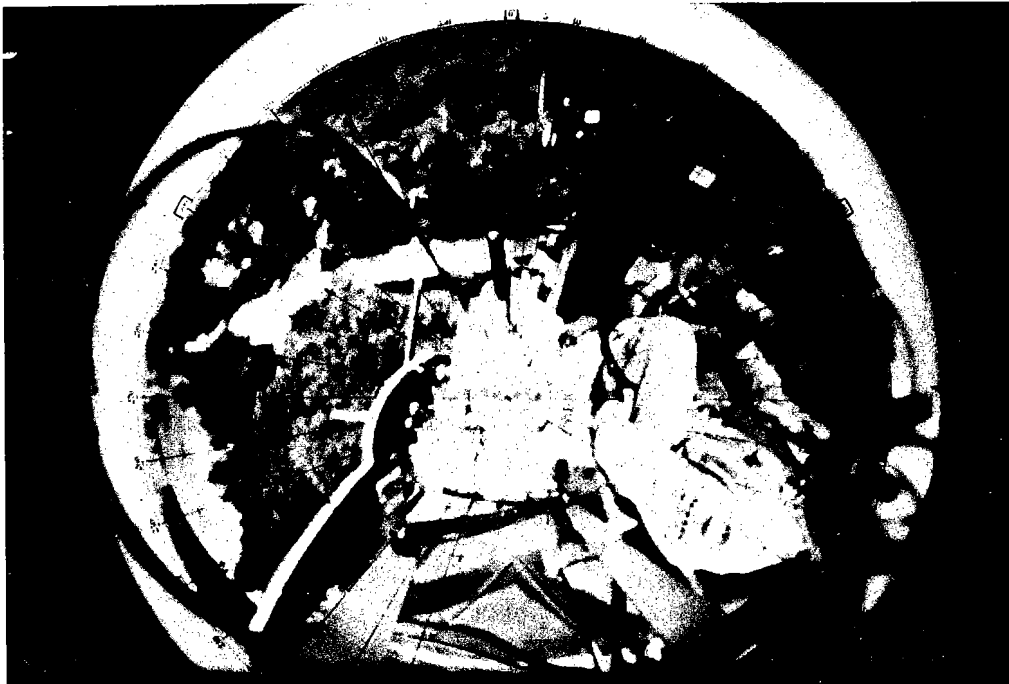

Figure 14.

Scenes Illustrating Emergence of a Bridge from Behind Masking. Note Angle below the Horizon in excess of 45 Degrees at Emergence.

vegetation masking situation results in it only being in line of sight at steep viewing angles of 45 degrees or greater. Finding some way for aviators to see such features with sensors at night would seem to be an essential element of effective night NOE navigation with current navigation techniques.

CONCLUSIONS

1. It is necessary to view to the sides of a helicopter as a linear feature such as a road is crossed in order to see the feature details that will provide positive geographic orientation. Only 12.5 percent of linear features were found to be oriented within plus or minus 30 degrees of the nose at crossover.

2. At crossing linear features opened up to allow line of sight to geographic orientation clues along them for short periods. The 10 and 90 percentile values for this viewing opportunity were 10 and 41 meters respectively, or 0.4 and 1.6 seconds at 50 knots. Median distance open for view at crossing was 21 meters, corresponding to 0.9 second at 50 knots, or less than one-half second at 100 knots.

3. For 50 percent of features, the first portion of the features to become visible from behind masking emerged at less than 420 meters, and for 25 percent of features at 200 meters or less. The corresponding angles below the horizon at emergence were three degrees for 50 percent of features, and six degrees or more for the closest 25 percent of features at emergence.

4. Azimuth at emergence centered about the nose, with 25 percent within ten degrees of the nose, 50 percent within 25 degrees, 75 percent within 45 degrees, and 90 percent within about 60 degrees of the nose.

5. While over trees, masking for tank-type targets ranged from 83 percent at 15 meters range/55 degrees below the horizon, to 93 percent at 150 meters range/7 degrees and also 93 percent at 2000 meters/0.6 degree or farther. At intermediate ranges masking dipped slightly to 90.5 percent. While over open terrain masking ranged from 10 percent at the corresponding close ranges or angles, to 77 percent at 2000 meters or longer ranges.

6. Functions obtained for actual masking did not closely match theoretical masking functions for randomly distributed trees. When over trees, the actual masking function was grossly different from the theoretical curves, which rapidly reached 100 percent while actual masking peaked at 93 percent. When over open terrain, the actual masking function approximated the random tree cover curves between one and five percent. At close ranges of less than 100 meters, the actual function approximated the five percent random tree curve, while at 1000 meters, it approximated the one percent curve.

APPENDIX A

Lens specifications, distortion and correction factors are given in Table A-1 and Figure A-1.

The distortion of the Kinoptik 1.9 mm f/1.9 Super-Tegea Lens was corrected in determination of elevation angles. Since the imagery was initially reduced using linear angular assumptions with the horizon as reference (the horizon was shifted to center it on the horizon reference circle), the 90 degree off optical axis value on the distortion curve was used as the basis of correction. A straight line was drawn from the origin to the 90 degree value curve intercept, and the differences between this line and the distortion curve used to determine the degrees of angular correction required.

Table A-1
Angle Shifts

Image Linear Angle Below Horizon	True Angle Below Horizon	Correction Factor	Estimated Range Using Cotangent Conversion & Assumed 20 Meter Height
0	0	0	
1	.6	.4°	1910
2	1.2	.8°	1042
3	1.8	1.2°	636.4
5	3.0	2.0°	382
8	4.8	3.2°	238.2
11	7.0	4.0°	162.9
14	10.0	4°	113.4
18	14.0	4°	80.2
23	18	5°	61.5
28	23	5°	47.1
33	28	5°	37.6
38	33	5°	30.7
43	38	5°	25.5
48	43	5°	21.4
53	48	5°	18.0
58	53	5°	15.7

A-3

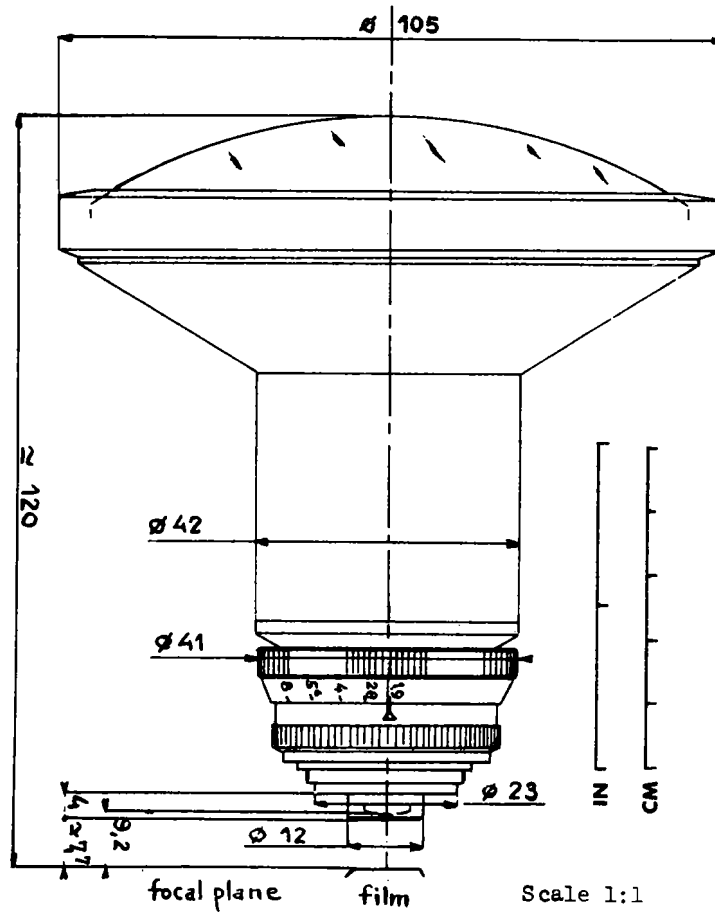

Angle of view 197° (on 8.7mm diam. circle)
 Aperture $f/1.9 - f/22$
 Photometric Aperture $T/2 - T/22$
 Focusing range (fixed focus) infinity to front element
 Distortion see curve below
 Optical back focus 9.2mm
 Weight 26 oz.

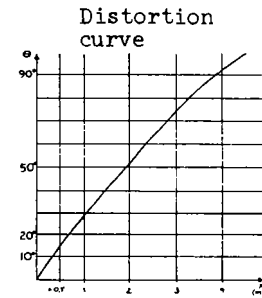

Figure A-1.

Specifications and Distortion Curve for Kinoptik 1.9 mm f/1.9 Super-Tegea Lens

FT RUCKER 105393