

AD-A016911

AD A016911



Special Report 237



EFFECTS OF VARIATION IN DRAWBAR HITCH LOCATION ON VEHICLE PERFORMANCE

Ben Hanamoto

**TECHNICAL
LIBRARY**

September 1975

Prepared for
U.S. ARMY MATERIEL COMMAND
By
CORPS OF ENGINEERS, U.S. ARMY
COLD REGIONS RESEARCH AND ENGINEERING LABORATORY
HANOVER, NEW HAMPSHIRE

The findings in this report are not to be construed as an official Department of the Army position unless so designated by other authorized documents.

REPORT DOCUMENTATION PAGE		READ INSTRUCTIONS BEFORE COMPLETING FORM
1. REPORT NUMBER Special Report 237	2. GOVT ACCESSION NO.	3. RECIPIENT'S CATALOG NUMBER
4. TITLE (and Subtitle) EFFECTS OF VARIATION IN DRAWBAR HITCH LOCATION ON VEHICLE PERFORMANCE		5. TYPE OF REPORT & PERIOD COVERED
		6. PERFORMING ORG. REPORT NUMBER
7. AUTHOR(s) Ben Hanamoto	8. CONTRACT OR GRANT NUMBER(s)	
9. PERFORMING ORGANIZATION NAME AND ADDRESS U.S. Army Cold Regions Research and Engineering Laboratory Hanover, New Hampshire 03755		10. PROGRAM ELEMENT, PROJECT, TASK AREA & WORK UNIT NUMBERS DA Project 1G662601AH91
11. CONTROLLING OFFICE NAME AND ADDRESS U.S. Army Materiel Command		12. REPORT DATE September 1975
		13. NUMBER OF PAGES 19
14. MONITORING AGENCY NAME & ADDRESS (if different from Controlling Office)		15. SECURITY CLASS. (of this report) Unclassified
		15a. DECLASSIFICATION/DOWNGRADING SCHEDULE
16. DISTRIBUTION STATEMENT (of this Report) Approved for public release; distribution unlimited.		
17. DISTRIBUTION STATEMENT (of the abstract entered in Block 20, if different from Report)		
18. SUPPLEMENTARY NOTES		
19. KEY WORDS (Continue on reverse side if necessary and identify by block number)		
Ground vehicles	Operation	Trafficability
Interactions	Terrain	Vehicles
Interfaces	Test equipment	
Mobility	Tracked vehicles	
20. ABSTRACT (Continue on reverse side if necessary and identify by block number)		
<p>The drawbar hitch point location has a direct effect on the trim attitude of a vehicle and also influences the net pull developed by a vehicle during a drawbar pull test. These results have indicated an area of study needing expansion: the relationship of sinkage and slip. Slip-sinkage is a factor which cannot be neglected in the analytical evaluation of vehicle performance. The equations relating sinkage, resistance, trim angle and the traction require further development. One procedural modification that could be made when a drawbar pull test was being conducted to obtain validation data would be to locate the tow hitch point at ground level, eliminating the trim attitude caused by the rearward shift of the center of pressure beneath the contact area.</p>		

PREFACE

This report was prepared by Ben Hanamoto, Mechanical Engineer, of the Applied Research Branch, Experimental Engineering Division, U.S. Army Cold Regions Research and Engineering Laboratory.

The work was conducted under DA Project 1G662601AH91, *Cold Regions Terrestrial Applied Research in Support of Mobility, Work Unit Trafficability of Surfaces*. It was performed as one of the subtasks under the U.S. Army Materiel Command's Mobility Research Program.

This report was technically reviewed by Dr. R.A. Liston and Dr. W.L. Harrison.

Support for the project was provided by personnel of USA CRREL, U.S. Army Tank-Automotive Command and the Keweenaw Field Station, Houghton, Michigan, operated by the Michigan Technological University. Special thanks are extended to M. Jefsen of USA TACOM, J. Stephan, formerly of USA CRREL, and Dr. R.A. Liston, J. Butula, C. Dimmer and A. Hauswirth of KFS.

The contents of this report are not to be used for advertising, publication, or promotional purposes. Citation of trade names does not constitute an official endorsement or approval of the use of such commercial products.

CONTENTS

	Page
Abstract	i
Preface	ii
Introduction.....	1
Procedure.....	2
Results	7
Discussion	12
Conclusions	15
Literature cited	16

ILLUSTRATIONS

Figure

1. Test vehicle: M29C Weasel	3
2. Vehicles and test set-up.....	3
3. Variable hitch point tow bar	4
4. Drive sprocket tachometer-generator and chassis to suspension sinkage measuring pots	4
5. Drum and wire line system for measuring test vehicle speed.....	5
6. Chassis to ground sinkage measuring pots	5
7. Variable hitch point motion resistance push bar	6
8. Soil processing	7
9. Drawbar pull vs slip	8
10. Efficiency vs slip	8
11. Vehicle dimensions	9
12. Track trim vs slip	10
13. Sinkage vs slip, front	10
14. Sinkage vs slip, rear	11

TABLE

Table

1. Calculated values of L at various trim angles for M29C Weasel at 16% slip in stamp sand	15
--	----

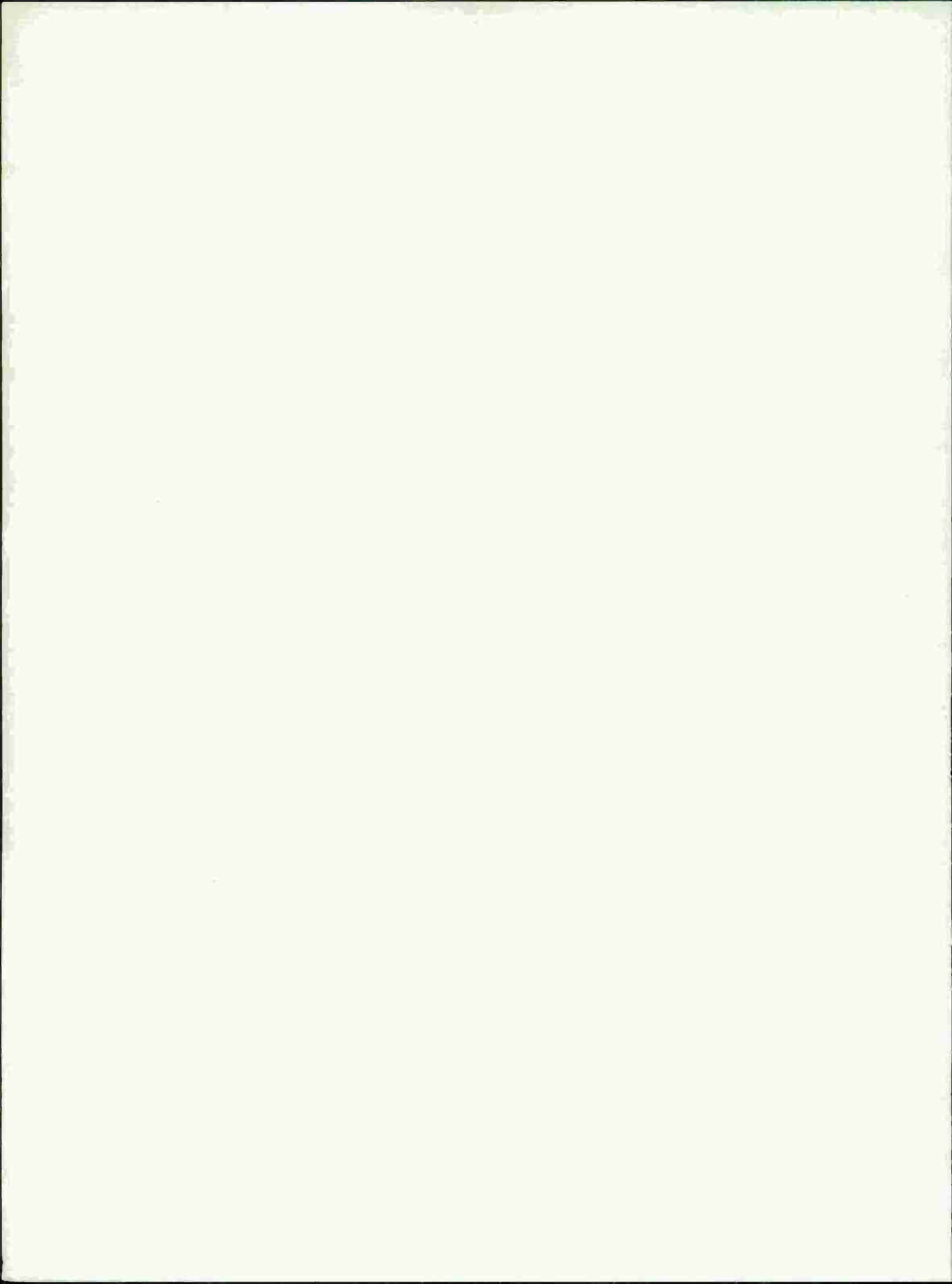

EFFECTS OF VARIATION IN DRAWBAR HITCH LOCATION ON VEHICLE PERFORMANCE

by

Ben Hanamoto

INTRODUCTION

The operating characteristics of a vehicle differ depending on the mode of operation. Two modes exist: the self-propelled condition and the condition of pulling a load. One feature that differs with mode is the vehicle's trim angle, which is significantly affected by whether the vehicle is merely propelling itself or has a drawbar load. Since the trim angle of the contact area and the accompanying sinkage are the topics of interest, the discussion is limited to off-road operation and further limited to operation in snow and deformable soil.

The trim angle of the contact area has been considered in analytical studies of vehicle performance such as predicting sinkage of a track-laying vehicle⁴ and slip-sinkage and traction developed under a track,^{5 6 8} and in results of tracked vehicle tests reported by Stephan.¹¹ A linear pressure distribution was assumed with zero pressure in the front and maximum pressure in the rear in the earlier studies for predicting track behavior. The maximum static sinkage in the rear was then used to determine the motion resistance. Any change in net traction was due to differences in resistance, with gross traction unaffected by the trim attitude. Liston and Reece have studied the effect of the shearing behavior of soils under grousers and tracks and its relation to shear deformation or slip-sinkage. The slip-sinkage phenomenon causes the traction-producing element to take a trimmed attitude and Reece has attempted to relate the trim angle to the horizontal force produced. This relatively underdeveloped area of study in the vehicle-terrain interaction field, slip-sinkage and vehicle trim-traction, may be one of considerable importance because of its effect on overall vehicle performance. Frictional soils may be especially sensitive to the effects of slip-sinkage and trim-traction.

An area of study requiring attention if these effects on performance are not to be neglected is the analysis and interpretation of measured results from drawbar pull-slip vehicle performance tests. By the nature of the test, a load is applied to the drawbar hitch point, forcing the traction-producing element to assume a tail-down attitude. In the analysis of the results, if comparisons were to be made with predicted results using the equations where trim-traction effects are not included, the horizontal force measured might not be what is actually available from the strength of the soil, and incorrect conclusions could result. Another effect of slip-sinkage is that this sinkage is in addition to the static sinkage of a loaded contact area and will influence the motion resistance term. All indications point to an overestimation of performance, with too high a traction value and too low a resistance value.

Tests conducted in frictional materials such as snow and sand^{2 3 11} have shown the dependence of sinkage on slip, of trim angle on slip, and of drawbar pull on trim angle. These results were from

a combined drawbar pull/slip/sinkage test conducted in snow and sand. The same results were obtained from tests conducted in snow, where the drawbar hitch point was varied to assess its effect on drawbar pull performance. These results are:

<u>Drawbar location</u>	<u>Track trim angle</u>	<u>Drawbar pull, lb</u>
Ground level	2.2°	1675
14 in. above ground level	2.3°	1500
26 in. above ground level	4.2°	1425
38 in. above ground level	5.7°	1200

It was decided that to further investigate the trim-traction relationship, other test media should also be used. A convenient site and suitable soil were found near the Keweenaw Field Station, Houghton, Michigan, which is operated for the U.S. Army Tank-Automotive Command by the Michigan Technological University. The test medium was stamp sand, the frictional remains of a copper ore processing operation. Vast areas of stamp sand are deposited along the Lake Superior shoreline near the village of Gay, 15 miles from the field station. More than ten adjacent straight line test lanes over ½ mile long can be accommodated in one particular area. Other desirable features of the test area are: level, obstacle-free surface, homogeneity of the material, easy access by road for the test support equipment and the proximity of the field station.

During the summer of 1974, drawbar pull hitch point tests were conducted in this area. The objective of the tests was to investigate the effect of hitch location on drawbar pull and track contact trim angle of a track-laying vehicle. The description of the tests, procedures, results and discussion comprises this report.

PROCEDURE

The same test set-up used for the earlier drawbar hitch point tests in deep snow^{1 1} was used for the summer stamp sand tests. The test vehicle was an M29C Weasel (Fig. 1), a low ground pressure (1.66 psi) track-laying vehicle. The dynamometer vehicle was an M35A2 2½-ton, 6 X 6 truck. All data recording instrumentation was carried on board the Weasel. The vehicle test set-up is shown in Figure 2. The drawbar hitch point was varied by moving it up and down the vertical tow bar fixture attached to the rear of the test vehicle (Fig. 3).

Eight channels of information were recorded during a test. The drawbar pull was sensed by means of a strain gauge load cell mounted in the tow cable between the test and load vehicles. Slip was measured by two tachometer-generators mounted on each drive sprocket (Fig. 4), which measured track speed, and by a drum and wire line system (Fig. 5), where the speed of the line as it unwound off the drum measured actual vehicle speed. The four other bits of information recorded were sinkage potentiometer readings. Previous tests had shown the need for separate measurements of vehicle chassis to ground sinkage as well as vehicle chassis to unsprung suspension element movement to obtain the true track contact sinkage.^{2 3} To determine trim angles, potentiometers were mounted fore and aft on the test vehicle. Chassis to ground sinkage sensors were attached to skis mounted through arms and pivots attached to the chassis on the left side of the test vehicle (Fig. 6). On the right side, sinkage potentiometers were mounted between brackets attached to the chassis and the unsprung suspension roadwheel arms (Fig. 4). The fore and aft positions of the potentiometers on both sides were identical so that the difference in readings gave the desired sinkage, and as the distance between sensors was known, the trim angle of the contact area could be determined.



Figure 1. Test vehicle: M29C Weasel.



Figure 2. Vehicles and test set-up.



Figure 3. Variable hitch point tow bar.



Figure 4. Drive sprocket tachometer-generator and chassis to suspension sinkage measuring pots.



Figure 5. Drum and wire line system for measuring test vehicle speed.

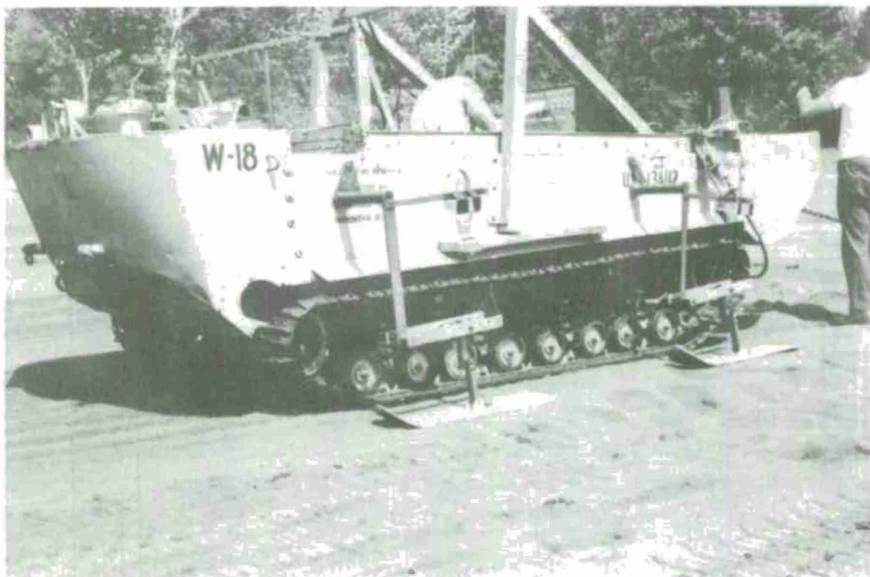

Figure 6. Chassis to ground sinkage measuring pots.

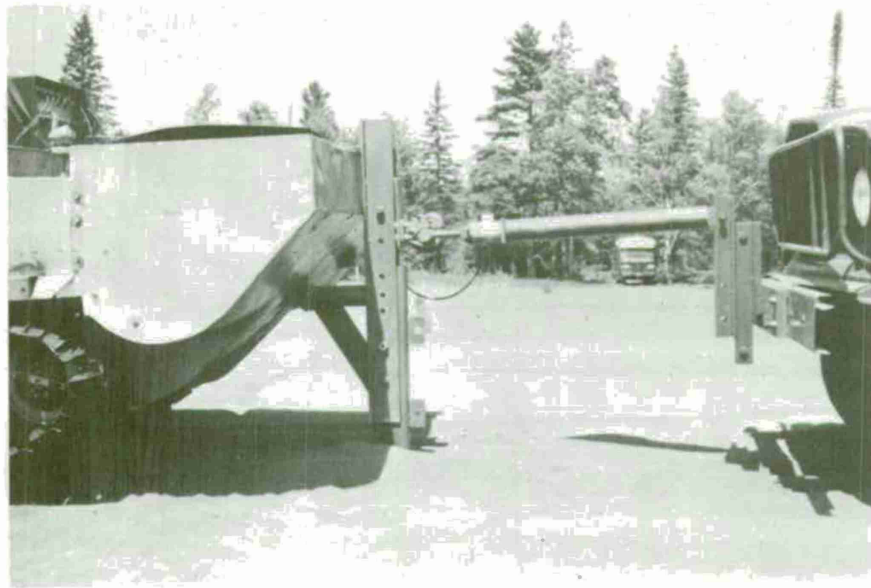

Figure 7. Variable hitch point motion resistance push bar.

The variable hitch point fixture provided four different hitch point locations: ground level, 12 in. below the pintle (14 in. above ground level), at the pintle (26 in. above ground level), and 12 in. above the pintle (38 in. above ground level) (Fig. 3). The motion resistance of the test vehicle was measured by pushing the vehicle at the various hitch points with a solid push bar instrumented with a load cell (Fig. 7).

Test lanes were processed with a disc harrow pulled by the test vehicle (Fig. 8). Three passes with the processor made two test lanes. The test lanes were $\frac{3}{4}$ mile long — long enough for in-line straight ahead testing with no need for turning except once at the end. After the test lanes had been prepared, but prior to testing, the tach-generators and drum speed measuring device were calibrated at comparable test speeds. After the slip calibration check, the test and load vehicles were lined up on the test course and all other instrumentation hook-ups were made. Once lined up, the four sinkage potentiometers were zeroed and the recorder zero point adjusted. With a final check on the load cell calibration, the pre-test procedures were complete.

The test vehicle was operated in low gear and in low transmission range. The drawbar load was gradually increased in increments up to 100% slip. A load-monitoring gauge connected to a hydraulic load cell coupled in the tow cable was mounted beside the driver of the dynamometer vehicle to aid him in maintaining constant loads. Each load increment was held long enough (3 to 4 seconds) to obtain a sustained pull for a constant slip value; a constant pull was assumed to produce constant slip. A complete test could be conducted in 200 to 300 feet of test lane.

The motion resistance push tests were also conducted in the same test lanes. The force required to push the test vehicle, which was in neutral gear, was also recorded. The vehicle's trim attitude was not the same during the push test as it was during the drawbar test.

During the drawbar pull tests with the hitch point at the two higher locations a portion of the hitch fixture was below the soil surface. Resistance tests were conducted to duplicate this condition.



Figure 8. Soil processing.

RESULTS

The results of the tests are presented graphically with the abscissa plotted as percent slip, i.e. $(v_t - v_a/v_t) \times 100$ where v_a equals the actual velocity of the vehicle and v_t the track velocity. Figure 9 shows the drawbar pull as a function of slip for the four hitch locations. The curves, typical of results in frictional material, exhibit a sharp rise in the low slip range up to 30% slip. A leveling or gentle increase in pull occurs from 30% to 80% slip, and then a final sharp rise occurs at the stall or 100% slip condition. Figure 10 shows another way to represent the same data; drawbar efficiency is plotted against slip. Drawbar efficiency is defined as $DBP/W(1 - i_0)$, the drawbar pull to weight ratio less the same ratio multiplied by slip. When there is no forward movement, which occurs at 0 and 100% slip, the efficiency is zero. The peak operating slip range is between 10 and 30%. The average peak efficiency point occurred at 16% slip and the average pull at this slip for the four hitch point locations is given below:

Hitch point	Drawbar pull, lb	Trim angle
Ground level	2750	0°
14 in. above ground level	2700	1.0°
26 in. above ground level	2550	1.0°
38 in. above ground level	2500	1.5°

The difference in pull with the hitch point at ground level and 38 in. above ground level was 250 lb or about 10%, indicating that the hitch point height does influence drawbar pull.

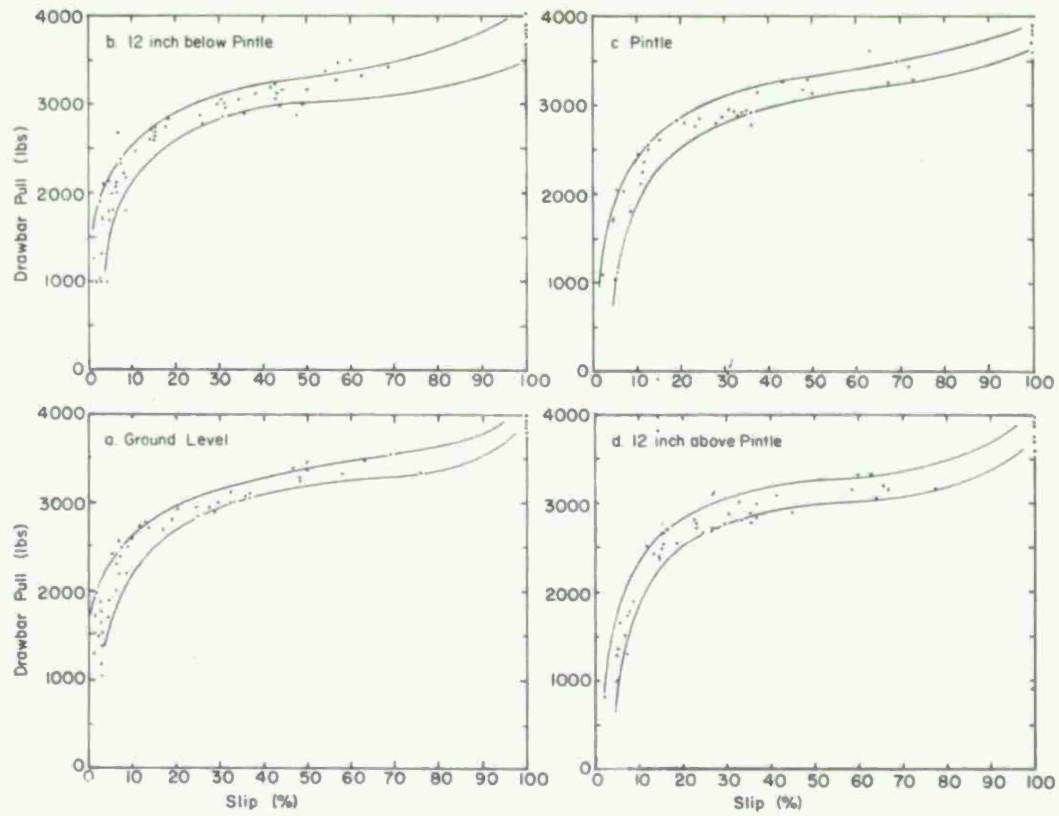

Figure 9. Drawbar pull vs slip.

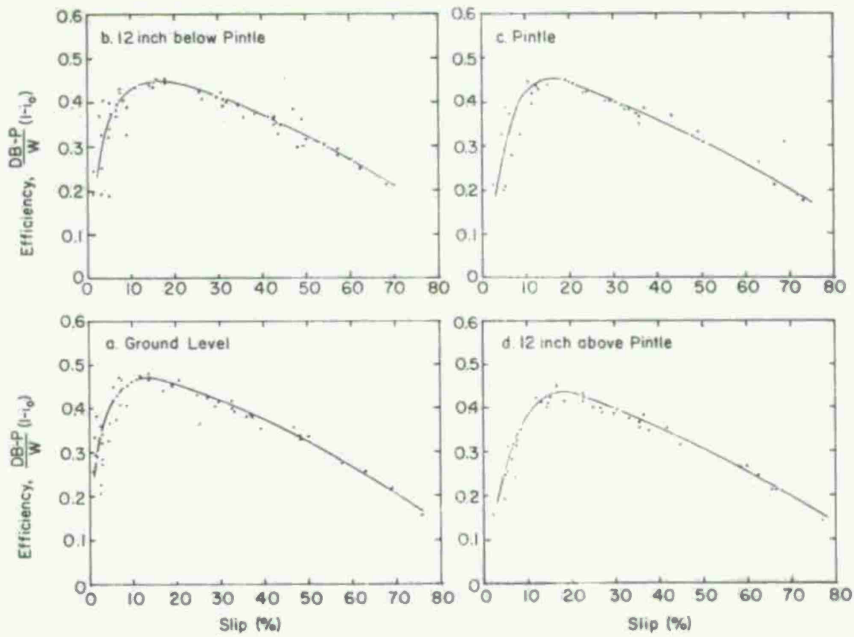

Figure 10. Efficiency vs slip.

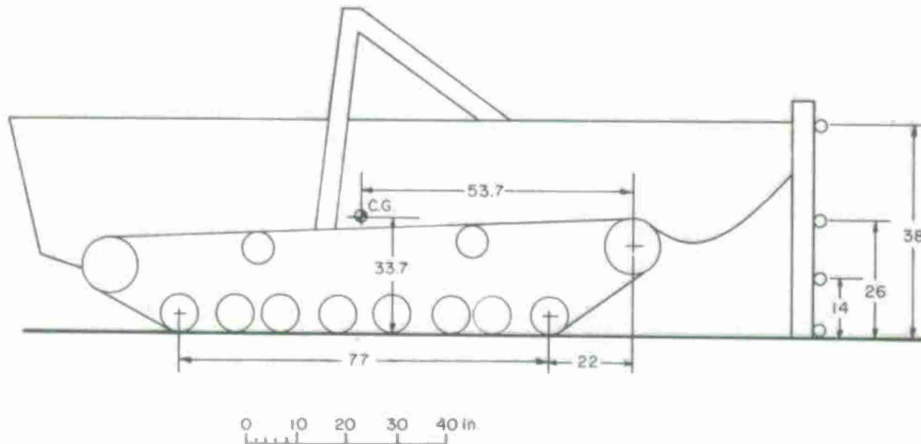

Figure 11. Vehicle dimensions.

The track contact trim angle was another factor affected by variations in the tow hook position. Some basic dimensions for the test vehicle are shown in Figure 11. The shifting of the resultant vertical reaction force is directly related to the trim angle. As an example, with a drawbar pull of 3000 lb the calculated rearward shift from the c.g. location for the four hitch point locations is:

Hitch location	Rearward shift of resultant from c.g.
Ground level	0
14 in. above ground level	8.6 in.
26 in. above ground level	15.9 in.
38 in. above ground level	23.3 in.

The test results of the change in track trim attitude with changing slip are shown in Figure 12. When the hitch point was at ground level where there was no shift in the resultant vertical reaction force, the trim remained unchanged and close to level or slightly nose-down over most of the slip range. At 100% slip a definite tail-up attitude existed with the trim angle nose-down by about 1.5° . The trim angle remained fairly constant at about 1° nose-up when the hitch point was 12 in. below the pintle (14 in. above ground level) with a slight decrease in the nose-up attitude at 100% slip. As the hitch point was placed higher above ground, there was an increase in the trim angle with increase in slip from zero to 50%, most sharply for the highest hitch point location. A decrease in the rate of change in nose-up attitude occurred after 50% slip. The trim angle was lower at 100% slip than at 50% slip for the two higher hitch point locations. This decrease in the trim angle in the high slip range has been noted before, both in deep snow and stamp sand.^{2 3}

Figures 13 and 14 show sinkage of the track as a function of slip. The references chosen were the front and rear track contact points on hard ground. The ground level pull tests showed a constant front and rear sinkage of about 0.8 in. for slips up to 60%. Above 60% slip, the front of the track contact area began assuming a nose-down attitude as the sinkage at the rear of the track decreased to zero while the sinkage at the front increased to 2.4 in. As the hitch point was moved higher above ground level, the rear sinkage steadily increased with slip: from 1.2 to 3.9 in. with the hitch 14 in. above ground, from 1.2 to 4.7 in. with the hitch point 26 in. above ground, and from 0.8 to 5.5 in.

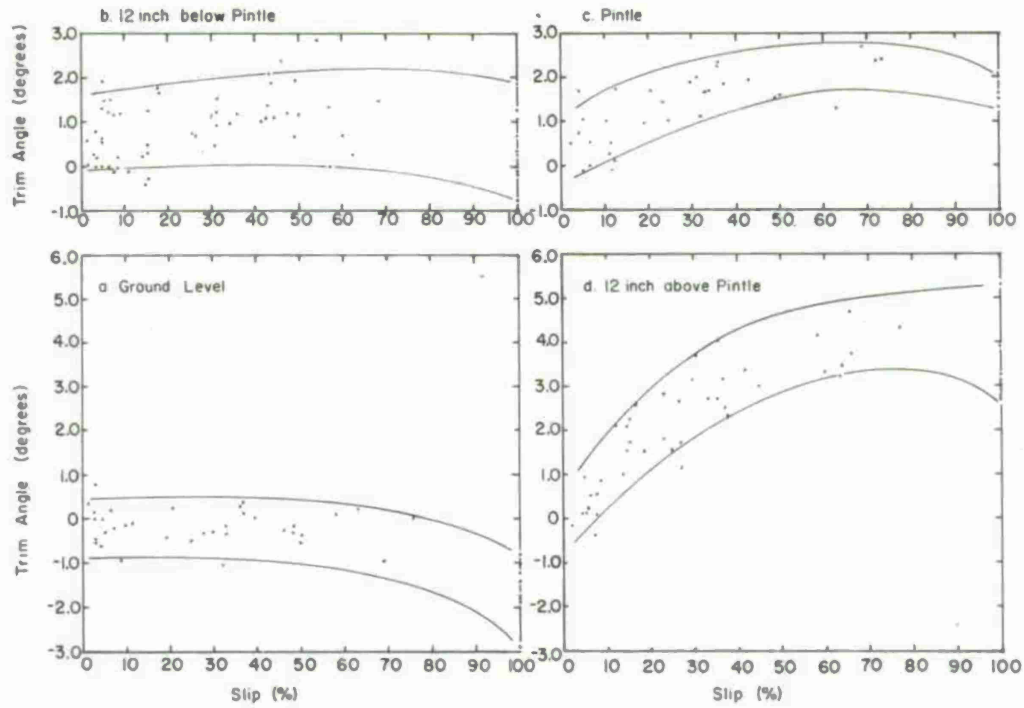

Figure 12. Track trim vs slip.

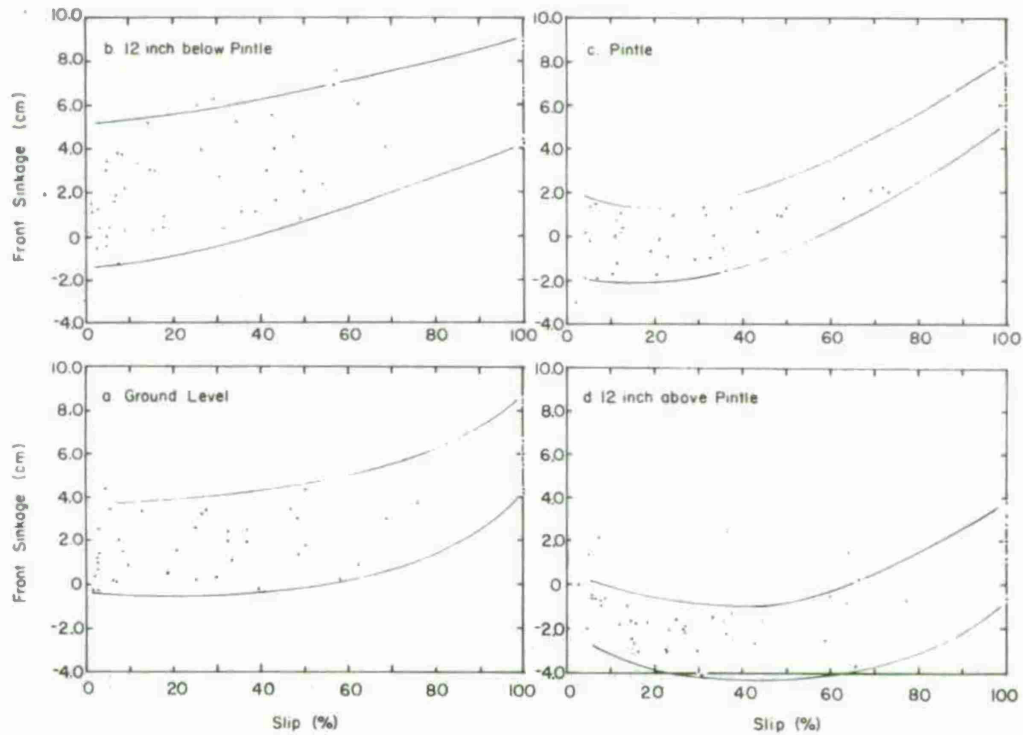

Figure 13. Sinkage vs slip, front.

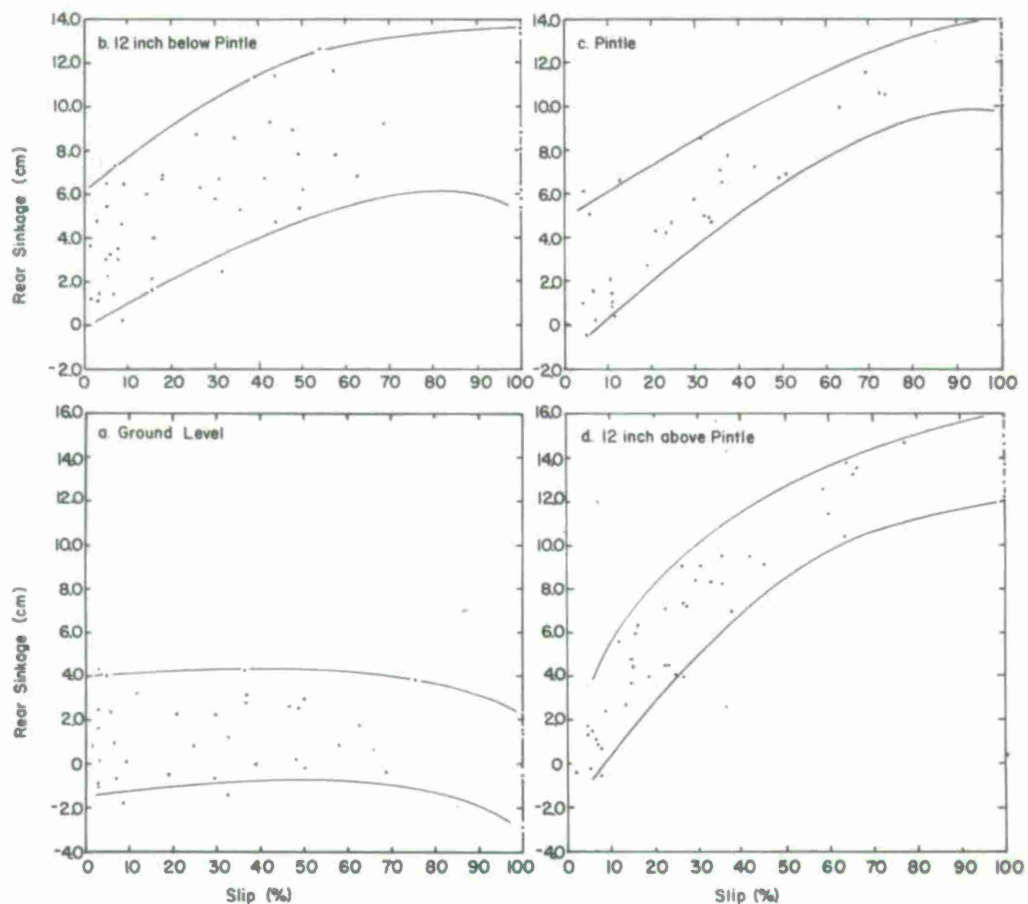

Figure 14. Sinkage vs slip, rear.

with the hitch point at its highest location. One feature to note is that the rate of sinkage increased with increase in the hitch point height. The sinkage at the front exhibited less orderly behavior, especially relative to the height location. With the hitch at 14 in. above ground, the trim attitude increased slightly from zero to 50% slip so that both front and rear sinkages increased, the front increasing from 0.8 to 1.6 in. above 50% slip. The rate of sinkage for the front was greater than for the rear, causing a decrease in the tail-down attitude. When pull was at the pintle or 26 in. above ground, the front sinkage was almost zero for slips up to 50% and increased to 2.4 in. over the slip range 50 to 100%. The unusual behavior of the front sinkage occurred at the highest hitch point location. The front sinkage decreased over the slip range of zero to 50% as the front contact point rose from a point 0.4 in. above ground at low slips to 1.2 in. above ground at 50% slip. Above 50% slip the sinkage increased from 1.2 in. above ground to 0.8 in. below ground level at 100% slip. With the front rising and the rear sinking, the reason for the high rate of trim angle change for the highest hitch location becomes apparent.

During the drawbar pull tests, it was noted that during the two lower hitch point tests the tow hook fixture was above ground level while during the two higher hitch point tests, the bottom end of the fixture was 9.0 in. below ground level. Motion resistance measurements therefore were taken with the tow fixture 9.0 in. in the sand and with the entire fixture above ground. Motion resistance was measured by pushing the test vehicle. The resistance value varied by 45 lb: 457 lb with the fixture above ground and 502 lb with it in the ground. With a measured hard surface rolling resistance of 400 lb, the soil resistance reduces to 57 and 102 lb for the two cases. If the resistance values are low, the effect on net pull may not be significant, but if otherwise, closer analysis will have to be made. One objection to the resistance push test was that the operating conditions of trim and sinkage were not duplicated as in the pull-slip tests. In fact during all of the pull tests, vehicle trim and sinkage changed throughout the slip range so that the soil motion resistance was also changing during the test. Therefore it must be kept in mind that in a drawbar pull-slip test where the sinkage and trim angles do change throughout the slip range, the soil motion resistance is also a varying term. Whenever the resistance term becomes significant this fact will have to be accounted for in the analysis.

DISCUSSION

The primary aim of these tests was to determine the effect of changes in tow hitch location on vehicle performance. In analyzing the results of the tests, it became apparent that there are factors which at present are not being considered in the existing analytical equations for predicting vehicle performance. Depending on the height above ground of the hitch point, trim angles of up to 5° and sinkage much greater than was predicted by existing equations occurred. Therefore track trim and the additional sinkage are two items that will have to be incorporated into the system of equations for predicting vehicle performance.

The sinkage term will be considered first. The total sinkage of the vehicle could comprise at most four separate terms: static, equilibrium, slip and excavation sinkage. Reece and Liston have proposed equations to describe these sinkage terms. The static sinkage equation proposed by Reece⁸ is of the form:

$$p = c k'_c \left(\frac{z}{b}\right)^n + \frac{\gamma b}{2} k'_\phi \left(\frac{z}{b}\right)^n \quad (1)$$

where p = normal pressure or bearing capacity, psi

z = sinkage, in.

b = width of loading area, in.

c = soil cohesion, psi

ϕ = soil internal friction angle, degrees

γ = soil density, lb/ft³

k'_c, k'_ϕ, n = bearing capacity parameters

with

$$k'_c \left(\frac{z}{b}\right)^n = N_{cq}$$

$$k'_\phi \left(\frac{z}{b}\right)^n = N_{\gamma q}$$

N_{cq} and $N_{\gamma q}$ are bearing capacity factors proposed by Meyerhof⁷ in his modification of the Terzaghi bearing capacity theory. He provides values of N_{cq} and $N_{\gamma q}$ for cases of $\phi = 0$ and $c = 0$. For the general case, he provides graphs of N_c , N_q and N_γ and N_{cq} and $N_{\gamma q}$ as functions of N_c , N_q , N_γ , z/b and ϕ .

In the strip load approximation for a track, Liston⁵ has used eq 1 to form the equilibrium equation:

$$p' = \frac{p - c \tan\left(\frac{\pi}{4} + \frac{\phi}{2}\right)}{\left[1 + \tan\phi \tan\left(\frac{\pi}{4} + \frac{\phi}{2}\right)\right]} \quad (2)$$

in which p' is the normal pressure acting on the face of a soil wedge assumed as an appendage to the strip load. He also proposed two other sinkage terms, equilibrium and slip sinkage. Equilibrium sinkage is produced during the development of maximum horizontal shear stress applied to an initially normally loaded area, causing a rotation of the principal plane from the horizontal through an angle θ . This sinkage is encountered during the period in which the shear stress is increasing from zero to its maximum value and the rotation angle is given by:

$$\theta = \tan^{-1}\left(\frac{s}{p}\right) \quad (3)$$

where θ = rotation of principal plane

s = shear stress, psi

p = normal pressure, psi.

At maximum shear stress, $\theta = \pi/4 + \phi/2$. Up to the point of maximum shear, the pressure acting against the face of the soil wedge is given by:

$$p'' = p' \cos^2 \theta \left[1 + \tan\phi \tan\left(\frac{\pi}{4} + \frac{\phi}{2}\right)\right] + c \tan\left(\frac{\pi}{4} + \frac{\phi}{2}\right) \cos^2 \theta. \quad (4)$$

It was found that the rotation of the principal plane resulted in a simultaneous rotation of the plane on which the normal pressure acted, requiring that p'' be introduced. An empirical technique was proposed to relate sinkage and the normal pressure p'' . After maximum shear has been attained, additional sinkage is accounted for under a slip sinkage term defined as:

$$z_j = \lambda j \quad (5)$$

where z_j = slip sinkage, in.

λ = nondimensional soil constant

j = shear deformation, in.

The fourth sinkage term to be mentioned is excavation sinkage. The proposal by Reece⁶ for this sinkage is dependent on slip and the grouser height and is given by:

$$z_x = \frac{hi}{1-i} \quad (6)$$

where z_x = excavation sinkage, in.

h = grouser height, in.

i = track slip.

The consideration of a multi-termed total sinkage is not new. Slip sinkage corrections were attempted by both Bekker¹ and Soltynski,¹⁰ in each case the total sinkage being composed of static sinkage z_s and slip sinkage z_j . A four-termed total sinkage value is new and the important addition is the equilibrium sinkage term. The work of Liston on this topic was primarily laboratory studies using a grousered annulus. Some field work has also been conducted but a relationship and verification of laboratory findings has not been extensively developed. Field tests with a full scale tracked vehicle did produce results to support the laboratory tests and it appears that the equilibrium and slip sinkage terms constitute the major portion of the overall sinkage, especially in frictional soils. Therefore these sinkage terms cannot be neglected and further development of the analytical equation is a much needed area of study.

The track trim angle is the other topic to be discussed. The trim angle was affected by drawbar hitch height and directly related to sinkage. The studies on equilibrium sinkage showed this sinkage to be pressure-sensitive so that effects should be expected, since a rearward shift of the resultant reaction force and a change in the pressure distribution beneath the track occur for any hitch location above ground level. In the low slip range, 0-20%, equilibrium sinkage may be the primary contributor to trim angle for it is in this range that the shear stress builds up to the maximum value. Above 50% slip, where the trim angle decreased some, soil transport rearward or excavation sinkage may be the influencing factor along with the slip sinkage to cause changes in the trim angle. Discussing further the trim angle of the traction-producing interface, besides the effects on sinkage and motion resistance there is the effect on the traction produced or the pull available. Reece⁹ proposed an equation for the horizontal force available from a traction-producing element operating at a trim angle:

$$L = acB \cos \theta + \frac{W - acB \sin \theta}{\cos \theta + B \tan \phi \sin \theta} (B \tan \phi \cos \theta - \sin \theta) \quad (7)$$

where L = horizontal force, lb
 a = contact area, in.²
 b = contact width, in.
 l = contact length, in.
 c = cohesion, psi
 ϕ = internal friction angle, degrees
 θ = trim angle, degrees

and

$$B = 1 + \frac{K}{il} e^{-il/K} - \frac{K}{il}$$

where K = soil horizontal deformation modulus
 i = slip.

Table I presents the calculated values of L at various trim angles for the M29C Weasel operating at 16% slip in stamp sand. The values in Table I show a drastic reduction in force for small changes in trim angle while the measured pull in the table on p. 7 does not show such wide variations. This variance will need clarification which requires further study and refinement of the prediction equation. The horizontal force is the gross traction available from the soil and a motion resistance term must be subtracted to give the net force.

Table I. Calculated values of L at various trim angles for M29C Weasel at 16% slip in stamp sand.

M29C Weasel: wt 5320 lb, $b = 20$ in., $l = 80$ in. Stamp sand: $c = 0.16$ psi, $\phi = 33.6^\circ$, $k = 1.16$ in.

Trim angle, θ°	Horiz. force L , lb
0	3650
0.5	3276
1.0	2972
1.5	2720
2.0	2508

One can see the problem encountered here: motion resistance is a function of sinkage, and it has been shown that sinkage depends on slip; consequently motion resistance must also depend on slip, and this is a study area hardly touched upon yet. The tests and the results reported here were in no way attempts to delineate and expand or develop the proposed analytical equations for predicting the various sinkages and trim and tractive force. The results only emphasize the need and identify the areas in which further investigations are required. Special tests will be required so that more control of the test conditions can be exercised, especially the slip range. Specific tests of traction and sinkage in the 0-20% slip range should be conducted to study the equilibrium sinkage and the traction-trim angle relationships. Two other slip ranges needing study are the 20-60% range, where slip sinkage may be the dominating factor affecting sinkage and traction, and the high range of slip from 60 to 100%, where a combination of slip and excavation sinkage may be the important factors. The control requirement of the test conditions may dictate a laboratory test with a small scale vehicle. A weaker soil than stamp sand with accompanying higher sinkages and trim angles may also be of help in analyzing and clarifying the various causes and effects.

CONCLUSIONS

The location of the hitch point for a drawbar pull-slip test has a direct influence on the trim attitude of the test vehicle. This effect, the rearward shift of the resultant reaction force, in part affects the sinkage. The sinkage is also dependent on track slippage but, depending on the slip range, several sinkage factors in addition to static sinkage contribute to the total vehicle sinkage. From 0 to 20% slip, equilibrium sinkage should be considered; from 20 to 60%, slip sinkage predominates; and from 60 to 100% slip, a combination of slip and excavation sinkage should be considered. The total sinkage then could be a combination of static, equilibrium, slip and excavation sinkage.

In these tests the drawbar hitch location also had an effect on the measured pull. Here the relationship between pull and the trim and sinkage is not clear since these terms are interrelated. Trim angle was dependent on hitch location and on the deformation or slip-dependent sinkages of equilibrium, slip and excavation. The horizontal pull developed was dependent on trim angle. To confound the issue, since sinkage is a function of slip, motion resistance must also be slip-dependent. This interrelationship between the drawbar pull and the influencing factors of sinkages, resistance and trim angle is still an area requiring more detailed investigations.

One modification to the test procedure which will eliminate the shifting of the center of pressure rearward, which affects the trim angle of a test vehicle during a drawbar pull-slip test, is to locate the hitch point at ground level. When the hitch point was located at the traction-producing level, the trim attitude remained constant and level throughout most of the slip range.

LITERATURE CITED

1. Bekker, M.G. (1969) *Introduction to terrain-vehicle systems*. Ann Arbor, Michigan: The University of Michigan Press.
2. Hanamoto, B. (1974) Combined drawbar pull-slip-sinkage measurements. U.S. Army Cold Regions Research and Engineering Laboratory (USA CRREL) Technical Note (unpublished).
3. Hanamoto, B. (1975) Combined drawbar pull-slip-sinkage measurements in deep snow. USA CRREL Technical Note (unpublished).
4. Land Locomotion Laboratory (1966) U.S. Army Tank-Automotive Center, Warren, Michigan, Research Report no. 6.
5. Liston, R.A. (1973a) A strip load approximation for a track. American Society of Agricultural Engineers, Winter Meeting, Chicago, Illinois, Paper no. 73-1507.
6. Liston, R.A. (1973b) The combined normal and tangential loading of soil. Michigan Technological University, Doctoral Dissertation.
7. Meyerhof, G.G. (1951) The ultimate bearing capacity of foundations. *Geotechnique*, vol. 2, p. 301-332.
8. Reece, A.R. (1964) Problems on soil vehicle mechanics. Land Locomotion Laboratory, U.S. Army Tank-Automotive Center, Warren, Michigan, Report no. 97.
9. Reece, A.R. and J. Adams (1962) An aspect of tracklayer performance. American Society of Agricultural Engineers, Winter Meeting, Chicago, Illinois, Paper no. 62-623.
10. Soltynski, A. (1965) Slip sinkage as one of the performance factors of a model pneumatic-tyred vehicle. *Journal of Terramechanics*, vol. 2, no. 3.
11. Stephan, J.A. (1974) The relationship between drawbar pull and acceleration (Field test, winter 1974 at Houghton, Michigan). USA CRREL Technical Note (unpublished).

