

**Best Available
Copy
for all Pictures**

AD-A017 878

AN INSTRUMENT FOR THE MEASUREMENT OF SPECTRAL ATTENUATION
COEFFICIENT AND NARROW ANGLE VOLUME SCATTERING FUNCTION
OF OCEAN WATERS

R. W. Austin, et al

Scripps Institution of Oceanography

Prepared for:

Naval Supply Center
Defense Advanced Research Projects Agency

September 1975

DISTRIBUTED BY:

NTIS

National Technical Information Service
U. S. DEPARTMENT OF COMMERCE



ADA 017878

An Instrument For The Measurement Of Spectral Attenuation Coefficient And Narrow Angle Volume Scattering Function Of Ocean Waters

R.W. Austin
T.J. Petzold

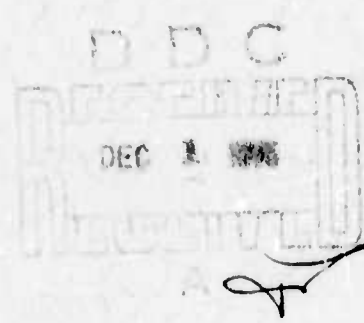

Approved for public release; distribution unlimited.

Final Report
September 1975

Sponsored By
Defense Advanced Research Projects Agency
ARPA Order Numbers 2341 and 2341-1

Contract No. N66857-73-C-0146

UNIVERSITY
OF
CALIFORNIA
SAN DIEGO

SCRIPPS
INSTITUTION
OF
OCEANOGRAPHY

VISIBILITY LABORATORY San Diego, California 92152

Reproduced by
NATIONAL TECHNICAL
INFORMATION SERVICE
U.S. Department of Commerce
Springfield VA 22151

UNCLASSIFIED

SECURITY CLASSIFICATION OF THIS PAGE (When Data Entered)

REPORT DOCUMENTATION PAGE		READ INSTRUCTIONS BEFORE COMPLETING FORM
1. REPORT NUMBER SIC Ref. 75-25	2. GOVT ACCESSION NO.	3. RECIPIENT'S CATALOG NUMBER
4. TITLE (and Subtitle) AN INSTRUMENT FOR THE MEASUREMENT OF SPECTRAL ATTENUATION COEFFICIENT AND NARROW ANGLE VOLUME SCATTERING FUNCTION OF OCEAN WATERS		5. TYPE OF REPORT & PERIOD COVERED Final Report March 1973 - June 1975
		6. PERFORMING ORG. REPORT NUMBER
7. AUTHOR(s) R. W. Austin and T. J. Petzold		8. CONTRACT OR GRANT NUMBER(s) N66857-73-C-0146
9. PERFORMING ORGANIZATION NAME AND ADDRESS University of California, San Diego Visibility Laboratory La Jolla, California 92093		10. PROGRAM ELEMENT, PROJECT, TASK AREA & WORK UNIT NUMBERS ARPA Order No. 2431 & 2431-1 Program Code No. 3M10 & 4M10
11. CONTROLLING OFFICE NAME AND ADDRESS Advanced Research Projects Agency 1400 Wilson Boulevard Arlington, Virginia 22209		12. REPORT DATE September 1975
		13. NUMBER OF PAGES 13
14. MONITORING AGENCY NAME & ADDRESS (if different from Controlling Office) Naval Supply Center Code 87, Bldg. 443-E Oakland, California 94625		15. SECURITY CLASS. (of this report) UNCLASSIFIED
		15a. DECLASSIFICATION/DOWNGRADING SCHEDULE
16. DISTRIBUTION STATEMENT (of this Report) Approved for public release; distribution unlimited		
17. DISTRIBUTION STATEMENT (of the abstract entered in Block 20 if different from Report)		
18. SUPPLEMENTARY NOTES Presented at the "Ocean Optics Seminar" of the Society of Photo-Optical Instrumentation Engineers annual technical symposium, 19 August 1975.		
19. KEY WORDS (Continue on reverse side if necessary and identify by block number) Optical Oceanography Transmissometer Scattering Meter Alphameter, C-Meter		
20. ABSTRACT (Continue on reverse side if necessary and identify by block number) A new instrument has been developed for the study of those optical properties of ocean water that affect the transmission of image-forming light. The instrument performs simultaneous measurements of the volume attenuation coefficient and the volume scattering function at three angles. Any of ten wavelengths covering the spectral range from 400 to 670 nanometers may be used. A depth capability of 500 meters permits the examination of water below the euphotic zone and of the bottom waters on the continental shelf. The considerations leading to the design of the instrument, its capabilities and the unique features it incorporates are discussed. Some examples of the data obtained with the instrument are presented.		

DD FORM 1 JAN 73 1473

EDITION OF 1 NOV 65 IS OBSOLETE
S/N 0102-014-6601

UNCLASSIFIED

SECURITY CLASSIFICATION OF THIS PAGE (When Data Entered)

AN INSTRUMENT FOR THE MEASUREMENT OF SPECTRAL ATTENUATION COEFFICIENT AND NARROW ANGLE VOLUME SCATTERING FUNCTION OF OCEAN WATERS*

R. W. Austin and T. J. Petzold
University of California, Scripps Institution of Oceanography
Visibility Laboratory
San Diego, California 92152

Abstract

A new instrument has been developed for the study of those optical properties of ocean water that affect the transmission of image-forming light. The instrument performs simultaneous measurements of the volume attenuation coefficient and the volume scattering function at three angles. Any of ten wavelengths covering the spectral range from 400 to 670 nanometers may be used. A depth capability of 500 meters permits the examination of water below the euphotic zone and of the bottom waters on the continental shelf. The considerations leading to the design of the instrument, its capabilities and the unique features it incorporates are discussed. Some examples of the data obtained with the instrument are presented.

Introduction

The study and solution of visibility and image transmission problems requires information regarding the optical properties of ocean water for various geographical areas and water depths. The present state of our knowledge of these properties has been severely restricted by the type and capability of the instrumentation that has been available. Visibility and image transmission through water is affected by the optical processes of absorption and scattering. Therefore, measurements of the medium are required from which the significant factors of the absorption and scattering properties can be derived. Generally, both vary with the wavelength of the radiation involved, with geographical location, with depth, and with time. It is essential, therefore, that the measurements be obtained rapidly over the spectral region of interest and over the volume of water of concern in order that a complete and quasi-instantaneous assessment of these properties can be obtained.

Recent studies of near-surface data from stable, well-documented water confirm that a reasonably precise estimate of the total scattering coefficient, s , can be obtained if the volume scattering function (VSF), $\sigma(\theta)$, is known at a suitably small angle from the direction of propagation. As a result of this, the absorption coefficient, a , may be determined from a knowledge of the volume attenuation coefficient, α , and the VSF $\sigma(\theta)$ since $\alpha = s + a$. Thus a single instrument capable of measuring α and $\sigma(\theta)$ at a number of wavelengths in rapid succession would satisfy the requirement for simultaneous spectral data on the absorption and scattering properties of ocean waters of interest. The validity of the correlation between $\sigma(\theta)$ and s for near-bottom waters, where the scattering material may differ in important respects from that found in surface waters, has not yet been verified. We expect from theoretical considerations and from our evaluation of the nature of the near bottom scattering material that a satisfactory relationship between $\sigma(\theta)$ and s will be found to exist.

On this premise, the Visibility Laboratory has developed an instrument to perform the simultaneous measurement of the beam transmittance, T , (from which α may be obtained) and the VSF at three small angles. This instrument when used in conjunction with the Visibility Laboratory general angle scatter meter** capable of measuring the VSF from 10° to 170° can obtain values of $\sigma(\theta)$ over a range of angles large enough to allow the computation of s directly from the relationship,

$$s = 2\pi \int_0^\pi \sigma(\theta) \sin\theta \, d\theta \quad (1)$$

If the expected correlation between $\sigma(\theta)$ and s is found in bottom water below the euphotic zone, we may proceed with confidence to utilize this single instrument, measuring Alpha and volume SCATTERing function (hence the acronym ALSCAT), for the evaluation of those optical properties of near-bottom water which are important for the assessment of the operation of underwater viewing systems.

Design Objective and Specifications

This section will provide a brief description of the important functional specifications of the instrument. It will also serve as an introduction to the instrument and some of the concepts used in its design. Additional background and details will be provided in later paragraphs.

General Description

The instrument system consists of four components:

1. An underwater unit measuring beam transmittance, volume scattering function, water temperature, and instrument depth.
2. A special cable with strain member (two lengths, 400 foot and 2000 foot, the latter for use on an existing winch).

* The work described was performed with support provided by the Defense Advanced Research Projects Agency under ARPA Order 2431.

** Developed with support provided by the Naval Air Development Center under Contract N62269-71-C-0676.

3. A deck unit for topside digital signal conditioning, data display, and functional control of underwater unit.
4. A data recording unit with a 21-column digital data printer, an incremental magnetic tape data recorder and an x, y_1, y_2 plotter.*

The maximum design operating depth is 500 meters (1640 feet). The cable strength is adequate to support the instrument and 2000 feet of cable in water with normal acceleration forces.

Vertical profiles of transmittance, volume attenuation coefficient, volume scattering function, and water temperature may be obtained at a rate of about 36 meters per minute or 14 minutes for a 500-meter profile (neglecting wire angle effects). Faster payout and retrieval may be possible depending upon the gradients of the variables, the system time constants, and the desired accuracy.

Optical Measurements

All optical measurements may be made at any of 10 wavelengths selectable by command from the surface. The wavelength is determined by interference filters having half power bandwidths of 12.3 nanometers or less and nominal center wavelengths of 400, 430, 460, 490, 520, 550, 580, 610, 640, and 670 nanometers.

The water path length may be changed from 1/2 meter to 2 meters in 1/2-meter increments by means of spacers installed between the projector and receiver.

Collimated projector and receiver optical systems are used. The projector uses a 15-watt tungsten lamp generating a beam 9.33 millimeters in diameter having a divergence of 0.5 milliradians (half angle in water). The lenses in the projector and receiver are plano-convex achromats specially fabricated for this instrument.

A portion of the flux from the lamp is carried directly to the receiver by a fiber optic light pipe. This flux, which is unaffected by the characteristics of the water path, serves as a continual reference signal to enable the system to compensate for fluctuations in the lamp output and/or receiver sensitivity.

The receiver acceptance half angle is 1.5 milliradians in water for the transmittance measurement. The receiver aperture stop for transmittance is 20 millimeters in diameter. The receiver field of view and aperture stop diameter are changed for the three volume scattering function (VSF) measurements. The nominal measurement angles (in water) over which the VSF is measured are 3, 6, and 12 milliradians. For path lengths 1 meter and shorter all three VSF measurements can be made. With a water path length of 1.5 or 2 meters, only the 3 and 6 milliradian measurements can be made due to restrictions created by the 50 millimeter maximum receiver aperture diameter.

Pressure Depth Measurement

Instrument depth is determined by a bonded strain gage pressure transducer having a range of 0-750 psia and a terminal linearity of ± 0.15 percent of full scale output. The transducer will withstand pressures of 150 percent of full scale without affecting performance characteristics and in excess of 250 percent of full scale before bursting.

The transducer output is amplified to obtain a scale factor of 1 volt per 100 meters of instrument depth (i.e., 5 volts for maximum depth of 500 meters). The digital data transmission link has a resolution of 0.01 volts, corresponding to an effective depth resolution of 1 meter. The transducer linearity limits the direct reading accuracy to ± 0.8 meters. An alternate range of 0-200 meters may be selected from the control panel. This selection increases the gain in the underwater instrument by a factor of 10 with a resultant depth resolution of 0.1 meters. As the accuracy in this case is limited by the basic transducer, no improvement in absolute accuracy is realized.

Temperature Measurement

Water temperature at the depth of the instrument is sensed by a precision platinum resistance thermometer. The sensor resistance changes approximately 1.8 ohms per degree Celsius with a repeatability of $\pm 0.03^\circ\text{C}$. The sensor time constant in agitated water is 1.6 seconds or less.

The temperature response of the sensor system is 1 volt per 10°C on the topside temperature display and recording. The range of temperatures which the sensor system can handle exceeds the requirements for ocean measurements. The time constant of the thermometer probe requires that the rate of instrument lowering or retrieval be reduced for those portions of the water column where there is a marked thermocline if the full temperature accuracy is to be achieved.

Digital Data and Command Transmission System (DIDACTS)

This system provides for the transmission of digital addresses and commands from the surface control unit to the various underwater sensors (downlink) and for the transmission of digital data from the underwater sensors to the surface for display and recording (uplink).

The underwater portion of DIDACTS will handle up to eight analog input channels (± 10 volts full scale). As any of these channels is addressed by the surface unit, its analog voltage is multiplexed into a bi-polar analog-to-digital converter. The digital data along with the status and address of the channel are sent to the surface via the twisted pair data transmission line in the underwater cable. Upon receipt of the digital information, the surface unit stores and displays the data and status information. It then initiates

- * The data logger was constructed with funds provided by another contract, but it is compatible with the recording requirements of ALSCAT and it will be used with this instrument.

the cycle for another channel by sending down to the underwater unit the appropriate address and any digital command for a change in status of the underwater unit. The time required to complete the interrogation of a channel is 7.83 milliseconds. As seven channels are currently being used, each channel is sampled 18.24 times per second. This data rate is in excess of that required to accurately record any of the variables.

The capability is provided to address any one or any combination of the eight data channels in sequence. Only those so addressed will be interrogated.

A 4-bit command word is associated with each channel. These digital commands are transmitted to the underwater unit with each cycle of the DIDACTS where they are placed in a storage register. If the status of the D/W controlled function (e.g., wavelength filter wheel position, photomultiplier tube high voltage setting, chopper motor speed setting, or scale factor for depth measurement) is not in agreement with the command, a digital comparator senses this and initiates a sequence of changes until the status agrees with the command. The digital condition of the status generator associated with each controlled function is placed in the underwater shift register and sent to the surface where it may be displayed and recorded along with the data. If the command and status signals in the surface unit do not correspond, display and recording of data is inhibited.

Optical Design

Design Considerations

In order to obtain the smallest error in an instrument designed to measure the volume attenuation coefficient, a , it can be shown that the path lengths through the medium should be around $1/a$ or one attenuation length. Thus in very clear oceanic water where a may be as large as $a = 0.05 \text{ m}^{-1}$ a water path length of 20 meters is indicated. Such path lengths are usually impractical in field instruments without resorting to some system for multiple folding of the optical path. The multiplicity of optical surfaces which results, with the attendant requirement for knowing the exact reflectance or transmittance of each surface, quickly negates any gain resulting from the increased path length. Furthermore, the optimum length changes with wavelength and water mass, and the advantage of the long path rapidly decreases as the attenuation length decreases. As an example, given an instrument having a path length of 20 meters and another with a path length of 2 meters - both having the same photometric accuracy - the "crossover attenuation coefficient," a_c , i.e., the coefficient where the errors in the measurement of a is the same for the two instruments, would be $a_c = 0.128 \text{ m}^{-1}$. For a 2-meter instrument with a photometric error 0.2 percent, the error in the determination of $a = 0.05 \text{ m}^{-1}$ due to this photometric error would be $\Delta a = 0.001 \text{ m}^{-1}$, and the relative error would be $\Delta a/a = 0.022$ or 2.2 percent. This should be acceptable for all but the most critical research purposes. The same instrument shortened to 1 meter and used in the same water would yield $\Delta a = 0.0021 \text{ m}^{-1}$ and $\Delta a/a = 0.042$ or 4.2 percent - an error that would still be acceptable for most applications. Thus a 1 or 2-meter transmissometer with good photometric accuracy can provide satisfactory volume attenuation coefficient data for clear ocean waters. These shorter instruments are greatly to be preferred from the standpoint of ease of handling at sea to the longer instruments or to those having a large number of reflecting or transmitting surfaces having critical cleaning requirements as in some instrument designs with multiply-folded optical paths.

There was an additional and over-riding consideration forcing the design to shorter path lengths. That was the requirement to measure the small angle volume scattering function (VSF) using the same path as used for the beam transmittance measurement. Here the designer wishes to measure the scattering from a thin lamina so that the flux remains essentially constant throughout the measurement volume. The requirement for adequate receiver power places a lower limit on the measurement volume, and the cross-section of this volume, i.e., the beam diameter, finds practical limits in the size of the receiver optics. Optical requirements for the size of the transmissometer beam place further restrictions on the beam diameter.

The compromises then were (a) between long measurement path lengths for accuracy in clear water transmittance (hence a) measurements and short water path lengths for small-angle VSF measurements and for ease of handling at sea, and (b) between a large diameter beam for precision in measurement of VSF and small diameter to keep the size of the receiver optical system reasonable.

In this instrument the projector and receiver beams were collimated as opposed to the cylindrically limited design used in previous Visibility Laboratory instruments. The primary reason for this was to allow the precise specification of angular fields of view in both the VSF and the transmittance measurements. A corollary benefit is that the measurement path length may be changed without affecting the instrument calibration providing only that the receiver entrance aperture is of adequate diameter to accept all flux scattered at the maximum measured scattering angle for the longest measurement path.

Description of the Optical Design

The optical system consists of a projector which provides a small beam of highly collimated light and a collimated receiver whose optical axis is aligned with the axis of the projector. The field-of-view of the receiver is caused to change repetitively, by means of an indexing field stop wheel located at the focal point of the receiver objective lens. For the measurement of transmittance, the field-of-view is determined by the requirement to pass all flux leaving the projector which has been neither absorbed nor scattered. Thus if the power in the beam as it leaves the projector is P_0 and that remaining after traversing an instrument water path length ℓ is P_ℓ , then $T = P_\ell/P_0 = e^{-a\ell}$.

For the measurement of the volume scattering function at angles close to the forward direction, the field-of-view of the receiver is such that it blocks the directly transmitted light and accepts flux which has been scattered by the water at a small range of angles around the desired median angle. Those portions of the optical system that are illuminated by the projector beam can also contribute to scattered flux which is indistinguishable from that scattered by the water. To reduce this unwanted signal to a minimum, the design emphasized reducing the number of optical surfaces and amount of glass to a minimum and specifying the highest quality materials and surfaces in the optics used.

The volume scattering function, $\sigma(\theta)$, at angle θ from the direction of propagation may be determined from the expression:

$$\sigma(\theta) = \frac{1}{\omega_{\theta} \ell} \cdot \frac{P_f(\theta)}{P_f(0)} \quad (2)$$

where $P_f(0)$ = the on-axis power leaving the measurement volume,
 $P_f(\theta)$ = the received power scattered at a mean angle, θ , into a solid angle ω_{θ} ,
 ω_{θ} = the solid angle of acceptance of the receiver about the measurement angle θ ,
and ℓ = the path length through the measurement volume.

This relationship may be derived as follows: The volume scattering function is defined by the differential relationship.

$$dJ(\theta) = \sigma(\theta) \cdot H \cdot dV \quad (3)$$

where $dJ(\theta)$ is the radiant intensity scattered in the direction θ by an elemental volume, dV , of the scattering medium. H is the irradiance incident on the elemental sample volume. In an instrumental determination of $\sigma(\theta)$, a sample volume of finite size is, of course, required in order to obtain measurable quantities of power. The size of the volume and of the receiver solid angle of acceptance, ω_{θ} , are determined by the sensitivity of the receiver, the power in the projector beam, the spectral bandwidth, and the range of $\sigma(\theta)$ values to be measured. In ALSCAF the sample path length is sufficient so that losses along the path cannot be neglected in the derivation. The measurement path is shown schematically in Figure 1.

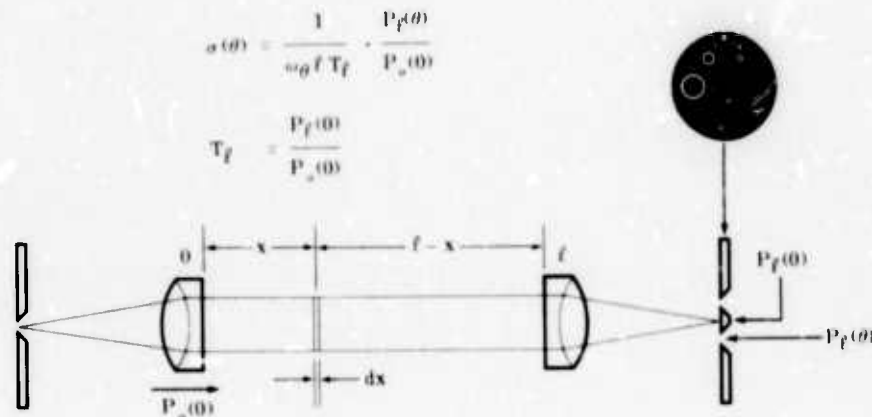

Fig. 1

Let $P_o(0)$ = the power in the beam emitted by the projector into the water,
 A_p = the area of the projector beam,
 ℓ = the length of the measurement volume,
 T_x = the transmittance of the water path to x
and T_{ℓ} = $P_f(0)/P_o(0)$ = the transmittance of the total water path.

Then, since power in the beam at x is given by

$$H_x A_x = P_x = P_o(0) \cdot T_x$$

and

$$dP_s(\theta) = \omega_{\theta} dJ_s(\theta),$$

represents the power scattered in direction θ by the element of path dx at x , Eq. (3) may be rewritten as

$$dP_s(\theta) = \sigma(\theta) \cdot T_x \cdot P_o(0) \omega_{\theta} dx. \quad (3a)$$

Now the amount of this power reaching the receiver at l will be

$$dP_{\ell_s}(\theta) = \sigma(\theta) T_s \cdot T_{\ell_s} \cdot P_o(0) \omega_{\theta} dx \quad (4)$$

and since $T_s \cdot T_{\ell_s} = T_{\ell}$, Eq. (4) becomes

$$dP_{\ell_s}(\theta) = \sigma(\theta) T_{\ell} P_o(0) \omega_{\theta} dx \quad (4a)$$

Solving for the total scattered power received from the entire measurement volume, we obtain

$$P_{\ell}(\theta) = \sigma(\theta) T_{\ell} P_o(0) \omega_{\theta} l \quad (5)$$

from which we obtain

$$\sigma(\theta) = \frac{1}{\omega_{\theta} l T_{\ell}} \cdot \frac{P_{\ell}(\theta)}{P_o(0)} \quad (6)$$

or since $P_{\ell}(0) = T_{\ell} \cdot P_o(0)$

$$\sigma(\theta) = \frac{1}{\omega_{\theta} l} \cdot \frac{P_{\ell}(\theta)}{P_{\ell}(0)} \quad (7)$$

The above derivation assumes single scattering and that the path travelled by a scattered photon is not significantly longer, in terms of attenuation losses, than that travelled by an unscattered photon.

Projector. The projector source is a 15-watt, 6-volt projection lamp with a 1.5 x 1.9 mm "flat core" filament (Osram 8018). The lamp illuminates a field stop 0.44 millimeters in diameter placed at the focal distance from the projector objective lens (see Fig. 2). This lens is a 330-millimeter focal length 30 millimeter diameter plano-convex achromat with the plane surface in contact with the water. A condensing lens images the filament in the projector aperture stop. The projector clear aperture is 9.33 millimeters in diameter; however, since the diagonal of the filament image at this plane is slightly smaller than the aperture diameter, the projector beam as it enters the water is rectangular. The projector beam divergence is 0.67 milliradians in air and 0.5 milliradians in water.

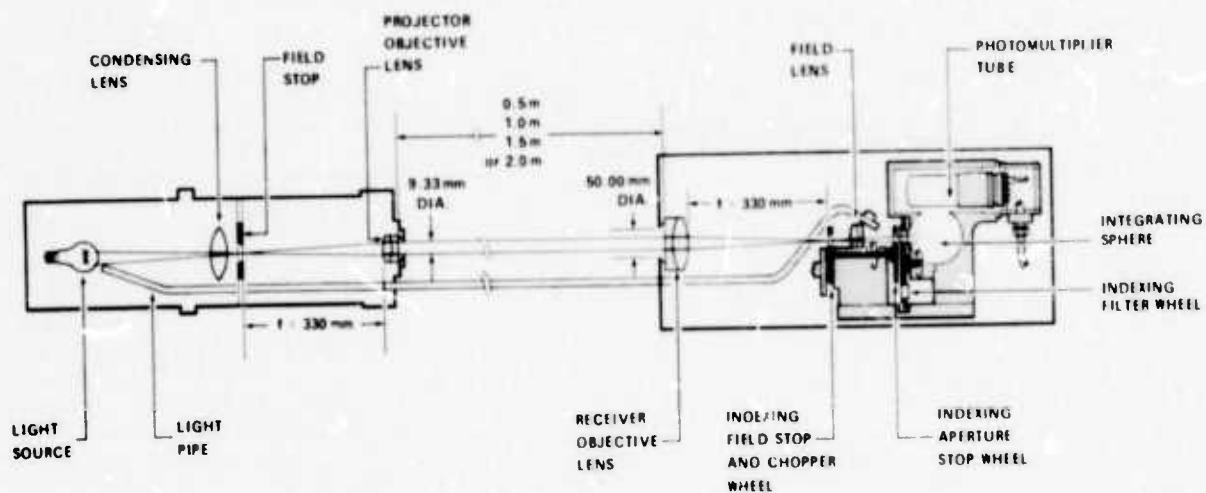

OPTICAL SCHEMATIC - ALSCAT
(Not Drawn to Scale)

Fig. 2

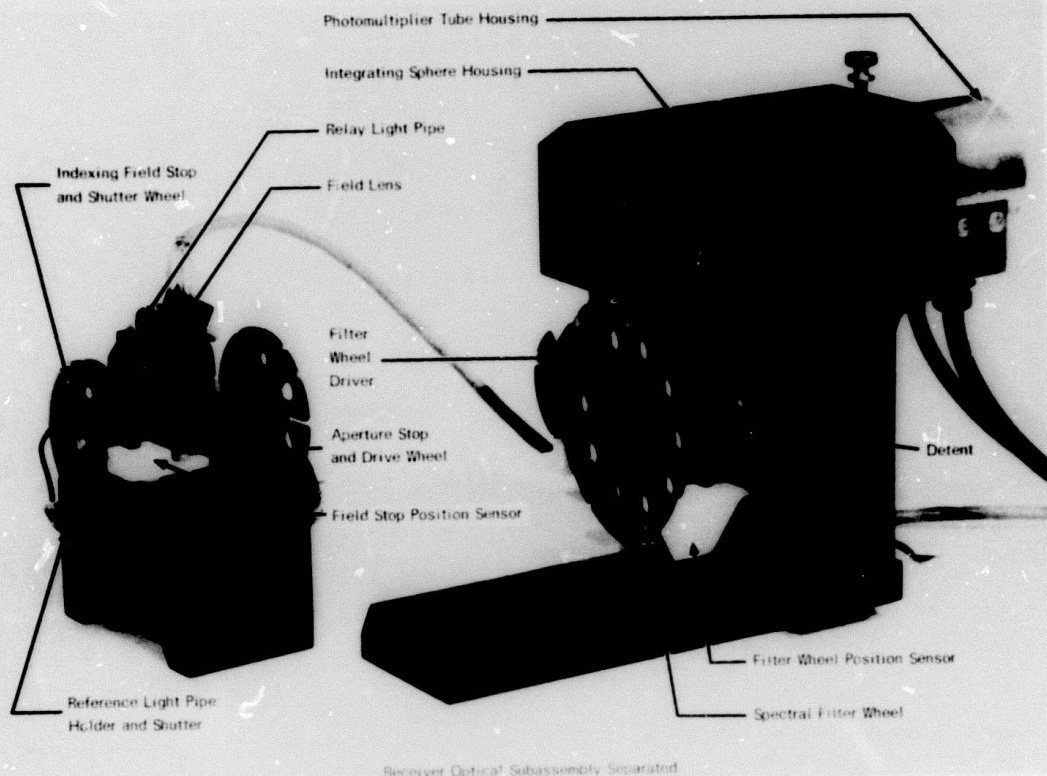

Fig. 3

Receiver. The receiver also has a plano-convex achromatic lens of similar design but having an overall diameter of 75 millimeters. A disk containing four field stops is located in the focal plane of the lens. This disk rotates about a shaft through its center and is caused to index to six precisely determined positions by a mechanical intermittent drive (see Figs. 2 and 3). The four field stops are thus caused to stop, in sequence, at the required location on the receiver optical axis, while each of the four optical measurements are performed, i.e., transmittance, and the volume scattering function at each of three angles. As the field stop wheel assumes the remaining two of its six positions, the receiver, (a) samples light flux carried from the lamp by a fiber optic light pipe for systems gain adjustment and then, (b) is shuttered to place it in the dark for systems zero-set.

The four receiver field stops consist of: (1) a clear stop 1.3 millimeters in diameter which provides a 1.5 milliradian (half angle) field-of-view for the transmittance measurement, and (2) three clear annular stops which provide for volume scattering function measurements at the nominal angles of 3, 6, and 12 milliradians, as shown in the table below. When these annular field stops are in place, the image of the projector field stop falls on the opaque central spot of the stop preventing direct flux from the projector from reaching the receiver. In this situation only that flux from the projector which has been scattered by angles within the limits θ_{min} and θ_{max} (shown in the table) can be measured.

	Nominal Angle (mrad)	θ_{min} (mrad)	θ_{max} (mrad)	θ_{mean} (mrad)	ω (sr)
θ_1	3	1.76	4.43	3.09	5.18×10^{-5}
θ_2	6	4.57	7.63	6.10	11.72×10^{-5}
θ_3	12	10.46	13.94	12.20	26.72×10^{-5}
θ_4	1.5		1.49		0.70×10^{-5}

The optimum size of the receiver aperture stop changes for the four measurements. For the transmittance measurement, the aperture needs to be large enough to accept all unscattered rays from the projector in air, for the longest path length. To accommodate for slight mechanical misalignment in the course of field use, a small increase in the receiver aperture diameter has been provided. For the VSF measurements, the size of the receiver aperture must be such that flux scattered by an angle θ_{max} from the perimeter

of the projector beam as it enters the water can be accepted. Thus if the projector aperture stop diameter is ϕ_p and the path length is l , the minimum receiver aperture stop must be

$$\phi_r = \phi_p + 2l\theta_{max}$$

To reduce the errors introduced by the inclusion of scattered light in the transmittance measurement and by the unwanted inclusion of secondary scattered light in the VSF measurement, it is desirable to limit the size of the aperture stop to that required for each measurement. In this instrument the receiver aperture stop is determined by the size of the image of a circular stop in the "indexing aperture stop wheel" formed by the field lens (see Figs. 2 and 3). This image is formed at the water surface of the receiver objective lens. The field stop wheel and the aperture stop wheel are on the same shaft and index together. Thus each of the four optical measurements are performed with an appropriate aperture stop size. A slight compromise was necessary in the interest of keeping the size of receiver lens and its mounting to within what were felt to be reasonable limits. Thus the maximum receiver stop diameter was kept to 50 millimeters which precludes measuring the VSF for $\theta = 12$ milliradians in the 1.5 or 2.0 meter path length configurations.

The stop wheel mechanism indexing speed can be controlled from the surface up to a maximum of 3 complete cycles of the wheel per second (18 indexing actions per second).

Spectral Filtering. A wheel carrying 10 narrow-band interference filters is located between the aperture stop wheel and the entrance port of the integrating sphere (see Figs. 2 and 3). The operator may select the filter required by a command from the surface control unit. The filter characteristics are shown in Fig. 4.

CHARACTERISTICS OF SPECTRAL FILTERS IN ALSACAT

(SECOND SET, DITRIC 3 CAVITY)

NOMINAL WAVELENGTH (nm)	CENTROID λ (nm)	MAXIMUM λ (nm)	HALF BANDWIDTH (nm)	$\int T(\lambda)d\lambda$	T_{equiv}
400	400.7	402	8.4	4.129	0.492
430	430.3	431	7.0	3.402	0.486
460	459.8	459	5.9	2.903	0.492
490	489.5	489	7.4	4.097	0.554
520	520.1	521	6.7	4.600	0.687
550	548.3	549	7.6	4.840	0.637
580	580.0	579	9.4	6.284	0.669
610	608.4	604	11.3	6.827	0.604
640	641.0	638	11.2	6.666	0.595
670	669.3	668	12.3	7.519	0.611

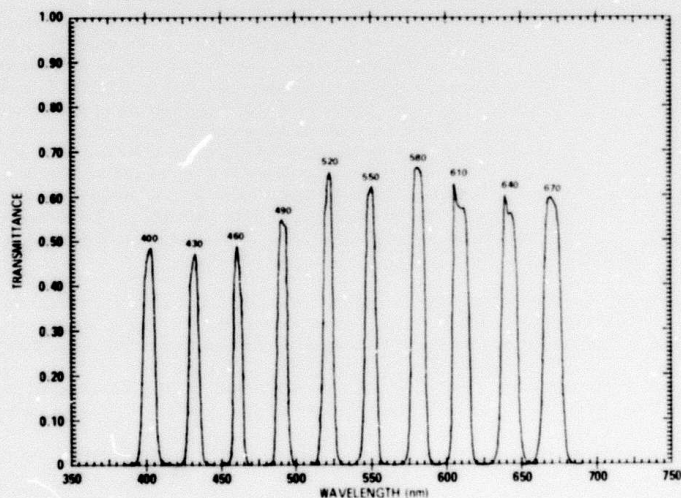

Fig. 4

Photodetector Unit. An integrating sphere has been used to ensure that the same portion of the photocathode of the photomultiplier tube (RCA 1P28AV1) is used for all measurements. This was particularly important since the distribution of flux in the beam exiting the filter wheel changes markedly for the five measurements (including the fiber optic "reference" measurement). Such changes in distribution can cause the output of the photomultiplier tube to be non-proportional to the total flux, if different areas of the photocathode are used.

Underwater Lenses

The amount of glass and the number of surfaces in the optical paths of the instrument was kept to a minimum in the interest of reducing the residual instrumental scattering. To this end plano-convex lenses with their plane side in contact with the water were used in lieu of the usual combination of lenses and plane-parallel optical glass windows. The requirements for strength, low scattering and achromatization dictated lens requirements that could be met only by special lens design and fabrication. Consequently, two-element cemented achromats were designed by one of the authors, (TJP), and manufactured to strict tolerances with respect to surface finish, bubbles, inclusions, strain and striae. The following table lists the major specifications of the lenses:

ALSCAT OBJECTIVE LENSES

Diameter	{ Receiver Projector	75 mm 30 mm
Focal Length (587.56 nm, He d-line)		330 mm \pm 1%
Axial Color Correction: 400 to 670 nm		\pm 0.2% of focal length
Front Surface		Flat
Rear Surface: Radius of Curvature		143.69 mm
All Surfaces: Conformity to Above		Within 1 fringe per 12 mm
Surface Quality per MIL-0-13830		80 - 40
Central 14 mm (Receiver) Central 10 mm (Projector)	}	20 - 10 or better
Maximum Deviation Between Optical and Mechanical Axes		6 minutes
Lens Thickness	{ Receiver Projector	35 mm 10 mm

Mechanical Design

The mechanical design was predicated on providing a rugged, in-line instrument that could take the normal shipboard abuse and maintain its optical alignment. The projector and receiver assemblies are mounted in cylindrical pressure vessels that are accurately positioned with respect to each other by heavy aluminum cylindrical spacers. Figure 5 shows the instrument assembled in its 1-meter configuration at the top, and the sketches at the bottom of the figure show how various combinations of the spacers can be used to vary the water path length from 0.5 to 2.0 meters. The elongated holes in the cylinder walls of the spacers are provided to facilitate rapid exchange of water in the measurement path. The spacers are held together by split clamp rings which allow rapid and accurate changes in path length. All optical references are made to the large face plate to which the receiver pressure housing and the first spacer (B in Fig. 5) are attached. The plate was carefully machined to receive the curved surface of the receiver objective lens, and the plane water-contact surface of this lens is parallel to the plane of the outer surface of the plate. The optical components for the receiver are mounted on an optical bench fastened to the inner surface of this face plate and held rigid by the addition of two large rods and an end plate brace. The projector unit is centered and aligned to the receiver by means of two sets of three adjustment screws in the wall of the spacer tube.

Access to the receiver optics and electronics is obtained by removal of the cylindrical pressure housing. Access to the lamp is obtained by removing first the protective guard (unit E in Fig. 5), and second, the rear half of the projector pressure housing. The optical alignment is not affected by this procedure. Lamp replacement or adjustment are quick and simply effected.

The fiber optic light pipe and wires from the receiver to the projector are carried through aluminum tubing attached to the respective face plates by conventional tubing compression fittings. A separate tubing length is required for each of the four measurement path lengths.

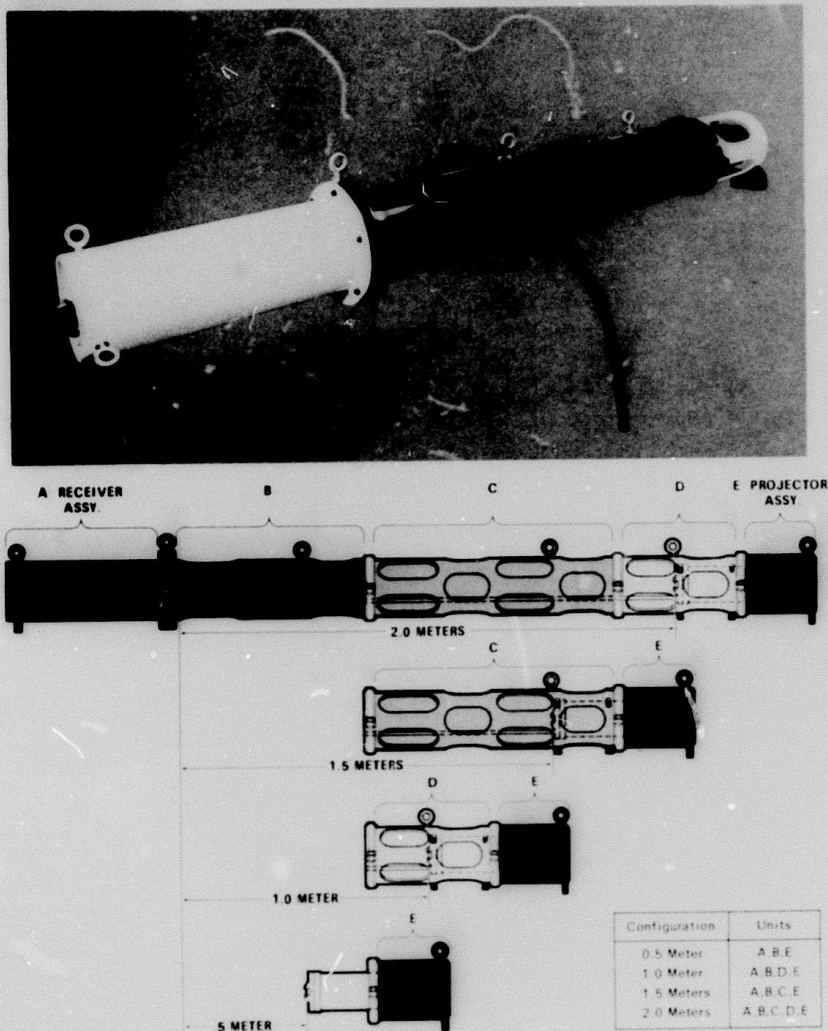

Fig. 5

Electronic Design

The electronics may be divided into two distinct parts: (1) the analog signal detection and processing circuits, and (2) the Digital Data And Command Transmission System (DiDACTS). Figure 6 is an abridged block diagram of the underwater unit. The multiplexer/analog-to-digital converter is the essential interface between the analog and digital circuits.

Underwater Analog Circuitry

An optoelectric coupler (LED/photodiode unit) senses the position of the indexing stop wheel and provides timing signals for the signal detection process. The primary photodetector is a 9-stage photomultiplier tube (RCA 1P28AV1). The gain of this tube is adjusted by controlling the high voltage applied to its dynodes in a manner described later. The output signal from the tube consists of a series of six discrete current levels corresponding to the six positions of the stop wheel. The current is converted to a voltage signal by an operational amplifier, and this voltage is, in turn, applied to the inputs of six sample-and-hold circuits. These circuits are switched by the timing signal generated by the stop wheel location. Thus the D.C. outputs of these S&H circuits correspond to the average value of the photomultiplier tube output during the sampling aperture. These signals are the voltage analogs of the light flux entering the integrating sphere and are updated once per revolution of the stop wheel. The output signals, corresponding to VSF (σ_1 , σ_2 , and σ_3) and transmittance, are applied directly to the analog multiplexer. In addition, the transmittance signal is applied to a logarithmic circuit which provides an output voltage analog of the volume attenuation coefficient α , i.e., $\alpha = -1/\ell \ln T$.

