

3 FG

ADA019216

**WIND AND TURBULENCE INFORMATION FOR VERTICAL  
AND SHORT TAKE-OFF AND LANDING (V/STOL) OPERATIONS  
IN BUILT-UP URBAN AREAS  
- RESULTS OF METEOROLOGICAL SURVEY**

J. V. Ramsdell

> **Atmospheric Sciences Department  
BATTELLE, PACIFIC NORTHWEST LABORATORIES  
Battelle Boulevard  
Richland, Washington 99352**



**JUNE 1975**

FINAL REPORT

Document is available to the public through the  
National Technical Information Service,  
Springfield, Virginia 22161.

D D C  
RECEIVED  
JAN 12 1976  
D

Prepared for

**U.S. DEPARTMENT OF TRANSPORTATION  
FEDERAL AVIATION ADMINISTRATION  
Systems Research & Development Service  
Washington, D.C. 20590**

**NOTICE**

This document is disseminated under the sponsorship of the Department of Transportation in the interest of information exchange. The United States Government assumes no liability for its contents or use thereof.

1. Report No. FAA-RD 75-94	2. Government Accession No.	3. Recipient's Catalog No. <b>(11)</b>	
4. Title and Subtitle Wind and Turbulence Information for Vertical and Short Take-Off and Landing (V/STOL) Operations in Built-Up Urban Areas <del>Results of Meteorological Survey</del>		5. Report Date June 1975	6. Performing Organization Code
10. Author J. V. Ramsdell	8. Performing Organization Report No. <b>(12) 447p.</b>		10. Work Unit No. (TRATS)
9. Performing Organization Name and Address Battelle, Pacific Northwest Laboratories Battelle Boulevard Richland, Washington 99352		11. Contract or Grant No. DOT-FA72 WAI-263 NEW	
12. Sponsoring Agency Name and Address Department of Transportation Federal Aviation Administration System Research and Development Service Washington, D.C. 20590		13. Type of Report and Period Covered Final Report	
14. Sponsoring Agency Code		15. Supplementary Notes	
<p>16. Abstract</p> <p>Winds and turbulence have been measured at typical urban STOL and VTOL port sites and at a conventional rural airport during a 9-month period. These measurements have been used to develop a set of turbulence models for use in: design of V/STOL aircraft stability and control features, development of airworthiness criteria for certification of V/STOL aircraft, and simulation of the turbulence in the urban terminal environment of V/STOL aircraft. The model set includes spectral models, rms gust velocity models and turbulence length scale models. Probability distributions are given for gust velocities and length scales. The data obtained during the study and the models derived therefrom are compared with conventional, flat-terrain turbulence models and data.</p> <p>&gt; In addition, the report contains a review of atmospheric boundary layer theory and descriptions of the measurement sites, instrumentation and data processing. There is a discussion of spatial aspects of turbulence and an evaluation of the standard airport cup anemometer.</p> <p>The appendices contain extensive summaries of the data collected. These summaries include: wind roses, wind and turbulence statistics for selected periods, turbulence spectra, gust velocity distributions, and length scale distributions.</p>			
17. Key Words V/STOL aircraft terminal operations, urban winds, turbulence models, gust velocities, turbulence length scales, turbulence data, instrumentation		18. Distribution Statement Document is available to the public through the National Technical Information Service, Springfield, Virginia 22161.	
19. Security Classif. (of this report) UNCLASSIFIED	20. Security Classif. (of this page) UNCLASSIFIED	21. No. of Pages 42	22. Price

408 668 ✓

mtb

# METRIC CONVERSION FACTORS

## Approximate Conversions from Metric Measures

Symbol	When You Know	Multiply by	To Find	Symbol
<b>LENGTH</b>				
mm	millimeters	0.04	inches	in
cm	centimeters	0.4	inches	in
m	meters	3.3	feet	ft
m	meters	1.1	yards	yd
km	kilometers	0.6	miles	mi
<b>AREA</b>				
cm <sup>2</sup>	square centimeters	0.16	square inches	in <sup>2</sup>
m <sup>2</sup>	square meters	1.2	square yards	yd <sup>2</sup>
km <sup>2</sup>	square kilometers	0.4	square miles	mi <sup>2</sup>
ha	hectares (10,000 m <sup>2</sup> )	2.5	acres	ac

## MASS (weight)

g	grams	0.035	ounces	oz
kg	kilograms	2.2	pounds	lb
t	tonnes (1000 kg)	1.1	short tons	st

## VOLUME

ml	milliliters	0.03	fluid ounces	fl oz
l	liters	2.1	pints	pt
l	liters	1.06	quarts	qt
l	liters	0.26	gallons	gal
m <sup>3</sup>	cubic meters	35	cubic feet	ft <sup>3</sup>
m <sup>3</sup>	cubic meters	1.3	cubic yards	yd <sup>3</sup>

## TEMPERATURE (exact)

°C	Celsius temperature	9/5 (then add 32)	Fahrenheit temperature	°F
----	---------------------	-------------------	------------------------	----

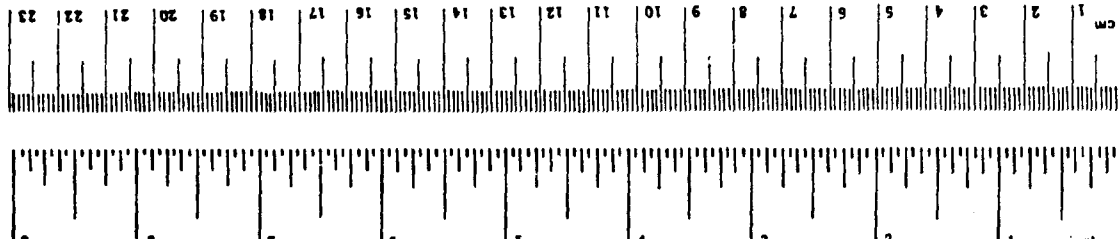

## Approximate Conversions to Metric Measures

Symbol	When You Know	Multiply by	To Find	Symbol
<b>LENGTH</b>				
in	inches	2.5	centimeters	cm
ft	feet	30	centimeters	cm
yd	yards	0.9	meters	m
mi	miles	1.6	kilometers	km
<b>AREA</b>				
in <sup>2</sup>	square inches	6.5	square centimeters	cm <sup>2</sup>
ft <sup>2</sup>	square feet	0.09	square meters	m <sup>2</sup>
yd <sup>2</sup>	square yards	0.8	square meters	m <sup>2</sup>
mi <sup>2</sup>	square miles	2.6	square kilometers	km <sup>2</sup>
ac	acres	0.4	hectares	ha

## MASS (weight)

oz	ounces	28	grams	g
lb	pounds (2000 lb)	0.45	kilograms	kg
		0.9	tonnes	t

## VOLUME

tsp	teaspoons	5	milliliters	ml
Tbsp	tablespoons	15	milliliters	ml
fl oz	fluid ounces	30	milliliters	ml
c	cups	0.24	liters	l
pt	pints	0.47	liters	l
qt	quarts	0.95	liters	l
gal	gallons	3.8	liters	l
ft <sup>3</sup>	cubic feet	0.03	cubic meters	m <sup>3</sup>
yd <sup>3</sup>	cubic yards	0.76	cubic meters	m <sup>3</sup>

## TEMPERATURE (exact)

°F	Fahrenheit temperature	5/3 (after subtracting 32)	Celsius temperature	°C
----	------------------------	----------------------------	---------------------	----

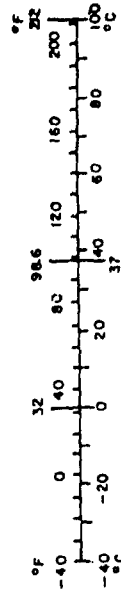

\* 1 in. = 2.54 exactly. For other exact conversions and more data see tables, see NBS Misc. Publ. 236, Units of Weights and Measures, Price \$2.25, SD Catalog No. C1310-236.

ADDITION FOR	
NTIS	Write Section <input checked="" type="checkbox"/>
DOC	Buff Section <input type="checkbox"/>
UNANNOUNCED	<input type="checkbox"/>
JUSTIFICATION.....	
BY.....	
DISTRIBUTION/AVAILABILITY CODES	
Dist.	AVAIL. and/or SPECIAL
A	

PREFACE

This report is submitted by Battelle, Pacific Northwest Laboratories, in partial fulfillment of Interagency Agreement DOT-FA72WAI-263 between The Department of Transportation, Federal Aviation Administration and the United States Atomic Energy Commission, Subject: "Meteorological Analysis and Survey for Representative V/STOL Sites."

The effort was sponsored and administered by the Aviation Weather Systems Branch, Airport Division, Systems Research and Development Service of the Federal Aviation Administration. Mr. Arthur Hilsenrod was the FAA Technical Representative.

The successful completion of large research projects is, by and large, the result of the efforts of many individuals. At this time the author would like to acknowledge and thank those individuals who have assisted during the course of this work. Mr. A. G. Dunbar designed and supervised installation of the instrumentation systems. Mr. R. W. Walters was instrumental in obtaining permission to use the survey sites, and city and state permits in addition to his assistance in instrument maintenance. Messrs. O. B. Abbey, W. F. Sandusky, and J. C. Eraper conducted the major portion of the field work and were responsible for routine instrument system maintenance, and Messrs. D. W. Glover, V. T. Henderson, J. W. Sloat and F. B. Steele assisted in the installation and removal of the instrumentation systems, both occurring under adverse weather conditions. Mr. K. M. Busness of the Battelle, Systems Department provided the necessary computer related technology. This group deserves much of the credit for the results obtained during the survey.

Mr. G. H. Clark of the Australian Atomic Energy Commission, temporarily assigned to Battelle, and Dr. D. C. Powell assisted in the analysis and interpretation of the data. Their contributions are greatly appreciated.

Special thanks go to Mrs. Lois Lee who spent many hours deciphering handwritten manuscript and transcribing it into readable form, to R. L. Conley and E. H. Phinney who shouldered the burden of many details such as graphics and proofreading for the final manuscript, and to Dr. C. E. Elderkin who has provided support and direction throughout the study.

## TABLE OF CONTENTS

	<u>Page</u>
PREFACE	iii
LIST OF TABLES	x
LIST OF FIGURES	xii
LIST OF SYMBOLS, SUBSCRIPTS AND ABBREVIATIONS	xvii
ABSTRACT	xxii
CHAPTER 1. INTRODUCTION	1
INTERIM REPORT REVIEWED	2
FINAL REPORT OUTLINED	5
CHAPTER 2. REVIEW OF BOUNDARY LAYER THEORY	11
WIND PROFILE THEORY	11
EFFECTS OF ATMOSPHERIC STABILITY	13
EFFECTS OF A CHANGE IN SURFACE ROUGHNESS	14
BOUNDARY LAYER TURBULENCE	21
CHAPTER 3. SITE DESCRIPTION	25
LAKE UNION	28
KIXI	29
SEA-TAC	35
CHAPTER 4. SURVEY INSTRUMENTATION	39
WIND INSTRUMENTATION	39
Gill Anemometer	40
Cup Anemometer and Vane	43
Sonic Anemometers	45
TEMPERATURE INSTRUMENTATION	45
SUPPORTING METEOROLOGICAL MEASUREMENTS	46
INSTRUMENT ARRAYS	48

	<u>Page</u>
CHAPTER 5. DATA COLLECTION AND ANALYSIS	53
INFORMATION FLOW AT THE SURVEY SITES	53
Metrodata Tape System	55
Direct Recording System	57
OBSERVATION PROGRAMS	58
Intensive Measurement Program	59
Climatological Measurement Program	60
DATA ANALYSIS	62
Preparatory Processing	62
Analysis	64
CHAPTER 6. PRELIMINARY RESULTS	72
WIND CLIMATOLOGY	72
DETERMINATION OF ATMOSPHERIC STABILITY	80
EVALUATION OF THE ROUGHNESS LENGTH AT LAKE UNION	85
EFFECTS OF THE LENGTH OF OBSERVATION ON WIND PARAMETERS	88
CHAPTER 7. WIND COMPONENT POWER SPECTRA	91
SCALING OF THE SPECTRA	91
LAKE UNION SPECTRA	92
KIXI SPECTRA	99
INTERSITE SPECTRAL COMPARISONS	101
FURTHER SPECTRAL COMPARISONS	104
CHAPTER 8. SPECTRAL MODELS FOR THE URBAN ENVIRONMENT	109
BASIC SPECTRAL MODEL	109
MODEL DEVELOPMENT	110
MODEL PARAMETER EVALUATION	111
FINAL SPECTRAL FORMS FOR AERONAUTICAL USE	113
CHAPTER 9. GUST VELOCITIES	116
OBSERVED RMS GUST VELOCITIES	116

	<u>Page</u>
CHAPTER 9. (continued)	
TURBULENCE INTENSITIES	120
Effect of stability on Turbulence Intensities	120
Effects of Wind Speed, Surface Roughness and Height on Turbulence Intensities	120
RMS GUST VELOCITY MODELS, AVERAGE VALUES	125
Upper Level Gust Velocities Based on Surface Winds	129
RMS GUST VELOCITY MODELS, FREQUENCY DISTRIBUTIONS	130
RMS GUST VELOCITY MODELS FOR URBAN AND RURAL AIRPORTS	136
CHAPTER 10. TURBULENCE LENGTH SCALES	138
OBSERVED LENGTH SCALES	139
Effects of Atmospheric Stability	139
Effects of Wind Speed, Direction and Height	144
LENGTH SCALE MODELS, AVERAGE VALUES	147
Horizontal Component Length Scales	150
Vertical Component Length Scales	152
Relationship to Spectral Peaks	155
Upper Level Length Scales Based on Surface Winds	157
LENGTH SCALE MODELS, FREQUENCY DISTRIBUTION	158
LENGTH SCALE MODEL EVALUATION	161
Comparison with Data from Other Locations	162
Comparison with Other Models	165
LOCAL ISOTROPY RELATIONSHIPS	171
CHAPTER 11. SPATIAL ASPECTS OF TURBULENCE	174
SPACE-TIME CORRELATIONS	174

	<u>Page</u>
CHAPTER 11. (continued)	
WIND SHEAR	180
CHAPTER 12. THE FAA STANDARD CUP ANEMOMETER AS A TURBU- LENCE SENSOR	187
CUP ANEMOMETER FREQUENCY RESPONSE	187
FREQUENCY RESPONSE CORRECTION	192
LONGITUDINAL RMS GUST VELOCITY MEASURE- MENT	193
LONGITUDINAL LENGTH SCALE ESTIMATES	194
EVALUATION OF THE CUP ANEMOMETER	197
CHAPTER 13. CONCLUSIONS	200
THE SURVEY	201
Major Conclusions	202
Additional Results	204
THE STUDY	206
Selection of V/STOL Port Sites	206
Optimization of Runway Orientation	206
Determination of Method of Estimating Climatological Information	207
Optimization of a Meteorological Measurement System	207
Establishment of Airworthiness Standards	208
Optimization of Stability and Control Features	208
Simulation of V/STOL Aircraft Flight	209
Simulation of Control of Air Traffic	210
THE DATA LEGACY	210
REFERENCES	212
APPENDIX A. WIND ROSES	A-1
APPENDIX B. INTENSIVE MEASUREMENT PROGRAM DATA SUMMARY	B-1
APPENDIX C. INTENSIVE MEASUREMENT PROGRAM SPECTRA	C-1

	<u>Page</u>
APPENDIX D. AVERAGE TURBULENCE INTENSITIES	D-1
APPENDIX E. TURBULENCE INTENSITY DISTRIBUTIONS	E-1
APPENDIX F. AVERAGE TURBULENCE LENGTH SCALES	F-1
APPENDIX G. TURBULENCE LENGTH SCALE DISTRIBUTIONS	G-1

## LIST OF TABLES

<u>Table</u>	<u>Title</u>	<u>Page</u>
1	Estimated interface height in meters as a function of stability, roughness length and distance from a change of roughness.	18
2	Parameters defining the position and shape of the surface area having dominant influence on a point wind measurement.	19
3	Vertical dimensions of major buildings of the Seattle central business district.	34
4	Position of towers and instruments at the survey sites.	50
5	Approximate degrees of freedom of the distribution of banded spectral estimates for data from the intensive and climatological observations.	69
6	Factors to determine the range in which true spectral values can be expected.	70
7	Relationship between nondimensional wind shear and nondimensional height.	82
8	Variation of wind parameters and stability during the night of January 12, 1974.	83
9	Comparison of wind statistics from extended run and climatological measurements made at approximately the same time.	89
10	Initial parameter values for the spectral model.	113
11	Revised parameter values for the spectral model.	113
12	Average turbulence intensities by wind direction and height for wind speeds between 3 and 5 m/s.	123
13	Average turbulence intensities by wind speed and height for air flowing over regions of contrasting roughness in an urban area.	124
14	Average rms gust velocities for flow over smooth and rough terrain.	127

<u>Table</u>	<u>Title</u>	<u>Page</u>
15	Parameter values for rms gust velocity models for flow over rough and smooth terrain.	135
16	Model parameters for rms gust velocity models for urban and rural airports.	136
17	Average length scales in meters by wind direction and height for wind speeds between 3 and 5 m/s.	145
18	Average length scales in meters by wind speed and height for airflow over regions of contrasting roughness.	146
19	The variation of integral time scales with height and wind speed.	149
20	Length scale model parameter values.	157
21	Standard deviations of $\ln(L_y)$ .	161
22	Length scale model summary.	166
23	Evaluation of the Dryden spectra isotropy relationships.	172
24	Evaluation of the von Karman spectra isotropy relationships.	173
25	Space-time correlogram interpretation.	180
26	Observed vertical wind shear and moments.	184
27	Comparison of Gill and cup anemometer average wind speeds and turbulence model parameter estimates.	198

## LIST OF FIGURES

<u>Figure</u>	<u>Title</u>	<u>Page</u>
1	The variation of a boundary layer wind profile under different conditions of atmospheric stability.	15
2	Effect of a rough to smooth change in surface roughness on wind profiles. In region A the profile is unchanged. In region B the profile is in a transition state, and in region C the wind profile has fully adjusted to the new surface.	17
3	Estimated surface area having the dominant influence on the wind at a point above the surface. Typical dimensions for the surface area are given in Table 2.	20
4	Topography of Seattle in the vicinity of the survey measurement sites. Fifty-foot elevation contours are shown.	27
5	Lake Union survey site and upwind fetch to the northwest.	30
6	View of the Tower 801 Apartments and the KIXI measurement site.	32
7	Street map of the Seattle central business district showing the locations of the major buildings. The building numbers are keyed to Table 3 which gives the names, vertical dimensions and year of construction of the buildings.	33
8	View of the central business district to the south of the KIXI site. The photograph was taken from the KIXI site.	36
9	View of the urban area to the north of the KIXI site. The photograph was taken from the KIXI site.	37
10	View of the SEA-TAC measurement site, looking southeast.	38
11	Comparison of mean speeds measured by the Gill and cup anemometers.	44

<u>Figure</u>	<u>Title</u>	<u>Page</u>
12	Relative positions of the towers at the Lake Union Site. Distances between towers in meters.	49
13	Information flow at the survey sites.	54
14	Comparison of frequencies of occurrence of wind directions observed during the survey. Height of observation about 7 m at SEA-TAC and Lake Union and 77 m at KIXI.	74
15	Cumulative distributions of observed wind speeds at SEA-TAC, including comparison with climatological expectation and the distribution assumed in the Interim Report.	76
16	Cumulative distributions of observed wind speeds at Lake Union.	77
17	Cumulative distributions of observed wind speeds at KIXI.	78
18	Joint distribution of the adiabatic, $k\Delta u/\ln(z_2/z_1)$ , and diabatic, $u_*$ , factors used in the computation of $\phi_m$ for 37 extended tests at Lake Union.	84
19	Variation in the roughness length, $z_0$ , as a function of wind direction and stability.	86
20	Wind profiles in stable, neutral and unstable conditions showing the extrapolation to determine $z_0$ .	87
21	Composite wind profile for the extended tests at Lake Union.	93
22	Composite spectra for the Lake Union intensive measurement data.	94
23	Lake Union 6.9 m extended test composite spectra normalized to $u_*^2$ .	97
24	Lake Union 48.2 m extended test composite spectra normalized to $u_*^2$ .	98
25	Composite spectra for the KIXI intensive measurement data.	100

<u>Figure</u>	<u>Title</u>	<u>Page</u>
26	Comparison of composite spectra from the nominal 7 m level at the 3 survey sites.	102
27	Comparison of composite spectra from the nominal 25 m level at the 3 survey sites.	103
28	Comparison of Brook's average spectral estimates and the von Karman spectral model with Lake Union 6.9 m data.	105
29	Comparison of the von Karman spectral model with KIXI upper level data.	106
30	Ratios of rms gust velocities to the shear stress as a function of $\phi_m$ for the extended tests at Lake Union.	112
31	Suggested atmospheric spectral models.	115
32	Cumulative frequency distributions of observed rms longitudinal gust velocities.	117
33	Cumulative frequency distributions of observed rms lateral gust velocities.	118
34	Cumulative frequency distributions of observed rms vertical gust velocities.	119
35	Turbulence intensities as a function of $\phi_m$ for the extended tests at Lake Union.	121
36	Variation of the average rms gust velocities observed for the sectors of contrasting surface roughness at the survey sites.	128
37	Frequency distribution of longitudinal rms gust velocities observed at Lake Union during southerly winds between 3 and 5 m/s.	131
38	Frequency distribution of longitudinal rms gust velocities observed at KIXI during southerly winds between 3 and 5 m/s.	132
39	Frequency distribution of longitudinal rms gust velocities observed at SEA-TAC during westerly winds between 3 and 5 m/s.	133

<u>Figure</u>	<u>Title</u>	<u>Page</u>
40	RMS gust velocities for typical urban and rural airports.	137
41	Cumulative frequency distributions of observed longitudinal gust length scales.	140
42	Cumulative frequency distributions of observed lateral gust length scales.	141
43	Cumulative frequency distributions of observed vertical gust length scales.	142
44	Integral length scales as a function of $\phi_m$ for the extended tests at Lake Union.	143
45	Variation of the horizontal component time scales with wind speed at the height of measurement.	151
46	Variation of the vertical component time scale with height by wind speed categories.	153
47	Vertical component time scale normalized to $\ln z$ as a function of wind speed.	154
48	Frequency distributions of vertical length scales at Lake Union.	160
49	Comparison of the suggested longitudinal length scale model and survey data with data from other sites.	163
50	Comparison of the suggested vertical length scale model and survey data with data from other sites.	164
51	Comparison of longitudinal length scale models.	168
52	Comparison of lateral length scale models.	169
53	Comparison of vertical length scale models.	170
54	Space-time correlations with a 6.2 m/s wind parallel to the longitudinal axis of the Lake Union tower array.	176

<u>Figure</u>	<u>Title</u>	<u>Page</u>
55	Space-time correlations with a 11.5 m/s wind at an angle of 24° to the longitudinal axis of the Lake Union tower array.	177
56	Hypothetical space-time correlation for flight in a direction parallel to the mean wind vector.	179
57	Composite longitudinal gust power spectrum for Lake Union from FAA standard cup anemometer measurements.	189
58	Comparison of cup and Gill anemometer longitudinal gust power spectra.	190
59	Comparison of longitudinal rms gust velocities determined from cup and Gill anemometer measurements.	195
60	Comparison of longitudinal length scales determined from cup and Gill anemometer measurements.	196

## LIST OF SYMBOLS, SUBSCRIPTS AND ABBREVIATIONS

$A_{\gamma}$	Constant relating the $\gamma$ component wave length and integral time scale.
$a, b$	Major and minor axes of elliptical area on the surface in which the roughness significantly affects the turbulence at an elevated position downwind. (Chapter 2 only).
$a, b$	Coefficients in the relationship between rms gust velocities and wind speed (Chapter 7).
$a_{\gamma}, b_{\gamma}$	Slope and intercept in the linear relationship between the $\gamma$ component rms gust velocity and wind speed.
$B_{\gamma}$	Constant relating the $\gamma$ component time scale to the wind speed.
BCD	Binary coded decimal.
$C_{\gamma}$	Coefficient in $\gamma$ component spectral model.
$c$	Subscript indicating cup anemometer.
$c_{\gamma}$	Exponent in the relationship between the $\gamma$ component time scale and wind speed.
cm	Centimeter.
$D_{\gamma}$	Product of $A_{\gamma}$ and $B_{\gamma}$ .
$F_c(n/\bar{u})$	Filtering function which describes the behavior of the cup anemometer power spectrum as a function of $n/\bar{u}$ .
$f$	Nondimensional frequency, $nz/\bar{u}$ .
$f_m$	Nondimensional frequency at which $nS(n)$ is maximum.
ft	Feet.

g	Subscript referring to Gill anemometers.
H	Height of the interface between the unchanged and transition flow after a change in surface roughness.
Hz	Hertz, (frequency) in units 1/sec.
h	Height.
i,j,k	Subscripts indicating direction, may be replaced by 1, 2, or 3 or equivalently x, y, z.
k	Wave number, radians/sec.
km	Kilometer.
L	Monin-Obukhov length.
$L_a$	Anemometer distance constant.
$L_y$	Length scale for the y velocity component.
$L'_y$	Product of $L_y$ and $A_y$ .
m	Meters.
mph	Miles per hour.
m/s	Meters per second.
mV	Millivolt.
msl	Mean-sea-level.
n	Frequency in Hz.
$P(\bar{u})$	Conditional probability given the mean wind speed.
P	Integer exponent.
$R_y(t)$	Autocorrelation for y component velocity at time lag t.
r	Subscript indicating a reference level.

rms	Root-mean-square, standard deviations, (variance) <sup>1/2</sup> .
$r_\gamma$	Shape parameter in the $\gamma$ component spectral model.
$S_{ij}$	Wind shear tensor.
$S(n), S(k)$	Power spectral estimate for the $\gamma$ component at frequency $n$ or wave number $k$ .
$S^*( )$	Power spectral estimate corrected for instrument response.
$s, \text{ sec}$	Seconds (time).
$s_\gamma$	Standard deviation of the natural logarithms of the $\gamma$ component rms gust velocity.
$s'_\gamma$	Standard deviation of the natural logarithms of the $\gamma$ component length scale.
$T$	The length in time of a time series.
$t$	Time or time lag.
$\bar{u}$	Mean wind speed (normally parallel to the x-axis).
$u', v', w'$	Departures of the wind components from the mean velocity.
$\hat{u}$	A general characteristic velocity.
$u_*$	A characteristic velocity related to the surface stress.
$u(t), u(z)$	Wind speed at time $t$ or height $z$ .
$u'(t), v'(t), w'(t)$	Instantaneous departure of the wind component velocities from the mean velocity at time $t$ .
$\bar{v}$	Mean lateral wind velocity, equal to zero when the x-axis is aligned parallel to the mean wind vector.

$v_a$	Aircraft velocity component parallel to the mean wind vector.
X	Horizontal distance.
x,y,z	Axes in right handed cartesian coordinate system, the x-axis is usually aligned parallel to the mean wind vector, also distances along the axes.
$x_0$	A reference location.
$\hat{z}$	A general characteristic length.
$z_0$	A characteristic length called the surface roughness length, a constant of integration in the logarithmic wind profile.
Y	A general index to indicate variation between turbulence components, may be replaced by u, v, w, and in some cases c.
$\theta$	Wind direction, an angle.
$\kappa$	von Karman's constant, taken to be 0.35
$\lambda_m$	Wave length at which $nS(n)$ is a maximum.
v	Degrees of freedom in the banded spectral estimates.
$\rho$	Density.
$\sigma_u^2, \sigma_v^2, \sigma_w^2$	Variances of $u'$ , $v'$ , and $w'$ .
$\sigma_u, \sigma_v, \sigma_w$	RMS gust velocities for the longitudinal, lateral and vertical components of the wind.
$\sigma_s^2$	variance of the turbulent component of the wind shear.
$\tau$	Integral time scale.
$\tau_Y$	Integral time scale for the $\gamma$ component velocity.
$\tau_0$	Surface stress.

$\phi_m$

Nondimensional wind shear; used as an indication of atmospheric stability.

$\psi$

An angle.

## ABSTRACT

The Systems Research and Development Service of the Federal Aviation Administration has sponsored a study of meteorological information for typical urban port sites for vertical and short take-off and landing (V/STOL) aircraft. The results of an analysis of readily available data have been presented in an earlier report, "Meteorological Information for Vertical and Short Take-Off and Landing (V/STOL) Operations in Built-Up Urban Areas - An Analysis," FAA-RD-72-135 (Ramsdell and Powell, 1973). That report listed important information deficiencies relating to wind and turbulence in urban areas and outlined a meteorological survey to provide needed information. This report presents the results of the completed survey.

Survey measurements were made at three locations in the vicinity of Seattle, Washington. The primary measurement location was a ground-level site on the shoreline of Lake Union north of the central business district. The Lake Union site was typical of potential V/STOL port sites. The top of a 26-story building within the central business district provided the second measurement location and the third location was at the Seattle-Tacoma Airport, just west of the runway. These sites were typical of an elevated VTOL port and a conventional airport, respectively.

Turbulence information used in aircraft design, flight simulation and certification is generally based on observations of turbulence over flat, rural terrain. This information is not applicable *a priori* to the anticipated urban terminal environment of V/STOL aircraft. Thus, a major goal

of the survey was to obtain a description of turbulence in the urban environment. This goal was attained, and the desired description is embodied in a set of turbulence models developed using survey data. These models are described in the report and are intended for use in simulation of flight of V/STOL aircraft and the development of airworthiness standards.

A second major result applicable to the foregoing areas of interest is the identification of the probability distributions of the turbulence descriptors, i.e., gust velocities and length scales, which are used as parameters in turbulence models. With these distributions, the turbulence models, and a probability distribution of wind speed (e.g., Figure 3-1 of Barr, Gangsaas and Schaeffer, 1974), it is possible to estimate the probability of occurrence of a given turbulence environment at either an urban V/STOL port site or a conventional airport.

Decisions in airport siting often must be made before standard meteorological measurements and climatological techniques can provide useful data. Combined with the wind rose extrapolation model described in the Interim Report, the turbulence models provide a set of models which can be used to estimate climatological information on wind and turbulence at potential V/STOL port sites reliably and efficiently. Through these results, the survey and the analysis have provided techniques for use in selection of V/STOL port sites and optimization of runway orientation.

Additional results include the description of the dynamic response of the standard airport cup anemometer to turbulence. Although the cup anemometer is not a true turbulence sensor, turbulence information useful for operational and climatological purposes can be obtained from it. Other results describe

the spatial aspects of turbulence. These results should be of interest in flight simulation and the design and certification of V/STOL aircraft.

The information developed is of limited value in air traffic control simulations because of limitation of the study to consideration of the lowest 200-300 ft of the atmosphere. However, the discussion of observed wind shear and the decomposition of shear into average and turbulent parts is generally applicable to a deeper layer of the atmosphere. Information on turbulence may also be of value if it can be related to the probability that a given approach will end in a missed approach.

The final chapter of the report contains a detailed listing of major and minor conclusions drawn from the survey data. It also contains a review of the objectives of the study in which results are matched with the objectives.

The detailed results presented throughout this report and the data contained in the Appendices are specifically intended for aeronautical application to the design, certification and operation of V/STOL aircraft. In a more general sense, however, the report should provide much needed information on wind and turbulence in urban areas for application to building design and air quality control problems.

## CHAPTER 1

### INTRODUCTION

The development of a short-haul air transportation system may result in scheduled commercial operation of vertical and short take-off and landing (V/STOL) aircraft from airports in built-up urban areas. To aid in the satisfactory development of this system and to ensure the safe and expeditious operation of V/STOL aircraft, Battelle, Pacific Northwest Laboratories, has evaluated the potential meteorological problems associated with aircraft terminal operations in this environment. The initial analysis determined meteorological information needed for:

- Selection of V/STOL port sites.
- Optimization of runway orientation at V/STOL ports.
- Determination of efficient and reliable methods of estimating climatological information on those meteorological variables significant to V/STOL operations at potential port sites.
- Optimization of a meteorological observation system for V/STOL ports.
- Establishment of airworthiness standards for V/STOL aircraft operations.
- Optimization of stability and control features for V/STOL aircraft.
- Simulation of V/STOL aircraft flight.
- Simulation of control of air traffic.

Availability and limitations of the existing information were identified and a meteorological survey was designed to overcome the limitations. An Interim Report (Ramsdell and Powell, 1973) has been issued which describes the results of the analysis phase of the study in detail. Following the analysis phase, the survey was undertaken to provide meteorological information where limitations existed. This report contains the results of that survey.

#### INTERIM REPORT REVIEWED

Prior to beginning the discussion of the meteorological survey and its results, it is appropriate to review the background information which led to the survey. In the study leading to the Interim Report several information deficiencies and problem areas were noted. The most significant information deficiencies were related to the wind. Two problem areas in communications between meteorologists and the aeronautical engineering community were noted. Finally, a deficiency in the information on ceilings and visibility in urban areas was noted.

Turbulence information deficiencies dominate the deficiencies in the wind category both in number and in seriousness. Turbulence is significantly related to aircraft handling and ride qualities. For this reason turbulence information deficiencies have an impact on each of the eight areas of inquiry. The relationship between turbulence and the areas of design of stability and control features, flight simulation and the establishment of airworthiness criteria are obvious. When it is remembered that the roughness surrounding an airport may control the turbulence at the airport, the importance of turbulence considerations in V/STOL port siting and determination

of runway orientation is apparent. The same argument can be extended to relate turbulence to each of the other areas.

Information on turbulence existing at the time of the initial study indicated that urban areas increased the level of turbulence and caused the shift of turbulence energy to higher frequencies in the turbulence spectra. Results of flight simulation suggested that this urban modification of the turbulence would have adverse effects on handling and ride qualities of V/STOL aircraft and on their operation. Further, the fragmentary meteorological information available suggested that the modification might be significant. Thus, the necessity of additional turbulence measurements in urban areas was clearly indicated as the only means of providing adequate descriptions of turbulence in this environment. Boundary layer turbulence theory can not treat the complex boundary conditions found in the urban area.

Since an adequate description of urban turbulence did not exist, turbulence models used in flight simulation for design or airworthiness certification were suspect. The von Karman, Dryden and other spectral models derived from atmospheric data do not apply *a priori* in the urban environment. Thus, urban turbulence data were needed to evaluate the suitability of existing turbulence models.

Not only is it necessary to be able to describe the urban turbulence through models, but it is also necessary to describe the frequency of occurrence of various levels of turbulence. Existing meteorological data did not provide information adequate to assess the frequency of occurrence of either of the parameters of turbulence models. Again a turbulence measurement program was indicated.

Finally, a cursory examination of the assumption that an aircraft at low altitude may be treated as a point mass indicated that the assumption was invalid. As a result, spatial characteristics of turbulence assume increased importance. Meteorological data which could be used to evaluate the spatial variability of turbulence on the scale of characteristic aircraft dimensions were nonexistent for built-up urban areas and only limited data were available for rural locations.

Two additional inadequacies were noted with respect to wind. These were an inability to estimate the frequency of occurrence of turbulence levels on the basis of readily available climatological information, and the lack of a rational technique for efficiently estimating wind roses at potential V/STOL port sites. The latter deficiency was important since optimization of orientation of a V/STOL port runway is based upon data contained in the wind rose for the site and an improperly oriented runway could cause a sizable reduction in the usability of a V/STOL port due to excessive crosswinds. A technique for climatological extrapolation of wind roses was proposed in the Interim Report to remedy this deficiency.

A review of the literature while attempting to identify potentially significant meteorological problems associated with urban terminal operations of V/STOL aircraft brought to light two areas where communications problems hinder the interchange of information between meteorologists and the aeronautical engineering community. Frequently, engineers were not aware of the results of atmospheric turbulence research and, at the same time, meteorologists were not aware of the specific needs of engineers. This lack of communications results in part because each discipline has developed a different nomenclature and symbolism for atmospheric phenomena. The second problem arises

in interpretation of the results of flight simulations. There is a general tendency to relate evaluation of aircraft performance to parameters of turbulence models rather than to the actual turbulence simulation produced by models. Specific characteristics of the turbulence are more significant to the aircraft than rms gust velocities or turbulence length scales. The identification of those characteristics which are responsible for marginal or unacceptable aircraft performance is needed before meteorologists can assess the adequacy of existing turbulence models or develop better models for use by the aeronautical community.

Finally, there was a lack of meteorological information which could be used to evaluate the effect of an urban area on ceilings and visibility.

#### FINAL REPORT OUTLINED

This report presents the results of the meteorological survey which was conducted in Seattle, Washington, to obtain the information needed to overcome the information deficiencies which have just been described. Because the most significant of the information deficiencies were related to turbulence, the analysis of data collected during the survey has proceeded primarily in that direction. The results of that analysis and the summarization of the wind and turbulence data collected during the survey, therefore, comprise the bulk of this report. There is a large quantity of meteorological data collected during the survey which has, as yet, not been analyzed or has received only cursory analysis. This includes pressure, temperature, humidity, visibility, solar radiation data as well as additional wind and turbulence data.

Organizationally this report is arranged to permit a logical development of information needed to fully describe the measurement program and assess the validity of the results of the data analysis. Therefore following this introduction, in order, are sections covering: boundary layer theory, description of the survey sites, the instrumentation used, data collection and preliminary analysis, and major results of the measurement program. At the end of the report are a number of Appendices which contain summaries of data collected during the survey.

The chapter on boundary layer theory (Chapter 2) is presented to establish a basic framework within which the analysis of the wind data can logically be discussed and the results evaluated. It is not rigorous, rather it is a condensation of the information presented in Appendices A and B of the Interim Report. In some cases, however, additional information is presented. The Interim Report and Chapter 2 in this report are referenced in sufficient detail to permit direct access to more detailed discussions of each point. Those who have a basic familiarity with boundary layer theory may wish to bypass this chapter, using it only as needed to clear up questions which may arise.

In the third chapter the measurement sites are described. This chapter, too, is basically a repeat of information contained in the Interim Report although the detailed information in the site descriptions has been expanded. Topographic and street maps of Seattle have been included to permit detailed physical modeling of the area surrounding the measurement sites. In addition, the locations of the major buildings in Seattle have been shown and the vertical dimensions of these buildings are given.

The instrumentation used in the survey is the subject of the fourth chapter. This chapter includes brief descriptions of the instruments used and the arrays in which they were deployed. The Gill anemometers and the FAA standard cup anemometer and wind vane are described and wind speed measurements with the two instruments are compared. Problems which prevented the use of sonic anemometers at Lake Union are described. In addition, the exact locations of instruments within the arrays are given.

The fifth chapter contains a discussion of the flow of information from the survey instruments through preliminary computer analysis. Two separate wind measurement programs were conducted during the survey; one to obtain climatological information and the other to obtain detailed information during periods of particular interest. These programs are described in this chapter. The computer processing of the data is covered, including the editing for spurious signals, corrections for instrument response and the spectral analysis of the data. Other topics covered in Chapter 5 include the computation of time and length scales and the analysis data on the spatial characteristics of turbulence.

The results of the meteorological survey are presented beginning in Chapter 6. This chapter sets the stage for the detailed discussion to be presented in the following six chapters by covering four topics which can at best be described as loosely related. These topics are the "Wind Climatology of the Survey Period," the "Determination of Atmospheric Stability," the "Evaluation of the Roughness Length at Lake Union," and the "Effects of the Length of Observation on Wind Parameters."

Wind component power spectra observed during the survey are discussed in Chapter 7. The initial portion of the chapter

describes the scaling of the frequency axis and variations of the spectra in the vertical. Composite spectra are shown for Lake Union and KIXI. These spectra are then compared with spectra from SEA-TAC. Finally the composite spectra for Lake Union and KIXI are compared with spectral data obtained in Melbourne, Australia and with the von Karman spectral models.

In Chapter 8 a spectral model is fit to the urban composite spectra from the Lake Union Site. The relationships between the wind component rms gust velocities and the friction velocity are examined as a function of stability for use in converting the basic spectral model to a form more familiar in aeronautical applications. Finally, model parameters are evaluated using the data from both the intensive and climatological measurements.

RMS gust velocities, which are parameters of the spectral models, are examined in detail in Chapter 9. The chapter starts with a description of the observed gust velocity distributions and the variation of gust velocities with stability. The variation of rms gust velocities with height, wind direction and wind speed is examined in detail. Finally, models are developed for average rms gust velocities and the distribution of gust velocities about the average.

Turbulence length scales are the second set of parameters used in the spectral models developed in Chapter 8. These are discussed in detail in Chapter 10. The organization of Chapter 10 closely parallels that of the preceding chapter. The distributions of the observed values are described first. The variation of length scales with stability, height, wind direction and wind speed is then examined and a set of length scale models is developed. Models are given for averages and the variation about the average. The average length scale models and

survey length scale data are then compared with previous data and models. In the last section of Chapter 10 survey turbulence data are used to examine the von Karman and Dryden local isotropy relationships between the turbulence component length scales and gust velocities.

In Chapter 11 the discussion shifts from the conventional analysis of turbulence data at a single point in space to analysis of the spatial aspects of turbulence. Space-time correlations are presented for two intensive measurement periods at Lake Union. These correlations are interpreted in terms relative to aircraft flight. The second topic covered under spatial aspects of turbulence is wind shear. Wind shear is separated into steady state (mean) and turbulent components. The components of the vertical shear are then examined in six cases at Lake Union. The mean shear and the standard deviation, skewness and kurtosis are given for each of the three components of the wind vector for vertical separations between 5.7 and 41.3 m.

Chapter 12 returns to considerations of instrumentation. Concurrent sets of data taken with the FAA standard cup anemometers and the adjacent Gill anemometers are used to evaluate the potential of the cup anemometer as a turbulence sensor. The spectrum of longitudinal gusts obtained from the cup shows a marked attenuation of high frequency gusts. However, a comparison between the Gill and cup spectra is used to obtain a transfer function which can be used to correct the cup spectra. Finally, the rms gust velocities and longitudinal component length scales obtained from the cup are compared with those obtained from the Gill.

The conclusions and results of the study are summarized in Chapter 13. In this chapter, a brief review of the

objectives of the measurement program sets the stage for the summary, and the summary ends with a comparison of results and objectives.

## CHAPTER 2

### REVIEW OF BOUNDARY LAYER THEORY

Before becoming involved with the details of the survey it is well to review the basic information on the atmospheric boundary layer although it is acknowledged that this theory and results derived from it generally do apply *a priori* in the urban environment. This section is intended to accomplish that purpose through the presentation of information in a number of rather loosely related areas.

The measurements made during the survey must, initially at least, be considered within the frame of the climatology of the measurement period. Generalization to other times and places can be considered only if the results can be expressed in terms which are independent of the specific measurement period. To establish a basis for discussion of the results in general terms, the topics in this section will review and in some cases expand the information contained in the Appendices (A and B) on the atmospheric boundary layer contained in the Interim Report. Specific topics to be covered include wind profile theory, the effects of atmospheric stability and changes in terrain roughness on wind profiles, wind turbulence spectra, and the effects of variations in sampling and data processing on the results.

#### WIND PROFILE THEORY

The modeling of wind profiles in the lowest layer of the atmosphere is generally a statement of geometric similarity of the form

$$\frac{\bar{u}(z)}{\hat{u}} = \Xi \frac{z}{\hat{z}} \quad (2-1)$$

where  $\Xi$  is a universal function, and  $\hat{u}$  and  $\hat{z}$  are the characteristic velocity and length, respectively. Two forms of the universal function are common, a power law relationship and a logarithmic relationship. The logarithmic function is better supported by theory.

In the surface boundary layer, which can be considered to be the lowest 100 m of the atmosphere for aeronautical engineering purposes, a balance of forces can be assumed between the frictional drag at the surface,  $\tau_0$ , and the turbulent eddy stress above,  $-\rho u'w'$ . Equating these gives a definition of a characteristic velocity

$$\hat{u} = u_* = \sqrt{\frac{\tau_0}{\rho}} \approx \sqrt{-u'w'} \quad (2-2)$$

Under normal circumstances  $u_*$  is considered to be constant in this layer. Assuming that the wind shear,  $\partial \bar{u} / \partial z$ , has the form

$$\frac{\partial \bar{u}}{\partial z} = \frac{u_*}{\kappa z} \quad (2-3)$$

leads directly to the logarithmic profile,

$$\bar{u} = \frac{u_*}{\kappa} \ln\left(\frac{z}{z_0}\right) = \frac{u_*}{\kappa} \ln\left(\frac{z}{z_0}\right) \quad (2-4)$$

where  $\kappa$  is a proportionality constant (von Karman's) and  $z_0 = z$  is a characteristic height determined by extrapolation of the wind profile to the height at which the wind speed would go to zero. The characteristic length,  $z_0$ , is related to the size of the surface roughness elements and therefore called the

roughness length. The preferred value for von Karman's constant for use in atmospheric computations is 0.35 (Businger et al., 1971).

The relationship expressed in Equation (2-4) is strictly applicable at heights considerably larger than the roughness length (perhaps  $z/z_0 > 10$ ) over flat, homogeneous terrain of uniform roughness during conditions of neutral atmospheric stability. The foregoing conditions are not found in the urban environment with any regularity. It is therefore necessary to consider the effects of deviations from these conditions, particularly the variation with respect to stability and roughness changes.

#### EFFECTS OF ATMOSPHERIC STABILITY

In general the atmosphere is not in a neutrally stratified state, but is either stably or unstably stratified. Under these conditions it is necessary to consider the effects of buoyancy in formulation of wind profile models. The currently accepted basis for modeling in the diabatic atmosphere is Monin-Obukhov similarity theory (Obukhov, 1971). In this theory, all heights should be nondimensionalized using the Monin-Obukhov length,  $L$ , which is a measure of atmospheric stability.  $L$  is positive for stable, negative for unstable, and infinite for neutral atmospheres. It is then hypothesized that wind profiles and turbulence characteristics, when suitably nondimensionalized, are universal functions of the nondimensional height,  $z/L$ . In general two relationships are needed for each profile or characteristic, one for stable conditions and the other for unstable.

To develop wind profile models for the stable and unstable cases the differential equation leading to the logarithmic

profile in neutral conditions is rewritten

$$\frac{\kappa z}{u_*} \frac{\partial \bar{u}}{\partial z} = \phi_m(z/L) \quad (2-5)$$

where  $\phi_m$  is called the nondimensional shear. As a result of the dual formulation required to specify  $\phi_m$  in both stable and unstable conditions, two mathematical models are required for the wind profile. Interpretation of the significance of the magnitude of  $\phi_m$  is straightforward. Using the neutral case ( $\phi_m = 1$ ) as a base, during unstable conditions  $\phi_m$  is less than 1 and the wind speed increases relatively less rapidly with height. During stable conditions  $\phi_m$  is greater than 1 and the wind speed increases relatively more rapidly with height. The effect of the change of stability on  $\phi_m$  and the resultant effect on wind profiles is illustrated in Figure 1. Data taken over flat terrain with small roughness elements show extremely good agreement with wind profile models developed in this fashion.

At this point a note is warranted on a quirk of meteorological practice. In Figure 1 it will be observed that height is plotted on the ordinate although it is obviously the independent variable. This is done with some regularity to present a better visualization of the variation of a quantity in space. Care must be taken when relating equations to figures to identify which axes represent the dependent and independent variable.

#### EFFECTS OF A CHANGE IN SURFACE ROUGHNESS

At typical urban V/STOL port sites the condition of uniformly spaced, small roughness elements will be seriously violated. The ramifications of the departure from this condition have been studied in some detail for simple changes in

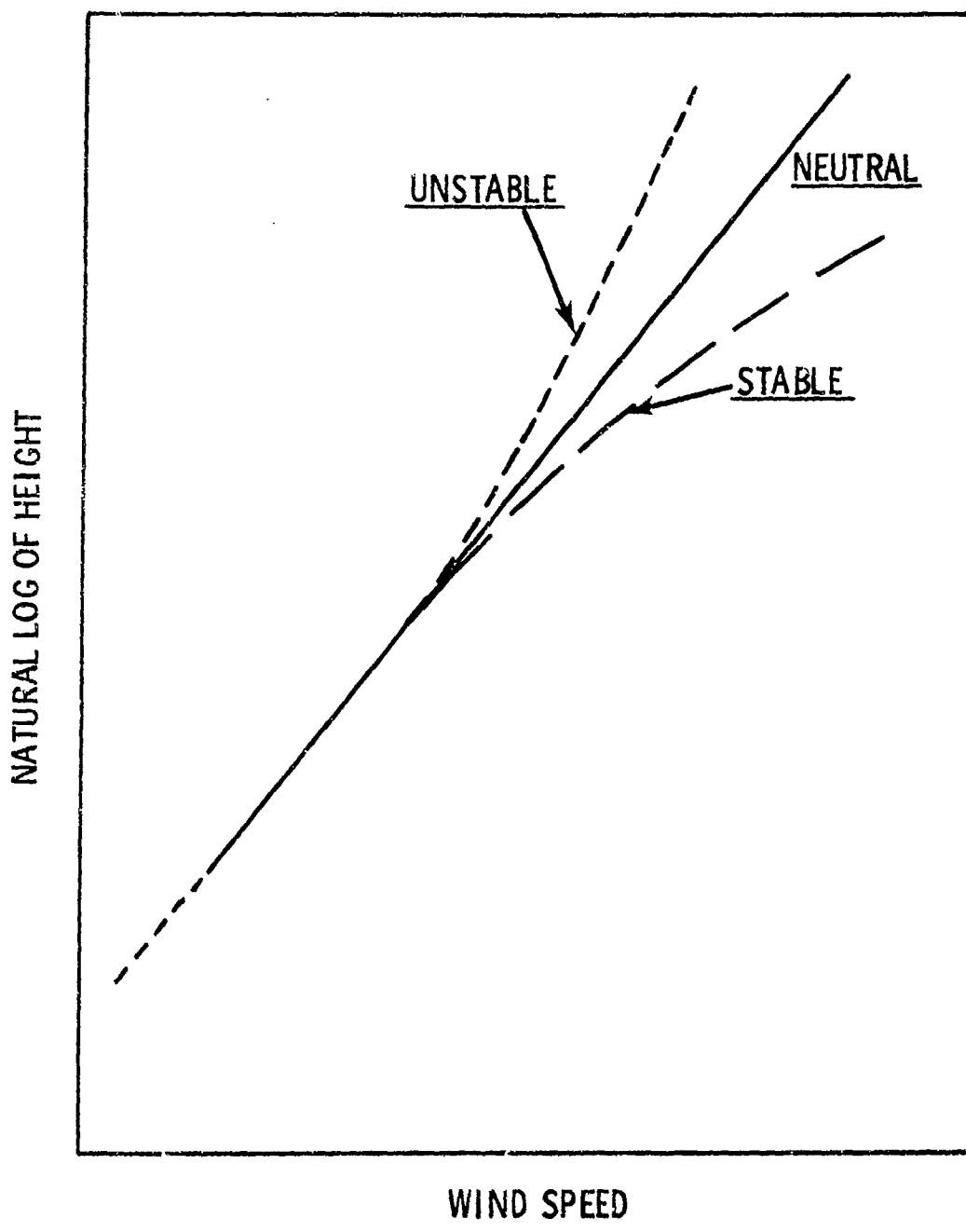

FIGURE 1. The variation of a boundary layer wind profile under different conditions of atmospheric stability.

roughness under neutral conditions (e.g., Bradley, 1968, Taylor, 1969a, 1969b, and Peterson, 1969). Only recently has investigation begun on the effects of change of roughness in non-neutral atmospheres.

The simple two-dimensional case is illustrated in Figure 2. In this figure, with the wind blowing from left to right, the surface roughness elements change in size from large to small at  $x_0$ . To the left of this point the wind is in equilibrium with the roughness created by the large surface elements. To the right of this point 3 different wind regimes are found. The wind in the sector labeled A remains unchanged although there has been a change in surface roughness. The wind in region C, called the internal boundary layer, is fully adjusted to the new surface roughness; the effects of the previous roughness have been completely lost. Finally, the wind in region B is in a state of transition. The demarcation between the unchanged flow and the transition region is termed the interface, H. In summarizing the literature on the boundary layer, Pasquill (1972) gives the following relationship for the growth of the interface:

$$H \sim x^{0.8} \quad (2-6)$$

The thickness of the internal boundary layer is given as  $H/30$ .

Figure 2 has been drawn to indicate a rough to smooth transition because that is the transition which is most pertinent to V/STOL port siting problems. The opposite transition, while of lesser importance to V/STOL port siting and potential effects on aircraft, is nevertheless an important transition which must be considered in evaluating meteorological measurements. Specifically, at the Lake Union site winds from North through South to Southwest make a rough to smooth transition

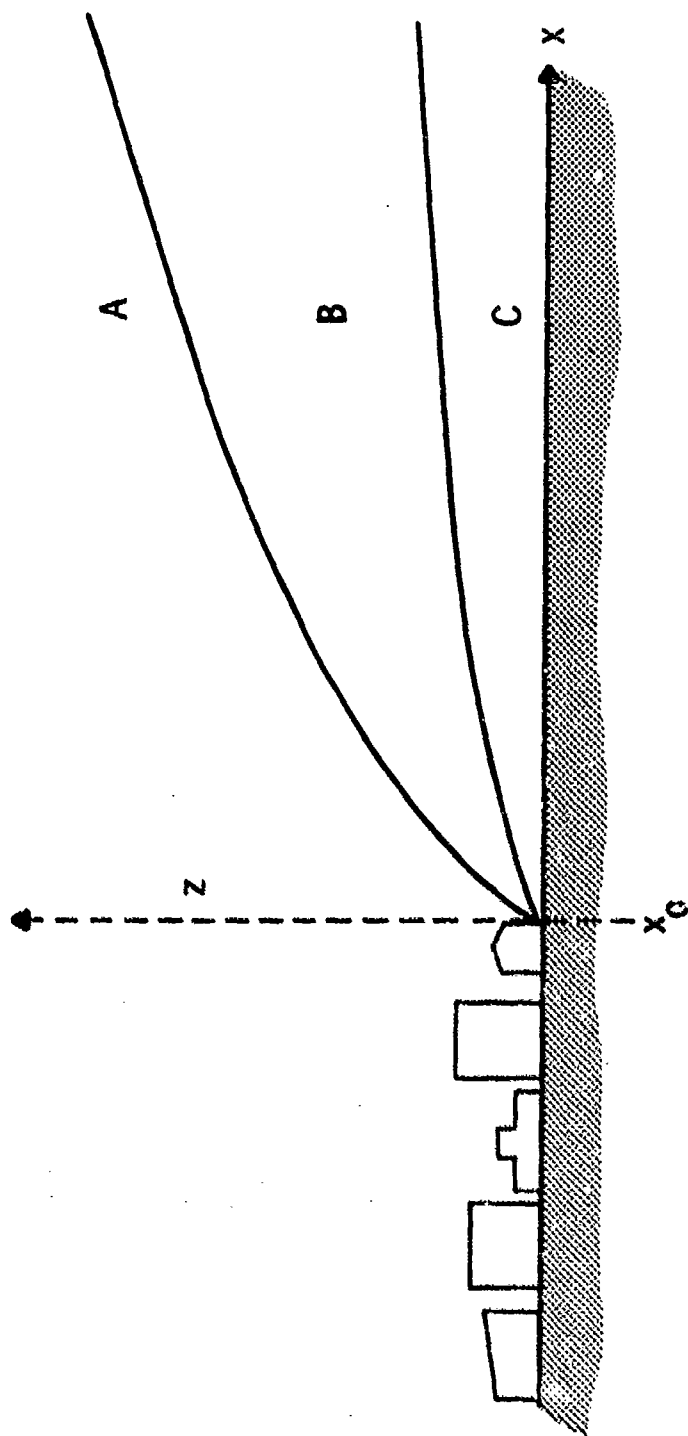

FIGURE 2. Effect of a rough to smooth change in surface roughness on wind profiles. In region A the profile is unchanged. In region B the profile is in a transition state, and in region C the wind profile has fully adjusted to the new surface.

prior to measurement. Winds from the Southwest through Northwest will make a smooth to rough transition. If wind measurements characteristic of the original surface are desired rather than those of the actual underlying surface, then the instruments must be placed well above the internal boundary layer.

The following table (Pasquill, 1972) gives estimates of the interface height as a function of roughness length of the rougher surface, stability and distance from the roughness change.

TABLE 1. ESTIMATED INTERFACE HEIGHT IN METERS AS A FUNCTION OF STABILITY, ROUGHNESS LENGTH AND DISTANCE FROM A CHANGE OF ROUGHNESS

Stability	Roughness Length (m)	Downwind Distance	
		100 m (300 ft)	1000 m (3000 ft)
Stable	0.03	4	18
	1.00	7	28
Neutral	0.03	10	74
	1.00	23	130
Unstable	0.03	22	230
	1.00	44	370

The values for a roughness length of 0.03 m might be applicable to flow across Lake Union prior to reaching the measurement site, and those for a 1 m roughness length are appropriate for wind from other directions. These values are supplied only to indicate the typical magnitudes of the interface height under the simple conditions used in the illustration. The actual conditions at Lake Union are considerably more complex. In addition to a change of roughness there is a simultaneous change in the thermal characteristics of the surface.

In the same paper Pasquill considered a companion problem to that of the effect of a change of surface roughness. That problem is the identification of the area on the surface which has the dominant influence on the wind measurements at a point. Using a rather simple approach, he estimates that this region of maximum influence is approximately an elliptically shaped area located upwind of the measurement point. The horizontal distance to the center of the area (X) and the magnitudes of the alongwind and crosswind axes (a and b, respectively) of the ellipse are dependent upon the height of measurement (h) and atmospheric stability. The relationship between these parameters is illustrated in Figure 3, and relevant values for the parameters for an instrument at a height of 50 m are given in Table 2. The values in the table indicate that the region of influence approaches the measurement point as the atmospheric stability decreases, as expected from the change of roughness discussion. Again application of actual magnitudes to the survey measurements is questionable. Rather, the hypothesized trends are significant in that they may provide an explanation of the actual observations.

TABLE 2. PARAMETERS DEFINING THE POSITION AND SHAPE OF THE SURFACE AREA HAVING DOMINANT INFLUENCE ON A POINT WIND MEASUREMENT

<u>Stability</u>	<u>Distance From Point To Center Of Area (km)</u>	<u>Alongwind Axis (km)</u>	<u>Crosswind Axis (km)</u>
Stable	15	25	0.1
Neutral	0.9	1.2	0.2
Unstable	0.2	0.3	3.4

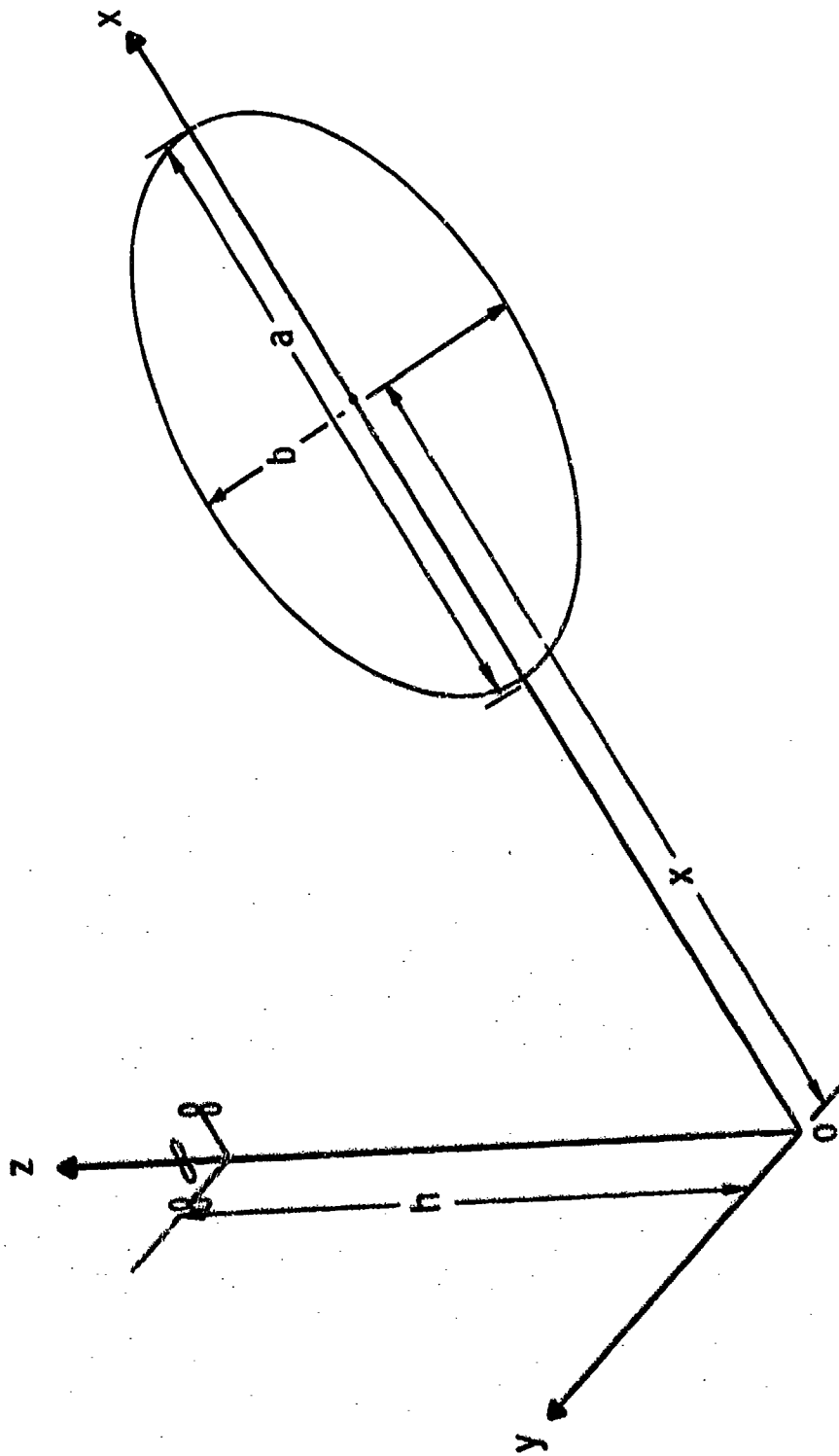

FIGURE 3. Estimated surface area having the dominant influence on the wind at a point above the surface. Typical dimensions for the surface area are given in Table 2.

## BOUNDARY LAYER TURBULENCE

As most of the remainder of this report deals with atmospheric turbulence, it is appropriate to present a short review of the material on turbulence and spectra contained in the Interim Report. Wind flow within the boundary layer is divided into mean and fluctuating parts. Thus,

$$u(t) = \bar{u} + u'(t) \quad (2-7)$$

where  $u(t)$  is the wind speed in the direction of the mean wind at time,  $t$ ,  $\bar{u}$  is the mean wind and  $u'(t)$  is the instantaneous departure from the mean wind at time  $t$ . By convention, the meteorological coordinate system is aligned with the mean wind direction so that the mean crosswind component,  $\bar{v}$ , is zero by definition. Similarly, the mean vertical component of the wind,  $\bar{w}$ , is in general not significantly different from zero. As a result the instantaneous wind vector can be described by 4 quantities,  $\bar{u}$ ,  $u'$ ,  $v'$ , and  $w'$ . The variation of the mean wind speed with height has previously been covered. The following discussion will be concerned with the description of the fluctuations.

The total energy associated with the turbulent fluctuations in the atmosphere is proportional to the sum of the variances of  $u'$ ,  $v'$ , and  $w'$ . It is a portion of this turbulent kinetic energy which is capable of disrupting aircraft operations. Rather than examine the total turbulent kinetic energy, it is common to treat individual components. That is, the variances of  $u'$ ,  $v'$  and  $w'$ , designated  $\sigma_u^2$ ,  $\sigma_v^2$ , and  $\sigma_w^2$  respectively, are treated separately. In addition, it is necessary to treat the covariance between the  $u'$  and  $w'$  fluctuations. The  $\overline{u'v'}$  and  $\overline{v'w'}$  covariances are small compared to  $\overline{u'w'}$  and are assumed to be zero.

Turbulence is generally visualized as consisting of an assortment of eddies covering a wide range of sizes. Since aircraft response is a function of the frequency with which gusts are imposed, it is necessary to describe the distribution of turbulent energy among the various eddy sizes in addition to describing the total turbulent energy content for each component. The mathematical technique used to provide this energy distribution is spectral analysis.

Typical boundary layer turbulence spectra are frequency spectra computed by analysis of a time series of wind data collected at a fixed point in space. The individual component power spectra  $S_Y(n)$ , where  $n$  is frequency, are Fourier transforms of the autocorrelation function of time series. The transformation from the frequency domain in which the turbulence measurements are made to the wave number ( $k = 2\pi n/u$ ) domain for aeronautical applications is made using Taylor's hypothesis as extended. (For detailed discussion of this point see Elderkin et al., 1972.) Under these assumptions the spatial and temporal autocorrelations are identical when the spatial separation in the direction of the mean wind is equal to the product of the time delay and mean wind speed. Equivalence of the autocorrelation functions under these assumptions immediately leads to equivalence of the spectra.

In the atmospheric turbulence literature, spectra most frequently appear multiplied by the frequency or wave number [i.e.,  $nS_Y(n)$  or  $kS_Y(k)$ ], and are displayed on logarithmic plots. These logarithmic spectra integrate into the variance according to

$$\sigma_Y^2 = \int_0^{\omega} nS_Y(n) d(\ln(n)) = \int_0^{\omega} kS_Y(k) d(\ln(k)) \quad (2-8)$$

Presented in this form the spectra have a maximum in the interior of the frequency or wave-number domain which can be used for modeling.

It should be noted at this time that the spectral models most frequently used in aeronautical application, i.e., the Dryden and von Karman spectra, are formally defined over both positive and negative values of frequency or wave number. To arrive at the variance for any component, they must be integrated from  $-\infty$  to  $\infty$ .

The autocorrelation functions from which the spectra are defined deserve some attention at this time. They are even functions by definition. The autocorrelation at zero time lag is equal to 1; for time lags other than zero they have an absolute value less than 1. An integral time scale for the autocorrelation is defined by

$$\tau_Y = \int_0^{\infty} R_Y(t) dt \quad (2-9)$$

where  $\tau_Y$  is the time scale,  $R(t)$  is the autocorrelation function and  $t$  is the time lag. However, if a particular time series is not stationary, i.e., if a trend exists in the data, the integral in Equation (2-9) may not converge and as a result the time scale will not exist.

Length scales,  $L_Y$ , may be defined in the direction of the mean wind if Taylor's hypothesis is assumed.

$$L_Y = \bar{u} \int_0^{\infty} R_Y(t) dt = \bar{u} \tau_Y \quad (2-10)$$

Integral length scales (not necessarily those defined above), when used in conjunction with component variance, serve to fully define the von Karman and Dryden spectra. In these models the integral length scale is used to distribute the turbulent energy between frequencies of wave numbers, i.e., it positions the spectrum in the frequency or wave-number domain.

The shapes of atmospheric spectra, the von Karman spectral model, and the Dryden spectral model were compared in the Interim Report. Reviewing the results, both the atmospheric and von Karman frequency-multiplied spectra are characterized by +1 and -2/3 power law relationships in the low and high frequency regions, respectively. The primary qualitative difference between these spectra is the transition between the two regions. The atmospheric spectra show a more gradual transition. The frequency-multiplied Dryden logarithmic power spectra show the +1 slope in the low frequency region, but do not exhibit the -2/3 slope at high frequencies. Rather, in this region they have a -1 slope. As a result of this deficiency, Dryden spectra are not considered in detail. When observed spectra computed from survey measurements are compared with existing spectral models, the von Karman spectra will be used.

## CHAPTER 3

### SITE DESCRIPTION

Seattle, Washington, the major urban center of the Pacific Northwest, is located on Puget Sound between the Olympic and Cascade Mountain Ranges. The climate of the region is typical of middle-latitude west coast locations, although the air flow and precipitation are modified somewhat by mountains. The air in the region is predominantly maritime, arriving after an extensive trajectory over the Pacific Ocean approximately 100 miles to the west. The Cascade Mountain Range to the east is an effective barrier which protects the region from more severe continental air.

The prevailing winds throughout the year are from the south to southwest with only September showing a prevailing wind from another sector (north). The strongest winds occur during the fall and winter, and are associated with storms passing to the north. Occasionally, a storm will pass to the south of the region resulting in relatively strong northerly winds. On an annual basis, the average wind speed at the Seattle-Tacoma airport is reported as 4.2 m/s (9.4 mph). The maximum monthly average speed is 4.6 m/s (10.4 mph) in January and the minimum 3.6 m/s (8.1 mph) in August.

Storms passing through the region are most vigorous during the fall and winter months. Storms are twice as frequent during the winter months with an average of about 7 frontal passages per month from October through February compared with less than 3 per month during July and August.

Precipitation in the Seattle-Tacoma area is associated with storms moving through the region and areas of low pressure.

Approximately 75 percent of the precipitation, primarily rain, falls between October and March, with the maximum in December. The driest months are July and August. Snowfall is extremely variable from year to year, often melting before a measureable amount can be accumulated. Thunderstorms are not sufficiently numerous to contribute materially to the precipitation total.

The city of Seattle, which has a population of 650,000, is the business and industrial center of the Puget Sound region which has a population of about 2.0 million. As a result, the central business district has developed a skyline which is typical of large cities in that it is dominated by large buildings. During the survey there were approximately 20 buildings within 1/2 mile of the center of the business district which exceeded 20 stories. Of these buildings, most were built in the last 15 years and about half in the last 5 years.

Topographically the central business district is bordered to the southwest by Elliot Bay, to the east by Capitol Hill, and to the north by Queen Anne Hill and Lake Union. This arrangement is shown in Figure 4. The effect of this topography on local climatology is to give prevailing air flow over the city a more southerly orientation than generally experienced in the region. Survey measurement sites were selected to take advantage of this channelization. A location on the shoreline of Lake Union was selected as the primary data collection site. It is labeled Survey Site in Figure 4. A second measurement site was located on a building in the central business district. The black square identified as KIXI in Figure 4 shows this site. Finally, a site at the Seattle-Tacoma Airport about 12 miles south of KIXI was selected for measurements to provide reference data for comparisons between the urban environment and a conventional airport environment.

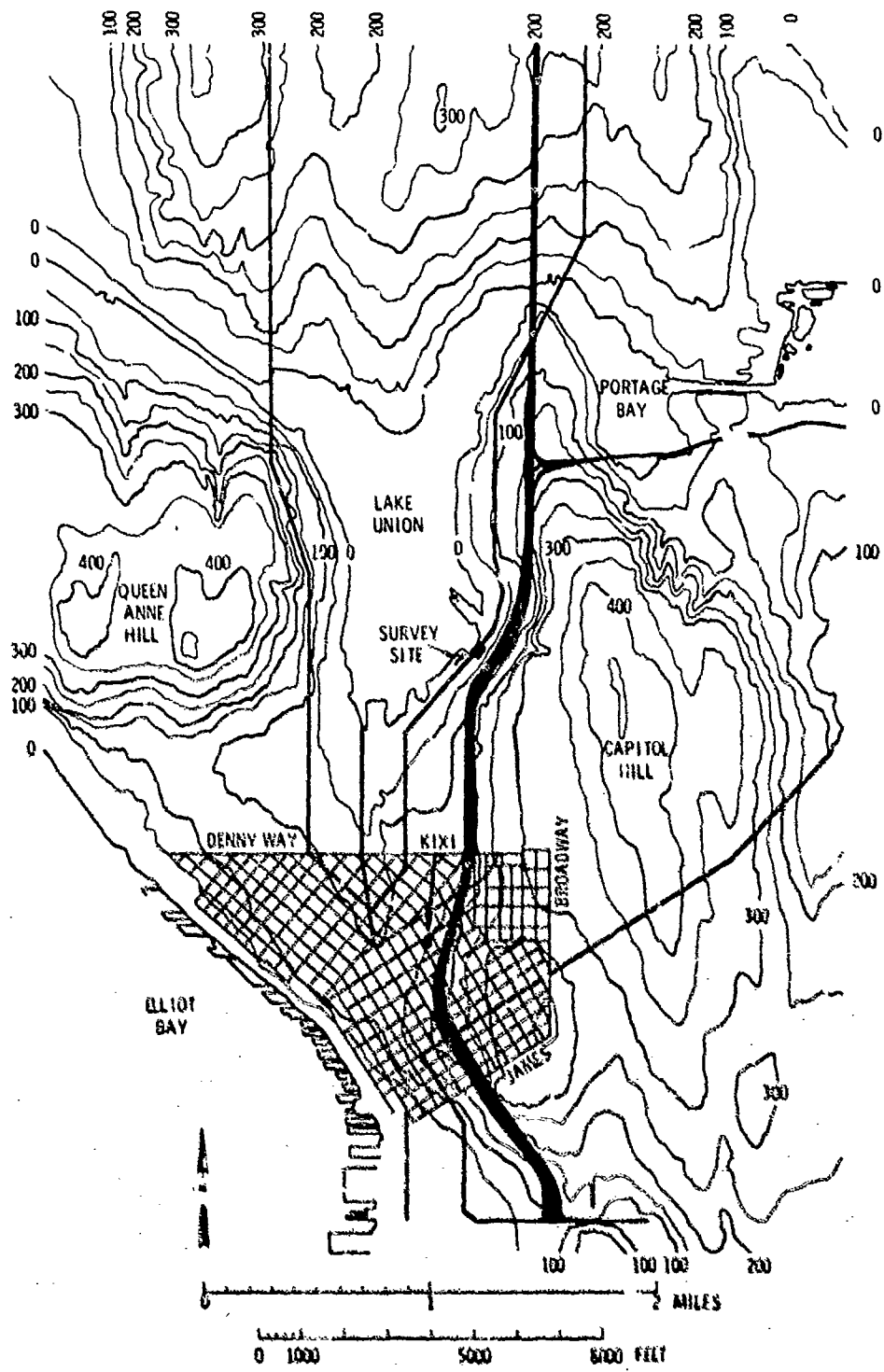

FIGURE 4. Topography of Seattle in the vicinity of the survey measurement sites. Fifty-foot elevation contours are shown.

## LAKE UNION

The Lake Union Site is on the southeast shoreline of Lake Union. It is located approximately 1.4 miles directly north of the center of the business district. Predominantly low buildings (3 - 5 stories) occupy an area between the site and the built-up region. This area extends about 1 mile south from the site.

To the west of the site, Lake Union provides a 0.6 mile smooth surface upwind fetch for air draining off Queen Anne Hill. This hill acted as an effective barrier against westerly winds greater than 5 m/s (11 mph). To the northwest of the site, Lake Union provided a smooth upwind fetch of more than 1 mile and provided a contrast in surface roughness to the fully rough surface of the built-up urban area to the south. To the east, Capitol Hill provided a barrier which prevented significant easterly winds from occurring at the site. The easterly winds which did occur were nighttime drainage winds, generally less than 3 m/s (7 mph). Queen Anne Hill, Capitol Hill, and the hill on the north end of Lake Union are all primarily residential areas.

The Lake Union Site was a relatively flat lot about 183 m (600 ft) in length. The lot's width was 50 m (165 ft) at the narrowest point (southwest end) and 73 m (240 ft) at the widest point (near the northeast end). It sloped to the south so that the southwest end of the site was approximately 0.6 m (2 ft) lower than the northeast end. The average elevation of the site was 2 m (7 ft) above the level of the lake which is nominally 2.7 m (9 ft) above sea level.

Surface roughness was due to low vegetation and a neighboring business. During the measurement period, the site was

covered with grasses and weeds which grew to a height of approximately 1 m (3 ft) during the summer. A boat repair facility, located on the adjoining lot to the south, kept several boats moored along the southern 30 m (100 ft) of the west edge of the property during the survey. The superstructures of these boats extended to approximately 10 m (30 ft). Under prevailing wind conditions these boats were not a significant factor in generation of the turbulence measured at the site.

Figure 5 shows a view of the Lake Union Site and the upwind fetch to the northwest. The site itself is the grass covered field at the bottom of the picture. It is felt that the Lake Union Site is typical of sites which might realistically be considered for ground-level V/STOL ports. The distance to the urban center is sufficiently small to permit high speed commuter transit and yet is sufficiently large that buildings in the urban area would not pose serious threats as obstacles. The buildings close to the site are also felt to be typical of those which might be found near V/STOL port sites.

#### KIXI

The KIXI Site was chosen to provide wind and turbulence measurements which would be representative of conditions which might exist at typical elevated VTOL ports. Measurements were made at the 6.7 and 25 m (22 and 82 ft) levels of the transmitter tower of Radio Station KIXI located on the roof of the Tower 801 Apartments on the northern edge of the built-up area of the Seattle central business district. The base of the tower is 70.4 m (231 ft) above ground level and approximately 110 m (367 ft) above the Lake Union



FIGURE 5. Lake Union survey site and upwind fetch to the northwest.

Site. The location of this site with respect to the Lake Union Site is shown in Figure 4.

The Tower 801 Apartment Building on which the KIXI transmitter tower is located is basically a cylindrical building, 29.2 m (95.8 ft) in diameter. The main building roof is 64.3 m (211 ft) above ground level and 107 m (351 ft) above sea level. It is surrounded by a parapet approximately 0.9 m (3 ft) in height. A machinery room with a diameter of 10 m (31 ft) is located in the center of the roof. The roof of the machinery room is about 6.1 m (20 ft) above the main roof and is surrounded by a 0.9 m (3 ft) parapet. The base of the KIXI tower was located at the center of this roof. The upper portion of the Tower 801 Apartments and the KIXI tower are shown in Figure 6.

To the south, the direction from which the prevailing winds blow, lies the built-up area of the central business district. Figure 7 shows a street map of the region. Included on this figure are the locations of the major buildings. Of the 18 buildings greater than 20 stories shown in the figure, 15 are directly to the south at distances ranging from 350 to 1200 m (1200 - 4000 ft). The vertical dimensions of these buildings are listed in Table 3. (Detailed descriptions of these buildings are available from City of Seattle, Department of Buildings, 503 Seattle Municipal Building, Seattle, WA, 98104.) Several of these buildings extend above the heights of measurement at the KIXI Site. Thus it is expected that they have contributed significantly to the turbulence measured during southerly winds.

To the west and north of the KIXI Site the building tops are considerably lower than the instruments. As a result comparison of turbulence during periods in which winds were from

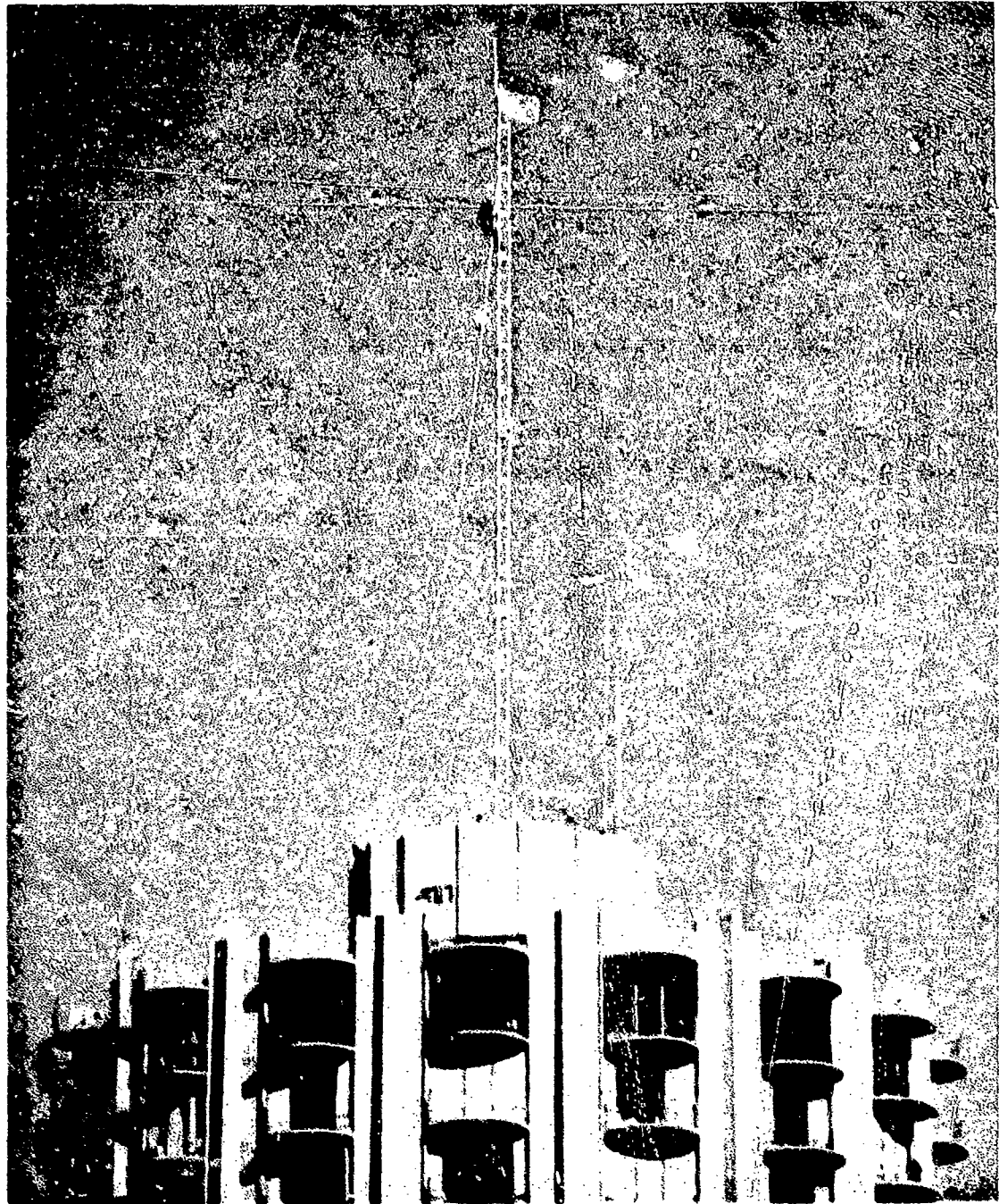

FIGURE 6. View of the Tower 801 Apartments and the KIXI measurement site.

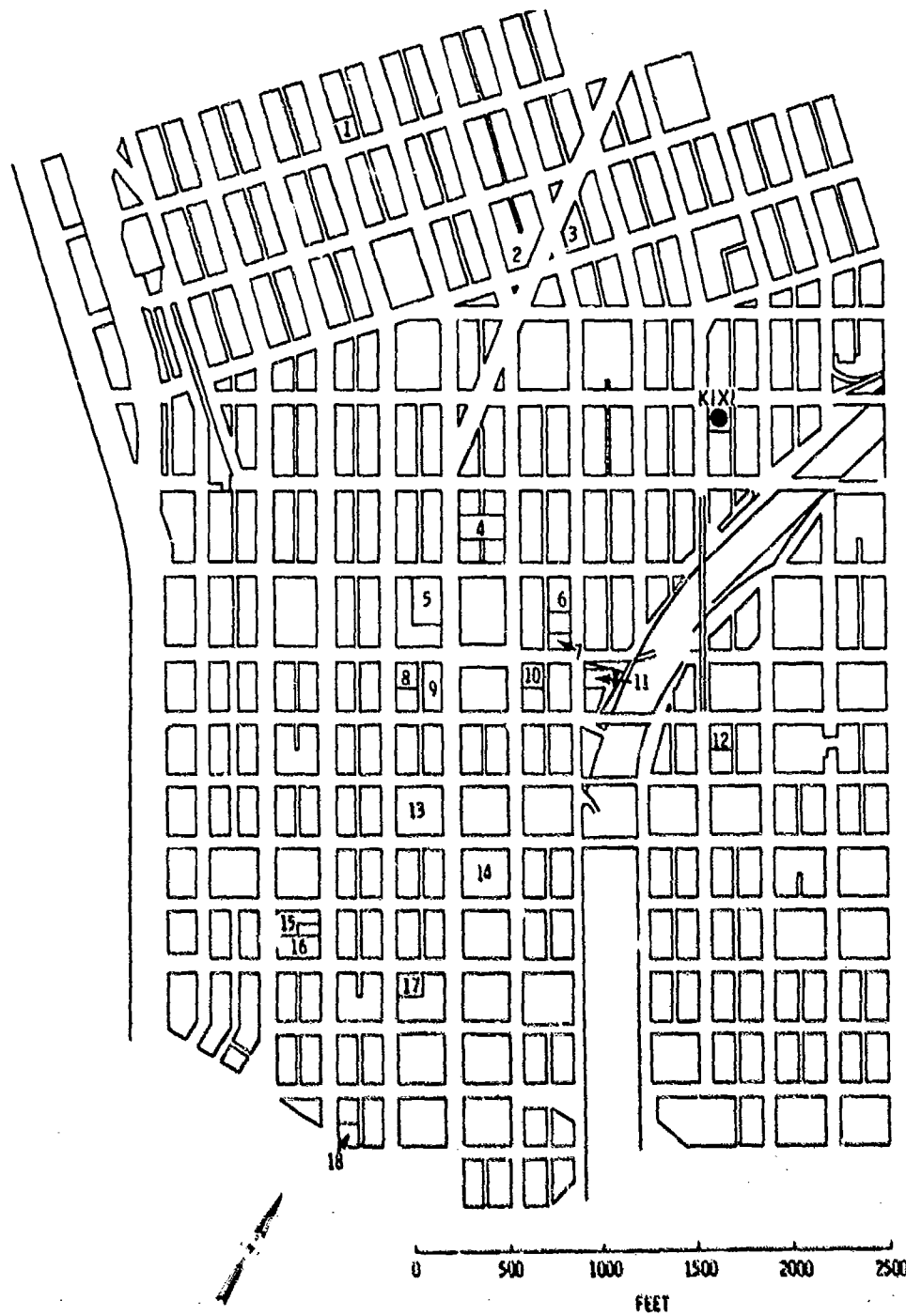

FIGURE 7. Street map of the Seattle central business district showing the locations of the major buildings. The building numbers are keyed to Table 3 which gives the names, vertical dimensions and year of construction of the buildings.

TABLE 3. VERTICAL DIMENSIONS OF MAJOR BUILDINGS OF THE SEATTLE CENTRAL BUSINESS DISTRICT

ID. No.	Building	Stories	Height	Year
			AGL (ft)	
1	Royal Crest	26	230	1973
2	Washington Plaza	40	397	1969
3	Plaza 600	20	270	1969
4	Peoples National Bank	20	266	1971
5	Washington Building	21	289	1960
6	Washington Athletic Club	22	232	1930
7	Seattle Hilton	25	260	1971
8	Seattle Tower	27	272	1929
9	The Financial Center*	37	487	1973
10	IBM Building	23	272	1963
11	Park Place	21	310	1959
12	Royal Manor	21	181	1971
13	Seattle First National Bank	50	609	1969
14	Bank of California	42	536	1973
15	Exchange Building	23	275	1929
16	Norton Building	21	310	1959
17	Pacific Building	22	298	1969
18	Smith Tower	42	500	1914

\*The Financial Center did not reach sufficient height during the survey to be a significant factor.

these directions with turbulence during southerly winds provides a direct estimate of the effects of the complex of large buildings in the center of the business district. The lower buildings on the rising terrain to the east provided an intermediate surface roughness condition for the generation of turbulence. However, the lack of strong easterly winds limited

the usefulness of this condition. Views of the upwind surface conditions are shown for winds from the south in Figure 8, while those for northerly winds are shown in Figure 9.

#### SEA-TAC

To provide concurrent measurements at a conventional airport, a survey site was established 450 m (1500 ft) west of the parallel runways on flat terrain near the south end of the Seattle-Tacoma Airport. The flat terrain extends more than 1.5 km in the sector from NNE through SSE except for a small mound about 3 m (10 ft) high which parallels the runways about 150 m (480 ft) east of the site. Winds coming from this sector should be typical of those experienced by landing aircraft when the wind is aligned with the runway. To the north of the site a small rise is covered with trees extending to about 8 m (26 ft). Beyond this rise the terrain drops rather abruptly, 15 - 20 m, thus the terrain to the north is relatively rough. Finally, in the sector from SSE through WNW the terrain is flat for approximately 300 m (100 ft) prior to dropping smoothly to a highway about 500 m (1600 ft) from the site. The drop is approximately 15 m (50 ft). The SEA-TAC measurement site is shown in Figure 10.

On a somewhat larger scale the airport is located atop a 110 m (360 ft) ridge separating Puget Sound and the Green River Valley. In the vicinity of the airport this ridge is approximately 8 km (5 miles) wide.

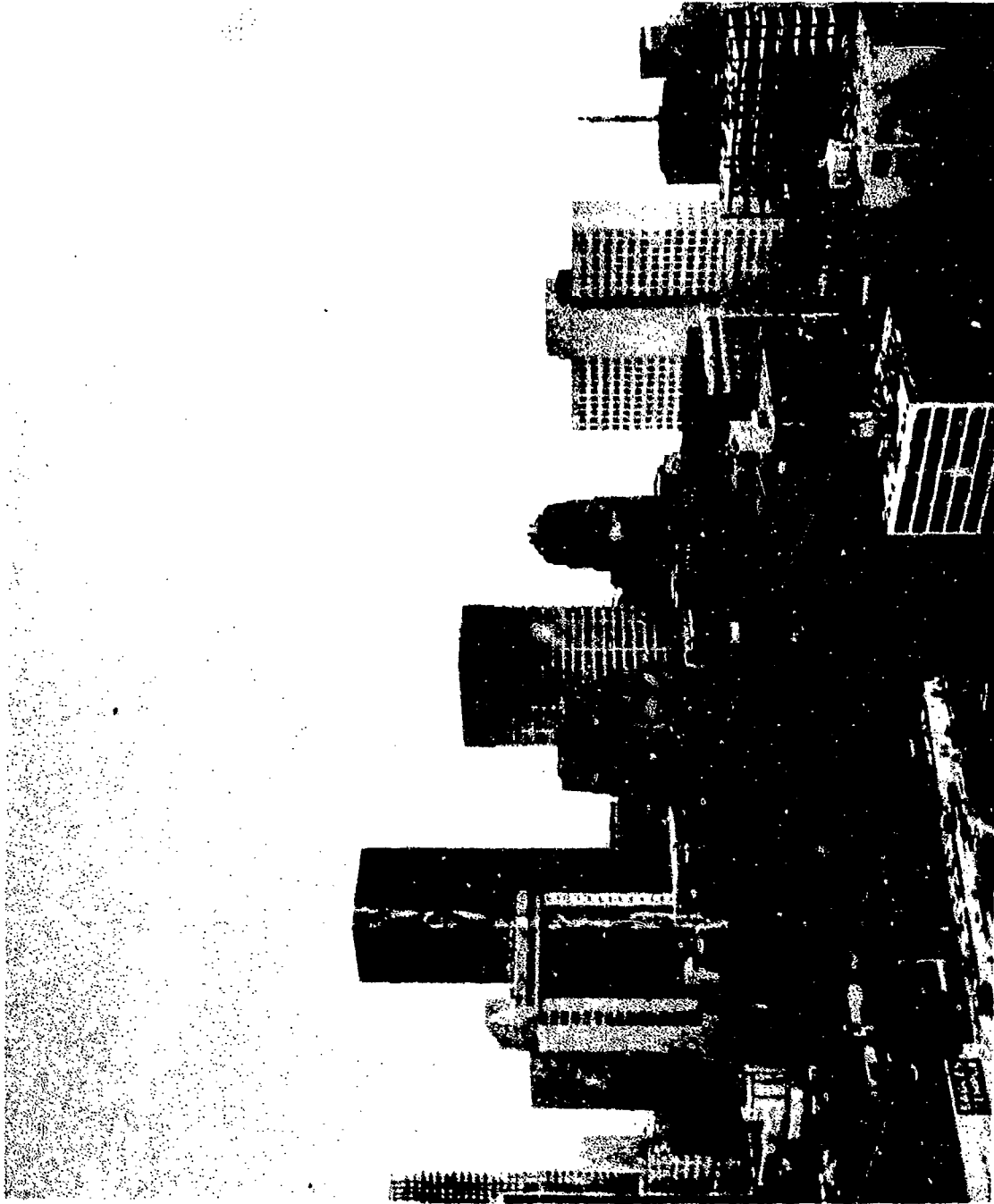

FIGURE 8. View of the central business district to the south of the KIXI site. The photograph was taken from the KIXI site.



FIGURE 9. View of the urban area to the north of the KIXI site. The photograph was taken from the KIXI site.

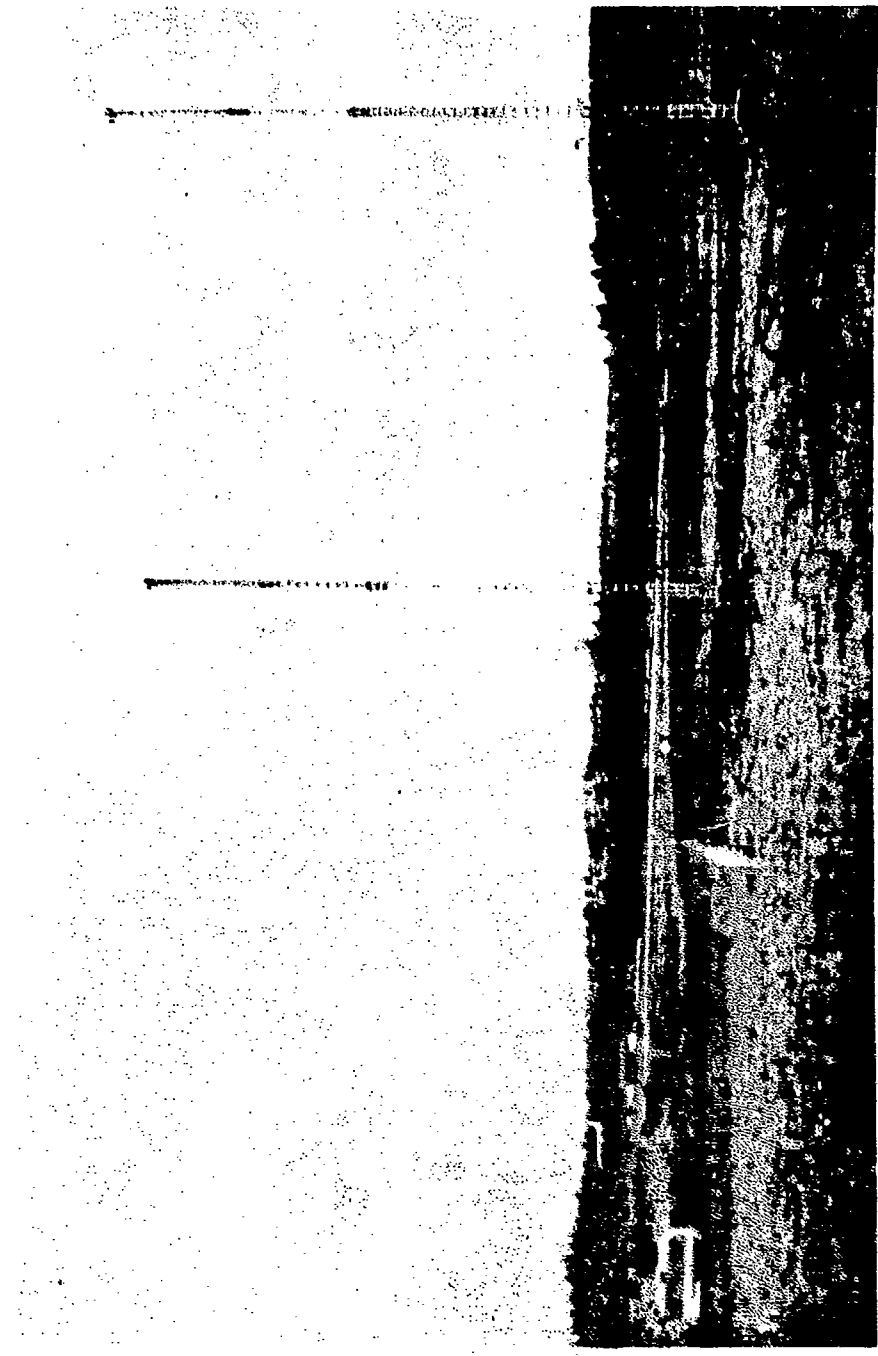

FIGURE 10. View of the SEA-TAC measurement site, looking southeast.

## CHAPTER 4

### SURVEY INSTRUMENTATION

Having completed the description of the survey sites and having reviewed basic boundary layer theory, the remaining topic to be covered prior to discussion of the data analysis and results is the survey instrumentation. The instrument system used in the survey is an extension and modification of the system used by Elderkin et al. (1971, 1972) in "Take-Off and Landing Critical Atmospheric Turbulence" (TOLCAT) research conducted for the United States Air Force. To this basic system has been added instrumentation purchased by the FAA and Battelle-owned instrumentation. Each of the instruments in the system, the towers used to support the instrumentation, the tower arrays, and the positions of the instruments in the arrays are described in this section. In the ensuing discussion the greatest emphasis is given to wind instrumentation, since wind and turbulence are the subjects of most interest. Other instruments are discussed in lesser detail to indicate information available.

#### WIND INSTRUMENTATION

The primary wind instruments used during the survey were three-dimensional Gill anemometers (R. M. Young Company, Model 27002). These instruments have frequently been used as turbulence instruments and their response characteristics and errors are reasonably well understood. To provide a tie to the wind instrumentation currently in use at airports, a cup anemometer and wind vane (Science Associates No. 424), fabricated to the National Weather Service Spec. No. 450.6150, were installed at the lowest measurement level at each site.

Provisions were made for the installation of sonic anemometers at the Lake Union Site although they were not operated successfully.

#### Gill Anemometer

The Gill anemometer consists of three, 23 cm (9 in.) diameter helicoid propellers mounted on orthogonal 40 cm (16 in.) shafts which drive small, low-torque d.c. tachometer generators. The basic components of a single arm of this array are described by Holmes et al. (1964). When in use in this instrument, the arms were attached to a mounting arm and lower housing assembly to give the instrument an overall height of 1.07 m (3.5 ft).

The output of a propeller-generator assembly is linearly related to the component of the wind parallel to the shaft for wind velocities above about 1 m/s. At wind velocities below 1 m/s, internal friction tends to increase the slippage of the propeller and results in a non-linear response as wind velocity is reduced to a threshold velocity of 25 cm/sec (Hicks, 1972). When the actual wind vector is not parallel to the propeller shaft, the output of the generator should be proportional to the product of the magnitude of the vector and the cosine of the angle between the vector and the shaft. The Gill anemometer does not follow this cosine response exactly, as shown in the manufacturer's literature and by Holmes et al., and others. The nature of this error and its correction are described by Drinkow (1972), Horst (1972), and Hicks (1972). Drinkow and Horst both give a single set of correction factors to be applied at all wind speeds while Hicks gives correction factors as a function of wind speed.

In the survey measurements, each arm of the Gill anemometers was fitted with a 9 cm (2.7 in.) shaft extension on the side of the propeller opposite the shaft. These extensions are designed to improve the symmetry of the anemometer response. Hicks (1972) shows that they do, in fact, significantly improve the response characteristic of a component anemometer when the wind vector is nearly perpendicular to the anemometer shaft.

To a reasonable degree of accuracy the propeller anemometer dynamic response to fluctuating wind speeds is defined by a distance constant. The manufacturer's specifications give the distance constant of the Gill anemometer as 0.94 m (3.1 ft), a value which is generally supported by Hicks (1972). Data presented by Hicks and by Camp et al. (1976) show that the distance constant is a function of the angle between the wind vector and the axis of rotation (see Hicks for correct interpretation of the data), increasing as the angle approaches 90 degrees. This distance constant can be interpreted as the amount of air passage (in meters) required for a 62 percent anemometer response to a step change in wind speed. Duchon et al. (1972) and Fichtl and Kumar (1974) present rigorous discussions of the dynamic response of the Gill anemometer which go beyond the usual first-order assumption in which the response is characterized by a distance constant.

The lower housing on the mounting arm contains a small continuous-duty a.c. blower used to maintain positive pressure differential between the interior of the instrument and the atmosphere. This pressure differential is intended to prevent dust and precipitation from fouling the anemometer bearings. The mounting arms on several anemometers were modified to include a small aspirated shield for a temperature sensor. On these, the lower housing contained a second blower used for aspiration. Elderkin et al. (1971) reported that operation

of these blowers resulted in an induced 60 Hz noise signal in their data. This did not appear to create problems in the survey data, perhaps due to the less frequent sampling of the signals.

Custom electronics packages were prepared for use with the Gill anemometers in the survey. These packages were designed to produce signals ranging linearly from -1 to +1 volt as the wind component velocity varied between  $\pm 22.4$  m/s (50 mph) for the horizontal components and  $\pm 11.2$  m/s (25 mph) for the vertical component. The electronics packages were checked at frequent intervals to maintain their calibration.

The experience with the Gill anemometers during the survey was good. Required maintenance was generally limited to replacing a few propellers and the bearings on several arms. No repairs were required on the anemometers at SEA-TAC. At KIXI several propellers were destroyed in a wind with gusts exceeding 25 m/s. During the same wind the upper anemometer was dislodged from its proper orientation, damaging the orientation ring at the base of the mounting arm. At the Lake Union Site propeller damage appeared to be caused primarily by birds and bb's. When propeller damage included the loss of a blade, the bearings supporting the shaft were frequently damaged from the uneven loads imposed upon them. On occasion the loss of a blade resulted ultimately in a bent shaft as well as damaged bearings. Routine inspection of the instruments resulted in the replacement of the bearings on several arms although there was no sign of propeller damage. Only in one instrument did the deterioration of the bearings result in instrument failure, but that failure did not result in a data loss.

### Cup Anemometer and Vane

The cup anemometer and vane were installed at the lowest measurement level at each site to provide a comparison between the sensitive Gill anemometers and wind instruments currently in use at airports. The cup and vane are of much more rugged construction than the Gills and as a result do not respond rapidly to fluctuations in the wind. In addition they have significantly higher response thresholds.

Threshold values were not furnished by the manufacturer of the cup and vane but appeared to be of the order of 1 m/s (2.3 mph) with the cup's threshold slightly lower than the vane's. The signal generated by the cup anemometer was linearly related to wind speed for speeds above 2.5 m/s (5.6 mph). Figure 11 shows a comparison of mean wind speeds measured by the cup and Gill anemometers. At low wind speeds the speed measured by the Gill tends to be larger than that by the cup due to the higher threshold of the cup; at high wind speeds the cup tends toward higher wind speeds than the Gill. This behavior is expected on the basis of the dynamic response of cup anemometers to turbulence and is termed anemometer overrun.

Anemometer overrun is the result of several sources of error in wind speed measurements. Some of the errors are discussed by MacCready (1966), Hyson (1972), Bernstein (1967) and Izumi and Barad (1970). Based on these works it is evident that the errors are more significant for cup anemometers than propeller anemometers and that the errors increase with the level of turbulence.

A signal conditioning package was prepared for the cup anemometers to give a linear output of 0 to 1 volt between

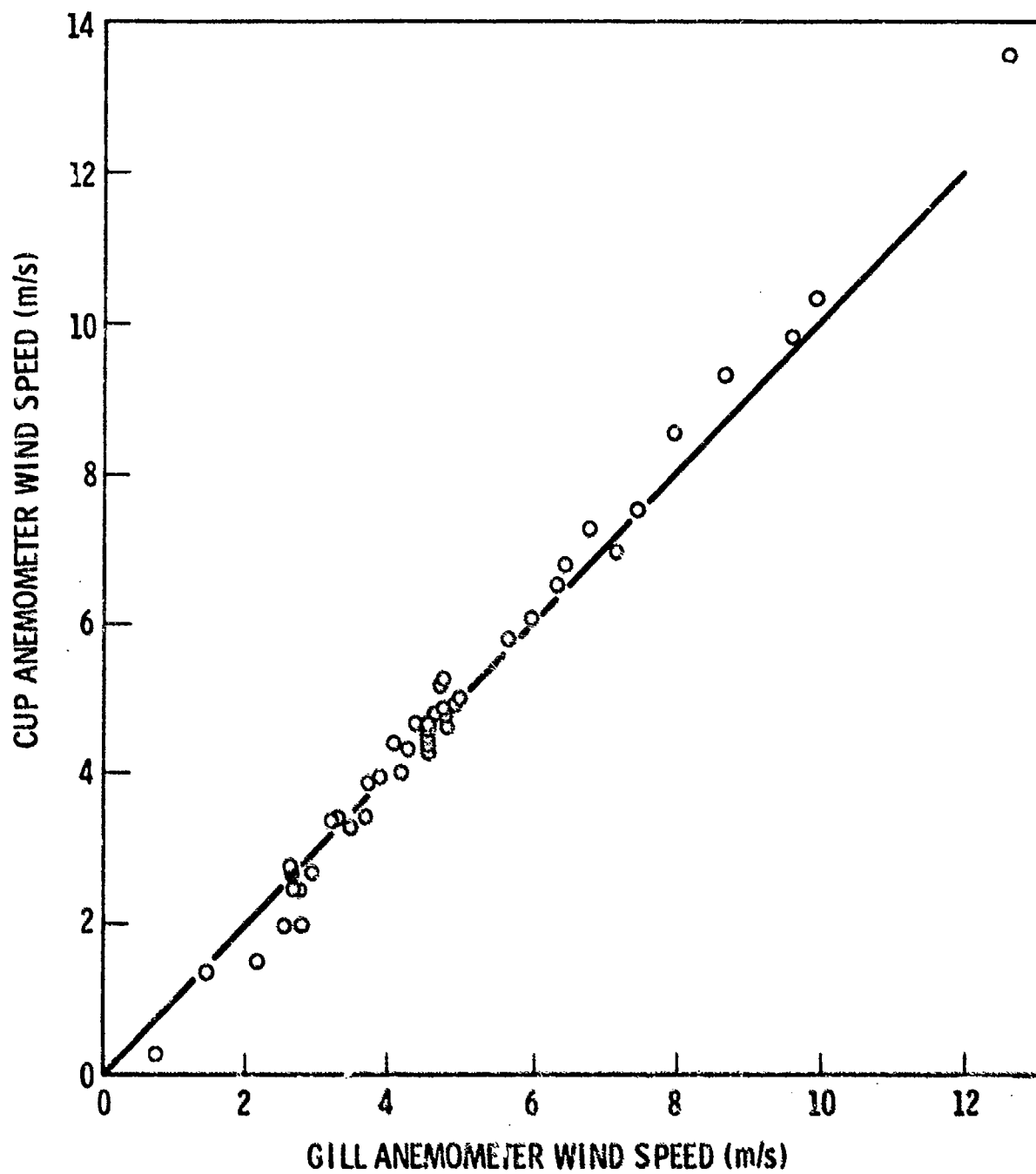

FIGURE 11. Comparison of mean speeds measured by the Gill and cup anemometers.

speeds of 0 and 44.7 m/s (100 mph). The signal generated by the vane varied between  $\pm 1$  volt as the direction varied between north and south. It was possible using the vane signals to determine the angular deviation of the wind from north or south, but it was not possible to determine the sign of the deviation. As a result the recorded signals from the vane are ambiguous. Additional information such as the sign of the signal of the east-west component of the wind from Gill anemometers is needed to resolve this ambiguity. It should be noted that the technique used to generate the signal in the vane was not intended to provide a signal for a recorder but rather it was designed for an indicator.

The cup anemometers and vanes performed well during the survey.

#### Sonic Anemometers

The instrument array at Lake Union included provisions for the installation of sonic anemometers. However, efforts to operate these anemometers in the array were unsuccessful. On several occasions sonics which had been operated successfully at Hanford failed to operate at the Lake Union Site. In each case the anemometers were operated successfully on return to Hanford without repair. It is felt that the noisy signals which made the anemometers unusable at Lake Union were caused by electromagnetic fields in the urban area.

#### TEMPERATURE INSTRUMENTATION

Temperature measurements were made at each level at the three survey sites using bead thermistors (YSI Composite 44018) mounted in aspirated shields attached to the Gill anemometer mounting arms. These thermistors have nominal time constants

of 10 sec in still air and 1 sec in well-stirred oil. In the free atmosphere with a wind speed of 2-3 m/s, the average time constant for 4 sensors was experimentally determined to be about 5 sec with a range of 4.7 to 5.6 sec. The time constant of these sensors when mounted in their temperature shields was found to be considerably longer.

The temperature system electronics packages were designed to provide a temperature resolution to  $1/36^{\circ}\text{C}$ . The system calibrations showed that for large temperature changes the output signal changed by  $36 \text{ mV}/^{\circ}\text{C}$  as designed. However, repeated calibrations and initial data analysis showed the system to be electronically unstable. As a result, temperatures could not be determined with sufficient accuracy for use in either heat flux or profile measurements.

#### SUPPORTING METEOROLOGICAL MEASUREMENTS

Supporting meteorological measurements were made at Lake Union to provide the type data that might typically be available in climatological records. These measurements included temperature, pressure, relative humidity, precipitation, solar radiation, and visibility. A ceilometer was installed but did not provide any usable data.

Temperature, pressure and relative humidity measurements were made using a meteorograph (WeatherMeasure Corporation M701) installed in a standard instrument shelter near the north end of the site. The temperature and pressure measurements recorded by the instrument compare favorably with independent measurements. The recorded relative humidities, however, do not agree with values determined using a sling psychrometer. The differences between the recorded and actual values were consistent so that a calibration curve could be used to correct the recorded

values. The accuracy of the corrected values is approximately  $\pm 2$  or 3 percent in the range 30 - 80 percent relative humidity.

Precipitation measurements were made using a heated, tipping-bucket rain gage (WeatherMeasure Corporation P511E) mounted on the roof of the instrument shelter. Signals from the gage were relayed to a remote event recorder (not a WeatherMeasure product). The rain gage worked properly throughout the measurement period.

Two pyranometers (Epply Models 8-48 and 8-48A) were installed on a 10 m mast near the instrument shelter. The two solarimeters had protective domes with different energy transmission characteristics, one (8-48A) was quartz and the other (8-48) was pyrex glass. Signals from these instruments were recorded alternately for 30 sec intervals on a single analog strip chart.

A National Bureau of Standards type transmissometer, received on loan from the U.S. Air Force, was installed at the site. Due to space limitations and the necessity to have a clear path between the transmitter and receiver, the base line was reduced to 122 m (400 ft).

The instruments for the supporting meteorological measurements were scheduled for routine servicing on a weekly basis. The servicing included cleaning of the devices as well as changing strip charts. More frequent servicing was generally needed, however, since the strip chart recorders tended to be unreliable. As a result there are significant gaps in the precipitation, solar radiation, and visibility data.

The data from supporting meteorological measurements have in general not been reduced to usable format.

#### INSTRUMENT ARRAYS

The wind instruments at Lake Union were mounted in a three-dimensional array using 8 towers arranged in two lines. The relative positioning of the towers is shown in Figure 12. Orientation of the longer line of towers was approximately 034 - 214 °T, and the shorter line was perpendicular to the long line. Open-lattice work, crank-up towers with a triangular cross-section were used. Towers 3, 6 and 7 were 61 m (200 ft) towers which were extended to approximately 50 m (164 ft) in height. The remaining towers were 30 m (100 ft) towers extended to about 25 m (80 ft). The lowest sections were 0.61 and 0.47 m (2.0 and 1.5 ft) on a side for the 61 and 30 m towers, respectively. Dimensions of the upper sections decreased progressively.

Gill anemometers, modified to include temperature sensors were installed at 4 levels on the profile tower (tower 7). Nominally the levels of measurement were 7, 13, 25 and 48 m. In addition, the cup anemometer and wind vane were installed at the 7 m level. To reduce the tower effects on the wind and turbulence measurements, the instruments were mounted on instrument booms extending 1.5 m from the tower. Unmodified Gill anemometers were mounted on 1.5 m instrument booms at the 25 and 48 m levels of towers 3 and 6. Finally, unmodified Gill anemometers were mounted at the top of the remaining towers.

The location of each of the towers and instruments relative to the intersection of the tower lines are given in Table 4. In the table all distances are given in meters along the lines of towers, with x positive to the NE (034°) and y positive

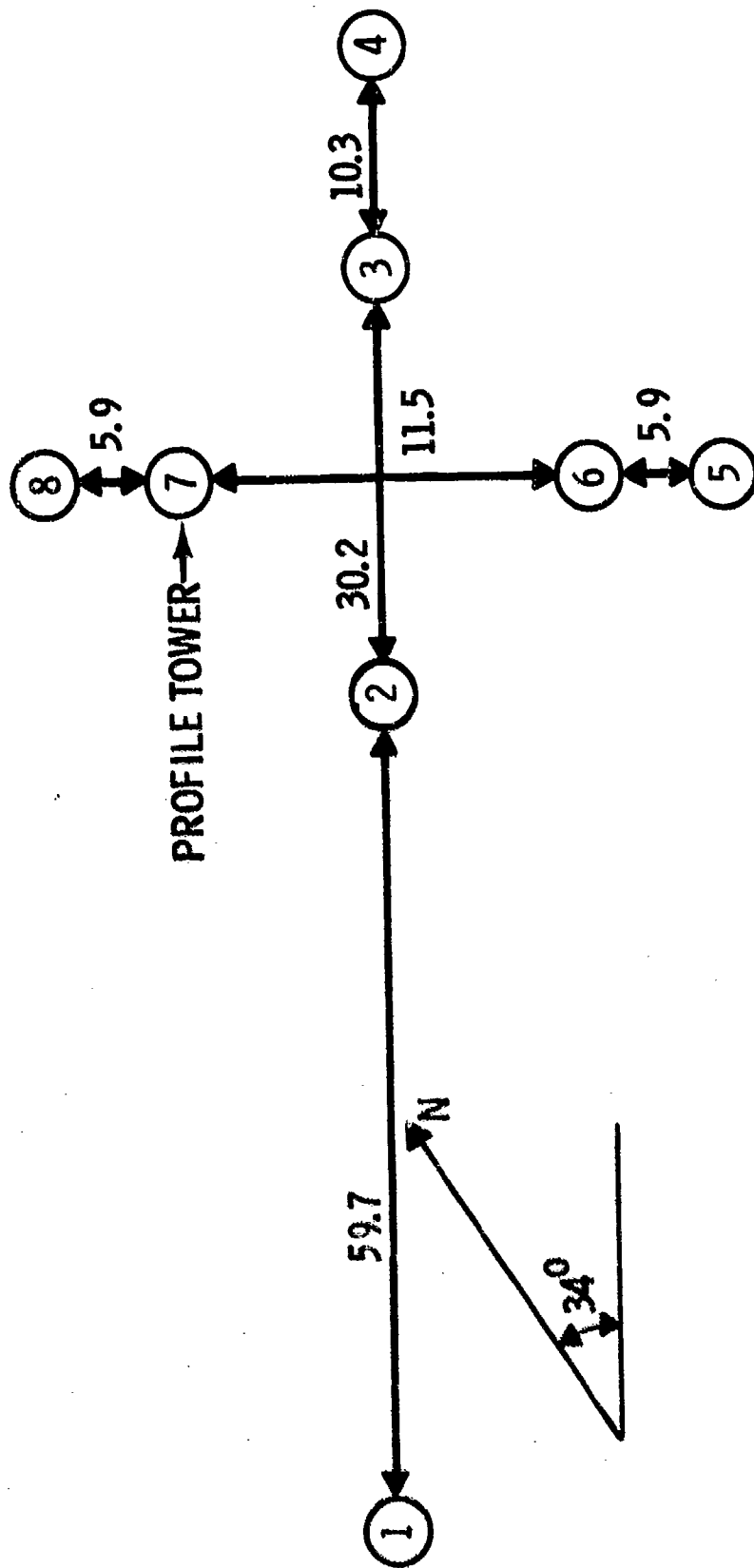

PROFILE TOWER →

FIGURE 12. Relative positions of the towers at the Lake Union Site. Distances between towers in meters.

TABLE 4. POSITION OF TOWERS AND INSTRUMENTS AT THE SURVEY SITES

Site	Tower	Instrument	Position (m)		
			X	Y	Z
Lake Union	1	Base	-79.9	0	- 0.7
		Gill	-79.9	0	25.0
	2	Base	-20.2	0	+ 0.1
		Gill	-20.2	0	25.2
	3	Base	10.0	0	+ 0.1
		Gill	8.8	+ 1.0	25.2
		Gill	8.8	+ 1.0	48.1
	4	Base	20.3	0	- 0.1
		Gill	20.3	0	25.1
	5	Base	0	-11.6	0
		Gill	0	-11.6	25.0
	6	Base	0	- 5.7	0
		Gill	- 1.5	- 5.3	25.3
		Gill	- 1.5	- 5.3	48.0
	7	Base	0	+ 5.8	+ 0.2
		Gill, Temp	- 0.8	+ 4.5	6.9
		Cup	- 0.4	+ 3.8	6.9
		Vane	- 1.0	+ 5.2	6.9
		Gill, Temp	- 0.8	+ 4.5	12.6*
		Gill, Temp	- 0.8	+ 4.5	24.8
		Gill, Temp	- 0.8	+ 4.5	48.2
8	Base	0	+11.7	+ 0.1	
	Gill	0	+11.7	24.8	
SEA-TAC	1	Base	0	0	0
		Gill, Temp	- 1.5	0	7.1
		Cup	- 0.5	- 0.8	7.1
		Vane	- 1.5	+ 0.8	7.1
		Gill, Temp	0	0	27.5
	2	Base	0	-21.3	+ 0.2
Gill	0	-21.3	27.6		
KIXI		Base	0	0	0
		Gill, Temp	- 1.1	+ 1.1	6.7
		Cup	- 0.5	+ 1.6	6.7
		Vane	- 1.6	+ 0.5	6.7
		Gill, Temp	- 1.1	+ 1.1	25.0

\*17.1 prior to August 22, 1973.

toward the NW ( $326^\circ$ ). The reference plane for the vertical measurements passed through the bases of towers 5 and 6 and was approximately 2.0 m above the level of Lake Union. For the Gill anemometers, the position given is the position of the intersection of the u, v, and w component arms.

All Gill anemometers were oriented with the u-component arm to the south and the v arm toward the east. During installation each anemometer was checked using an electrolytic level to ensure that the w arm was vertical. This check was repeated periodically throughout the measurement period.

At KIXI, Gill anemometers were installed at approximately the 7 and 25 m levels of the transmitter tower. This tower is a triangular tower 0.4 m on a side and is of open lattice construction. A cup anemometer and vane were installed at the lower level. All instruments were mounted on 1.5 m instrument booms and oriented in the same direction as those at Lake Union. Exact instrument positions are given in Table 4. The reference position for the instrument locations at KIXI is the base of the tower, 70.4 m above ground (113 m msl), and horizontal distances are positive north and west for x and y, respectively.

Two 30 m towers, similar to those at Lake Union, and separated by 21 m were erected on a line perpendicular to the parallel runways at the Seattle-Tacoma Airport. On the western tower temperature-modified Gill anemometers were installed at 7.1 and 27.5 m. The lower level instruments were mounted on a 1.5 m instrument boom and the upper ones on the top of the tower. A cup anemometer and vane were also installed at the lower level. An unmodified Gill anemometer was installed on the top of the other tower. Instrument orientation was as

before. The relative position of the towers and instruments are given in Table 4. The x-distance is positive to the north and y positive to the west.

## CHAPTER 5

### DATA COLLECTION AND ANALYSIS

Chapters 3 and 4 have described the physical setting in which the survey measurements were made and the instrumentation used for the measurements, respectively, while Chapter 2 established the framework for the analysis of the data. In this chapter the processing of the information generated by the instruments will be discussed. In the first part of the chapter the signals generated by the wind and temperature instruments will be traced through signal conditioning to their ultimate destinations. Then the discussion will cover the experimental programs and their observational requirements. Finally, the analysis of the survey data will be described.

#### INFORMATION FLOW AT THE SURVEY SITES

The signals generated by the survey instrumentation had three ultimate destinations. These were a display panel, a strip chart recorder, and a magnetic tape recorder. At Lake Union there were two magnetic tape recorders. Figure 13 shows a simplified diagram of the flow of information at the survey sites. A signal conditioning package for each instrument provided the link between the sensor and the display and recording devices. Signals were simultaneously supplied to all devices.

The display panel and strip chart recorders were used primarily to monitor the performance of the instrumentation. Neither provided sufficiently accurate read-out for analysis. It was possible to monitor the signals from the wind and temperature instruments directly on meters on the display panel

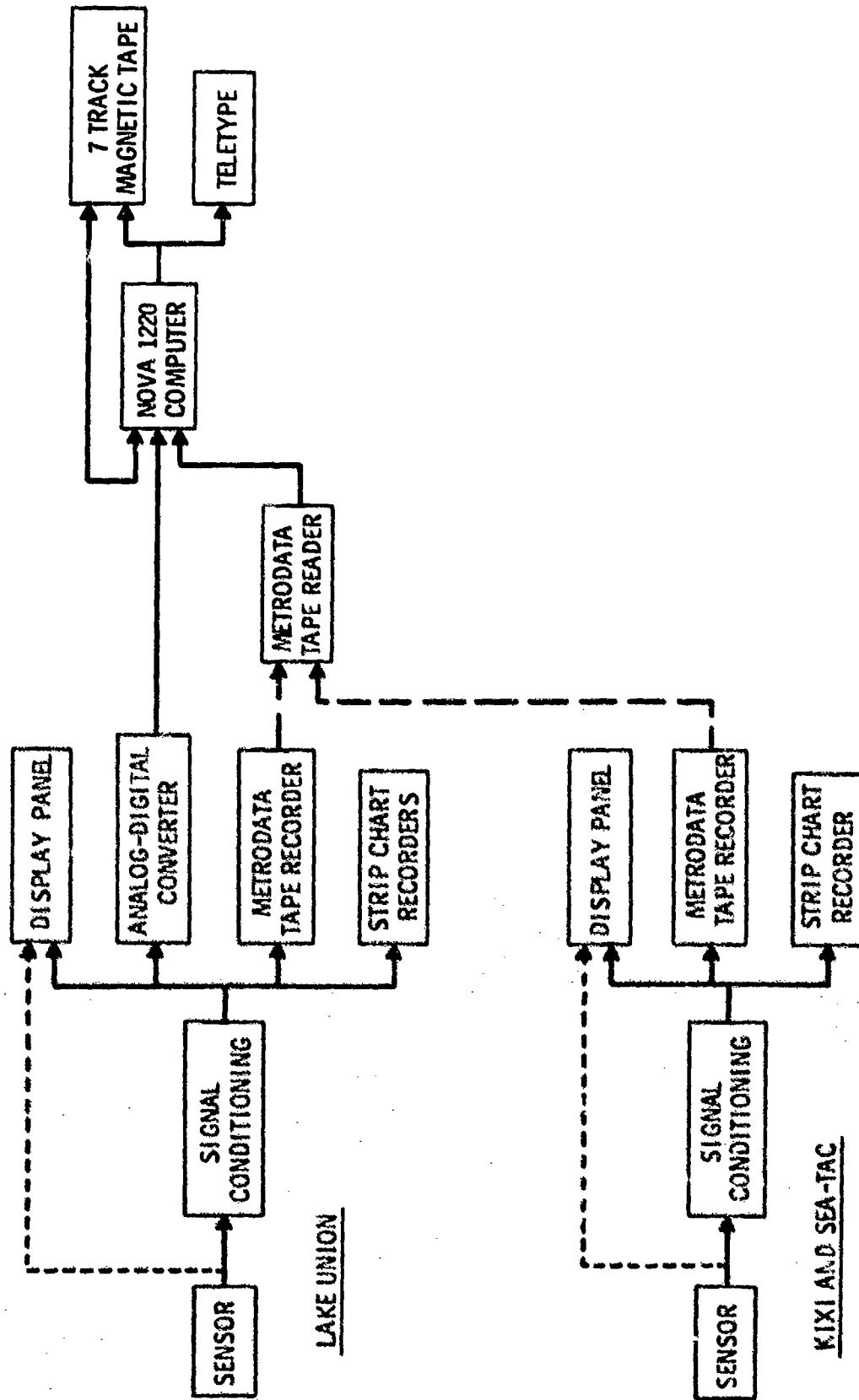

FIGURE 13. Information flow at the survey sites.

by-passing the signal conditioning package. Thus, the display panel was used in identifying the location of malfunctions. All temperature and wind signals were also recorded by multi-point strip chart recorders. The various signals were grouped on the charts in a manner to readily identify malfunctioning instruments. The strip charts provided the only means of estimating the time of an instrument malfunction prior to processing the magnetic tapes. Together, the strip chart records and display panel were used in trouble-shooting in addition to routine monitoring of the instruments.

Two magnetic tape recording systems were used during the survey to collect the primary data for analysis. A Metrodata system was used at all sites. At Lake Union a second system, by-passing the Metrodata equipment, was used during periods of intensive measurements. The understanding of these two systems is sufficiently important that they are discussed here in detail.

#### Metrodata Tape System

A Metrodata tape recorder system was used for routine recording of wind and temperature data at all three survey sites. The tape recorders (Metrodata DL 620A) are digital recorders which record at the rate of 48 signals/sec. Input signals to the recorder are channelized and the channels sampled sequentially. The basic recorder includes 20 input channels with additional channels being available in blocks of 10. All channels are sampled in a given scan. At the end of each scan two additional signals are supplied by the recorder.

The data were recorded on 1/4 in. magnetic tape in special cartridges. Nominally, 1200 ft tapes last 4 hours during continuous data recording, and 1800 ft tapes about 6 hours.

It was found however, that these numbers were about 10 percent overestimated. Two recording options were used; continuous recording and recording for a 5-minute period at 2-hour intervals.

The Metrodata recorders accommodate input signals ranging between  $\pm 1$  volt, and have a 3 digit BCD output providing 2000 digital increments within this range. Thus, the maximum resolution which was available in the recorded data was 1 mV change in the input signal. This corresponds to 2.2 cm/sec for horizontal wind velocity components measured by the Gill anemometers, and 4.5 cm/sec for wind speed measured by the cup. The maximum resolution for the vertical wind velocity was about 1.4 cm/sec.

The magnetic tapes, created by the Metrodata recorder, were not compatible with the UNIVAC 1108 computer used in the data analysis. To create data tapes to be used on this computer, the data were transferred to an industry standard 7-track magnetic tape using a mini-computer (Data General NOVA 1220) at the Lake Union Site and a conventional 7-track tape unit (Potter Instrument Company, MT 36) having read and write capabilities.

During the transfer of the data from Metrodata to Potter tapes, the NOVA performed preliminary data editing and formatting to simplify the data processing required on the UNIVAC 1108. The data were examined for unrecognized characters, incomplete scans, etc. Garbled data were replaced with -999, and incomplete scans were filled similarly. When initial editing was completed, the data from 10 Metrodata recorder scans were written on Potter tape in BCD as a single record. Unused data channels and the preparity and parity characters were dropped

in creation of the Potter tapes. On the average, 5 Metrodata tapes were transcribed on a single Potter tape.

The Metrodata system proved to be the weakest portion of the survey instrumentation. The time and effort required to maintain the tape recorders in an operational status were much greater than had been anticipated. The electronics problems which were encountered are too numerous to list. On the basis of the experience gained in this program, the Metrodata recorders are classified as not sufficiently reliable for continuous, unattended operation.

Aside from electronics malfunctions, problems with the system were encountered in three areas. Only one special character (the preparity character) was available which could be used to determine the position of data words within a scan. Additional special characters, such as, beginning of observation, beginning of scan, and end of observation, would have reduced the cost of data processing and increased the rate of data recovery. The alignment of the tape write heads in each recorder was not matched to the read head in the tape reader. Throughout the first half of the survey it was necessary to adjust the tape reader heads prior to processing each cartridge. This problem was finally overcome by a factory realignment of all tape heads. The final problem of note was the time required for the tape drives to come up to speed. This invariably led to the loss of the first scan or two in each observation.

#### Direct Recording System

The direct recording system at Lake Union by-passed the Metrodata recording system. After signal conditioning, information signals from all the wind and temperature instruments

in the tower array were input to a 64-channel analog-to-digital converter interfaced with the NOVA computer and digitized at a 2 Hz rate. Digitized signals were stored until 10 sec data had accumulated and then written to tape as a single record consisting of 24 bit binary words.

The A-D converter provided 2000 octal increments within the range -1 to +1 volt. This is equivalent to 1024 decimal increments. As a result, the maximum resolutions for wind velocities were 4.4 cm/sec for the Gill horizontal components, 8.7 cm/sec for the cup anemometer, and 2.7 cm/sec for the Gill vertical component.

Data tapes created using the direct recording system were ready for immediate data analysis. There was no requirement for further preliminary processing. The binary words recorded by the direct recording system did not require decoding on the UNIVAC 1108 as did the BCD words on tapes created from the Metrodata system tapes. As a result, the cost of the initial UNIVAC 1108 processing of the direct system tapes was about 50 percent of the cost for the Metrodata system tapes.

#### OBSERVATION PROGRAMS

Collection of needed information on turbulence in urban environments for application to V/STOL aircraft design, certification, flight simulation and operation has been identified as a primary goal of the survey measurement program. It has also been noted that the needed information included both a detailed description of the average conditions and a description of the variation about this average condition. To obtain this information two observation programs were carried out during the survey. The first was an intensive measurement program in which data were recorded continuously for extended

periods of time; the second was a climatological measurement program in which data were collected for 5 minutes every 2 hours. These two programs were arrived at as an optimum compromise between cost and utility of data.

#### Intensive Measurement Program

The intensive measurement program was designed to provide the information needed for the detailed description of turbulence in both time and space. To accomplish this task with acceptable confidence requires the analysis of relatively long data time series. The time series used in analysis of the data collected in this program generally consisted of 4096 points, although in some cases series of 2048 data points were analyzed.

A total of 24 periods ranging from 35 min to 14 hr and 24 min in duration were selected for intensive measurements at Lake Union. In all, more than 92 hour's data were collected in the intensive measurement program at Lake Union. The data for these periods were recorded by the direct recording system.

These data have not all been analyzed. Rather, 37 periods of interest were selected for analysis. Of these periods of interest, 34 contained 4096 data points per signal and the other 3 contained 2048 data points. At the 2 Hz sampling rate of the direct recording system, these series represent approximately 34 and 17 min time histories, respectively. Thus, only about 22 percent of the intensive measurement data collected at Lake Union have been analyzed.

There were 5 periods of intensive measurements at KIXI ranging from 1 to 5 hr in duration and resulting in almost 14

hour's data collection. From these data, 10 periods of interest were selected for analysis. Each period contained 4096 data points (about 31 min at the Metrodata sampling rate of 2.18 Hz). Thus, slightly over 1/3 of the data have been analyzed.

Finally, a single intensive measurement period of 3 hr and 25 min duration was conducted at SEA-TAC. From this observation, 3 periods of interest were selected for analysis. These 3 periods corresponded with periods of intensive measurement data collected at Lake Union and KIXI which were selected for analysis.

#### Climatological Measurement Program

Just as the intensive measurement program was designed to provide the information needed for detailed description of turbulence in an urban area, the climatological measurement program was designed to provide information to describe the climatological variation of the turbulence.

In the climatological measurement program, observations were made for about 5 min every 2 hr at each site. The 5 min observation periods were selected to provide 512 data points for each signal for use in spectral analysis and the observation frequency of 1 per 2 hr was selected so that the Metrodata tapes would last 3 days between changes. Both numbers were the result of compromises between the expense of data collection and analysis and the number of data samples and observations needed for confidence in results of the analysis. Reduction of the number of samples to 256 would have resulted in too low confidence in individual turbulence estimates and increasing it to 1024 for increased confidence would have required that each observation period be extended to almost 10 min. Similarly,

an increase in the frequency of observations to 1 per hr would have required almost daily changes of the Metrodata tapes, while a decrease in the frequency of observations to compensate for longer observation periods would have reduced the total number of observation periods too far to permit quantitative evaluation of the climatological variability of turbulence parameters.

At Lake Union the instruments on the profile tower and the Gill anemometers at the 25 m levels of towers 3 and 6 were included in the climatological measurement program. A total of 52 signals (including the preparity and parity signals) were sampled in each scan of the Metrodata recorder. Each Gill anemometer and temperature signal was sampled twice per scan giving an effective sampling rate of 1.85 Hz. The signals from the cup anemometer and wind vane were sampled once per scan with an effective sampling rate of 0.923 Hz.

At KIXI and SEA-TAC all instruments were sampled once per scan. Since the Metrodata recorder's scan included 22 potential signal inputs in each case, the effective sampling rate for both sites was 2.18 Hz. This is the same sampling rate as in the continuous scanning mode used for the intensive measurements.

The data recovery rates for the climatological wind measurement program were 77 percent for Lake Union and SEA-TAC and 52 percent for KIXI. The Metrodata recorder system problems discussed earlier were the primary cause of lost data. Additional data losses were caused by failures of components in the signal conditioning packages. Only minor data losses were caused by actual malfunctions of the sensors themselves. The data recovery rates listed are based on the number of observation periods for which any usable wind data were

recovered. If the data recovery rates had been based on total recovery of wind data, including spectral data which required 512 consecutive data points, they would have been about the same for Lake Union but much lower for SEA-TAC and KIXI.

#### DATA ANALYSIS

The primary analysis of the survey data was completed on a UNIVAC 1108 computer in three stages. The first two stages of the data processing were required to put data in usable form for the analysis which was performed in the final stage. The three stage processing of data is the same as that used by Elderkin et al. (1971 and 1972) in the TOLCAT program. Data handling routines were altered as necessary, but the changes were primarily in bookkeeping and did not affect the analysis of the data. The first two processing stages were generally completed separately to permit identification of periods of unusable data with a minimum expenditure of funds, although they were combined occasionally. In no case was the final analysis combined with earlier steps.

#### Preparatory Processing

The initial stage of processing was conversion of the data from NOVA to UNIVAC 1108 representation and subsequent conversion of the data from voltages to engineering units such as cm/sec. Prior to processing the data on the UNIVAC 1108 computer, it was necessary to convert the 24 bit NOVA words to 36 bit UNIVAC 1108 words. In the case of data initially recorded by the Metrodata system it was also necessary to convert BCD characters to UNIVAC 1108 field data representation. These conversions were carried out simultaneously. The data were then converted to engineering units, packed 2 per UNIVAC 1108 data word and stored on tape to be used in the next stage

of processing. Samples of the data in each NOVA record were checked following conversion to engineering units and after packing for storage.

The second stage of data processing prepared the data for final analysis and created the final data tape. In this stage, the data were edited for obvious noise spikes and the Gill anemometer data were corrected for noncosine response and rotated into an axis system aligned with the array of towers if desired. Finally, the corrected data were written on the data tape to be used as input to the analysis program.

The editing of the data consisted of examination of consecutive data points to identify large changes in a signal. Depending on the nature of the signal prior to and following the change, one of three types of editing was performed. If determined to be a noise spike an unrealistic data point was changed to a more reasonable value, either an average of the preceding and succeeding data points or to the preceding value according to a predetermined rule. If the change in signal level was not due to a noise spike but rather to a discontinuity in the data, no change was made. The tests used to determine the need for editing and the rules for changing values of suspected noise spikes are detailed by Elderkin et al. (1972) and Powell and Elderkin (1974).

In the course of the analysis of the data from the intensive measurements at Lake Union, the effects of data editing were given a cursory examination. Data from three periods were analyzed twice using different criteria. The first time the data were analyzed the allowable tolerance between successive wind component velocities was 3 m/s. The analysis indicated a significant number of "apparent noise spike" edits in which the suspected values had been replaced. It also indicated that the rms gust velocities for the horizontal wind

were large (more than 2 m/s). The data were reanalyzed using a larger tolerance, 5 m/s. The second analysis showed a large reduction in the number of edits, but only small changes in the results of the analysis. Typically, the mean wind speed and direction were changed less than 10 cm/sec and 1 degree, respectively. Similarly, rms gust velocities were changed less than 10 cm/sec. Thus, the editing is deemed not to have significantly colored the data analysis.

Following editing of the data, the signals from the Gill anemometers were corrected for noncosine response. Each data point was corrected using the angle between the instantaneous wind vector and the propeller axis in an iterative procedure. The correction procedure followed is discussed by Elderkin et al. (1972) and Horst (1972). The more rigorous procedure using correction factors which are related to wind speed as well as the angle between the wind vector and propeller axes (Hicks, 1972) was not used.

The wind data from the intensive measurement program were rotated in the horizontal plane to align the u component with the line of towers. The angle of rotation used was  $-34^\circ$  ( $34^\circ$  clockwise). In this reference system positive u gusts would represent headwinds to an aircraft directed toward the central business district with its longitudinal axis parallel to the line of towers. The v component is then the crosswind component. Wind data from the climatological measurement program were not rotated.

### Analysis

The analysis of the data occurred in the third stage of processing. By this stage unusable data sets had been eliminated and questionable data points in the remaining sets had

been examined and removed as necessary. From each of these data sets, a subset consisting of  $2^p$  data points/signal was selected for analysis. In the case of the intensive measurements,  $p$  was equal to 11 or 12 giving series of 2048 and 4096 data points, respectively. In the case of the climatological measurements,  $p$  was 9 which gave series consisting of 512 samples each. The successive samples in the series to be analyzed from the intensive measurement program always represented consecutive measurements. This was not true for the series from the climatological measurement program.

Frequently, in the first stage of processing the climatological data, records containing 10 sec data would be found to be deficient in some respect. These were discarded. If a sufficient number of good records were found in an observation period to provide 512 samples, data from that period were prepared for analysis. The data from periods not having 512 consecutive samples were only used to determine mean wind speeds and directions and the distribution of gusts. They were not subjected to spectral analysis and therefore did not provide estimates of turbulence time and length scales.

The data from an entire observation period were entered into the computer and time series selected 2 or 3 at a time for analysis. If the series selected for analysis consisted of the signals from the 3 component arms of a Gill anemometer, the initial analysis consisted of computing the mean value of each series and rotating the horizontal component into a reference system in which the  $u$  axis was aligned with the mean wind vector. If, as in the case of the spatial studies, the series were not from a single anemometer, the rotation of the data was skipped. In some cases, the series to be analyzed were generated by taking the difference between the original signals from the same component at two locations. In essence

the series of differences generated in this manner were time series of spatial wind shear.

Having prepared the selected series for analysis, the statistics of the series were computed. These statistics included the first 4 central moments of each series and the joint second moments between series. For the intensive measurement data, joint third moments were computed. Details of these computations are given by Elderkin et al. (1972). Joint third moment computations were not made for the climatological data due to low reliability of such statistics when based on short records. In fact, the joint second moments which were computed for the climatological data are highly questionable statistically.

The data from the intensive measurement program were subjected to exceedance analysis. This analysis included determination of the number of crossings of a given gust magnitude relative to the rms gust magnitude and the ratio of the crossing of each level relative to the crossings of the zero level. Exceedance distributions were computed separately for positive and negative gusts as well as for the combination of positive and negative gusts. A description of this type analysis is given in Appendix A of the Interim Report. The results of the exceedance analysis have not been summarized at this time and are therefore not included in the presentation of results to follow. This type analysis was not performed on the data from the climatological measurement program.

The standardized distributions of the values in each series were determined by dividing individual departures from the mean by the standard deviation. The standardized distributions were then used to compute cumulative distributions for the series. These distributions were prepared for data from both the intensive and climatological measurement programs. They have not

been summarized and do not appear in the discussion of the results.

Each time series from the intensive measurement program was subjected to high-pass filtering to eliminate low frequency variations of the data which would not have been observed in the climatological measurements. These filtered series were then subjected to a repetition of the moment, exceedance and probability analyses described above. The results of the moment analyses of the filtered series were compared with results of analyses of the unfiltered data. In general, the most significant effect was in the reduction of the variance of the v component. The u-variance was reduced somewhat and the w-variance was not changed significantly. The effects of filtering on exceedance and probability analyses have not been evaluated.

Finally, the unfiltered data series were subjected to spectral analysis as appropriate. The initial step in spectral analysis was the removal of mean values and trends in the data. The intensive measurement program data had the best-fitting second-order polynomial trend removed, while the climatological data had only significant linear trends removed. The technique used to determine the polynomials is given by Wylie (1966). Detrending coefficients for all series are available. The detrending used is discussed by Powell (1974).

Following detrending, the ends of the series were tapered to reduce spurious effects caused by the finite length record. This tapering was accomplished using a sine-squared bell-taper described by Elderkin et al. (1971) and was limited to 5 percent of the data at each end of the series. In effect the magnitudes of departures of the wind from the mean were reduced to zero at the beginning and end of each time series. As the

central portion of the time series was approached from either end the magnitudes of the departures were allowed to gradually approach their true values. New variances and covariences were computed for the detrended and tapered series for use in standardization of the spectra.

Spectral analysis was accomplished using the fast Fourier transform technique. The actual computational procedure is discussed by Elderkin et al. (1971); a general discussion can be found in Jenkins and Watts (1968). The series were treated in pairs. For each pair the following were computed; power spectra for each series, the cospectra and quadrature spectra, the coherency and squared coherency, and the phase spectra between the pair. Descriptions of the properties of the various spectra can be found in texts on turbulence and time series analysis (e.g., Lumley and Panofsky, 1964, and Jenkins and Watts, 1968). At this point it is sufficient to note that the power spectra describe the distribution of variance in frequency or wave-number space. These are the only spectra for which the data have been summarized and for which the results will be presented in the following sections.

The individual spectral estimates have been banded together logarithmically to produce 8 banded spectral estimates per frequency decade. This significantly increases the confidence which can be placed in each estimate. When banded in this manner the spectral estimates in a given band are random variables approximately distributed in a  $\chi^2$ -distribution. The number of degrees of freedom of the distribution can be determined by

$$v = 0.578 Tn \quad , \quad (5-1)$$

where  $T$  is the length of the time series in seconds and  $n$  is

the frequency. The degrees of freedom must be an even integer, thus the smallest even integer greater than  $\nu$  found from Equation (5-1) is selected. (See Jenkins and Watts, 1968 for further discussion.)

From the number of degrees of freedom a confidence interval can be estimated for the banded spectral estimates as functions of the length of time series and frequency. Table 5 gives typical values of  $\nu$  for both the intensive and climatological measurements as a function of frequency. In Table 6 the degrees of freedom in Table 5 are translated into factors which, when multiplied by the banded spectral estimates, give the upper and lower limits of the range within which the true spectral value can be expected at a given confidence level.

TABLE 5. APPROXIMATE DEGREES OF FREEDOM OF THE DISTRIBUTION OF BANDED SPECTRAL ESTIMATES FOR DATA FROM THE INTENSIVE AND CLIMATOLOGICAL OBSERVATIONS

$n$ ( $\text{sec}^{-1}$ )	$\nu$	
	Intensive Measurements	Climatological Measurements
1.0	1 184	148
0.5	594	74.0
0.2	237	29.6
0.1	118	14.8
0.05	59.2	7.40
0.02	23.7	2.96
0.01	11.8	1.48
0.005	5.92	-----
0.002	2.37	-----
0.001	1.18	-----

TABLE 6. FACTORS TO DETERMINE THE RANGE IN WHICH TRUE SPECTRAL VALUES CAN BE EXPECTED

v	Confidence Limit					
	50%		90%		99%	
	Lower	Upper	Lower	Upper	Lower	Upper
2	0.29	1.4	0.052	3.0	0.005	5.3
4	0.48	1.4	0.18	2.4	0.052	3.7
6	0.58	1.3	0.27	2.1	0.11	3.1
8	0.63	1.3	0.34	1.9	0.17	2.7
12	0.70	1.2	0.44	1.8	0.26	2.4
16	0.74	1.2	0.50	1.6	0.32	2.1
20	0.77	1.2	0.54	1.6	0.37	2.0
30	0.83	1.2	0.62	1.5	0.46	1.8
60	0.87	1.1	0.72	1.3	0.59	1.5

This table shows that even in the best frequency band significant errors can be expected in the spectral estimates. It also shows that the confidence in the estimates in the lower frequency bands decreases rapidly. To increase the confidence levels in the survey data, the banded spectral estimates from individual intensive measurement tests were geometrically averaged to form composite spectra. Thus the number of degrees of freedom in the composite spectra is significantly increased and the confidence interval correspondingly reduced.

The above discussion assumes instrument response adequate to measure the fluctuations at each given frequency and no aliasing to inflate the spectral estimates within the frequency band. The survey data may be subject to both errors in the high frequency bands, however, these errors tend to be offsetting. At the highest frequencies, 1.0 to 0.5 Hz, the effects of aliasing occasionally appear to have contributed significantly to the spectral estimates. No attempts have been made to correct survey spectra for these errors. Rather the highest frequency bands, where the errors would be most significant, have been discarded.

The use of the fast Fourier transform technique eliminates the need for direct computation of auto-and cross-correlations. (These computations are exceedingly time consuming.) However, the computation of integral time scales (Equation 2-9) requires that these correlations be available. Auto- and cross-correlations were obtained for survey data by taking the inverse Fourier transform of spectral estimates resulting from the fast Fourier analysis of the data. Cross-correlations for both positive and negative time lags between 0 and 250 sec have been computed at 1/2 sec intervals and are available at 1 sec intervals. Autocorrelations for the same intervals are also available.

For the climatological data, correlations were computed to time lags of 125 sec. These correlations were not saved.

The integral time scale, for each data series subjected to spectral analysis, was computed by numerical integration using the trapezoidal rule. The problem of convergence of the integral was treated by comparing each value of the integral during the integration process with the highest previous value. The maximum value attained during the integration was thus chosen as the time scale. This technique gives over-estimates of the time scale, but it eliminates the nonconvergence problem discussed in the Interim Report. In general, the integral achieved its maximum value relatively rapidly, then decreased as the autocorrelation became negative. On occasion, the integral itself became negative.

Integral length scales were computed from integral time scales using Taylor's hypothesis, i.e., a length scale was computed by multiplying the time scale by the mean wind speed. Data on time scales and length scales have been summarized and are discussed at length later in this report.

## CHAPTER 6

### PRELIMINARY RESULTS

This chapter marks the beginning of the discussion of the results of the survey. It deals with a number of loosely related topics which must be covered prior to the discussion of the more detailed results. In order, the topics covered are: the wind climatology; the determination of atmospheric stability; the evaluation of the roughness length at Lake Union; and the effects of the length of observation on wind parameters. Succeeding chapters will cover: the observed wind component power spectra in an urban area; the development of a power spectral model for an urban area; the development of a gust velocity model for an urban area; and the development of length scale models for an urban area. The final chapters in this report cover the spatial aspects of turbulence, including wind shears and the evaluation of the standard airport cup anemometer as a turbulence sensor.

#### WIND CLIMATOLOGY

Examination of the wind climatology of the survey period has several purposes. Among these are: estimation of extent to which the survey measurements are representative of the longer term climatology of the area and evaluation of the differences in mean air flow at the three measurement sites. In addition, this brief climatological examination is needed in order to compare the survey measurements with estimates contained in the Interim Report.

Complete wind roses for observations made during the survey are presented in tabular form in Appendix A. Due to

intermittent failures of instrumentation, the data summarized in these tables do not represent entirely concurrent measurements. The data recovery rates at SEA-TAC and Lake Union were approximately 77 percent, while that at KIXI was just over 50 percent. The total number of possible observations during the survey was 3,000, since observations were made at 2-hour intervals.

Figure 14 presents a comparison of the frequencies of occurrence of wind directions at the lowest level at the three sites with the SEA-TAC climatological distribution contained in "The Climatology of the United States No. 84-45." The climatological distribution was obtained using a wind instrument located on the roof of the airport's administration building. It is suspected that the relatively low frequency of occurrence of SSE winds shown in the distribution is an artifact of the roof-top location rather than a real climatological feature. Rings in the figure represent frequency of occurrence in steps of 4 percent.

Comparison of the distribution of observed wind directions at SEA-TAC and the climatological distribution shows a reasonable degree of similarity with a preponderance of winds from S through SW. On this basis, it is concluded that the wind direction distribution during the survey period is a climatologically representative sample.

The wind direction distribution at Lake Union shows a more north-south orientation than is observed at SEA-TAC. This is an influence of the local terrain and was expected. In fact, this expectation was one of the prime factors leading to the selection of the site. The frequency maximum to the NNW corresponds to flow being channeled to the north of Queen Anne Hill. NNW winds exceeded 5 m/s relatively frequently. The

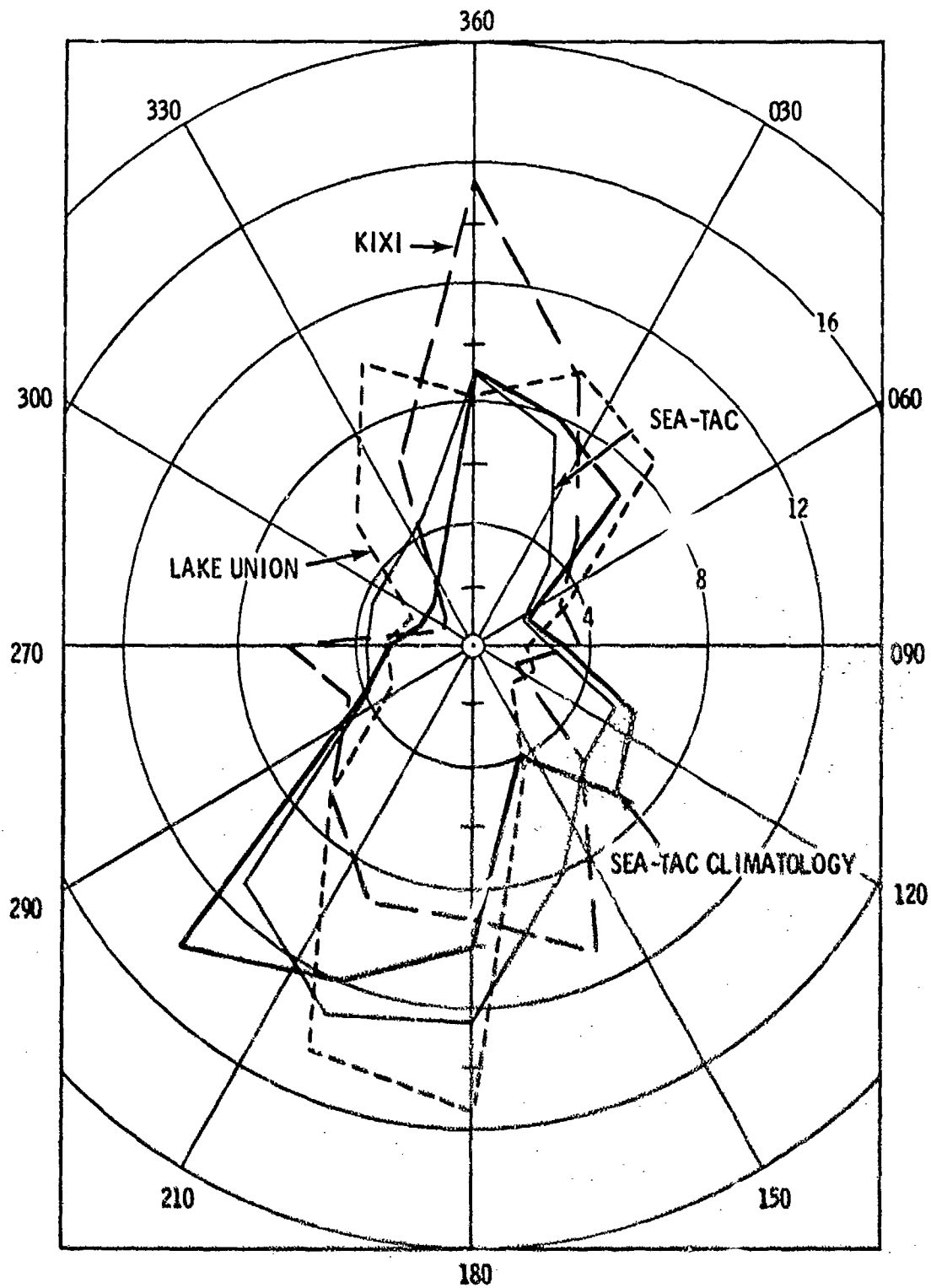

FIGURE 14. Comparison of frequencies of occurrence of wind directions observed during the survey. Height of observation about 7 m at SEA-TAC and Lake Union and 77 m at KIXI.

NE winds on the other hand were primarily associated with a nighttime drainage wind from Capitol Hill. These winds generally did not exceed 5 m/s.

The distribution of wind directions at KIXI can also be attributed to terrain influence. The relatively narrow band of northerly winds results from channelization of the flow between Queen Anne and Capitol Hill. To the SSE of KIXI there is a valley between Capitol Hill and Beacon Hill which accounts for the relatively high frequency of occurrence of winds from that sector.

Wind direction distributions at Lake Union and KIXI both appear to be climatologically representative.

In Figures 15-17 cumulative distributions are shown for the observed wind speeds at each site. In addition in Figure 15 curves are plotted, corresponding to the climatological expectation and the distribution assumed as a basis for turbulence estimates in the Interim Report. All curves in these figures can be reasonably represented by log-normal distributions if calm winds are neglected.

From the start of the survey measurement program through the end of September, 1973, the winds in Seattle were well below average. This is borne out in Figure 15 by comparison of the 7 m climatological curve and the 7.1 m observed data curve. The mean wind speed computed from the survey data for the 7.1 m level was 2.8 m/s (6.2 mph) while the climatologically expected mean wind speed for the same period is 3.7 m/s (8.2 mph). The mean speed computed from the National Weather Service observations at SEA-TAC during the survey period was 3.3 m/s. To conduct the analysis described in the Interim Report, it was necessary to assume a wind speed distribution.

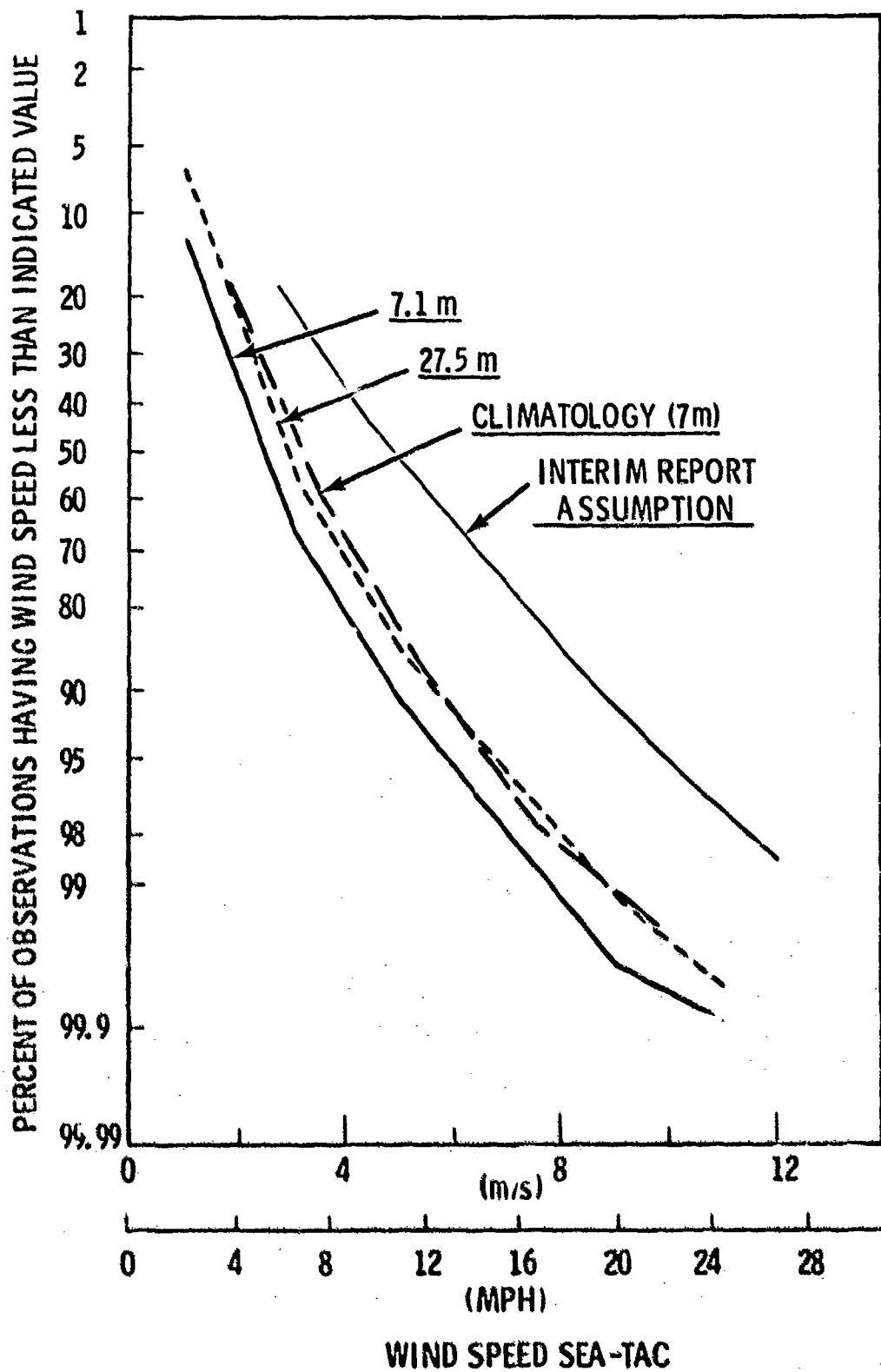

FIGURE 15. Cumulative distributions of observed wind speeds at SEA-TAC, including comparison with climatological expectation and the distribution assumed in the Interim Report.

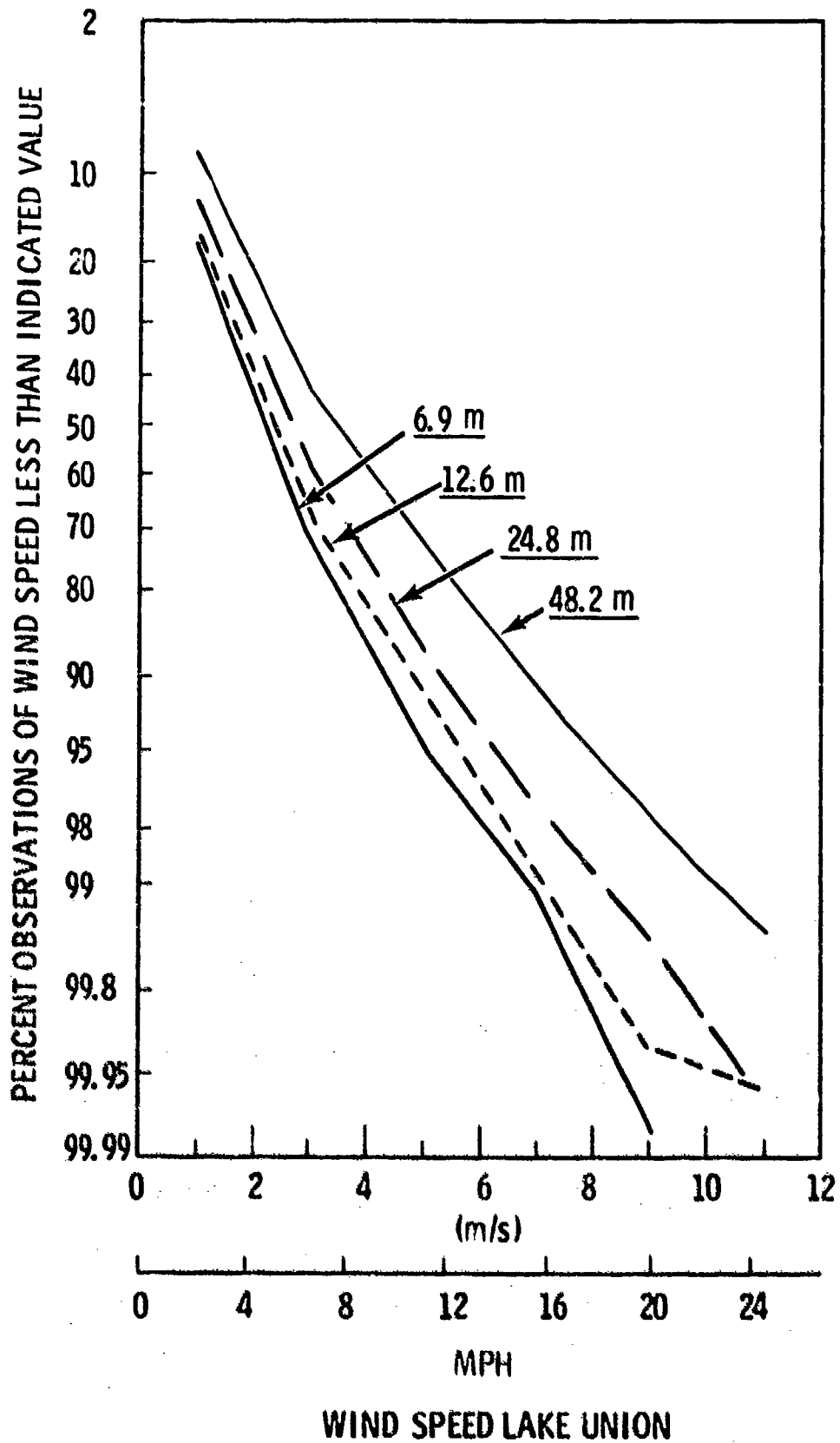

FIGURE 16. Cumulative distributions of observed wind speed. at Lake Union.

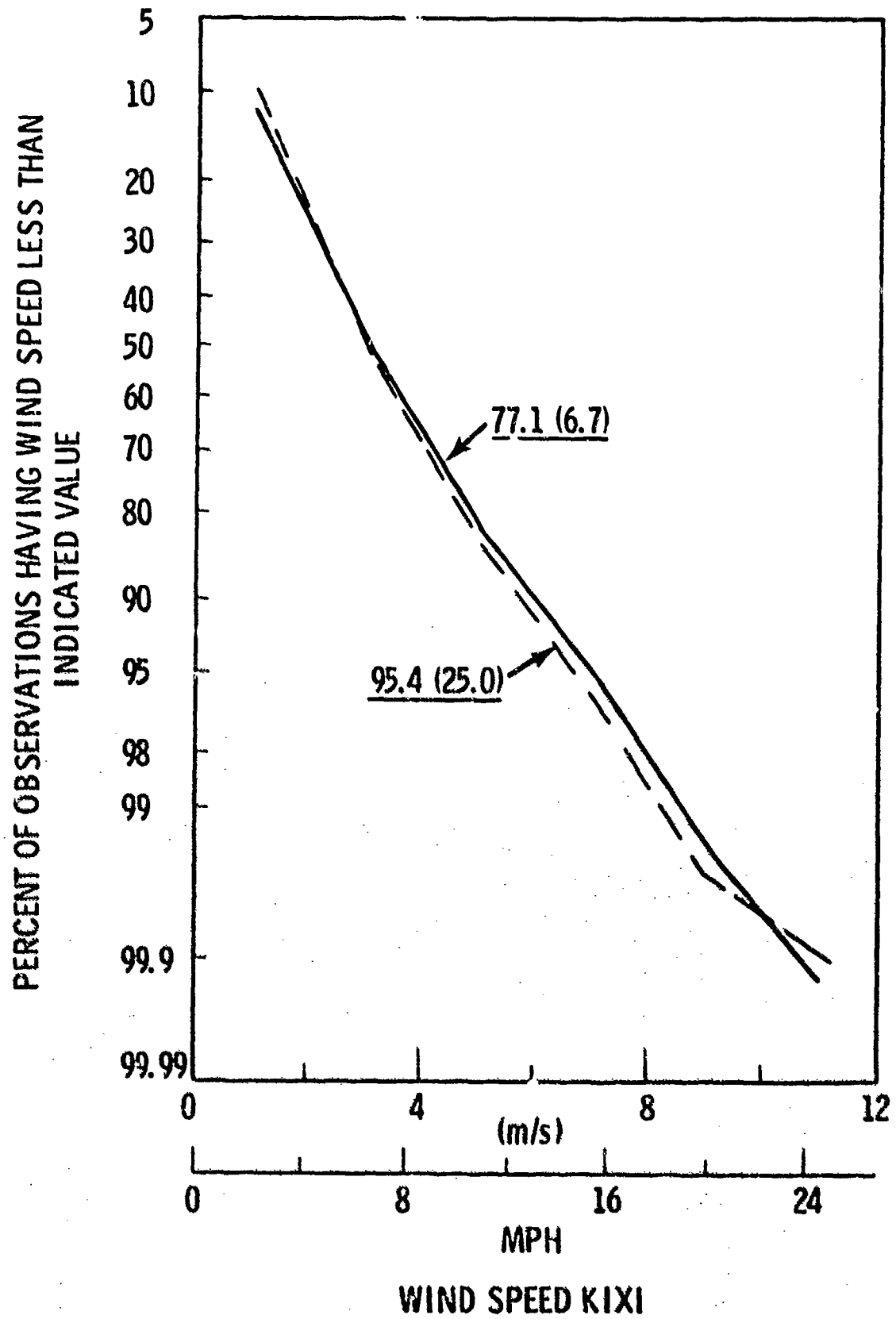

FIGURE 17. Cumulative distributions of observed wind speeds at KIXI.

The distribution selected was obtained from FAA Advisory Circular No. 20-57A and is shown on Figure 15 as the Interim Report assumption. It is readily apparent that there is a significant difference between the observed and assumed distributions. The mean wind speed of the assumed distribution is 5 m/s (11.2 mph) which is almost double the mean of the actual observations. This difference must be considered when comparing wind and turbulence estimates contained in the Interim Report with observed values.

The distribution of observed wind speeds at Lake Union is shown in Figure 16. These distributions have approximately the same shape as those at SEA-TAC with only a slight shift toward lower speeds. The mean speeds at the 6.9 and 24.8 m level were 2.5 m/s (5.5 mph) and 3.0 m/s (6.8 mph), respectively. These values are about 90 percent of the comparable values at SEA-TAC. In the analysis leading to the Interim Report, a ratio between the mean wind speeds in an urban area and those in rural areas was assumed to be 0.8.

The distinctive feature of KIXI wind speed distributions shown in Figure 17 is that the upper level distribution does not show a shift toward higher speeds. Examining the data shows that in moderately strong winds the lower level wind speed is frequently 5 to 10 percent higher than that at the upper level. These same cases are accompanied by a positive rather than zero mean vertical component. This indicates that the lower level instrument is located within the building effect.

The mean wind speeds observed during the survey at KIXI were 3.4 and 3.3 m/s for the lower and upper levels, respectively. This is approximately 20 percent greater than the 7.1 m average wind speed at SEA-TAC. Significant data losses

occurred at KIXI in the last months of the survey which resulted in lower mean wind speeds than would normally be expected. Had they not occurred, the ratio between the KIXI mean speed and SEA-TAC 7.1 speed might have been in the 1.2 to 1.3 range.

#### DETERMINATION OF ATMOSPHERIC STABILITY

In the discussion in Chapter 2 the role of atmospheric stability as a factor influencing wind flow was outlined. The initial analysis of the intensive measurement data from Lake Union showed behavior of the temperature systems which was inconsistent with known characteristics of the sensors. Thus it was necessary to use an alternate indicator of stability. Due to the contrasting thermal properties of the city and Lake Union, it was felt that the use of time-of-day or a simple wind speed-cloudiness technique would be inappropriate. The use of wind measurements was the only alternative which was considered viable.

The potential basis for computation of stability from wind profiles can be seen in Figure 1. If wind measurements at 3 levels can be assumed to be influenced by regions with relatively uniform surface roughness, then the departure of the observed wind profile from a logarithmic form can be used to estimate stability. If a quantitative estimate were desired, an iterative scheme similar to the scheme discussed by Paulson (1970) could be developed. As a practical matter, however, it would be very tenuous to assume that wind measurements at any 3 levels on the Lake Union profile tower would be influenced by a region having homogeneous surface roughness. In addition, normal differences between Gill anemometers would often mask the variations in wind speed profiles due to stability. After cursory evaluation this approach toward estimation of stability

was abandoned. The remaining approach was direct estimation of the nondimensional shear,  $\phi_m$ .

Restating the definition of nondimensional wind shear (Equation 2-5) in terms of finite differences gives:

$$\phi_m = \frac{\kappa(\bar{u}_2 - \bar{u}_1)}{u_* \ln\left(\frac{z_2}{z_1}\right)} \quad (6-1)$$

The term  $\kappa(\bar{u}_2 - \bar{u}_1)/\ln(z_2/z_1)$  represents the wind shear in the neutral (adiabatic) case, and setting  $u_* = (-\overline{u'w'})^{1/2}$  gives an estimate of the shear in the actual, non-neutral (diabatic) atmosphere. Unfortunately, the time required to provide a good estimate of  $-\overline{u'w'}$  is considerably longer than that required for  $\bar{u}$ . As a result, it is not possible to estimate stability on a climatological basis for the survey period. Evaluation of the effects of stability is therefore limited to the extended runs. The levels chosen for stability determination were the 12.6 m and 24.8 m levels. The  $u_*$  used in the stability determinations was the geometric mean value of  $-\overline{u'w'}^{1/2}$  between these levels. The results are interpreted as applicable at the geometric mean height of observations, 17.8 m. Wind parameters which are examined as a function of stability are also the geometric mean of the measured or computed values at these levels.

The use of the geometric mean  $u_*$  rather than  $u_*$  at one level has the net effect of tending to group data in the neutral category, which has arbitrarily been defined as  $0.8 \leq \phi_m \leq 1.25$ , if the individual estimates of  $u_*$  are correct. Values of  $\phi_m$  less than 0.8 were considered to be representative of unstable conditions, and those greater than 1.25 were considered to represent stable conditions. If random errors exist

in the estimates of  $u_*$ , the use of the geometric mean  $u_*$  will tend to reduce spuriously large or small values of  $\phi_m$  which might be caused by those errors.

Values of  $\phi_m$  computed for the 37 extended test periods at Lake Union ranged from a stable 2.62 to a rather unstable 0.34. Table 7 gives the relationship between  $\phi_m$  and the nondimensional height ( $z/L$ ) in this range based on relationships given by Businger et al. (1971). Interestingly both stability extremes were during northerly wind conditions. As expected, the bulk of the values (20) of  $\phi_m$  fall in the neutral range. Of the remaining tests, 4 were stable and 13 unstable.

TABLE 7. RELATIONSHIP BETWEEN NONDIMENSIONAL WIND SHEAR AND NONDIMENSIONAL HEIGHT

$\phi_m$	$z/L$
0.4	-2.5
0.6	-0.48
0.8	-0.096
1.0	0
1.2	0.043
1.4	0.085
1.6	0.13
1.8	0.17
2.0	0.21
2.4	0.30

To evaluate this technique for stability determination, data from a sequence of six periods between 6 p.m. on January 12, and 8:30 a.m. on January 13, 1974, were examined. These data are shown in Table 8. Throughout this period the wind trajectory was entirely over the Seattle central area so that the thermal influence of Lake Union was probably insignificant. Between the beginning of the period and midnight the wind averaged between 5.3 and 6.9 m/s (12-15 mph) from the south. The atmosphere was evaluated as unstable, which is reasonable since

the city is a heat source. By the time of the 2:30 a.m. observation the wind speed had begun to decrease and the stability classification had changed to neutral. This trend continued through the 5:20 a.m. observation, when the wind speed had died to less than 1.3 m/s (3 mph) and the atmosphere was classified as stable. In the next 3 hours there was a marked increase in wind speed accompanied by a decrease in atmospheric stability. The variation of the stability indicator  $\phi_m$  throughout this entire sequence is consistent with the other onsite measurements and expectations based on physical insight. As a result, the computed values of  $\phi_m$  were accepted as reasonable.

TABLE 8. VARIATION OF WIND PARAMETERS AND STABILITY DURING THE NIGHT OF JANUARY 12, 1974

<u>Test</u>	<u>Starting Time</u>	<u>Direction</u>	<u>Wind Speed</u> (m/s)	<u><math>u^*</math></u> (m/s)	<u><math>z_0</math></u> (m)	<u><math>\phi_m</math></u>
12-11	1800	189	5.90	0.66	0.25	0.75
12-1A	2020	188	5.28	0.66	0.52	0.78
12-13	2320	180	5.72	0.68	0.38	0.77
12-14	0220	174	4.43	0.46	0.88	1.1
12-15	0520	158	1.22	0.20	3.2	1.3
13-11	0740	188	8.11	0.84	0.62	1.0

Figure 18 shows the joint variation of the diabatic and adiabatic factors used to compute  $\phi_m$  for Lake Union extended tests. As would be expected for data taken near a surface heat source (city), the values tend to fall more toward the unstable area than the stable. This has been noted at other urban locations (Bowne and Ball, 1970). Lines have been included to distinguish those combinations considered to be stable or unstable from the neutral cases.

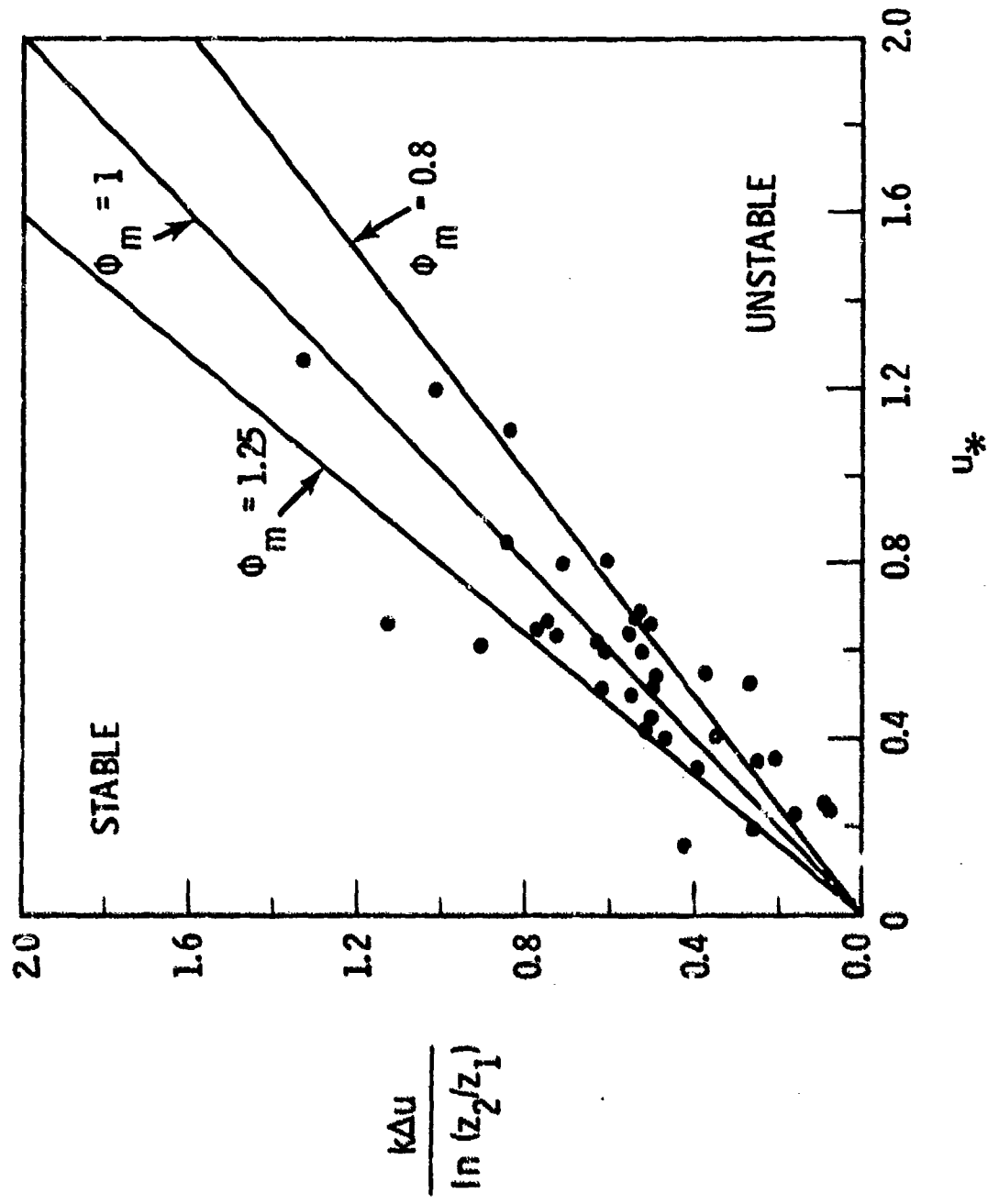

FIGURE 18. Joint distribution of the adiabatic,  $k\Delta u / \ln(z_2/z_1)$ , and diabatic,  $u_*$ , factors used in the computation of  $\phi_m$  for 37 extended tests at Lake Union.

## EVALUATION OF THE ROUGHNESS LENGTH AT LAKE UNION

Having classified the extended tests at Lake Union by stability, an effort was made to evaluate the roughness length,  $z_0$ , at the Lake Union site for wind flow across the city during a variety of atmospheric stabilities. Values of  $z_0$  were plotted as a function of wind direction to permit the identification of any directional dependence. The results are shown in Figure 19. As expected the roughness length is seen to be related to stability. The large values of  $z_0$  under stable conditions are associated with the roughness in the central business district of the city. The intermediate values associated with neutral conditions represent values typical of the 3-5 story buildings between the central business district and the site, and the small values of  $z_0$  associated with unstable conditions are associated with the relatively flat, tall grass covered area 100-200 m (300-650 ft) immediately upwind of the profile tower. The large value of  $z_0$  in unstable conditions at  $157^\circ$  is the result of flow over the freeway and several 5-6 story buildings within 300 m (1000 ft) of the site. Other than that, little variation of  $z_0$  with wind direction is discernable. As a general rule the approximation of  $z_0$  as  $1/30$  the height of the typical buildings or roughness elements appears to give good results, and an average of 0.6 or 0.7 m is reasonable for the site under southerly winds.

Roughness lengths associated with northerly winds were considerably lower. In the 2 unstable tests during northerly winds values of  $z_0$  were found to be less than 0.01 m.

Values of  $z_0$  used in the foregoing analysis were determined by extrapolation of the wind gradient between the second and third levels of the profile tower to the height at which  $\bar{u}$  went to zero. This process is illustrated in Figure 20.

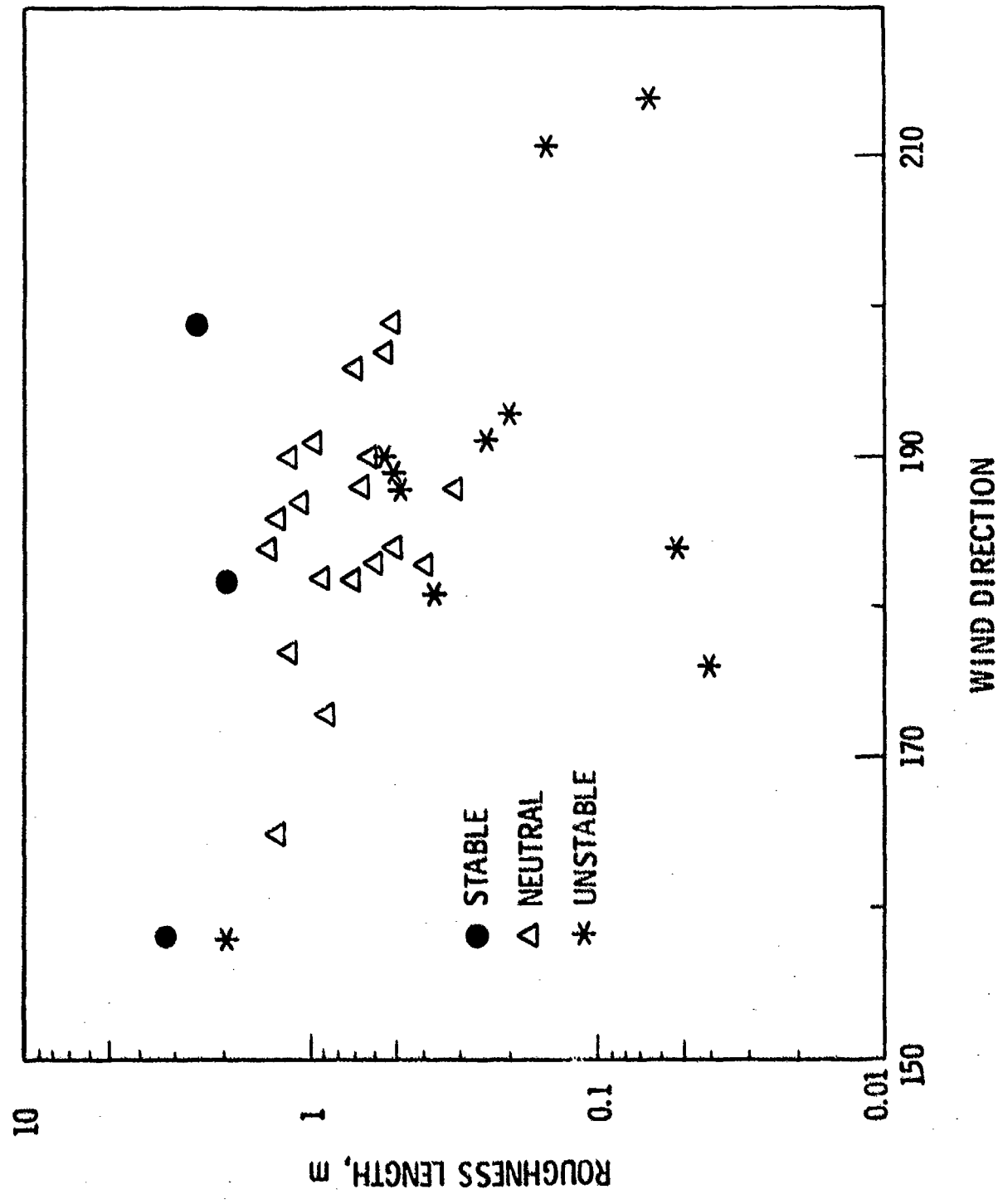

FIGURE 19. Variation in the roughness length,  $z_0$ , as a function of wind direction and stability.

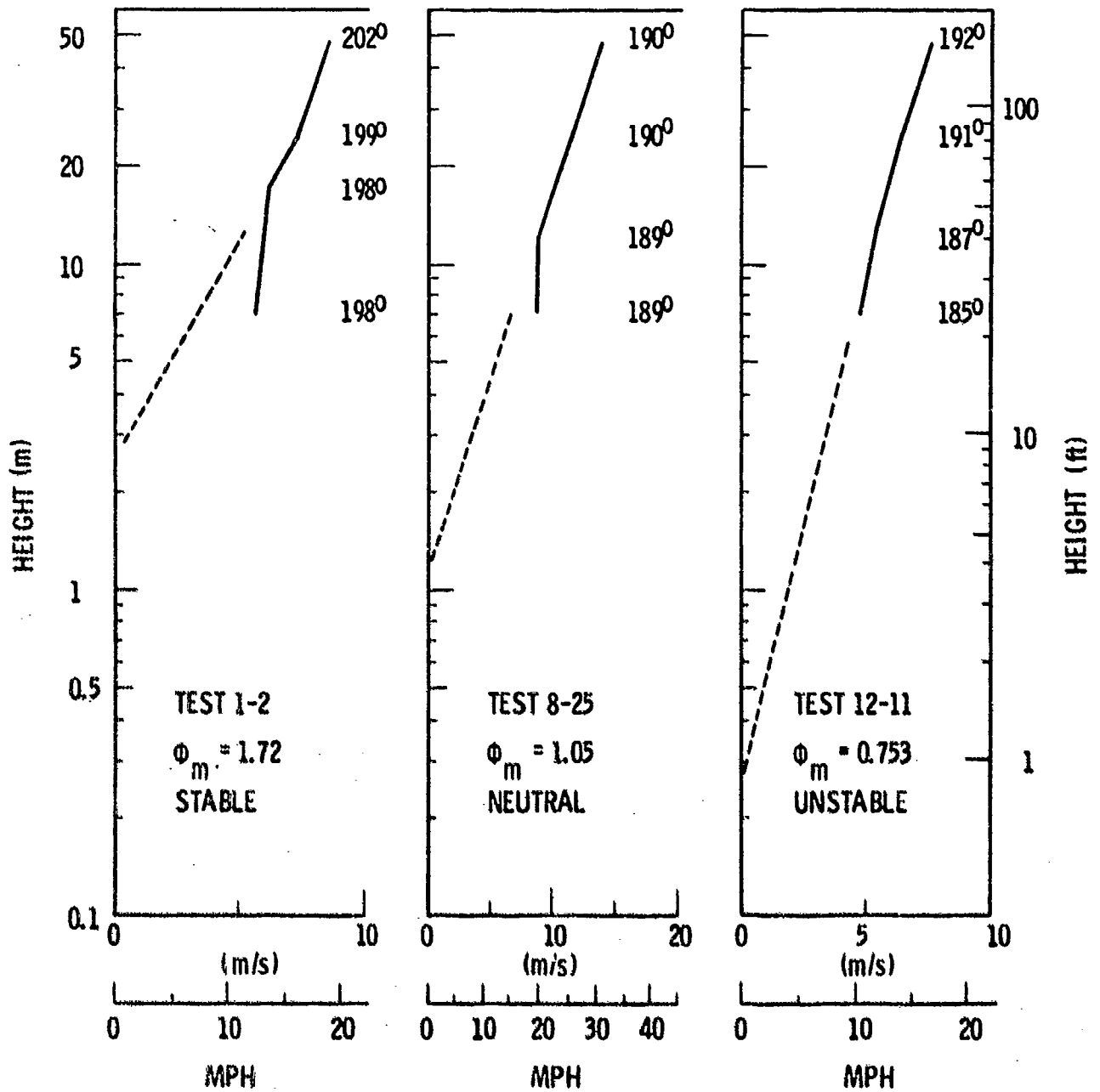

FIGURE 20. Wind profiles in stable, neutral and unstable conditions showing the extrapolation to determine  $z_0$ .

The dashed lines in this figure show the extrapolation in 3 tests, one for each stability category. This figure also shows the effect of stability on the growth of the internal boundary and transition layers. In both the stable and neutral cases the lowest wind instrument is obviously located in a layer which has been affected by the rough to smooth transition. As a result of the decreased surface friction over the smooth terrain, the lowest wind speed has increased above its previous equilibrium value resulting in the kink which is evident in the profiles. In the unstable case, apparently the 3 lowest layers, at least, are in the internal or transition layers. Little significance is attached to the curvature of the upper portion of the profiles. The wind direction at each level is given to the left of the profiles.

#### EFFECTS OF THE LENGTH OF OBSERVATION ON WIND PARAMETERS

The signal conditioning and data recording capabilities at Lake Union made it possible to simultaneously record data for both the intensive and climatological measurement programs. As a result of this capability, there were 24 cases where climatological data were collected within an hour of the times for which extended run data were analyzed. (Failure of the tape recorder used in collection of the climatological data accounted for the other 13 possible cases.) Comparisons of the mean wind speed, rms gust velocities  $(\sigma_y^2)^{1/2}$  and the integral length scales for each component have been made to identify systematic biases resulting from differences in data acquisition and processing between the experimental programs. Table 9 presents average statistics for these 24 tests. The upper row for each height contains the averages for the extended runs and the lower row contains the averages from the climatological data. Other than the difference in the length of the observation

periods, the only difference in the collection or processing of the data was in the detrending of the initial time series prior to spectral analysis. It will be remembered that best fitting second-order polynomials were used to detrend the data from the extended runs, while only linear trends were removed from the climatological data.

TABLE 9. COMPARISON OF WIND STATISTICS FROM EXTENDED RUN AND CLIMATOLOGICAL MEASUREMENTS MADE AT APPROXIMATELY THE SAME TIME

Measurement Height (m)	Mean Wind Speed (m/s)	RMS Gust Velocities			Integral Length Scales		
		$\sigma_u$ (m/s)	$\sigma_v$ (m/s)	$\sigma_w$ (m/s)	$L_u$ (m)	$L_v$ (m)	$L_w$ (m)
6.9	4.06	1.34	1.03	0.62	70	49	12
	4.18	1.23	1.00	0.62	35	34	10
12.6	4.54	1.39	1.11	0.79	82	56	14
	4.64	1.27	1.05	0.81	43	36	14
24.8	5.56	1.55	1.16	0.94	104	70	20
	5.57	1.35	1.02	0.94	49	32	17
48.2	6.62	1.64	1.06	0.81	138	88	36
	6.20	1.56	0.92	0.65	65	28	20

The data in the table show remarkable agreement between mean wind speed and rms gust velocity averages at all levels. The two experimental programs are considered to provide equivalent data in these areas. Significant differences are apparent in the computed integral length scales. The length scales for the horizontal wind components computed from climatological data are approximately 50 percent of the comparable values for extended runs. Had quadratic detrending been used on the climatological data, the length scales derived from those data would have been even smaller. Thus, the differences are considered to be the result of differences in the length of

the observation periods. Horizontal motions exist at low frequencies which do not contribute significantly to the climatological data length scales and which are not effectively removed from the extended run data. The absence of low frequency motions in the vertical are responsible for the generally excellent agreement between the vertical length scales.

Additional comments on the effects of the length of record and detrending will be made as the data from the survey are compared with other data. In addition, effects of lack of instrument response on low-level wind statistics will be covered later.

## CHAPTER 7

### WIND COMPONENT POWER SPECTRA

Having completed the development and review of background information, this chapter will qualitatively examine the details of wind component spectra computed from the extended measurement experiments and compare them with other data and existing models. To identify the dominant features of these spectra, composite spectra have been formed by geometrically averaging the banded spectral estimates from the individual tests.

#### SCALING OF THE SPECTRA

Variations in meteorological conditions between tests required that the individual spectra be normalized prior to averaging. Three frequency scales were tried:  $n$ ,  $n/\bar{u}$ , and  $nz/\bar{u}$ . Within a given test the spectra at various heights organized well when plotted against either  $n$  or  $n/\bar{u}$ . When the nondimensional frequency  $nz/\bar{u}$  was used, the horizontal spectra became scattered; only the vertical component spectra remained organized. Comparisons between tests indicated that the use of  $n/\bar{u}$ , the inverse wave length, provided significantly better results than did the use of frequency alone. This corresponds to the findings of Brook (1972) for turbulence data collected in Melbourne, Australia. An implication of this finding is that the climatological variations of the length scale are relatively smaller than the climatological variations of time scale.

Selection of scaling parameters for the spectral estimates themselves did not provide significant problems. The natural

scaling parameter in the boundary layer is  $u_*^2$ . However, this parameter was readily discarded in favor of the variance of the component being examined. This choice was made for two reasons. The first is that the integral over frequency of spectra scaled with the variance is unity on the basis of the relationship given in Equation (2-8). The second reason for selecting the variance is that spectral models in current usage in flight simulation are scaled in this manner.

#### LAKE UNION SPECTRA

Variation of wind profiles with stability and change of roughness has been discussed previously. In the present context, however, it is appropriate to consider a composite wind profile which represents the mean atmospheric conditions corresponding to the composite spectra to be examined. This fictional profile is shown in Figure 21. The roughness length associated with the wind between the 12.6 and 24.8 m levels is 0.6 m and  $u_*$  for that layer is approximately 0.30. In the lowest layer,  $u_*$  is somewhat less.

As a starting point, composite spectra were formed from data from 34 of the 37 periods analyzed. The remaining 3 periods had time series limited to 2048 data points. These data were analyzed separately; their inclusion would not have altered the results. Composite spectra from the combination of 34 Lake Union tests are shown in Figure 22 grouped by component; the longitudinal component spectra appearing in the upper box, the lateral component in the middle box, and the vertical component in the lower box. (This format of examining the components separately will be followed in most cases.) The composite spectra are labeled with the height of measurement.

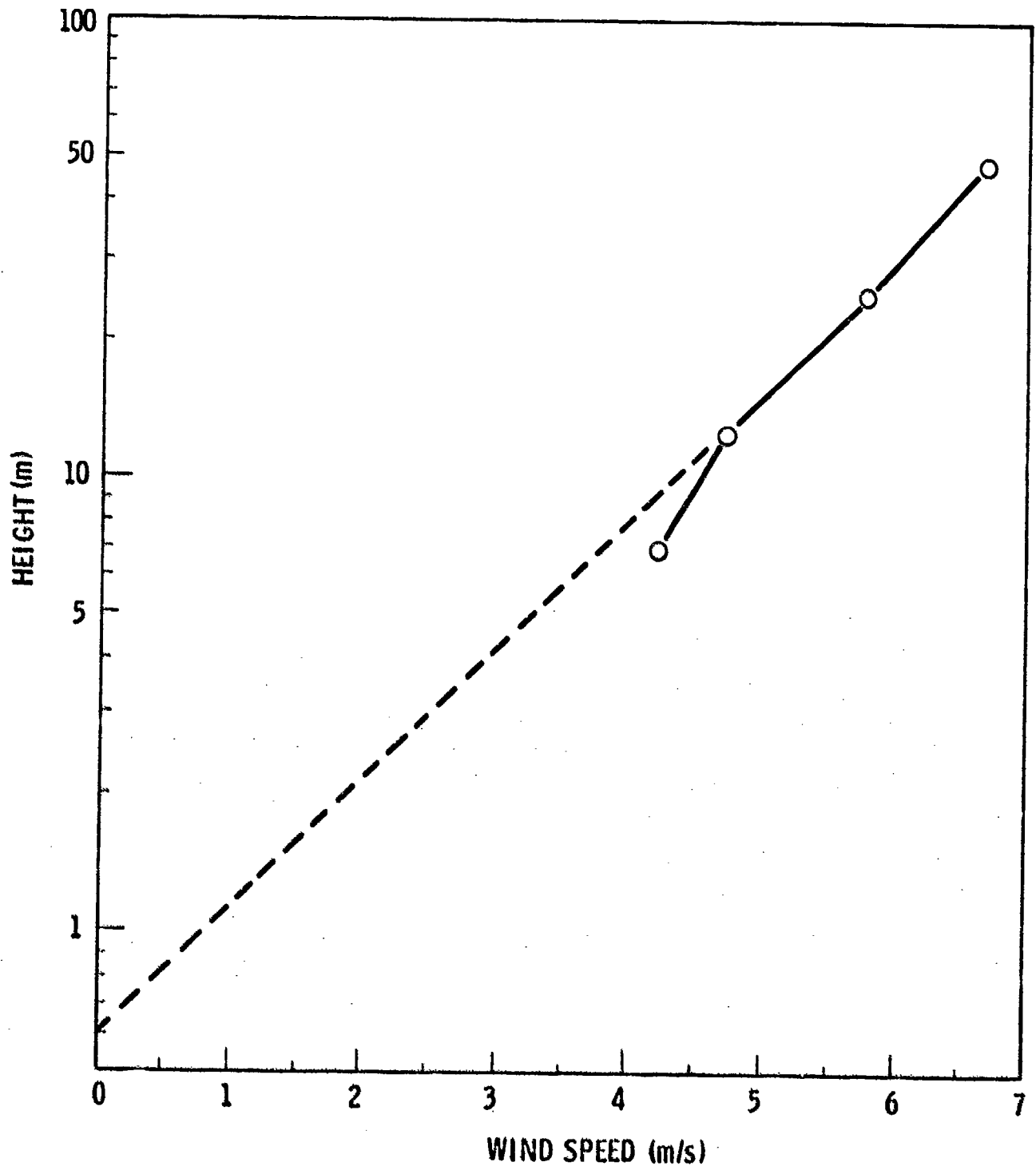

FIGURE 21. Composite wind profile for the extended tests at Lake Union.

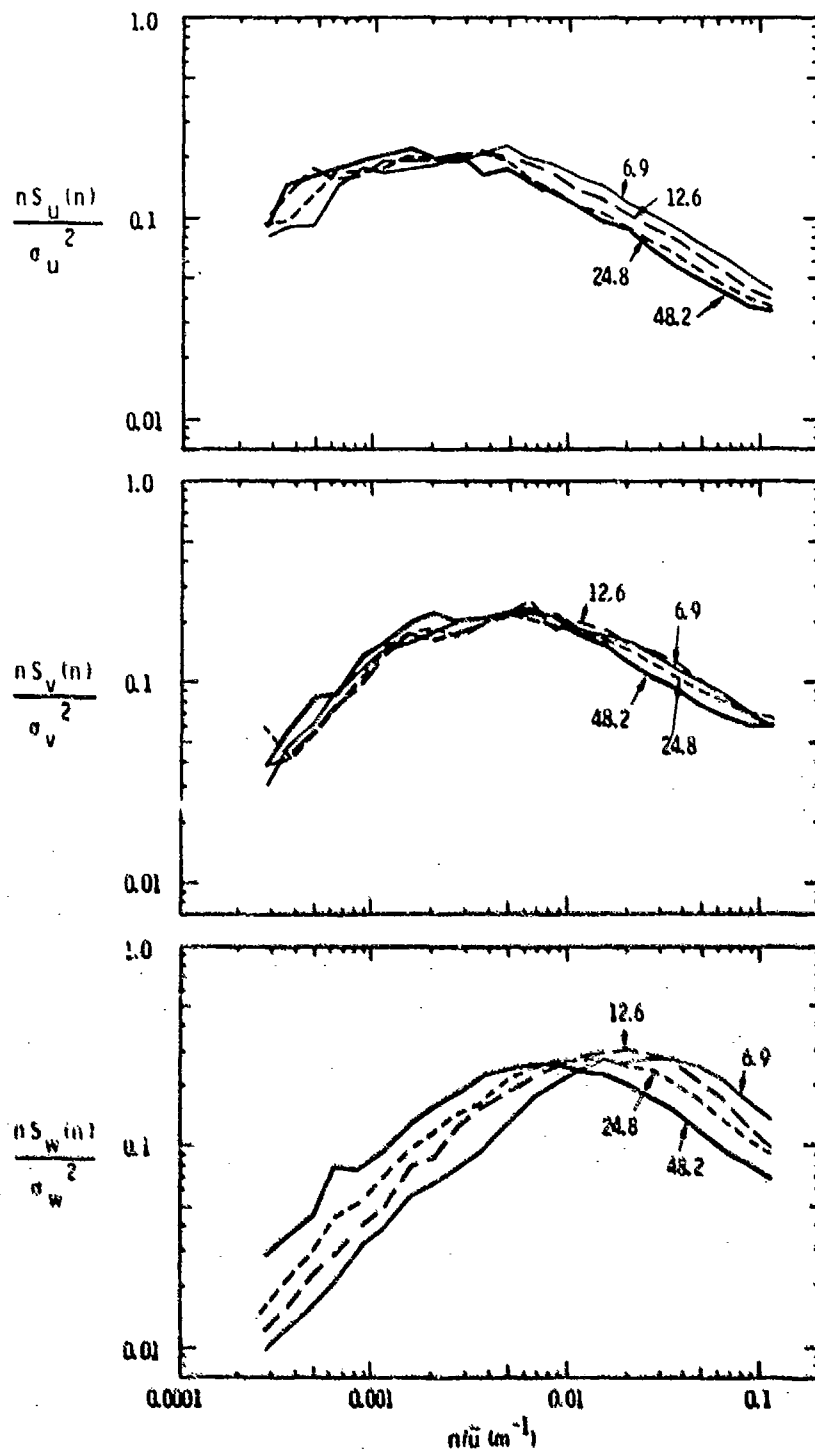

FIGURE 22. Composite spectra for the Lake Union intensive measurement data.

In general these spectra show a marked similarity to the spectra which have been obtained in conventional turbulence measurement programs. Specifically, they show the common tendency for the normalized frequency-multiplied spectral estimates,  $nS(n)/\sigma^2$ , to decrease proportional to  $(n/\bar{u})^{-2/3}$  at high frequencies. This result is indicative of the presence of an inertial subrange in the turbulence. This point will be examined in further detail shortly. The increase in  $nS(n)/\sigma^2$  proportional to  $n/\bar{u}$  at low frequencies for the  $v'$  and  $w'$  spectra is also a common feature of wind turbulence spectra. The figure shows rudimentary evidence that this same relationship would hold for the longitudinal spectra had longer time series been analyzed. A third feature these spectra have in common with other atmospheric spectra is the gradual transition between the regions having slopes of +1 and -2/3. This transition occurs much faster in the vertical component spectra than in those for the horizontal components.

Figure 22 provides an opportunity to examine the variations in each component spectra as a function of height. The spectra shift toward lower frequencies as the height above the ground is increased. This shift is most pronounced for the vertical component spectra which is not surprising since they tended to organize well with the use of the nondimensional frequency,  $nz/\bar{u}$ . The shift of the horizontal component spectra toward lower frequencies is significantly less than for the vertical component spectra. This is an indication that the horizontal component spectra may be related to height in a different manner than the vertical component spectra.

The Interim Report listed three features of a classical inertial subrange. In addition to the -2/3 slope at high frequencies, the features were: vanishing of the cross spectra and spectral values for the  $v'$  and  $w'$  components 4/3 those

of the  $u'$  component. To examine the last feature, composite spectra for these tests were prepared for the 6.9 and 48.2 m levels with spectral estimates normalized to  $u_*^2$  rather than to the component variance. Figures 23 and 24 show the results of this. (In these figures the three component spectra are shown together to facilitate the desired comparison.)

These figures show that the  $4/3$  relationship required of the classical inertial subrange and predicted by theory is not present even though the individual spectra show  $-2/3$  slopes. The predicted relationship is more nearly approached at the lower level. Here the  $v'$  and  $w'$  spectral values are equal, but they are smaller rather than larger than the  $u'$  spectral values. At the upper level the situation is farther from the theoretical prediction, even though a more extended  $-2/3$  region is evident. It is therefore concluded that the inertial subrange, in the classical sense, is not evident in the frequency range sampled. However, the use of the term inertial subrange will be continued in a loose sense to describe the region of the spectra which possesses the  $-2/3$  slope. In passing, it should be noted that failure to observe the  $4/3$  ratio is common in experimental studies of atmospheric turbulence, even in those studies conducted in more nearly ideal surroundings.

Returning to consideration of the Lake Union composite spectra, a variety of groupings of the data were made to examine the effect of stability and wind direction. Composite spectra were formed from those tests evaluated as stable and unstable on the basis of  $\phi_m$ . When these spectra were compared, no significant differences were found. Similarly, when the data were grouped by wind direction and composite spectra computed, there were no apparent differences. This is not to say that there were no differences, only that under scaling by  $u_*^2$

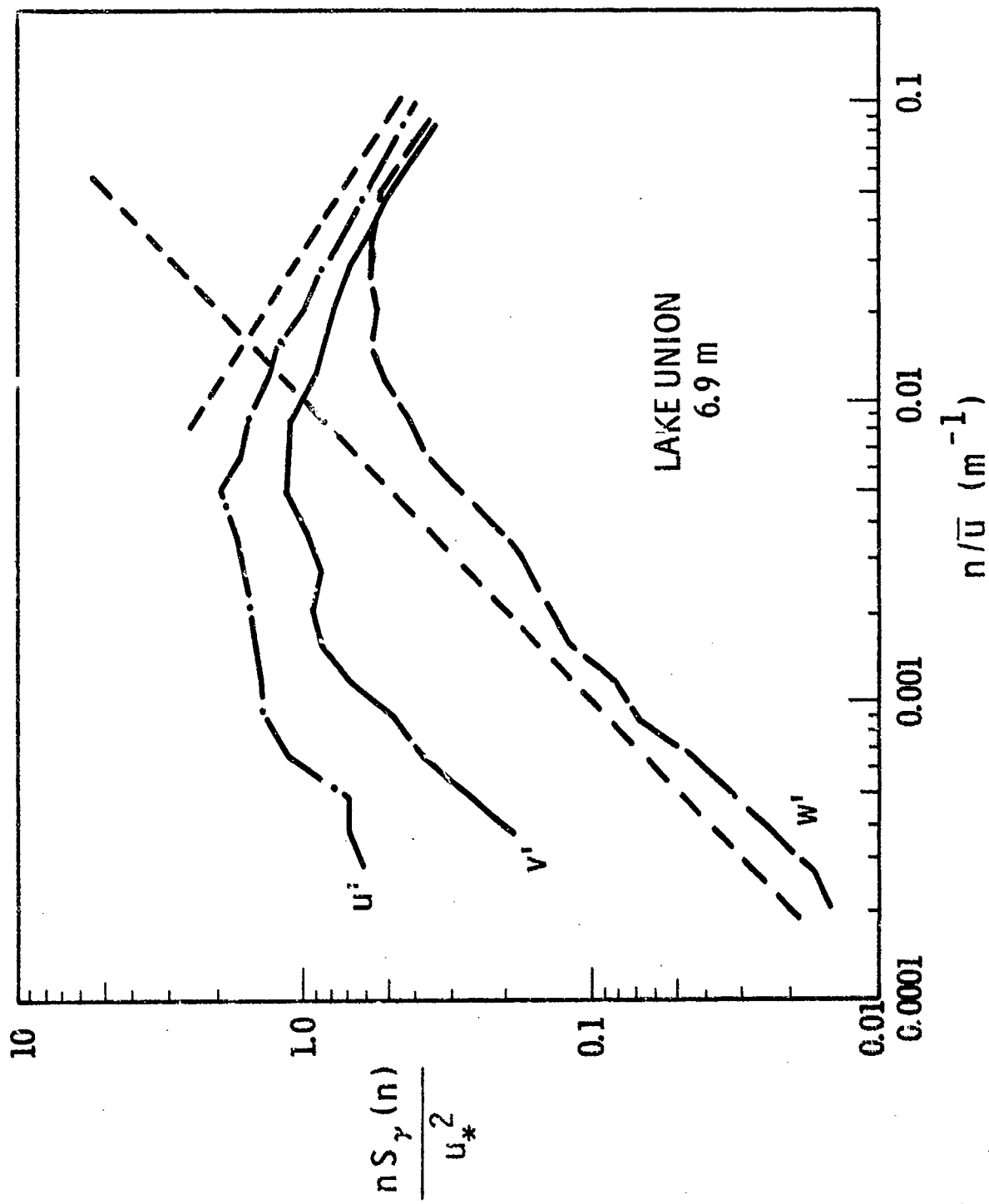

FIGURE 23. Lake Union 6.9 m extended test composite spectra normalized to  $u_*$ .

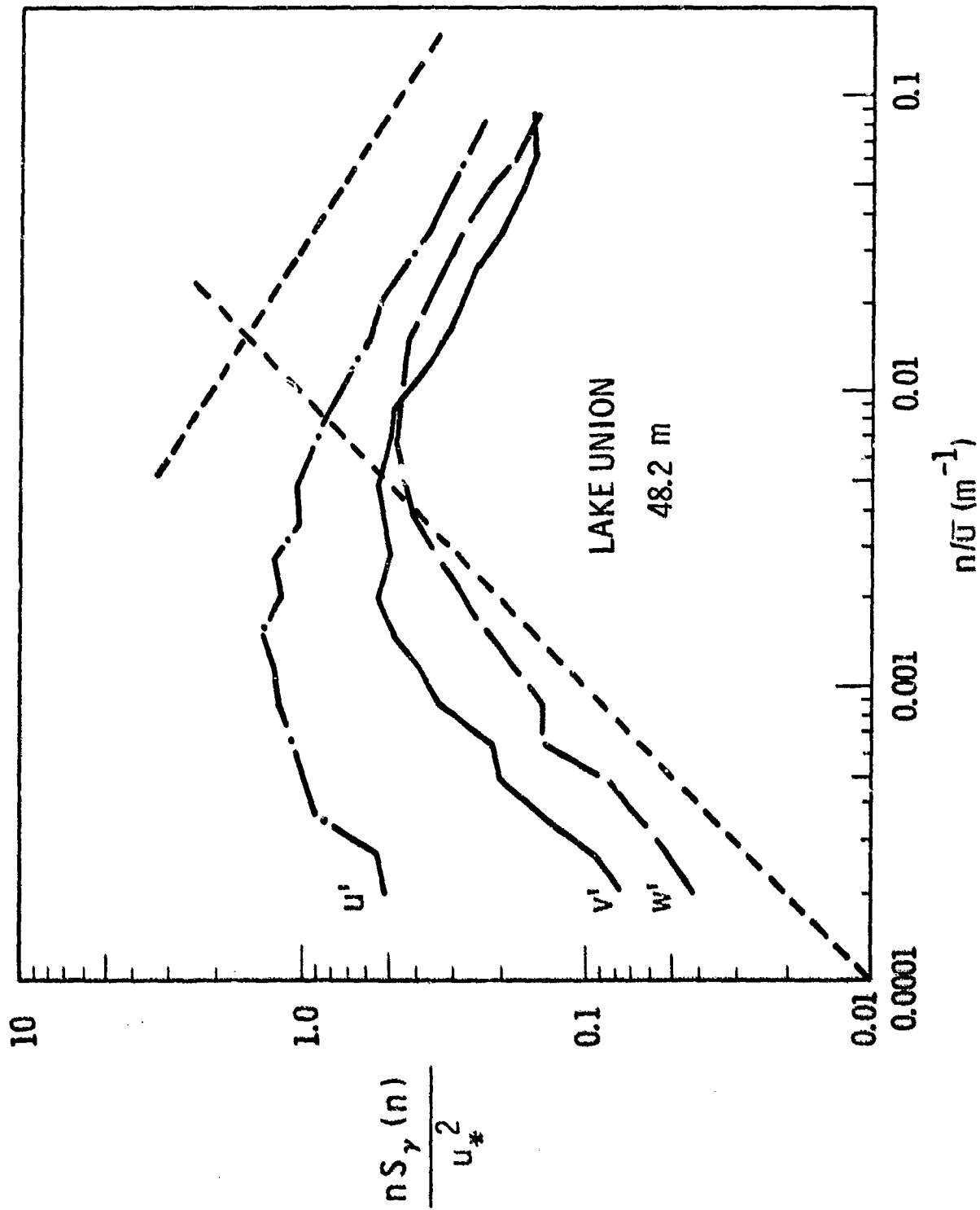

FIGURE 24. Lake Union 48.2 m extended test composite spectra normalized to  $u_*^2$ .

and  $\bar{u}$  the differences were not apparent. Variation of  $\sigma_y^2$  as a function of direction will be discussed in a later chapter.

#### KIXI SPECTRA

Intensive measurement data from 10 periods at KIXI were analyzed. The data from these tests were combined in the manner of the Lake Union data. The resulting composite spectra are shown in Figure 25. These spectra show essentially the same basic features as the Lake Union spectra. There are several points of differences which are worth noting, however.

The first difference is in the transition between the regions having +1 and -2/3 slopes. The KIXI transition regions for the horizontal component spectra are more abrupt than are their counterparts at Lake Union. It is not known whether this is a real difference or the result of the limited number of extended tests at KIXI. If the difference is real, then it has an interesting ramification in modeling. It may be necessary to model the change of spectral shape as a function of height above the surface as well as the length scale and variance.

A second difference of interest is that the horizontal component spectra do not shift toward lower frequency from the lower to the upper level. This indicates that the relevant reference level is ground level rather than the roof.

Out of the 10 periods for which KIXI extended test data were analyzed, 9 occurred during periods when the wind direction was between 168 and 185° at the lower level. The other test was conducted during a period when the wind was out of the NNW. When composite spectra for the southerly tests were compared with the spectra for the single northerly test, a

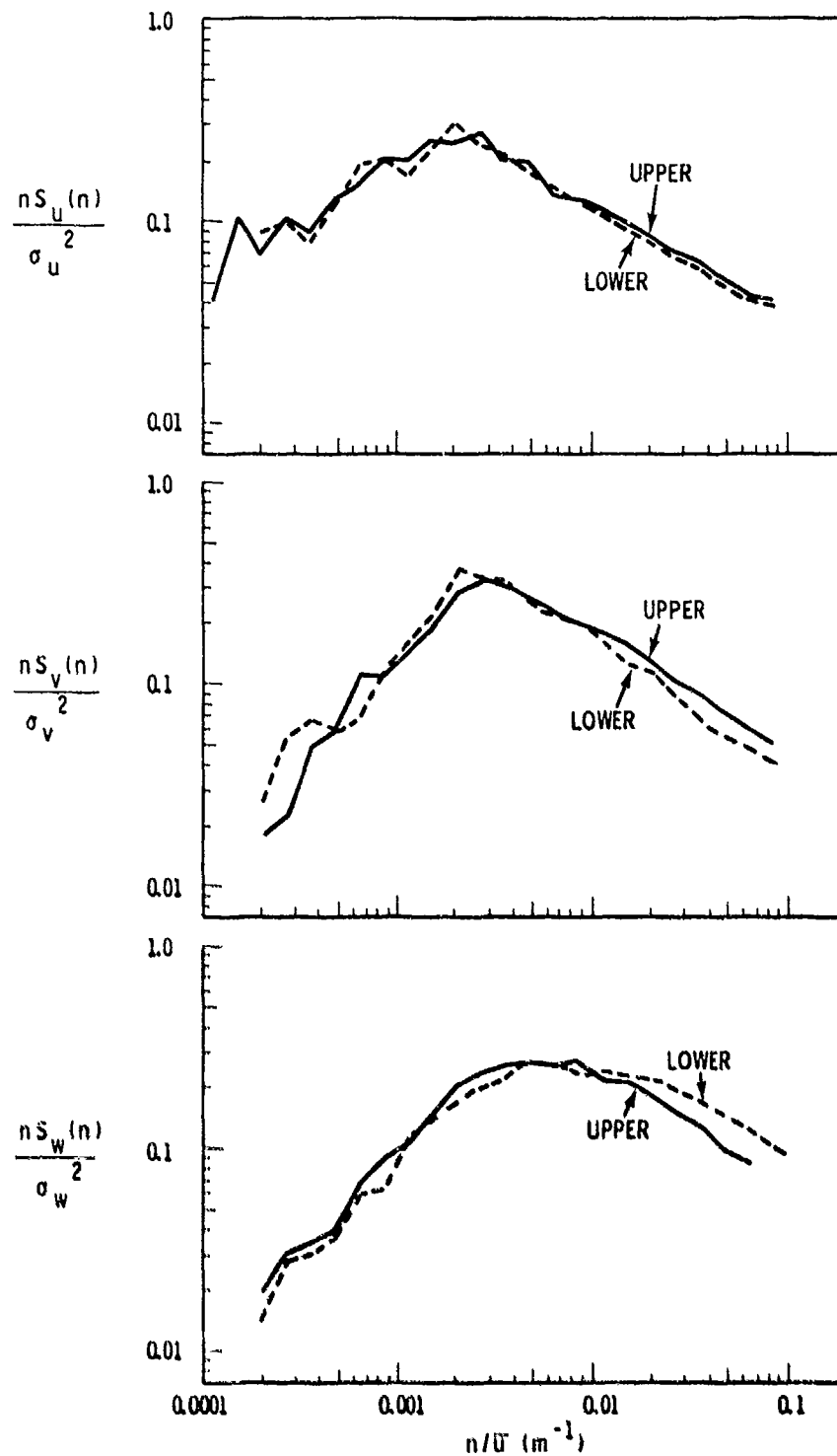

FIGURE 25. Composite spectra for the KIXI intensive measurement data.

distinct difference in position was noted. The northerly spectra were shifted to significantly lower frequencies. However, when climatological data on length scales were examined, this shift did not appear to be a consistent feature.

No attempt was made to evaluate stability at KIXI nor to separate the KIXI data by Lake Union stability classification.

#### INTERSITE SPECTRAL COMPARISONS

Composite spectra for Lake Union and KIXI tests have been compared with composite spectra computed for 3 test periods at SEA-TAC. These comparisons are shown in Figures 26 and 27.

The spectra shown in Figure 26 are for the lowest level on each tower. Three inferences seem warranted from this figure. First, the spectra from KIXI are shifted to lower frequencies than those from Lake Union and SEA-TAC. This would follow directly from the previous discussion which indicated that the relevant reference plane was ground level rather than the roof. The second inference is that, except for the relatively abrupt transition between the +1 and -2/3 slope regions in the  $v'$  spectra at KIXI, the spectra from all three sites have essentially the same shape. The final inference is that there is no significant difference indicated in either slope or position between comparable spectra at Lake Union and SEA-TAC.

The last two inferences are particularly important. If supported by the climatological data, these inferences lend considerable weight to the use of a common spectral model in the simulation of turbulence for terminal flight in both urban and rural environments. It would only be necessary to alter the variances and possibly the length scales to compensate for any differences in turbulence in the two environments.

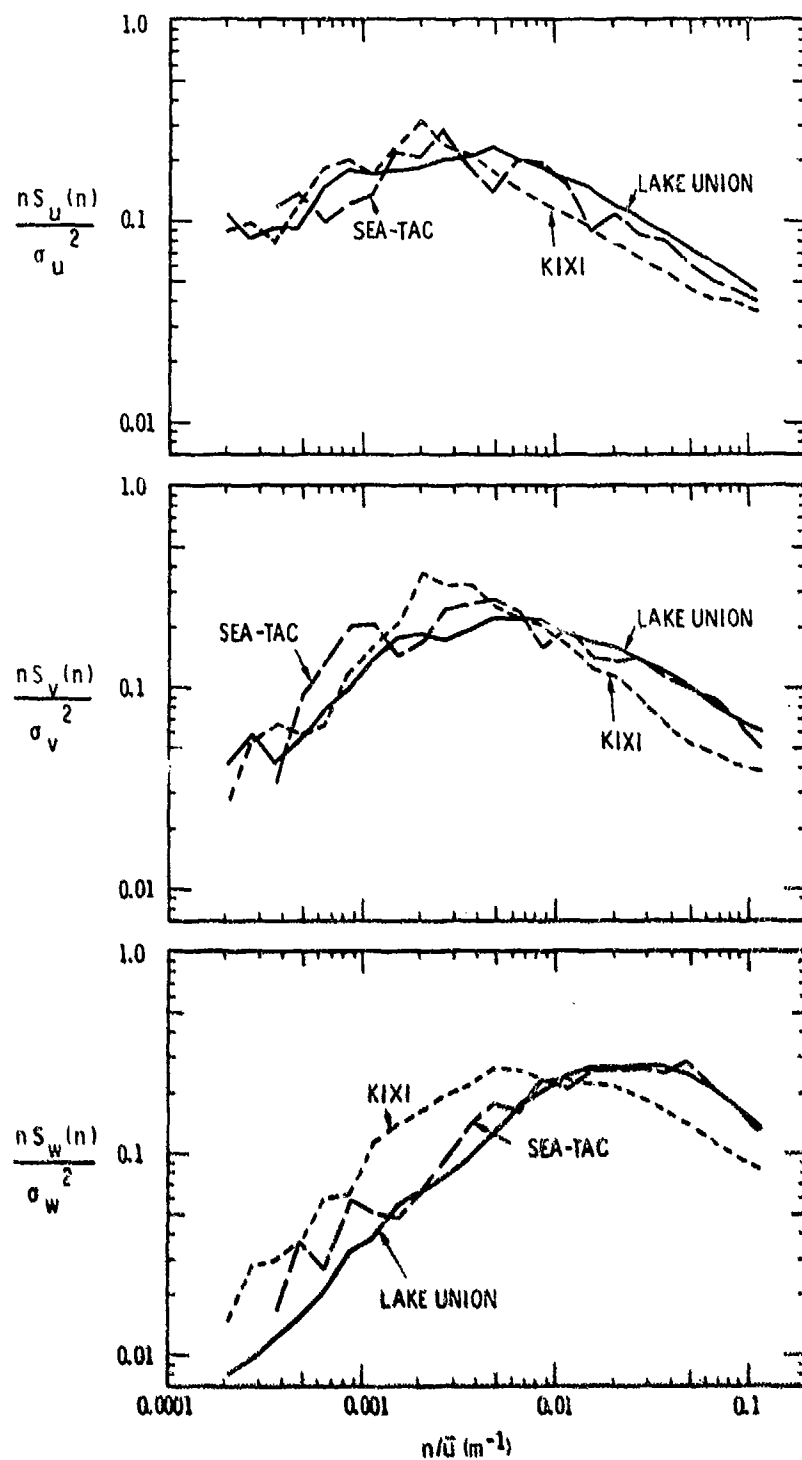

FIGURE 26. Comparison of composite spectra from the nominal 7 m level at the 3 survey sites.

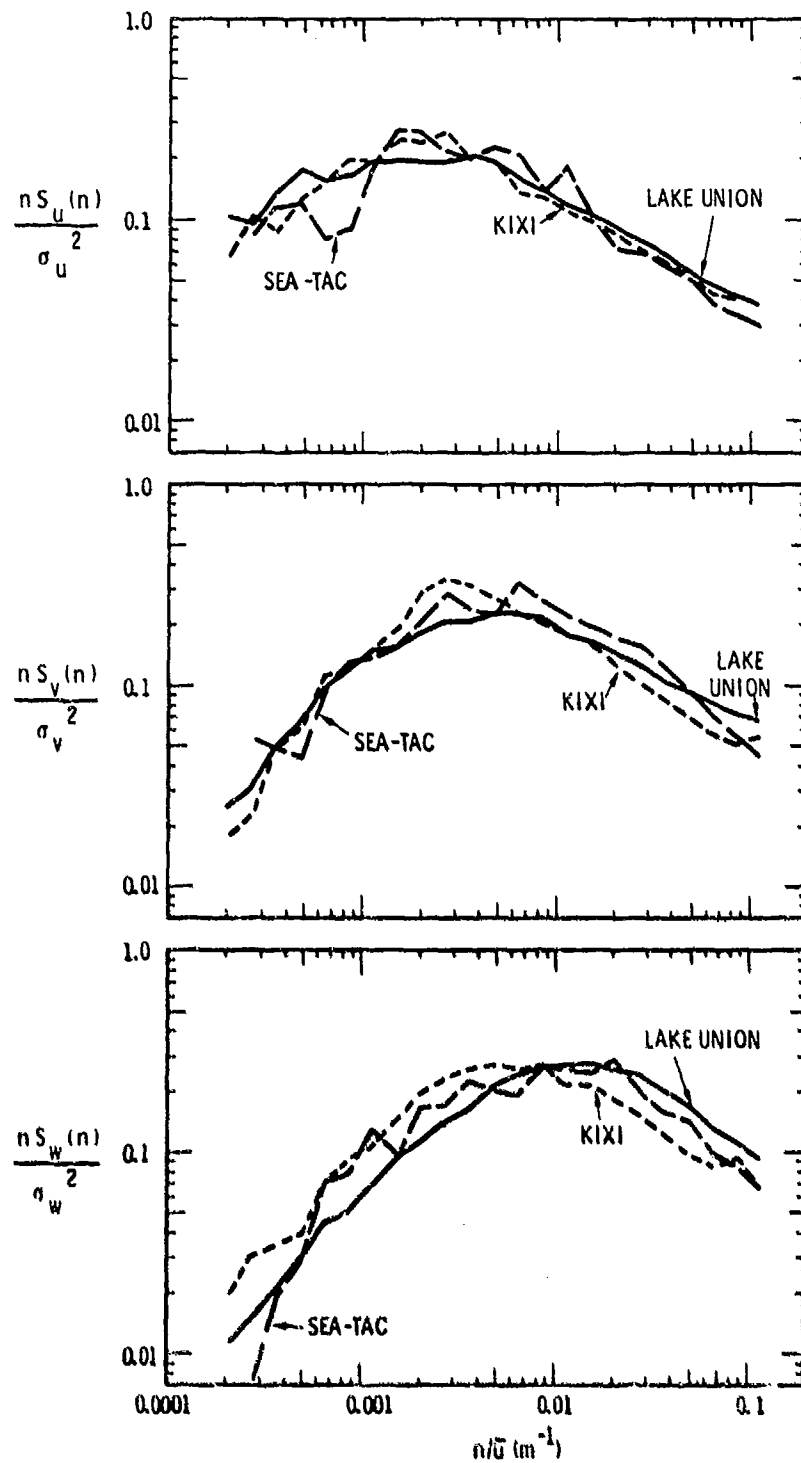

FIGURE 27. Comparison of composite spectra from the nominal 25 m level at the 3 survey sites.

Figure 27, which is similar to 26, compares the composite spectra computed from data collected at a nominal 25 m level on each of the towers. The inferences drawn from the spectra at the lower levels are supported by the spectra at this level. In addition, it is interesting to note that the horizontal component spectra from KIXI no longer appear shifted toward lower frequencies and that the sharp transition region of the v spectra still appears anomolous.

#### FURTHER SPECTRAL COMPARISONS

On the basis of the intersite comparisons, the survey data appear to be a consistent set which can be used to evaluate existing turbulence models for application to V/STOL aircraft design, certification and flight simulation. Further verification of this conclusion was sought by comparing the survey data with data obtained in other measurement programs and with von Karman spectra computed using turbulence length scales obtained from the survey measurements. (The mathematical formulation of the von Karman spectral model is discussed in the Interim Report.) The results of these comparisons are presented in Figures 28 and 29. Actual composite spectra from the survey measurements are not shown in these figures, instead a shaded area is used. This area represents the region covered by  $\pm$  one standard deviation of the individual banded spectral estimates about composite spectral estimates. The spectra to be compared with the survey data are represented by the curves included in the figures.

Atmospheric turbulence data used in the comparison were obtained in Melbourne, Australia, by Brook (1972). Brook's measurements were made at 3 levels on a 18.5 m tower located on the roof of a 10 m building using Gill anemometers. The top level data have been used in this comparison because nearby

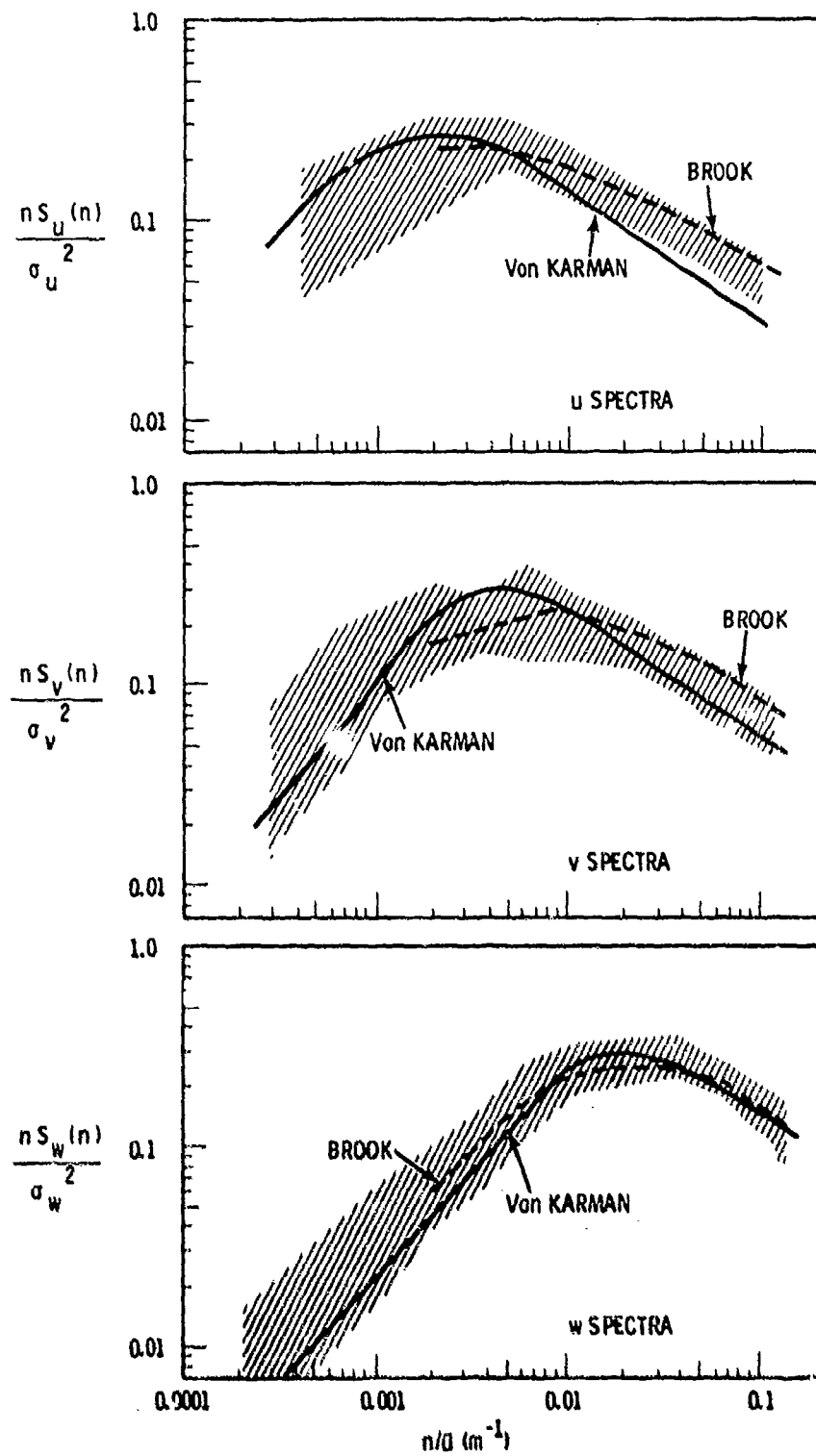

FIGURE 28. Comparison of Brook's average spectral estimates and the von Karman spectral model with Lake Union 6.9 m data.

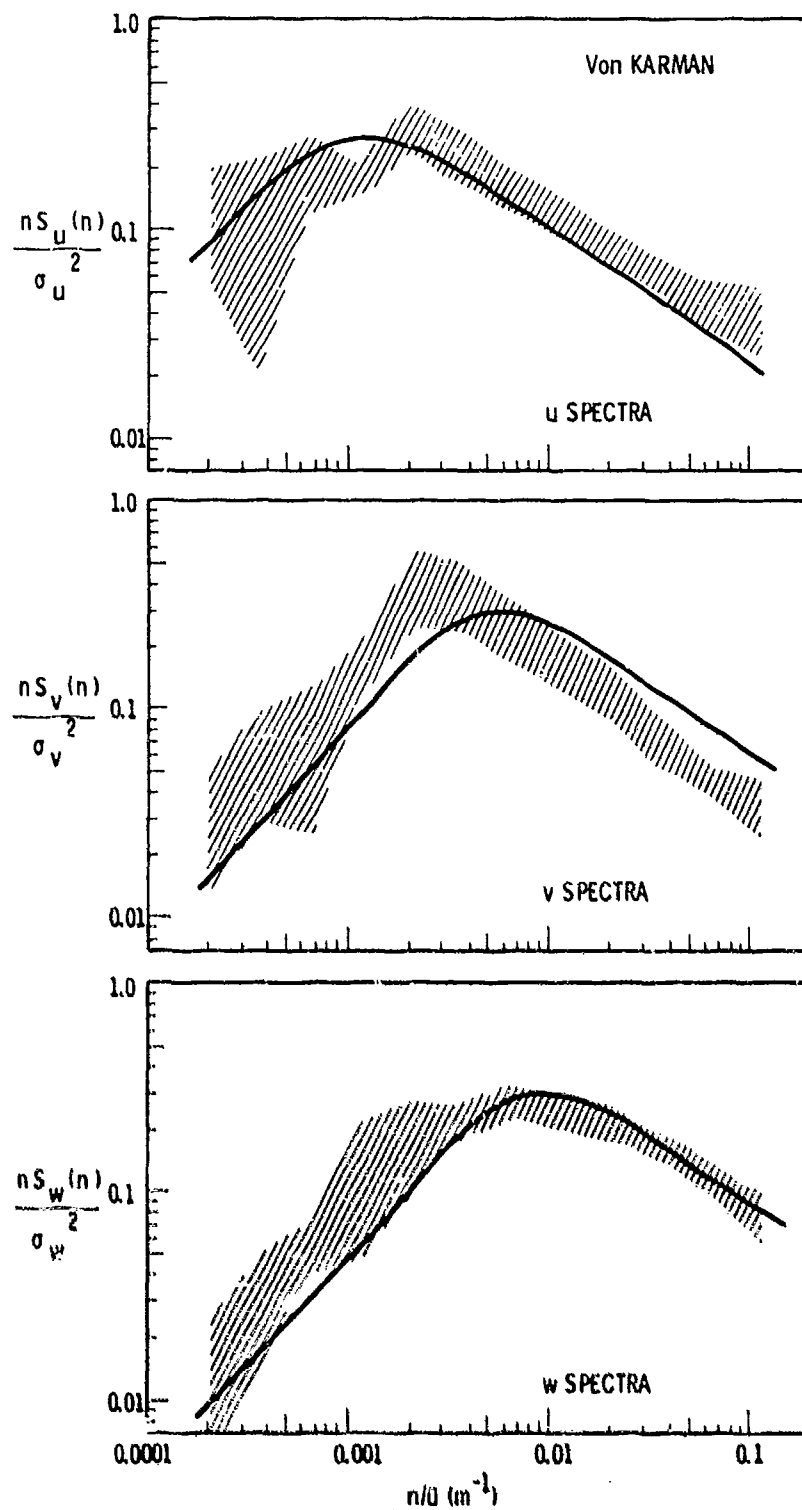

FIGURE 29. Comparison of the von Karman spectral model with KIXI upper level data.

buildings (within 80 m) extended to about the 12 m level of the tower. The curves shown represent composites of data from 15 to 50 different tests.

Figure 28 shows the comparisons for the lowest level data at Lake Union. The smooth curves extending over the entire range are von Karman spectral models computed using the average length scales for the Lake Union site. It is apparent that the measured length scales are larger than needed to provide an optimum position for the von Karman spectra. The discrepancy is most evident in the u spectra. The differences in transition from the +1 to the -2/3 slope regions between the von Karman spectral model and atmospheric measurements are also evident. In particular the modeled transition for the horizontal turbulence components is too abrupt.

The shorter curves on this figure are Brook's composite spectra. They compare very favorably with the survey data. When the w component composite spectra for Melbourne and the Lake Union are plotted on the same graph, the similarity in both position and shape makes the curves nearly indistinguishable. This similarity has important ramifications in establishing the generality of the results from a specific site. As a result of this comparison there can be more confidence in the application of the Seattle data to other sites.

Comparison of the von Karman spectral model and the 48.2 m data from Lake Union (not shown) also indicates that the measured length scales are too large and the model transitions are too abrupt.

In Figure 29 the von Karman spectral model is compared with data from the upper level at KIXI. In this instance the measured longitudinal length scale is too long, but both the

lateral and vertical length scales have been under-estimated. The rate of transition from a +1 to a  $-2/3$  slope matches the data reasonably well. Comparison of the model with data from the lower level also shows the features just described.

On the basis of the qualitative comparisons presented, it was concluded that the survey climatological data could reasonably be analyzed in the context of existing turbulence models. Accordingly, the climatological data were organized to evaluate the variation of turbulence intensities (the ratio of component rms gust velocities to the mean wind speed) and the integral length scales. In the next chapter the spectral model of Fichtl and McVehil (1970) is fitted to the Lake Union turbulence data. In following chapters, models are developed for rms gust velocities and length scales.

## CHAPTER 8

### SPECTRAL MODELS FOR THE URBAN ENVIRONMENT

In the previous chapter composite spectra were examined for each of the survey sites. These spectra showed a marked similarity to each other, to spectra from other sites and to the von Karman spectral models. It has therefore been concluded that the existing approaches to modeling atmospheric boundary layer turbulence are a reasonable starting point in development of spectral models for simulation of turbulence for application to V/STOL aircraft operations in an urban terminal environment. The requirements for development of models are: 1) a spectral form, 2) a turbulence rms value and 3) a turbulence length scale. In this chapter the development of a spectral form will be undertaken. In the next two chapters, models will be developed for rms gust velocities and length scales.

#### BASIC SPECTRAL MODEL

The Interim Report starts its discussion on atmospheric boundary layer spectra with a model proposed by Fichtl and McVehil (1970). This model is

$$\frac{nS_{\gamma}(n)}{u_*^2} = \frac{[C_{\gamma} \bar{\epsilon} / (f_m)_{\gamma}]}{\left\{ 1 + 1.5 \left[ \bar{\epsilon} / (f_m)_{\gamma} \right] z_{\gamma} \right\}^{5/3} z_{\gamma}}$$

$$\gamma = u, v, w \quad , \quad (8-1)$$

where:  $f$  is the nondimensional frequency  $nz/\bar{u}$ ,  $(f_m)_{\gamma}$  is the

frequency at which the maximum value of  $nS_Y(n)$  is attained, and  $C_Y$  is a coefficient which adjusts the magnitude of the spectra at all frequencies. The exponent  $r_Y$  is used to vary the curvature of the spectra in the transition region between the low frequency region, where  $nS_Y(n)$  is proportional to  $f/f_m$ , and the high frequency region, where it is proportional to  $(f/f_m)^{-2/3}$ . Thus, these spectra have the same properties in the high and low frequency regions that are possessed by the von Karman spectra. In addition, they have a variable transition region which can be fitted to observed data. This will be the starting point for the current model effort.

#### MODEL DEVELOPMENT

An additional relationship is needed to convert Equation (8-1) to the more familiar form in which  $nS_Y(n)/\sigma_Y^2$  is a function of the dimensional frequency  $n$ , the wind speed  $u$ , and the length scale. Therefore, it is assumed that

$$(\lambda_m)_Y = 2\pi L'_Y = 2\pi A_Y L_Y = 2\pi A_Y \bar{u} \tau_Y \quad (8-2)$$

where  $(\lambda_m)_Y$  is the wave length at the peak of the spectrum,  $L'_Y$  is the length scale associated with  $(\lambda_m)_Y$ ,  $L_Y$  is the integral length scale and  $A_Y$  is a constant of proportionality between the length scales.  $A_Y$  may have different values for each component.

In addition to assuming the relationship in Equation (8-2), it is necessary to evaluate the relationships between the component rms gust velocities and  $u_*$ . According to boundary layer theory, the ratios between the component rms gust velocities and  $u_*$  should be a function only of the nondimensional height,  $z/L$ , or in the case of the survey,  $\phi_m$ . Previous turbulence studies have produced conflicting results on this

point. It was therefore necessary to examine these relationships with urban data. This evaluation was accomplished using the extended test data from Lake Union. Figure 30, which shows this evaluation, reveals that any relationship which might exist between the ratios and stability is weak. For engineering applications the assumption of average values of 2.5 for  $\sigma_u/u_*$ , 2.0 for  $\sigma_v/u_*$ , and 1.5 for  $\sigma_w/u_*$  is all that is warranted by the data. These values are in close agreement with the values 2.5, 2.3, and 1.35 offered by Panofsky et al. (1970) for heterogeneous terrain. The circled data were obtained during northerly winds and may have been affected by the profile tower's wake. Making the appropriate substitutions, Equation (8-1) becomes

$$\frac{n S_Y(n)}{\sigma_Y^2} = \left[ \frac{2\pi C_Y}{(\sigma_Y/u_*)^2} \right] \frac{(n L'_Y/\bar{u})}{\left\{ 1 + 1.5(2\pi n L'_Y/\bar{u})^{r_Y} \right\}^{5/3} r_Y} \quad (8-3)$$

#### MODEL PARAMETER EVALUATION

Kaimal (1972) has presented data which were used as initial estimates of values for  $C_Y$  and  $r_Y$  for neutral atmospheric conditions. These estimates were presented in the Interim Report and are repeated in Table 10 along with average ratios of the rms gust velocities to  $u_*$ . In addition, Table 10 contains an evaluation of the constant term which is in brackets in Equation (8-3).

Spectra for each component were plotted as a function of  $(n L'_Y/\bar{u})$  using Equation (8-3) and the parameter values in Table 10. These spectra were then compared with the envelopes of observed spectral estimates at 6.9 and 48.2 m during the extended tests at Lake Union. Based on this fitting process,

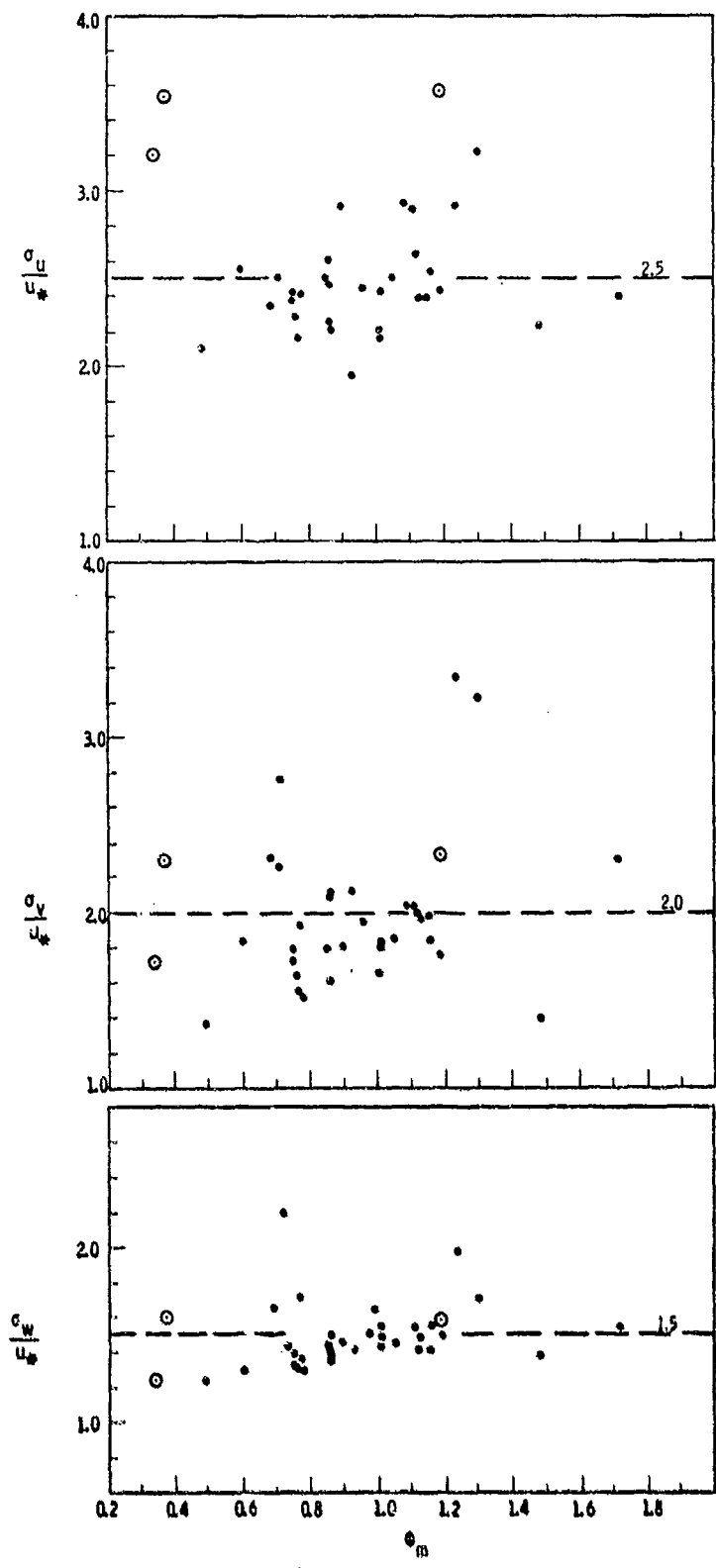

FIGURE 30. Ratios of rms gust velocities to the shear stress as a function of  $\phi_m$  for extended tests at Lake Union.

TABLE 10. INITIAL PARAMETER VALUES FOR THE SPECTRAL MODEL

$\gamma$	$C_\gamma$	$r_\gamma$	$\sigma_\gamma/u_*$	$2\pi C_\gamma/(\sigma_\gamma/u_*)^2$
u	4.8	1	2.5	4.8
v	2.7	1	2.0	4.2
w	0.94	5/3	1.5	2.6

revised values were computed for  $C_\gamma$ . At the same time the length scales which would provide the best fit between the modeled spectra and the data were determined. The initial estimates of the parameter  $r_\gamma$  proved to be satisfactory. Table 11 gives the revised values of the model parameters and best fit length scales.

TABLE 11. REVISED PARAMETER VALUES FOR THE SPECTRAL MODEL

$\gamma$	Height	$C_\gamma$	$r_\gamma$	$2\pi C_\gamma/(\sigma_\gamma/u_*)^2$	$L'_\gamma$
u	6.9	6.4	1	6.4	50
	48.2	6.4	1	6.4	100
v	6.9	3.8	1	6.0	25
	48.2	3.8	1	6.0	50
w	6.9	1.5	5/3	4.3	7
	48.2	1.4	5/3	4.0	20

FINAL SPECTRAL FORMS FOR AERONAUTICAL USE

The parameters in Table 11, in conjunction with Equation (8-3), provide spectral models which are in exceptional agreement with the Lake Union data. However the models are in the frequency domain. A transformation into wave number domain using

$$k = \frac{2\pi n}{\bar{u}} \quad (8.4)$$

provides the turbulence models in terms more familiar to aeronautical users. They are, for the longitudinal and lateral components:

$$\frac{kS_{\gamma}(k)}{\sigma_{\gamma}^2} = \frac{k L'_{\gamma}}{(1 + 1.5 k L'_{\gamma})^{5/3}} \quad \gamma = u, v \quad (8.5)$$

and for the vertical component,

$$\frac{kS_w(k)}{\sigma_w^2} = \frac{2k L'_w}{3[1 + 1.5(k L'_w)^{5/3}]} \quad (8.6)$$

These spectral models are shown in Figure 31.

The next two chapters deal with the parameters of these spectral models. Gust velocities observed during the survey are described and modeled in Chapter 9, and length scales are covered in Chapter 10.

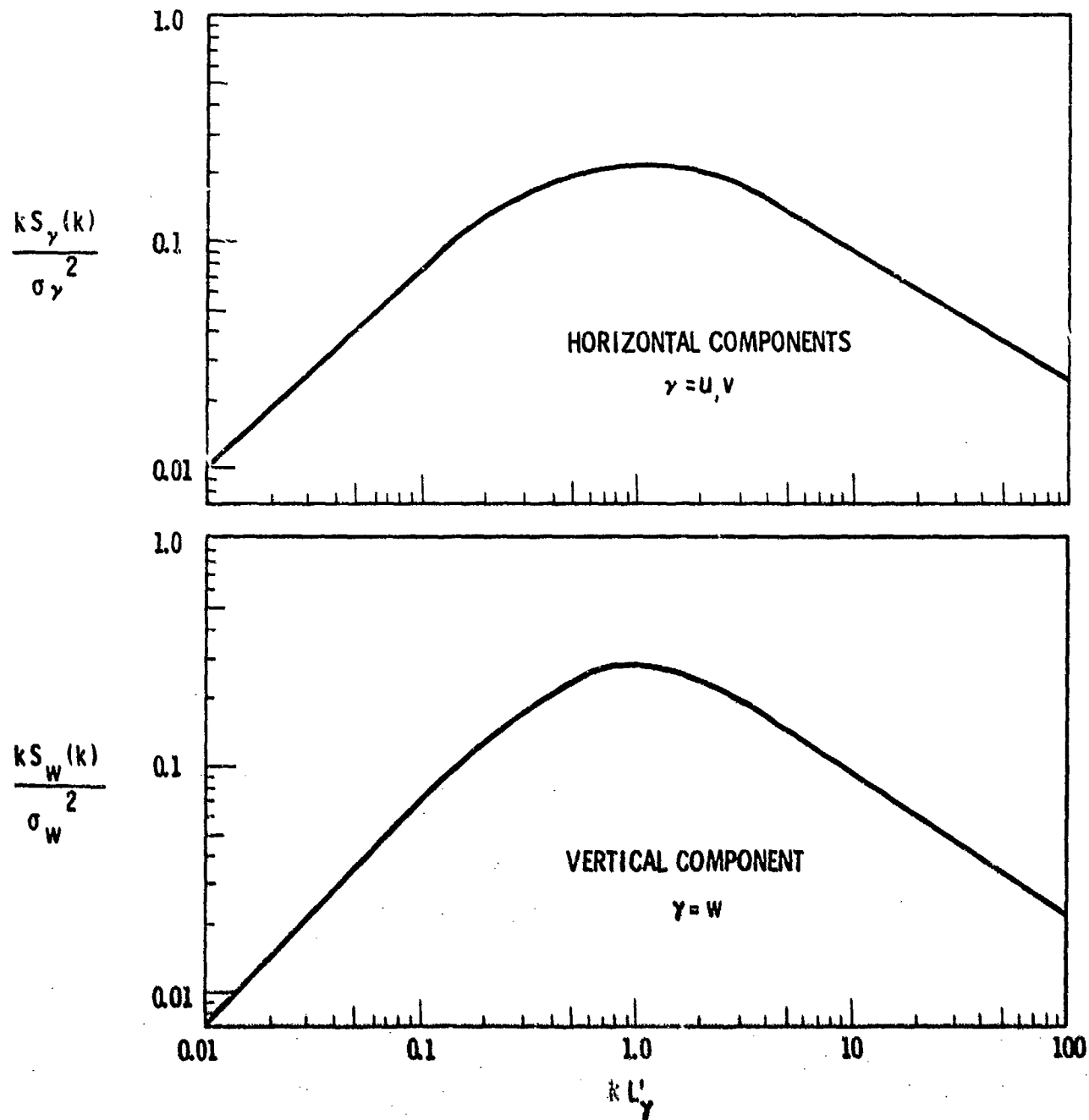

FIGURE 31. Suggested atmospheric spectral models.

## CHAPTER 9

### GUST VELOCITIES

In the last chapter, models were developed to describe the power spectra for each of the wind components. Each model is completely determined by specification of values for two parameters, an rms gust velocity and a turbulence length scale. In this chapter, the gust velocities observed during the survey are described and used to develop a set of gust velocity models. In the next chapter, the survey measurements will be used to develop the length scale models needed to complete the definition of the spectra.

#### OBSERVED RMS GUST VELOCITIES

Cumulative frequency distributions of the longitudinal, lateral and vertical rms gust velocities are shown in Figures 32 through 34, respectively. Data from the three sites are presented on the same figure, but it must be remembered that the data sets for the three sites are not made up of entirely concurrent measurements. In addition, the combination of the data from the KIXI lower level with the nominally 7 m data from Lake Union and SEA-TAC is not truly justifiable if, indeed, the combination of the upper level data is.

Having expressed that caution, it is interesting to note the differences and similarities in the observed distributions. The Interim Report indicated that significantly higher rms gust velocities should be expected in the urban area relative to those at a conventional airport. That is the case for the longitudinal and vertical components although the differences are not as pronounced as expected. The reduction of the

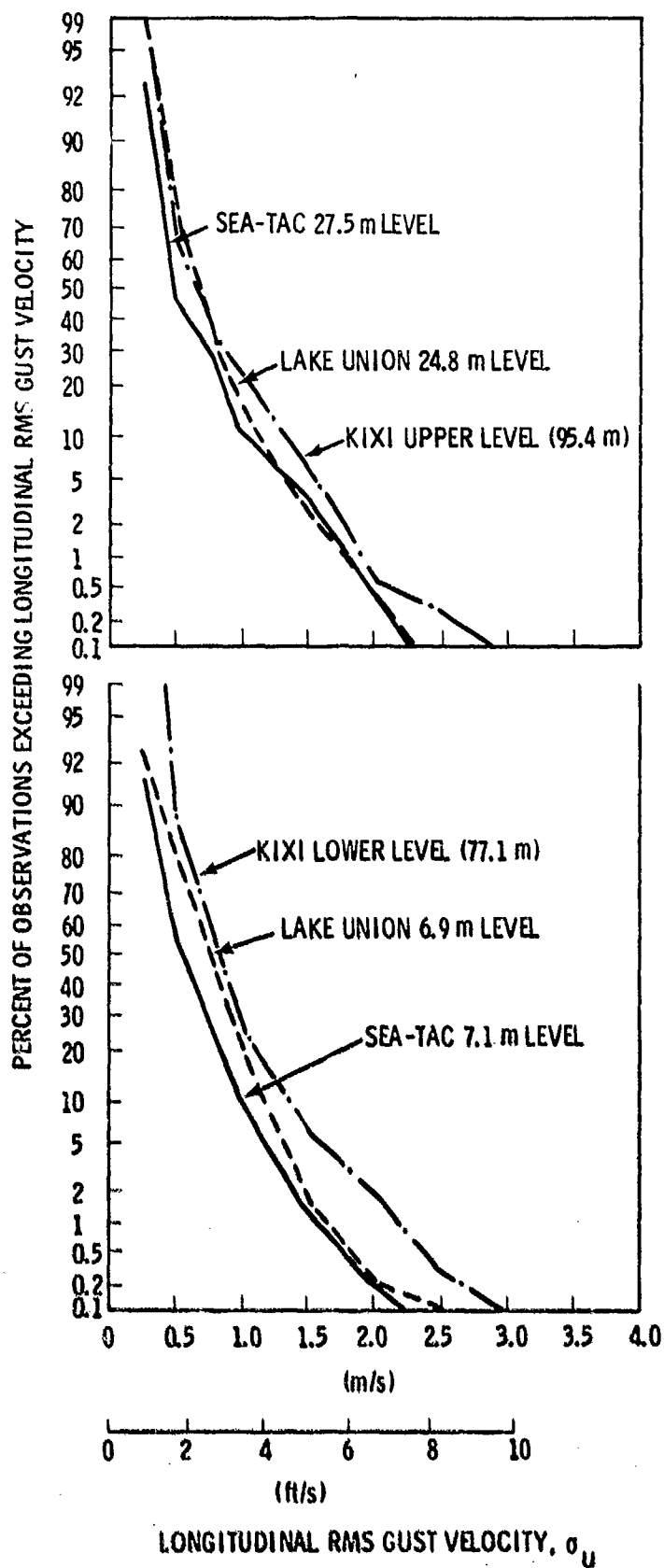

FIGURE 32. Cumulative frequency distributions of observed rms longitudinal gust velocities.

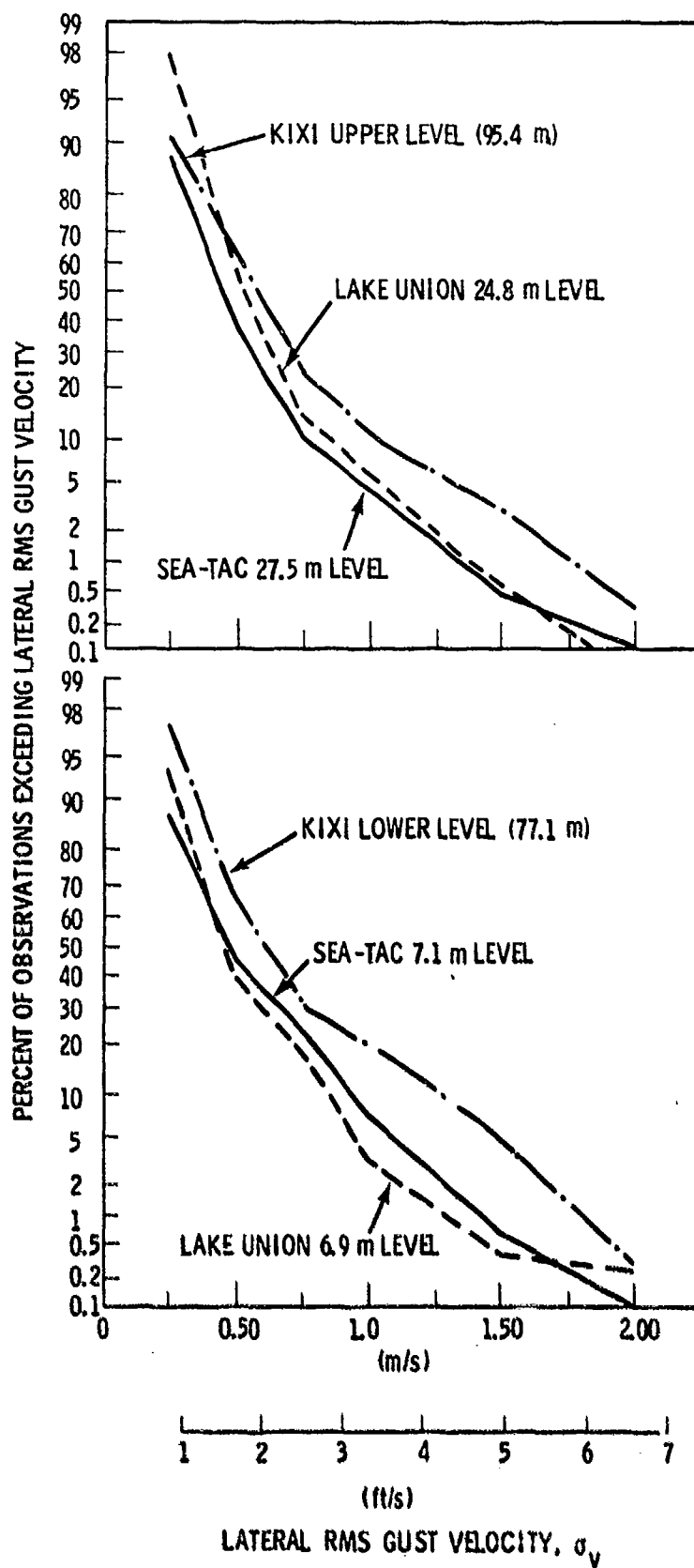

FIGURE 33. Cumulative frequency distributions of observed rms lateral gust velocities.

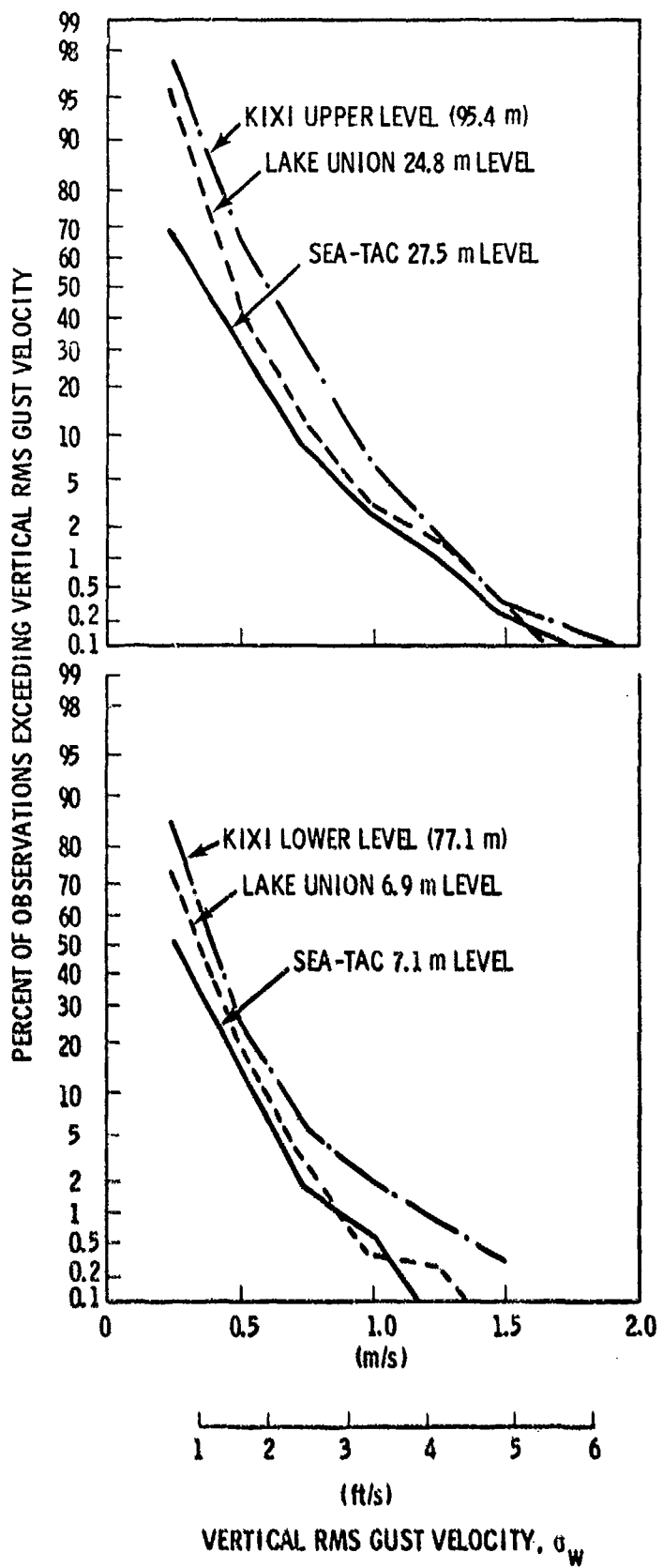

FIGURE 34. Cumulative frequency distributions of observed rms vertical gust velocities.

differences is explained by directional variation of the wind which was not accounted for in the Interim Report. The urban area gust velocities were assumed to be large and those at the airport were assumed to be small for all wind directions. Neither assumption was met at the survey sites. The frequency of large rms gust velocities was considerably smaller in the survey than had been anticipated. This was the result of the low mean wind speed during the survey period. The higher frequencies of large rms gust velocities at KIXI are primarily caused by the higher mean wind speeds at the higher measurement levels.

#### TURBULENCE INTENSITIES

Frequently, rms gust velocities are normalized by the mean wind speed to form turbulence intensities. These intensities tend to become constant as wind speeds increase instead of increasing as the rms gust velocities do. For this reason, average turbulence intensities were summarized and examined as a function of various meteorological and physical factors.

#### Effect of Stability on Turbulence Intensities

The geometric mean of the turbulence intensities between 12.6 and 24.8 m at Lake Union have been plotted as a function of  $\phi_m$  to assist in identification of possible relationships between stability and turbulence intensity. The results are shown in Figure 35. As in the case in which the rms gust velocities were normalized to  $u_*$ , any relationship to stability is lost in the scatter of the data.

#### Effects of Wind Speed, Surface Roughness and Height on Turbulence Intensities

In summarization of the climatological data, geometric mean turbulence intensities were computed for each wind speed

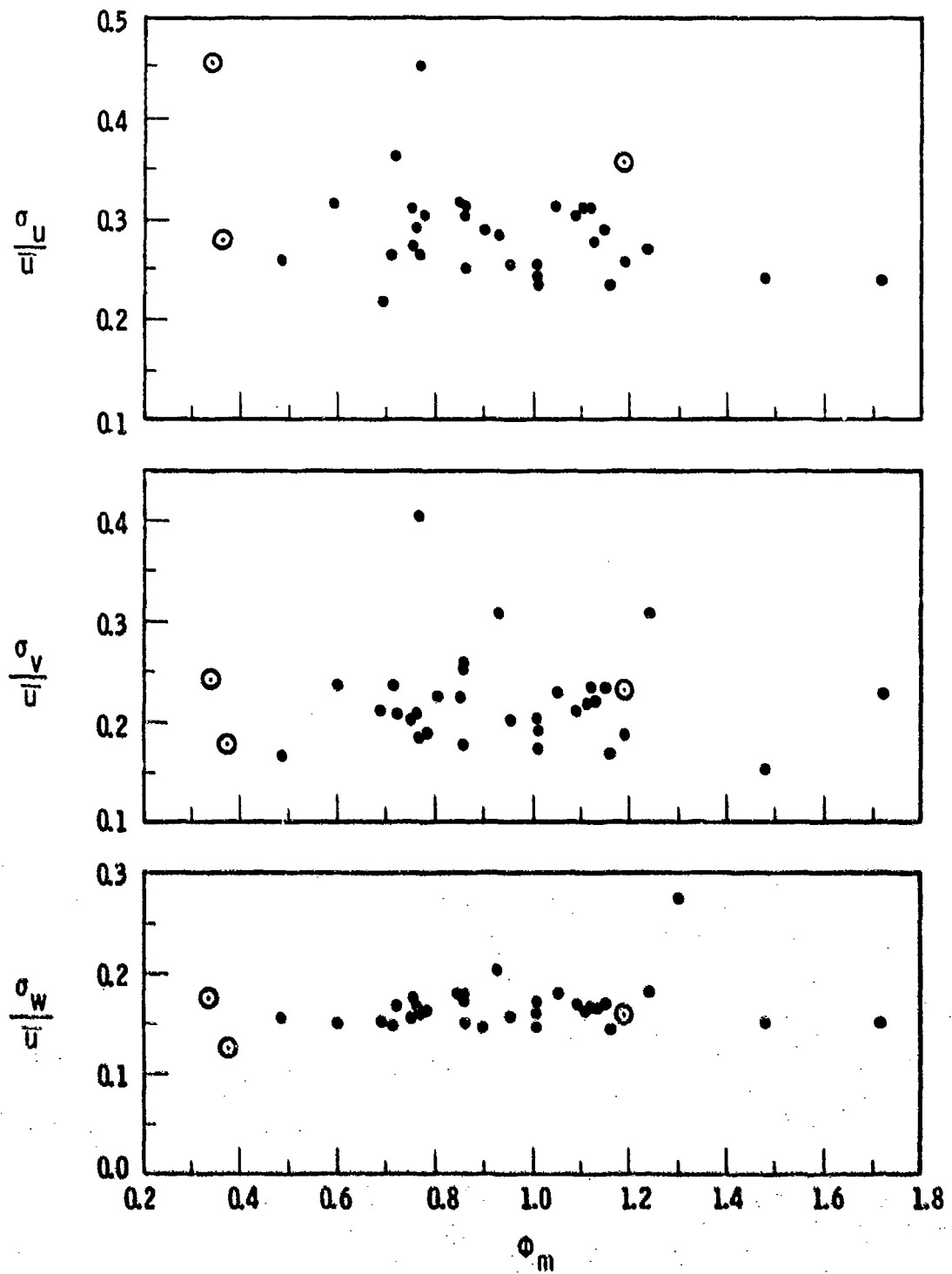

FIGURE 35. Turbulence intensities as a function of  $\phi_m$  for the extended tests at Lake Union.

and direction category at all three survey sites. These data are presented in their entirety in tabular form in Appendix D. Tables 12 and 13 have abstracted a small portion of the data for purposes of the present discussion.

Table 12 presents the average turbulence intensities by wind direction and component for each level at all sites for the 3-5 m/s wind speed class. The underlined values indicate the wind directions in which significant tower effects on wind measurements would be expected. It will be noted that in general these coincide with relatively high turbulence intensities. A prime example of this is found for the u component at KIXI.

Systematic variation of turbulence intensities with direction can be seen at all sites. At Lake Union the turbulence intensities in the sector from WNW through NNW are significantly lower than those found in other sectors, and the highest values are found in the sector from SSE through SSW. This sector contains the major built-up area of the city. Comparison of the turbulence intensities in the southerly sectors at KIXI with those in the northerly sectors again shows the influence of the urban area. It will be noted that the intensities for the upper level in the southern sector at KIXI are considerably larger than those found for the same sector for the Lake Union top level.

The SEA-TAC turbulence intensities also show a marked directional dependence. Those winds having an easterly component arrived at the measurement site having spent a significant period over the flat runway area. As a result the turbulence intensities are relatively low. North and south winds and those having a westerly component were influenced by terrain and vegetation features which were of the same size

TABLE 12. AVERAGE TURBULENCE INTENSITIES BY WIND DIRECTION AND HEIGHT FOR WIND SPEEDS BETWEEN 3 AND 5 M/S

WIND DIRECTION	LAKE UNION				KIXI		SEA-TAC	
	HEIGHT (m)				HEIGHT (m)		HEIGHT (m)	
	6.9	12.6	24.8	48.2	77.1	95.4	7.1	27.5
U COMPONENT								
N	0.27	0.24	0.18	0.17	0.15	0.12	0.22	0.18
NNE	0.28	0.29	0.22	0.17	0.18	0.19	0.21	0.16
NE	0.25	0.23	0.19	0.17	0.20	0.18	0.17	0.12
ENE	0.17*	0.22*	0.18	0.19	0.18	0.20	0.16	0.13
E		0.32*	0.16	0.13*	0.17	0.18	0.18	0.13
ESE		0.24*	0.23*		0.35	0.33	0.15	0.12
SE		0.42*	0.24	0.14	0.19	0.17	0.13	0.11
SSE	0.31*	0.33	0.27	0.24	0.20	0.19	0.16	0.14
S	0.26	0.26	0.23	0.18	0.29	0.28	0.19	0.19
SSW	0.26	0.23	0.22	0.19	0.29	0.28	0.21	0.20
SW	0.24	0.24	0.22	0.17	0.28	0.26	0.22	0.20
WSW	0.25	0.22	0.20	0.17	0.27	0.17	0.23	0.21
W	0.18	0.15*			0.20*		0.24	0.19
WNW	0.21	0.22*	0.14*	0.23*	0.17*	0.21*	0.24	0.19
NW	0.15	0.14	0.16	0.11	0.20	0.19	0.28	0.20
NNW	0.20	0.17	0.12	0.12	0.25	0.20	0.28	0.20
V COMPONENT								
N	0.15	0.11	0.12	0.12	0.12	0.10	0.24	0.18
NNE	0.16	0.16	0.15	0.11	0.14	0.12	0.16	0.12
NE	0.19	0.18	0.15	0.15	0.18	0.15	0.14	0.10
ENE	0.16*	0.17*	0.17	0.16	0.15	0.16	0.13	0.11
E		0.22*	0.21	0.13*	0.14	0.16	0.13	0.10
ESE		0.19*	0.18*		0.28	0.24	0.10	0.08
SE		0.45*	0.18	0.09	0.18	0.15	0.10	0.10
SSE	0.27*	0.29	0.22	0.18	0.17	0.16	0.14	0.11
S	0.22	0.20	0.18	0.17	0.28	0.24	0.17	0.15
SSW	0.22	0.20	0.17	0.16	0.30	0.26	0.20	0.17
SW	0.22	0.22	0.20	0.18	0.23	0.22	0.19	0.17
WSW	0.26	0.18	0.16	0.14	0.23	0.16	0.20	0.17
W	0.17	0.12*			0.22*		0.21	0.20
WNW	0.14	0.15*	0.10*	0.21*	0.18*	0.17*	0.22	0.17
NW	0.12	0.12	0.12	0.11	0.22	0.19	0.25	0.18
NNW	0.12	0.13	0.12	0.10	0.19	0.16	0.23	0.18
W COMPONENT								
N	0.11	0.12	0.11	0.08	0.07	0.11	0.14	0.13
NNE	0.13	0.15	0.15	0.09	0.07	0.13	0.10	0.10
NE	0.14	0.16	0.14	0.11	0.10	0.14	0.08	0.08
ENE	0.12*	0.14	0.14	0.11	0.07	0.13	0.08	0.08
E		0.22*	0.18	0.10*	0.08	0.14	0.07	0.06
ESE		0.20*	0.16*		0.13	0.22	0.05	0.06
SE		0.42*	0.20	0.14	0.11	0.14	0.06	0.08
SSE	0.22*	0.26	0.20	0.14	0.11	0.16	0.08	0.09
S	0.15	0.17	0.17	0.10	0.14	0.22	0.10	0.12
SSW	0.14	0.16	0.16	0.11	0.16	0.23	0.12	0.14
SW	0.14	0.16	0.16	0.12	0.13	0.21	0.12	0.14
WSW	0.16	0.15	0.15	0.12	0.13	0.16	0.14	0.16
W	0.12	0.10*			0.16*		0.12	0.14
WNW	0.08	0.12*	0.12*	0.15*	0.08*	0.13*	0.13	0.14
NW	0.06	0.09	0.11	0.06	0.12	0.19	0.16	0.15
NNW	0.13	0.09	0.09	0.06	0.09	0.17	0.18	0.14

\* AVERAGE OF LESS THAN 5 OBSERVATIONS  
 UNDERLINED VALUES MAY INCLUDE SIGNIFICANT TOWER EFFECTS

TABLE 13. AVERAGE TURBULENCE INTENSITIES BY WIND SPEED AND HEIGHT FOR AIR FLOWING OVER REGIONS OF CONTRASTING ROUGHNESS IN AN URBAN AREA

U (m/s)	z (m)	NORTHWEST			SOUTH		
		$\sigma_u/u$	$\sigma_v/u$	$\sigma_w/u$	$\sigma_u/u$	$\sigma_v/u$	$\sigma_w/u$
<u>LAKE UNION</u>							
3-5	6.9	0.179	0.121	0.072	0.263	0.221	0.149
	12.6	0.156	0.124	0.090	0.246	0.201	0.169
	24.8	0.137	0.118	0.098	0.231	0.181	0.168
	48.2	0.118	0.104	0.058	0.196	0.165	0.114
5-7	6.9	0.155*	0.095*	0.068*	0.252*	0.211*	0.144*
	12.6	0.143*	0.115*	0.077*	0.237	0.196	0.157
	24.8	0.110*	0.083*	0.067*	0.219	0.172	0.155
	48.2	0.113*	0.113*	0.069*	0.201	0.147	0.097
7-9	6.9	0.121**	0.079	0.048**	0.242'	0.265'	0.159'
	12.6	0.138'	0.118'	0.068'	0.232**	0.201**	0.158**
	24.8	0.136*	0.103*	0.080*	0.218*	0.164*	0.151*
	48.2	0.106'	0.093'	0.057'	0.196*	0.132*	0.093*
9-11	6.9	0.121''	0.137''	0.060''	0.284''	0.243''	0.139''
	12.6	-----	-----	-----	0.339''	0.243''	0.188''
	24.8	0.043''	0.078''	0.053''	0.208'	0.170'	0.152'
	48.2	0.170''	0.143''	0.101''	0.197*	0.118''	0.093*
<u>KIXI</u>							
		NORTH			SOUTH		
3-5	77.1	0.177	0.139	0.074	0.251	0.240	0.137
	95.4	0.156	0.114	0.128	0.245	0.215	0.198
5-7	77.1	0.171*	0.128*	0.069*	0.246*	0.223*	0.137*
	95.4	0.136*	0.102*	0.112*	0.244*	0.217*	0.181*
7-9	77.1	0.163*	0.124	0.065*	0.240*	0.231*	0.152*
	95.4	0.138*	0.106*	0.107*	0.248**	0.216**	0.182**
9-11	77.1	0.113''	0.123''	0.067''	0.309''	0.252''	0.181''
	95.4	0.064''	0.054''	0.063	0.269''	0.221''	0.167''

NUMBER OF VALUES AVERAGED

- > 99 NO SUPER SCRIPT
- 20 - 99 \*
- 10 - 19 \*\*
- 05 - 09 '
- < 05 ''

magnitude as the height of the tower. This resulted in turbulence intensities which were approximately the same as those observed for flow over the city.

Table 12 also indicates that, in general, turbulence intensities tend to decrease with height. Theoretically, this is predicted for the neutral boundary layer over homogeneous terrain since  $u_*$  and the ratios of  $\sigma_u$ ,  $\sigma_v$ , and  $\sigma_w$  to  $u_*$  are assumed to be constant. It also follows that the decrease of turbulence intensities should be inversely proportional to the logarithm of height. This prediction is supported by the results described in the following sections.

The directional variation of turbulence intensities in the urban area is examined in more detail in Table 13. In this table, turbulence intensities have been averaged over the three wind direction sectors centered on the indicated directions. In addition the table presents data for higher wind speed classes. The data contained in this table show that turbulence intensities in air flowing over the large urban roughness elements tend to be approximately twice those in air flowing over smooth terrain.

#### RMS GUST VELOCITY MODELS, AVERAGE VALUES

Recently Skibin (1974) has indicated that the variation of lateral gustiness with wind speeds above 2 m/s can be described by a relationship of the form

$$\sigma_\theta = a + b/\bar{u} \quad (9-1)$$

where  $\sigma_\theta$  is the rms wind direction fluctuation and  $a$  and  $b$  are constants. If  $\sigma_\theta$  is expressed in radians, it is reasonable to make the substitution

$$\frac{\sigma_V}{\bar{u}} = \sigma_\theta \quad (9-2)$$

in Equation (9-1) giving

$$\frac{\sigma_V}{\bar{u}} = a + \frac{b}{\bar{u}} \quad (9-3)$$

This relationship shows that as the wind speed increases, the lateral intensity of turbulence approaches the constant value,  $a$ , asymptotically. As Equation (9-3) stands, the evaluation of the constants is relatively difficult. Considerable simplification can be made by solving for gust velocities directly. Equation (9-4) makes this change and generalizes the result to all component rms gust velocities

$$\sigma_\gamma = a_{\gamma\theta} \bar{u} + b_{\gamma\theta} \quad (9-4)$$

This relationship is linear and can easily be checked with the survey data. The constants have been given a subscript  $\gamma$  to indicate that they are a function of component. A second subscript has been added to both the rms gust velocity and the constants to indicate that they are also functions of wind direction (surface roughness).

The data in Appendix E were used to compute the geometric mean rms gust velocities for each component as a function of height and wind speed for sectors of contrasting roughness at each of the sites. In general, the gust velocities did not vary significantly with height within a wind speed category. It was therefore deemed appropriate to form weighted vertical averages of the gust velocities. These average values are

given in Table 14 and plotted in Figure 36. It will be noted that in all cases the linear relationship between the rms gust velocity and wind speed predicted by Equation (9-4) is well satisfied. The separation between the relationships for flow over smooth and rough terrain should also be noted. Finally, in comparing the relationship between rms gust velocities and wind speed for flow over the rough sectors at each site, it should be noted that for each component the largest gust velocities occur at KIXI and the lowest at SEA-TAC. This is intuitively the expected result.

TABLE 14. AVERAGE RMS GUST VELOCITIES FOR FLOW OVER SMOOTH AND ROUGH TERRAIN

	Smooth				Rough			
	Wind Speed (m/s)				Wind Speed (m/s)			
	2	4	6	8	2	4	6	8
<u>Lake Union</u>	WSW--NNW				SSE--SSW			
$\sigma_u$	0.412	0.607	0.847	1.05	0.579	0.947	1.38	1.81
$\sigma_v$	0.354	0.488	0.614	0.761	0.488	0.777	1.11	1.54
$\sigma_w$	0.230	0.334	0.416	0.495	0.393	0.619	0.853	1.14
<u>KIXI</u>	NNW--NNE				SSE--SSW			
$\sigma_u$	0.418	0.680	0.951	1.18	0.648	0.983	1.51	1.83
$\sigma_v$	0.310	0.503	0.692	0.875	0.577	0.923	1.39	1.79
$\sigma_w$	0.250	0.409	0.526	0.696	0.467	0.686	0.961	1.23
<u>SEA-TAC</u>	NE--SSE				SSW--NW			
$\sigma_u$	0.296	0.603	0.960	1.00	0.497	0.858	1.22	1.59
$\sigma_v$	0.255	0.495	0.719	1.00	0.342	0.769	1.09	1.39
$\sigma_w$	0.139	0.339	0.483	0.800	0.308	0.552	0.823	1.20

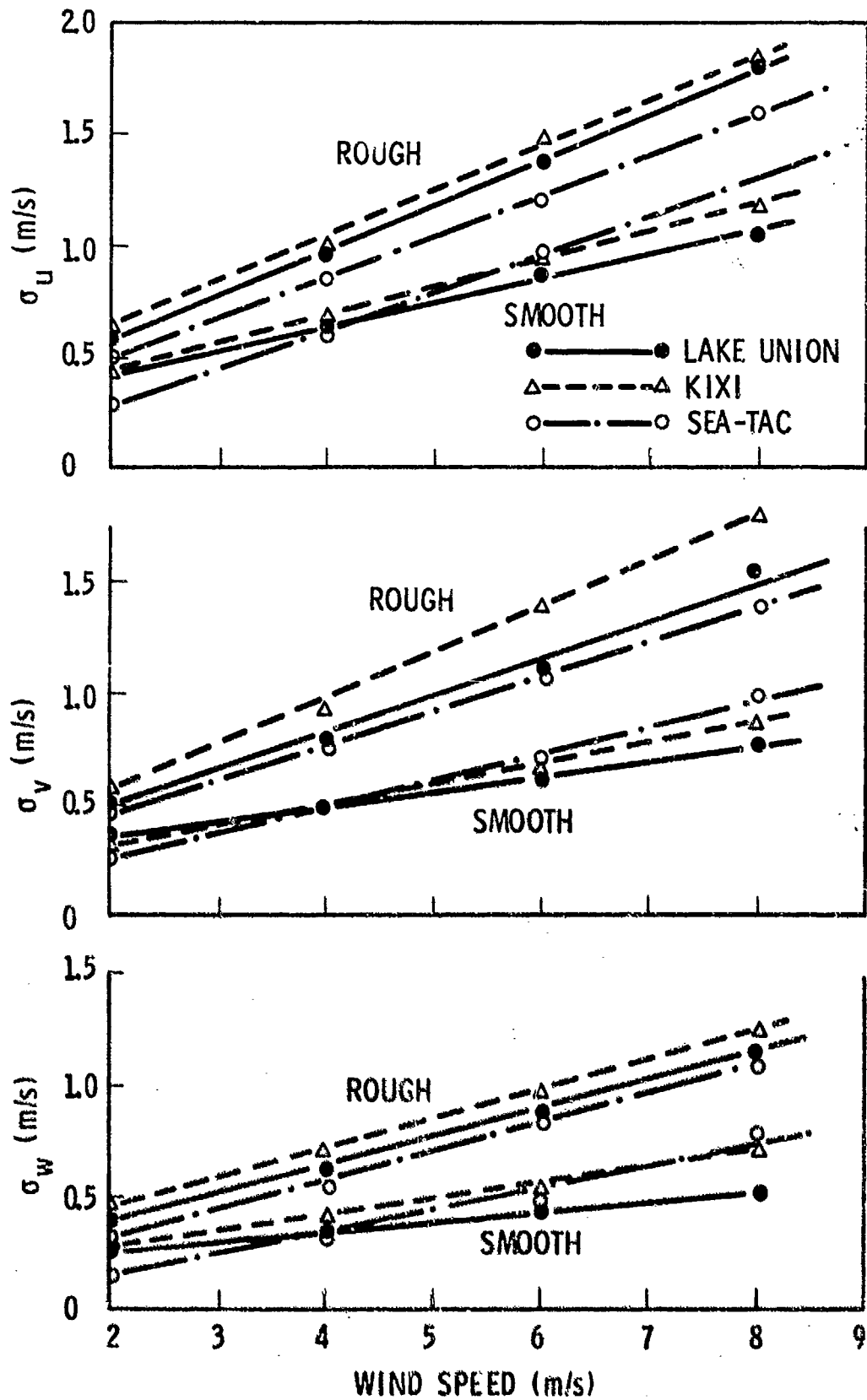

FIGURE 36. Variation of the average rms gust velocities observed for the sectors of contrasting surface roughness at the survey sites.

### Upper Level Gust Velocities Based on Surface Winds

The gust velocity model described by Equation (9-4) assumes that the wind speed is known at the level of interest. That is, if an estimate of the probability of exceeding a given rms gust velocity at 50 m is desired for a particular case, then the wind speed at 50 m must be known. The model can be generalized to compensate for vertical variations in wind speed in the following manner. Restating Equation (9-4)

$$\sigma_Y(z) = a_Y \bar{u}(z) + b_Y \quad ,$$

the rms gust velocity and wind speed are shown explicitly to be a function of the height of measurement of wind speed. Using the logarithmic wind profile, Equation (2-4), the relationship between the wind speed at level  $z$  and that at a reference level  $z_r$  is

$$\bar{u}(z) = \bar{u}_r \frac{\ln(z/z_0)}{\ln(z_r/z_0)} \quad , \quad (9-5)$$

where  $r$  denotes a reference level at which the wind speed is measured and  $z_0$  is the roughness length. This relationship may be used to eliminate  $\bar{u}(z)$  in Equation (9-4), giving

$$\bar{\sigma}_Y(z) = \left[ \frac{a_Y}{\ln(z_r/z_0)} \right] \bar{u}_r \ln\left(\frac{z}{z_0}\right) + b_Y \quad . \quad (9-6)$$

Equation (9-6) provides a means of estimating geometric mean rms gust velocities at any height within the surface boundary layer given the wind speed at one height and knowledge of the surface roughness characteristics. The term in brackets

on the right is a function of wind direction (surface roughness) and stability. If it is assumed that the effects of stability are second-order and negligible in engineering applications, this term should be constant for each site, barring changes in upwind surface roughness.

#### RMS GUST VELOCITY MODELS, FREQUENCY DISTRIBUTIONS

To fully evaluate the significance of a given rms gust velocity, it is necessary to know more than the relationship between the mean gust velocity and wind speed. It is necessary to know the distribution of observed gust velocities about the mean. Figures 32-34 provide an indication that rms gust velocities may be distributed log-normally. This possibility was examined graphically using the survey data.

The distributions of the longitudinal gust velocities during 3-5 m/s winds are shown in Figures 37-39. These figures, which are reasonably representative, indicate that, indeed, the distributions are log-normal. In addition, they indicate that the standard deviations of the distributions are essentially independent of height as long as the same wind speed class is considered at each height. This is evident because there is little difference in the slopes of lines passing through the data points for each height. Other groupings of the data indicate that these standard deviations are, to a first-approximation, independent of wind speed. Similar results were found for the lateral and vertical rms gust velocities.

The probability of exceeding a given rms gust velocity may then be estimated if the wind speed at the level of interest is known. This can be expressed mathematically by

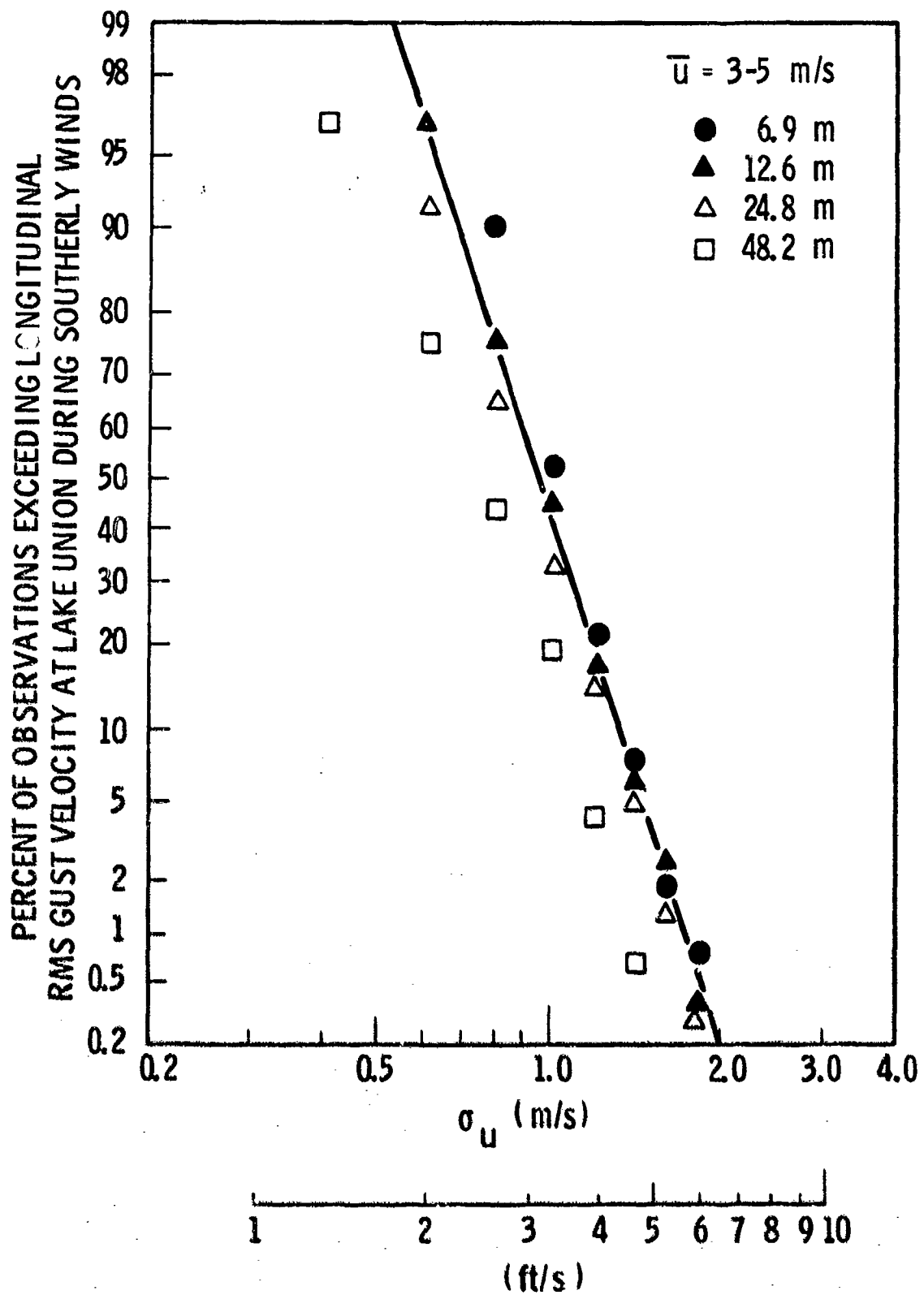

FIGURE 37. Frequency distribution of longitudinal rms gust velocities observed at Lake Union during southerly winds between 3 and 5 m/s.

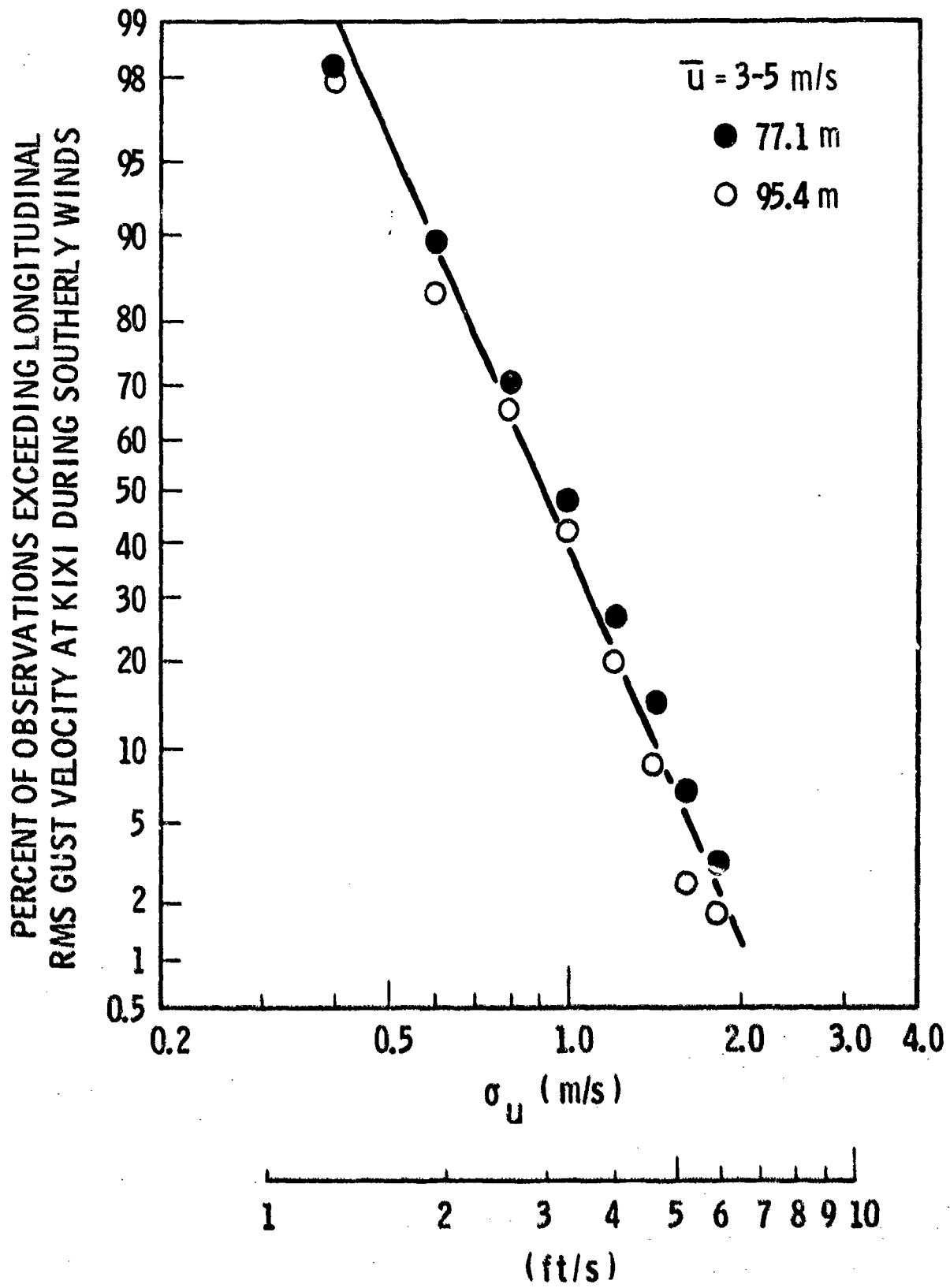

FIGURE 38. Frequency distribution of longitudinal rms gust velocities observed at KIXI during southerly winds between 3 and 5 m/s.

PERCENT OF OBSERVATIONS EXCEEDING LONGITUDINAL  
RMS GUST VELOCITY AT SEA-TAC DURING WEST WINDS

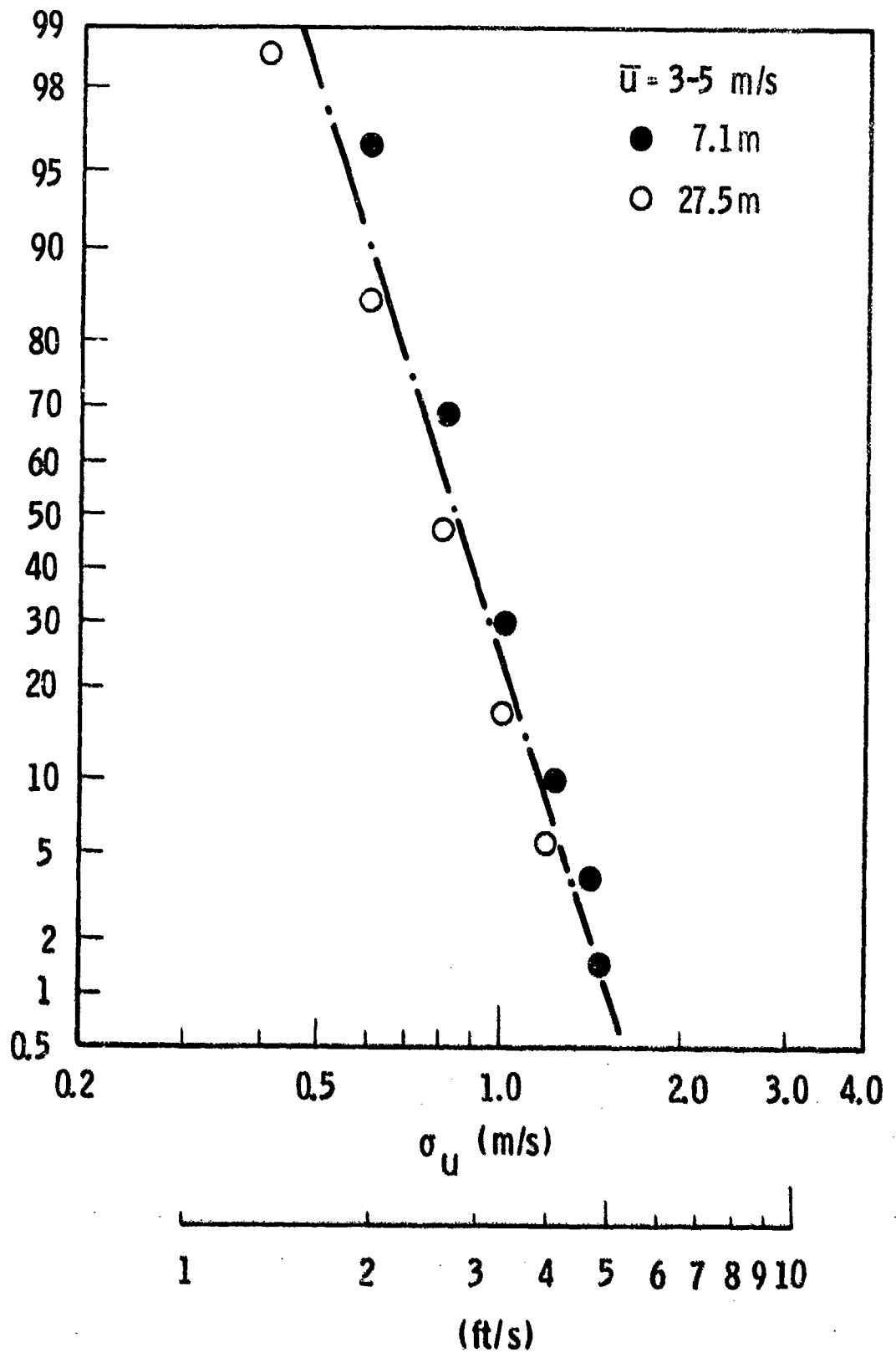

FIGURE 39. Frequency distribution of longitudinal rms gust velocities observed at SEA-TAC during westerly winds between 3 and 5 m/s.

$$P(\sigma_Y > \xi | \bar{u}) = 1 - \frac{1}{\sqrt{2\pi} s_Y} \int_{-\infty}^{\ln \xi} \exp\left\{-1/2\left(\frac{\ln \sigma_Y - \ln \bar{\sigma}_Y}{s_Y}\right)^2\right\} d(\ln \sigma_Y), \quad (9-7)$$

where  $\xi$  is the value to be exceeded,  $\bar{\sigma}_Y$  is the geometric mean estimated by Equation (9-4), and  $s_Y$  is standard deviation of the  $Y$  component rms gust velocity distribution. That is,  $s_Y$  is the standard deviation of the natural logarithms of the observed values of  $\sigma_Y$ . This assumes that the values of  $\sigma_Y$  obtained in different tests with the same mean wind speed may be treated as independent variables. The subscripts indicating directional dependence have been dropped but not forgotten.

Table 15 gives the values of the parameters of Equations (9-4), (9-6) and (9-7), i.e.,  $a_Y$ ,  $b_Y$  and  $s_Y$ . The values of  $a_Y$  and  $b_Y$  can be estimated directly from Figure 36, and for that reason need no further comment. On the other hand, the  $s_Y$  values are not readily ascertainable. These values have been determined by first plotting cumulative distributions on log-normal probability paper as done in Figures 37-39. Then the values of  $s_Y$  are computed by dividing the difference of logarithms of the values of the rms gust velocities at the 16 and 84 percent level by 2.

The values of  $s_Y$  in the table indicate that the distributions of rms gust velocities in an urban area are significantly broader for flow over relatively smooth terrain than they are for flow over rough terrain. In the rural area terrain roughness appears to have little effect on the distribution. The relative contribution of thermal and mechanical factors in generating turbulence may provide the explanation for these differences. In the urban flow over the large roughness elements, the

mechanical generation of turbulence may dominate the thermal generation. In this case the distribution would be relatively narrow. In the flow over relatively smooth terrain less turbulence would be generated mechanically. In this case the thermal properties of the upwind region could significantly enhance or reduce the turbulence level under different conditions. These processes would broaden the distribution of gust velocities beyond that expected for mechanically generated turbulence. Reasons for the relatively constant width of the distribution at the rural site are less easily hypothesized. Perhaps the distribution of rms gust velocities in the smooth sector at the airport is controlled by the roughness of the terminal building on the opposite side of the runway rather than the thermal characteristics of the concrete surface between the terminal and the measurement site.

TABLE 15. PARAMETER VALUES FOR RMS GUST VELOCITY MODELS FOR FLOW OVER ROUGH AND SMOOTH TERRAIN

	Smooth Sector			Rough Sector		
	$a_y$	$b_y$	$s_y$	$a_y$	$b_y$	$s_y$
<u>Lake Union</u>						
$\sigma_u$	0.11	0.20	0.47	0.20	0.17	0.27
$\sigma_v$	0.067	0.22	0.39	0.16	0.17	0.29
$\sigma_w$	0.045	0.16	0.35	0.13	0.13	0.24
<u>KIXI</u>						
$\sigma_u$	0.12	0.19	0.56	0.20	0.25	0.38
$\sigma_v$	0.086	0.14	0.44	0.20	0.17	0.43
$\sigma_w$	0.075	0.10	0.44	0.13	0.19	0.36
<u>SEA-TAC</u>						
$\sigma_u$	0.17	-0.060	0.26	0.18	0.14	0.25
$\sigma_v$	0.11	0.034	0.29	0.15	0.16	0.29
$\sigma_w$	0.092	-0.033	0.21	0.13	0.034	0.21

RMS GUST VELOCITY MODELS FOR URBAN AND RURAL AIRPORTS

Parameter values for the rough sector at Lake Union and KIXI have been averaged to provide a typical set of values for use at urban airports. These values, given in Table 16 are appropriate for airflow across the built-up urban areas. For a realistic contrast, corresponding parameters for flow across a typical rural airport are given in the same table. The differences in the relationship between rms gust velocities and wind speed embodied in the parameter values in this table are shown graphically in Figure 40.

TABLE 16. MODEL PARAMETERS FOR RMS GUST VELOCITY MODELS FOR URBAN AND RURAL AIRPORTS

	Urban Airport			Rural Airport		
	$a_Y$	$b_Y$	$s_Y$	$a_Y$	$b_Y$	$s_Y$
$\sigma_U$	0.20	0.19	0.29	0.17	-0.060	0.26
$\sigma_V$	0.17	0.17	0.31	0.11	0.034	0.29
$\sigma_W$	0.13	0.14	0.26	0.092	-0.033	0.21

Thus, the results of the survey applicable to the evaluation of rms gust velocities and their probability of occurrence at urban and rural airport sites are summarized in Equations (9-7) and (9-4) or (9-6) and Table 16. In the present form the results can easily be programmed for use in V/STOL flight simulation. If these results are to be used for the design of V/STOL aircraft stability and control features or in the determination of airworthiness standards, they may be used with an appropriate wind speed selected from a wind speed distribution such as given in Figure 3-1 in Barr et al. (1974).

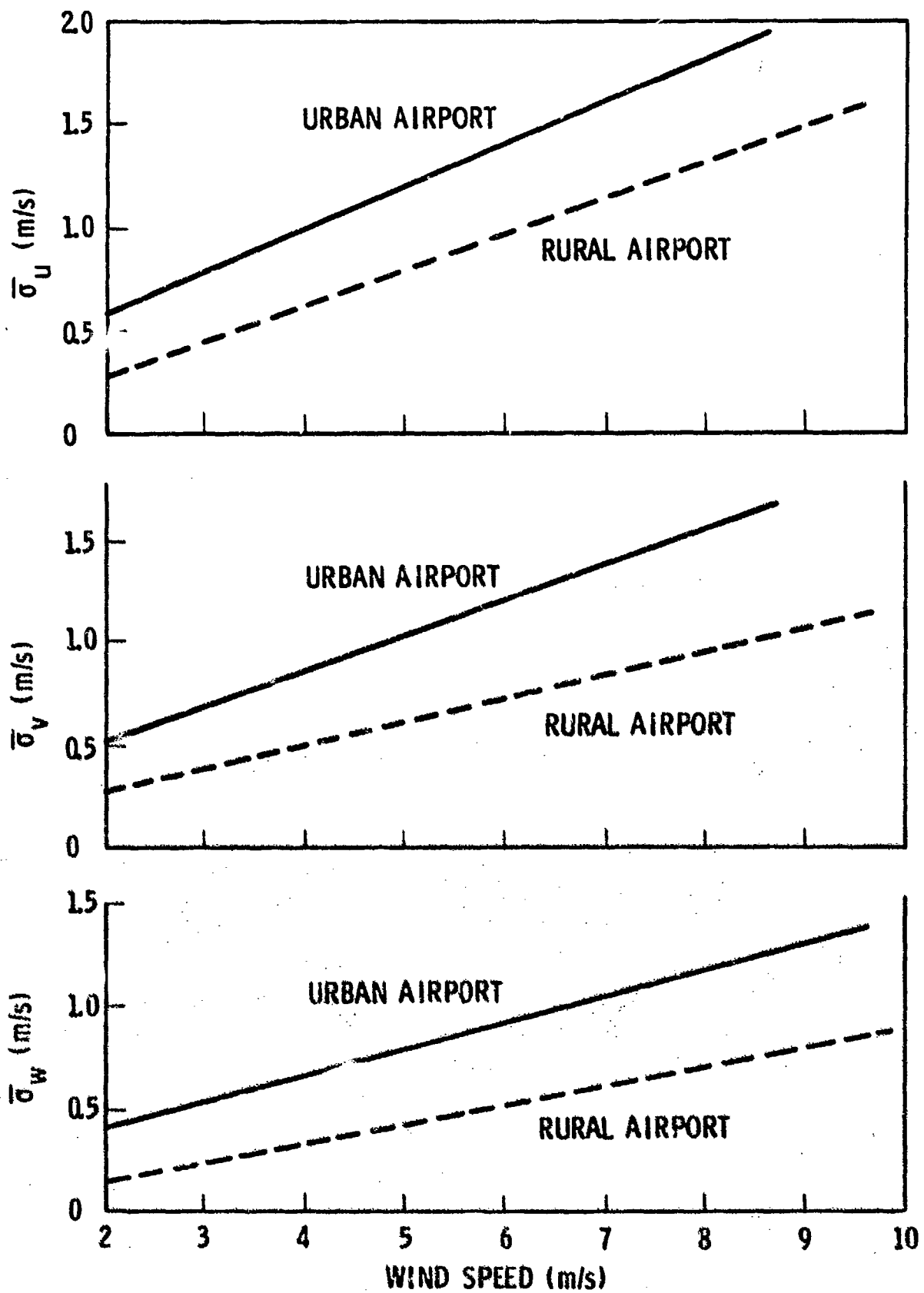

FIGURE 40. RMS gust velocities for typical urban and rural airports.

## CHAPTER 10

### TURBULENCE LENGTH SCALES

The remaining topic in the description of turbulence in urban areas is a discussion of turbulence length scales. Several different length scales can be defined, and two are of particular interest in the present context. These are the length scale associated with the peak of a frequency or wave number multiplied power spectrum [ $nS_Y(n)$  or  $kS_Y(k)$ ] and the integral length scale defined in Equation (2-10). In the development of the urban spectral models [Equation (8-5) and (8-6)] in Chapter 8, these length scales were explicitly assumed to differ by no more than a constant factor,  $A_Y$  [Equation (8-2)]. In this chapter, survey data will be used to examine the variation of the integral length scales at each of the sites. This variation will then be modeled and additional data will be used to provide estimates of the proportionality factor for each component. This last step is particularly significant since the ultimate use of a length scale in application to the simulation of V/STOL aircraft flight is to properly position a power spectrum in wave-number domain. If the spectra are improperly positioned the turbulence generated may be either insignificant or too severe.

Following the development of length scale models, the observed length scales and the models developed from them will be compared with length scales observed at other locations and existing models. Finally, there will be a short section in which survey data are used to examine the isotropic relationships between the rms gust velocities and length scales for the von Karman and Dryden spectral models.

## OBSERVED LENGTH SCALES

During the summary of climatological data, tabulations were made of the distributions of the component integral time scales (length scales divided by the wind speed) for all wind speed classes. From these data tabulations, presented in full in Appendices F and G, Figures 41-43 have been prepared to examine the length scale distributions.

Remembering the cautionary note on comparing observed frequency distributions between sites, the resemblance between the respective distributions at Lake Union and SEA-TAC shown in these figures is striking. This indicates that there is little difference in length scales at the two sites. A second potentially significant feature is the manner in which differences between length scale distributions for the lower instrument at KIXI and those for the 7 m level at Lake Union and SEA-TAC are reduced in the comparison of upper level length scales. They are negligible in the upper level comparison of the horizontal components and are significantly reduced for the vertical component.

### Effects of Atmospheric Stability

As with turbulence intensities, length scales computed from the intensive measurement program at Lake Union were examined to identify possible effects of stability. The geometric mean length scale for each component was computed from the measured values at 12.6 and 24.8 m. These values were then plotted against  $\phi_m$ , resulting in Figure 44. As no  $\phi_m$  dependence was readily apparent, no further efforts were made to classify length scales by stability.

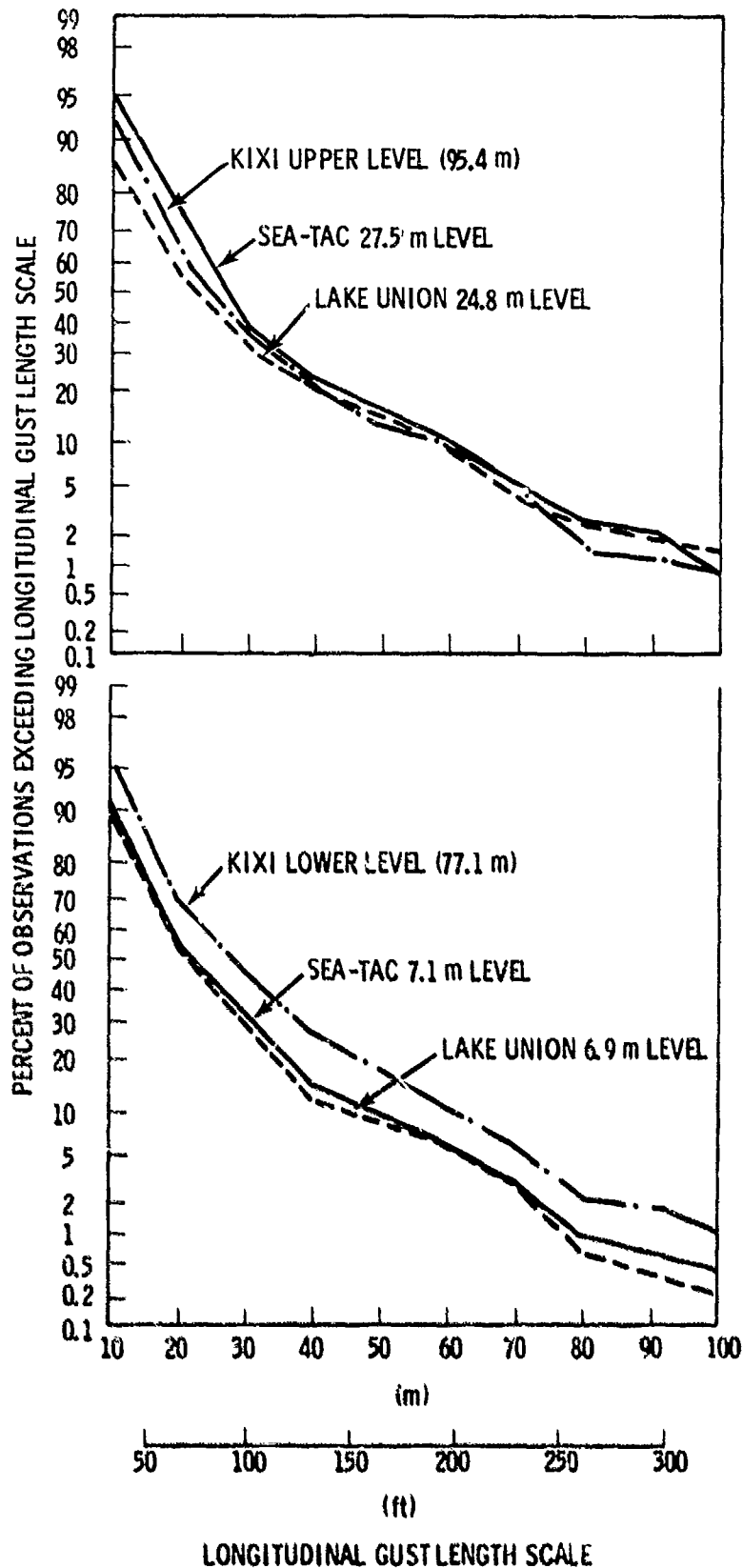

FIGURE 41. Cumulative frequency distributions of observed longitudinal gust length scales.

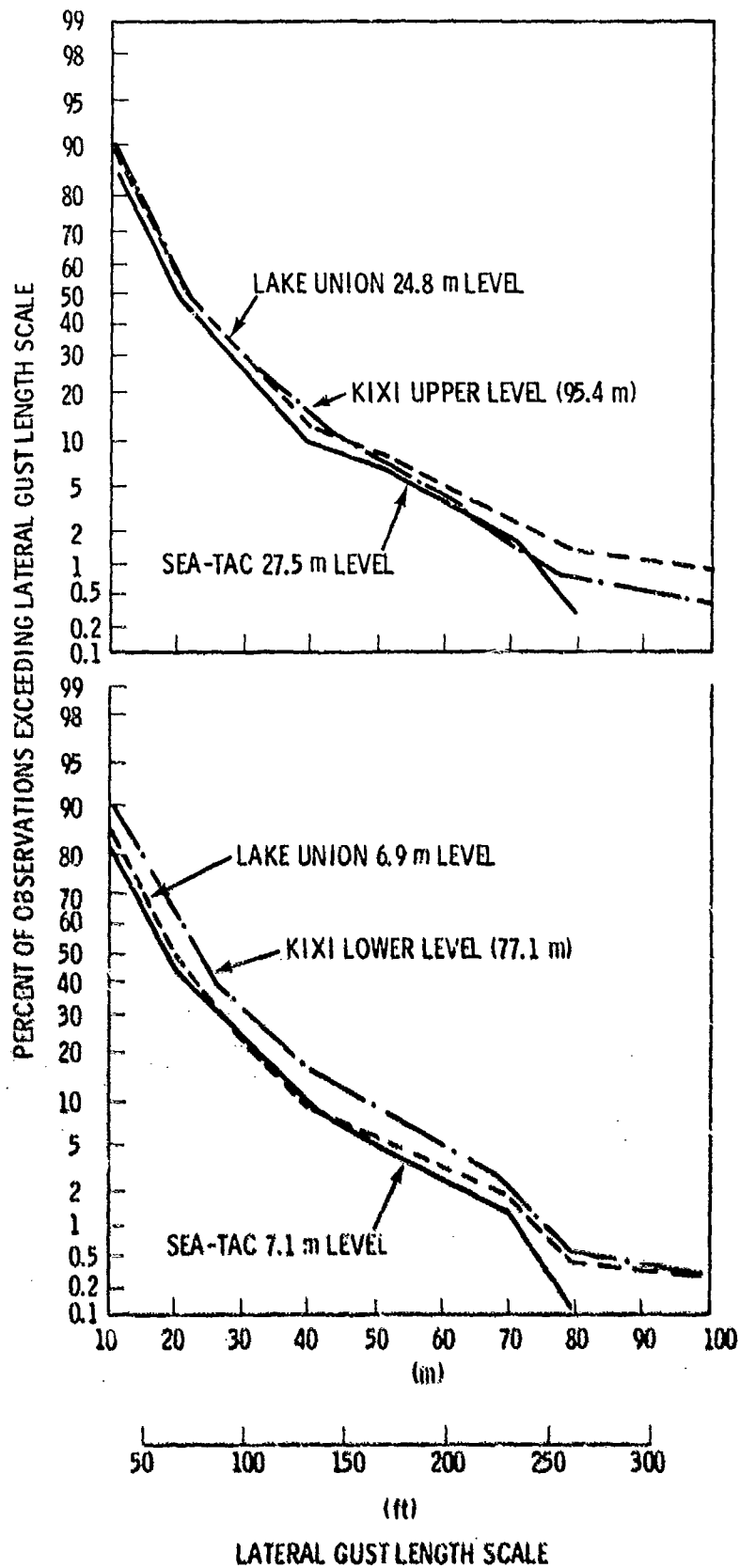

FIGURE 42. Cumulative frequency distributions of observed lateral gust length scales.

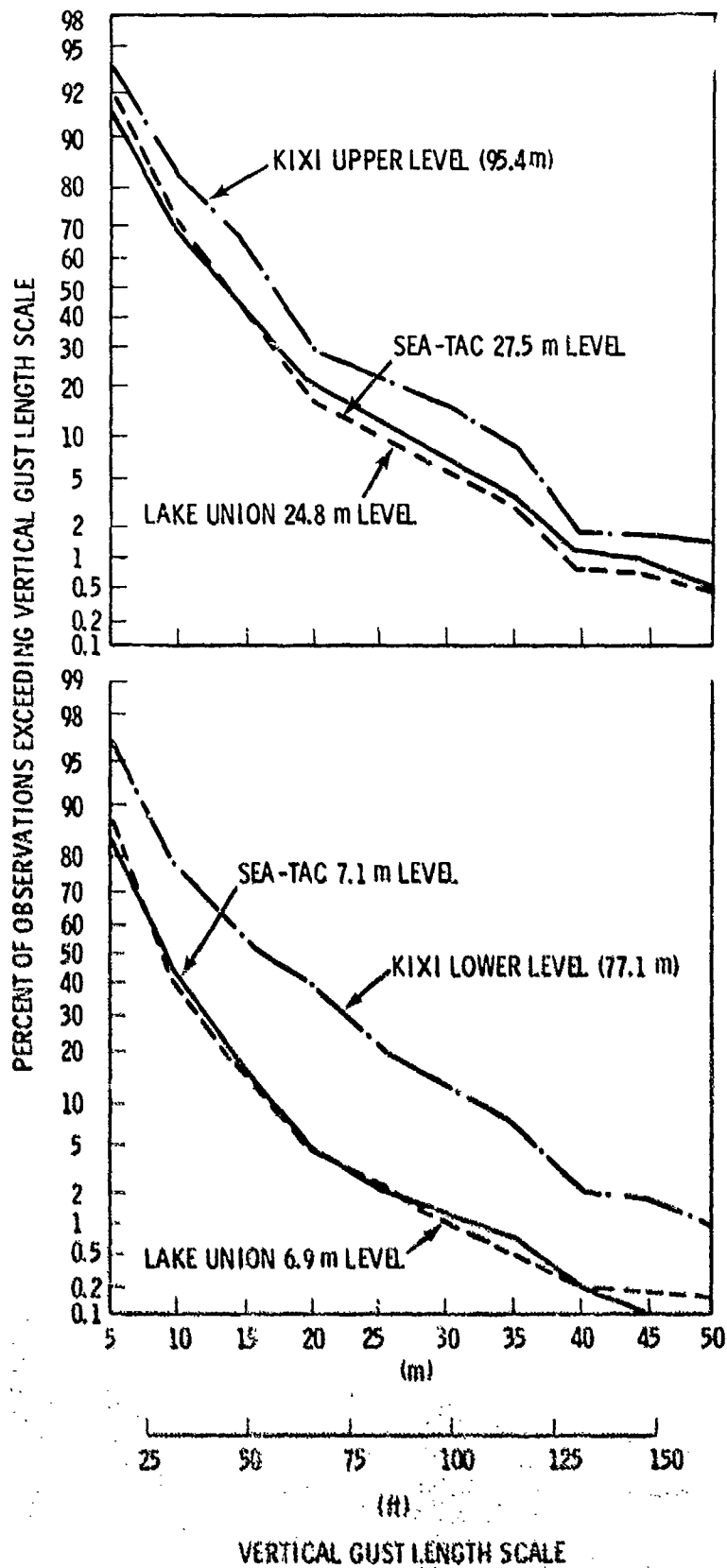

FIGURE 43. Cumulative frequency distributions of observed vertical gust length scales.

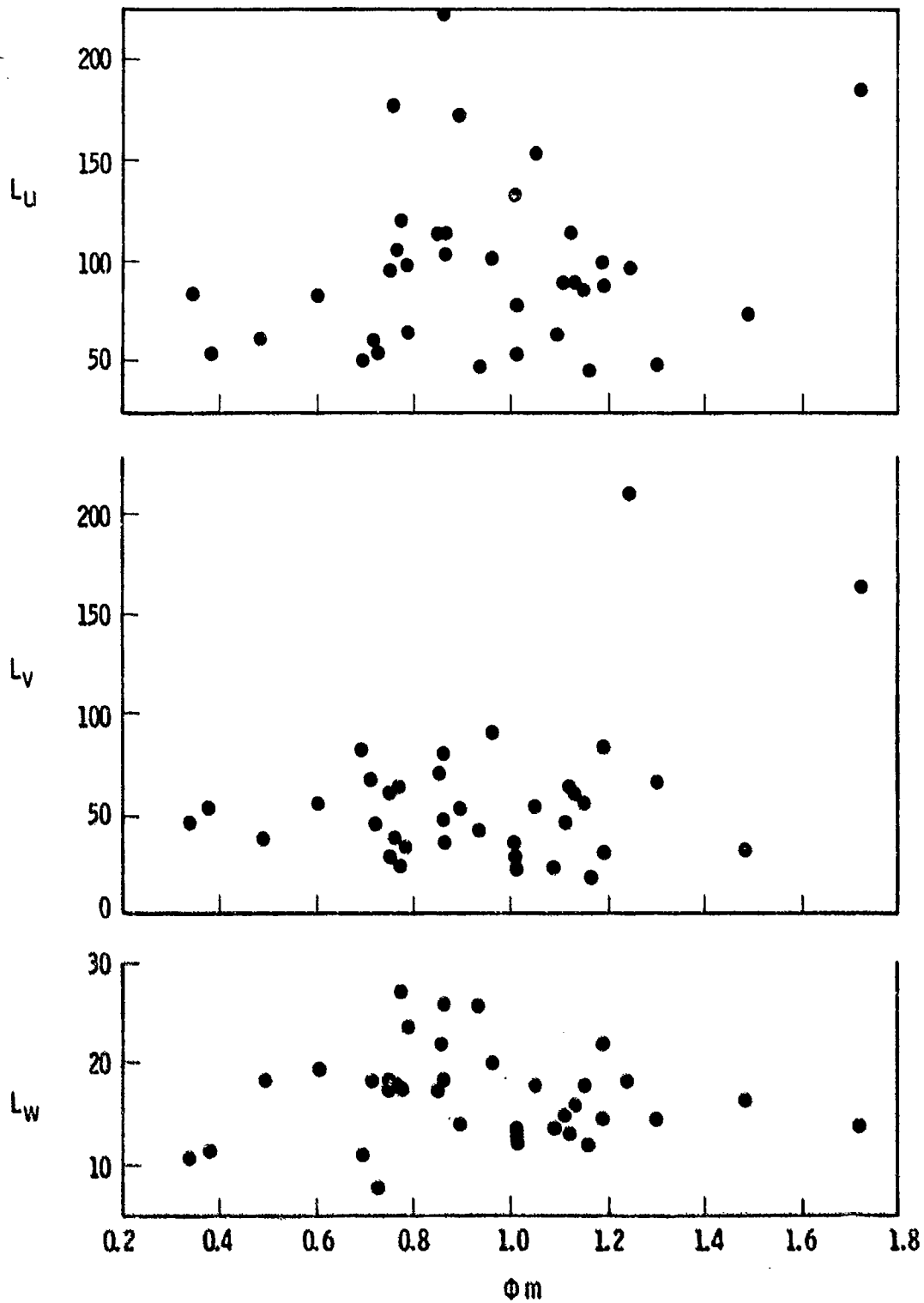

FIGURE 44. Integral length scales as a function of  $\phi_m$  for the extended tests at Lake Union.

## Effects of Wind Speed, Direction and Height

During summarization of the climatological data, average length scales were computed for each component for each wind direction and speed category. A complete tabulation of these values for the survey sites is contained in Appendix F. Table 17 has been abstracted from the data in that appendix.

Table 17 is similar to Table 12 in that the average length scales for each component are presented as a function of wind direction and height. The wind speed at the height of measurement was in all cases in the 3-5 m/s class. This last point is important and will be developed further. Examining the data in the table there are no systematic directional changes in length scale as were apparent for the turbulence intensities. In addition, comparison of the average length scales between heights and sites indicates few differences - the only noticeable difference occurring in the average vertical length scale. These results were puzzling.

Evidence was sought for a directional variation in length scales at Lake Union and KIXI by examining those sectors which should have shown the greatest differences as was done for turbulence intensities. The resulting tabulation of the data is contained in Table 18. Significant directional variation was not found. However, examination of the data in the table indicates that at any given height the horizontal length scales tend to increase with increasing wind speed. This was the second unexpected finding with respect to length scales. These results will be examined in more detail in the following section in which length scale models will be developed.

Prior to accepting the actual magnitudes of the length scales shown in Tables 17 and 18 or Figures 41-43, the data in

TABLE 17. AVERAGE LENGTH SCALES IN METERS BY WIND DIRECTION AND HEIGHT FOR WIND SPEEDS BETWEEN 3 AND 5 M/S

WIND DIRECTION	LAKE UNION				SEA-TAC		KIXI	
	HEIGHT (m)				HEIGHT (m)		HEIGHT (m)	
	6.9	12.6	24.8	48.2	7.1	27.5	77.1	95.4
	U COMPONENT							
N	31.3	30.1	32.1	34.5	33.6	33.4	38.1	35.8
NNE	30.6	39.4	38.1	35.5	26.9	36.4	35.4	29.0
NE	27.7	32.6	37.1	33.9	30.7	31.5	33.2	26.8
ENE	13.5*	24.1*	31.2	36.0	23.1*	23.8	29.3	35.0
E		25.6*	28.7	17.0*	36.4*	35.6*	47.9*	51.0*
ESE		31.5*	30.9*		26.8*	16.4*		70.8*
SE		21.6*	32.5	62.2	39.5*	24.6	36.6	31.9
SSE	22.7*	29.8	40.7	37.4	26.6	33.5	39.3	32.8
S	34.2	38.7	41.5	44.8	34.3	32.9	42.6	37.6
SSW	35.2	38.0	41.6	47.9	33.8	36.2	36.3	37.9
SW	34.9	41.4	40.0	41.8	33.7	37.0	39.4	37.6
WSW	25.8	33.1	38.9	42.4	27.3	33.6	18.8	26.6
W	36.3	40.3*			26.6	27.9	14.6*	
WNW	48.2	32.4*	37.7*	48.6*	29.8	34.5	16.3*	14.5*
NW	41.6	42.9	35.8	38.3	30.2	35.2	34.9*	41.8
NNW	41.3	37.0	38.1	38.8	22.8	30.3	45.9	43.6
ALL DIRECTIONS	37.5	37.8	38.8	40.6	31.3	34.2	38.1	35.9
	V COMPONENT							
N	36.0	28.1	29.7	30.1	26.7	25.6	29.4	30.3
NNE	29.2	31.6	28.8	35.5	24.2	24.7	26.1	22.6
NE	25.5	25.0	29.2	26.7	23.9	24.4	26.2	20.5
ENE	11.0*	18.8*	16.8	24.8	27.5*	24.0	28.5	24.3
E		6.8*	30.4	16.6*	14.4*	27.7*	35.0*	37.7*
ESE		20.8*	13.2*		19.4*	11.0*		22.1*
SE		32.1*	23.3	23.3	27.6*	17.9	24.5	26.8
SSE	16.2*	16.3	30.7	26.8	22.1	22.4	30.5	26.4
S	25.9	25.7	27.9	37.8	25.9	23.7	31.0	26.8
SSW	30.8	30.3	29.9	32.5	28.0	25.1	31.0	28.3
SW	28.8	31.4	32.6	37.5	26.3	26.5	33.2	30.2
WSW	24.0	25.2	26.3	25.6	26.7	28.7	35.9*	39.7
W	34.0	26.5*			30.9	41.8	14.5*	
WNW	46.1	19.4*	18.7*	19.3*	26.5	25.7	18.8*	14.0*
NW	37.4	33.8	21.2	32.7	22.9	23.7	50.6*	46.3
NNW	29.8	30.1	28.7	28.0	26.4	23.0	29.5	32.0
ALL DIRECTIONS	29.8	28.7	28.3	31.2	25.8	25.2	29.9	28.1
	W COMPONENT							
N	19.8	14.1	17.1	22.2	11.1	14.3	22.4	23.4
NNE	11.3	14.9	16.7	24.3	11.2	15.9	24.9	20.2
NE	8.4	11.6	16.2	20.2	10.6	19.1	18.5	15.6
ENE	4.3*	17.0*	15.1	25.6	7.9*	12.8	18.9	16.1
E		10.5*	26.7	10.9*	8.7*	19.9*	16.9*	30.7*
ESE		13.7*	14.5*		7.0*	11.2*		31.2*
SE		6.8*	15.0	40.3	11.0*	12.5	25.1	27.3
SSE	8.4*	12.2	14.8	23.0	10.2	13.3	23.6	27.1
S	10.8	13.5	17.5	26.6	11.9	15.6	22.4	27.0
SSW	10.6	13.5	17.9	29.9	13.1	18.7	24.1	26.8
SW	10.6	13.1	14.6	34.0	11.3	19.6	19.7	21.0
WSW	7.5	10.0	16.7	28.9	12.1	19.4	14.8*	24.5
W	14.0	11.3*			14.0	18.9	14.0*	
WNW	14.3	12.3*	15.9*	23.6*	12.4	20.2	11.0*	17.5*
NW	11.2	17.9	22.5	26.7	11.4	23.9	34.9*	32.5
NNW	15.8	16.2	20.3	24.6	11.6	16.0	30.0	27.6
ALL DIRECTIONS	11.7	14.0	17.6	26.4	11.6	17.4	23.2	24.7

\* AVERAGE OF LESS THAN 9 OBSERVATIONS

TABLE 18. AVERAGE LENGTH SCALES IN METERS BY WIND SPEED AND HEIGHT FOR AIRFLOW OVER REGIONS OF CONTRASTING ROUGHNESS

$\bar{u}$ (m/s)	z (m)	Northwest			South		
		$L_u$	$L_v$	$L_w$	$L_u$	$L_v$	$L_w$
<u>LAKE UNION</u>							
3-5	6.9	42	33	14	34	28	11
	12.6	40*	32*	17*	38	28	14
	24.8	37	26	21	42	29	17
	48.2	39	29	25	45	29	28
5-7	6.9	54*	46*	23*	42*	32*	11*
	12.6	57*	48*	23*	50*	34*	15*
	24.8	43*	37*	19*	54	35	18
	48.2	56*	39*	34*	60	35	24
7-9	6.9	60**	46**	16**	38''	62''	10''
	12.6	64'	76'	21'	42**	42**	16**
	24.8	86**	68**	24**	68*	35*	22*
	48.2	63'	50'	28'	73*	36*	23*
9-11	6.9	58''	111''	9'	57''	62''	10''
	12.6	--	--	--	102''	50''	12''
	24.8	63''	126''	63''	60'	53'	20'
	48.2	48''	31''	45''	94*	52*	32*
<u>KIXI</u>							
		North			South		
3-5	77.1	39*	28*	25*	39	31	23
	95.4	37*	29*	24*	36	27	27
5-7	77.1	56*	37*	26*	49*	35*	24*
	95.4	49*	41*	28*	45*	32*	28*
7-9	77.1	56**	50**	33**	46*	36*	18*
	95.4	68'	70'	29*	51'	40'	26'
9-11	77.1	53''	56''	25''	56''	34''	16''
	95.4	52''	47''	32''	--	--	--

> 99 observations no superscript  
 20 - 99 observations \*  
 10 - 19 observations \*\*  
 5 - 9 observations '  
 < 5 observations ''

Table 9 should be reviewed. In addition, the discussion on length scales which follows should be read. It is evident that a correction factor between 1 and 2 should be applied to the tabulated values, but the actual factor to be used may be a function of the ultimate use of the data.

#### LENGTH SCALE MODELS, AVERAGE VALUES

In the previous section, two interesting features concerning the behavior of the horizontal length scales were noted. These features were the increasing length scale with increasing wind speed and the constancy of the length scale with height when individual wind speed categories were examined. These features were not reflected in existing length scale models. As a result, the survey length scale data have been used to develop a new set of length scale models which properly account for both characteristics.

To set the stage for the development of these models, Equations (2-4), (2-9), and (2-10) are restated

$$\bar{u}_Y = \frac{u_*}{\kappa} \ln \frac{z}{z_0} \quad , \quad (2-4)$$

$$\tau_Y = \int_0^{\infty} R(t) dt \quad , \quad (2-9)$$

and

$$L_Y = \bar{u} \tau_Y \quad . \quad (2-10)$$

These equations are: the logarithmic wind profile for neutrally stratified atmospheric boundary layers; the definition

of the integral time scale for each component; and the relationship between the integral time scale and the integral length scale under Taylor's hypothesis.

Data collected during the survey and in most ground based meteorological measurement programs are wind speed time series. The mean wind speed and the time scales may be calculated from these series without the need for an assumption relating the temporal and spatial characteristics of the wind. Thus, time scales should be examined in any basic modeling attempt.

Length scales were examined in the previous section for directional variation by wind speed classes. In essence this was equivalent to examining the time scales for directional dependence. Having found none, the data for all directions were combined and average time scales were computed for each height and wind speed category. The resulting averages, which are presented in Table 19, form the basic data set used in the length scale model development.

In perusal of the data in this table several salient facts should be noted.

- The time scales for the horizontal components behave in a similar fashion.
- The time scale for the vertical component behaves differently than the horizontal time scales.
- The magnitude of horizontal time scales is essentially the same for all sites within a wind speed category.
- The horizontal time scales within a wind speed category do not change significantly with height.
- The horizontal time scales decrease slowly with increasing wind speed.

TABLE 19. THE VARIATION OF INTEGRAL TIME SCALES WITH HEIGHT AND WIND SPEED

Site	Height	Mean Wind Speed						
		0.75	2.0	4.0	6.0	8.0	10.0	12.0
<u>u Component</u>								
Lake Union	6.9	12.0	10.0	8.9	7.9	6.9*	5.8*	--
	12.6	12.0	10.0	9.4	8.8	6.5	10.0*	5.5*
	24.8	13.0	11.0	10.0	8.8	8.9	6.1*	13.0*
	48.2	13.0	11.0	10.0	10.0	9.0	9.2	10.0*
KIXI	77.1	12.0	11.0	9.5	9.2	6.3	5.4*	--
	95.4	12.0	10.0	9.0	7.8	7.5*	5.2*	--
SEA-TAC	7.1	11.0	9.2	7.8	7.9	6.1*	4.2*	--
	27.0	9.2	9.4	8.6	8.2	7.7	7.4	--
<u>v Component</u>								
Lake Union	6.9	12.0	9.2	7.4	6.4	6.2*	8.6*	--
	12.6	11.0	8.8	7.2	6.4	6.6	5.0*	3.5*
	24.8	12.0	9.2	7.1	6.4	5.2	6.9*	3.0*
	48.2	13.0	10.0	7.8	6.0	4.6	5.2	8.9*
KIXI	77.1	8.7	9.1	7.4	6.3	5.4	4.7*	--
	95.4	10.0	9.1	7.0	6.3	7.0*	4.7*	--
SEA-TAC	7.1	9.3	8.0	6.4	5.5	5.7*	6.3*	--
	27.0	12.0	8.2	6.3	5.4	4.3	4.4*	--
<u>w Component</u>								
Lake Union	6.9	6.0	4.2	2.9	2.6	1.8*	1.0*	--
	12.6	7.7	5.4	3.5	2.9	2.2	1.2*	2.4*
	24.8	8.7	6.4	4.4	3.2	2.8	3.0*	2.0
	48.2	9.6	8.7	6.6	4.3	3.0	3.3	3.5*
KIXI	77.1	7.0	6.9	5.8	4.1	2.9	2.1*	--
	95.4	10.0	8.4	6.2	4.7	3.4*	3.2*	--
SEA-TAC	7.1	4.0	3.9	2.9	2.3	2.1*	1.2*	--
	27.0	6.4	5.8	4.3	3.3	3.1	3.1*	--

Average of less than 20 observations.

- The vertical time scales increase with height.
- The vertical time scales decrease rapidly with increasing wind speed.

These facts make it plain that the horizontal and vertical length scales should be modeled separately.

#### Horizontal Component Length Scales

The horizontal velocity component length scale behavior is less complicated and is therefore modeled first.

The observations made with respect to the horizontal time scales indicate that they are not directly related to height and that they are only weakly related to wind speed. The relationship between these time scales and height is qualified because in the atmospheric boundary layer the wind speed does not remain constant with height. To examine the relationship between wind speed and these time scales, averaged component time scale data from Table 19 were plotted against the mean speed category. Figure 45 resulted. The bars through the points indicate the range of values in Table 19.

The wind speed axis represents the wind speed at the actual level of measurement. The relationship between the time scales and wind speed can be well represented in both cases by the form

$$\tau_Y(z) = B_Y \bar{u}(z)^{c_Y}$$

$$Y = u, v \quad (10-1)$$

where  $B_Y$  and  $c_Y$  are slightly different for the two components.

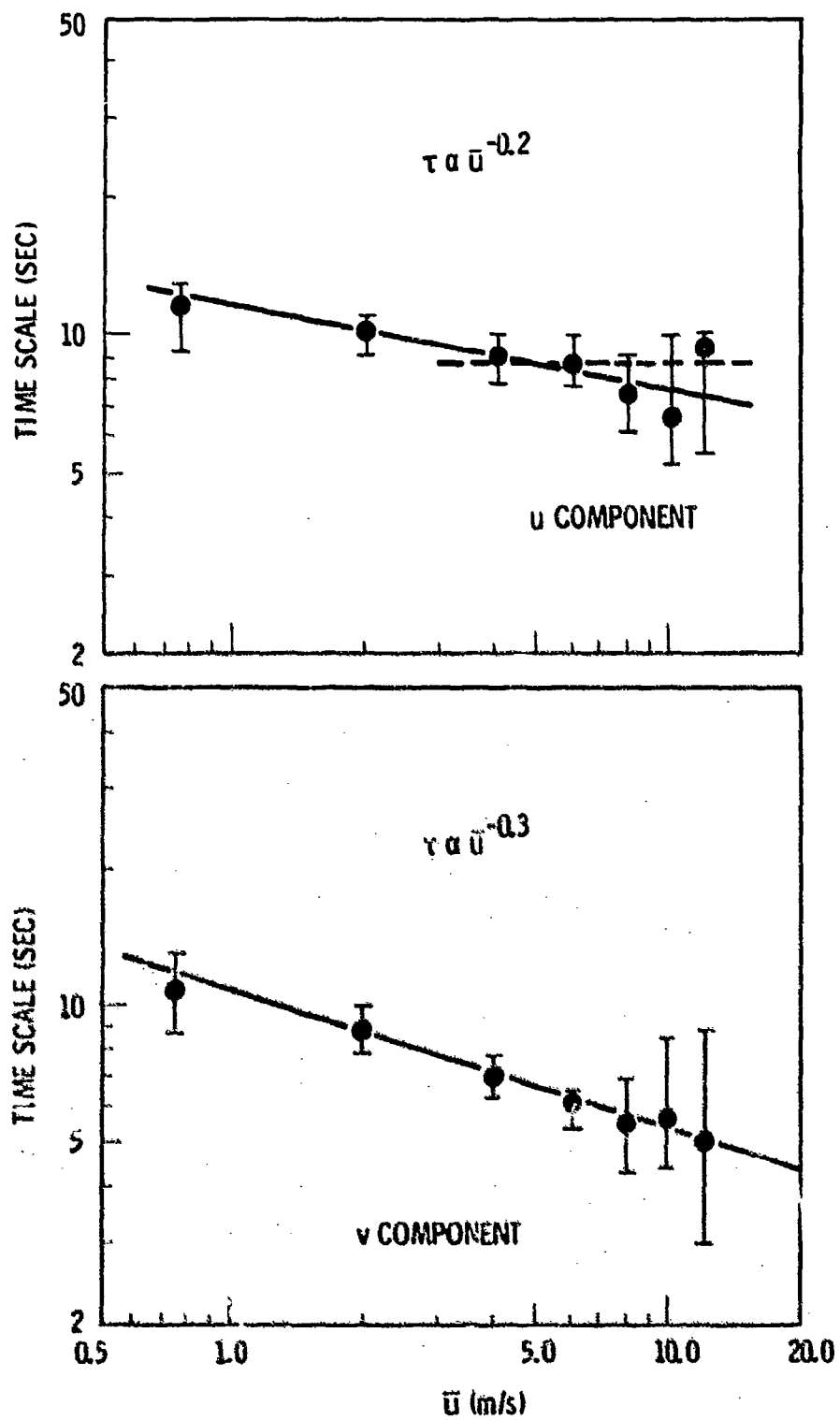

FIGURE 45. Variation of the horizontal component time scales with wind speed at the height of measurement.

The exponent for the longitudinal time scale is approximately -0.2 and that for the lateral is -0.3.

Now, returning to the consideration of horizontal component length scales, Equation (2-10) may be rewritten and extended to

$$L_Y(z) = \bar{u}(z) \tau_Y = B_Y \bar{u}(z)^{1+c_Y} \quad (10-2)$$

This length scale is valid only at the level having the wind speed used in the computation.

#### Vertical Component Length Scales

The development of a vertical length scale model is slightly more complicated since the time scale varies both with wind speed and height. To examine the variation of vertical time scale with height, the time scales in each wind speed category in Table 19 were plotted separately as a function of the logarithm of  $z$ . Figure 46 shows a composite result for wind speed categories between 2 and 10 m/s. Open and closed symbols have been used to distinguish between data from adjacent speed classes, i.e., the first set of open symbols on the left side of the figure correspond to  $u = 8$  m/s, the adjacent set of closed symbols correspond to  $u = 6$  m/s, etc. On the basis of the logarithmic behavior evidenced in this figure, the time scales, normalized by  $\ln z$  were plotted against wind speed. Figure 47 shows the result. The variation is not that of a simple power law. However, for wind speeds of interest for flight simulation, a simple power function may be adequate. Continuing under that assumption, the relationship suggested for wind speeds greater than 3 m/s is

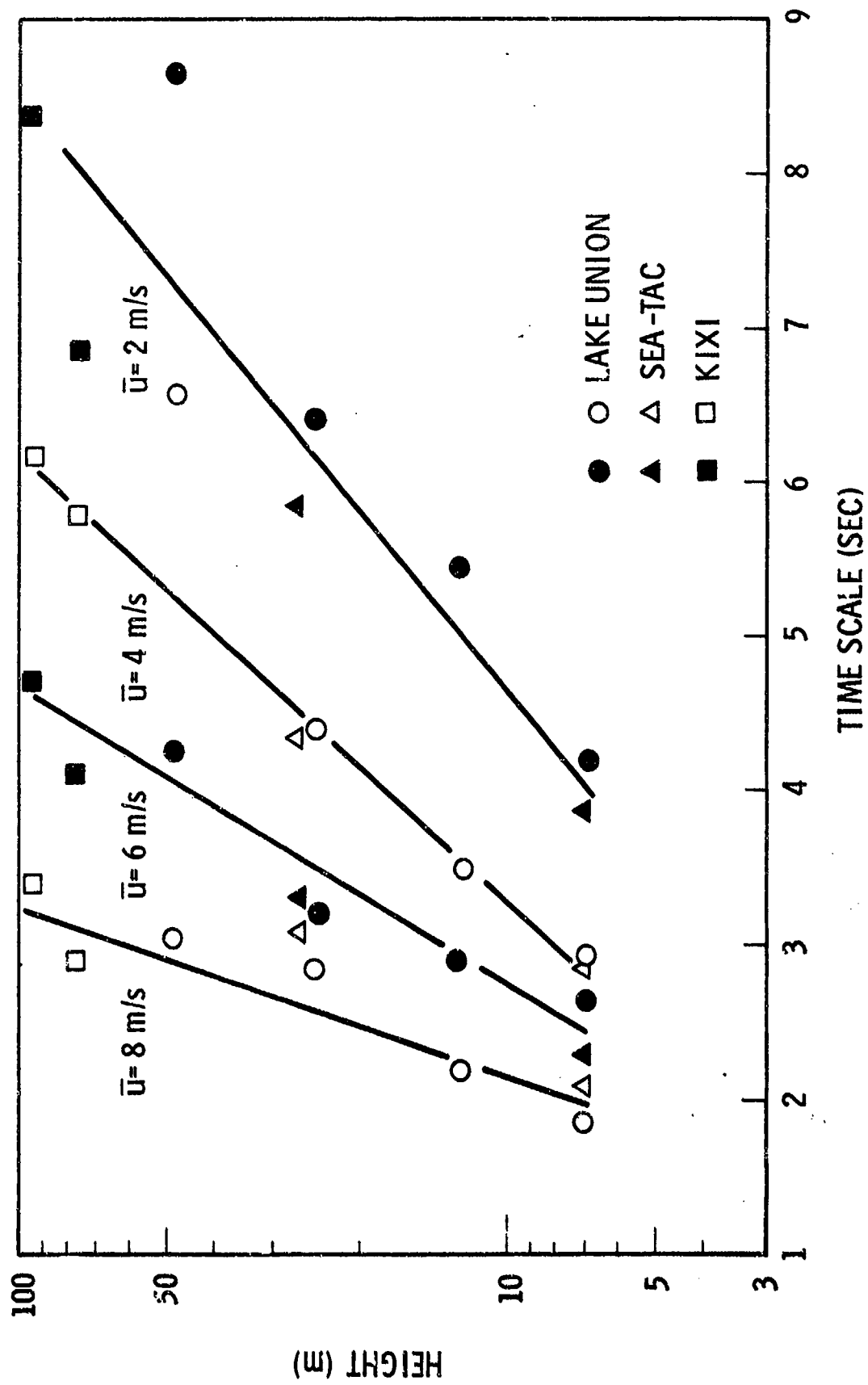

FIGURE 46. Variation of the vertical component time scale with height by wind speed categories.

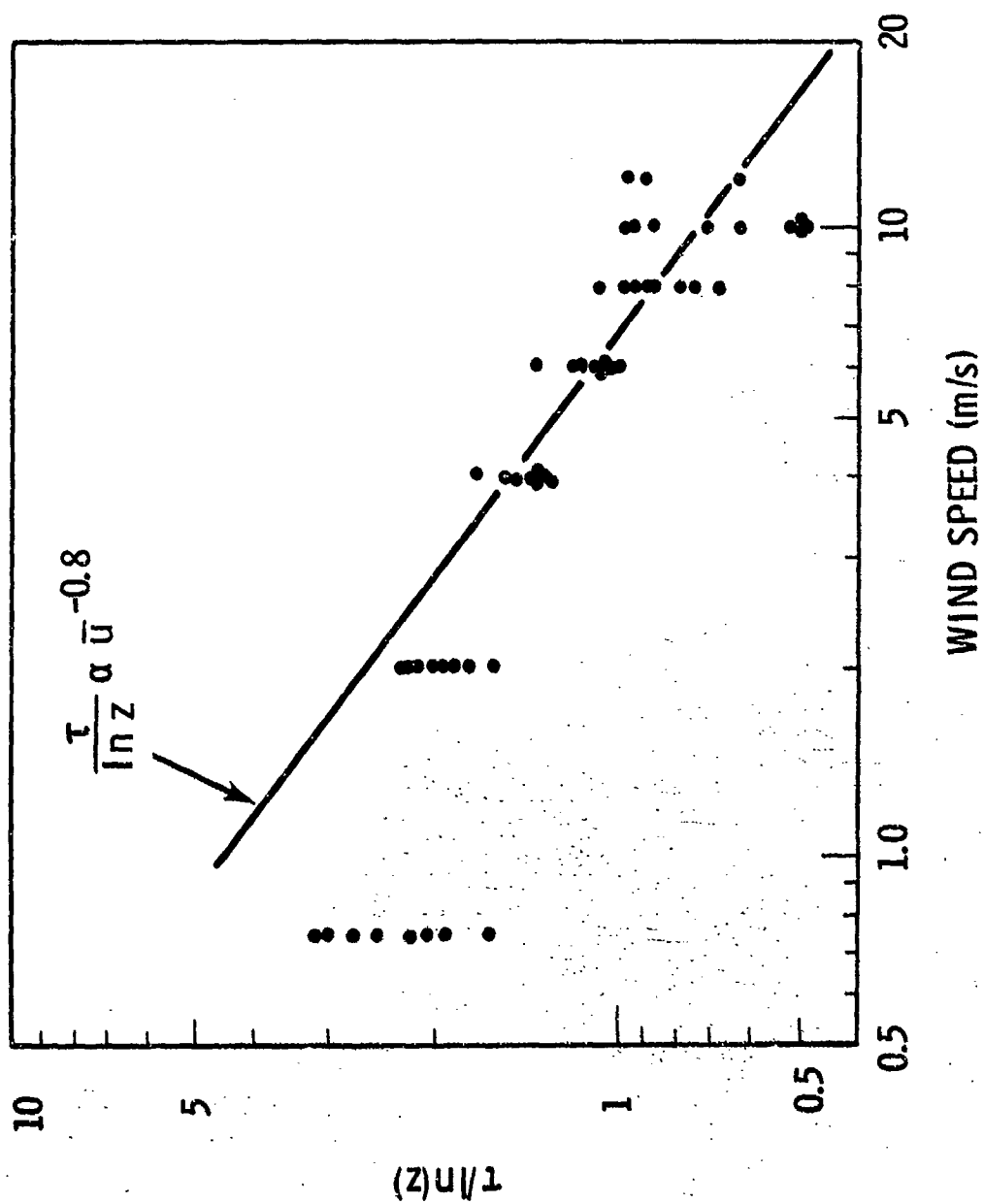

FIGURE 47. Vertical component time scale normalized to  $\ln z$  as a function of wind speed.

$$\tau_w / \ln z = B_w \bar{u}(z)^{c_w} \quad (10-3)$$

Using this relationship, the basic vertical length scale model is

$$L_w(z) = B_w \bar{u}(z)^{1+c_w} \ln z \quad (10-4)$$

Again the model gives a length scale which is applicable only at the height of the wind speed which is used.

If it becomes important to model the vertical length scale at wind speeds less than 3 m/s, the more complicated model,

$$L_w(z) = \frac{2.5 \bar{u}(z) \ln z}{[1 + 0.23 \bar{u}(z)]} \quad (10-5)$$

should be used.

#### Relationship To Spectral Peaks

Since the primary value of the length scales in aeronautical application is the positioning of spectra in wave number space, it is appropriate to recast the length scale models given in Equations (10-2) and (10-4) to provide input needed for the spectral models given in Equations (8-5) and (8-6). Recalling Equation (8-2),

$$(\lambda_m)_\gamma = 2\pi L'_\gamma = 2\pi A_\gamma L_\gamma \quad (8-2)$$

where  $\lambda_m$  is the wave length at the peak of the spectrum,  $L'_\gamma$  is the corresponding scale length, and  $L_\gamma$  is the integral length scale just modeled. This relationship contains a

single unknown,  $A_Y$ , which may be evaluated using the data contained in Tables 9 and 10.

When models are developed for  $L'_Y$ , a product of the constants  $A_Y$  and  $B_Y$  appears. This product is denoted by  $D_Y$ . The coefficients in the integral length scale models can be evaluated using data in Table 9 and the models. These constants have been evaluated with both the intensive and climatological measurement program data. The results are contained in Table 20. For each component the parameter values determined from the intensive measurement data are on the upper line, while those evaluated from the climatological data are on the lower line. The values of  $c_Y$  were obtained from the climatological data presented in Figures 45 and 47. It will be noted that the values of  $D_Y$  are generally the same. This reflects the use of the single set of composite spectra from the intensive measurements at Lake Union in the evaluation of  $A_Y$ . This was done because considerably more confidence can be placed in them than could be placed in composite spectra for the corresponding climatological data.

Using these coefficients, the length scale models for use with the spectral models become

$$L'_u(z) = 18 \bar{u}(z)^{0.8} \quad , \quad (10-6)$$

$$L'_v(z) = 12 \bar{u}(z)^{0.7} \quad , \quad (10-7)$$

and

$$L'_w(z) = 3.2 \bar{u}(z)^{0.2} \ln z \quad . \quad (10-8)$$

These forms are convenient for use in flight simulations where a wind speed profile is readily available.

TABLE 20. LENGTH SCALE MODEL PARAMETER VALUES

<u>Component</u>	<u>A<sub>Y</sub></u>	<u>B<sub>Y</sub></u>	<u>C<sub>Y</sub></u>	<u>D<sub>Y</sub></u>
u	0.71	25	----	18
	1.5	12	-0.2	18
v	0.54	20	----	11
	1.3	10	-0.3	13
w	0.57	5.6	----	3.2
	0.85	3.7	-0.8	3.1

Upper Level Length Scales Based on Surface Winds

In some cases it may be desirable to estimate length scales at a level different from the height of a wind speed measurement. In particular, these cases might arise when evaluating the suitability of V/STOL port sites. To adapt the length scale models given in Equations (10-5) through (10-7) for this use, it is necessary to introduce a wind profile relationship. Equation (9-6) related the wind speed at an arbitrary height,  $z$ , to a reference height,  $z_r$ , for which wind speed data is available through the logarithmic profile. This relationship is repeated here.

$$\bar{u}(z) = \bar{u}_r \frac{\ln(z/z_0)}{\ln(z_r/z_0)} \quad (9-6)$$

Remembering that  $z_0$  is a function of wind direction, this relationship may be used to replace the wind speed in Equation (10-6) through (10-8) (a function of height) with a wind speed for a single level. When this is done Equations (10-9 through (10-11) result.

$$L'_u(z) = \frac{18}{[\ln(z_r/z_o)]^{0.8}} [\bar{u}_r \ln(z/z_o)]^{0.8} \quad , \quad (10-9)$$

$$L'_v(z) = \frac{12}{[\ln(z_r/z_o)]^{0.7}} [\bar{u}_r \ln(z/z_o)]^{0.7} \quad , \quad (10-10)$$

$$L'_w(z) = \frac{3.2}{[\ln(z_r/z_o)]^{0.2}} [\bar{u}_r \ln(z/z_o)]^{0.2} \ln z \quad . \quad (10-11)$$

For a given wind direction, the leading term in each of these equations is constant. Thus, when the roughness length is estimated and the reference height is known, this term may be reduced to a single value. In addition, if the roughness length is about 1 m or the  $|\ln z| \gg |\ln z_o|$ , the roughness length may be neglected without introducing a significant error. In these forms the length scale models can be readily applied to V/STOL aircraft design and certification by use of an appropriate wind speed taken from the distribution given in Figure 3-1 of Barr et al. (1974).

#### LENGTH SCALE MODELS, FREQUENCY DISTRIBUTIONS

As with the rms gust velocities, the modeling of mean length scales does not provide a complete description. In each wind speed category at each height, if there were more than a single observation, a distribution of observed values existed. These distributions must be modeled to satisfactorily complete the description of length scales.

Figures 41 through 43 provide indications that a log-normal model might prove to be suitable. This is, in fact, the case.

Figure 48 shows the distribution of vertical length scales observed in the climatological measurement program. The distributions for three wind speed categories at 6.9 m and for the 3-5 m/s wind speed category at the 12.6, 24.8 and 48.2 m levels are shown. The slopes of different curves are similar which indicates that the standard deviation of the natural logarithms of the vertical length scale are independent of wind speed and height. The distributions, themselves, are positioned by the mean length scale which is a function of wind speed and therefore of height.

On the basis of the conclusions drawn from Figure 48, it can be hypothesized that the standard deviations for the longitudinal and lateral length scale distributions are also independent of wind speed and height. This hypothesis was verified using the length scale data and found to hold within the limits of the observed conditions. There were insufficient observations during high wind speed conditions to check the hypothesis in wind speeds above 7 m/s. However, horizontal component length scale data presented by Brook (1974) for wind speeds above 7 m/s lend additional support to the hypothesis.

Assuming the validity of the above hypothesis, it is possible to estimate the probability of observing a component length scale,  $L_Y$ , within a finite range  $l_Y - \epsilon$  to  $l_Y + \epsilon$  through the conditional probability statement

$$P(l_Y - \epsilon \leq L_Y \leq l_Y + \epsilon | \bar{u}) = \frac{1}{\sqrt{2\pi} s'_Y} \int_{\ln(l_Y - \epsilon)}^{\ln(l_Y + \epsilon)} \exp\left\{-1/2\left(\frac{\ln L_Y - \ln \bar{L}_Y}{s'_Y}\right)^2\right\} d(\ln L_Y),$$

(10-12)

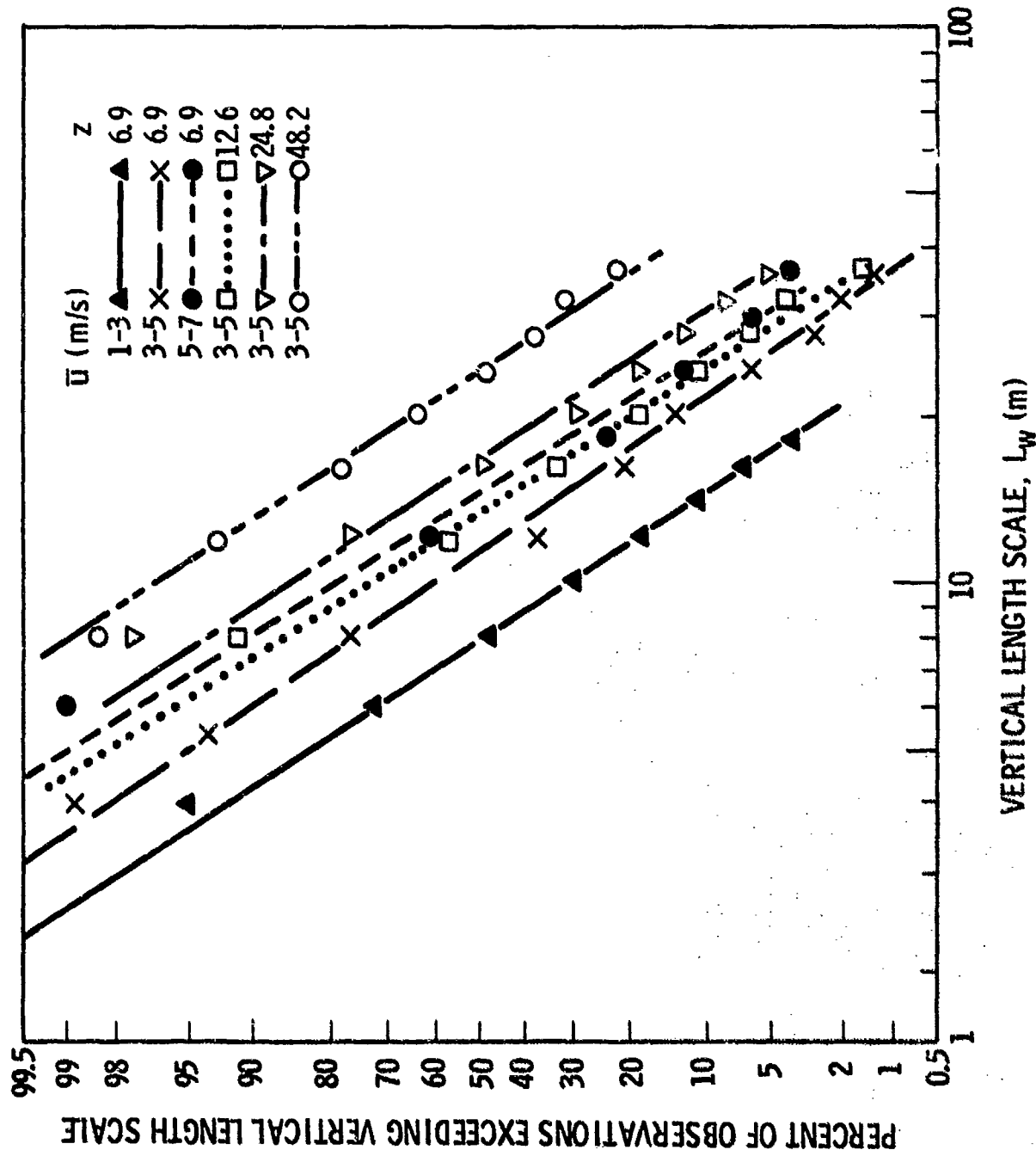

FIGURE 48. Frequency distributions of vertical length scales at Lake Union.

where  $\bar{u}$  is the wind speed,  $s'_Y$  is the standard deviation of the values of  $\ln(L_Y)$ , and  $\bar{L}_Y$  is the geometric mean length scale for the given wind speed. This, of course, is the model used for the distribution of rms gust velocities restated for length scales.

The values of  $s'_Y$  obtained from the survey are given in Table 21. It should be noted that there is little variation in the values between components or sites. A single value,  $s'_Y = 0.5$ , could be used with little loss of accuracy of the model. The length scale models given in Equations (10-2) and (10-5) provide usable approximations of the geometric mean length scales.

TABLE 21. STANDARD DEVIATIONS OF  $\ln(L_Y)$

Site	Component		
	$L_u$	$L_v$	$L_w$
Lake Union	0.48	0.53	0.50
KIXI	0.49	0.49	0.48
SEA-TAC	0.51	0.55	0.48

#### LENGTH SCALE MODEL EVALUATION

The proof of models is in evaluation with data. The length scale models just developed are based on data so that they can *a priori* be assumed to represent the survey data reasonably well. However, a question of the generality of the models still exists. In this section the survey length scale data and the models described by Equations (10-6) through (10-8) will be compared with previous data and length scale models.

### Comparison With Data From Other Locations

Teunissen (1970) compiled and presented recent atmospheric data on longitudinal and vertical length scales. The longitudinal length scale data are shown in Figure 49 with his suggested model. To these data have been added the extended test data from the survey sites, the climatological data from Lake Union which were presented in Table 9, the BNW longitudinal length scale model, and the data from Victoria, Australia, recently published by Brook (1974). It is clearly evident that the BNW model is a good fit to these data, particularly above 10 m.

The vertical length scale data are shown in Figure 50. The same additions, except for Brook's data, have been made to the data originally presented by Teunissen. In this case, it is apparent that the survey data from the lowest two levels at Lake Union and the lower level at SEA-TAC indicate longer length scales than would have been expected at those heights.

A possible explanation can be found for this in the response characteristics of vertical component anemometers. According to Horst (1972), vertical Gill anemometers placed at a level of 7 m underestimate the true variance of the vertical wind component by about 35 percent. Since the lost fraction of the variance would be in higher frequencies, the observed autocorrelation function would decrease more slowly than the true autocovariance. This would in turn be translated into an overestimate of the vertical length scale. This effect will be shown clearly in the chapter discussing the response of the cup anemometer to turbulence.

However, the vertical component power spectra do not show evidence of a significant loss of energy in the high frequencies. In addition, when the vertical component spectra for all levels

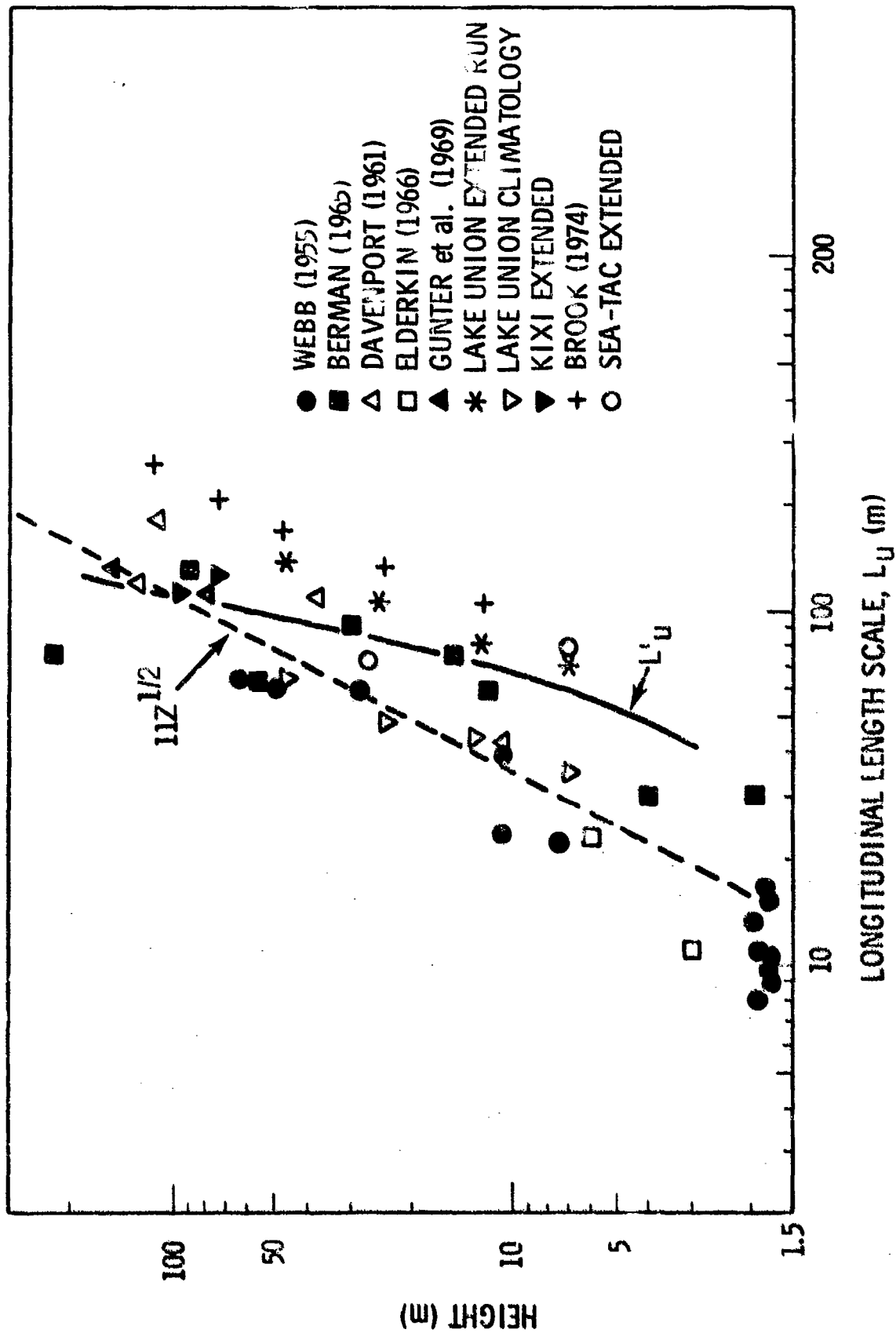

FIGURE 49. Comparison of the suggested longitudinal length scale model and survey data with data from other sites.

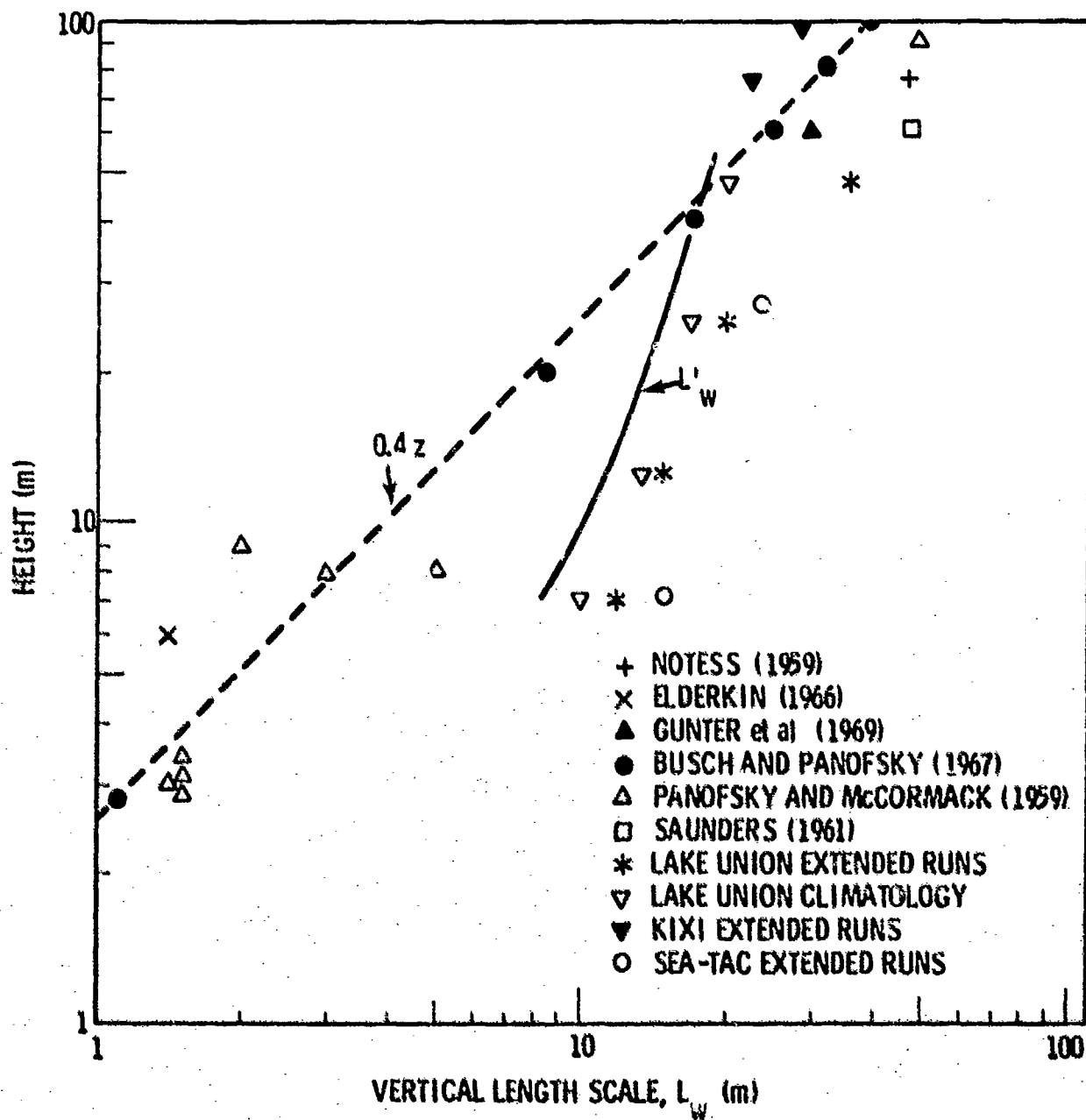

FIGURE 50. Comparison of the suggested vertical length scale model and survey data with data from other sites.

at Lake Union were plotted as a function of both  $nz/\bar{u}$  and  $n$ , the data organized better in the latter case. This is consistent with the model developed earlier in this section.

In view of the discussion above, a vertical length scale model in which the length scale is proportional to the height, such as offered by Teunissen, is considered to be a reasonable alternative to Equation (10-8).

Teunissen did not present a comparable compilation of lateral length scale data.

#### Comparison With Other Models

In addition to comparing the survey results with other data, it is instructive to compare these data and models with length scale models which either are currently used in flight simulation or have been suggested.

Table 22 lists the models which are to be compared. The models labeled BNW are those which were developed in this study. The models of Teunissen are the result of a literature review and are entirely empirical. The models of Barr et al. (1974) were recently developed for the FAA for use in flight simulator certification of landing and approach guidance and control systems. They are based on both theoretical considerations and data, although the greater weight seems to have been placed on theory. Luers (1972) has provided horizontal length scale estimates based upon Teunissen's vertical scale length model, models of the ratios of  $\sigma_u$ ,  $\sigma_v$  and  $\sigma_w$  to  $u_s$ , and the Dryden spectra isotropic relationships. These models were derived without specific reference to data, although they were compared with data. They are included to indicate the possible errors in this approach to modeling. The lateral length scale model of Fichtl

TABLE 22. LENGTH SCALE MODEL SUMMARY

Source	Component		
	$L_u$	$L_v$	$L_w$
BHM Survey	$18 \bar{u}(z)^{0.8}$	$12 \bar{u}(z)^{0.7}$	$3.1 \bar{u}(z)^{0.2} \ln z$
Teunissen	$11 z^{0.5}$	---	$0.4 z$
Barr et al. Boeing (1974)	$\frac{z}{[0.177 + 0.823(z/305)]^{1.2}}$	$\frac{z}{[0.177 + 0.823(z/305)]^{1.2}}$	$z$
Luers (1973)	$2.96 z$	$1.89 z$	---
Fichtl & McVehil (1970)	---	$18 z^{0.42}$	---
Busch & Panofsky (1967)	---	---	$1.5 z^{0.73}$
Dryden MIL-SPEC	$64 z^{0.33}$	$32 z^{0.33}$	$0.5 z$
von Karman MIL-SPEC	$83 z^{0.33}$	$42 z^{0.33}$	$0.5 z$

All heights and speeds are in metric units.

and McVehil (1970) is one of the few models for this component which is based on data. Their data were taken in neutral stability between 18 and 150 m. The Busch and Panofsky (1967) model has resulted from the evaluation of spectral data. And, finally, the Dryden and von Karman MIL-SPEC length scale models are those contained in a recent revision to MIL-F-8785B(ASG) (Chalk et. al., 1973).

In Figure 51 the longitudinal length scale models listed in Table 22 are shown with the survey data. It is interesting to note that the models developed primarily from theory do not adequately represent the data.

The four lateral length scale models are compared with the survey data in Figure 52. Again the data follow the two models based on data better than those based primarily on theory. The scatter of the data, particularly between the extended tests and climatological observations, is the result of the difference in sampling times.

Comparison of the survey data and BNW vertical length scale model with the comparison models in Figure 53 shows that none of the comparison models adequately describe the data. The vertical length scales observed at low levels were significantly larger than would have been predicted. This might have been considered an urban effect had not the SEA-TAC length scales been the largest.

An interesting feature of these last figures is that they show the length scales needed to properly position the respective spectral models are less than the integral scales computed from the intensive measurement data. This indicates that there is energy in turbulence at low frequencies which contributes excessively to the integral scale. This energy remains even

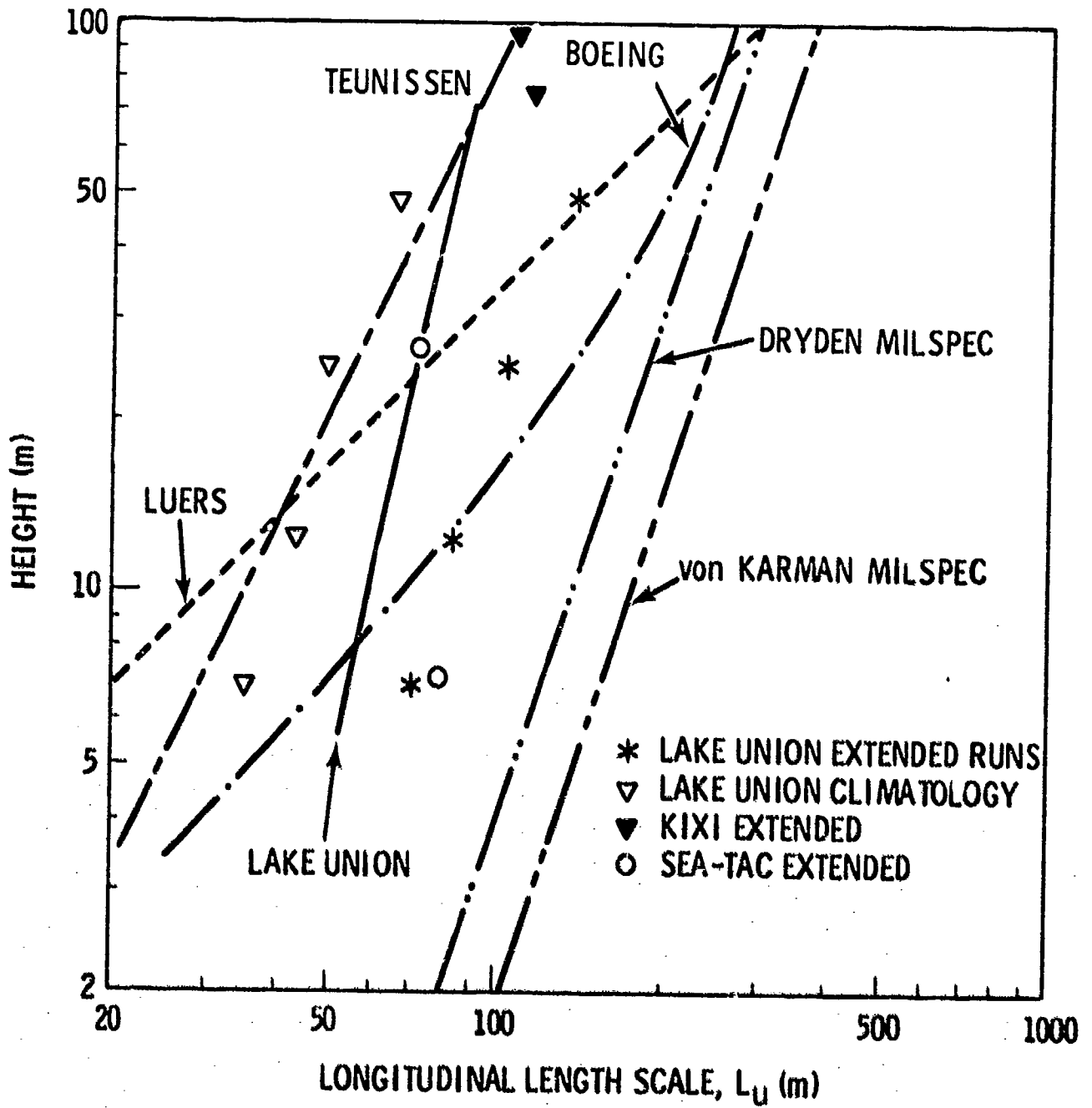

FIGURE 51. Comparison of longitudinal length scale models.

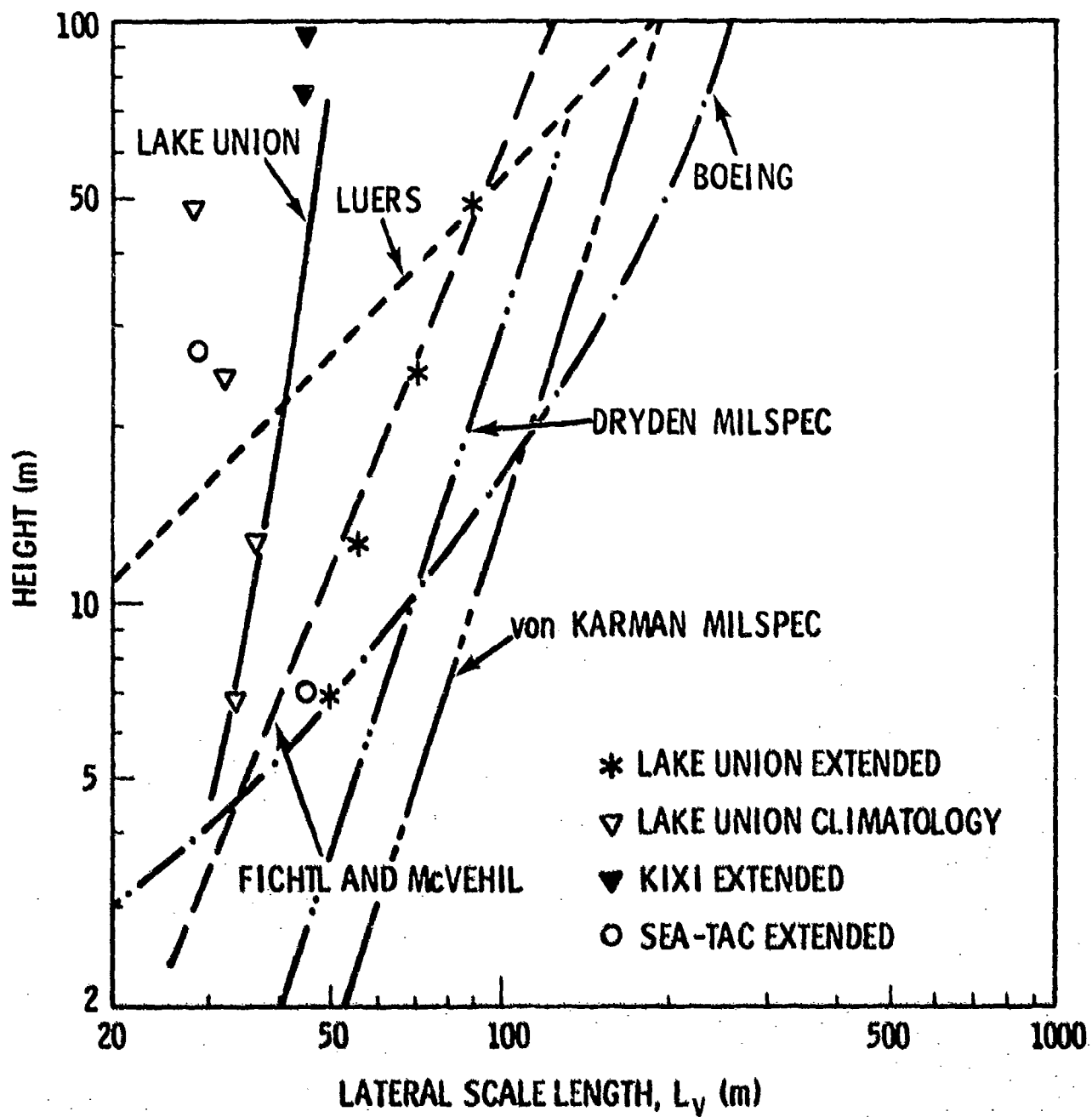

FIGURE 52. Comparison of lateral length scale models.

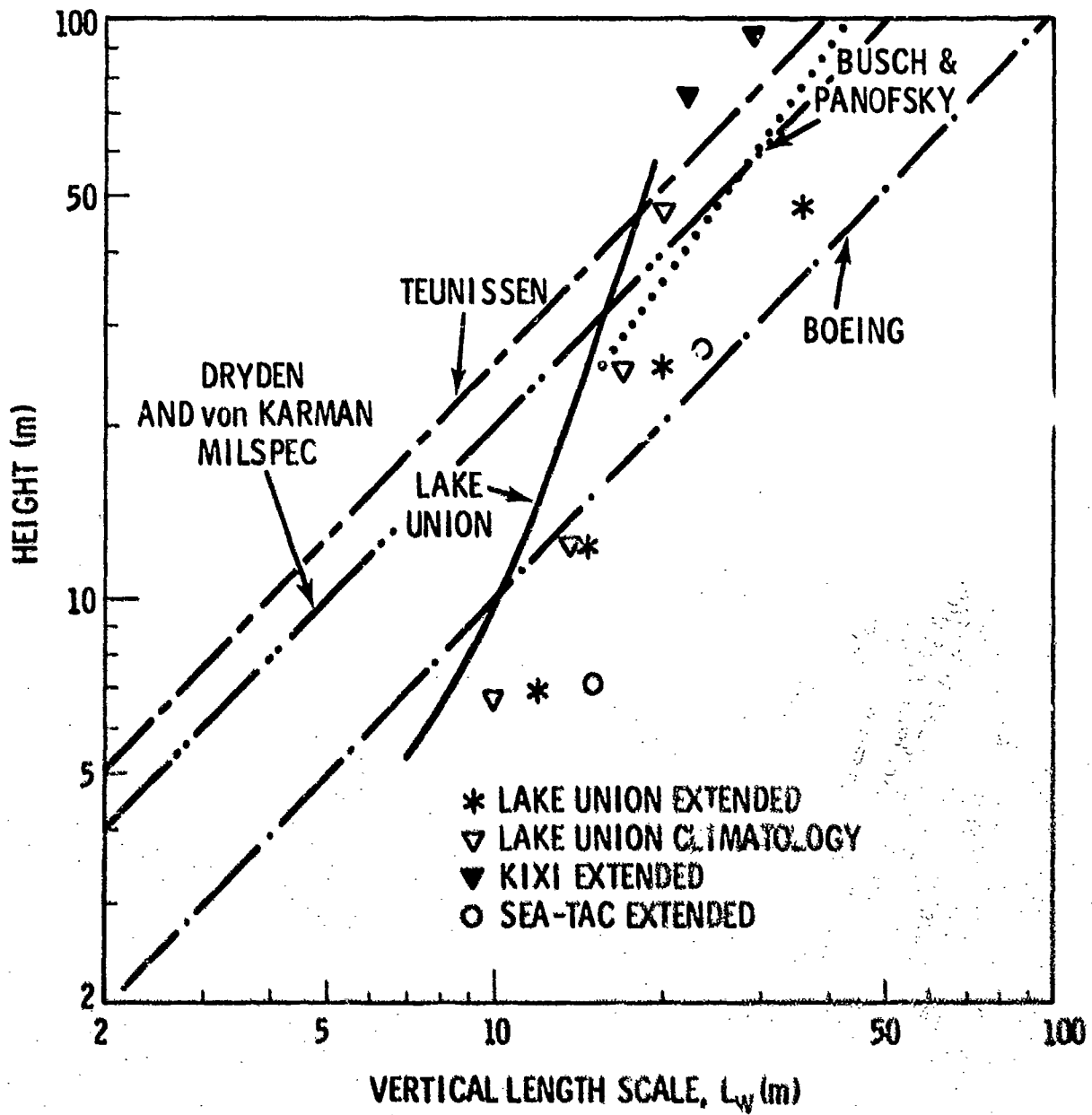

FIGURE 53. Comparison of vertical length scale models.

though the data have been high-pass filtered through the finite record length and detrending. The use of length scales derived from the fitting of models to spectra is more appropriate for application to aircraft flight simulation than is the use of the observed integral scales. If the observed integral scales are to be used, a correction factor should be applied to account for the excess low frequency contribution.

#### LOCAL ISOTROPY RELATIONSHIPS

Before leaving this section one final topic deserves attention. That topic is local isotropy relationships between the turbulence length scales and variances. These relationships are derived for a given set of spectral models by requiring that the turbulence represented reduce to isotropic turbulence at high frequencies, frequencies which are well beyond those of importance to aircraft. As a result of this derivation, the specific forms of the relationship vary from one model to the next. Chalk et al. (1973) give the relationship

$$\frac{L_u}{\sigma_u^2} = \frac{2L_v}{\sigma_v^2} = \frac{2L_w}{\sigma_w^2} \quad (10-13)$$

for the Dryden models, and

$$L_u = 2L_v = 2L_w \left( \frac{\sigma_u}{\sigma_w} \right)^3 = 2L_w \left( \frac{\sigma_v}{\sigma_w} \right)^3 \quad (10-14)$$

for the von Karman models.

These relationships are used in conjunction with models for the three length scales and a model for the rms gust velocity of one component to estimate the rms gust velocities for the other components.

In view of the failure of the survey turbulence data to demonstrate a classical inertial subrange which should accompany local isotropy conditions, these local isotropy relationships were examined using the data presented in Table 10. The average of values computed for each of the terms in Equation (10-12) are shown in Table 23. Those corresponding to the terms in Equation (10-13) are shown in Table 24.

TABLE 23. EVALUATION OF THE DRYDEN SPECTRA ISOTROPY RELATIONSHIPS

	<u>Height</u>	$L_u/\sigma_u^2$	$2L_v/\sigma_v^2$	$2L_w/\sigma_w^2$
<u>Extended Tests</u>	6.9	39	92	62
	12.6	42	91	45
	24.8	43	104	45
	48.2	51	157	110
<u>Climatological Data</u>	6.9	23	68	52
	12.6	27	65	43
	24.8	27	62	38
	48.2	27	66	95

In both tables the variation of values is large. Had either isotropy relationship described the data, the values in the table corresponding to that relationship would have been approximately the same at each level. Significant errors would have been introduced into rms gust velocities computed using either relationship. It is better to model all rms

gust velocities and length scales directly than to trust extrapolation from theoretical relationships at frequencies beyond the threshold of aircraft dynamic response.

TABLE 24. EVALUATION OF THE VON KARMAN SPECTRA ISOTROPY RELATIONSHIPS

	<u>Height</u>	<u>L<sub>u</sub></u>	<u>2L<sub>v</sub></u>	<u>2L<sub>w</sub>(σ<sub>u</sub>/σ<sub>w</sub>)<sup>3</sup></u>	<u>2L<sub>w</sub>(σ<sub>v</sub>/σ<sub>w</sub>)<sup>3</sup></u>
<u>Extended Tests</u>	6.9	70	98	242	110
	12.6	82	112	152	76
	24.8	104	140	180	76
	48.2	138	176	598	162
<u>Climatological Data</u>	6.9	35	68	156	84
	12.6	43	72	104	60
	24.8	49	64	100	44
	48.2	65	56	556	114

## CHAPTER 11

### SPATIAL ASPECTS OF TURBULENCE

The last chapter completed the discussion of the conventional, 1-point turbulence data collected during the survey. In this chapter, spatial aspects of turbulence will be considered.

During the survey, turbulence measurements were made at 13 points in a three-dimensional array of instruments at Lake Union. This array was specifically designed to provide data which could be used in description of the spatial aspects of turbulence in an urban area. The data from 6 periods of selected intensive measurements have been subjected to initial analysis. However, a suitable framework has not been developed within which the results can be summarized. In fact, it is evident that there isn't a consensus about the proper way to analyze the data.

#### SPACE-TIME CORRELATIONS

The analysis which has been completed has included computation of the spatial correlations for each of the separations between instruments along the longitudinal, lateral and vertical lines of instruments. For this analysis, the wind data were rotated so that the u-component of the wind represents the wind along the longitudinal tower axis. In this reference frame the mean crosswind component is not zero unless the mean wind vector parallels the line of towers. This is similar to analyzing the data in an aircraft axis reference system.

Figures 54 and 55 show space-time correlograms for longitudinal separations in two of the tests. The case depicted in Figure 54 is that of wind parallel to the longitudinal axis of the tower array. The mean wind speed was 6.2 m/s at the 24.8 m level, and of course there was no crosswind. In the other test the mean wind speed at 24.8 m was 11.5 m/s at an angle of  $24^\circ$  from the tower array longitudinal axis, giving a longitudinal component of 10.5 m/s and a crosswind component of 4.7 m/s.

These correlograms have several features in common. First, the Eulerian space and time correlations represented by the isopleths crossing the coordinate axes (time lag = 0 and longitudinal separations = 0, respectively) decrease most rapidly for the vertical wind component. Second, the maximum correlation tends to be aligned along the line labeled  $x = \bar{u}t$  in the first case and  $x = \bar{u} \cos \theta$  in the second. If Taylor's hypothesis that the space and time correlations are the same when  $x = \bar{u}t$  were to be fully verified, the maximum correlations would fall exactly along this line. As it is, the line of maximum correlations falls just above the  $x = \bar{u}t$  line. This indicates that the turbulence is advected slightly faster than the mean wind speed would indicate. Elderkin et al. (1972) and Elderkin and Powell (1971) obtained similar results in measurements of turbulence over the desert at Hanford.

To fully describe the behavior of space-time correlations, an additional 3 correlograms would be needed for each case (each correlogram treating the three wind components). One correlogram would be required for lateral separations and two for vertical separations. Two correlograms are required for the vertical because the spatial correlations decay differently for increasing separations depending on whether the reference level is chosen as the upper level and the second level

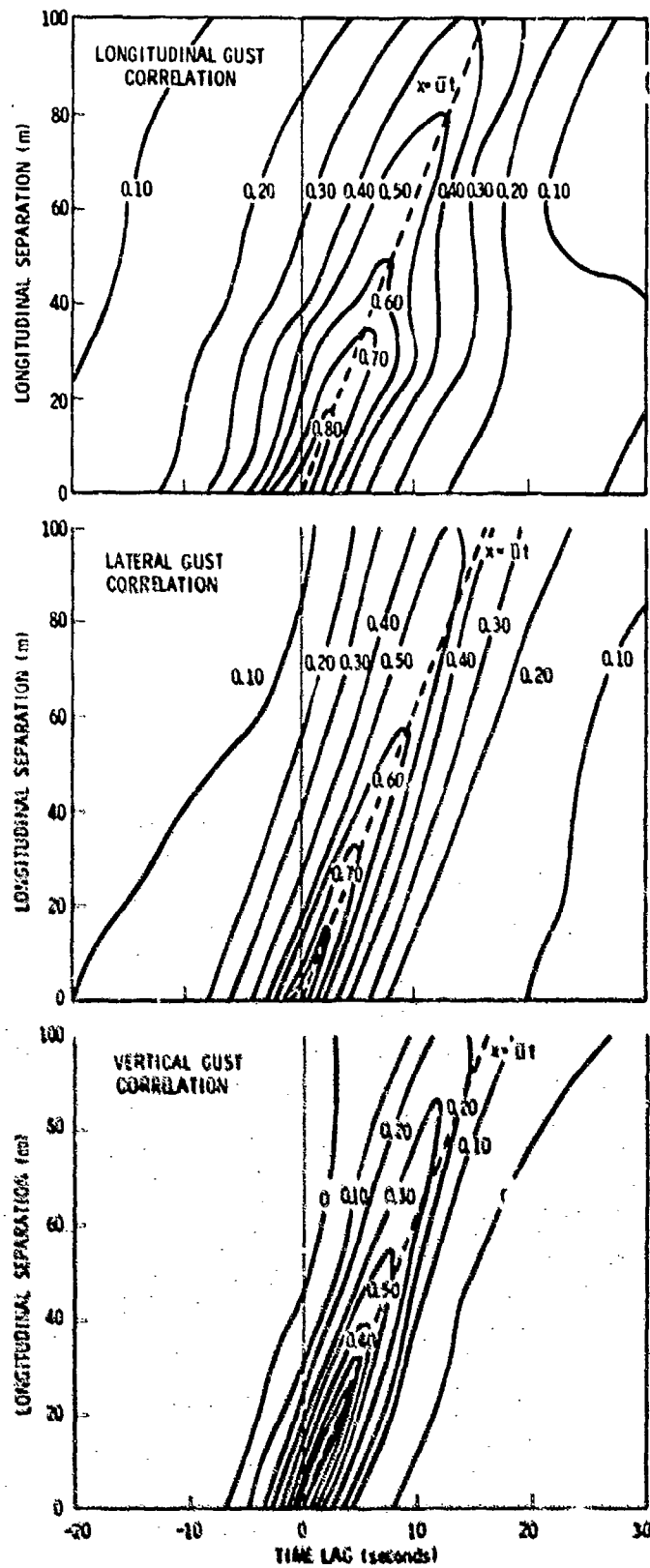

FIGURE 54. Space-time correlations with a 6.2 m/s wind parallel to the longitudinal axis of the Lake Union tower array.

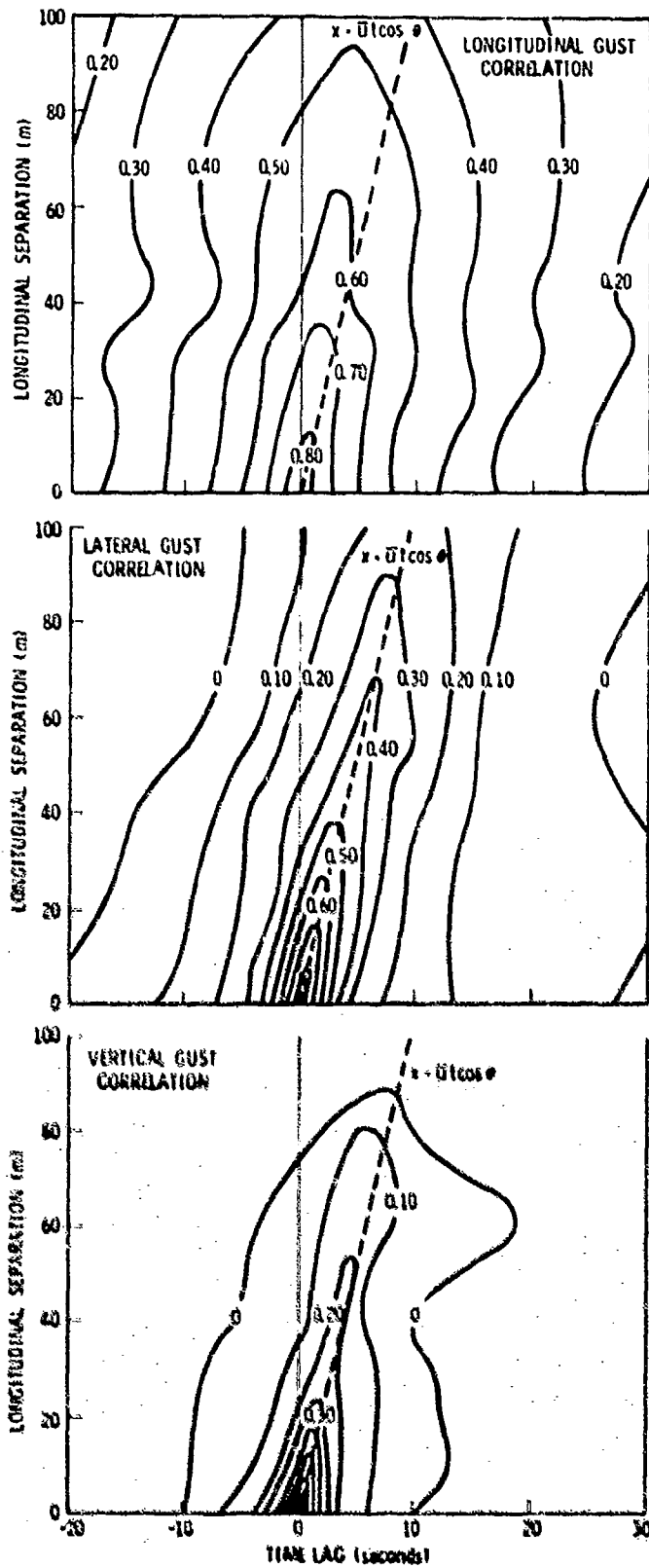

FIGURE 55. Space-time correlations with a 11.5 m/s wind at an angle of  $24^\circ$  to the longitudinal axis of the Lake Union tower array.

descends or the lower level is the reference level and the second level ascends. In the first instance the correlation will decrease slowly at first, then more rapidly as the second level nears the surface, while in the second instance the correlation will decay rapidly at first then more slowly at large separations.

The longitudinal correlograms for longitudinal separations were shown because they can be readily interpreted in terms of horizontal aircraft flight. To illustrate, a typical correlogram is shown in Figure 56. This correlogram includes both positive and negative longitudinal separations to facilitate the description, although all the information is contained in the top half.

If an aircraft were capable of flying with infinite speed into the wind, the correlation of gusts experienced by the aircraft would decay as the spatial correlations. This is represented by the isopleths of equal correlation crossing the positive longitudinal separation axis. As the aircraft slows down, the correlation experienced is represented by the intersection of the isopleths with the line

$$\phi = \theta - \tan^{-1}(v_a) \quad (11-1)$$

where  $v_a$  is the component of the aircraft ground speed in the direction opposite the wind and  $\phi$  is the angle from the positive time lag axis. When the aircraft ground speed reaches 0, i.e., the aircraft is in a hover, the correlation decays as the time series autocorrelation. Since the autocorrelation is an even function, the autocorrelation decays identically for positive and negative time lags.

If the aircraft starts to fly in the same direction as the wind ( $v_a$  negative), the correlations are still represented

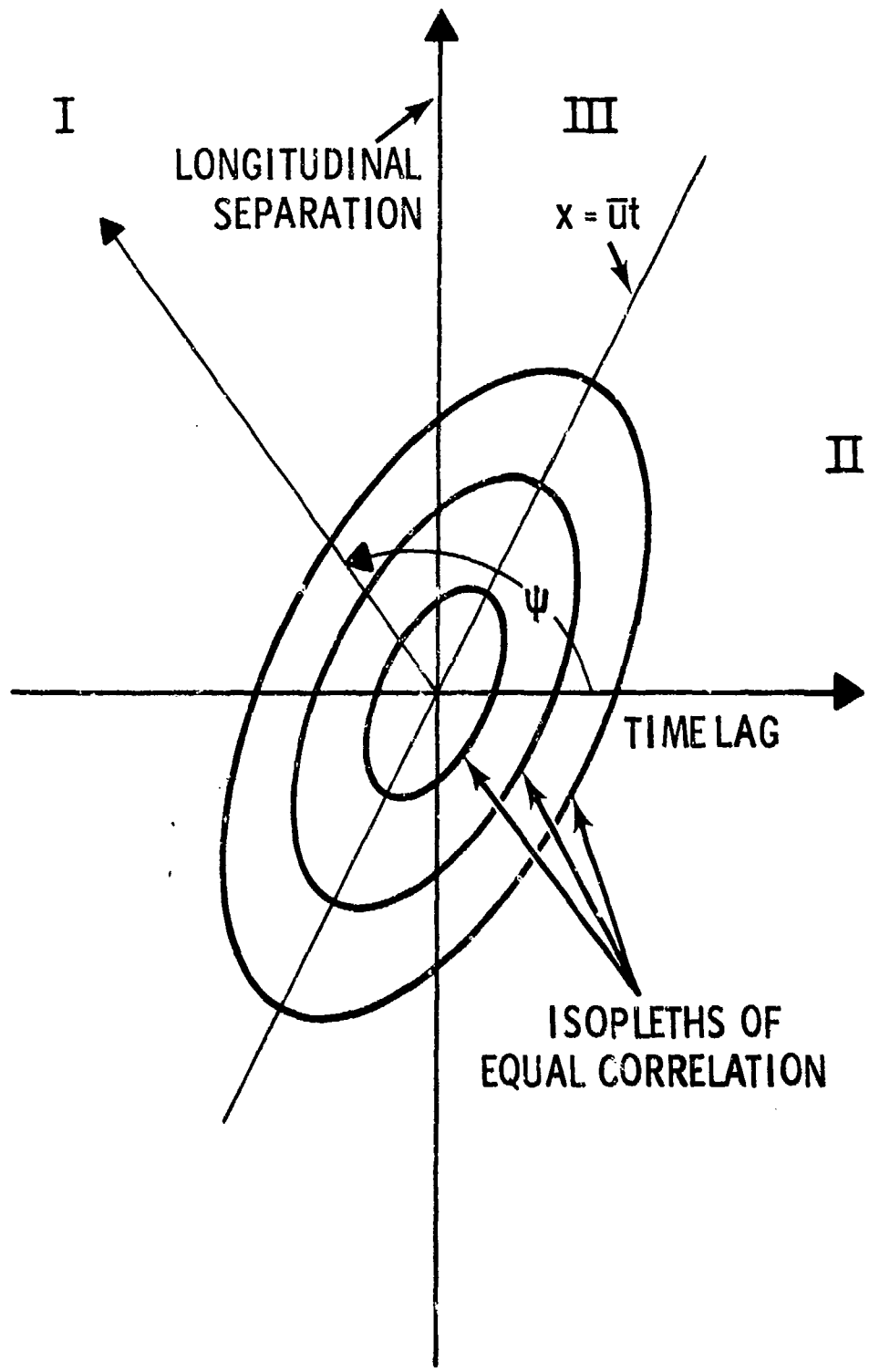

FIGURE 56. Hypothetical space-time correlation for flight in a direction parallel to the mean wind vector.

by the intersection of the isopleths and the line given by Equation (11-1). The correlations persist longest when  $v_a = -\bar{u}$ . This condition gives the maximum integral time and length scales. As the speed increases, the time scale gradually reduces to zero at  $v_a = -\infty$  and again the aircraft experiences only a spatial correlation. The spatial correlation is an even function, assuming horizontal homogeneity. Thus, the information contained in the third quadrant is mirrored in the first.

To summarize the discussion, Table 25 has been prepared.

TABLE 25. SPACE-TIME CORRELOGRAM INTERPRETATION

Condition	Interpretation
Time Lag = 0	$v_a = \pm \infty$
Longitudinal Separation = 0	$v_a = 0$
Region I	$v_a = +$ (into wind)
Region II	$0 < -v_a < -\bar{u}$ (with wind but $ v_a  < \bar{u}$ )
Region III	$-v_a > \bar{u}$ (with wind but $ v_a  > \bar{u}$ )

#### WIND SHEAR

In a second set of spatial analyses, all components of the wind shear in each of six cases were examined. Again no conclusive results are available, but the summarization of the data themselves may be of interest.

As a starting point wind shear may be expressed in finite differences as

$$S_{ij} = \frac{\Delta u_i}{\Delta x_j} \quad (11-2)$$

where  $S_{ij}$  is the shear,  $u_i$  is component of the wind in direction  $i$ , and  $x_j$  is the distance in direction  $j$ . The double subscript on the  $S$  indicates that it is a second-order tensor, i.e., its number of components depends on the maximum values of  $i$  and  $j$ . In this case  $i$  and  $j$  both have maximum values of 3, which gives 9 components of shear.

Without losing any generality, the shear tensor can be divided into mean and fluctuating parts by introducing Equation (2-7) into Equation (11-2). Thus,

$$S_{ij} = \frac{\Delta \bar{u}_i}{\Delta x_j} + \frac{\Delta u_i'(t)}{\Delta x_j} \quad (11-3)$$

By averaging this equation, the mean shear of any component can be shown to be just the shear in the mean of the component. The mean value of the fluctuating part of the shear is zero. Specification of wind shear in cases of atmospheric stability which result in a decoupling of lower and upper level winds can not be treated by boundary layer measurements alone. If, however, it is assumed that the mean shear for a component can be specified through measurement or a profile model, the problem of specifying the shear experienced in a particular case is reduced to specification of the fluctuating or turbulent part of the shear.

One approach to this problem is to treat the turbulent shear as a random variable and attempt to define its distribution. If this can be done, then the probability of significant

shears occurring in a given mean shear condition can be estimated.

It has been established that the mean turbulent shear for any component is zero. It remains to determine the higher moments of the distribution. In this discussion only the second moment will be treated, but the third and higher moments could be treated in the same manner. If the Einstein summation convention is disregarded, the variance of the turbulent shear can be written

$$\sigma_s^2 = \frac{\overline{\Delta u_i}}{\Delta x_j} \frac{\overline{\Delta u_i}}{\Delta x_j} \quad , \quad (11-4)$$

where the overbar indicates averaging. Expanding the right hand side of Equation (11-4) and adding the second subscript to  $u_i$  to indicate the position of measurement,

$$\begin{aligned} \frac{\overline{\Delta u_i}}{\Delta x_j} \frac{\overline{\Delta u_i}}{\Delta x_j} &= \frac{(u_{i2} - u_{i1})(u_{i2} - u_{i1})}{\Delta x_j \Delta x_j} \\ &= \frac{u_{i1} u_{i1}}{\Delta x_j \Delta x_j} + \frac{u_{i2} u_{i2}}{\Delta x_j \Delta x_j} - \frac{2 u_{i1} u_{i2}}{\Delta x_j \Delta x_j} \\ &= \frac{u_{i1} u_{i1}}{\Delta x_j \Delta x_j} + \frac{u_{i2} u_{i2}}{\Delta x_j \Delta x_j} - \frac{2 u_{i1} u_{i2}}{\Delta x_j \Delta x_j} \quad . \quad (11-5) \end{aligned}$$

In the last form the variance of the turbulent shear is seen to be the difference between the sum of the 1-point variances of the component at the two positions and twice the covariance

of the component at the two positions. This equation can be rearranged to give

$$\frac{\overline{\Delta u_i \Delta u_i}}{\Delta x_j \Delta x_j} = \left( \frac{\overline{u_{i1} u_{i1}} + \overline{u_{i2} u_{i2}}}{\Delta x_j \Delta x_j} \right) \left( 1 - \frac{2 \overline{u_{i1} u_{i2}}}{\overline{u_{i1} u_{i1}} + \overline{u_{i2} u_{i2}}} \right) .$$

(11-6)

Assuming that the shear of the longitudinal component of the wind in the longitudinal direction is of interest; i.e.,  $\Delta u_i = \Delta u$ ,  $\Delta x_i = \Delta x$ , and that there is horizontal homogeneity, then

$$\frac{\overline{\Delta u \Delta u}}{\Delta x \Delta x} = \frac{2 \overline{u'^2}}{\Delta x^2} \left[ 1 - \frac{\overline{u'_1 u'_2}}{\overline{u'^2}} \right] . \quad (11-7)$$

This says that the variance of the turbulent shear is just the product of 2 terms; twice the square of the rms longitudinal gust velocity divided by the square of the separation, and 1 minus the spatial longitudinal gust velocity correlation. The longitudinal rms gust velocity was modeled in Chapter 8, and the spatial longitudinal gust velocity correlation was described earlier in this chapter. Thus, if a model were developed for the spatial correlation in terms of easily measured meteorological variables and height, it would be relatively easy to estimate the variance of the turbulent part of the shear.

To approach the third and fourth moments of the turbulent shear requires a significant amount of algebra. Rather than go through that here, observed values of the mean and turbulent parts of the shear are presented in Table 26 for vertical separations for the six cases studied. It should be remembered

TABLE 26. OBSERVED VERTICAL WIND SHEAR AND MOMENTS

COMPONENT	$\Delta z$	MEAN SHEAR	$\sigma$	SKEW	KURT	MEAN SHEAR	$\sigma$	SKEW	KURT
TEST 2-4									
$\Delta u$	5.7*	0.15	0.19	0.40	4.04	0.067	0.12	0.13	4.40
$\Delta v$		0.091	0.20	-0.17	4.11	0.028	0.10	-0.02	3.96
$\Delta w$			0.15	-0.17	3.63		0.074	-0.11	3.32
$\Delta u$	17.9*	0.11	0.093	-0.02	4.04	0.057	0.053	-0.01	3.15
$\Delta v$		0.047	0.088	-0.24	3.47	0.030	0.043	-0.01	3.38
$\Delta w$			0.065	-0.04	3.18		0.034	0.00	3.84
$\Delta u$	-23.4*	0.037	0.073	0.36	3.39	0.014	0.043	0.03	3.39
$\Delta v$		0.017	0.068	-0.06	3.18	0.011	0.032	0.21	3.64
$\Delta w$			0.077	0.22	2.88		0.026	-0.29	4.10
$\Delta u$	-35.6*	0.057	0.052	0.20	3.23	0.027	0.030	-0.06	3.35
$\Delta v$		0.020	0.051	-0.09	3.36	0.018	0.023	0.06	3.00
$\Delta w$			0.045	0.24	2.97		0.016	-0.18	3.35
$\Delta u$	$\pm 41.3^{**}$	0.070	0.045	0.15	3.05	0.032	0.025	0.19	3.60
$\Delta v$		0.030	0.044	-0.22	3.45	0.019	0.019	0.03	3.19
$\Delta w$			0.034	0.34	3.09		0.012	-0.04	3.45
6.9 m WIND		189°	4.8 m/s			202°	4.1 m/s		
TEST 8-23A									
$\Delta u$	5.7*	0.16	0.28	0.27	4.18	0.053	0.33	0.25	4.70
$\Delta v$		0.078	0.26	0.22	4.06	0.025	0.34	-0.15	4.24
$\Delta w$			0.20	-0.12	4.28		0.24	-0.14	4.54
$\Delta u$	17.9*	0.13	0.12	0.37	3.90	0.15	0.15	0.12	3.62
$\Delta v$		0.067	0.12	0.17	3.94	0.058	0.15	-0.01	3.83
$\Delta w$			0.094	0.03	3.67		0.11	-0.13	3.56
$\Delta u$	-23.4*	0.061	0.11	0.55	4.83	0.091	0.14	0.38	3.93
$\Delta v$		0.040	0.085	0.05	4.27	0.041	0.12	0.33	3.82
$\Delta w$			0.071	-0.22	3.93		0.098	-0.13	3.28
$\Delta u$	-35.6*	0.079	0.075	0.41	3.86	0.12	0.096	0.26	3.74
$\Delta v$		0.047	0.067	-0.04	3.91	0.052	0.087	0.04	3.40
$\Delta w$			0.046	-0.15	3.63		0.065	-0.09	2.99
$\Delta u$	$\pm 41.3^{**}$	0.091	0.064	0.36	3.86	0.12	0.086	-0.01	3.34
$\Delta v$		0.051	0.055	-0.01	3.92	0.048	0.081	0.05	3.44
$\Delta w$			0.038	-0.08	3.62		0.054	0.01	2.96
6.9 m WIND		185°	6.7 m/s			189°	8.6 m/s		
TEST 11-11									
$\Delta u$	5.7*	0.15	0.18	0.41	3.73	0.10	0.19	0.48	4.79
$\Delta v$		0.005	0.18	-0.09	3.32	0.066	0.17	0.25	4.09
$\Delta w$			0.12	-0.12	3.47		0.13	0.03	3.15
$\Delta u$	17.9*	0.087	0.080	0.23	3.21	0.083	0.090	0.01	3.65
$\Delta v$		-0.016	0.080	0.00	3.31	0.047	0.070	0.08	3.27
$\Delta w$			0.059	-0.11	2.91		0.059	0.10	3.42
$\Delta u$	-23.4*	0.010	0.062	0.09	3.15	0.048	0.072	0.23	3.36
$\Delta v$		0.004	0.061	-0.11	3.34	0.023	0.057	0.26	3.36
$\Delta w$			0.046	-0.07	2.97		0.045	-0.29	3.31
$\Delta u$	-35.6*	0.027	0.043	0.16	3.01	0.058	0.050	0.18	3.43
$\Delta v$		-0.004	0.043	-0.05	3.05	0.028	0.040	0.13	3.10
$\Delta w$			0.030	0.02	3.09		0.030	-0.16	3.49
$\Delta u$	$\pm 41.3^{**}$	0.043	0.037	0.20	2.95	0.063	0.033	0.28	3.35
$\Delta v$		-0.004	0.037	-0.04	3.00	0.033	0.033	0.18	3.32
$\Delta w$			0.025	-0.02	3.02		0.024	-0.10	3.25
6.9 m WIND		210°	4.6 m/s			185°	4.6 m/s		

\* REFERENCE LEVEL 6.9 m

\* REFERENCE LEVEL 48.2 m

\*\* REFERENCE LEVEL 6.9 m OR 48.2 m

that the winds in these tests are measured in a reference system aligned with the tower arrays. In the table the mean shear and the standard deviation of turbulent shear are given in (m/s)/m, and skew and kurt refer to the coefficients of skewness and kurtosis of the turbulent shear distributions, respectively.

In examining the data in the table there are several things to note. The values of the coefficients of skewness and kurtosis should be compared with the Gaussian values of 0 and 3, respectively. The coefficient of skewness is reasonably close to zero on the average although there is a relatively large scatter. The values of the coefficient of kurtosis, on the other hand, are considerably larger than the Gaussian value of 3. There appears to be a tendency for the largest values of this coefficient to be associated with small separations and for the value to tend toward 3 as the separation increases. This is similar to results reported by Fichtl (1972) and Kumar (1974) for Cape Kennedy.

A second set of comparisons of interest is that between the values of the mean shear and the standard deviation of the turbulent shear. Frequently, the standard deviation of the turbulent shear is as large or larger than the mean shear. The mean shear of the vertical component has not been included since it was generally an order of magnitude smaller than that for the other components. But, the standard deviation of the turbulent shear of the vertical component should be noted, for in many cases it is significant. It is thus evident that successive aircraft making take-offs or approaches may experience significantly different wind shears, none of which are well represented by the mean wind shear.

Finally, the behavior of the mean and turbulent components of the shear should be noted. The mean shear decreases with increasing vertical separation when the 6.9 m wind is used as a reference. When the 48.2 m wind is used as a reference, the mean shear increases with increasing separation. This shows the need to treat the spatial correlations differently for climbing and descending flight. It is possible that, with suitable normalization, this dual formulation can be avoided. A limited amount of success has been achieved using the mean height of the layer to normalize the thickness. Another normalizing length which has been tried is the modeled length scale for the mean height of the layer. In contrast to the behavior of the mean shear, the behavior of turbulent shear is considerably simpler. It decreases with increasing separation.

This examination of spatial data collected during the survey (92 + hours) has treated less than 5 percent of the available data. The initial analysis, discussed here, was conducted to evaluate the data collected and explore possible methods of analysis. The figures and tables presented deal only with horizontal or vertical flight. It would be of value to extend the analysis to examine the turbulence along an inclined flight path, in addition to more detailed examination of horizontal and vertical flight paths.

## CHAPTER 12

### THE FAA STANDARD CUP ANEMOMETER AS A TURBULENCE SENSOR

Cup anemometers conforming to National Weather Service Specification No. 450.6150 were installed at each of the sites to provide a direct comparison between current airport wind sensors and more sensitive turbulence instruments. In Chapter 4, the mean wind speeds measured by the two instruments for the intensive measurement periods were compared (Figure 12). In this chapter the comparison between instruments is extended to turbulence parameters. This comparison is made, not because the cup anemometers might be purchased for use as turbulence instrument but because the instruments are currently in the field and might provide data on turbulence parameters usable for climatological purposes or for operational use by tower operators and air traffic controllers.

#### CUP ANEMOMETER FREQUENCY RESPONSE

The response characteristics of cup anemometers have generally been examined using a first-order differential equation model for the cup and a sinusoidal forcing function (see Middleton and Spillhaus, 1953, or Slade, 1968). Solving this model in terms of the ratio of the output amplitude (cup anemometer signal) to input amplitude (true airspeed change) indicates that the ratio should decrease as a function of the inverse wave length,  $(n/\bar{u})$ , to the -1 power for large values of  $n/\bar{u}$ . Since the power spectrum distributes variance which is associated with amplitude squared, the model results leads to the expectation that power spectral estimates should be attenuated proportional to  $(n/\bar{u})^{-2}$  for sufficiently large  $(n/\bar{u})$ .

The composite power spectrum derived from the measurements of wind speed made by the cup anemometer at Lake Union is shown in Figure 57. It is similar to the composite spectrum for the u component at 6.9 m from the low wave-number region through the transition region. In the region of the inertial subrange, where spectra from the Gill anemometers have a  $-2/3$  slope (see Figures 22-29), the cup anemometer spectrum has a  $-5/3$  slope. Since the  $-2/3$  slope is predicted from theory, it can be assumed that the Gill spectra are correct in this region and that the cup spectrum shows the effects of instrument response characteristics, although not that predicted by simple theory.

To examine this behavior more closely, the ratios of banded spectral estimates for the cup and Gill u component anemometers have been plotted as a function of  $n/\bar{u}$ . The result shown in Figure 58 supports the conclusion drawn from Figure 57. In addition, it provides a clear indication of the inverse wave lengths at which attenuation is important.

For inverse gust wave lengths greater than  $0.01 \text{ m}^{-1}$  (wave lengths less than 100 m), there is a noticeable attenuation of the FAA cup anemometer response. For wave lengths less than 10 m ( $n/\bar{u}$  greater than  $0.1 \text{ m}^{-1}$ ), the response of the cup has been reduced by about an order of magnitude. The anemometer effectively smooths out all fluctuations which occur at smaller wave lengths.

The data used in Figure 58 were obtained from the intensive measurement program. It is interesting to note that again the Lake Union and SEA-TAC data are in good agreement and that KIXI data appear to be separated from the data taken near ground level. In preparing the ratios plotted in the figure unnormalized spectral estimates were used. Had the spectral estimates been normalized by the respective variances, the ratios of the

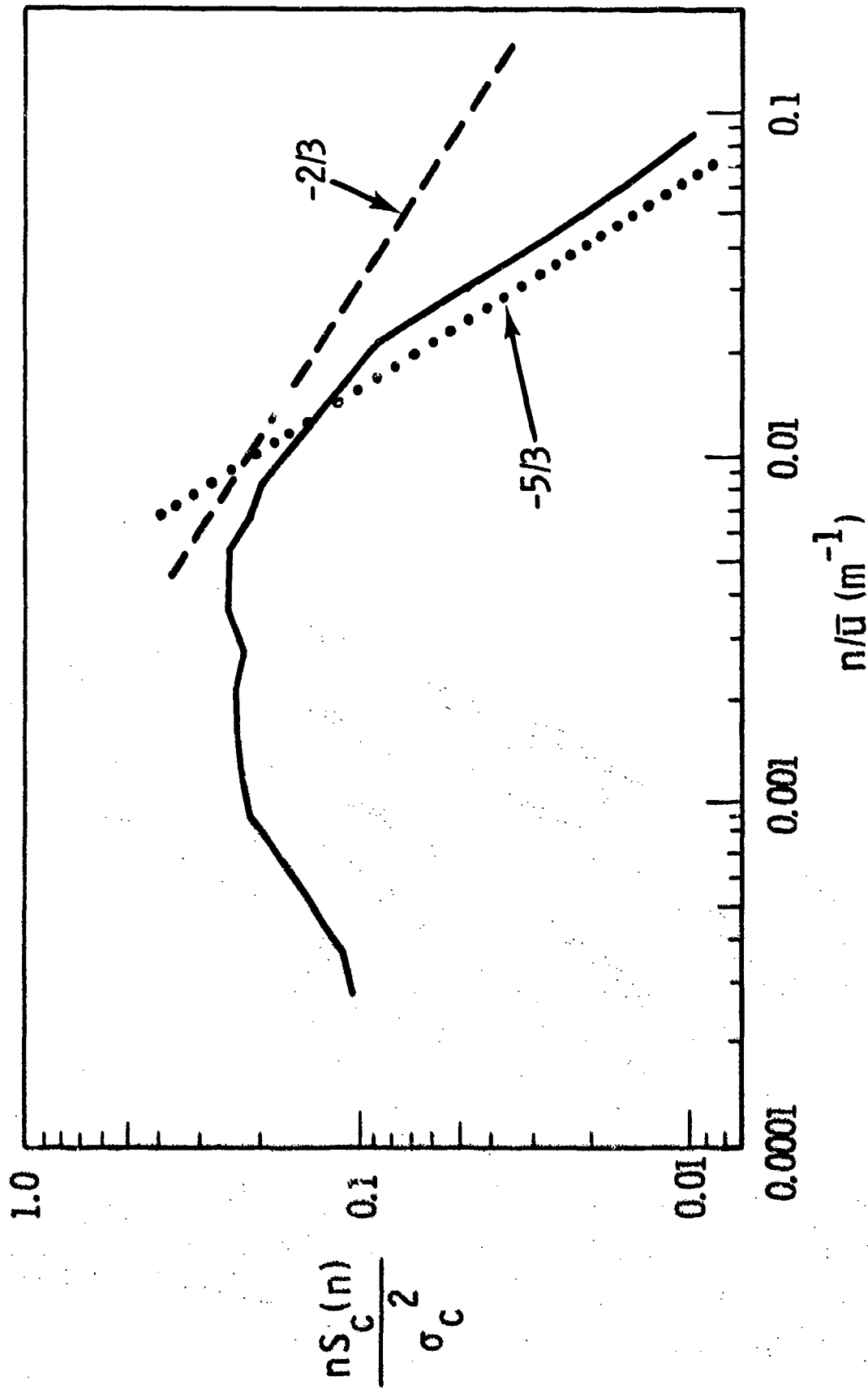

FIGURE 57. Composite longitudinal gust power spectrum for Lake Union from FAA standard cup anemometer measurements.

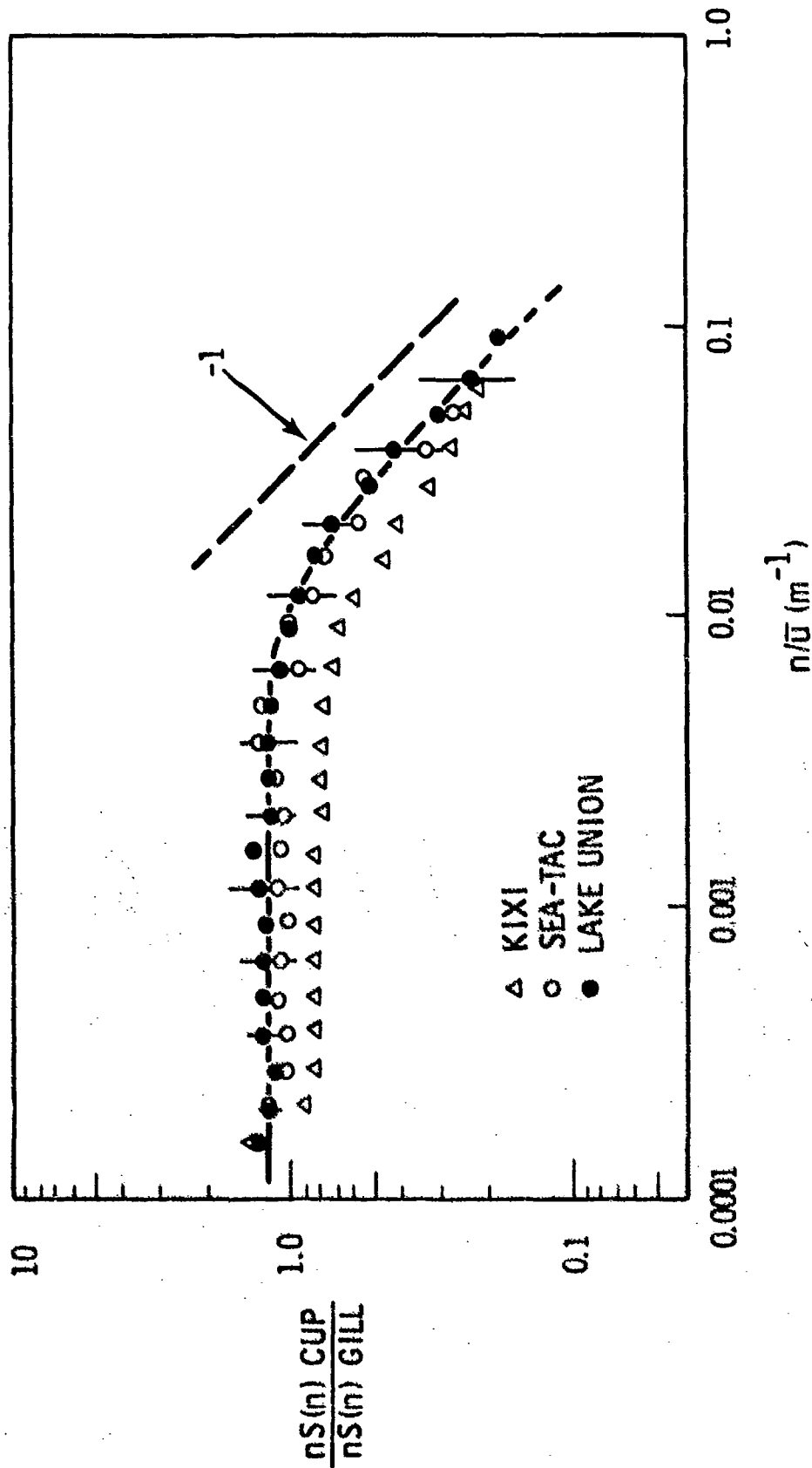

FIGURE 58. Comparison of cup and Gill anemometer longitudinal gust power spectra.

spectral estimates for long-wave lengths would have been closer to 1 at both Lake Union and KIXI.

In attenuation of high-frequency, short-wave length oscillations, the cup anemometer behaves as a low-pass filter. This can be expressed in mathematical terms by

$$nS_c(n) = F_c(n/\bar{u}) nS_g(n) \quad , \quad (12-1)$$

where  $F_c(n/\bar{u})$  is the filtering function which describes the behavior of the cup anemometer,  $S_g(n)$  is the Gill anemometer spectrum, in this case assumed to be the true spectrum, and  $S_c(n)$  is the spectrum obtained from analysis of the cup anemometer data. Horst (1973) presents a comparison between Gill and sonic anemometers which indicates the Gill-longitudinal spectra are representative for  $n/\bar{u}$  less than 0.06. Rearranging Equation (12-1) to conform to the presentation in Figure 58 yields,

$$\frac{nS_c(n)}{nS_g(n)} = F_c(n/\bar{u}) \quad . \quad (12-2)$$

Thus, the shape of the curve in the figure depicts the filtering performed by the cup.

A filter function which fits the data shown in figure 58 is

$$F_c(n/\bar{u}) = \frac{1.2}{[2 + 6300 (n/\bar{u})^2]^{1/2}} \quad . \quad (12-3)$$

It is reasonable to assume that the constant in the numerator should be 1.0 rather than the indicated value of 1.2 unless a mechanism can be hypothesized which would amplify the low

frequency response of the cup anemometer. One possible mechanism could be the noncosine response of the cup anemometer to gusts which include non-zero vertical components. (For a discussion of the noncosine response of cup anemometers see MacCready, 1966.)

#### FREQUENCY RESPONSE CORRECTION

A knowledge of the form of the filtering performed by the cup anemometer makes it possible to at least partially correct spectra obtained from these cup anemometers for the high frequency attenuation. Inverting the relationship in Equation (12-1) the corrected spectrum is given by

$$nS^*(n) = \frac{1}{F_c(n/\bar{u})} nS_c(n) \quad (12-4)$$

where  $nS^*(n)$  is the corrected estimate. Using the filter form given in Equation (12-3), Equation (12-4) may be rewritten

$$nS^*(n) = [0.694 + 4380(n/\bar{u})^2]^{1/2} nS_c(n) \quad (12-5)$$

In wave number space, Equation (12-5) is

$$kS^*(k) = [0.694 + 111 k^2]^{1/2} kS_c(k) \quad (12-5a)$$

If, it is assumed that the constant in the numerator of Equation (12-3) is anomalous, Equations (12-5) and (12-5a) become

$$nS^*(n) = [1 + 6300(n/\bar{u})^2]^{1/2} nS_c(n) \quad (12-6)$$

and

$$kS^*(k) = [1 + 160 k^2]^{1/2} kS_c(k) \quad (12-6a)$$

Some caution should be exercised in the correction of spectra for attenuation due to instrument response. In particular, the correction should not be carried to the extreme that the contribution to a spectrum due to the correction is significantly larger than the uncorrected spectral estimates themselves. In the case of the present anemometer, the correction should not be carried out beyond wave numbers of 0.20 to 0.25  $m^{-1}$ , or  $n/\bar{u}$  of 0.03 to 0.04  $m^{-1}$ . Limiting the correction to this range will give maximum correction factors of about 3. Even these may be larger than should be used. If definition of a spectrum to higher wave numbers is needed, a spectral model should be fit to the data and extrapolated. An example of this would be the assumption that the observed spectrum as corrected had reached the inertial subrange, and that at higher wave numbers the spectrum should decrease proportional to  $k^{-2/3}$ .

#### LONGITUDINAL RMS GUST VELOCITY MEASUREMENTS

It is more probable that the existing airport cup anemometers would be used to obtain climatological estimates of spectral model input parameters than to obtain information on spectra directly. In this section, the rms longitudinal gust velocities determined from cup measurements will be compared with those computed from the Gill anemometer data. It should be noted that throughout this chapter the Gill and cup anemometer data are discussed as though they were identical measurements when, in fact, they are not. The longitudinal gusts, their rms values, spectra and length scales from the Gill anemometers represent variations in the direction of the mean

wind, i.e., they are for the u component where  $\bar{v} = 0$ . The cup anemometer data represent variations of  $(u'^2 + v'^2)^{1/2}$ , i.e., the variations of the instantaneous speed, and as such descriptors derived from them can be expected to differ somewhat from those derived from Gill data.

Figure 59 shows a comparison of the rms longitudinal gust velocities computed with data obtained from the two instruments in the intensive measurement program. The circular points represent the data collected at Lake Union and SEA-TAC, while the triangular points represent KIXI data. The rms gust velocities for the lower level instruments agree quite well, although there is a slight tendency for the cup anemometer to overestimate the lower values and underestimate high values. The overestimated values are to a large extent associated with relatively low mean wind speed. In these cases the higher threshold of the cup anemometer tends to reduce the speeds during lulls to zero and increase the duration of calms. This has the net effect of moving some values toward an extreme of the distribution, thus increasing the rms gust velocity. This would also cause the additional turbulence energy to be found in the lower frequency or wave number position of the spectrum.

#### LONGITUDINAL LENGTH SCALE ESTIMATES

Longitudinal turbulence length scales computed from data obtained from the two anemometers at each site during the intensive measurements are compared in Figure 60. It is immediately evident that the length scales computed from the cup anemometer data are consistently larger than those derived from the Gill data. This can be attributed in part to the cup anemometer's attenuation of the higher frequency turbulence input. To explain, the length scale is computed from the integral of the autocorrelation of the wind speed time series. (See Equations

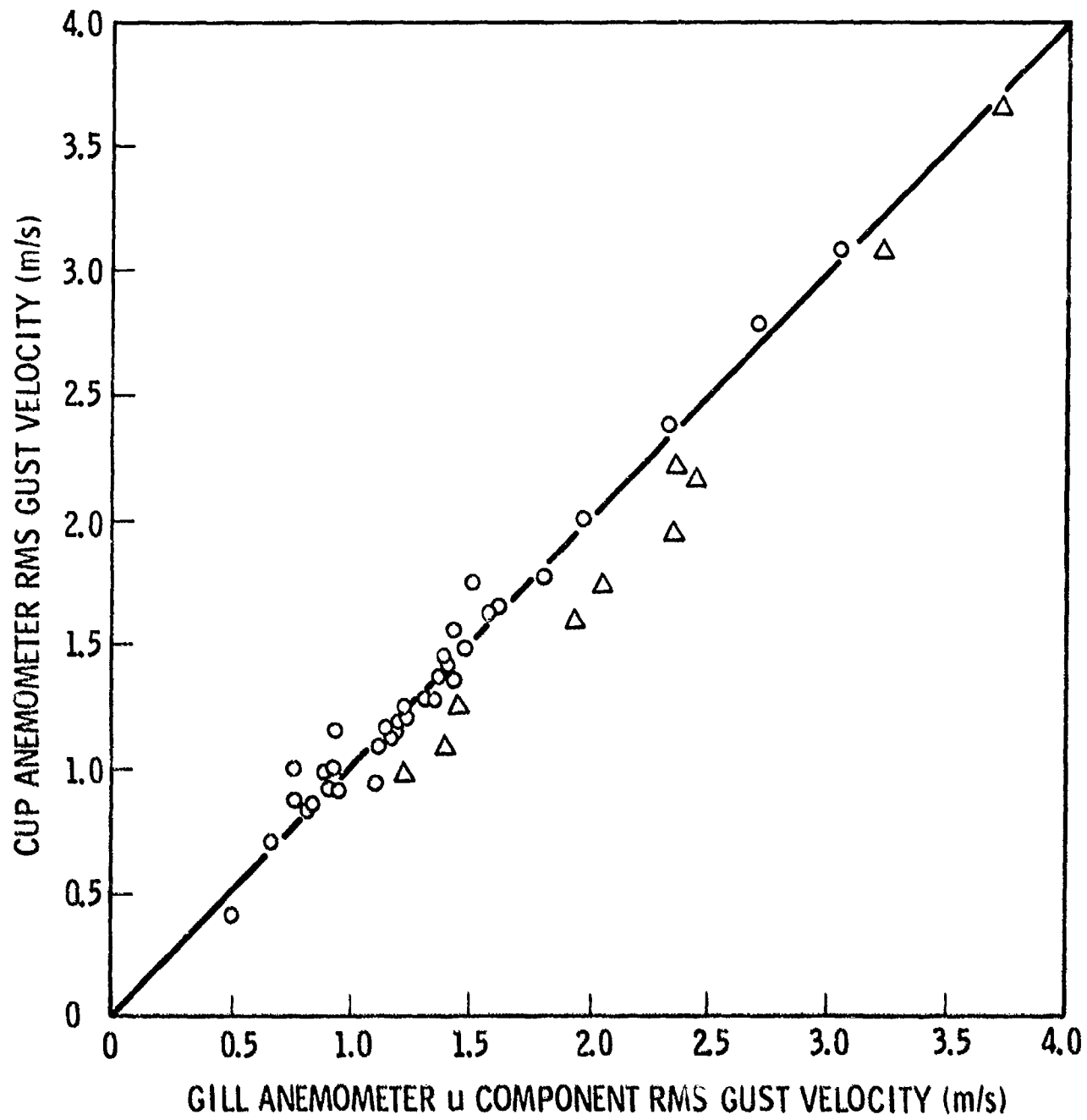

FIGURE 59. Comparison of longitudinal rms gust velocities determined from cup and Gill anemometer measurements.

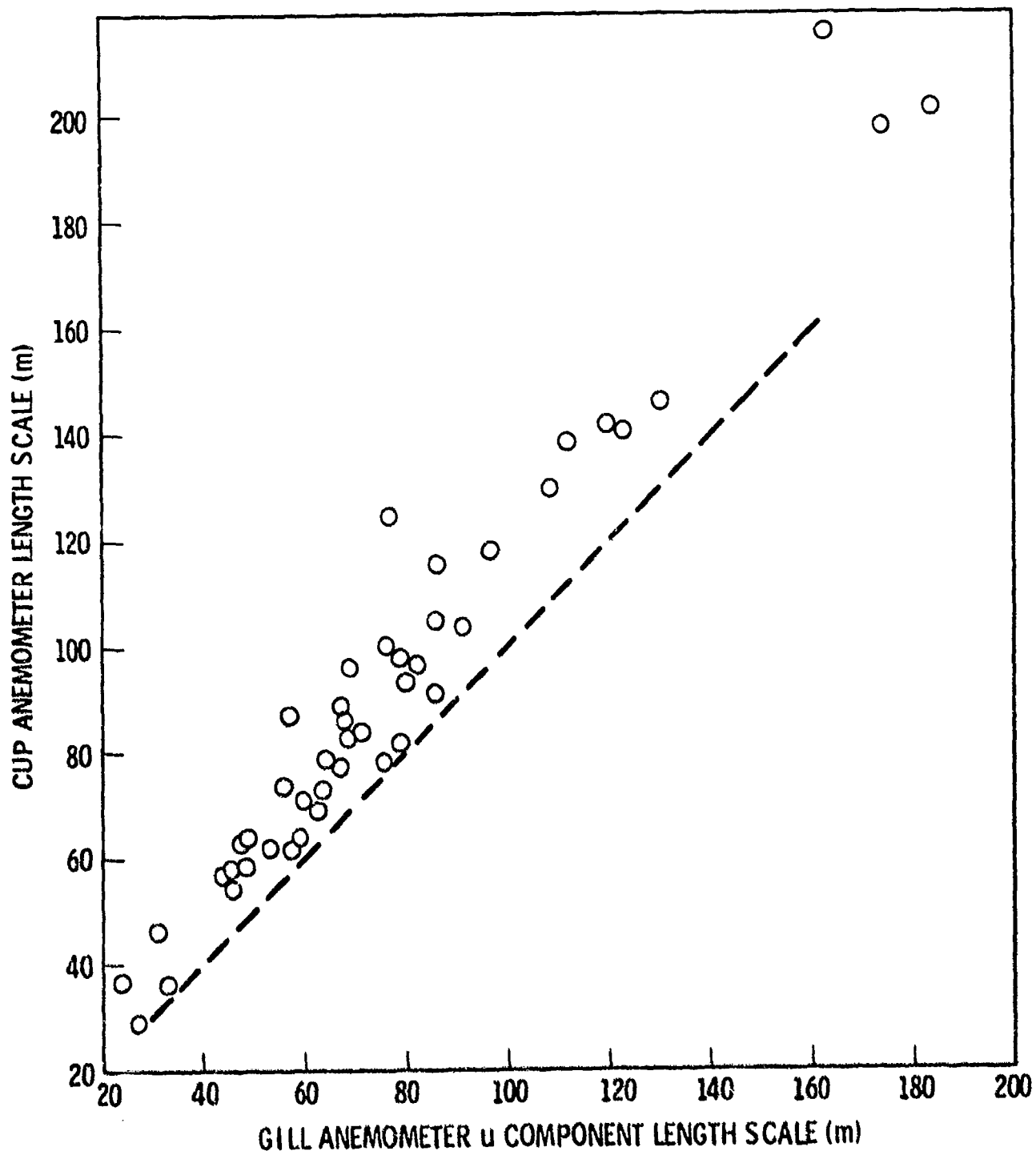

FIGURE 60. Comparison of longitudinal length scales (in m) determined from cup and Gill anemometer measurements.

(2-9) and (2-10).) The attenuation of the high frequency components of the time series causes the autocorrelation to decay more slowly than it should. Thus, the integral of autocorrelation with respect to time lags is larger than it would have been had the instrument response been better. This ultimately causes an overestimate of the length scale.

It is possible that this factor may have been the cause of the vertical length scales computed from the two lower level Gill anemometers at Lake Union being longer than those at other sites. If that is the case, the models in which vertical length scales are proportional to the height above the surface may be more realistic than that developed from the survey data. Examination of spectra for individual tests indicated that attenuation was not a serious problem, although that possibility cannot be eliminated entirely.

The longer length scales for the cup anemometer might also be attributed to its response to wind speed rather than to a single component of the wind vector. Finally, at low speeds the higher threshold and distance constant of the cup anemometer may have contributed to overestimation of length scales.

#### EVALUATION OF THE CUP ANEMOMETER

The standard airport cup anemometer was not designed as a turbulence sensor, but because it is a potential source of data on the climatology of turbulence, it has been compared with a Gill anemometer. Turbulence spectra obtained from the cup anemometer show attenuation at wave numbers corresponding to wave lengths of 100 m and very little response at wave lengths shorter than 10 m. It is possible in theory to correct the spectra for this attenuation. However, a better alternative is the use of the cup anemometers to provide

climatological estimates of the input parameters to turbulence models developed with other instruments.

Table 27 compares the mean values of the wind speed and turbulence model parameters obtained from measurements made with the Gill and cup anemometers during the intensive measurement periods. The table shows that the estimates of the average wind speed during the portion of the measurements analyzed are nearly identical. The difference in each case is of the order of the maximum resolution which could be obtained with the A-D converters interfaced with the NOVA computer.

TABLE 27. COMPARISON OF GILL AND CUP ANEMOMETER AVERAGE WIND SPEEDS AND TURBULENCE MODEL PARAMETER ESTIMATES

	Gill			Cup		
	$\bar{u}$ (m/s)	$\sigma_u$ (m/s)	$L_u$ (m)	$\bar{u}$ (m/s)	$\sigma_u$ (m/s)	$L_u$ (m)
Lake Union	4.22	1.23	72	4.20	1.25	86
KIXI	7.48	2.21	135	7.53	1.98	155
SEA-TAC	4.27	1.02	79	4.32	1.02	97

The same statement can be made for the average rms gust velocity estimates at Lake Union and SEA-TAC. At KIXI the cup anemometer estimates of the rms longitudinal gust velocity are about 10 percent lower than those from the Gill. However, since airport anemometers are typically installed near the ground rather than above tall buildings, the approximate equality of estimates at Lake Union and SEA-TAC are considered to be more significant than the difference at KIXI. The quality of rms gust velocity estimates at Lake Union and SEA-TAC should not be construed to mean that the instruments are equally good turbulence sensors. The comparison of the spectra in Figure 58

indicates otherwise. Rather, the conclusion which appears to be warranted is that the cup anemometers are capable of providing good estimates of rms gust velocities when used near ground level, and that a climatology of these estimates would be reasonably representative of measurements which might have been obtained using more sensitive turbulence instrumentation.

Finally, Table 27 shows that the cup anemometer data tend to give overestimates of the integral length scale. These overestimates are generally of the order of 20 percent. In reviewing data shown in Figure 60, it is seen that the overestimates are reasonably consistent. Thus, the cup anemometer can also be used to estimate length scales for climatological purposes, provided that the computed values are appropriately corrected. It may also be concluded that, with proper electronics and recording, the standard cup anemometer would provide information on turbulence which would be useful in an operational sense to tower operators, traffic control personnel and pilots.

## CHAPTER 13

### CONCLUSIONS

Motivated by a desire to ensure the safe and expeditious development of a short-haul air transportation system using V/STOL aircraft, the FAA has sponsored a study of potential meteorological problems associated with V/STOL aircraft terminal operations in a built-up urban environment. The initial portion of the study was an analysis aimed at identification of the meteorological information needed in:

- Selection of V/STOL port sites.
- Optimization of runway orientation at V/STOL ports.
- Determination of efficient and reliable methods of estimating climatological information on those meteorological variables significant to V/STOL operations at potential port sites.
- Optimization of a meteorological observation system for V/STOL ports.
- Establishment of airworthiness standards for V/STOL aircraft operations.
- Optimization of stability and control features for V/STOL aircraft.
- Simulation of V/STOL aircraft flight.
- Simulation of control of air traffic.

The availability and limitations of existing meteorological data were determined. At the conclusion of the initial phase

of the study, an Interim Report (Ramsdell and Powell, 1973) was prepared and a survey to obtain needed meteorological information was recommended.

Having now completed the measurement program and analysis of the data collected, it is appropriate to end this report with a review of both the results of the survey and the results of the study as a whole. Thus, the first portion of this chapter summarizes the results embodied in this report. The second portion of the chapter reviews the results of the study (both phases) as they relate to the initial objectives.

#### THE SURVEY

The primary purpose of the meteorological survey conducted in Seattle, Washington, was to obtain information on winds in general and turbulence in particular in the urban environment. Wind directions during the survey were distributed in a climatologically representative manner. Wind speeds, however, were significantly lower than expected. This did not seriously affect the results of the survey. Thus, it was concluded that the survey data are a consistent set which could be used to evaluate existing turbulence models and develop new ones.

Skepticism about the generality of the results of a single study of this nature is warranted. The results described herein have been compared with other data and models where possible. They are generally in excellent agreement with the other data. It is particularly significant that the survey data and the results obtained from their analysis are completely compatible with results of an extensive turbulence measurement program recently conducted in an urban area in Australia. The differences in the results are almost completely explained by the differences in wind speeds during the measurements.

## Major Conclusions

The data collected in the survey show that urban turbulence can be described in the context of conventional turbulence models developed from data obtained in past turbulence experiments conducted in more favorable terrain. The shapes of the power spectra obtained during the survey at both the urban and rural sites show marked similarities to each other and to atmospheric spectral models developed by others. That is not to say that the parameters of spectral models are the same in urban and rural areas, however.

Through examination of the scaling of the spectra in the frequency domain, it was found that only power spectra for the vertical velocity component scaled as a function of the non-dimensional frequency,  $nz/\bar{u}$ . The power spectra for the horizontal components were found to scale best as a function of  $n/\bar{u}$ . These conclusions were supported by the data analysis leading to the length scale models. The data from KIXI show that, in scaling the vertical velocity spectrum at elevated VTOL ports, the proper reference level is not the landing surface. Rather it is a lower level (in the case of the KIXI data, the ground level).

The behavior of the parameters of conventional spectral models, rms gust velocities and length scales, were examined at each of the sites. For a given set of meteorological conditions there was a wide variation in the observed values of these parameters. As a result, statistical models were developed to describe the observed variation.

The average rms gust velocities for all components of the wind were found to be linearly related to mean wind speed for wind speeds above 2 m/s. The parameters of this linear

relationship are a function of surface roughness, increasing as the roughness increases. The effects of the built-up urban area on turbulence were clearly evident in the rms gust velocities. The variation of rms gust velocities in a given set of meteorological conditions follows a log-normal distribution. This distribution is completely determined by the specification of a mean value and an rms value or variance. The mean has already been modeled. The data collected in the survey show that the rms value of the distribution is a function of roughness in the urban area. The values are low for flow across the built-up urban area and greater for flow over the smooth sectors. The SEA-TAC data did not show this variation in the width of the distribution. At all sites the widths of the distribution were independent of wind speed.

In the examination of turbulence length scales, effects of the built-up urban area were not identifiable. Average length scales and the distribution of observed values about these averages did not vary systematically with surface roughness (wind direction). Organization of the average length scale data designed to identify urban effects did, however, show that there was a fundamental difference in the behavior between the length scales for the horizontal components and those for the vertical component. The horizontal component length scales were primarily a function of wind speed. They were related to the height above ground only through the mean wind speed profile. The vertical component length scales, on the other hand, were primarily a function of height and only secondarily a function of wind speed. The behavior noted has been incorporated in a set of models for the average length scales. As with rms gust velocities, the length scales were found to be distributed log-normally. In this case, however, the widths of the distribution are essentially constant and independent of site, component and wind speed.

Isotropic relationships for the von Karman and Dryden turbulence models were examined using survey data. It is shown that the use of these relationships to estimate unknown rms gust velocities in flight simulation would lead to significant errors in the description of turbulence.

#### Additional Results

There are numerous results and conclusions of a subordinate nature which merit inclusion in this summary. These are related to: description of airflow in the urban boundary layer, effects of the length of observation on wind and turbulence parameters, spatial aspects of turbulence and wind shear, and wind instrumentation.

The survey wind measurements at Lake Union and SEA-TAC indicate that wind speeds at a typical urban V/STOL port site are about 10 percent lower than those at conventional airports in the same area. Further it seems reasonable, on the basis of the Lake Union data, to estimate the roughness length for wind profiles in the upper portion of the boundary layer as  $1/30$  the height of upwind buildings. In line with this rule of thumb, a reasonable roughness length for the Lake Union site during southerly winds is about 0.6 or 0.7 m.

Comparison of analyses of data from nearly concurrent wind observations made with the 2 data recording systems at Lake Union indicated that the length of observation period has a significant effect on horizontal component length scales. Short observation periods (5 min) did not provide a long enough record to properly estimate length scales for the horizontal turbulence components and resulted in underestimates. Long periods of observation (34 min) tend to overestimate these same length scales. Estimates of the vertical component length

scale, mean wind speed and rms gust velocities were not significantly affected by the length of the observation period.

Analysis of spatial turbulence data is a relatively recent undertaking. At the present time there are no standard analyses which provide results in a form usable in operational turbulence models for flight simulation. As a result, two possible approaches to analysis of this data were demonstrated. Space-time correlations were presented for 2 periods and vertical shear of the wind components was examined for 6 periods. In the last case, it was shown that momentary wind shear caused by turbulent fluctuations of the wind can exceed the shear of the mean wind.

As a side experiment, the FAA standard cup anemometer was evaluated as a sensor for use in collecting climatological turbulence data. The lack of responsiveness of the cup was shown to attenuate high frequency portions of the turbulence spectra. A transfer function was given which can partially correct this deficiency. Despite the attenuation of high frequency energy in the turbulence spectrum, the cup was shown to give a good estimate of the longitudinal rms gust velocity. The effect of the lack of responsiveness of the cup was more evident in the estimation of the longitudinal component length scale. It was consistently overestimated. As a whole, it was concluded that the cup anemometer could produce usable turbulence information for climatological and operational purposes.

Attempts to use sonic anemometers at Lake Union failed. This failure was apparently caused by a relatively strong electrical field at the site.

## THE STUDY

The objectives of the present study were listed in Chapter 1 of this report and repeated at the beginning of this chapter. In concluding this report and the study, it is appropriate to list each objective and give a cursory description of the results of the study applicable to the objective.

### Selection of V/STOL Port Sites

In the analysis leading to the Interim Report it was determined that meteorological information and techniques for estimating wind and turbulence at potential V/STOL port sites were inadequate. The initial result of the study applicable to this objective was the development of a rational technique for estimating wind roses at potential sites on the basis of extrapolation. This result was contained in the Interim Report. Many of the results in this report provide additional tools for use in estimating wind and turbulence climatologies at prospective V/STOL port sites. These results include the models relating turbulence gust velocities and length scales to surface roughness and wind speed, description of the probability distributions of turbulence parameters, and the comparison of wind and turbulence at typical urban V/STOL port sites at a conventional airport.

### Optimization of Runway Orientation

Meteorological information needed in optimization of runway orientation includes representative wind roses. Thus, the wind rose estimation procedure described in the Interim Report is directly applicable to this objective. In optimizing runway orientation at typical V/STOL port sites, it may be important to consider turbulence generated by the built-up urban

area. Thus, the turbulence models and probability distributions described in this report are also applicable. However, a technique to incorporate turbulence data in this optimization has yet to be developed.

#### Determination of Method of Estimating Climatological Information

In the analysis leading to the Interim Report, the existing climatological techniques for estimating and extrapolating climatological data on the basis of relatively short observation periods were found to be adequate for all meteorological elements of interest except wind. In that report a technique was outlined which would provide wind rose estimates at potential V/STOL port sites on the basis of relatively few measurements. That technique involves determining average differences in wind direction and speed and using Fourier series to model those differences. The turbulence models described in this report may be used with data contained in wind roses. Thus, this study has provided reasonable means of efficiently estimating climatologies of both mean winds and turbulence.

#### Optimization of A Meteorological Measurement System

In the course of the study it has become apparent that implementation of a short-haul transportation system using V/STOL aircraft is still several years in the future. A number of remote sensing meteorological instruments which might be included in an airport meteorological system are currently under development and were discussed in the Interim Report. In addition, V/STOL aircraft response to turbulence is still only marginally understood. As a result, no attempt was made to determine an optimum meteorological measurement system. However, those sections of this report and the Interim Report

which discuss instrumentation will be pertinent when an appropriate time comes to determine that system. The chapter on the standard cup anemometer will be particularly useful. Information in that chapter indicates that, with additional electronics, the cup anemometer can provide useful turbulence data.

#### Establishment of Airworthiness Standards

Airworthiness standards must be related to the aircraft operating environment. Thus, it is obvious that a description of the environment is necessary. Information existing during the initial analysis provided only a fragmentary description of wind and turbulence in the urban terminal environment of the proposed V/STOL transportation system. The data collected during the survey have provided a better description of this environment. Identification of the distributions of gust velocities and length scales as log-normal and development of models for these turbulence parameters are both significant contributions. With these results and a probability distribution for wind speed, it is now possible to estimate the probability of experiencing a given set of turbulence conditions in the urban environment. These probabilities will be needed in setting standards and in evaluating the parameters of turbulence models used in flight simulations submitted to demonstrate compliance with standards. The data presented on the spatial aspects of turbulence may also be applicable to establishment of airworthiness standards.

#### Optimization of Stability and Control Features

As in the establishment of airworthiness standards, the optimization of stability and control features of V/STOL aircraft requires an estimate of the operational environment.

The results of the survey are predominantly descriptions of a typical operating environment. Thus, they fulfill this objective of the study. The turbulence models and probability distributions provide a means of defining significant turbulence conditions or determining the probability of occurrence of postulated gust velocities and length scales. This application will require the use of a supplementary wind speed distribution. The discussion on spatial aspects of turbulence may also be of value in this area. Possibly, it will stimulate thought along the lines of useful spatial analysis and produce feedback for future data analysis. The results of the study are also applicable to the design of V/STOL stability and control features since they describe turbulence models for use in flight simulation to test various design alternatives.

#### Simulation of V/STOL Aircraft Flight

At the outset of the study there was no *a priori* reason for assuming that existing turbulence models used in flight simulation adequately described turbulence in an urban environment. Doubt existed as to the proper spectral shapes and to the appropriate values for parameters of the models. Data collected during the survey have led to improved spectral models and to a complete set of parameter models. It is no longer necessary to rely on tenuous theoretical relationships which exist at frequencies well above the response threshold of aircraft in determination of turbulence parameter values. Survey data show that isotropy relationships lead to significant errors in estimates of parameter values. There are indications that turbulence measurements may be used directly in future flight simulations rather than using turbulence models. Should this occur, the wind data themselves become a set of results applicable to flight simulation.

## Simulation of Control of Air Traffic

This study was primarily concerned with atmospheric conditions at altitudes of 200 ft and below. Meteorological information in this altitude band is of only marginal interest in air traffic control simulations. Generally, the meteorological conditions at these altitudes are of more concern to tower operators and pilots. The results of this study become of more interest in air traffic control simulation if the probability of a successful approach and landing can be related to wind and turbulence. Some possible relationships were indicated in the Interim Report using results of flight simulation studies, but the establishment of meaningful relationships between turbulence and missed approaches would require more study. These relationships, if real, could be combined with the results of the survey to provide estimates of the probability that an approach would be terminated by a missed approach rather than a landing. The discussion on spatial aspects of turbulence may be of some value; in particular, the partitioning of wind shear into mean and turbulent components may lead to better insight into the shear phenomenon actually affecting an aircraft.

### THE DATA LEGACY

The meteorological survey resulted in the collection of a large amount of data on the urban environment. The analysis of this data has been limited to that which was necessary to provide meaningful results in terms of the objectives of the study. The usefulness of the data are in no way limited in application to those objectives. As new problems arise or more refined answers are required for old problems, these data provide a ready source of information. The Appendices at the

end of this report contain summaries of analyzed data.

The detailed results presented in this report and the data contained in the Appendices are specifically intended for application to aeronautical problems. In a more general sense, the results of the study and the data should be of value to those interested in winds in the urban environment. The models and data contained herein may find immediate use in building design and air pollution control applications in addition to the aeronautical applications for which they were intended.

## REFERENCES

- N. M. Barr, D. Gangsaas and D. R. Schaeffer, 1974: Wind Models For Flight Simulator Certification of Landing and Approach Guidance and Control Systems, FAA-RD-74-206.
- S. Berman, 1965: "Estimating the Longitudinal Wind Spectrum Near the Ground," Quart. J. Roy. Meteor. Soc., 91, 302-317.
- A. B. Bernstein, 1967: "A Note on the Use of Cup Anemometers in Wind Profile Experiments," J. Appl. Meteor., 6, 280-286.
- N. E. Bowne and J. T. Ball, 1970: "Observational Comparison of Rural and Urban Boundary Layer Turbulence," J. Appl. Meteor., 9, 962-873.
- E. F. Bradley, 1968: "A Micrometeorological Study of Velocity Profiles and Surface Drag in the Region Modified by a Change in Surface Roughness," Quart. J. Roy. Meteor. Soc., 94, 361-379.
- R. R. Brook, 1972: "The Measurement of Turbulence in a City Environment," J. Appl. Meteor., 11, 443-450.
- R. R. Brook, 1974: A Study of Wind Structure in an Urban Environment, Meteorological Study No. 27, Australian Government Publishing Service, Canberra, Australia. 232 p.
- N. E. Busch and H. A. Panofsky, 1967: "Recent Spectra of Atmospheric Turbulence," Proc. Unguided Rocket Ballistics Meteorology Conference, New Mexico State University, 215-257.
- J. A. Businger, J. C. Wyngaard, Y. Izumi and E. F. Bradley, 1971: "Flux-Profile Relationships in the Atmospheric Surface Layer," J. Atmos. Sci., 28, 181-189.
- D. W. Camp, R. E. Turner and L. P. Gilchrist, 1970: "Response Tests on Cup, Vane and Propeller Wind Sensors," J. Geophys. Res., 75, 5265-5269.
- C. R. Chalk, D. A. DiFranco, J. V. LeVacqz and T. P. Neal, 1973: Revisions to MIL-F-8785B(ASG) Proposed by Cornell Aeronautical Laboratory Under Contract F33615-71-C-1254, AFFDL-TR-72-41, 259-273.

- A. G. Davenport, 1961: "The Spectrum of Horizontal Gustiness Near the Ground in High Winds," Quart. J. Roy. Meteor. Soc., 91, 194-211.
- R. Drinkow, 1972: "A Solution to the Paired Gill-Anemometer Response Function," J. Appl. Meteor., 11, 76-80.
- C. E. Duchon, F. V. Brock, M. Armendariz and J. D. Horn, 1972: UVW Anemometer Dynamic Performance Study, ECOM-5440, U.S. Army Electronics Command, 34 p.
- C. E. Elderkin, 1966: Experimental Investigation of the Turbulence Structure in the Lower Atmosphere, BNWL-329, Battelle, Pacific Northwest Laboratory, Richland, WA.
- C. E. Elderkin and D. C. Powell, 1971: "Measurements and Graphs of Turbulence Autocorrelations in Space and Time," in Proc. Symposium on Air Pollution, Turbulence and Diffusion, Las Cruces, New Mexico, December, 1971, H. W. Church and R. E. Luna, eds., 215-222.
- C. E. Elderkin, D. C. Powell, A. G. Dunbar and T. W. Horst, 1971: Take-Off and Landing Critical Atmospheric Turbulence (TOLCAT) Experimental Investigation, AFFDL-TR-70-117.
- C. E. Elderkin, D. C. Powell, A. G. Dunbar and T. W. Horst, 1972: Take-Off and Landing Critical Atmospheric Turbulence (TOLCAT) - Experiments and Analysis, AFFDL-TR-71-172.
- G. H. Fichtl, 1972: "Probability Distribution of Vertical Longitudinal Shear Fluctuations," J. Appl. Meteor., 11, 918-925.
- G. H. Fichtl and G. E. McVehil, 1970: "Longitudinal and Lateral Spectra of Turbulence in the Atmospheric Boundary Layer at the Kennedy Space Center," J. Appl. Meteor., 9, 51-63.
- G. H. Fichtl and P. Kumar, 1974: "The Response of a Propeller Anemometer to Turbulent Flow with the Mean Wind Vector Perpendicular to the Axis of Rotation," Boundary Layer Meteor., 6, 363-379.
- D. E. Gunter, G. W. Jones, J. W. Jones and K. R. Monson, 1969: Low Altitude Atmospheric Turbulence, Lo-Locat Phases I and II, ASD-TR-69-12.

- B. B. Hicks, 1972: "Propeller Anemometers as Sensors of Atmospheric Turbulence," Boundary Layer Meteor., 3, 214-228.
- R. M. Holmes, G. C. Gill and H. W. Carson, 1964: "A Propeller-Type Vertical Anemometer," J. Appl. Meteor., 3, 802-804.
- T. W. Horst, 1972: "A Computer Algorithm for Correcting Non-Cosine Response in the Gill Anemometer," Pacific Northwest Laboratory Annual Report for 1971 to the USAEC Division of Biology and Medicine, Vol. II: Physical Sciences, Part 1: Atmospheric Sciences, BNWL-1651-1, Battelle, Pacific Northwest Laboratories, Richland, WA. (Available from NTIS).
- T. W. Horst, 1973: "Corrections for Response Errors in a Three-Component Propeller Anemometer," J. Appl. Meteor., 12, 716-725.
- P. Hyson, 1972: "Cup Anemometer Response to Fluctuating Wind Speeds," J. Appl. Meteor., 11, 843-848.
- Y. Izumi and M. L. Barad, 1970: "Wind Speeds as Measured by Cup and Sonic Anemometers and Influenced by Tower Structure." J. Appl. Meteor., 9, 851-856.
- G. M. Jenkins and D. G. Watts, 1968: Spectral Analysis and Its Applications, Holden-Day, San Francisco, 525 p.
- J. C. Kaimal, 1972: "Turbulence Spectra, Length Scales and Structure Parameters in the Stable Surface Layer," paper presented at the IUCRM Colloquium on "Waves and Turbulence in Stable Layers and Their Effects on E&M Propagation," San Diego, CA, June 5-16. (Proceedings of Colloquium to be published in Boundary Layer Meteor.)
- P. Kumar, 1974: "Spectral Properties of Vertical Shear of Lateral Velocity," J. Appl. Meteor., 13, 237-241.
- J. K. Luers, 1973: A Model of Wind Shear and Turbulence in the Surface Boundary Layer, NASA-CR-2288.
- J. L. Lumley and H. A. Panofsky, 1964: The Structure of Atmospheric Turbulence, Interscience Publishers, John Wiley Co., New York, NY.
- P. B. MacCready, Jr., 1966: "Mean Wind Speed Measurements in Turbulence," J. Appl. Meteor., 5, 219-225.

- W.E.K. Middleton and A. F. Spilhaus, 1953: Meteorological Instruments, University of Toronto Press, 286 p.
- C. B. Notess, 1959: Analysis of Turbulence Data Measured in Flight at Altitudes up to 1600 Feet Above Three Different Types of Terrain, Cornell Aeronautical Laboratories Report No. TE-1215-F-1.
- A. M. Obukhov, 1971: "Turbulence in an Atmosphere with Non-uniform Temperature," (English translation of original) Boundary Layer Meteor., 2, 7-29.
- H. A. Panofsky, C. A. Mazzola, J. Woods and K. Eidsvik, 1970: Turbulence Characteristics over Heterogeneous Terrain, Research and Development Technical Report ECOM-0079-F, Pennsylvania State University, University Park, PA.
- H. A. Panofsky and R. A. McCormack, 1959: The Spectrum of Vertical Velocity Near the Surface, IAS Report No. 59-6.
- F. Pasquill, 1972: "Some Aspects of Boundary Layer Description," Quart. J. Roy. Meteor. Soc., 98, 469-494.
- C. A. Paulson, 1970: "The Mathematical Representation of Wind Speed and Temperature Profiles in the Unstable Atmospheric Surface Layer," J. Appl. Meteor., 9, 857-861.
- E. W. Peterson, 1969: "Modification of Mean Flow and Turbulent Energy by a Change in Surface Roughness Under Conditions of Neutral Stability," Quart. J. Roy Meteor. Soc., 95, 561-575.
- D. C. Powell, 1974: Analyses of Parallel and Orthogonal Wind Components Along Lines of Towers over Homogeneous Desert, PhD Dissertation, University of Utah. (Available on Microfilm.)
- J. V. Ramsdell and D. C. Powell, 1973: Meteorological Information for Vertical and Short Take-Off and Landing (V/STOL) Operations in Built-up Urban Areas - An Analysis, FAA-RD-72-135, 243 p.
- K. D. Saunders, 1961: B-66 Low-Level Gust Study, Vol. 1., Technical Analysis, WADD-TR-60-305.
- D Skibin, 1974: "Variation of Lateral Gustiness with Wind Speed," J. Appl. Meteor., 13, 654-657.
- D. Slade, Ed., 1968: Meteorology and Atomic Energy - 1968, U. S. Atomic Energy Commission, Division of Technical Information, TID-24190, Chap. 6.

- P. A. Taylor, 1969a: "Planetary Boundary Layer Above a Change in Surface Roughness," J. Atmos. Sci., 26, 432-440.
- P. A. Taylor, 1969b: "On Wind and Shear Stress Profiles Above a Change in Surface Roughness," Quart. J. Roy Meteor. Soc., 95, 77-91.
- H. W. Teunissen, 1970: Characteristics of the Mean Wind and Turbulence in the Planetary Boundary Layer, UTIAS Review No. 32, Institute for Aerospace Studies, University of Toronto, 45 p.
- U.S. Department of Commerce, National Weather Service, 1962: Climatology of the United States No. 82-45, Summary of Hourly Observations - Seattle, Washington, 15 p.
- U. S. Department of Transportation, Federal Aviation Administration, 1971: Automatic Landing Systems, AC 20-57A.
- E. K. Webb, 1955: Autocorrelations and Energy Spectra of Atmospheric Turbulence, CSIRO Div. Met. Phys. Tech. Paper No. 5, Melbourne, Australia.
- C. R. Wylie, Jr., 1966: Advanced Engineering Mathematics, 3rd Ed., McGraw-Hill, 813 p.

## APPENDIX A

### WIND ROSES

Appendix A contains the observed wind roses for the survey. Wind roses are included for all levels at each site. Thus, there are two wind roses for both SEA-TAC and KIXI and four for Lake Union. The number of observations included in each rose is given below the tabulation. The tabulations, themselves, are the percent of observations falling within a wind direction and speed category. All wind speeds are in meters/second and directions in degrees. It should be remembered that the wind direction is the direction from which the wind comes.

In the appendix the wind roses for Lake Union are given first. They are followed in order by those for KIXI and SEA-TAC.

LAKE UNION WIND ROSE, 6.9 m LEVEL

DIRN. (DEGS.)	<1	1-3	3-5	5-7	7-9	9-11	>11	TOTAL
345.75 TO 11.25	1.77	5.46	1.20	0.00	0.00	0.00	0.00	8.23
11.25 TO 33.75	1.32	6.70	1.53	.12	0.00	0.00	0.00	9.67
33.75 TO 56.25	2.44	5.54	.70	0.00	0.00	0.00	0.00	8.68
56.25 TO 78.75	1.74	1.61	.04	0.00	0.00	0.00	0.00	3.39
78.75 TO 101.25	1.41	.37	0.00	0.00	0.00	0.00	0.00	1.78
101.25 TO 123.75	1.16	.99	0.00	0.00	0.00	0.00	0.00	2.15
123.75 TO 146.25	.89	.74	0.00	0.00	0.00	0.00	0.00	1.74
146.25 TO 168.75	1.32	2.98	.17	0.00	0.00	0.00	0.00	4.46
168.75 TO 191.25	1.12	1.57	5.58	1.20	.04	0.00	0.00	15.54
191.25 TO 213.75	.74	5.41	5.91	1.20	.12	.08	0.00	14.47
213.75 TO 236.25	1.36	3.97	1.45	.04	.04	0.00	0.00	6.86
236.25 TO 258.75	.50	2.03	.45	0.00	0.00	0.00	0.00	2.98
258.75 TO 281.25	.45	1.98	.50	0.00	0.00	0.00	0.00	2.94
281.25 TO 303.75	.29	.79	.29	0.00	0.00	0.00	0.00	1.36
303.75 TO 326.25	.54	1.94	2.32	.50	.33	.08	0.00	5.70
326.25 TO 348.75	.44	3.25	2.94	1.24	.17	0.00	0.00	10.05
	17.40	54.32	23.07	4.30	.74	.17	0.00	100.00

TOTAL NO. OF OBSERVATIONS USED IN THIS TABLE = 2419.

LAKE UNION WIND ROSE, 12.6 + 17.1 m LEVEL

DIR. SECS.	<1	1-3	3-5	5-7	7-9	9-11	>11	TOTAL
345.75 TO 315.75	1.41	6.74	1.23	.35	.09	0.00	0.00	10.22
315.75 TO 285.75	1.50	6.26	1.59	.13	0.00	0.00	0.00	9.48
285.75 TO 255.75	2.34	4.85	.84	0.00	0.00	0.00	0.00	8.02
255.75 TO 225.75	.93	1.37	.09	0.00	0.00	0.00	0.00	2.38
225.75 TO 195.75	.44	.75	.04	0.00	0.00	0.00	0.00	1.63
195.75 TO 165.75	.74	1.19	.13	0.00	0.00	0.00	0.00	2.07
165.75 TO 135.75	1.28	.97	.04	0.00	0.00	0.00	0.00	2.29
135.75 TO 105.75	.93	3.22	.44	0.00	0.00	0.00	0.00	4.58
105.75 TO 75.75	1.10	7.54	6.26	2.69	.31	0.00	0.00	17.89
75.75 TO 45.75	.79	5.42	6.65	1.81	.31	.04	.04	15.07
45.75 TO 15.75	1.74	3.75	1.37	.18	0.00	0.00	0.00	6.35
15.75 TO 15.75	.86	2.12	.75	0.00	0.00	0.00	0.00	3.75
255.75 TO 225.75	.84	1.59	.09	0.00	0.00	0.00	0.00	2.51
225.75 TO 195.75	.44	.53	.57	0.00	0.00	0.00	0.00	1.06
195.75 TO 165.75	.53	1.41	2.38	.53	.18	0.00	0.00	5.02
165.75 TO 135.75	.57	3.57	1.98	1.37	.18	0.00	0.00	7.67
TOTAL	14.17	51.26	23.94	7.05	1.06	.04	.04	100.00

TOTAL NO. OF OBSERVATIONS USED IN THIS TABLE = 2269.

LAKE UNION WIND ROSE, 24-S M LEVEL

DIRN. (DEGS.)	01	1-3	3-5	5-7	7-9	9-11	211	TOTAL
348.75 TO 11.25	1.48	4.04	2.53	.63	0.00	0.00	0.00	9.56
11.25 TO 33.75	1.18	4.45	2.36	.13	.04	0.00	0.04	10.19
33.75 TO 56.25	1.14	5.27	2.40	.21	0.00	0.00	0.00	9.06
56.25 TO 78.75	.97	2.15	.67	.05	0.00	0.00	0.00	3.68
78.75 TO 101.25	.57	.76	.25	.04	0.00	0.00	0.00	1.73
101.25 TO 123.75	.55	.63	.17	.13	0.00	0.00	0.00	1.47
123.75 TO 146.25	.63	1.77	.42	0.00	1.00	0.00	0.00	2.82
146.25 TO 168.75	.43	2.25	1.60	.21	1.00	0.00	0.00	6.70
168.75 TO 191.25	1.01	4.68	6.02	3.50	1.01	.13	0.00	17.14
191.25 TO 213.75	.45	4.00	6.23	2.49	.68	.21	.04	14.41
213.75 TO 236.25	.97	3.33	1.30	.17	2.00	0.00	0.00	5.81
236.25 TO 258.75	.67	1.47	.59	.64	0.00	0.00	0.00	2.78
258.75 TO 281.25	.34	.60	0.00	0.00	0.00	0.00	0.00	1.18
281.25 TO 303.75	.20	.61	.08	0.00	2.00	0.00	0.00	.88
303.75 TO 326.25	.42	1.10	1.43	.88	0.00	0.00	0.00	3.83
326.25 TO 348.75	.50	2.74	3.20	1.52	.42	.05	0.00	8.55
TOTAL	17.22	44.78	30.16	10.93	1.36	.42	.04	100.00

TOTAL NO. OF OBSERVATIONS USED IN THIS TABLE = 2374.

LAKE UNION WIND ROSE, 48.2 m LEVEL

DIRN. (DEGS.)	<1	1-3	3-5	5-7	7-9	9-11	>11	TOTAL
348.75 TO 11.25	.53	5.65	2.56	1.38	.13	0.00	0.00	10.26
11.25 TO 33.75	.85	3.62	1.91	.39	0.00	0.00	0.00	6.77
33.75 TO 56.25	.72	3.29	2.89	.26	0.00	0.00	0.00	7.17
56.25 TO 78.75	.39	1.45	.85	.20	0.00	0.00	0.00	2.89
78.75 TO 101.25	.33	.72	.07	.07	0.00	0.00	0.00	1.18
101.25 TO 123.75	.33	.20	0.00	0.00	.07	0.00	.07	.66
123.75 TO 146.25	.33	.66	.46	.07	0.00	0.00	.07	1.58
146.25 TO 168.75	.30	1.45	1.78	.33	.26	0.00	.07	4.27
168.75 TO 191.25	.46	.92	3.42	6.90	3.55	1.18	.13	16.57
191.25 TO 213.75	.45	2.10	5.46	5.00	1.25	.46	.20	15.32
213.75 TO 236.25	.59	4.40	2.36	1.05	.20	0.00	0.00	8.81
236.25 TO 258.75	.30	2.50	1.12	.13	0.00	0.00	0.00	4.14
258.75 TO 281.25	.45	1.14	0.00	0.00	0.00	0.00	0.00	2.04
281.25 TO 303.75	.30	.39	.07	0.00	0.00	0.00	0.00	.85
303.75 TO 326.25	.50	1.71	1.84	.72	0.00	0.00	0.00	4.87
326.25 TO 348.75	.53	4.21	4.93	2.30	.59	.07	0.00	12.62
TOTAL	9.55	34.45	29.91	18.80	6.05	1.71	.53	100.00

TOTAL NO. OF OBSERVATIONS USED IN THIS TABLE = 1521.

KIXI WIND ROSE, 77.1 m LEVEL.

DIRM. (DEGS.)	<1	1-3	3-5	5-7	7-9	9-11	>11	TOTAL
368.75 TO 11.25	1.10	6.03	5.72	1.89	.43	.12	0.00	15.28
11.25 TO 33.75	.37	4.14	3.65	1.28	.12	0.00	0.00	9.56
33.75 TO 56.25	.43	2.01	1.89	.61	.06	0.00	0.00	4.99
56.25 TO 78.75	.85	.97	1.03	.30	.06	0.00	0.00	3.23
78.75 TO 101.25	1.52	1.46	.55	.12	0.00	0.00	0.00	3.65
101.25 TO 123.75	.61	.61	.30	.12	0.00	0.00	0.00	1.64
123.75 TO 146.25	.37	1.89	1.89	.79	.30	0.00	0.00	5.23
146.25 TO 168.75	.12	2.31	5.48	2.74	.30	.06	0.00	11.02
168.75 TO 191.25	.79	1.77	3.41	1.46	1.52	.18	0.00	9.13
191.25 TO 213.75	.30	3.23	4.50	1.10	.06	0.00	0.00	9.19
213.75 TO 236.25	.73	2.43	2.43	.79	.37	.06	.06	6.88
236.25 TO 258.75	1.03	3.04	.55	0.00	0.00	0.00	0.00	4.63
258.75 TO 281.25	2.62	3.71	.06	0.00	0.00	0.00	0.00	6.39
281.25 TO 303.75	.43	.73	.06	0.00	0.00	0.00	0.00	1.22
303.75 TO 326.25	.18	.37	.37	.37	.12	0.00	0.00	1.40
326.25 TO 348.75	.66	1.34	2.01	1.95	1.10	.12	0.00	6.57
	11.50	36.03	33.90	13.51	4.44	.55	.06	100.00

TOTAL NO. OF OBSERVATIONS USED IN THIS TABLE = 1643.

KIXI WIND ROSE, 95.4 m LEVEL

DIRN, (DEGS.)	<1	1-3	3-5	5-7	7-9	9-11	>11	TOTAL
348.75 TO 11.25	1.20	6.25	5.85	2.40	.27	.13	0.00	16.10
11.25 TO 33.75	.73	4.79	2.73	.60	0.00	0.00	0.00	8.65
33.75 TO 56.25	.27	2.13	1.53	.40	0.00	0.00	0.00	4.32
56.25 TO 78.75	.60	.47	.60	.27	0.00	0.00	0.00	2.13
78.75 TO 101.25	.67	.67	.40	.07	0.00	0.00	0.00	1.60
101.25 TO 123.75	.27	.86	.33	.07	0.00	0.00	0.00	1.73
123.75 TO 146.25	.27	2.20	1.73	.67	.83	0.00	0.00	5.39
146.25 TO 168.75	.67	2.40	5.59	2.13	.27	0.00	0.00	10.84
168.75 TO 191.25	.86	4.13	5.19	2.13	.80	0.00	.07	13.17
191.25 TO 213.75	.60	3.19	4.46	1.60	.20	.13	.07	10.25
213.75 TO 236.25	.67	2.66	1.00	.20	.07	0.00	0.00	4.59
236.25 TO 258.75	.80	4.06	.53	0.00	0.00	0.00	0.00	5.39
258.75 TO 281.25	.93	2.40	0.00	0.00	0.00	0.00	0.00	3.33
281.25 TO 303.75	.53	1.13	.07	0.00	0.00	0.00	0.00	1.73
303.75 TO 326.25	.67	.53	.47	.60	.07	0.00	0.00	2.13
326.25 TO 348.75	.53	2.06	2.93	1.73	1.40	0.00	0.00	6.65
	9.65	39.92	33.60	12.84	3.59	.27	.13	100.00

TOTAL NO. OF OBSERVATIONS USED IN THIS TABLE = 1503.

SEA-TAC WIND ROSE, 7.1 m LEVEL

DIRN. (DEGS.)	<1	1-3	3-5	5-7	7-9	9-11	>11	TOTAL
3-8.75 TO 11.75	1.73	4.90	2.14	.21	0.10	0.00	0.00	8.98
11.25 TO 33.75	.58	3.09	3.25	.54	.04	0.00	0.00	7.50
33.75 TO 56.25	.41	1.61	1.19	.33	.04	.08	0.00	3.67
56.25 TO 78.75	.41	1.07	.41	0.00	0.00	0.00	0.00	1.89
78.75 TO 101.25	.62	1.40	.54	0.00	0.00	0.00	0.00	2.64
101.25 TO 123.75	.54	3.50	.58	.49	.12	0.00	0.00	5.23
123.75 TO 146.25	.41	3.62	.66	.16	.04	0.00	0.00	5.40
146.25 TO 168.75	1.36	5.15	1.36	.29	0.10	0.00	0.00	8.15
168.75 TO 191.25	1.85	5.56	3.42	1.24	.29	.08	.08	12.52
191.25 TO 213.75	.49	4.78	5.31	2.02	.62	0.00	0.00	13.22
213.75 TO 236.25	.62	4.53	4.00	1.48	.41	0.00	.04	11.08
236.25 TO 258.75	.66	2.27	.86	.08	.04	0.00	0.00	3.91
258.75 TO 281.25	.70	2.43	.54	.04	0.00	0.00	0.00	3.71
281.25 TO 303.75	.41	2.35	.99	0.00	0.00	0.00	0.00	3.75
303.75 TO 326.25	.41	2.51	.62	.08	.12	0.00	0.00	3.75
326.25 TO 348.75	.99	2.84	.66	.08	.04	0.00	0.00	4.61
	12.69	51.69	26.52	7.04	1.77	.16	.12	100.00

TOTAL NO. OF OBSERVATIONS USED IN THIS TABLE = 2428.

SEA-TAC WIND ROSE, 27.0 m LEVEL

DIRM. (DEGS.)	<1	1-3	3-5	5-7	7-9	9-11	>11	TOTAL
2-8.75 TO 11.25	.33	3.92	3.75	.25	.74	0.00	0.00	8.30
11.25 TO 33.75	.42	2.88	3.29	1.54	.29	0.00	0.00	8.42
33.75 TO 54.25	.13	1.50	1.13	.67	.04	.08	.04	3.59
54.25 TO 78.75	.17	1.08	.71	.17	0.00	0.00	0.00	2.13
78.75 TO 101.25	.63	1.04	.54	.29	0.00	0.00	0.00	2.50
101.25 TO 123.75	.46	2.79	.88	.17	.42	.08	0.00	4.80
123.75 TO 146.25	.42	4.05	.83	.25	.08	0.00	0.00	5.63
146.25 TO 164.75	.38	4.75	1.50	.17	.04	0.00	0.00	6.84
164.75 TO 191.25	.96	5.34	4.30	1.88	.79	.25	.13	13.64
191.25 TO 213.75	.54	4.75	5.05	2.63	1.00	.08	0.00	14.05
213.75 TO 236.25	.42	3.75	4.21	1.75	.14	.08	.04	10.80
236.25 TO 258.75	.33	2.71	1.29	.08	.14	0.00	0.00	4.46
258.75 TO 281.25	.58	2.17	.63	.04	0.00	0.00	0.00	3.34
281.25 TO 303.75	.25	2.04	1.38	.04	0.00	0.00	0.00	3.71
303.75 TO 326.25	.21	2.21	1.13	.08	.13	.04	0.00	3.79
326.25 TO 348.75	.33	2.29	.96	.29	.18	.04	0.00	4.00
	6.46	47.29	31.57	10.30	3.10	.67	.21	100.00

TOTAL NO. OF OBSERVATIONS USED IN THIS TABLE = 2398.

## APPENDIX B

### INTENSIVE MEASUREMENT PROGRAM DATA SUMMARY

Appendix B contains a summary of the data from the intensive measurement program. The data are presented by site, experiment, and level of measurement. This information is contained in the first 14 characters. The first 4 characters identify the site, original data file, and segment within the file. The Lake Union data start with a numeral, those from KIXI with the letter K and the SEA-TAC data with the letters St. The 10 numerals which follow give the date and time of the beginning of the data segment which is summarized and the instrument locations. This group is subdivided as follows: the first 4 numerals give the month and day, the next 4 the time, and the last 2 the tower and level. The numbering of measurement levels starts at the lowest level and increases upward.

The data from the Gill anemometer at the level are summarized in 9 groups following the identification. The data in these groups are, in order: wind speed, longitudinal rms gust velocity, longitudinal length scale, lateral rms gust velocity, lateral length scale, mean vertical velocity, vertical rms gust velocity, vertical length scale, and wind direction. Wind speed, rms gust velocity and length scale for the cup anemometer are given in the additional groups included for the lowest measurement level. All wind speeds and gust velocities are given in meters/second, length scales in meters and wind direction in degrees relative to true north.

LAKE UNION INTENSIVE MEASUREMENT PROGRAM DATA SUMMARY

1-1	0706105071	3.88	1.17	68.	1.48	155.	.029	.625	14.7	197	3.91	1.13	89.
1-1	0706105072	4.27	1.21	93.	1.40	211.	.237	.800	18.4	196			
1-1	0706105073	4.82	1.24	99.	1.41	207.	.077	.851	18.3	197			
1-1	0706105074	5.60	1.17	105.	1.50	302.	.006	.673	49.3	202			
1-2	0710092571	5.67	1.43	48.	1.49	138.	.068	.825	11.9	198	5.75	1.37	63.
1-2	0710092572	6.10	1.48	143.	1.52	151.	.312	.980	11.0	198			
1-2	0710092573	7.00	1.68	243.	1.51	176.	.0201	.045	17.5	199			
1-2	0710092574	8.61	1.67	360.	1.47	222.	.152	.749	47.4	202			
1-3	0711114071	6.38	1.09	112.	1.18	151.	.168	.455	15.3	330	3.84	.93	59.
1-3	0711114072	6.89	1.12	107.	1.22	216.	.455	.539	27.6	334			
1-3	0711114073	7.34	1.01	90.	1.11	245.	.614	.554	27.1	334			
1-3	0711114074	7.59	.86	100.	1.21	205.	-.491	.511	38.0	334			
2-2	1023112571	2.65	.91	67.	.73	50.	.054	.456	12.2	184	2.60	.94	77.
2-2	1023112572	2.98	.92	76.	.75	56.	.009	.544	14.0	183			
2-2	1023112573	3.88	1.03	96.	.86	57.	-.057	.617	22.5	184			
2-2	1023112574	4.30	1.15	104.	.81	68.	-.031	.538	31.0	184			
2-3	1023171071	4.52	1.40	76.	1.15	59.	.107	.731	13.1	194	4.73	1.45	100.
2-3	1023171072	5.07	1.41	82.	1.16	65.	.139	.837	16.2	191			
2-3	1023171073	6.47	1.66	99.	1.40	56.	.1191	.038	16.2	191			
2-3	1023171074	7.25	1.73	150.	.97	97.	-.338	.876	23.5	190			
2-4	1024075571	4.75	1.62	79.	1.24	33.	.045	.770	11.9	189	5.23	1.64	98.
2-4	1024075572	5.77	1.70	96.	1.28	37.	.048	.931	15.6	188			
2-4	1024075573	6.95	1.79	118.	1.37	39.	.0321	.126	20.8	190			
2-4	1024075574	7.90	1.78	129.	1.14	58.	-.2291	.034	38.7	190			
3-1	1029172571	4.90	1.30	64.	1.09	51.	-.012	.634	9.3	185	4.91	1.28	73.
3-1	1029172572	4.87	1.23	62.	.95	35.	-.056	.805	12.2	184			
3-1	1029172573	6.63	1.53	86.	.78	30.	-.198	.912	22.5	183			
3-1	1029172574	7.36	1.42	110.	1.12	43.	-.043	.734	43.4	186			
3-2	1031170871	3.95	1.51	62.	1.13	64.	.330	.518	17.4	355	5.40	1.75	146.
3-2	1031170872	4.68	1.79	71.	1.14	72.	.277	.719	13.1	351			
3-2	1031170873	5.88	1.96	140.	1.31	95.	.430	.927	37.0	351			
3-2	1031170874	6.84	1.97	237.	1.42	131.	-.336	.733	47.2	353			
3-4	1101150271	2.78	.95	33.	.51	47.	.012	.116	16.1	347	1.92	.92	36.
3-4	1101150272	3.07	.95	67.	.50	56.	.125	.331	9.5	344			
3-4	1101150273	3.25	.81	54.	.55	49.	.277	.410	14.0	348			
3-4	1101150274	3.60	.70	86.	.41	40.	-.210	.310	18.0	350			
3-5	1103112971	2.63	1.33	57.	1.44	68.	-.033	.805	17.1	156	2.75	1.27	87.
3-5	1103112972	2.81	1.38	81.	1.28	68.	-.1801	.017	21.6	158			
3-5	1103112973	3.84	1.60	120.	1.39	58.	-.3781	.317	34.6	158			
3-5	1103112974	5.06	2.11	184.	1.37	46.	-.069	.908	74.9	151			
4-11	1115100071	4.73	1.24	64.	.94	24.	-.060	.712	10.9	184	4.60	1.20	79.
4-11	1115100072	5.14	1.27	63.	1.02	25.	-.110	.854	12.3	183			
4-11	1115100073	6.32	1.40	100.	1.16	33.	-.156	.950	13.9	183			
4-11	1115100074	7.32	1.37	104.	.80	37.	.062	.751	37.3	182			
4-12	1115113071	4.14	1.12	56.	1.00	41.	-.053	.606	10.4	185	4.01	1.09	74.
4-12	1115113072	4.51	1.15	87.	.99	56.	-.100	.715	15.8	184			
4-12	1115113073	5.47	1.40	119.	1.03	146.	-.182	.802	28.4	184			
4-12	1115113074	6.09	1.42	90.	.67	105.	.010	.703	25.0	184			
4-13	1115131571	2.69	.93	69.	.77	47.	.067	.406	12.4	194	2.46	1.00	83.

LAKE UNION INTENSIVE MEASUREMENT PROGRAM DATA SUMMARY (continued)

4-131115131572	2.99	.96	101.	.89	41.	.083	.505	13.8	196			
4-131115131573	3.67	1.06	108.	.93	53.	.078	.658	25.0	196			
4-131115131574	3.88	1.06	105.	.58	79.	-.182	.509	32.2	191			
5-111120103871	3.69	1.22	49.	.83	27.	.039	.546	6.3	182	3.86	1.25	64.
5-111120103871	4.14	1.30	88.	.95	43.	-.049	.714	11.6	182			
5-111120103871	5.21	1.59	93.	1.08	47.	-.101	.820	19.3	182			
5-111120103871	6.00	1.55	74.	.81	59.	-.015	.735	24.0	182			
5-211121113471	2.67	.84	46.	.76	37.	.122	.371	14.7	208	2.65	.86	55.
5-211121113472	3.12	.87	50.	.78	47.	.128	.479	16.2	212			
5-211121113473	3.60	.89	75.	.81	95.	.089	.526	21.2	211			
5-211121113474	3.25	.72	73.	.61	94.	.134	.359	29.6	204			
6-111128131071	4.07	1.42	86.	1.20	73.	.141	.563	13.8	202	4.47	1.54	105.
6-111128131072	4.57	1.43	101.	1.26	80.	.193	.804	21.0	203			
6-111128131073	5.57	1.70	134.	1.27	81.	.108	.983	22.8	199			
6-111128131074	6.30	1.81	147.	1.03	152.	.120	.920	32.1	196			
6-121128145071	4.69	1.41	68.	1.07	38.	.097	.609	5.6	188	5.18	1.44	86.
6-121128145072	5.47	1.43	64.	1.22	31.	.092	.897	11.4	188			
6-121128145073	6.91	1.73	120.	1.06	34.	.0451	.029	23.0	187			
6-121128145074	7.86	1.64	119.	.71	43.	.2311	.033	43.4	187			
7-111126190071	2.91	.78	27.	.49	15.	.083	.376	13.0	180	2.62	.79	29.
7-111126190072	3.31	.84	35.	.56	16.	.050	.484	13.6	182			
7-111126190073	4.06	.86	61.	.68	23.	.017	.568	11.0	182			
7-111126190074	4.47	.92	91.	.59	30.	.042	.362	20.1	181			
7-211127090971	4.53	1.31	184.	.82	25.	.057	.644	15.9	184	4.46	1.28	202.
7-211127090972	5.22	1.44	233.	.93	38.	-.036	.808	25.1	184			
7-211127090973	6.28	1.45	220.	1.12	35.	-.166	.919	26.4	183			
7-211127090974	7.17	1.44	153.	.97	109.	-.046	.782	27.2	182			
7-311127160471	6.34	1.97	112.	1.34	49.	.087	.876	9.5	187	6.52	2.00	139.
7-311127160472	7.35	2.22	152.	1.48	49.	.0591	.105	11.8	187			
7-311127160473	8.73	2.43	196.	1.41	60.	-.0951	.210	16.6	188			
7-311127160474	10.15	2.34	229.	1.15	106.	.0011	.283	30.4	189			
8-111206143071	2.74	.91	24.	1.00	41.	-.026	.516	10.2	163	2.41	.98	37.
8-111206143072	3.22	1.10	32.	1.10	38.	-.125	.712	23.9	162			
8-111206143073	4.17	1.06	76.	1.15	47.	-.118	.788	20.6	165			
8-111206143074	5.32	1.19	78.	.91	57.	-.003	.590	20.0	174			
8-211211124071	4.70	1.57	130.	1.13	49.	-.001	.695	10.1	186	4.71	1.63	146.
8-211211124072	5.03	1.62	101.	1.29	97.	-.034	.851	13.0	186			
8-211211124073	5.48	1.94	132.	1.39	72.	-.1091	.052	10.2	186			
8-211211124074	7.37	2.12	273.	.83	83.	.061	.932	31.0	184			
8-221211138671	4.32	1.23	46.	.61	41.	.015	.654	6.9	179	4.64	1.21	58.
8-221211138672	5.01	1.25	45.	1.13	24.	-.092	.868	11.0	178			
8-221211138673	6.25	1.46	73.	1.16	24.	-.1721	.067	16.9	177			
8-221211138674	7.11	1.62	100.	.88	34.	-.068	.826	30.6	177			
8-221211153671	4.33	1.22	46.	.90	40.	.010	.655	6.9	179	4.65	1.21	58.
8-221211153672	5.91	1.25	45.	1.13	24.	-.096	.868	11.0	178			
8-221211153673	6.32	1.45	67.	1.15	23.	-.1641	.062	16.8	177			
8-221211153674	7.09	1.61	98.	.88	33.	-.064	.827	25.1	177			
8-231211174671	6.72	2.29	173.	1.50	54.	.0931	.002	11.4	188	7.20	2.37	198.
8-231211174672	7.75	2.43	174.	1.94	53.	.1031	.336	14.7	188			

LAKE UNION INTENSIVE MEASUREMENT PROGRAM DATA SUMMARY (continued)

8-231211174673	9.34	2.73	160.	1.87	66.-	.0261.677	21.5	188			
8-231211174674	11.03	2.89	215.	1.42	89.-	.0831.371	39.7	187			
8-241211193071	7.91	2.64	84.	1.99	33.	.1981.254	13.4	189	8.52	2.75	116.
8-241211193072	8.62	2.75	103.	2.18	51.	.1791.566	17.2	190			
8-241211193073	10.58	3.17	127.	2.03	85.	.0101.816	23.3	188			
8-241211193074	12.41	3.47	213.	2.01	74.	.1331.577	52.1	188			
8-251211213071	8.59	3.00	123.	2.17	50.	.1221.308	11.7	189	9.28	3.07	141.
8-251211213072	8.91	2.95	121.	2.24	41.	.0491.604	16.0	189			
8-251211213073	11.47	3.38	173.	2.44	71.-	.1442.042	24.1	190			
8-251211213074	13.80	3.43	221.	2.49	80.-	.0472.052	27.6	190			
823A1211174671	6.74	2.32	174.	1.59	54.	.0921.002	10.8	188	7.20	2.37	198.
823A1211174672	7.75	2.53	170.	1.94	57.	.1131.330	14.7	188			
823A1211174673	9.37	2.75	186.	1.88	65.-	.0111.653	22.5	188			
823A1211174674	11.04	2.89	215.	1.44	88.	.0821.381	39.7	186			
824A1211193071	7.7	2.70	86.	2.02	34.	.1881.274	13.5	189	8.53	2.77	116.
824A1211193072	8.68	2.81	103.	2.23	57.	.1851.596	15.6	190			
824A1211193073	10.66	3.24	131.	2.08	83.	.0181.882	20.3	188			
824A1211193074	12.48	3.49	222.	2.00	72.	.1461.604	17.4	188			
825A1211213071	8.66	3.06	120.	2.18	48.	.1151.356	10.4	189	9.29	3.08	142.
825A1211213072	9.00	2.99	130.	2.24	40.	.0391.643	14.4	189			
825A1211213073	11.57	3.39	187.	2.47	75.-	.1352.067	22.0	190			
825A1211213074	13.91	3.42	224.	2.47	83.-	.0252.073	25.0	190			
9-211213190571	3.66	1.14	62.	.53	24.	.150 .469	12.1	187	3.40	1.14	69.
9-211213190572	4.24	1.21	70.	.76	32.	.017 .644	17.0	184			
9-211213190573	4.76	1.12	64.	.74	43.-	.012 .748	20.0	184			
9-211213190574	5.54	1.17	71.	.59	87.	.044 .471	17.7	182			
9-211219081771	1.44	.75	60.	.30	27.	.139 .182	3.5	018	1.33	.87	71.
9-211219081772	1.63	.80	76.	.39	38.	.130 .273	9.1	019			
9-211219081773	1.79	.75	93.	.45	59.	.154 .336	3.4	019			
9-211219081774	2.18	.69	152.	.36	63.	.051 .357	10.7	013			
10111219200071	2.12	.76	76.	.60	44.	.126 .259	8.5	194	1.51	.99	78.
10111219200072	2.54	.86	104.	.69	59.	.142 .366	17.0	196			
10111219200073	2.95	.95	64.	.61	49.	.119 .458	11.8	193			
10111219200074	3.12	.97	57.	.46	23.	.145 .494	15.6	190			
10121219012071	2.54	.92	31.	.44	46.	.130 .347	6.4	185	1.98	1.16	46.
10121219012072	2.88	1.02	46.	.54	46.	.105 .444	6.9	183			
10121219012073	3.20	1.19	67.	.74	46.	.059 .571	9.0	176			
10121219012074	3.78	1.42	83.	.58	25.	.009 .548	13.6	172			
11111220160871	4.61	1.18	44.	1.05	50.	.177 .638	9.2	210	4.72	1.15	57.
11111220160872	5.45	1.22	50.	1.18	68.	.173 .794	10.9	211			
11111220160873	6.16	1.28	52.	1.28	100.	.129 .983	11.1	214			
11111220160874	6.39	1.21	63.	1.20	143.	.126 .892	16.0	212			
12110113180071	4.74	1.48	40.	1.01	36.	.246 .680	7.6	185	4.82	1.50	93.
12110113180072	5.43	1.58	47.	1.12	25.	.135 .855	15.2	187			
12110113180073	6.40	1.64	109.	1.28	38.	.0351.001	20.5	191			
12110113180074	7.56	1.63	135.	1.08	47.	.146 .843	35.5	192			
121A0113202071	4.23	1.37	49.	.95	37.	.204 .615	11.0	186	4.30	1.37	59.
121A0113202072	4.80	1.52	65.	.96	39.	.150 .794	19.7	187			
121A0113202073	5.80	1.68	66.	1.05	31.	.108 .941	29.6	189			

LAKE UNION INTENSIVE MEASUREMENT PROGRAM DATA SUMMARY (continued)

12120113202074	6.74	1.74	86.	.83	33.	.236	.611	35.0	188			
12120113222071	4.22	1.27	50.	.94	36.	.203	.614	11.0	186	4.29	1.37	60.
12120113222072	4.80	1.52	67.	.96	39.	.148	.793	20.1	187			
12120113222073	5.79	1.68	69.	1.05	31.	.106	.938	29.5	189			
12120113222074	6.74	1.74	86.	.83	33.	.237	.811	35.0	188			
12130113232071	4.55	1.31	72.	.84	22.	.095	.668	9.6	180	4.49	1.27	84.
12130113232072	5.23	1.49	98.	1.00	25.	-.099	.887	16.7	180			
12130113232073	6.25	1.54	149.	1.13	28.	-.069	.981	18.8	181			
12130113232074	7.49	1.48	197.	1.16	40.	.046	.817	45.7	182			
12140114022071	3.46	1.21	86.	.74	17.	.132	.539	8.3	174	3.29	1.20	91.
12140114022072	3.98	1.28	90.	.78	24.	.027	.678	10.3	174			
12140114022073	4.94	1.41	45.	1.11	23.	-.010	.838	18.3	173			
12140114022074	6.41	1.33	43.	1.22	33.	.092	.740	28.2	176			
12150114052071	.75	.50	26.	.44	53.	.061	.208	6.9	159	.24	.42	6.
12150114052072	1.00	.60	38.	.51	68.	.014	.290	13.2	162			
12150114052073	1.50	.68	67.	.80	65.	-.033	.392	16.4	155			
12150114052074	1.95	.84	105.	.91	59.	-.006	.358	16.8	154			
13110114074071	6.44	1.80	81.	1.30	33.	.264	.923	9.0	186	6.76	1.77	97.
13110114074072	7.33	2.03	103.	1.29	34.	.082	1.139	11.0	186			
13110114074073	8.98	2.07	178.	1.53	36.	-.027	1.256	17.1	190			
13110114074074	10.12	2.17	262.	.98	46.	.142	1.229	27.3	189			

KIXI AND SEA-TAC INTENSIVE MEASUREMENT PROGRAM DATA SUMMARY

K1-11031172401	9.90	1.92	340.	1.42	124.	1.065	.867	40.6	336	8.91	1.61	337.
K1-11031172402	9.42	1.55	270.	1.18	90.	.6641	.168	45.2	338			
K2-11115112901	3.21	1.44	97.	1.12	33.	.028	.697	21.5	185	3.32	1.25	118.
K2-11115112902	3.79	1.45	117.	.95	41.	-.2021	.037	36.3	182			
K2-21115121101	4.53	1.39	53.	1.39	41.	.269	.913	20.4	181	4.55	1.11	62.
K2-21115121102	5.29	1.56	88.	1.40	40.	-.0281	.725	27.0	181			
K2-31115130601	4.53	1.22	58.	1.08	31.	.279	.837	22.6	168	4.37	1.00	62.
K2-31115130602	5.11	1.41	61.	.95	42.	.0321	.052	30.1	169			
K3-11127160501	9.60	2.35	123.	2.40	41.	.2101	.418	27.8	181	9.82	2.23	141.
K3-11127160502	10.55	2.43	96.	2.39	41.	-.5961	.967	31.6	180			
K4-11128103201	7.40	2.34	79.	2.09	36.	.2631	.390	17.8	185	7.41	1.96	82.
K4-11128103202	8.60	2.63	73.	2.20	39.	-.1991	.889	25.8	186			
K4-21128125901	5.98	2.42	270.	1.88	42.	.0821	.143	24.5	185	6.07	2.18	299.
K4-21128125902	6.66	2.54	228.	1.87	41.	-.3021	.680	44.0	184			
K4-31128143101	7.17	2.05	91.	1.54	57.	.0901	.194	24.4	182	6.96	1.74	104.
K4-31128143102	7.85	2.09	116.	1.70	35.	-.5611	.651	34.5	182			
K5-11211153701	9.03	3.22	162.	2.68	42.	.4621	.665	23.8	177	10.30	3.09	216.
K5-11211153702	8.95	2.05	81.	3.62	85.	-.0832	.440	21.5	9999			
K5-21211173701	12.50	3.72	77.	3.63	34.	.1692	.165	27.7	178	13.60	3.67	125.
K5-21211173702	12.65	3.53	82.	3.57	37.	-.6123	.081	34.2	9999			

ST-11115112501	4.50	1.18	59.	1.01	46.	.272	.495	16.5	174	4.63	1.17	64.
ST-11115112502	4.70	1.29	52.	1.01	35.	.127	.571	24.4	175			
ST-21115120601	4.04	1.20	109.	1.09	39.	.257	.566	15.8	181	4.98	1.18	130.
ST-21115120602	5.32	1.28	123.	1.11	32.	.155	.652	27.1	178			
ST-31115130901	3.28	.68	69.	.63	50.	.225	.306	12.5	166	3.35	.71	96.
ST-31115130902	3.45	.80	43.	.59	20.	.117	.382	19.7	166			

## APPENDIX C

### INTENSIVE MEASUREMENT PROGRAM SPECTRA

The individual wind component power spectral estimates for those intensive measurement periods analyzed are presented in Appendix C. The banded power spectral estimates for each test are contained on cards. This Appendix is a listing of those cards. Due to the number of spectral estimates obtained, 2 cards are required for each component. Thus, for Lake Union 26 cards are required for each test. For the KIXI and SEA-TAC tests 14 cards are required.

On the spectral cards the identification field has been extended to 15 columns from the 14 used for the data summary cards listed in Appendix B. The information in the first 14 columns is the same as on the data summary cards. At each level the spectral cards are numbered to identify the component and frequencies contained. This number appears in column 15. There are 8 cards for the lowest level at each site and 6 cards for each of the upper levels. Cards 1 and 2 contain the power spectral data for the Gill anemometer u component; those numbered 2 and 3 contain v component data, and those numbered 5 and 6 contain w component data. At the lowest levels at each site the cards numbered 7 and 8 contain data from the cup anemometer.

On the odd numbered cards the data contained in columns 16-20 and 21-25 are the mean wind speed and component variance in m/s and  $(m/s)^2$ , respectively. These 2 fields are in F5.2 and F5.3 format. The mean wind speeds are derived from the Gill anemometer except for those given on card 7 which are

for the cup. All variances are those computed following detrending and tapering of data.

The spectral estimates are given in columns 26-80 of the odd numbered cards and columns 16-80 of the even numbered cards. The spectral estimates which have been normalized to the component variance start with the highest frequency band and work toward lower frequencies. The center of the highest frequency band at Lake Union is 1.125 Hz with the center of each succeeding band reduced by 75 percent. For example, the spectral estimates on card 1 are for 11 frequency band centered at 1.125, 0.844, 0.633, 0.474, 0.356, 0.266, 0.200, 0.150, 0.112, 0.0844, 0.0633 and 0.0474 Hz, respectively. On the even numbered cards the first frequency band is centered at 0.0356 Hz and the last at 0.00150 Hz. In three tests (1-3, 3-2 and 3-4) only 2048 data points were analyzed. For these tests the lowest frequency band for which spectral estimates are given is 0.00266 Hz.

The sampling rates at KIXI and SEA-TAC were somewhat greater than 2 Hz, therefore, the center frequencies of the spectral bands start at 1.227 Hz and decrease to 0.0690 Hz on the first card for each component. On the second card they decrease from 0.0518 to 0.00164 Hz.

LAKE UNION INTENSIVE MEASUREMENT PROGRAM POWER SPECTRA

1-1	07061050711	3.881	.258	.0749	.0225	.0265	.0322	.0431	.0606	.0716	.0607	.1013	.1130	.1305
1-1	07061050712	1.393	.2028	.1850	.2035	.2894	.1799	.0943	.2121	.2260	.4630	.2323	.1388	.0502
1-1	07061050713	3.891	.996	.0106	.0090	.0126	.0163	.0223	.0251	.0340	.0399	.0550	.0556	.0688
1-1	07061050714	.0728	.0739	.0947	.1154	.1475	.1264	.2553	.2798	.1752	.1873	.4651	.4765	.2330
1-1	07061050715	3.88	.3714	.0317	.0191	.0283	.0350	.0531	.0712	.0841	.0862	.1016	.1010	.0750
1-1	07061050716	1.021	.0840	.0013	.0547	.0442	.0648	.0357	.0420	.0282	.0281	.0057	.0027	.0059
1-1	07061050717	3.911	.164	.0039	.0027	.0032	.0045	.0063	.0104	.0194	.0267	.0620	.0872	.1208
1-1	07061050719	1.584	.2236	.1906	.2085	.3502	.2588	.1144	.2312	.3558	.6333	.3838	.1839	.1149
1-1	07061050721	4.271	.275	.0289	.0223	.0242	.0312	.0423	.0509	.0658	.0816	.1040	.1119	.1578
1-1	07061050722	1.142	.2194	.1533	.1067	.2710	.1431	.0373	.1911	.1813	.4679	.3593	.2035	.0929
1-1	07061050723	4.271	.751	.0118	.0111	.0137	.0148	.2716	.0340	.0391	.0424	.0595	.0575	.0625
1-1	07061050724	.0949	.0727	.1062	.0776	.0680	.1221	.2910	.1765	.1281	.2447	.3218	.4163	.2350
1-1	07061050725	4.27	.5977	.0657	.0440	.0579	.0752	.1145	.1251	.1623	.2529	.3292	.2448	.2857
1-1	07061050726	.2389	.2781	.2412	.1861	.1931	.1692	.0733	.1068	.0774	.0530	.0225	.0310	.0464
1-1	07061050731	4.271	.305	.0322	.0240	.0238	.0312	.0395	.0430	.0720	.0744	.0847	.0872	.1286
1-1	07061050732	1.175	.1641	.1984	.2067	.2825	.1818	.0360	.1859	.2133	.4325	.3578	.2407	.0837
1-1	07061050733	4.831	.758	.0705	.0149	.0159	.0198	.0240	.0275	.0398	.0462	.0566	.0709	.0767
1-1	07061050734	.0000	.0480	.0025	.1401	.0028	.1524	.2708	.2202	.1507	.2529	.2275	.3426	.2520
1-1	07061050735	4.83	.6678	.0467	.0507	.0559	.0757	.1172	.1457	.1874	.2273	.2566	.2141	.2944
1-1	07061050736	.2520	.2629	.2393	.1773	.2009	.1762	.0851	.0986	.0368	.0489	.0212	.0467	.0500
1-1	07061050741	5.421	.204	.0240	.0206	.0239	.0207	.0334	.0433	.0521	.0729	.0896	.0880	.0900
1-1	07061050742	1.145	.1267	.2278	.2313	.1660	.3653	.1472	.2054	.2103	.2857	.0500	.3336	.2212
1-1	07061050743	5.421	.987	.0140	.0115	.0136	.0157	.0220	.1343	.0457	.0531	.0507	.0588	.0748
1-1	07061050744	.0842	.1092	.0865	.1185	.1222	.1020	.1754	.2561	.2136	.1493	.1531	.2141	.1972
1-1	07061050745	5.42	.3992	.0972	.0971	.0975	.0914	.0587	.0834	.1286	.1436	.1671	.1901	.1880
1-1	07061050746	2.195	.2797	.1940	.2021	.2814	.2340	.1496	.1381	.0861	.1827	.1549	.1443	.0589
1-2	07100925711	5.421	.904	.0427	.0429	.0490	.0599	.0711	.0921	.0912	.1202	.1197	.1750	.2380
1-2	07100925712	1.484	.1897	.3231	.1388	.1515	.0140	.2563	.1812	.1998	.0884	.0566	.0231	.0300
1-2	07100925713	5.421	.836	.0470	.0336	.0399	.0480	.0607	.1000	.1127	.0965	.1221	.1284	.1304
1-2	07100925714	1.054	.1515	.1604	.1720	.1808	.2537	.0960	.1902	.1471	.2571	.2891	.3055	.1032
1-2	07100925715	5.42	.4209	.1289	.1076	.1332	.1020	.1739	.2219	.1782	.2816	.3070	.2636	.2588
1-2	07100925716	2.467	.3382	.1386	.1140	.0946	.1240	.0773	.0671	.0494	.0063	.0357	.0300	.0070
1-2	07100925717	5.421	.750	.0374	.0067	.0065	.0132	.0200	.0407	.0564	.1070	.1500	.2603	.4169
1-2	07100925718	1.232	.3301	.4906	.3674	.1049	.0087	.5472	.1007	.5741	.1916	.1116	.0779	.0494
1-2	07100925719	4.122	.030	.0422	.0379	.0410	.0437	.0555	.0736	.0787	.1038	.1070	.1667	.1078
1-2	07100925722	1.682	.2457	.1484	.1140	.1529	.0501	.1932	.1015	.2077	.1115	.0444	.0280	.0756
1-2	07100925723	4.101	.845	.0371	.0282	.0328	.0624	.0505	.0591	.0856	.0944	.1065	.1213	.1473
1-2	07100925726	2.151	.1046	.1439	.1098	.2282	.2486	.0703	.150	.1866	.2605	.2273	.3005	.2286
1-2	07100925729	6.10	.8944	.0917	.0727	.1029	.1259	.1730	.2155	.2319	.2674	.3152	.1878	.2780
1-2	07100925724	.2502	.2165	.1302	.1300	.0742	.1027	.0304	.0306	.0510	.0148	.0177	.0179	.0076
1-2	07100925721	7.302	.927	.0324	.0207	.0336	.0624	.0207	.0562	.0810	.0786	.0000	.1268	.1221
1-2	07100925722	1.524	.1420	.1872	.1005	.1474	.3996	.2120	.1778	.2810	.0004	.0512	.0574	.0084
1-2	07100925723	7.301	.877	.0430	.0440	.0472	.0573	.0668	.0405	.0864	.1058	.1138	.1789	.0841
1-2	07100925724	1.717	.1912	.1428	.1669	.1810	.1470	.1927	.1122	.2020	.3076	.2234	.2569	.2165
1-2	07100925725	7.301	.025	.1028	.0956	.1054	.1353	.1931	.2264	.2404	.2590	.3093	.3017	.3190
1-2	07100925726	.2074	.2102	.1223	.1212	.0732	.1638	.0619	.0791	.0251	.0180	.0164	.0128	.0037
1-2	07100925741	8.412	.208	.0212	.0242	.0256	.0300	.0363	.0493	.0627	.0553	.0705	.1078	.0902
1-2	07100925742	.0751	.1410	.1311	.1829	.1854	.2409	.2327	.3620	.3508	.1536	.0685	.0188	.0620
1-2	07100925743	8.411	.573	.0540	.0372	.0393	.0440	.0501	.0806	.0894	.0994	.1412	.1087	.1453

LAKE UNION INTENSIVE MEASUREMENT PROGRAM POWER SPECTRA (continued)

1-2 07100925744.1072.1958.1509.2793.1945.2383.1607.0604.1652.1911.1904.2919.2498  
 1-2 07100925745 8.61.5293.0774.0788.0794.0997.1406.1405.1552.1802.2107.2660.2363  
 1-2 07100925746.3263.3154.1548.1507.1217.2027.0918.2531.1352.0748.0332.0278.0247  
 1-3 07111140711 6.381.021.0354.0355.0519.0891.0887.0866.0904.1292.1174.0890.1380  
 1-3 07111140712.1055.0979.3341.1445.3283.1785.0995.0855.1468.4076  
 1-3 07111140713 6.381.241.0462.0407.0507.0533.0595.0731.0731.0889.0868.1080.0987  
 1-3 07111140714.0627.1215.1355.1088.2302.3532.3071.1967.1846.1435  
 1-3 07111140715 6.38.1988.2542.2434.2398.2117.3098.3477.3900.2213.1795.1143.2109  
 1-3 07111140716.1135.0644.1104.1138.1256.0914.0418.0535.0776.0383  
 1-3 07111140717 3.84.7901.0071.0078.0105.0142.0223.0480.0492.1020.1576.1709.2256  
 1-3 07111140718.3192.2227.1595.1492.2110.2163.1388.0498.0559.1243  
 1-2 07111140721 6.821.038.0362.0309.0430.0460.0527.0585.0480.1010.0719.1512.1269  
 1-3 07111140722.1550.1657.2815.2725.4199.2796.1312.0733.1562.3798  
 1-3 07111140723 6.891.455.0349.0377.0441.0520.0638.0581.0491.0794.0830.0969.0961  
 1-3 07111140724.0959.0723.1494.0981.2216.2971.1932.1573.2121.1926  
 1-3 07111140725 6.89.2778.0917.0885.1233.1635.2174.2468.2920.2175.2316.2726.2382  
 1-3 07111140726.1460.1755.1802.1141.1874.0715.0557.1645.1676.0525  
 1-3 07111140731 7.24.8259.0412.0239.0389.0485.0472.0928.0924.1243.1375.1670.1362  
 1-3 07111140732.0879.1368.2372.1781.4705.3314.2181.0898.1508.2878  
 1-3 07111140733 7.241.017.0489.0464.0459.0493.0569.0519.0476.0683.0902.0669.0789  
 1-3 07111140734.1204.0679.1156.0928.2474.2425.1405.1382.2284.2553  
 1-3 07111140735 7.34.3067.0954.0761.0932.1227.1534.1949.2463.2181.1884.3751.3049  
 1-3 07111140736.1303.1803.2397.1404.3171.1089.1165.0959.0463.0100  
 1-3 07111140741 7.59.5687.0322.0361.0435.0477.0567.0757.0759.0990.1392.2014.1029  
 1-3 07111140742.1467.1708.2850.1542.2397.3671.3472.1387.1811.2451  
 1-2 07111140743 7.591.275.0302.0256.0285.0381.0446.0606.0598.0696.1120.0683.0883  
 1-3 07111140744.1312.0850.2775.2298.3156.2839.1799.1531.1865.2016  
 1-3 07111140745 7.59.2505.0837.0622.0658.0658.0825.0936.1245.1556.2061.2110.2900  
 1-3 07111140746.1728.3904.2714.2272.5101.2150.1249.0881.0593.0217  
 2-2 10231125711 2.65.7711.0505.0359.0322.0314.0330.0442.0634.0668.0624.0714.1347  
 2-2 10231125712.0635.1210.1980.1557.2381.2540.1996.1453.2521.1163.2433.2480.3006  
 2-2 10231125713 2.65.5192.0788.0644.0557.0434.0494.0694.0810.0779.0768.1245.0936  
 2-2 10231125714.1210.1571.1549.1368.2199.1808.1761.2411.3928.5704.1581.1212.1121  
 2-2 10231125715 2.65.1955.1018.0759.0768.0860.0960.1313.1849.2077.2824.3773.2516  
 2-2 10231125716.1664.1864.3354.2168.1257.1171.1179.0426.0794.0304.0766.0522.0339  
 2-2 10231125717 2.60.8110.0243.0195.0147.0119.0090.0093.0104.0139.0207.0348.0675  
 2-2 10231125718.0374.0820.1625.1328.2047.2529.1789.1180.2541.0791.2256.2237.2752  
 2-2 10231125721 2.98.7812.0456.0337.0307.0262.0406.0454.0445.0521.0721.0691.0647  
 2-2 10231125722.1084.1527.1947.1346.2021.2921.2007.1208.2765.1203.3241.3802.2732  
 2-2 10231125723 2.98.5410.0741.0687.0572.0550.0554.0677.0666.0771.0881.1128.1246  
 2-2 10231125724.1303.2107.0909.1590.2804.2246.0883.2238.3825.4752.2770.1304.1075  
 2-2 10231125725 2.98.2750.0560.0533.0494.0680.0884.1440.3019.2001.3006.3135.2654  
 2-2 10231125726.2217.2675.2928.1557.1083.1361.1303.0654.1100.0692.0713.0450.0151  
 2-2 10231125731 3.88.8709.0513.0497.0429.0421.0530.0556.0686.0595.0736.0728.1174  
 2-2 10231125732.1138.1280.1645.2021.1981.1264.1102.1688.2339.2120.2540.3610.3156  
 2-2 10231125733 3.88.6678.0937.0860.0631.0669.0641.0775.0801.0864.1104.1396.2360  
 2-2 10231125734.1495.2575.1507.2275.2135.1301.1484.1961.1802.1875.2125.2231.1556  
 2-2 10231125735 3.88.3476.0975.0868.0799.0947.1182.1241.1832.2023.2411.2969.2809  
 2-2 10231125736.2152.2773.1862.1649.1099.1221.0852.1911.0962.0820.0503.0388.0386

LAKE UNION INTENSIVE MEASUREMENT PROGRAM POWER SPECTRA (continued)

2-2 10231125741 4.301.015.0.59.0396.0375.0383.0362.0463.0555.0550.0711.0875.1046  
 2-2 10231125742 0.856.1095.1547.2685.1115.0932.2328.2238.1926.3344.5078.2681.1723  
 2-2 10231125743 4.30.5821.1412.0813.0686.0620.0613.0714.0686.0758.0949.1067.1650  
 2-2 10231125744 1.036.1742.2227.2142.1206.1438.1482.3721.2167.0566.2149.3014.1799  
 2-2 10231125745 4.30.2720.1064.0932.0817.0747.0884.0872.1167.1629.1757.1977.2403  
 2-2 10231125746 2224.2945.1660.2029.1642.1546.1208.2102.0774.1297.1348.0558.0567  
 2-2 10231710711 4.521.675.0614.0381.0407.0407.0640.0531.0751.0933.1001.1171.1499  
 2-2 10231710712 1.204.1858.2385.2666.2832.1513.1528.0860.1632.4617.2536.0111.0586  
 2-2 10231710713 4.521.141.0643.0552.0540.0664.0786.0895.1046.1065.1493.2166.2052  
 2-2 10231710714 1.622.2187.2523.2006.3034.2273.1820.0960.1312.1246.0735.0662.0271  
 2-2 10231710715 4.52.4905.1244.0815.0987.1759.1645.2267.2955.2623.2962.1969.2962  
 2-2 10231710716 2.512.2640.1629.1829.1205.0940.1101.0385.1130.0759.0253.0147.0126  
 2-2 10231710717 4.741.728.0754.0231.0181.0154.0238.0240.0406.0745.0957.1598.2612  
 2-2 10231710718 1.789.2930.5086.5024.5595.3285.2560.1832.2642.9354.5214.0364.1193  
 2-2 10231710721 5.071.616.0429.0419.0442.0476.0527.0722.0911.0710.1131.0970.1543  
 2-2 10231710722 1.654.2478.3076.2498.3362.1353.0944.0691.1329.3436.1889.0297.0563  
 2-2 10231710723 5.071.186.0774.0525.0599.0594.0857.1033.1314.1602.1271.1941.2046  
 2-2 10231710724 1.482.2891.2505.1976.3705.2054.1786.0723.0803.0226.0799.0714.0155  
 2-2 10231710725 5.27.7295.0910.0742.0908.1175.1791.2195.2553.2445.2886.2043.3120  
 2-2 10231710726 2.543.2453.1633.1760.0954.1641.1217.0358.0793.0604.0316.0184.0279  
 2-2 10231710731 6.472.193.0535.0450.0472.0495.0572.0739.0763.0734.0867.1771.1596  
 2-2 10231710732 1.273.2028.2413.2108.2139.2521.1740.0770.1327.2756.1161.0428.0468  
 2-2 10231710733 6.471.70.0880.0648.0712.0785.1024.1077.1018.1499.1828.2142.2467  
 2-2 10231710734 2.569.1763.2243.2187.1891.2184.1665.1552.1497.1416.0836.0560.0068  
 2-2 10231710735 6.47.9326.1483.1001.1030.1298.1629.1935.1978.2483.1541.2639.2945  
 2-2 10231710736 3.279.2301.2315.1452.1112.1139.0869.0321.0652.0259.0168.0206.0148  
 2-2 10231710741 7.352.340.0516.0437.0395.0482.0537.0555.0599.0837.0975.1079.1395  
 2-2 10231710742 1.511.1689.2095.2709.1361.1450.2121.2727.2996.2196.0554.0092.0141  
 2-2 10231710743 7.25.7615.1232.0817.0687.0830.0817.0905.1071.1364.1480.1660.1644  
 2-2 10231710744 2.124.2280.3194.2815.2831.2279.2073.2212.0763.0460.0300.0218.0298  
 2-2 10231710745 7.25.0865.0725.0565.0578.0690.0902.0980.1559.1246.2028.1705.0688  
 2-2 10231710746 2.023.1550.1884.1802.0653.0649.0620.0335.0774.0067.0160.0209.0131  
 2-4 10240755711 4.752.525.0419.0295.0332.0373.0366.0461.0601.0618.0832.1348.1190  
 2-4 10240755712 2.070.1279.2069.1841.1688.2032.1728.1635.5025.1467.2417.1592.0996  
 2-4 10240755713 4.751.371.0709.0610.0564.0666.0767.1100.1324.1706.1597.1571.1827  
 2-4 10240755714 2.026.1744.2184.2488.2941.1449.3944.1489.0972.1285.0493.0451.0293  
 2-4 10240755715 4.75.5459.1334.1125.1140.1609.1870.2545.3143.2664.2881.2937.2642  
 2-4 10240755716 2.592.2012.2441.1394.0480.0661.0528.0475.0427.0085.0368.0244.0066  
 2-4 10240755717 5.232.593.0260.0214.0192.0216.0216.0304.0564.0757.1350.2700.2940  
 2-4 10240755718 5.044.2893.5746.5146.5407.5846.5382.4532.1464.4222.7218.4452.2942  
 2-4 10240755721 5.712.741.0374.0335.0379.0393.0482.0563.0708.0718.1104.1336.0880  
 2-4 10240755722 2.755.1181.2037.2528.1578.1799.1177.1433.4327.1443.2465.1452.1199  
 2-4 10240755723 5.211.506.0821.0629.0681.0778.0998.1203.1350.1465.1549.2031.1848  
 2-4 10240755724 2.520.1954.1833.2420.2478.1275.3943.1022.1102.1316.0401.0292.0321  
 2-4 10240755725 5.72.9197.1020.0850.0241.1473.1582.2070.2408.2495.2650.3099.1999  
 2-4 10240755726 3.764.2143.2920.1712.0927.0628.0627.0623.0499.0265.0178.0143.0127  
 2-4 10240755731 6.953.057.0614.0345.0364.0436.0532.0660.0737.0828.0791.1012.1098  
 2-4 10240755732 2.146.1923.2166.3027.1507.1635.1375.0821.3908.2037.2850.1504.1273  
 2-4 10240755733 6.951.710.0916.0783.0849.0900.1110.1237.1402.1603.1666.2588.2823

LAKE UNION INTENSIVE MEASUREMENT PROGRAM POWER SPECTRA (continued)

2-4	10240755734	2591	2264	1653	1824	1563	1772	4213	0737	0748	0679	0135	0079	0048
2-4	10240755735	5.951	193	1337	1011	1118	1396	1595	2026	2332	2030	2335	2580	2395
2-4	10240755736	3184	2880	2004	2137	1105	0835	0430	1102	0410	0226	0240	0374	0200
2-4	10240755741	7.903	025	0448	0365	0396	0415	0550	0582	0681	0844	0804	1111	0936
2-4	10240755742	1002	1417	1321	4807	1518	2052	2527	1423	2975	1418	1350	1425	1312
2-4	10240755743	7.001	187	0894	0689	0658	0707	0834	1210	1249	1309	2205	1688	1930
2-4	10240755744	1762	1714	2477	1702	3753	5306	1741	1033	0746	0613	0335	0062	0076
2-4	10240755745	7.901	105	1041	0774	0948	1008	1212	1531	1486	2433	2518	2736	2615
2-4	10240755746	2314	2130	1804	1980	1057	1230	0642	2876	1468	0139	0166	0178	0115
3-1	10291725711	4.901	562	0623	0394	0425	0547	0630	0708	0810	1182	1265	1903	1713
3-1	10291725712	1942	2266	1345	1835	2827	0842	2454	2578	1843	2179	2778	0646	0541
3-1	10291725713	4.901	023	0478	0479	0346	0703	0814	1007	1089	1495	1306	1669	1580
3-1	10291725714	2729	3531	3823	2181	2314	2914	1154	1079	0983	0093	0237	0150	0368
3-1	10291725715	4.90	4638	1323	0254	1082	1304	1929	2253	2979	3159	2469	3937	2637
3-1	10291725716	2454	1773	1346	1770	1465	0720	0683	0346	0400	0225	0268	0091	0032
3-1	10291725717	4.901	494	0223	0178	0147	0140	0191	0218	0381	0730	1134	1911	2562
3-1	10291725718	2787	3629	2490	3452	5002	1767	4405	5405	3141	3865	4621	1032	0897
3-1	10291725721	4.961	412	0657	0427	0388	0501	0547	0758	0832	0876	0903	1139	1230
3-1	10291725722	2028	2809	1741	1326	2672	1021	3133	2604	2465	1780	2298	0461	0543
3-1	10291725723	4.96	7773	0882	0570	0594	0767	0948	1014	1130	1557	1849	2483	1758
3-1	10291725724	2784	2776	3610	1824	1870	2972	2119	1662	0736	0313	0379	0089	0187
3-1	10291725725	4.84	4264	0956	0920	0932	1332	1711	2276	2542	2659	3075	3550	3114
3-1	10291725726	2520	1779	1058	1429	1293	1014	1448	0410	0430	0179	0145	0028	0056
3-1	10291725731	6.622	126	0371	0229	0412	0367	0485	0575	0680	0756	0960	0974	0964
3-1	10291725732	1310	1732	2236	2128	1720	1511	4311	3689	1925	1627	1903	0299	0700
3-1	10291725733	6.63	5254	1629	1101	0854	0921	0974	1102	1121	1441	2017	2119	1864
3-1	10291725734	2435	1876	2903	2506	2448	2869	3050	1021	0535	0461	0462	0102	0210
3-1	10291725735	6.63	7992	1379	0268	1075	1251	1505	1929	2241	1882	2714	2597	2957
3-1	10291725736	2722	2372	1684	1185	1208	1965	1652	0689	0471	0446	0444	0051	0112
3-1	10291725741	7.261	815	0394	0428	0409	0463	0549	0648	0647	0916	0852	1123	1529
3-1	10291725742	1316	1719	1253	2330	2024	1551	2424	4022	1445	3797	3888	0151	0468
3-1	10291725743	7.341	165	0413	0579	0544	0669	0895	1025	1329	1597	1868	1837	2301
3-1	10291725744	2729	2285	3910	2401	2047	2267	2395	1487	1049	1458	1475	0420	0228
3-1	10291725745	7.34	5004	1165	0929	0763	0922	1125	1766	2094	1915	1775	2028	2758
3-1	10291725746	1742	3012	2052	1483	2050	1527	0931	1507	0901	1227	1293	0264	0454
3-2	10311708711	3.951	827	0530	0510	0160	0758	0211	1225	1492	1356	1543	2239	1680
3-2	10311708712	1834	1070	1125	1756	1577	1757	2685	2923	1383	1806			
3-2	10311708713	3.951	202	0715	0549	0575	0632	0622	1748	0751	0974	0725	1440	1922
3-2	10311708714	1574	1583	1396	1510	2754	2917	4238	1312	0862	1736			
3-2	10311708715	3.95	2918	1476	1222	1489	1532	2007	2777	2392	2670	2577	2544	2642
3-2	10311708716	2018	1450	1328	0992	1028	1144	1597	1930	0483	0391			
3-2	10311708717	5.802	249	0343	0218	0251	0295	0402	1677	1044	1382	1480	1803	3317
3-2	10311708718	6534	6232	6549	4112	8779	4242	3861	2824	1132	1423			
3-2	10311708721	4.882	511	0415	0450	0475	0652	0927	0957	1381	1563	1399	1069	1012
3-2	10311708722	1724	1191	1421	1641	2583	1562	2975	1541	0784	1217			
3-2	10311708723	4.681	244	0657	0710	0950	0765	0777	0570	1012	1145	1310	1222	1859
3-2	10311708724	1642	0875	1062	1208	2722	2022	3809	1108	1386	1712			
3-2	10311708725	4.49	5181	0414	0451	0535	0756	0267	0934	1160	1337	1573	1347	1033
3-2	10311708726	1577	1109	1345	1116	0549	0267	0605	0419	0412	0156			

LAKE UNION INTENSIVE MEASUREMENT PROGRAM POWER SPECTRA (continued)

3-2	10311708731	5.882	.760	.0436	.0456	.0474	.0482	.0652	.0776	.0696	1175.1586.1522.1786
3-2	10311708732	1.182	.1837	.1558	.2260	.2264	.1472	.2692	.1909	.0439	0475
3-2	10311708733	5.881	.627	.0651	.0718	.0738	.0836	.0961	.0611	.1209	1110.1007.1764.1348
3-2	10311708734	2.396	.2185	.1729	.1129	.2323	.1681	.2066	.2273	.2076	1591
3-2	10311708735	5.88	.8056	.0810	.0696	.0970	.1346	.1291	.1250	.1534	2077.3034.2958.1090
3-2	10311708736	3.423	.1498	.2086	.3425	.2171	.0650	.0939	.1219	.1373	0380
3-2	10311708741	6.843	.155	.0426	.0363	.0379	.0447	.0545	.0679	.0838	0757.1063.1087.1354
3-2	10311708742	.0956	.1199	.1291	.1012	.1314	.1551	.2434	.1168	.0880	1079
3-2	10311708743	6.841	.864	.0413	.0543	.0589	.0504	.0666	.0963	.1236	0971.1263.0984.1038
3-2	10311708744	2.905	.2536	.2043	.2075	.2568	.1010	.0941	.1094	.2361	1896
3-2	10311708745	6.84	.5173	.0951	.0903	.0870	.0921	.1159	.1622	.1555	1490.2217.1814.1962
3-2	10311708746	2.526	.2116	.2147	.2457	.3086	.1223	.1055	.0712	.0711	0517
3-4	11011502711	2.78	.4337	.0751	.0673	.0664	.0634	.0714	.0724	.1065	1063.1173.2183.0848
3-4	11011502712	1.329	.1136	.2056	.0996	.3877	.0994	.4452	.3914	.1399	1866
3-4	11011502713	2.79	.2142	.1732	.1379	.1321	.1264	.0851	.0991	.1058	0987.0695.1061.0807
3-4	11011502714	1.653	.0854	.1595	.1381	.1153	.3631	.3782	.2452	.1095	0941
3-4	11011502715	2.78	.0885	.1844	.1739	.1328	.1505	.1770	.2216	.2439	2348.1466.2499.2083
3-4	11011502716	1.914	.2009	.1052	.0738	.1407	.0786	.1325	.1724	.1139	0420
3-4	11011502717	1.92	.6703	.0229	.0191	.0146	.0113	.0112	.0107	.0119	0180.0299.0651.1490
3-4	11011502718	1.295	.1440	.0461	.1138	.1986	.2998	.2258	.1112	.2319	1436
3-4	11011502721	3.07	.3869	.0847	.0644	.0556	.0634	.0631	.0923	.0765	0651.1054.1572.1640
3-4	11011502722	1.117	.1228	.1242	.1471	.1906	.0785	.4103	.3952	.1584	2700
3-4	11011502723	3.07	.2426	.1602	.1100	.0989	.1048	.0712	.0990	.0916	0898.1011.1323.1274
3-4	11011502724	1.414	.0573	.2314	.2828	.1604	.2267	.1925	.2036	.1275	0834
3-4	11011502725	3.07	.1230	.1274	.1012	.0803	.0963	.0825	.1217	.1660	1604.1054.3260.3690
3-4	11011502726	3.555	.3217	.2093	.0840	.3244	.0536	.0568	.0822	.0685	0262
3-4	11011502731	3.25	.2978	.1344	.1111	.0938	.1001	.0864	.1015	.0984	1008.1351.1777.1437
3-4	11011502732	1.900	.2004	.2293	.0980	.1807	.1927	.0911	.0307	.1253	1938
3-4	11011502733	3.25	.1656	.3388	.2252	.2111	.1654	.1253	.1495	.1159	1216.1185.1287.1550
3-4	11011502734	1.438	.2424	.1689	.2213	.1768	.0490	.0421	.0306	.0481	0786
3-4	11011502735	3.25	.1935	.1428	.1079	.0903	.0921	.0928	.1084	.1231	1802.1345.2727.1630
3-4	11011502736	3.666	.3686	.3290	.1892	.1550	.1111	.0772	.0715	.0548	0434
3-4	11011502741	3.60	.2788	.1596	.1267	.1062	.0965	.0743	.0786	.0833	0920.1167.1394.1260
3-4	11011502742	1.07	.1487	.1416	.2021	.1227	.1825	.1382	.0692	.0665	1374
3-4	11011502743	3.60	.1078	.5038	.3227	.2557	.2055	.1564	.1609	.1047	1207.1431.1033.1417
3-4	11011502744	1.016	.1069	.0857	.0566	.2063	.0388	.0213	.0695	.0638	0168
3-4	11011502745	3.60	.0897	.1596	.1267	.1062	.0965	.0743	.0786	.0832	0920.1167.1394.1260
3-4	11011502746	1.07	.1487	.1416	.2021	.1227	.1825	.1382	.0692	.0665	1374
3-5	11031129711	2.63	.6739	.0447	.0292	.0297	.0300	.0388	.0416	.0595	0936.0902.1235.1920
3-5	11031129712	1.743	.2369	.2076	.1940	.1951	.2626	.1751	.2086	.0699	1831.1329.2726.1623
3-5	11031129713	2.63	.979	.0231	.0213	.0212	.0268	.0601	.0455	.0400	0693.0661.1002.1035
3-5	11031129714	1.532	.0947	.1499	.3063	.2691	.3044	.2019	.1911	.0688	0981.2433.1791.3015
3-5	11031129715	2.63	.7197	.0489	.0436	.0588	.0680	.1058	.1516	.1809	2281.2188.3266.3276
3-5	11031129716	2.964	.3592	.1270	.1266	.1611	.0723	.0792	.0110	.0567	1796.0672.0700.0442
3-5	11031129717	2.751	.461	.0178	.0195	.0154	.0136	.0136	.0201	.0262	0406.0660.1179.1445
3-5	11031129718	2.12	.2728	.2899	.2122	.3635	.5209	.2452	.3076	.1523	3349.2309.5315.2062
3-5	11031129721	2.811	.760	.0388	.0222	.0305	.0430	.0404	.0545	.0640	0863.0712.1274.1260
3-5	11031129722	1.418	.2310	.1600	.1776	.0940	.1431	.0670	.1702	.1139	1800.2132.4046.2792
3-5	11031129723	2.811	.591	.0443	.0369	.0323	.0442	.0495	.0664	.0695	0987.1124.0892.1261

LAKE UNION INTENSIVE MEASUREMENT PROGRAM POWER SPECTRA (continued)

3-5	11031129724	1527.1256.1817.2904.2772.2470.3219.2212.0534.0508.1924.1872.2982
3-5	11031129725	2.811.091.0252.0384.0476.0669.1013.1287.1851.1973.2269.2993.2769
3-5	11031129726	3300.4154.1599.1334.1722.1409.0408.0272.1092.1769.0712.0569.0588
3-5	11031129731	3.832.348.0397.0320.0355.0382.0441.0572.0645.0814.0938.1179.1839
3-5	11031129732	1143.1721.1334.1413.1165.1365.1943.1467.1075.1237.0808.6232.4663
3-5	11031129733	3.831.860.0424.0420.0434.0529.0578.0716.0779.0991.1318.1697.1560
3-5	11031129734	1848.2169.2761.3155.3109.2186.3323.2409.0255.1475.2163.1321.1532
3-5	11031129735	3.831.611.0641.0527.0587.0675.0886.1204.1626.2405.2149.2243.3162
3-5	11031129736	3278.2716.1738.1541.1481.1411.0947.0719.0938.1310.0952.1373.0758
3-5	11031129741	5.063.841.0225.0229.0235.0254.0305.0398.0399.0493.0669.0639.0993
3-5	11031129742	0985.1308.1505.1395.1667.1172.1353.1549.1130.2631.0425.5911.5403
3-5	11031129743	5.061.759.0452.0434.0482.0528.0707.0772.1093.1317.1298.2072.2213
3-5	11031129744	1974.2109.3620.1769.3881.2279.2193.2153.1153.1572.2112.0630.0586
3-5	11031129745	5.06.7930.0594.0563.0474.0425.0778.1049.1095.1385.1580.1883.2901
3-5	11031129746	2509.2377.1597.1966.2115.1910.0770.1376.0511.0994.0675.2613.1985
4-1111151000711	4.731.337.0396.0303.0407.0476.0533.0763.0825.1084.1146.1418.1780	
4-1111151000712	1945.1625.1766.1599.2947.2482.2838.1487.2398.2739.1221.0496.1420	
4-1111151000713	4.73.770.0325.0329.0433.0591.0923.1161.1445.1535.2050.2022.2931	
4-1111151000714	2574.3475.3109.2026.2368.1121.1475.1699.1623.0348.0182.0242.0352	
4-1111151000715	4.73.4781.0649.0597.0791.1186.1475.1998.2152.2246.2545.3371.2637	
4-1111151000716	3079.2610.2087.2401.2420.1048.0999.2319.0309.0557.0401.0079.0092	
4-1111151000717	4.621.250.0262.0245.0052.0062.0099.2184.0323.0590.0750.1331.1899	
4-1111151000718	2220.1970.2419.2467.4098.3616.3999.2570.3567.3271.1955.0753.2467	
4-1111151000721	5.141.445.0338.0307.0317.0404.0531.1671.0923.0890.1043.1274.1605	
4-1111151000722	1791.1888.1812.2315.2528.3714.2481.2046.2146.2201.1376.0358.1290	
4-1111151000723	5.14.2754.0435.0436.0528.0726.1069.1392.1583.1823.2012.2540.2306	
4-1111151000724	1264.1425.2487.2031.2157.1014.1348.1728.1601.0328.0275.0236.0257	
4-1111151000725	5.14.6795.0616.0532.0716.0943.1189.1766.2865.2700.2336.2710.2974	
4-1111151000726	3627.2942.2492.1769.1818.0832.0527.0609.0420.0734.0533.0032.0077	
4-1111151000727	4.721.712.0329.0300.0353.0446.0541.0697.0705.0998.1327.1417.0954	
4-1111151000728	1996.1627.2540.1103.1850.3409.1861.502.0595.2300.2434.0723.1575	
4-1111151000729	7.721.168.0220.0609.0539.0777.1001.4973.1612.1453.2025.2322.1700	
4-1111151000736	2250.2518.2051.2380.1866.1210.1698.1107.2064.0919.0474.0344.0216	
4-1111151000739	6.72.3464.0292.0448.0998.1345.1604.1084.1922.3496.2605.2431.2860	
4-1111151000736	2956.3144.1874.1205.1474.0935.0976.4451.0383.0695.0411.0105.0262	
4-1111151000741	7.721.596.0300.0309.0340.0374.0503.4603.0886.0846.1033.1303.1763	
4-1111151000742	1779.2211.1741.2029.2957.4712.1198.1613.1215.2131.1722.0113.1505	
4-1111151000743	7.72.5680.0419.0331.0401.0560.0817.1030.1121.1603.1957.2424.2213	
4-1111151000744	2691.2297.3140.2687.2868.1494.1336.0935.0961.1119.0536.0361.0669	
4-1111151000745	7.72.5264.0325.0380.0322.0306.0463.0726.0953.0914.0996.1698.1100	
4-1111151000766	1520.1640.1297.0694.1090.0842.0949.0583.0394.0289.0259.0202.0319	
4-1211151130711	4.141.042.0254.0275.0321.0434.0560.0783.0945.0830.1351.1636.1907	
4-1211151130712	2125.1972.1908.2551.2004.2513.1118.2946.2351.1367.0654.0203.0709	
4-1211151130713	4.14.8216.0212.0207.0252.0393.0527.0632.0784.1234.1488.1769.2006	
4-1211151130714	2551.1794.2713.2698.3175.1700.2667.1706.1800.0898.1037.0878.0603	
4-1211151130715	4.14.3401.0467.0593.0740.1175.1267.2021.2868.2483.2860.4196.2888	
4-1211151130716	2320.1984.2153.1038.0802.1311.0480.0414.0400.0243.0057.0159.0250	
4-1211151130717	4.01.9703.0745.0061.0042.0046.0059.0112.0212.0269.0525.0907.1474	
4-1211151130719	1941.2060.2413.2688.3471.2919.1215.3793.3282.1540.0559.0261.0693	

LAKE UNION INTENSIVE MEASUREMENT PROGRAM POWER SPECTRA (continued)

4-1211151130721	4.511.042.0249.0255.0309.0402.0503.0611.0824.0939.1035.1263.1267
4-1211151130722	1.764.1935.1802.1176.2572.2447.1821.3091.1935.1982.1402.0503.0961
4-1211151130723	4.51.8609.0322.0293.0374.0517.0685.0797.1028.1372.1658.1120.2021
4-1211151130724	1.778.1920.3309.3116.2482.2550.2326.1697.1289.0757.0737.0499.0246
4-1211151130725	4.51.4812.0514.0478.0577.0946.1379.1754.2114.2854.2885.3365.3387
4-1211151130726	3.404.1714.1528.1567.1193.1648.0917.0495.0434.0465.0256.0050.0185
4-1211151130731	5.471.358.0276.0248.0274.0282.0416.0612.0647.0727.0908.0927.1108
4-1211151130732	1.747.1316.1606.2242.2065.2046.2177.3795.0981.1439.3327.1799.0792
4-1211151130733	5.47.9730.0514.0353.0450.0568.0688.0895.0977.1564.1736.2009.1966
4-1211151130734	2.053.1714.1946.2111.1690.3921.2338.0607.0081.0361.0290.0236.0124
4-1211151130735	5.47.6640.0666.0574.0588.0886.1271.1468.2415.2684.2958.2576.3244
4-1211151130736	2.689.2299.2379.1626.1584.1429.0796.0539.0468.0466.0337.0108.0124
4-1211151130741	6.091.465.0306.0248.0239.0299.0388.0468.0725.0583.0911.0903.1586
4-1211151130742	1.400.1481.1553.0893.2643.2304.3283.5395.1132.2534.2576.1112.0583
4-1211151130743	6.09.4241.0395.0277.0339.0409.0576.0767.0942.1419.1732.1518.1859
4-1211151130744	2.682.1916.1666.2024.1193.2912.2322.0944.0870.1037.1220.1150.0249
4-1211151130745	6.09.4421.0458.0457.0496.0757.1036.1237.1464.1954.2809.2409.2383
4-1211151130746	2.923.2492.2430.2519.1829.1655.1462.1164.0344.1066.0741.0292.0194
4-12111511315711	2.69.6204.0130.0111.0144.0185.0363.0379.0640.0651.0881.0797.0217
4-12111511315712	1.238.1375.1374.2305.3018.1904.3015.1445.3901.2756.1081.0975.0913
4-12111511315713	2.69.4215.0133.0115.0117.0205.0270.0393.0408.0811.1046.0911.0954
4-12111511315714	1.695.1298.2465.3086.2734.2095.2751.1445.3083.2139.0408.2275.1966
4-12111511315715	2.69.1420.0341.0289.0331.0559.0973.1602.1853.2468.2398.2274.3273
4-12111511315716	3.151.1766.1721.3224.1481.1871.1085.1173.0602.0590.0483.0358.0465
4-12111511315717	2.46.5739.0039.0024.0020.0019.0024.0028.0050.0084.0142.0249.0243
4-12111511315718	0.640.0969.0867.1184.1747.1291.2431.0888.2164.2192.1180.0746.0490
4-12111511315721	2.99.6689.0119.0104.0144.0184.0270.0412.0487.0655.0848.0999.0932
4-12111511315722	1.432.0947.1720.2670.2913.1701.2162.1101.3987.2112.0991.0727.0559
4-12111511315723	2.99.5934.0121.0102.0136.0210.0330.0450.0642.0647.1053.1077.1127
4-12111511315724	2.368.1343.1968.2239.3453.1751.2925.2142.2627.2696.0481.1783.1441
4-12111511315725	2.99.2157.0225.0190.0276.0465.0454.1148.1460.2708.2567.2212.3103
4-12111511315726	3.267.2671.2094.2496.2172.1650.1724.0736.0993.0758.0275.0267.0278
4-12111511315731	3.67.8549.0103.0122.0137.0204.0264.0366.0478.0719.0704.0819.0966
4-12111511315732	0.904.1701.1341.2373.2205.1284.0714.1116.2264.2133.2223.2317.1950
4-12111511315733	3.67.5520.0202.0198.0243.0309.0451.0582.0825.0705.1010.1030.1460
4-12111511315734	1.631.1597.1372.2674.2598.1427.3089.1602.2704.2938.0313.1324.1315
4-12111511315735	3.67.3698.0264.0235.0307.0487.0677.0988.1246.1454.2017.2090.2385
4-12111511315736	3.163.2761.2708.2260.2110.0935.2141.0904.1815.1040.0750.0265.0231
4-12111511315741	3.88.9383.0118.0117.0142.0203.230.0321.0362.0494.0611.0662.1095
4-12111511315742	1.118.1218.1701.2553.1168.1462.1268.2620.1864.4136.4154.1589.1557
4-12111511315743	3.99.2789.0271.0194.0161.0182.0224.0335.0389.0610.0635.0707.1224
4-12111511315744	1.710.1807.1800.2410.1583.0468.3034.0972.5103.2890.1023.1127.0971
4-12111511315745	3.98.2200.0319.0257.0272.0359.0504.0713.1038.1457.1660.2127.2760
4-12111511315746	2.003.2893.1847.3067.2773.2340.1058.0767.1600.1458.1621.0566.0450
5-1111201038711	3.601.161.0271.0258.0266.0308.0461.0525.0688.0917.1212.0092.1766
5-1111201038712	1.221.1669.2734.2970.1700.2023.2688.1760.1867.1608.1680.1720.0687
5-1111201038713	3.59.6440.0535.0260.0341.0436.0638.0699.1077.1068.1126.1496.1562
5-1111201038714	2.696.2819.5233.2298.1343.2548.1895.2554.1230.0667.0298.0227.0195
5-1111201038715	3.69.2763.0890.0742.0860.1226.1835.2237.2447.3132.3258.2947.4077

LAKE UNION INTENSIVE MEASUREMENT PROGRAM POWER SPECTRA (continued)

5-1111201038715 .2239, .2420, .1553, .1380, .0914, .1023, .0367, .0560, .0542, .0138, .0210, .0168, .0043  
5-1111201038717 3.861, .167, .0047, .0044, .0039, .0044, .0076, .0116, .0205, .0317, .0624, .0697, .1698  
5-1111201038718 .1335, .1732, .3093, .3995, .2211, .2741, .5148, .2702, .2585, .2317, .2653, .2338, .0901  
5-1111201038721 4.141, .264, .0199, .0229, .0259, .0343, .0395, .0561, .0689, .0747, .1048, .0980, .1377  
5-1111201038722 .1202, .1462, .1449, .2284, .1773, .1903, .3273, .1820, .1853, .0720, .2486, .2749, .1199  
5-1111201038723 4.14, .8323, .0302, .0350, .0372, .0507, .0645, .0720, .0852, .1188, .1360, .1745, .2000  
5-1111201038724 .2499, .2018, .3989, .1660, .1433, .3558, .1879, .2453, .1404, .0923, .0596, .0229, .0069  
5-1111201038725 4.14, .4862, .0692, .0543, .0590, .1136, .1483, .1858, .2259, .3160, .2758, .3522, .3229  
5-1111201038726 .3675, .2687, .1016, .1178, .0687, .1478, .0254, .0546, .0899, .0118, .0529, .0380, .0021  
5-1111201038731 5.211, .895, .0209, .0169, .0191, .0268, .0303, .0397, .0510, .0545, .0636, .1156, .1476  
5-1111201038732 .1888, .1555, .1924, .1680, .1931, .1893, .3375, .2367, .2575, .0608, .1935, .2938, .1400  
5-1111201038733 5.211, .035, .0558, .0410, .0414, .0471, .0619, .0648, .0772, .0946, .1373, .1691, .2161  
5-1111201038734 .2277, .1788, .3211, .2293, .2594, .3790, .1243, .1389, .2675, .1086, .0713, .0494, .0232  
5-1111201038735 5.21, .6202, .0668, .0685, .0862, .1108, .1403, .1612, .1546, .1987, .2366, .3286, .2943  
5-1111201038736 .3555, .2791, .2745, .1202, .1145, .1100, .0760, .0511, .0589, .0504, .0853, .0549, .0066  
5-1111201038741 6.201, .541, .0286, .0237, .0283, .0338, .0415, .0489, .0557, .0812, .1457, .1220, .1513  
5-1111201038742 .1617, .1142, .1750, .2478, .3092, .1892, .4007, .2015, .1215, .2117, .1540, .1143, .0280  
5-1111201038743 6.00, .5440, .0359, .0384, .0353, .0445, .0495, .0747, .0800, .0861, .1012, .1573, .2370  
5-1111201038744 .2034, .1691, .3322, .2778, .2087, .1906, .2291, .2014, .3280, .1125, .0873, .0468, .0356  
5-1111201038745 6.00, .4913, .0614, .0670, .0505, .0716, .0892, .1220, .1511, .1825, .1911, .2424, .3664  
5-1111201038746 .3001, .3379, .1970, .2460, .1817, .1736, .1513, .0731, .0694, .0776, .0126, .0384, .0298  
5-2111211134711 2.67, .5055, .0391, .0254, .0277, .0353, .0423, .0629, .0705, .0834, .0972, .1282, .1760  
5-2111211134712 .1435, .1403, .1743, .4051, .1100, .2134, .2342, .1796, .2853, .4039, .2559, .1287, .0859  
5-2111211134713 2.67, .4267, .0619, .0416, .0419, .0454, .0553, .0684, .0786, .1054, .1368, .1656, .2056  
5-2111211134714 .1829, .2338, .2812, .2478, .1812, .2284, .0912, .2236, .1725, .2382, .1279, .0285, .0900  
5-2111211134715 2.67, .1303, .1044, .0635, .0569, .0799, .1073, .1376, .1901, .1859, .2212, .2459, .2312  
5-2111211134716 .1921, .3154, .2604, .2717, .1739, .1649, .1380, .1021, .1024, .0913, .0301, .0374, .0303  
5-2111211134717 2.65, .5325, .0060, .0030, .0026, .0024, .0021, .0043, .0056, .0120, .0172, .0354, .0679  
5-2111211134718 .0681, .0715, .0974, .2295, .0693, .1211, .1463, .1360, .1984, .2920, .1909, .0952, .0558  
5-2111211134721 3.12, .5262, .0284, .0211, .0243, .0293, .0333, .0485, .0744, .0704, .0846, .1165, .0960  
5-2111211134722 .3201, .2014, .1497, .4207, .1300, .1959, .2493, .2022, .3586, .3068, .1930, .1577, .1220  
5-2111211134723 3.12, .4845, .0305, .0239, .0266, .0369, .0659, .0618, .0805, .1064, .1267, .1895, .1345  
5-2111211134724 .2333, .2628, .3271, .2598, .2315, .2282, .0529, .1649, .2254, .2239, .1172, .0572, .0903  
5-2111211134725 3.12, .2137, .0467, .0365, .0398, .0522, .0903, .1187, .1620, .1928, .2398, .2577, .2400  
5-2111211134726 .1912, .2451, .3111, .3080, .1585, .1959, .1652, .1144, .0747, .0825, .0655, .0644, .0359  
5-2111211134731 3.60, .5096, .0423, .0283, .0266, .0291, .0330, .0419, .0550, .0676, .0736, .0850, .1195  
5-2111211134732 .1566, .1618, .2345, .2046, .2242, .1079, .1281, .1509, .4601, .4046, .3150, .2341, .1895  
5-2111211134733 3.60, .6075, .0450, .0360, .0343, .0428, .0518, .0629, .0744, .0610, .0913, .0996, .1243  
5-2111211134734 .1824, .2375, .3280, .1815, .2546, .1427, .1053, .2250, .2141, .2537, .1087, .0375, .0583  
5-2111211134735 3.60, .2517, .0251, .0460, .0520, .0544, .0778, .1045, .1583, .1861, .1776, .2588, .1030  
5-2111211134736 .2922, .2212, .2816, .2499, .1680, .1628, .2771, .1866, .1194, .0509, .0294, .0507, .0528  
5-2111211134741 3.25, .3288, .0476, .0399, .0315, .3392, .0491, .0575, .0324, .0769, .0914, .1245, .1509  
5-2111211134742 .1025, .1297, .1485, .1699, .1869, .1350, .1331, .2149, .3894, .5297, .3780, .1304, .1109  
5-2111211134743 3.25, .2807, .0699, .0619, .0304, .0337, .0333, .0358, .0607, .0542, .0451, .0750, .0740  
5-2111211134744 .1331, .1665, .2576, .1697, .1359, .1615, .0996, .2971, .3126, .3042, .1009, .1012, .1516  
5-2111211134745 3.25, .1245, .1044, .0619, .0579, .0546, .0698, .0907, .1057, .1270, .1726, .1789, .1551  
5-2111211134746 .2374, .2234, .2445, .1799, .3439, .1730, .1677, .2429, .1767, .1053, .1051, .1158, .0880  
6-1111281310711 4.071, .604, .0355, .0330, .0334, .0391, .0462, .0562, .0663, .0904, .0867, .1032, .1059  
6-1111281310712 .1221, .1634, .1395, .2126, .0841, .2564, .2301, .1658, .2843, .1645, .2646, .3119, .2688

LAKE UNION INTENSIVE MEASUREMENT PROGRAM POWER SPECTRA (continued)

6-1111281310713 4.071,308,0462,0397,0400,0480,0527,0646,0861,1002,1132,1709,0942  
6-1111281310714 4.441,1665,2899,2853,1812,0903,0977,5275,5089,0964,1135,0814,0365  
6-1111281310715 4.07,2990,1206,1104,1284,1481,2301,2782,2492,3300,2722,2354,2350  
6-1111281310716 1864,1669,2507,1297,0949,1143,0821,1108,0529,0563,0209,0419,0294  
6-1111281310717 4.471,850,0231,0160,0142,0137,0161,0238,0383,0681,0816,1360,1541  
6-1111281310718 1947,3312,2595,4635,1636,6128,5444,4225,4899,3049,5480,6363,5653  
6-1111281310721 4.571,506,0469,0340,0338,0429,0540,0537,0583,0914,0897,1286,0993  
6-1111281310722 1241,1659,1357,1745,0749,2164,2140,1818,2845,1605,2553,2956,2733  
6-1111281310723 4.571,444,0552,0459,0433,0563,0618,0732,1082,1191,1000,1731,1247  
6-1111281310724 1513,1977,1941,2125,2034,1622,1051,5313,4336,0602,1308,0948,0293  
6-1111281310725 4.57,5932,0778,0665,0774,1212,1691,1869,2438,3167,2109,2693,2493  
6-1111281310726 2309,1806,2397,1599,1178,1412,1372,1109,0462,0590,0323,0670,0537  
6-1111281310731 5.572,031,0366,0337,0344,0399,0415,0415,0526,0719,1001,1016,0958  
6-1111281310732 1204,1341,1393,1440,0839,2489,1750,1856,3280,1421,1197,1963,3251  
6-1111281310733 5.571,400,0538,0562,0539,0657,0616,0775,1014,1088,1026,1323,1099  
6-1111281310734 1757,2615,1974,2723,2536,1457,0547,3846,4137,1573,0875,0880,0567  
6-1111281310735 5.57,8889,1081,0827,1062,1160,1638,1583,2609,2519,2788,2336,2368  
6-1111281310736 2416,1867,2167,1819,1080,2277,0954,0320,0882,0528,0680,0488,0342  
6-1111281310741 5.301,987,0428,0383,0329,0386,0465,0538,0584,0756,0791,1238,1174  
6-1111281310742 1245,2216,1511,1266,1103,1585,1103,2767,4624,2567,0634,1405,2416  
6-1111281310743 6.30,982,0694,0541,0499,0622,0704,0756,0897,0847,1179,1296,1588  
6-1111281310744 1353,1805,1790,1822,1315,1693,0828,1800,2176,2479,2463,2051,1472  
6-1111281310745 6.30,2425,0643,0559,0634,0708,0948,1266,1296,1703,1996,2954,1763  
6-1111281310746 2239,4004,3283,2226,2206,1774,1660,0637,0880,0720,0459,0287,0250  
6-1211281450711 4.691,517,0466,0436,0472,0563,0736,0747,0771,1057,1270,1412,1824  
6-1211281450712 1867,2572,3287,2543,2237,2791,1652,0646,1185,1334,1416,0746,1176  
6-1211281450713 4.691,070,0549,0501,0513,0612,0713,1015,0988,1255,1482,2360,1988  
6-1211281450714 1971,3396,3117,2614,2035,0499,2949,0539,1950,1140,1081,1379,0793  
6-1211281450715 4.69,3534,1316,1150,1301,1859,2190,3334,3129,2830,2903,3147,2912  
6-1211281450716 2284,3599,1527,1176,0929,0591,0623,0328,0138,0216,0740,0154,0890  
6-1211281450717 5.181,557,0195,0170,0149,0171,0221,0286,0491,0787,1122,1430,2511  
6-1211281450718 2783,4796,6736,5198,4585,5650,3167,0944,2597,2164,1960,1267,2308  
6-1211281450721 5.421,630,0677,0696,0533,0531,0718,0652,0898,1010,1137,1892,1450  
6-1211281450722 2056,2462,3209,3147,2021,2080,2197,0585,1317,1190,1139,0594,0915  
6-1211281450723 5.421,377,0893,0563,0619,0823,0886,1248,1419,1582,1659,1801,2441  
6-1211281450724 2185,3102,3751,2720,1946,0855,1875,1387,1462,0687,0706,0851,0509  
6-1211281450725 5.42,2671,1036,0878,0997,1444,1719,1838,2620,3511,3224,2463,2459  
6-1211281450726 2640,2253,1720,2014,1501,0511,0657,0107,0384,0224,0331,0249,0126  
6-1211281450727 6.012,329,0631,0358,0401,0415,0497,0502,0630,0930,1099,1011,1640  
6-1211281450728 1078,1880,2087,2819,2421,2793,2022,0777,1134,1656,3664,1640,1157  
6-1211281450729 6.211,093,1165,0827,0812,0789,1101,1087,1635,1556,1827,1770,2587  
6-1211281450734 2281,2536,3238,2613,2185,2448,1405,0764,0622,1300,0932,0508,0264  
6-1211281450735 6.21,5242,1729,1110,1107,1592,1985,1921,2175,2456,2732,2712,2010  
6-1211281450736 3420,1569,1748,1705,1794,1604,1644,0334,0519,0191,0045,0043,0236  
6-1211281450741 7.862,019,0465,0634,0469,0442,0452,0716,0848,0818,1216,1007,1596  
6-1211281450742 1601,2091,1961,3206,1847,2305,3527,1521,1140,0959,3015,1787,1400  
6-1211281450743 7.86,4668,0972,0908,0840,0941,0849,1024,1290,1260,1479,1393,1844  
6-1211281450744 1739,2390,3142,4089,2594,2399,1648,1020,0490,1086,1428,0185,0247  
6-1211281450745 7.86,9780,0959,0739,0851,0991,1468,1517,1947,1974,2859,3233,2539

LAKE UNION INTENSIVE MEASUREMENT PROGRAM POWER SPECTRA (continued)

6-1211281450746, 3422, 2198, 2337, 1508, 1179, 1611, 0812, 0744, 0377, 0270, 0174, 0298, 0751  
7-1111261900711 2.91, 5176, 0421, 0376, 0355, 0369, 0379, 0661, 0639, 1030, 0956, 1314, 1580  
7-1111261900712, 1925, 1828, 2133, 2371, 4150, 2907, 1424, 2314, 1399, 0975, 0810, 1859, 1270  
7-1111261900713 2.91, 2210, 2581, 1705, 1381, 1240, 1104, 1120, 1202, 1351, 1665, 1660, 1494  
7-1111261900714, 1879, 1973, 2642, 3077, 1991, 2722, 1901, 1315, 0702, 0646, 0651, 0619, 0388  
7-1111261900715 2.91, 1292, 1273, 1137, 1071, 1136, 1464, 1514, 2135, 2366, 2554, 3003, 2623  
7-1111261900716, 3051, 3334, 1652, 1299, 1215, 1207, 0829, 1173, 0829, 0149, 0426, 0293, 0229  
7-1111261900717 2.62, 5126, 0237, 0134, 0100, 0069, 0061, 0068, 0080, 0122, 0167, 0306, 0700  
7-1111261900718, 0810, 0905, 1196, 1541, 2590, 1878, 0883, 1288, 0707, 0800, 0431, 1113, 0810  
7-1111261900721 3.31, 5942, 0412, 0339, 0316, 0401, 0439, 0529, 0667, 0675, 0873, 0940, 1367  
7-1111261900722, 1740, 1374, 1853, 2417, 3605, 4394, 2237, 2451, 1234, 0683, 1174, 1814, 1387  
7-1111261900723 3.31, 2877, 1703, 1229, 0985, 0991, 1091, 1187, 1454, 1457, 1687, 1646, 2275  
7-1111261900724, 2299, 2774, 1716, 3224, 2441, 2449, 1148, 0955, 0962, 0851, 0635, 0383, 0065  
7-1111261900725 3.31, 2162, 0774, 0609, 0544, 0744, 0849, 1218, 2009, 2741, 2741, 3051, 3162  
7-1111261900726, 3105, 3282, 2660, 1831, 1363, 0996, 0826, 1268, 0835, 0337, 1025, 0631, 0093  
7-1111261900731 4.06, 6348, 0610, 0445, 0389, 0442, 0522, 0524, 0699, 0795, 0608, 0797, 1413  
7-1111261900732, 1126, 1544, 1307, 3294, 2123, 3056, 2762, 2499, 2362, 1344, 1734, 1947, 1973  
7-1111261900733 4.06, 4242, 1368, 1286, 1024, 1017, 0905, 1204, 1200, 1377, 1964, 1751, 1878  
7-1111261900734, 2088, 2603, 1688, 3385, 2577, 2267, 1202, 0431, 1482, 1662, 0968, 0148, 0195  
7-1111261900735 4.06, 2871, 1041, 0884, 0916, 0995, 0948, 1592, 1840, 2272, 2504, 3410, 3524  
7-1111261900736, 2202, 2257, 3034, 2469, 1928, 1492, 0674, 0871, 0803, 0196, 0274, 0134, 0042  
7-1111261900741 4.47, 7126, 0559, 0425, 0394, 0427, 0478, 0497, 0575, 0623, 0943, 1085, 1249  
7-1111261900742, 1147, 1336, 1774, 1580, 2034, 2892, 4485, 2995, 1224, 1391, 0553, 2845, 2154  
7-1111261900743 4.47, 3106, 2195, 1500, 1308, 1085, 0927, 0935, 1039, 1190, 1261, 1358, 1466  
7-1111261900744, 2452, 2186, 1818, 2872, 2685, 3205, 2662, 1582, 0353, 1322, 1233, 0613, 0466  
7-1111261900745 4.47, 1218, 2673, 2054, 1552, 1398, 1393, 1613, 1691, 1533, 1567, 1919, 2012  
7-1111261900746, 1843, 2124, 1564, 3130, 2164, 2136, 2005, 1138, 0631, 0508, 0658, 0211, 0240  
7-2111270909711 4.53, 617, 0291, 0298, 0309, 0377, 0489, 0676, 0533, 0840, 0786, 1252, 1506  
7-2111270909712, 1728, 1585, 2088, 1741, 1227, 1909, 2057, 1501, 1238, 1518, 1347, 1371, 1009  
7-2111270909713 4.53, 4326, 0273, 0851, 0816, 0916, 1076, 1367, 1264, 1795, 1846, 2146, 1936  
7-2111270909714, 2328, 1065, 1646, 2548, 1887, 1714, 1674, 1706, 0805, 0596, 0749, 0624, 0196  
7-2111270909715 4.53, 3902, 1243, 0913, 0990, 1269, 1891, 2324, 1248, 2906, 3448, 3356, 3458  
7-2111270909716, 3348, 1851, 1527, 1015, 0544, 0802, 0251, 0196, 0380, 0304, 0017, 0150, 0328  
7-2111270909717 4.46, 1524, 0233, 0151, 0154, 0129, 0165, 0237, 0154, 0494, 0660, 1672, 1663  
7-2111270909718, 2551, 2562, 3299, 2330, 1767, 3527, 3558, 2694, 2463, 3050, 2498, 2573, 1867  
7-2111270909721 5.22, 921, 0140, 0287, 0286, 0376, 0456, 0463, 0609, 0706, 0757, 1053, 1476  
7-2111270909722, 1543, 1113, 2243, 1905, 0929, 2457, 1822, 0811, 1811, 1821, 1322, 1284, 0209  
7-2111270909723 5.22, 8200, 0854, 0818, 0882, 0015, 1027, 1683, 1683, 1606, 2360, 1823, 3005  
7-2111270909724, 2074, 1368, 2028, 2224, 2478, 1400, 1231, 1060, 0596, 0728, 0101, 0406, 0257  
7-2111270909725 5.22, 4908, 0914, 0678, 0909, 1304, 1590, 1871, 2572, 2041, 2961, 3373, 2520  
7-2111270909726, 2823, 2711, 2145, 1348, 0685, 0950, 0637, 0188, 0421, 0630, 0142, 0216, 0390  
7-2111270909731 4.54, 828, 0447, 0416, 0417, 0463, 0580, 0726, 0507, 0765, 0835, 1204, 1023  
7-2111270909732, 1388, 1417, 2363, 2264, 2908, 2342, 2113, 1158, 1763, 0731, 0888, 1035, 0700  
7-2111270909733 6.28, 163, 0370, 0825, 0765, 0947, 1146, 1105, 1584, 1781, 1971, 1681, 2063  
7-2111270909734, 2812, 2812, 1487, 1760, 3702, 1842, 1822, 0880, 0149, 0784, 0442, 0975, 0247  
7-2111270909735 6.28, 7887, 0867, 1045, 1214, 1687, 2180, 2053, 2858, 2326, 2647, 2974, 2804  
7-2111270909736, 2136, 2180, 2078, 1701, 0490, 0880, 0893, 0341, 0287, 0318, 0291, 0111, 0280  
7-2111270909741 7.11, 705, 0549, 0516, 0394, 0475, 0454, 0638, 0720, 0782, 1229, 1125, 1155  
7-2111270909742, 1684, 1781, 2284, 2377, 1109, 3717, 3725, 1419, 1149, 1511, 2216, 1333, 0520

LAKE UNION INTENSIVE MEASUREMENT PROGRAM POWER SPECTRA (continued)

7-2111270709743	7.17.8667.0909.0824.0764.0728.0961.1194.1278.1511.1633.2213.1454
7-2111270709744	2568.2025.1911.1891.2153.2618.2318.1367.0644.0252.0277.0394.0196
7-2111270909745	7.17.5801.1003.0794.0745.1000.1129.1443.1846.1903.2190.2631.3706
7-2111270909746	3090.2075.2955.2732.1548.0909.1002.0670.0723.0465.0629.0273.0126
7-3111271604711	6.343.123.0365.0409.0437.0486.0695.0838.0897.1068.1204.1561.1958
7-3111271604712	1320.2557.2019.1081.1672.1406.1554.2543.1784.1639.1550.1798.2128
7-3111271604713	6.341.715.0781.0480.0549.0758.1006.1158.1223.1723.2035.2623.1950
7-3111271604714	2197.2141.1652.2449.1477.3284.1468.1838.1189.0179.0621.0748.0970
7-3111271604715	6.34.7284.1310.1316.1341.1864.2131.3006.2811.3685.2609.2600.3003
7-3111271604716	2233.1654.1837.1003.1021.0524.0391.0444.0185.0082.0126.0148.0102
7-3111271604717	6.52.3.11.0235.0222.0224.0299.0586.0772.1107.1765.2926.4302.5603
7-3111271604718	3545.7606.7237.3560.5374.5214.6748.004.6513.6434.6080.7332.7933
7-3111271604721	7.35.3.55.0566.0389.0387.0445.0541.0639.0854.0777.0920.1062.1358
7-3111271604722	1772.2821.2341.0842.1682.1692.1521.2332.2030.1688.1692.1898.2200
7-3111271604723	7.35.2.05.0862.0523.0735.0782.0986.1326.1770.1689.2398.2386.1537
7-3111271604724	2321.2394.1188.2119.2060.2999.1604.1683.0967.0252.0393.0755.0945
7-3111271604725	7.351.160.1505.1118.1228.1541.2178.2862.2696.4112.3041.2644.2300
7-3111271604726	1996.2029.2039.1159.0987.0725.0465.0257.0156.0127.0095.0052.0075
7-3111271604731	8.734.055.0465.0388.0407.0437.0591.0840.0823.1172.1019.1294.1136
7-3111271604732	1502.1841.2733.0298.2032.2138.1917.1716.2037.0951.1251.2371.2602
7-3111271604733	8.731.882.1514.0876.0816.0888.1030.1279.1496.1796.2039.2468.1528
7-3111271604734	3179.2750.2522.1655.1557.2456.1558.0589.0457.0521.0426.0724.0521
7-3111271604735	8.731.395.1585.1326.1366.1776.2135.2903.3413.3190.2765.2419.2734
7-3111271604736	1823.1900.1878.1352.1039.0901.0364.0266.0165.0108.0416.0378.0078
7-3111271604741	153.890.0381.0375.0617.0647.0562.0708.0778.0748.0890.0858.1628
7-3111271604742	1512.1361.1277.1896.2532.2777.0934.1218.2200.0442.1797.3990.2780
7-3111271604743	151.195.1037.0670.0758.0934.0934.1053.1264.1593.1927.3260.1440
7-3111271604744	3112.1895.2321.2205.1511.2085.2196.0502.0528.0545.0568.0471.0455
7-3111271604745	151.548.0864.0745.0907.1050.1362.1824.2394.2466.2954.2973.2944
7-3111271604746	2453.2331.1824.1896.1740.1553.1330.0548.0617.0140.0126.0398.0366
8-1112061430711	2.74.5841.0443.0177.0409.0657.0588.0730.0821.1274.1390.1714.2174
8-1112061430712	2190.1983.2172.2665.3512.1729.1487.1166.1378.1967.1565.0643.0633
8-1112061430713	2.74.4647.0687.0623.0386.0640.0523.0647.0776.1235.1138.1628.1796
8-1112061430714	1505.2157.1888.2496.2297.1907.0924.2196.0915.2179.2594.1187.0336
8-1112061430715	2.74.2341.0650.0610.0687.0889.1104.1087.1740.2469.3027.3028.3312
8-1112061430716	2202.1978.2002.2000.2153.0854.0986.0552.0792.0605.0577.0292.0201
8-1112061430717	405.4291.0146.0132.0112.0083.0087.0091.0105.0152.0257.0463.0660
8-1112061430718	1063.1125.1457.2445.2920.1535.1077.1025.0979.1847.1215.0794.0374
8-1112061430721	4.22.8002.0648.0371.0331.0388.0402.0660.0860.1101.1220.1518.1259
8-1112061430722	1630.2284.2133.3187.3410.2028.2825.2051.1775.1656.0873.0387.0360
8-1112061430723	3.22.0615.0487.0481.0475.0464.0761.0907.1409.1511.1321.1696.2100
8-1112061430724	1673.2256.2022.2972.2208.2116.0667.1676.1197.1731.1022.0330.0695
8-1112061430729	3.22.4934.0379.0347.0391.0396.0739.1064.1734.2124.2869.2584.3068
8-1112061430726	2379.2342.1945.1636.2491.1552.1429.1180.0922.0911.0642.0276.0111
8-1112061430731	4.171.929.0866.0398.0445.0451.0520.0583.0812.0853.1144.1674.1276
8-1112061430732	1457.1628.2467.2179.4100.1955.2267.1492.1940.1501.0773.0359.0696
8-1112061430733	4.170.928.0620.0508.0552.0617.0892.0832.1180.1491.1368.1412.2074
8-1112061430734	1741.2067.3907.3361.1436.2172.0691.1020.1767.1371.1556.0561.0277
8-1112061430735	4.17.5714.0707.0592.0582.0719.0979.1227.1676.2080.1976.2185.1898

LAKE UNION INTENSIVE MEASUREMENT PROGRAM POWER SPECTRA (continued)

R-1112061430736	2374	3027	3207	2461	2416	1200	0814	1259	0848	0635	0305	0145	0170	
R-1112061430741	5	321	170	0529	0388	0385	0417	0546	0653	0674	0901	1082	1317	1140
R-1112061430742	1506	1599	2200	3345	3591	0869	1563	3049	2104	1691	1343	0905	0757	
R-1112061430743	5	32	6317	0808	0723	0717	0775	0724	0949	1143	1374	1441	1775	1564
R-1112061430744	2177	2967	3253	2474	1121	1629	1887	1383	1078	1129	0559	1102	0891	
R-1112061430745	5	32	3294	1121	0733	0898	0905	1096	1478	1505	1967	1933	2750	2588
R-1112061430746	3500	2214	2615	1940	1345	1493	1274	0912	1130	0625	0382	0297	0275	
R-2112111240711	4	701	972	0287	0294	0347	0365	0485	0555	0753	0766	0927	0890	1201
R-2112111240712	1687	1835	1895	2045	2071	2191	2849	1920	3143	2410	1194	1049	0805	
R-2112111240713	4	701	192	0758	0490	0467	0534	0638	0629	1113	1064	1800	2104	1895
R-2112111240714	2670	2410	1992	3166	1151	1931	1989	1200	1491	3178	2293	0592	0530	
R-2112111240715	4	70	4638	1056	1009	1115	1519	1808	2591	2679	2875	2659	3056	2721
R-2112111240716	2046	1751	2917	0885	0796	0903	0255	0479	0838	0457	0272	0189	0071	
R-2112111240717	7082	005	0272	0146	0127	0121	0167	0300	0404	0752	0959	2112		
R-2112111240718	3186	3830	3633	4957	3474	4910	7052	5092	7911	6402	2730	2447	1794	
R-2112111240721	3	032	191	0286	0261	0305	0372	0454	0584	0617	0729	0936	1007	1143
R-2112111240722	1287	1994	1975	1468	1959	2834	3378	1838	3520	2953	1401	1454	0553	
R-2112111240723	5	031	532	0587	0507	0583	0536	0765	1090	1180	1177	1493	1490	2395
R-2112111240724	1765	2645	1919	2251	1302	2106	1647	1344	1814	2592	2296	0808	0554	
R-2112111240725	5	03	6951	0772	0722	0926	1166	1743	2150	2503	3255	3074	2663	3290
R-2112111240726	2350	1919	2642	1219	1500	0719	0431	0393	0788	0431	0280	0173	0012	
R-2112111240727	6	482	954	0392	0295	0299	0318	0436	0532	0641	0629	1088	1070	0821
R-2112111240728	0798	1388	1668	0285	1623	2730	4142	2408	3547	3838	0663	0834	0595	
R-2112111240729	6	481	830	0690	0580	0619	0708	0800	1030	1048	1646	1546	1786	2749
R-2112111240734	1705	1843	2342	2118	1249	1525	1515	1410	2025	2906	1644	0486	0307	
R-2112111240735	6	481	057	0773	0919	1010	1258	1668	1777	2478	2480	2987	2944	2295
R-2112111240736	2043	2455	1630	1931	1798	1106	0810	0439	0518	0507	0433	0235	0026	
R-2112111240741	7	373	477	0314	0246	0241	0265	0315	0280	0352	0476	0503	0817	0785
R-2112111240742	1072	1077	1035	1909	0953	2785	4133	2158	3231	3346	0365	0421	0483	
R-2112111240743	7	37	6496	1932	0997	0758	0908	0831	1024	1273	1463	1469	1674	2257
R-2112111240744	2553	2108	1946	2146	0850	1607	0720	1017	2659	3206	1554	0237	0188	
R-2112111240745	7	37	8360	0799	0512	0684	0801	1072	1568	1305	1907	1778	2818	2560
R-2112111240746	1086	2768	2267	2050	1821	2067	0751	0706	1091	0922	0645	0366	0062	
R22512111536711	4	731	761	0577	0373	0433	0469	0462	0854	0967	1094	1084	1424	1210
R22512111536712	1407	2102	2720	2683	3020	2052	1047	2683	2696	1052	2770	1135	0191	
R22512111536713	6	330	640	0888	0776	0886	0673	0927	0981	1117	1061	1581	1278	2142
R22512111536714	1047	6221	2308	2925	1789	1051	0802	2086	2138	0933	1351	1053	0513	
R22512111536715	4	730	309	1240	0940	1099	1686	2164	2827	1701	3303	3005	2683	2592
R22512111536716	2854	1460	1816	1414	0676	0751	0624	0394	0270	0152	0129	0123	0082	
R22512111536717	4	851	293	0162	0142	0121	0125	0159	0278	0346	0472	0760	1371	1509
R22512111536718	2157	3300	4096	4041	4253	4342	1464	3631	4032	2860	3861	1709	0732	
R22512111536721	5	011	368	0621	0410	0430	0605	0703	0689	1083	1129	1257	1347	1366
R22512111536722	2033	2129	3169	2669	2990	2838	1272	2177	2521	1486	2140	0947	0590	
R22512111536723	5	011	116	0625	0579	0610	0750	1016	1008	1344	1576	2479	2367	2133
R22512111536724	1882	5	72	2716	2787	1176	1018	1326	1792	1277	0561	0763	0424	0258
R22512111536725	9	030	699	0732	0688	0847	1101	1356	1994	2385	3475	3945	2642	2782
R22512111536726	2416	2908	2000	2141	1444	1420	0377	0295	0250	0016	0049	0174	0160	
R22512111536731	6	271	722	0584	0677	0467	0433	0585	0648	0906	1217	1163	1402	1402
R22512111536732	2046	2733	3755	2521	1533	3076	1560	1126	1740	2023	1664	0602	0580	

LAKE UNION INTENSIVE MEASUREMENT PROGRAM POWER SPECTRA (continued)

822512111536733 6.221.118.0871.0812.0844.0965.0955.1547.1586.2100.2471.2127.2332  
822512111536734 7.042.3652.3581.1163.1253.2100.1548.1152.0831.0573.0249.0112.0030  
822512111536735 6.221.013.0781.0716.0848.1153.1588.1754.2124.2963.2446.2788.2605  
822512111536736 7.895.2200.2008.2592.2098.1340.0799.0222.0324.0220.0240.0243.0206  
822512111536741 7.092.285.0480.0347.0350.0443.0504.0554.0610.0767.1030.1356.1387  
822512111536742 1.553.1542.2317.2204.2988.2287.1625.2003.2294.2071.2486.0712.0789  
822512111536743 7.090.635.1208.0872.0790.0838.1047.1149.1335.1818.1944.2132.2572  
822512111536744 2.356.3138.2430.1502.1723.3103.2145.1394.0354.0523.0396.0111.0210  
822512111536745 7.09.6085.0591.0427.0499.0526.0693.0746.0963.1217.1421.1525.1454  
822512111536746 1.639.2296.0936.1102.1048.0806.0834.0336.0779.0273.0459.0252.0113  
822512111746711 6.745.043.0450.0384.0374.0454.0540.0643.0610.0758.1079.0933.1378  
822512111746712 1.487.1782.2420.1965.1873.1200.4706.1211.0703.1198.1304.1397.0607  
822512111746713 6.742.360.0784.0592.0587.0699.0786.1082.1233.1166.1670.1730.2743  
822512111746714 2.329.2125.2777.1402.1680.2193.1261.0942.1193.2339.0826.0362.0448  
822512111746715 6.74.9550.2065.1676.1934.1985.2424.2777.3027.3201.2964.2393.2289  
822512111746716 1.820.1950.1323.1313.0727.0702.0645.0205.0196.0130.0211.0129.0034  
822512111746717 1.975.316.0546.0284.0296.0398.0700.1069.1487.2567.4115.3773.7718  
822512111746718 7.007.88671.2681.0861.089.86822.748.7689.4379.9309.9008.8644.3651  
822512111746721 7.756.132.0411.0335.0335.0403.0441.0628.0757.0797.1047.0949.1194  
822512111746722 1.415.1822.1800.2641.2190.1219.4822.1260.0866.1760.1597.1393.0692  
822512111746723 7.753.408.0965.0724.0711.0860.0946.1371.1583.1581.1473.2514.2221  
822512111746724 2.231.1891.3240.1475.1676.2054.1238.0664.1231.2190.1120.0529.0308  
822512111746725 7.751.683.1355.1237.1427.1478.1895.3979.2687.3221.3047.2363.1996  
822512111746726 2.251.3072.1318.2004.1067.0534.0762.0286.0271.0718.0202.0064.0064  
822512111746729 9.177.177.0418.0176.0192.0406.0492.0579.0482.0877.0576.1133.0904  
822512111746732 1.543.1801.2414.2719.3018.1523.5886.1307.0943.1343.1301.1112.0689  
822512111746733 9.373.148.0220.0237.0739.0827.0944.1185.1211.1726.1840.1926.2046  
822512111746736 2.879.2734.1122.1604.1960.1750.1081.0768.0891.2494.1444.0417.0177  
822512111746739 9.172.617.1362.1403.1393.1795.2014.2229.2295.3059.2277.2474.2474  
822512111746736 3.163.2755.1367.1236.0580.0762.1475.0402.0217.0201.0107.0031.0035  
822512111746741 0.67.733.0422.0365.0374.0464.0664.0628.0417.0435.0904.1982.1366  
822512111746742 1.714.1072.1407.1742.1546.1521.4378.1974.1922.2462.1704.0462.0903  
822512111746743 0.61.791.0788.0787.0672.0705.0953.1294.1240.1306.1574.1470.2346  
822512111746744 3.051.2856.1647.1700.2031.1893.0932.1660.1430.1077.1755.1104.0170  
822512111746745 1.041.814.1032.0914.1047.1252.1685.1500.1794.2166.2066.2064.2443  
822512111746746 2.761.3394.1877.1904.0908.1328.2688.0625.0536.0289.0142.0108.0008  
822512111930711 7.376.410.0640.0511.0660.0533.0720.0739.0907.1062.1601.1327.1436  
822512111930712 1.604.2126.1804.2088.2493.3009.1631.3422.2698.1171.1272.0561.0843  
822512111930713 7.973.722.0791.0646.0645.0907.1017.1073.1348.1461.1870.2961.2240  
822512111930714 2.711.2450.1931.2809.2358.4730.0209.0834.0355.0164.0170.0522.0336  
822512111930715 7.971.526.2275.1801.1987.2256.2681.2040.3090.2466.2409.3124.2540  
822512111930716 1.721.1350.0936.0688.1862.0804.0774.0510.0271.0108.0143.0071.0059  
822512111930717 8.434.653.0452.0476.0472.0759.1273.1549.3461.4475.8145.8047.034  
822512111930718 1.01.1381.5401.4771.2342.1031.1002.8002.414.8991.000.4780.7426  
822512111930721 8.687.071.0529.0462.0498.0461.0603.3662.0751.0970.0978.1248.1210  
822512111930722 1.304.1837.2120.2071.2070.3367.2056.4073.3008.1102.1089.0634.0943  
822512111930723 8.684.504.0781.0713.0809.1016.1164.1290.1367.1715.2388.3104.2386  
822512111930724 2.577.2887.1717.2219.2192.3401.0364.1493.0229.0179.0285.0757.0747  
822512111930725 8.682.409.1873.1330.1493.2081.2658.1620.2909.2962.2579.2578.2515

LAKE UNION INTENSIVE MEASUREMENT PROGRAM POWER SPECTRA (continued)

824A12111930726.1924.2026.1521.0731.1691.0831.0858.0687.0206.0142.0144.0019.0109  
 824A1211193073110.648.912.0438.0451.0464.0516.0591.0700.0694.0767.0862.1068.1157  
 824A12111930732.1291.1759.2462.2598.2344.2945.2285.3771.2375.1272.1540.0932.1007  
 824A1211193073310.663.877.1205.0984.1075.1018.0957.1067.1500.1798.1654.2774.2336  
 824A12111930734.2594.2998.2021.3043.1530.2881.0257.0603.0303.0148.0203.1368.1017  
 824A1211193073510.663.350.1764.1716.1528.1988.2445.2745.2673.2451.2492.2550.2977  
 824A12111930736.1800.1864.2134.0741.1280.0880.0783.0593.0239.0179.0095.0073.0157  
 824A1211193074112.4910.05.0484.0385.0390.0451.0476.0600.0831.0743.0972.1121.1301  
 824A12111930742.1999.1768.2585.2521.1783.2446.2168.3021.1729.0996.1142.1035.1863  
 824A1211193074312.483.718.0892.0650.0675.0779.0829.1081.1584.1912.1795.1952.2568  
 824A12111930744.3138.2733.1769.4360.2208.1734.0804.0594.0678.0229.0249.1167.0805  
 824A1211193074512.442.436.1040.0936.1055.1073.1399.1732.2353.2078.2358.3384.2859  
 824A12111930746.3000.2102.2769.1436.1302.1110.1133.0419.0233.0172.0112.0233.0484  
 825A12112130711 8.668.778.0472.0409.0415.0581.0525.0587.0700.0711.1232.1360.1319  
 825A12112130712.1904.2114.1451.2455.2702.2584.1495.2253.1259.1670.0722.1376.1645  
 825A12112130713 8.664.368.0768.0664.0776.0977.0935.1300.1531.1352.1931.2321.1995  
 825A12112130714.2580.2629.2686.2113.2529.1271.0930.1487.0994.0492.0337.0214.0727  
 825A12112130715 8.661.709.2132.1741.1765.2310.2910.3376.2766.2973.2255.3072.2486  
 825A12112130716.1261.1761.0265.0987.0954.0510.0632.0782.0120.0132.0332.0166.0009  
 825A121121307179.2878.925.0534.0490.0541.0957.1476.2221.3121.4532.85281.1191.209  
 825A121121307181.2441.8891.5173.3272.4372.2601.5171.4251.3521.515.64571.4311.764  
 825A12112130719 9.008.111.0669.0465.0448.0445.0529.0739.0753.0808.1207.1195.1475  
 825A12112130720.1634.1780.1314.2412.2766.2627.1282.2488.1480.1806.0836.1440.1722  
 825A12112130721 9.004.456.1216.0960.1010.1097.1244.1344.1547.1774.1943.2369.1905  
 825A12112130722.3029.2509.2153.2479.2056.1392.1239.1792.0734.0416.0212.0195.0539  
 825A12112130723 9.002.420.4841.4618.4739.4210.5894.7345.6142.6336.6776.6668.6334  
 825A12112130724.5607.4217.3922.2794.2430.1289.2043.0887.0697.0453.0753.0422.0113  
 825A1211213072511.5110.54.0321.0648.0417.0499.0567.0679.0707.0902.1060.1173.1141  
 825A12112130726.1795.1480.1469.3079.2662.2182.1078.2988.1880.2066.1637.2129.1621  
 825A1211213072711.474.423.1132.0895.1019.1134.1328.1611.1457.1837.2059.2807.1865  
 825A12112130728.2807.2269.1634.2016.2181.1737.1693.1462.0474.0101.0019.0173.0645  
 825A1211213072911.574.911.1510.1580.1462.1831.2366.2196.2634.2149.2288.2478.2346  
 825A12112130730.2711.2275.1407.1619.1694.1128.0481.0552.0177.0121.0331.0207.0048  
 825A1211213073113.9110.54.0591.0454.0477.0428.0476.0796.0774.0920.1990.1474.1944  
 825A12112130732.1725.1494.2554.2633.2321.1249.1531.2127.1618.1304.1290.1959.1281  
 825A1211213073311.215.488.0870.0804.0804.0920.1082.1086.1906.1903.2209.2767.2320  
 825A12112130734.2261.2583.2058.2404.2127.1290.1612.2001.0340.0189.0121.0250.0613  
 825A1211213073513.012.024.6104.4457.4021.6277.2406.04111.017.06271.0281.2921.300  
 825A12112130736.8141.022.0247.5342.3900.4160.2849.2247.0742.0511.0470.0273.0084  
 9-2112131905711 3.641.109.0252.0235.0270.0283.0385.0488.0509.0554.0473.0817.1067  
 9-2112131905712.1200.2294.1637.1180.3670.1296.2444.5665.3870.2835.2122.1047.1221  
 9-2112131905713 3.640.267.1282.1216.1188.1256.1196.1045.1391.1445.1729.1440.1744  
 9-2112131905714.1474.1497.2058.1057.2281.1227.0030.1475.0820.0864.0577.0402.0648  
 9-2112131905715 3.64.2120.1666.1071.1115.1168.1463.2110.2706.2493.2634.2498.2362  
 9-2112131905716.1874.1200.1587.1388.1359.1172.0776.0896.0922.0580.0266.0097.0246  
 9-2112131905717.4051.210.0195.0145.0113.0110.0107.0122.0119.0266.0298.0506.1035  
 9-2112131905718.1282.2508.1991.1619.4110.1621.3125.8099.5919.4369.3062.1472.1688  
 9-2112131905719 4.241.348.0317.0255.0247.0288.0376.0447.0531.0588.0656.0960.0877  
 9-2112131905722.1141.1559.1689.1428.3624.1597.2816.6260.4224.2565.2125.1451.1181

LAKE UNION INTENSIVE MEASUREMENT PROGRAM POWER SPECTRA (continued)

9-2112131905723 4.240.534.1234.0893.0765.0919.1077.1183.1315.1493.1770.2139.2832  
9-2112131905724 1.797.1699.2651.1360.2404.3417.0672.0968.1334.0763.0094.0313.0486  
0-2112131905725 4.24.3966.0812.0568.0677.0975.1173.1793.1997.2415.2963.2960.2746  
0-2112131905726 2.198.3026.2790.1496.2317.1330.0982.1310.0977.0524.0086.0216.0435  
9-2112131905731 4.761.125.0499.0379.0342.0361.0403.0457.0584.0754.1069.0789.0861  
9-2112131905732 1.603.1319.1494.1914.2812.2916.2541.0298.3516.1507.0972.0659.0985  
9-2112131905733 4.76.5064.1378.1212.1076.0980.1009.0949.1177.1272.1464.1705.2095  
9-2112131905734 2.075.2780.1985.2811.1867.2622.1174.0635.1297.0782.0104.0162.0768  
9-2112131905735 4.74.5284.1014.0731.0840.0966.1179.1376.1731.2449.2259.3169.2723  
9-2112131905736 2.877.2904.2130.1539.1761.1097.1047.1501.1288.0747.0239.0439.0447  
9-2112131905741 5.541.228.0478.0364.0356.0363.0431.0488.0673.0775.0936.0983.1307  
9-2112131905742 1.065.1694.1740.1507.4265.2203.2399.5496.3546.1156.1034.1333.1294  
9-2112131905743 5.540.325.1855.1899.1397.1239.1197.0875.1028.1316.1503.2114.1525  
9-2112131905744 1.725.2008.1904.2422.2518.2604.1387.0689.0891.0468.0315.0352.0727  
9-2112131905745 5.54.2127.1600.1498.1205.1216.1111.1408.1533.1340.1863.2600.2051  
0-2112131905746 1.970.2838.1981.1545.1695.0937.1140.1668.2217.1167.0255.0755.0725  
9-3112180817711 1.44.4917.0543.0536.0452.0789.0387.0375.0436.0419.0470.0577.0652  
9-3112180817712 0.811.1585.0998.1304.2091.1726.2114.2288.2679.1199.0970.1682.1602  
9-3112180817713 1.44.0834.3193.2632.1862.1491.1192.0936.0774.0838.0624.0691.0781  
0-3112180817714 0.877.0850.0524.1385.2045.2684.0491.2150.1256.1766.2240.2730.1253  
9-3112180817715 1.44.0318.4212.3320.2482.1956.1670.1906.2125.2013.2079.2406.2118  
9-3112180817716 2.273.1344.1375.1842.1750.1255.0310.0390.0408.0430.0502.0088.0037  
0-3112180817717 1.330.4192.0240.0107.0137.0000.0076.0052.0060.0058.0077.0097.0068  
0-3112180817718 0.234.0531.0375.0468.0768.1787.1678.1182.2680.0654.0687.1851.1274  
9-3112180817721 1.43.5521.0459.0371.0309.0303.0284.0286.0396.0602.0451.0472.0825  
9-3112180817722 0.681.1079.1041.1415.1767.1499.1494.2179.3136.0909.0977.2198.2056  
9-3112180817723 1.63.1423.1449.1449.1088.0752.0698.0770.0580.0600.0415.0489.0714  
9-3112180817724 1.047.1121.1262.0926.1591.3875.0437.1968.2159.2340.1778.2876.1856  
9-3112180817725 1.63.0726.1524.1220.0971.0847.0802.0801.0873.1256.2146.2146.2729  
0-3112180817726 2.354.2318.3547.1722.1645.1050.1173.0894.1441.0024.0445.0019.0063  
0-3112180817727 1.25.0430.0833.0811.0540.0617.0399.0363.0344.0087.0419.0390.0497  
9-3112180817728 1.162.0977.1272.1079.0571.1758.1864.2414.4360.0383.0418.1707.2071  
9-3112180817731 1.79.1908.1932.1497.1065.0772.0700.1944.0682.0496.0584.0654.0730  
0-3112180817734 0.783.1103.1068.0527.1845.2257.0891.0610.2865.3053.2470.2984.2036  
9-3112180817735 1.79.1087.1895.1406.1070.0090.0876.1876.0894.1096.1089.1761.1454  
0-3112180817736 1.914.1570.4137.2126.1774.1626.2575.1162.2691.1066.0718.0069.0074  
0-3112180817741 2.18.3540.0008.0841.0446.0527.0435.3396.0443.0547.0544.0320.0577  
0-3112180817742 1.013.0931.1168.1600.1430.0831.0764.1437.1797.2147.1248.1524.1482  
0-3112180817743 2.18.1247.3158.2750.1016.1520.1293.3859.0630.0559.0613.0413.0603  
9-3112180817744 0.557.0425.0546.0776.1046.0355.0440.1268.3147.2451.3378.4108.2074  
9-3112180817745 2.18.1106.1387.1396.1086.0009.0712.3690.0025.0721.1070.1281.1295  
0-3112180817746 1.450.1874.2151.0063.2237.2789.2057.1604.2737.1646.0787.0068.0135  
1011121920000711 2.12.0596.0537.0334.0386.0300.0376.3387.0476.0636.0807.0650.0623  
1011121920000712 0.884.1167.0804.1608.1741.2469.2641.1949.2187.1487.0735.0458.3200  
1011121920000713 2.12.3019.1351.1165.0845.0770.0582.0687.0734.0695.0986.1028.1737  
1011121920000714 1.227.1253.1038.1132.2713.1491.1457.1947.2849.2482.2787.2144.0681  
1011121920000715 2.12.0610.1962.1615.1395.1238.1426.1507.1987.1911.2641.2541.3278  
1011121920000716 1.089.2396.1606.1899.2133.1191.0662.0415.0833.1049.0403.0033.0195  
1011121920000717 1.509.7427.0228.0200.0161.0100.0090.0099.0060.0071.0089.0182.0235

LAKE UNION INTENSIVE MEASUREMENT PROGRAM POWER SPECTRA (continued)

101112192000718.0251.0713.0547.0979.0945.1791.2007.93.1311.1035.0946.0719.3161  
 101112192000721 2.54.6041.0300.0288.0259.0256.0311.0273.0357.0480.0523.0554.0539  
 101112192000722.0675.1096.0875.0934.1638.1658.3153.4559.2463.1911.1016.0682.3972  
 101112192000723 2.54.3949.0775.0714.0551.0548.0535.0575.0697.0793.0972.1350.1726  
 101112192000724.1268.1302.1405.1244.2001.1526.1009.1481.2927.2425.4016.2581.0671  
 101112192000725 2.54.1270.1142.0811.0676.0733.0695.1151.1647.1577.2232.1843.2664  
 101112192000726.2641.2135.2198.2308.1738.1778.1475.1400.1514.1263.0486.0126.0449  
 101112192000731 2.95.6565.0498.0384.0315.0312.0297.0294.0375.0454.0578.0519.0776  
 101112192000732.0831.1029.0825.1919.3386.2077.3858.4355.3985.1239.0279.1032.2166  
 101112192000733 2.95.3054.1313.1184.0943.0777.0781.0905.0871.1016.0990.0940.1611  
 101112192000734.1207.1477.1724.1802.2986.1705.1403.1243.2560.0750.3414.2366.0410  
 101112192000735 2.95.1977.1058.0874.0682.0695.0831.0900.1202.1427.2148.2152.2120  
 101112192000736.2594.2572.1832.1823.1605.2101.1407.1486.1824.0823.0561.0738.0897  
 101112192000741 3.12.6500.0595.0360.0338.0291.0311.0296.0359.0375.0387.0360.0649  
 101112192000742.0563.0973.1160.0974.2677.2879.4068.5418.4902.1210.0580.0747.0965  
 101112192000743 3.12.1765.2740.2119.1727.1414.1223.0843.1046.0949.1052.1288.1583  
 101112192000744.1169.2112.1634.2044.3045.1504.1878.2621.2274.0715.0825.0487.0219  
 101112192000745 3.12.2246.0867.0806.0639.0561.0644.0708.0998.1102.1455.1524.2582  
 101112192000746.2099.3236.1842.3401.1968.2312.1956.3014.1324.0829.0373.0269.0867  
 101212190120711 2.54.3382.0684.0538.0472.0600.0666.0760.0859.1109.1162.1498.1463  
 101212190120712.1546.2231.2035.3383.2452.3556.2973.1470.0394.0181.0236.1697.1616  
 101212190120713 2.54.1801.2614.1854.1528.1205.1223.1112.1482.1242.1572.1121.1582  
 101212190120714.1655.2253.1712.2311.3358.1341.1008.0561.0324.0621.0785.0634.0284  
 101212190120715 2.54.1133.1147.1020.0965.0988.1131.1888.2102.2004.2495.2684.4570  
 101212190120716.2500.2740.3198.1787.1185.0644.0343.0569.0436.0344.0193.0259.0201  
 1012121901207171.981.4514.0212.0157.0121.0098.0075.0078.0081.0097.0128.0216.0314  
 101212190120718.0406.0767.0948.1449.1036.1726.2155.0965.0266.0167.0308.1558.1285  
 101212190120721 2.88.4170.0541.0477.0445.0487.0544.0719.0728.0948.1376.1192.1851  
 101212190120722.1624.1510.2540.2979.2954.2244.2110.1730.0747.0922.0818.1952.1712  
 101212190120723 2.88.2645.1284.1062.1029.0901.1022.1131.1431.1337.2083.2141.2446  
 101212190120724.2058.2628.1749.2595.3211.1120.0251.0401.0500.0505.0597.1084.0719  
 101212190120725 2.88.1829.0790.0618.0610.0710.0798.1200.1790.2125.2993.2896.4290  
 101212190120726.3632.2771.3388.1526.0651.1305.0705.0692.0390.0267.0093.0186.0178  
 101212190120731 3.20.5264.0662.0616.0551.0544.0524.0743.0780.1281.1285.1357.1374  
 101212190120732.1925.1977.2419.1718.2391.1541.1386.1980.0944.2322.1516.2431.2099  
 101212190120733 3.20.4691.1164.0925.0725.0723.0723.1931.0898.1445.1660.1883.2321  
 101212190120734.1706.2892.3080.2620.2112.1140.1532.1731.0767.0833.0510.1515.1198  
 101212190120735 3.20.2993.1047.0747.0659.0837.1089.1289.1427.2268.2603.4193.3207  
 101212190120736.1811.3242.3986.1889.1344.0497.0640.1706.0797.0482.0304.0052.0047  
 101212190120741 3.78.9063.0501.0424.0407.0409.0478.0612.0631.0871.1332.1557.1523  
 101212190120742.1774.2248.2251.2568.2428.3003.4041.1690.0416.1322.0387.0435.1326  
 101212190120743 3.78.2062.2442.1891.1695.1463.1197.1130.1162.1398.1310.1752.2385  
 101212190120744.2449.2644.2007.1740.1607.3652.1290.1123.0496.0675.0226.0095.0074  
 101212190120745 3.78.2698.1042.0812.0722.0769.0909.1360.1397.1978.1725.2803.3775  
 101212190120746.2313.2993.1988.2161.2363.2087.1174.0553.0513.0615.0419.0065.0053  
 111112201608711 4.611.278.0517.0441.0473.0540.0735.0810.0882.1156.1651.1456.1639  
 111112201608712.1754.2512.2085.2520.2083.2265.2130.2386.1190.1215.0834.0679.1315  
 111112201608713 4.610.993.0488.0484.0570.0762.0870.1169.1407.1609.2250.1791.2551  
 111112201608714.2389.2722.1557.1973.1695.1931.2614.1376.1243.0775.0381.0166.0388

LAKE UNION INTENSIVE MEASUREMENT PROGRAM POWER SPECTRA (continued)

111112201608715 4.61.3748.1410.0990.1154.1296.1760.2236.3407.3165.2577.2928.2628  
 111112201608716 2464.2204.2824.0865.1117.0297.0310.0469.0304.0232.0384.0306.0090  
 1111122016087174.7221.231.0204.0150.0123.0120.0156.0227.0358.0680.1278.1357.1679  
 111112201608718.2222.3581.3358.3354.2811.3264.3009.3965.1906.1598.1207.1023.2070  
 111112201608721 5.451.412.0449.0515.0512.0585.0706.0850.1022.1278.1104.1486.2022  
 111112201608722.1503.3412.2240.2964.1301.1716.1945.2877.1471.1381.1141.0763.0895  
 111112201608723 5.451.220.0986.0620.0635.0836.1055.1100.1250.1483.2100.2099.2434  
 111112201608724.2456.3343.1604.1856.2020.1839.1781.1146.0664.0658.0482.0147.0446  
 111112201608725 5.45.5970.0928.0763.0843.1214.1766.2377.2186.3123.3068.3232.2931  
 111112201608726.2487.2813.2351.1402.0860.0664.0384.0493.0421.0120.0241.0246.0080  
 111112201608731 6.161.530.0788.0676.0610.0657.0654.0799.0807.1039.1074.1451.1669  
 111112201608732.2436.2550.2626.3037.1749.1859.2100.3361.1129.1005.1291.0846.0469  
 111112201608733 6.161.360.1030.0766.0786.0877.0961.1052.1353.1774.1594.1540.2473  
 111112201608734.2699.2629.1843.2545.1564.1877.0928.0750.0667.0791.0320.0131.0445  
 111112201608735 6.16.8867.1345.0913.1026.1463.1882.2046.2050.2721.2406.4317.3220  
 111112201608736.3168.3374.1926.0773.1313.0701.0757.0381.0290.0182.0098.0054.0029  
 111112201608741 6.391.360.0668.0601.0540.0604.0731.0862.1091.1058.1534.1398.1837  
 111112201608742.1825.2527.2797.1608.3441.1336.1465.3066.1259.0887.1081.1471.0943  
 111112201608743 6.391.140.0763.0660.0663.0633.0857.1044.1331.1608.1866.1976.2352  
 111112201608744.3050.1887.2258.1997.2257.1331.0990.0475.0210.0295.0221.0400.0565  
 111112201608745 6.39.7328.0783.0841.0892.1093.1526.1989.2270.2855.2609.3054.2984  
 111112201608746.2332.2275.2858.1929.1658.0666.0687.0735.0523.0172.0263.0116.0122  
 121101131800711 4.761.934.0343.0323.0300.0428.0531.0710.0815.0815.1107.1324.1615  
 121101131800712.1515.1996.2251.2050.2571.1881.1435.1603.2875.3769.0806.0334.0688  
 121101131800713 4.76.9727.0774.0568.0529.0625.0694.0810.1039.1364.1683.1990.2107  
 121101131800714.2171.3317.3072.3559.1841.1769.2362.1819.0326.0362.0637.0243.0885  
 121101131800715 4.76.4367.1043.0951.0974.1616.2348.2525.3270.2854.3282.2861.3005  
 121101131800716.2572.2087.1779.1010.0624.0557.0886.0410.0390.0338.0197.0017.0058  
 1211011318007174.8241.931.0119.0113.0104.0121.0148.0303.0359.0645.1322.1783.2446  
 121101131800718.2453.4203.4042.4206.5595.5499.3961.4309.9079.9048.2255.0995.1141  
 121101131800721 5.432.206.0321.0320.0333.0376.0518.0666.0717.0886.1286.1446.1599  
 121101131800722.1466.1595.1825.2637.2727.1945.1486.1749.4053.3206.0641.0449.0565  
 121101131800723 5.431.188.0806.0548.0582.0653.0875.1124.1500.1455.1741.2093.2382  
 121101131800724.2106.2285.2916.4155.2148.1621.2017.1916.0618.0241.0482.0470.0553  
 121101131800725 5.43.6720.1376.0783.1035.1315.1605.2200.2750.3067.3096.3054.2979  
 121101131800726.2512.2016.1651.1091.1269.0889.0767.0603.0643.0420.0363.0145.0206  
 121101131800731 6.402.288.0322.0344.0318.0426.0460.0612.0654.1020.1109.0950.1296  
 121101131800732.1593.1507.2264.2370.2646.1785.1475.1673.4455.4088.0482.0621.0743  
 121101131800733 6.401.563.0829.0559.0567.0750.0908.0987.1322.1304.1576.1274.2290  
 121101131800734.2244.1942.1948.4270.3309.2132.2282.2064.0345.0417.0885.0540.0220  
 121101131800735 6.40.9392.1059.0956.0917.1069.1640.1609.1887.2383.3260.3172.2751  
 121101131800736.2006.2216.1484.0992.1534.1065.0942.0929.0687.0709.0331.0082.0123  
 121101131800741 7.562.245.0536.0404.0407.0488.0671.0560.0768.0939.1144.1458.1330  
 121101131800742.1654.1646.2099.1545.1122.1825.1870.2122.4127.1760.0831.2128.1348  
 121101131800743 7.561.082.0560.0598.0618.0671.0722.1011.1017.1045.1433.2046.1719  
 121101131800744.2845.2463.2085.4033.3044.2248.2113.2166.0437.0821.0405.0207.0247  
 121101131800745 7.56.6746.0979.0731.0792.0978.1241.1672.1917.2058.2631.2881.2360  
 121101131800746.2585.2372.2363.2034.1440.1281.1021.1223.0810.0817.0273.0363.0474  
 121A01132020711 4.231.382.0337.0291.0337.0460.0540.0642.0784.0908.1105.1308.1425

LAKE UNION INTENSIVE MEASUREMENT PROGRAM POWER SPECTRA (continued)

121A01132020712, 2.008, 1.605, 2.262, 2.149, 1.393, 2.976, 3.116, 2.965, 1.884, 1.597, 1.096, 0.981, 0.410  
 121A01132020713, 4.23, 8.517, 0.657, 0.423, 0.432, 0.497, 0.567, 0.703, 0.896, 0.919, 1.067, 1.549, 1.802  
 121A01132020714, 1.830, 3.234, 3.150, 2.149, 2.062, 2.430, 2.104, 1.534, 3.523, 1.200, 1.115, 0.442, 0.237  
 121A01132020715, 4.23, 3.529, 0.702, 0.739, 0.813, 1.108, 1.392, 2.097, 2.740, 2.563, 2.971, 2.734, 2.947  
 121A01132020716, 3.449, 2.944, 1.502, 1.980, 1.122, 0.764, 1.077, 0.424, 0.227, 0.124, 0.106, 0.094, 0.188  
 121A01132020717, 2.971, 3.342, 0.124, 0.094, 0.078, 0.083, 0.123, 0.192, 0.318, 0.408, 0.675, 1.229, 1.552  
 121A01132020718, 2.752, 2.585, 3.222, 2.910, 2.567, 5.187, 4.661, 4.466, 2.716, 2.618, 1.908, 1.647, 0.756  
 121A01132020721, 4.801, 6.72, 0.349, 0.318, 0.333, 0.401, 0.464, 0.632, 0.652, 0.827, 0.901, 1.357, 1.350  
 121A01132020722, 1.741, 1.718, 2.195, 2.997, 2.621, 3.294, 2.680, 3.124, 1.659, 1.148, 1.065, 0.931, 0.564  
 121A01132020723, 4.800, 8.84, 0.724, 0.486, 0.558, 0.668, 0.885, 0.983, 1.136, 1.489, 1.696, 2.289, 2.066  
 121A01132020724, 1.816, 2.604, 3.295, 1.328, 1.284, 2.417, 1.583, 1.723, 3.083, 0.875, 1.088, 0.335, 0.252  
 121A01132020725, 4.80, 5.874, 0.500, 0.585, 0.683, 0.975, 1.274, 1.738, 2.250, 2.480, 2.940, 2.296, 3.057  
 121A01132020726, 3.505, 3.028, 1.812, 2.572, 1.188, 0.815, 1.614, 0.439, 0.130, 0.143, 0.198, 0.142, 0.236  
 121A01132020731, 5.801, 9.34, 0.445, 0.327, 0.358, 0.415, 0.409, 0.545, 0.767, 0.702, 1.060, 1.270, 1.457  
 121A01132020732, 1.658, 2.139, 2.170, 2.989, 1.769, 2.539, 2.654, 2.183, 2.006, 0.816, 0.759, 0.722, 0.314  
 121A01132020733, 5.801, 0.60, 0.914, 0.701, 0.842, 0.804, 0.964, 1.314, 1.289, 1.477, 2.059, 2.089, 2.292  
 121A01132020734, 2.537, 2.946, 3.363, 2.694, 1.254, 1.698, 0.993, 1.279, 2.011, 0.747, 0.453, 0.234, 0.141  
 121A01132020735, 5.80, 8.184, 0.871, 0.803, 0.924, 1.134, 1.436, 1.772, 2.179, 2.963, 2.589, 2.183, 2.537  
 121A01132020736, 2.697, 2.829, 1.541, 2.587, 0.909, 1.366, 1.337, 0.318, 0.214, 0.345, 0.307, 0.050, 0.237  
 121A01132020741, 6.742, 1.34, 0.304, 0.313, 0.338, 0.359, 0.424, 0.575, 0.665, 0.819, 0.912, 1.228, 1.373  
 121A01132020742, 1.632, 2.028, 1.339, 2.077, 2.691, 2.413, 1.455, 5.570, 2.273, 1.714, 1.195, 1.185, 0.656  
 121A01132020743, 6.74, 6.656, 0.765, 0.691, 0.685, 0.830, 0.825, 0.956, 1.258, 1.667, 2.284, 2.152, 2.334  
 121A01132020744, 2.421, 2.963, 3.829, 2.654, 1.424, 1.403, 1.905, 1.579, 1.572, 0.889, 0.190, 0.168, 0.132  
 121A01132020745, 6.74, 6.139, 0.907, 0.681, 0.756, 0.852, 0.938, 1.213, 1.546, 1.773, 2.274, 2.405, 2.548  
 121A01132020746, 2.852, 2.455, 2.140, 2.774, 0.793, 1.864, 1.874, 1.158, 0.701, 0.944, 0.440, 0.060, 0.391  
 121301132320711, 4.551, 6.08, 0.374, 0.279, 0.339, 0.418, 0.493, 0.602, 0.698, 0.944, 0.698, 1.572, 1.752  
 121301132320712, 1.965, 2.705, 1.714, 1.675, 1.943, 2.636, 2.507, 1.990, 0.812, 2.153, 1.389, 3.055, 2.389  
 121301132320713, 4.55, 6.319, 0.796, 0.653, 0.645, 0.731, 0.844, 1.101, 1.589, 1.919, 2.067, 2.617, 2.062  
 121301132320714, 2.494, 2.578, 2.321, 2.134, 2.849, 1.666, 1.869, 1.842, 0.506, 0.880, 0.818, 0.259, 0.165  
 121301132320715, 4.55, 4.111, 0.966, 0.910, 0.941, 1.323, 1.712, 2.234, 2.981, 3.943, 3.057, 2.989, 3.163  
 121301132320716, 2.294, 2.556, 1.497, 1.375, 0.559, 0.553, 0.553, 0.531, 0.210, 0.577, 0.498, 0.078, 0.137  
 121301132320717, 4.931, 5.20, 0.114, 0.101, 0.094, 0.093, 0.136, 0.195, 0.316, 0.529, 0.725, 1.624, 1.916  
 121301132320718, 2.746, 4.062, 2.650, 3.085, 3.618, 5.002, 4.549, 3.602, 1.449, 3.546, 2.238, 5.750, 4.487  
 121301132320721, 5.232, 1.09, 0.340, 0.255, 0.291, 0.336, 0.458, 0.542, 0.688, 0.797, 0.856, 1.230, 1.823  
 121301132320722, 1.957, 2.186, 1.717, 1.646, 1.948, 2.333, 3.115, 1.551, 1.016, 2.041, 1.619, 3.497, 2.765  
 121301132320723, 5.23, 8.953, 0.839, 0.560, 0.563, 0.757, 0.962, 1.338, 1.274, 1.895, 1.732, 2.767, 2.430  
 121301132320724, 2.549, 2.524, 2.295, 2.104, 2.743, 2.503, 1.812, 1.297, 0.467, 0.456, 0.331, 0.620, 0.371  
 121301132320725, 5.23, 7.231, 0.991, 0.578, 0.707, 1.055, 1.603, 1.761, 2.510, 2.911, 2.665, 3.565, 3.962  
 121301132320726, 2.304, 1.988, 1.760, 1.475, 1.057, 0.752, 0.983, 0.717, 0.481, 0.511, 0.316, 0.414, 0.422  
 121301132320731, 6.252, 2.22, 0.349, 0.295, 0.309, 0.370, 0.438, 0.583, 0.553, 0.735, 1.009, 1.369, 1.387  
 121301132320732, 1.454, 2.447, 1.728, 1.330, 1.084, 2.255, 2.565, 0.807, 1.283, 2.467, 1.906, 4.433, 3.227  
 121301132320733, 6.251, 1.05, 0.940, 0.679, 0.831, 0.960, 1.203, 1.392, 1.404, 1.767, 2.103, 2.357, 2.544  
 121301132320734, 1.959, 2.417, 2.952, 2.219, 3.249, 1.977, 1.133, 0.758, 1.558, 1.297, 0.263, 0.112, 0.118  
 121301132320735, 6.25, 8.732, 0.991, 0.856, 0.885, 1.270, 1.286, 1.979, 2.269, 2.719, 3.005, 2.887, 2.800  
 121301132320736, 2.578, 2.370, 2.053, 1.572, 1.018, 1.130, 0.760, 0.920, 0.530, 0.473, 0.142, 0.339, 0.320  
 121301132320741, 7.491, 9.73, 0.540, 0.372, 0.337, 0.458, 0.486, 0.655, 0.792, 1.014, 1.146, 1.158, 2.008  
 121301132320742, 2.055, 1.866, 2.096, 1.205, 0.461, 1.334, 0.930, 0.750, 1.673, 3.255, 1.338, 4.253, 2.888  
 121301132320743, 7.491, 2.40, 0.683, 0.471, 0.555, 0.646, 0.731, 0.984, 1.358, 1.566, 1.984, 2.586, 2.695  
 121301132320744, 1.812, 3.547, 2.159, 2.003, 4.146, 1.665, 0.996, 0.830, 1.507, 1.166, 0.358, 0.650, 0.518

LAKE UNION INTENSIVE MEASUREMENT PROGRAM POWER SPECTRA (continued)

121301132320745 7.49.6315.1164.0829.0884.1165.1337.1866.2037.2809.2820.2549.3179  
 121301132320746 1.990.1367.1840.0965.0906.1247.0869.0568.0436.0489.0155.0777.0515  
 121401140220711 3.46.9522.0202.0254.0302.0395.0491.0602.0664.0821.1011.1172.1814  
 121401140220712 1.394.1658.1899.2439.2877.4547.1552.2904.0949.0497.0227.0254.0448  
 121401140220713 3.46.4478.1262.0664.0622.0701.0855.1070.1520.1691.1778.1742.2235  
 121401140220714 2.373.3562.2718.3552.3137.1367.1156.1083.0690.0704.0608.0254.0217  
 121401140220715 3.46.9522.0767.0646.0814.1006.1312.1986.2188.2626.3256.3649.3566  
 121401140220716 3.309.1800.1923.1647.1008.0700.0869.0445.0620.0310.0241.0150.0078  
 121401140220717 2.90.9232.0105.0081.0062.0059.0069.0009.0152.0227.0449.0637.1257  
 121401140220718 1.209.1516.2089.2409.2903.5208.1639.2254.1041.0600.0430.0288.0571  
 121401140220721 3.981.070.0300.0298.0325.0378.0594.0694.0842.0886.1487.1622.1705  
 121401140220722 1.608.1928.1269.2421.2243.4762.1110.2934.0944.0661.0274.0096.0446  
 121401140220723 3.98.4652.0687.0610.0736.0803.0954.1123.1626.1913.1821.2385.1979  
 121401140220724 2.857.2731.2415.3392.2925.1784.0997.0905.0316.1047.0527.0145.0239  
 121401140220725 3.98.4320.0535.0481.0641.0707.1330.1668.2030.2859.2884.2681.3959  
 121401140220726 3.004.2170.2313.2059.1524.0792.0793.0594.0714.0361.0150.0236.0131  
 121401140220731 4.941.335.0308.0328.0349.0428.0558.0649.0961.0841.0830.0861.2100  
 121401140220732 1.736.1379.2949.4591.2220.5545.2292.2168.0645.0153.0403.0426.0270  
 121401140220733 4.94.9052.1030.0667.0683.0883.0950.1234.1554.1922.1808.2215.2356  
 121401140220734 3.408.3084.2576.2564.2347.1154.1281.0764.0532.0514.0252.0235.0144  
 121401140220735 4.94.6529.0824.0653.0803.1043.1354.1730.2011.2147.2708.2995.2679  
 121401140220736 3.279.2317.2508.1911.1489.1338.0564.0739.0493.0649.0217.0348.0236  
 121401140220741 6.411.256.0494.0432.0434.0585.0627.0839.0962.1089.1539.1336.1737  
 121401140220742 2.126.2998.3032.2127.2777.3522.2137.1335.0952.0945.2357.0951.0369  
 121401140220743 6.41.9307.0750.0600.0654.0712.1098.1365.1382.1615.2181.2449.2532  
 121401140220744 2.776.3258.1975.1957.3435.3036.1008.0908.0138.0136.0060.0109.0416  
 121401140220745 6.41.5220.0805.0758.0778.1019.1247.1368.1991.2109.2737.2486.2162  
 121401140220746 2.844.2028.4177.1687.2459.1266.0583.0529.0389.0740.0183.0327.0307  
 121501140520711 0.75.1618.0763.0519.0388.0323.0289.0279.0285.0370.0472.0777.0668  
 121501140520712 0.614.0826.1624.1902.1004.2183.2156.2367.3065.3655.1014.2259.2976  
 121501140520713 0.75.1406.0786.0860.0625.0481.0457.0370.0359.0483.0426.0572.0497  
 121501140520714 0.932.1039.0914.1172.2304.0746.0645.0741.0237.1023.1145.1067.3125  
 121501140520715 0.75.0412.2084.1818.1289.1056.0833.0998.0910.1043.1195.1667.2634  
 121501140520716 2.348.1800.1906.1325.2830.1705.1974.1668.1135.1599.1310.0796.0585  
 121501140520717 2.413.1156.0375.0238.0213.0170.0123.0109.0060.0051.0054.0059.0046  
 121501140520718 0.056.0063.0076.0181.0215.0210.0254.0237.0489.0218.0042.0088.0152  
 121501140520721 1.00.2479.0464.0330.0237.0225.0235.0231.0271.0394.0659.0554.0668  
 121501140520722 0.953.1181.1050.1867.1081.1744.1689.1988.2678.2742.1086.2952.4038  
 121501140520723 1.00.1683.0765.0738.0558.0412.0386.0361.0442.0554.0461.0646.0739  
 121501140520724 0.814.1323.1607.1560.1572.1053.0469.0967.0603.1119.1134.0695.2866  
 121501140520725 1.00.0722.1079.0640.0471.0490.0514.0435.0818.0942.1781.1263.2504  
 121501140520726 2.172.1900.2790.1751.2468.2301.1189.2076.1505.1842.1151.0877.0633  
 121501140520731 1.50.3585.0431.0378.0304.0249.0233.0289.0286.0513.0390.0831.0622  
 121501140520732 0.939.1342.1636.1460.2565.1122.2194.1437.1093.1608.2564.3683.2409  
 121501140520733 1.50.3065.0722.0457.0389.0348.0373.0398.0460.0605.0745.0887.0914  
 121501140520734 0.814.2386.1292.1275.1180.2094.1815.1313.1134.1369.1132.1504.3335  
 121501140520735 1.50.1115.1040.0757.0651.0668.0752.0874.1092.1181.1803.1087.3026  
 121501140520736 1.702.2636.3096.2544.1398.2291.0752.1234.0698.1758.0184.0144.1023  
 121501140520741 1.95.6162.0256.0207.0197.0180.0181.0242.0369.0297.0393.0544.0623

LAKE UNION INTENSIVE MEASUREMENT PROGRAM POWER SPECTRA (continued)

121501140520742.1117.0968.0989.2296.2631.2069.1376.1849.0672.2556.1572.1428.1087  
121501140520743 1.95.2458.0634.0535.0489.0469.0420.0483.0691.0712.0966.0989.1185  
121501140520744.1581.1468.1761.1837.2395.1781.1925.1554.1358.1595.1314.1135.3519  
121501140520745 1.95.1002.1113.0852.0779.0594.0714.0713.1073.1188.1271.2171.2274  
121501140520746.2945.1968.1879.2570.4178.1426.1749.1613.0920.1507.0534.0173.0390  
131101140740711 6.442.968.0572.0424.0506.0610.0677.0896.1079.1195.1303.1351.1680  
131101140740712.1723.2245.1595.2917.2798.2962.2421.1405.0673.1005.1387.1472.0983  
131101140740713 6.441.524.0558.0598.0625.0758.0996.1142.1568.1681.1891.2134.2036  
131101140740714.2498.1681.2531.3350.1970.2537.2139.1197.0954.0372.0851.0872.0381  
131101140740715 6.44.7822.1079.1227.1450.2052.2796.2738.2920.3437.3920.2894.2130  
131101140740716.1717.1734.1294.1569.0621.0632.0274.0384.0712.0191.0121.0164.0096  
1311011407407176.7632.871.0190.0151.0165.0263.0412.0690.1290.1920.2686.3414.4748  
131101140740718.6263.7342.5213.9477.96451.011.8109.5698.2427.3804.4818.4713.3137  
131101140740721 7.333.760.0354.0384.0420.0523.0556.0728.0782.1133.1167.1365.1599  
131101140740722.1815.2191.1884.2817.2744.2856.2396.1638.0845.1384.1807.1464.1114  
131101140740723 7.331.542.0673.0737.0715.0924.1183.1355.1861.1694.1545.2506.2153  
131101140740724.2901.1896.2123.3287.1540.2158.1445.1462.0578.0440.0760.0595.0281  
131101140740725 7.331.202.1295.1013.1086.1552.1939.2563.2713.4461.3745.3068.2376  
131101140740726.1929.2343.1636.1294.0728.0855.0493.0276.0262.0077.0038.0041.0048  
131101140740731 8.983.916.0441.0402.0416.0572.0497.0624.0794.0845.0790.1087.1223  
131101140740732.1554.2036.2482.2169.3531.2611.1754.1186.0844.1863.2346.1753.1542  
131101140740733 8.982.140.0757.0795.0897.0959.1123.1371.1257.1589.1986.2009.1873  
131101140740734.3267.2085.3233.3659.1673.1748.0874.1172.0752.0669.0155.0140.0292  
131101140740735 8.981.468.1727.1338.1448.1647.2167.2640.3065.2571.2476.2899.2378  
131101140740736.2104.2806.1854.1184.0594.0789.0416.0729.0246.0180.0034.0155.0168  
13110114074074110.124.157.0311.0380.0338.0432.0500.0570.0716.0734.0780.1008.1201  
131101140740742.1666.1217.2062.1317.3513.2238.2516.1338.0621.2899.3163.2018.1619  
13110114074074310.120.886.0965.0735.0787.0889.1191.1020.1675.1666.1532.2353.2534  
131101140740744.2565.3128.3205.2649.1057.1758.1084.1025.1293.1171.0208.0186.0159  
13110114074074510.121.421.1077.0845.0932.1285.1436.1766.2131.2022.2322.3252.3147  
131101140740746.2268.2657.2899.1311.2023.1063.0499.0782.0499.0650.0437.0096.0179

KIXI INTENSIVE MEASUREMENT PROGRAM POWER SPECTRA

K1-110311724011 9.903.343.0383.0354.0305.0306.0341.0352.0461.0495.0550.0532.0592  
 K1-110311724012.1069.0970.1240.2606.1566.1182.2051.2053.2706.2246.0195.0468.3726  
 K1-110311724013 9.901.691.0907.0706.0658.0592.0670.0616.0714.0876.0966.1421.1114  
 K1-110311724014.1197.2224.1437.3268.2776.1603.2023.2416.1389.2886.1734.0305.0813  
 K1-110311724015 9.907.7114.1749.1290.1394.1499.2060.1911.2183.2357.2002.2272.1590  
 K1-110311724016.1987.2658.1800.1368.2053.1610.0483.1351.0589.0534.0741.0388.0316  
 K1-110311724017 8.912.579.0597.0381.0314.0265.0300.0384.0590.0772.0889.1105.1203  
 K1-110311724018.2441.2316.2347.6337.4020.3428.4651.5351.6235.4719.0650.1357.9875  
 K1-110311724021 0.422.028.0249.0316.0262.0314.0364.0403.0403.0588.0610.0624.0784  
 K1-110311724022.0228.1179.1318.1991.2792.1799.1998.2653.2597.1494.0805.0678.3070  
 K1-110311724023 0.421.217.0820.0616.0544.0543.0619.0652.0753.0898.0872.1196.1313  
 K1-110311724024.1509.1975.2443.2910.2693.2157.2365.3314.0935.2539.1803.0490.0387  
 K1-110311724025 0.421.311.0671.0620.0749.0761.1047.1271.1602.1879.1966.2885.2133  
 K1-110311724026.2193.2612.2437.1541.2457.2592.1218.1653.0635.0892.1210.0512.0148  
 K2-111151129011 3.211.825.0090.0091.0105.0145.0218.0245.0283.0338.0531.0509.0649  
 K2-111151129012 3.223.0987.1162.1285.3125.1562.4689.3451.1181.1504.4505.3961.2571  
 K2-111151129013 3.211.117.0342.0271.0222.0242.0255.0310.0389.0438.0622.1068.1358  
 K2-111151129014.1112.1763.1981.2185.2480.5512.4886.3551.1285.1448.2396.1060.0478  
 K2-111151129015 3.21.4326.0718.0479.0419.0469.0559.0878.0999.1391.1390.1586.2587  
 K2-111151129016.2755.2202.2222.3756.3054.1786.0918.1106.1852.0542.0672.0539.0425  
 K2-111151129017 3.221.394.0247.0180.0125.0112.0086.0089.0099.0139.0288.0362.0602  
 K2-111151129018.0889.1068.1673.2007.4965.2327.5768.4290.1816.2173.6734.6368.4553  
 K2-111151129021 3.221.750.0328.0287.0278.0249.0299.0328.0371.0484.0677.0623.0902  
 K2-111151129022.0888.1004.1225.1565.1698.1903.2980.2553.1782.1489.3899.3812.2659  
 K2-111151129023 3.22.8102.0591.0536.0396.0364.0386.0403.0511.0630.1016.0935.1344  
 K2-111151129024.1305.2042.3017.2216.2377.3049.2797.3574.0975.1418.2891.1228.0402  
 K2-111151129025 3.22.0305.0489.0418.0349.0354.0384.0572.0801.0771.1123.1209.2029  
 K2-111151129026.3293.3129.2917.3532.2148.2332.1092.1070.0757.0157.0665.0872.0682  
 K2-211151211011 4.531.711.0216.0226.0272.0325.0484.0475.0655.0876.0878.0957.1291  
 K2-211151211012.1506.1618.1599.2963.2929.2131.4118.2690.1781.2325.1650.1178.1609  
 K2-211151211013 4.531.555.0194.0193.0207.0271.0323.0401.0649.0868.1020.1685.1777  
 K2-211151211014.2562.3182.1865.3238.2724.4049.1892.1711.1647.0505.0110.0573.0855  
 K2-211151211015 4.53.7911.0442.0409.0479.0535.0777.0998.1467.1411.2504.2284.2206  
 K2-211151211016.3083.2919.2298.2436.2224.1653.1851.2203.2085.0218.0377.0278.0072  
 K2-211151211017 4.551.106.0244.0365.0301.0209.0224.0148.0315.0325.0486.0448.0969  
 K2-211151211018.1702.2311.2049.3268.4525.2156.4759.3197.2377.2329.1363.1527.2316  
 K2-211151211021 5.292.162.0348.0315.0312.0357.0403.0539.0687.0687.1013.1062.1239  
 K2-211151211022.1239.1392.2275.2344.3128.1408.4348.2919.2763.0403.0810.0700.2208  
 K2-211151211023 5.221.556.0444.0466.0282.0357.0519.0584.0931.1087.1035.1459.1522  
 K2-211151211024.1500.2525.2612.4491.3622.1253.2193.2462.1675.1676.0597.0220.0224  
 K2-211151211025 5.221.371.0538.0496.0510.0543.0631.0709.1149.1393.1461.1740.2857  
 K2-211151211026.3372.2633.2966.2519.1970.2238.2007.2288.1856.0282.0158.0156.0212  
 K2-311151306011 4.531.311.0289.0248.0249.0331.0402.0488.0613.0597.0913.1210.1343  
 K2-311151306012.1273.1842.1934.0998.2021.2309.3716.4314.2276.3392.1277.0408.0668  
 K2-311151306013 4.531.007.0319.0287.0259.0313.0401.0550.0791.0711.1026.1391.1990  
 K2-311151306014.2445.2515.4004.3129.1934.3440.4240.0960.1325.1048.0746.0234.0297  
 K2-311151306015 4.53.6529.0651.0581.0512.0561.0827.1061.1473.1711.2077.2580.2161  
 K2-311151306016.2124.2314.2372.2160.3090.2244.2148.0916.0673.0675.0392.0319.0398  
 K2-311151306017 4.37.8364.0457.0246.0212.0176.0172.0131.0167.0187.0304.0602.0711

KIXI INTENSIVE MEASUREMENT PROGRAM POWER SPECTRA

K2-31151306018,1017,1626,1769,0868,1895,2544,3565,3810,2377,3063,1078,0297,0476  
 K2-31151306021 5,111,854,0495,0376,0314,0350,0318,0387,0605,0785,0995,0803,1231  
 K2-31151306022,1472,1248,2015,1978,2247,3294,4320,2573,1214,2423,2496,1504,0979  
 K2-31151306023 5,11,8080,0631,0554,0527,0536,0525,0593,0791,1062,1396,1615,1820  
 K2-31151306024,1599,2541,2573,3040,2928,3970,4080,0485,0724,0667,1051,0436,0512  
 K2-31151306025 5,111,041,0946,0562,0482,0521,0726,0772,1100,1269,1438,1940,2141  
 K2-31151306026,1020,2486,2668,2270,4389,2630,4283,0974,0887,0622,0412,0307,0360  
 K3-111271605011 9,605,070,0649,0532,0492,0580,0704,0715,0862,0935,1178,1320,1675  
 K3-111271605012,1454,1366,1269,4377,3032,1968,1961,0945,1389,1212,1029,2670,1823  
 K3-111271605013 9,605,433,0527,0386,0432,0432,0510,0800,0950,1063,1468,1894,1906  
 K3-111271605014,3093,2329,5437,4117,4562,2142,0792,0745,0720,0296,0075,0161,0197  
 K3-111271605015 9,601,880,0779,0909,1120,1323,1524,1902,2464,2948,2824,2205,2795  
 K3-111271605016,2271,1511,2039,1591,0706,1652,1378,0747,0447,0645,0620,0056,0106  
 K3-111271605017 9,604,512,1066,0924,0769,0785,1035,1370,2523,3296,3848,6267,8065  
 K3-111271605018,6962,6369,96462,0281,5951,044,8990,5345,6003,5662,44971,275,9157  
 K3-11127160502110,555,602,0650,0580,0489,0553,0710,0731,1041,0964,1244,1460,1502  
 K3-111271605022,2480,1989,2360,2914,3758,2971,2235,1124,0900,0907,0883,1711,1196  
 K3-11127160502310,555,432,0728,0540,0565,0630,0825,0915,1387,1745,1773,2402,2015  
 K3-111271605024,2603,2294,3457,4742,5053,1895,0515,0729,0341,0373,0102,0176,0238  
 K3-11127160502510,553,693,1130,0796,0868,1059,1412,1757,2100,2437,2270,3236,2799  
 K3-111271605026,2381,2269,2272,2361,0624,1461,1675,1188,0605,0485,0568,0280,0200  
 K4-111281039011 7,404,914,0660,0403,0409,0473,0469,0600,0679,0671,0979,1065,1468  
 K4-111281039012,1672,2328,2791,3075,3552,2972,1232,1640,2339,2128,0057,1680,1437  
 K4-111281039013 7,403,936,0598,0504,0403,0493,0629,0862,0881,1416,1406,1214,2104  
 K4-111281039014,3320,3419,3761,4025,1246,2036,1543,1789,0381,0600,1499,0893,0198  
 K4-111281039015 7,401,702,1533,1039,1082,1252,1684,1641,2207,2200,2028,2578,2705  
 K4-111281039016,2540,3440,2209,2514,0979,1344,0195,0595,0665,0320,0343,0413,0167  
 K4-111281039017 7,413,496,3210,1772,1528,1152,1070,1029,1107,1658,2197,2529,3936  
 K4-111281039018,5075,7577,0978,99561,2201,303,5306,74571,060,7229,0294,5279,4809  
 K4-111281039021 8,606,372,0674,0454,0440,0492,0587,0557,0759,0765,0964,1393,1394  
 K4-111281039022,1141,2570,2037,3891,3328,3645,1269,1229,3238,1810,0777,0741,0509  
 K4-111281039023 8,604,513,0885,0614,0543,0573,0770,0773,1127,0928,1356,1792,1613  
 K4-111281039024,2334,4044,2855,4815,3978,1857,1484,1414,0531,0261,0274,0141,0098  
 K4-111281039025 9,603,252,1183,0912,0964,1045,1307,1439,2202,2497,1834,2005,2240  
 K4-111281039026,2066,3623,2972,3027,1406,1552,0899,1546,0726,0286,0513,0433,0045  
 K4-211281259011 5,084,622,0248,0201,0244,0274,0326,1357,0544,0613,0679,0668,0767  
 K4-211281259012,1158,1453,1479,2044,2194,2236,1839,1845,0609,1601,0816,0363,0918  
 K4-211281259013 5,083,256,0430,0347,0316,0361,0466,1655,0708,1097,1198,1243,1727  
 K4-211281259014,1974,2735,2021,1070,2477,5494,3932,1000,0506,0688,0646,0799,0655  
 K4-211281259015 5,081,202,1605,0799,0742,1113,1237,1587,1866,1754,2066,2042,2040  
 K4-211281259016,2311,3613,2700,2273,1694,0754,1117,1707,1203,0427,0223,0185,0193  
 K4-211281259017 6,073,500,0773,0587,0469,0373,0364,0403,0679,0944,1372,1498,2166  
 K4-211281259018,3630,4987,5357,6730,9979,7937,8248,6752,2405,6052,3984,1168,3129  
 K4-211281259021 6,665,075,0507,0216,0328,0333,0360,0466,0600,0625,0769,0865,1024  
 K4-211281259022,1022,0914,1900,1532,2853,2027,1804,3491,0863,1217,1117,0815,0798  
 K4-211281259023 6,663,029,0663,0491,0502,0466,0674,0927,1208,1165,1558,1568,1926  
 K4-211281259024,2137,2661,2261,3783,2735,2123,2129,0954,0924,0468,0584,0339,0094  
 K4-211281259025 6,662,556,0898,0691,0610,0688,0982, 200,1377,1575,1412,1885,1434  
 K4-211281259026,2527,2732,2784,1745,3100,1283,2276, 647,1124,0668,0197,0128,0149

KIXI INTENSIVE MEASUREMENT PROGRAM POWER SPECTRA

K4-311291431011 7.173.406.0463.0337.0310.0343.0420.0465.0731.0675.0867.1131.1055  
 K4-311281431012 7.172.252.0380.0274.0311.0354.0341.0418.0632.0809.0823.0859.1495  
 K4-311291431013 7.172.252.0380.0274.0311.0354.0341.0418.0632.0809.0823.0859.1495  
 K4-311291431014 1490.2986.3145.3207.5766.4535.3087.1620.0260.0222.0322.1091.0808  
 K4-311291431015 7.171.364.1268.0866.0808.0980.1257.1473.1819.1513.1573.2007.2177  
 K4-311291431016 2189.4054.2435.3107.2364.1567.1790.0821.0690.0262.0741.0112.0068  
 K4-311291431017 6.062.308.0996.0774.0621.0437.0371.0386.0738.0944.1182.1822.2084  
 K4-311291431018 3029.4954.7699.6534.8638.7967.4112.3849.5030.1705.8556.6834.1988  
 K4-311291431021 7.853.741.0808.0471.0447.0497.0548.0548.0608.0722.0916.0896.1562  
 K4-311281431022 1301.2967.2618.2831.3489.3430.1415.0886.0731.0530.1722.1784.0751  
 K4-311291431022 7.852.718.0753.0760.0623.0686.0809.0891.1084.1332.1731.2071.1669  
 K4-311291431024 2070.2262.3928.4544.2465.3632.1766.0468.0910.0569.0343.0080  
 K4-311281431025 7.852.572.0883.0743.0790.0886.0933.1073.1446.1517.1851.1751.2657  
 K4-311281431026 1708.3655.2736.3408.3129.1701.1360.0807.0541.0332.0309.0110.0255  
 K5-112111537011 9.938.806.0504.0366.0398.0461.0519.0706.0768.1059.0969.1238.1062  
 K5-112111537012 1789.3064.2479.2070.1419.2156.2415.2534.1762.0862.0540.0617.0341  
 K5-112111537013 9.936.550.0456.0358.0402.0442.0545.0779.0852.1179.1702.1680.1801  
 K5-112111537014 1676.4551.2408.5154.1541.1542.2283.1451.1489.0566.0370.0303.0193  
 K5-112111537015 9.932.550.0945.1005.1097.1209.1799.1808.2006.2561.2313.2091.2997  
 K5-112111537016 2607.2077.2698.3225.1520.1377.0230.0516.0682.0227.0133.0103.0119  
 K5-112111537017 307.838.0495.0397.0578.0828.1290.2102.4058.5176.6203.7625.8583  
 K5-112111537018 4682.3542.1711.6361.1891.8702.0497.2481.466.7793.4438.6136.3602  
 K5-112111537021 8.957.506.0736.0447.0508.0524.0659.0787.1098.1360.1770.1153.2222  
 K5-112111537022 1995.2551.2997.3005.1130.1740.1721.2988.1387.0865.0510.0671.0493  
 K5-112111537023 8.959.506.0549.0425.0458.0511.0669.0837.1159.1524.2582.2822.2391  
 K5-112111537024 2095.3342.2233.2425.1772.0811.1014.1094.2400.1398.0379.0083.0139  
 K5-112111537025 9.955.500.0222.0734.0866.1035.1295.1611.1849.2573.2644.2433.3224  
 K5-112111537026 2850.2707.2522.2855.1463.1369.0435.0563.0563.0352.0226.0215.0136  
 K5-212111737011 2.6012.95.0467.0477.0503.0719.0788.0918.1156.1634.2000.2306.2067  
 K5-212111737012 2409.2087.2564.2475.2036.2451.1298.0908.0598.2087.0704.0358.0458  
 K5-212111737013 2.6011.10.0732.0564.0571.0716.1016.1136.1617.2027.2859.2391.2897  
 K5-212111737014 4305.2070.3420.1000.1558.0854.0068.0616.0576.0453.0165.0263.0164  
 K5-212111737015 2.604.396.1575.1257.1402.1570.1891.1820.2379.2616.2072.2625.2409  
 K5-212111737016 2795.2045.2712.1794.1474.1215.0742.0352.0457.0231.0362.0260.0068  
 K5-212111737017 2.6012.39.1325.1223.1429.1998.3229.4132.75881.1701.5201.4552.140  
 K5-212111737018 6843.1793.5953.4663.4254.2642.5882.462.74503.0861.225.93991.266  
 K5-212111737021 2.6511.48.0595.0457.0551.0447.0783.0862.1023.1261.1325.1633.1380  
 K5-212111737022 2090.2400.3234.1696.2998.3760.1563.2087.0593.1451.0377.0319.0434  
 K5-212111737023 2.6511.76.0645.0576.0661.0682.0765.1264.1732.2111.2132.3071.2651  
 K5-212111737024 3660.3166.2742.3142.1201.1099.1267.0797.0770.0417.0288.0260.0131  
 K5-212111737025 2.558.8111.018.0876.0918.1097.1370.1717.2049.2325.2217.2631.2670  
 K5-212111737026 2571.2220.3415.2383.1697.0977.0956.0776.0633.0337.0253.0215.0116

SEA-TAC INTENSIVE MEASUREMENT PROGRAM POWER SPECTRA

51-111151125011 4.59,7747,0487,0334,0338,0439,0458,0501,0699,0686,1017,1208,0905  
 51-111151125012 1.767,2101,1422,1662,2347,2565,3780,2173,2469,1208,0386,1782,1557  
 51-111151125013 4.59,0676,0259,0268,0288,0367,0492,0683,0869,0919,0938,0900,1139  
 51-111151125014 1.562,1061,2695,4014,2584,2370, 208,2268,2684,3304,1510,0306,0130  
 51-111151125015 4.59,2219,1625,1169,1267,1368,1931,2225,2691,2824,3195,2322,2191  
 51-111151125016 1.938,2603,1522,1796,1347,0834,0591,0285,0381,0698,0635,0400,0096  
 51-111151125017 4.63,7522,0118,0112,0099,0073,0068,0090,0167,0190,0381,0616,0586  
 51-111151125018 0.969,1614,1062,1585,2387,2251,3574,1564,1950,1187,0439,1324,1185  
 51-111151125021 6.70,8488,0529,0351,0308,0347,0431,0398,0613,0763,0765,0842,1514  
 51-111151125022 2019,1452,3103,2859,1981,2610,5405,2039,1057,0312,0355,0762,0704  
 51-111151125023 4.70,8975,0309,0419,0314,0421,0525,0582,0871,1092,1249,1842,1783  
 51-111151125024 1.610,2014,2684,3691,2714,2426,2902,1883,1859,1561,1036,0491,0318  
 51-111151125025 4.70,2954,0532,0774,0741,0646,0906,1007,1514,1578,2003,2732,2810  
 51-111151125026 2.501,3022,1878,1706,2575,1317,1193,1216,1201,0321,0330,0866,0567  
 51-211151206011 4.941,381,2262,0256,0306,0373,0379,0465,0542,0710,0713,0972,0796  
 51-211151206012 1.292,1239,2584,1585,1240,2249,1057,1948,1946,1645,4410,3666,0900  
 51-211151206013 4.04,8576,0451,0398,0478,0571,0745,1069,1000,1229,1737,1795,1537  
 51-211151206014 2.162,1934,1890,2191,3619,2630,2421,0793,0947,0687,1159,1856,0837  
 51-211151206015 4.46,3041,0796,0690,0873,1224,1608,1952,2919,2523,2621,2894,2409  
 51-211151206016 1.805,2331,1950,1387,1731,1169,0939,0730,0672,0421,0081,0383,0281  
 51-211151206017 4.081,303,0158,0127,0113,0101,0091,0131,0207,0352,0512,0778,0738  
 51-211151206018 1.680,1614,2309,2279,1920,2553,1225,3021,2694,1803,6452,5355,1439  
 51-211151206021 5.221,522,0317,0224,0245,0258,0296,0356,0466,0462,0542,0646,1380  
 51-211151206022 0.728,1200,2961,0835,1638,2591,2761,3483,2269,1378,2272,1737,1795,1537  
 51-211151206023 5.221,032,0441,0366,0393,0607,0687,0814,1017,1517,1417,1949,2310  
 51-211151206024 3.072,2811,1341,1842,4344,1984,2623,0094,1182,1118,0502,0723,0536  
 51-211151206025 5.22,4011,0846,0605,0572,0702,0772,1143,1386,2358,2505,2141,2513  
 51-211151206026 2.298,2174,3185,1099,1507,1712,1065,1463,1270,1273,0257,0065,0068  
 51-211151300011 3.22,3401,0392,0324,0312,0349,0395,0520,0559,0636,1065,0907,1063  
 51-211151300012 0.081,1892,2789,2092,1018,2244,4119,2244,2557,0515,0919,0565,0392  
 51-211151300013 3.22,3287,0334,0287,0305,0394,0534,0862,0910,1181,1236,1605,1425  
 51-211151300014 1.523,2322,1851,2660,2329,1923,2369,0860,1608,3383,3678,1471,1376  
 51-211151300015 2.22,0894,0846,0698,0681,1046,1254,1554,2084,2971,2751,2260,2629  
 51-211151300016 3.263,2711,2001,1408,2223,1156,0867,0481,0532,0536,0658,0369,0317  
 51-211151300017 3.25,4016,0129,0266,0051,0030,0036,0036,0048,0057,0121,0200,0214  
 51-211151300018 0.320,0592,1214,0397,0597,1058,1893,1103,1246,0280,0392,0210,0209  
 51-211151300021 3.45,5387,0351,0297,0281,0298,0311,0340,0495,0605,0595,0925,0840  
 51-211151300022 1.229,2217,2553,2458,1493,4910,2433,1386,3726,1443,1006,1070,0977  
 51-211151300023 3.45,3137,0459,0334,0332,0358,0495,0609,0839,1125,1658,1969,1942  
 51-211151300024 2.045,2736,2685,4242,2200,2612,2156,1536,0681,1339,1147,0650,0329  
 51-211151300025 3.45,1271,0408,0540,0507,0560,0808,0923,1254,1694,1838,1577,3227  
 51-211151300026 2.530,2509,2688,1775,1496,2261,2374,2343,0670,0919,1227,0823,0102

## APPENDIX D

### AVERAGE TURBULENCE INTENSITIES

Appendix D presents the geometric mean turbulence intensities observed in the climatological measurement program. Turbulence intensities are defined as the rms gust velocity divided by the mean longitudinal wind speed. As a result, there are three turbulence intensities of interest for each wind measurement; the intensity of the longitudinal component, the intensity of the lateral component and the intensity of the vertical component. In the compilation of Appendix D, turbulence intensities have not been included when the mean wind speed was less than 0.5 m/s (1.1 mph).

Turbulence intensities are tabulated by site, level of measurement and wind component. Lake Union turbulence intensities are presented first, starting at the lowest level and working upward. For each level the turbulence intensities are presented in the order of longitudinal, lateral and vertical components. The KIXI turbulence intensities follow those from Lake Union, and the SEA-TAC turbulence intensities are presented last.

Within each table in Appendix D, the average intensities for the component are given by speed classes (m/s) and direction classes. In addition, averages for all wind speeds in each direction category and all directions in each wind speed category are given in the margins of the tables.

The number of turbulence intensity observations averaged in each category are given in a separate table following the three turbulence intensity components for a given instrument.

AVERAGE LONGITUDINAL COMPONENT TURBULENCE INTENSITY AT THE LAKE UNION 6.9 m  
LEVEL BY WIND SPEED AND DIRECTION

DIREC.	10FGS.1	<1	1-3	3-5	5-7	7-9	9-11	>11	TOTAL
N		.379	.261	.271	0.000	0.000	0.000	0.000	.281
NNE		.454	.272	.271	.234	0.000	0.000	0.000	.293
NE		.408	.260	.250	0.000	0.000	0.000	0.000	.296
ENE		.370	.251	.174	0.000	0.000	0.000	0.000	.291
E		.448	.363	0.000	0.000	0.000	0.000	0.000	.360
ESE		.393	.349	0.000	0.000	0.000	0.000	0.000	.371
SE		.450	.384	0.000	0.000	0.000	0.000	0.000	.413
SSE		.511	.342	.309	0.000	0.000	0.000	0.000	.411
S		.475	.279	.265	.261	.213	0.000	0.000	.288
SSW		.472	.268	.259	.244	.215	.284	0.000	.269
SW		.422	.275	.239	.198	.213	0.000	0.000	.288
WSW		.387	.277	.249	0.000	0.000	0.000	0.000	.285
W		.380	.269	.177	0.000	0.000	0.000	0.000	.261
WNW		.274	.313	.209	0.000	0.000	0.000	0.000	.283
NW		.411	.200	.142	.107	.108	.121	0.000	.179
NNW		.308	.209	.200	.174	.147	0.000	0.000	.208
		.415	.274	.249	.212	.167	.202	0.000	

AVERAGE LATERAL COMPONENT TURBULENCE INTENSITY AT THE LAKE UNION 6.9 m  
LEVEL BY WIND SPEED AND DIRECTION

DIRN. (DEGS.)	<1	1-3	3-5	5-7	7-9	9-11	>11	TOTAL
N	.250	.180	.152	0.000	0.000	0.000	0.000	.186
NNE	.267	.176	.160	.156	0.000	0.000	0.000	.183
NE	.126	.226	.186	0.000	0.000	0.000	0.000	.247
NNE	.327	.246	.183	0.000	0.000	0.000	0.000	.271
E	.414	.354	0.000	0.000	0.000	0.000	0.000	.393
ESE	.418	.316	0.000	0.000	0.000	0.000	0.000	.327
SE	.452	.400	0.000	0.000	0.000	0.000	0.000	.423
SSE	.417	.328	.273	0.000	0.000	0.000	0.000	.345
S	.121	.244	.218	.198	.214	0.000	0.000	.233
SSW	.455	.231	.274	.224	.245	.243	0.000	.236
SW	.177	.283	.219	.373	.219	0.000	0.000	.283
WSW	.284	.277	.262	0.000	0.000	0.000	0.000	.276
W	.175	.235	.174	0.000	0.000	0.000	0.000	.235
WNW	.168	.247	.145	0.000	0.000	0.000	0.000	.295
NW	.313	.160	.125	.084	.064	.137	0.000	.146
NNW	.344	.152	.116	.099	.109	0.000	0.000	.141
	.347	.224	.188	.164	.139	.190	0.000	

AVERAGE VERTICAL COMPONENT TURBULENCE INTENSITY AT THE LAKE UNION 6.9 m  
LEVEL BY WIND SPEED AND DIRECTION

DIRECTION	<1	1-1	3-5	5-7	7-9	9-11	>11	TOTAL
N	.144	.113	.111	0.000	0.000	0.000	0.000	.119
NNE	.183	.124	.130	.118	0.000	0.000	0.000	.135
NE	.169	.144	.135	0.000	0.000	0.000	0.000	.157
NNE	.140	.155	.116	0.000	0.000	0.000	0.000	.156
E	.220	.224	0.000	0.000	0.000	0.000	0.000	.243
ESE	.203	.242	0.000	0.000	0.000	0.000	0.000	.223
SE	.224	.250	0.000	0.000	0.000	0.000	0.000	.286
SSE	.154	.247	.221	0.000	0.000	0.000	0.000	.261
S	.102	.163	.154	.144	.146	0.000	0.000	.159
SSW	.159	.136	.142	.145	.166	.139	0.000	.142
SW	.166	.154	.138	.150	.157	0.000	0.000	.152
WSW	.173	.182	.159	0.000	0.000	0.000	0.000	.175
W	.174	.141	.117	0.000	0.000	0.000	0.000	.139
WNW	.124	.156	.076	0.000	0.000	0.000	0.000	.134
NW	.144	.075	.060	.041	.036	.060	0.000	.069
NNW	.142	.087	.081	.079	.071	0.000	0.000	.088
	.146	.146	.126	.113	.085	.100	0.000	

NUMBER OF OBSERVATIONS AVERAGED IN THE LAKE UNION 6.9 M LEVEL INTENSITY  
OF TURBULENCE TABLES BY WIND SPEED AND DIRECTION

DIR.	0605.1	41	1-1	3-5	5-7	7-9	9-11	>11	TOTAL
N	29,000	132,000	24,000	0,000	0,000	0,000	0,000	0,000	190,000
NNE	26,000	142,000	37,000	3,000	0,000	0,000	0,000	0,000	228,000
NE	40,000	134,000	17,000	0,000	0,000	0,000	0,000	0,000	200,000
NNE	21,000	39,000	1,000	0,000	0,000	0,000	0,000	0,000	61,000
E	14,000	9,000	0,000	0,000	0,000	0,010	0,000	0,000	25,000
ESE	23,000	24,000	0,000	0,000	0,000	0,000	0,000	0,000	47,000
SE	14,000	18,000	0,000	0,000	0,000	0,000	0,000	0,000	32,000
SSE	21,000	72,000	6,000	0,000	0,000	0,000	0,000	0,000	97,000
S	15,000	143,000	155,000	29,000	2,000	2,000	0,000	0,000	364,000
SSW	17,000	142,000	143,000	29,000	2,000	4,000	2,000	0,000	344,000
SW	23,000	92,000	35,000	1,000	1,000	1,000	0,000	0,000	156,000
WSW	8,000	44,000	11,000	0,000	0,000	0,000	0,000	0,000	68,000
W	5,000	40,000	12,000	0,000	0,000	0,000	0,000	0,000	65,000
WSW	5,000	39,000	7,000	0,000	0,000	0,000	0,000	0,000	31,000
W	9,000	47,000	56,000	12,000	5,000	5,000	2,000	0,000	134,000
WSW	8,000	127,000	71,000	30,000	4,000	4,000	0,000	0,000	240,000
	244,000	1314,000	558,000	104,000	18,000	4,000	4,000	0,000	

AVERAGE LONGITUDINAL COMPONENT TURBULENCE INTENSITY AT THE LAKE UNION 12.6  
+ 17.1 m LEVELS BY WIND SPEED AND DIRECTION

DIRN. (DEGS.)	<1	1-3	3-5	5-7	7-9	9-11	>11	TOTAL
N	.387	.276	.245	.223	.116	0.000	0.000	.283
NNE	.355	.255	.286	.297	0.000	0.000	0.000	.271
NE	.425	.262	.234	0.000	0.000	0.000	0.000	.295
ENE	.400	.259	.223	0.000	0.000	0.000	0.000	.297
E	.409	.354	.315	0.000	0.000	0.000	0.000	.371
ESE	.529	.337	.241	0.000	0.000	0.000	0.000	.374
SE	.437	.462	.424	0.000	0.000	0.000	0.000	.448
SSE	.604	.357	.334	0.000	0.000	0.000	0.000	.391
S	.445	.273	.255	.203	.248	0.000	0.000	.267
SSW	.702	.244	.231	.236	.217	.339	.197	.247
SW	.705	.253	.241	.261	0.000	0.000	0.000	.255
WSW	.441	.272	.215	0.000	0.000	0.000	0.000	.297
W	.295	.279	.152	0.000	0.000	0.000	0.000	.277
WNW	.424	.232	.221	0.000	0.000	0.000	0.000	.255
NW	.748	.220	.134	.114	.136	0.000	0.000	.169
NNW	.433	.207	.174	.154	.138	0.000	0.000	.201
	.410	.273	.230	.211	.191	.339	.197	

AVERAGE LATERAL COMPONENT TURBULENCE INTENSITY AT THE LAKE UNION 12.6  
+ 17.1 m LEVELS BY WIND SPEED AND DIRECTION

DIR.	DIRS.1	<1	1-3	3-5	5-7	7-9	9-11	>11	TOTAL
N	.188	.164	.107	.086	.059	0.000	0.000	0.000	.145
NNE	.241	.168	.134	0.000	0.000	0.000	0.000	0.000	.177
NE	.164	.243	.182	0.000	0.000	0.000	0.000	0.000	.263
ENE	.234	.254	.173	0.000	0.000	0.000	0.000	0.000	.301
E	.209	.360	.216	0.000	0.000	0.000	0.000	0.000	.305
ESE	.410	.279	.191	0.000	0.000	0.000	0.000	0.000	.302
SF	.395	.385	.454	0.000	0.000	0.000	0.000	0.000	.392
SSF	.485	.310	.288	0.000	0.000	0.000	0.000	0.000	.333
S	.272	.226	.190	.184	.201	0.000	0.000	0.000	.210
SSW	.271	.230	.194	.214	.201	.243	0.000	.178	.215
SW	.317	.254	.217	.225	0.000	0.000	0.000	0.000	.254
WSW	.420	.243	.181	0.000	0.000	0.000	0.000	0.000	.261
W	.216	.276	.125	0.000	0.000	0.000	0.000	0.000	.259
WSW	.455	.283	.154	0.000	0.000	0.000	0.000	0.000	.288
NW	.177	.176	.120	.086	.109	0.000	0.000	0.000	.137
WNW	.340	.145	.127	.126	.127	0.000	0.000	0.000	.148
	.322	.221	.174	.168	.161	.243	0.000	.178	

AVERAGE VERTICAL COMPONENT TURBULENCE INTENSITY AT THE LAKE UNION 12.6  
±17.1 m LEVELS BY WIND SPEED AND DIRECTION

DIRN. (DEGS.)	<1	1-3	3-5	5-7	7-9	9-11	>11	TOTAL
N	.187	.150	.120	.092	.077	0.000	0.000	.148
NNE	.242	.164	.153	.137	0.000	0.000	0.000	.172
NE	.245	.191	.165	0.000	0.000	0.000	0.000	.200
NNE	.117	.142	.137	0.000	0.000	0.000	0.000	.217
E	.272	.304	.220	0.000	0.000	0.000	0.000	.290
ESE	.326	.246	.197	0.000	0.000	0.000	0.000	.261
SE	.354	.374	.415	0.000	0.000	0.000	0.000	.365
SSE	.477	.206	.254	0.000	0.000	0.000	0.000	.311
S	.242	.199	.174	.155	.159	0.000	0.000	.183
SSW	.172	.182	.159	.159	.158	.188	.131	.168
SW	.241	.192	.159	.127	0.000	0.000	0.000	.188
WSW	.306	.209	.146	0.000	0.000	0.000	0.000	.213
W	.248	.212	.195	0.000	0.000	0.000	0.000	.214
WNW	.225	.156	.128	0.000	0.000	0.000	0.000	.167
W	.145	.126	.091	.060	.056	0.000	0.000	.099
WSW	.324	.112	.088	.084	.080	0.000	0.000	.112
W	.270	.188	.150	.131	.121	.188	.131	.131

NUMBER OF OBSERVATIONS AVERAGED IN THE LAKE UNION 12.6 + 17.1 m LEVELS  
INTENSITY OF TURBULENCE TABLES BY WIND SPEED AND DIRECTION

DIR. (DEGS.)	<1	1-3	3-5	5-7	7-9	9-11	>11	TOTAL
N	29,000	153,000	28,000	8,000	2,010	0,000	0,000	220,000
NNE	72,000	142,000	36,000	3,000	0,010	0,000	0,000	203,000
NE	37,000	110,000	19,000	0,000	0,010	0,000	0,000	166,000
NNE	17,000	31,000	2,000	0,000	0,010	0,000	0,000	46,000
E	9,000	17,000	1,000	0,000	0,010	0,000	0,000	27,000
ESE	9,000	27,000	3,000	0,000	0,010	0,000	0,000	39,000
SE	24,000	22,000	1,000	0,000	0,010	0,000	0,000	47,000
SSE	14,000	73,000	10,000	0,000	0,010	0,000	0,000	97,000
S	11,000	171,000	142,000	61,000	7,010	0,000	0,000	392,000
SSW	11,000	123,000	151,000	41,000	7,000	1,000	1,000	335,000
SW	10,000	60,000	31,000	4,000	0,010	0,000	0,000	134,000
WSW	14,000	48,000	17,000	0,000	0,010	0,000	0,000	79,000
W	0,000	30,000	2,000	0,000	0,010	0,000	0,000	46,000
WNW	7,000	12,000	2,000	0,000	0,000	0,000	0,000	16,000
W	9,000	32,000	54,000	12,000	4,000	0,000	0,000	111,000
WNW	10,000	81,000	45,000	31,000	4,000	0,000	0,000	171,000
W	236,000	1143,000	564,000	160,000	26,010	1,000	1,000	

AVERAGE LONGITUDINAL COMPONENT TURBULENCE INTENSITY AT THE LAKE UNION 24.8 m  
LEVEL BY WIND SPEED AND DIRECTION

DIRN. (REGS.)	<1	1-3	3-5	5-7	7-9	9-11	>11	TOTAL
N	.175	.265	.176	.175	0.000	0.000	0.000	.240
NNE	.175	.215	.216	.127	.261	0.000	0.000	.233
NE	.175	.236	.186	.189	0.000	0.000	0.000	.235
ENE	.143	.257	.180	.271	0.000	0.000	0.000	.270
E	.116	.340	.155	.192	0.000	0.000	0.000	.345
ESE	.116	.266	.228	.109	0.000	0.000	0.000	.277
SF	.531	.342	.234	0.000	0.000	0.000	0.000	.392
SSE	.168	.347	.266	.234	0.000	0.000	0.000	.339
S	.167	.268	.233	.217	.223	.192	0.000	.241
SSW	.512	.268	.220	.221	.212	.217	.282	.241
SW	.119	.263	.215	.222	0.000	0.000	0.000	.271
WSW	.169	.243	.196	.332	0.000	0.000	0.000	.261
W	.149	.310	0.000	0.000	0.000	0.000	0.000	.348
WNW	.554	.254	.136	0.000	0.000	0.000	0.000	.293
WV	.167	.169	.165	.684	0.000	0.000	0.000	.183
WNW	.100	.174	.124	.125	.136	.043	0.000	.151
WNW	.172	.267	.204	.188	.204	.175	.282	.282

AVERAGE LATERAL COMPONENT TURBULENCE INTENSITY AT THE LAKE UNION 24.8 m  
LEVEL BY WIND SPEED AND DIRECTION

DIR.	(DEGS.)	0-1	1-3	3-5	5-7	7-9	9-11	>11	TOTAL
N	.188	.143	.117	.114	0.300	0.300	0.000	0.000	.138
NNE	.148	.166	.150	.096	.170	0.000	0.000	0.000	.178
NE	.328	.204	.148	.140	0.300	0.300	0.000	0.000	.200
NNE	.199	.245	.169	.264	0.300	0.300	0.000	0.000	.304
E	.408	.249	.207	.138	0.300	0.300	0.000	0.000	.298
ESE	.121	.262	.181	.070	0.300	0.300	0.000	0.000	.237
SE	.197	.303	.182	0.000	0.300	0.300	0.000	0.000	.298
SSE	.514	.243	.218	.175	0.300	0.300	0.000	0.000	.273
S	.270	.203	.177	.165	.157	.157	.172	0.000	.163
SSW	.409	.254	.174	.162	.173	.169	.169	.189	.203
SW	.183	.254	.193	.205	0.300	0.300	0.000	0.000	.259
WSW	.144	.240	.162	.175	0.300	0.300	0.000	0.000	.243
W	.113	.121	0.000	0.000	0.300	0.300	0.000	0.000	.319
WNW	.177	.287	.104	0.000	0.300	0.300	0.000	0.000	.279
W	.415	.113	.122	.046	0.300	0.300	0.000	0.000	.142
WNW	.275	.156	.117	.104	.103	.078	.078	0.000	.133
W	.142	.219	.161	.145	.154	.152	.152	.189	

AVERAGE VERTICAL COMPONENT TURBULENCE INTENSITY AT THE LAKE UNION 24.8 m  
LEVEL BY WIND SPEED AND DIRECTION

DIR. (DEGS.)	<1	1-3	3-5	5-7	7-9	9-11	>11	TOTAL
N	.182	.147	.119	.094	0.000	0.000	0.000	.137
NNE	.271	.166	.159	.118	.170	0.000	0.000	.172
NE	.250	.182	.141	.144	0.000	0.000	0.000	.176
ENE	.058	.216	.135	.172	0.000	0.000	0.000	.220
E	.438	.256	.175	.165	0.000	0.000	0.000	.258
ESE	.152	.275	.162	.070	0.000	0.000	0.000	.217
SE	.193	.247	.209	0.000	0.000	0.000	0.000	.299
SSE	.530	.247	.188	.178	0.000	0.000	0.000	.259
S	.266	.192	.169	.152	.145	.148	0.000	.171
SSW	.116	.207	.160	.158	.158	.154	.173	.177
SW	.173	.268	.159	.149	0.000	0.000	0.000	.216
WSW	.261	.255	.148	.144	0.000	0.000	0.000	.202
W	.172	.237	0.000	0.000	0.000	0.000	0.000	.260
WNW	.148	.221	.122	0.000	0.000	0.000	0.000	.232
NW	.297	.136	.111	.046	0.000	0.000	0.000	.118
NNW	.277	.128	.092	.079	.080	.053	0.000	.108
	.101	.195	.149	.128	.139	.132	.173	

NUMBER OF OBSERVATIONS AVERAGED IN THE LAKE UNION 24.8 m LEVEL INTENSITY  
OF TURBULENCE TABLES BY WIND SPEED AND DIRECTION

DIR. (DEGS.)	<1	1-3	3-5	5-7	7-9	9-11	>11	TOTAL
N	21,000	117,000	60,000	15,000	0,000	0,000	0,000	211,000
NNE	21,000	157,000	56,000	3,000	1,000	0,000	0,000	235,000
NE	21,000	127,000	57,000	5,300	0,000	0,000	0,000	208,000
ENE	12,000	51,000	14,000	2,000	0,000	0,000	0,000	61,000
E	6,000	14,000	4,000	1,000	0,000	0,000	0,000	33,000
ESE	4,000	17,000	4,000	3,000	0,000	0,000	0,000	26,000
SE	11,000	42,000	10,000	0,000	0,000	0,000	0,000	63,000
SSE	7,000	101,000	35,000	5,000	0,100	0,000	0,000	151,000
S	9,000	111,000	162,000	83,000	27,000	3,000	0,000	392,000
SSW	8,000	97,000	148,000	59,000	21,000	5,000	1,000	337,000
SW	14,000	79,000	33,000	4,000	0,000	0,000	0,000	134,000
WSW	11,000	35,000	14,000	1,000	0,000	0,000	0,000	61,000
W	6,000	19,000	0,000	0,000	0,000	0,000	0,000	25,000
WNW	3,000	12,000	2,000	0,000	0,000	0,000	0,000	17,000
WW	4,000	27,000	34,000	21,000	0,000	0,000	0,000	89,000
WNW	4,000	47,000	76,000	36,000	10,000	2,000	0,000	197,000
TOTAL	174,000	1673,000	716,000	238,000	56,000	10,000	1,000	

AVERAGE LONGITUDINAL COMPONENT TURBULENCE INTENSITY AT THE LAKE UNION 48.2 m  
LEVEL BY WIND SPEED AND DIRECTION

DIRN.	(DEGS.)	<	1-1	3-5	5-7	7-9	9-11	>11	TOTAL
N		.075	.194	.168	.148	.186	0.000	0.000	.196
NNE		.136	.204	.178	.121	0.000	0.000	0.000	.200
NE		.534	.232	.167	.138	0.000	0.000	0.000	.222
ENE		.280	.261	.180	.185	0.000	0.000	0.000	.236
E		.322	.404	.134	.274	0.110	0.000	0.000	.374
ESE		.636	.298	0.000	0.000	.125	0.000	.305	.327
SF		.505	.159	.141	.143	0.110	0.000	.087	.307
SSE		.471	.322	.234	.300	.114	0.000	.255	.301
S		.240	.253	.170	.204	.230	.196	.206	.202
SSW		.420	.243	.124	.184	.184	.200	.175	.207
SW		.281	.225	.174	.186	.199	0.000	0.000	.206
WSW		.416	.214	.168	.165	0.300	0.000	0.000	.216
W		.434	.251	0.000	0.000	0.300	0.000	0.000	.318
WSW		.415	.221	.230	0.000	0.300	0.000	0.000	.314
WNW		.400	.152	.115	.160	0.300	0.000	0.000	.177
WNW		.474	.171	.119	.124	.106	.170	0.000	.149
W		.442	.228	.167	.182	.187	.196	.198	.198

AVERAGE LATERAL COMPONENT TURBULENCE INTENSITY AT THE LAKE UNION 48.2 m  
LEVEL BY WIND SPEED AND DIRECTION

DIR. (DGS.)	CI	1-3	3-5	5-7	7-9	9-11	>11	TOTAL
N	.117	.150	.125	.109	.123	0.000	0.000	.146
NNE	.275	.197	.131	.071	0.000	0.000	0.000	.156
NE	.184	.194	.147	.118	0.000	0.000	0.000	.181
NNE	.442	.288	.164	.170	0.000	0.000	0.000	.276
E	.172	.327	.132	.109	0.000	0.000	0.000	.336
ESE	.447	.267	0.000	0.000	.040	0.000	.479	.301
SE	.430	.209	.044	.121	0.000	0.000	.049	.212
SSE	1.211	.259	.174	.193	.125	0.000	.077	.244
S	.407	.242	.168	.136	.121	.108	.149	.148
SSW	.233	.234	.150	.154	.161	.144	.180	.172
SW	.264	.236	.175	.164	.156	0.000	0.000	.190
WSW	.419	.214	.140	.159	0.010	0.000	0.000	.208
W	.209	.217	0.000	0.000	0.000	0.000	0.000	.259
WNW	.440	.241	.213	0.000	0.000	0.000	0.000	.381
W	.416	.134	.110	.111	0.000	0.000	0.000	.141
WNW	.141	.141	.100	.113	.083	.143	0.000	.131
WSW	.104	.124	.142	.138	.128	.119	.161	.161

AVERAGE VERTICAL COMPONENT TURBULENCE INTENSITY AT THE LAKE UNION 48.2 M  
LEVEL BY WIND SPEED AND DIRECTION

Dir.	1-3	3-5	5-7	7-9	9-11	>11	TOTAL
N	.031	.070	.075	.060	0.000	0.000	.099
NNE	.114	.094	.082	0.000	0.000	0.000	.110
NE	.100	.107	.112	0.000	0.000	0.000	.135
NNE	.105	.111	.121	0.000	0.000	0.000	.172
E	.020	.099	.134	0.130	0.000	0.000	.222
ESE	.001	0.000	0.000	.110	0.000	.050	.161
SE	.240	.137	.115	0.000	0.000	.043	.211
SSE	.070	.130	.114	.117	0.000	.094	.174
S	.151	.105	.094	.085	.068	.120	.099
SSW	.107	.114	.101	.08	.105	.102	.117
SW	.277	.117	.110	.086	0.000	0.000	.134
WSW	.060	.110	.105	0.000	0.000	0.000	.145
W	.141	0.000	0.000	0.100	0.000	0.000	.210
WNW	.253	.153	0.000	0.000	0.000	0.000	.201
W	.050	.060	.073	0.000	0.000	0.000	.098
WNW	.200	.055	.068	.057	.101	0.000	.081
W	.240	.097	.093	.089	.093	.092	.092

NUMBER OF OBSERVATIONS AVERAGED IN THE LAKE UNION 48.4 m LEVEL INTENSITY  
OF TURBULENCE TABLES BY WIND SPEED AND DIRECTION

DIRN. (GERS.)	<1	1-1	1-5	5-7	7-9	9-11	>11	TOTAL
N	0.000	40.000	39.000	21.000	2.000	0.000	0.000	156.000
NNE	5.000	57.000	29.000	6.000	0.000	0.000	0.000	95.000
NE	7.000	50.000	44.000	6.000	0.000	0.000	0.000	105.000
ESE	5.000	22.000	13.000	1.000	0.000	0.000	0.000	43.000
E	1.000	11.000	1.000	1.000	0.100	0.000	0.000	14.000
ENE	1.000	1.000	0.000	0.000	1.000	0.000	1.000	6.000
SE	4.000	10.000	7.000	1.000	0.000	0.000	1.000	23.000
SSE	3.000	24.000	27.000	5.000	5.000	0.000	1.000	62.000
S	6.000	14.000	57.000	105.000	54.000	18.000	2.000	251.000
SSW	5.000	17.000	83.000	75.000	19.000	7.000	3.000	225.000
SW	6.000	67.000	30.000	16.000	3.000	0.000	0.000	129.000
WSW	5.000	30.000	17.000	2.000	0.000	0.000	0.000	62.000
W	10.000	10.000	0.000	0.000	0.000	0.000	0.000	20.000
WNW	6.000	6.000	1.000	0.000	0.000	0.000	0.000	13.000
NW	5.000	20.000	28.000	11.000	0.000	0.000	0.000	70.000
NNW	6.000	64.000	75.000	35.000	9.000	1.000	0.000	190.000
	41.000	574.000	955.000	286.000	92.100	26.000	6.000	

AVERAGE LONGITUDINAL COMPONENT TURBULENCE INTENSITY AT THE KIXI 77.1 m  
LEVEL BY WIND SPEED AND DIRECTION

DIRN. (DEGS.)	<1	1-3	3-5	5-7	7-9	9-11	>11	TOTAL
N	.585	.214	.152	.156	.128	.098	0.000	.203
NNE	.642	.281	.176	.152	.140	0.000	0.000	.225
NE	.542	.315	.201	.166	.260	0.000	0.000	.262
ENE	.722	.329	.182	.258	.052	0.000	0.000	.303
E	.523	.301	.171	.095	0.000	0.000	0.000	.315
ESE	.609	.315	.350	.253	0.000	0.000	0.000	.391
SE	.780	.239	.190	.227	.217	0.000	0.000	.223
SSE	0.000	.291	.197	.205	.180	.192	0.000	.219
S	.752	.364	.267	.265	.250	.284	0.000	.306
SSW	.700	.355	.291	.321	.287	0.000	0.000	.326
SW	.751	.387	.283	.252	.211	.126	.277	.357
WSW	.327	.373	.266	0.000	0.000	0.000	0.000	.432
W	.800	.356	.206	0.000	0.000	0.000	0.000	.450
WNW	.538	.431	.174	0.000	0.000	0.000	0.000	.444
NW	.808	.347	.202	.177	.164	0.000	0.000	.262
NNW	.799	.381	.247	.199	.180	.128	0.000	.252
W	.700	.314	.219	.211	.203	.160	.277	

AVERAGE LATERAL COMPONENT TURBULENCE INTENSITY AT THE KIXI 77.1 m LEVEL  
BY WIND SPEED AND DIRECTION

DIFA. (DEGS.)	<1	1-3	3-5	5-7	7-9	9-11	>11	TOTAL
N	.162	.133	.122	.115	.110	.126	0.000	.128
NNE	.239	.226	.135	.115	.134	0.000	0.000	.174
NE	.561	.281	.179	.134	.195	0.000	0.000	.236
ENE	.569	.250	.151	.171	.048	0.000	0.000	.234
E	.108	.154	.135	.084	0.000	0.000	0.000	.137
ESE	.469	.347	.277	.199	0.000	0.000	0.000	.333
SE	.586	.213	.178	.192	.154	0.000	0.000	.197
SSE	0.000	.221	.171	.176	.173	.168	0.000	.183
S	.553	.362	.277	.263	.237	.280	0.000	.293
SSW	.691	.322	.297	.287	.374	0.000	0.000	.313
SW	.616	.309	.227	.204	.190	.112	.207	.288
WSW	.566	.315	.226	0.000	0.000	0.000	0.000	.343
W	.298	.221	.221	0.000	0.000	0.000	0.000	.238
WNW	.638	.375	.185	0.000	0.000	0.000	0.000	.412
NW	.628	.279	.224	.142	.107	0.000	0.000	.224
NNW	.734	.263	.192	.145	.128	.119	0.000	.186
NN	.403	.245	.194	.175	.176	.179	.207	.207

AVERAGE VERTICAL COMPONENT TURBULENCE INTENSITY AT THE KIXI 77.1 m LEVEL  
BY WIND SPEED AND DIRECTION

DIRN. (DEGS.)	<1	1-3	3-5	5-7	7-9	9-11	>11	TOTAL
N	.190	.101	.067	.059	.065	.046	0.000	.087
NNE	.098	.115	.074	.063	.083	0.000	0.000	.091
NE	.205	.127	.096	.092	.121	0.000	0.000	.114
ENE	.272	.153	.070	.087	.021	0.000	0.000	.124
E	.220	.177	.084	.053	0.000	0.000	0.000	.162
ESE	.345	.182	.134	.118	0.000	0.000	0.000	.188
SE	.286	.128	.114	.101	.092	0.000	0.000	.118
SSE	0.000	.147	.108	.119	.124	.168	0.000	.120
S	.335	.200	.145	.163	.158	.185	0.000	.168
SSW	.283	.197	.165	.146	.167	0.000	0.000	.176
SW	.353	.197	.129	.098	.106	.079	.153	.170
WSW	.297	.188	.129	0.000	0.000	0.000	0.000	.198
W	.442	.194	.165	0.000	0.000	0.000	0.000	.247
WNW	.476	.209	.080	0.000	0.000	0.000	0.000	.251
NW	.658	.155	.120	.089	.079	0.000	0.000	.143
NNW	.261	.163	.093	.081	.063	.087	0.000	.100
	.307	.156	.108	.101	.108	.119	.153	

NUMBER OF OBSERVATIONS AVERAGED IN THE KIXI 77.1 m LEVEL INTENSITY  
OF TURBULENCE TABLES BY WIND SPEED AND DIRECTION

DIRN. (DEGS.)	<1	1-3	3-5	5-7	7-9	9-11	>11	TOTAL
N	15,000	99,000	94,000	31,000	7,000	2,000	0,000	248,000
NNE	2,000	68,000	60,000	21,000	2,000	0,000	0,000	153,000
NE	4,000	33,000	31,000	10,000	1,000	0,000	0,000	79,000
ENE	5,000	16,000	17,000	5,000	1,000	0,000	0,000	44,000
E	10,000	24,000	9,000	2,000	0,000	0,000	0,000	45,000
ESE	3,000	10,000	5,000	2,000	0,000	0,000	0,000	20,000
SE	1,000	31,000	31,000	13,000	5,000	0,000	0,000	81,000
SSE	0,000	38,000	90,000	45,000	5,000	1,000	0,000	179,000
S	4,000	29,000	56,000	24,000	25,000	3,000	0,000	141,000
SSW	3,000	53,000	74,000	18,000	1,000	0,000	0,000	149,000
SW	11,000	40,000	40,000	13,000	6,000	1,000	1,000	112,000
WSW	11,000	50,000	9,000	0,000	0,000	0,000	0,000	70,000
W	17,000	61,000	1,000	0,000	0,000	0,000	0,000	79,000
WNW	3,000	12,000	1,000	0,000	0,000	0,000	0,000	16,000
W	1,000	6,000	6,000	6,000	2,000	0,000	0,000	21,000
NNW	1,000	22,000	33,000	32,000	18,000	2,000	0,000	108,000
	91,000	592,000	557,000	222,000	73,000	9,000	1,000	

AVERAGE LONGITUDINAL COMPONENT TURBULENCE INTENSITY AT THE KIXI 95.4 m  
LEVEL BY WIND SPEED AND DIRECTION

DIRN. (DEGS.)	<1	1-3	3-5	5-7	7-9	9-11	>11	TOTAL
N	.310	.170	.120	.116	.104	.064	0.000	.147
NNE	.366	.208	.187	.151	0.000	0.000	0.000	.206
NE	.490	.226	.175	.176	0.000	0.000	0.000	.215
ENE	.403	.184	.203	.165	0.000	0.000	0.000	.228
E	.474	.283	.184	.080	0.000	0.000	0.000	.282
ESE	.432	.272	.329	.306	0.000	0.000	0.000	.309
SE	.699	.213	.173	.197	.170	0.000	0.000	.200
SSE	.389	.237	.191	.192	.254	0.000	0.000	.207
S	.442	.322	.277	.261	.249	0.000	.235	.296
SSW	.292	.292	.276	.290	.235	.269	.254	.283
SW	.550	.296	.255	.191	.092	0.000	0.000	.322
WSW	.569	.349	.171	0.000	0.000	0.000	0.000	.361
W	.402	.284	0.000	0.000	0.000	0.000	0.000	.304
WNW	.360	.314	.211	0.000	0.000	0.000	0.000	.319
NW	.654	.285	.191	.165	.109	0.000	0.000	.262
NNW	.503	.278	.200	.159	.144	0.000	0.000	.218
	.643	.258	.205	.193	.180	.167	.245	

AVERAGE LATERAL COMPONENT TURBULENCE INTENSITY AT THE KIXI 95.4 m LEVEL  
BY WIND SPEED AND DIRECTION

DIRN. (DEGS.)	<1	1-3	3-5	5-7	7-9	9-11	>11	TOTAL
N	.159	.122	.092	.090	.098	.054	0.000	.107
NNE	.230	.161	.117	.107	0.000	0.000	0.000	.147
NE	.070	.212	.146	.149	0.000	0.000	0.000	.194
ENE	.308	.167	.161	.116	0.000	0.000	0.000	.197
E	.511	.221	.160	.071	0.000	0.000	0.000	.252
ESE	.353	.302	.237	.231	0.000	0.000	0.000	.291
SE	.485	.190	.146	.147	.136	0.000	0.000	.168
SSE	.292	.196	.159	.161	.152	0.000	0.000	.170
S	.360	.305	.242	.241	.236	0.000	.204	.268
SSW	.262	.256	.255	.258	.214	.221	.189	.254
SW	.540	.252	.218	.203	.116	0.000	0.000	.282
WSW	.440	.304	.160	0.000	0.000	0.000	0.000	.308
W	.283	.294	0.000	0.000	0.000	0.000	0.000	.292
WNW	.358	.291	.167	0.000	0.000	0.000	0.000	.300
NW	.384	.250	.192	.135	.078	0.000	0.000	.229
NNW	.353	.225	.157	.117	.107	0.000	0.000	.168
	.356	.225	.171	.162	.149	.138	.197	

AVERAGE VERTICAL COMPONENT TURBULENCE INTENSITY AT THE KIXI 95.4 m LEVEL  
BY WIND SPEED AND DIRECTION

DIRN.	(DEGS.)	1-1	1-3	3-5	5-7	7-9	9-11	>11	TOTAL
N	.217	.144	.109	.100	.088	.063	0.000	0.000	.128
NNE	.230	.148	.131	.122	0.000	0.000	0.000	0.000	.145
NE	.388	.213	.138	.124	0.000	0.000	0.000	0.000	.186
ENE	.255	.151	.128	.105	0.000	0.000	0.000	0.000	.153
E	.611	.252	.139	.074	0.000	0.000	0.000	0.000	.280
ESE	.495	.274	.221	.195	0.000	0.000	0.000	0.000	.288
SE	.416	.171	.135	.126	.132	0.000	0.000	0.000	.152
SSE	.337	.215	.155	.149	.174	0.000	0.000	0.000	.171
S	.455	.302	.218	.196	.184	0.000	0.000	.194	.252
SSW	.300	.289	.232	.203	.187	.167	.174	.174	.246
SW	.702	.322	.209	.164	.105	0.000	0.000	0.000	.348
WSW	.755	.400	.157	0.000	0.000	0.000	0.000	0.000	.424
W	.341	.250	0.000	0.000	0.000	0.000	0.000	0.000	.348
WNW	.267	.345	.134	0.000	0.000	0.000	0.000	0.000	.319
NW	.553	.257	.193	.131	.091	0.000	0.000	0.000	.267
NNW	.413	.238	.169	.126	.111	0.000	0.000	0.000	.181
	.441	.249	.166	.146	.137	.115	.184	.184	

NUMBER OF OBSERVATIONS AVERAGED IN THE KIXI 95.4 m LEVEL INTENSITY  
OF TURBULENCE TABLES BY WIND SPEED AND DIRECTION

DIRN. (DEGS.)	<1	1-3	3-5	5-7	7-9	9-11	>11	TOTAL
N	11,000	94,000	88,000	36,000	4,000	2,000	0,000	235,000
NNE	7,000	72,000	41,000	9,000	0,000	0,000	0,000	129,000
NE	3,000	32,000	23,000	6,000	0,000	0,000	0,000	64,000
ENE	5,000	7,000	12,000	4,000	0,000	0,000	0,000	28,000
E	4,000	10,000	6,000	1,000	0,000	0,000	0,000	21,000
ESE	3,000	13,000	5,000	1,000	0,000	0,000	0,000	22,000
SE	1,000	33,000	26,000	10,000	8,000	0,000	0,000	78,000
SSE	3,000	36,000	84,000	32,000	4,000	0,000	0,000	159,000
S	11,000	62,000	78,000	32,000	12,000	0,000	1,000	196,000
SSW	5,000	48,000	67,000	24,000	3,000	2,000	1,000	150,000
SW	10,000	40,000	15,000	3,000	1,000	0,000	0,000	69,000
WSW	11,000	61,000	8,000	0,000	0,000	0,000	0,000	80,000
W	7,000	36,000	0,000	0,000	0,000	0,000	0,000	43,000
WNW	5,000	17,000	1,000	0,000	0,000	0,000	0,000	23,000
NW	7,000	8,000	7,000	9,000	1,000	0,000	0,000	32,000
NNW	7,000	31,000	44,000	26,000	21,000	0,000	0,000	129,000
	100,000	600,000	505,000	193,000	54,000	4,000	2,000	

AVERAGE LONGITUDINAL COMPONENT TURBULENCE INTENSITY AT SEA-TAC 7.1 m LEVEL  
BY WIND SPEED AND DIRECTION

DIR. (DEGS.)	<1	1-3	3-5	5-7	7-9	9-11	>11	TOTAL
N	.296	.229	.244	.182	0.300	0.000	0.000	.241
NNE	.267	.230	.207	.195	.133	0.000	0.000	.219
NE	.420	.167	.173	.175	.146	.107	0.000	.189
NNE	.434	.185	.156	0.000	0.000	0.000	0.000	.224
E	.326	.162	.177	0.000	0.100	0.000	0.000	.191
ESE	.290	.147	.148	.170	.160	0.000	0.000	.157
SE	.145	.152	.134	.163	.170	0.000	0.000	.155
SSE	.197	.161	.161	.177	0.110	0.000	0.000	.166
S	.275	.201	.193	.201	.183	.220	.195	.206
SSW	.266	.236	.203	.212	.110	0.000	0.000	.221
SW	.356	.258	.218	.222	.202	0.000	.104	.240
WSW	.390	.280	.232	.246	.209	0.000	0.000	.281
W	.367	.280	.237	.156	0.000	0.000	0.000	.279
WNW	.576	.313	.241	0.000	0.000	0.000	0.000	.314
W	.510	.313	.283	.126	.141	0.000	0.000	.318
NNW	.213	.262	.277	.264	.217	0.000	0.000	.255
TOTAL	.302	.221	.208	.202	.191	.164	.165	

AVERAGE LATERAL COMPONENT TURBULENCE INTENSITY AT SEA-TAC 7.1 m LEVEL  
BY WIND SPEED AND DIRECTION

DIRN. (DEGS.)	<1	1-3	3-5	5-7	7-9	9-11	>11	TOTAL
N	.250	.190	.235	.389	0.000	0.000	0.000	.214
NNE	.171	.183	.159	.153	.692	0.000	0.000	.169
NE	.327	.142	.137	.128	.120	.072	0.000	.152
ENE	.297	.154	.131	0.000	0.000	0.000	0.000	.174
E	.206	.143	.134	0.000	0.000	0.000	0.000	.151
ESE	.165	.120	.098	.103	.120	0.000	0.000	.119
SE	.168	.129	.102	.139	.133	0.000	0.000	.131
SSE	.177	.146	.141	.168	0.000	0.000	0.000	.150
S	.180	.183	.172	.180	.167	.182	.200	.179
SSW	.267	.217	.260	.186	.187	0.000	0.000	.205
SW	.285	.233	.193	.197	.194	0.000	.083	.214
WSW	.106	.256	.202	.178	.14	0.000	0.000	.248
W	.278	.260	.210	.073	0.000	0.000	0.000	.252
WNW	.342	.293	.220	0.000	0.000	0.000	0.000	.277
NW	.379	.271	.246	.127	.148	0.000	0.000	.265
NNW	.172	.221	.287	.407	.386	0.000	0.000	.227
	.228	.195	.164	.181	.179	.130	.161	

AVERAGE VERTICAL COMPONENT TURBULENCE INTENSITY AT SEA-TAC 7.1 m LEVEL  
BY WIND SPEED AND DIRECTION

DIR. (DEGS.)	<1	1-3	3-5	5-7	7-9	9-11	>11	TOTAL
N	.117	.123	.140	.231	0.000	0.000	0.000	.129
NNE	.113	.098	.105	.099	.076	0.000	0.000	.102
NE	.085	.062	.084	.084	.085	.254	0.000	.078
ENE	.121	.070	.081	0.000	0.000	0.000	0.000	.082
E	.131	.040	.074	0.000	0.000	0.000	0.000	.067
ESE	.035	.049	.051	.072	.053	0.000	0.000	.051
SE	.059	.056	.065	.142	.072	0.000	0.000	.060
SSE	.054	.067	.078	.086	0.000	0.000	0.000	.068
S	.071	.094	.096	.100	.077	.095	.101	.093
SSW	.148	.120	.116	.110	.138	0.000	0.000	.117
SW	.144	.134	.116	.116	.158	0.000	.238	.126
WSW	.140	.152	.138	.124	.161	0.000	0.000	.147
W	.222	.157	.124	0.000	0.000	0.000	0.000	.156
WNW	.144	.150	.130	0.000	0.000	0.000	0.000	.144
NW	.215	.151	.159	.345	.291	0.000	0.000	.167
NNW	.073	.129	.176	.347	.340	0.000	0.000	.132
	.106	.104	.110	.113	.125	.175	.146	

NUMBER OF OBSERVATIONS AVERAGED IN SEA-TAC 7.1 m LEVEL INTENSITY OF  
TURBULENCE TABLES BY WIND SPEED AND DIRECTION

DIRN. (DEGS.)	<1	1-3	3-5	5-7	7-9	9-11	>11	TOTAL
N	26,000	119,000	52,000	5,000	6,000	0,000	0,000	202,000
NNE	10,000	75,000	79,000	13,000	1,000	0,000	0,000	178,000
NE	7,000	39,000	29,000	6,000	1,000	2,000	0,000	86,000
NNE	6,000	26,000	10,000	0,000	0,000	0,000	0,000	44,000
E	9,000	16,000	13,000	0,000	0,000	0,000	0,000	56,000
ESE	6,000	65,000	14,000	12,000	3,000	0,000	0,000	120,000
SE	17,000	88,000	16,000	4,000	1,000	0,000	0,000	126,000
SSE	22,000	123,000	33,000	7,000	0,000	0,000	0,000	187,000
S	32,000	135,000	63,000	30,000	7,000	2,000	2,000	291,000
SSW	10,000	116,000	129,000	69,000	15,000	0,000	0,000	319,000
SW	12,000	110,000	97,000	36,000	10,000	0,000	1,000	266,000
WSW	11,000	55,000	21,000	2,000	1,000	0,000	0,000	90,000
W	6,000	59,000	13,000	1,000	0,000	0,000	0,000	81,000
WNW	7,000	57,000	24,000	0,000	0,000	0,000	0,000	88,000
NW	9,000	61,000	15,000	2,000	3,000	0,000	0,000	90,000
NNW	19,000	69,000	16,000	2,000	1,000	0,000	0,000	107,000
	213,000	1255,000	644,000	171,000	43,000	4,000	3,000	

AVERAGE LONGITUDINAL COMPONENT TURBULENCE INTENSITY AT SEA-TAC 27.0 m  
LEVEL BY WIND SPEED AND DIRECTION

DIRN. (DEGS.)	<1	1-3	3-5	5-7	7-9	9-11	>11	TOTAL
N	.234	.176	.184	.166	.426	0.000	0.000	.182
NNE	.336	.198	.162	.140	.129	0.000	0.000	.174
NE	.303	.125	.117	.129	.103	.094	.078	.128
ENE	.193	.142	.128	.104	0.000	0.000	0.000	.136
E	.234	.154	.126	.116	0.000	0.000	0.000	.160
ESE	.145	.144	.125	.125	.115	.111	0.000	.136
SE	.264	.126	.112	.114	.25	0.000	0.000	.134
SSE	.315	.142	.140	.180	.49	0.000	0.000	.150
S	.242	.175	.185	.183	.205	.176	.201	.184
SSW	.270	.198	.200	.202	.202	.199	0.000	.200
SW	.317	.204	.198	.195	.195	.211	.124	.203
WSW	.516	.232	.212	.222	.305	0.000	0.000	.240
W	.173	.221	.150	.080	0.100	0.000	0.000	.208
WNW	.306	.210	.187	.300	0.100	0.000	0.000	.212
NW	.213	.242	.205	.213	.147	.122	0.000	.223
NNW	.159	.165	.199	.212	.234	.072	0.000	.191
	.270	.179	.179	.175	.160	.156	.161	

AVERAGE LATERAL COMPONENT TURBULENCE INTENSITY AT SEA-TAC 27.0 M LEVEL  
BY WIND SPEED AND DIRECTION

DIR.	00GS.1	<1	1-3	3-5	5-7	7-9	9-11	>11	TOTAL
N	.211	.158	.176	.165	.22	0.000	0.000	0.000	.168
NNE	.209	.166	.122	.096	.088	0.000	0.000	0.000	.134
NE	.207	.124	.100	.094	.099	.061	.046	.114	.114
ENE	.240	.137	.112	.072	0.000	0.000	0.000	0.000	.127
E	.185	.140	.103	.104	0.000	0.000	0.000	0.000	.136
ESE	.150	.115	.077	.092	.081	.065	0.000	0.000	.106
SE	.142	.115	.095	.102	.069	0.000	0.000	0.000	.115
SSE	.232	.126	.111	.123	.30	0.000	0.000	0.000	.129
S	.190	.147	.146	.147	.140	.147	.166	.166	.148
SSW	.171	.181	.174	.158	.58	.150	0.000	0.000	.172
SW	.243	.202	.166	.172	.61	.157	.075	.182	.182
WSW	.415	.204	.172	.169	.79	0.000	0.000	0.000	.204
W	.132	.203	.201	.066	0.000	0.000	0.000	0.000	.198
WNW	.235	.197	.148	.393	0.000	0.000	0.000	0.000	.190
WW	.196	.228	.182	.170	.068	.110	0.000	0.000	.204
NNW	.426	.155	.182	.267	.346	.061	0.000	0.000	.193
	.230	.161	.152	.143	.38	.123	.123	.123	.123

AVERAGE VERTICAL COMPONENT TURBULENCE INTENSITY AT SEA-TAC 27.0 m LEVEL  
BY WIND SPEED AND DIRECTION

DIRN. (DEGS.)	<1	1-3	3-5	5-7	7-9	9-11	>11	TOTAL
N	.143	.116	.127	.129	.127	0.000	0.000	.123
NNE	.173	.128	.101	.093	.050	0.000	0.000	.110
NE	.170	.059	.080	.081	.091	.159	.197	.076
ENE	.332	.092	.078	.068	0.000	0.000	0.000	.095
E	.117	.076	.065	.082	0.000	0.000	0.000	.082
ESE	.003	.064	.063	.069	.066	.064	0.000	.060
SE	.054	.063	.076	.076	.196	0.000	0.000	.067
SSE	.138	.095	.094	.103	.125	0.000	0.000	.097
S	.067	.115	.116	.113	.114	.110	.107	.113
SSW	.156	.145	.145	.130	.127	.119	0.000	.142
SW	.192	.158	.140	.137	.156	.140	.246	.151
WSW	.434	.182	.160	.160	.172	0.000	0.000	.187
W	.043	.191	.138	.040	0.000	0.000	0.000	.172
WNW	.159	.165	.143	.205	0.000	0.000	0.000	.157
NW	.286	.176	.151	.264	.291	.230	0.000	.180
NNW	.199	.098	.130	.220	.235	.259	0.000	.129
	.144	.121	.123	.120	.128	.132	.152	

NUMBER OF OBSERVATIONS AVERAGED IN SEA-TAC 27.0 m LEVEL INTENSITY  
OF TURBULENCE TABLES BY WIND SPEED AND DIRECTION

DIRN. (DEGS.)	<1	1-3	3-5	5-7	7-9	9-11	>11	TOTAL
N	7,000	94,000	90,000	6,000	1,000	0,000	0,000	198,000
NNE	6,000	69,000	79,000	37,000	7,000	0,000	0,000	198,000
NE	3,000	36,000	27,000	16,000	1,000	2,000	1,000	86,000
ENE	2,000	26,000	17,000	4,000	0,000	0,000	0,000	49,000
E	11,000	25,000	13,000	7,000	0,000	0,000	0,000	56,000
ESE	7,000	67,000	21,000	4,000	10,000	2,000	0,000	111,000
SE	10,000	97,000	20,000	6,000	2,000	0,000	0,000	135,000
SSE	7,000	114,000	36,000	4,000	1,000	0,000	0,000	162,000
S	12,000	128,000	103,000	45,000	19,100	6,000	3,000	316,000
SSW	4,000	114,000	121,000	63,000	24,000	2,000	0,000	328,000
SW	6,000	90,000	101,000	42,000	13,000	2,000	1,000	255,000
WSW	5,000	65,000	31,000	2,000	1,000	0,000	0,000	104,000
W	3,000	52,000	15,000	1,000	0,000	0,000	0,000	71,000
WNW	4,000	49,000	33,000	1,000	0,000	0,000	0,000	87,000
NW	4,000	53,000	27,000	2,000	3,000	1,000	0,000	90,000
NNW	7,000	55,000	23,000	7,000	2,000	1,000	0,000	95,000
	68,000	1134,000	757,000	247,000	84,000	16,000	5,000	

## APPENDIX E

### TURBULENCE INTENSITY DISTRIBUTIONS

The percentage distributions of turbulence intensities are presented in this Appendix. Separate distributions are given for each site, level and component as in Appendix C. In this Appendix an additional categorization has been made. Separate distributions are given for wind flow over the two sectors at each site having the greatest difference in surface roughness. The sector to which each table applies is indicated at the top of the table. The total number of observations included in each table is given between the upper and lower sections of the table.

The tables in Appendix E are divided into an upper and lower portion. In the upper portion of the table, the percent frequency of occurrence of observed turbulence intensities is given by wind speed (in m/s) and turbulence intensity classes. The total of all entries in this portion should equal 100 percent (plus or minus small rounding errors). Again marginal distributions are provided.

In the lower portion of the table, the percent frequency of occurrence for each wind speed and intensity category has been normalized to the total percent frequency of occurrence for all observations in the wind speed category. Thus, each row totals 100 percent. The lower portions of these tables were used in compilation of the probability distributions presented in Chapter 9.

FREQUENCY DISTRIBUTIONS OF THE LONGITUDINAL COMPONENT TURBULENCE INTENSITY  
FOR THE ROUGH SECTOR AT THE LAKE UNION 6.9 m LEVEL BY WIND SPEED

SPEED (M/SEC)	0.00-0.05	0.05-0.10	0.10-0.15	0.15-0.20	0.20-0.25	0.25-0.30	0.30-0.35	0.35-0.40	0.40-0.45	>0.45	TOTAL
<1	0.00	0.00	0.00	.54	.41	.41	1.22	.54	2.71	5.62	
1-3	0.00	0.00	.68	5.68	11.91	11.10	8.93	4.87	2.71	4.60	50.47
3-5	0.00	0.00	0.00	3.52	13.40	11.10	5.14	1.89	.41	.27	35.72
5-7	0.00	0.00	0.00	.68	3.25	2.03	1.08	.14	0.00	0.00	7.17
7-9	0.00	0.00	0.00	0.00	.27	.27	0.00	0.00	0.00	0.00	.54
9-11	0.00	0.00	0.00	.14	0.30	0.00	0.00	.14	0.00	0.00	.27
>11	0.00	0.00	0.00	0.00	0.30	0.00	0.00	0.00	0.00	0.00	0.00
	0.00	0.00	.68	10.01	29.36	24.90	15.56	8.25	3.65	7.58	

TOTAL NO. OF OBSERVATIONS USED IN THIS TABLE = 739.

SPEED (M/SEC)	0.00-0.05	0.05-0.10	0.10-0.15	0.15-0.20	0.20-0.25	0.25-0.30	0.30-0.35	0.35-0.40	0.40-0.45	>0.45	TOTAL
<1	0.00	0.00	0.00	9.30	6.98	6.98	20.93	9.30	46.51	100.00	
1-3	0.00	0.00	1.34	11.26	23.59	21.98	17.69	9.65	5.36	9.12	100.00
3-5	0.00	0.00	0.00	9.85	37.50	31.06	14.30	5.30	1.14	.76	100.00
5-7	0.00	0.00	0.00	9.43	45.28	28.30	15.09	1.89	0.00	0.00	100.00
7-9	0.00	0.00	0.00	0.00	50.00	50.00	0.00	0.00	0.00	0.00	100.00
9-11	0.00	0.00	0.00	50.00	0.00	0.00	0.00	50.00	0.00	0.00	100.00
>11	0.00	0.00	0.00	0.00	0.00	0.00	0.00	0.00	0.00	0.00	0.00



FREQUENCY DISTRIBUTIONS OF THE VERTICAL COMPONENT TURBULENCE INTENSITY FOR  
THE ROUGH SECTOR AT THE LAKE UNION 6.9 m LEVEL BY WIND SPEED

SPEED (M/SEC)	0.00-0.05	0.05-0.10	0.10-0.15	0.15-0.20	0.20-0.25	0.25-0.30	0.30-0.35	0.35-0.40	0.40-0.45	>0.45	TOTAL
<I	.63	.68	.14	.68	.68	.68	.54	.41	.54	.68	5.82
1-3	.41	2.98	21.24	14.21	6.63	3.11	1.22	.41	0.00	.27	50.47
3-5	0.00	.14	20.84	12.31	2.30	0.00	.14	0.00	0.00	0.00	35.72
5-7	0.00	0.00	5.01	2.17	0.00	0.00	0.00	0.00	0.00	0.00	7.17
7-9	0.00	0.00	.27	.27	0.00	0.00	0.00	0.00	0.00	0.00	.54
9-II	0.00	0.00	.14	.14	0.00	0.00	0.00	0.00	0.00	0.00	.27
>II	0.00	0.00	0.00	0.00	0.00	0.00	0.00	0.00	0.00	0.00	0.00
	1.22	3.79	47.63	29.77	9.61	3.79	1.89	.61	.54	.95	

TOTAL NO. OF OBSERVATIONS USED IN THIS TABLE = 739.

SPEED (M/SEC)	0.00-0.05	0.05-0.10	0.10-0.15	0.15-0.20	0.20-0.25	0.25-0.30	0.30-0.35	0.35-0.40	0.40-0.45	>0.45	TOTAL
<I	13.95	11.63	2.33	11.63	11.63	11.63	9.30	6.98	9.30	11.63	100.00
1-3	.80	5.90	42.09	28.15	13.14	6.11	2.41	.80	0.00	.54	100.00
3-5	0.00	.38	58.33	36.47	6.44	0.00	.38	0.00	0.00	0.00	100.00
5-7	0.00	0.00	69.81	30.19	0.00	0.00	0.00	0.00	0.00	0.00	100.00
7-9	0.00	0.00	50.00	50.00	0.00	0.00	0.00	0.00	0.00	0.00	100.00
9-II	0.00	0.00	50.00	50.00	0.00	0.00	0.00	0.00	0.00	0.00	100.00
>II	0.00	0.00	0.00	0.00	0.00	0.00	0.00	0.00	0.00	0.00	0.00







FREQUENCY DISTRIBUTIONS OF THE LONGITUDINAL COMPONENT TURBULENCE INTENSITY  
FOR THE ROUGH SECTOR AT THE LAKE UNION 12.6 + 17.1 m LEVELS BY WIND SPEED

SPEED (M/SEC)	0.00-0.05	0.05-0.10	0.10-0.15	0.15-0.20	0.20-0.25	0.25-0.30	0.30-0.35	0.35-0.40	0.40-0.45	>0.45	TOTAL
<7	0.00	0.00	.13	.53	.27	.66	.13	.27	.27	1.86	4.12
1-3	0.00	0.00	1.46	6.37	10.76	10.36	6.11	3.59	2.39	3.32	44.36
3-5	0.00	0.00	1.33	7.84	11.69	10.00	3.98	1.46	.80	.13	37.32
5-7	0.00	0.00	0.00	2.12	5.98	2.92	1.06	0.00	0.00	0.00	12.08
7-9	0.00	0.00	0.00	.53	.73	.27	.13	0.00	0.00	0.00	1.86
9-11	0.00	0.00	0.00	0.00	0.10	0.00	.13	0.00	0.00	0.00	.13
>11	0.00	0.00	0.00	.13	0.10	0.00	0.00	0.00	0.00	0.00	.13
	0.00	0.00	2.92	17.53	29.11	24.30	11.55	5.31	3.45	5.31	

TOTAL NO. OF OBSERVATIONS USED IN THIS TABLE = 753.											
SPEED (M/SEC)	0.00-0.05	0.05-0.10	0.10-0.15	0.15-0.20	0.20-0.25	0.25-0.30	0.30-0.35	0.35-0.40	0.40-0.45	>0.45	TOTAL
<7	0.00	0.00	3.23	12.90	6.15	16.13	3.23	6.45	6.45	45.16	100.00
1-3	0.00	0.00	3.29	14.37	24.25	23.35	13.77	8.08	5.39	7.49	100.00
3-5	0.00	0.00	3.56	21.00	31.32	27.05	10.68	3.91	2.14	.36	100.00
5-7	0.00	0.00	0.00	17.58	49.45	24.18	8.79	0.00	0.00	0.00	100.00
7-9	0.00	0.00	0.00	28.57	50.00	14.29	7.14	0.00	0.00	0.00	100.00
9-11	0.00	0.00	0.00	0.00	0.00	0.00	100.00	0.00	0.00	0.00	100.00
>11	0.00	0.00	0.00	100.00	0.00	0.00	0.00	0.00	0.00	0.00	100.00



FREQUENCY DISTRIBUTIONS OF THE VERTICAL COMPONENT TURBULENCE INTENSITY FOR  
THE ROUGH SECTOR AT THE LAKE UNION 12.6 + 17.1 m LEVELS BY WIND SPEED

SPEED (M/SEC)	0.00-0.05	0.05-0.10	0.10-0.15	0.15-0.20	0.20-0.25	0.25-0.30	0.30-0.35	0.35-0.40	0.40-0.45	TOTAL
<7	.66	.66	0.00	.53	.13	.27	.13	.40	.27	1.06
1-7	.14	1.46	9.43	13.15	6.90	5.44	3.45	1.06	.40	.93
3-9	0.00	.66	10.89	18.73	6.24	.53	.13	.13	0.00	0.00
5-9	0.00	.13	3.98	7.70	.27	0.00	0.00	0.00	0.00	0.00
7-9	0.00	0.00	.53	1.33	0.00	0.00	0.00	0.00	0.00	0.00
9-11	0.00	0.00	0.00	.13	0.00	0.00	0.00	0.00	0.00	.13
>11	0.00	0.00	.13	0.00	0.00	0.00	0.00	0.00	0.00	.13
	.60	2.92	24.97	41.57	15.54	6.24	3.72	1.59	.66	1.99

TOTAL NO. OF OBSERVATIONS USED IN THIS TABLE = 753.

SPEED (M/SEC)	0.00-0.05	0.05-0.10	0.10-0.15	0.15-0.20	0.20-0.25	0.25-0.30	0.30-0.35	0.35-0.40	0.40-0.45	TOTAL
<7	16.13	16.13	0.00	12.90	3.23	6.45	3.23	9.68	6.45	25.81
1-7	.30	3.29	21.26	29.64	20.06	12.28	7.78	2.40	.90	2.10
3-9	0.00	1.78	29.18	50.18	16.72	1.42	.36	.36	0.00	0.00
5-9	0.00	1.10	32.97	63.74	2.20	0.00	0.00	0.00	0.00	0.00
7-9	0.00	0.00	28.57	71.43	0.00	9.00	0.00	0.00	0.00	0.00
9-11	0.00	0.00	0.00	100.00	0.00	0.00	0.00	0.00	0.00	0.00
>11	0.00	0.00	100.00	0.00	0.00	0.00	0.00	0.00	0.00	0.00



FREQUENCY DISTRIBUTIONS OF THE LATERAL COMPONENT TURBULENCE INTENSITY FOR  
THE SMOOTH SECTOR AT THE LAKE UNION 12.6 + 17.1 m LEVELS BY WIND SPEED

SPEED (M/SEC)	0.00-0.05	0.05-0.10	0.10-0.15	0.15-0.20	0.20-0.25	0.25-0.30	0.30-0.35	0.35-0.40	0.40-0.45	>0.45	TOTAL
cf	6.00	.01	.01	.00	2.02	.00	.00	.01	0.00	1.21	6.00
1-3	.01	5.26	15.79	6.91	6.00	3.24	.01	1.21	.00	.01	44.13
3-5	2.02	9.11	17.96	6.00	1.62	.00	.00	0.00	0.00	0.00	33.60
5-7	.00	4.06	4.05	3.24	.00	0.00	0.00	0.00	0.00	0.00	12.96
7-9	0.00	.01	.01	.01	0.00	0.00	0.00	0.00	0.00	0.00	2.43
9-11	0.00	0.00	0.00	0.00	0.00	0.00	0.00	0.00	0.00	0.00	0.00
>11	0.00	0.00	0.00	0.00	0.00	0.00	0.00	0.00	0.00	0.00	0.00
	3.26	21.05	34.41	20.24	10.03	4.05	1.62	2.02	.00	2.02	

TOTAL NO. OF OBSERVATIONS USED IN THIS TABLE = 247.

SPEED (M/SEC)	0.00-0.05	0.05-0.10	0.10-0.15	0.15-0.20	0.20-0.25	0.25-0.30	0.30-0.35	0.35-0.40	0.40-0.45	>0.45	TOTAL
cf	0.00	11.76	11.76	5.00	29.01	5.00	5.00	11.3	0.00	17.65	100.00
1-3	1.03	11.93	35.70	20.18	15.00	7.34	1.63	2.75	.92	1.03	100.00
3-5	6.02	27.71	28.35	20.48	4.02	1.20	1.20	0.00	0.00	0.00	100.00
5-7	3.13	37.50	31.25	25.00	3.73	0.00	0.00	0.00	0.00	0.00	100.00
7-9	0.00	33.13	33.33	33.33	0.00	0.00	0.00	0.00	0.00	0.00	100.00
9-11	0.00	0.00	0.00	0.00	0.00	0.00	0.00	0.00	0.00	0.00	0.00
>11	0.00	0.00	0.00	0.00	0.10	0.00	0.00	0.00	0.00	0.00	0.00



FREQUENCY DISTRIBUTIONS OF THE LONGITUDINAL COMPONENT TURBULENCE INTENSITY  
FOR THE ROUGH SECTOR AT THE LAKE UNION 24.8 m LEVEL BY WIND SPEED

SPEED (M/SEC)	0.00-0.05	0.05-0.10	0.10-0.15	0.15-0.20	0.20-0.25	0.25-0.30	0.30-0.35	0.35-0.40	0.40-0.45	>0.45	TOTAL
<1	0.00	0.00	0.00	.12	.12	.49	.12	.25	.25	1.23	2.59
1-3	0.00	.37	2.22	5.19	7.41	5.68	5.56	3.09	1.98	3.33	34.61
3-5	0.00	0.00	3.21	10.37	12.04	7.53	3.58	1.46	.37	.12	39.51
5-7	0.00	0.00	.66	5.68	6.54	2.96	.49	.25	0.00	0.00	16.79
7-9	0.00	0.00	0.00	1.65	2.22	1.23	0.00	0.00	0.00	0.00	5.31
9-11	0.00	0.00	0.00	.12	.62	.12	0.00	0.00	0.00	0.00	.86
>11	0.00	0.00	0.00	0.00	0.00	.12	0.00	0.00	0.00	0.00	.12
	0.00	.37	6.30	23.33	29.75	18.15	9.75	5.06	2.59	4.69	

E-14

TOTAL NO. OF OBSERVATIONS USED IN THIS TABLE = 810.

SPEED (M/SEC)	0.00-0.05	0.05-0.10	0.10-0.15	0.15-0.20	0.20-0.25	0.25-0.30	0.30-0.35	0.35-0.40	0.40-0.45	>0.45	TOTAL
<1	0.00	0.00	0.00	4.76	4.76	19.05	4.76	9.52	9.52	47.62	100.00
1-3	0.00	1.06	6.38	14.09	21.28	16.31	15.96	8.67	5.67	9.57	100.00
3-5	0.00	0.00	8.13	26.25	32.50	19.06	9.06	3.75	.94	.31	100.00
5-7	0.00	0.00	5.15	33.82	38.97	17.65	2.94	1.47	0.00	0.00	100.00
7-9	0.00	0.00	0.00	34.88	41.86	23.26	0.00	0.00	0.00	0.00	100.00
9-11	0.00	0.00	0.00	14.29	71.43	14.29	0.00	0.00	0.00	0.00	100.00
>11	0.00	0.00	0.00	0.00	0.00	100.00	0.00	0.00	0.00	0.00	100.00



FREQUENCY DISTRIBUTIONS OF THE VERTICAL COMPONENT TURBULENCE INTENSITY FOR  
THE ROUGH SECTOR AT THE LAKE UNION 24.8 m LEVEL BY WIND SPEED

SPEED {M/SEC}	0.00-0.05	0.05-0.10	0.10-0.15	0.15-0.20	0.20-0.25	0.25-0.30	0.30-0.35	0.35-0.40	0.40-0.45	>0.45	TOTAL
<1	.12	.37	.12	.49	.12	0.00	.37	.12	.12	.74	2.59
1-3	.25	1.73	6.30	6.15	7.90	3.95	3.33	1.73	.25	1.23	34.61
3-5	0.00	.62	12.59	19.14	5.80	.86	.37	.12	0.00	0.00	39.51
5-7	0.00	.12	6.15	7.16	1.36	0.00	0.00	0.00	0.00	0.00	16.79
7-9	0.00	0.00	2.72	2.59	0.00	0.00	0.00	0.00	0.00	0.00	5.31
9-11	0.00	0.00	.37	.49	0.00	0.00	0.00	0.00	0.00	0.00	.86
>11	0.00	0.00	0.00	.12	0.00	0.00	0.00	0.00	0.00	0.00	.12
	.37	2.84	30.25	38.15	15.19	4.81	4.07	1.98	.37	1.98	

TOTAL NO. OF OBSERVATIONS USED IN THIS TABLE = 810.

SPEED {M/SEC}	0.00-0.05	0.05-0.10	0.10-0.15	0.15-0.20	0.20-0.25	0.25-0.30	0.30-0.35	0.35-0.40	0.40-0.45	>0.45	TOTAL
<1	4.76	14.29	4.76	19.05	4.76	0.00	14.29	4.76	4.76	28.57	100.00
1-3	.71	4.96	18.09	23.40	22.70	11.35	9.57	4.96	.71	3.55	100.00
3-5	0.00	1.56	31.88	48.44	14.68	2.19	.94	.31	0.00	0.00	100.00
5-7	0.00	.74	48.53	42.65	8.09	0.00	0.00	0.00	0.00	0.00	100.00
7-9	0.00	0.00	51.16	48.84	9.80	0.00	0.00	0.00	0.00	0.00	100.00
9-11	0.00	0.00	42.86	57.14	9.80	0.00	0.00	0.00	0.00	0.00	100.00
>11	0.00	0.00	0.00	100.00	0.00	0.00	0.00	0.00	0.00	0.00	100.00







FREQUENCY DISTRIBUTIONS OF THE LONGITUDINAL COMPONENT TURBULENCE INTENSITY  
FOR THE ROUGH SECTOR AT THE LAKE UNION 48.2 m LEVEL BY WIND SPEED

SPEED (M/SEC)	0.00-0.05	0.05-0.10	0.10-0.15	0.15-0.20	0.20-0.25	0.25-0.30	0.30-0.35	0.35-0.40	0.40-0.45	>0.45	TOTAL
<1	0.00	.20	.61	.20	0.10	.20	.20	.41	0.00	.61	2.44
1-3	0.00	.41	.81	1.43	2.14	2.04	1.63	.61	1.22	1.02	11.61
3-5	0.00	1.02	6.31	8.96	7.13	4.28	1.02	.20	0.00	0.00	28.92
5-7	0.00	.61	6.11	15.07	6.52	4.46	1.63	.61	0.00	.61	35.85
7-9	0.00	.20	2.24	7.13	3.26	1.22	.61	.20	.20	0.00	15.07
9-11	0.00	0.00	1.02	1.83	.61	1.02	.20	0.00	0.00	0.00	4.89
>11	0.00	0.00	.20	.41	.41	.20	0.00	0.00	0.00	0.00	1.22
	0.00	2.44	17.31	35.03	20.57	13.44	5.30	2.04	1.43	2.44	

TOTAL NO. OF OBSERVATIONS USED IN THIS TABLE = 491.

SPEED (M/SEC)	0.00-0.05	0.05-0.10	0.10-0.15	0.15-0.20	0.20-0.25	0.25-0.30	0.30-0.35	0.35-0.40	0.40-0.45	>0.45	TOTAL
<1	0.00	8.33	25.00	8.33	0.00	8.33	8.33	16.67	0.00	25.00	100.00
1-3	0.00	3.51	7.62	12.28	21.05	17.54	14.04	5.26	10.53	8.77	100.00
3-5	0.00	3.52	21.83	30.99	24.65	14.79	3.52	.70	0.00	0.00	100.00
5-7	0.00	1.70	17.05	42.05	18.18	12.50	4.55	1.70	0.00	2.27	100.00
7-9	0.00	1.35	14.86	47.30	21.62	8.11	4.05	1.35	1.35	0.00	100.00
9-11	0.00	0.00	20.83	37.50	16.67	20.83	4.17	0.00	0.00	0.00	100.00
>11	0.00	0.00	16.67	33.33	33.33	16.67	0.00	0.00	0.00	0.00	100.00

**FREQUENCY OF DISTRIBUTIONS OF THE LATERAL COMPONENT TURBULENCE INTENSITY  
FOR THE ROUGH SECTOR AT THE LAKE UNION 48.2 m LEVEL**

SPEED (M/SEC)	0.00-0.05	0.05-0.10	0.10-0.15	0.15-0.20	0.20-0.25	0.25-0.30	0.30-0.35	0.35-0.40	0.40-0.45	>0.45	TOTAL
<I	0.00	0.00	.41	.20	.41	.20	.20	.20	0.00	.81	2.44
1-3	.20	1.43	.20	2.65	2.65	1.83	1.07	.61	.20	.81	11.61
3-5	0.00	3.26	10.18	6.15	5.70	.81	.81	0.00	0.00	0.00	28.92
5-7	0.00	7.13	13.65	6.76	5.70	.20	.20	.20	0.00	0.00	35.85
7-9	0.00	3.87	6.92	3.46	.51	.20	0.00	0.00	0.00	0.00	15.07
9-11	.20	1.63	2.26	.61	.20	0.00	0.00	0.00	0.00	0.00	4.89
>11	0.00	.20	.61	.20	0.00	0.00	.20	0.00	0.00	0.00	1.27
	.41	17.52	34.22	24.03	15.27	3.26	2.44	1.02	.20	1.63	

1. TOTAL NO. OF OBSERVATIONS USED IN THIS TABLE = 491.

SPEED (M/SEC)	0.00-0.05	0.05-0.10	0.10-0.15	0.15-0.20	0.20-0.25	0.25-0.30	0.30-0.35	0.35-0.40	0.40-0.45	>0.45	TOTAL
<I	0.00	0.00	16.67	6.33	16.67	6.33	6.33	6.33	0.00	33.33	100.00
1-3	1.75	12.28	1.75	22.61	22.61	15.79	8.77	5.26	1.75	7.02	100.00
3-5	0.00	11.27	35.21	28.17	19.72	2.82	2.82	0.00	0.00	0.00	100.00
5-7	0.00	19.89	38.87	24.43	15.91	.57	.57	.57	0.00	0.00	100.00
7-9	0.00	25.68	45.95	22.97	4.05	1.35	0.00	0.00	0.00	0.00	100.00
9-11	4.17	33.33	45.83	12.50	4.17	0.00	0.00	0.00	0.00	0.00	100.00
>11	0.00	16.67	50.00	16.67	0.00	0.00	16.67	0.00	0.00	0.00	100.00











FREQUENCY DISTRIBUTIONS OF THE LATERAL COMPONENT TURBULENCE INTENSITY FOR  
THE ROUGH SECTOR AT THE KIXI 77.1 m LEVEL BY WIND SPEED

SPEED (M/SEC)	0-00-0.05	0.05-0.10	0.10-0.15	0.15-0.20	0.20-0.25	0.25-0.30	0.30-0.35	0.35-0.40	0.40-0.45	>0.45	TOTAL
<1	0.00	0.00	0.00	0.00	0.00	0.00	.41	0.00	0.00	.41	.83
1-3	0.00	0.00	1.65	2.07	5.37	6.20	4.13	2.89	2.07	3.72	28.10
3-5	.41	2.07	5.79	7.44	10.74	7.02	7.02	3.31	.83	2.48	47.11
5-7	0.00	0.00	2.89	1.65	3.72	2.89	1.65	.83	.41	0.00	14.05
7-9	0.00	0.00	.83	2.07	3.31	2.07	.41	.41	0.00	0.00	9.09
9-11	0.00	0.00	0.00	0.00	0.00	.41	.41	0.00	0.00	0.00	.83
>11	0.00	0.00	0.00	0.00	0.00	0.00	0.00	0.00	0.00	0.00	0.00
	.41	2.07	11.16	13.22	23.14	18.60	14.05	7.44	3.31	6.61	

TOTAL NO. OF OBSERVATIONS USED IN THIS TABLE = 242.

SPEED (M/SEC)	0-00-0.05	0.05-0.10	0.10-0.15	0.15-0.20	0.20-0.25	0.25-0.30	0.30-0.35	0.35-0.40	0.40-0.45	>0.45	TOTAL
<1	0.00	0.00	0.00	0.00	0.00	0.00	50.00	0.00	0.00	50.00	100.00
1-3	0.00	0.00	5.88	7.35	19.12	22.06	14.71	10.29	7.35	13.24	100.00
3-5	.83	4.39	12.28	15.79	22.81	14.91	14.91	7.02	1.75	5.26	100.00
5-7	0.00	0.00	20.59	11.76	26.47	20.59	11.76	5.88	2.94	0.00	100.00
7-9	0.00	0.00	9.69	22.73	36.36	22.73	4.55	4.55	0.00	0.00	100.00
9-11	0.00	0.00	0.00	0.00	0.00	50.00	50.00	0.00	0.00	0.00	100.00
>11	0.00	0.00	0.00	0.00	0.00	0.00	0.00	0.00	0.00	0.00	0.00

FREQUENCY DISTRIBUTIONS OF THE VERTICAL COMPONENT TURBULENCE INTENSITY FOR  
THE ROUGH SECTOR AT THE KIXI 77.1 M LEVEL BY WIND SPEED

SPEED (M/SEC)	0.00-0.05	0.05-0.10	0.10-0.15	0.15-0.20	0.20-0.25	0.25-0.30	0.30-0.35	0.35-0.40	0.40-0.45	>0.45	TOTAL
<1	0.00	0.00	.41	0.00	.41	0.00	0.00	0.00	0.00	0.00	.83
1-3	.41	2.07	7.44	7.44	5.37	2.89	2.07	.41	0.00	0.00	28.10
3-4	.83	16.33	20.25	9.09	3.31	2.48	.83	0.00	0.00	0.00	47.11
5-7	0.00	3.31	7.02	1.65	.83	.41	.41	0.00	0.00	0.00	14.05
7-9	0.00	.83	2.48	4.96	.83	0.00	0.00	0.00	0.00	0.00	9.09
9-11	0.00	0.00	0.00	.83	0.00	0.00	0.00	0.00	0.00	0.00	.83
>11	0.00	0.00	0.00	0.00	0.00	0.00	0.00	0.00	0.00	0.00	0.00
	1.24	16.53	37.60	23.97	10.74	5.79	3.31	.83	0.00	0.00	100.00

TOTAL NO. OF OBSERVATIONS USED IN THIS TABLE = 242.

SPEED (M/SEC)	0.00-0.05	0.05-0.10	0.10-0.15	0.15-0.20	0.20-0.25	0.25-0.30	0.30-0.35	0.35-0.40	0.40-0.45	>0.45	TOTAL
<1	0.00	0.00	50.00	0.00	0.00	0.00	0.00	0.00	0.00	0.00	100.00
1-3	1.47	7.35	26.47	26.47	19.12	10.29	7.35	1.47	0.00	0.00	100.00
3-4	1.75	21.93	42.68	19.30	7.02	5.26	1.75	0.00	0.00	0.00	100.00
5-7	0.00	23.53	50.00	11.76	3.88	2.94	2.94	0.00	0.00	0.00	100.00
7-9	0.00	9.09	27.27	54.55	9.09	0.00	0.00	0.00	0.00	0.00	100.00
9-11	0.00	0.00	0.00	100.00	0.00	0.00	0.00	0.00	0.00	0.00	100.00
>11	0.00	0.00	0.00	0.00	0.00	0.00	0.00	0.00	0.00	0.00	0.00

FREQUENCY DISTRIBUTIONS OF THE LONGITUDINAL COMPONENT TURBULENCE INTENSITY  
FOR THE SMOOTH SECTOR AT THE KIXI 77.1 m LEVEL BY WIND SPEED

SPEED (m/SEC)	0.00-0.05	0.05-0.10	0.10-0.15	0.15-0.20	0.20-0.25	0.25-0.30	0.30-0.35	0.35-0.40	0.40-0.45	>0.45	TOTAL
<1	0.00	0.00	0.00	0.00	0.00	0.00	0.00	0.73	0.36	1.46	2.55
1-3	0.00	4.38	8.63	5.84	7.30	6.20	2.19	2.19	0.73	3.28	40.15
3-5	1.09	6.20	9.12	6.93	4.01	2.92	3.28	0.73	1.09	0.00	35.40
5-7	0.00	1.46	4.74	4.74	4.01	0.73	0.73	0.36	0.00	0.00	16.79
7-9	0.00	0.36	1.46	1.62	0.36	0.00	0.00	0.00	0.00	0.00	4.01
9-11	0.00	0.36	0.36	0.00	0.00	0.00	0.00	0.00	0.00	0.00	1.09
>11	0.00	0.00	0.00	0.00	0.00	0.00	0.00	0.00	0.00	0.00	0.00
TOTAL	1.09	12.77	24.09	19.34	15.69	9.85	6.20	4.01	2.19	4.74	

TOTAL NO. OF OBSERVATIONS USED IN THIS TABLE = 274.

SPEED (m/SEC)	0.00-0.05	0.05-0.10	0.10-0.15	0.15-0.20	0.20-0.25	0.25-0.30	0.30-0.35	0.35-0.40	0.40-0.45	>0.45	TOTAL
<1	0.00	0.00	0.00	0.00	0.00	0.00	0.00	28.57	14.29	57.14	100.00
1-3	0.00	10.91	20.00	14.55	18.18	15.45	5.45	5.45	1.82	8.18	100.00
3-5	3.09	17.53	25.77	19.59	11.34	8.25	9.28	2.06	3.09	0.00	100.00
5-7	0.00	6.70	28.26	28.26	23.01	4.35	4.35	2.17	0.00	0.00	100.00
7-9	0.00	9.09	36.36	45.45	9.09	0.00	0.00	0.00	0.00	0.00	100.00
9-11	0.00	33.33	66.67	0.00	0.00	0.00	0.00	0.00	0.00	0.00	100.00
>11	0.00	0.00	0.00	0.00	0.00	0.00	0.00	0.00	0.00	0.00	0.00



FREQUENCY DISTRIBUTIONS OF THE VERTICAL COMPONENT TURBULENCE INTENSITY FOR  
THE SMOOTH SECTOR AT THE KIXI 77.1 M LEVEL BY WIND SPEED

SPEED (M/SEC)	0.00-0.05	0.05-0.10	0.10-0.15	0.15-0.20	0.20-0.25	0.25-0.30	0.30-0.35	0.35-0.40	0.40-0.45	>0.45	TOTAL
<1	0.00	.37	1.10	.37	0.00	0.00	0.00	0.00	0.00	.37	2.56
1-3	7.60	16.85	7.69	5.13	1.47	.73	0.00	.37	0.00	.37	40.29
3-5	10.69	15.75	8.42	.73	0.00	0.00	0.00	0.00	0.00	0.00	35.53
5-7	6.23	8.79	1.47	0.00	0.00	0.00	0.00	0.00	0.00	0.00	16.48
7-9	.37	3.66	0.00	0.00	0.00	0.00	0.00	0.00	0.00	0.00	4.03
9-11	.73	.37	0.00	0.00	0.00	0.00	0.00	0.00	0.00	0.00	1.10
>11	0.00	0.00	0.00	0.00	0.00	0.00	0.00	0.00	0.00	0.00	0.00
TOTAL	25.64	65.79	18.68	6.23	1.83	.73	0.00	.37	0.00	.73	

TOTAL NO. OF OBSERVATIONS USED IN THIS TABLE = 273.

SPEED (M/SEC)	0.00-0.05	0.05-0.10	0.10-0.15	0.15-0.20	0.20-0.25	0.25-0.30	0.30-0.35	0.35-0.40	0.40-0.45	>0.45	TOTAL
<1	0.00	14.29	42.86	14.29	14.29	0.00	0.00	0.00	0.00	14.29	100.00
1-3	19.09	41.82	19.09	12.73	3.64	1.82	0.00	.91	0.00	.91	100.00
3-5	29.90	44.32	23.71	2.06	0.00	0.00	0.00	0.00	0.00	0.00	100.00
5-7	37.78	53.33	8.89	0.00	0.00	0.00	0.00	0.00	0.00	0.00	100.00
7-9	9.09	90.91	0.00	0.00	0.00	0.00	0.00	0.00	0.00	0.00	100.00
9-11	66.67	33.33	0.00	0.00	0.00	0.00	0.00	0.00	0.00	0.00	100.00
>11	0.00	0.00	0.00	0.00	0.00	0.00	0.00	0.00	0.00	0.00	0.00

FREQUENCY DISTRIBUTIONS OF THE LONGITUDINAL COMPONENT TURBULENCE INTENSITY  
FOR THE ROUGH SECTOR AT THE KIXI 95.4 m LEVEL BY WIND SPEED

SPEED (M/SEC)	0.00-0.05	0.05-0.10	0.10-0.15	0.15-0.20	0.20-0.25	0.25-0.30	0.30-0.35	0.35-0.40	0.40-0.45	>0.45	TOTAL
<1	0.00	0.00	0.00	0.00	0.00	.40	1.20	1.60	0.00	1.20	4.40
1-3	0.00	0.00	1.20	4.80	6.40	0.80	3.60	2.00	3.20	3.60	33.60
3-5	0.00	.80	6.80	8.00	11.60	9.20	5.20	2.80	.40	.80	45.20
5-7	0.00	0.00	2.40	2.00	4.80	1.20	1.60	1.60	.80	0.00	14.40
7-9	0.00	0.00	0.00	.40	1.60	.40	0.00	0.00	0.00	0.00	2.40
9-11	0.00	0.00	0.00	0.00	0.00	0.00	0.00	0.00	0.00	0.00	0.00
>11	0.00	0.00	0.00	0.00	0.00	0.00	0.00	0.00	0.00	0.00	0.00
	0.00	.80	10.00	15.20	24.40	20.00	11.60	8.00	4.40	5.60	

TOTAL NO. OF OBSERVATIONS USED IN THIS TABLE = 250.

SPEED (M/SEC)	0.00-0.05	0.05-0.10	0.10-0.15	0.15-0.20	0.20-0.25	0.25-0.30	0.30-0.35	0.35-0.40	0.40-0.45	>0.45	TOTAL
<1	0.00	0.00	0.00	0.00	0.00	9.09	27.27	36.36	0.00	27.27	100.00
1-3	0.00	0.00	3.57	14.29	19.05	26.19	10.71	5.95	9.52	10.71	100.00
3-5	0.00	1.77	14.16	17.70	25.66	20.35	11.50	6.19	.88	1.77	100.00
5-7	0.00	0.00	16.67	13.89	23.33	8.33	11.11	11.11	5.56	0.00	100.00
7-9	0.00	0.00	0.00	16.67	66.67	16.67	0.00	0.00	0.00	0.00	100.00
9-11	0.00	0.00	0.00	0.00	0.00	0.00	0.00	0.00	0.00	0.00	0.00
>11	0.00	0.00	0.00	0.00	0.00	0.00	0.00	0.00	0.00	0.00	0.00



FREQUENCY DISTRIBUTIONS OF THE VERTICAL COMPONENT TURBULENCE INTENSITY FOR  
THE ROUGH SECTOR AT THE KIXI 95.4 m LEVEL BY WIND SPEED

SPEED (M/SEC)	0.00-0.05	0.05-0.10	0.10-0.15	0.15-0.20	0.20-0.25	0.25-0.30	0.30-0.35	0.35-0.40	0.40-0.45	>0.45	TOTAL
<1	0.00	0.00	0.00	.00	.40	0.00	1.20	0.00	.40	1.60	4.40
1-3	0.00	.40	3.20	4.00	6.00	5.20	6.00	2.00	1.60	2.80	33.60
3-5	0.00	.40	0.20	12.60	15.20	3.20	4.00	0.00	0.00	0.00	45.20
5-7	0.00	1.20	4.00	4.00	3.40	1.60	0.00	0.00	0.00	0.00	17.40
7-9	0.00	0.00	1.60	.40	.40	.00	0.00	0.00	0.00	0.00	2.40
9-11	0.00	0.00	0.00	0.00	0.00	0.00	0.00	0.00	0.60	0.00	0.00
>11	0.00	0.00	0.00	0.00	0.00	0.00	0.00	0.00	0.00	0.00	0.00
	0.00	2.00	18.00	22.60	26.40	18.00	11.60	2.00	2.00	4.40	

TOTAL NO. OF OBSERVATIONS USED IN THIS TABLE = 250.

SPEED (M/SEC)	0.00-0.05	0.05-0.10	0.10-0.15	0.15-0.20	0.20-0.25	0.25-0.30	0.30-0.35	0.35-0.40	0.40-0.45	>0.45	TOTAL
<1	0.00	0.00	18.10	9.00	0.00	27.27	0.00	9.09	36.36	100.00	
1-3	0.00	1.19	9.52	14.29	20.24	15.48	17.06	0.33	4.76	8.33	100.00
3-5	0.00	.86	20.35	28.32	33.63	7.08	9.73	0.00	0.00	0.00	100.00
5-7	0.00	0.33	27.78	27.78	25.00	11.11	0.00	0.00	0.00	0.00	100.00
7-9	0.00	0.00	66.67	16.67	0.00	0.00	0.00	0.00	0.00	0.00	100.00
9-11	0.00	0.00	0.00	0.00	0.00	0.00	0.00	0.00	0.00	0.00	0.00
>11	0.00	0.00	0.00	0.00	0.00	0.00	0.00	0.00	0.00	0.00	0.00

FREQUENCY DISTRIBUTIONS OF THE LONGITUDINAL COMPONENT TURBULENCE INTENSITY  
FOR THE SMOOTH SECTION AT THE KIXI 95.4 m LEVEL BY WIND SPEED

SPEED (M/SEC)	0.00-0.05	0.05-0.10	0.10-0.15	0.15-0.20	0.20-0.25	0.25-0.30	0.30-0.35	0.35-0.40	0.40-0.45	>0.45	TOTAL
<1	0.00	0.00	.36	.71	.36	.71	0.00	0.00	.36	2.49	5.69
1-3	.36	6.41	8.90	10.68	5.34	5.69	1.78	1.42	.71	.36	41.64
3-5	1.62	7.12	7.47	7.83	6.41	4.27	.36	0.00	0.00	0.00	34.88
5-7	0.00	2.65	7.12	1.78	1.42	.71	0.00	0.00	0.00	0.00	13.88
7-9	0.00	.36	1.78	.71	.36	0.00	0.00	0.00	0.00	0.00	3.20
9-11	.36	.36	0.00	0.00	0.00	0.00	0.00	0.00	0.00	0.00	.71
>11	0.00	0.00	0.00	0.00	0.00	0.00	0.00	0.00	0.00	0.00	0.00
TOTAL	2.14	17.08	25.62	21.71	14.23	11.03	2.85	1.42	1.07	2.85	

TOTAL NO. OF OBSERVATIONS USED IN THIS TABLE = 281.

SPEED (M/SEC)	0.00-0.05	0.05-0.10	0.10-0.15	0.15-0.20	0.20-0.25	0.25-0.30	0.30-0.35	0.35-0.40	0.40-0.45	>0.45	TOTAL
<1	0.00	0.00	6.25	12.50	12.50	6.25	12.50	0.00	6.25	43.75	100.00
1-3	.85	15.36	21.37	25.64	12.62	13.68	4.27	3.42	1.71	.85	100.00
3-5	4.08	20.41	21.43	22.45	18.37	12.24	1.02	0.00	0.00	0.00	100.00
5-7	0.00	20.51	51.28	12.82	10.26	5.13	0.00	0.00	0.00	0.00	100.00
7-9	0.00	11.11	55.56	22.22	11.11	0.00	0.00	0.00	0.00	0.00	100.00
9-11	50.00	50.00	0.00	0.00	0.00	0.00	0.00	0.00	0.00	0.00	100.00
>11	0.00	0.00	0.00	0.00	0.00	0.00	0.00	0.00	0.00	0.00	0.00



FREQUENCY DISTRIBUTIONS OF THE VERTICAL COMPONENT TURBULENCE INTENSITY FOR  
THE SMOOTH SECTOR AT THE KIXI 95.4 m LEVEL BY WIND SPEED

WIND SPEED (M/SEC)	0.00-0.05	0.05-0.10	0.10-0.15	0.15-0.20	0.20-0.25	0.25-0.30	0.30-0.35	0.35-0.40	0.40-0.45	TOTAL
<1	.71	0.00	.71	1.07	0.00	1.07	0.00	.71	.71	5.71
1-1	3.21	12.14	10.36	6.57	3.21	1.79	.36	.71	.71	41.79
2-1	3.57	7.14	11.79	7.86	4.29	.36	0.00	0.00	0.00	35.00
3-1	0.00	5.36	6.79	1.43	.36	0.00	0.00	0.00	0.00	13.93
4-1	0.00	1.79	1.07	.36	0.00	0.00	0.00	0.00	0.00	3.21
5-1	0.00	0.00	.36	0.00	0.00	0.00	0.00	0.00	0.00	.36
6-1	0.00	0.00	0.00	0.00	0.00	0.00	0.00	0.00	0.00	0.00
7-1	7.50	27.14	30.36	18.93	8.93	2.14	1.43	.71	1.43	1.43

TOTAL NO. OF OBSERVATIONS USED IN THIS TABLE = 280.

WIND SPEED (M/SEC)	0.00-0.05	0.05-0.10	0.10-0.15	0.15-0.20	0.20-0.25	0.25-0.30	0.30-0.35	0.35-0.40	0.40-0.45	TOTAL
<1	12.50	12.50	0.00	12.50	15.75	0.00	10.75	0.00	12.50	12.50
1-1	7.60	29.00	24.79	20.51	7.69	4.27	.65	1.71	1.71	1.71
2-1	16.20	20.41	33.67	22.45	12.04	1.02	0.00	0.00	0.00	0.00
3-1	0.00	38.46	48.72	10.26	2.46	0.00	0.00	0.00	0.00	0.00
4-1	0.00	55.56	33.33	11.11	0.10	0.00	0.00	0.00	0.00	0.00
5-1	0.00	0.00	100.00	0.00	0.00	0.00	0.00	0.00	0.00	0.00
6-1	0.00	0.00	0.00	0.00	0.00	0.00	0.00	0.00	0.00	0.00



FREQUENCY DISTRIBUTIONS OF THE LATERAL COMPONENT TURBULENCE INTENSITY FOR  
THE ROUGH SECTOR AT THE SEA-TAC 7.1 m LEVEL BY WIND SPEED

SPEED (M/SEC)	0.00-0.05	0.05-0.10	0.10-0.15	0.15-0.20	0.20-0.25	0.25-0.30	0.30-0.35	0.35-0.40	0.40-0.45	TOTAL
<7	0.00	.77	.96	1.16	1.16	.34	.19	.39	.19	.58
1-4	0.00	.77	6.17	14.45	9.83	6.36	5.20	2.12	1.73	3.28
3-6	0.00	0.00	4.24	11.37	8.09	4.05	1.73	.19	.19	.19
5-7	.10	0.00	1.35	4.62	4.43	.19	.19	0.00	0.00	.19
7-9	0.00	.19	.19	.77	1.34	.19	0.00	0.00	0.00	0.00
9-11	0.00	0.00	0.00	0.00	0.00	0.00	0.00	0.00	0.00	0.00
>11	0.00	0.00	0.00	0.00	0.00	0.00	0.00	0.00	0.00	0.00
TOTAL	.37	1.73	13.10	32.37	24.86	11.14	7.32	2.70	2.12	4.24

NO. OF OBSERVATIONS USED IN THIS TABLE = 519.

SPEED (M/SEC)	0.00-0.05	0.05-0.10	0.10-0.15	0.15-0.20	0.20-0.25	0.25-0.30	0.30-0.35	0.35-0.40	0.40-0.45	TOTAL
<7	0.00	13.33	16.67	20.00	20.00	6.67	3.33	6.67	3.33	10.00
1-4	0.00	1.54	12.36	28.96	19.69	12.74	10.42	4.25	3.47	6.56
3-6	0.00	0.00	14.10	37.82	26.32	13.44	5.77	.64	.64	.64
5-7	3.70	0.00	11.86	40.68	38.94	1.69	1.69	0.00	0.00	1.69
7-9	0.00	6.47	13.33	26.67	46.67	6.67	0.00	0.00	0.00	0.00
9-11	0.00	0.00	0.00	0.00	0.00	0.00	0.00	0.00	0.00	0.00
>11	0.00	0.00	0.00	0.00	0.00	0.00	0.00	0.00	0.00	0.00
TOTAL	3.70	14.83	40.68	107.45	142.68	54.61	31.81	12.56	7.44	20.90

FREQUENCY DISTRIBUTIONS OF THE VERTICAL COMPONENT TURBULENCE INTENSITY FOR  
THE ROUGH SECTOR AT THE SEA-TAC 7.1 m LEVEL BY WIND SPEED

SPEED (M/SEC)	0.00-0.05	0.05-0.10	0.10-0.15	0.15-0.20	0.20-0.25	0.25-0.30	0.30-0.35	0.35-0.40	0.40-0.45	TOTAL
<1	2.32	1.16	.77	.19	.39	.19	.19	0.00	0.00	50.45
1-3	1.54	11.24	18.15	11.58	4.93	.77	1.16	.58	.19	.39
3-5	0.00	4.25	22.20	3.09	.39	.19	0.00	0.00	0.00	0.00
5-7	.10	2.51	7.92	.19	0.30	0.00	.30	.19	0.00	0.00
7-9	0.00	.58	1.54	.19	0.30	.39	.19	0.00	0.00	0.00
9-11	0.00	0.00	0.00	0.00	0.30	0.00	0.00	0.00	0.00	0.00
>11	0.00	0.00	0.00	0.00	0.30	0.00	0.00	0.00	0.00	0.00
	4.04	19.49	58.58	15.25	5.50	1.54	1.93	.77	.19	.39

TOTAL NO. OF OBSERVATIONS USED IN THIS TABLE = 515.

SPEED (M/SEC)	0.00-0.05	0.05-0.10	0.10-0.15	0.15-0.20	0.20-0.25	0.25-0.30	0.30-0.35	0.35-0.40	0.40-0.45	TOTAL
<1	41.34	20.69	13.79	3.45	6.30	3.45	3.45	0.00	0.00	6.90
1-3	3.00	22.30	36.29	23.17	9.55	1.54	2.32	1.16	.39	0.00
3-5	0.00	14.10	73.72	10.26	1.25	.64	0.00	0.00	0.00	0.00
5-7	1.60	22.07	69.49	1.69	0.20	0.00	3.30	1.69	0.00	0.00
7-9	0.00	20.00	53.33	6.67	0.00	13.33	6.67	0.00	0.00	0.00
9-11	0.00	0.00	0.00	0.00	0.00	0.00	0.00	0.00	0.00	0.00
>11	0.00	0.00	0.00	0.00	0.10	0.00	0.00	0.00	0.00	0.00

FREQUENCY DISTRIBUTIONS OF THE LONGITUDINAL COMPONENT TURBULENCE INTENSITY  
FOR THE SMOOTH SECTOR AT THE SEA-TAC 7.1 m LEVEL BY WIND SPEED

SPEED (m/SEC)	0.00-0.05	0.05-0.10	0.10-0.15	0.15-0.20	0.20-0.25	0.25-0.30	0.30-0.35	0.35-0.40	0.40-0.45	>0.45	TOTAL
<1	.49	1.46	2.93	.98	.98	.96	.49	.49	.49	.98	10.24
1-4	1.46	12.68	23.90	14.15	5.85	3.41	.98	1.95	0.00	.98	65.37
3-5	0.00	0.00	5.85	9.76	2.93	0.00	0.00	0.00	0.00	0.00	18.54
5-7	0.00	0.00	.49	3.90	1.46	0.00	0.00	0.00	0.00	0.00	5.85
7-9	0.00	0.00	0.00	0.00	0.00	0.00	0.00	0.00	0.00	0.00	0.00
9-11	0.00	0.00	0.00	0.00	0.00	0.00	0.00	0.00	0.00	0.00	0.00
>11	0.00	0.00	0.00	0.00	0.00	0.00	0.00	0.00	0.00	0.00	0.00
	1.95	14.15	33.17	28.78	11.22	4.39	1.46	2.44	.49	1.95	

TOTAL NO. OF OBSERVATIONS USED IN THIS TABLE = 205.											
SPEED (m/SEC)	0.00-0.05	0.05-0.10	0.10-0.15	0.15-0.20	0.20-0.25	0.25-0.30	0.30-0.35	0.35-0.40	0.40-0.45	>0.45	TOTAL
<1	4.76	14.29	28.57	9.52	9.52	9.52	4.76	4.76	4.76	9.52	100.00
1-4	2.24	19.40	36.57	21.64	8.96	5.22	1.49	2.99	0.00	1.49	100.00
3-5	0.00	0.00	31.58	52.63	15.79	0.00	0.00	0.00	0.00	0.00	100.00
5-7	0.00	0.00	6.33	66.67	25.00	0.00	0.00	0.00	0.00	0.00	100.00
7-9	0.00	0.00	0.00	0.00	0.00	0.00	0.00	0.00	0.00	0.00	0.00
9-11	0.00	0.00	0.00	0.00	0.00	0.00	0.00	0.00	0.00	0.00	0.00
>11	0.00	0.00	0.00	0.00	0.00	0.00	0.00	0.00	0.00	0.00	0.00

FREQUENCY DISTRIBUTIONS OF THE LATERAL COMPONENT TURBULENCE INTENSITY FOR  
THE SMOOTH SECTOR AT THE SEA-TAC 7.1 m LEVEL BY WIND SPEED

SPEED (m/sec)	0.00-0.05	0.05-0.10	0.10-0.15	0.15-0.20	0.20-0.25	0.25-0.30	0.30-0.35	0.35-0.40	0.40-0.45	>0.45	TOTAL
<1	0.00	1.46	3.90	3.90	0.00	0.00	0.00	0.00	0.00	0.98	10.24
1-4	2.92	21.46	23.90	6.76	4.18	1.46	.49	0.00	0.00	1.46	65.37
3-6	0.00	2.93	9.27	5.65	.69	0.00	0.00	0.00	0.00	0.00	18.54
5-7	0.00	0.00	3.41	1.95	.69	0.00	0.00	0.00	0.00	0.00	5.85
7-9	0.00	0.00	0.00	0.00	0.00	0.00	0.00	0.00	0.00	0.00	0.00
9-11	0.00	0.00	0.00	0.00	0.00	0.00	0.00	0.00	0.00	0.00	0.00
>11	0.00	0.00	0.00	0.00	0.00	0.00	0.00	0.00	0.00	0.00	0.00
	2.92	25.85	40.49	20.49	5.85	1.46	.49	0.00	0.00	2.44	

TOTAL NO. OF OBSERVATIONS USED IN THIS TABLE = 205.

SPEED (m/sec)	0.00-0.05	0.05-0.10	0.10-0.15	0.15-0.20	0.20-0.25	0.25-0.30	0.30-0.35	0.35-0.40	0.40-0.45	>0.45	TOTAL
<1	0.00	14.20	38.10	38.10	0.00	0.00	0.00	0.00	0.00	9.52	100.00
1-4	6.88	32.86	36.57	13.43	7.46	2.24	.75	0.00	0.00	2.24	100.00
3-6	0.00	15.79	50.00	31.58	2.63	0.00	0.00	0.00	0.00	0.00	100.00
5-7	0.00	0.00	58.33	33.33	6.33	0.00	0.00	0.00	0.00	0.00	100.00
7-9	0.00	0.00	0.00	0.00	0.00	0.00	0.00	0.00	0.00	0.00	0.00
9-11	0.00	0.00	0.00	0.00	0.00	0.00	0.00	0.00	0.00	0.00	0.00
>11	0.00	0.00	0.00	0.00	0.00	0.00	0.00	0.00	0.00	0.00	0.00
	0.00	0.00	0.00	0.00	0.00	0.00	0.00	0.00	0.00	0.00	

FREQUENCY DISTRIBUTIONS OF THE VERTICAL COMPONENT TURBULENCE INTENSITY FOR  
THE SMOOTH SECTOR AT THE SEA-TAC 7.1 M LEVEL BY WIND SPEED

SPEED (M/SEC)	0.00-0.05	0.05-0.10	0.10-0.15	0.15-0.20	0.20-0.25	0.25-0.30	0.30-0.35	0.35-0.40	0.40-0.45	>0.45	TOTAL
<1	6.63	0.00	0.00	.51	.51	0.00	.51	0.00	0.00	0.00	8.16
1-4	45.20	22.96	5.10	1.53	.51	1.02	0.00	0.00	0.00	0.00	66.33
3-5	.51	18.37	.51	0.00	0.00	0.00	0.00	0.00	0.00	0.00	19.39
5-7	0.00	6.12	0.00	0.00	0.00	0.00	0.00	0.00	0.00	0.00	6.12
7-9	0.00	0.00	0.00	0.00	0.00	0.00	0.00	0.00	0.00	0.00	0.00
9-11	0.00	0.00	0.00	0.00	0.00	0.00	0.00	0.00	0.00	0.00	0.00
>11	0.00	0.00	0.00	0.00	0.00	0.00	0.00	0.00	0.00	0.00	0.00
	47.35	47.45	5.61	2.04	1.02	1.02	.51	0.00	0.00	0.00	0.00

TOTAL NO. OF OBSERVATIONS USED IN THIS TABLE = 196.

SPEED (M/SEC)	0.00-0.05	0.05-0.10	0.10-0.15	0.15-0.20	0.20-0.25	0.25-0.30	0.30-0.35	0.35-0.40	0.40-0.45	>0.45	TOTAL
<1	11.25	0.00	0.00	6.25	6.75	0.00	6.25	0.00	0.00	0.00	100.00
1-3	53.00	14.62	7.69	2.31	.77	1.54	0.00	0.00	0.00	0.00	100.00
3-4	2.67	94.74	2.63	0.00	0.00	0.00	0.00	0.00	0.00	0.00	100.00
5-9	0.00	100.00	0.00	0.00	0.00	0.00	0.00	0.00	0.00	0.00	100.00
7-9	0.00	0.00	0.00	0.00	0.00	0.00	0.00	0.00	0.00	0.00	0.00
9-11	0.00	0.00	0.00	0.00	0.00	0.00	0.00	0.00	0.00	0.00	0.00
>11	0.00	0.00	0.00	0.00	0.00	0.00	0.00	0.00	0.00	0.00	0.00



FREQUENCY DISTRIBUTIONS OF THE LATERAL COMPONENT TURBULENCE INTENSITY  
FOR THE ROUGH SECTOR AT THE SEA-TAC 27.0 m LEVEL BY WIND SPEED

SPFED (M/SEC)	0.00-0.05	0.05-0.10	0.10-0.15	0.15-0.20	0.20-0.25	0.25-0.30	0.30-0.35	0.35-0.40	0.40-0.45	>0.45	TOTAL
<1	.16	.38	.19	.38	.19	.38	0.00	.19	0.00	.38	2.28
1-4	1.71	3.98	10.63	11.76	6.45	3.98	3.47	1.52	.57	1.33	45.35
3-6	.19	1.33	10.06	11.76	7.21	1.71	.19	0.00	0.00	.38	32.83
5-7	.19	.57	3.80	6.26	3.47	.19	0.00	0.00	.19	0.00	14.61
7-9	0.00	.38	1.33	1.71	.57	0.00	0.00	0.00	0.00	0.00	3.98
9-11	0.00	0.00	.57	.38	0.10	0.00	0.00	0.00	0.00	0.00	.95
>11	0.00	0.00	0.00	0.00	0.10	0.00	0.00	0.00	0.00	0.00	0.00
	2.28	6.64	26.57	32.26	17.14	6.26	3.61	1.71	.76	2.09	

TOTAL NO. OF OBSERVATIONS USED IN THIS TABLE = 527.

SPFED (M/SEC)	0.00-0.05	0.05-0.10	0.10-0.15	0.15-0.20	0.20-0.25	0.25-0.30	0.30-0.35	0.35-0.40	0.40-0.45	>0.45	TOTAL
<1	8.37	16.67	8.33	16.67	8.33	16.67	0.00	8.33	0.00	16.67	100.00
1-4	3.77	8.79	23.63	25.94	14.23	8.79	7.57	3.35	1.26	2.93	100.00
3-6	.58	4.05	10.64	35.84	21.97	5.20	.58	0.00	0.00	1.16	100.00
5-7	1.30	3.90	25.97	42.86	23.38	1.30	0.00	0.00	1.30	0.00	100.00
7-9	0.00	9.52	33.33	42.86	14.29	0.00	0.00	0.00	0.00	0.00	100.00
9-11	0.00	0.00	60.00	40.00	0.00	0.00	0.00	0.00	0.00	0.00	100.00
>11	0.00	0.00	0.00	0.00	0.10	0.00	0.00	0.00	0.00	0.00	0.00

FREQUENCY DISTRIBUTIONS OF THE VERTICAL COMPONENT TURBULENCE INTENSITY FOR  
THE ROUGH SECTOR AT THE SEA-TAC 27.0 M LEVEL BY WIND SPEED

SPEED (M/SEC)	0.00-0.05	0.05-0.10	0.10-0.15	0.15-0.20	0.20-0.25	0.25-0.30	0.30-0.35	0.35-0.40	0.40-0.45	>0.45	TOTAL
<1	.95	.38	0.00	.19	0.00	.19	0.00	0.00	0.00	.38	2.09
1-4	5.32	7.79	9.89	9.32	4.75	3.80	2.09	.57	.76	1.14	45.44
3-6	.74	2.09	13.50	12.93	3.23	.38	0.00	0.00	0.00	0.00	32.89
5-7	.10	.57	7.60	5.51	.19	.19	.19	.19	0.00	0.00	14.64
7-9	0.00	0.00	2.65	.95	.19	.19	0.00	0.00	0.00	0.00	3.99
9-11	0.00	0.00	.57	.19	.19	0.00	0.00	0.00	0.00	0.00	.95
>11	0.00	0.00	0.00	0.00	0.00	0.00	0.00	0.00	0.00	0.00	0.00
TOTAL	7.72	10.84	34.22	29.09	8.54	4.75	2.28	.76	.76	1.52	0.00

TOTAL NO. OF OBSERVATIONS USED IN THIS TABLE = 526.

SPEED (M/SEC)	0.00-0.05	0.05-0.10	0.10-0.15	0.15-0.20	0.20-0.25	0.25-0.30	0.30-0.35	0.35-0.40	0.40-0.45	>0.45	TOTAL
<1	45.45	18.18	0.00	9.09	0.10	9.09	0.00	0.00	0.00	18.18	100.00
1-4	11.72	17.15	21.76	20.50	10.46	6.37	4.60	1.26	1.67	2.51	100.00
3-6	2.31	6.36	41.04	39.31	9.53	1.16	0.00	0.00	0.00	0.00	100.00
5-7	1.30	3.90	51.95	37.66	1.30	1.30	1.30	1.30	0.00	0.00	100.00
7-9	0.00	0.00	66.67	23.81	4.76	4.76	0.00	0.00	0.00	0.00	100.00
9-11	0.00	0.00	60.00	20.00	20.10	0.00	0.00	0.00	0.00	0.00	100.00
>11	0.00	0.00	0.00	0.00	0.10	0.00	0.00	0.00	0.00	0.00	0.00
TOTAL	66.67	66.67	66.67	66.67	66.67	66.67	66.67	66.67	66.67	66.67	66.67

FREQUENCY DISTRIBUTIONS OF THE LONGITUDINAL COMPONENT TURBULENCE INTENSITY  
FOR THE SMOOTH SECTOR AT THE SEA-TAC 27.0 m LEVEL BY WIND SPEED

SPEED (m/SEC)	0.00-0.05	0.05-0.10	0.10-0.15	0.15-0.20	0.20-0.25	0.25-0.30	0.30-0.35	0.35-0.40	0.40-0.45	TOTAL
<1	0.00	1.00	2.00	1.50	.50	0.00	0.00	0.00	0.00	1.50
1-1	2.00	19.00	22.00	9.00	3.50	1.00	1.00	1.00	0.00	1.50
3-5	.50	6.00	9.50	5.50	1.50	0.00	0.00	.50	0.00	0.00
5-7	0.00	1.50	4.50	2.50	.50	0.00	0.00	0.00	0.00	0.00
7-9	0.00	0.00	1.00	0.00	0.00	0.00	0.00	0.00	0.00	1.00
9-11	0.00	0.00	0.00	0.00	0.00	0.00	0.00	0.00	0.00	0.00
>11	0.00	0.00	0.00	0.00	0.00	0.00	0.00	0.00	0.00	0.00
	2.50	27.50	19.00	10.50	6.00	1.00	1.00	1.50	0.00	3.00

TOTAL NO. OF OBSERVATIONS USED IN THIS TABLE = 200.

SPEED (m/SEC)	0.00-0.05	0.05-0.10	0.10-0.15	0.15-0.20	0.20-0.25	0.25-0.30	0.30-0.35	0.35-0.40	0.40-0.45	TOTAL
<1	0.00	15.38	30.77	23.08	7.59	0.00	0.00	0.00	0.00	23.08
1-1	3.12	11.67	16.67	15.00	5.93	1.67	1.67	1.67	0.00	2.50
3-5	2.12	25.53	40.43	23.40	6.38	0.00	0.00	2.13	0.00	0.00
5-7	0.00	16.67	50.00	27.78	5.56	0.00	0.00	0.00	0.00	100.00
7-9	0.00	0.00	100.00	0.00	0.00	0.00	0.00	0.00	0.00	100.00
9-11	0.00	0.00	0.00	0.00	0.00	0.00	0.00	0.00	0.00	0.00
>11	0.00	0.00	0.00	0.00	0.00	0.00	0.00	0.00	0.00	0.00

FREQUENCY DISTRIBUTIONS OF THE LATERAL COMPONENT TURBULENCE INTENSITY FOR  
THE SMOOTH SECTOR AT THE SEA-FAC 27.0 m LEVEL BY WIND SPEED

SPEED (M/SEC)	0.00-0.05	0.05-0.10	0.10-0.15	0.15-0.20	0.20-0.25	0.25-0.30	0.30-0.35	0.35-0.40	0.40-0.45	>0.45	TOTAL
<1	0.00	1.50	1.00	1.00	0.00	0.00	0.00	0.00	0.00	1.50	6.50
1-3	5.50	21.50	18.50	8.00	2.50	2.00	0.00	1.00	.50	.50	60.00
3-5	1.00	10.00	8.00	3.50	1.00	0.00	0.00	0.00	0.00	0.00	23.50
5-7	.50	6.00	2.00	.50	0.00	0.00	0.00	0.00	0.00	0.00	9.00
7-9	0.00	.50	0.00	.50	0.00	0.00	0.00	0.00	0.00	0.00	1.00
9-11	0.00	0.00	0.00	0.00	0.00	0.00	0.00	0.00	0.00	0.00	0.00
>11	0.00	0.00	0.00	0.00	0.00	0.00	0.00	0.00	0.00	0.00	0.00
	7.00	19.50	30.00	13.50	4.50	2.00	0.00	1.00	.50	2.00	

TOTAL NO. OF OBSERVATIONS USED IN THIS TABLE = 200.											TOTAL
SPEED (M/SEC)	0.00-0.05	0.05-0.10	0.10-0.15	0.15-0.20	0.20-0.25	0.25-0.30	0.30-0.35	0.35-0.40	0.40-0.45	>0.45	TOTAL
<1	0.00	23.00	23.00	15.30	15.30	0.00	0.00	0.00	0.00	23.00	100.00
1-3	9.17	35.63	30.83	13.33	4.17	3.33	0.00	1.67	.83	.83	100.00
3-5	4.24	42.55	34.04	14.89	4.24	0.00	0.00	0.00	0.00	0.00	100.00
5-7	5.54	66.67	22.22	5.56	0.00	0.00	0.00	0.00	0.00	0.00	100.00
7-9	0.00	50.00	6.00	50.00	0.00	0.00	0.00	0.00	0.00	0.00	100.00
9-11	0.00	0.00	0.00	0.00	0.00	0.00	0.00	0.00	0.00	0.00	0.00
>11	0.00	0.00	0.00	0.00	0.00	0.00	0.00	0.00	0.00	0.00	0.00

FREQUENCY DISTRIBUTIONS OF THE VERTICAL COMPONENT TURBULENCE INTENSITY FOR  
THE SMOOTH SECTOR AT THE SEA-TAC 27.0 m LEVEL BY WIND SPEED

SPEED (M/SEC)	0.00-0.05	0.05-0.10	0.10-0.15	0.15-0.20	0.20-0.25	0.25-0.30	0.30-0.35	0.35-0.40	0.40-0.45	>0.45	TOTAL
<1	2.07	.52	.52	0.00	0.00	0.00	0.00	0.00	0.00	1.04	4.15
1-4	25.01	19.69	11.40	1.55	.52	0.00	0.00	0.00	0.00	1.55	61.14
3-6	3.61	9.33	16.36	1.04	0.10	0.00	0.00	0.00	0.00	0.00	24.35
5-7	0.00	7.25	2.07	0.00	0.10	0.00	0.00	0.00	0.00	0.00	9.33
7-9	0.00	.52	.52	0.00	0.00	0.00	0.00	0.00	0.00	0.00	1.04
9-11	0.00	0.00	0.00	0.00	0.10	0.00	0.00	0.00	0.00	0.00	0.00
>11	0.00	0.00	0.00	0.00	0.10	0.00	0.00	0.00	0.00	0.00	0.00
	31.61	37.31	24.87	2.59	.52	0.00	0.00	0.00	0.00	2.59	

TOTAL NO. OF OBSERVATIONS USED IN THIS TABLE = 193.

SPEED (M/SEC)	0.00-0.05	0.05-0.10	0.10-0.15	0.15-0.20	0.20-0.25	0.25-0.30	0.30-0.35	0.35-0.40	0.40-0.45	>0.45	TOTAL
<1	50.00	12.50	12.50	0.00	0.10	0.00	0.00	0.00	0.00	25.00	100.00
1-4	42.37	12.20	18.64	2.54	.85	0.00	0.00	0.00	0.00	2.54	100.00
3-6	14.89	18.30	42.55	4.26	0.00	0.00	0.00	0.00	0.00	0.00	100.00
5-7	0.00	77.78	22.22	0.00	0.00	0.00	0.00	0.00	0.00	0.00	100.00
7-9	0.00	50.00	50.00	0.00	0.00	0.00	0.00	0.00	0.00	0.00	100.00
9-11	0.00	0.00	0.00	0.00	0.00	0.00	0.00	0.00	0.00	0.00	0.00
>11	0.00	0.00	0.00	0.00	0.10	0.00	0.00	0.00	0.00	0.00	0.00

## APPENDIX F

### AVERAGE TURBULENCE LENGTH SCALES

In Appendix F, average length scales are presented for each turbulence component. As in Appendices D and E, the tabulations are organized by site and level, as well as component. The average length scales presented have been tabulated for all observations with wind speeds of 0.5 m/s or greater in which there were 512 consecutive samples. The length scales were computed from the integral time scale and mean wind speed using Taylor's hypothesis, (for details of the computation see Chapter 10).

For each wind speed and direction combination the tabulated value is the length scale in m. The length scale values contained in these tables have not been corrected for length of observation as suggested in Chapter 10. Thus, to obtain more realistic estimates of the actual length scales the tabulated values should be multiplied by the appropriate value of  $A_y$  given in Table 21 in Chapter 10.

As in Appendix D, marginal values in the tables give average length scales for each direction and wind speed independent of the other factor.

Following the tabulation of length scales for each instrument is a table which gives the number of values averaged in each category.

AVERAGE LONGITUDINAL COMPONENT TURBULENCE LENGTH SCALES AT THE LAKE  
UNION 6.9 m LEVEL BY WIND SPEED AND DIRECTION

Dir.	(D.F.S.)	<1	1-3	3-5	5-7	7-9	9-11	>11	TOTAL
N		7.126	14.257	31.148	0.000	0.000	0.000	0.000	15.839
NNE		11.515	18.010	30.560	41.367	0.000	0.000	0.000	19.609
NE		6.824	16.643	27.727	0.000	0.000	0.000	0.000	17.368
NNE		8.104	14.411	13.500	0.000	0.000	0.000	0.000	12.325
E		8.147	10.925	0.000	0.000	0.000	0.000	0.000	9.113
ESE		8.994	13.422	0.000	0.000	0.000	0.000	0.000	11.240
SE		9.044	12.847	0.000	0.000	0.000	0.000	0.000	11.139
SSE		9.211	20.647	22.450	0.000	0.000	0.000	0.000	18.147
S		11.907	22.349	16.240	42.648	30.670	0.000	0.000	27.817
SSW		9.418	23.222	34.213	42.308	46.366	56.650	0.000	29.430
SW		4.274	14.093	34.953	56.100	0.000	0.000	0.000	21.852
SSW		7.004	21.244	25.400	0.000	0.000	0.000	0.000	20.263
W		0.240	25.496	36.300	0.000	0.000	0.000	0.000	25.860
WSW		8.100	21.447	40.250	0.000	0.000	0.000	0.000	25.296
W		12.113	26.039	41.642	52.480	67.675	59.500	0.000	37.735
WSW		4.162	19.609	41.315	54.711	45.860	0.000	0.000	30.592
W		4.300	14.476	35.507	47.257	54.910	57.575	0.000	

AVERAGE LATERAL COMPONENT TURBULENCE LENGTH SCALES AT THE LAKE UNION  
6.9 M LEVEL BY WIND SPEED AND DIRECTION

DIRM. (DEGS.)	<1	1-3	3-5	5-7	7-9	9-11	>11	TOTAL
N	7.003	14.404	36.015	0.000	0.000	0.000	0.000	16.802
NNE	9.104	18.051	29.151	46.167	0.000	0.000	0.000	19.210
NE	9.241	16.757	25.480	0.000	0.000	0.000	0.000	15.788
NNE	7.878	13.024	11.000	0.000	0.000	0.000	0.000	11.161
E	7.557	9.383	0.000	0.000	0.000	0.000	0.000	8.213
ESE	8.201	11.070	0.000	0.000	0.000	0.000	0.000	9.740
SE	7.683	12.634	0.000	0.000	0.000	0.000	0.000	10.410
SSE	9.237	15.661	16.175	0.000	0.000	0.000	0.000	14.311
S	10.746	14.041	25.249	27.000	81.850	0.000	0.000	22.195
SSW	10.582	22.043	30.797	36.611	41.350	61.650	0.000	26.968
SW	9.067	21.539	26.843	24.700	1.000	0.000	0.000	21.291
WSW	7.225	19.950	24.070	0.000	0.000	0.000	0.000	18.961
W	11.640	20.076	33.960	0.000	0.000	0.000	0.000	21.672
WNW	6.475	24.821	46.067	0.000	1.000	0.000	0.000	26.864
WW	9.436	25.555	37.421	48.580	46.875	111.000	0.000	34.271
WNW	6.940	18.689	28.317	45.096	34.375	0.000	0.000	24.832
W	8.740	14.647	29.039	38.072	41.806	86.325	0.000	

AVERAGE VERTICAL COMPONENT TURBULENCE LENGTH SCALES AT THE LAKE UNION  
6.9 M LEVEL BY WIND SPEED AND DIRECTION

DIR.	SECS.	1-3	3-5	5-7	7-9	9-11	>11	TOTAL
N	4.484	7.674	15.805	0.000	0.010	0.000	0.000	8.053
NNE	4.182	7.932	11.480	9.920	0.010	0.000	0.000	8.098
NE	4.427	7.660	0.382	0.000	0.030	0.000	0.000	6.994
NNE	4.001	7.227	4.272	0.680	0.000	0.000	0.000	6.111
E	4.407	6.208	0.000	0.000	0.010	0.000	0.000	4.805
ESE	4.377	7.163	6.660	0.000	0.010	0.000	0.000	5.751
SE	5.449	6.049	0.000	0.000	0.010	0.000	0.000	6.462
SSE	4.477	7.671	8.422	0.000	0.010	0.000	0.000	7.138
S	3.006	6.788	10.449	11.267	11.110	0.000	0.000	9.534
SSW	4.208	9.120	10.643	10.494	9.915	10.495	0.000	9.754
SW	3.467	9.254	10.441	11.150	0.010	0.000	0.000	8.760
WSW	3.495	8.452	7.539	0.000	6.010	0.000	0.000	7.735
W	5.174	9.456	14.049	0.000	0.010	0.000	0.000	9.867
WNW	4.710	10.814	14.258	0.000	0.010	0.000	0.000	10.980
W	5.400	6.874	11.281	14.156	16.219	9.340	0.000	10.526
WNW	3.456	9.057	15.026	26.294	16.211	0.000	0.000	13.189
W	4.441	6.301	11.685	15.728	14.812	9.918	0.000	0.000

NUMBER OF OBSERVATIONS AVERAGED IN THE LAKE UNION 6.9 m LENGTH  
SCALE TABLES BY WIND SPEED AND DIRECTION

DIRN.	1-1	1-7	1-5	5-7	7-9	9-11	>11	TOTAL
N	27,000	110,000	27,000	0,000	0,000	0,000	0,000	170,000
NNE	24,000	154,000	15,000	3,000	0,000	0,000	0,000	217,000
NW	41,000	127,000	15,000	0,000	0,000	0,000	0,000	183,000
ENE	20,000	70,000	1,000	0,000	0,000	0,000	0,000	59,000
E	15,000	0,000	0,000	0,000	0,000	0,000	0,000	23,000
ESW	22,000	21,000	0,000	0,000	0,000	0,000	0,000	45,000
SE	14,000	17,000	0,000	0,000	0,000	0,000	0,000	31,000
SSE	10,000	0,000	4,000	0,000	0,000	0,000	0,000	49,000
S	14,000	125,000	124,000	25,000	2,000	0,000	0,000	340,000
SSW	11,000	140,000	130,000	20,000	2,000	2,000	0,000	326,000
SW	21,000	0,000	30,000	1,000	0,000	0,000	0,000	140,000
WSW	0,000	40,000	10,000	0,000	0,000	0,000	0,000	64,000
W	0,000	40,000	10,000	0,000	0,000	0,000	0,000	60,000
WNW	0,000	10,000	0,000	0,000	0,000	0,000	0,000	20,000
WV	0,000	40,000	50,000	10,000	0,000	2,000	0,000	124,000
WSW	0,000	110,000	40,000	24,000	0,000	0,000	0,000	222,000
	242,000	1220,000	510,000	55,000	16,000	4,000	0,000	

AVERAGE LONGITUDINAL COMPONENT TURBULENCE LENGTH SCALES AT THE LAKE  
UNION 12.6 + 17.1 m LEVELS BY WIND SPEED AND DIRECTION

DIRN. (DEGS.)	<1	1-3	3-5	5-7	7-9	9-11	>11	TOTAL
N	6.979	16.394	30.086	72.000	69.350	0.000	0.000	19.498
<del>NNE</del>	9.409	17.840	39.434	50.900	0.000	0.000	0.000	21.204
NE	8.264	19.032	32.642	0.000	0.000	0.000	0.000	18.427
ENE	7.677	14.881	24.100	0.000	0.000	0.000	0.000	13.246
E	9.911	14.119	25.600	0.000	0.000	0.000	0.000	13.104
ESE	7.800	15.926	31.500	0.000	0.000	0.000	0.000	15.249
SE	9.455	14.559	21.600	0.000	0.000	0.000	0.000	12.416
SSE	10.400	21.101	29.790	0.000	0.000	0.000	0.000	20.534
S	10.190	23.407	38.701	53.076	40.400	0.000	0.000	33.311
SSW	12.955	25.421	38.027	46.355	44.570	102.100	66.400	33.985
SW	8.664	19.550	41.394	39.775	0.000	0.000	0.000	24.173
WSW	8.714	23.256	33.114	0.000	0.000	0.000	0.000	22.803
W	10.500	23.264	40.300	0.000	0.000	0.000	0.000	21.785
WNW	17.550	28.600	32.350	0.000	0.000	0.000	0.000	27.738
NW	9.187	31.012	42.898	53.908	70.950	0.000	0.000	39.142
NNW	10.920	17.448	36.989	56.474	56.050	0.000	0.000	30.472
	9.179	20.325	37.803	53.077	51.779	102.100	66.400	

AVERAGE LATERAL COMPONENT TURBULENCE LENGTH SCALES AT THE LAKE UNION  
12.6 + 17.1 m LEVELS BY WIND SPEED AND DIRECTION

DIREN. (DEGS.)	<1	1-3	3-5	5-7	7-9	9-11	>11	TOTAL
N	6.383	13.278	28.054	43.700	36.150	0.000	0.000	15.639
NNE	9.164	15.958	31.609	36.467	0.000	0.000	0.000	18.268
NE	7.991	16.628	25.021	0.000	0.000	0.000	0.000	15.843
ENE	8.492	12.923	18.750	0.000	0.000	0.000	0.000	11.924
E	8.733	13.713	6.800	0.000	0.000	0.000	0.000	11.723
ESE	7.489	10.044	20.633	0.000	0.000	0.000	0.000	10.285
SE	7.205	14.218	32.100	0.000	0.000	0.000	0.000	11.573
SSE	8.371	16.222	16.270	0.000	0.000	0.000	0.000	15.112
S	7.060	19.411	25.656	29.327	48.016	0.000	0.000	23.371
SSW	8.209	21.305	30.320	40.225	35.057	50.200	41.600	27.670
SW	9.476	20.713	31.410	27.275	0.000	0.000	0.000	22.240
WSW	9.343	19.054	25.171	0.000	0.000	0.000	0.000	18.649
W	9.588	22.514	26.500	0.000	0.000	0.000	0.000	20.439
WNW	9.500	16.575	19.350	0.000	0.000	0.000	0.000	26.538
W	8.800	25.469	33.873	41.892	60.050	0.000	0.000	31.386
WNW	13.400	15.525	30.121	50.084	92.775	0.000	0.000	27.280
WNW	8.445	17.551	28.665	38.205	52.996	50.200	41.600	

AVERAGE VERTICAL COMPONENT TURBULENCE LENGTH SCALES AT THE LAKE UNION  
12.6 + 17.1 m LEVELS BY WIND SPEED AND DIRECTION

DIRN. (DEGS.)	<1	1-3	3-5	5-7	7-9	9-11	>11	TOTAL
N	5.287	9.688	14.139	18.210	16.435	0.000	0.000	10.194
NNF	5.262	10.329	14.687	10.430	0.000	0.000	0.000	10.572
NE	5.316	10.341	11.595	0.000	0.000	0.000	0.000	9.453
ENE	5.480	9.156	11.980	0.000	0.000	0.000	0.000	8.242
E	4.879	9.236	10.540	0.000	0.000	0.000	0.000	7.778
ESE	5.380	9.602	13.654	0.000	0.000	0.000	0.000	8.921
SF	6.917	10.094	6.850	0.000	0.000	0.000	0.000	8.468
SSE	6.024	10.921	12.150	0.000	0.000	0.000	0.000	10.363
S	5.472	11.032	13.535	15.483	16.877	0.000	0.000	12.557
SSW	4.925	11.356	13.537	14.675	15.019	12.340	28.810	12.625
SW	6.118	10.925	13.114	14.503	0.000	0.000	0.000	11.038
WSW	7.182	12.919	10.010	0.000	0.000	0.000	0.000	11.277
W	8.030	12.973	11.330	0.000	0.000	0.000	0.000	12.042
WNW	5.240	13.143	12.465	0.000	0.000	0.000	0.000	12.070
NW	6.141	12.943	17.917	20.252	21.998	0.000	0.000	15.983
NNW	5.131	11.922	16.271	24.073	19.588	0.000	0.000	15.037
	5.754	10.903	14.038	17.352	17.600	12.340	28.810	

NUMBER OF OBSERVATIONS AVERAGED IN THE LAKE UNION 12.6 + 17.1 m  
LENGTH SCALE TABLES BY WIND SPEED AND DIRECTION

DIRN. (DEGS.)	<1	1-3	3-5	5-7	7-9	9-11	>11	TOTAL
R	29.000	146.000	28.000	8.000	2.000	0.000	0.000	213.000
N-E	22.000	139.000	35.000	3.000	0.000	0.000	0.000	199.000
NE	33.000	104.000	19.000	0.000	0.000	0.000	0.000	160.000
E-N-E	13.000	31.000	2.000	0.000	0.000	0.000	0.000	46.000
E	9.000	16.000	1.000	0.000	0.000	0.000	0.000	26.000
E-S-E	9.000	27.000	3.000	0.000	0.000	0.000	0.000	39.000
SE	22.000	22.000	1.000	0.000	0.000	0.000	0.000	45.000
S-S-E	13.000	69.000	10.000	0.000	0.000	0.000	0.000	92.000
S	10.000	166.000	137.000	55.000	7.000	0.000	0.000	375.000
S-S-W	11.000	121.000	148.000	40.000	7.000	1.000	1.000	329.000
SW	16.000	82.000	31.000	4.000	0.000	0.000	0.000	131.000
WSW	14.000	48.000	17.000	0.000	0.000	0.000	0.000	79.000
W	8.000	36.000	2.000	0.000	0.000	0.000	0.000	46.000
WNW	2.000	14.000	2.000	0.000	0.000	0.000	0.000	16.000
WN	8.000	34.000	52.000	22.000	4.000	0.000	0.000	108.000
WNW	10.000	81.000	43.000	31.000	4.000	0.000	0.000	169.000
	227.000	1136.000	531.000	153.000	24.000	1.000	1.000	

AVERAGE LONGITUDINAL COMPONENT TURBULENCE LENGTH SCALES AT THE LAKE  
UNION 24.8 m LEVEL BY WIND SPEED AND DIRECTION

DIRN. (DEGS.)	<1	1-3	3-5	5-7	7-9	9-11	>11	TOTAL
N	8.733	18.860	32.105	67.013	0.010	0.000	0.000	25.008
NNE	10.662	18.446	38.149	40.733	36.600	0.000	0.000	22.797
NE	9.526	20.337	37.140	61.040	0.000	0.000	0.000	24.946
ENE	6.174	17.147	31.200	108.400	0.000	0.000	0.000	21.105
E	10.763	19.387	28.739	52.400	0.010	0.000	0.000	20.013
ESE	10.300	24.173	30.922	59.500	0.000	0.000	0.000	27.154
SE	7.555	20.990	32.510	0.000	0.000	0.000	0.000	20.447
SSE	6.233	21.873	40.654	38.620	0.010	0.000	0.000	26.596
S	11.529	25.749	41.547	52.766	74.064	56.333	0.000	40.818
SSW	9.875	23.581	41.599	55.800	62.757	63.450	156.400	40.196
SW	10.617	20.726	39.952	51.225	0.010	0.000	0.000	25.078
WSW	8.191	21.606	38.879	60.100	0.010	0.000	0.000	24.257
W	9.900	20.316	0.000	0.000	0.000	0.000	0.000	17.816
WSW	8.400	19.933	37.700	0.000	0.000	0.000	0.000	19.988
W	10.300	31.650	35.821	23.784	0.000	0.000	0.000	29.823
WNW	9.300	23.488	38.081	53.206	86.430	62.900	0.000	37.466
WNW	9.455	21.356	36.779	52.551	71.243	60.956	156.400	

AVERAGE LATERAL COMPONENT TURBULENCE LENGTH SCALES AT THE LAKE UNION  
24.8 m LEVEL BY WIND SPEED AND DIRECTION

DIRN. (DEGS.)	<1	1-3	3-5	5-7	7-9	9-11	>11	TOTAL
N	6.424	15.583	29.715	76.267	0.300	0.000	0.000	23.058
NNE	10.605	17.173	28.409	45.967	49.300	0.000	0.000	19.862
NE	8.375	16.814	29.249	41.580	0.300	0.000	0.000	20.052
ENE	8.573	18.647	16.831	120.800	0.900	0.000	0.000	19.473
E	8.475	14.814	30.383	35.900	0.300	0.000	0.000	16.934
ESE	6.680	13.847	13.200	20.400	0.900	0.000	0.000	13.358
SE	6.482	14.908	23.260	0.000	0.300	0.000	0.000	14.828
SSE	8.967	15.418	30.697	20.140	0.300	0.000	0.000	19.214
S	6.814	14.574	27.917	32.505	35.695	81.700	0.000	26.968
SSW	7.538	21.649	29.859	39.231	34.129	31.650	35.600	28.976
SW	9.744	20.088	32.624	25.650	0.300	0.000	0.000	21.926
WSW	8.764	22.734	26.271	22.500	0.300	0.000	0.000	21.023
W	8.403	17.200	0.000	0.000	0.000	0.000	0.000	16.748
WSW	9.500	25.717	18.700	0.000	0.000	0.000	0.000	22.029
W	11.143	27.192	21.244	12.142	0.000	0.000	0.000	20.209
WSW	10.263	21.118	28.670	49.897	67.740	126.400	0.000	32.326
W	8.658	18.377	28.324	38.560	41.400	69.389	35.600	

AVERAGE VERTICAL COMPONENT TURBULENCE LENGTH SCALES AT THE LAKE UNION  
24.8 m LEVEL BY WIND SPEED AND DIRECTION

DIRN. (DEGS.)	<1	1-3	3-5	5-7	7-9	9-11	>11	TOTAL
N	5.912	17.738	17.121	22.429	0.000	0.000	0.000	13.979
NNE	6.526	11.521	16.700	15.120	16.140	0.000	0.000	12.367
NE	6.322	11.922	16.230	28.974	0.000	0.000	0.000	12.989
NNE	7.617	10.480	15.119	49.100	0.000	0.000	0.000	11.787
E	6.065	9.392	26.698	30.100	0.000	0.000	0.000	12.453
ESE	6.618	14.794	14.468	34.893	0.000	0.000	0.000	15.536
SE	5.141	11.858	15.010	0.000	0.000	0.000	0.000	11.152
SSE	4.992	13.634	14.773	14.958	0.010	0.000	0.000	13.609
S	5.997	14.310	17.479	16.721	24.065	19.700	0.000	16.309
SSW	5.619	13.269	17.857	20.093	20.857	20.575	23.720	16.896
SW	7.480	13.633	14.579	20.778	0.000	0.000	0.000	13.301
WSW	5.988	12.858	16.703	19.710	0.000	0.000	0.000	12.609
W	6.148	12.774	0.000	0.000	0.000	0.000	0.000	11.634
WNW	7.777	16.362	15.900	0.000	0.000	0.000	0.000	14.792
W	6.761	16.317	22.505	12.044	0.000	0.000	0.000	17.042
NNW	6.949	14.348	20.254	23.144	24.082	63.110	0.000	18.860
N	6.525	12.779	17.553	19.313	22.678	29.736	23.720	

NUMBER OF OBSERVATIONS AVERAGED IN THE LAKE UNION 24.8 m LENGTH  
SCALE TABLES BY WIND SPEED AND DIRECTION

DIR. (DEGS.)	<1	1-3	3-5	5-7	7-9	9-11	>11	TOTAL
N	21,000	115,000	59,000	15,000	0,000	0,000	0,000	210,000
NNE	21,000	151,000	55,000	3,000	1,000	0,000	0,000	231,000
NE	20,000	123,000	57,000	5,000	0,000	0,000	0,000	205,000
ENE	11,000	49,000	16,000	2,000	0,000	0,000	0,000	78,000
E	8,000	17,000	6,000	1,000	0,100	0,000	0,000	32,000
ESE	4,000	15,000	4,000	3,000	0,000	0,000	0,000	26,000
SE	11,000	39,000	10,000	0,000	0,000	0,000	0,000	60,000
SSE	6,000	97,000	37,000	5,000	0,100	0,000	0,000	145,000
S	7,000	109,000	156,000	80,000	22,100	3,000	0,000	377,000
SSW	8,000	93,000	143,000	58,000	21,100	4,000	1,000	328,000
SW	18,000	77,000	33,000	4,000	0,100	0,000	0,000	132,000
WSW	11,000	35,000	14,000	1,000	0,100	0,000	0,000	61,000
W	6,000	19,000	0,000	0,000	0,100	0,000	0,000	25,000
WNW	3,000	12,000	2,000	0,000	0,000	0,000	0,000	17,000
NW	7,000	26,000	34,000	19,000	0,000	0,000	0,000	86,000
NNW	8,000	65,000	69,000	35,000	10,000	2,000	0,000	189,000
	170,000	1042,000	695,000	231,000	54,100	9,000	1,000	

AVERAGE LONGITUDINAL COMPONENT TURBULENCE LENGTH SCALES AT THE LAKE  
UNION 48.2 m LEVEL BY WIND SPEED AND DIRECTION

DIRN. (DEGS.)	<1	1-3	3-5	5-7	7-9	9-11	>11	TOTAL
N	8.413	17.619	34.490	47.814	71.300	0.000	0.000	26.228
NNE	14.440	18.644	35.517	48.350	0.000	0.000	0.000	25.522
NE	10.157	23.226	33.930	49.525	0.000	0.000	0.000	27.842
ENE	5.280	22.132	36.040	46.067	0.000	0.000	0.000	26.049
E	8.500	22.173	17.000	86.400	0.000	0.000	0.000	25.114
ESE	11.400	20.200	0.000	0.000	73.500	0.000	251.400	70.133
SF	16.740	25.730	62.700	28.100	0.000	0.000	14.200	34.870
SSE	8.467	23.980	37.430	42.600	69.600	0.000	185.600	36.156
S	8.400	20.020	44.810	57.302	70.811	99.329	109.950	57.936
SSW	6.300	20.700	47.920	64.811	81.389	81.914	97.933	53.375
SW	14.275	24.462	41.750	60.025	68.500	0.000	0.000	35.176
WSW	7.000	24.032	42.441	47.250	0.000	0.000	0.000	28.390
W	8.300	23.264	0.000	0.000	0.000	0.000	0.000	17.907
WSW	9.317	24.733	48.600	0.000	0.000	0.000	0.000	21.300
W	12.360	24.388	38.311	63.591	0.000	0.000	0.000	36.759
WNW	10.250	21.016	38.010	53.479	63.311	48.100	0.000	36.291
W	9.760	22.129	40.638	57.825	72.189	92.404	120.613	

AVERAGE LATERAL COMPONENT TURBULENCE LENGTH SCALES AT THE LAKE UNION  
48.2 M LEVEL BY WIND SPEED AND DIRECTION

DIR. (CGS.)	<1	1-3	3-5	5-7	7-9	9-11	>11	TOTAL
N	8.432	17.483	30.085	47.462	28.550	0.000	0.000	24.431
NNE	8.600	17.163	35.497	28.983	0.000	0.000	0.000	23.118
NE	6.443	14.716	26.743	29.825	0.000	0.000	0.000	21.711
NNE	9.470	23.345	24.838	35.600	0.000	0.000	0.000	21.521
E	16.700	24.000	14.500	13.500	0.000	0.000	0.000	21.771
ESE	3.400	11.633	0.000	0.000	33.760	0.000	271.000	57.250
SE	11.750	16.316	23.286	10.600	0.000	0.000	10.600	17.178
SE	10.100	14.486	24.411	30.200	73.330	0.000	78.000	27.137
S	13.333	24.520	37.635	24.666	27.130	43.300	84.300	31.138
SSW	10.270	24.344	32.477	43.507	52.737	74.143	110.033	36.312
SW	14.375	21.272	37.495	30.494	26.467	0.000	0.000	27.350
WSW	12.850	24.634	25.635	51.400	0.700	0.000	0.000	23.594
W	9.446	17.872	0.000	0.000	0.000	0.000	0.000	14.868
WNW	6.200	21.400	19.300	0.600	0.700	0.000	0.000	14.315
W	10.060	22.458	32.716	38.464	0.300	0.000	0.000	28.377
WNW	5.783	14.517	27.461	39.606	49.844	31.400	0.000	27.816
	0.572	13.744	31.207	35.064	36.141	51.460	107.288	

AVERAGE VERTICAL COMPONENT TURBULENCE LENGTH SCALES AT THE LAKE UNION  
48.2 m LEVEL BY WIND SPEED AND DIRECTION

Dir. (DEGS.)	cl	1-3	3-5	5-7	7-9	9-11	>11	TOTAL
N	4.461	14.359	22.237	26.205	12.810	0.000	0.000	17.479
NNE	6.122	14.410	24.274	21.277	0.000	0.000	0.000	17.457
NE	10.770	15.471	23.291	23.063	0.000	0.000	0.000	17.573
NNE	4.954	12.675	25.561	13.360	0.000	0.000	0.000	15.591
E	4.450	17.675	10.930	15.920	0.000	0.000	0.000	16.116
ESE	5.310	23.227	0.000	0.000	83.580	0.000	40.700	33.212
SE	6.170	15.140	40.271	16.180	0.000	0.000	12.350	22.457
SSE	7.221	14.299	23.010	20.862	10.841	0.000	47.380	19.811
S	6.102	15.084	20.574	19.939	22.764	31.372	47.980	22.542
SSW	4.752	20.671	29.488	29.073	25.374	35.019	45.110	27.802
SW	6.175	14.621	34.100	26.408	33.897	0.000	0.000	25.012
WSW	13.440	17.419	28.020	24.460	0.000	0.000	0.000	21.961
W	6.105	14.582	0.000	0.000	0.000	0.000	0.000	14.804
WSW	5.268	14.797	23.470	0.000	0.000	0.000	0.000	13.252
W	6.484	27.483	26.704	32.277	0.000	0.000	0.000	15.969
WNW	7.073	15.595	24.614	34.506	27.534	45.160	0.000	23.592
W	7.217	17.325	26.384	25.619	24.427	32.945	41.465	

NUMBER OF OBSERVATIONS AVERAGED IN THE LAKE UNION 48.2 m LENGTH  
SCALE TABLES BY WIND SPEED AND DIRECTION

DIR., (DEGS.)	<1	1-3	3-5	5-7	7-9	9-11	>11	TOTAL
N	8,000	64,000	39,000	21,000	2,000	0,000	0,000	154,000
NNE	5,700	54,000	29,000	6,000	6,000	0,000	0,000	94,000
NE	7,000	47,000	44,000	4,000	0,000	0,000	0,000	105,000
ENE	5,700	22,000	13,000	3,000	0,000	0,000	0,000	43,000
E	2,000	11,000	1,000	1,000	0,000	0,000	0,000	14,000
ESE	1,000	4,000	0,000	0,000	1,000	0,000	1,000	6,000
SE	4,000	10,000	7,000	1,000	0,000	0,000	1,000	23,000
SSE	3,000	22,000	27,000	5,000	4,000	0,000	1,000	62,000
S	6,000	14,000	52,000	101,000	53,000	17,000	2,000	245,000
SSW	4,000	12,000	63,000	70,000	19,000	7,000	3,000	225,000
SW	4,000	67,000	39,000	16,000	4,000	0,000	0,000	127,000
WSW	5,000	28,000	17,000	2,000	0,000	0,000	0,000	62,000
W	10,000	14,000	0,000	0,000	0,000	0,000	0,000	28,000
WSW	6,000	6,000	1,000	0,000	0,000	0,000	0,000	13,000
W	5,000	20,000	28,000	11,000	0,000	0,000	0,000	70,000
WNW	4,000	54,000	75,000	34,000	9,000	1,000	0,000	183,000
	81,000	513,000	655,000	281,000	91,000	25,000	6,000	

AVERAGE LONGITUDINAL COMPONENT TURBULENCE LENGTH SCALES AT THE KIXI  
77.1 m LEVEL BY WIND SPEED AND DIRECTION

DIRN. (DEGS.)	<1	1-3	3-5	5-7	7-9	9-11	>11	TOTAL
N	9.186	24.134	33.089	60.900	46.500	54.600	0.000	34.450
NNE	0.000	22.830	35.415	57.143	0.000	0.000	0.000	30.265
NE	9.700	19.553	33.175	57.750	55.600	0.000	0.000	27.211
ENE	10.000	17.057	29.289	71.600	0.000	0.000	0.000	24.471
E	8.880	24.640	47.872	0.000	0.000	0.000	0.000	25.384
ESE	9.800	23.300	0.000	0.000	0.000	0.000	0.000	18.800
SE	0.000	24.111	36.600	85.100	0.000	0.000	0.000	33.695
SSE	0.000	19.444	39.277	39.833	46.300	0.000	0.000	34.600
S	14.300	23.150	42.603	49.545	46.800	56.200	0.000	41.117
SSW	11.700	22.014	36.305	57.582	28.500	0.000	0.000	32.904
SW	10.633	18.632	39.396	62.417	65.500	0.000	0.000	31.310
WSW	5.463	20.229	18.800	0.000	0.000	0.000	0.000	17.594
W	9.169	19.678	14.600	0.000	0.000	0.000	0.000	16.470
WNW	5.400	17.114	16.300	0.000	0.000	0.000	0.000	15.722
WS	7.400	24.367	36.875	99.033	0.000	0.000	0.000	47.736
WSW	0.000	22.285	45.917	50.381	59.200	50.800	0.000	44.367
W	0.874	21.516	38.098	55.424	50.300	54.480	0.000	

AVERAGE LATERAL COMPONENT TURBULENCE LENGTH SCALES AT THE KIXI  
77.1 M LEVEL BY WIND SPEED AND DIRECTION

DIRN. (DEGS.)	<1	1-3	3-5	5-7	7-9	9-11	>11	TOTAL
N	5.714	17.906	29.356	32.972	57.033	71.500	0.000	25.217
NNE	0.000	19.616	26.093	46.257	0.000	0.000	0.000	24.249
NE	11.025	21.520	26.213	32.200	55.700	0.000	0.000	23.853
ENE	9.750	15.229	28.550	24.100	0.000	0.000	0.000	20.571
E	6.633	12.150	35.000	0.000	0.000	0.000	0.000	16.576
ESE	7.400	28.250	0.000	0.000	0.000	0.000	0.000	21.300
SE	0.000	23.953	24.467	89.900	0.000	0.000	0.000	27.223
SSE	0.000	15.300	30.452	32.350	20.100	0.000	0.000	26.860
S	4.600	23.214	30.994	31.491	56.284	33.850	0.000	30.691
SSW	12.200	22.786	33.456	41.809	47.200	0.000	0.000	28.964
SW	8.617	19.612	33.200	35.817	71.050	0.000	0.000	27.155
WSW	6.313	16.023	35.650	0.000	0.000	0.000	0.000	16.057
W	4.312	11.972	14.500	0.000	0.000	0.000	0.000	9.750
WSW	6.000	20.300	16.800	0.000	0.000	0.000	0.000	18.544
W	5.300	16.100	50.625	70.667	0.000	0.000	0.000	42.555
WNW	0.900	17.546	29.500	37.467	46.838	23.700	0.000	31.694
WNW	6.475	16.212	29.925	37.676	42.844	46.380	0.000	

AVERAGE VERTICAL COMPONENT TURBULENCE LENGTH SCALES AT THE KIXI  
77.1 m LEVEL BY WIND SPEED AND DIRECTION

DIRN. (DEGS.)	<1	1-3	3-5	5-7	7-9	9-11	>11	TOTAL
N	4.759	12.292	22.379	23.446	21.673	25.375	0.000	17.495
NNE	0.000	15.273	24.855	25.637	0.000	0.000	0.000	19.520
NE	5.530	14.124	18.477	26.460	23.560	0.000	0.000	15.687
ENE	6.950	15.167	19.900	11.250	7.000	0.000	0.000	15.688
E	4.756	14.135	16.304	0.000	0.000	0.000	0.000	12.123
ESE	5.130	8.605	0.000	0.000	1.000	0.000	0.000	7.447
SE	0.000	16.251	25.143	25.420	1.000	0.000	0.000	21.535
SSE	0.000	13.533	23.564	20.373	12.745	0.000	0.000	20.224
S	5.040	16.291	22.393	27.798	3.433	15.605	0.000	20.699
SSW	12.330	16.428	24.050	24.455	23.060	0.000	0.000	20.978
SW	6.415	12.620	19.703	17.688	28.750	0.000	0.000	15.738
WSW	6.251	12.344	14.835	0.000	0.000	0.000	0.000	11.178
W	5.100	11.501	13.550	0.000	0.000	0.000	0.000	9.735
WNW	2.570	13.030	10.980	0.000	0.000	0.000	0.000	11.679
NW	10.700	8.833	34.918	34.583	0.000	0.000	0.000	25.511
NNW	0.000	15.028	29.957	27.736	37.365	23.730	0.000	27.304
	5.290	13.795	23.162	24.728	23.161	21.138	0.000	

NUMBER OF OBSERVATIONS AVERAGED IN THE KIXI 77.1 m LENGTH SCALE  
TABLES BY WIND SPEED AND DIRECTION

CIR. (OCCS.)	<1	1-3	3-5	5-7	7-9	9-11	>11	TOTAL
N	7,000	53,000	47,000	18,000	3,000	2,000	0,000	130,000
NNE	0,000	44,000	27,000	7,000	0,000	0,000	0,000	78,000
NE	4,000	15,000	16,000	2,000	1,000	0,000	0,000	38,000
ENE	2,000	7,000	7,000	1,500	0,000	0,000	0,000	17,000
E	5,000	10,000	4,000	0,000	0,000	0,000	0,000	19,000
ESE	1,000	2,000	0,000	0,000	0,000	0,000	0,000	3,000
SE	0,000	9,000	12,000	1,000	0,000	0,000	0,000	22,000
SESE	0,000	16,000	40,000	12,000	2,000	0,000	0,000	72,000
S	1,000	14,000	31,000	11,000	19,000	2,000	0,000	78,000
SSW	1,000	36,000	43,000	11,000	1,000	0,000	0,000	92,000
SW	6,000	25,000	23,000	6,000	2,000	0,000	0,000	62,000
WSW	8,000	35,000	4,000	0,000	0,000	0,000	0,000	47,000
W	16,000	37,000	1,000	0,000	0,000	0,000	0,000	54,000
WNW	1,500	7,000	1,000	6,000	0,000	0,000	0,000	9,000
NW	1,000	3,000	4,000	3,000	0,000	0,000	0,000	11,000
NNW	0,000	13,000	23,000	21,000	8,000	1,000	0,000	66,000
	53,000	328,000	263,000	93,000	36,000	5,000	0,000	

AVERAGE LONGITUDINAL COMPONENT TURBULENCE LENGTH SCALES AT THE KIXI  
95.4 m LEVEL BY WIND SPEED AND DIRECTION

DIRN. (DEGS.)	<1	1-3	3-5	5-7	7-9	9-11	>11	TOTAL
N	7.667	22.996	35.774	49.586	0.000	52.100	0.000	31.624
NNE	10.520	22.445	28.976	48.567	0.000	0.000	0.000	24.581
NE	8.267	16.222	26.762	16.100	0.000	0.000	0.000	19.451
ENE	6.975	21.600	34.988	38.000	0.000	0.000	0.000	25.933
E	9.050	15.133	51.033	0.000	0.000	0.000	0.000	23.818
ESE	0.000	17.233	70.800	0.000	0.000	0.000	0.000	30.625
SE	0.000	21.618	31.927	46.600	0.000	0.000	0.000	27.635
SSE	9.700	25.987	32.812	39.040	0.000	0.000	0.000	31.151
S	6.229	22.970	37.629	49.479	55.125	0.000	0.000	32.703
SSW	12.550	17.928	37.930	44.675	42.600	0.000	0.000	30.865
SW	10.356	16.232	37.600	31.100	0.000	0.000	0.000	19.393
WSW	7.560	16.439	26.567	0.000	0.000	0.000	0.000	16.116
W	6.840	17.062	0.000	0.000	0.000	0.000	0.000	15.096
WNW	6.960	15.440	14.500	0.000	0.000	0.000	0.000	12.713
NW	11.650	15.450	41.800	64.200	41.300	0.000	0.000	37.013
NNW	10.920	22.063	43.643	47.327	47.878	0.000	0.000	39.794
	8.715	19.914	35.893	46.855	59.869	52.100	0.000	

AVERAGE LATERAL COMPONENT TURBULENCE LENGTH SCALES AT THE KIXI  
95.4 m LEVEL BY WIND SPEED AND DIRECTION

DIR. (DEGS.)	<1	1-3	3-5	5-7	7-9	9-11	>11	TOTAL
N	6.700	21.159	30.300	44.448	0.000	47.250	0.000	27.960
NNE	6.780	18.869	22.557	40.367	0.000	0.000	0.000	19.997
NE	10.567	16.172	20.508	29.200	0.000	0.000	0.000	17.674
ENE	4.175	6.050	24.339	46.500	0.000	0.000	0.000	19.333
E	4.150	8.883	35.667	0.000	0.000	0.000	0.000	15.691
ESE	0.000	17.933	22.100	0.000	0.000	0.000	0.000	18.975
SE	0.000	10.730	26.827	105.800	0.000	0.000	0.000	25.417
SSE	7.150	19.260	26.441	28.460	0.000	0.000	0.000	24.374
S	5.785	21.651	26.781	32.343	14.075	0.000	0.000	25.024
SSW	6.450	19.675	28.130	15.683	33.300	0.000	0.000	25.429
SW	6.711	20.314	30.159	24.200	0.000	0.000	0.000	19.625
WSW	6.489	13.454	32.200	10.000	0.000	0.000	0.000	14.270
W	7.570	13.952	6.000	0.000	0.000	0.000	0.000	12.715
WNW	6.740	14.980	14.000	0.000	0.000	0.000	0.000	11.781
NW	6.950	14.200	46.320	46.075	22.600	0.000	0.000	32.325
WNW	9.720	21.247	32.013	37.523	70.422	0.000	0.000	3.453
W	7.917	18.173	28.967	37.879	55.206	47.250	0.000	

AVERAGE VERTICAL COMPONENT TURBULENCE LENGTH SCALES AT THE KIXI  
95.4 M LEVEL BY WIND SPEED AND DIRECTION

DIRN. (DEGS.)	<1	1-3	3-5	5-7	7-9	9-11	>11	TOTAL
N	5.003	15.237	23.477	24.823	0.000	31.770	0.000	19.452
NNE	7.122	14.669	20.233	28.650	0.000	0.000	0.000	16.446
NE	10.033	16.174	15.419	13.650	0.000	0.000	0.000	15.295
ENE	4.310	13.120	16.121	18.740	0.000	0.000	0.000	12.746
E	6.735	14.893	30.670	0.000	0.000	0.000	0.000	18.076
ESE	0.000	16.253	21.150	0.000	0.000	0.000	0.000	21.478
SE	0.000	19.756	22.268	29.140	0.000	0.000	0.000	21.366
SSE	14.840	21.010	27.134	24.454	0.000	0.000	0.000	25.114
S	6.634	19.104	27.020	29.055	22.750	0.000	0.000	23.076
SSW	6.625	20.281	25.631	28.943	12.075	0.000	0.000	24.311
SW	9.751	15.558	28.994	19.835	0.000	0.000	0.000	15.584
WSW	7.441	16.246	24.487	0.000	0.000	0.000	0.000	15.760
W	5.278	14.476	0.000	0.000	0.000	0.000	0.000	12.694
WNW	3.586	12.153	17.520	6.000	0.000	0.000	0.000	10.280
NW	12.450	11.623	32.474	37.253	20.240	0.000	0.000	25.188
NNW	0.100	19.306	27.666	32.508	18.531	0.000	0.000	25.255
	7.561	16.767	24.729	28.139	17.011	31.770	0.000	

NUMBER OF OBSERVATIONS AVERAGED IN THE KIXI 95.4 m LENGTH SCALE  
TABLES BY WIND SPEED AND DIRECTION

DIRN. (DEGS.)	<1	1-3	3-5	5-7	7-9	9-11	>11	TOTAL
N	6,000	54,000	47,000	21,000	9,000	2,000	0,000	130,000
NNE	5,000	44,000	21,000	3,000	2,000	0,000	0,000	73,000
NE	3,000	16,000	13,000	1,000	0,000	0,000	0,000	35,000
ENE	4,000	2,000	8,000	1,000	2,000	0,000	0,000	15,000
E	2,000	6,000	3,000	0,000	0,000	0,000	0,000	11,000
ESE	0,000	3,000	1,000	0,000	0,000	0,000	0,000	4,000
SE	0,000	11,000	11,000	1,000	0,000	0,000	0,000	23,000
SSE	2,000	15,000	34,000	10,000	7,000	0,000	0,000	61,000
S	7,000	37,000	42,000	14,000	0,000	0,000	0,000	104,000
SSW	2,000	32,000	37,000	12,000	2,000	0,000	0,000	85,000
SW	9,000	22,000	7,000	2,000	0,000	0,000	0,000	40,000
WSW	9,000	45,000	6,000	0,000	0,000	0,000	0,000	61,000
W	5,000	21,000	0,000	0,000	0,000	0,000	0,000	26,000
WNW	5,000	10,000	1,000	0,000	0,000	0,000	0,000	16,000
NW	2,000	4,000	5,000	4,000	1,000	0,000	0,000	16,000
NNW	5,000	19,000	30,000	15,000	9,000	0,000	0,000	78,000
	66,000	344,000	266,000	84,000	14,000	2,000	0,000	

AVERAGE LONGITUDINAL COMPONENT TURBULENCE LENGTH SCALES AT THE SEA-TAC  
7.1 m LEVEL BY WIND SPEED AND DIRECTION

DIR., (DEGS.)	<1	1-3	3-5	5-7	7-9	9-11	>11	TOTAL
N	8.511	14.602	33.425	0.000	0.000	0.000	0.000	18.916
NNE	6.175	20.621	26.911	44.171	31.400	0.000	0.000	24.262
NE	3.400	16.358	30.682	48.600	0.000	0.000	0.000	24.853
ENE	4.300	16.257	23.133	0.000	0.000	0.000	0.000	17.045
E	7.500	17.620	36.400	0.000	0.000	0.000	0.000	19.731
ESE	9.250	16.604	26.800	60.200	0.000	0.000	0.000	18.303
SE	7.300	14.971	39.533	0.000	0.000	0.000	0.000	15.088
SSE	11.757	16.785	26.629	62.133	0.000	0.000	0.000	22.104
S	10.914	16.663	34.261	52.350	0.000	41.800	0.000	24.686
SSW	6.733	22.678	33.805	42.617	60.220	0.000	0.000	31.841
SW	7.167	21.409	33.742	47.737	41.083	0.000	0.000	30.959
WSW	7.500	19.232	27.333	0.000	25.100	0.000	0.000	20.402
W	6.100	18.281	26.557	0.000	0.000	0.000	0.000	18.790
WNW	4.450	17.896	29.750	0.000	0.000	0.000	0.000	20.267
NW	6.467	20.706	30.220	70.300	60.733	0.000	0.000	25.333
NNW	5.611	15.283	22.786	31.600	0.000	0.000	0.000	15.243
	7.946	16.373	31.325	47.236	49.144	41.800	0.000	

AVERAGE LATERAL COMPONENT TURBULENCE LENGTH SCALES AT THE SEA-TAC  
7.1 m LEVEL BY WIND SPEED AND DIRECTION

DIRN. (DEGS.)	<1	1-3	3-5	5-7	7-9	9-11	>11	TOTAL
N	5.278	11.095	24.709	0.000	0.000	0.000	0.000	14.076
NNE	5.425	13.110	24.232	26.186	13.519	0.000	0.000	18.539
NE	5.600	15.589	23.945	24.740	0.000	0.000	0.000	19.136
ENE	4.000	15.829	27.467	0.000	0.000	0.000	0.000	17.927
E	3.900	15.750	14.600	0.000	0.000	0.000	0.000	14.631
ESE	15.900	16.267	19.450	31.100	0.000	0.000	0.000	16.972
SE	6.089	13.061	27.600	0.000	0.000	0.000	0.000	12.763
SSE	10.929	16.648	22.141	29.983	0.000	0.000	0.000	18.403
S	8.700	15.873	25.912	32.938	0.000	62.900	0.000	19.397
SSW	5.500	18.064	27.995	34.445	42.540	0.000	0.000	25.647
SW	8.100	18.635	26.313	33.974	55.250	0.000	0.000	25.328
WSW	12.225	19.813	26.725	0.000	64.200	0.000	0.000	21.833
W	5.800	18.150	30.929	0.000	0.000	0.000	0.000	19.855
WNW	6.050	19.050	26.480	0.000	0.000	0.000	0.000	20.321
NNW	5.967	17.084	22.860	21.000	36.100	0.000	0.000	18.863
NW	3.044	12.403	26.444	44.900	0.000	0.000	0.000	14.332
	7.189	16.069	25.781	32.657	45.788	62.900	0.000	

AVERAGE VERTICAL COMPONENT TURBULENCE LENGTH SCALES AT THE SEA-TAC  
7.1 M LEVEL BY WIND SPEED AND DIRECTION

DIR. (DEGS.)	<1	1-3	3-5	5-7	7-9	9-11	>11	TOTAL
N	2.762	7.014	11.055	0.000	0.000	0.000	0.000	7.652
NNE	2.611	7.196	11.192	14.081	9.600	0.000	0.000	9.169
NE	.240	6.631	10.617	11.890	0.000	0.000	0.000	8.453
ENE	5.200	5.911	7.923	0.000	0.000	0.000	0.000	6.403
E	3.900	7.885	8.670	0.000	0.000	0.000	0.000	7.699
ESE	5.325	6.604	6.965	10.940	0.000	0.000	0.000	6.696
SE	1.982	5.844	11.074	0.000	0.000	0.000	0.000	5.636
SSE	2.006	6.915	9.976	11.253	0.000	0.000	0.000	7.685
S	4.166	6.820	10.181	10.358	0.000	12.020	0.000	7.744
SSW	2.797	8.924	11.941	12.320	14.008	0.000	0.000	10.795
SW	2.724	8.368	13.095	15.346	14.267	0.000	0.000	11.435
WSW	1.563	9.748	11.306	0.000	16.920	0.000	0.000	9.605
W	2.513	9.661	12.064	0.000	0.000	0.000	0.000	9.551
WNW	2.875	6.266	14.009	0.000	0.000	0.000	0.000	9.462
NW	4.593	8.812	12.356	44.510	29.683	0.000	0.000	11.383
NNW	2.797	6.948	11.364	22.000	0.000	0.000	0.000	7.476
	3.029	7.723	11.552	13.715	16.998	12.020	0.000	

NUMBER OF OBSERVATIONS AVERAGED IN THE SEA-TAC 7.1 m LENGTH  
SCALE TABLES BY WIND SPEED AND DIRECTION

DIRN. (DEGS.)	<1	1-3	3-5	5-7	7-9	9-11	>11	TOTAL
N	9,000	59,000	24,000	0,000	0,000	0,000	0,000	92,000
NNE	6,000	29,000	37,000	7,000	1,000	0,000	0,000	82,000
NE	1,000	19,000	11,000	5,000	0,000	0,000	0,000	36,000
ENE	1,000	7,000	3,000	0,000	0,000	0,000	0,000	11,000
E	1,000	10,000	2,000	0,000	0,000	0,000	0,000	13,000
ESE	2,000	24,000	2,000	1,000	0,000	0,000	0,000	29,000
SE	9,000	28,000	3,000	0,000	0,000	0,000	0,000	40,000
SSE	7,000	46,000	17,000	6,000	0,000	0,000	0,000	76,000
S	14,000	60,000	33,000	8,000	0,000	1,000	0,000	116,000
SSW	3,000	55,000	58,000	29,000	5,000	0,000	0,000	150,000
SW	6,000	54,000	52,000	27,000	6,000	0,000	0,000	145,000
WSW	4,000	31,000	12,000	0,000	1,000	0,000	0,000	48,000
W	3,000	32,000	7,000	0,000	0,000	0,000	0,000	42,000
WNW	2,000	27,000	10,000	0,000	0,000	0,000	0,000	39,000
NW	3,000	31,000	10,000	1,000	3,000	0,000	0,000	48,000
NNW	9,000	29,000	7,000	2,000	0,000	0,000	0,000	47,000
	82,000	541,000	288,600	60,000	16,000	1,000	0,000	9,000

AVERAGE LONGITUDINAL COMPONENT TURBULENCE LENGTH SCALES AT THE SEA-TAC  
27.0 M LEVEL BY WIND SPEED AND DIRECTION

DIRN. (DEGR.)	1-2	3-5	5-7	7-9	9-11	>11	TOTAL
N	2.250	17.172	32.391	34.867	0.100	0.000	24.678
NNE	7.200	16.793	76.435	49.100	0.000	0.000	29.560
NE	1.000	15.121	31.461	52.400	0.000	0.000	29.954
ENE	0.000	22.725	21.780	27.300	0.000	0.000	23.429
E	0.000	16.678	32.509	42.933	0.000	0.000	20.394
ESE	1.300	21.155	16.400	65.300	0.000	0.000	21.556
SE	6.100	11.562	24.600	67.000	0.000	0.000	15.855
SSE	7.025	19.763	63.474	72.300	27.130	0.000	25.692
S	7.000	17.125	32.942	50.693	91.150	0.000	28.005
SSW	0.000	21.007	36.152	47.637	72.167	0.000	36.189
SW	10.267	20.279	37.041	52.145	50.725	0.000	35.750
WSW	13.200	17.371	33.563	39.000	59.700	0.000	23.272
W	7.233	18.284	27.880	0.000	0.000	0.000	19.257
WNW	5.600	19.248	36.513	0.000	0.000	0.000	24.707
NW	0.000	23.600	35.161	49.600	62.900	0.000	32.040
NNW	5.600	19.119	30.264	45.300	51.200	0.000	23.940
	6.921	18.514	34.150	49.026	61.104	73.917	2.000

AVERAGE LATERAL COMPONENT TURBULENCE LENGTH SCALES AT THE SEA-TAC  
27.0 M LEVEL BY WIND SPEED AND DIRECTION

DIR.	DEGS.	1-3	3-5	5-7	7-9	9-11	>11	TOTAL
N	0.167	13.854	25.830	43.000	0.000	0.000	0.000	20.050
NNE	11.833	14.888	24.724	22.867	41.200	0.000	0.000	29.624
NE	0.000	16.928	24.417	36.013	27.500	0.000	0.000	23.410
ENE	0.000	18.013	24.040	23.622	0.000	0.000	0.000	21.021
E	13.125	22.731	27.700	30.800	0.000	0.000	0.000	22.176
ESE	16.860	16.965	10.967	23.000	0.000	9.000	0.000	17.680
SE	6.725	13.872	17.900	28.550	0.000	0.000	0.000	14.805
SSE	5.825	17.075	22.283	38.767	20.000	0.000	0.000	19.033
S	0.925	14.442	23.687	32.273	20.000	70.500	0.000	20.103
SSW	0.000	15.943	25.112	28.482	31.733	23.450	0.000	23.277
SW	6.947	10.043	26.524	41.255	44.225	47.500	0.000	27.536
WSW	5.800	17.343	26.713	30.500	28.770	0.000	0.000	20.954
W	13.267	20.072	41.844	0.000	0.000	0.000	0.000	23.843
WNW	4.100	17.490	25.734	0.000	0.000	0.000	0.000	19.944
W	0.000	14.718	25.407	19.050	37.050	29.400	0.000	20.476
WNW	7.700	18.637	22.962	22.600	24.100	0.000	0.000	18.144
W	4.721	14.368	25.411	32.239	34.227	43.633	0.000	

AVERAGE VERTICAL COMPONENT TURBULENCE LENGTH SCALES AT THE SEA-TAC  
27.0 m LEVEL BY WIND SPEED AND DIRECTION

DIRN. (DEGS.)	<1	1-3	3-5	5-7	7-9	9-11	>11	TOTAL
N	7.955	10.538	14.291	13.303	0.000	0.000	0.000	12.291
NNE	5.515	11.668	15.874	19.443	27.430	0.000	0.000	15.078
NE	0.000	7.507	19.093	21.993	18.700	0.000	0.000	14.531
ENE	0.000	13.593	12.818	22.950	0.000	0.000	0.000	13.988
E	4.170	10.379	19.910	21.160	0.000	0.000	0.000	11.381
ESE	0.000	9.239	11.223	20.870	0.000	0.000	0.000	10.004
SE	1.880	7.248	12.457	16.580	0.000	0.000	0.000	8.524
SSE	4.997	10.997	13.504	25.040	21.030	0.000	0.000	12.351
S	2.237	10.068	15.567	14.914	18.115	17.280	0.000	12.483
SSW	0.000	12.898	18.683	19.119	22.406	25.510	0.000	17.157
SW	3.753	13.111	19.580	21.054	23.128	29.910	0.000	17.757
WSW	8.710	15.023	19.386	27.420	35.660	0.000	0.000	16.814
W	5.993	15.022	18.903	0.000	0.000	0.000	0.000	15.025
WNW	5.210	13.958	20.247	0.000	0.000	0.000	0.000	15.860
W	0.000	13.721	23.899	47.455	42.070	57.810	0.000	21.531
NNW	7.117	9.139	16.030	18.944	21.450	0.000	0.000	11.928
N	4.773	11.645	17.398	19.857	24.612	30.986	0.000	

NUMBER OF OBSERVATIONS AVERAGED IN THE SEA-TAC 27.0 m LENGTH  
SCALE, TABLES BY WIND SPEED AND DIRECTION

DIR., (DEGS.)	<1	1-3	3-5	5-7	7-9	9-11	>11	TOTAL
N	2,000	39,000	37,000	3,000	0,000	0,000	0,000	81,000
NNE	3,000	29,000	34,000	18,000	1,000	0,000	0,000	85,000
NE	0,000	18,000	12,000	6,000	1,000	0,000	0,000	39,000
ENE	0,000	8,000	5,000	1,000	0,000	0,000	0,000	14,000
E	4,000	9,000	1,000	3,000	0,000	0,000	0,000	17,000
ESE	1,000	20,000	3,000	1,000	0,000	0,000	0,000	25,000
SE	4,000	29,000	7,000	2,000	0,000	0,000	0,000	42,000
SSE	4,000	36,000	19,000	3,000	1,000	0,000	0,000	63,000
S	8,000	48,000	40,000	15,000	2,000	1,000	0,000	114,000
SSW	0,000	54,000	57,000	38,000	9,000	2,000	0,000	160,000
SW	3,000	47,000	49,000	31,000	6,000	2,000	0,000	140,000
WSW	1,000	35,000	16,000	1,000	1,000	0,000	0,000	54,000
W	3,000	25,000	7,000	0,000	0,000	0,000	0,000	35,000
WNW	1,000	29,000	15,000	0,000	0,000	0,000	0,000	45,000
NW	0,000	22,000	18,000	2,000	2,000	1,000	0,000	45,000
NNW	4,000	27,000	11,000	5,000	1,000	0,000	0,000	48,000
	38,000	475,000	331,000	131,000	26,000	6,000	0,000	

## APPENDIX G

### TURBULENCE TIME SCALE DISTRIBUTIONS

The data in Appendix F show little, if any, systematic variation of turbulence length scales with wind direction. As a result, the distributions of turbulence time scales presented in this Appendix have not been prepared as a function of wind direction as was done in Appendix E. Rather, all wind directions have been combined.

The tables in this Appendix are presented with an upper and lower portion as was done in Appendix E. Again, the number of observations included in each table is given between the sections.

In these tables the percent frequency of occurrence of each time scale (length scale/wind speed) and wind speed category combination is tabulated in the upper section. The summation of all entries in this section, exclusive of marginal totals, is 100 percent. The distribution of time scales without regard to the wind speed is given in the lowest row, while the total column gives the wind speed distribution.

In the lower portion of the tables of this Appendix, the data from the upper portion are repeated. However, each entry has been normalized to the percent frequency of occurrence of the wind speed category. Thus, the sum of the frequencies of occurrence in each row should equal 100 percent.

The data from Appendix G were used extensively in Chapter 10. Prior to use of these data to determine distributions of actual length scales, the appropriate values of  $A_y$  from Table 10 should be applied to the time scale category limits to obtain more realistic values.

FREQUENCY DISTRIBUTIONS OF THE LONGITUDINAL COMPONENT TIME SCALE AT THE  
LAKE UNION 6.9 m LEVEL BY WIND SPEED

SPEED (M/SEC)	0.0-2.0	2.0-4.0	4.0-6.0	6.0-8.0	8.0-10.0	10.0-12.0	12.0-14.0	14.0-16.0	16.0-18.0	>18.0	TOTAL
<1	0.00	.19	.94	1.93	2.07	1.56	1.41	1.23	1.27	1.74	12.35
1-3	.14	2.55	8.61	11.69	9.83	7.31	6.41	3.58	3.16	4.48	57.80
3-5	.19	1.27	4.20	5.99	4.34	2.59	2.07	1.37	.99	1.41	24.42
5-7	0.00	.33	1.13	1.27	.42	.52	.42	.19	.09	.09	4.48
7-9	0.00	.14	.19	.65	.19	.19	0.00	0.00	0.00	0.00	.75
9-11	0.00	0.00	.65	.14	0.00	0.00	0.00	0.00	0.00	0.00	.19
>11	0.00	0.00	0.00	0.00	0.00	0.00	0.00	0.00	0.00	0.00	0.00
	.43	4.48	15.13	21.07	14.81	12.16	10.33	6.36	5.52	7.73	

TOTAL NO. OF OBSERVATIONS USED IN THIS TABLE = 2121.

SPEED (M/SEC)	0.0-2.0	2.0-4.0	4.0-6.0	6.0-8.0	8.0-10.0	10.0-12.0	12.0-14.0	14.0-16.0	16.0-18.0	>18.0	TOTAL
<1	0.00	1.53	7.63	15.65	16.77	12.60	11.45	9.92	10.31	14.12	100.00
1-3	1.24	4.40	14.93	20.23	17.03	12.64	11.09	6.20	5.46	7.75	100.00
3-5	.77	3.21	17.18	24.52	17.73	10.62	8.49	5.60	4.05	5.79	100.00
5-7	0.00	1.37	25.26	28.42	9.47	11.58	9.47	4.21	2.11	2.11	100.00
7-9	0.00	14.75	25.60	6.25	25.00	25.00	0.00	0.00	0.00	0.00	100.00
9-11	0.00	0.00	25.60	75.00	0.00	0.00	0.00	0.00	0.00	0.00	100.00
>11	0.00	0.00	0.00	0.00	0.00	0.00	0.00	0.00	0.00	0.00	0.00

FREQUENCY DISTRIBUTIONS OF THE LATERAL COMPONENT TIME SCALE AT THE LAKE  
UNION 6.9 M LEVEL BY WIND SPEED

SPEED (M/SEC)	0.0-2.0	2.0-4.0	4.0-6.0	6.0-8.0	8.0-10.	10.-12.	12.-14.	14.-16.	16.-18.	>18.	TOTAL
<1	6.05	.28	1.32	1.74	2.12	1.56	1.84	1.04	1.04	1.41	12.35
1-3	.28	4.20	11.05	10.75	9.31	6.65	5.19	3.21	2.64	4.48	57.80
3-5	.24	3.19	6.46	5.70	2.67	2.03	1.70	.66	.42	1.13	24.42
5-7	.65	1.04	1.04	.99	.75	.38	.09	.05	.05	.05	4.48
7-9	0.10	.17	.38	0.00	.03	.05	0.00	0.00	.09	0.00	.75
9-11	0.20	0.00	.05	.05	0.01	.09	0.00	0.00	0.00	0.00	.19
>11	0.30	0.00	0.00	0.00	0.01	0.00	0.00	0.00	0.00	0.00	0.00
	.67	4.10	20.32	19.24	14.95	10.75	6.82	4.95	4.24	7.07	

TOTAL NO. OF OBSERVATIONS USED IN THIS TABLE = 2121.

SP (M/SEC)	0.0-2.0	2.0-4.0	4.0-6.0	6.0-8.0	8.0-10.	10.-12.	12.-14.	14.-16.	16.-18.	>18.	TOTAL
<1	0.10	2.29	10.49	14.12	17.18	12.60	14.89	8.40	8.40	11.45	100.00
1-3	.40	1.24	19.17	18.60	16.15	11.50	6.97	5.55	4.57	7.75	100.00
3-5	.47	13.90	28.45	23.36	11.00	8.30	6.95	2.70	1.74	4.63	100.00
5-7	1.05	23.14	23.14	22.11	16.64	8.42	2.11	1.05	1.05	1.05	100.00
7-9	0.00	25.00	50.00	0.00	6.25	6.25	0.00	0.00	12.50	0.00	100.00
9-11	0.00	0.00	25.00	25.00	0.00	50.00	0.00	0.00	0.00	0.00	100.00
>11	0.00	0.00	0.00	0.00	0.01	0.00	0.00	0.00	0.00	0.00	0.00

FREQUENCY DISTRIBUTIONS OF THE VERTICAL COMPONENT TIME SCALE AT THE LAKE  
UNION 6.9 m LEVEL BY WIND SPEED

SPEED (M/SEC)	0.0-1.0	1.0-2.0	2.0-3.0	3.0-4.0	4.0-5.0	5.0-6.0	6.0-7.0	7.0-8.0	8.0-9.0	>9.0	TOTAL
<1	.42	.14	.99	1.98	1.84	1.93	1.08	.90	1.08	1.93	12.31
1-3	.00	2.74	13.49	13.82	10.02	6.89	4.01	2.36	1.70	2.31	57.63
3-5	.24	3.52	9.76	3.92	1.70	1.70	.85	.19	.19	.33	24.43
5-7	.05	1.75	1.75	.38	.28	.09	0.00	.05	.00	.14	4.48
7-9	0.00	.42	.28	.05	0.00	0.00	0.00	0.00	0.00	0.00	.75
9-11	.05	.14	0.00	0.00	0.00	0.00	0.00	0.00	0.00	0.00	.19
>11	0.00	0.00	0.00	0.00	0.00	0.00	0.00	0.00	0.00	0.00	0.00
	.90	10.71	24.27	20.14	14.05	10.61	5.90	3.49	3.97	4.72	

TOTAL NO. OF OBSERVATIONS USED IN THIS TABLE \* 2120.

SPEED (M/SEC)	0.0-1.0	1.0-2.0	2.0-3.0	3.0-4.0	4.0-5.0	5.0-6.0	6.0-7.0	7.0-8.0	8.0-9.0	>9.0	TOTAL
<1	3.45	1.15	8.05	15.09	14.94	15.71	8.81	7.28	8.81	15.7	100.00
1-3	.16	4.73	23.33	23.90	18.03	11.91	6.03	4.08	2.94	4.00	100.00
3-5	1.14	22.59	39.06	16.02	6.95	6.95	3.47	.77	.77	1.35	100.00
5-7	1.35	38.05	38.95	8.42	6.12	2.11	6.00	1.05	0.00	3.16	100.00
7-9	0.00	56.25	37.50	6.25	0.12	0.00	0.00	0.00	0.00	0.00	100.00
9-11	25.90	75.00	0.00	0.00	0.30	0.00	0.00	0.00	0.00	0.00	100.00
>11	0.00	0.00	0.00	0.00	0.12	0.00	0.00	0.00	0.00	0.00	0.00





FREQUENCY DISTRIBUTIONS OF THE VERTICAL COMPONENT TIME SCALE AT THE LAKE  
UNION 12.6 + 17.1 M LEVELS BY WIND SPEED

SPEED (M/SEC)	0.0-1.0	1.0-2.0	2.0-3.0	3.0-4.0	4.0-5.0	5.0-6.0	6.0-7.0	7.0-8.0	8.0-9.0	>9.0	TOTAL
<1	.10	.10	.39	1.06	1.11	1.40	1.45	1.45	1.16	2.65	10.95
1-7	.05	.48	6.17	10.03	10.42	6.15	5.89	3.52	2.75	7.33	54.80
3-5	0.00	2.12	8.43	6.22	3.76	1.83	1.21	.58	.63	.43	25.62
5-7	0.00	1.94	2.70	1.25	.82	.24	.10	.14	.14	0.00	7.38
7-9	0.00	.63	.58	.14	0.00	0.00	0.00	0.00	0.00	0.00	1.16
9-11	0.00	.05	0.00	0.00	0.00	0.00	0.00	0.00	0.00	0.00	.05
>11	0.00	0.00	.05	0.00	0.00	0.00	0.00	0.00	0.00	0.00	.05
TOTAL	.24	3.16	18.72	18.72	16.13	11.63	8.63	5.69	4.68	10.42	100.00

TOTAL NO. OF OBSERVATIONS USED IN THIS TABLE = 2073.

SPEED (M/SEC)	0.0-1.0	1.0-2.0	2.0-3.0	3.0-4.0	4.0-5.0	5.0-6.0	6.0-7.0	7.0-8.0	8.0-9.0	>9.0	TOTAL
<1	1.76	.88	3.52	9.69	10.13	12.78	13.22	13.22	10.57	24.23	100.00
1-3	.00	.64	11.27	18.31	19.01	14.88	10.74	6.43	5.02	13.38	100.00
3-5	0.00	4.29	34.46	24.29	14.65	7.16	4.71	2.26	2.45	1.69	100.00
5-7	0.00	26.80	34.40	16.99	11.11	3.27	1.31	1.96	1.96	0.00	100.00
7-9	0.00	37.50	50.00	12.50	0.00	0.00	0.00	0.00	0.00	0.00	100.00
9-11	0.00	100.00	0.00	0.00	0.00	0.00	0.00	0.00	0.00	0.00	100.00
>11	0.00	0.00	100.00	0.00	0.00	0.00	0.00	0.00	0.00	0.00	100.00

FREQUENCY DISTRIBUTIONS OF THE LONGITUDINAL COMPONENT TIME SCALE AT THE  
LAKE UNION 24.8 m LEVELS BY WIND SPEED

SPEED (M/SEC)	0.0-2.0	2.0-4.0	4.0-6.0	6.0-8.0	8.0-10.0	10.0-12.0	12.0-14.0	14.0-16.0	16.0-18.0	>18.0	TOTAL
<1	0.00	.09	.65	1.54	1.23	1.14	.77	.68	.47	1.41	7.72
1-3	.09	1.14	6.14	9.45	8.17	6.63	5.86	3.41	1.77	4.63	47.32
3-5	0.00	1.18	4.64	6.86	6.27	3.13	3.50	2.23	1.36	2.36	31.56
5-7	.44	.41	1.45	2.00	1.73	1.45	1.09	.54	.36	.41	10.49
7-9	0.00	.05	.68	.59	.27	.36	.09	.32	1.00	.09	2.45
9-11	0.10	0.00	.14	.27	0.00	0.00	0.00	0.00	0.00	0.00	.41
>11	0.00	0.00	0.00	0.00	0.00	0.00	.05	0.00	0.00	0.00	.05
	.73	2.40	13.99	20.73	17.64	12.72	11.35	7.18	3.91	8.90	

10

TOTAL NO. OF OBSERVATIONS USED IN THIS TABLE = 2202.

SPEED (M/SEC)	0.0-2.0	2.0-4.0	4.0-6.0	6.0-8.0	8.0-10.0	10.0-12.0	12.0-14.0	14.0-16.0	16.0-18.0	>18.0	TOTAL
<1	0.00	1.14	5.43	20.00	15.81	14.71	10.00	6.82	5.29	18.24	100.00
1-3	.10	2.40	13.95	19.96	17.27	14.01	12.38	7.20	3.74	9.79	100.00
3-5	0.00	3.74	14.62	21.73	19.86	9.93	11.08	7.05	4.32	7.48	100.00
5-7	6.14	3.90	17.75	19.05	16.45	13.85	10.39	5.19	3.46	3.90	100.00
7-9	0.00	1.65	27.78	24.07	11.11	14.81	3.70	12.96	0.00	3.70	100.00
9-11	0.00	0.00	31.33	66.67	0.00	0.00	0.00	0.00	0.00	0.00	100.00
>11	0.00	0.00	0.00	0.00	0.00	0.00	100.00	0.00	0.00	0.00	100.00



FREQUENCY DISTRIBUTIONS OF THE VERTICAL COMPONENT TIME SCALE AT THE LAKE  
UNION 24.8 m LEVELS BY WIND SPEED

SPEED (M/SEC)	0.0-1.0	1.0-2.0	2.0-3.0	3.0-4.0	4.0-5.0	5.0-6.0	6.0-7.0	7.0-8.0	8.0-9.0	>9.0	TOTAL
<1	.14	.05	.05	.27	.77	1.18	1.04	.59	.77	2.82	7.72
1-3	.05	.27	2.43	6.54	4.07	6.90	5.86	4.18	3.41	8.76	47.32
3-5	0.00	.77	6.00	4.27	0.04	3.68	1.91	1.36	.95	1.73	31.56
5-7	.04	1.14	3.65	2.59	1.32	.54	.41	.23	.14	.05	10.49
7-9	0.00	.59	1.14	.36	.14	.09	.05	.05	.05	0.00	2.45
9-11	0.00	.14	.14	0.00	0.00	0.00	.09	0.00	0.00	0.00	.41
>11	0.00	.05	0.00	0.00	0.00	0.00	0.00	0.00	0.00	0.00	.05
	.46	2.95	14.35	13.07	18.91	12.40	9.36	6.40	5.31	13.35	

TOTAL NO. OF OBSERVATIONS USED IN THIS TABLE = 2202.

SPEED (M/SEC)	0.0-1.0	1.0-2.0	2.0-3.0	3.0-4.0	4.0-5.0	5.0-6.0	6.0-7.0	7.0-8.0	8.0-9.0	>9.0	TOTAL
<1	2.04	.56	.54	3.53	10.07	15.29	13.53	7.65	10.00	36.47	100.00
1-3	.10	.58	4.47	13.92	18.33	14.59	12.38	8.83	7.20	18.52	100.00
3-5	0.00	2.30	21.87	24.19	19.11	11.65	6.04	4.32	3.02	5.47	100.00
5-7	0.00	10.47	17.00	24.68	12.55	5.19	3.90	2.16	1.30	.43	100.00
7-9	0.00	24.07	44.30	14.61	5.56	3.70	1.85	1.85	1.85	0.00	100.00
9-11	0.00	33.33	44.44	0.00	0.01	0.00	22.22	0.00	0.00	0.00	100.00
>11	0.00	100.00	0.00	0.00	0.01	0.00	0.00	0.00	0.00	0.00	100.00

FREQUENCY DISTRIBUTIONS OF THE LONGITUDINAL COMPONENT TIME SCALE AT THE  
LAKE UNION 48.2 M LEVEL BY WIND SPEED

SPEED (M/SEC)	0.0-2.0	2.0-4.0	4.0-6.0	6.0-8.0	8.0-10.0	10.0-12.0	12.0-14.0	14.0-16.0	16.0-18.0	>18.0	TOTAL
<1	.07	.14	.28	1.03	.68	1.10	.69	.28	.28	1.24	5.57
1-3	.03	1.12	3.85	5.78	6.74	5.16	3.92	2.54	2.13	3.37	35.28
3-5	6.06	1.17	4.26	6.05	5.91	5.02	2.27	2.27	1.38	2.96	31.29
5-7	6.60	1.63	2.86	3.78	2.87	3.71	1.99	1.03	.89	1.10	19.33
7-9	.07	.34	.06	1.31	1.38	1.03	.28	.41	.28	.21	6.26
9-11	0.60	.14	.21	.41	.21	.34	.28	.07	0.00	.07	1.72
>11	.07	.07	.07	0.60	.14	0.00	0.00	.07	.07	.07	.55
	.24	4.61	17.56	18.30	17.68	16.37	9.42	6.67	5.02	9.01	

G-11

TOTAL NO. OF OBSERVATIONS USED IN THIS TABLE = 1454.

SPEED (M/SEC)	0.0-2.0	2.0-4.0	4.0-6.0	6.0-8.0	8.0-10.0	10.0-12.0	12.0-14.0	14.0-16.0	16.0-18.0	>18.0	TOTAL
<1	1.23	2.47	4.64	16.52	6.64	19.75	12.35	4.94	4.94	22.22	100.00
1-3	.10	4.07	16.97	16.37	19.10	14.62	11.11	7.21	6.04	9.55	100.00
3-5	6.03	1.74	13.43	19.34	16.40	16.04	7.25	7.25	4.40	9.45	100.00
5-7	0.60	2.16	15.16	19.57	14.59	19.22	10.32	5.34	4.63	5.69	100.00
7-9	1.10	2.49	15.16	20.88	21.08	16.48	4.40	6.59	4.40	3.30	100.00
9-11	0.60	4.00	12.00	24.00	12.00	20.00	16.00	4.00	0.00	4.00	100.00
>11	12.50	12.50	12.50	6.00	25.00	0.00	0.00	12.50	12.50	12.50	100.00

FREQUENCY DISTRIBUTIONS OF THE LATERAL COMPONENT TIME SCALE AT THE LAKE  
UNION 48.2 m LEVEL BY WIND SPEED

SPEED (M/SEC)	0.0-2.0	2.0-4.0	4.0-6.0	6.0-8.0	8.0-10.0	10.0-12.0	12.0-14.0	14.0-16.0	16.0-18.0	>18.0	TOTAL
<1	0.60	0.60	.34	.83	1.17	.89	.41	.62	.34	.96	5.57
1-3	.71	1.10	5.16	7.98	6.74	5.09	3.23	2.06	1.24	2.48	35.28
3-5	0.89	3.16	8.50	6.53	5.57	3.03	1.79	.89	.76	1.10	31.29
5-7	2.54	4.46	6.46	2.96	1.51	1.38	.89	.55	.14	.55	19.33
7-9	1.85	1.79	1.71	.55	.21	.48	.14	0.00	.07	.07	6.26
9-11	.71	.68	.68	.26	.14	.14	0.00	0.00	0.00	0.00	1.72
>11	.07	0.00	.23	.07	.07	0.00	0.00	.07	0.00	.07	.55
	4.68	10.94	26.36	19.19	15.41	11.00	6.66	4.20	2.54	5.23	

TOTAL % OF OBSERVATIONS USED IN THIS TABLE 1456.

SPEED (M/SEC)	0.0-2.0	2.0-4.0	4.0-6.0	6.0-8.0	8.0-10.0	10.0-12.0	12.0-14.0	14.0-16.0	16.0-18.0	>18.0	TOTAL
<1	0.00	0.00	2.17	14.81	20.99	16.05	7.61	11.11	6.17	17.26	100.00
1-3	.54	3.12	14.62	22.61	19.10	14.62	9.16	5.85	3.51	7.02	100.00
3-5	0.20	10.11	27.03	20.88	17.80	9.67	5.71	2.86	2.42	3.52	100.00
5-7	17.17	20.78	22.78	15.30	7.63	7.12	4.63	2.85	.71	2.85	100.00
7-9	24.37	28.57	20.88	8.79	3.35	7.69	2.28	0.00	1.10	1.10	100.00
9-11	12.00	24.00	24.00	16.00	6.00	8.00	0.00	0.00	0.00	0.00	100.00
>11	12.50	0.00	17.50	12.50	12.50	0.00	0.00	12.50	0.00	12.50	100.00

FREQUENCY DISTRIBUTIONS OF THE VERTICAL COMPONENT TIME SCALE AT THE LAKE  
UNION 48.2 m LEVEL BY WIND SPEED

SPEED (M/SEC)	0.0-1.0	1.0-2.0	2.0-3.0	3.0-4.0	4.0-5.0	5.0-6.0	6.0-7.0	7.0-8.0	8.0-9.0	>9.0	TOTAL
<1	.29	.21	0.00	.41	.14	.69	.41	.28	.69	2.48	5.57
1-3	.07	0.00	1.10	2.96	3.44	3.92	4.27	3.30	2.00	14.25	35.31
3-5	0.00	.48	1.65	4.54	4.82	4.47	3.30	2.13	3.03	6.88	31.31
5-7	.34	2.68	3.65	3.92	2.34	1.93	1.45	.89	.96	1.10	9.27
7-9	.07	2.20	1.72	.76	.4	.34	.28	.28	.14	.97	6.26
9-11	0.00	.28	.83	.14	.21	.07	.07	.07	.07	0.00	1.72
>11	.07	0.00	0.00	.34	.14	0.00	0.00	0.00	0.00	0.00	.55
	.83	5.85	8.95	13.08	11.41	11.42	9.77	6.95	6.88	24.78	

TOTAL NO. OF OBSERVATIONS USED IN THIS TABLE = 1453.

SPEED (M/SEC)	0.0-1.0	1.0-2.0	2.0-3.0	3.0-4.0	4.0-5.0	5.0-6.0	6.0-7.0	7.0-8.0	8.0-9.0	>9.0	TOTAL
<1	4.94	3.70	0.00	7.41	2.47	12.35	7.41	4.94	12.35	44.44	100.00
1-3	.19	0.00	3.12	8.38	9.75	11.11	12.09	9.36	5.65	40.35	100.00
3-5	0.00	1.54	5.27	14.51	15.31	14.29	10.55	6.81	9.67	21.98	100.00
5-7	1.79	13.93	18.93	20.36	12.14	10.00	7.50	4.64	5.00	5.71	100.00
7-9	1.10	35.16	27.47	12.09	6.59	5.49	4.40	4.40	2.20	1.10	100.00
9-11	0.00	16.00	48.00	8.00	12.00	4.00	4.00	4.00	4.00	0.00	100.00
>11	12.50	0.00	0.00	62.50	25.00	0.00	0.00	0.00	0.00	0.00	100.00

FREQUENCY DISTRIBUTIONS OF THE LONGITUDINAL COMPONENT TIME SCALE AT THE  
KIXI 77.1 m LEVEL BY WIND SPEED

SPEED (M/SEC)	0.0-2.0	2.0-4.0	4.0-6.0	6.0-8.0	8.0-10.	10.-12.	12.-14.	14.-16.	16.-18.	>18.	TOTAL
<1	0.00	.13	.75	.50	1.00	1.25	1.13	.50	.75	.63	6.64
1-3	0.00	.63	5.39	7.77	6.27	5.64	4.26	2.63	2.76	3.51	41.10
3-5	0.00	1.38	5.89	6.02	6.27	5.64	3.26	1.75	1.25	2.01	35.46
5-7	0.00	.25	2.51	2.76	1.36	1.68	1.25	.75	.25	.63	11.65
7-9	0.00	.63	1.75	1.38	.13	.50	.13	0.00	0.00	0.00	4.51
9-11	0.00	0.00	.50	.13	0.00	0.00	0.00	0.00	0.00	0.00	.63
>11	6.60	0.00	0.00	0.00	0.01	0.00	0.00	0.00	0.00	0.00	0.00
	0.00	3.26	16.79	20.55	17.01	14.91	10.03	5.64	5.01	6.77	

TOTAL NO. OF OBSERVATIONS USED IN THIS TABLE = 798.

SPEED (M/SEC)	0.0-2.0	2.0-4.0	4.0-6.0	6.0-8.0	8.0-10.	10.-12.	12.-14.	14.-16.	16.-18.	>18.	TOTAL
<1	0.00	1.89	11.32	7.55	15.09	16.67	16.98	7.55	11.32	9.43	100.00
1-3	0.00	2.13	13.11	18.90	20.12	13.72	10.37	6.40	6.71	6.54	100.00
3-5	0.00	3.89	16.61	22.61	17.67	15.90	9.19	4.95	3.53	5.65	100.00
5-7	0.00	2.15	21.51	23.66	11.83	16.13	10.75	6.45	2.15	5.38	100.00
7-9	0.00	13.59	38.69	30.56	2.78	11.11	2.78	0.00	0.00	0.00	100.00
9-11	0.00	0.00	60.00	20.00	0.01	0.00	0.00	0.00	0.00	0.00	100.00
>11	0.00	0.00	0.00	0.00	0.01	0.00	0.00	0.00	0.00	0.00	0.00

FREQUENCY DISTRIBUTIONS OF THE LATERAL COMPONENT TIME SCALE AT THE KIXI  
77.1 m LEVEL BY WIND SPEED

SPEED (M/SEC)	0.0-2.0	2.0-4.0	4.0-6.0	6.0-8.0	8.0-10.0	10.-12.	12.-14.	14.-16.	16.-18.	>18.	TOTAL
<1	.25	.63	1.26	1.38	.75	.75	.38	.50	.38	.13	6.41
1-3	.50	2.64	6.67	7.66	7.66	5.15	3.77	2.89	1.13	1.13	41.21
3-5	0.00	2.89	11.61	6.04	5.28	2.76	2.64	.88	.75	.50	35.55
5-7	.13	2.26	4.02	2.39	1.01	1.13	.63	.13	0.00	0.00	11.68
7-9	0.00	1.51	1.76	.63	.38	0.00	.13	.13	0.00	0.00	4.52
9-11	0.00	.25	.13	.13	.13	0.00	0.00	0.00	0.00	0.00	.63
>11	0.00	0.00	0.00	0.00	0.00	0.00	0.00	0.00	0.00	0.00	0.00
	.88	10.18	27.64	20.23	15.20	9.80	7.84	4.52	2.26	1.76	

TOTAL NO. OF OBSERVATIONS USED IN THIS TABLE = 796.

SPEED (M/SEC)	0.0-2.0	2.0-4.0	4.0-6.0	6.0-8.0	8.0-10.0	10.-12.	12.-14.	14.-16.	16.-18.	>18.	TOTAL
<1	3.92	9.80	19.61	21.57	11.76	11.76	5.88	7.84	5.88	1.96	100.00
1-3	1.22	6.40	21.04	18.60	18.60	12.50	9.15	7.01	2.74	2.74	100.00
3-5	0.00	6.13	33.22	22.61	14.84	7.77	7.42	2.47	2.12	1.41	100.00
5-7	1.04	19.35	34.41	20.43	6.60	9.68	5.38	1.08	0.00	0.00	100.00
7-9	0.00	33.13	38.69	13.89	6.33	0.00	2.78	2.78	0.00	0.00	100.00
9-11	0.00	40.00	20.00	20.00	20.00	0.00	0.00	0.00	0.00	0.00	100.00
>11	0.00	0.00	0.00	0.00	0.00	0.00	0.00	0.00	0.00	0.00	0.00

FREQUENCY DISTRIBUTIONS OF THE VERTICAL COMPONENT TIME SCALE AT THE KIXI  
77.1 m LEVEL BY WIND SPEED

SPEED (M/SEC)	0.0-1.0	1.0-2.0	2.0-3.0	3.0-4.0	4.0-5.0	5.0-6.0	6.0-7.0	7.0-8.0	8.0-9.0	TOTAL
<1	0.00	0.00	.25	.25	.68	1.51	.68	.50	.63	9.0
1-3	0.00	0.00	2.01	5.65	6.90	5.77	5.41	3.76	1.76	1.76
3-5	0.00	.50	3.14	6.52	6.78	4.39	4.27	2.63	2.01	5.27
5-7	.13	.63	2.63	2.63	2.76	1.00	.25	.75	.50	.25
7-9	0.00	1.38	1.88	.63	.13	.38	0.00	0.00	0.00	13
9-11	0.00	.38	.13	.13	0.00	0.00	0.00	0.00	0.00	0.00
>11	0.00	0.00	0.00	0.00	0.00	0.90	0.00	0.00	0.00	0.00
	.13	2.89	10.04	15.61	17.14	13.05	10.79	7.65	4.89	17.31

TOTAL NO. OF OBSERVATIONS USED IN THIS TABLE = 797.										
SPEED (M/SEC)	0.0-1.0	1.0-2.0	2.0-3.0	3.0-4.0	4.0-5.0	5.0-6.0	6.0-7.0	7.0-8.0	8.0-9.0	TOTAL
<1	0.00	0.00	3.77	3.77	13.21	22.64	13.21	7.55	9.43	>9.0
1-3	0.00	0.00	4.68	13.72	16.77	14.02	13.11	9.15	4.27	26.42
3-5	0.00	1.41	6.83	18.37	19.18	12.37	12.01	7.42	5.65	24.09
5-7	1.09	5.43	22.83	22.83	13.91	8.70	2.17	6.52	4.35	14.84
7-9	0.00	30.56	41.61	13.89	2.18	6.33	0.00	0.00	0.00	2.17
9-11	0.00	60.00	20.00	20.00	9.00	0.00	0.00	0.00	0.00	2.78
>11	0.00	0.00	0.00	0.00	0.00	0.00	0.00	0.00	0.00	0.00
	0.00	9.60	0.00	0.00	0.69	0.00	0.00	0.00	0.00	0.00

FREQUENCY DISTRIBUTIONS OF THE LONGITUDINAL COMPONENT TIME SCALE AT THE  
KIXI 95.4 m LEVEL BY WIND SPEED

SPEED (M/SEC)	0.0-2.0	2.0-4.0	4.0-6.0	6.0-8.0	8.0-10.0	10.-12	12.-14	14.-16	16.-18	>18	TOTAL
<1	0.00	.13	.39	2.19	1.29	.90	.77	1.16	.51	1.16	8.48
1-3	0.00	1.93	6.17	9.77	9.13	5.01	5.40	2.44	1.03	3.34	44.22
3-5	.13	1.60	7.33	8.10	5.78	4.37	1.54	2.06	.77	2.31	34.19
5-7	0.00	.90	2.83	2.70	1.16	1.54	.64	.51	.39	.13	10.80
7-9	0.00	.39	.39	.64	.26	0.00	.13	.13	.13	0.00	2.06
9-11	0.00	.13	0.00	.13	0.30	0.00	0.00	0.00	0.00	0.00	.26
>11	0.00	0.00	0.00	0.00	0.30	7.00	0.00	0.00	0.00	0.00	9.00
	.13	5.27	17.10	23.52	17.61	.83	8.48	6.30	2.83	6.74	

TOTAL NO. OF OBSERVATIONS USED IN THIS TABLE = 778.

SPEED (M/SEC)	0.0-2.0	2.0-4.0	4.0-6.0	6.0-8.0	8.0-10.0	10.-12	12.-14	14.-16	16.-18	>18	TOTAL
<1	0.00	1.52	4.55	25.76	15.15	10.61	9.09	13.64	6.06	13.64	100.00
1-3	0.00	4.36	13.95	22.09	20.64	11.34	12.21	5.52	2.33	7.56	100.00
3-5	.38	5.26	21.43	23.68	16.92	12.78	4.51	6.04	2.26	6.77	100.00
5-7	0.00	6.33	26.19	25.00	10.71	14.29	5.95	4.76	3.57	1.19	100.00
7-9	0.00	18.75	18.75	31.25	12.50	0.00	6.25	6.25	6.25	0.00	100.00
9-11	0.00	50.00	0.00	50.00	0.00	0.00	0.00	0.00	0.00	0.00	100.00
>11	0.00	0.00	0.00	0.00	0.00	0.00	0.00	0.00	0.00	0.00	0.00

FREQUENCY DISTRIBUTIONS OF THE LATERAL COMPONENT TIME SCALE AT THE KIXI  
95.4 m LEVEL BY WIND SPEED

SPEED (M/SEC)	0.0-2.0	2.0-4.0	4.0-6.0	6.0-8.0	8.0-10.	10.-12.	12.-14.	14.-16.	16.-18.	>18.	TOTAL
<1	0.00	.43	1.41	1.80	1.29	1.03	1.03	1.03	.51	.26	8.48
1-3	.13	2.17	8.61	10.41	6.43	6.04	2.83	1.93	1.67	1.93	44.22
3-5	0.00	5.27	10.03	7.64	4.75	2.70	2.31	.39	.64	.26	34.19
5-7	.13	2.31	3.34	2.44	1.03	.90	.13	.26	.13	.13	10.60
7-9	0.00	.13	1.16	.26	.23	.13	0.00	0.00	0.00	.13	2.06
9-11	0.00	.13	0.00	.13	0.00	0.00	0.00	0.00	0.00	0.00	.26
>11	0.00	0.00	0.00	0.00	0.00	0.00	0.00	0.00	0.00	0.00	0.00
	.26	10.15	24.55	22.88	15.81	10.80	6.30	3.60	2.96	2.70	

TOTAL NO. OF OBSERVATIONS USED IN THIS TABLE = 778.

SPEED (M/SEC)	0.0-2.0	2.0-4.0	4.0-6.0	6.0-8.0	8.0-10.	10.-12.	12.-14.	14.-16.	16.-18.	>18.	TOTAL
<1	0.00	1.52	16.67	21.21	15.15	12.12	12.12	12.12	6.06	3.03	100.00
1-3	.29	4.94	19.48	23.55	19.19	13.66	6.40	4.36	3.76	4.36	100.00
3-5	0.66	15.41	29.32	22.93	13.91	7.89	6.77	1.13	1.68	.75	100.00
5-7	1.19	21.43	30.95	22.62	9.52	6.33	1.19	2.38	1.19	1.19	100.00
7-9	0.00	6.25	56.25	12.50	12.50	6.25	0.68	0.00	0.00	6.25	100.00
9-11	0.66	50.00	0.00	50.00	0.00	0.00	0.00	0.00	6.00	0.00	100.00
>11	0.66	0.00	0.00	0.00	0.00	0.00	0.00	0.00	0.00	0.00	0.00

FREQUENCY DISTRIBUTIONS OF THE VERTICAL COMPONENT TIME SCALE AT THE KIXI  
95.4 m LEVEL BY WIND SPEED

SPEED (M/SEC)	0.0-1.0	1.0-2.0	2.0-3.0	3.0-4.0	4.0-5.0	5.0-6.0	6.0-7.0	7.0-8.0	8.0-9.0	>9.0	TOTAL
<1	0.00	.26	.26	.26	.26	.77	.90	.64	.77	4.38	8.49
1-3	.26	0.00	.77	2.70	4.38	4.38	5.53	4.89	3.86	17.50	44.27
3-5	0.00	.13	2.83	4.38	7.21	5.41	3.22	2.32	2.96	5.79	34.23
5-7	0.00	.13	1.29	3.35	1.93	1.67	.90	.26	.51	.77	10.81
7-9	0.00	.13	.77	.51	.33	.13	0.00	.13	0.00	0.00	2.06
9-11	0.00	0.00	0.00	.13	0.00	0.00	0.00	0.00	0.00	0.00	.13
>11	0.00	0.00	0.00	0.00	0.00	0.00	0.00	0.00	0.00	0.00	0.00
	.26	.64	5.92	11.33	14.11	12.36	10.55	9.24	8.11	28.44	

TOTAL NO. OF OBSERVATIONS USED IN THIS TABLE = 777.

SPEED (M/SEC)	0.0-1.0	1.0-2.0	2.0-3.0	3.0-4.0	4.0-5.0	5.0-6.0	6.0-7.0	7.0-8.0	8.0-9.0	>9.0	TOTAL
<1	0.00	3.03	3.03	3.03	3.03	9.09	10.61	7.58	9.09	51.52	100.00
1-3	.58	0.00	1.74	6.10	9.88	9.88	12.50	11.05	8.72	39.53	100.00
3-5	0.00	.35	6.27	12.78	21.05	15.79	9.40	6.77	8.65	16.92	100.00
5-7	0.00	1.19	11.90	30.95	17.86	15.48	8.33	2.38	4.76	7.14	100.00
7-9	0.00	6.25	37.50	25.00	18.75	6.25	0.00	6.25	0.00	0.00	100.00
9-11	0.00	0.00	0.00	100.00	0.00	0.00	0.00	0.00	0.00	0.00	100.00
>11	0.00	0.00	0.00	0.00	0.00	0.00	0.00	0.00	0.00	0.00	0.00

FREQUENCY DISTRIBUTIONS OF THE LONGITUDINAL COMPONENT TIME SCALE AT THE  
SEA-TAC 7.1 m LEVEL BY WIND SPEED

SPEED (M/SEC)	0.0-2.0	2.0-4.0	4.0-6.0	6.0-8.0	8.0-10.0	10.-12.	12.-14.	14.-16.	16.-18.	>18.	TOTAL
<1	0.00	.39	2.17	1.08	1.18	.99	.39	.39	.69	.89	8.09
1-3	.10	5.33	9.37	9.57	9.37	6.21	4.83	2.47	2.27	3.65	53.35
3-5	0.00	2.96	7.00	5.82	5.13	2.96	1.68	.89	.99	.99	28.40
5-7	.18	1.08	1.97	1.48	1.48	.89	.79	.30	.20	.20	6.48
7-9	0.00	.30	.69	.20	.30	.10	0.00	0.00	0.00	0.00	1.58
9-11	0.00	0.00	.10	0.00	0.00	0.00	0.00	0.00	0.00	0.00	.10
>11	0.00	0.00	0.00	0.00	0.00	0.00	0.00	0.00	0.00	0.00	0.00
	.20	10.06	21.30	18.15	17.15	11.14	7.69	4.04	4.14	5.92	

TOTAL NO. OF OBSERVATIONS USED IN THIS TABLE = 1014.

SPEED (M/SEC)	0.0-2.0	2.0-4.0	4.0-6.0	6.0-8.0	8.0-10.0	10.-12.	12.-14.	14.-16.	16.-18.	>18.	TOTAL
<1	0.00	4.88	26.83	13.41	13.41	12.20	4.88	4.88	8.54	10.98	100.00
1-3	.18	9.98	17.56	17.93	17.56	11.65	9.06	4.62	4.25	7.21	100.00
3-5	0.00	10.42	24.65	20.49	18.36	10.42	5.90	3.13	3.47	3.47	100.00
5-7	1.16	12.79	23.26	17.44	17.44	10.47	9.30	3.49	2.33	2.33	100.00
7-9	0.00	18.75	43.75	12.50	18.75	6.25	0.00	0.00	0.00	0.00	100.00
9-11	0.00	0.00	100.00	0.00	0.10	0.00	0.00	0.00	0.00	0.00	100.00
>11	0.00	0.00	0.00	0.00	0.10	0.00	0.00	0.00	0.00	0.00	0.00

FREQUENCY DISTRIBUTIONS OF THE LATERAL COMPONENT TIME SCALE AT THE SEA-TAC  
7.1 m LEVEL BY WIND SPEED

SPEED (M/SEC)	0.0-2.0	2.0-4.0	4.0-6.0	6.0-8.0	8.0-10.	10.-12.	12.-14.	14.-16.	16.-18.	>18.	TOTAL
<1	.20	1.18	1.87	.79	1.08	.99	.39	.39	.30	.89	8.09
1-3	1.18	8.78	11.64	8.88	7.58	4.83	3.65	1.97	1.78	3.16	53.35
3-5	.40	6.31	7.79	5.33	3.45	2.37	1.08	.59	.30	.69	28.40
5-7	.79	2.17	2.37	1.97	.58	.49	.10	0.00	0.00	0.00	8.48
7-9	.18	.39	.49	.20	.30	0.00	.10	0.00	0.00	0.00	1.58
9-11	0.00	0.00	0.00	.10	0.00	0.00	0.00	0.00	0.00	0.00	.10
>11	0.00	0.00	0.00	0.00	0.00	0.00	0.00	0.00	0.00	0.00	0.00
	2.37	18.84	24.16	17.26	13.23	8.68	5.33	2.96	2.37	4.73	

TOTAL NO. OF OBSERVATIONS USED IN THIS TABLE = 1014.

SPEED (M/SEC)	0.0-2.0	2.0-4.0	4.0-6.0	6.0-8.0	8.0-10.	10.-12.	12.-14.	14.-16.	16.-18.	>18.	TOTAL
<1	2.44	14.63	23.17	9.76	13.41	12.20	4.88	4.88	3.66	16.98	100.00
1-3	2.22	16.45	21.81	16.64	14.05	9.06	6.84	3.70	3.33	5.91	100.00
3-5	1.74	22.22	27.43	18.75	12.15	8.33	3.82	2.08	1.04	2.43	100.00
5-7	4.65	15.58	27.91	23.26	11.63	5.81	1.16	0.00	0.00	0.00	100.00
7-9	6.25	25.00	31.25	12.50	18.75	0.00	6.25	0.00	0.00	0.00	100.00
9-11	0.00	0.00	0.00	0.00	0.00	0.00	0.00	0.00	0.00	0.00	100.00
>11	0.00	0.00	0.00	0.00	0.00	0.00	0.00	0.00	0.00	0.00	0.00

FREQUENCY DISTRIBUTIONS OF THE VERTICAL COMPONENT TIME SCALE AT THE SEA-TAC  
7.1 m LEVEL BY WIND SPEED

SPEED (M/SEC)	0.0-1.0	1.0-2.0	2.0-3.0	3.0-4.0	4.0-5.0	5.0-6.0	6.0-7.0	7.0-8.0	8.0-9.0	>9.0	TOTAL
<1	1.59	1.10	1.00	.90	.80	.50	.80	0.00	.30	.60	7.57
1-3	2.19	4.98	12.25	12.25	8.17	5.78	2.69	2.59	1.39	1.20	53.49
3-5	0.00	6.27	9.86	7.07	3.09	.90	.70	.50	.10	.20	28.69
5-7	.30	3.29	3.39	.90	.40	0.00	.20	0.00	0.00	.10	8.57
7-9	0.00	.80	.50	.10	.10	.10	0.00	0.00	0.00	0.00	1.59
9-11	0.00	.10	0.00	0.00	0.00	0.00	0.00	0.00	0.00	0.00	.10
>11	0.30	0.00	0.00	0.00	0.00	0.00	0.00	0.00	0.00	0.00	0.00
	4.08	16.53	26.99	21.22	12.55	7.27	4.38	3.09	1.79	2.09	

TOTAL NO. OF OBSERVATIONS USED IN THIS TABLE = 1004.

SPEED (M/SEC)	0.0-1.0	1.0-2.0	2.0-3.0	3.0-4.0	4.0-5.0	5.0-6.0	6.0-7.0	7.0-8.0	8.0-9.0	>9.0	TOTAL
<1	21.05	14.47	13.16	11.84	10.53	6.58	10.53	0.00	3.95	7.89	100.00
1-3	4.10	9.31	22.91	22.91	15.27	10.80	5.03	4.84	2.61	2.23	100.00
3-5	0.00	21.88	34.38	24.65	10.76	3.13	2.43	1.74	.35	.69	100.00
5-7	3.40	38.37	39.53	10.67	4.65	0.00	2.33	0.00	0.00	1.16	100.00
7-9	0.00	50.00	31.25	6.25	6.25	6.25	0.00	0.00	0.00	0.00	100.00
9-11	0.00	100.00	0.00	0.00	0.00	0.00	0.00	0.00	0.00	0.00	100.00
>11	0.00	0.00	0.00	0.00	0.00	0.00	0.00	0.00	0.00	0.00	0.00

FREQUENCY DISTRIBUTIONS OF THE LONGITUDINAL COMPONENT TIME SCALE AT THE  
SEA-TAC 27.0 m LEVEL BY WIND SPEED

SPEED (M/SEC)	0.0-.0	2.0-4.0	4.0-6.0	6.0-8.0	8.0-11.	10.-12.	12.-14.	14.-16.	16.-18.	>18.	TOTAL
<1	.30	.60	.20	.60	.10	.40	.40	.40	.20	.30	3.77
1-3	.70	3.67	7.85	10.03	6.74	5.46	3.67	3.08	1.69	2.09	47.17
3-5	0.00	2.18	7.55	7.65	4.07	3.57	2.88	2.18	1.09	1.09	32.87
5-7	.10	.70	3.38	3.48	1.39	1.69	.79	1.09	.20	.30	13.01
7-9	0.00	.20	.60	.79	.40	.30	.10	0.00	.10	.10	2.58
9-11	0.00	0.00	.20	.20	.10	0.00	0.00	.10	0.00	0.00	.60
>11	0.00	0.00	0.00	0.00	0.10	0.00	0.00	0.00	0.00	0.00	0.00
	1.09	7.35	19.76	22.54	15.79	11.42	8.04	6.65	3.28	3.87	

TOTAL NO. OF OBSERVATIONS USED IN THIS TABLE = 1007.

SPEED (M/SEC)	0.0-2.0	2.0-4.0	4.0-6.0	6.0-8.0	8.0-11.	10.-12.	12.-14.	14.-16.	16.-18.	>18.	TOTAL
<1	7.89	15.79	5.26	15.79	10.53	10.53	10.53	10.53	5.26	7.89	100.00
1-3	1.47	7.79	16.63	21.26	19.13	11.58	8.21	6.53	3.58	4.42	100.00
3-5	0.00	6.65	22.96	22.66	14.10	10.80	8.76	6.65	3.32	3.32	100.00
5-7	.76	5.34	25.95	26.72	9.72	12.98	6.11	6.40	1.53	2.29	100.00
7-9	0.00	7.69	23.08	30.77	15.18	11.54	3.85	0.00	3.85	3.85	100.00
9-11	0.00	0.00	33.33	33.33	16.17	0.00	0.00	16.67	0.00	0.00	100.00
>11	0.00	0.00	0.00	0.00	0.10	0.00	0.00	0.00	0.00	0.00	0.00

FREQUENCY DISTRIBUTIONS OF THE LATERAL COMPONENTS OF WIND SPEED AT THE SEA-TAC  
27.0 m LEVEL BY WIND SPEED

SPEED (M/SEC)	0.0-2.0	2.0-4.0	4.0-6.0	6.0-8.0	8.0-10.0	10.-12.	12.-14.	14.-16.	16.-18.	>18.	TOTAL
<1	.30	.20	.10	.40	.40	.40	.70	.40	.30	.60	3.77
1-3	1.09	7.45	10.82	6.34	6.26	4.67	2.48	1.69	1.89	2.48	47.17
3-5	.50	7.65	10.82	6.36	3.28	1.19	1.19	.60	.50	.79	32.87
5-7	.70	4.47	3.87	1.39	1.39	.60	.30	.10	0.00	.20	13.01
7-9	.10	1.39	.60	.30	.20	0.00	0.00	0.00	0.00	0.00	2.58
9-11	0.00	.20	.30	.10	0.20	0.00	0.00	0.00	0.00	0.00	.60
>11	0.00	0.00	0.00	0.00	0.00	0.00	0.00	2.00	0.00	0.00	0.00
	2.68	21.35	26.51	16.88	11.12	6.85	4.67	2.78	2.68	4.07	

TOTAL NO. OF OBSERVATIONS USED IN THIS TABLE = 1007.

SPEED (M/SEC)	0.0-2.0	2.0-4.0	4.0-6.0	6.0-8.0	8.0-10.0	10.-12.	12.-14.	14.-16.	16.-18.	>18.	TOTAL
<1	7.89	5.26	2.63	10.53	10.53	10.53	18.42	10.53	7.89	15.79	100.00
1-3	2.32	15.79	22.95	17.68	13.26	9.89	5.26	3.58	4.00	5.26	100.00
3-5	1.51	23.26	32.93	19.34	9.97	3.63	3.63	1.61	1.51	2.42	100.00
5-7	5.34	34.35	29.77	10.69	10.69	4.58	2.29	.76	0.00	1.53	100.00
7-9	3.45	53.45	23.02	11.54	7.69	0.00	0.00	0.00	0.00	0.00	100.00
9-11	0.00	33.33	50.00	16.67	0.00	0.00	0.00	0.00	0.00	0.00	100.00
>11	0.00	0.00	0.00	0.00	0.30	0.00	0.00	0.00	0.00	0.00	0.00

FREQUENCY DISTRIBUTIONS OF THE VERTICAL COMPONENT TIME SCALE AT THE SEA-TAC  
27.0 m LEVEL BY WIND SPEED

SPEED (M/SEC)	0.0-1.0	1.0-2.0	2.0-3.0	4.0-4.0	4.0-5.0	5.0-6.0	6.0-7.0	7.0-8.0	8.0-9.0	>9.0	TOTAL
<1	.30	.40	.40	.20	.10	0.00	.20	.20	0.00	1.00	2.91
1-3	2.61	1.81	5.72	7.33	6.33	5.32	3.61	3.31	3.11	7.83	47.49
3-5	.10	2.71	7.23	7.53	4.52	3.92	2.31	1.61	.70	2.41	33.23
5-7	0.00	1.81	4.72	2.61	1.11	1.31	.10	.30	.10	.20	13.15
7-9	0.00	.50	1.10	.50	.20	.20	0.00	.10	0.00	0.00	2.61
9-11	0.00	.10	.30	0.00	.10	.10	0.00	0.00	0.00	0.00	.60
>11	0.00	0.00	0.00	0.00	0.10	0.00	0.00	0.00	0.00	0.00	0.00
	3.01	7.33	19.48	18.37	13.11	10.84	6.22	5.72	3.92	11.45	

TOTAL NO. OF OBSERVATIONS USED IN THIS TABLE = 996.

SPEED (M/SEC)	0.0-1.0	1.0-2.0	2.0-3.0	4.0-4.0	4.0-5.0	5.0-6.0	6.0-7.0	7.0-8.0	8.0-9.0	>9.0	TOTAL
<1	10.36	13.79	13.79	6.99	6.70	0.00	5.90	6.90	0.00	34.48	100.00
1-3	5.50	3.81	12.05	15.43	14.18	11.21	7.61	6.98	6.55	16.49	100.00
3-5	.30	8.16	21.75	22.65	13.49	11.78	6.95	5.44	2.11	7.25	100.00
5-7	0.00	13.74	35.68	21.37	13.74	9.92	.76	2.29	.76	1.53	100.00
7-9	0.00	19.23	42.31	19.23	7.69	7.69	0.00	3.85	0.00	0.00	100.00
9-11	0.00	16.67	50.00	0.00	16.67	16.67	0.00	0.00	0.00	0.00	100.00
>11	0.00	0.00	0.00	0.00	0.00	0.00	0.00	0.00	0.00	0.00	0.00