

AFML-TR-75-41
Volume II

22

FB

RESEARCH ON DEEP HARDENING TITANIUM ALLOY FOR LARGE AIRFRAME STRUCTURAL MEMBERS

ADA019362

Colt Industries/Crucible Inc
Crucible Materials Research Center
Rockwell International Science Center

DDC
RECEIVED
JAN 16 1976
A

TECHNICAL REPORT AFML-TR-75-41, VOLUME II

September, 1975

Final Report for Period May 1971 - October 1974

Approved for public release; distribution unlimited.

Prepared for

Air Force Materials Laboratory
Air Force Systems Command
Wright-Patterson Air Force Base, Ohio

NOTICE

When Government drawings, specifications, or other data are used for any purpose other than in connection with a definitely related Government procurement operation, the United States Government thereby incurs no responsibility nor any obligation whatsoever; and the fact that the government may have formulated, furnished, or in any way supplied the said drawings, specifications, or other data is not to be regarded by implication or otherwise as in any manner licensing the holder or any other person or corporation, or conveying any rights or permission to manufacture, use or sell any patented invention that may in any way be related thereto.

This report has been reviewed by the Information Office (OI) and is releasable to the National Technical Information Service (NTIS). At NTIS, it will be available to the general public, including foreign nations.

This technical report has been reviewed and is approved for publication.

James A. Hall

James A. Hall
Project Engineer
High Strength Metals Group

Michael A. Greenfield

Michael A. Greenfield
Project Engineer
Joining Technology Group

For the Commander

Roger J. Austin

Roger J. Austin, Major, USAF
Acting Chief, Processing and High
Temperature Materials Branch
Metals and Ceramics Division
Air Force Materials Laboratory

ACCESSION for	
NTIS	White Section <input checked="" type="checkbox"/>
DOC	Full Section <input type="checkbox"/>
UNANNOUNCED	<input type="checkbox"/>
UNCLASSIFIED	
BY	
DISTRIBUTION/AVAILABILITY CODES	
Dist.	AVAIL. and/or SPECIAL
A	

Copies of this report should not be returned unless return is required by security considerations, contractual obligations, or notice on a specific document.

Unclassified

SECURITY CLASSIFICATION OF THIS PAGE (When Data Entered)

REPORT DOCUMENTATION PAGE		READ INSTRUCTIONS BEFORE COMPLETING FORM
1. REPORT NUMBER AFML-TR-75-41-VOL 2	2. GOVT ACCESSION NO.	3. RECIPIENT'S CATALOG NUMBER 9
4. TITLE (and Subtitle) RESEARCH ON DEEP HARDENING TITANIUM ALLOY FOR LARGE AIRFRAME STRUCTURAL MEMBERS. Volume II.		5. TYPE OF REPORT & PERIOD COVERED Final Report - 1 May 1971 - 15 October 1974
7. AUTHOR F.H. Froes, R.F. Malone, and V.C. Petersen, Colt Industries/Crucible Inc. C.G. Rhodes & J.C. Chesnutt and J.C. Williams, Rockwell International Science Center.		6. PERFORMING ORG. REPORT NUMBER 14 322-20-1-Vol-2 K
9. PERFORMING ORGANIZATION NAME AND ADDRESS Colt Industries/Crucible Inc, Crucible Materials Research Center Pittsburgh, Pa. 15230		8. CONTRACT OR GRANT NUMBER(s) 15 USAF F33615-71-C-1525
11. CONTROLLING OFFICE NAME AND ADDRESS Air Force Materials Laboratory Metals and Ceramics Division (AFML/LL) AFSC Wright-Patterson Air Force Base, Ohio 45433		10. PROGRAM ELEMENT PROJECT, TASK AREA & WORK UNIT NUMBERS 16 Project AF-7351 17 Task No. 735105 Work Unit 50
14. MONITORING AGENCY NAME & ADDRESS (if different from Controlling Office) 12 391P.		12. REPORT DATE 11 September 1975
16. DISTRIBUTION STATEMENT (of this Report) This document is subject to special con- trols and its transmittal to other government agencies shall be made only with prior approval of the Metals and Ceramics Division (AFML/LL), AFSC, Wright-Patterson AFB, Ohio 45433.		13. NUMBER OF PAGES 632 (2 volumes)
17. DISTRIBUTION STATEMENT (of the abstract entered in Block 20, if different from Report)		15. SECURITY CLASS. (of this report) Unclassified
18. SUPPLEMENTARY NOTES This work was carried out with Colt Industries/Crucible Inc as the primary performing organization, with Rockwell International Service Center acting as sub-contractor.		15a. DECLASSIFICATION/DOWNGRADING SCHEDULE
19. KEY WORDS (Continue on reverse side if necessary and identify by block number) Titanium Forging alloy Deep hardening alloy Airframe structure alloy Fine structure analysis Fundamental mechanisms Fracture toughness Tensile properties Creep properties Fatigue properties Time-Temperature-Transformation Characteristics		
20. ABSTRACT (Continue on reverse side if necessary and identify by block number) This is the final technical report of a contract to develop a titanium alloy capable of being hardened in section sizes significantly greater than currently available while retaining adequate toughness and tensile ductility. Work was carried out in three successive phases: Phase I in which the hardening potential at the center of a six inch section was defined for sixty alloy com- positions; Phase II in which the detailed evaluation of tensile properties and fracture toughness data of aged samples led to development of character- istic alloy trend lines for the ten most promising alloys; and finally, (cont. over)		

405 698 i

mt

Phase III in which three alloys - alloy 334 (10Mo-6Cr-2.5Al), 227 (7Mo-4Cr-2.5Al) and 253 (10Mo-8V-2.5Al) - were scaled up as 500 lb. ingots. After a study of various thermomechanical processes, the three alloys were converted to 6-inch diameter billet, duplex solution annealed and aged, and full mechanical properties evaluated. Transverse center properties of alloy 334 attained contract goals while equivalent properties for the other two alloys were very promising. Generally the alloy represents an advance in state-of-the-art deep hardenable titanium alloys. They show little edge to center variation in properties, in contrast to present commercial and semi-commercial alpha-beta alloys which are characterized by large edge to center difference. This property differential is of particular concern in considering fracture toughness since the effective fracture toughness in a heavy section is only as high as the lowest value occurring in the material.

Throughout the program close attention has been paid not only to mechanical properties but also to corresponding structural features. This has helped greatly in heat treatment design, especially in improving transverse ductility. A regression analysis of all structures studied showed on a semi-quantitative basis that a lenticular coarse alpha morphology results in relatively high toughness-low ductility, while a globular shape is associated with low toughness-high ductility. Other analyses and techniques developed during the program should aid not only future titanium alloy design, but also investigation of deep hardenable alloys in general.

FOREWORD

This report was prepared by the Crucible Materials Research Center, Crucible Inc, a wholly-owned subsidiary of Colt Industries, Pittsburgh, Pennsylvania, and the Rockwell International Science Center, Thousand Oaks, California, under USAF Contract F33615-71-C-1525. The research work was performed under Project No. 7351 "Metallic Materials" - Task No. 735105-50. The work was administered by the Metals and Ceramics Division, Air Force Materials Laboratory, Air Force Systems Command, Wright-Patterson Air Force Base, with J. A. Hall and Dr. M. A. Greenfield (AFML/LLM) as project engineers.

This report covers work conducted during the period from May 1, 1971 to October 15, 1974. The principal program participants were R. F. Malone, Technical Director-Titanium; Dr. F. H. Froes, Staff Metallurgist, and V. C. Petersen, Staff Metallurgist, from the Crucible Materials Research Center, and C. G. Rhodes, Senior Staff Associate; J. C. Chesnutt, Technical Staff, and Dr. J. C. Williams, Group Leader, Physical Metallurgy Group for the Rockwell International Science Center. Others cooperating in the project were: E. J. Dulis, President; Dr. R. C. Buehl, Manager-Vacuum Melt; C. F. Yolton, Staff Metallurgist; J. M. Capenos, Staff Microscopist, and J. J. Hauser, Staff Metallurgist, from the Crucible Materials Research Center.

The authors are particularly indebted to Dr. John P. Hirth, Professor of Metallurgy, Ohio State University, for numerous valuable discussions and suggestions on all facets of the program. The authors also wish to acknowledge the technical services of R. A. Hohowski, F. R. Shuss and E. W. Campbell at the Crucible Materials Research Center, and R. A. Spurling, P. Q. Sauers and E. H. Wright at the Rockwell International Science Center.

This technical report, comprised of two volumes, was released for publication by the authors in December, 1974. This is Volume II of the report containing the tables and illustrations. Volume I contains the text and appendices.

VOLUME II *
TABLE OF CONTENTS :

<u>Section</u>	<u>Page</u>
TABLES ;	1-95
ILLUSTRATIONS . ↑	96-356

* Contents of Volume I which appear under separate cover follow.

v

PRECEDING PAGE BLANK-NOT FILMED

VOLUME I

TABLE OF CONTENTS

<u>Section</u>		<u>Page</u>
I	INTRODUCTION	1
II	PROGRAM OBJECTIVES	4
III	ALLOY DESIGN	5
IV	PHASE I PROGRAM	8
	1. Program Scope	8
	2. Experimental Work and Results	8
	A. Materials and Processing	8
	B. Time-Temperature-Transformation Determinations	9
	C. Attainable Strength Measurements	13
	3. Data Analysis and Discussion	13
	A. Overview	13
	B. Deep Hardening Potential	14
	C. Attainable Strength	15
	D. Preliminary Selection	16
	E. Solution Treatment Optimization - Initial Group	17
	F. Supplemental Group of Alloys - Selection and Screening	18
	4. Alloy Selection for Phase II	21
V	PHASE II PROGRAM	23
	1. Program Scope	23
	2. Experimental Work and Results	24
	A. Materials, Processing and Heat Treating	24
	B. Evaluation Program	25
	3. Discussion of Results	28
	A. Chemical Composition	28
	B. Density Results	29
	C. Mechanical Properties	29

TABLE OF CONTENTS cont.

<u>Section</u>	<u>Page</u>
D. Structure Characterization	30
E. Fine Structure Analysis	31
F. Fracture Surface and Crack Path Investigation	36
G. Relationship of Structural Features to Properties	37
4. Alloy Selection for Phase III	40
A. Basis for Selection	40
B. Alloy Selection	41
VI PHASE III PROGRAM	45
1. Program Scope	45
VI.2 EXPERIMENTAL WORK AND RESULTS	46
A. Melting	46
B. Primary Forging	47
C. Evaluation of Blooms at 10.5 inch RCS	48
D. Secondary Forging	51
E. Optimization of Heat Treatment at 6-inch Stage	52
F. Final Heat Treatment of Six Inch Sections	55
G. Mechanical Properties of Six Inch Sections	56
H. Rolling to Plate and Mechanical Properties	57
I. Directionality in Billet and Plate	58
J. Structural Evaluation	58
VI.3 DISCUSSION OF RESULTS	61
A. Chemical and Physical Properties and Forgeability Characteristics	61
B. Mechanical Properties of Final Product	63

TABLE OF CONTENTS cont.

<u>Section</u>	<u>Page</u>
VI.3.C. STRUCTURE AND RELATIONSHIP TO PROPERTIES	72
VI.4 COMPARISON OF PRESENT ALLOYS WITH CONTRACT GOALS AND STATE-OF-THE-ART ALLOYS	83
A. Comparison with Contract Goals	83
B. Comparison with Commercial and Semi-Commercial Deep Hardenable Alloys and General Philosophy of Deep Hardenable Alloys	83
VII CONCLUSIONS AND RECOMMENDATIONS	87
REFERENCES	
APPENDICES	
A. Time-Temperature-Transformation Curves	
B. Simulated Cooling Techniques and Verification	
C. Multiple Linear Regression Analysis of Phase I Data	
D. Fine Structure Analytical Techniques	
E. Statistical Analysis of the Relationship Between Composition and Toughness (K) and Ductility (RA) - Phase II Data	
F. Orientation Nomenclature Used for Plate and Billet	
G. Discussion of Choice of Conditions Evaluated by Mechanical Property Testing to Optimize TMT 10.5 inch - 6 inch	
H. Valid Fracture Toughness (K) Testing	
I. Some Theoretical Relations Between Critical Stress Intensity and Other Mechanical Properties in the Case of Contained Plastic Fracture and Evaluation of Various Models Using Experimentally Determined Data	
J. Evaluation of the Relationship of Yield Strength, Toughness and Ductility to Structural Features - Phase III Data	
K. Void Nucleation During Deformation	

LIST OF TABLES

<u>Table No.</u>	<u>Title</u>	<u>Page No.</u>
I	Compositions Screened in Phase I	1
II	Alloying Materials Used in Formulating Phase I Alloy Melts	2
III	Beta Transus and Final Rolling Temperature for Phase I Alloys	3-4
IV	Selection of Solution Treatment and Aging Cycles for Phase I - Time-Temperature-Transformation Study	5-6
V	Selection of Solution Treatment and Aging Cycles for Time-Temperature-Transformation Studies - Supplemental Alloys	7
VI	Electron Probe Partition Data for 9Mo-2½Al Containing 30% Primary Alpha Phase	8
VII	Calculated Values for Nose Temperature and Time for the Additional Phase I Alloys	9
VIII	Transformation Characteristics of Initial Phase I Alloys	10-11
IX	Transformation Characteristics of the Additional Phase I Alloys	12
X	Aged Strength and Hardness Potential for the Initial Phase I Alloys	13
XI	Summary of Aged Hardness for the Additional Phase I Alloys	14
XII	Effect of Cooling from the Annealing Temperature at a Rate Designed to Simulate that at the Center of a 6" Diameter Section on Subsequent Attainable Strength	15

LIST OF TABLES

cont.

<u>Table No.</u>	<u>Title</u>	<u>Page No.</u>
XIII	Alloys Selected for Phase II Evaluation	16
XIV	Phase II Material Used in Ingot Formulations	17
XV	Protective Coating Details	18
XVI	Temperatures for Phase II Forging and Rolling	19
XVII	Heat Treatment Cycles for Phase II Alloys	20
XVIII	Solution Treatment and Aging Cycles for Phase II Alloys	21
XIX	Phase II Evaluation Program	22
XX	Phase II Aged Mechanical Property Data Water Quenched vs. Simulated Cooled Conditions	23-24
XXI	Phase II Aged Mechanical Property Data Water Quenched Samples	25-26
XXII	Aged Dynamic Modulus Measurements of Selected Alloys	27
XXIII	Chemical Analysis of Phase II Alloys	28
XXIV	Experimentally Determined Densities of Phase II Alloys	29
XXV	Alloys for Detailed Fine Structure Analysis at North American Rockwell Science Center	30
XXVI	Summary of Fine Structure Analysis	31
XXVII	Predicted Ductility and Toughness of Phase II Alloys at Contract Yield Strength Goal	32

LIST OF TABLES

cont.

<u>Table No.</u>	<u>Title</u>	<u>Page No.</u>
XXVIII	Summary of Correlation of Properties to Microstructure of Phase II Simulated Cooled and Aged Material	33
XXIX	Relative Ranking of Ductility and Fracture Toughness Alloy Characteristic Trend Lines	34
XXX	Chemical Analysis of Phase III Alloy Additions	35
XXXI	Calculation of Anticipated Fe and O ₂ Contents of Deep Hardenable Phase III 500 lb. Ingots	36
XXXII	Chemical Analysis of Phase III Alloys at Ingot Stage	37
XXXIII	Chemical Analysis of Phase III Alloys, Butt End 10.5" RCS Stage	38
XXXIV	Alloy Density	39
XXXV	Beta Recrystallization Study	40
XXXVI	Forging Schedule for TMT Optimization to 6 Inch Diameter	41
XXXVII	Solution and Aging Treatments for TMT Optimization to 6 inch Diameter	42
XXXVIII	Mechanical Properties of Alloy 334 (10Mo-6Cr-2.5Al) After Simulated Processing from 10.5" RCS to 6" Stage	43
XXXIX	Mechanical Properties of Alloy 227 (7Mo-4Cr-2.5Al) after Simulated Processing from 10.5" RCS to 6" Stage	44

LIST OF TABLES cont.

<u>Table No.</u>	<u>Title</u>	<u>Page No.</u>
XL	Mechanical Properties of Alloy 253 (10Mo-8V-2.5Al) after Simulated Processing from 10.5" RCS to 6" Stage	45
XLI	Hardness of Alloy 334 (10Mo-6Cr-2.5Al) after Duplex Heat Treatment Cycles	46
XLII	Further Mechanical Properties of Alloy 334 (10Mo-6Cr-2.5Al) after Simulated Processing from 10.5" RCS to 6" Stage	47
XLIII	Further Mechanical Properties of Alloy 253 (10Mo-8V-2.5Al) after Simulated Processing from 10.5" RCS to 6" Stage	48
XLIV	Further Mechanical Properties of Alloy 227 (7Mo-4Cr-2.5Al) after Simulated Processing from 10.5" RCS to 6" Stage	49
XLV	Summary of TMT Optimization Study, 10.5" RCS to 6" Diameter Round	50
XLVI	Optimum TMT to Convert Blooms from 10.5" RCS to 6" Round Billets	51
XLVII	Mechanical Properties of Alloy 334 (10Mo-6Cr-2.5Al) at 6" Stage, Samples from Butt End Slices	52
XLVIII	Mechanical Properties of Alloy 227 (7Mo-4Cr-2.5Al) at 6" Stage, Samples from Butt End Slices	53
XLIX	Mechanical Properties of Alloy 253 (10Mo-8V-2.5Al) at 6" Stage, Samples from Butt End Slices	54

LIST OF TABLES

cont.

<u>Table No.</u>	<u>Title</u>	<u>Page No.</u>
L	Mechanical Properties of Alloy 334 (10Mo-6Cr-2.5Al) at 10.5" Stage, Samples from Butt End	55
LI	Mechanical Properties of Alloy 227 (7Mo-4Cr-2.5Al) at 10.5" Stage, Samples from Butt End	56
LII	Recrystallization Kinetics Study of Alloys 334 (10Mo-6Cr-2.5Al) and 227 (7Mo-4Cr-2.5Al) at 6" Billet Stage	57
LIII	Mechanical Properties of Alloy 334 (10Mo-6Cr-2.5Al) at 6" Stage, Supra-Transus Recrystallized Prior to Heat Treatment, Samples from Butt End	58
LIV	Mechanical Properties of Alloy 227 (7Mo-4Cr-2.5Al) at 6" Stage, Supra-Transus Recrystallized Prior to Heat Treatment, Samples from Butt End	59
LV	Mechanical Properties of Alloy 227 (7Mo-4Cr-2.5Al) Given an Isothermal Treatment Prior to Aging. Samples at 6" Stage Butt End Slice.	60
LVI	Further Mechanical Properties of Alloy 227 (7Mo-4Cr-2.5Al) Given an Isothermal Treatment Prior to Aging. Samples at 6" Stage Butt End Slice	61
LVII	Additional Mechanical Properties of Alloy 227 (7Mo-4Cr-2.5Al) at 6" Stage Duplex Isothermal (High-Low) Anneal Prior to Age, Samples from Butt End	62

LIST OF TABLES cont.

<u>Table No.</u>	<u>Title</u>	<u>Page No.</u>
LVIII	Mechanical Properties of Alloy 334 (10Mo-6Cr-2.5Al) at 6" Stage, Duplex (Low-High) Anneal Prior to Age, Samples from Butt End	63
LIX	Mechanical Properties of Alloy 227 (7Mo-4Cr-2.5Al) at 6" Stage, Duplex (Low-High) Anneal Prior to Age, Samples from Butt End	64
LX	Mechanical Properties of Alloy 334(10Mo-6Cr-2.5Al) at 6" Stage, Duplex (High-Low) Anneal Prior to Age, Samples from Butt End	65
LXI	Mechanical Properties of Alloy 227 (7Mo-4Cr-2.5Al) at 6" Stage, Duplex (High-Low) Anneal Prior to Age, Samples from Butt End	66
LXII	Further Mechanical Properties of Alloy 334 (10Mo-6Cr-2.5Al) at 6" Stage, Duplex (High-Low) Anneal Prior to Age, Samples from Butt End	67
LXIII	Further Mechanical Properties of Alloy 227 (7Mo-4Cr-2.5Al) at 6" Stage, Duplex (High-Low) Anneal Prior to Age, Samples from Butt End	68
LXIV	Heat Treatment of Six Inch Billet	69
LXV	Anticipated and Goal Transverse Properties at Center of Six Inch Diameter Billet	70
LXVI	Room Temperature Tensile Precracked Charpy Toughness and Fracture Toughness Properties of Six Inch Billet of Alloy 334	71
LXVII	Room Temperature Tensile, Precracked Charpy Toughness and Fracture Toughness Properties of Six Inch Billet of Alloy 227	72

LIST OF TABLES

cont.

<u>Table No.</u>	<u>Title</u>	<u>Page No.</u>
LXVIII	Room Temperature Tensile Precracked Charpy Toughness and Fracture Toughness Properties of Six Inch Billet of Alloy 253	73
LXIX	Room and Elevated Temperature Tensile Properties - Alloy 334, 6" Billet	74
LXX	Room and Elevated Temperature Tensile Properties - Alloy 227, 6" Billet	75
LXXI	Room and Elevated Temperature Tensile Properties - Alloy 253, 6" Billet	76
LXXII	Room Temperature Tensile and Precracked Charpy Toughness Properties of 6" Billet of Alloy 334	77
LXXIII	Room Temperature Tensile and Precracked Charpy Toughness Properties of 6" Billet Alloy 227	78
LXXIV	Room Temperature Tensile and Precracked Charpy Toughness Properties of 6" Billet of Alloy 253	79
LXXV	Room Temperature Tension-Tension Fatigue Data	80
LXXVI	Creep and Creep Stability from Center Location 6 Inch Billet Tensile Samples - Alloys 334, 227 and 253	81
LXXVII	Alloy 334 Phase III Mechanical Property Data - Half Inch Plate	82
LXXVIII	Alloy 227 Phase III Mechanical Property Data - Half Inch Plate	83

LIST OF TABLES

cont.

<u>Table No.</u>	<u>Title</u>	<u>Page No.</u>
LXXIX	Alloy 253 Phase III Mechanical Property Data - Half Inch Plate	85
LXXX	Beta Matrix Texture Study for Phase III Billet and Plate	86
LXXXI	Mechanical Properties and Ductility Directionality of Alloys 334 and 227 Billet as Duplex Annealed	87
LXXXII	Phase III Structural Work: Sample Groups Evaluated	88
LXXXIII	Mechanical Properties and Corresponding Microstructural Features	89
LXXXIV	Mechanical Properties of Samples Used for Structural Analysis After a Duplex (Low-High) Aging Treatment	90
LXXXV	Forgeability of the Phase III Alloys	91
LXXXVI	Endurance Limit of Contract Alloys and Comparison with Other Potential Deep Hardenable Titanium Alloys	92
LXXXVII	Toughness-Ductility of Ti-Mo-Cr-V-Al Half Inch Plate Alloys at Goal Yield Strength Level	93
LXXXVIII	Predicted Ductility Directionality Based on the Anticipated Crack Characteristics in Plate and Billet	94
LXXXIX	Transverse Mechanical Properties of Contract Alloys in Six Inch Section Billet	95

LIST OF ILLUSTRATIONS

<u>Figure No.</u>	<u>Title</u>	<u>Page No.</u>
1	Relationship between hardness (VPN) and ultimate tensile strength (UTS) for the Phase I contract alloys.	96
2	Necessary characteristics to meet contract strength goals.	97
3-15	Variation of attainable hardness and T-T-T nose time with solution treatment temperature.	98-110
16-18	Comparison of strength potential and nose time of selected "good" alloys with contract target curve.	111-113
19-24	Transverse cross section of simulated cooled Charpy.	114-116
25	Alloy 261, ST 1450F-2 hrs, simulated cooled, aged 900F-4 hrs.	117
26	Alloy 227, ST 1400F-4 hrs, simulated cooled, aged 900F-4 hrs.	118
27	Alloy 216, ST 1300F-4 hrs, simulated cooled, aged 900F-96 hrs.	119
28	Alloy 334, ST 1325F-4 hrs, simulated cooled, aged 875F-96 hrs.	120

LIST OF ILLUSTRATIONS cont.

<u>Figure No.</u>	<u>Title</u>	<u>Page No.</u>
29	Alloy 337, ST 1350F-4 hrs, simulated cooled, aged 875-24 hrs.	121
30	Alloy 235, ST 1575F-1 hr, simulated cooled, aged 1100F-8 hrs.	122
31	Hardening response for alloys containing primary alpha and orthorhombic martensite as solution treated.	123
32	Hardening response for alloys containing primary alpha, beta and omega.	124
33	Hardening response for alloys containing primary alpha and beta.	125
34	Alloy 227, ST 1400F-4 hrs, simulated cooled, aged 900F-8 hrs.	126
35	Alloy 227, ST 1400-4 hrs, simulated cooled, aged 900F-8 hrs. Internal fracture path from Fig. 52.	127
36	Alloy 216, ST 1300F-4 hrs, simulated cooled, aged 900F-96 hrs.	128
37	Alloy 334, ST 1325F-4 hrs, simulated cooled, aged 875F-96 hrs.	129
38	Alloy 235, ST 1575-1 hr, simulated cooled, aged 1100F-8 hrs.	130
39-48	Fracture toughness-yield strength characteristic alloy trend lines. Defined using the data from Tables XX and XXI.	131-140
49-58	Ductility-yield strength characteristic alloy trend lines. Defined using the data from Tables XX and XXI.	141-150

LIST OF ILLUSTRATIONS

cont.

<u>Figure No.</u>	<u>Title</u>	<u>Page No.</u>
59	Microstructure as revealed by light microscopy in alloy 226 and alloy 227 as solution treated.	151
60	X-ray diffraction scans in the range of 34° - 40° 2θ from (a) hexagonal martensite or primary α ; (b) hexagonal martensite or primary α plus β ; (c) orthorhombic martensite (α'').	152
61	Transmission electron micrograph of alloy 227 as solution treated showing α'' which has spontaneously transformed to an fcc martensite during thinning.	153
62	X-ray diffraction scans illustrating reversion of α'' to β during early stages of aging alloy 227 (7Mo-4Cr-2.5Al).	154
63	Transmission electron micrograph of alloy 227 solution treated and aged 6 minutes at 900F.	155
64	Selected area diffraction patterns from TEM samples in which α -phase has precipitated in a beta matrix.	156-157
65	Athermal omega phase in solution treated alloy 240 as revealed by TEM.	158
66	Transmission electron micrograph of solution treated alloy 243 showing primary α and Ti_5Si_3 particles.	159
67	Light micrograph of solution treated alloy 243 illustrating similarity in size of Ti_5Si_3 and primary α particles.	159

LIST OF ILLUSTRATIONS cont.

<u>Figure No.</u>	<u>Title</u>	<u>Page No.</u>
68	Ellipsoidal omega particles in alloy 240 solution treated and aged 8 hrs at 800F as revealed by transmission-electron microscopy.	160
69	Transmission electron micrograph of alloy 243 solution treated and aged 8 hrs at 950F showing α -phase precipitation in β matrix.	160
70	Transmission micrograph of alloy 266 as solution treated revealing sub-grain structure in β matrix.	161
71	Selected area electron diffraction pattern in alloy 266 indicating grain boundary α -phase precipitate has Burgers orientation relation with β matrix.	162
72	Alloy 266 solution treated and aged 2 minutes at 1000F.	163
73	Transmission electron micrographs of alloy 266 solution treated and aged at 1000F illustrating agglomeration of α -phase precipitates.	164
74	Simulation of Phase III forging using plasticine "swiss-rolls."	165
75	Tri-directional primary forging sequence used to convert ingots to 10.5 inch RCS bloom.	166
76	Schematic illustration of conversion of full sized 10.5 mil RCS bloom to 6 inch diameter billet and corresponding samples used to simulate this pro essing sequence.	167

LIST OF ILLUSTRATIONS

cont.

<u>Figure No.</u>	<u>Title</u>	<u>Page No.</u>
77	Alloy 334 - comparison of yield strength-toughness after the various TMT sequences defined in Tables XXXVIII and XLII.	168
78	Alloy 334 - comparison of yield strength-reduction of area after various TMT sequences defined in Tables XXXVIII and XLII.	169
79	Alloy 227 - comparison of yield strength-toughness after various TMT sequences defined in Tables XXXIX and XLIV.	170
80	Alloy 227 - comparison of yield strength-reduction of area after the various TMT sequences defined in Tables XXXIX and XLIV.	171
81	Alloy 253 - comparison of yield strength-toughness after various TMT sequences defined in Tables XL and XLIII.	172
82	Alloy 253 - comparison of yield strength-reduction of area after various TMT sequences defined in Tables XL and XLIII.	173
83	Photomicrographs at 6-3/4 inch RCS billet stage.	174
84	Microstructure of alloys 334 and 227 as forged from 10.5 inch RCS to 6-3/4 inch RCS and allowed to air cool.	175
85	Transverse yield strength - toughness (K_Q) alloy 334 after various thermomechanical treatments.	176
86	Transverse yield strength-ductility (RA) alloy 334 after various thermomechanical treatment.	177

LIST OF ILLUSTRATIONS cont.

<u>Figure No.</u>	<u>Title</u>	<u>Page No.</u>
87	Transverse yield strength-toughness (K_Q) alloy 227 after various thermomechanical treatments.	178
88	Transverse yield strength-ductility (RA) alloy 227 after various thermomechanical treatments.	179
89	Specimen location diagram indicating position of various types of samples in the full six inch diameter billet.	180
90a	Pole figure of alloy 334 plate, (110) beta planes.	181
90b	Pole figure of alloy 334 plate, (200) beta planes.	182
91a	Pole figure of alloy 334 billet, (110) beta planes.	183
91b	Pole figure of alloy 334 billet, (200) beta planes.	184
92a	Pole figure of alloy 227 billet, (110) beta planes.	185
92b	Pole figure of alloy 227 billet, (200) beta planes.	186
93a	Pole figure of alloy 334 billet, (110) beta planes.	187
93b	Pole figure of alloy 334 billet, (200) beta planes.	188

LIST OF ILLUSTRATIONS cont.

<u>Figure No.</u>	<u>Title</u>	<u>Page No.</u>
93c	Pole figure of alloy 334 billet, (211) beta planes.	189
94	Alloy 334 - solution treated 1300F-4 hr WQ, pre-aged 662F-70 hrs.	190
95	Alloy 334 - solution treated 1300F-4 hrs WQ, duplex aged 572-91 hrs + 932F-4 hrs.	191
96	Alloy 253, sample 3C3Y1. Solution treated 1275F-4 hrs WQ, single aged 950F-96 hrs.	192
97	Alloy 253, sample 3C3Z1. Solution treated 1275F-4 hrs WQ, duplex aged 750F-8 hr + 900F - 8 hrs.	192
98	Alloy 334, sample 4C1Y1. Solution treated 1350F-4 hr WQ, single aged 900F-96 hr.	193
99	Alloy 334, sample 4C1Y1. Solution treated 1350F-4 hr WQ, single aged 900F-96 hr.	194
100	Alloy 334, sample 4C1Z1. Solution treated 1350F-4 hr WQ, duplex aged 750F-8 hr + 925F-8 hr.	195
101	Alloy 253, sample 3C3Y1. Solution treated 1275F-4 hr WQ, single aged 950F-96 hr.	196
102	Alloy 253, sample 3C3Z1. Solution treated 1275F-4 hr WQ, duplex aged 750F-8 hr + 900F-8 hr.	197
103	Alloy 334, six inch billet slice. Samples 4ELR10 and 4ESR2.	198
104	Alloy 334, sample 4ELR10. Fracture surface, crack path.	199

LIST OF ILLUSTRATIONS cont.

<u>Figure No.</u>	<u>Title</u>	<u>Page No.</u>
105	Alloy 334, sample 4ELR10.	200
106	Alloy 334, sample 4ELR10. SEM of fracture surface.	201
107	Alloy 334, sample 4ESR2. Fracture surface.	202
108	Alloy 334, sample 4ESR2. SEM of fracture surface.	203
109	Alloy 334 surface replicas of 4ELR10, 4ESR2.	204
110	Alloy 227 six inch billet slice. Samples 7ELR11 and 7ESR3.	205
111	Alloy 227, sample 7ELR11. Fracture surface.	206
112	Alloy 227, sample 7ELR11.	207
113	Alloy 227, sample 7ELR11. SEM of fracture surface.	208
114	Alloy 227, sample 7ELR11, surface replica.	209
115	Alloy 227, sample 7ESR3. Fracture surface, crack path.	210
116	Alloy 227, sample 7ERS3. SEM of fracture surface.	211
117	Alloy 227, sample 7ESR3, surface replica.	212
118	Alloy 227, six inch billet slice. Samples 7ELR9 and 7ESR1.	213
119	Alloy 227, sample 7ELR9. Fracture surface.	214

LIST OF ILLUSTRATIONS

cont.

<u>Figure No.</u>	<u>Title</u>	<u>Page No.</u>
120	Alloy 227, sample 7ESR1. Fracture surface.	215
121	Alloy 227, surface replicas of 7ELR9, 7ESR1.	216
122	Alloy 253, six inch billet slice. Samples 3ELR10 and 3ESR2.	217
123	Alloy 253, sample 3ELR10. Fracture surface.	218
124	Alloy 253, sample 3ELR10.	219
125	Alloy 253, sample 3ELR10. SEM of fracture surface.	220
126	Alloy 253, sample 3ESR2. Fracture surface.	221
127	Alloy 253, sample 3ESR2. SEM of fracture surface.	222
128	Alloy 253, sample 3ESR2, surface replicas.	223
129	Alloy 334, six inch billet slice Sample 4MSL8.	224
130	Alloy 334, sample 4MSL8. Fracture surface, crack path.	225
131	Alloy 334, sample 4MSL8. Crack path.	226
132	Alloy 334, sample 4MSL8. SEM of fracture surface.	227
133	Alloy 334, sample 4MSL8. Surface replica.	228
134	Alloy 227 six inch slice. Sample 7MSL4.	229

LIST OF ILLUSTRATIONS

cont.

<u>Figure No.</u>	<u>Title</u>	<u>Page No.</u>
135	Alloy 227, sample 7MSL4. Crack path.	230
136	Alloy 227, sample 7MSL4. Fracture surface.	231
137	Alloy 227, sample 7MSL4. SEM of fracture surface.	232
138	Alloy 227, sample 7MSL4. Surface replica.	233
139	Alloy 334. 10.5 inch RCS slice. Sample 4SL2.	234
140	Alloy 334, sample 4SL2. Fracture surface, crack path.	235
141	Alloy 334, sample 4SL2. SEM of fracture surface.	236
142	Alloy 334, sample 4SL2. Surface replica.	237
143	Alloy 227, 10.5 inch RCS slice. Sample SL2.	238
144	Alloy 227, sample 7SL2. Fracture surface.	239
145	Alloy 227, sample 7SL2.	240
146	Alloy 227, sample 7SL2. SEM of fracture surface.	241
147	Alloy 227, sample 7SL2. Surface replica.	242
148	Alloy 334, six inch billet slice. Sample 4SR12.	243
149	Alloy 334, sample 4SR12. Fracture surface.	244

LIST OF ILLUSTRATIONS cont.

<u>Figure No.</u>	<u>Title</u>	<u>Page No.</u>
150	Alloy 334, sample 4SR12. Surface replica.	245
151	Alloy 227, six inch billet slice. Sample 7SR22.	246
152	Alloy 227, sample 7SR22. Fracture surface.	247
153	Alloy 227, sample 7SR22. Crack path.	248
154	Alloy 227, sample 7SR22. Surface replica.	249
155	Alloy 334, six inch billet. Sample 4SR16.	250
156	Alloy 334, sample 4SR16. Fracture surface.	251
157	Alloy 334, sample 4SR16. SEM of fracture surface.	252
158	Alloy 334, sample 4SR16. Surface replica.	253
159	Alloy 227, six inch billet slice. Sample 7SR20.	254
160	Alloy 227, sample 7SR20. Fracture surface.	255
161	Alloy 227, sample 7SR20. Crack path, surface replica.	256
162	Alloy 227, sample 7SR20. SEM of fracture surface.	257
163	Alloy 334, six inch billet full piece center samples. Samples 4SLC2 and 4LRC2.	258

LIST OF ILLUSTRATIONS

cont.

<u>Figure No.</u>	<u>Title</u>	<u>Page No.</u>
164	Alloy 334, sample 4SLC2. Fracture surface.	259
165	Alloy 334, sample 4SLC2. Crack path.	260
166	Alloy 334, sample 4SLC2. SEM of fracture surface.	261
167	Alloy 334, sample 4LRC2. Fracture surface, crack path.	262
168	Alloy 334, sample 4LRC2. SEM of fracture surface.	263
169	Alloy 334, sample 4LRC2. Surface replica.	264
170	Alloy 334, six inch billet full piece center sample 4SLC4.	265
171	Alloy 334, sample 4SLC4. SEM of fracture surface.	266
172	Alloy 334, sample 4SLC4. Surface replica.	267
173	Alloy 334, six inch billet full piece edge samples 4SLE2 and 4LRE2.	268
174	Alloy 334, sample 4SLE2. Fracture surface, crack path.	269
175	Alloy 334, sample 4LRE2. Fracture surface and replica.	270
176	Alloy 334, sample 4LRE2. Crack path.	271
177	Alloy 227, six inch billet full piece center samples 7SLC1 and 7LRC2.	272
178	Alloy 227, sample 7SLC1. Isometric and surface replica.	273

LIST OF ILLUSTRATIONS

cont.

<u>Figure No.</u>	<u>Title</u>	<u>Page No.</u>
179	Alloy 227, sample 7SLC1. Fracture surface.	273
180	Alloy 227, sample 7SLC1. Crack path.	274
181	Alloy 227, sample 7SLC1. SEM of fracture surface.	275
182	Alloy 227, sample 7LRC2. Fracture surface.	276
183	Alloy 227, sample 7LRC2. Crack path.	277
184	Alloy 227, sample 7LRC2. Crack path.	278
185	Alloy 227, sample 7LRC2. SEM of fracture surface.	279
186	Alloy 227, six inch billet full piece edge samples 7SLE2 and 7LRE2.	280
187	Alloy 227, sample 7SLE2. Fracture surface and surface replica.	281
188	Alloy 227, sample 7SLE2. Crack path.	282
189	Alloy 227, sample 7LRE2. Fracture surface and crack path.	283
190	Alloy 227, sample 7LRE2. Crack path.	284
191	Alloy 227, sample 7LRE2. Surface replica.	285
192	Alloy 253, six inch billet full piece center samples 3SLC2 and 3LRC1.	285
193	Alloy 253, sample 3SLC2. Fracture surface and crack path.	286

LIST OF ILLUSTRATIONS cont.

<u>Figure No.</u>	<u>Title</u>	<u>Page No.</u>
194	Alloy 253, sample 3SLC2. SEM of fracture surface.	287
195	Alloy 253, sample 3SLC2. Surface replica.	288
196	Alloy 253, sample 3LRC1. Fracture surface and crack path.	289
197	Alloy 253, sample 3LRC1. Crack path.	290
198	Alloy 253, sample 3LRC1. SEM of fracture surface.	291
199	Alloy 253, sample 3LRC1. Surface replica.	292
200	Alloy 253, six inch billet full piece edge samples 3SLE2 and 3LRE2.	293
201	Alloy 253, sample 3SLE2. Fracture surface and crack path.	294
202	Alloy 253, sample 3SLE2. Surface replica.	295
203	Alloy 253, sample 3LRE2. Fracture surface and crack path.	296
204	Alloy 253, sample 3LRE2. Surface replica.	297
205	Alloy 334, half inch plate. Sample 4WRH1.	298
206	Alloy 334, sample 4WRH1. Fracture surface, crack path.	299
207	Alloy 334, sample 4WRH1. Surface replica.	300

LIST OF ILLUSTRATIONS cont.

<u>Figure No.</u>	<u>Title</u>	<u>Page No.</u>
208	Alloy 227, half inch plate. Sample 7WRL2.	301
209	Alloy 227, sample 7WRL2. Fracture surface, crack path.	302
210	Alloy 227, sample 7WRL2. Surface replica.	303
211	Alloy 253, half inch plate. Sample 3WRL2.	304
212	Alloy 253, sample 3WRL2. Fracture surface, crack path.	305
213	Alloy 253, sample 3WRL2. Surface replica.	306
214	Alloy 334, six inch billet full piece center sample 4TC2.	307
215	Alloy 334, sample 4TC2. Sectioned tensile sample.	308
216	Alloy 227, six inch billet slice. Sample 7ET3.	309
217	Alloy 227, sample 7ET3. Sectioned tensile sample.	310
218	Alloy 227, six inch billet slice. Sample 7MT7.	311
219	Alloy 227, sample 4MT7. SEM of fracture surface.	312
220	Alloy 227, sample 4MT7. Sectioned tensile sample.	313

LIST OF ILLUSTRATIONS cont.

<u>Figure No.</u>	<u>Title</u>	<u>Page No.</u>
221	Alloy 227, sample 4MT7. Sectioned tensile sample.	314
222	Alloy 334, six inch billet full piece. Sample 4T4.	315
223	Alloy 334, sample 4T4. Crack path.	316
224	Alloy 334, sample 4T4. Crack path.	317
225	Alloy 227, six inch billet full piece. Sample 7T2.	318
226	Alloy 227, sample 7T2. Tangential surface just away from fractured surface.	319
227	Alloy 227, sample 7T2. Crack path, void group adjacent to larger alpha particles.	320
228	Effect of aging temperature on mechanical properties - alloy 334.	321
229	Comparison of elevated temperature transverse yield strength, center six inch section contract alloys with reported data from other deep hardenable alloys.	322
230	Fatigue behavior of alloy 334.	323
231	Fatigue behavior of alloy 227.	324
232	Fatigue behavior of alloy 253.	325
233	Larson-Miller creep curves at 0.2% plastic deformation for contract alloys and other titanium alloys at the 150-170 ksi YS level.	326

LIST OF ILLUSTRATIONS

cont.

<u>Figure No.</u>	<u>Title</u>	<u>Page No.</u>
234-237	Toughness (K_Q) - yield strength trend lines.	327-330
238-241	Reduction of area - yield strength trend lines.	331-334
242-244	Overall alloy characteristic toughness (K_Q) - yield strength trend lines.	335-337
245-247	Overall alloy characteristic ductility (RA) - yield strength trend lines.	338-340
248-250	Transverse alloy characteristic toughness (K_Q) - yield strength trend line for "optimum" heat treatment.	341-343
251-253	Transverse alloy characteristic reduction of area (RA) - yield strength trend line for "optimum" heat treatment.	344-346
254-256	Transverse alloy characteristic elongation - yield strength trend line for "optimum" heat treatment.	347-349
257	Relationship of K_{Ic} to K_Q under present contract and parallel investigations.	350
258	Schematic representation of void formation and associated plastically deformed zone as result of applied tensile stress.	351
259	Schematic representation of relationship of ductility directionality to lenticular voids formed in a billet during tensile stress.	352

LIST OF ILLUSTRATIONS

<u>Figure No.</u>	<u>Title</u>	<u>Page No.</u>
260	Schematic representation of relationship of ductility directionality to disc-like voids formed in plate during tensile stress.	353
261	Schematic representation of effect of coarse alpha shape on ductility and toughness.	354
262	Toughness-yield strength characteristic alloy trend lines for present contract alloys and experimental and semi-commercial deep hardenable alloys.	355
263	Reduction of area-yield strength characteristic alloy trend lines for present contract alloys and experimental and semi-commercial deep hardenable alloys.	356

TABLE I

Compositions Screened in Phase I

Ti-Mo(Zr)-Al(Sn)	Ti-Mo(V, Zr)-Al (Sn)	Ti-Mo(Cr, Mn, Nb)-Al(Sn)	Ti-Mo-V(Cr, Fe)-Al (Phase Splitting)	Ti-6-2-4-6 Type	Ti-Mo-Al-Si
11Mo-4Al	12V-2.5Al	7Mo-4Cr-2.5Al	** 8Mo-8V-2Fe-3Al	** 6Al-2Sn-4Zr-6Mo	9Mo-2.5Al-0.3 Si
9Mo-4Al	10V-2.5Al	5Mo-2Cr-2.5Al	10Mo-8V-2.5Al	4Al-2Sn-4Zr-6Mo	11Mo-1Al-0.5Si
11Mo-2.5Al	12V-1Al		4Mo-8V-6Cr-2.5Al	3Al-2Sn-4Zr-8Mo	* 11Mo-2.5Al-0.5Si
9Mo-2.5Al	13V-3Zr-2.5Al	7Mo-1Mn-2.5Al	12Mo-6V-1Al	* 6Al-2Sn-4Zr-2Mo-4Cr	
7Mo-2.5Al	9V-3Zr-2.5Al	5Mo-2Mn-2.5Al	*10Mo-4Cr-2.5Al	* 6Al-2Sn-4Zr-2Mo-4Cr-2V	
9Mo-1Al	11V-3Zr-1.5Al-3Sn	8Mo-3Cb-2.5Al	*13Mo-4Cr-2.5Al		
7Mo-1Al					
11Mo-1Al	6Mo-6V				
9Mo-7.5Sn	5Mo-5V-2.5Al	*10V-4Cr-2.5Al			
9Mo-3Sn	7Mo-5V-2.5Al	* 4Mo-6V-4Cr-2.5Al			
7Mo-3Sn	5Mo-5V-1Al	* 8Mo-2Cr-7.5Sn			
9Mo-1.5Al-3Sn	7Mo-3V-2.5Al	* 8Mo-2Cr-1.5Al-3Sn			
7Mo-1.5Al-3Sn	8Mo-4V-1Al				
8Mo-4Zr-2.5Al	6Mo-3V-4Zr-2.5Al				
8Mo-2Zr-2.5Al	6Mo-3V-4Zr-7.5Sn				
8Mo-4Zr-7.5Sn	5Mo-5V-1.5Al-3Sn				
8Mo-4Zr-3Sn	4Mo-5V-4Zr-1.5Al-3Sn				
8Mo-4Zr-1.5Al-3Sn					
6Mo-4Zr-1.5Al-3Sn					
* 13Mo-4Al					
* 13Mo-2.5Al					
* 11Mo-4Al-3Sn					

* Additional Phase I Alloys

** Control (Commercial) Alloys.

TABLE II

Alloying Materials
Used in Formulating Phase I Alloy Melts

<u>Material</u>	<u>Supplier</u>	<u>Purity (%)</u>	<u>Principal Impurities (%)</u>	
Titanium Sponge (Sodium Reduced)	Phillips Brothers	99.5+	0.09 0.02 0.01	O Fe C
Molybdenum Granules	General Electric Co.	99.5+	0.05	O
Zirconium Sponge (Reactor Grade)	Carborundum Metals Climax, Inc.	99.5+	0.11 0.09 0.02	O Fe C
Tin (1/8" dia. x 1/8" long pieces)	National Lead Co.	99.85		
Vanadium	Foots Mineral Co.	99.6+	0.09 0.04 0.10	O C Fe
Chromium (electrolytic)	Union Carbide Corp. Mining & Metals Div.	99.45	0.04 0.04	O C
Manganese (electrolytic)	Union Carbide Corp. Mining & Metals Div.	99.78	0.20 0.01	O Fe
Columbium (electrolytic)	General Electric Co.	99.9+	0.009 0.008	Fe Ta
Iron (electrolytic)	The Glidden Co. Metals Div.	99.90	0.04	O
Aluminum (Pig)	Kaiser Aluminum & Chemical Corp.	99.997		
Silicon	Union Carbide Corp. Mining & Metals Div.	98.94	0.55 0.09	Fe Al

TABLE IIIBETA TRANSUS AND FINAL ROLLING TEMPERATURE
FOR PHASE I ALLOYS

<u>Alloy¹ Button No.</u>	<u>Composition % (Ti Balance)</u>	<u>Beta Transus (°F)</u>	<u>Final² Rolling Temperature (°F)</u>
266	11Mo-4Al	1625	1525
264	9Mo-4Al	1675	1575
220	11Mo-2.5Al	1525	1425
225	9Mo-2.5Al	1600	1500
234	7Mo-2.5Al	1625	1525
250	9Mo-1Al	1550	1450
256	7Mo-1Al	1575	1475
215	9Mo-7.5Sn	1450	1350
239	9Mo-3Sn	1475	1375
228	7Mo-3Sn	1500	1400
261	9Mo-1.5Al-3Sn	1575	1475
217	7Mo-1.5Al-3Sn	1550	1350
223	8Mo-4Zr-2.5Al	1575	1475
248	8Mo-2Zr-2.5Al	1625	1525
230	8Mo-4Zr-7.5Sn	1400	1300
244	8Mo-4Zr-3Sn	1475	1375
214	8Mo-4Zr-1.5Al-3Sn	1525	1425
233	6Mo-4Zr-1.5Al-3Sn	1575	1475
226	12V-2.5Al	1450	1350
252	10V-2.5Al	1450	1350
237	12V-1Al	1375	1275
222	11V-3Zr-2.5Al	1425	1325
260	9V-3Zr-2.5Al	1450	1350
254	11V-3Zr-1.5Al-3Sn	1400	1300
246	5Mo-5V-2.5Al	1525	1425
218	7Mo-5V-2.5Al	1500	1400
257	5Mo-5V-1Al	1500	1400
229	6Mo-3V-4Zr-2.5Al	1525	1425
259	7Mo-3V-2.5Al	1575	1475
231	8Mo-4V-1Al	1425	1325
238	6Mo-3V-4Zr-7.5Sn	1350	1250
247	5Mo-5V-1.5Al-3Sn	1475	1375
219	4Mo-5V-4Zr-1.5Al-3Sn	1500	1400

¹ Alloys were arc melted in random fashion to eliminate systematic changes in composition.

² Temperature selected for final hot rolling from 0.130" to 0.040" thick.

TABLE III cont.

BETA TRANSUS AND FINAL ROLLING TEMPERATURE
FOR PHASE I ALLOYS

Alloy ¹ Button No.	Composition % (Ti Balance)	Beta Transus (°F)	Final ² Rolling Temperature (°F)
227	7Mo-4Cr-2.5Al	1500	1400
242	5Mo-2Cr-2.5Al	1575	1475
255	7Mo-1Mn-2.5Al	1625	1525
236	5Mo-2Mn-2.5Al	1600	1500
249	8Mo-3Cb-2.5Al	1625	1525
216	8Mo-8V-2Fe-3Al	1375	1275
253	10Mo-8V-2.5Al	1425	1325
232	4Mo-8V-6Cr-2.5Al	1325	1225
241	12Mo-6V-1Al	1350	1250
235	6Mo-4Zr-6Al-2Sn	1725	1625
245	6Mo-4Zr-4Al-2Sn	1675	1575
221	8Mo-4Zr-4Al-2Sn	1625	1525
258	11Mo-1Al	1500	1400
240	6Mo-6V	1350	1250
251	9Mo-2.5Al-0.3Si	1625	1525
243	11Mo-1Al-0.5Si	1500	1400
331	13Mo-4Al	1600	1500
332	13Mo-2.5Al	1540	1440
326	11Mo-4Al-3Sn	1615	1515
323	8Mo-2Cr-7.5Sn	1400	1300
324	8Mo-2Cr-1.5Al-3Sn	1500	1400
341	11Mo-2.5Al-0.5Si	1575	1475
336	10V-4Cr-2.5Al	1360	1260
337	4Mo-6V-4Cr-2.5Al	1410	1310
333	10Mo-4Cr-2.5Al	1470	1370
334	10Mo-6Cr-2.5Al	1420	1320
335	13Mo-4Cr-2.5Al	1425	1325
338	4Mo-4Cr-4Zr-6Al-2Sn	1660	1560
339	2Mo-4V-4Cr-4Zr-6Al-2Sn	1600	1500

¹Alloys were arc melted in random fashion to eliminate systematic changes in composition.

²Temperature selected for final hot rolling from 0.130" to 0.040" thick.

TABLE IV

SELECTION OF SOLUTION TREATMENT AND AGING CYCLES
FOR
PHASE I - TIME-TEMPERATURE-TRANSFORMATION STUDY

Alloy No.	Composition, w/o (Ti Balance)	Beta Transus, F	Solution Treatment Parameters			Transformation Parameters		
			Lowest Temp. for Martensite Primary α , F	ST for 30% Primary α , F	Selected Treatment Temp., F	Estimated Molybdenum Equivalent, %	Estimated Transformation Temp., F	TTT Nose Time (mins)
266	11Mo-4Al	1625	1625	1575	1575	13.6	1125	2
264	9Mo-4Al	1675	1650	1600	1600	10.6	1150	0.5
220	11Mo-2.5Al	1525	1500	1475	1475	14.5	1100	5
225	9Mo-2.5Al	1600	1575	1575	1575	11.5	1100	1
234	7Mo-2.5Al	1625	1600	1550	1525	8.6	1100	0.4
250	9Mo-1Al	1550	1500	1475	1475	12.4	1050	1
256	7Mo-1Al	1575	1500	1525	1525	8.1	1100	0.3
258	11Mo-1Al	1500	1500	1475	1475	15.4	1100	5
215	9Mo-7.5Sn	1450	1400	1375	1375	18.6	1100	10
239	9Mo-3Sn	1475	1475	1425	1425	15.2	1050	5
228	7Mo-3Sn	1500	1500	1475	1475	12.3	1100	1
261	9Mo-1.5Al-3Sn	1575	1550	1475	1475	14.13	1050	5
217	7Mo-1.5Al-3Sn	1550	1550	1475	1475	11.4	1100	0.5
223	8Mo-4Zr-2.5Al	1575	1550	1525	1525	11.1	1100	0.5
248	8Mo-2Zr-2.5Al	1625	1600	1525	1525	10.6	1100	0.5
230	8Mo-4Zr-7.5Sn	1400	None	1325	1325	18.2	1050	10
244	8Mo-4Zr-3Sn	1475	1475	1400	1400	14.8	1100	5
214	8Mo-4Zr-1.5Al-3Sn	1525	1500	1475	1475	13.9	1100	5
233	6Mo-4Zr-1.5Al-3Sn	1525	1550	1525	1575	11.0	1050	0.5
226	12V-2.5Al	1450	1450	1375	1375	9.8	1100	0.4
252	10V-2.5Al	1450	1450	1400	1375	7.9	1125	0.3
237	12V-1Al	1425	1400	1300	1275	13.5	1050	2
222	11V-3Zr-2Al	1450	1450	1350	1350	9.6	1100	0.4
260	9V-3Zr-2.5Al	1400	1450	1400	1375	7.7	1075	0.3
254	11V-3Zr-1.5Al-3Sn	1350	1350	1275	1275	12.4	1050	1
240	6Mo-6V	1350	1350	1300	1300	14.4	1050	5
246	5Mo-5V-2.5Al	1525	1475	1475	1475	10.4	1100	0.4
218	7Mo-5V-2.5Al	1500	1450	1400	1400	13.2	1100	2
257	5Mo-5V-1Al	1500	1450	1400	1400	11.3	1050	0.5
259	7Mo-3V-2.5Al	1575	1550	1475	1475	11.4	1100	0.5
231	8Mo-4V-1Al	1425	1400	1375	1375	14.8	1075	5

continued

TABLE IV (continued)

SELECTION OF SOLUTION TREATMENT AND AGING CYCLES
FOR
PHASE I - TIME-TEMPERATURE-TRANSFORMATION STUDY

Alloy No.	Compositior, w/o (Ti Balance)	Beta Transus, F	Solution Treatment Parameters				Transformation Parameters		
			Lowest Temp. ST for 30% for Martensite Primary α		Selected Solution Treatment		Estimated Molybdenum Equivalent %	Estimated Temp. F	Estimated Time (mins)
			F	F	Temp. F	Time (hours)			
229	6Mo-3V-4Zr-2.5Al	1525	1475	1450	1450	2	11.8	1100	0.5
238	6Mo-3V-4Zr-7.5Sn	1350	1375	1300	1300	4	18.1	1050	10
247	5Mo-5V-1.5Al-3Sn	1475	1450	1425	1425	4	13.2	1050	2
219	4Mo-5V-4Zr-1.5Al-3Sn	1500	1450	1400	1400	4	12.7	1100	2
227	7Mo-4Cr-2.5Al	1500	None	1450	1450	2	16.1	1100	5
242	5Mo-2Cr-2.5Al	1575	1575	1550	1525	2	9.5	1100	0.4
255	7Mo-1Mn-2.5Al	1625	1600	1525	1525	2	10.8	1100	0.5
236	5Mo-2Mn-2.5Al	1600	1600	1525	1525	2	9.9	1100	0.4
249	8Mo-3Cb-2.5Al	1625	1600	1550	1525	2	11.3	1100	0.5
253	10Mo-8V-2.5Al	1425	None	1350	1350	4	20.5	1025	15
232	4Mo-8V-6Cr-2.5Al	1325	None	1300	1300	4	23.1	1000	15
241	12Mo-6V-1Al	1350	None	1275	1275	4	22.5	1000	15
245	6Mo-4Zr-4Al-2Sn	1675	1675	1600	1600	1	8.8	1150	0.3
221	8Mo-4Zr-3Al-2Sn	1625	1600	1575	1575	1	11.7	1150	0.5
251	9Mo-2.5Al-0.5Si	1625	1600	1500	1500	2	11.5	1100	0.5
243	11Mo-1Al-0.5Si	1500	1500	1475	1475	2	15.4	1100	0.5
CONTRACT ALLOYS									
216	8Mo-8V-2Fe-3Al	1375	None	1325	1325	4	24.2	1000	15
235	6Al-2Sn-4Zr-6Mo	1725	1675	1675	1675	0.5	7.6	1200	0.3

TABLE V
Selection of Solution Treatment and Aging Cycles
for
Time-Temperature-Transformation Studies
Supplemental Alloys

Alloy No.	Composition, w/o (Ti Balance)	Beta Transus, F	SOLUTION TREATMENT PARAMETERS				TRANSFORMATION PARAMETERS			
			Lowest Temp. for Martensite F	S.T. for 30% Primary, F	Selected Treatment Temp F	Solution Time (Hours)	Estimated Molybdenum Equivalent %	Estimated TTT Nose Temp F	Time (Mins)	
323	8Mo-2Cr-7.5Sn	1400	None	1425	1375 1325	4 4	16.8	1060 1060	20 80	
324	8Mo-2Cr-1.5Al-3Sn	1500	None	1435	1475 1425	2 4	12.0	1080 1080	15 30	
326	11Mo-4Al-3Sn	1615	1600	1475	1585 1535	1 2	9.3	1220 1200	15 30	
331	13Mo-4Al	1600	1600	1475	1575 1525	1 2	9.0	1125 1115	10 30	
332	13Mo-2.5Al	1540	1500	1400	1515 1465	2 2	10.5	1100 1040	10 25	
333	10Mo-4Cr-2.5Al	1470	None	1390	1450 1400	2 4	13.9	1010 1010	30 45	
334	10Mo-7Cr-2.5Al	1420	None	1275	1400 1350	4 4	17.1	1020 970	45 60	
335	13Mo-4Cr-2.5Al	1425	None	1300	1400 1350	4 4	16.9	950 950	45 60	
336	10V-4Cr-2.5Al	1360	None	1290	1325 1275	4 4	11.9	900 950	15 30	
337	4Mo-6V-4Cr-2.5Al	1410	None	1325	1375 1325	4 4	12.7	1000 975	15 30	
338	6Al-2Sn-4Zr-4Mo-4Cr	1660	1660	1580	1625 1575	1 1	6.9	1350 1320	5 18	
339	6Al-2Sn-4Zr-2Mo-4V-4Cr	1600	1575	1500	1575 1525	1 2	8.1	1250 1250	10 24	
341	11Mo-2.5Al-0.5Si	1575	1575	1480	1550 1500	2 2	8.5	1150 1150	5 10	

TABLE VI

Electron Probe Partition Data for 9Mo-2½Al
Containing 30% Primary Alpha Phase

	<u>Mo</u>	<u>Al</u>
Wt. % in Beta Phase	13%	1.5%
Wt. % in Alpha Phase*	<1%	4.8%

* Based on mass balance equation after estimation of fraction of alpha phase (30%).

TABLE VII
CALCULATED VALUES FOR NOSE TEMPERATURE AND TIME
FOR THE ADDITIONAL PHASE I ALLOYS

Alloy No.	Composition, w/o Titanium Balance	Calculated Values*		
		Beta Transus (F)	Nose Temperature (F)	Nose Time (Sec)
331	13Mo-4Al	1600	1124	24
332	13Mo-2.5Al	1540	1043	23
326	11Mo-4Al-3Sn	1615	1217	17
323	8Mo-2Cr-7.5Sn	1400	1066	21
324	8Mo-2Cr-1.5Al-3Sn	1500	1082	17
341	11Mo-2.5Al-0.5Si	1575	1151	10
336	10V-4Cr-2.5Al	1360	952	28
337	4Mo-6V-4Cr-2.5Al	1410	974	31
333	10Mo-4Cr-2.5Al	1470	1011	37
334	10Mo-6Cr-2.5Al	1420	966	50
335	13Mo-4Cr-2.5Al	1425	954	50
338	4Mo-4Cr-4Zr-6Al-2Sn	1660	1319	18
339	2Mo-4V-4Cr-4Zr-6Al-2Sn	1600	1258	24

* Calculated using the multiple linear regression equations shown in Appendix C.

TABLE VIII
Transformation Characteristics of Initial Phase I Alloys

Alloy No.	Composition, % (Ti Balance)	Beta Transus, F		Solution Treatment		Experimental TTT		Estimated TTT	
		Temp F	Time, Hrs.	Temp F	Time (Secs)	Temp F	Time (Secs)	Temp F	Time (Secs)
266	11Mo-4Al	1625	1	1575	1	1150	13	1125	120
264	9Mo-4Al	1675	1	1600	1	1175	6	1150	30
220	11Mo-2.5Al	1525	2	1475	2	1050	7	1100	300
225	9Mo-2.5Al	1600	1	1575	1	1125	6	1100	60
234	7Mo-2.5Al	1625	2	1525	2	1150	6	1100	24
250	9Mo-1Al	1550	2	1475	2	875	6	1050	60
256	7Mo-1Al	1575	2	1525	2	1150	6	1100	18
258	11Mo-1Al	1500	2	1475	2	1100	7	1100	300
215	9Mo-7.5Sn	1450	4	1375	4	1025	12	1100	600
239	9Mo-3Sn	1475	4	1425	4	975	6	1050	300
228	7Mo-3Sn	1500	2	1475	2	1200	6	1100	60
261	9Mo-1.5Al-3Sn	1575	2	1475	2	975	7	1050	300
217	7Mo-1.5Al-3Sn	1550	2	1475	2	1150	6	1100	30
223	8Mo-4Zr-2.5Al	1575	2	1525	2	1175	6	1100	30
248	8Mo-2Zr-2.5Al	1625	2	1525	2	1150	6	1100	30
230	8Mo-4Zr-7.5Sn	1400	4	1325	4	1025	7	1050	600
244	8Mo-4Zr-3Sn	1475	4	1400	4	1050	6	1100	300
214	8Mo-4Zr-1.5Al-3Sn	1525	2	1475	2	1075	6	1100	300
233	6Mo-4Zr-1.5Al-3Sn	1525	2	1575	2	1200	6	1050	30
226	12V-2.5Al	1450	4	1375	4	1075	6	1100	24
252	10V-2.5Al	1450	4	1375	4	1075	6	1125	18
237	12V-1Al	1375	4	1275	4	800	6	1050	2
222	11V-3Zr-2Al	1425	4	1350	4	1075	6	1100	24
260	9V-3Zr-2.5Al	1450	4	1375	4	1025	6	1075	18
254	11V-3Zr-1.5Al-3Sn	1400	4	1275	4	925	6	1050	1

(Continued next page)

TABLE VIII
(continued)

Transformation Characteristics of Initial Phase I Alloys

Alloy No.	Composition, % (Ti Balance)	Beta Transus, F	Solution Treatment Temp F	Solution Treatment Time, Hrs.	Experimental III Temp F	Experimental III Time (Secs)	ΔT_N (°F)	Estimated III Temp F	Time (Secs)
240	6Mo-6V	1350	1300	4	875	9	475	1050	300
246	5Mo-5V-2.5Al	1525	1475	2	1100	6	425	1100	24
218	7Mo-5V-2.5Al	1500	1400	4	1025	6	475	1100	120
237	5Mo-5V-1Al	1500	1400	4	950	6	550	1050	30
259	7Mo-3V-2.5Al	1575	1475	2	1050	6	525	1100	30
231	8Mo-4V-1Al	1425	1375	4	925	6	500	1075	300
229	6Mo-3V-4Zr-2.5Al	1525	1450	2	1100	6	425	1100	30
238	6Mo-3V-4Zr-7.5Sn	1350	1300	4	950	13	400	1050	600
247	5Mo-5V-1.5Al-3Sn	1475	1425	4	1075	6	400	1050	120
219	4Mo-5V-4Zr-1.5Al-3Sn	1500	1400	4	1075	6	425	1100	120
227	7Mo-4Cr-2.5Al	1500	1450	2	1050	9	450	1100	300
242	5Mo-2Cr-2.5Al	1575	1525	2	1100	6	475	1100	24
255	7Mo-1Mn-2.5Al	1625	1525	2	1075	6	550	1100	30
236	5Mo-2Mn-2.5Al	1600	1525	2	1050	6	550	1100	24
249	8Mo-3Cb-2.5Al	1625	1525	2	1125	6	500	1100	30
253	10Mo-8V-2.5Al	1425	1350	4	975	32	450	1025	900
232	4Mo-8V-6Co-2.5Al	1325	1300	4	900	60	425	1000	900
241	12Mo-6V-1Al	1350	1275	4	875	60	475	1000	900
245	6Mo-4Zr-4Al-2Sn	1675	1600	1	1200	6	475	1150	18
221	8Mo-4Zr-3Al-2Sn	1625	1575	1	1300	6	325	1150	30
251	9Mo-2.5Al-0.5Si	1625	1500	2	1150	6	475	1100	30
243	11Mo-1Al-0.5Si	1500	1475	2	1050	8	450	1100	300
216	8Mo-8V-2Fe-3Al	1375	1325	4	875	150	500	1000	900
235	6Al-2Sn-4Zr-6Mo	1725	1675	0.5	1175	6	550	1200	18

* $\Delta T = B_{Cr} - T_N$, B_{Cr} is beta transus, T_N is nose temperature.

TABLE IX

Transformation Characteristics of the Additional Phase I Alloys

Alloy No.	Composition, W/O (Ti Balance)	Beta Transus, F	Solution Treatment Temp F	Solution Treatment Time, Hrs.	Experimental TTT Temp F	Experimental TTT Time (Secs)	ΔT^* (°F)	Calculated TTT Temp F	Nose Time (Secs)
323	8Mo-2Cr-7.5Sn	1400	1375 1325	4 4	1025 1025	66 360	425 425	1066	21
324	8Mo-2Cr-1.5Al-3Sn	1500	1475 1425	2 4	1050 1050	18 28	450 450	1082	17
326	11Mo-4Al-3Sn	1575	1585 1535	1 2	1200 1175	21 32	415 440	1217	17
331	13Mo-4Al	1550	1575 1525	1 2	1175 1100	8 24	425 500	1124	24
332	13Mo-2.5Al	1500	1515 1465	2 2	1150 1025	21 26	400 525	1043	23
333	10Mo-4Cr-2.5Al	1450	1450 1400	2 4	975 975	120 190	500 500	1011	37
334	10Mo-6Cr-2.5Al	1375	1400 1350	4 4	1025 950	165 360	395 470	966	50
335	13Mo-4Cr-2.5Al	1430	1400 1350	4 4	925 1000	225 360	505 430	954	50
336	10 V-4Cr-2.5Al	1375	1325 1275	4 4	825 850	15 24	535 510	952	28
337	4Mo-6V-4Cr-2.5Al	1410	1375 1325	4 4	1025 975	34 190	385 435	974	31
338	4Mo-4Cr-4Zr-6Al-2Sn	1675	1625 1575	1 1	1200 1200	7 17	460 460	1319	18
339	2Mo-4V-4Cr-4Zr-6Al-2Sn	1525	1575 1525	1 2	1150 1150	94 130	450 450	1258	24
341	11Mo-2.5Al-0.5Si	1550	1550 1500	2 2	1200 1200	9 12	375 375	1151	10

* $\Delta T = B_{tr} - T_n$, where B_{tr} is beta transus and T_n is nose temperature.

TABLE I
ACID STRENGTH AND HARDNESS POTENTIAL FOR THE INITIAL PHASE I ALLOYS

Alloy No.	Composition w/o (% Balance)	Beta Transus (°F)	Heat Treatment		Tensile Properties				Yield Strength		Elongation		Area Reduction		Fracture		Est. Time for Heat Treatment (Hrs)	Est. Time for Heat Treatment (Hrs)	F-T-F Temp. (°F)	ASTM Spec.		
			Solution Temp. (°F)	Aging Temp. (°F)	Ultimate Tensile Strength (ksi)	Yield Strength 0.2% Offset (ksi)	0.2% Offset in 0.5" Area (%)	4.0" Area (%)	8.0" Area (%)	16.0" Area (%)	0.2% Offset (ksi)	0.2% Offset in 0.5" Area (%)	4.0" Area (%)	8.0" Area (%)	Fracture Temp. (°F)	Fracture Temp. (°F)						
266	1180-4A1	1625	1575	1	1000	---	---	---	---	---	---	---	---	---	---	---	---	---	---	---	---	
267	880-4A1	1675	1600	1	1050	---	---	---	---	---	---	---	---	---	---	---	---	---	---	---	---	
220	1180-2 SA1	1525	1475	2	950	204.2	---	3.0	3.3	16.6	---	---	---	---	---	---	---	---	---	---	---	
225	880-4A1	1600	1575	1	1000	---	---	---	---	---	---	---	---	---	---	---	---	---	---	---	---	
226	880-2 SA1	1650	1600	1	1000	---	---	---	---	---	---	---	---	---	---	---	---	---	---	---	---	
234	880-2 SA1	1625	1525	2	1000	185.5	183.1	3.8	4.4	15.9	---	---	---	---	---	---	---	---	---	---	---	
258	880-1A1	1575	1475	2	950	186.3	183.1	4.0	4.6	16.2	---	---	---	---	---	---	---	---	---	---	---	
258	880-1A1	1575	1475	2	1000	186.3	183.1	3.5	4.3	15.5	---	---	---	---	---	---	---	---	---	---	---	
213	880-7 SA1	1650	1475	2	950	170.4	167.2	4.0	4.6	15.8	---	---	---	---	---	---	---	---	---	---	---	
213	880-7 SA1	1650	1475	2	1000	170.4	167.2	4.0	4.6	15.8	---	---	---	---	---	---	---	---	---	---	---	
218	880-3 SA1	1600	1475	2	950	186.3	183.1	4.0	4.6	15.8	---	---	---	---	---	---	---	---	---	---	---	
218	880-3 SA1	1600	1475	2	1000	186.3	183.1	4.0	4.6	15.8	---	---	---	---	---	---	---	---	---	---	---	
217	880-1 SA1-35n	1575	1475	2	950	201.5	193.3	2.0	2.0	15.3	---	---	---	---	---	---	---	---	---	---	---	
217	880-1 SA1-35n	1575	1475	2	1000	201.5	193.3	2.0	2.0	15.3	---	---	---	---	---	---	---	---	---	---	---	
248	880-42R-2 SA1	1625	1525	2	1000	186.7	175.7	1.8	6.4	16.0	---	---	---	---	---	---	---	---	---	---	---	
230	880-42R-2 SA1	1400	1325	4	900	139.8	130.8	4.0	11.9	16.1	---	---	---	---	---	---	---	---	---	---	---	
244	880-42R-7 SA1	1400	1400	6	900	137.3	130.8	4.0	19.8	16.4	---	---	---	---	---	---	---	---	---	---	---	
214	880-42R-1 SA1-35n	1525	1475	2	950	---	---	---	---	---	---	---	---	---	---	---	---	---	---	---	---	
214	880-42R-1 SA1-35n	1525	1475	2	950	---	---	---	---	---	---	---	---	---	---	---	---	---	---	---	---	---
235	1180-2 SA1	1450	1375	4	950	155.4	148.6	8.0	24.4	15.5	---	---	---	---	---	---	---	---	---	---	---	
235	1180-2 SA1	1450	1375	4	950	155.4	148.6	13.0	38.2	15.2	---	---	---	---	---	---	---	---	---	---	---	
237	1180-2 SA1	1375	1350	4	900	139.8	133.3	4.7	12.0	13.8	---	---	---	---	---	---	---	---	---	---	---	
222	1180-2 SA1	1425	1350	4	950	142.2	143.1	9.0	27.0	16.5	---	---	---	---	---	---	---	---	---	---	---	
240	880-42R-2 SA1	1400	1375	4	900	154.7	147.3	4.5	6.0	14.2	---	---	---	---	---	---	---	---	---	---	---	
254	1180-32R-1 SA1-35n	1400	1275	4	850	154.7	147.3	4.0	18.6	13.2	---	---	---	---	---	---	---	---	---	---	---	
240	880-42R	1350	1300	4	800	190.9	188.5	4.0	3.6	16.1	---	---	---	---	---	---	---	---	---	---	---	
246	880-32R-2 SA1	1525	1475	2	950	182.7	177.1	4.0	8.5	16.2	---	---	---	---	---	---	---	---	---	---	---	
218	880-32R-2 SA1	1500	1400	4	800	177.4	161.4	4.0	6.5	16.6	---	---	---	---	---	---	---	---	---	---	---	
257	880-32R-1 SA1	1500	1400	4	800	169.3	152.9	2.0	3.8	16.4	---	---	---	---	---	---	---	---	---	---	---	
259	880-32R-2 SA1	1575	1475	2	950	188.6	167.4	4.0	6.2	16.4	---	---	---	---	---	---	---	---	---	---	---	
231	880-42R-1 SA1	1425	1375	4	800	176.4	174.5	3.5	7.2	16.1	---	---	---	---	---	---	---	---	---	---	---	
229	880-32R-2 SA1	1525	1475	2	950	182.8	170.3	4.0	10.5	16.2	---	---	---	---	---	---	---	---	---	---	---	
238	880-32R-42R-7 SA1	1350	1300	4	850	179.5	168.0	4.0	5.2	16.2	---	---	---	---	---	---	---	---	---	---	---	
247	880-32R-1 SA1-35n	1475	1425	4	950	173.8	163.8	4.0	17.5	15.0	---	---	---	---	---	---	---	---	---	---	---	
219	880-32R-1 SA1-35n	1500	1400	4	950	170.9	159.7	8.0	11.4	14.6	---	---	---	---	---	---	---	---	---	---	---	
227	880-42R-2 SA1	1500	1450	2	900	222.9	211.0	3.0	3.3	15.4	---	---	---	---	---	---	---	---	---	---	---	
242	880-22R-2 SA1	1575	1525	2	950	182.1	182.0	4.0	10.7	15.6	---	---	---	---	---	---	---	---	---	---	---	
255	880-180R-2 SA1	1625	1525	2	950	---	---	---	---	---	---	---	---	---	---	---	---	---	---	---	---	---
236	880-280R-2 SA1	1600	1525	2	950	179.8	178.9	4.0	7.0	17.4	---	---	---	---	---	---	---	---	---	---	---	
249	880-302R-2 SA1	1625	1525	2	950	---	---	---	---	---	---	---	---	---	---	---	---	---	---	---	---	---
216	880-42R-32R-3A1	1375	1325	4	850	206.3	194.9	3.5	5.6	18.5	---	---	---	---	---	---	---	---	---	---	---	
216	1180-42R-32R-3A1	1325	1300	4	850	182.3	179.6	2.0	6.5	14.3	---	---	---	---	---	---	---	---	---	---	---	
232	880-42R-42R-2 SA1	1300	1275	4	800	170.3	163.8	4.0	7.6	15.3	---	---	---	---	---	---	---	---	---	---	---	
241	1180-42R-42R-2 SA1	1350	1275	4	800	175.9	159.7	4.0	8.9	13.5	---	---	---	---	---	---	---	---	---	---	---	
235	880-42R-4A1-25n	1725	1675	0.5	1100	---	---	---	---	---	---	---	---	---	---	---	---	---	---	---	---	---
245	880-42R-4A1-25n	1675	1600	1	1050	---	---	---	---	---	---	---	---	---	---	---	---	---	---	---	---	---
221	880-42R-3A1-25n	1625	1575	1	1050	---	---	---	---	---	---	---	---	---	---	---	---	---	---	---	---	---
251	880-2 SA1-0.35I	1625	1500	2	1000	183.0	179.6	3.0	9.1	15.3	---	---	---	---	---	---	---	---	---	---	---	
243	1180-1A1-0.35I	1500	1475	2	950	215.2	199.4	4.0	3.7	16.5	---	---	---	---	---	---	---	---	---	---	---	---

*Failed in grip because of high notch sensitivity.

† Where ΔT = (P_{Tr} - T_W), P_{Tr} is beta transus temperature and T_W is nose temperature.

‡ Control (commercial alloys)

TABLE XI

SUMMARY OF AGED HARDNESS FOR THE ADDITIONAL PHASE I ALLOYS

Alloy No.	Composition w/o (Ti Balance)	Beta Transus (°F)	Heat Treatment			8 Hour At Temp. (VPN)	Hardness		Est. Time for Max. Hardness (hrs.)
			Solution Temp. (°F)	Time (hr)	Aging-Temp. (°F) (8 hr @ Temp.)		Est. Max. Hardness At Same Temp. (VPN)	Est. Max. Hardness (hrs.)	
323	8Mo-2Cr-7.5Sn	1400	1375	4	950	333	340	~100	
324	8Mo-2Cr-1.5Al-3Sn	1500	1325	4	950	351	360	~100	
			1475	2	950	383	390	20	
326	11Mo-4Al-3Sn	1575	1425	4	950	370	390	2	
			1585	1	1050	383	397	~ 50	
331	13Mo-4Al	1550	1535	2	1050	397	410	2	
			1575	1	975	387	392	~ 25	
332	13Mo-2.5Al	1500	1525	2	975	417	435	2.5	
			1515	2	950	373	388	~ 25	
333	10Mo-4Cr-2.5Al	1450	1465	2	950	397	411	3.5	
			1450	2	900	383	387	~ 50	
334	10Mo-6Cr-2.5Al	1375	1400	4	900	401	405	5	
			1400	4	850	264	405	~250	
335	13Mo-4Cr-2.5Al	1430	1350	4	850	289	410	~250	
			1400	4	850	319	385	~100	
336	10V-4Cr-2.5Al	1375	1350	4	850	366	404	~ 50	
			1325	4	850	390	396	~ 50	
337	4Mo-6V-4Cr-2.5Al	1410	1275	4	850	360	375	6	
			1375	4	875	421	430	5	
338	4Mo-4Cr-4Zr-6Al-2Sn	1675	1325	4	875	360	385	~ 50	
			1625	1	1050	464	466	4	
339	2Mo-4V-4Cr-4Zr-6Al-2Sn	1525	1575	1	1050	464	479	1	
			1575	1	1050	421	424	6	
341	11Mo-2.5Al-0.5Si	1550	1525	2	1050	429	429	8	
			1550	2	950	425	446	2.5	
			1500	2	950	421	430	2	

TABLE XII

**EFFECT OF COOLING FROM THE ANNEALING TEMPERATURE
AT A RATE DESIGNED TO SIMULATE THAT AT THE CENTER
OF A 6" DIAMETER SECTION ON SUBSEQUENT ATTAINABLE STRENGTH**

Alloy No.	Composition	Beta Transus (°F)	T-T-T Characteristics		Heat Treatment		Cooling Technique	Hardness (VPN)	Loss in Attainable Strength After SC (VPN)
			Nose Temp. (°F)	Nose Time (Secs)	Solution Treatment Temp. (°F)	Aging Temp. (°F)			
9-2.5 5 lb. melt	9Mo-2.5Al	1600	1125	6	2	-	WQ	235	49
					"	8	WQ	394	
					"	-	SC ^a	281	
					"	8	SC ^a	345	
215	9Mo-7.5Sn	1450	1025	12	4	-	WQ	236	26
					"	8	WQ ^b	376	
					"	-	SC ^b	262	
					"	8	SC ^b	350	
232	4Mo-8V-6Cr-2.5Al	1325	900	60	4	-	WQ	264	3
					"	8	WQ	404	
					"	-	SC ^c	266	
					"	8	SC ^c	401	

SC^a Simulated cool: 1500F-1300F in 1.9 minutes, 1300F-1100F in further 0.8 minutes, 1100F-900F in further 0.8 minutes and final air cool.

SC^b Simulated cool: 1375F-1175F in 1.9 minutes, 1175F-975F in further 0.9 minutes, 975F-775F in further 1 minute and final air cool.

SC^c Simulated cool: 1300F-1100F in 2.0 minutes, 1100F-900F in further 0.9 minutes, 900F-700F in further 1.1 minutes and final air cool.

TABLE XIII

Alloys Selected for Phase II Evaluation

<u>Alloy No.</u>	<u>Composition, W/O Titanium Balance</u>	<u>Beta Transus (F)</u>	<u>Density (lbs/m³)</u>	<u>Estimated U.T.S. at Center of Six-Inch Section/Density (Inches)</u>
232	4Mo-8V-6Co-2.5Al	1325	0.171	1.18
334	10Mo-6Cr-2.5Al	1420	0.171	1.14
253	10Mo-8V-2.5Al	1425	0.173	1.12
337	4Mo-6V-4Cr-2.5Al	1410	0.168	1.19
227	7Mo-4Cr-2.5Al	1500	0.169	1.22
243	11Mo-1Al-0.5Si	1500	0.172	1.15
261	9Mo-1.5Al-3Sn	1575	0.172	1.11
266	11Mo-4Al	1625	0.169	1.21
339	6Al-2Sn-4Zr-2Mo-4Cr-4V	1600	0.162	1.23
338	6Al-2Sn-4Zr-4Mo-4Cr	1660	0.163	1.22

TABLE XIV
PHASE II
MATERIALS USED IN INGOT FORMULATIONS

<u>Material</u>	<u>Purity, %</u>	<u>Principal Impurities, %</u>			
		<u>O</u>	<u>N</u>	<u>Fe</u>	<u>C</u>
Titanium Sponge, ICI	99.5+	0.09	0.01	-	-
Molybdenum Granules	99.5+	0.05	-	-	-
Zirconium Sponge (Reactor grade)	99.5+	0.11	-	0.09	0.02
Tin, 1/8" dia. x 1/8"	99.85	-	-	-	-
Vanadium/Aluminum Master (85-15)	-	0.210	-	0.4	-
Vanadium	99.6+	0.09	-	0.10	0.04
Chromium (Electrolytic)	99.45	0.04	-	-	0.04
Aluminum	99.997	-	-	-	-
Silicon	98.94	-	-	0.55	-

TABLE XV

PROTECTIVE COATING DETAILS

Forging

<u>Temperature</u>	<u>Metlseel Coating</u>	<u>Thickness</u>
1500-1750F	RA-537	5 - 10 inches
1800-2300F	RA-538	10-20 inches

Hot Rolling

<u>Temperature</u>	<u>Metlseel Coating</u>	<u>Thickness</u>
1200-1700F	RA-536	2 - 4 inches
1500-2100F	RA-537	5 - 10 inches

Supplier: Pemco Products
Glidden-Durkee Division
5601 Eastern Avenue
Baltimore, Md.

TABLE XVI
TEMPERATURES FOR PHASE II FORGING AND ROLLING

Phase II Ingot No.	Alloy Composition	Forging Temperature, F		Hot Rolling Temperature, F
		Initial	Reheats	
149	4Mo-8V-6Cr-2.5Al	1750	1750, 1600, 1500	1500
177	10Mo-6Cr-2.5Al	1750	1750, 1600, 1500	1500
170	10Mo-8V-2.5Al	1750	1750, 1600, 1500	1500
174	4Mo-6V-4Cr-2.5Al	1750	1750, 1600, 1500	1500
169	7Mo-4Cr-2.5Al	1750	1750, 1600, 1500	1575
171	11Mo-1Al-0.5Si	1750	1750, 1600, 1500	1575
168	9Mo-1.5Al-3Sn	1750	1750, 1600, 1500	1575
167	11Mo-4Al	1750	1750, 1600, 1500	1650
176	2Mo-4V-4Cr-4Zr-6Al-2Sn	1850	1850, 1750, 1650	1750
175	4Mo-4Cr-4Zr-6Al-2Sn	1850	1850, 1750, 1650	1800

TABLE XVII

HEAT TREATMENT CYCLES FOR PHASE II ALLOYS

Simulated Cooling at Center - Six Inch Diameter

<u>Alloy No.</u>	<u>Phase II Ingot No.</u>	<u>Composition</u>	<u>Solution Treatment</u>	<u>Simulated Cooling Cycle</u>		<u>Age Cycle</u>	
232	149	4Mo-8V-6Cr-2.5Al	1300F-4 hrs	1100F-118 secs,	900F-58 secs,	700F-62 secs, air cool	850F-8 hrs
334	177	10Mo-6Cr-2.5Al	1325F-4 hrs	1125F-119 secs,	925F-55 secs,	725F-62 secs, air cool	875F-96 hrs
253	170	10Mo-8V-2.5Al	1325F-4 hrs	1125F-119 secs,	925F-55 secs,	725F-62 secs, air cool	900F-96 hrs
337	174	4Mo-6V-4Cr-2.5Al	1350F-4 hrs	1150F-118 secs,	950F-53 secs,	750F-61 Secs, air cool	875F-24 hrs
227	169	7Mo-4Cr-2.5Al	1425F-4 hrs	1225F-116 secs,	1025F-50 secs,	825F-55 secs, air cool	900F-8 hrs
243	171	11Mo-1Al-0.5Si	1450F-2 hrs	1250F-116 secs,	1050F-49 secs,	850F-53 secs, air cool	1000F-4 hrs
261	168	9Mo-1.5Al-3Sn	1475F-2 hrs	1275F-114 secs,	1075F-48 secs,	875F-51 secs, air cool	900F-4 hrs
266	167	11Mo-4Al	1515F-1 hr	1375F-112 secs,	1175F-43 secs,	975F-43 secs, air cool	1000F-8 hrs
339	176	2Mo-4V-4Cr-4Zr-6Al-2Sn	1475F-2 hrs	1275F-114 secs,	1075F-48 secs,	875F-51 secs, air cool	1050F-24 hrs
338	175	4Mo-4Cr-4Zr-6Al-2Sn	1550F-2 hrs	1350F-112 secs,	1150F-43 secs,	950F-46 secs, air cool	1050F-4 hrs
<u>Control Alloys</u>							
216	172	8Mo-8V-2Fe-3Al	1300F-4 hrs	1100F-118 secs,	900F-58 secs,	700F-62 secs, air cool	900F-96 hrs
235	178	6Al-2Sn-4Zr-6Mo	1515-6 hrs	1315F-112 secs,	1175F-43 secs,	975F-43 secs, air cool	1100F-8 hrs

TABLE XVIII

SOLUTION TREATMENT AND AGING CYCLES FOR PHASE II ALLOYS

<u>Alloy No.</u>	<u>Phase II Ingot No.</u>	<u>Composition</u>	<u>Beta Trans. OF</u>	<u>Solution Temp. Range</u>	<u>Aging Treatment Range</u>
232	149	4Mo-8V-6Cr-2.5Al	1325	1250-1350F	850 - 1000 F 8 hrs.
334	177	10Mo-6Cr-2.5Al	1375	1275-1325F	875 - 975 F 96 hrs.
253	170	10Mo-8V-2.5Al	1425	1300-1450F	850 - 1100 F 4-96 hrs.
337	174	4Mo-6V-4Cr-2.5Al	1410	1250-1350F	875 - 975 F 24 hrs.
227	169	7Mo-4Cr-2.5Al	1500	1400-1475F	900 - 1100 F 8 hrs.
243	171	11Mo-1Al-0.5Si	1500	1425-1475F	950 - 1000 F 4-8 hrs.
261	168	9Mo-1.5Al-3Sn	1575	1450-1475F	850 - 900 F 4-8 hrs.
266	167	11Mo-4Al	1625	1500-1575F	1000 - 1050 F 8 hrs.
339	176	2Mo-4V-4Cr-4Zr-6Al-2Sn	1525	1325-1475F	1050 F - 24 hrs.
338	175	4Mo-4Cr-4Zr-6Al-2Sn	1675	1500-1550F	1050 - 1250 F 4 hrs.

TABLE XIX
PHASE II EVALUATION PROGRAM

<u>Alloy No.</u>	<u>Phase II Ingot No.</u>	<u>Composition</u>	<u>Mechanical Property Study</u>	<u>Dynamic Modulus</u>	<u>Chem. Comp.</u>	<u>Density</u>	<u>Structural Characterization</u>	<u>Fine Structure Study</u>	<u>Fracture Crack Path Investigation</u>
232	149	4Mo-8V-6Cr-2.5Al	X	X	X	X	-	X	-
334	177	10Mo-6Cr-2.5Al	X	-	X	-	X	-	X
253	170	10Mo-8V-2.5Al	X	X	X	X	-	X	-
337	174	4Mo-6V-4Cr-2.5Al	X	-	X	-	X	-	-
227	169	7Mo-4Cr-2.5Al	X	X	X	X	X	X	X
243	171	11Mo-1Al-0.5Si	X	-	X	-	-	X	-
261	168	9Mo-1.5Al-3Sn	X	X	X	X	X	X	-
266	167	11Mo-4Al	X	X	X	X	-	X	-
339	176	2Mo-4V-4Cr-4Zr-6Al-2Sn	X	-	X	-	-	-	-
338	175	4Mo-4Cr-4Zr-6Al-2Sn	X	-	X	-	-	-	-
<u>Control Alloys</u>									
216	172	8Mo-8V-2Fe-3Al	X	-	X	X	X	-	X
235	178	6Al-2Sn-4Zr-6Mo	X	-	X	-	X	-	X

TABLE XX

PHASE II AGED MECHANICAL PROPERTY DATA
WATER QUENCHED VS. SIMULATED COOLED CONDITIONS

Phase I No.	Phase II No.	Phase II Composition (wt. %)	Density (lb./in. ³)	Solution Treatment (F°)	Cooling Patch	Hardness As Cooled (VHN)	Aging Treatment (F°)	Speci. Dir.	Aged Tensile Properties			Aged Hardness (VHN)	Fracture Toughness (ksi/in.)
									Ultimate Tensile Strength (ksi)	Elong. in 4D (%)	Redn. (%)		
266	167	1186-AA1	0.169	1575-1 hr	WQ	248	1000-8 hr	T	208.6	3.0	4.0	404	26,27.6,25.5
					SC	301		L	193.8	<1.0	4.2	379	44.3
					WQ	289		L	170.5	181.6	3.0	401	28.9,31.3
261	168	860-1.5A1-35a	0.172	1475-2 hr	WQ	236	900-4 hr	T	192.4	1.0	5.2	378	43.2,44.5
					SC	292		L	169.4	156.5	2.0	412	18.2
					WQ	256		L	200.8	200.8	---	390	14.3
232	149	446-8V-6Cr-2.5Al	0.171	1350-4 hr 1300-4 hr	WQ	272	850-8 hr	T	207.7	3.0	6.8	390	36.2,28.1
					SC	264		L	203.4	197.1	3.0	393	30.0
					WQ	278		L	208.8	200.8	<1.0	393	33.0,28.6,25.9
253	170	1086-8V-2.5Al	0.171	1450-2 hr 1325-4 hr	WQ	283		L	212.4	3.0	8.6	366	31.1
					SC	278		L	193.6	185.1	2.0	383	16.3
					WQ	256		L	196.7	186.2	4.0	372	47.0,41.2,39.4
243	171	1186-1A1-0.5S1	0.172	1475-2 hr	WQ	226	950	T	199.8	3.0	9.4	376	40.1,41.7
					SC	314	1000-4 hr	L	188.0	182.3	1.0	353	23.2,24.5
					WQ	274		L	173.2	177.1	2.0	366	36.6
227	169	786-4Cr-2.5Al	0.169	1425-4 hr	WQ	268	900-8 hr	T	210.8	2.0	7.9	397	36.3,41.5
					SC	274		L	196.8	186.0	<1.0	401	76.3,39.8
					WQ	272		L	185.2	166.9	1.0	379	40.5,39.1
216	172	860-8V-2Fe-3Al	0.172	1300-4 hr	WQ	278	900-96 hr	T	196.0	2.0	6.8	390	29.7,34.8
					SC	280		L	184.0	165.6	4.0	386	35.5,34.3
					WQ	283		L	208.4	201.5	4.0	363	87.5 (short trans. fibrous)

a - Not investigated in Phase II.
 * - Premature failure.
 † - Low fracture toughness, broke during pre-cracking.
 @ - Tensile properties not determined.
 M.D. - Not determined.

TABLE XX (Cont'd)

PHASE II AGED MECHANICAL PROPERTY DATA
WATER QUENCHED VS. SIMULATED COOLED CONDITIONS

Phase I No.	Phase II Composition (bal. Ti)	Density (lbs/in ³)	Solution Treatment (F°)	Cooling Path	Hardness As Cooled (VFN)	Aging Treatment (F°)	Speci. Dir.	Aged Tensile Properties*			Elong. in 4D (B)	Elong. in 8D (C)	Area (C)	Yield Strength 0.2% Offset (ksi)	Tensile Strength (ksi)	Ultrasonic	Break	Aged Hardness (VFN)	Fracture Toughness (ksi/in ^{3/2})
								Strength 0.2% Offset (ksi)	Tensile Strength (ksi)	Ultrasonic									
334	177	10Mo-6Cr-2.5Al	1325-4 hr	WQ	272	875-96 hr	T	213.6	206.8	206.8	<1.0	4.0	16.7	15.7	15.7	4.0	408	34.1, 31.5	
				SC	264		L	196.8	194.0	194.0	1.0	8.2	15.7	15.7	15.7	8.2	386	55.1	
				WQ	272		T	188.3	185.9	185.9	1.0	4.4	15.0	15.0	15.0	4.4		41.5, 42.3	
				SC	266		L	204.1	197.2	197.2	<1.0	2.8	15.1	15.1	15.1	2.8		69.9	
				WQ	272		L	189.1	184.2	184.2	2.0	7.4	15.4	15.4	15.4	7.4		M.D.	
				SC	266		T	176.9	168.3	168.3	3.0	7.0	16.0	16.0	16.0	7.0		M.D.	
				WQ	274		T	178.1	170.7	170.7	1.0	9.0	13.8	13.8	13.8	9.0		M.D.	
				SC	278		L	212.2	207.1	207.1	1.0	6.6	15.5	15.5	15.5	6.6		M.D.	
				WQ	274		L	151.2	149.2	149.2	2.0	15.0	15.7	15.7	15.7	15.0		37.6, 28.3	
				SC	278		T	201.6	199.2	199.2	<1.0	2.8	16.8	16.8	16.8	2.8		31.8	
				WQ	299		T	194.4	197.7	197.7	3.0	8.6	17.2	17.2	17.2	8.6		28.5, 1	
				SC	306		L	204.4	197.7	197.7	3.0	8.6	15.0	15.0	15.0	8.6		29.7	
				WQ	321		T	187.1	180.7	180.7	2.0	7.5	13.9	13.9	13.9	7.5		M.D.	
				SC	363		L	189.4	184.3	184.3	3.0	10.8	15.3	15.3	15.3	10.8		M.D.	
				WQ	321		T	241.9	240.7	240.7	<1.0	3.4	15.4	15.4	15.4	3.4		463	
				SC	363		L	239.5	231.4	231.4	<1.0	6.0	17.2	17.2	17.2	6.0		406	
				WQ	347		T	192.8	189.2	189.2	1.0	7.4	17.6	17.6	17.6	7.4		441	
				SC	376		L	184.9	184.8	184.8	<1.0	5.9	18.1	18.1	18.1	5.9		401	
				WQ	347		L	186.5	184.8	184.8	2.0	5.9	17.8	17.8	17.8	5.9		428	
				SC	376		T	191.0	186.0	186.0	3.0	11.9	15.6	15.6	15.6	11.9		437	
				WQ	314		T	188.1	182.7	182.7	1.0	6.3	13.1	13.1	13.1	6.3		428	
				SC	390		L	210.8	217.4	217.4	<1.0	6.0	18.7	18.7	18.7	6.0		416	
				WQ	344		T	192.2	191.2	191.2	1.0	7.4	16.5	16.5	16.5	7.4		383	
				SC	376		L	192.0	190.0	190.0	1.0	7.4	17.5	17.5	17.5	7.4		356	
				WQ	344		T	183.2	182.3	182.3	<1.0	4.0	16.3	16.3	16.3	4.0		428	
				SC	376		L	194.8	192.3	192.3	4.0	12.2	17.2	17.2	17.2	12.2		416	
				WQ	330		T	181.9	181.0	181.0	<1.0	7.0	15.1	15.1	15.1	7.0		383	
				SC	344		L	150.8	177.0	177.0	10.0	20.7	17.3	17.3	17.3	20.7		356	
				WQ	330		T	184.8	175.6	175.6	8.0	21.6	16.5	16.5	16.5	8.0		40.0	
				SC	344		L	185.0	161.8	161.8	12.0	27.0	16.9	16.9	16.9	12.0			
				WQ	344		T	173.3	164.6	164.6	11.0	22.0	17.4	17.4	17.4	11.0			
				SC	344		L	171.8	160.8	160.8	12.0	24.6	15.9	15.9	15.9	12.0			

* -Not investigated in Phase II.
 † -Premature failure.
 ‡ -Low fracture toughness, broke during pre-cracking.
 @ -Tensile properties not determined.
 M.D. -Not determined.

TABLE XXI

PHASE II AGED MECHANICAL PROPERTY DATA
WATER QUENCHED SAMPLES

Phase I No.	Phase II No.	Composition (bal. II)	Density (lbs/in ³)	Solution Treatment (F)	Hardness As Quenched (VFN)	Aging Treatment (F)	Speci. Dir.	Ultimate Tensile Strength (ksi)	Aged Tensile Properties			Aged Hardness (VFN)	Fracture Toughness (ksi/in.)		
									Yield Strength (ksi)	Elong. of Area (%)	Redn. of Area (%)				
266	167	11Mo-4Al	0.169	1575-1 hr	248	1000-8 hr	T	208.6	172.8	1.0	4.0	17.2	404	26,27.6,25.5	
				1550-2 hr	289	1000-8 hr	L	193.8	180.4	<1.0	4.2	16.2	401	MD	44.3 (Short Trans. Fibrous)
				1500-2 hr		1050-8 hr	T	187.4	172.8	3.0	7.2	16.7		MD - Y	
261	168	9Mo-1.5Al-3Sn	0.172	1475-2 hr	245	850-8 hr	L	201.5	193.3	2.0	2.0	15.3	416	MD	
					.236	900-4 hr	T	200.8	200.8			14.3	412	†	
				1450-2 hr	256	900-4 hr	L	177.1	206.0	<1.0	4.2	14.6		†	
232	149	4Mo-8V-6Cr-2.5Al	0.171	1300-4 hr	272	850-8 hr	T	207.7	199.0	3.0	6.8	15.2	390	36.2,28.1	
				1275-4 hr	245	850-8 hr	L	203.4	197.1	3.0	9.4	14.9		30.0	
				1275-4 hr	278	1000-8 hr	L	196.8	170.3	4.0	7.6	15.3		408	MD - Y
253	170	10Mo-8V-2.5Al	0.171	1375-4 hr	262	1000-4 hr	L	147.0	122.6	10.0	38.0	11.0	393	MD - X	
				1350-4 hr	262	850-8 hr	L	147.7	130.0	6.0	27.9	12.0		372	42.0,42.2,39.4
				1325-4 hr	256	900-96 hr	L	164.5	148.9	6.0	17.0	14.5		366	MD
243	171	11Mo-1Al-0.5Si	0.172	1475-2 hr	235	950-8 hr	L	215.2	199.4	4.0	3.7	16.5	401	MD - Y	
				1450-2 hr	226	1000-4 hr	T	188.0	162.3	1.0	3.2	16.5	376	21.2 †	
				1450-2 hr	260	900-8 hr	L	173.2	211.0	3.0	3.3	15.4		†	
227	169	7Mo-4Cr-2.5Al	0.169	1450-2 hr	260	1000-8 hr	L	172.0	161.7	8.0	23.0	15.4	437	MD - Y	
				1425-4 hr	268	1100-8 hr	L	176.9	167.0	10.0	23.0	14.6		X	
				1400-4 hr	272	900-8 hr	L	146.5	141.6	12.0	31.7	14.6		X	
334	177	10Mo-6Cr-2.5Al	0.171	1325-4 hr	272	875-96 hr	T	213.6	206.8	<1.0	4.0	16.7	408	36.1,33.5	
				1300-4 hr	272	950-96 hr	L	196.8	194.0	1.0	8.2	15.7		55.1	Y
				1275-4 hr	272	975-96 hr	L	187.3	185.9	2.0		17.3		Y	76.8,68.2

TABLE XXI (Cont'd)
PHASE II AGED MECHANICAL PROPERTY DATA
WATER QUENCHED SAMPLES

Phase I No.	Phase II No.	Phase II Composition (bal. Ti)	Density (lbs/in ³)	Solution Treatment (F°)	Hardness As Quenched (VPN)	Aging Treatment (F°)	Speci. Dir.	Aged Tensile Properties				Aged Hardness (VPN)	Fracture Toughness (ksi/in.)	
								Ultimate Tensile Strength (ksi)	Yield Strength 0.2% Offset (ksi)	Elong. in 4D Area (%)	E(x10 ⁶ psi)			
337	174	4Mo-6V-4Cr-2.5Al	0.168	1350-4 hr	274	875-24 hr	T	212.2	207.1	1.0	6.6	15.5	B	28.3
							L	191.2	189.2	2.0	15.0	15.7	C	33.8
							L	204.0	196.0	6.0	10.5	15.5	A	Y
							L	204.5	197.7	2.0	10.6	14.8	A	Y
							-	--	158.5 e	--	--	--	-	49.4, 49.0
338	175	4Mo-4Cr-4Zr-6Al-2Sn	0.163	1550-2 hr	321	1050-4 hr	T	241.9	240.7	<1.0	3.4	15.4	B	†, †
							L	239.5	231.4	<1.0	6.0	17.2	B	†
							-	--	--	--	--	--	@	ND
							L	197.5	188.1	8.0	16.9	15.4	C	Y
							L	192.3	185.5	6.0	13.3	15.6	C	Y
339	176	2Mo-4V-4Cr-4Zr-6Al-2Sn	0.162	1475-2 hr	314	1050-24 hr	T	210.8	*	<1.0	6.0	18.7	C	9.6, 15.3
							L	219.7	217.4	--	--	16.5	@	ND
							-	--	--	--	--	--	@	ND
							L	179.0	169.4	6.0	0.2	14.7	C	Y
							L	165.7	160.0	4.0	0.7	14.8	A	Y
235	178	6Al-2Sn-4Zr-6Mo	0.165	1325-4 hr	344	1050-24 hr	L	198.3	198.3	3.0	2.8	17.2	C	21.4, 22.4
							L	203.0	200.4	4.0	3.0	16.8	A	
							-	--	--	--	--	--	-	
							L	188.2	180.0	8.0	9.6	17.0	C	
							L	188.2	180.0	8.0	9.6	17.0	C	
235	178	6Al-2Sn-4Zr-6Mo	0.165	1575-1 hr	330	1100-8 hr	T	184.8	177.0	10.0	20.7	17.3	B	28.6, 29.3
							L	185.0	175.6	8.0	21.6	16.5	A	34.9

* Determined by slow bend of pre-cracked Charpy samples.
† Premature failure.
‡ Low fracture toughness, broke during pre-cracking.
@ Tensile properties not determined.
ND Not determined.
X Microtensiles from Phase II plate rolled to 0.045" sheet.
Y Microtensiles from Phase I sheet.
e Estimated.
OCX Outside gage mark

TABLE XXII

AGED DYNAMIC MODULUS MEASUREMENTS
OF SELECTED ALLOYS

<u>Alloy</u>	<u>Composition (bal.Ti)</u>	<u>Direction^a</u>	<u>Dynamic Modulus, E (lb.in.⁻²)</u>
227	7Mo-4Cr-2.5Al	L T	14.8 x 10 ⁶ 15.2
232	4Mo-8V-6Cr-2.5Al	L T	12.9 14.3
240	6Mo-6V	L T	15.1 16.5
253	10Mo-8V-2.5Al	L T	14.0 14.8
261	9Mo-1.5Al-3Sn	L T	14.8 16.3
266	11Mo-4Al	L T	14.4 15.6

^a L - longitudinal
T - transverse

TABLE XXIII
CHEMICAL ANALYSIS OF PHASE II ALLOYS

Alloy No.	Phase II Ingot No.	Nominal Composition (bal. Ti)	Chemical Analysis (w/o) ^a										
			Mo	Cr	Al	V	Zr	Sn	Si	Fe	O ₂ ^c		
266	167	11Mo-4Al	11.20	-	4.20	-	-	-	-	-	-	-	0.112
261	168	9Mo-1.5Al-3Sn	9.20	-	1.80	-	-	-	3.72	-	-	-	0.102
232	149	4Mo-8V-6Cr-2.5Al	3.80	6.07	2.60	8.00	-	-	-	-	-	-	0.175
253	170	10Mo-8V-2.5Al	10.30	-	2.40	8.20	-	-	-	-	-	-	0.133
243	171	11Mo-1Al-0.5Si	10.60	-	0.90	-	-	-	-	0.50	-	-	0.109
227	169	7Mo-4Cr-2.5Al	6.70	4.18	2.70	-	-	-	-	-	-	-	0.109
216	172	8Mo-8V-2Fe-3Al	7.60	-	2.90	-	-	-	-	-	1.76	-	0.120
334	177	10Mo-6Cr-2.5Al	10.00	6.12	2.00	-	-	-	-	-	-	-	0.126
337	174	4Mo-6V-4Cr-2.5Al	3.80	4.09	3.73	6.18	-	-	-	-	-	-	0.126
338	175	4Mo-4Cr-4Zr-6Al-2Sn	4.00	4.08	6.40	-	4.12	2.31	-	-	-	-	0.103
339	176	2Mo-4V-4Cr-4Zr-6Al-2Sn	2.00	4.01	5.90	4.07	3.80	2.34	-	-	-	-	0.122
235	178	6Al-2Sn-4Zr-6Mo	6.20	-	6.20	-	4.12	2.42	-	-	-	-	0.106

^a Determined by wet chemistry unless stated otherwise.

^b Determined by atomic absorption and wet chemistry.

^c Determined by vacuum fusion.

TABLE XXIV
EXPERIMENTALLY DETERMINED
DENSITIES OF PHASE II ALLOYS

<u>Alloy No.</u>	<u>Composition</u>	<u>Density (lb.ins.⁻³)</u>	
		<u>Measured¹</u>	<u>Calculated²</u>
232	4Mo-8V-6Cr-2.5Al	0.172	0.171
266	11Mo-4Al	0.170	0.169
261	9Mo-1.5Al-3Sn	0.174	0.172
227	7Mo-4Cr-2.5Al	0.171	0.169
253	10Mo-8V-2.5Al	0.175	0.173
216	8Mo-8V-2Fe-3Al	0.174	0.172

¹ Using the hydrostatic weighing technique and following ASTM procedure B311-58.

² Obtained using the rule of mixtures calculation.

TABLE XXV

ALLOYS FOR DETAILED FINE STRUCTURE ANALYSIS AT
NORTH AMERICAN ROCKWELL SCIENCE CENTER

"Good" Alloys	Composition	Solution Treatment	Aging Temp. (F)	Aging Times ^a
227	7Mo-4Cr-2.5Al	1475F - 2 hr.	900	As Q, 1m, 5m, 8h, 48h
232	4Mo-8V-6Cr-2.5Al	1350F - 4 hr.	850	As Q, 10m, 30m, 3h, 24h
240	6Mo-6V	1325F - 4 hr.	800	As Q, 18s, 45s, 6m, 8h
243	11Mo-1Al-0.5Si	1475F - 2 hr.	950	As Q, 20s, 36s, 6m, 8h
253	10Mo-8V-2.5Al	1450F - 2 hr.	850	As Q, 20m, 1h, 48h, 96h
261	9Mo-1.5Al-3Sn	1475F - 2 hr.	850	As Q, 1m, 5m, 1½h, 8h
266	11Mo-4Al	1575F - 1 hr.	1000	As Q, 1m, 2m, 8h, 48h
"Bad" Alloys				
226	12V-2.5Al	1375F - 4 hr.	900	As Q, 12s, 30s, 12m, 8h
229	6Mo-3V-4Zr-7.5Sn	1450F - 2 hr.	950	As Q, 12s, 30s, 30m, 8h
242	5Mo-2Cr-2.5Al	1525F - 2 hr.	950	As Q, 12s, 30s, 30m, 8h

^a Samples aged to $\frac{MH}{4}$, $\frac{MH}{2}$, MH and overage, where MH is maximum hardness.

TABLE XXVI

SUMMARY OF FINE STRUCTURE ANALYSIS

Alloy No.	Composition (bal. Ti)	Solution Treatment		Temp. (F)	Temp. (F)	Phases Detected*					
		Temp. (F)	Time (hr)			β	α_p	α''	α''^*	ω	α
227	7Mo-4Cr-2.5Al	1475	2	900	✓	✓	-	✓	-	-	✓
		1425	4	900	✓	✓	-	-	-	-	✓
226	12V-2.5Al	1375	4	900	✓	✓	-	-	-	-	✓
240	6Mo-6V	1325	4	800	✓	✓	-	-	-	✓	✓
243	11Mo-1Al-0.5Si	1475	2	950	✓	✓	-	-	-	✓	✓
		1475	2	1000	✓	✓	-	-	-	✓	✓
		1425	4	950	✓	✓	-	-	-	-	✓
266	11Mo-4Al	1575	1	1000	✓	✓	-	-	-	-	✓
232	4Mo-8V-6Cr-2.5Al	1350	4	850	✓	✓	-	-	-	-	✓
		1300	4	850	✓	✓	-	-	-	-	✓
229	6Mo-3V-4Zr-7.5Sn	1450	2	950	✓	✓	-	-	✓	-	✓
261	9Mo-1.5Al-3Sn	1475	2	850	✓	✓	-	-	-	-	✓
242	5Mo-2Cr-2.5Al	1525	2	950	✓	✓	-	-	-	✓	✓
253	10Mo-8V-2.5Al	1450	2	850	✓	✓	-	-	-	-	✓

* β - beta
 α_p - primary alpha
 α'' - orthorhombic martensite
 α''^* - orthorhombic martensite which reverts either during the early stages of aging or during heating to the aging temperature.
 ω - omega
 α - alpha

TABLE XXVII

PREDICTED DUCTILITY AND TOUGHNESS
OF PHASE II ALLOYS AT
CONTRACT YIELD STRENGTH GOAL

<u>Alloy No.</u>	<u>Composition (bal. Ti.)</u>	<u>Contract^a YS Goal (ksi)</u>	<u>Corresponding</u>	
			<u>RA(%)</u>	<u>K_Q (ksi/in.)</u>
Contract Goals		170 ^b	18	60
334	10Mo-6Cr-2.5Al	171	16	64
227	7Mo-4Cr-2.5Al	169	14	56
232	4Mo-8V-6Cr-2.5Al	171	17	~52
253	10Mo-8V-2.5Al	171	12	~59
337	4Mo-6V-4Cr-2.5Al	168	19	45
261	9Mo-1.5Al-3Sn	172	31	c
338	4Mo-4Cr-4Zr-6Al-2Sn	163	15	d
339	2Mo-4V-4Cr-4Zr-6Al-2Sn	162	c	d
266	11Mo-4Al	169	c	d
243	11Mo-1Al-0.5Si	172	c	c

^a At a YS to density ratio of 1.0×10^6 inches.

^b For an alloy of density 0.170 lbs/in.³

^c Value not defined precisely but obviously significantly below goal.

^d Value not defined precisely, not considered to approach goal.

TABLE XXVIII

SUMMARY OF CORRELATION OF PROPERTIES TO MICROSTRUCTURE
OF PHASE II SIMULATED COOLED AND AGED MATERIAL^a

Alloy No.	Composition (bal. Ti)	Direction ^b	Yield Strength (ksi)	Redn. of Area (%)	K _Q (ksi/in.) ^c	Microstructure ^d	
						Sc	Fa
261	9Mo-1.5Al-3Sn	T	167	46	11		
		L	160	37	~11	small amt.	globular very fine
227	7Mo-4Cr-2.5Al	T	177	7	40		
		L	166	6	~40	present	lenticular very fine
216	8Mo-8V-2Fe-3Al	T	194	20	36		
		L	194	13	~36	present	lenticular med. fine
334	10Mo-6Cr-2.5Al	T	192	4	42		
		L	184	7	70	present	lenticular med. fine
337	4Mo-6V-4Cr-2.5Al	T	199	5	29		
		L	198	9	30	present	lenticular med. fine
235	6Al-2Sn-4Zr-6Mo	T	164	25	36		
		L	161	25	40	present	large amt. lenticular small amt. med. fine

^a For more details see Table VI.

^b L = longitudinal, T = transverse.

^c Approximate values have been estimated from data in Table VI.

^d Sc - Stringer alpha formed due to hot working.

Cx - Coarse alpha formed at the solution treatment temperature.

Fa - Fine alpha formed at the aging temperature by decomposition of the beta matrix.

TABLE XXIX

RELATIVE RANKING
OF DUCTILITY AND FRACTURE TOUGHNESS
ALLOY CHARACTERISTIC TREND LINES

<u>Alloy No.</u>	<u>Composition (bal. Ti)</u>	<u>Relative^a Ductility Ranking</u>	<u>Relative Fracture^b Toughness Ranking</u>
334	10Mo-6Cr-2.5Al	5	1
227	7Mo-4Cr-2.5Al	4	3
232	4Mo-8V-6Cr-2.5Al	3	4?
253	10Mo-8V-2.5Al	7	2?
337	4Mo-6V-4Cr-2.5Al	2	6
261	9Mo-1.5Al-3Sn	1	10?
338	4Mo-4Cr-4Zr-6Al-2Sn	6	7?
339	2Mo-4V-4Cr-4Zr-6Al-2Sn	8?	8?
266	11Mo-4Al	9	5?
243	11Mo-1Al-0.5Si	10	9?

^a From Figures 44 through 53.

^b From Figures 34 through 43.

? Best guess, characteristic trend line not defined precisely.

TABLE XXX

CHEMICAL ANALYSIS OF
PHASE III ALLOY ADDITIONS

<u>Addition</u>	<u>Oxygen</u>	<u>Nitrogen</u>	<u>Iron</u>
Ti-Sponge, RSPI-31923	0.060*	0.010*	Nil
Mo granules, Mo #5	0.219	--	0.20
Electrolytic Cr, Cr-25	0.029	--	0.9
Al-Mo master (70:30) MY13	0.108	--	0.74
Al-V master (85:15), GY-141	0.210	--	0.40

* Analysis made on 50 gram button melt. Analysis for other alloy additions made on 50 gm buttons consisting of 10% alloy addition to Ti-sponge.

TABLE XXXI

CALCULATION OF ANTICIPATED Fe AND O₂
CONTENTS* OF DEEP HARDENABLE PHASE III
500 lb. INGOTS

<u>Alloy No.</u>	<u>Composition (bal. Ti)</u>	<u>Fe (%)</u>	<u>O₂ (%)</u>
334	10Mo-6Cr-2.5Al	0.13	0.08
227	7Mo-4Cr-2.5Al	0.10	0.10
253	10Mo-8V-2.5Al	0.08	0.11

* Based on analyses reported in Table XXX.

TABLE XXXII

CHEMICAL ANALYSIS OF PHASE III ALLOYS
AT INGOT STAGE

<u>Alloy</u>	<u>Location</u>	<u>Mo</u>	<u>Cr</u>	<u>Al</u>	<u>O₂</u>
334	Goal	10	6	2.5	~0.100
	Top	9.44	6.03	2.6	0.103
	Bottom	9.44	ND*	3.5	0.106
	Collar	7.58	10.02	3.1	ND*
227	Goal	7	4	2.5	~0.100
	Top	6.85	ND*	2.6	0.123
	Bottom	6.01	ND*	ND*	ND*
	Collar	6.58	5.53	2.6	ND*
253	Goal	10	8	2.5	~0.100
	Top	10.73	7.9	2.5	ND*
	Bottom	9.02	8.4	2.5	ND*
	Collar	9.45	7.9	4.3	ND*

* Not determined.

TABLE XXXIII

CHEMICAL ANALYSIS OF PHASE III ALLOYS,
BUTT END 10.5" RCS STAGE

<u>Alloy</u>	<u>Mo</u>	<u>Cr</u>	<u>V</u>	<u>Al</u>	<u>O₂</u>	<u>H₂</u>	<u>N</u>	<u>C</u>	<u>Fe</u>
<u>334</u>									
Nominal Composition	10.0	6.0	-	2.5	-	-	-	-	-
Actual Edge	9.88	6.06	-	2.4	.132	.0031	.008	.020	.06
Actual Center	9.88	6.30	-		.135	.0027			
<u>227</u>									
Nominal Composition	7.0	4.0	-	2.5	-	-	-	-	-
Actual Edge	6.73	4.10	-	2.4	.135	.0011	.012	.024	.08
Actual Center	6.73	4.07	-	2.4	.132	.0018	.007	.017	.10
<u>253</u>									
Nominal Composition	10.0	-	8.0	2.5	-	-	-	-	-
Actual Edge	10.02	-	8.0	2.6	.166	.0010	.014	.019	.09
Actual Center	9.88	-	8.0	2.6	.168	.0004	.012	.012	.09

TABLE XXXIV

ALLOY DENSITY*

<u>Alloy</u>	<u>Composition (bal Ti)</u>	<u>Density (lb/cubic inch)</u>	
		<u>Edge</u>	<u>Center</u>
334	10Mo-6Cr-2.5Al	0.171	0.171
227	7Mo-4Cr-2.5Al	0.169	0.169
253	10Mo-8V-2.5Al	0.171	0.171

* One quarter ($\frac{1}{4}$) inch cube samples in all beta condition tested using ASTM procedure B311-58.

TABLE XXXV

BETA RECRYSTALLIZATION STUDY

<u>Alloy</u>	<u>Composition (bal Ti)</u>	<u>Beta Transus (F)</u>	<u>Anneal*</u>		<u>Percent Recrystallized</u>
			<u>Temp. (F)</u>	<u>Time (hr)</u>	
334	10Mo-6Cr-2.5Al	1425	1600	4	25
227	7Mo-4Cr-2.5Al	1525	1550	4	35-40
253	10Mo-8V-2.5Al	1425	1600	4	25-30

* Anneal for optimum recrystallization. Reduced time-temperature resulted in less recrystallization; increased time-temperature caused only an overall increase in grain size.

TABLE XXXVI

FORGING SCHEDULE FOR TMT OPTIMIZATION
TO 6 INCH DIAMETER

<u>Alloy</u>	<u>Location^a</u>	<u>Sample^b</u>	<u>Forging^c Route</u>	<u>Forge Temp. (F) *</u>	<u>Re-heat Temp. (F) *</u>	<u>Processing Code</u>	
334	C	BR	HTMT	1550	1475	A	
	C	BR	LTMT	1450	1400	B	
	C	No BR	LTMT	1450	1400	C	
	E	BR	HTMT	1500	1425	A	
	E	BR	LTMT	1400	1350	B	
	E	No BR	LTMT	1400	1350	C	
	253	C	BR	HTMT	1550	1475	A
		C	BR	LTMT	1450	1400	B
		C	No BR	LTMT	1450	1400	C
E		BR	HTMT	1550	1475	A	
E		BR	LTMT	1450	1400	B	
E		No BR	LTMT	1450	1400	C	
227		C	BR	HTMT	1650	1575	A
		C	BR	LTMT	1550	1500	B
		C	No BR	LTMT	1550	1500	C
	E	BR	HTMT	1650	1575	A	
	E	BR	LTMT	1550	1500	B	
	E	No BR	LTMT	1550	1500	C	

^a C - center; E - edge.

^b BR - beta recrystallized; No BR - no beta recrystallization.

#334: 1600F - 4 hr AC.

#227: 1550F - 4 hr AC.

#253: 1600F - 4 hr AC.

^c HTMT - high temperature thermomechanical process.
LTMT - low temperature thermomechanical process.

* Related to beta transus:

#334: 1425F

#227: 1525F

#253: 1425F

TABLE XXXVII

SOLUTION AND AGING TREATMENTS
FOR TMT OPTIMIZATION TO 6 INCH DIAMETER

<u>Alloy</u>	<u>Location^a</u>	<u>Processing^b Code</u>	<u>Heat Treatment</u>				<u>Processing and Heat Treatment Code^c</u>		
			<u>Solution</u>		<u>Age</u>				
			<u>Temp (F)</u>	<u>Time (hr)</u>	<u>Temp (F)</u>	<u>Time (hr)</u>			
334	C & E	A	1350	4	950	96	AIa		
			1350	4	900	96	AIb		
		B	1350	4	900	96	BIB		
			1300	4	900	96	BIIb		
		C	1350	4	950	96	CIa		
			1300	4	950	96	CIIa		
253	C & E	A	1325	4	950	96	AIa		
			1325	4	900	96	AIb		
		B	1325	4	900	96	BIB		
			1275	4	900	96	BIIb		
		C	1325	4	950	96	CIa		
			1275	4	950	96	CIIa		
		227	C & E	A	1475	2	975	8	AIa
					1475	4	925	8	AIb
				B	1475	2	925	8	BIB
1425	4				925	8	BIIb		
C	1475			2	975	8	CIa		
	1425			4	975	8	CIIa		

^a Center and edge samples to receive same treatment.

^b See final column of Table XXXVI.

^c First letter indicates the processing route, numeral the solution annealing treatment and final letter the aging treatment.

TABLE XXXVIII

**MECHANICAL PROPERTIES OF ALLOY 334 (10Mo-6Cr-2.5Al)
AFTER SIMULATED PROCESSING FROM 10.5" RCS TO 6" STAGE**

Location ^a	Proc. Sch. ^b	Heat Treatment		Code ^e	Mechanical Properties					KQ ^f (ksi/in.)		
		Solution ^c	Age ^d		UTS (ksi)	YS (ksi)	El (%)	RA (%)	E (x10 ⁶ psi)		Break	
Approx. Goal*					186.0	178.0	10.0	15.0			55.0	
C	A	I	a	1C	178.6	173.7	11.0	30.6	16.5	C	106.5	
			b	2C	184.9	179.8	8.0	33.2	16.7	C	101.1	
		I	a	1C	192.4	186.7	8.0	19.6	15.9	B	80.4	
			b	2C	189.9	186.1	5.0	26.6	16.0	C	91.6	
		B	I	b	3C	192.4	186.1	6.0	16.8	16.2	C	136.5
			II	b	4C	192.9	187.0	8.0	18.2	16.7	C	73.9
	C	I	a	5C	179.4	176.8	6.0	20.2	16.2	C	123.2	
			b	4C	181.9	175.9	10.0	29.2	16.2	C	114.2	
		II	a	6C	185.4	180.4	7.0	21.6	16.1	C	118.5	
			b	5C	184.6	180.1	12.0	23.8	16.9	A	104.4	
		II	a	6C	180.9	174.9	10.0	15.2	17.1	A	112.0	
			b	5C	176.9	171.9	8.0	27.2	16.8	C	85.9	
E	A	I	a	1E	181.4	175.9	9.0	28.6	16.9	C	110.4	
			b	2E	183.4	177.1	9.0	21.6	16.6	C	128.1	
		I	a	1E	205.9	198.4	7.0	15.2	17.3	A	77.9	
			b	2E	200.9	193.9	8.0	17.4	17.1	C	80.2	
		B	I	b	3E	190.9	184.3	7.0	15.2	16.7	B	77.9
			II	b	4E	201.4	194.8	12.0	12.4	17.0	C	74.8
	C	I	a	5E	192.2	186.4	7.0	12.4	17.3	B	85.1	
			b	4E	192.2	187.0	-	-	17.2	OGM	92.4	
		II	a	6E	179.2	174.3	8.0	27.8	16.7	B	83.2	
			b	5E	178.4	175.9	5.0	13.8	17.3	C	-	
		II	a	6E	177.9	173.7	6.0	18.2	16.8	C	119.3	
			b	5E	183.3	178.2	7.0	7.8	17.0	C	131.3	

^a C - center, E - edge of 10.5" RCS billet.

^b A - Beta recrystallization (BR) + high temperature thermomechanical process (HMT);
 B - BR + low temperature TMT (LTMT);
 C - No BR + LTMT.

BR: 4 hour - 1600F AC
 HMT: forge from 1550F, reheats 1475F.
 LTMT: forge from 1450F, reheats 1400F.

^c I - 1350F - 4 hours
 II - 1300F - 4 hours

^d a - 950F - 96 hours
 b - 900F - 96 hours

^e To enable direct comparison of various conditions.

^f Slow bend of precracked Charpy samples. Calculated using $KQ = \frac{W}{A} \times \frac{E}{2(1-\nu^2)}$

* To reach contract goals at center of six inch section.

TABLE XXXIX

**MECHANICAL PROPERTIES OF ALLOY 227 (7Mo-4Cr-2.5Al)
AFTER SIMULATED PROCESSING FROM 10.5" RCS TO 6" STAGE**

Location ^a	Proc. Sch. ^b	Heat Treatment		Code ^e	Mechanical Properties					Break	K _Q ^f (ksi/in.)	
		Solution ^c	Age ^d		UTS (ksi)	YS (ksi)	El (%)	RA (%)	E (x10 ³)			
Approx. Goal*					190.0	184.0	9.0	14.0			50.0	
C	A	I	a	1C	197.2	190.1	4.0	14.8	16.6	C	65.3	
			b	2C	198.6	192.2	6.0	14.2	15.9	C	84.5	
		I	a	1C	210.3	200.0	3.0	15.0	16.2	A	67.7	
			b	2C	201.5	195.0	3.0	13.2	16.1	C	60.6	
		B	I	b	3C	210.4	201.4	2.0	1.6	16.9	C	57.1
			II	b	4C	206.4	198.7	2.0	3.2	16.3	OGM	49.6
	C	I	a	5C	197.0	186.0	5.0	8.0	16.8	B	86.6	
			b	4C	198.4	188.8	8.0	20.2	17.6	B	68.5	
		II	a	6C	204.4	195.4	8.0	14.6	16.8	A	149.9	
			b	5C	202.0	192.0	8.0	19.8	17.2	A	80.0	
		II	a	6C	195.0	186.3	3.0	8.8	17.9	C	100.5	
			b	5C	191.9	183.3	9.0	18.9	16.9	C	108.8	
E	A	I	a	1E	206.4	196.9	4.0	10.0	16.9	B	82.1	
			b	2E	188.3	180.1	7.0	24.3	15.5	B	106.3	
		I	a	1E	211.5	204.3	3.0	13.2	17.4	C	63.4	
			b	2E	210.4	202.0	3.0	10.0	15.9	C	74.5	
		B	I	b	3E	210.4	203.8	2.0	4.8	16.7	OGM	114.8
			II	b	4E	205.5	196.2	6.0	13.2	17.9	A	64.9
	C	I	a	5E	203.0	190.5	6.0	14.0	17.4	B	98.1	
			b	4E	206.4	195.4	6.0	4.0	17.4	B	103.4	
		II	a	6E	206.4	198.4	-	-	17.0	OGM	123.8	
			b	5E	204.0	198.0	5.0	10.2	17.2	C	74.5	
		II	a	6E	187.4	177.4	10.0	28.6	17.4	A	110.5	
			b	5E	185.9	178.9	6.0	22.4	17.0	C	113.0	

^a C - center, E - edge of 10.5" RCS billet.

^b A - beta recrystallization (BR) + high temperature thermomechanical process (HTMT);

B - BR + low temperature TMT (LTMT);

C - no BR + LTMT.

BR: 4 hour - 1550F AC
HTMT: forge from 1650F, reheats 1575F.
LTMT: forge from 1550F, reheats 1500F.

^c I - 1475F - 2 hours

II - 1425F - 4 hours

^d a - 975F - 8 hours

b - 925F - 8 hours

^e To enable direct comparison of various conditions.

^f Slow bend of precracked Charpy samples. Calculated using $K_Q = \frac{W}{A} \times \frac{E}{2(1-\nu^2)}$

* To reach contract goals at center of six inch section.

TABLE XL

**MECHANICAL PROPERTIES OF ALLOY 253 (10Mo-8V-2.5Al)
AFTER SIMULATED PROCESSING FROM 10.5" RCS TO 6" STAGE**

Location ^a	Proc. Sch. ^b	Heat Treatment		Code ^e	Mechanical Properties					Break	K _Q ^f (ksi/in.)	
		Solution ^c	Age ^d		UTS (ksi)	YS (ksi)	El (%)	RA (%)	E (x10 ⁶ psi)			
Approx. Goal*					180.0	174.0	10.0	16.0			55.0	
C	A	I	a	1C	167.3	165.3	9.0	18.0	15.5	C	93.5	
			b	2C	164.8	162.3	-	-	15.9	OGM	104.4	
		I	a	1C	189.9	184.0	4.0	7.8	16.4	C	76.2	
			b	2C	188.7	184.3	4.0	13.0	16.2	C	77.7	
		B	I	b	3C	189.9	183.1	2.0	5.6	16.8	C	92.7
			II	b	4C	191.1	185.3	8.0	20.0	17.2	C	88.8
	C	I	a	5C	176.6	169.9	7.0	17.9	16.6	B	106.6	
			b	4C	180.0	173.7	6.0	16.2	16.4	A	117.4	
		II	a	6C	167.8	163.8	11.0	43.1	15.9	B	93.7	
			b	5C	165.3	162.0	10.0	28.3	15.9	B	83.4	
		II	a	6C	163.3	157.2	9.0	36.5	16.9	C	97.6	
			b	5C	168.8	166.8	10.0	30.7	16.3	C	117.0	
E	A	I	a	1E	177.4	171.9	4.0	5.6	17.2	B	89.0	
			b	2E	168.3	166.8	5.0	18.8	16.2	C	92.4	
		I	a	1E	176.4	171.9	6.0	21.6	15.7	A	75.7	
			b	2E	185.4	180.4	6.0	7.0	16.8	A	94.3	
		B	I	b	3E	181.7	177.7	6.0	26.5	16.8	B	84.9
			II	b	4E	195.4	183.7	2.0	4.8	19.1	C	118.1
	C	I	a	5E	183.9	178.6	8.0	16.8	18.6	C	93.4	
			b	4E	180.4	174.4	11.0	33.9	16.7	B	99.7	
		II	a	6E	177.9	173.2	8.0	15.0	17.3	B	80.6	
			b	5E	176.2	171.7	6.0	18.1	18.4	C	70.2	
		II	a	6E	153.8	151.2	8.0	32.5	16.0	C	110.1	
			b	5E	166.0	-	-	-	-	OGM	96.0	

^a C - center, E - edge of 10.5" RCS billet.

^b A - Beta recrystallization (BR) + high temperature thermomechanical process (HTMT);
B - BR + low temperature TMT (LTMT);
C - No BR + LTMT.

BR: 4 hour - 1600F AC

HTMT: forge from 1550F, reheats 1475F

LTMT: forge from 1450F, reheats 1400F

^c I - 1325F - 4 hours

II - 1275F - 4 hours

^d a - 950F - 96 hours

b - 900F - 96 hours

^e To enable direct comparison of various conditions.

^f Slow bend of precracked Charpy samples. Calculated using $K_Q = \frac{W}{A} \times \frac{E}{2(1 - \nu^2)}$

* To reach contract goals at center of six inch section.

TABLE XII

HARDNESS OF ALLOY 334 (10Mo-6Cr-2.5Al)
AFTER DUPLEX HEAT TREATMENT CYCLES

Aging Treatments ^a			Temp (F)	Time (hrs)	III		Hardness (V _{PN})	UTS (ksi)
I	II	Temp (F)			Time (hrs)	Temp (F)		
--	--	--	--	--	925	8	311	400† Goal 188
--	--	--	--	--	925	24	332	
--	--	--	--	--	925	96	350 [ⓐ]	
650	8	--	--	925	8	335	341	
650	8	--	--	925	24	344	344	
650	8	--	--	925	96	350	350	
650	24	--	--	925	8	359	359	
650	24	--	--	925	24	353	353	
650	24	--	--	925	96	366	366	
--	--	750	8	925	8	372	372	
--	--	750	8	925	24	363	363	
650	8	750	8	925	8	*	*	
650	8	750	8	925	24			

^a After solution treatment 1300F - 4 hours WQ.

* Sample lost.

† Calculated from UTS value (Second Interim, page 43).

ⓐ UTS after this treatment was 179 ksi (Fifth Interim, page 32).

TABLE XLII

FURTHER MECHANICAL PROPERTIES OF ALLOY 334 (10Mo-6Cr-2.5Al)
AFTER SIMULATED PROCESSING FROM 10.5" RCS TO 6" STAGE

Location ^a Sch.	Proc. b Sch.	Heat Treatment				Code ^c	UTS (ksi)	YS (ksi)	El (%)	RA (%)	E (x10 ⁶ psi)	Break	K _Q ^d (ksi/in.)	
		Solution Temp. (F)	Time (hr)	Pre-Age Temp. (F)	Time (hr)									Age Temp. (F)
Approx. Goal*														
C	A	1350	4	750	8	8	925	8	7C	186.0	178.0	10.0	15.0	55.0
E										195.4	190.9	3.0	16.0	69.2
										195.6	188.6	7.0	17.8	68.0
										202.5	197.7	6.0	8.0	61.8
										197.9	193.6	-	15.9	66.1
C	B	1350	4	750	8	8	1025	8	8C	173.0	169.6	16.0	36.8	81.4
E										177.3	174.8	8.0	19.6	74.2
										167.2	164.5	14.0	29.3	91.1
										170.0	166.0	8.0	17.1	129.8
C	C	1250	4	750	8	8	925	8	9C	169.0	164.1	10.0	31.6	96.6
E										170.3	167.7	10.0	26.7	115.6
										178.1	172.7	12.0	35.0	114.2
										172.6	168.2	10.0	21.2	109.3

^a C - center, E - edge of 10.5" RCS billet.

^b A - Beta recrystallization (BR) + high temperature thermomechanical process (HTMT);
B - BR + low temperature TMT (LTMT);
C - No BR + LTMT.

BR: 4 hour - 1600F AC

HTMT: forge from 1550F, reheats 1475F.

LTMT: forge from 1450F, reheats 1400F.

^c To enable direct comparison of various conditions.

^d Slow bend of precracked Charpy samples. Calculated using $K_Q = \frac{W}{A} \times \frac{E}{2(1-\nu^2)}$

* To reach contract goals at center of six inch section.

TABLE XLIII

FURTHER MECHANICAL PROPERTIES OF ALLOY 253 (10Mo-8V-2.5Al)
AFTER SIMULATED PROCESSING FROM 10.5" RCS TO 6" STAGE

Location ^a	Proc. b Sche.	Heat Treatment				Code ^c	Mechanical Properties					KQ ^d (ksi/in.)			
		Solution Treatment		Pre-Age			UTS (ksi)	YS (ksi)	E1 (%)	RA (%)	E (x10 ⁶ psi)		Break		
		Temp. (F)	Time (hr)	Temp. (F)	Time (hr)										
Approx. Goal*						180.0	174.0	10.0	16.0			55.0			
C	C	1275	4	750	8	900	8	7C	176.9	169.8	10.0	21.0	13.9	B	75.7
E								7E	175.9	168.9	9.0	22.4	13.8	A	73.3
									179.4	174.3	5.0	17.4	16.6	C	87.1
									182.9	175.9	5.0	13.8	16.9	C	78.2

^a C - center, E - edge of 10.5" RCS billet.

^b A - Beta recrystallization (BR) + high temperature thermomechanical process (HTMT);

B - BR + low temperature TMT (LTMT);

C - No BR + LTMT.

BR: 4 hour - 1600F AC.

HTMT: forge from 1550F, reheats 1475F.

LTMT: forge from 1450F, reheats 1400F.

^c To enable direct comparison of various conditions.

^d Slow bend of precracked Charpy samples. Calculated using $K^2 = \frac{W}{A} \times \frac{E}{2(1-\nu^2)}$

* To reach contract goals at center of six inch section.

TABLE XLIV

FURTHER MECHANICAL PROPERTIES OF ALLOY 227 (7Mo-4Cr-2.SAl)
AFTER SIMULATED PROCESSING FROM 10.5" RCS TO 6" STAGE

Location ^a	Proc. Sch. ^b	Heat Treatment				Code ^c	Mechanical Properties					K _Q ^d (ksi/in.)		
		Solution Treatment Temp. (F)	Pre-Age Time (hr)	Temp. (F)	Age Time (hr)		UTS (ksi)	YS (ksi)	El (%)	RA (%)	E (x10 ⁶ psi)		Break	
Approx. Goal*														
C	C	1475	2	--	--	1000	8	7C	190.0	184.0	9.0	14.0		50.0
E									200.4	186.4	6.0	11.4		82.0
									195.4	189.4	5.0	15.6		75.5
									185.4	177.4	8.0	27.7		103.3
									192.9	183.4	4.0	9.2		66.3
C	C	1475	2	-	-	1025	8	8C	196.4	190.6	8.0	15.2		74.4
E									192.9	186.4	8.0	22.4		80.0
									191.2	187.0	-	-		99.7
									184.9	178.3	11.0	12.8		108.5
C	C	1400	4	--	--	925	8	9C	194.4	186.4	5.0	14.2		77.3
E									194.4	184.9	5.0	22.4		67.9
									196.4	187.9	-	-		98.1
									189.4	180.4	5.0	26.6		117.5
C	C	1375	4	--	--	925	8	10C	194.4	186.4	-	-		83.9
E									180.8	168.0	5.0	16.0		84.1
									187.9	178.9	8.0	24.6		130.1
									185.4	175.9	8.0	29.0		50.8
C	A	1475	2	925	2	1025	8	11C	188.4	183.9	8.0	14.5		86.2
E									175.9	171.3	12.0	55.1		75.8
									194.7	187.1	5.0	10.5		74.7
									190.2	183.2	6.0	9.1		81.4
C	B	1475	2	--	--	1050	8	12C	181.4	175.6	10.0	36.5		145.5
E									184.6	176.6	10.0	23.5		132.7
									188.1	181.1	10.0	26.4		120.3
									187.4	180.3	8.0	22.4		106.3

^a C - center, E - edge of 10.5" RCS billet.

^b A - beta recrystallization (BR) + high temperature thermomechanical process (HTMT);
B - BR + low temperature TMT (LTMT);
C - no BR + LTMT.

BR: 4 hour - 1550F AC

HTMT: forge from 1650F, reheats 1575F

LTMT: forge from 1550F, reheats 1500F

^c To enable direct comparison of various conditions.

^d Slow bend of precracked Charpy samples. Calculated using $K^2 = \frac{W \times E}{A \times 2(1-\nu^2)}$

* To reach contract goals at center of six inch section.

TABLE XLV

SUMMARY OF TMT OPTIMIZATION STUDY,*
10.5 INCH RCS TO 6 INCH DIAMETER ROUND

<u>Alloy</u>	<u>Optimum TMT</u>			
	<u>RA Code</u>	<u>K_Q Code</u>	<u>Code^a</u>	<u>Overall Treatment</u>
334	A1b	A1Ib	A1Ib	BR + Hi Proc. + Lo ST + Lo Age
227	C1b	CI-	C1b	No BR + Lo Proc. + Hi ST + Lo Age
253	C1Ib	B1b	B1Ib	BR + Lo Proc. + Lo ST + Lo Age

* See Tables XXXVI - XL and XLII - XLIV and Figures 77 - 82, where details of treatments and coding are given.

^a Note that only in the case of alloy 253 is the overall optimum treatment actually shown in the figure, B1Ib (#4 Figures 81 and 82).

TABLE XLVI

OPTIMUM TMT TO CONVERT BLOOMS FROM
10.5 INCH RCS TO 6 INCH ROUND BILLETS

Alloy 334(10Mo-6Cr-2.5Al)

1. Beta recrystallize 4 hr. at 1600F.
2. Upset forge from 1550F and draw out to 6½" bar, reheats at 1475F.
3. With a subsequent 1300F - 4 hr. solution treatment and 900F - 96 hour age anticipated longitudinal edge properties:
180 ksi (YS) 25% (RA) 110 ksi/in. (K_QLT or LS)

Alloy 227(7Mo-4Cr-2.5Al)

1. No beta recrystallization.
2. Upset forge from 1550F and draw out to 6½" bar, reheats at 1500F.
3. With a subsequent 1475F - 2 hr. solution treatment and 1025F - 8 hr. age, anticipated longitudinal edge properties:
185 ksi (YS) 18% (RA) 90 ksi/in. (K_Q LT or LS)

Alloy 253(10Mo-8V-2.5Al)

1. Beta recrystallization 4 hr. at 1600F.
2. Upset forge from 1450F and draw out to 6½" bar, reheats at 1400F.
3. With a subsequent 1275F - 4 hr. solution treatment and 900F - 96 hr. age, anticipated longitudinal edge properties:
174 ksi (YS) 21% (RA) 103 ksi/in. (K_Q LT or LS)

TABLE XLVII
MECHANICAL PROPERTIES OF ALLOY 334 (10Mo-6Cr-2.5Al)
AT 6" STAGE, SAMPLES FROM BUTT END SLICES

Solution Treatment Temp. Time (F) (hr)	Cool Route ^a	Aging		Loc. ^b	Dirn. ^c	Mechanical Properties						K _Q ^d		
		Temp. (F)	Time (hr)			UTS (ksi)	YS (ksi)	E1 (%)	RA (%)	E (x10 ⁶ psi)	Break	LR	LT	SR
1300 4	SC	900	96	C	L	183.9	176.2	10.0	30.6	15.5	C	106.4	-	-
						173.9	165.3	14.0	29.9	14.9	C	90.6	-	-
						177.9	171.3	4.0	13.0	15.7	C	-	-	60.7
	WQ	700F - 62 secs. then air cool	T	187.4	177.4	3.0	6.4	16.7	A	-	-	53.4	-	-
				183.9	177.4	12.0	27.7	15.3	A	97.7	-	-		
				191.9	178.6	6.0	11.6	15.6	B	87.9	98.7	-	-	
E	900F - 58 secs.	L	193.9	186.4	8.0	17.8	16.1	C	80.3	126.7	-	-		
			193.4	185.8	1.0	5.4	16.5	B	-	-	49.1	51.7		
C	1100F - 118 secs.	L	194.4	184.9	2.0	2.0	16.0	C	-	-	65.3	48.6		
			194.4	184.9	2.0	2.0	16.0	C	-	-	65.3	48.6		

^a SC - Simulated cool: 1100F - 118 secs.
 900F - 58 secs.
 700F - 62 secs.
 then air cool

WQ - Water quench

^b Location: C - Center; E - Edge.

^c Direction: L - Longitudinal; T - Transverse.

^d Calculated from slow bend precracked Charpy samples using $K_Q = \frac{W}{A} \times \frac{E}{2(1-\nu^2)}$

* Used for structural analysis.

TABLE XLVIII
MECHANICAL PROPERTIES OF ALLOY 227 (7Mo-4Cr-2.5Al)
AT 6" STAGE, SAMPLES FROM BUTT END SLICES

Solution Treatment Temp. Time (F) (hr)	Cool Route ^a	Aging Temp. Time (F) (hr)	Loc. ^b	Dim. ^c	Mechanical Properties						K _Q ^d		
					UTS (ksi)	YS (ksi)	E1 (%)	RA (%)	E (x10 ⁶ psi)	Break	LR	LT	SR
1475 2	SC	1025 8	C	L	183.9	169.2	12.0	30.6	16.0	C	86.2	-	-
					183.9	168.2	10.0	27.3	15.8	C	96.2	-	-
					188.4	175.0	2.0	4.8	17.6	C	-	-	53.5
					188.4	161.4	4.0	11.6	15.2	C	-	-	66.3
WQ	E	900 96 plus 1050 8	L	177.4	171.4	10.0	30.1	14.7	C	56.6*	69.7	-	
				183.4	175.6	6.0	16.8	15.0	C	61.9	74.6	-	
				177.9	172.2	4.0	15.2	14.5	C	-	-	54.9*	54.4
				177.4	170.1	3.0	9.4	14.8	C	-	-	47.0	-
WQ	E	1050 8	L	185.9	175.6	9.0	28.5	15.2	B	85.3	-	-	
				191.9	184.9	7.0	22.8	15.0	C	72.2*	69.1	-	
				187.4	180.1	12.0	32.1	15.2	C	83.7	68.2	-	
				185.9	179.2	7.0	6.0	15.4	C	-	-	37.5	34.3
WQ	E	1050 8	L	195.4	185.8	3.0	6.4	15.2	C	-	-	43.6*	

^a SC - Simulated cool: 1275F - 117 secs.
 1075F - 50 secs.
 875F - 55 secs.
 then air cool

WQ - Water quench

^b Location: C - Center; E - Edge

^c Direction: L - Longitudinal; T - Transverse

^d Calculated from slow bend precracked Charpy samples using $K_Q^2 = \frac{W}{A} \times \frac{E}{2(1-\nu^2)}$

* Used for structural analysis.

TABLE XLIX

MECHANICAL PROPERTIES OF ALLOY 253 (10Mo-8V-2.5Al)
AT 6" STAGE, SAMPLES FROM BUTT END SLICES

Solution Treatment Temp. (F)	Time (hr)	Cool Route ^a	Aging Temp. (F)	Time (hr)	Loc. ^b	Dirn. ^c	Mechanical Properties						K _Q ^d			
							UTS (ksi)	YS (ksi)	EI (%)	RA (%)	E (x10 ⁶ psi)	Break	LR	LT	SR	SL
1275	4	SC	900	96	C	L	172.3	163.8	14.0	41.9	15.3	C	79.0	-	-	-
						T	180.8	173.4	12.0	32.5	15.6	C	88.4	-	-	-
							173.3	166.2	4.0	16.8	15.1	C	-	-	60.2	-
							179.4	171.3	5.0	11.6	14.7	C	-	-	74.1	-
							183.9	175.9	13.0	29.9	15.0	C	104.5	-	-	-
		WQ				L	177.4	172.2	7.0	31.3	14.7	C	81.7	84.6	-	-
						E	179.9	171.9	8.0	29.9	16.0	C	74.4*	131.3	-	-
						T	178.4	167.7	3.0	7.0	15.6	C	-	-	44.6	41.1
							171.3	165.3	3.0	19.6	15.3	C	-	-	50.9*	48.6

^a SC - Simulated cool: 1075F - 120 secs.
875F - 58 secs.
675F - 64 secs.
then air cool

WQ - Water quench

^b Location: C - Center; E - Edge

^c Direction: L - Longitudinal; T - Transverse

^d Calculated from slow bend precracked Charpy samples using $K_Q^2 = \frac{W}{A} \times \frac{E}{2(1-\nu^2)}$

* Used for structural analysis.

TABLE L

MECHANICAL PROPERTIES OF ALLOY 334 (10Mo-6Cr-2.5Al)
AT 10.5" STAGE, SAMPLES FROM BUTT END

Heat Treatment				Mechanical Properties								
Solution Treatment ^a		Age		Tensile			K _Q ^c					
Temp. (F)	Time (hr)	Temp. (F)	Time (hr)	UTS (ksi)	YS (ksi)	E1 (%)	RA (%)	E (x 10 ⁶ psi)	Break	RW	(ksi/in.)	SL
1300	4	900	96	179.9	177.4	5.0	13.0	17.0	A	98.7	-	59.9*
-	-	-	-	190.9	183.4	3.0	9.4	17.6	C	-	-	-
-	-	-	-	186.1	180.4	4.0	7.8	16.7	C	-	-	-
-	-	-	-	209.3	201.8	3.0	5.4	16.8	C	57.8	-	-
-	-	-	-	206.9	201.4	2.0	6.4	17.0	C	-	-	47.1
-	-	-	-	209.4	204.4	2.0	7.0	15.9	C	-	-	47.3

^a Followed by a WQ

^b L - longitudinal
T - transverse

^c Calculated from slow bend precracked Charpy samples using $K_Q^2 = \frac{W}{A} \times \frac{E}{2(1-\nu^2)}$

* Used for structural analysis.

TABLE LI

MECHANICAL PROPERTIES OF ALLOY 227 (7Mo-4Cr-2.5Al)
AT 10.5" STAGE, SAMPLES FROM BUTT END

Heat Treatment		Mechanical Properties								
Solution Temp. (F)	Time (hr)	Age Temp. (F)	Time (hr)	Tensile			Break	K ₀ ^c (ksi/in.)		
				UTS (ksi)	YS (ksi)	El (%)			RA (%)	E (x 10 ⁶ psi)
1475	2	1025	8	191.4	183.4	4.0	13.0	15.7	B	52.6
-	-	-	-	186.4	178.9	3.0	11.6	15.3	A	-
-	-	-	-	194.3	187.6	1.0	7.6	16.0	OGM	-
-	-	-	-	151.1	144.6	10.0	31.1	16.0	C	105.9
-	-	-	-	155.6	145.5	8.0	27.1	15.6	A	-
-	-	-	-	155.8	146.4	5.0	10.8	16.2	A	-

^a Followed by a WQ

^b L - longitudinal
T - transverse

^c Calculated from slow bend precracked Charpy samples using $K_Q^2 = \frac{W}{A} \times \frac{E}{2(1-\nu^2)}$

* Used for structural analysis.

TABLE LII

RECRYSTALLIZATION KINETICS STUDY OF ALLOYS
334(10Mo-6Cr-2.5Al) AND 227(7Mo-4Cr-2.5Al)
AT 6 INCH BILLET STAGE

<u>Alloy</u>	<u>BT</u> <u>(°F)</u>	<u>Temperature^a</u> <u>(°F)</u>	<u>Annealing Times^b</u>	
			<u>Mins.</u>	<u>Hours</u>
334	1425	1525	5	0.5, 5
		1400	-	0.5, 5
227	1525	1575	5	0.5, 5
		1500	-	0.5, 5

^a Followed by a water quench.

^b At temperature.

TABLE LIII

MECHANICAL PROPERTIES OF ALLOY 334 (10Mo-6Cr-2.5Al)
 AT 6" STAGE, SUPRA-TRANSUS RECRYSTALLIZED PRIOR TO HEAT TREATMENT,
 SAMPLES FROM BUTT END

Recrystallization		Heat Treatment			Mechanical Properties								
Anneal ^a		Solution Treatment ^a		Age		Tensile			K _Q				
Temp. (F)	Time (hr)	Temp. (F)	Time (hr)	Temp. (F)	Time (hr)	UTS (ksi)	YS (ksi)	E1 (%)	RA (%)	E (x 10 ⁶ psi)	Break	LR	SL
1525	1	-	-	900	96	212.9	205.3	2.0	7.0	16.4	A	49.4	-
						197.8	197.3	2.0	5.4	15.7	A	-	44.2
						222.9	222.4	2.0	5.6	16.9	OGM	-	40.2
		1300	4			172.3	166.9	4.0	14.3	16.1	C	57.9	-
						182.7	177.7	2.0	5.4	16.3	A	-	44.6*
						182.6	178.1	2.0	6.6	16.1	C	-	45.5*

^a Followed by a WQ

^b L - longitudinal
 T - transverse

^c Calculated from slow bend precracked Charpy samples using $K_Q^2 = \frac{W}{A} \times \frac{E}{2(1-\nu^2)}$

* Used for structural analysis.

TABLE LIV

MECHANICAL PROPERTIES OF ALLOY 227 (7Mo-4Cr-2.5Al)
 AT 6" STAGE, SUPRA-TRANSUS RECRYSTALLIZED PRIOR TO HEAT TREATMENT
 SAMPLES FROM BUTT END

Recrystallization Anneal ^a		Heat Treatment ^a			Mechanical Properties									
Temp. (F)	Time (hr)	Solution Temp. (F)	Time (hr)	Temp. (F)	Age Time (hr)	Dirn. ^b	UTS (ksi)	YS (ksi)	EI (%)	RA (%)	E (x 10 ⁶ psi)	Break	K _{IC} (ksi/in.)	
													LR	SL
1575	0.5	-	-	1025	8	L	192.4	184.1	3.0	6.0	15.8	C	60.4	-
						T	190.2	185.6	2.0	4.5	15.1	A	-	54.6
							195.4	184.3	1.0	4.8	15.2	C	-	50.5
		1475	2			L	189.0	180.1	1.0	5.4	15.0	A	56.9	-
						T	199.0	190.4	1.0	6.2	15.9	A	-	39.3
							193.8	185.8	1.0	6.2	15.4	A	-	43.4*

^a Followed by a WQ

^b L - longitudinal
 T - transverse

^c Calculated from slow bend precracked Charpy samples using $K_{IC}^2 = \frac{W}{A} \times \frac{E}{2(1-\nu)}$

* Used for structural analysis.

TABLE LV

MECHANICAL PROPERTIES OF ALLOY 227 (7Mo-4Cr-2.5Al)
GIVEN AN ISOTHERMAL TREATMENT PRIOR TO AGING.
SAMPLES AT 6" STAGE BUTT END SLICE

Annealing Treatment		Age		Direction ^b	Tensile Properties					Break		
First ^a Temp. (F)	Time (hr)	Temp. (F)	Time (hr)		UTS (ksi)	YS (ksi)	E1 (%)	RA (%)	E (x 10 ⁶ psi)			
1500	2	1425	0.25	925	8	T	198.4	190.0	1.0	5.6	15.0	C
						T	209.4	198.4	2.0	5.6	16.0	C
						T	184.0	165.3	4.0	12.6	15.7	C
						T	189.4	182.8	-	-	15.1	OGM

^a Directly transferred to Second Furnace (isothermally).

^b T - transverse.

TABLE LVI

FURTHER MECHANICAL PROPERTIES OF ALLOY 227(7Mo-4Cr-2.5Al)
GIVEN AN ISOTHERMAL TREATMENT PRIOR TO AGING
SAMPLES AT 6" STAGE BUTT END SLICE

First ^a		Second ^b		Third ^a		Fourth ^b		Age Temp. (F)	Time (hr)	Direction ^c	UTS (ksi)	YS (ksi)	Tensile Properties			Break
Temp. (F)	Time (hr)	Temp. (F)	Time (hr)	Temp. (F)	Time (hr)	Temp. (F)	Time (hr)						El (%)	RA (%)	E (x10 ⁶ psi)	
1500	5	1425	0.25	-	-	-	-	1025	8	T	184.7	176.0	3.0	4.7	17.0	A
											184.0	177.7	2.0	6.2	17.3	C
1500	5	1425	1	-	-	-	-	1000	8	T	184.8	178.0	2.0	11.6	18.4	C
											185.5	180.8	2.0	9.1	17.6	C
1500	2	1425	1	1500	3	1425	0.25	1025	8	T	181.1	173.8	4.0	5.8	17.6	B
											186.6	184.9	4.0	8.6	16.9	C

^a Directly transferred to next furnace (isothermally).

^b Air cooled.

^c T - transverse.

TABLE LVII

ADDITIONAL* MECHANICAL PROPERTIES OF ALLOY 227 (7Mo-4Cr-2.5Al) AT 6" STAGE
 DUPLEX ISOTHERMAL (HIGH-LOW) ANNEAL PRIOR TO AGE, SAMPLES FROM BUTT END

Annealing Treatment		Age		Direction ^c	UTS (ksi)	YS (ksi)	Tensile Properties				Break	
First ^a Temp. Time (F) (hr)	Second ^b Temp. Time (F) (hr)	Temp. (F)	Time (hr)				E1 (%)	RA (%)	($\times 10^6$ psi)	E		
1500	5	1325	2	950	8	T	158.6	144.8	4.0	9.7	15.9	C
				1000	8	T	163.0	150.9	4.0	11.3	17.4	A
							156.7	147.8	8.0	8.2	16.2	B
							150.1	143.7	10.0	26.4	16.0	B

* Isothermal treatments revised on basis of promising normal high-low annealing.

a Directly transferred to next furnace (isothermally).

b Air cooled.

c L - longitudinal, T - transverse.

TABLE LVIII

MECHANICAL PROPERTIES OF ALLOY 334 (10Mo-6Cr-2.5Al) AT 6" STAGE
 DUPLEX (LOW-HIGH) ANNEAL PRIOR TO AGE, SAMPLES FROM BUTT END

Annealing Treatment				Age Temp. (F)	Age Time (hr)	Dirn. ^b	Tensile					Mechanical Properties			
Low ^a Temp. (F)	Time (hr)	High Temp. (F)	Time (hr)				UTS (ksi)	YS (ksi)	El (%)	RA (%)	E (x10 ⁶ psi)	Break	LR (ksi/in.)	SR	K _{IC}
1250	8	1350	100	-	950	96	T	170.3	170.0	4.0	7.8	15.7	C	-	36.6
							L	180.8	175.6	2.0	7.0	15.8	C	-	127.3?
								174.5	172.1	12.0	33.9	15.3	B	118.2	-
1250	8	1375	24	1325	100	950	T	170.5	167.4	2.0	6.2	15.5	A	-	57.1*
							L	175.9	173.4	2.0	6.6	17.0	C	-	63.5
								168.9	165.5	14.0	31.3	15.2	A	94.6	-

* Used for structural analysis.

^a Followed by a water quench.

^b L - longitudinal, T - transverse.

^c Calculated from slow bend precracked Charpy samples using $K_{IC}^2 = \frac{W}{A} \times \frac{E}{2(1-\nu^2)}$

? Questionable value.

TABLE LIX

MECHANICAL PROPERTIES OF ALLOY 227 (7Mo-4Cr-2.5Al) AT 6" STAGE
 DUPLEX (LOW-HIGH) ANNEAL PRIOR TO AGE, SAMPLES FROM BUTT END

Annealing Treatment				Mechanical Properties										
Temp. (F)	Time (hr)	High		Age Temp. (F)	Age Time (hr)	Dirn. ^b	Tensile			E (x10 ⁶ psi)	Break	K _Q ^c		
		Temp. (F)	Time (hr)				YS (ksi)	El (%)	RA (%)			LR	SR	
1350	8	1450	100	-	-	T	175.9	171.2	1.0	5.6	16.3	C	-	46.9
							180.8	180.6	-	-	15.6	OGM	-	51.4
1350	8	1475	24	1425	100	T	172.0	165.4	3.0	9.1	15.3	C	-	40.4
							174.2	167.1	3.0	12.1	15.1	C	-	35.6 *

* Used for structural analysis.

^a Followed by a water quench.

^b L - longitudinal, T - transverse.

^c Calculated from slow bend precracked Charpy samples using $K_Q = \frac{W}{A} \times \frac{E}{2(1-\nu^2)}$

TABLE LX

MECHANICAL PROPERTIES OF ALLOY 334(10Mo-6Cr-2.5Al)
 AT 6" STAGE, DUPLEX (HIGH-LOW) ANNEAL PRIOR TO AGE,
 SAMPLES FROM BUTT END

Annealing Treatment				Mechanical Properties										
High ^a		Low ^a		Age		Dirn. ^b	UTS (ksi)	YS (ksi)	Tensile Properties			K _Q ^c (ksi/in)		
Temp. (F)	Time (hr)	Temp. (F)	Time (hr)	Temp. (F)	Time (hr)				E1 (%)	R/A (%)	E (x10 ⁶ psi)	LR	SR	
										Break				
1350	4	1200	4	900	96	L	157.9	150.4	18.0	36.2	16.9	B	161.5	-
							149.7	144.3	19.0	41.3	17.2	B	154.2	-
						T	153.9	151.0	10.0	26.7	15.8	C	-	82.9
							151.3	147.2	11.0	20.2	14.1	C	-	83.0*

^a Followed by a water quench.

^b L - longitudinal; T - transverse

^c Calculated from slow bend precracked Charpy samples using $K_Q^2 = \frac{W}{A} \times \frac{E}{2(1-\nu^2)}$

* Used for structural analysis.

TABLE LXI

MECHANICAL PROPERTIES OF ALLOY 227 (7Mo-4Cr-2.5Al)
 AT 6" STAGE, DUPLEX (HIGH-LOW) ANNEAL PRIOR TO AGE,
 SAMPLES FROM BUTT END

Annealing Treatment				Age Temp. (F)	Age Time (hr)	Direction ^b	Mechanical Properties						
High ^a Temp. (F)	Time (hr)	Low ^a Temp. (F)	Time (hr)				UTS (ksi)	YS (ksi)	E1 (%)	RA (%)	E (x10 ⁶ psi)	Break	K _Q ^c (ksi/in)
											LR	SR	
1450	2	1250	4	950	8	L	148.9	144.9	23.0	56.5	16.4	186.1	-
							149.4	146.7	24.0	60.0	16.6	172.6	-
						T	149.2	145.8	10.0	45.4	16.6	-	86.2*
							151.2	147.2	10.0	43.0	17.7	-	86.1*

^a Followed by a water quench.

^b L - longitudinal; T - transverse.

^c Calculated from slow bend pre-cracked Charpy samples using $K_Q^2 = \frac{W}{A} \times \frac{E}{2(1-\nu^2)}$

* Used for structural analysis.

TABLE LXII

FURTHER MECHANICAL PROPERTIES OF ALLOY 334 (10Mo-6Cr-2.5Al) AT 6" STAGE
DUPLIX (HIGH-LOW) ANNEAL PRIOR TO AGE, SAMPLES FROM BUTT END

Annealing Treatment		Age		Direction ^b	UTS (ksi)	YS (ksi)	E1 (%)	RA (%)	E (x10 ⁶ psi)	Break
High ^a Temp. (F)	Time (hr)	Low ^a Temp. (F)	Time (hr)							
1350	4	1250	4	T	176.8	175.1	4.0	6.2	16.2	C
					178.4	173.1	4.0	4.8	16.5	A

^a Followed by a water quench.

^b L - longitudinal; T - transverse.

TABLE LXIII

FURTHER MECHANICAL PROPERTIES OF ALLOY 227 (7Mo-4Cr-2.5Al) AT 6" STAGE
 DUPLEX (HIGH-LOW) ANNEAL PRIOR TO AGE, SAMPLES FROM BUTT END

Annealing Treatment		Age		Tensile Properties					Break
High Temp. (F)	Time (hr)	Low Temp. (F)	Time (hr)	UTS (ksi)	YS (ksi)	EI (%)	RA (%)	E (x10 ⁶ psi)	
1450	2	1325	8	155.9	153.9	-	-	15.4	OGM
				172.0	169.0	8.0	24.1	16.8	B
				164.5	162.8	6.0	28.7	16.7	C
				172.3	167.4	3.0	10.0	16.1	C

a Followed by a water quench.

b L - longitudinal; T - transverse.

TABLE LXIV

HEAT TREATMENT OF SIX INCH BILLET

<u>Alloy</u>	<u>Composition (bal. Ti)</u>	<u>Heat Treatment</u>					
		<u>Anneal</u>				<u>Age^b</u>	
		<u>High^a</u>		<u>Low^a</u>		<u>Temp. Time</u>	
<u>Temp. (F)</u>	<u>Time (hr)</u>	<u>Temp. (F)</u>	<u>Time (hr)</u>	<u>Temp. (F)</u>	<u>Time (hr)</u>	<u>Temp. (F)</u>	<u>Time (hr)</u>
334	10Mo-6Cr-2.5Al	1350	4	1225	2	900	96
227	7Mo-4Cr-2.5Al	1450	2	1350	8	925	8
253	10Mo-8V-2.5Al	1350	4	1225	2	900	96

^a Followed by WQ.

^b Followed by AC.

TABLE LXV

ANTICIPATED* AND GOAL TRANSVERSE PROPERTIES
AT CENTER OF SIX INCH DIAMETER BILLET

<u>Alloy</u>		<u>UTS</u> <u>(ksi)</u>	<u>YS</u> <u>(ksi)</u>	<u>EI</u> <u>(%)</u>	<u>RA</u> <u>(%)</u>	<u>K_{Ic}</u> <u>(ksi/in)</u>
334	Anticipated:	165-170	160-165	5-8	12-18	62-68
	Goal:	182	171	12	18	60
227	Anticipated:	165-170	162-167	7-10	20-24	62-68
	Goal:	186	169	12	18	60
253	Anticipated:	165-170	160-165	5-8	12-18	62-68
	Goal:	188	171	12	18	60

* Using the duplex anneal - aging sequence defined in Table LXIV.

TABLE LXVI

ROOM TEMPERATURE TENSILE PRECRACKED CHARPY TOUGHNESS AND FRACTURE TOUGHNESS PROPERTIES*
OF SIX INCH BILLET OF ALLOY #334 (10Mo-6Cr-2.5Al)

Location ^a	Direction ^b	Mechanical Properties										K _{IC} ^d (ksi/in.) SR ^e SLE
		Tensile					Charpy					
		UTS (ksi)	YS (ksi)	E1 (%)	RA (%)	E (x10 ⁶ psi)	Break	LR ^c (ksi/in.) SLE	KQ ^c (ksi/in.) SLE	SR ^e SLE	SLE	
E	L	157.9	153.9	36.0	49.5	16.0	B	125.8	-	-	-	
	T	158.4	154.8	34.0	56.5	16.7	C	141.0†	-	-	-	
	L	158.9	151.5	10.0	22.3	15.4	A	-	59.3	-	-	
	T	155.2	148.8	20.0	24.3	15.6	C	-	58.6†	-	-	
M	L	150.9	150.6	32.0	45.3	15.9	B	129.2	-	-	-	
	T	148.9	144.9	34.0	54.3	16.5	B	154.1	-	-	-	
	L	157.7	149.4	25.0	29.6	15.5	C	-	64.6	-	-	
	T	159.0	150.0	25.0	29.9	15.9	A	-	61.1	-	-	
C	L	149.9	149.4	36.0	52.7	16.2	A	126.7	-	-	86.0	
	T	147.3	145.2	34.0	46.1	15.3	A	123.9†	-	-	-	
	L	154.9	147.9	28.0	35.2	15.6	C	-	68.5	-	68.9	
	T	154.4	152.1	30.0	34.8	15.7	A	-	71.1†	-	69.3	
		157.2	152.4	26.0	29.6	15.8	C	-	-	-	-	

* Duplex anneal 1350F - 4 hr. WQ plus 1225F - 2 hr. WQ and aged 900F - 96 hr. AC.

† Used for structural analysis.

a E: Edge
M: Mid-radius
C: Center

c From slow bend precracked Charpy samples using $KQ = \frac{W}{A} \times \frac{E}{2(1-\nu^2)}$

d Valid fracture toughness, see Appendix H.

e For nomenclature used see Appendix F.

b L: Longitudinal
T: Transverse

TABLE LXVII

ROOM TEMPERATURE TENSILE, PRECRACKED CHARPY TOUGHNESS AND FRACTURE TOUGHNESS PROPERTIES*
OF SIX INCH BILLET OF ALLOY #227 (7Mo-4Cr-2.5Al)

Location ^a	Direction ^b	Mechanical Properties									
		UTS (ksi)	YS (ksi)	E1 (%)	RA (%)	E (x10 ⁶ psi)	Break	K _Q ^c (ksi/in.) LR ^e SL ^e		K _{IC} ^d (ksi/in.) SR ^e SL ^e	
E	L	182.1	168.7	12.0	40.0	16.0	B	58.5	-	-	-
	T	171.3	159.3	12.0	39.5	15.3	C	66.1†	-	-	-
		171.0	162.1	5.0	13.5	15.9	C	-	45.9	-	-
M	L	175.1	164.5	3.0	5.8	16.4	A	-	42.5†	-	-
		171.0	155.7	14.0	36.8	15.9	B	85.6	-	-	-
	T	171.0	155.7	14.0	35.6	16.2	C	77.8	-	-	-
C	L	173.5	160.0	3.0	8.2	16.4	C	-	46.6	-	-
		169.3	154.8	2.0	8.6	16.0	A	-	48.1	-	-
	T	169.5	153.3	10.0	33.4	15.9	C	80.4	-	55.2	-
C	L	163.5	147.9	13.0	38.6	15.9	A	86.8†	-	-	-
		167.0	152.4	7.0	19.5	15.6	B	-	57.3	-	50.6
	T	166.0	151.0	7.0	15.7	15.9	C	-	41.8†	-	48.4

* Duplex annealed 1450F - 2 hr. WQ plus 1350F - 8 hr. WQ and aged 925F - 8 hr. AC.

† Used for structural analysis.

^a E: Edge

M: Mid-radius

C: Center

^b L: Longitudinal

T: Transverse

^c From slow bend precracked Charpy samples using $K_Q = \frac{W}{A} \times \frac{E}{2(1-\nu^2)}$

^d Valid fracture toughness, see Appendix H.

^e For nomenclature used see Appendix F.

TABLE LXVIII

ROOM TEMPERATURE TENSILE PRECRACKED CHARPY TOUGHNESS AND FRACTURE TOUGHNESS PROPERTIES*
OF SIX INCH BILLET OF ALLOY #253 (10Mo-8V-2.5Al)

Location ^a	Direction ^b	Mechanical Properties							K _{IC} ^d (ksi/in.) SR ^e
		UTS (ksi)	YS (ksi)	E1 (%)	RA (%)	E (x10 ⁶ psi)	Break	K _{QC} ^c (ksi/in.) LR ^e SLE	
E	L	157.6	152.4	16.0	51.9	15.8	B	143.8	-
		150.9	147.9	14.0	48.9	15.9	C	129.7†	-
	T	153.4	145.8	10.0	15.7	15.3	B	-	89.1
		154.7	147.9	10.0	19.9	15.0	C	-	72.6†
M	L	143.9	143.1	17.0	63.2	15.9	C	123.3	-
		148.4	147.0	17.0	54.3	16.3	C	123.0	-
	T	156.7	145.8	8.0	19.9	15.3	A	-	71.5
		154.9	144.9	8.0	20.0	15.8	A	-	83.4
C	L	148.4	143.4	13.0	53.3	15.6	C	116.7†	-
		146.1	141.9	15.0	49.9	15.1	C	128.0	-
	T	155.8	147.3	8.0	16.8	15.6	B	-	80.0
		153.6	144.7	8.0	22.3	15.0	C	-	71.8†
		157.9	147.9	8.0	18.5	15.5	A	-	-

* Duplex annealed 1350F - 4 hr. WQ plus 1225F - 2 hr. WQ and aged 900F - 96 hr. AC.

† Used for structural analysis.

^a E: Edge
M: Mid-radius
C: Center
See Figure

^b L: Longitudinal
T: Transverse

^c From slow bend precracked Charpy samples using
$$K_Q = \frac{W}{A} \times \frac{E}{2(1-\nu^2)}$$

^d Valid fracture toughness, see Appendix H.
^e For nomenclature used see Appendix F.

TABLE LXIX

**ROOM AND ELEVATED TEMPERATURE TENSILE PROPERTIES
Alloy 334(10Mo-6Cr-2.5Al), Six Inch Billet***

<u>Temperature</u>	<u>Billet^a Location</u>	<u>Direction^b</u>	<u>UTS (ksi)</u>	<u>YS (ksi)</u>	<u>E1 (%)</u>	<u>RA (%)</u>	<u>E (x10⁶ psi)</u>	<u>Break</u>	
74F	E	L	157.9	153.9	36.0	49.5	16.0	B	
			158.4	154.8	34.0	56.5	16.7	C	
		T	158.9	151.5	10.0	22.3	15.4	A	
	155.2		148.8	20.0	24.3	15.6	C		
	M	L	150.9	150.6	32.0	45.3	15.9	B	
			148.9	144.9	34.0	54.3	16.5	B	
		T	157.7	149.4	25.0	29.6	15.5	C	
			159.0	150.0	25.0	29.9	15.9	A	
	C	L	149.9	149.4	36.0	52.7	16.2	A	
			147.3	145.2	34.0	46.1	15.3	A	
		T	154.9	147.9	28.0	35.2	15.6	C	
			154.4	152.1	30.0	34.8	15.7	A	
157.2			152.4	26.0	29.6	15.8	C		
400F	E	L	-	-	-	-	-	-	
		T	134.7	125.3	8.0	27.1	15.5	B	
	M	L	127.3	120.2	18.0	59.7	15.6	B	
		T	133.3	124.4	15.0	47.6	15.3	B	
	C	L	129.7	120.7	20.0	62.3	15.6	B	
			128.7	119.9	14.0	38.3	15.3	C	
		T	128.9	122.6	16.0	52.3	15.0	C	
	800F	E	L	119.7	106.2	20.0	69.4	13.7	C
				120.7	107.4	11.0	31.0	13.9	B
T			111.5	100.2	8.0	28.4	13.3	C	
M		L	118.0	105.4	23.0	73.2	13.5	B	
			114.8	103.0	9.0	31.3	13.0	A	
		T	118.1	104.8	13.0	36.2	13.5	A	
C		L	115.3	103.3	20.0	73.6	13.7	A	
			115.5	103.8	11.0	40.4	13.2	B	
		T	114.9	103.5	13.0	46.5	13.7	B	

* Duplex anneal 1350F - 4 hr. WQ plus 1225F - 2 hr. WQ and aged 900F - 96 hr. AC.

^a E: Edge
M: Mid-radius
C: Center

^b L: Longitudinal
T: Transverse

TABLE LXX

ROOM AND ELEVATED TEMPERATURE TENSILE PROPERTIES
Alloy 227 (7Mo-4Cr-2.5Al), Six Inch Billet*

<u>Temperature</u>	<u>Billet^a</u> <u>Location</u>	<u>Direction^b</u>	<u>UTS</u> <u>(ksi)</u>	<u>YS</u> <u>(ksi)</u>	<u>E1</u> <u>(%)</u>	<u>RA</u> <u>(%)</u>	<u>E</u> <u>(x10⁶ psi)</u>	<u>Break</u>	
70F	E	L	182.1	168.7	12.0	40.0	16.0	B	
			171.3	159.3	12.0	39.5	15.3	C	
		T	171.0	162.1	5.0	13.5	15.9	C	
			175.1	164.5	3.0	5.8	16.4	A	
	M	L	171.0	155.7	14.0	36.8	15.9	B	
			171.0	155.7	14.0	35.6	16.2	C	
		T	173.5	160.0	3.0	8.2	16.4	C	
			169.3	154.8	2.0	8.6	16.0	A	
	C	L	169.5	153.3	10.0	33.4	15.9	C	
			163.5	147.9	13.0	38.6	15.9	A	
		T	167.0	152.4	7.0	19.5	15.6	B	
			166.0	151.0	7.0	15.7	15.9	C	
400F	E	L	-	-	-	-	-	-	
			145.7	120.7	12.0	38.6	15.7	B	
	M	L	141.6	114.1	13.0	52.7	15.2	C	
			143.1	115.9	8.0	29.6	15.1	C	
	C	L	136.1	107.0	18.0	69.1	14.9	C	
			138.0	110.7	11.0	30.4	15.1	C	
		T	132.8	109.5	14.0	52.7	14.6	C	
			142.9	116.4	10.0	40.1	15.1	B	
	800F	E	L	123.8	91.9	16.0	65.6	13.3	C
			T	126.9	91.3	8.0	19.0 [†]	13.9	B
				124.7	98.1	10.0	40.4	13.5	B
		M	L	125.8	90.5	20.0	73.6	13.4	B
T			123.6	88.5	10.0	26.7	13.0	C	
			123.6	90.9	8.0	43.8	13.8	B	
C		L	122.9	89.3	17.0	72.4	13.1	C	
		T	119.2	83.9	16.0	42.2	12.8	A	
			122.6	86.7	12.0	42.6	13.2	C	

* Duplex annealed 1450F - 2 hr. WQ + 1350F - 8 hr. WQ and aged 925F - 8 hr. AC.

† Double neck.

^a E: Edge
M: Mid-Radius
C: Center

^b L: Longitudinal
T: Transverse

TABLE LXXI

**ROOM AND ELEVATED TEMPERATURE TENSILE PROPERTIES
Alloy 253(10Mo-8V-2.5Al), Six Inch Billet***

<u>Temperature</u>	<u>Billet^a Location</u>	<u>Direction^b</u>	<u>UTS (ksi)</u>	<u>YS (ksi)</u>	<u>E1 (%)</u>	<u>RA (%)</u>	<u>E (x10⁸ psi)</u>	<u>Break</u>	
74F	E	L	157.6	152.4	16.0	51.9	15.8	B	
			150.9	147.9	14.0	48.9	15.9	C	
		T	153.4	145.8	10.0	15.7	15.3	B	
			154.7	147.9	10.0	19.9	15.0	C	
	M	L	143.9	143.1	17.0	63.2	15.9	C	
			148.4	147.0	17.0	54.3	16.3	C	
		T	156.7	145.8	8.0	19.9	15.3	A	
			154.9	144.9	8.0	20.0	15.8	A	
	C	L	148.4	143.4	13.0	53.3	15.6	C	
			146.1	141.9	15.0	49.9	15.1	C	
		T	155.8	147.3	8.0	16.8	15.6	B	
			153.6	144.6	8.0	22.3	15.0	C	
			157.9	147.9	8.0	18.5	15.5	A	
400F	E	L	-	-	-	-	-	-	
		T	122.0	113.6	8.0	33.9	15.3	B	
	M	L	121.5	117.3	18.0	64.4	15.0	B	
		T	131.2	118.3	15.0	45.3	15.0	C	
	C	L	118.1	111.0	14.0	69.1	15.5	C	
		T	128.2	115.2	12.0	36.2	15.0	B	
			129.2	117.3	13.0	48.3	15.1	B	
	800F	E	L	106.4	93.1	18.0	64.0	13.4	B
			T	109.5	96.0	10.0	44.1	13.3	C
			109.2	96.6	14.0	52.7	14.0	B	
M		L	106.2	93.8	19.0	69.5	13.2	B	
		T	111.2	96.0	14.0	44.1	14.1	C	
			111.3	97.3	15.0	52.1	13.2	A	
C		L	106.2	93.8	15.0	61.1	13.8	A	
		T	113.3	98.1	11.0	43.5	13.9	C	
			110.2	95.6	12.0	46.7	13.4	B	

* Duplex annealed 1350F - 4 hr. WQ + 1225F - 2 hr. WQ and aged 900F - 96 hr. AC.

^a E: Edge
M: Mid-Radius
C: Center

^b L: Longitudinal
T: Transverse

TABLE LXXII

**ROOM TEMPERATURE TENSILE AND PRECRACKED CHARPY
TOUGHNESS PROPERTIES* OF 6" BILLET OF
ALLOY #334(10Mo-6Cr-2.5Al)**

Location ^a	Direction ^b	Mechanical Properties						K _{Qc} ^c	
		Tensile					Break	LRd	SLd
		UTS (ksi)	YS (ksi)	EI (%)	RA (%)	E (x10 ⁶ psi)			
E	L	151.6	148.8	36.0	46.5	17.5	B	--	--
	T	154.4	149.7	21.0	30.0	15.6	C	--	--
M	L	138.6	136.1	34.0	53.4	15.9	B	156.1	--
	T	151.6	150.0	24.0	28.4	16.4	B	143.4	--
C	L	148.3	144.3	32.0	37.7	16.4	B	--	--
		147.1	144.6	25.0	33.1	15.6	B	--	78.2
	T	151.8	147.6	28.0	35.0	15.9	A	--	72.2

* Duplex annealed 1350F - 4 hr WQ plus 1225F - 2 hr WQ and aged 1000F - 96 hr AC.

^a E: Edge
M: Mid-radius
C: Center

^b L: Longitudinal
T: Transverse

^c From slow bend precracked Charpy samples using $K_Q = \frac{W}{A} \times \frac{E}{2(1-\nu^2)}$

^d For nomenclature used see Appendix F.

TABLE LXXIII

ROOM TEMPERATURE TENSILE AND PRECRACKED CHARPY
TOUGHNESS PROPERTIES* OF 6" BILLET OF
ALLOY #227 (7Mo-4Cr-2.5Al)

Location ^a	Direction ^b	Mechanical Properties						K _Q ^c	
		Tensile						LR ^d	SL ^d
		UTS (ksi)	YS (ksi)	El (%)	RA (%)	E (x10 ⁶ psi)	Break		
E	L	164.0	156.9	14.0	38.0	16.1	A	--	--
	T	164.5	153.9	4.0	9.7	16.5	A	--	--
M	L	162.0	151.2	14.0	39.8	16.0	A	102.2	--
	T	158.8	149.1	-	-	15.9	OGM	99.6	55.3
C	L	158.5	147.6	16.0	46.5	15.8	C	--	--
	T	155.3	144.9	8.0	29.0	15.9	C	--	62.2
		158.3	148.8	10.0	30.7	16.0	A	--	60.1

* Duplex annealed 1450F - 2 hr WQ plus 1350F - 8 hr WQ and aged 1000F - 8 hr AC

^a E: Edge
M: Mid-radius
C: Center

^b L: Longitudinal
T: Transverse

^c From slow bend precracked Charpy samples using $K_Q = \frac{W}{A} \times \frac{E}{2(1-\nu^2)}$

^d For nomenclature used see Appendix F.

TABLE LXXIV

**ROOM TEMPERATURE TENSILE AND PRECRACKPED CHARPY
TOUGHNESS PROPERTIES* OF 6" BILLET OF
ALLOY #253(10Mo-8V-2.5Al)**

Location ^a	Direction ^b	Mechanical Properties						K _Q ^c	
		Tensile					Break	(ksi/in)	
		UTS (ksi)	YS (ksi)	E1 (%)	RA (%)	E (x10 ⁶ psi)		LR ^d	SL ^d
E	L	142.6	137.9	16.0	47.7	15.6	C	--	--
	T	144.9	140.3	18.0	60.4	15.8	C	--	--
M	L	143.4	137.3	10.0	27.0	14.9	B	--	--
	T	149.8	147.6	19.0	48.4	15.5	C	145.9	--
C	L	148.9	139.7	11.0	29.6	15.1	C	140.0	--
	T	139.8	135.8	16.0	47.7	14.9	C	--	78.1
C	L	144.9	139.7	11.0	27.6	15.0	B	--	73.8
	T	145.4	140.6	10.0	27.6	15.0	C	--	83.5
								--	78.9

* Duplex annealed 1350F - 4 hr WQ plus 1225F - 2 hr WQ and aged 1000F - 96 hr AC.

^a E: Edge
M: Mid-radius
C: Center

^b L: Longitudinal
T: Transverse

^c From slow bend precracked Charpy samples using $K_Q = \frac{W}{A} \times \frac{E}{2(1-\nu^2)}$

^d For nomenclature used see Appendix F.

TABLE LXXV

ROOM TEMPERATURE TENSION-TENSION FATIGUE DATA

(Six Inch Diameter Billet, Transverse
Specimens Center Location)

Unnotched, R = + 0.1

Maximum Stress ksi	Cycles to Failure, x10 ³		
	Alloy 334 ^a	Alloy 227 ^b	Alloy 253 ^c
120	-	217	-
115	-	1,337	-
110	-	2,542*	-
110	-	2,640*	48
105	-	-	44
105	-	-	44
100	2,737	2,614*	2,524*
100	1,915	2,676*	6,829*
95	618	-	3,073*
95	2,653*	-	-
90	2,448	-	-
90	2,544*	-	-

Notched, K_t = 3.0, R = + 0.1

52		510	
50	35	2,568*	
48		-	44
47	101	6,891*	-
45	2,603*	-	-
43			125
40			2,614*

Tensile Properties, Transverse Specimens
Center/Mid-Radius Positions

UTS, ksi	156	167	156
YS, ksi	151	152	147
% Elongation	28	7	8
% RA	33	18	19

^a (10Mo-6Cr-2.5Al) - Duplex annealed 1350F - 4 hr, WQ + 1225F - 2 hr, WQ, aged 900F - 96 hr.

^b (7Mo-4Cr-2.5Al) - Duplex annealed 1450F - 2 hr, WQ + 1350F - 8 hr, WQ, aged 925F - 8 hr.

^c (10Mo-8V-2.5Al) - Duplex annealed 1350F - 4 hr, WQ + 1225F - 2 hr, WQ, aged 900F - 96 hr.

* Test discontinued, no failure.

TABLE LXXVI

CREEP AND CREEP STABILITY FROM CENTER LOCATION 6 INCH BILLET
TENSILE SAMPLES - ALLOY 334(10Mo-6Cr-2.5Al), 227(7Mo-4Cr-2.5Al) AND 253(10Mo-8V-2.5Al)

Alloy	Creep Exposure		Total Creep Strain (%)	Direction	Tensile Properties					
	Temp. (F)	Time (hr)			Stress (ksi)	UTS (ksi)	YS (ksi)	E1 (%)	RA (%)	E (x10 ⁶ psi)
334 a	No exposure		-	L	148.6	147.3	35.0	49.4	15.8	B
	600	100	0.249		150.9	149.4	18.0	46.5	17.1	
227 b	No exposure		0.920	T	155.5	150.8	28.0	33.2	15.7	B
	600	100	0.440P		151.6	145.8	8.0	29.7	16.3	
	No exposure		-	L	166.5	150.6	11.5	36.0	15.9	A
	600	100	0.984		160.3	155.5	14.0	46.8	14.2	
253 a	No exposure		0.424	T	166.5	151.7	7.0	16.6	15.8	A
	600	100	0.640P		169.4	165.8	5.0	10.1	15.4	
	No exposure		-	L	173.5	164.5	3.0	11.7	15.5	C
	600	100	0.298		147.3	142.7	14.0	51.6	15.4	
	No exposure		0.040	T	150.9	147.9	15.0	49.9	16.0	B
	600	100	1.30P		150.8	146.7	8.0	19.2	15.3	
	No exposure		-		158.7	153.9	6.0	16.5	14.8	B
	600	100			155.8	151.5	9.0	17.6	15.9	

a Duplex annealed 1350F-4 hr WQ + 1225F - 2 hr WQ, aged 900F - 96 hr AC.

b Duplex annealed 1450F - 2 hr WQ + 1350F - 8 hr WQ, aged 925F - 8 hr AC.

c In air, samples indicated P after creep strain pickled prior to tensile testing, other samples tested with skin on.

d No exposure sample results are average values taken from Tables LXVI, LXVII and LXVIII.

TABLE LXXVII

ALLOY #334 (10Mo-6Cr-2.5Al) PHASE III MECHANICAL PROPERTY DATA,*
Half Inch Plate

Annealing ^a		Aging ^b		Direction ^c	Mechanical Properties							
Temp. (F)	Time (hr)	Temp. (F)	Time (hr)		UTS (ksi)	YS (ksi)	E1 (%)	RA (%)	E (x10 ⁶ psi)	Break	RW	K _{Qd} (ksi/in.)
1350	8	950	96	L	178.1	175.4	8.0	19.9	15.2	B	53.6	-
					181.4	178.9	8.0	18.2	15.3	A	49.2	-
					197.4	191.8	2.0	3.2	15.6	A	-	45.1
					198.9	190.9	2.0	5.6	16.6	C	-	44.4
1025	96	L	160.6	160.5	14.0	29.2	14.8	B	65.1	-		
			159.0	157.5	12.0	42.2	16.1	C	64.7	-		
			180.4	173.4	6.0	9.4	17.6	A	-	60.0†		
			176.9	168.0	4.0	7.8	16.8	B	-	60.1		

* Material forged to 10.5 inch RCS then rolled from 3 to 1/2 inch plate from 1500F (four re-heats: 2 inch, 1-3/8 inch, 0.9 inch, 0.7 inch), finished at ~1225F.

† Used for structural analysis.

^a Followed by WQ.

^b Followed by AC.

^c L - longitudinal
T - transverse

^d Calculated from slow bend precracked Charpy samples using $K_Q^2 = \frac{W}{A} \times \frac{E}{2(1-\nu^2)}$

TABLE LXXVIII

ALLOY #227 (7Mo-4Cr-2.5Al) PHASE III MECHANICAL PROPERTY DATA, *
Half Inch Plate

Annealing ^a Treatment		Aging ^b Treatment		Direction ^c	Mechanical Properties							
Temp. (F)	Time (hr)	Temp. (F)	Time (hr)		UTS (ksi)	YS (ksi)	E1 (%)	RA (%)	E (x10 ⁶ psi)	Break	RW	K _Q ^d (ksi/in.) WR
1450	8	1025	8	L	170.3	164.4	12.0	62.3	14.8	C	45.3	-
				T	171.4	163.2	14.0	31.9	15.3	B	50.4	-
					184.7	176.2	13.0	32.3	15.9	B	-	42.7
					184.9	179.8	9.0	31.3	15.9	C	-	42.4†
		1125	8	L	147.1	143.1	19.0	51.6	16.3	A	98.5	-
				T	145.3	142.8	17.0	48.5	15.0	A	94.4	-
					155.9	150.0	12.0	44.2	16.8	B	-	83.0
					154.6	149.7	18.0	35.7	17.0	C	-	83.2

* Material forged to 10.5 inch RCS then rolled from 2-3/4 to 1/2 inch plate from 1500F (two re-heats 1-3/8 and 0.9 inch), finished at ~1250F.

† Used for structural analysis.

^a Followed by WQ.

^b Followed by AC.

^c L - longitudinal
T - transverse

^d Calculated from slow bend precracked Charpy samples using $K_Q^2 = \frac{W}{A} \times \frac{E}{2(1-\nu^2)}$

TABLE LXXIX

ALLOY #253 (10Mo-8V-2.5Al) PHASE III MECHANICAL PROPERTY DATA,*
Half Inch Plate

Annealing ^a Treatment		Aging ^b Treatment		Direction ^c	Mechanical Properties							K _Q (ksi/in.)	
Temp. (F)	Time (hr)	Temp. (F)	Time (hr)		UTS (ksi)	YS (ksi)	EI (%)	RA (%)	E (x10 ⁶ psi)	Break	RW	WR	
1350	8	950	96	L	180.1	170.8	6.0	7.4	14.6	A	47.5	-	
				T	176.2	168.4	4.0	5.4	15.1	B	50.4	-	
					190.1	184.1	5.0	10.5	15.3	B	-	47.0	
					187.4	179.6	7.0	18.5	14.4	B	-	46.2†	
		1025	96	L	160.1	156.6	4.0	6.6	14.7	B	63.8	-	
				T	155.9	153.0	4.0	4.4	14.3	B	59.9	-	
					166.7	160.6	8.0	14.3	14.5	B	-	62.2	
					169.6	164.1	6.0	13.0	15.8	C	-	58.8	

* Material forged to 10.5" RCS then rolled from 3-3/8" to 1/2" plate from 1500F (two reheats, 1-3/4" and 1-1/8") finished at ~1250F.

† Used for structural analysis.

^a Followed by WQ.

^b Followed by AC.

^c L - longitudinal
T - transverse

^d Calculated from slow bend precracked Charpy samples using $K_Q = \frac{W}{A} \times \frac{E}{2(1-\nu^2)}$

TABLE LXXIX

ALLOY #253 (10Mo-8V-2.5Al) PHASE III MECHANICAL PROPERTY DATA,*
Half Inch Plate

Annealing ^a Treatment Temp. (F)	Aging ^b Treatment Temp. (F)	Time (hr)	Direction ^c	Mechanical Properties					K _{Qd} (ksi/in.)	
				UTS (ksi)	YS (ksi)	El (%)	RA (%)	E (x10 ⁶ psi)		Break
1350	950	96	L	180.1	170.8	6.0	7.4	14.6	A	47.5
			T	176.2	168.4	4.0	5.4	15.1	B	50.4
	1025	96	L	160.1	156.6	4.0	6.6	14.7	B	63.8
			T	166.7	160.6	8.0	14.3	14.5	B	62.2
				187.4	179.6	7.0	18.5	14.4	B	47.0
				169.6	164.1	6.0	13.0	15.8	C	46.2 [†]

* Material forged to 10.5" RCS then rolled from 3-3/8" to 1/2" plate from 1500F (two reheats, 1-3/4" and 1-1/8") finished at ~1250F.

† Used for structural analysis.

^a Followed by WQ.

^b Followed by AC.

^c L - longitudinal
T - transverse

^d Calculated from slow bend precracked Charpy samples using $K_Q^2 = \frac{W}{A} \times \frac{E}{2(1-\nu^2)}$

TABLE LXXX

BETA MATRIX TEXTURE STUDY FOR
PHASE III BILLET AND PLATE

<u>Alloy</u>	<u>Product Form a</u>	<u>Heat Treatment^b</u>		<u>Sample Orientation^c</u>	<u>Poles Investigated^d</u>			
		<u>I</u>	<u>II</u>		<u>(110)</u>	<u>(200)</u>	<u>(211)</u>	
		<u>Temp. (F)</u>	<u>Time (hr)</u>	<u>Temp. (F)</u>	<u>Time (hr)</u>			
334	B	1350	4	1225	2	X	X	X
						X	X	-
	P	1350	8	-	-	X	X	-
227	B	1450	2	1350	8	X	X	-

^a B - Billet
P - Plate

^b Both anneals followed by WQ.

^c See Appendix F for nomenclature used. Letters indicate plane of material analyzed.

^d 45° one quadrant figures.

TABLE LXXXI

**MECHANICAL PROPERTIES AND DUCTILITY DIRECTIONALITY
OF ALLOYS 334(10Mo-6Cr-2.5Al) and 227(7Mo-4Cr-2.5Al)
BILLET AS DUPLEX ANNEALED***

Alloy	Direction	Mechanical Properties						Break	Average RA(%)	Ductility Directionality Reduction in Diameter ^a (inch x 10 ⁻³)				
		UTS (ksi)	YS (ksi)	E1 (%)	RA (%)	E (x10 ⁶ psi)	L			S ₁	S ₂	L	S ₁	S ₂
334	L	135.7	128.7	22.0	53.5	13.9	B		077	078				
		135.3	129.3	22.0	54.5	14.8	C		090	070				
		135.5	129.0	22.0	45.0	16.2	A	52.2	052	067				
	T	137.3	129.3	24.0	55.7	14.9	A		083	078		076	073	
		137.8	132.8	18.0	48.3	14.5	B		073	060				
		135.5	131.0	16.0	38.7	13.6	B		054	054				
227	L	127.3	126.3	11.0	46.7	13.0	A	44.4	070	057				
		138.8	135.3	16.0	43.7	14.4	A†		088	060		071	058	
		125.5	123.2	22.0	55.7	12.7	B			109	065			
	T	123.5	121.1	22.0	56.1	14.7	B			083	075			
		123.5	120.2	20.0	61.1	13.9	B	57.9		095	101			
		125.2	123.2	17.0	58.7	13.4	B			075	099		091	085
		128.0	124.1	12.0	47.9	14.5	B		082	048				
		129.0	125.5	12.0	53.2	14.5	B†		087	064				
		127.8	123.2	14.0	49.7	13.1	A	49.1	078	060				
		127.3	123.2	20.0	45.5	14.2	A		066	052		078	056	

* Alloy #334: 1350F - 4 hr WQ plus 1225F - 2 hr WQ.
Alloy #227: 1450F - 2 hr WQ plus 1350F - 8 hr WQ.

† Used for structural study.

^a L - longitudinal axis of billet.

S₁, S₂ - transverse axis of billet

Values represent reduction in diameter of original 0.250" round in the directions specified.

TABLE LXXXII

PHASE III STRUCTURAL WORK:
SAMPLE GROUPS EVALUATED

<u>Group</u>		<u>Figures</u>
1	Single/double aged (pre-age)	94-102
2	"Optimum" processing 10.5" RCS-6" billet	103-128
3	Beta recrystallized	129-138
4	Beta processed	139-147
5	High-low solution anneal	148-154
6	Low-high solution anneal	155-162
7	Six inch billet	163-204
8	Half inch plate	205-213
9	Tensile samples	214-221
10	Billet as duplex solution annealed	222-227

TABLE LXXXIII
MECHANICAL PROPERTIES AND CORRESPONDING MICROSTRUCTURAL FEATURES

Gr. ^a	Spec. Code ^b	Dirn.	Mechanical Properties			Str. α ^c	Prim. α Aspect Ratio ^d	Sub-Grn. ^c	Grain Bdry. α ^a	Fret. Path ^e	SEM Dimple Size (μm) ^g		Particle Spacing (μm)		Crack Path Dimple Size (μm) ^g	
			YS (ksi)	RA (%)	K _{IC} (ksi/in.)						Small	Large	Fine	Prim.	Small	Large
1	4C1Y1 C	L	186	23	86 (LR)	P	6	-	SC	3	?	10	-	-	-	-
	4C1Z1 C	L	190	17	69 (LR)	P	6	-	SC	3	1.5	10	-	-	-	-
	3C3Y1 C	L	157	33	104 (LR)	P	5	-	-	1	1.5	7	-	-	-	-
	3C3Z1 C	L	170	22	75 (LR)	P	6	-	-	2	2	10	-	-	-	-
2	4SLR10 C	L	183	15	84 (LR)	P	6	-	SC	2	2	8	0.2	4	2	12
	4SR2 C	T	185	4	57 (SR)	P	6	-	SC	3	1.5	10	0.2	2	3	15
	7SLR11 C	L	174	24	59 (LR)	P	6	F	NP	1	1.5	20	0.2	7	3	10
	7SLR3 C	T	171	12	51 (SR)	P	6	F	NP	2	1.5	20	0.2	6	3	15
	7SLR9 C	L	183	28	78 (LR)	P	3	F	SC	2	-	-	0.2	5	4	15
	7SR1 C	T	183	6	41 (SR)	P	3	F?	SC	3	-	-	0.2	4	3	10
	3SLR10 C	L	172	31	78 (LR)	P	6	NP?	SC	2	2	8	0.2	1.5	3	15
	3SR2 C	T	167	13	48 (SR)	P	6	NP?	SC	3	2	10	0.2	2	3	15
3	4MSL8 C	L	167	14	58 (LR)	-	-	-	-	-	-	-	-	-	-	-
	T	178	6	43 (SL)	NP	6	NP	C	3.5	3	20	0.2	3	3	6	
	7MSL4 C	L	180	5	57 (LR)	-	-	-	-	-	-	-	-	-	-	-
T	188	6	41 (SL)	NP	6	NP	C	3.5	2	15	0.2	10	3	10		
4	4SL2 C	L	177	13	99 (LR)	-	-	-	-	-	-	-	-	-	-	-
	T	182	9	60 (SL)	P	6	F?	SC	3	1.5	12	0.2	2	3	10	
	7SL2 C	L	183	13	53 (LR)	-	-	-	-	-	-	-	-	-	-	-
	T	184	10	57 (SL)	P	6	NP?	SC	2	1.5	10	0.2	6	3	15	
5	4SR12 C	L	147	39	158 (LR)	-	-	-	-	-	-	-	-	-	-	-
	T	149	23	83 (SR)	P	3	NP?	SC	3	-	-	0.4	1.5	3	15	
	7SR22 C	L	146	58	179 (LR)	-	-	-	-	-	-	-	-	-	-	-
	T	146	44	86 (SR)	P	3	NP?	SC/G	3	-	-	0.5	3	3	15	
6	4SR16 C	L	167	31	95 (LR)	-	-	-	-	-	-	-	-	-	-	-
	T	170	6	60 (SR)	P	3	NP?	SC/G	3	3	15	0.4	4	4	10	
	7SR20 C	L	-	-	- (LR)	-	-	-	-	-	-	-	-	-	-	-
T	166	11	38 (SR)	P	2	F	SC/G	3	1.0	8	0.2	6	5	15		
7	4LRC2 C	L	147	50	126 (LR)	P	3	NP?	SC/G	3	2.0	15	0.5	1.5	3	10
	4SLC2 C	T	151	33	70 (SL)	P	2	NP?	SC/G	2	2.0	20	0.5	1.5	3	10
	4SLC4 C	L	144	37	- (LR)	-	-	-	-	-	-	-	-	-	-	-
	T	146	34	75 (SL)	P	2	NP?	SC/G	2	1.5	10	0.5	2	2.5	10	
	4LRE2 C	L	155	53	134 (LR)	P	6	NP?	SC	3	-	-	0.4	1.5	3	12
	4SLR2 C	T	150	23	59 (SL)	P	3	NP?	SC	2	-	-	0.4	1.5	2.5	10
	7LRC1 C	L	151	36	84 (LR)	P	5	NP	SC/G	2	3	8	0.3	3	2.5	8
	7SLC1 C	T	152	18	50 (SL)	P	5	NP?	SC/G	2	3	12	0.2	2	3	12
	7LRE2 C	L	164	40	62 (LR)	P	6	NP?	SC/G	3	-	-	0.3	3	3	10
	7SLE2 C	T	163	10	44 (SL)	P	5	F?	SC/G	3	-	-	0.2	2.5	3	8
	3LRC1 C	L	143	52	123 (LR)	P	5	F?	SC/G	3	2	8	0.3	1.5	2	12
	3SLC2 C	T	147	19	76 (SL)	P	6	NP?	SC/G	2	2	15	0.4	1.5	2	10
3LRE2 C	L	150	51	137 (LR)	P	5	NP?	SC/G	3	-	-	0.4	1.0	2	8	
3SLE2 C	T	147	18	81 (SL)	P	6	NP?	SC/G	2	-	-	0.4	1.0	2	10	
8	4WRH1 C	L	159	36	65 (WR)	-	-	-	-	-	-	-	-	-	-	-
	T	171	9	60 (WR)	P	3	NP?	SC/G	2	-	-	0.3	6	3	15	
	7WRL2 C	L	164	47	48 (WR)	-	-	-	-	-	-	-	-	-	-	-
	T	178	32	43 (WR)	P/NP	2	F	SC/G	1	-	-	0.3	6	4	10	
3WRL2 C	L	170	6	49 (WR)	-	-	-	-	-	-	-	-	-	-	-	
T	182	15	47 (WR)	P	4	F?	SC/L	2	-	-	0.3	5	4	8		
9	4TC2 T	L	147	50	-	-	-	-	-	-	-	-	-	-	-	-
	T	151	33	-	P	3	NP?	SC/G	{ 2 (L) 3 (R)	2	12	-	2	4	10	
	7ET3 T	L	174	24	-	-	-	-	-	-	-	-	-	-	-	-
	T	171	12	-	P	6	F	NP	{ 2 (L) 2 (R)	1.5	20?	-	6	4	10	
7MT7 T	L	180	5	-	-	-	-	-	-	-	-	-	-	-	-	
T	188	6	-	NP	6	NP	C	{ 3.5(L) 3.5(R)	2	8	-	-	-	-		
10	4T4 T	L	129	52	-	-	-	-	-	-	-	-	1.5	3	12	
	T	131	44	-	P	3	NP?	SC/G	{ 3 (S) 3 (L)	-	-	-	1.5	3	10	
	L	122	58	-	-	-	-	-	-	-	-	-	2	3	8	
	T	124	49	-	P	5	NP?	SC/G	{ 3 (S) 3 (L)	-	-	-	3	2	10	

^aSee Table LXXXII

^bC - Charpy; T - Tensile

^cP - Present; NP - Not Present

^dApproximate average value

^eC - Continuous grain boundary alpha; SC - Semi-continuous grain boundary alpha

SC/G - Semi-continuous but mainly of a globular type; NP - Not Present

^f1 - Predominantly Transgranular; 4 - Predominantly Intergranular/Along Stringer Alpha Particles (crack branching)

^gLarge dimple size was made up of groups of smaller dimples

TABLE LXXXIV

MECHANICAL PROPERTIES OF SAMPLES USED FOR STRUCTURAL ANALYSIS
AFTER A DUPLEX (LOW-HIGH)* AGING TREATMENT

Alloy No.	Sample Code	Solution Treat		Treatment		Age		Properties ^a		
		Temp. (F)	Time (hr)	Temp. (F)	Time (hr)	Temp. (F)	Time (hr)	YS	RA	K _Q ^b
334	4C1Y1	1350	4	-	-	900	96	186	23	86
	4C1Z1	1350	4	750	8	925	8	190	17	69
253	3C3Y1	1275	4	-	-	950	96	157	33	104
	3C3Z1	1275	4	750	8	900	8	170	22	75

* Low to produce phase separation of solute lean bcc "zones," high to transform these regions to a fine dispersion of α -phase.

^a Average of two tests in each case.

^b From slow bend precracked Charpy samples using $K_Q^E = \frac{W}{A} \times \frac{E}{2(1-\nu^2)}$.

TABLE LXXXV

FORGEABILITY OF THE PHASE III ALLOYS

<u>Alloy No.</u>	<u>Composition (bal. Ti)</u>	<u>Bloom Sample Location</u>	<u>Average Compressive Flow Stress, x 10³ psi^{a, b}</u>		
			<u>1450F</u>	<u>1550F</u>	<u>1650F</u>
334	10Mo-6Cr-2.5Al	Edge Center	95 87	85 76	- -
227	7Mo-4Cr-2.5Al	Edge Center	- -	61 64	55 54
253	10Mo-8V-2.5Al	Edge Center	76 74	68.5 68.5	- -
-	6Al-4V	-	92	75	70
beta III	11.5Mo-6Zr-4.5Sn	-	73	-	63

^a Compressive flow stress = $\frac{\text{Work}}{\text{Volume} \times L_N} \frac{(H_i)}{(H_f)}$

^b Strain rate approximately 275 sec⁻¹

TABLE LXXXVI

ENDURANCE LIMIT OF CONTRACT ALLOYS[@], AND COMPARISON
WITH OTHER POTENTIAL DEEP HARDENABLE TITANIUM ALLOYS

<u>Alloy</u>	<u>UTS (ksi)</u>	<u>Endurance Limit (ksi)</u>		<u>Endurance Limit/UTS (%)</u>	
		<u>Unnotched</u>	<u>Notched</u>	<u>Unnotched</u>	<u>Notched</u>
334	156	92	46	59	29.5
227	167	114	51	68	30.5
253	156	104	42	67	27
<hr/>					
Ti-6- 22-22S*	171	95	45	55	26
Ti-6Al- 2Sn-4Zr- 6Mo†	169/186	81	36	<48	<21

[@] Six inch diameter billet, transverse specimens center location, $R = +0.1$, K_t (notched) = 3.0, 2.5×10^6 cycles, values from Figures 230, 231 and 232.

* Two inch bar, longitudinal specimens mid-radius location, $R = +0.1$, K_t (notched) = 3.0, 10^7 cycles, Table XXXIII reference 27.

† Forgings, references 40 and 41.

TABLE LXXXVII

TOUGHNESS-DUCTILITY OF Ti-Mo-Cr-V-Al HALF INCH PLATE
ALLOYS[†] AT GOAL YIELD STRENGTH LEVEL[ⓐ]

Alloy No.	Composition (bal Ti)				K _Q ^a (ksi/in)		RA ^b (%)	
	Mo	Cr	V	Al	RW	WR	L	T
334	10	6	-	2.5	57.0	59.9	24.7	8.5
16*	8	4.5	-	2.5	55.0	62.5	24.5	20.0
227	7	4	-	2.5	42.5	55.0	46.7	25.1
253	10	-	8	2.5	48.0	55.2	4.7	15.0

[ⓐ] At a yield strength corresponding to YS/density of 1.0 x 10⁶ inches.

[†] Processed in a similar manner; i.e, low temperature processed, annealed at ~8 T - 75F for 8 hours.

* Data developed under NAVAIR contract N00019-73-C-0335, alloy composition derived on basis of Phase I and II results under present contract.

^a From Figures 234, 235, 236 and 237.

^b From Figures 238, 239, 240 and 241.

TABLE LXXXVIII

PREDICTED DUCTILITY DIRECTIONALITY BASED ON THE ANTICIPATED CRACK CHARACTERISTICS IN PLATE AND BILLET*

Product Form	Direction ^a		Crack Propagation	Crack Characteristics		Predicted Ductility
	Tensile Axis			Nucleation ^b	Growth ^c	
Billet	L	S ₁ or S ₂		D	L	High
	S ₂ S ₂	L S ₁		E D	L S	Moderate Low
Plate	R R	W T		E/D D	L L	Mod-High High
	W W	R T		E D	L S	Moderate Low

* See Figures 259 and 260 .

^a See Appendix F.

Billet L - longitudinal

S₁, S₂ - transverse

Plate R - rolling direction

W - width

T - thickness

^b D - Difficult nucleation } See text.
E - Easy nucleation

^c L - Large amount of plastic work during deformation.
S - Small amount of plastic work during deformation.

TABLE LXXXIX

TRANSVERSE MECHANICAL PROPERTIES OF CONTRACT ALLOYS
IN SIX INCH SECTION BILLET

Alloy No.	Composition (bal. Ti)	Center Six Inch Billet ^a				Predicted from Alloy Trend Line ^b				
		YS (ksi)	El (%)	RA (%)	K _{Ic} (ksi/in)	(K _{Ic} /YS) ^c (inches)	YS (ksi)	El (%)	RA (%)	K _{Ic} (ksi/in)
	Contract Goal ^c	-	-	-	-	-	12	18	60	0.095
334	10Mo-6Cr-2.5Al	150.8	28.0	33.2	69.1	0.210	171*	15	60	0.119
227	7Mo-4Cr-2.5Al	151.7	7.0	17.6	49.5	0.123	169*	3	46	0.074
253	10Mo-8V-2.5Al	146.6	8.0	19.2	80.0	0.300	171*	5	58	0.115

^a Actual values from center of six inch section, heat treated as specified in Tables LXVI (#334), LXVII (#227) and LXVIII (#253).

^b Values predicted at goal yield strength level from Figures 248, 251 and 254 (#334), 249, 252 and 255 (#227), and 250, 253 and 256 (#253).

^c Contract goal at a yield strength corresponding to YS/density of 1.0 x 10⁶ inches.

* Contract goal yield strength level (density normalized).

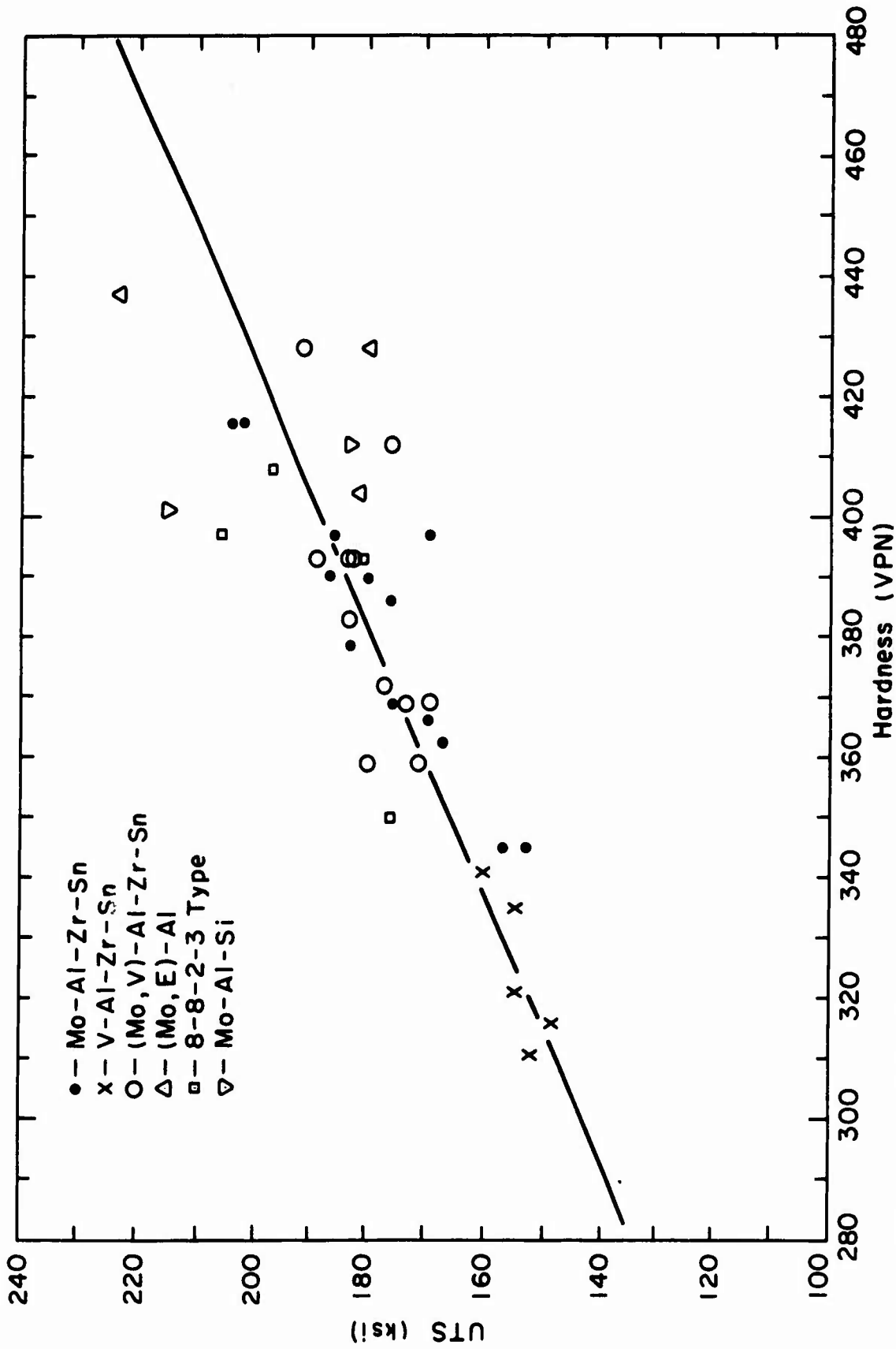

Fig. 1 - Relationship between hardness (VPN) and ultimate tensile strength (UTS) for the Phase I contract alloys. Best fit straight line was obtained by linear regression analysis.

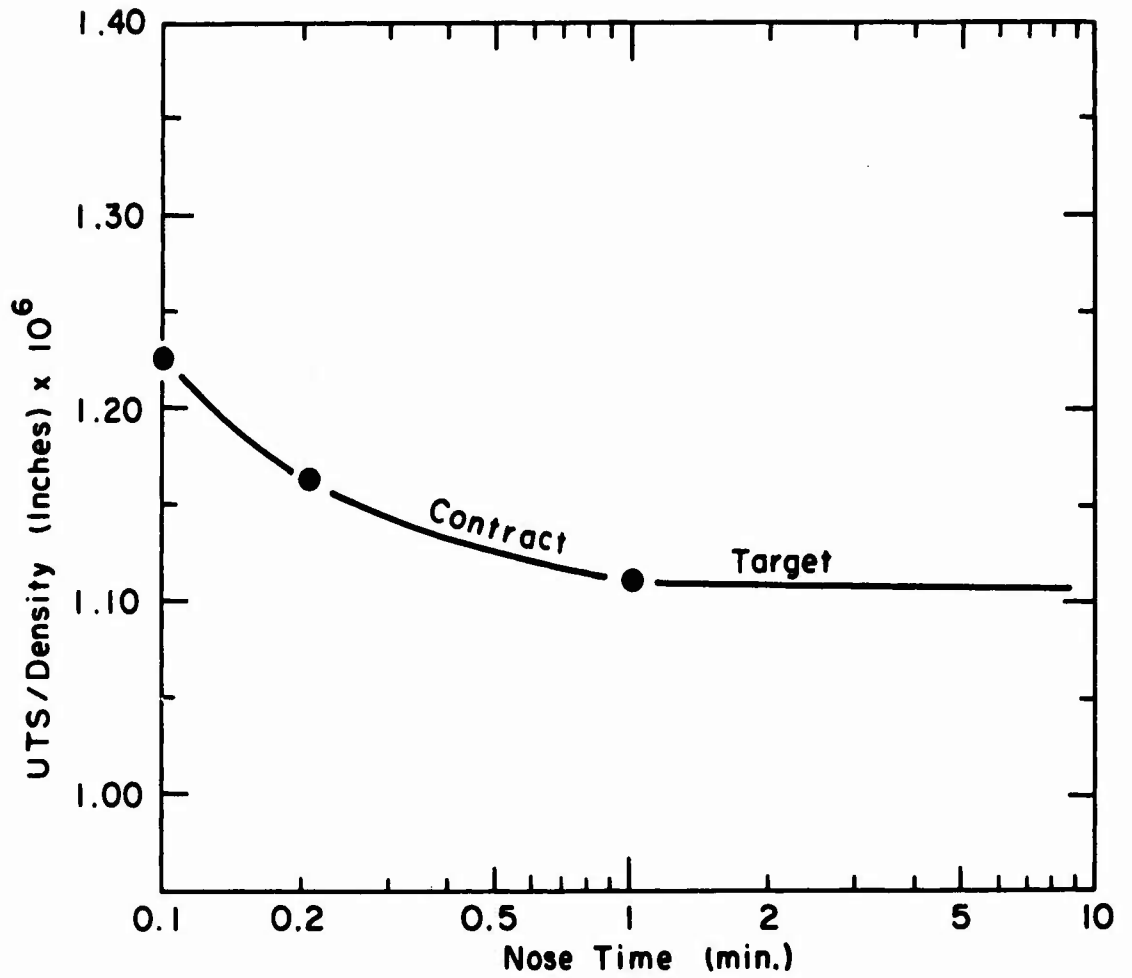

Fig. 2 - Necessary characteristics to meet contract strength goals derived from Table XII, and assuming a required hardness of 400 VPN and a density of 0.169 lbs. ins⁻³.

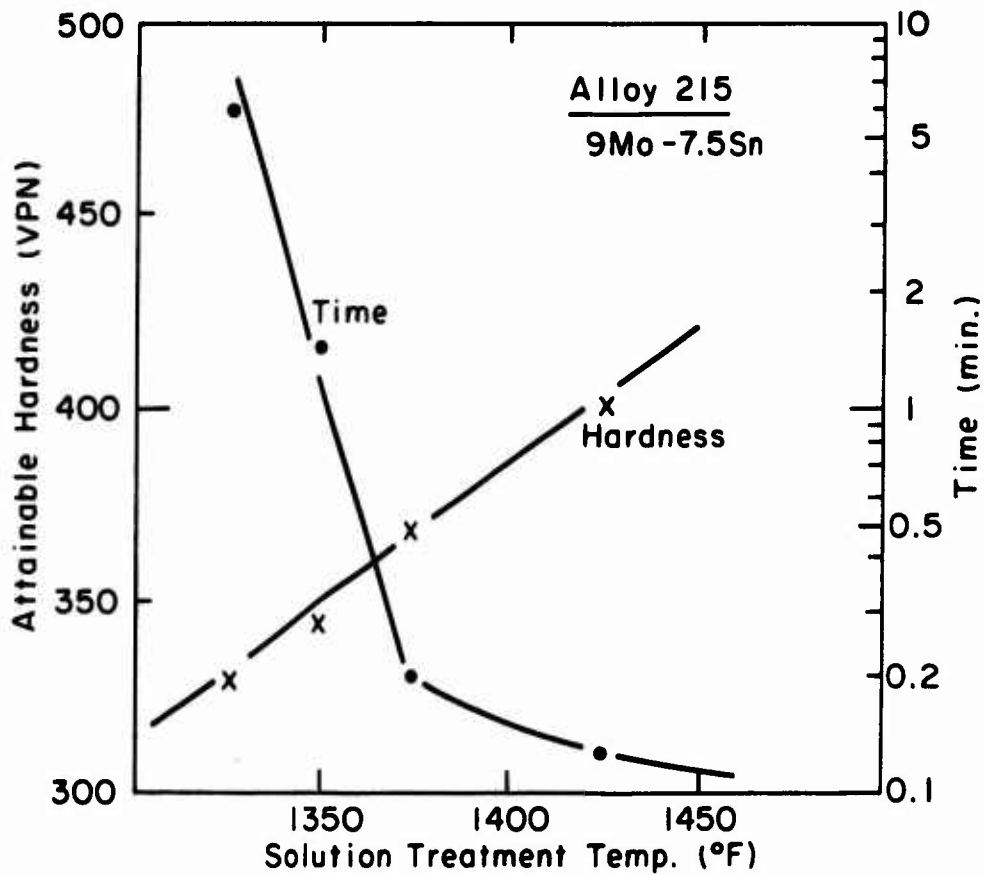

Fig. 3 - Variation of attainable hardness and T-T-T nose time with solution treatment temperature. Alloy 215 - 9Mo-7.5Sn.

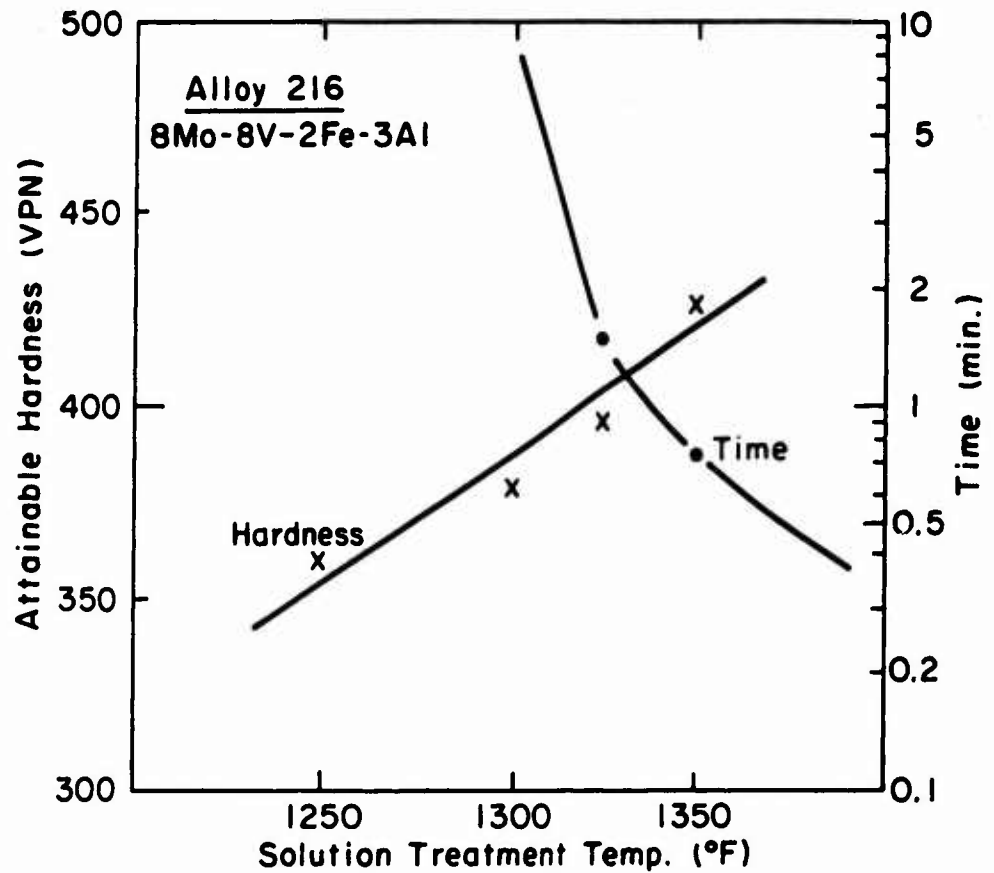

Fig. 4 - Variation of attainable hardness and T-T-T nose time with solution treatment temperature. Alloy 216 - 8Mo-8V-2Fe-3Al.

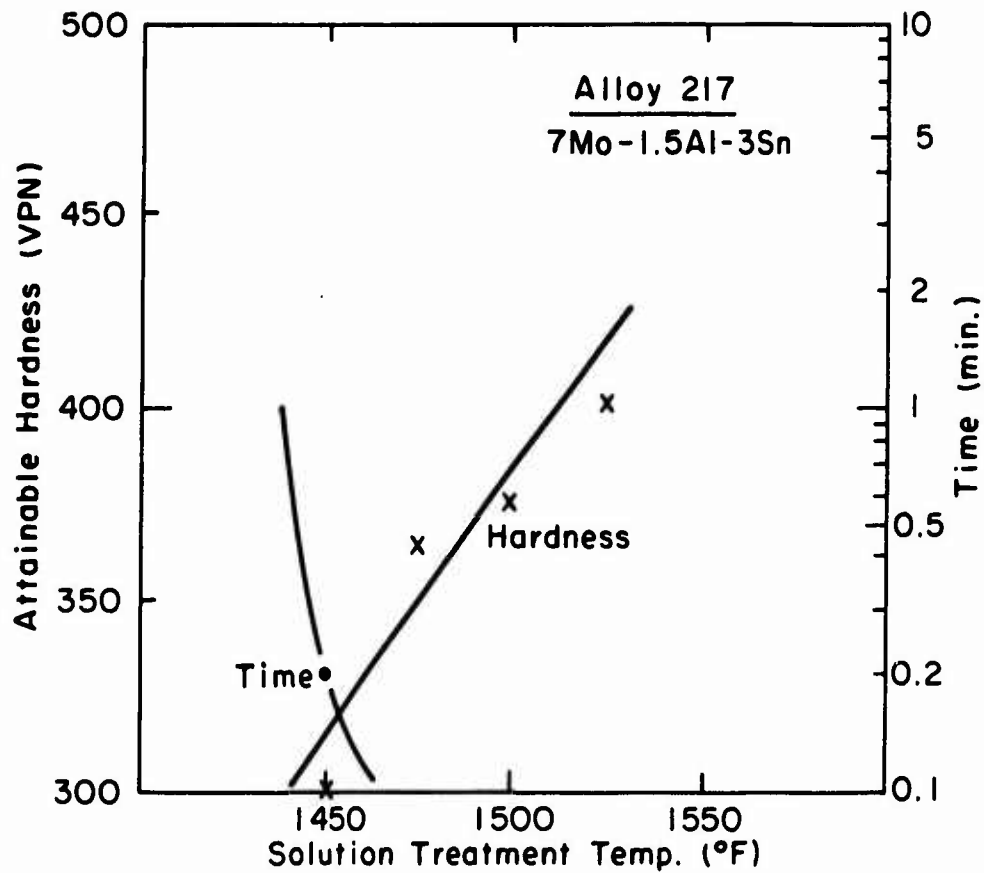

Fig. 5 - Variation of attainable hardness and T-T-T nose time with solution treatment temperature. Alloy 217 - 7Mo-1.5Al-3Sn.

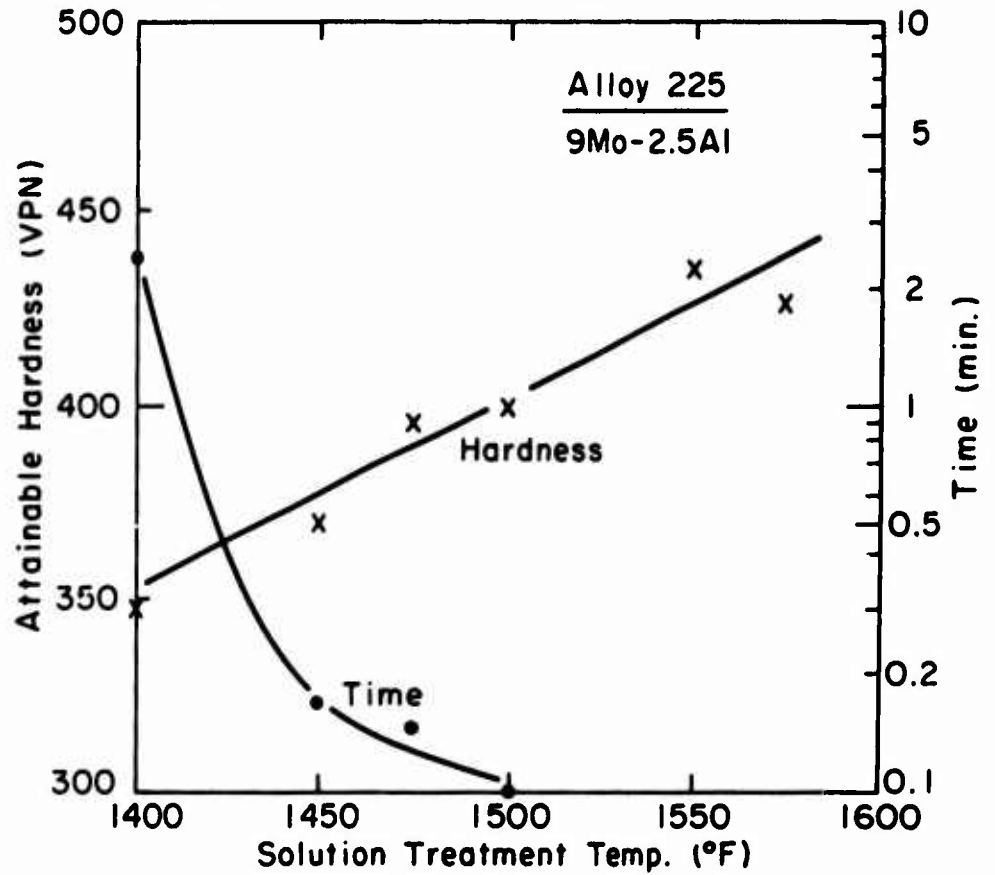

Fig. 6 - Variation of attainable hardness and T-T-T nose time with solution treatment temperature. Alloy 225 - 9Mo-2.5Al.

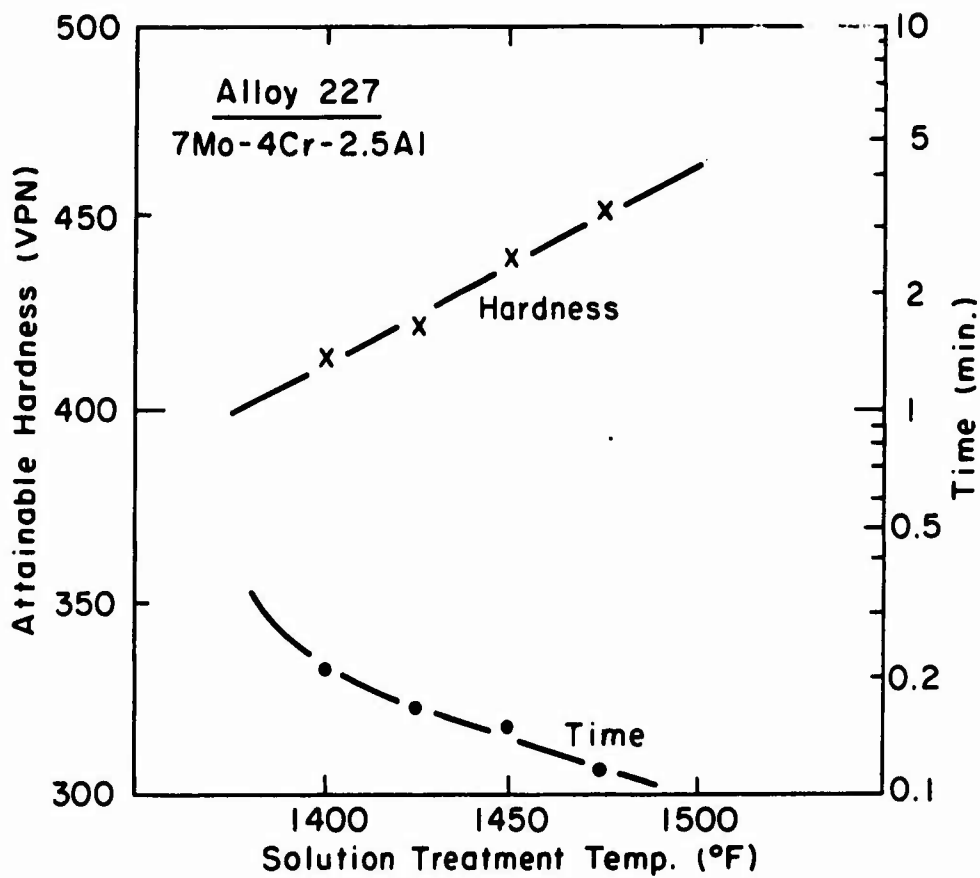

Fig. 7 - Variation of attainable hardness and T-T-T nose time with solution treatment temperature. Alloy 227 - 7Mo-4Cr-2.5Al.

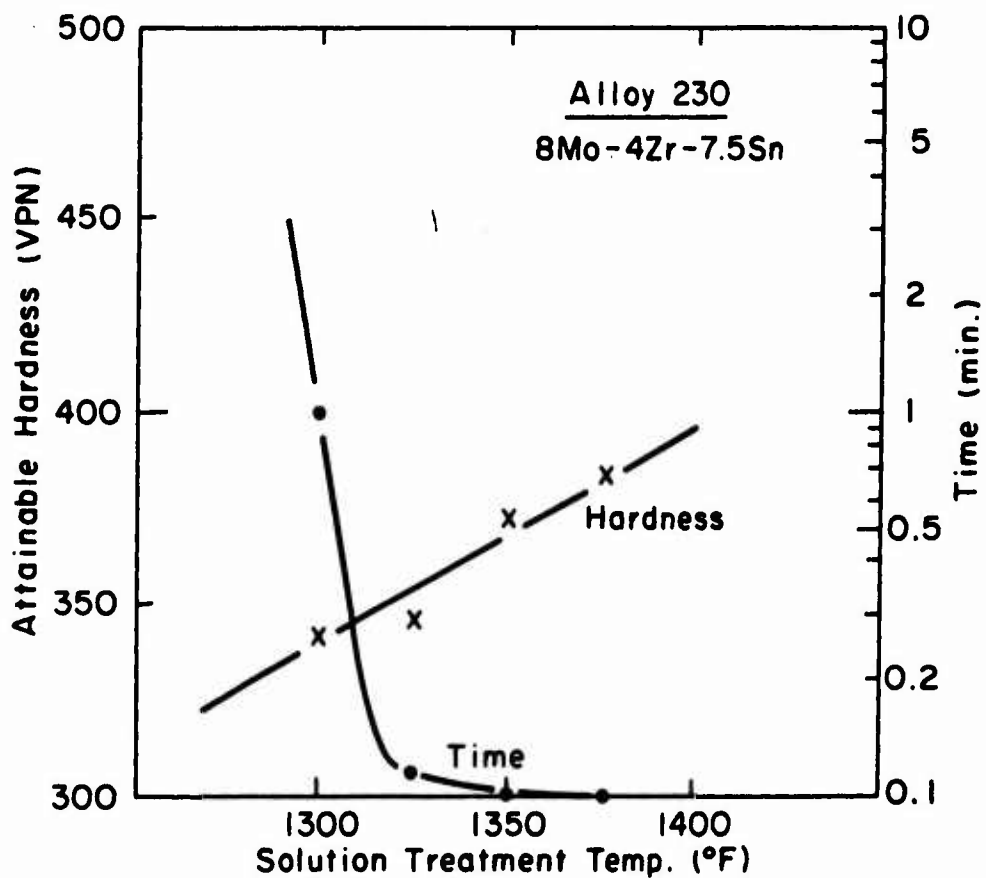

Fig. 8 - Variation of attainable hardness and T-T-T nose time with solution treatment temperature. Alloy 230 - 8Mo-4Zr-7.5Sn.

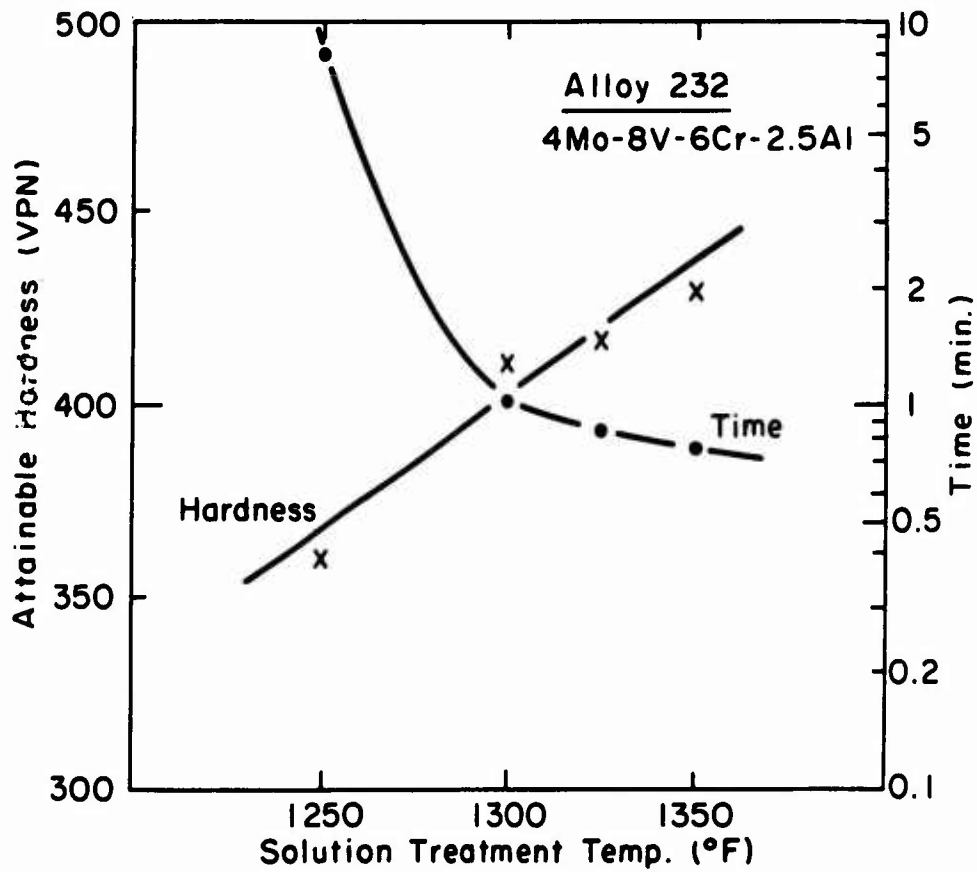

Fig. 9 - Variation of attainable hardness and T-T-T nose time with solution treatment temperature. Alloy 232 - 4Mo-8V-6Cr-2.5Al.

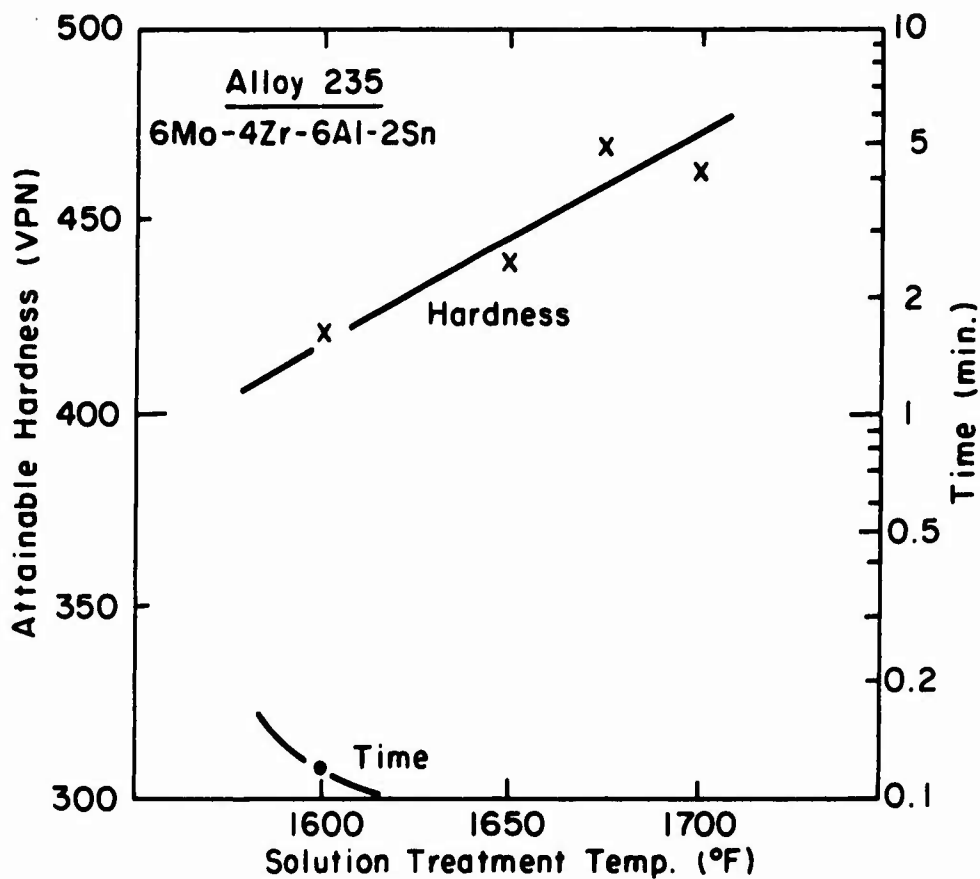

Fig. 10 - Variation of attainable hardness and T-T-T nose time with solution treatment temperature. Alloy 235 - 6Mo-4Zr-6Al-2Sn.

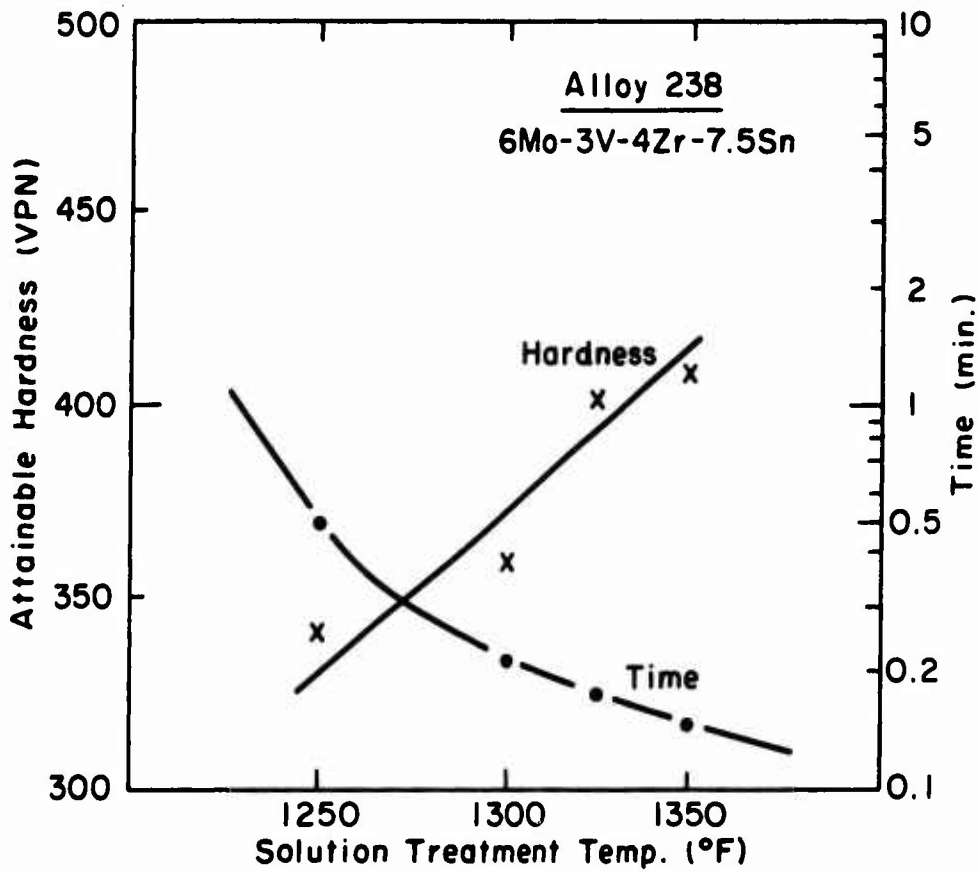

Fig. 11 - Variation of attainable hardness and T-T-T nose time with solution treatment temperature. Alloy 238 - 6Mo-3V-4Zr-7.5Sn.

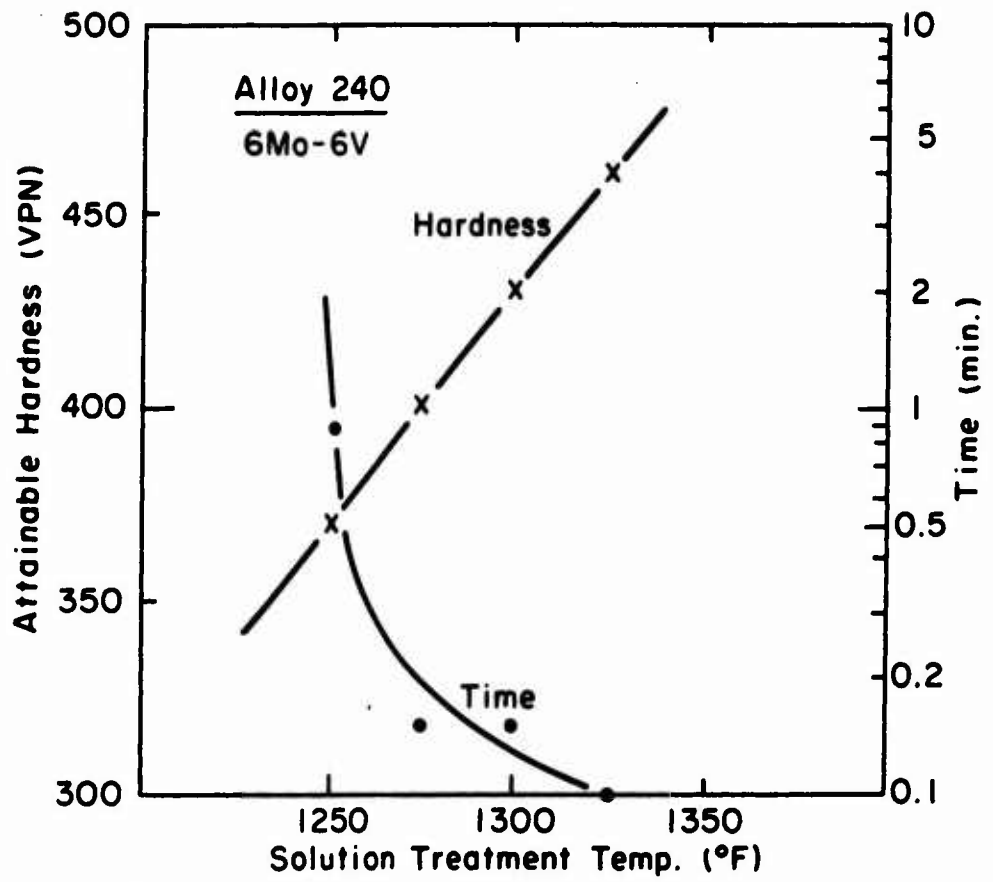

Fig. 12 - Variation of attainable hardness and T-T-T nose time with solution treatment temperature. Alloy 240 - 6Mo-6V.

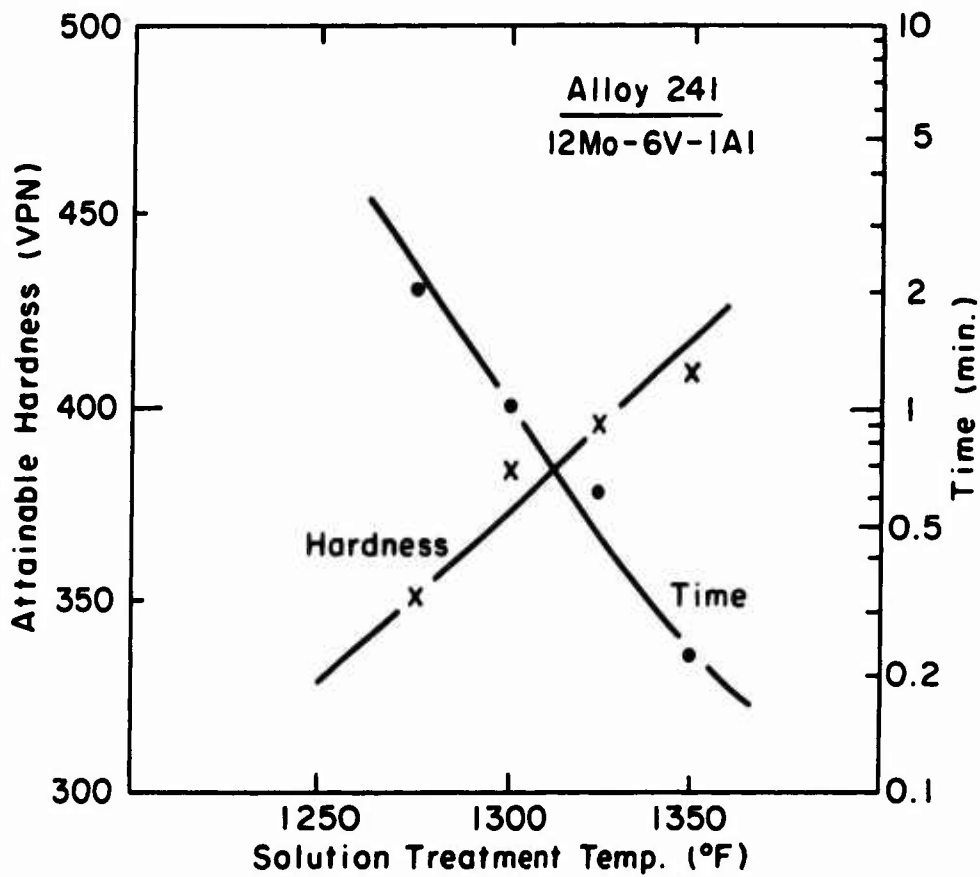

Fig. 13 - Variation of attainable hardness and T-T-T nose time with solution treatment temperature. Alloy 241 - 12Mo-6V-1Al.

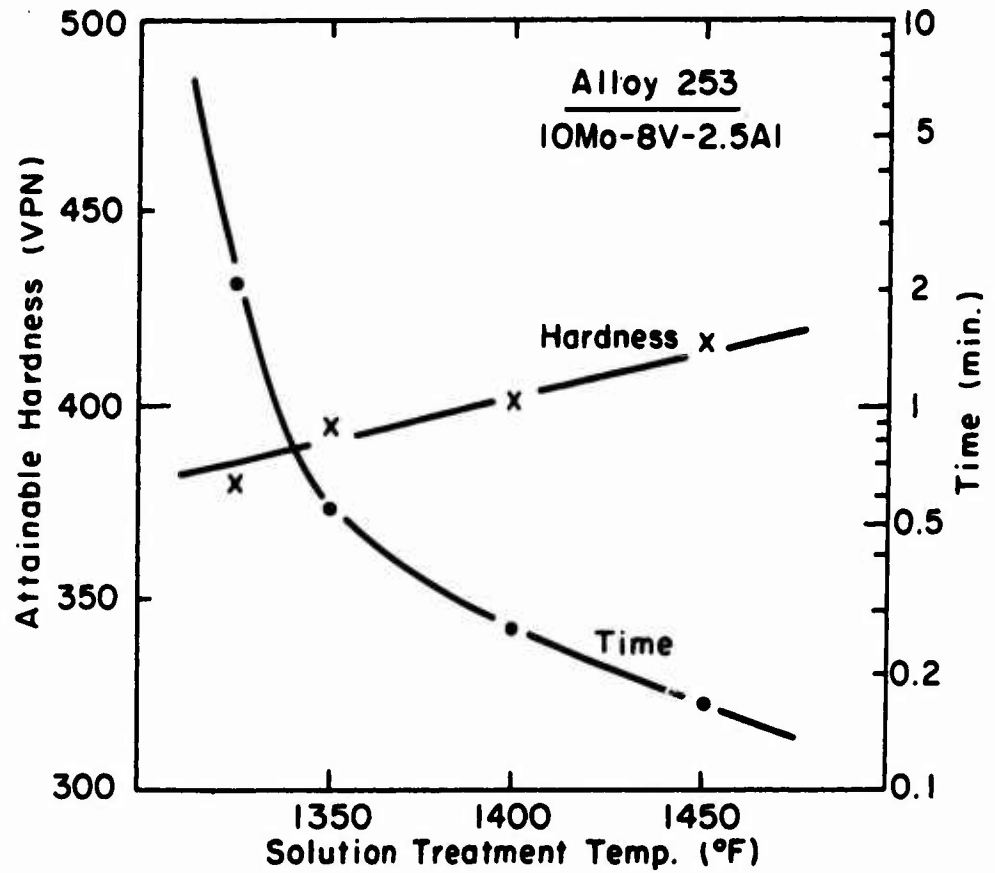

Fig. 14 - Variation of attainable hardness and T-T-T nose time with solution treatment temperature. Alloy 253 - 10Mo-8V-2.5Al.

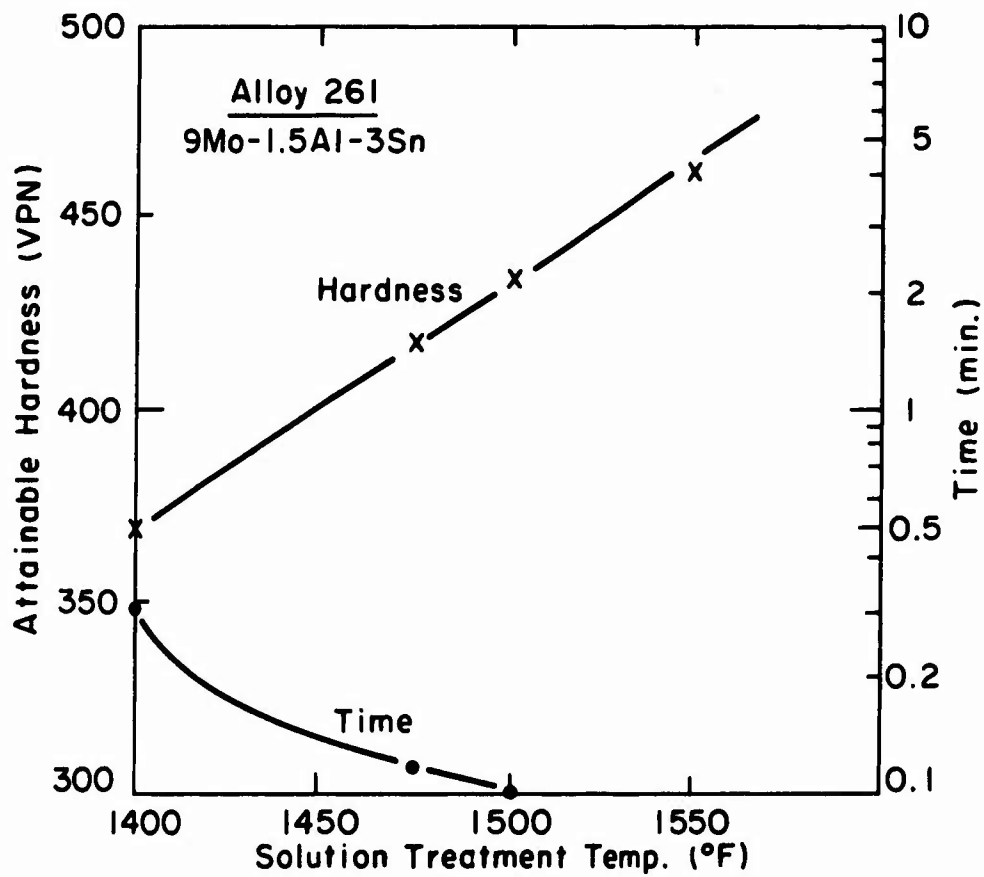

Fig. 15 - Variation of attainable hardness and T-T-T nose time with solution treatment temperature. Alloy 261 - 9Mo-1.5Al-3Sn.

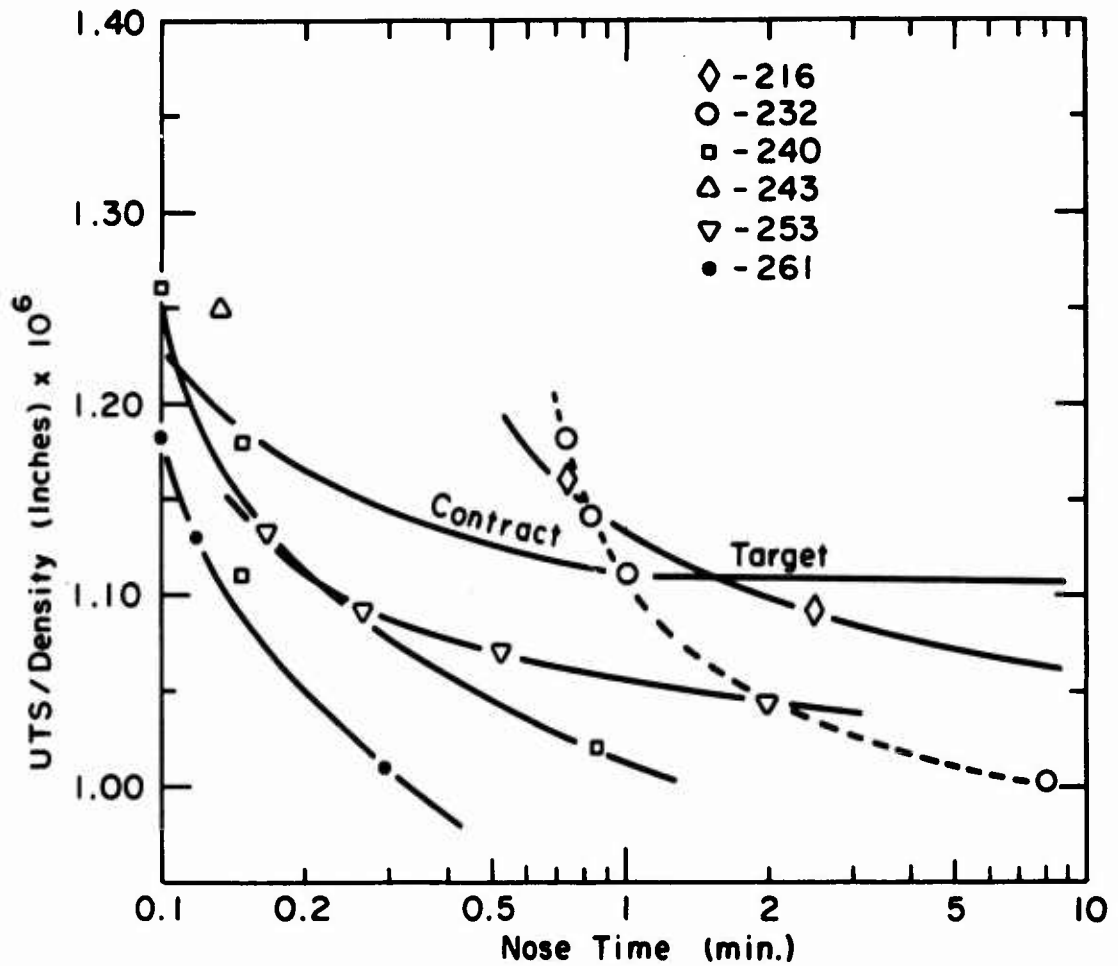

Fig. 16 - Comparison of strength potential and nose time of selected "good" alloys with contract target curve. Alloy parameters are obtained directly from Figures 3-15, hardness values being converted to UTS (Figure 1) and normalized by dividing by density.

- Alloy 216 - 8Mo-8V-2Fe-3Al
- Alloy 232 - 4Mo-8V-6Cr-2.5Al
- Alloy 240 - 6Mo-6V
- Alloy 243 - 11Mo-1Al-0.5Si
- Alloy 253 - 10Mo-8V-2.5Al
- Alloy 261 - 9Mo-1.5Al-3Sn

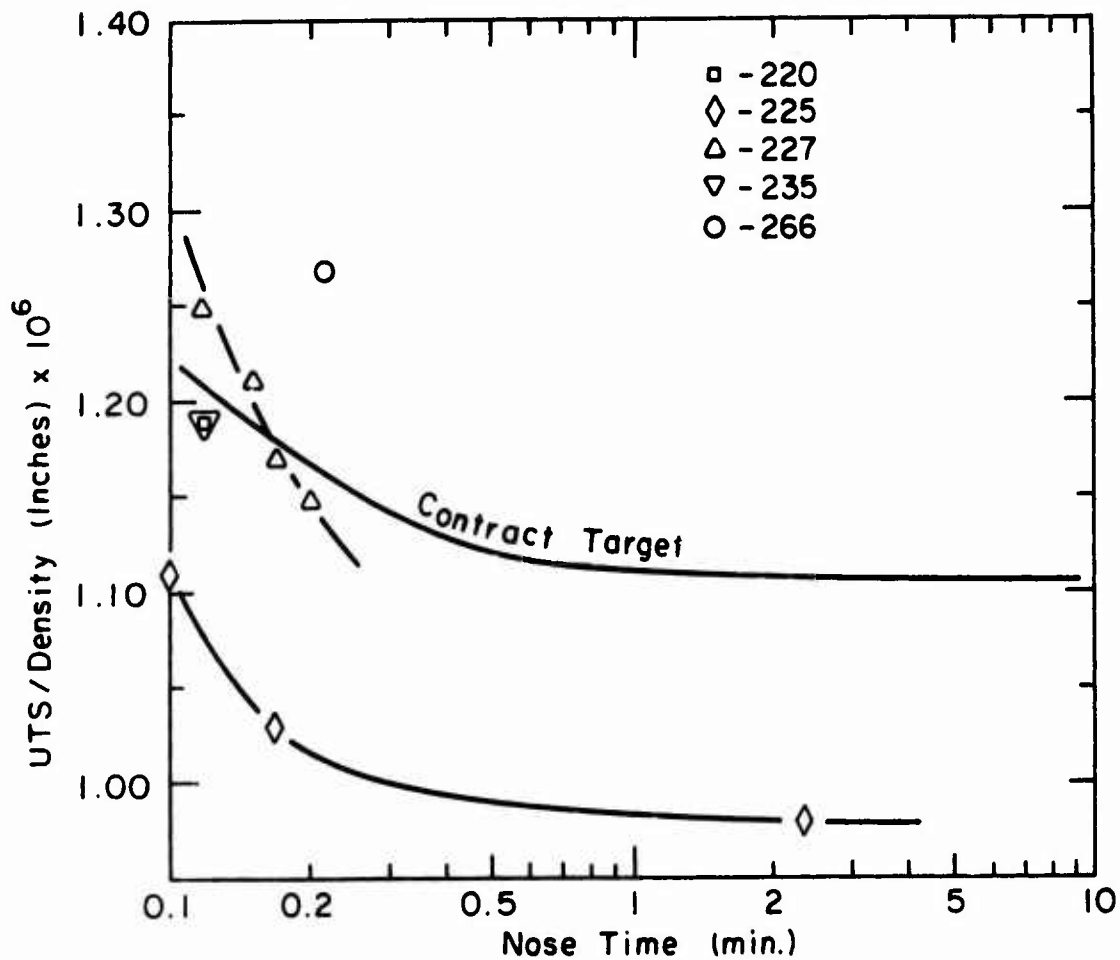

Fig. 17- Comparison of strength potential and nose time of selected "good" alloys with contract target curve. Alloy parameters are obtained directly from Figures 3-15, hardness values being converted to UTS (Figure 1) and normalized by dividing by density.

- Alloy 220 - 11Mo-2.5Al
- Alloy 225 - 9Mo-2.5Al
- Alloy 227 - 7Mo-4Cr-2.5Al
- Alloy 232 - 4Mo-8V-6Cr-2.5Al
- Alloy 266 - 11Mo-4Al

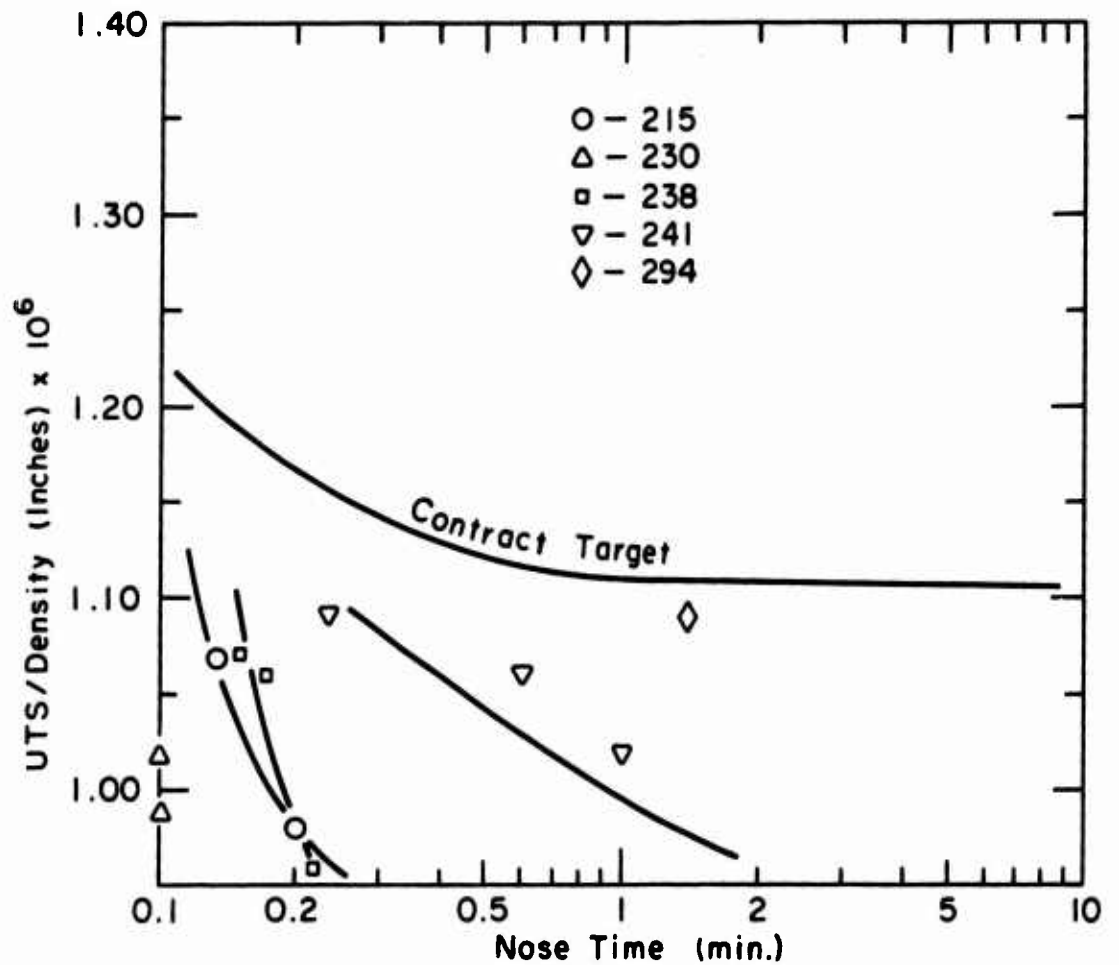

Fig. 18 - Comparison of strength potential and nose time of selected "good" alloys with contract target curve. Alloy parameters are obtained directly from Figures 3-15, hardness values being converted to UTS (Figure 1) and normalized by dividing by density.

- Alloy 215 - 9Mo-7.5Sn
- Alloy 230 - 8Mo-4Zr-7.5Sn
- Alloy 238 - 6Mo-3V-4Zr-7.5Sn
- Alloy 241 - 12Mo-6V-1Al
- Alloy 294 - 11.5Mo-6Zr-4.5Sn



Fig. 19 - Alloy 261, ST 1450F-2 hrs, aged 900F-4 hrs.



Fig. 20 - Alloy 227, ST 1400F-4 hrs, aged 900F-8 hrs.

Transverse cross section of simulated cooled Charpy. X8.5



Fig. 21 - Alloy 216, ST 1300F-4 hrs, aged 900F-96 hrs.



Fig. 22 - Alloy 334, ST 1325F-4 hrs, aged 875F-96 hrs.

Transverse cross section of simulated cooled Charpy. X8.5

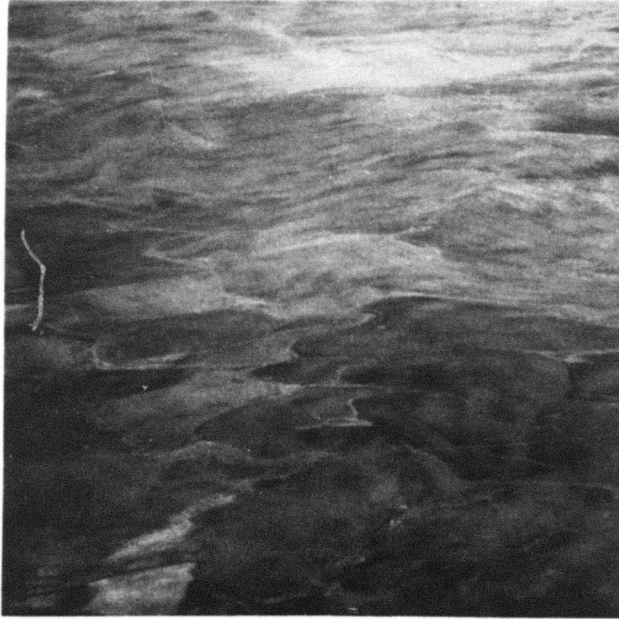

Fig. 23 - Alloy 337, ST 1350F-4 hrs, aged 875F-24 hrs.

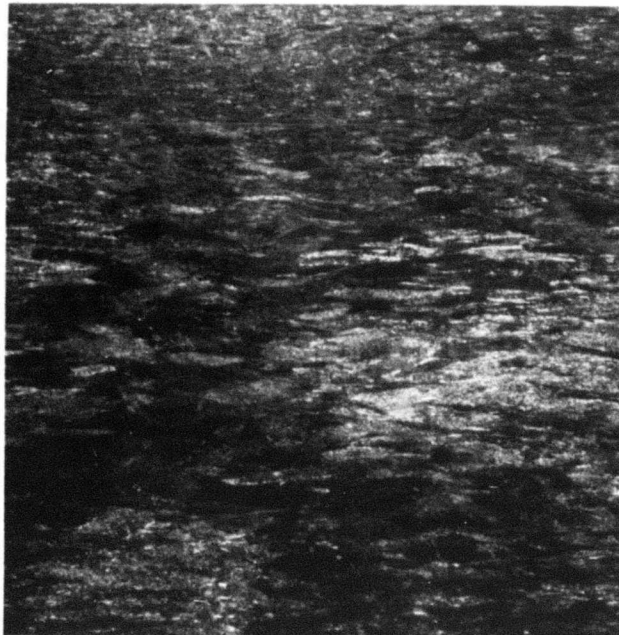

Fig. 24 - Alloy 235, ST 1575F-1 hr, aged 1100F-8 hrs.

Transverse cross section of simulated cooled Charpy. X8.5

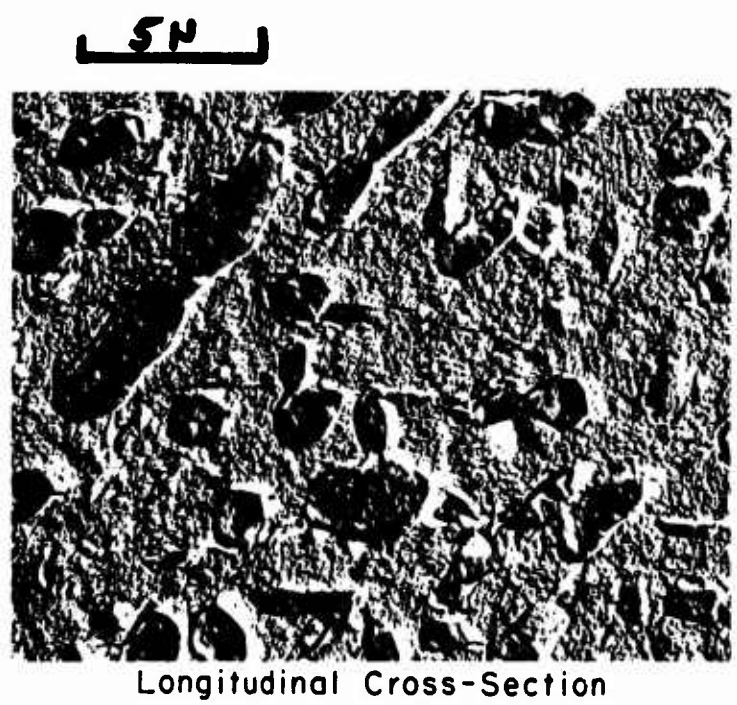
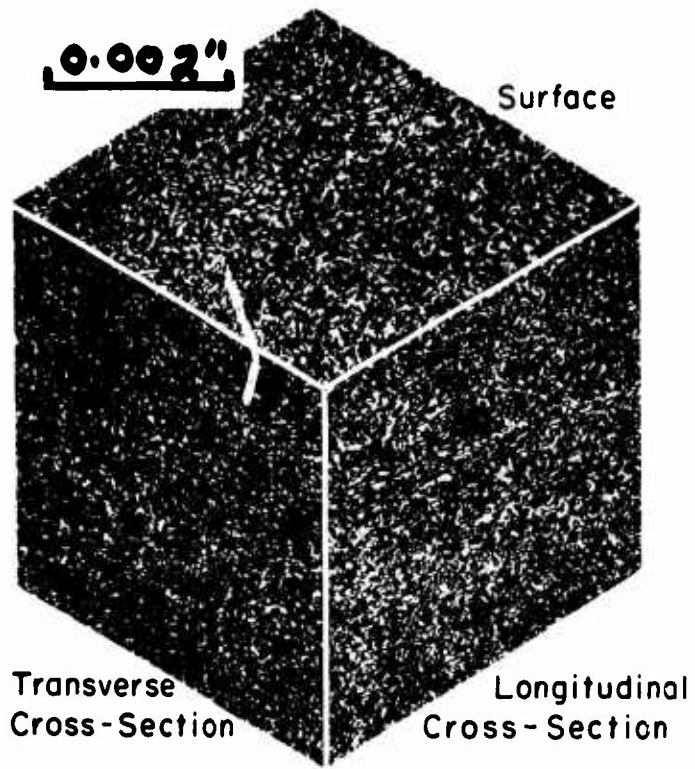

Fig. 25 - Alloy 261, ST 1450F-2 hrs, simulated cooled, aged 900F - 4 hrs. Optical isometric X500. Surface replica X5,200.

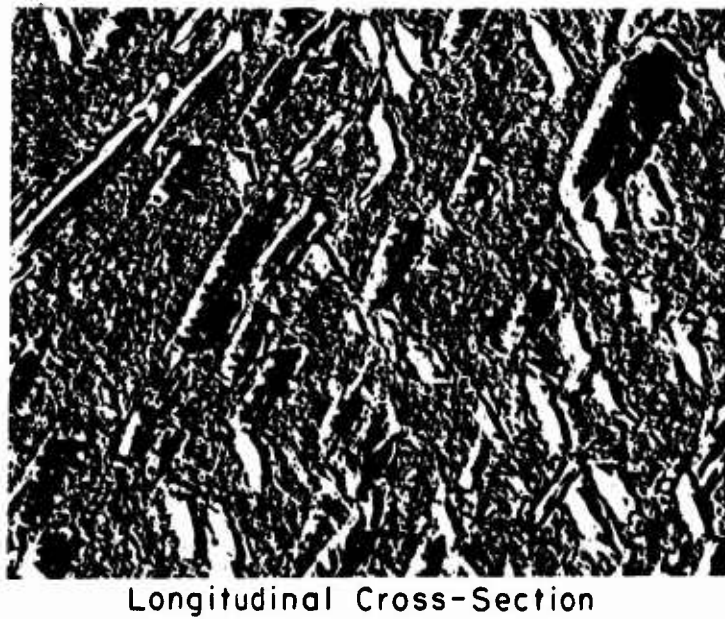
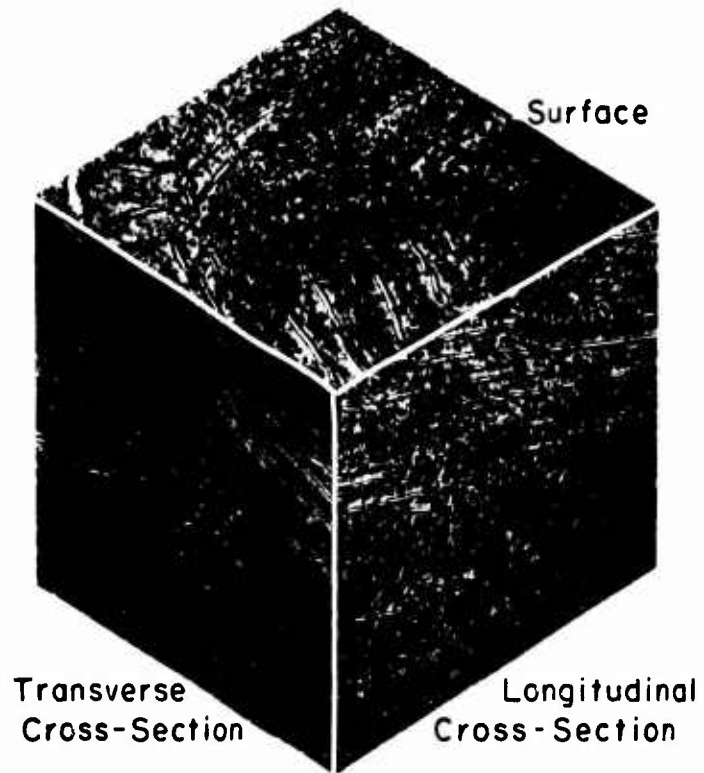
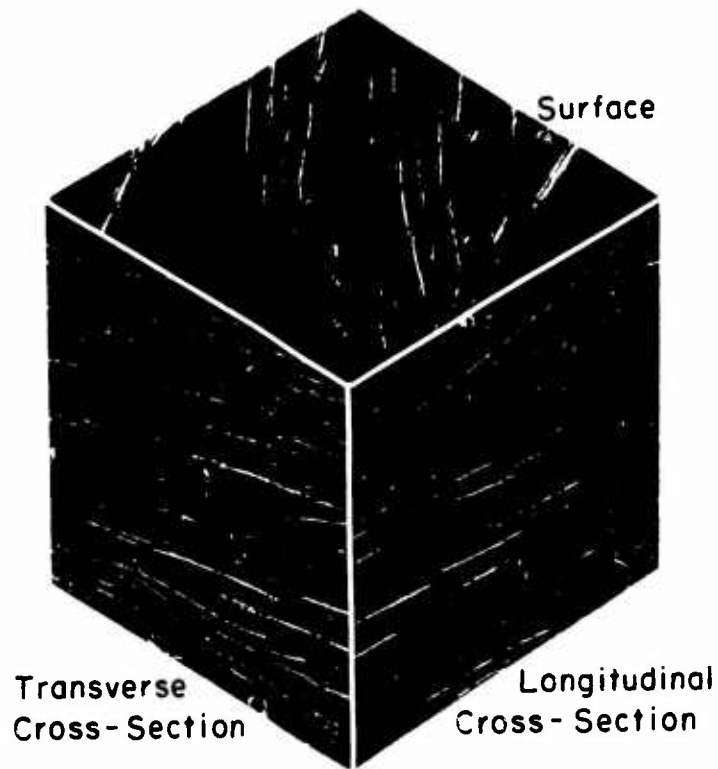

Fig. 26 - Alloy 227, ST 1400F-4 hrs, simulated cooled, aged 900F-hrs. Optical isometric X500. Surface replica X5,200.



Longitudinal Cross-Section

Fig. 27 - Alloy 216, ST 1300F-4 hrs, simulated cooled, aged 900F-96 hrs. Optical isometric X500. Surface replica X5,200.

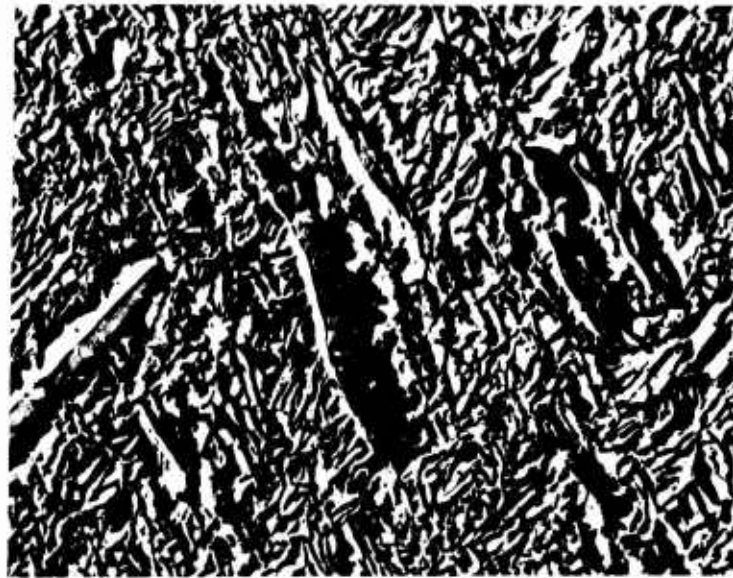
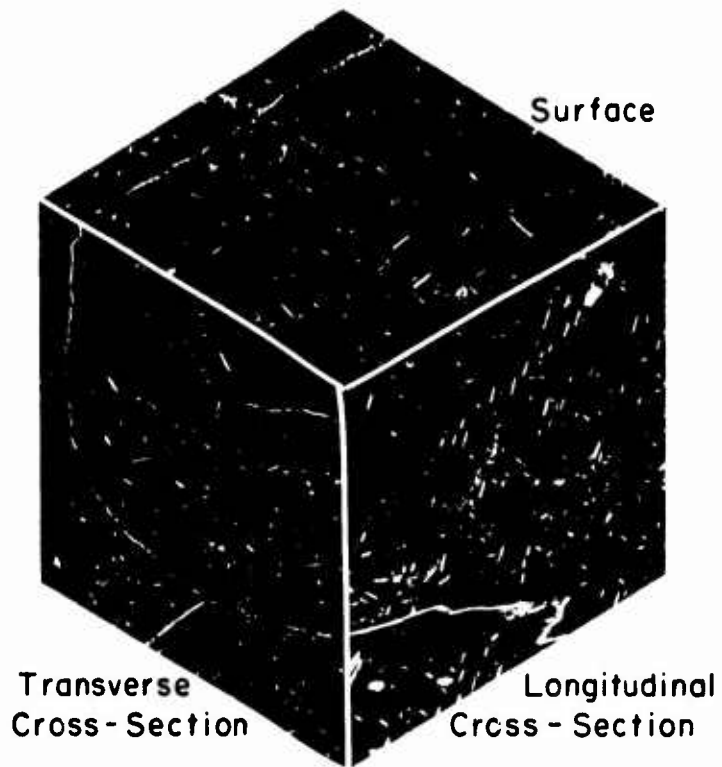
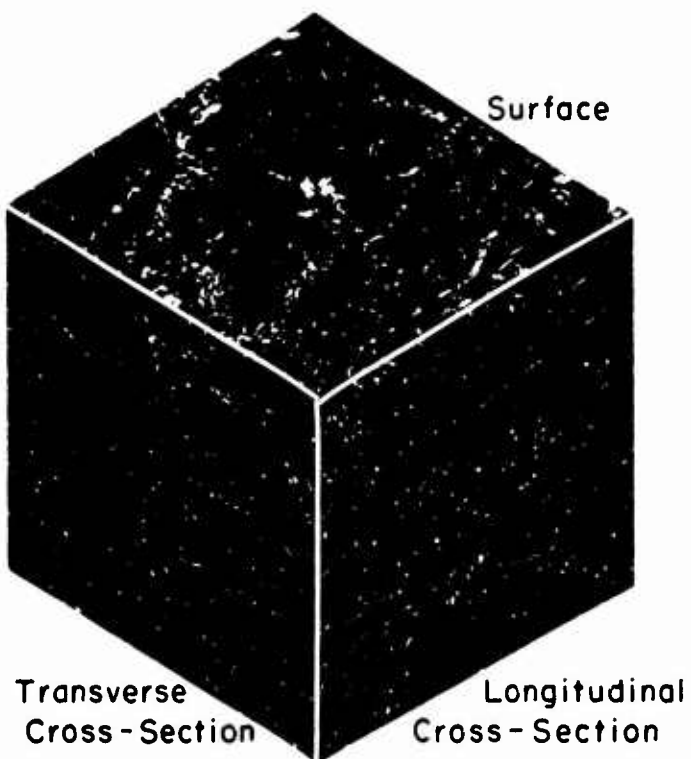
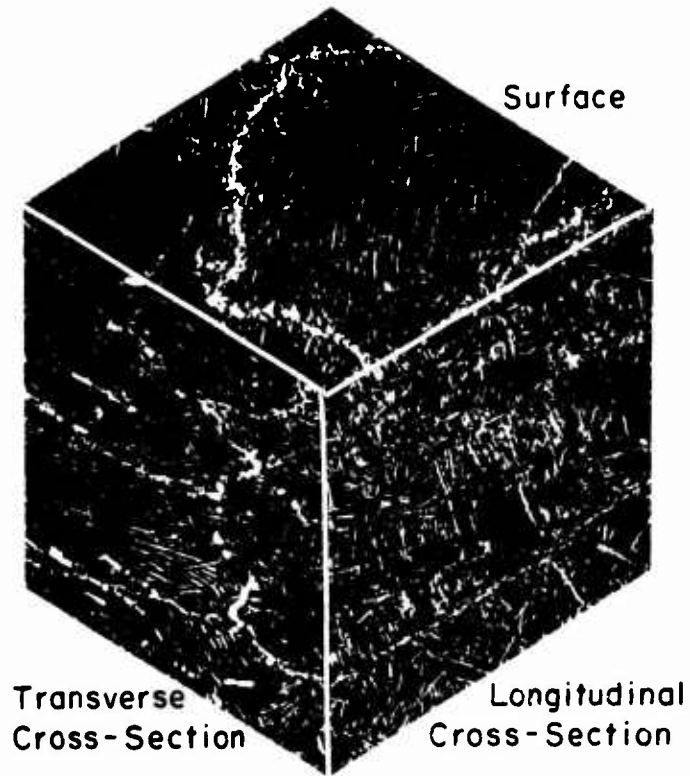

Fig. 28 - Alloy 334, ST 1325F-4 hrs, simulated cooled, aged 875F-96 hrs. Optical isometric X500. Surface replica X5,200.



Longitudinal Cross-Section

Fig. 29 - Alloy 337, ST 1350F-4 hrs, simulated cooled, aged 875F-24 hrs. Optical isometric X500. Surface replica X5,200.



Longitudinal Cross-Section

Fig. 30 - Alloy 235, ST 1575F-1 hr, simulated cooled, aged 1100F-8 hrs. Optical isometric X500. Surface replica X5,200.

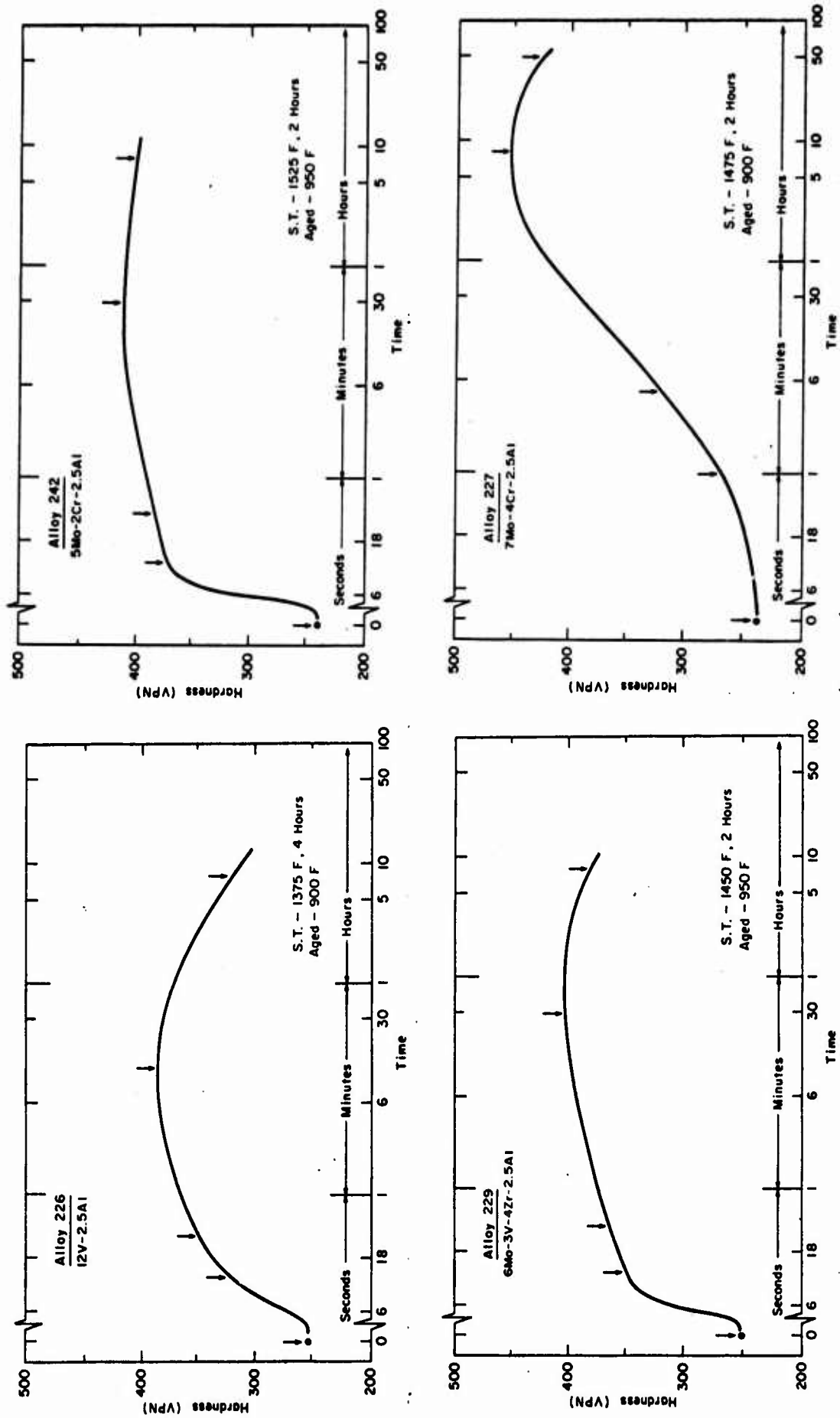

Figure 31 - Hardening response for alloys containing primary alpha and orthorhombic martensite as solution treated.

↓: Samples examined for fine structure analysis.

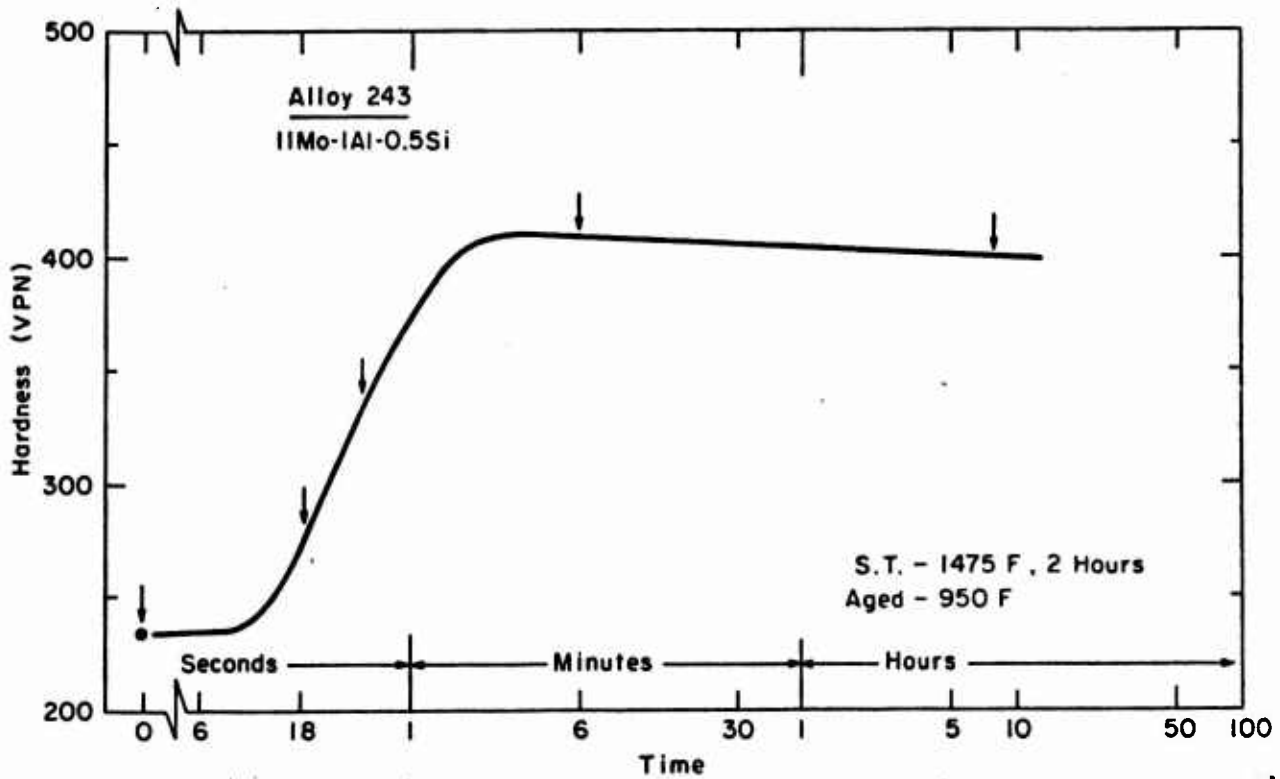
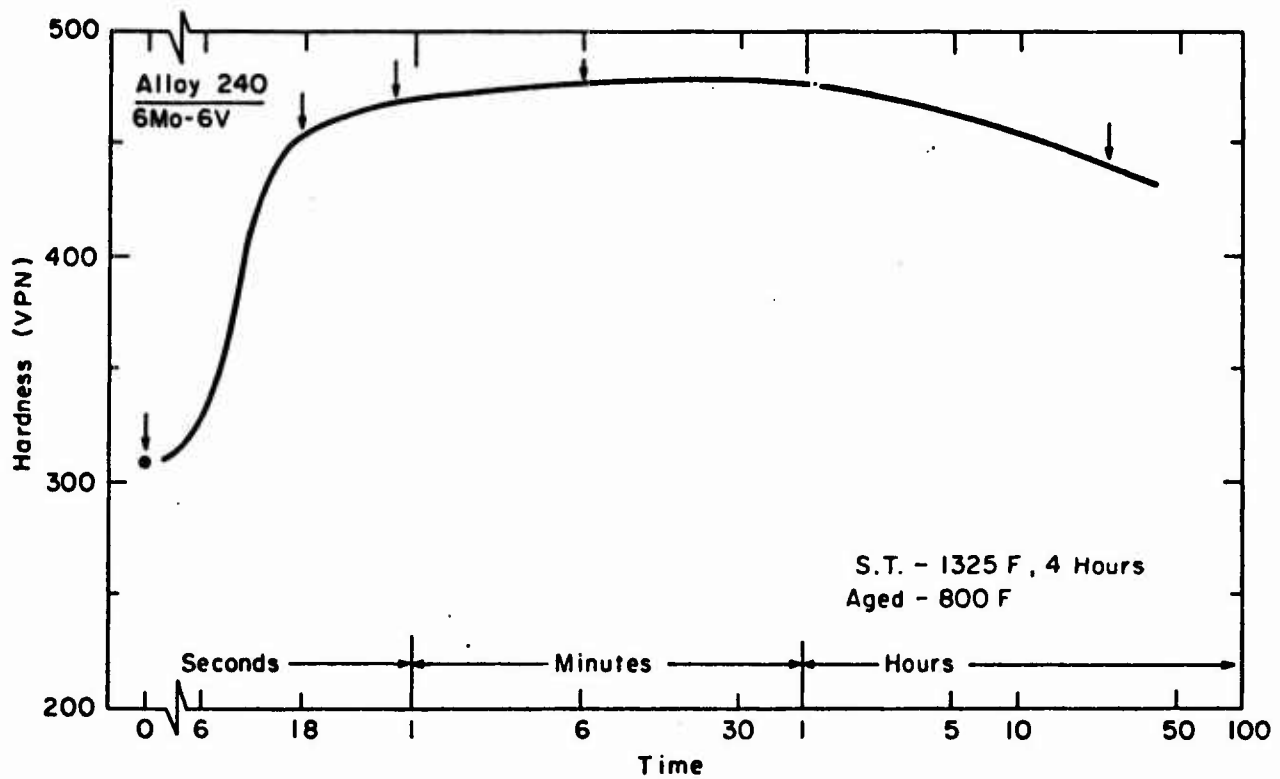

Figure 32 - Hardening response for alloys containing primary alpha, beta and omega.

↓ : Samples examined for fine structure analysis.

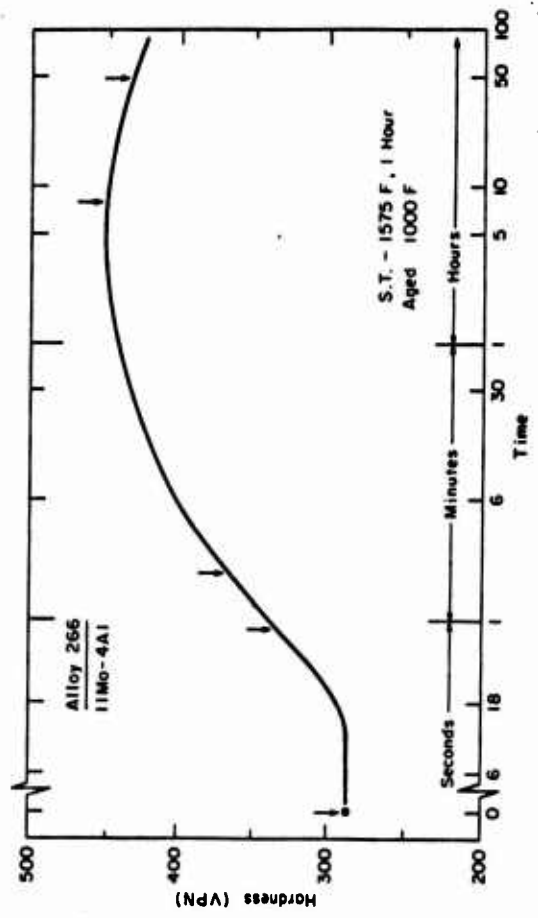
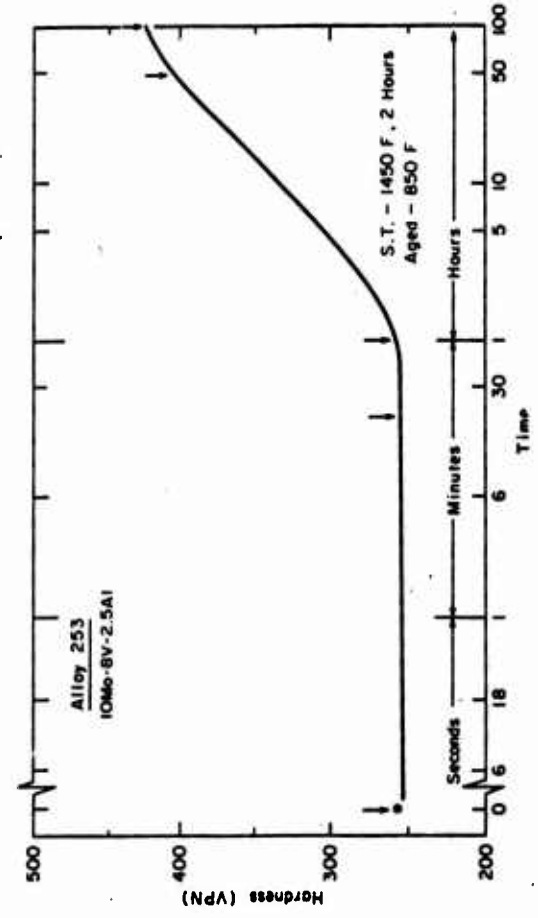
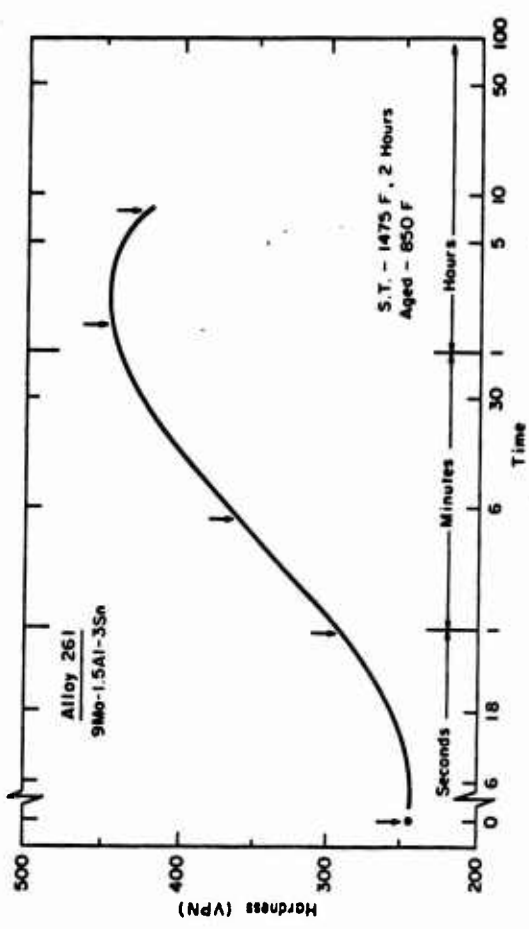
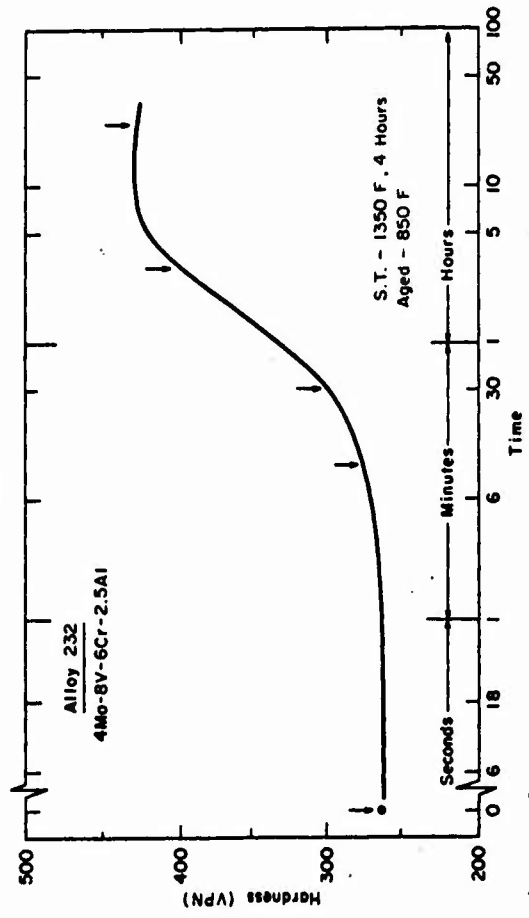
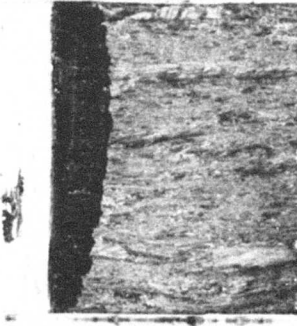
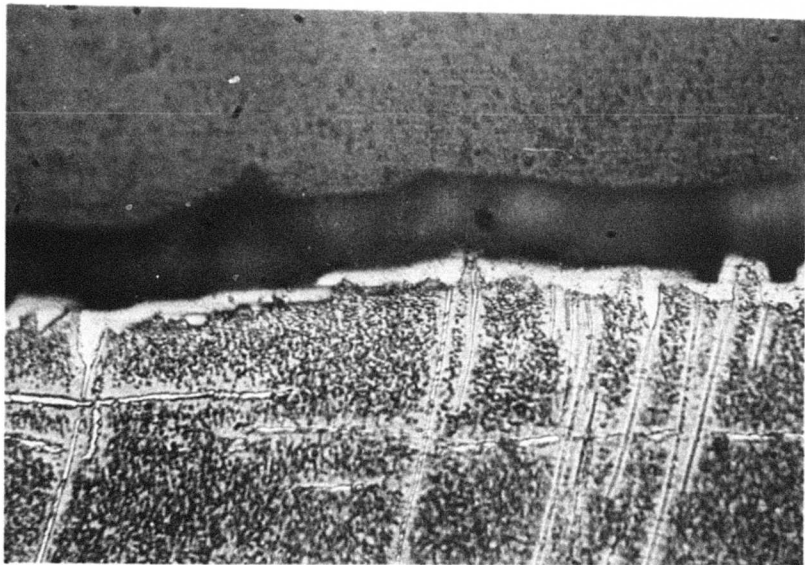

Figure 33 - Hardening response for alloys containing primary alpha and beta.
 ↓: Samples examined for fine structure analysis.



Fracture surface transverse (WR) Charpy X4



Fracture path from above. Crack propagated
right to left. X500

Fig. 34 - Alloy 227, ST 1400F-4 hrs, simulated cooled, aged
900F-8 hrs.

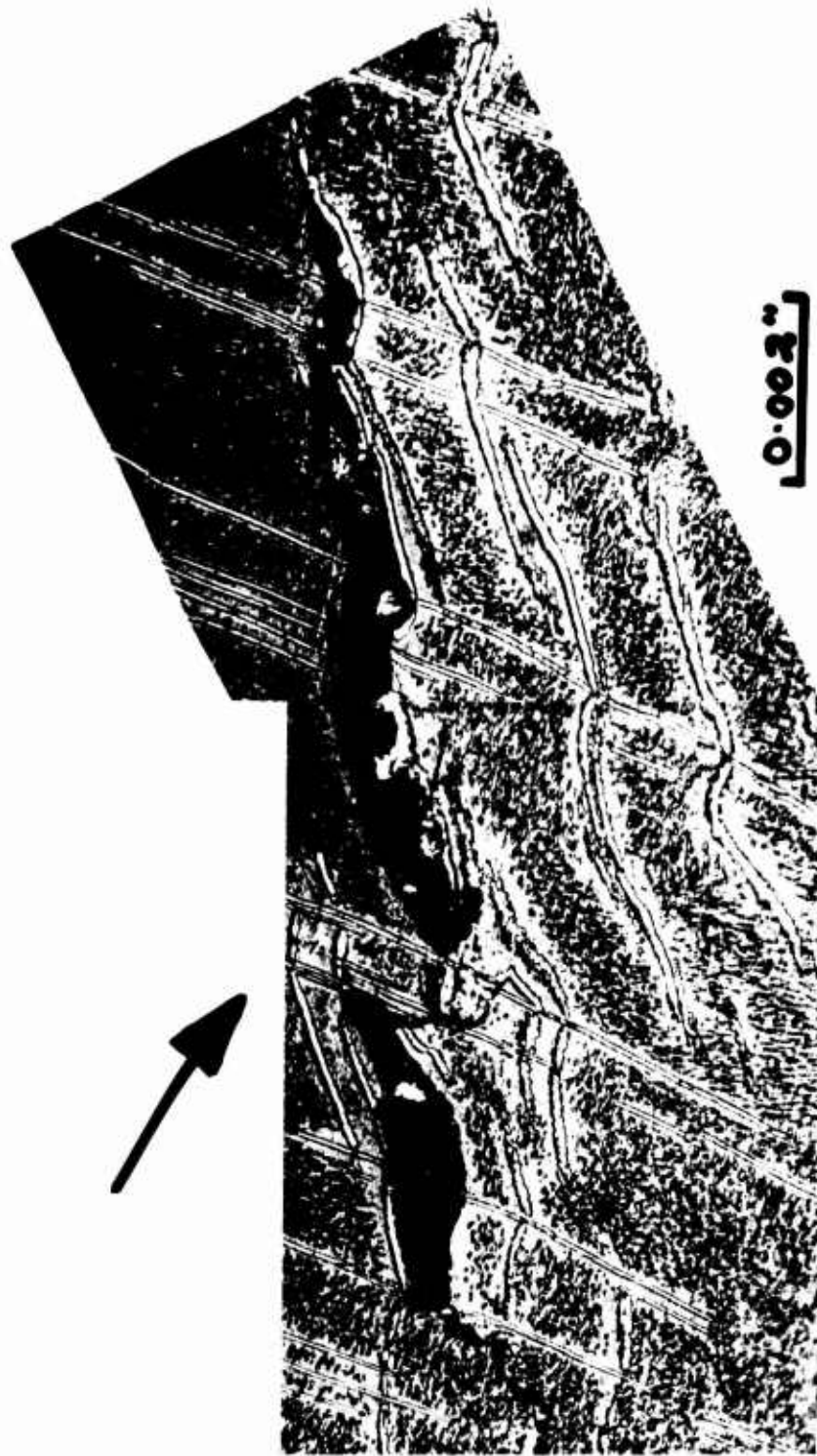
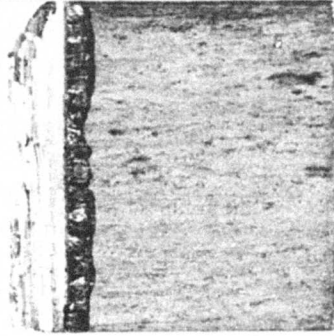
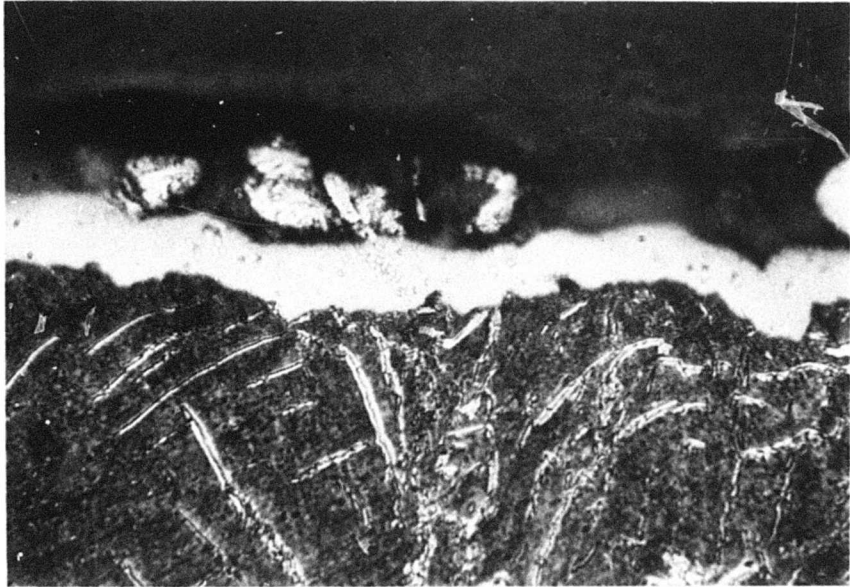

Fig. 35 - Alloy 227, ST 1400-4 hrs, simulated cooled, aged 900F-8 hrs.
Internal fracture path from Fig. 52. Crack propagated bottom to top. X500



Fracture surface transverse (WR) Charpy X4



Fracture path from above. Crack propagated
right to left. X500

Fig. 36 - Alloy 216, ST 1300F-4 hrs, simulated cooled, aged
900F-96 hrs.

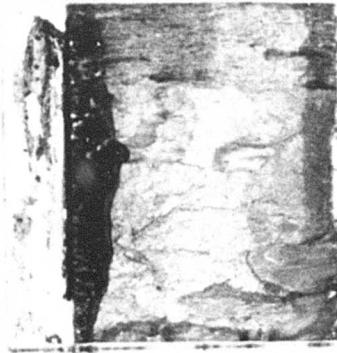

Fracture surface transverse (WR) Charpy X4



Fracture path from above. Crack propagated
left to right. X500

Fig. 37 - Alloy 334, ST 1325F-4 hrs, simulated cooled, aged
875F-96 hrs.

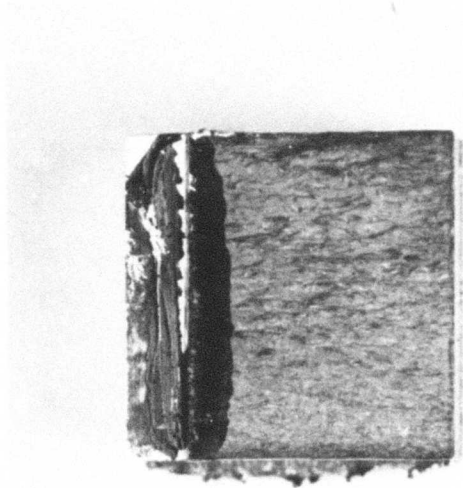

Fracture surface transverse (WR) Charpy X4

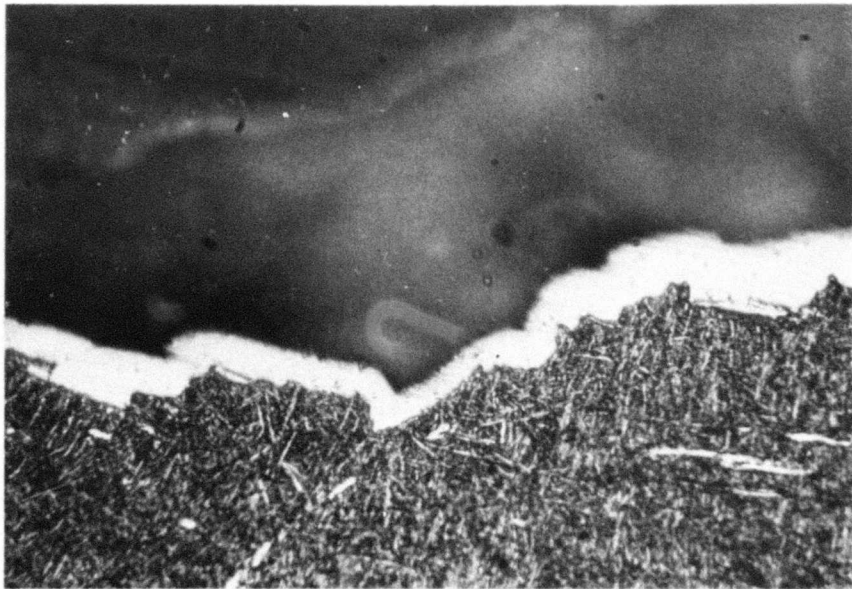

Fracture path from above. Crack propagated
left to right. X500

Fig. 38 - Alloy 235, ST 1575F-1 hr, simulated cooled, aged
1100F-8 hrs.

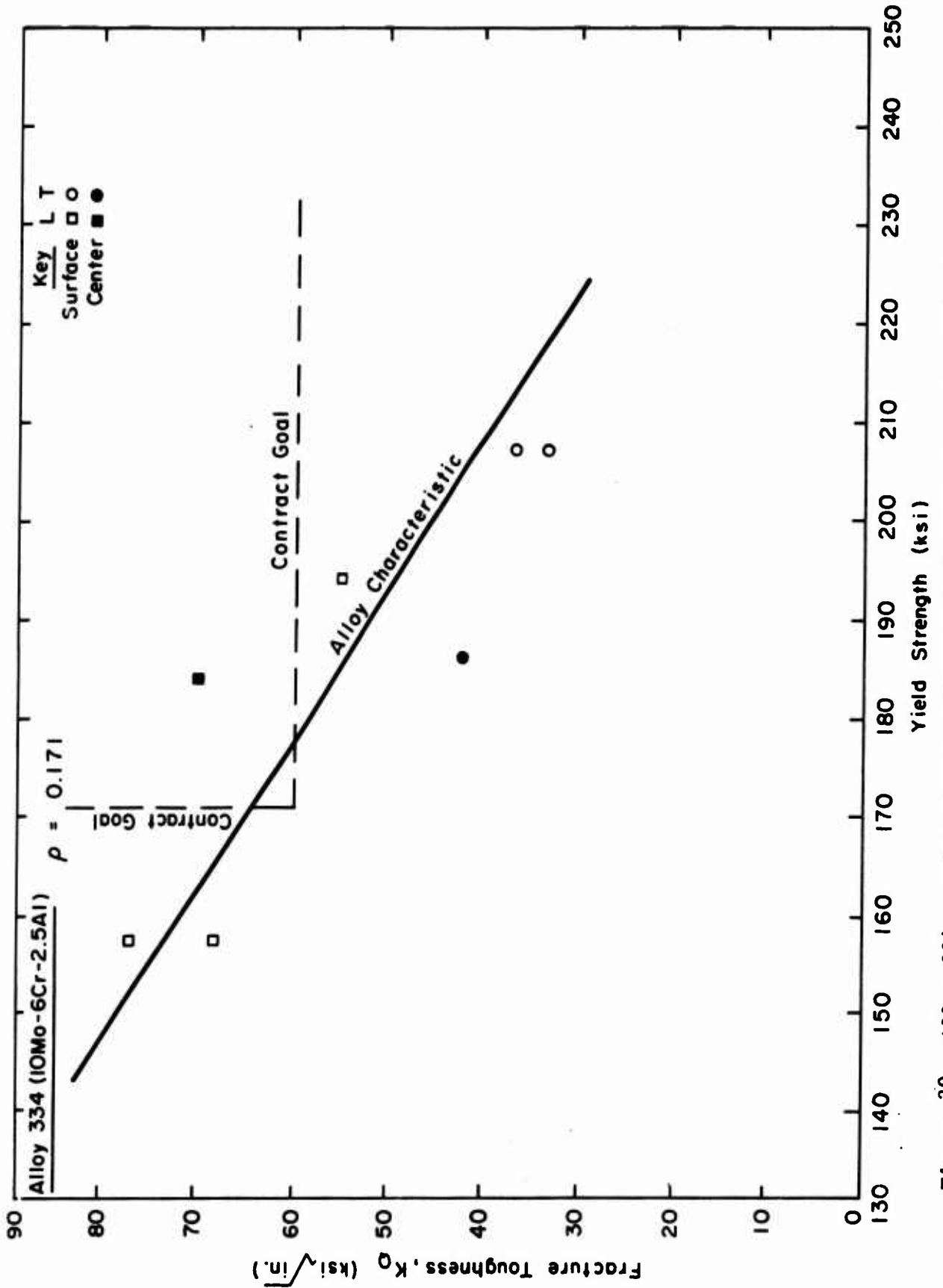

Figure 39 - Alloy 334. Fracture toughness-yield strength characteristic alloy trend lines. Defined using the data from Tables XX and XXI.

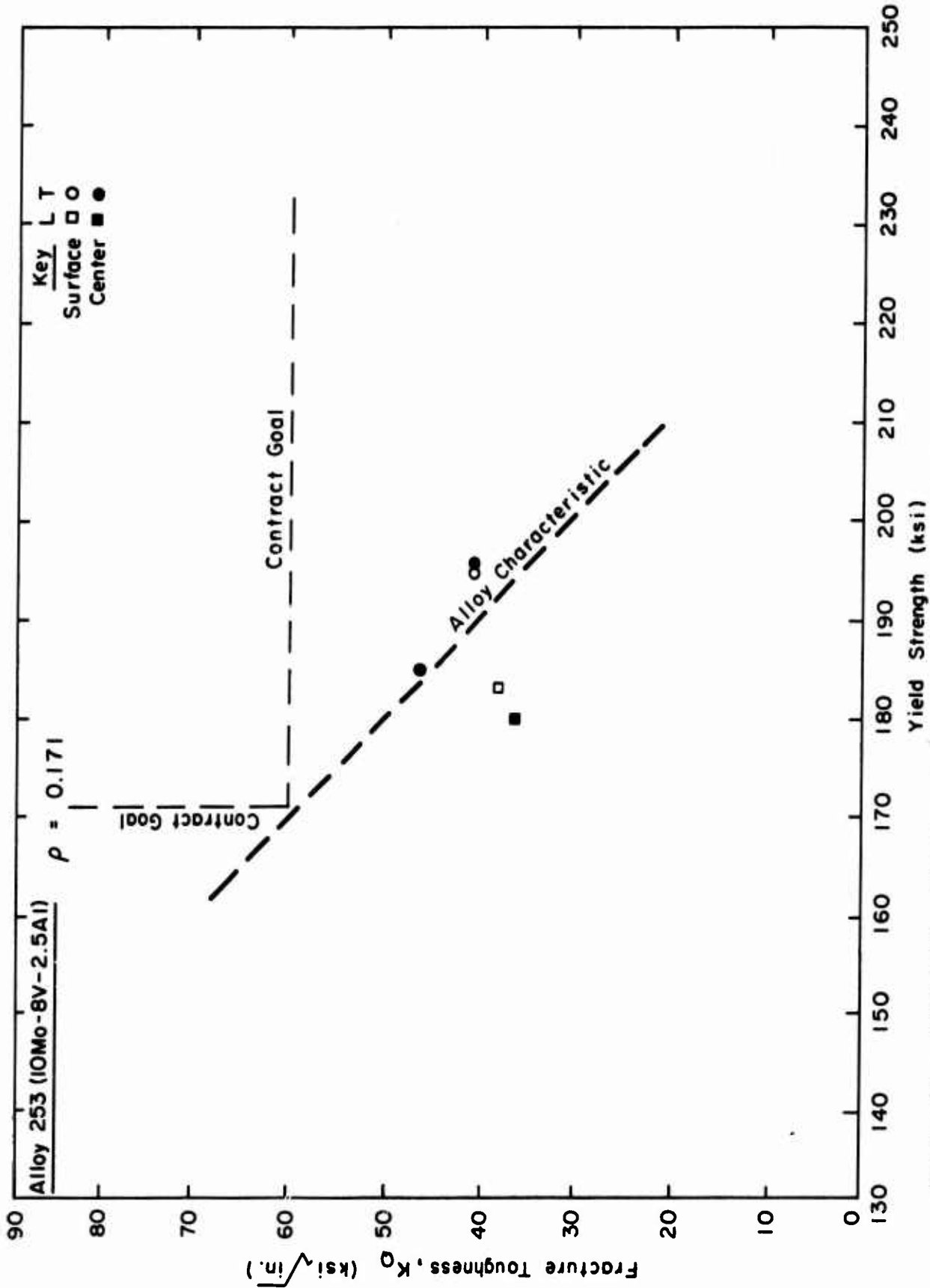

Figure 40 - Alloy 253. Fracture toughness-yield strength characteristic alloy trend lines. Defined using the data from Tables XX and XXI.

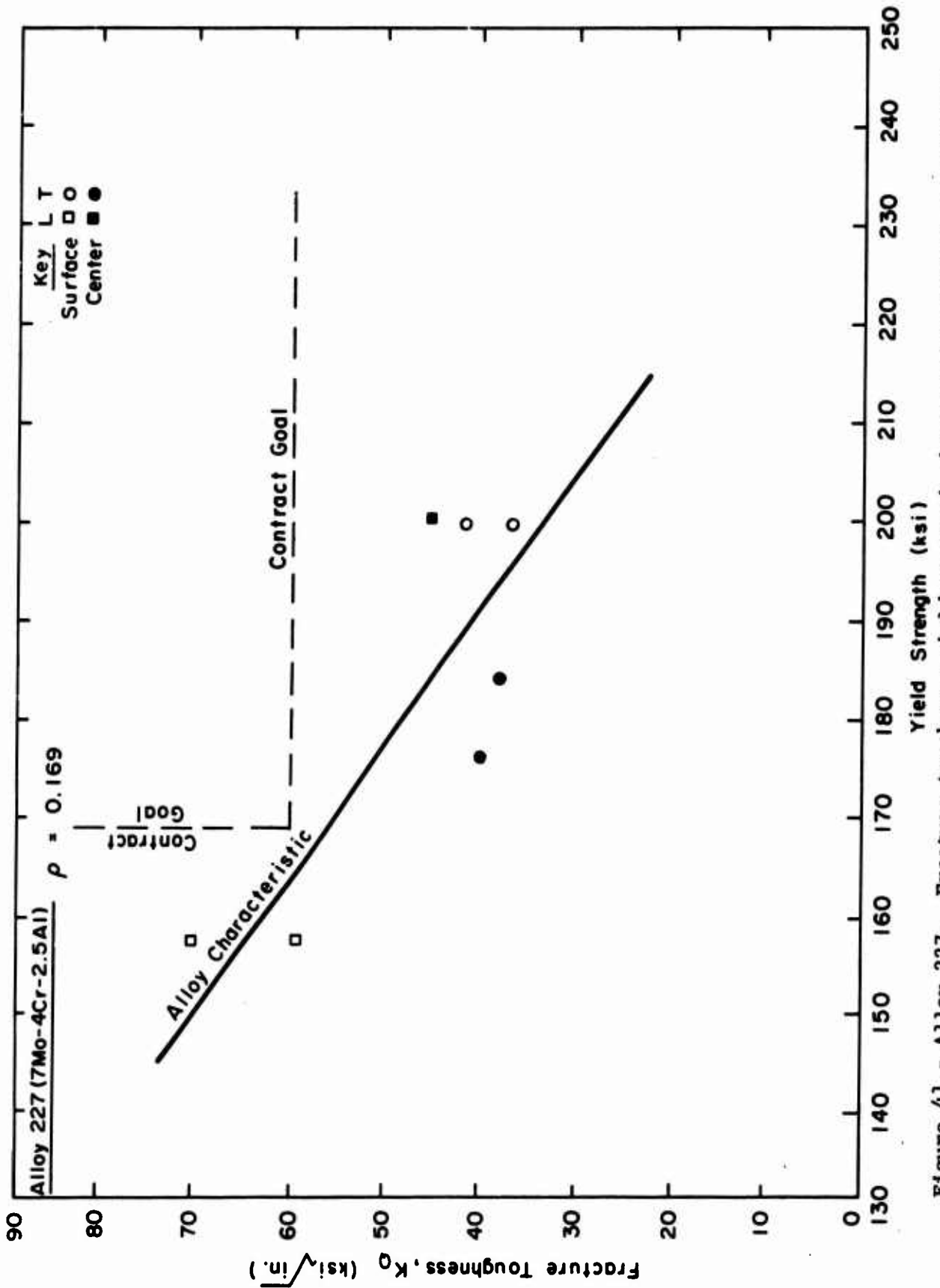

Figure 41 - Alloy 227. Fracture toughness-yield strength characteristic alloy trend lines. Defined using the data from Tables XX and XXI.

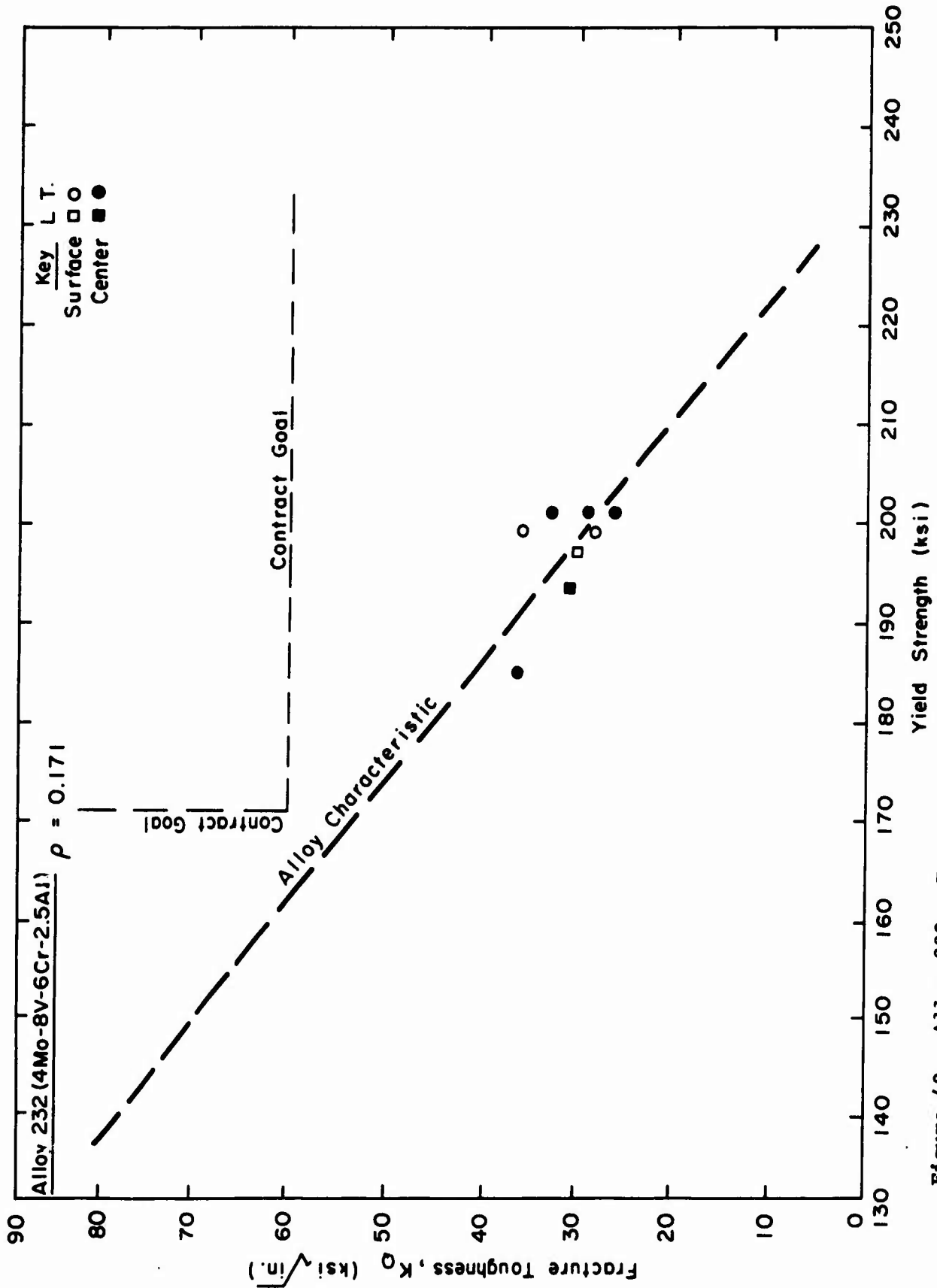

Figure 42 - Alloy 232. Fracture toughness-yield strength characteristic alloy trend lines. Defined using the data from Tables XX and XXI.

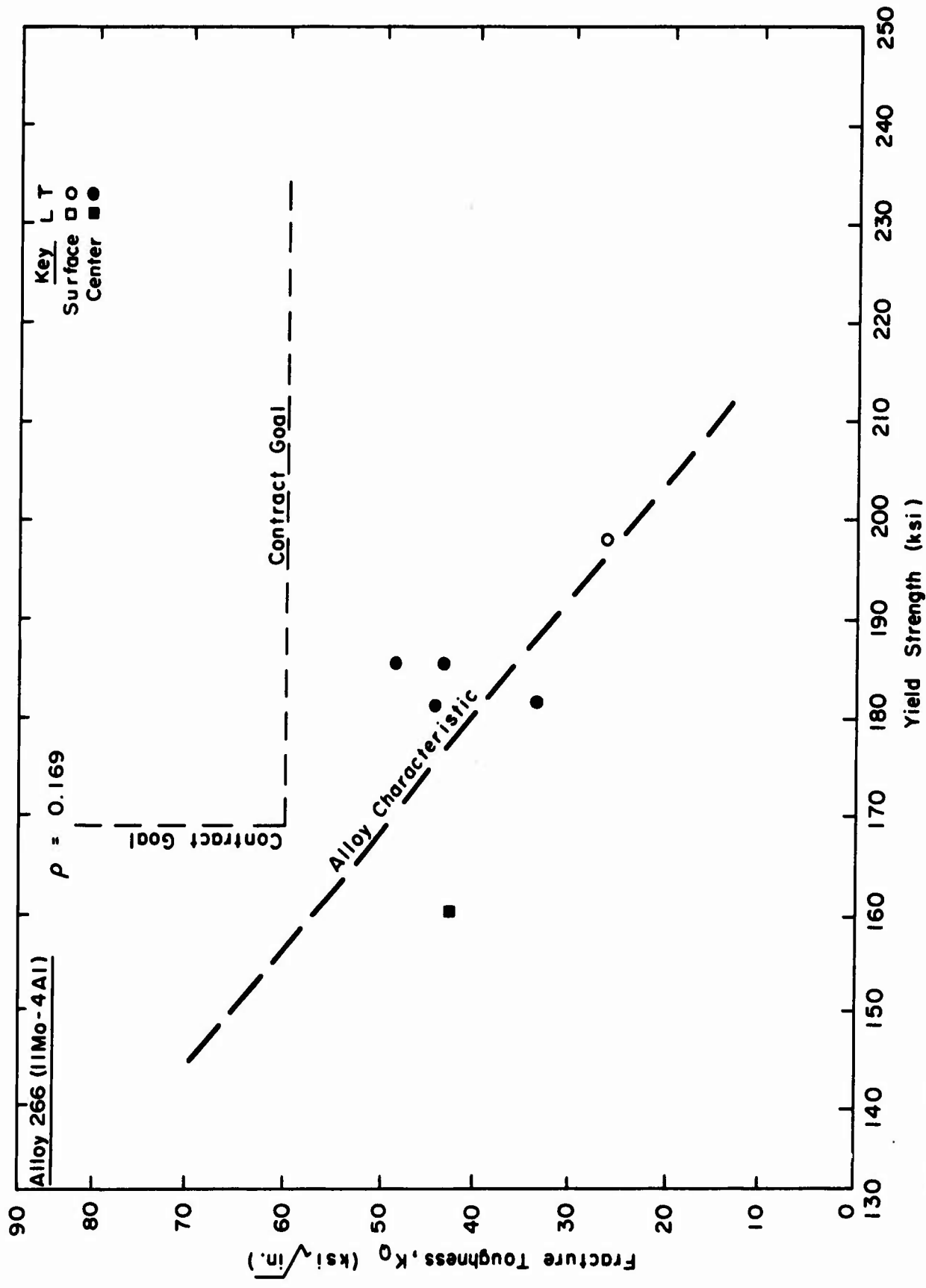

Figure 43 - Alloy 266. Fracture toughness-yield strength characteristic alloy trend lines. Defined using the data from Tables XX and XXI.

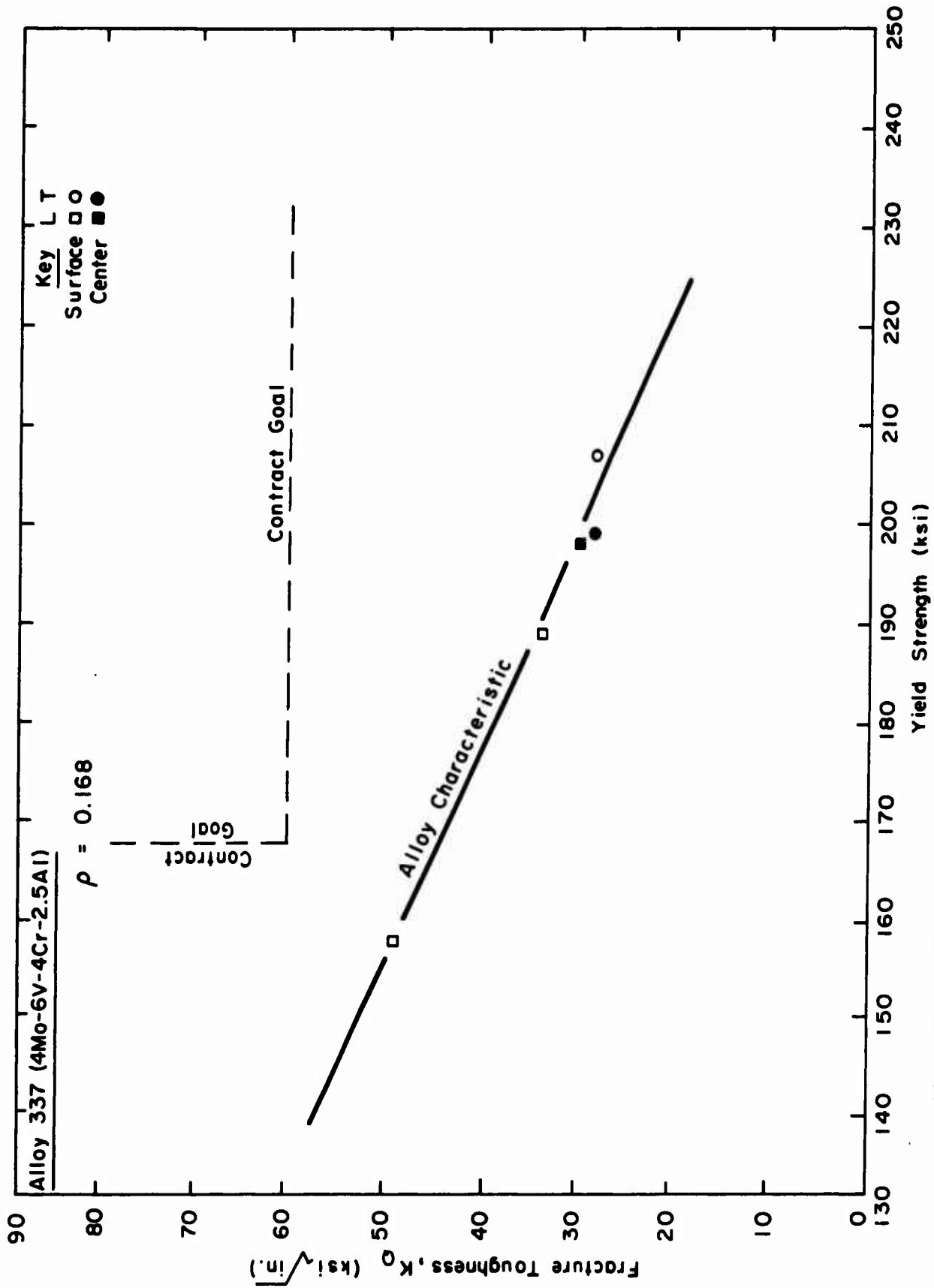

Figure 44 - Alloy 337. Fracture toughness-yield strength characteristic alloy trend lines. Defined using the data from Tables XX and XXI.

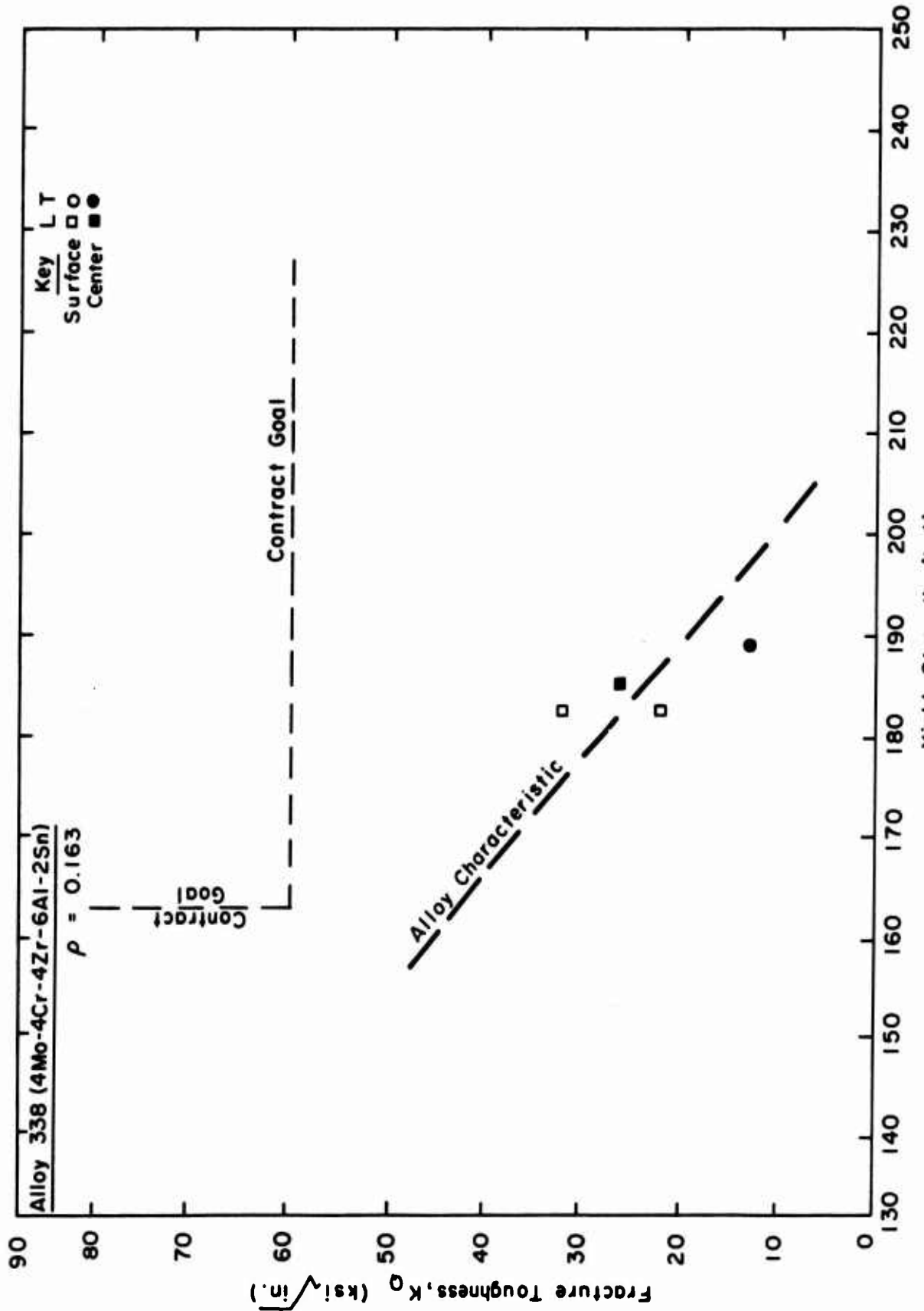

Figure 45 - Alloy 338. Fracture toughness-yield strength characteristic alloy trend lines. Defined using the data from Tables XX and XXI.

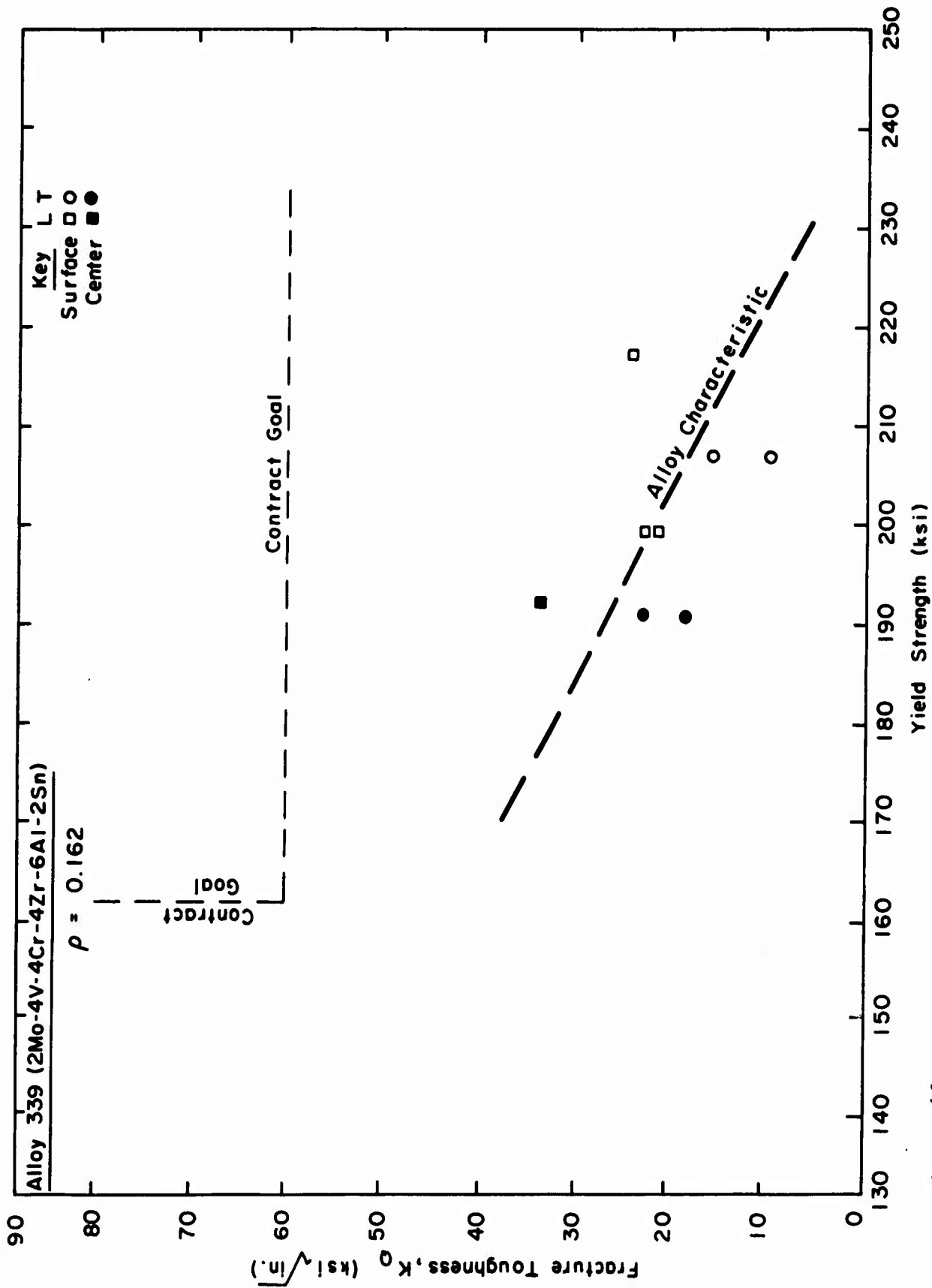

Figure 46 - Alloy 339. Fracture toughness-yield strength characteristic alloy trend lines. Defined using the data from Tables XX and XXI.

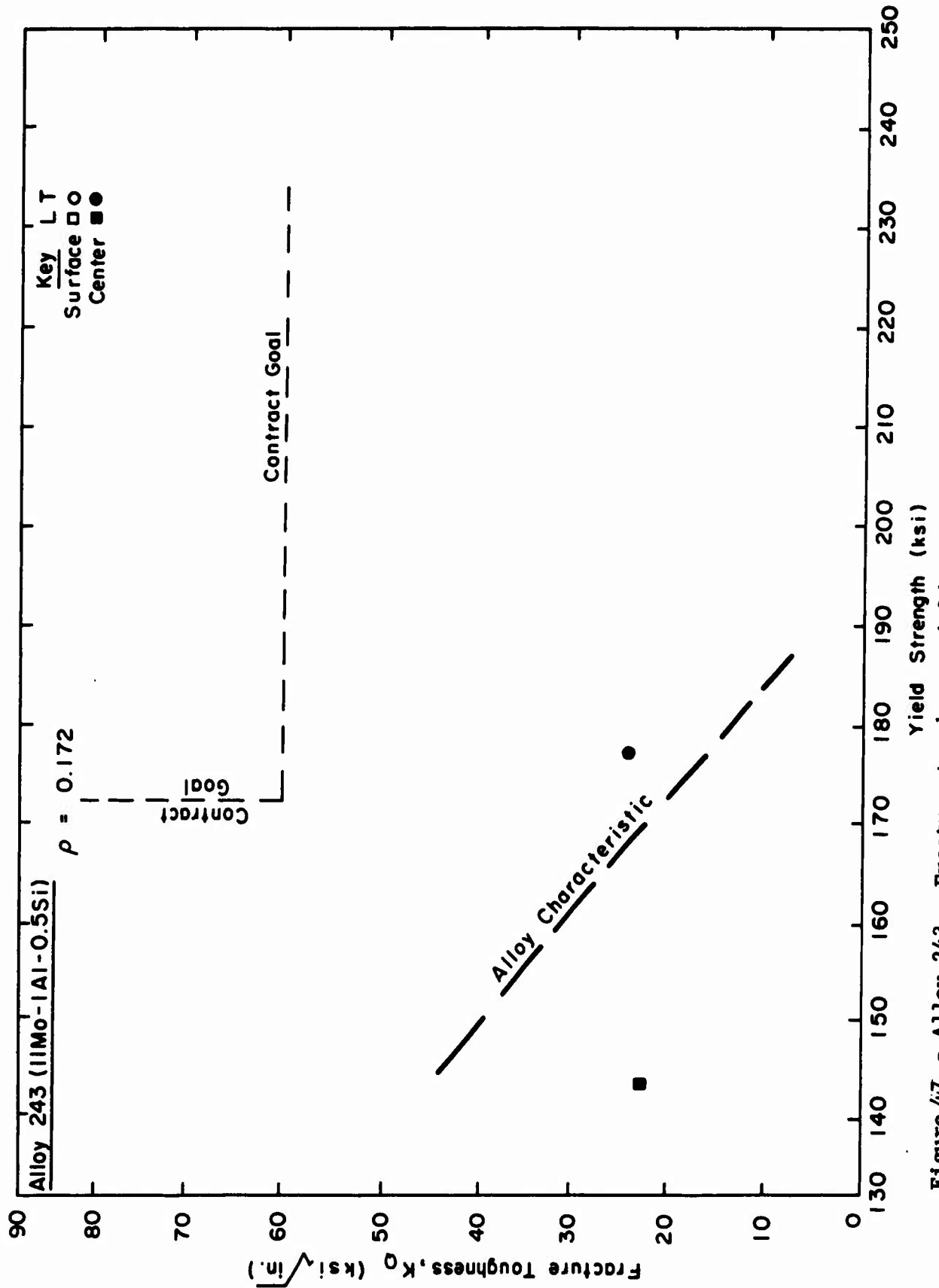

Figure 47 - Alloy 243. Fracture toughness-yield strength characteristic alloy trend lines. Defined using the data from Tables XX and XXI.

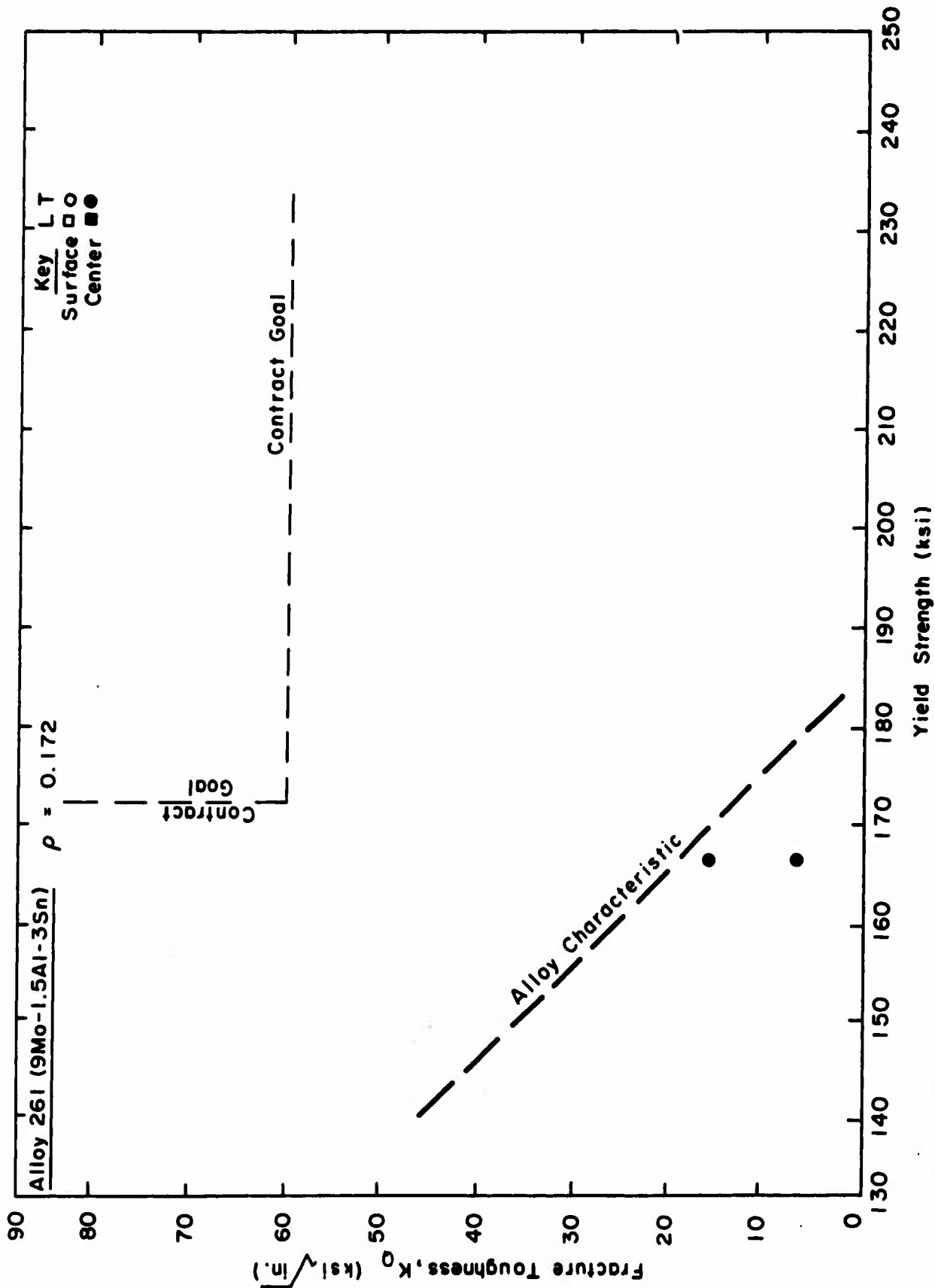

Figure 48 - Alloy 261. Fracture toughness-yield strength characteristic alloy trend lines. Defined using the data from Tables XX and XXI.

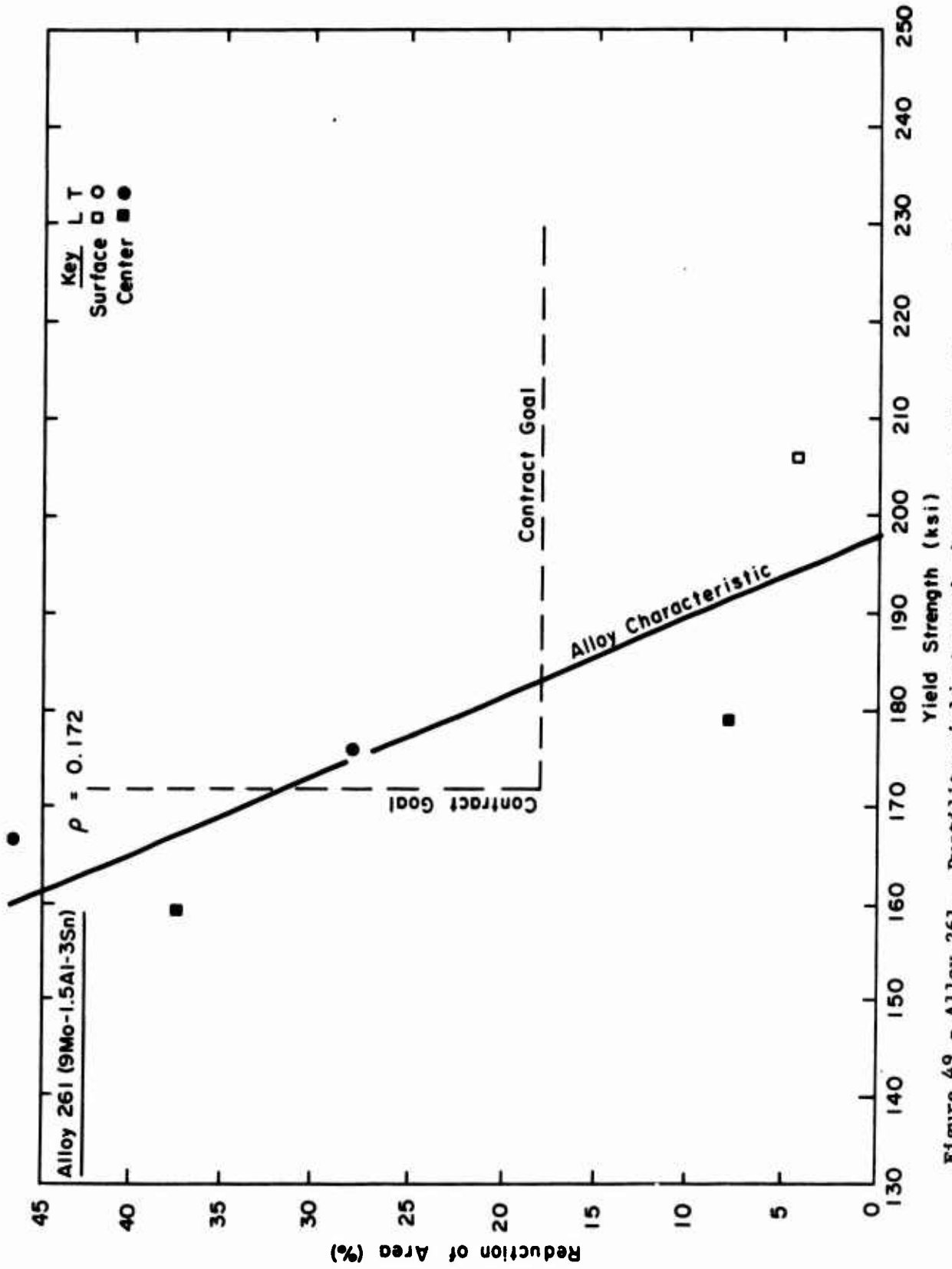

Figure 49 - Alloy 261. Ductility-yield strength characteristic alloy trend lines. Defined using the data from Tables XI and XXI.

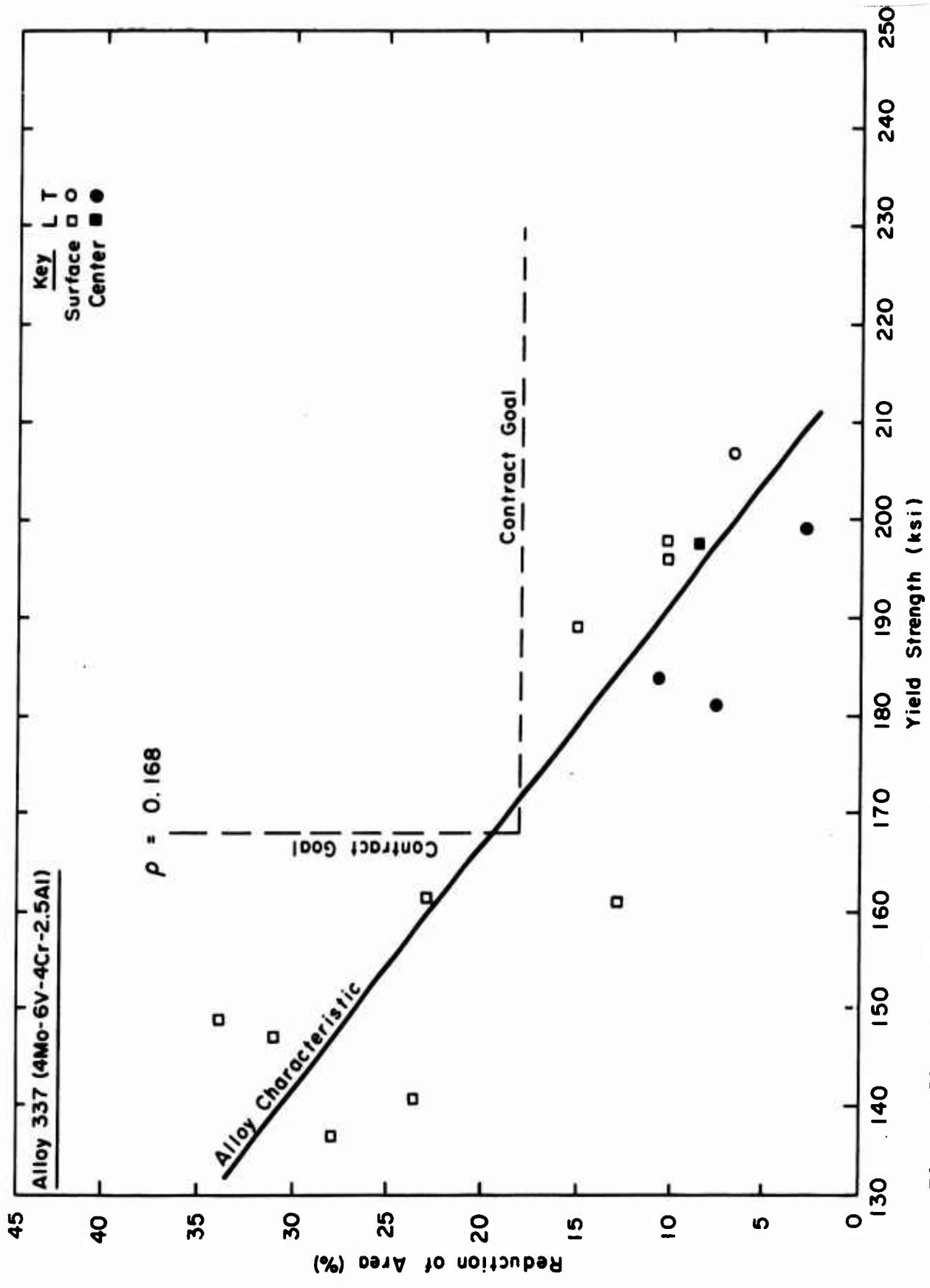

Figure 50- Alloy 337. Ductility-yield strength characteristic alloy trend lines. Defined using the data from Tables XX and XXI.

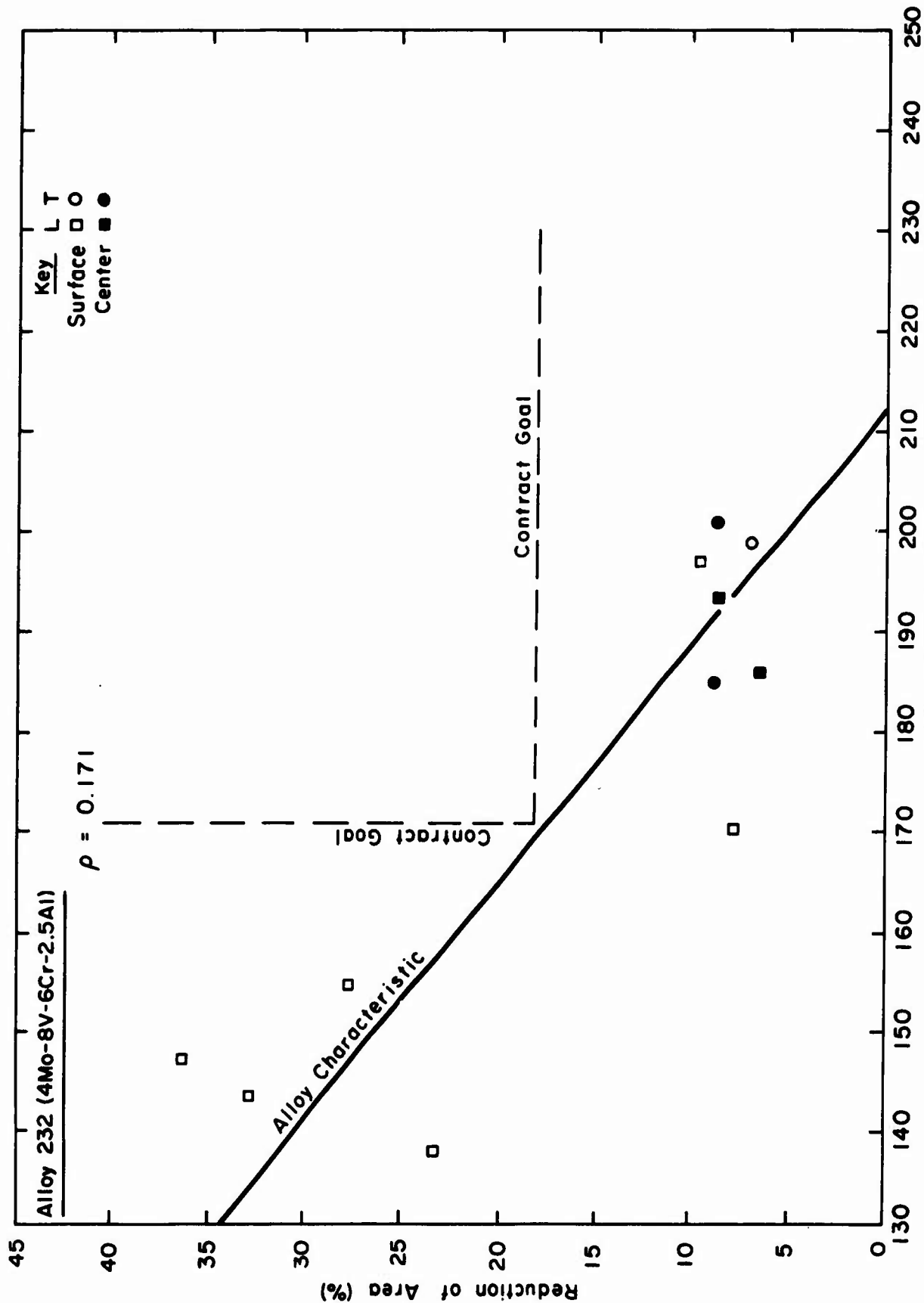

Figure 51 - Alloy 232. Ductility-yield strength characteristic alloy trend lines. Defined using the data from...

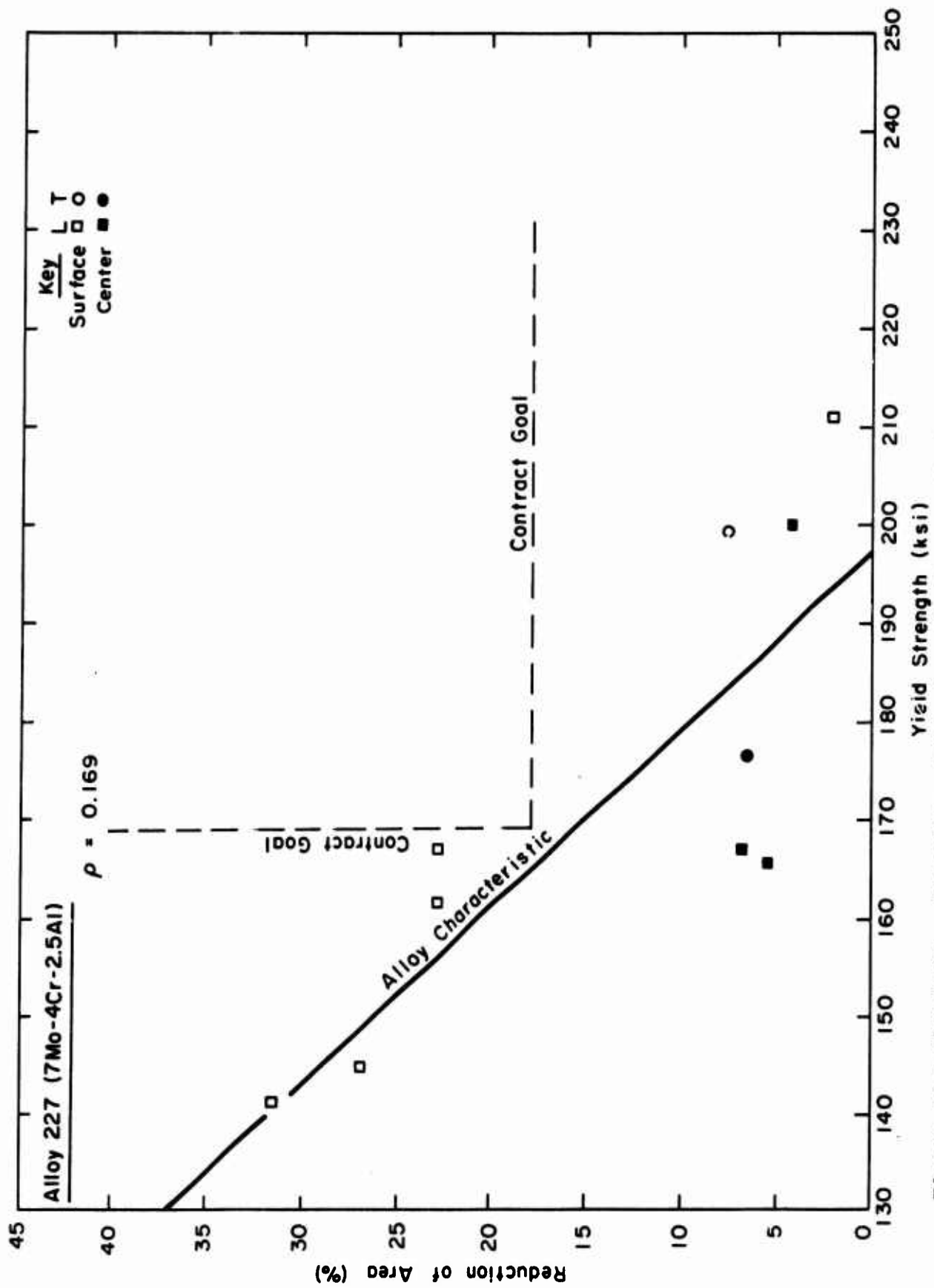

Figure 52 - Alloy 227. Ductility-yield strength characteristic alloy trend lines. Defined using the data from Tables XX and XXI.

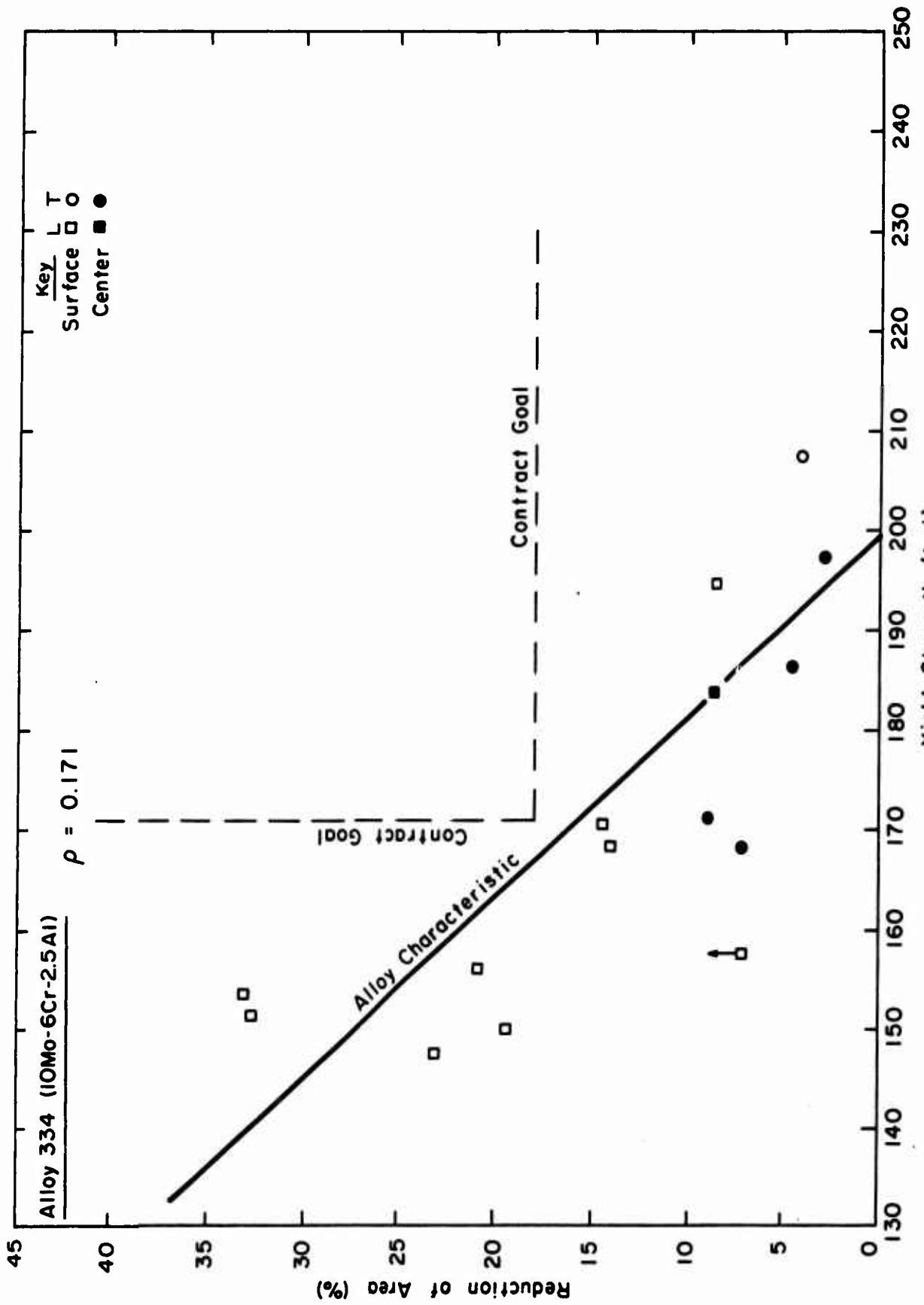

Figure 53 - Alloy 334. Ductility-yield strength characteristic alloy trend lines. Defined using the data from Tables XX and XXI.

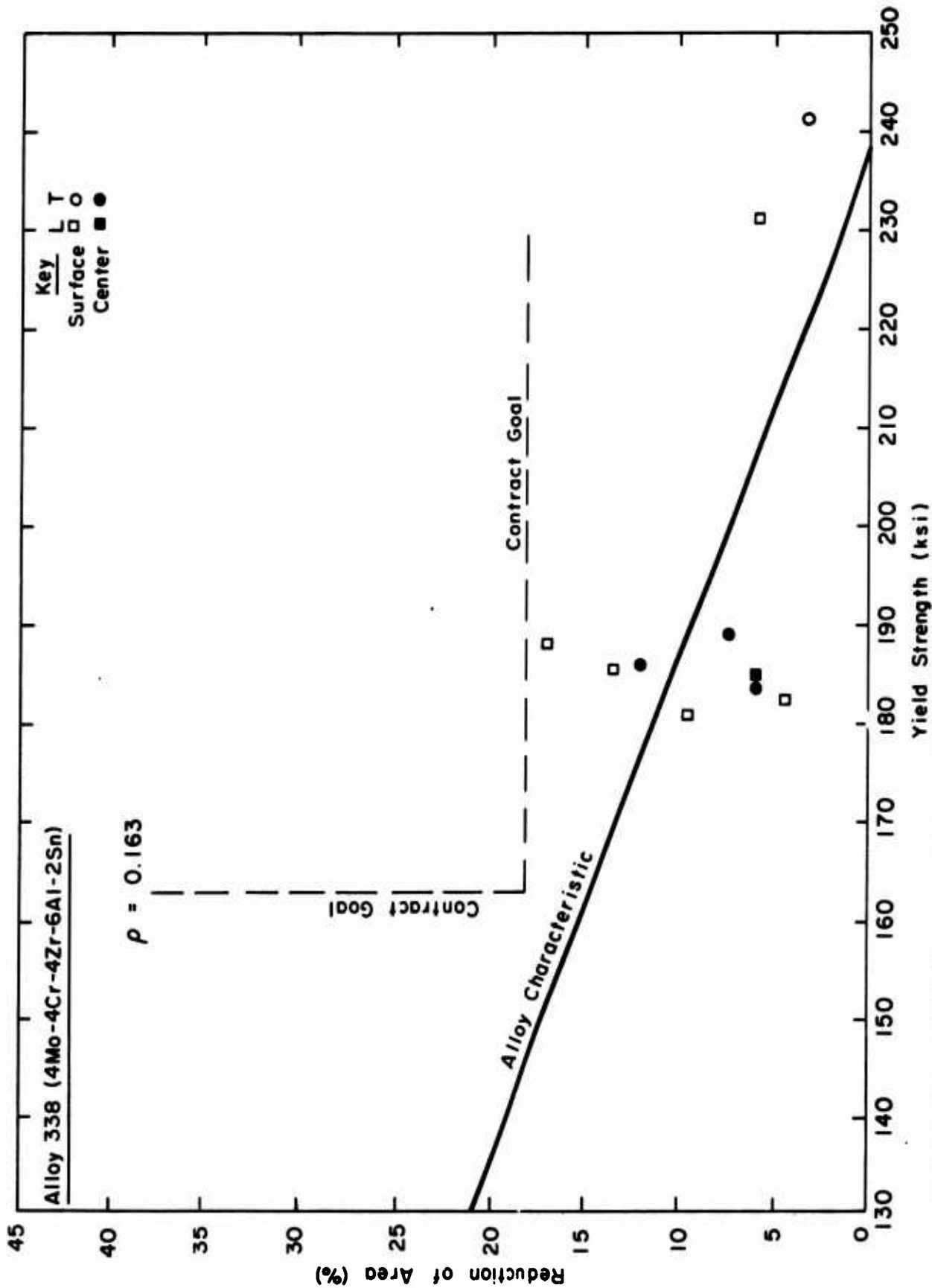

Figure 54 - Alloy 338. Ductility-yield strength characteristic alloy trend lines. Defined using the data from Tables XX and XXI.

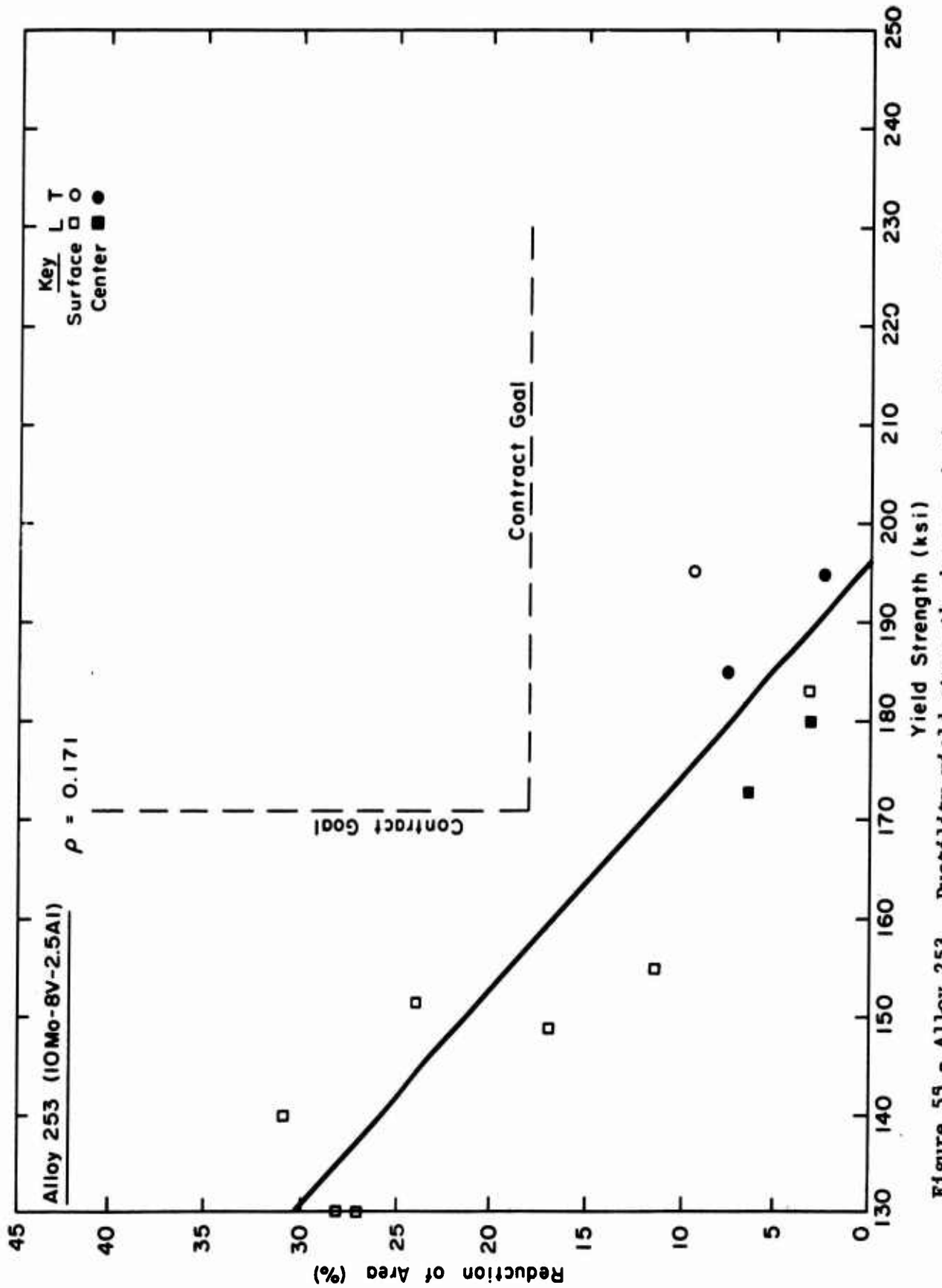

Figure 59 - Alloy 253. Ductility-yield strength characteristic alloy trend lines. Defined using the data from Tables XX and XXI.

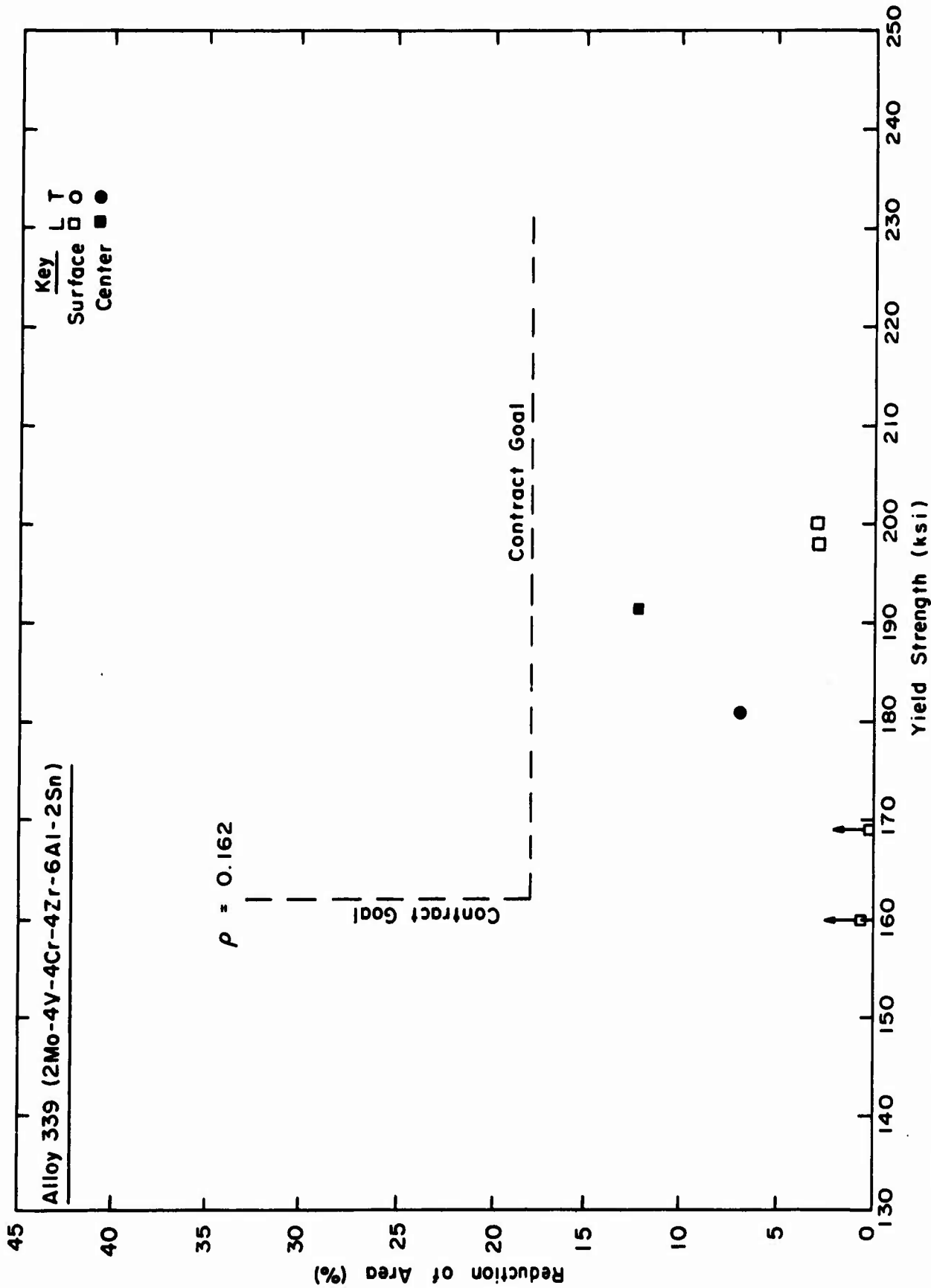

Figure 56 - Alloy 339. Ductility-yield strength characteristic alloy trend lines. Defined using the data from Tables XX and XXI.

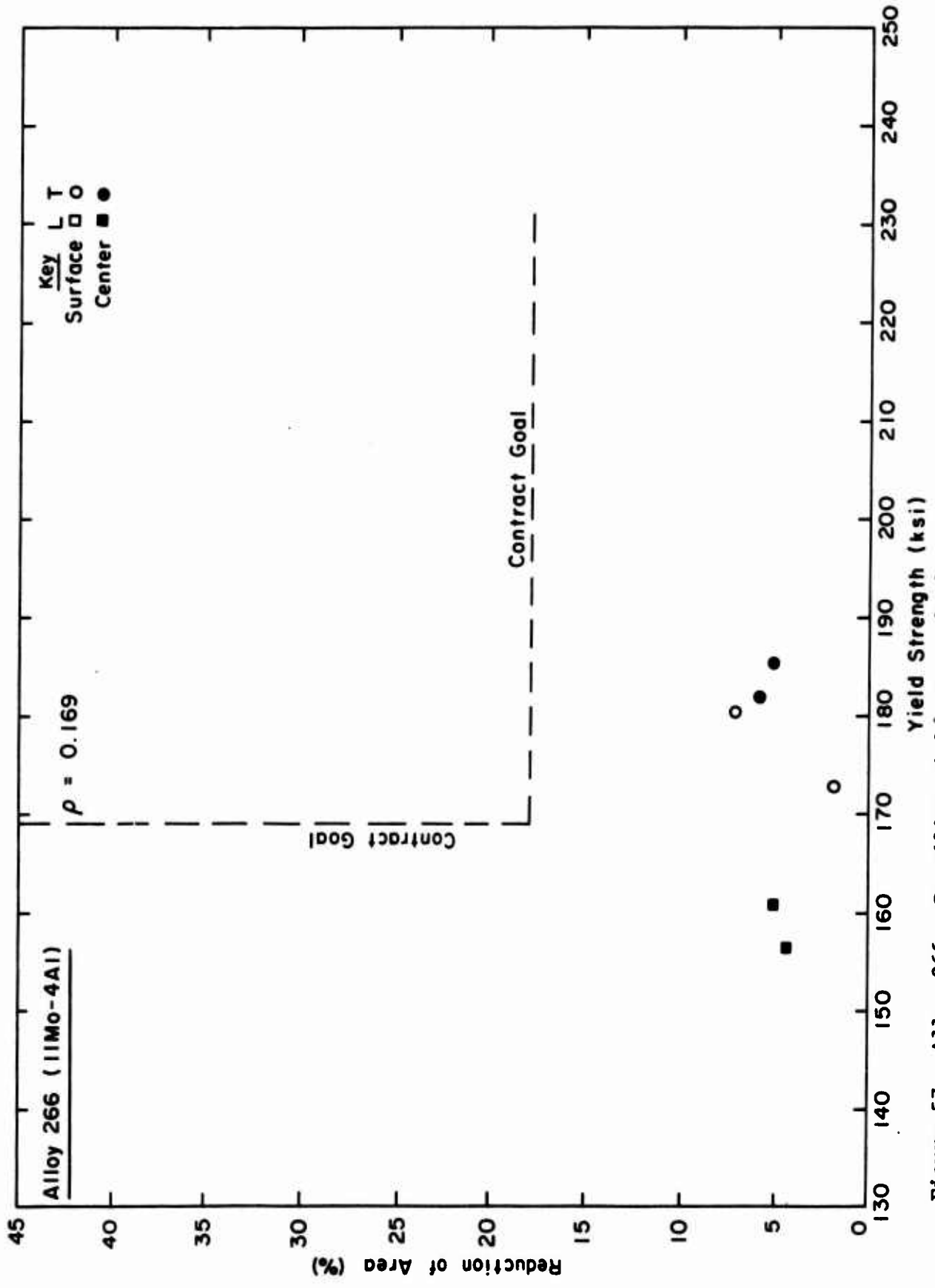

Figure 57 - Alloy 266. Ductility-yield strength characteristic alloy trend lines. Defined using the data from Tables XX and XXI.

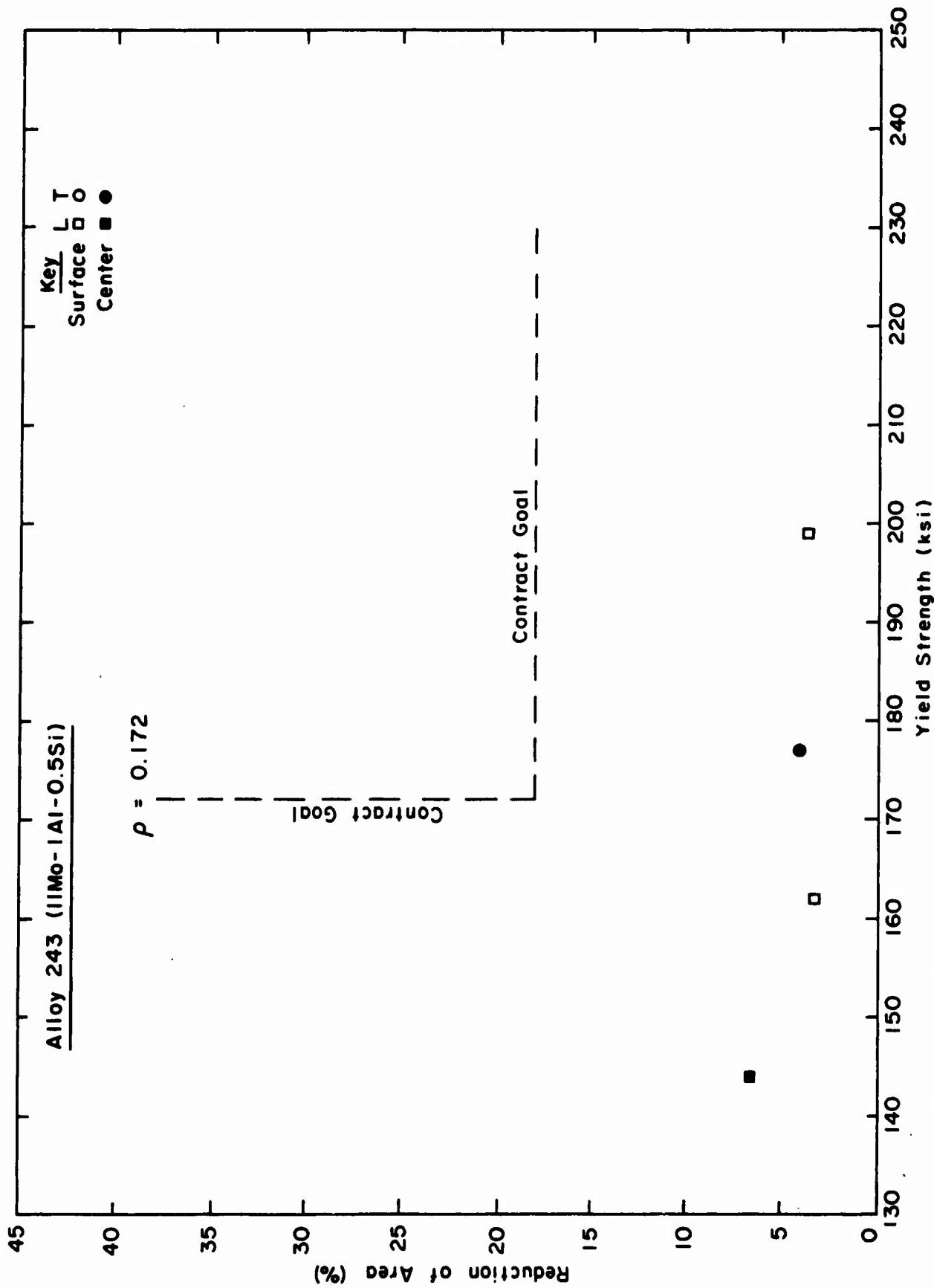
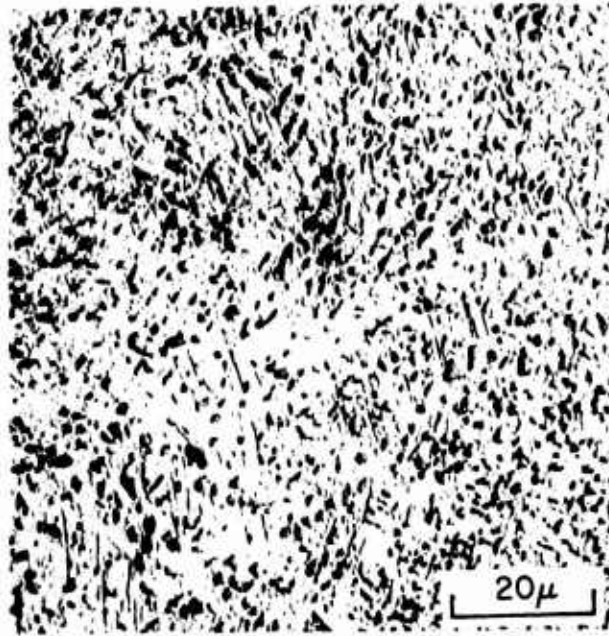

Figure 58 - Alloy 243 - Ductility-yield strength characteristic alloy trend lines. Defined using the data from Tables XX and XXI.



a



b

Fig. 59 - Microstructure as revealed by light microscopy in (a) Alloy 226 (12V-2.5Al) as solution treated and (b) Alloy 227 (7Mo-4Cr-2.5Al) as solution treated.

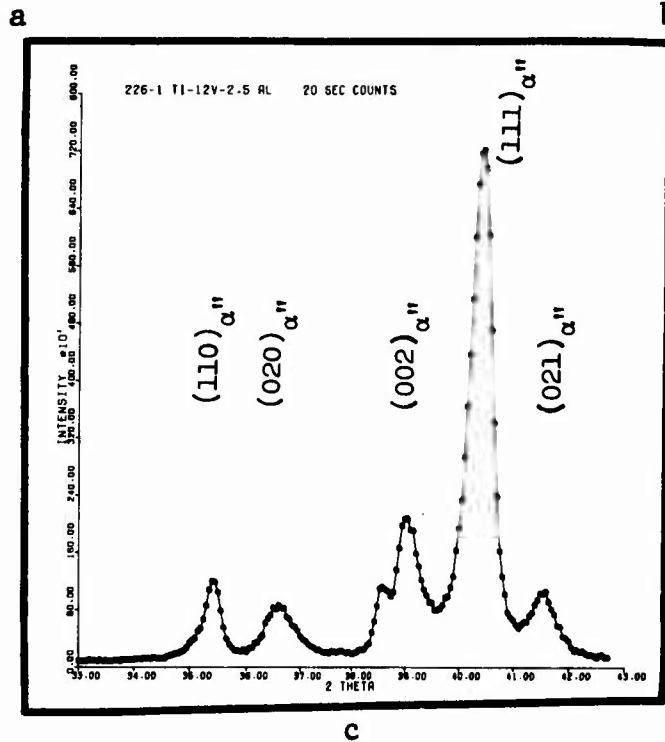
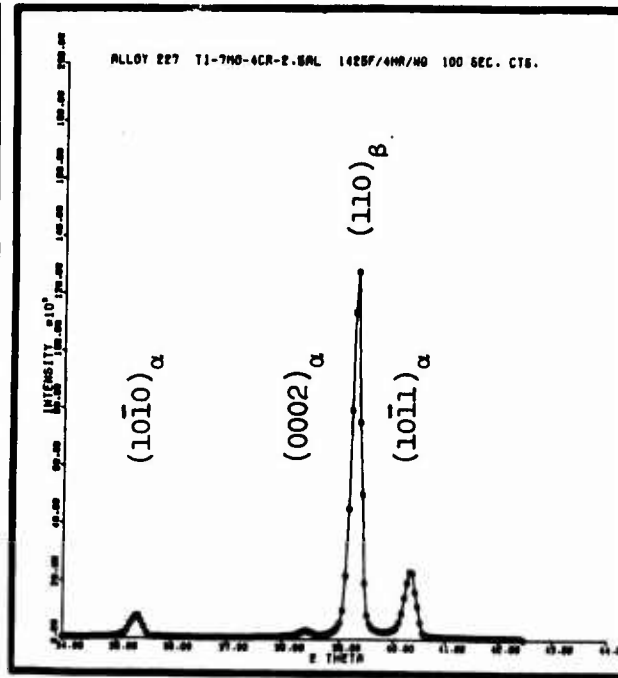
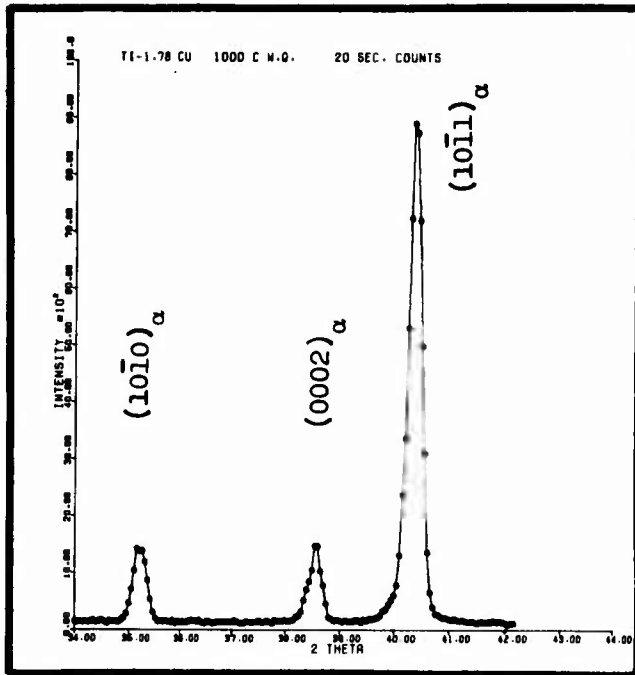
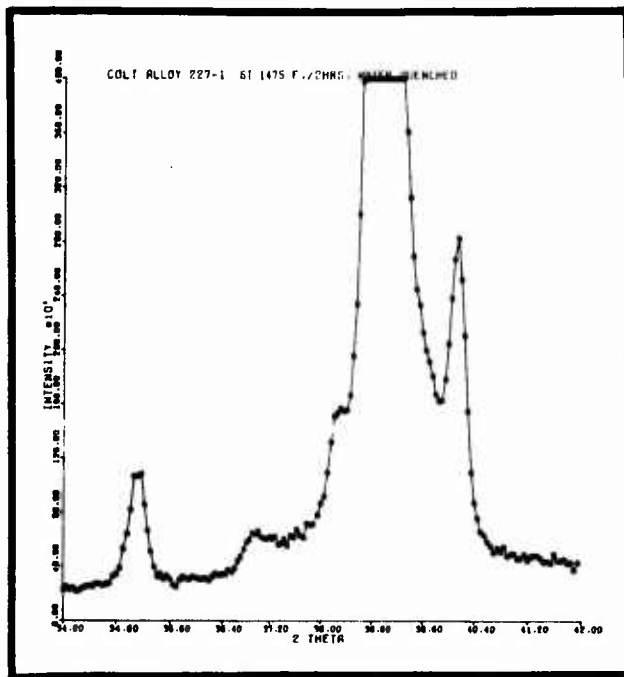

Fig. 60 - X-ray diffraction scans in the range of 34° - 40° 2θ from (a) hexagonal martensite or primary α ; (b) hexagonal martensite or primary α plus β ; (c) orthorhombic martensite (α'').



Fig. 61 - Transmission electron micrograph of Alloy 227 (7Mo-4Cr-2.5Al) as solution treated showing α'' which has spontaneously transformed to an fcc martensite during thinning.



a

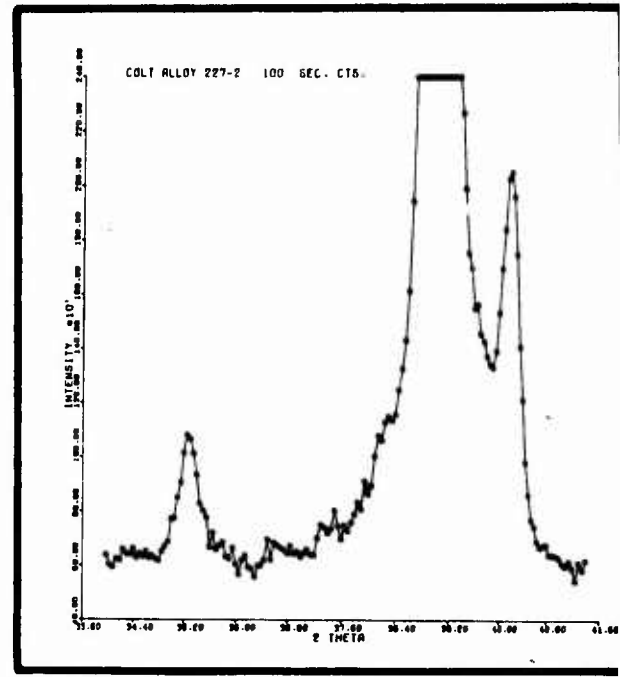

b

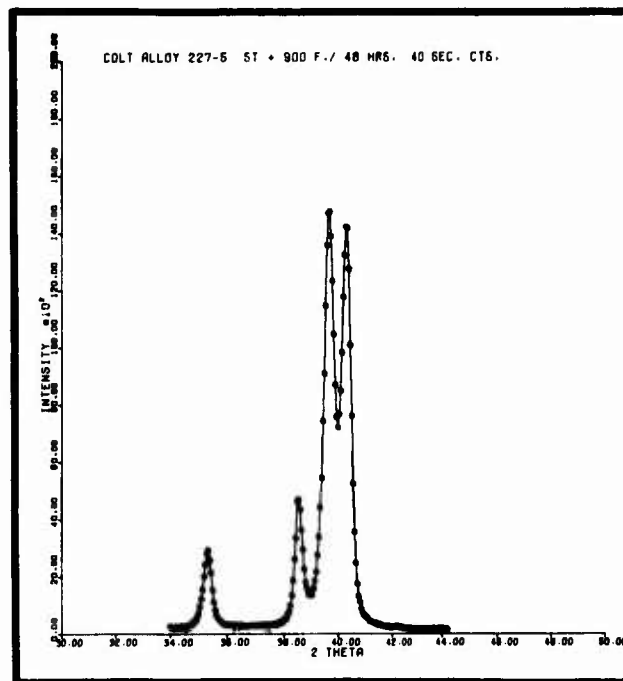

c

Fig. 62 - X-ray diffraction scans illustrating reversion of α'' to β during early stages of aging Alloy 227 (7Mo-4Cr-2.5Al). (a) α'' in as solution treated condition, (b) $\alpha+\beta$ in sample aged 1 minute at 900F, (c) $\alpha+\beta$ in sample aged 48 hours at 900F. Note increase in α -line intensity and change in β -line position due to alloy partitioning compared to sample aged for 1 minute.

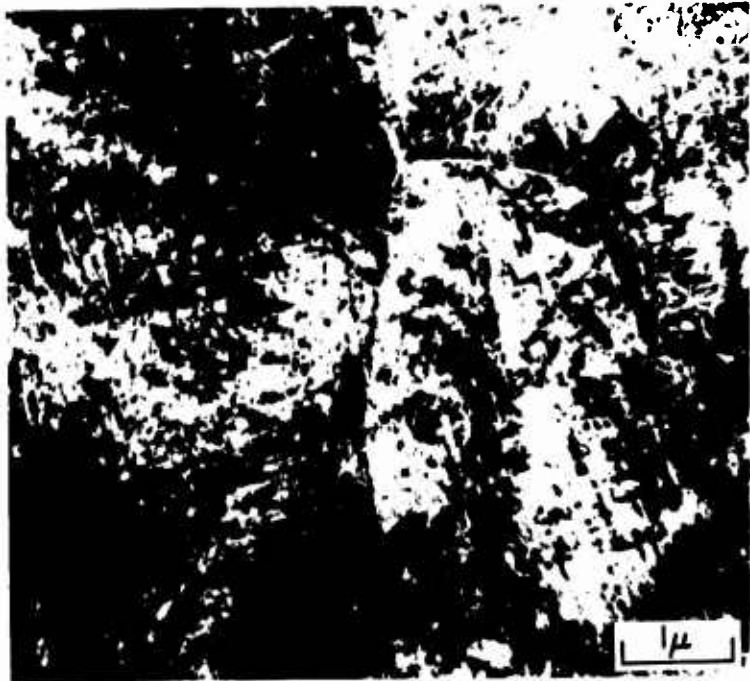
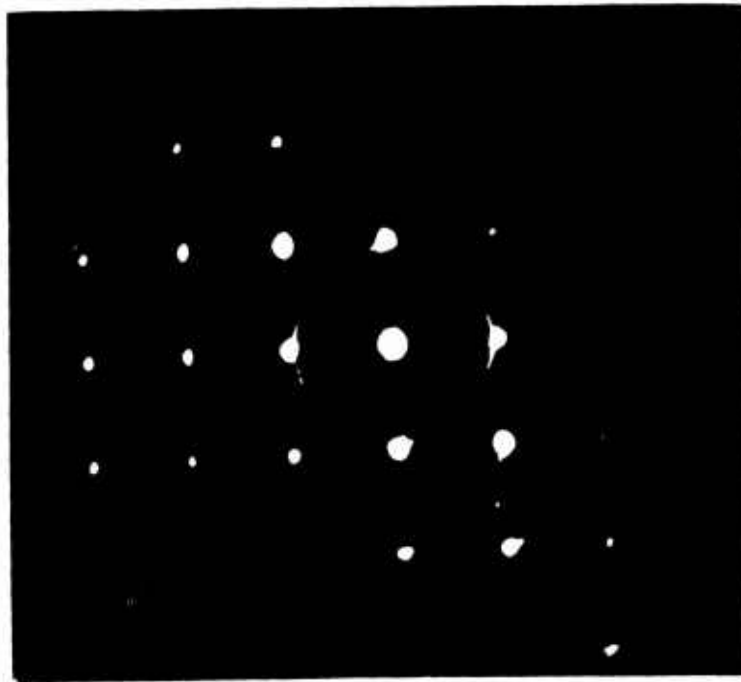
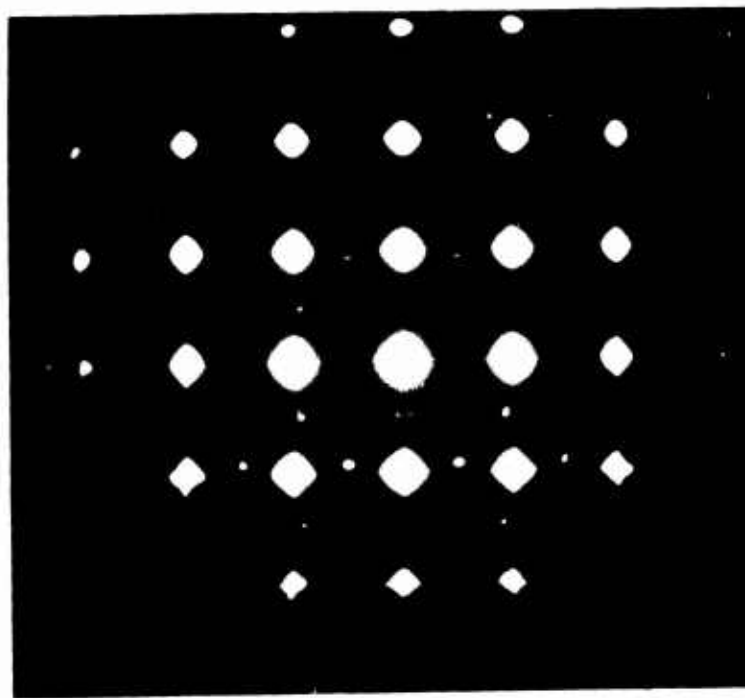

Fig. 63 - Transmission electron micrograph of Alloy 227 (7Mo-4Cr-2.5Al) solution treated and aged 6 minutes at 900F. Microstructure consists of α precipitates in β matrix.



a



b

Fig. 64 - Selected area diffraction patterns from TEM samples in which α -phase has precipitated in a beta matrix. (a) $[100]_{\beta}$ zone in Alloy 227 (7Mo-4Cr-2.5Al) solution treated and aged 8 hours at 900F; (b) $[100]_{\alpha}$ zone in Ti alloy in which Burgers orientation relation between α and β phases exists.

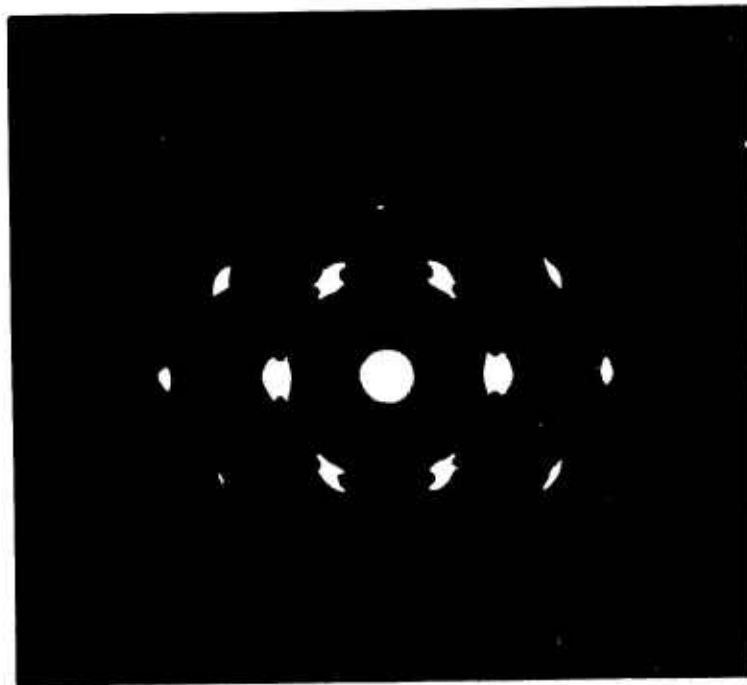

c

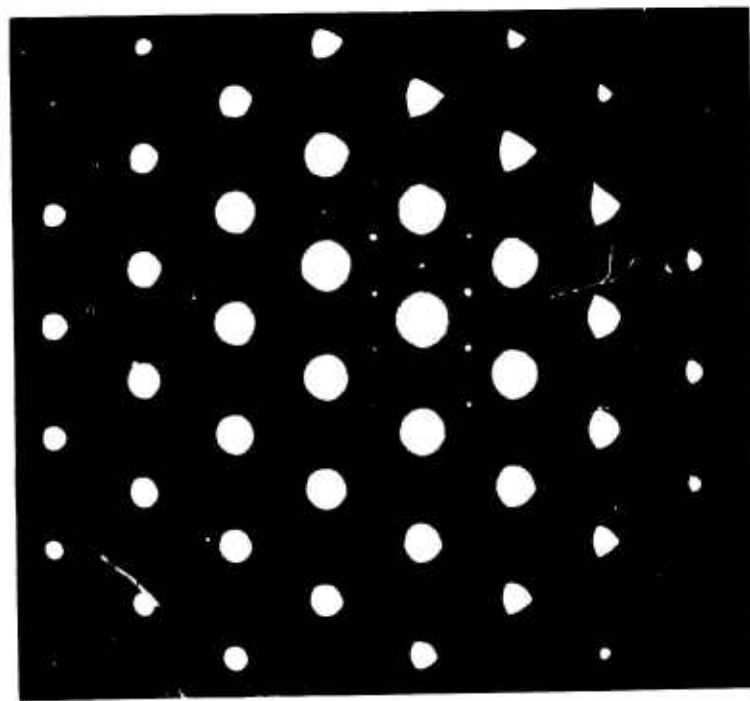

d

Fig. 64 - Selected area diffraction patterns from TEM samples in which α -phase has precipitated in a beta matrix. (c) $[111]_{\beta}$ zone in Alloy 227 (7Mo-4Cr-2.5Al) solution treated and aged 8 hrs at 900F; and (d) $[111]_{\beta}$ zone in Ti alloy in which Burgers orientation relation exists.

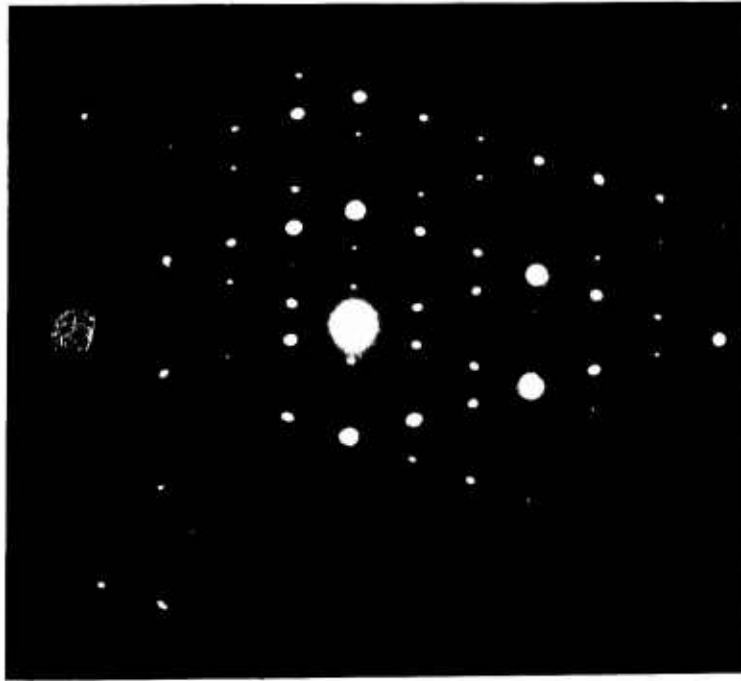

a

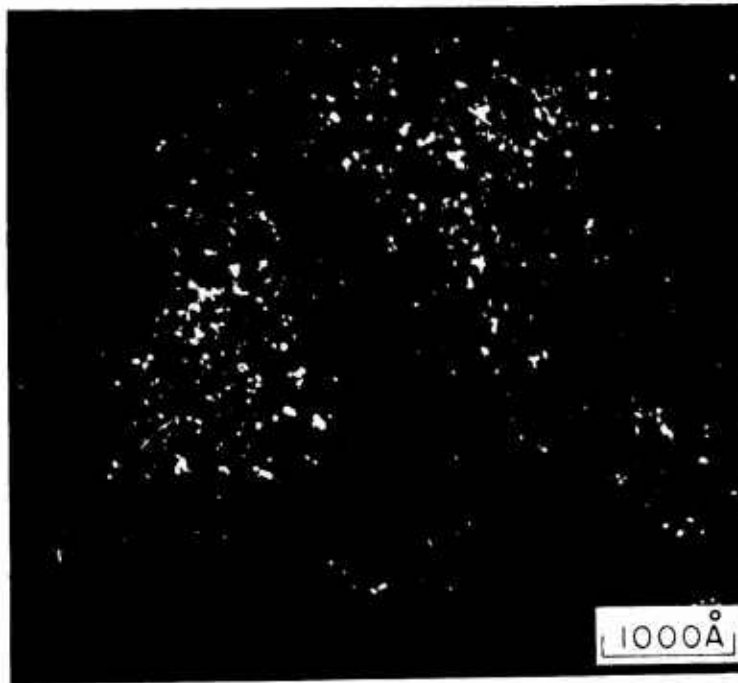

b

Fig. 65 - Athermal omega phase in solution treated Alloy 240 (6Mo-6V) as revealed by TEM. (a) SAD pattern showing superimposed $[113]_{\omega}$ zone and two $[1120]_{\omega}$ zones; (b) dark field electron micrograph with $[1011]_{\omega}$ reflection operating.

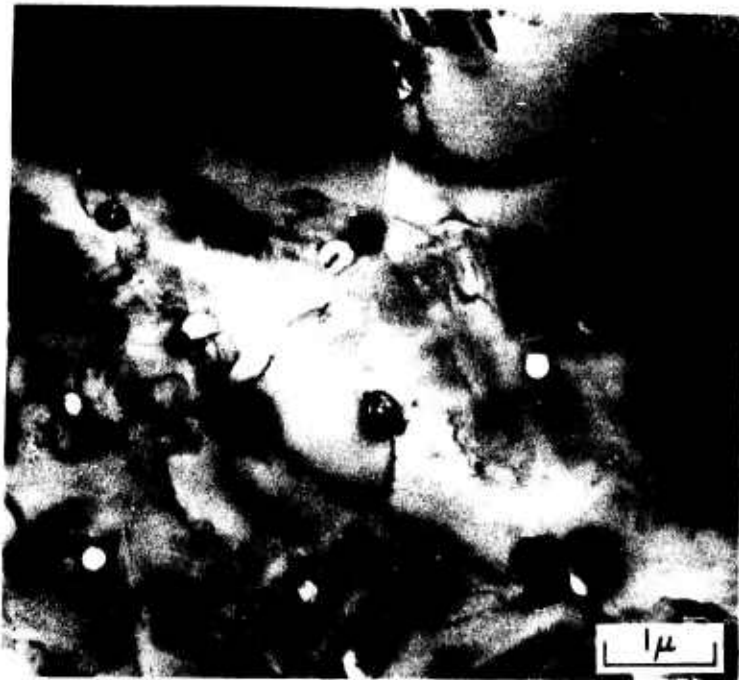

Fig. 66 - Transmission electron micrograph of solution treated Alloy 243 (11Mo-1Al-0.5Si) showing primary α and Ti_5Si_3 particles.

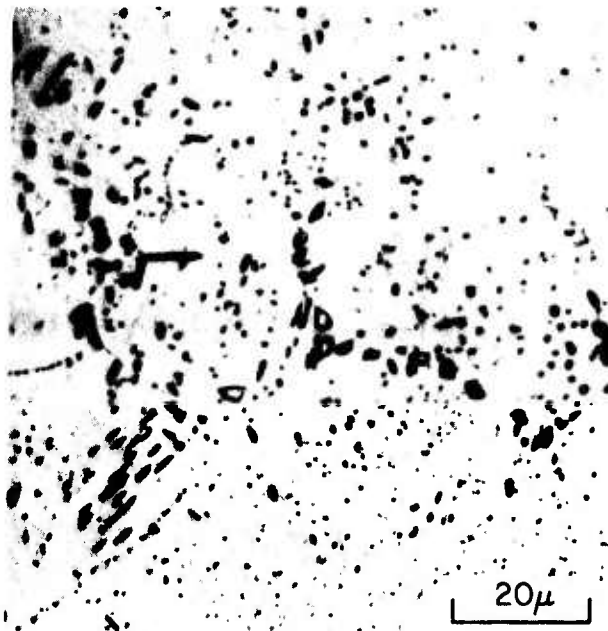

Fig. 67 - Light micrograph of solution treated Alloy 243 (11Mo-1Al-0.5Si) illustrating similarity in size of Ti_5Si_3 and primary α particles.

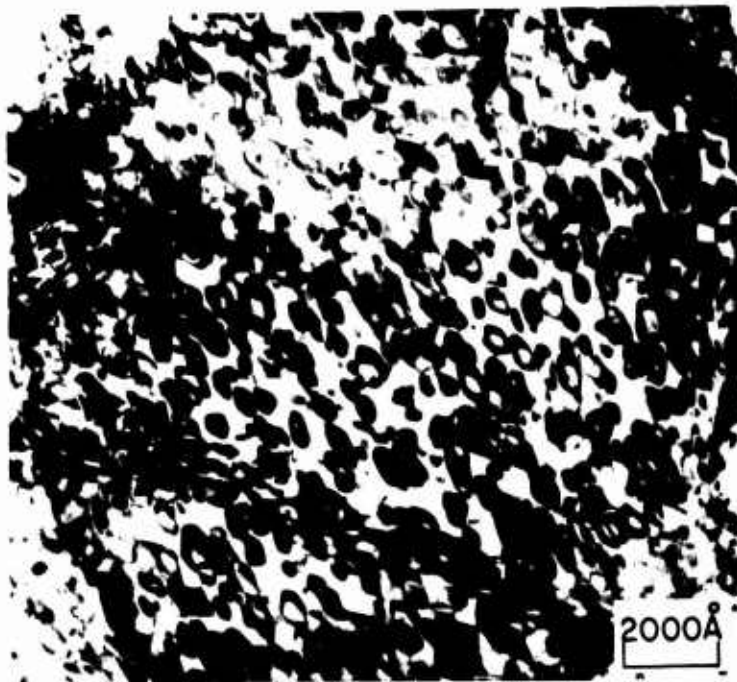

Fig. 68 - Ellipsoidal omega particles in Alloy 240 (6Mo-6V) solution treated and aged 8 hrs at 800F as revealed by transmission-electron microscopy.

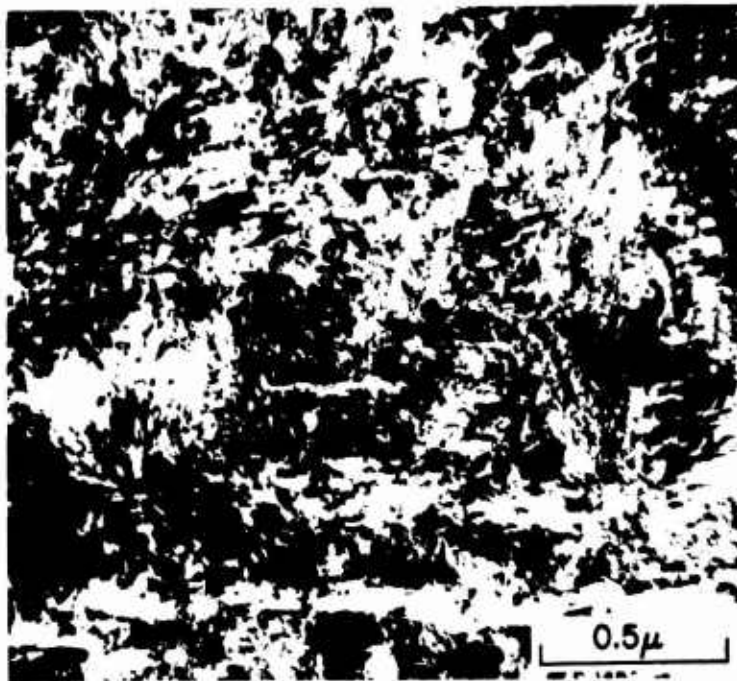

Fig. 69 - Transmission electron micrograph of Alloy 243 (11Mo-1Al-0.5Si) solution treated and aged 8 hrs at 950F showing α -phase precipitation in δ matrix.



Fig. 70 Transmission micrograph of Alloy 266 (11Mo-4Al) as solution treated revealing sub-grain structure in β matrix.

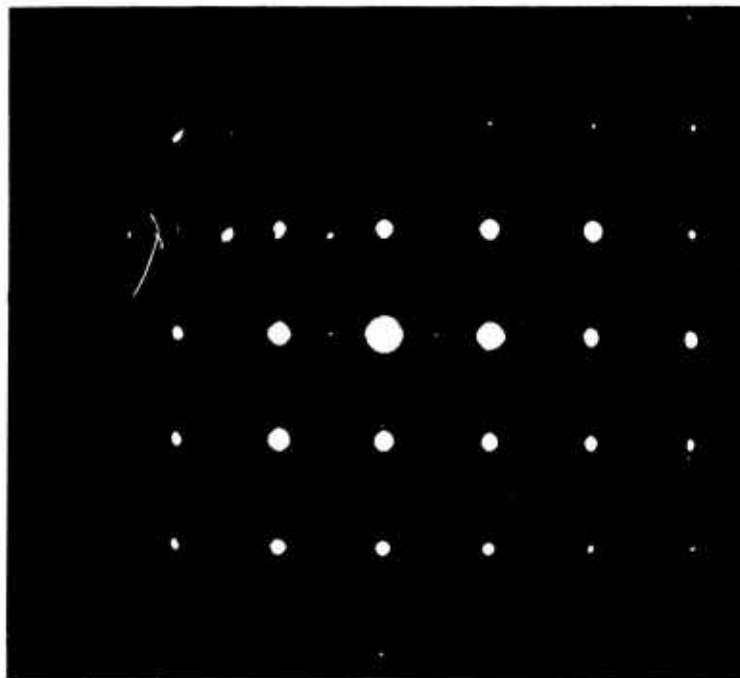
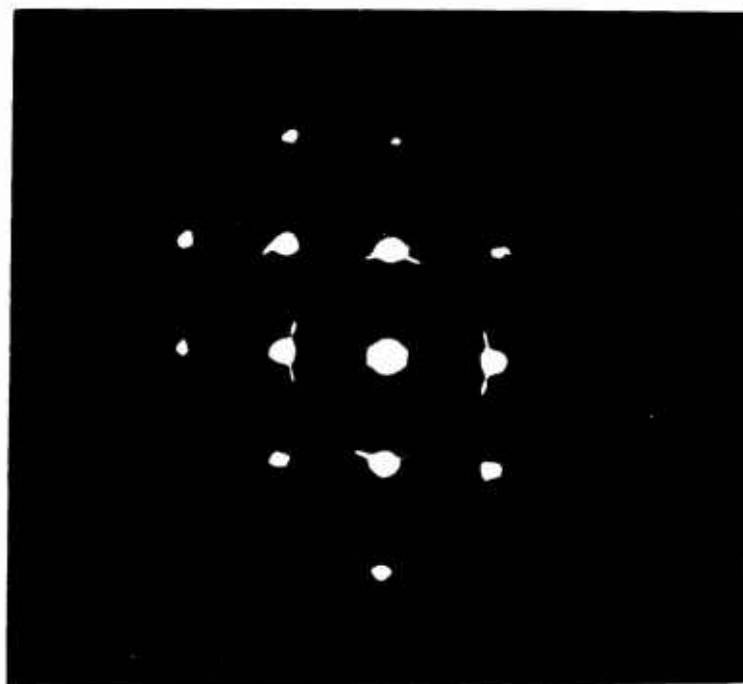

Fig. 71 - Selected area electron diffraction pattern in Alloy 266 indicating grain boundary α -phase precipitate has Burgers orientation relation with β matrix.



a



b

Fig. 72 Alloy 266 (11Mo-4Al) solution treated and aged 2 minutes at 1000F. (a) Transmission electron micrograph revealing high density of α precipitates; (b) selected area electron diffraction pattern indicating α -precipitates do not have Burgers orientation relation with β matrix.



a

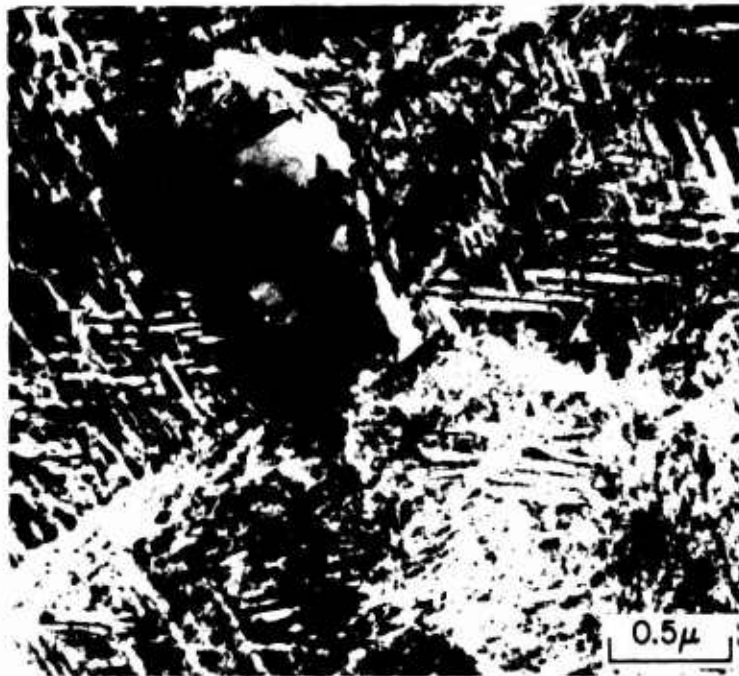

b

Fig. 73 - Transmission electron micrographs of Alloy 266 (11Mo-4Al) solution treated and aged at 1000F illustrating agglomeration of α -phase precipitates. (a) 8 hour age, dark field micrograph with $(10\bar{1}0)_\alpha$ reflection operating, and (b) 48 hour age, bright field micrograph.

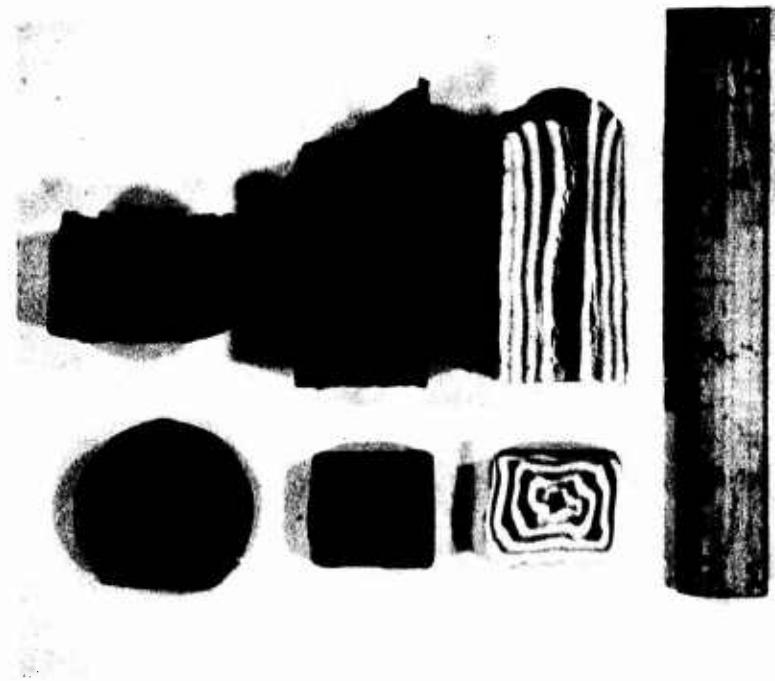

Figure 74. Simulation of Phase III forging using plasticine "swiss-rolls". (Left) "Swiss-roll" compiled from two different colored strands of plasticine. (Middle) "Swiss-roll" after simulated tri-directional forging sequence (Figure 75). (Right) "Swiss-roll" after simulated uni-directional forging sequence. Longitudinal cross-section is shown at the top and transverse cross-section at the bottom in each case. Note increased distortion of plasticine in the center of the "Swiss-roll" after tri-directional working.

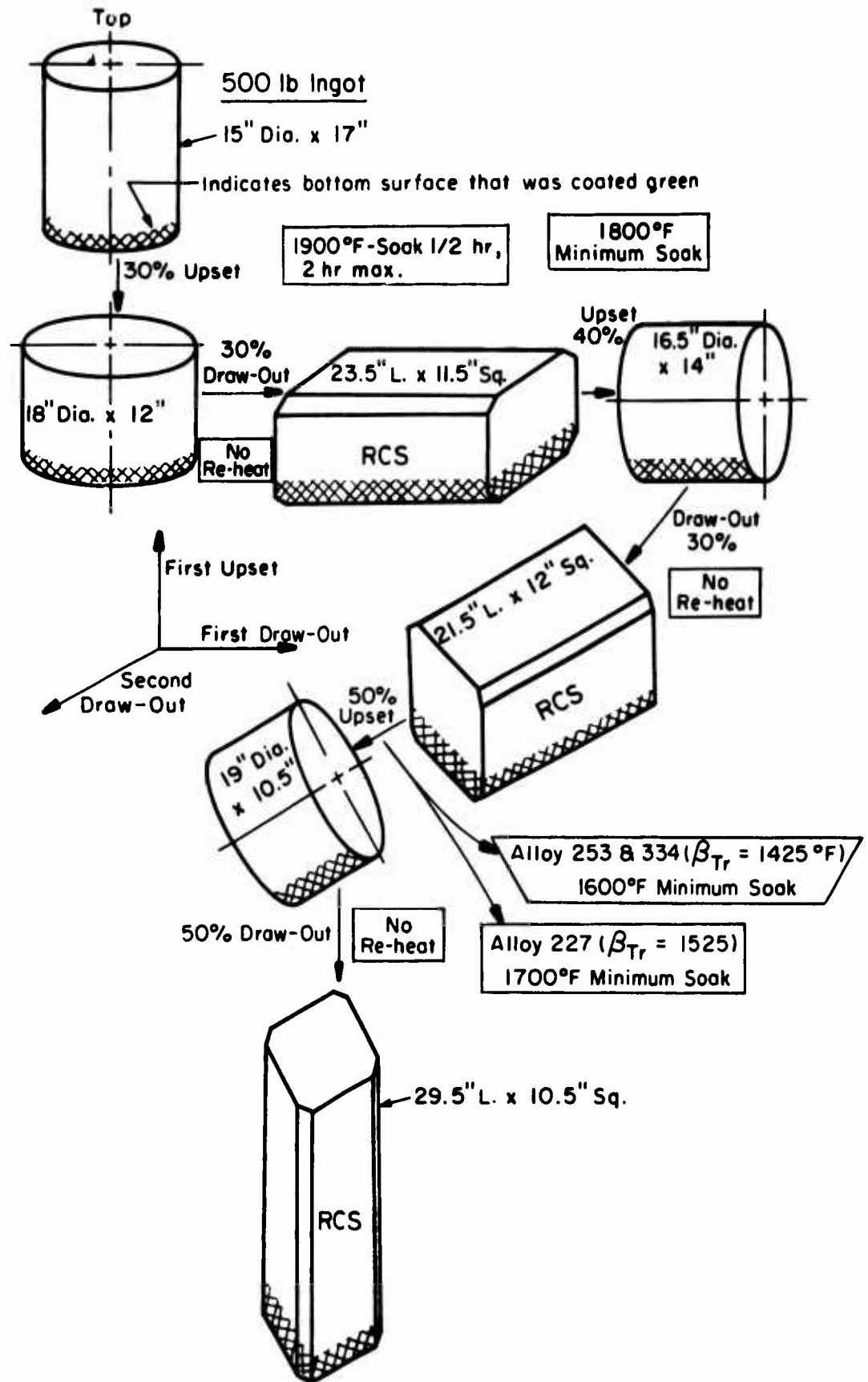
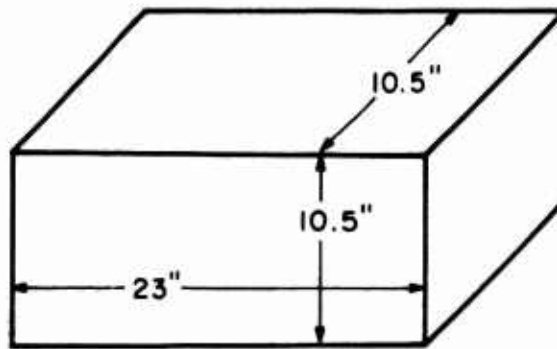

Figure 75. Tri-directional (three directions mutually at right angles) primary forging sequence used to convert ingots to 10.5 inch RCS bloom.

Full 10.5-Inch RCS Bloom



30% Upset
➔
plus
Draw-Out

6.5-Inch RCS
x Length

Test Piece

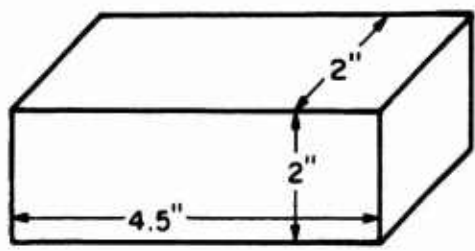

30% Upset
➔
plus Draw-Out

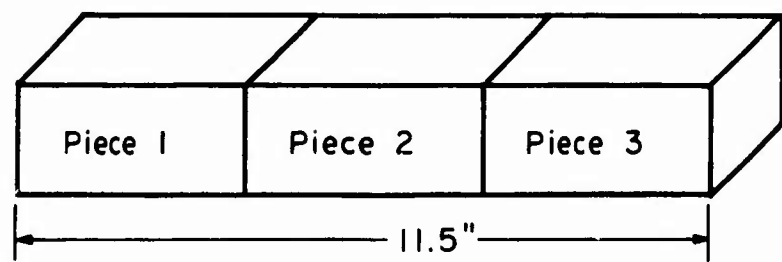

1.25-Inch RCS

Note : Each piece contains sufficient material for two tensile and two charpy specimen sample.

Figure 76. Schematic illustration of conversion of full sized 10.5 mil RCS bloom to 6 inch diameter billet and corresponding samples used to simulate this processing sequence.

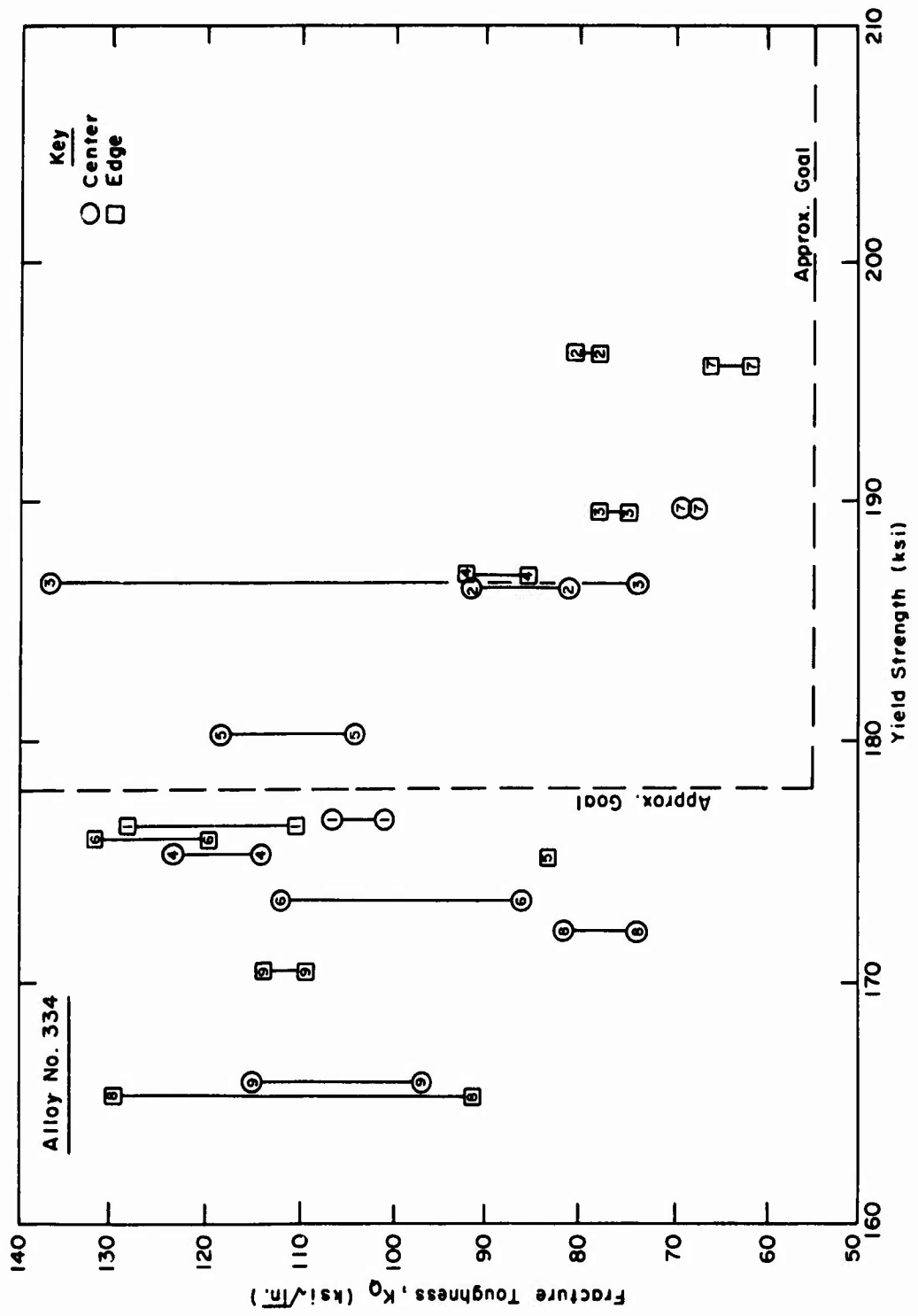

Figure 77. Alloy 334 (10Mo-6Cr-2.5Al). Comparison of yield strength - toughness after the various TMT sequences defined in Tables XXVIII and XLII. Treatments corresponding to the various codes are defined in the referenced Tables.

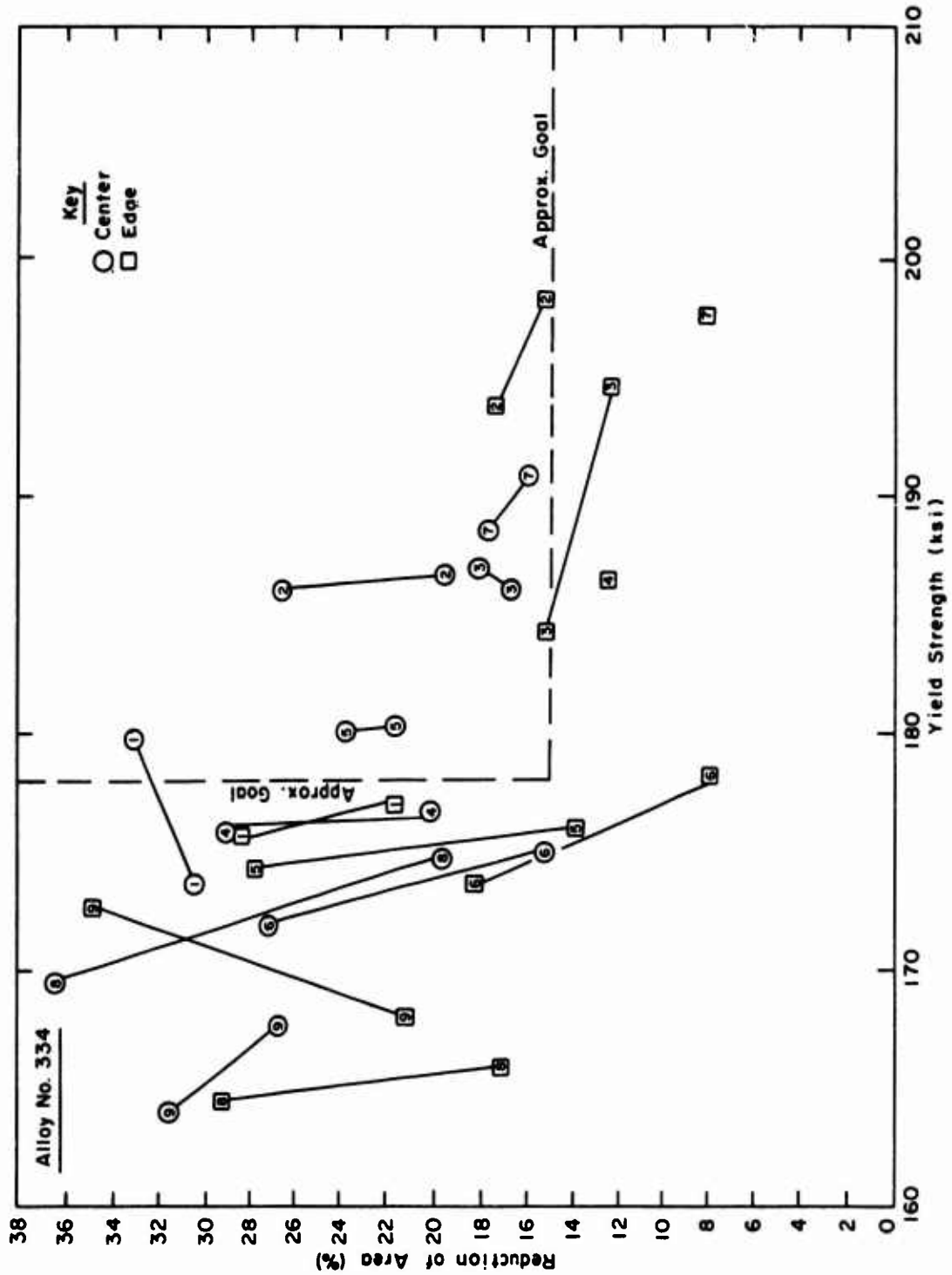

Figure 78. Alloy 334 (10Mo-6Cr-2.5Al). Comparison of yield strength - reduction of area after the various TMT sequences defined in Tables XXVIII and XLII. Treatments corresponding to the various codes are defined in the referenced Tables.

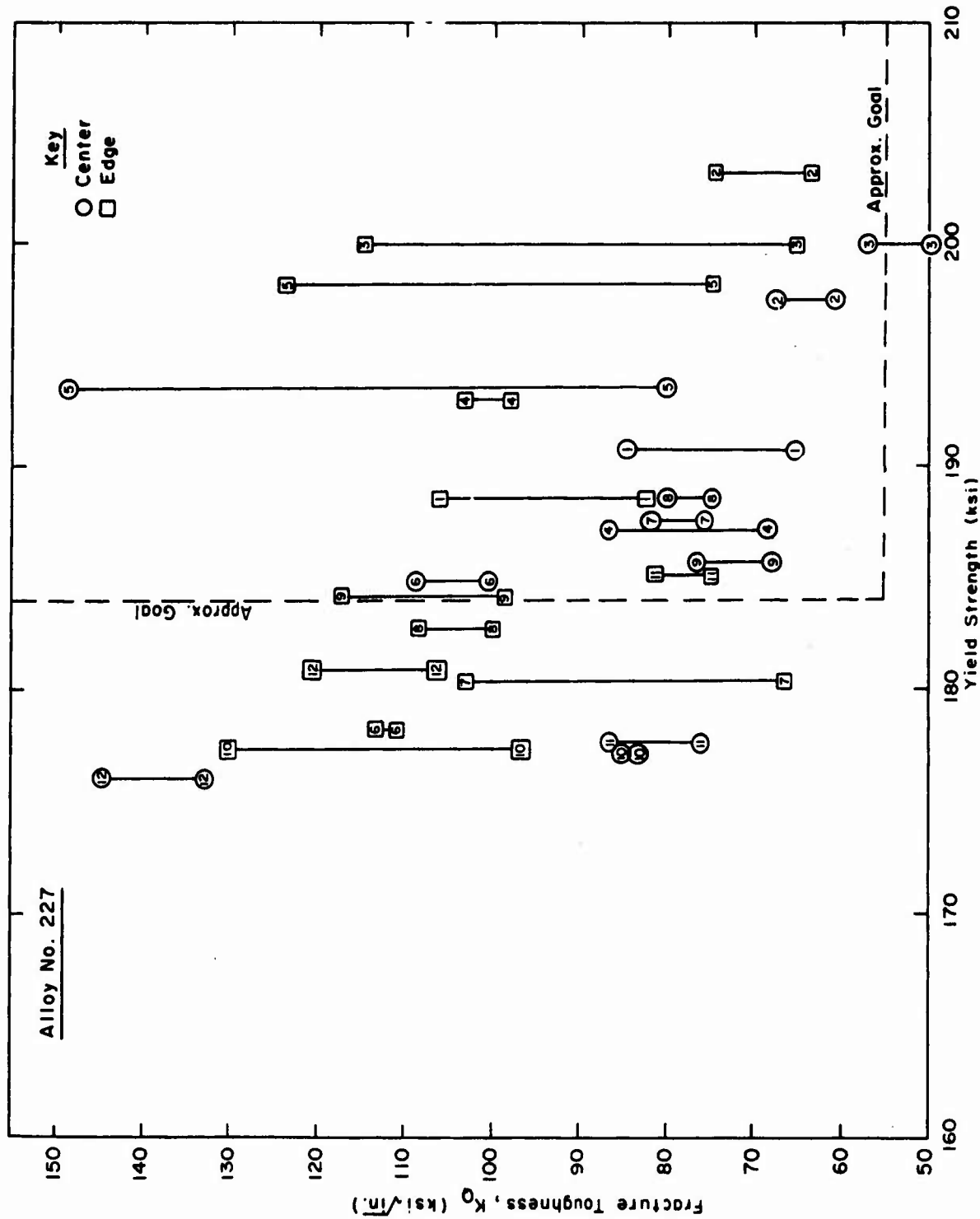

Figure 79. Alloy 227 (7Mo-4Cr-25Al). Comparison of yield strength - toughness after the various TMT sequences defined in Tables XXXIX and XLIV. Treatments corresponding to the various codes are defined in the referenced Tables.

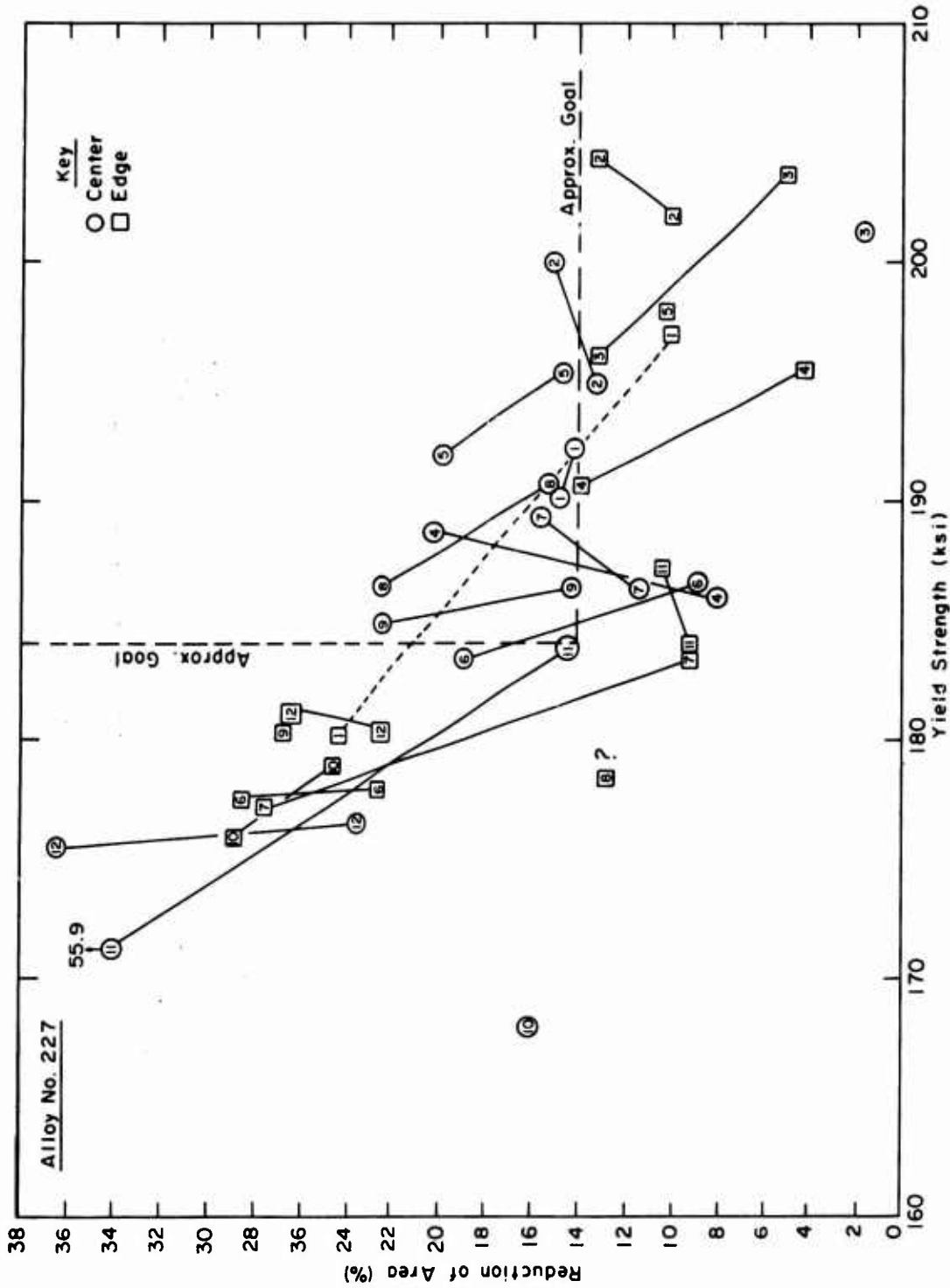

Figure 80. Alloy 227 (7Mo-4Cr-2.5Al). Comparison of yield strength - reduction of area after the various TMT sequences defined in Tables XXXIX and XLIV. Treatments corresponding to the various codes are defined in the referenced Tables.

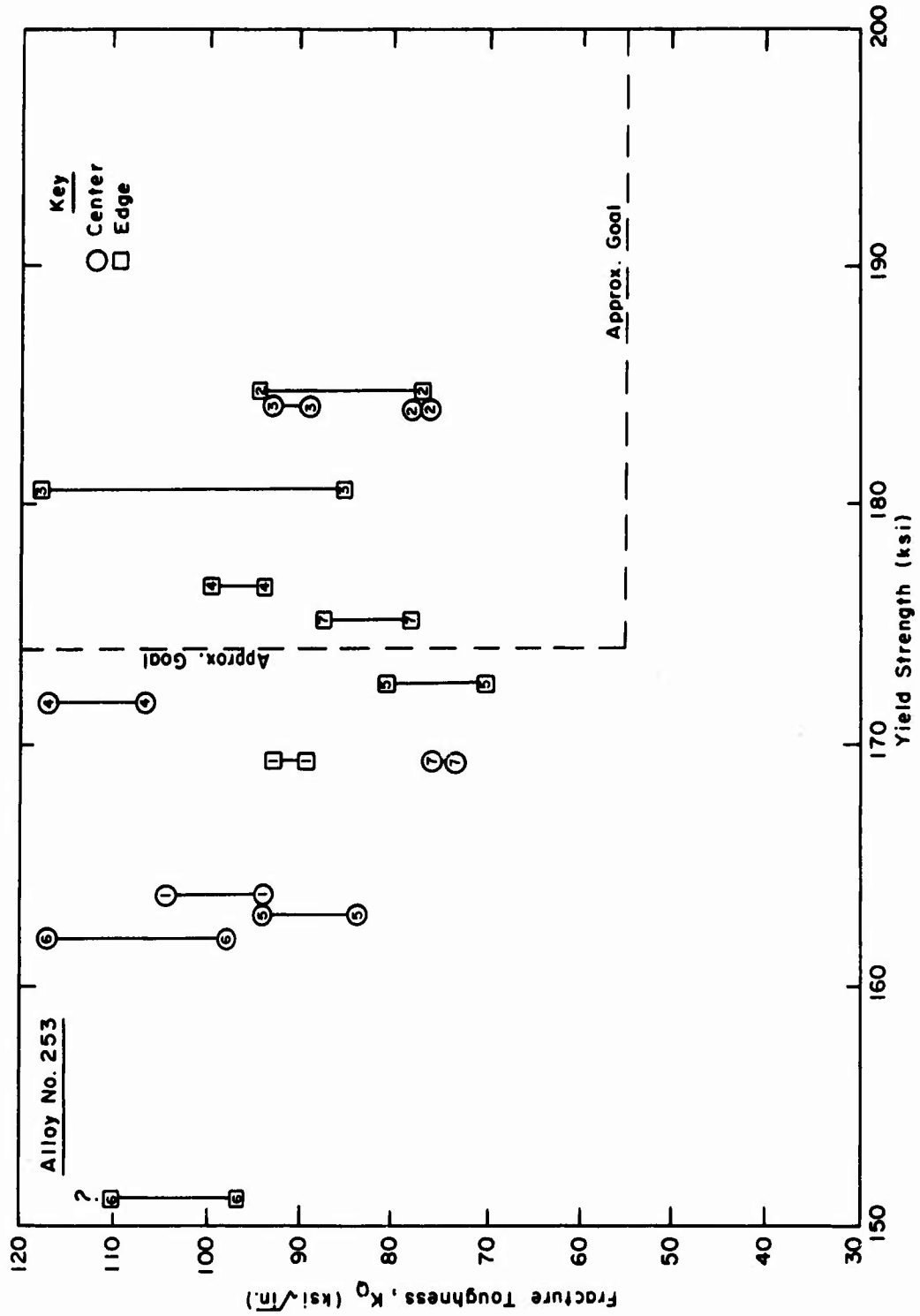

Figure 81. Alloy 253 (10Mo-8V-2.5Al). Comparison of yield strength - toughness after the various TMT sequences defined in tables XI and XIII. Treatments corresponding to the various codes are defined in the referenced Tables.

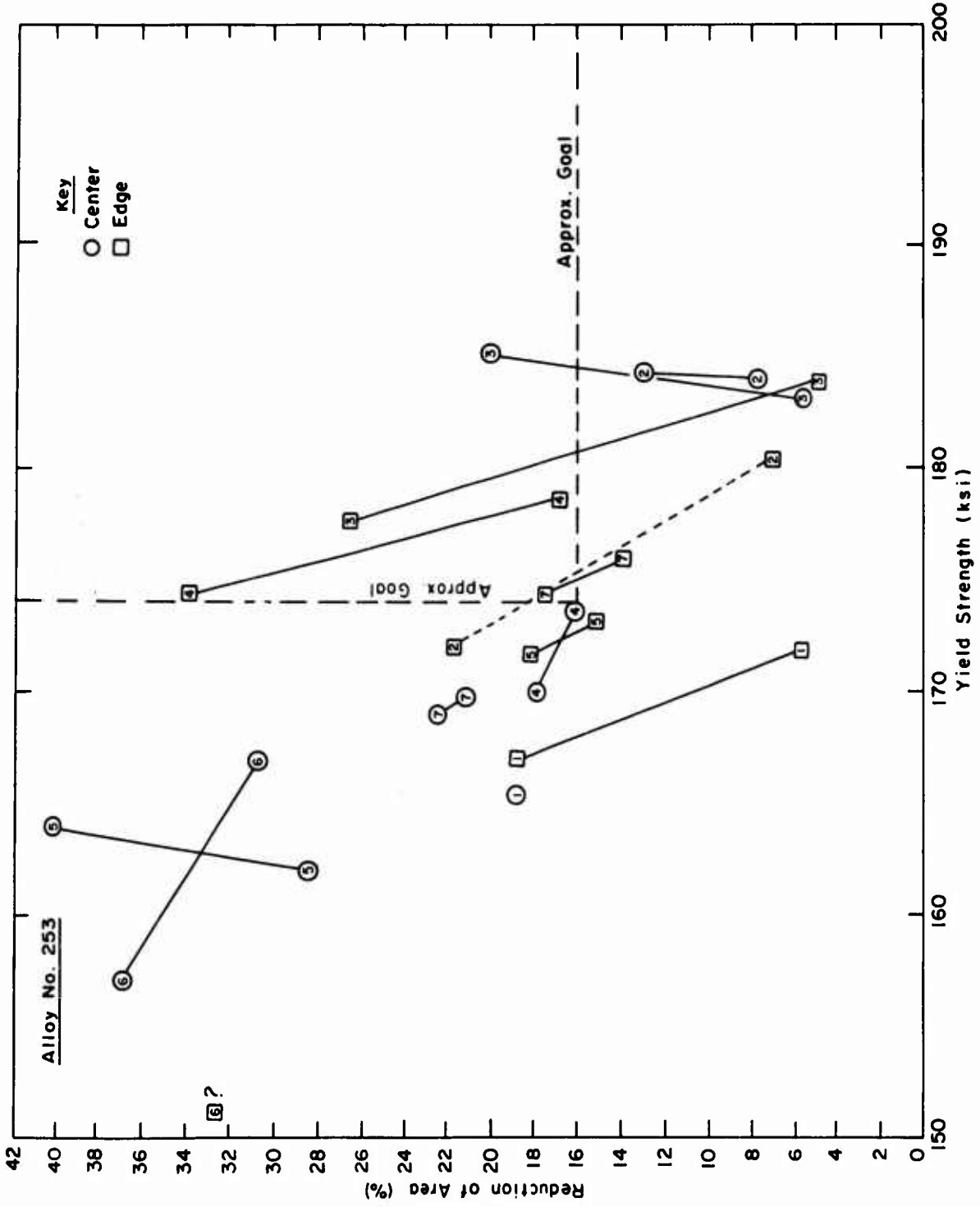

Figure 82. Alloy 253 (10Mo-8V-2.5Al). Comparison of yield strength - reduction of area after the various TM sequences defined in Tables XI and XLIII. Treatments corresponding to the various codes are defined in the referenced Tables.

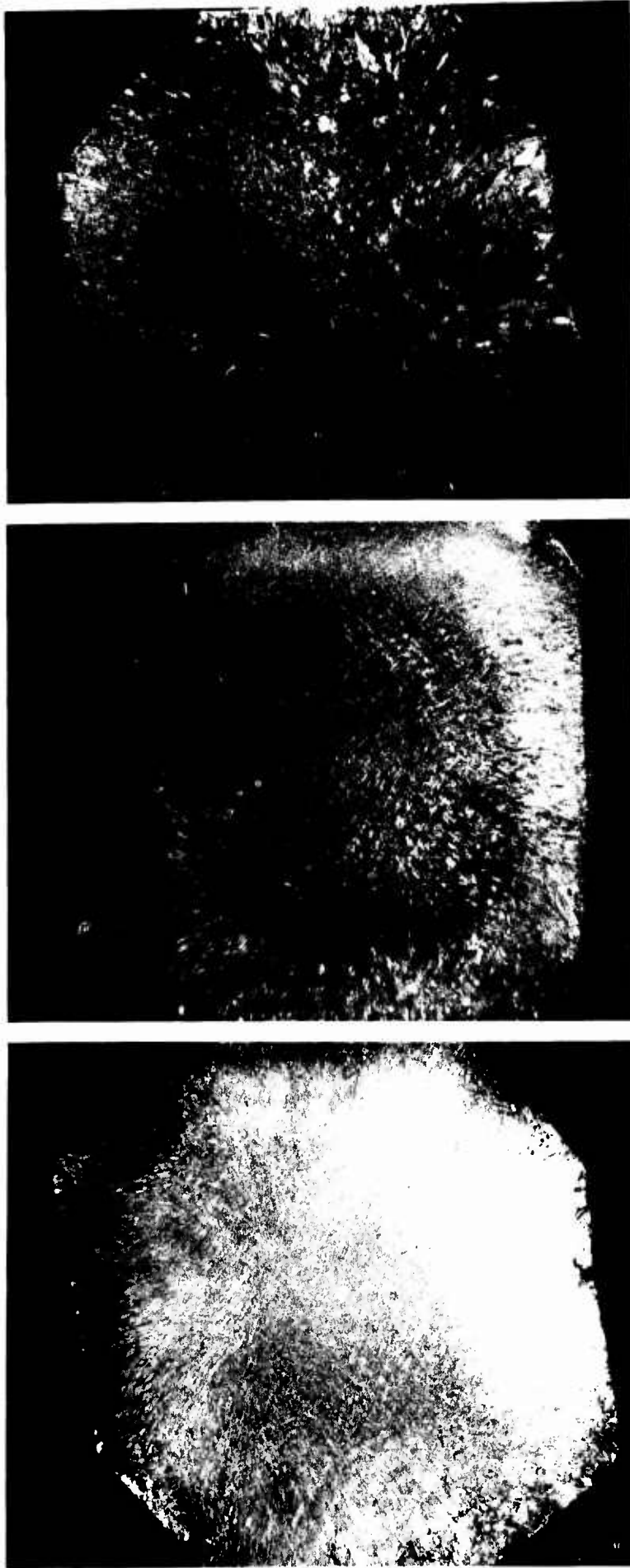

Figure 83. Photomicrographs at 6-3/4 inch RCS billet stage. (Left) Alloy 334 (10Mo-6Cr-2.5Al); (Center) Alloy 227 (7Mo-4Cr-2.5Al) and, (Right) Alloy 253 (10Mo-8V-2.5 Al). Detailed study of microstructure revealed no evidence of "beta flecks." Approximate magnification X1/2.

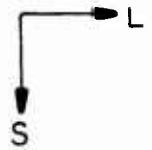
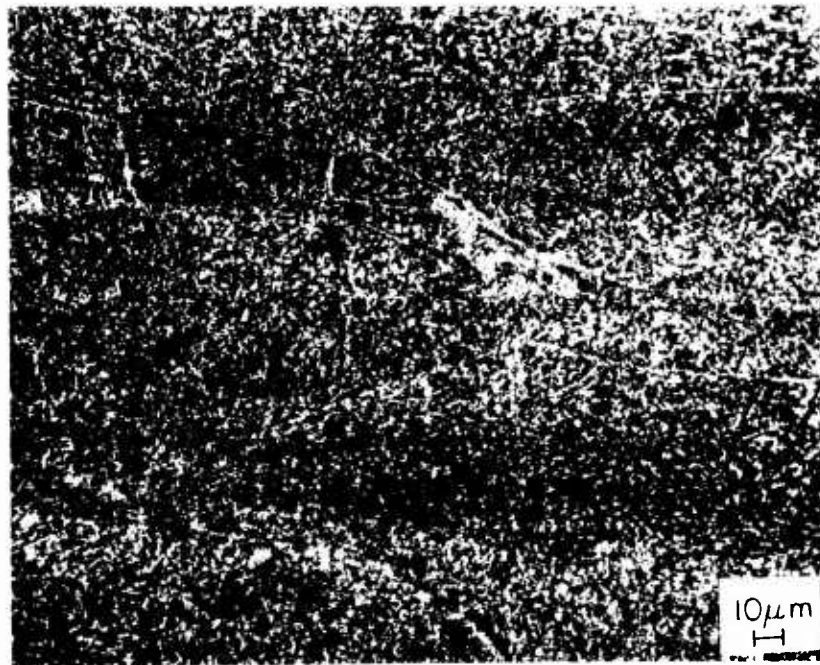
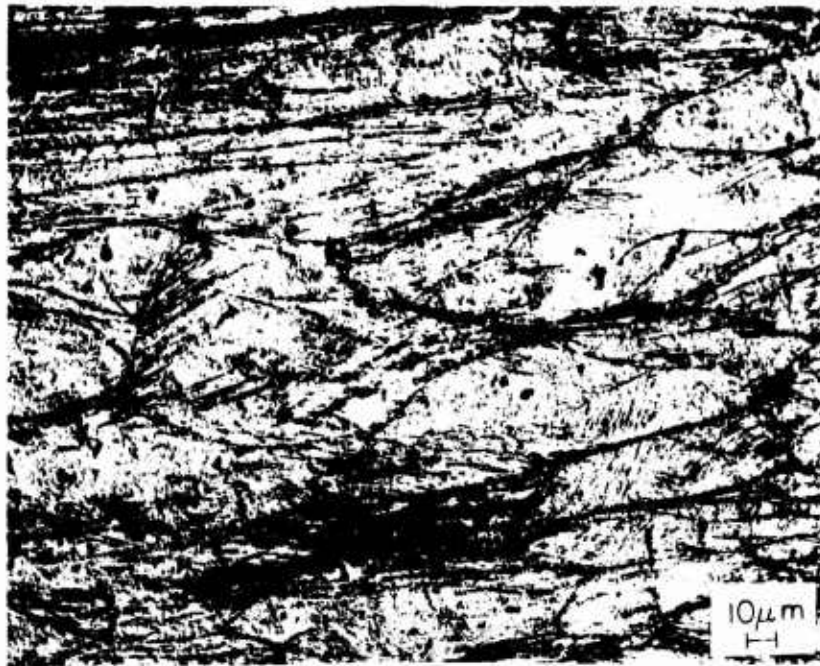

Figure 84. Microstructure of (top) Alloy 334 (10Mo-6Cr-2.5Al) and (bottom) Alloy 227 (7Mo-4Cr-2.5Al) as forged from 10.5 inch RCS to 6-3/4 inch RCS and allowed to air cool, both X275.

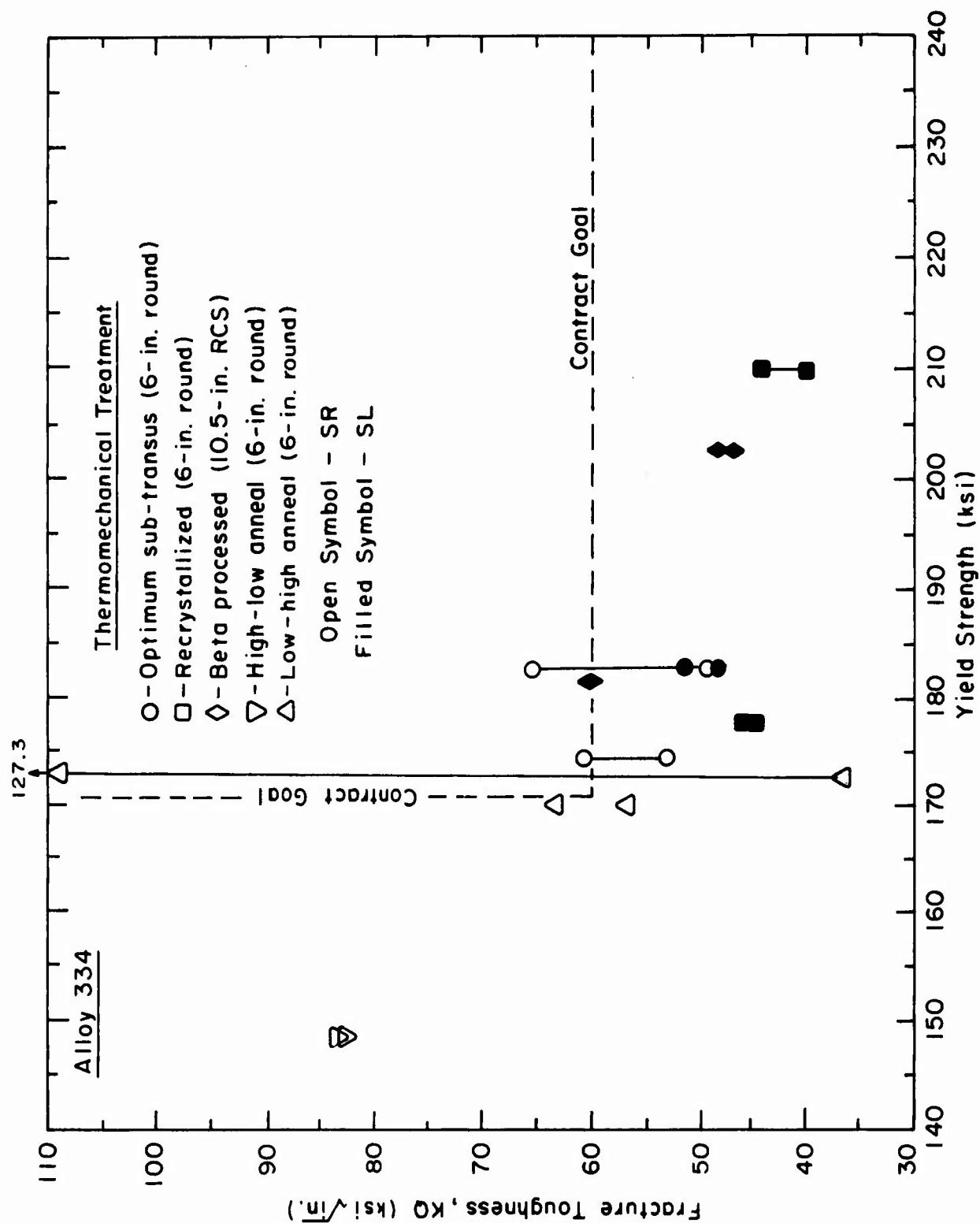

Figure 85. Transverse yield strength - toughness (K_Q) alloy 334 (10Mo-6Cr-2.5Al) after various thermomechanical treatments.

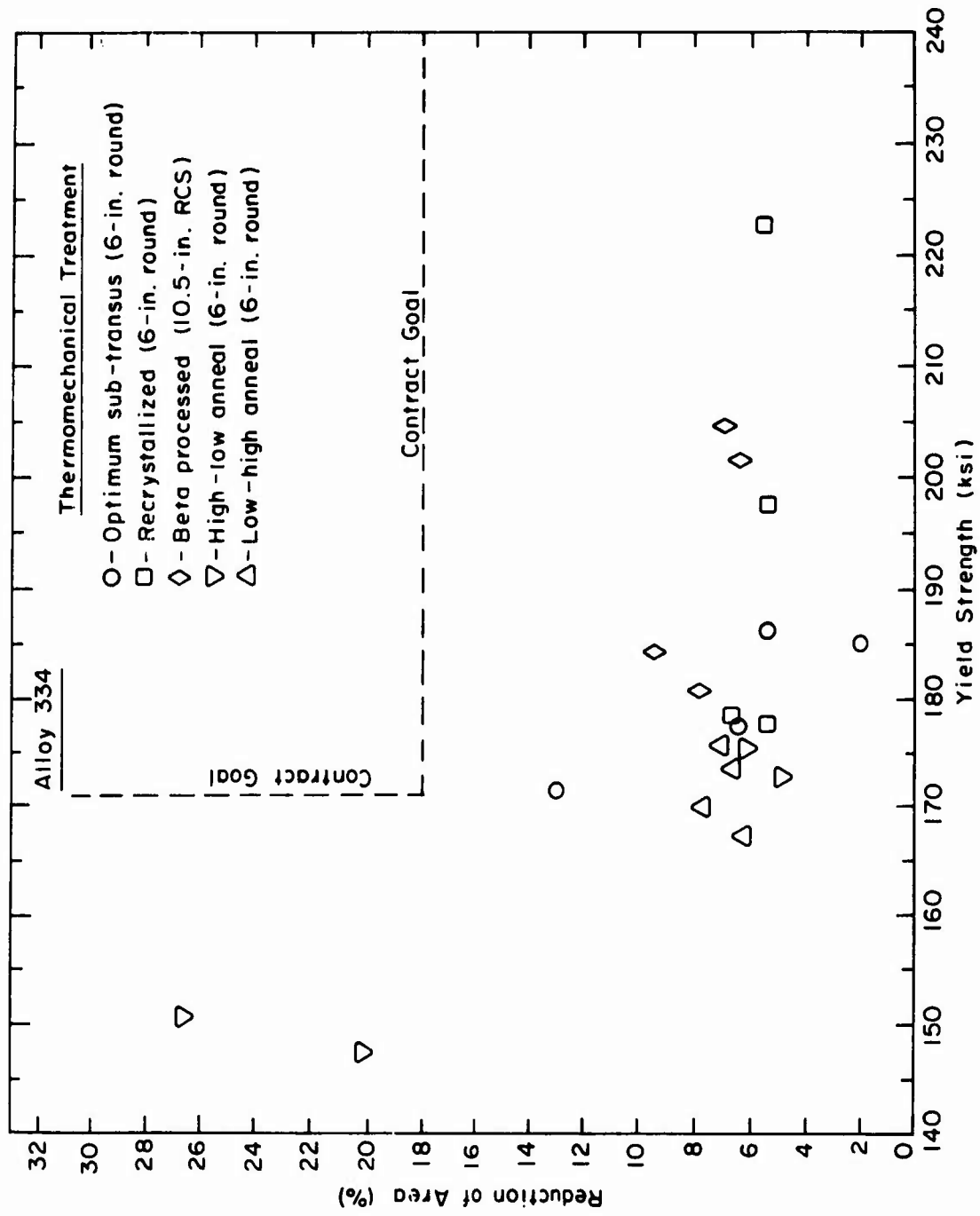

Figure 86. Transverse yield strength - ductility (RA) alloy 334 (10Mo-6Cr-2.5Al) after various thermomechanical treatments.

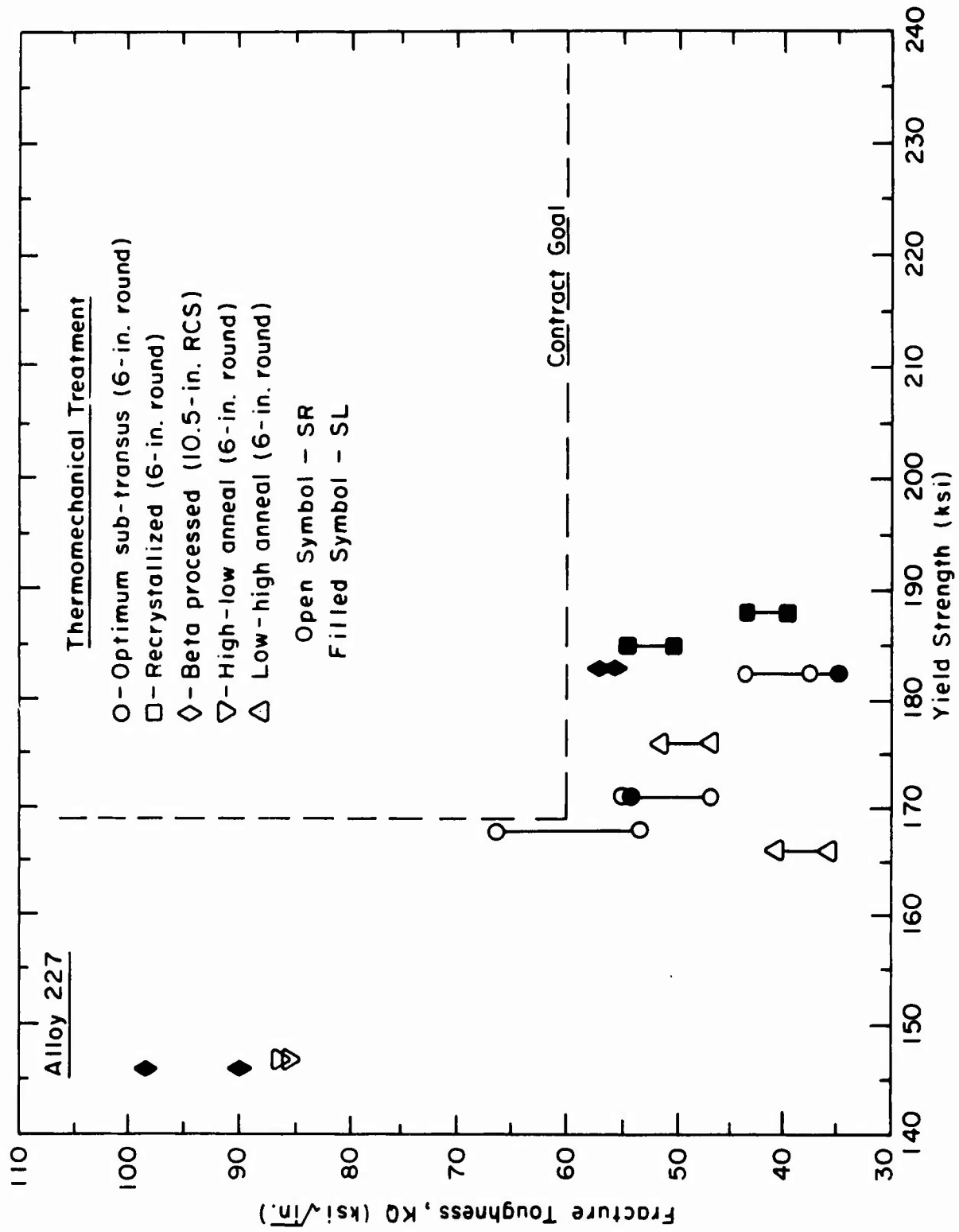

Figure 87. Transverse yield strength - toughness (K_Q) alloy 227 (7Mo-4Cr-2.5Al) after various thermomechanical treatments.

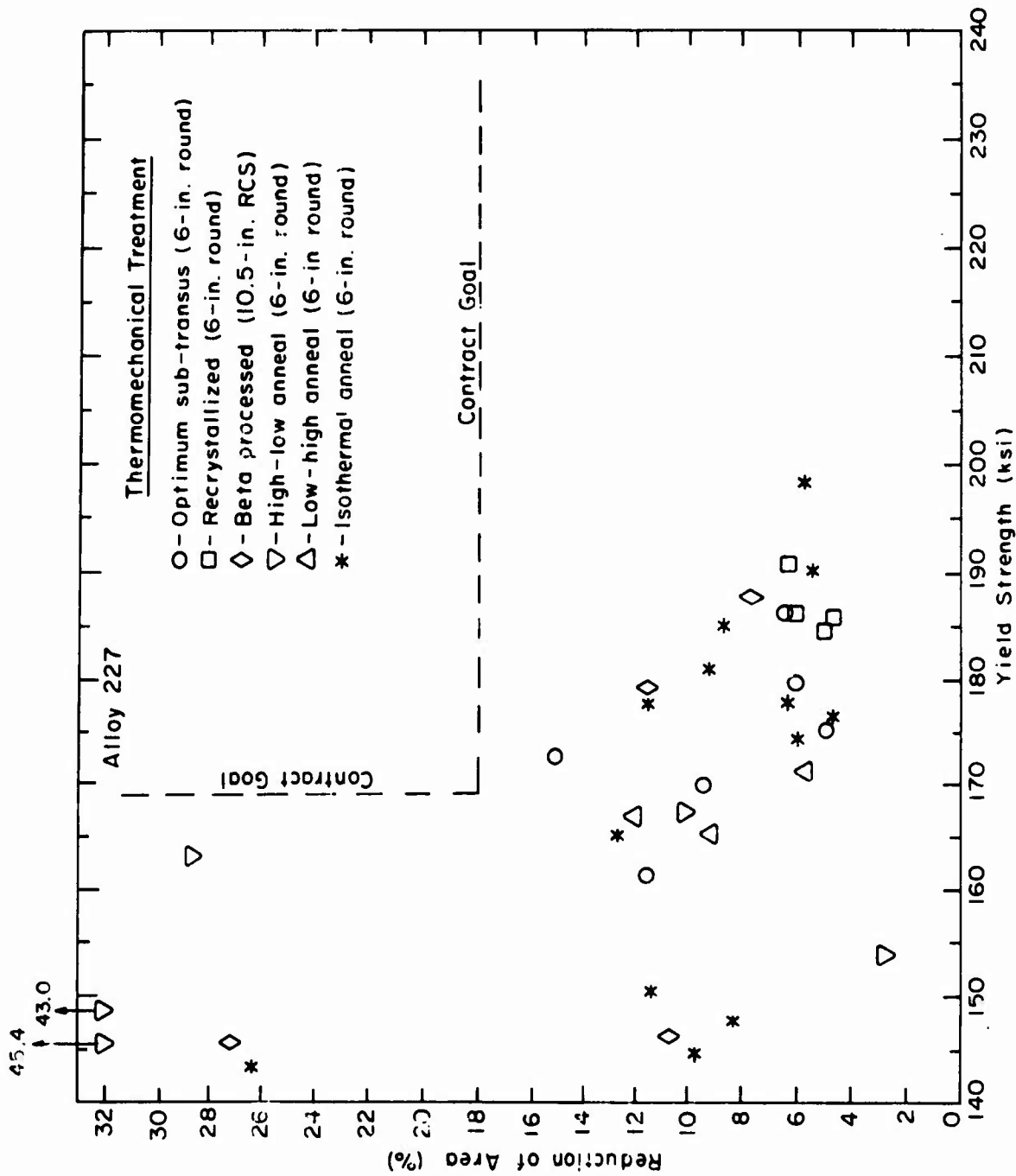

Figure 88. Transverse yield strength - ductility (RA) alloy 227 (7Mo-4Cr-2.5Al) after various thermomechanical treatments.

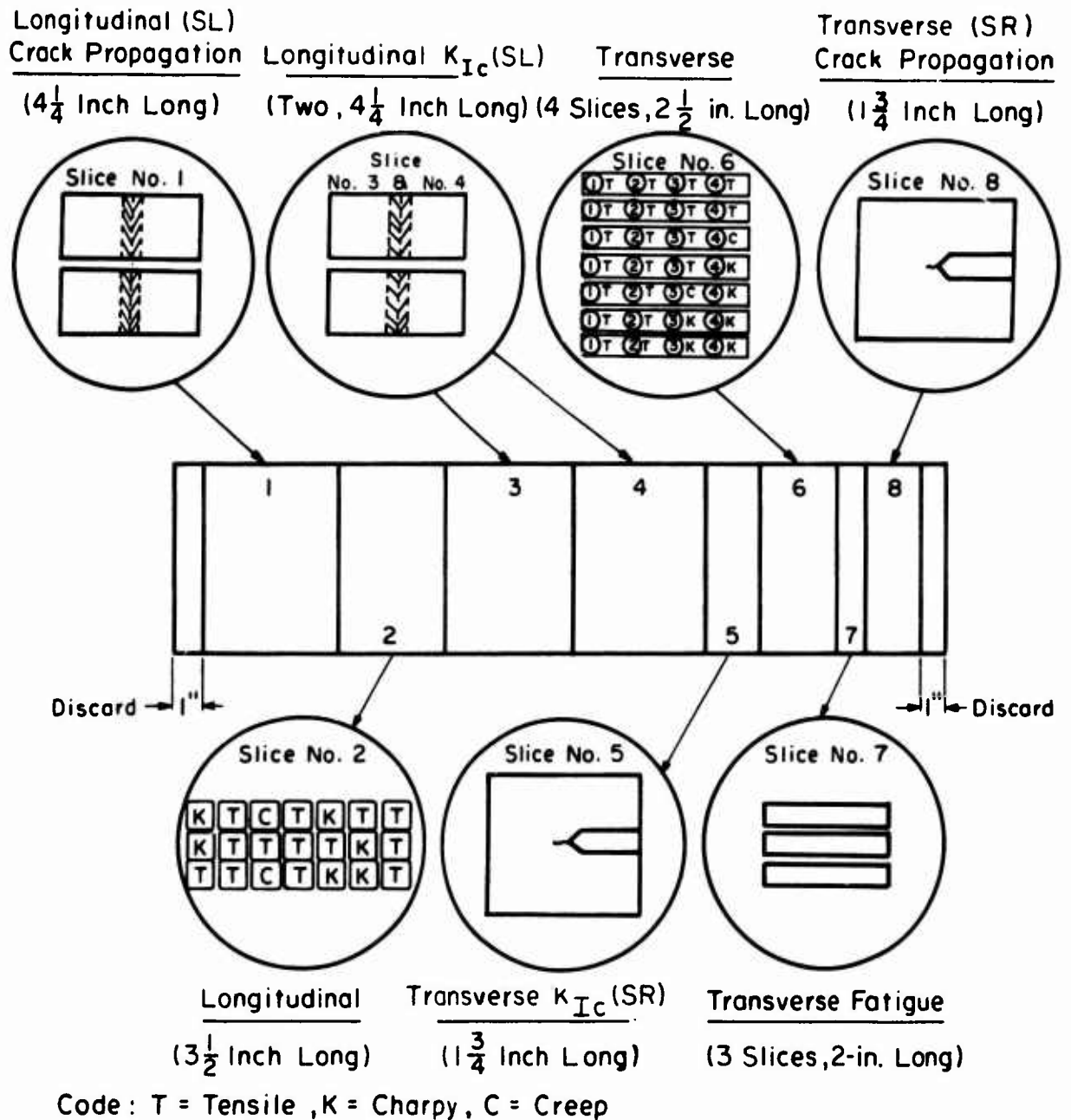
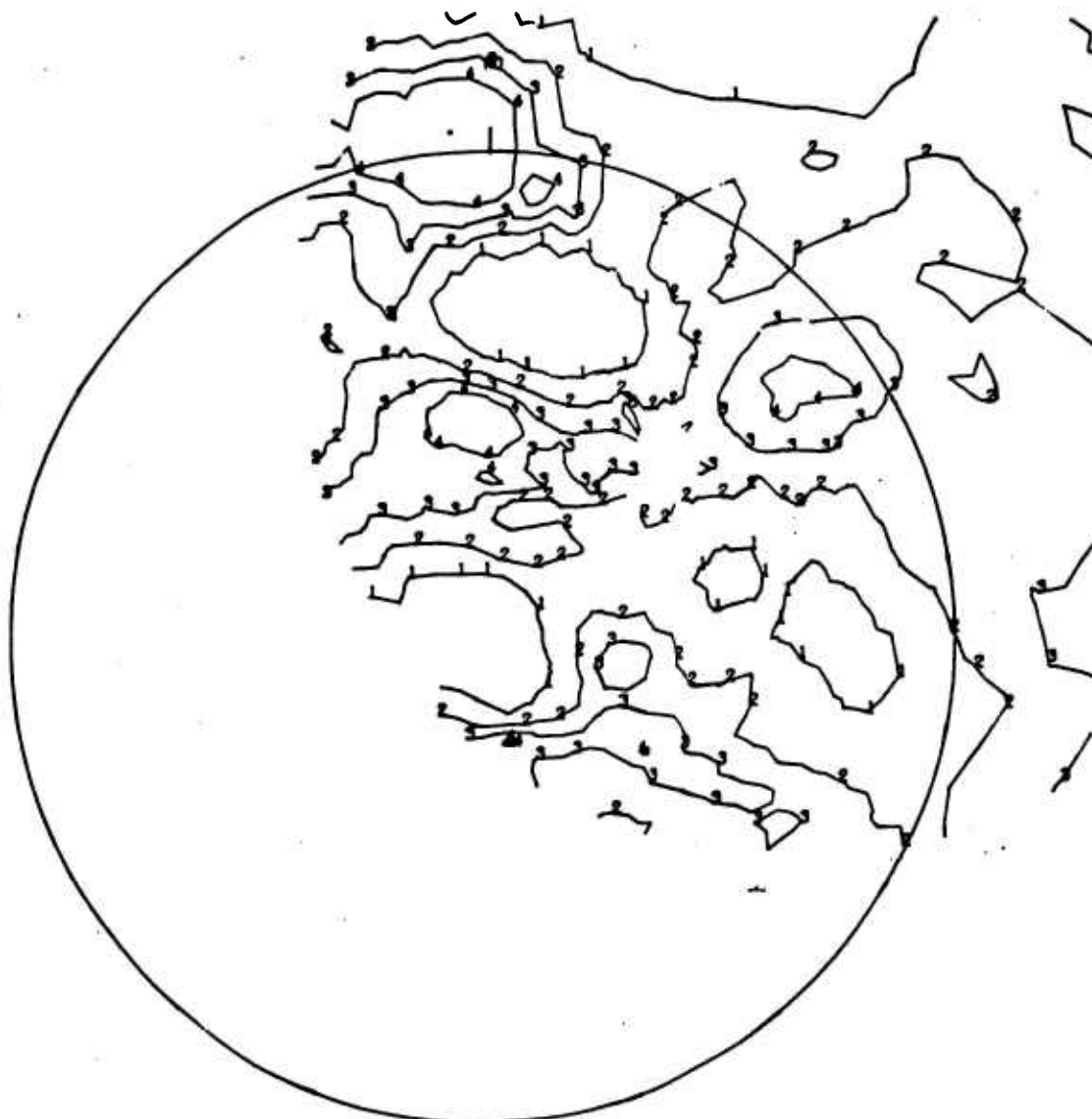
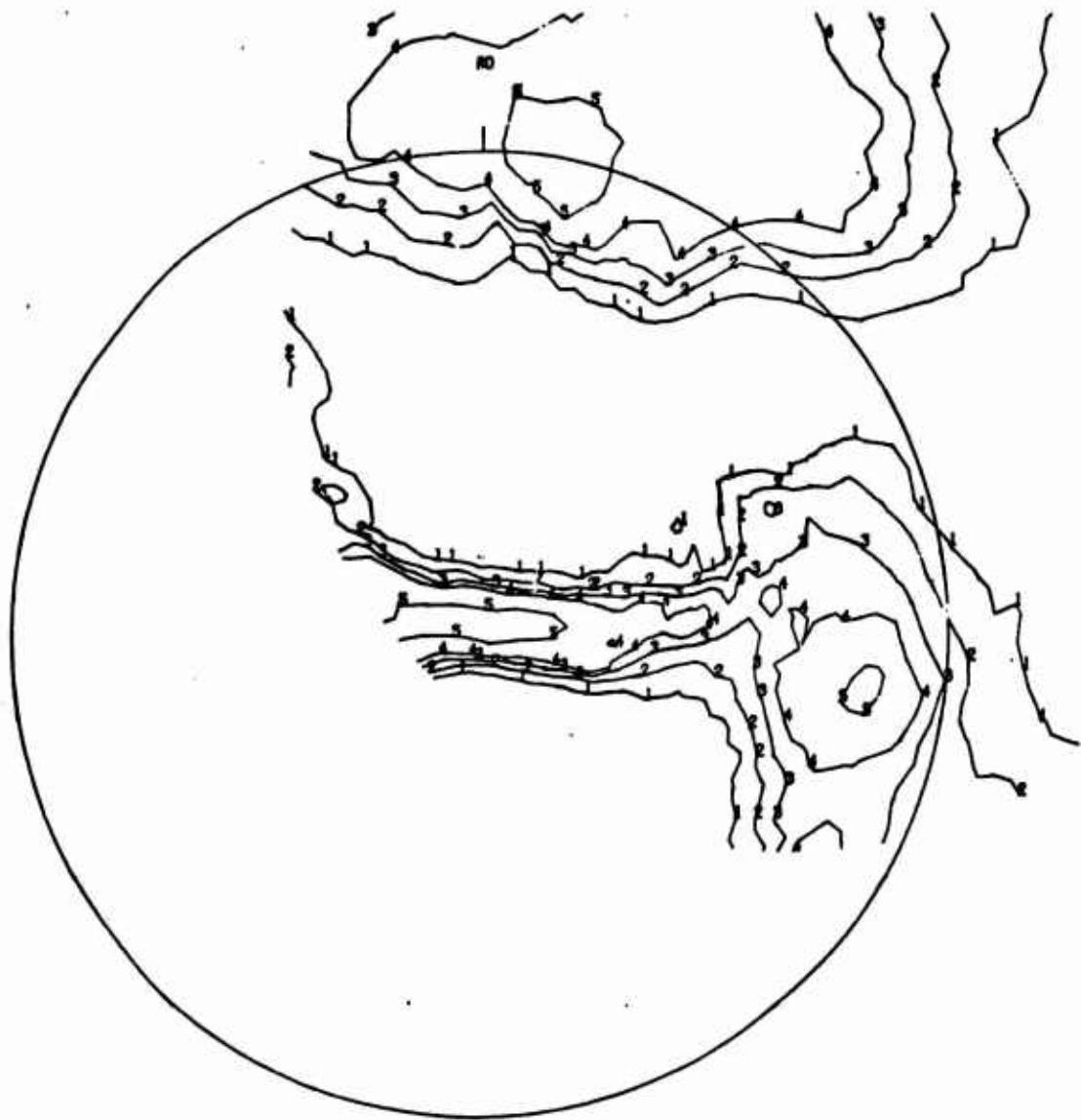

Figure 89. Specimen location diagram, indicating position of the various types of samples in the full six inch diameter billet.



1	.8000	2	1.0000	3	1.5000	4	2.0000	5	4.0000
6	8.0000	7	14.0000	8	20.0000	9	25.0000	0	30.0000

Figure 90a. Pole figure of alloy 334 (10Mo-6Cr-2.5Al) plate, (110) beta planes. RW plane with R orientated top to bottom of page (see Appendices D and F).



1	.5000	2	1.0000	3	1.5000	4	2.0000	5	4.0000
6	8.0000	7	14.0000	8	20.0000	9	25.0000	0	30.0000

Figure 90b. Pole figure of alloy 334 (10Mo-6Cr-2.5Al) plate, (200) beta planes. RW plane with R orientated top to bottom of page (see Appendices D and F).



1	.5000	2	1.0000	3	1.5000	4	2.0000	5	4.0000
6	8.0000	7	14.0000	8	20.0000	9	25.0000	0	30.0000

Figure 91a. Pole figure of alloy 334 (10Mo-6Cr-2.5Al) billet, (110) beta planes. SR plane (See Appendices D and F)

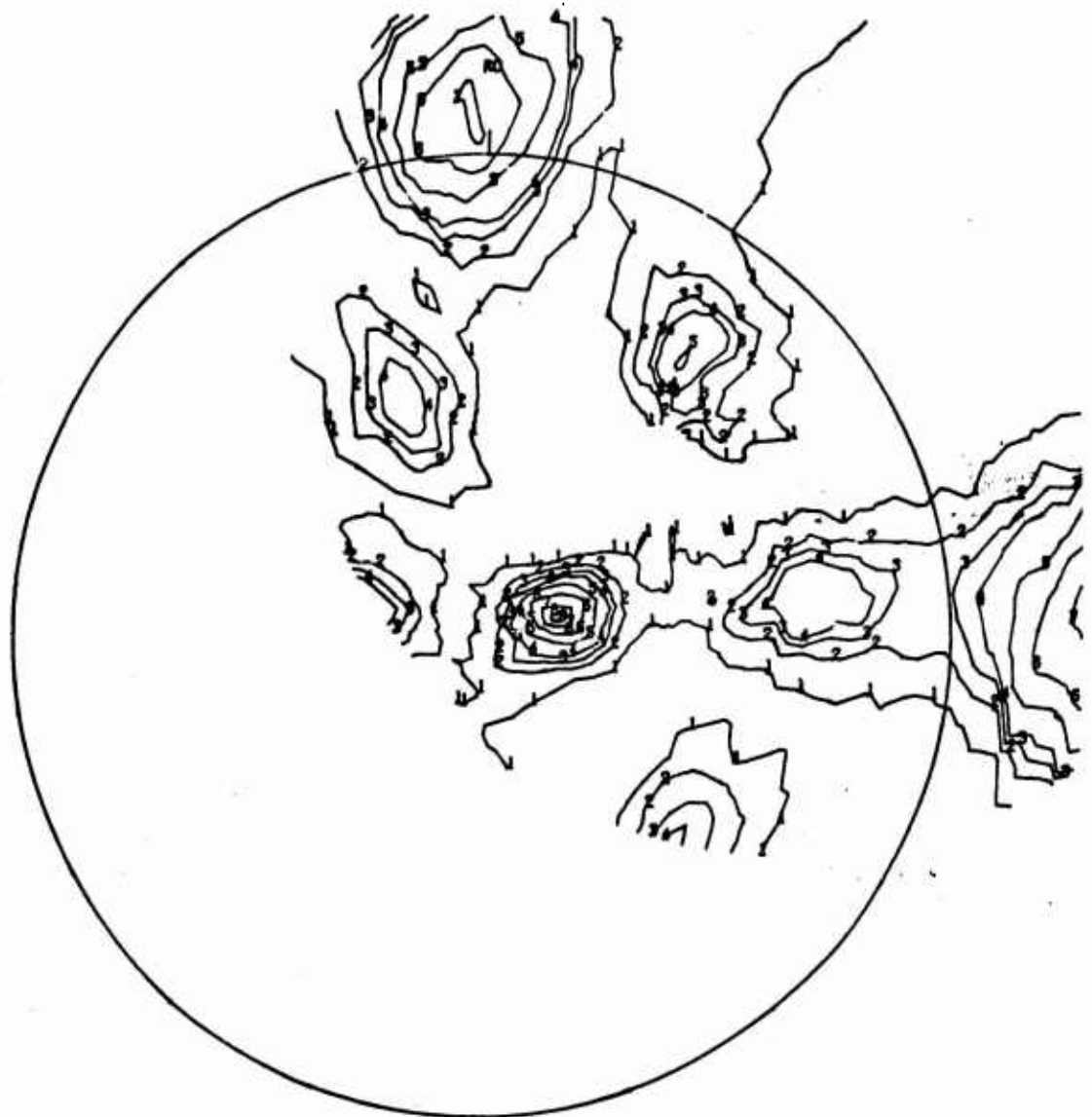

1	.5000	2	1.0000	3	1.5000	4	2.0000	5	4.0000
6	8.0000	7	14.0000	8	20.0000	9	25.0000	0	30.0000

Figure 91b. Pole figure of alloy 334 (10Mo-6Cr-2.5Al) billet, (200) beta planes. SR plane (See Appendices D and F).



1	.5000	2	1.0000	3	1.5000	4	2.0000	5	4.0000
6	8.0000	7	14.0000	8	20.0000	9	25.0000	0	30.0000

Figure 92a. Pole figure of alloy 227 (7Mo-4Cr-2.5Al) billet, (110) beta planes. SR plane (see Appendices D and F).

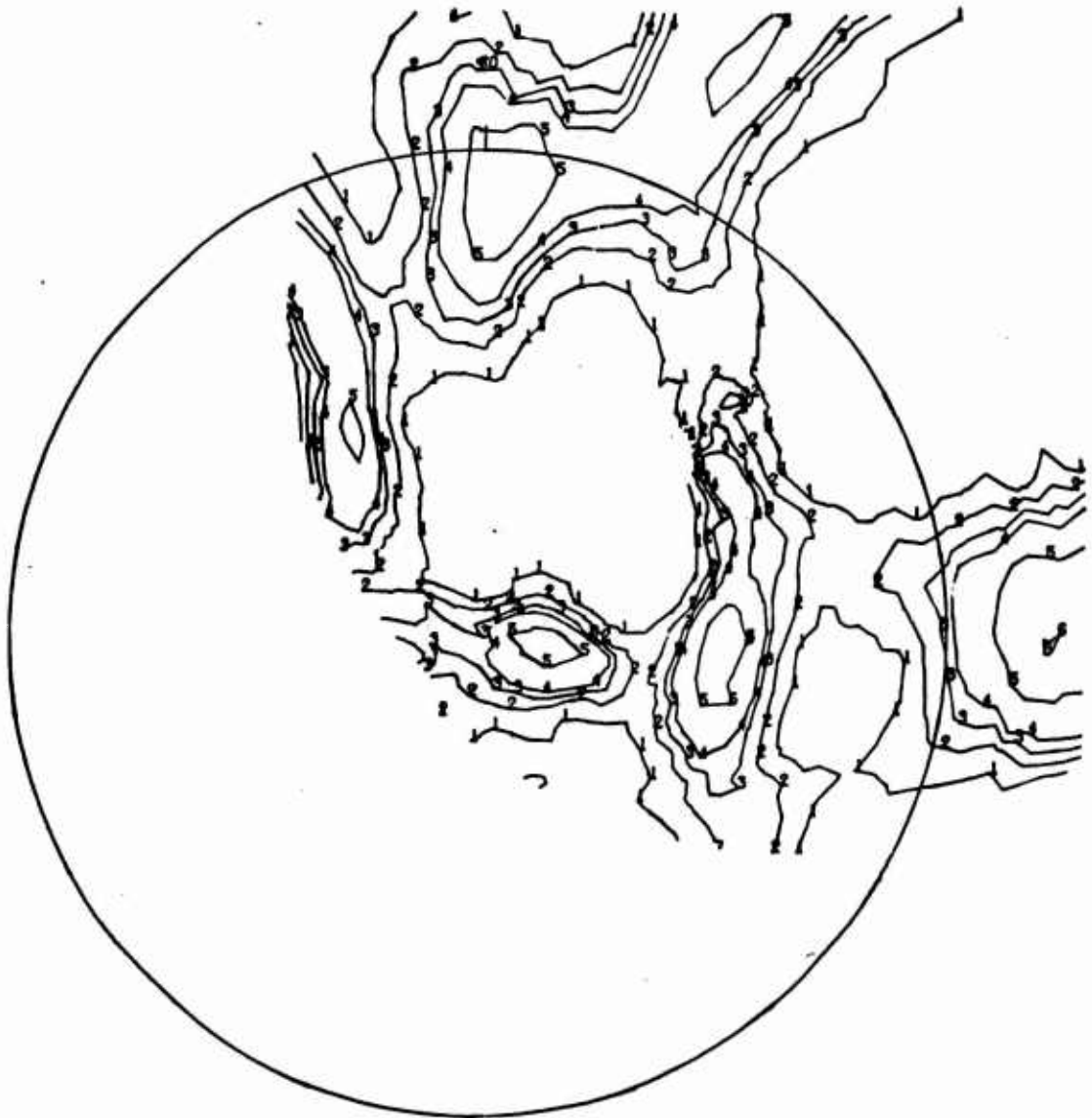

1	.8000	2	1.0000	3	1.5000	4	2.0000	5	4.0000
6	8.0000	7	14.0000	8	20.0000	9	25.0000	0	30.0000

Figure 92b. Pole figure of alloy 227 (7Mo-4Cr-2.5Al) billet, (200) beta planes. SR plane (see Appendices D and F).

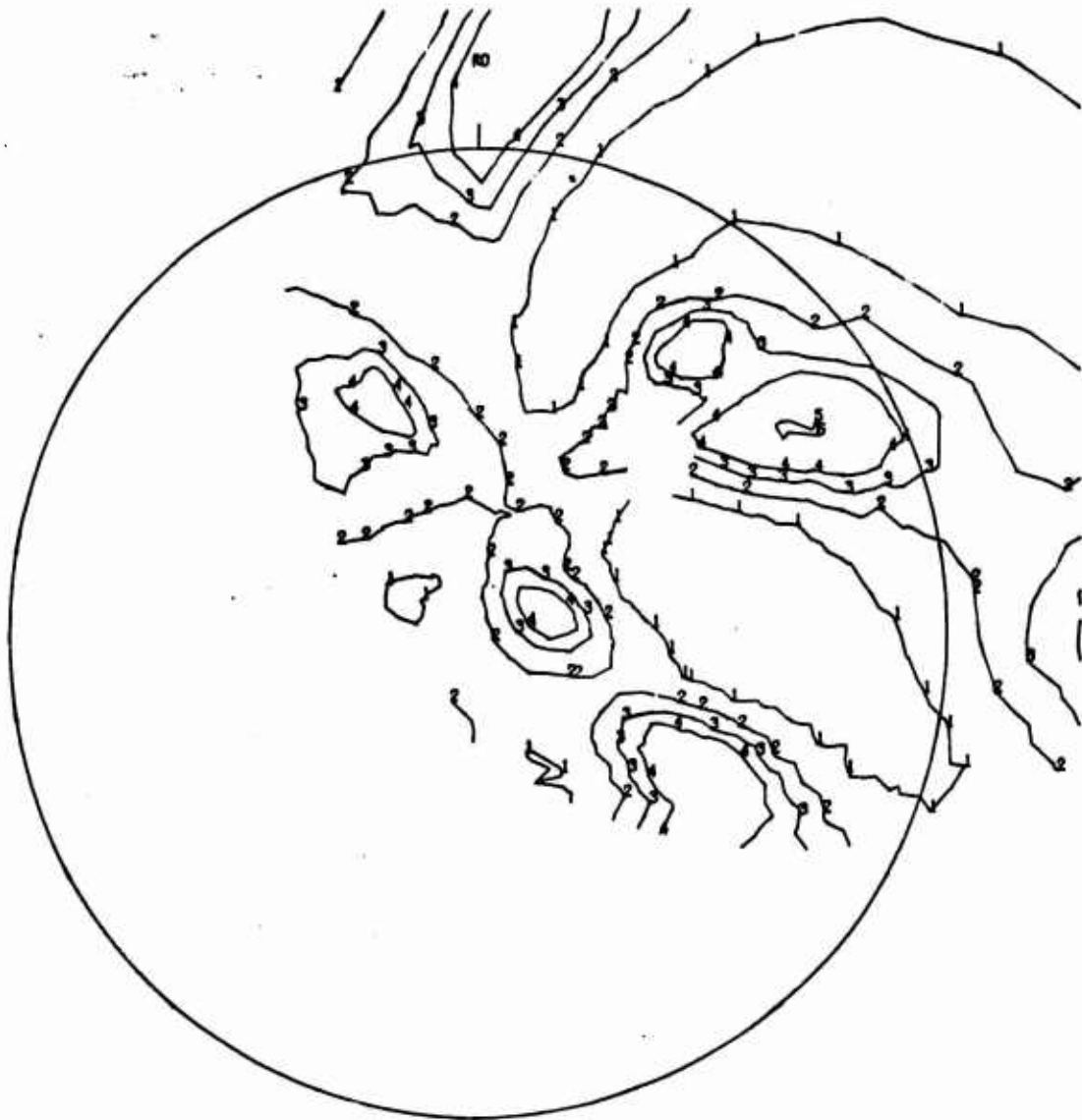

1	.5000	2	1.0000	3	1.5000	4	2.0000	5	4.0000
6	8.0000	7	14.0000	8	20.0000	9	25.0000	0	30.0000

Figure 93a. Pole figure of alloy 334 (10Mo-6Cr-2.5Al) billet, (110) beta planes, LS plane with L orientated top to bottom of page (see Appendices D and F).

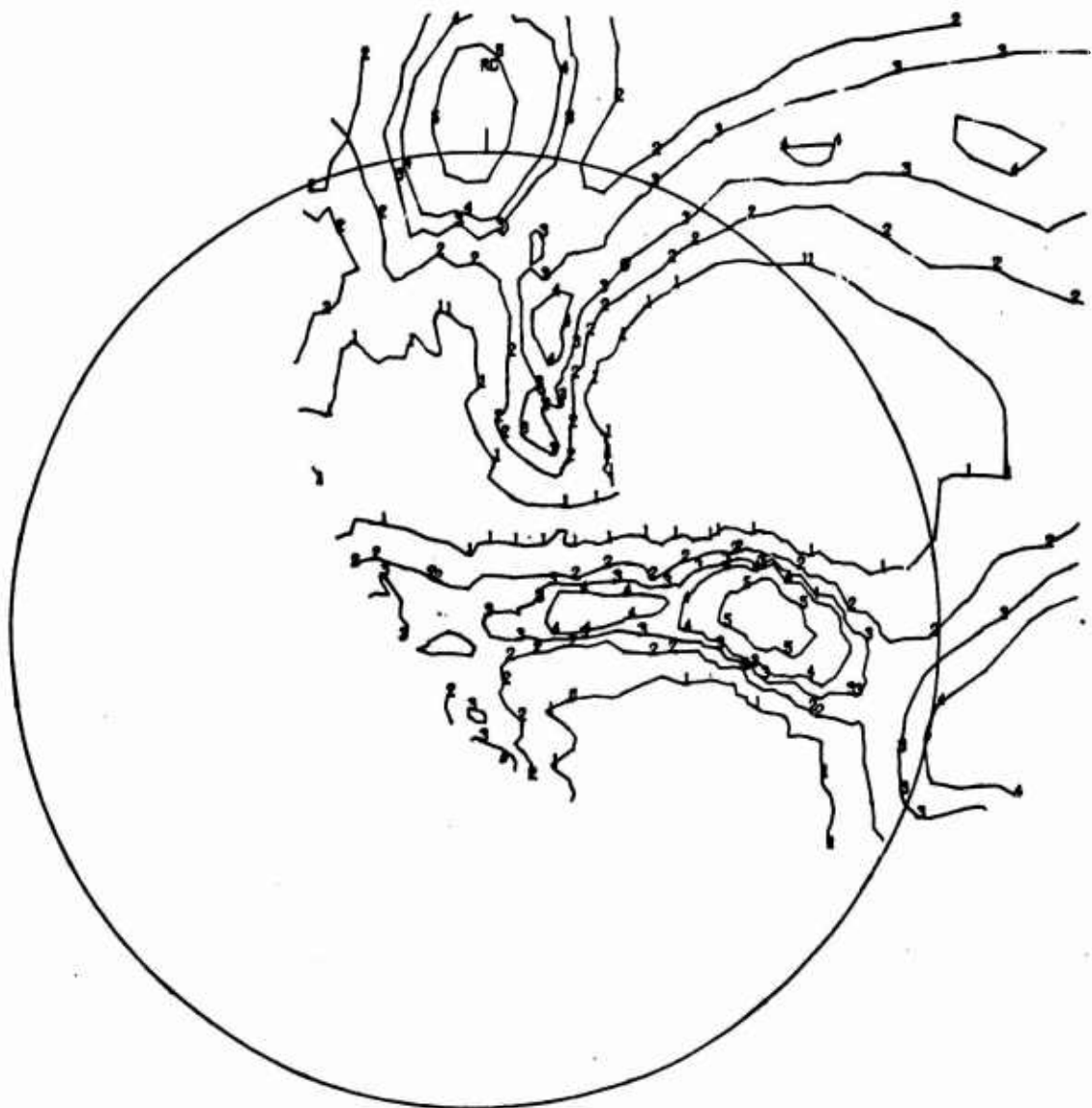

1	.5000	2	1.0000	3	1.5000	4	2.0000	5	4.0000
6	8.0000	7	14.0000	8	20.0000	9	25.0000	0	30.0000

Figure 93b. Pole figure of alloy 334 (10Mo-6Cr-2.5Al) billet, (200) beta planes, LS plane with L orientated top to bottom of page (see Appendices D and F).



1	.5000	2	1.0000	3	1.5000	4	2.0000	5	4.0000
6	8.0000	7	14.0000	8	20.0000	9	25.0000	0	30.0000

Figure 93c. Pole figure of alloy 334 (10Mo-6Cr-2.5Al) billet, (211) beta planes, LS plane with L orientated top to bottom of page (see Appendices D and F).

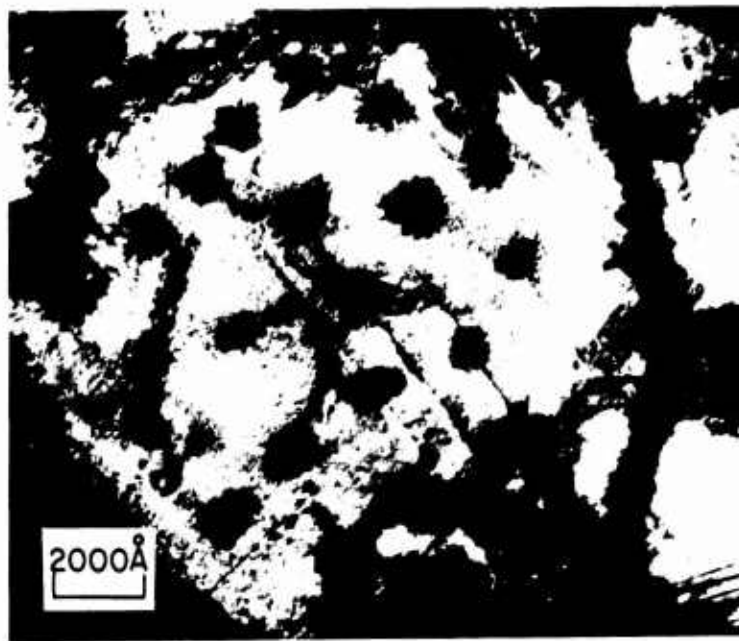

Figure 94 . Alloy 334(10Mo-6Cr-2.5Al). Solution treated 1300F-4 hr WQ, pre-aged 662F-70 hr. Note uniform distribution of α -clusters presumably resulting from precipitation on solute lean β' zones.

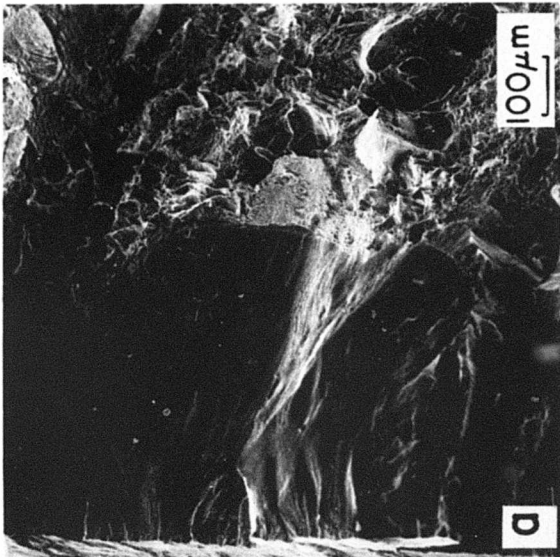
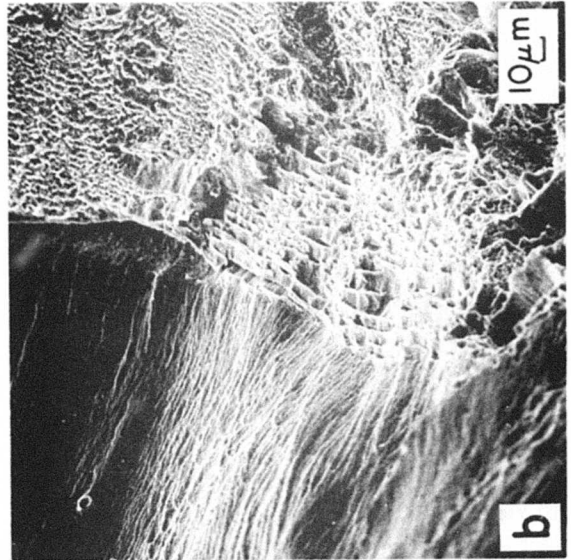
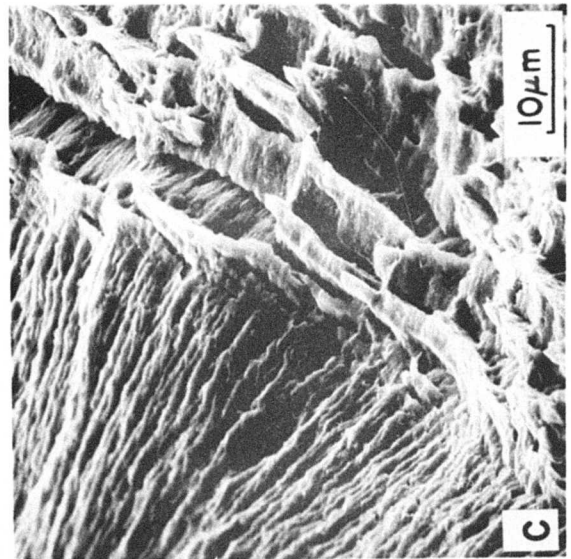
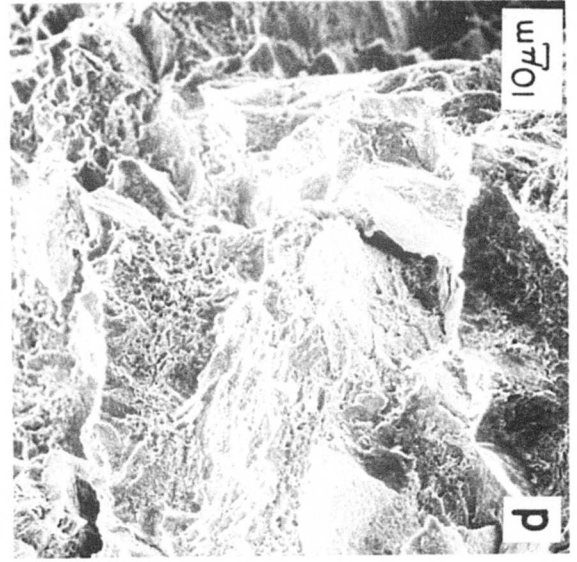

Figure 99 . Alloy 334(10Mo-6Cr-2.5Al), sample 4CLY1. Solution treated 1350F-4 hr WQ, single aged 900F-96 hr. SEM of fracture surface: (a) X80, (b) X300, (c) X1500 - precrack/fast fracture transition, (d) X300 - fast fracture. YS(ksi): 186, RA(%): 23, K_Q(ksi/in): 86.



DCP → S
 ↑ R



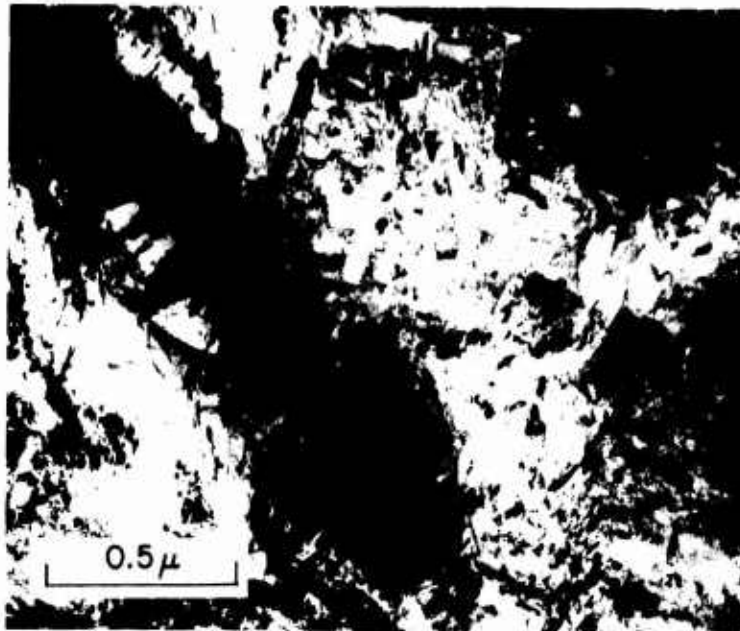

Figure 96 . Alloy 253(10Mo-8V-2.5Al), sample 3C3Y1. Solution treated 1275F-4 hr WQ, single aged 950F-96 hr. Note elongated primary alpha plates ($\sim 500 \text{ \AA}$ thick) and precipitated alpha plates of the non-Burger's type.

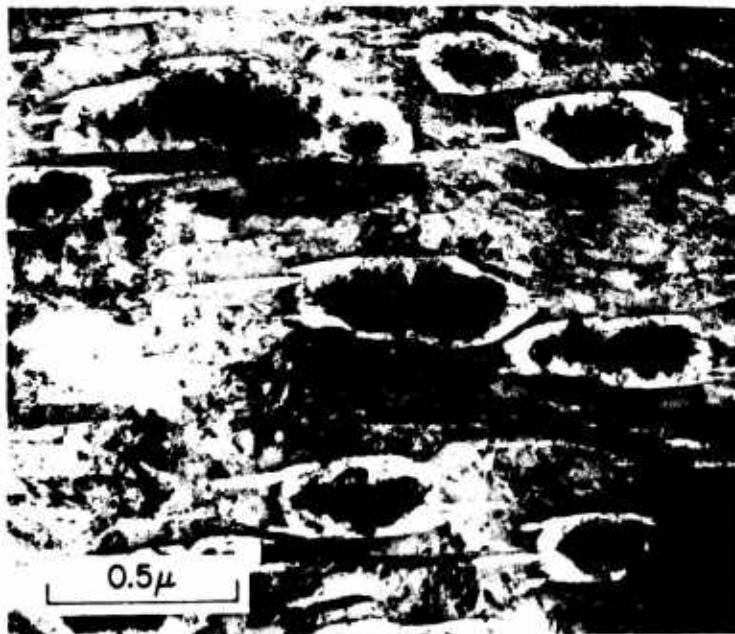

Figure 97 . Alloy 253(10Mo-8V-2.5Al), sample 3C321. Solution treated 1275F-4 hr WQ, duplex aged 750F-8 hr + 900F-8 hr. Compare with figure above. Note reduced aspect ratio of primary alpha and approximately same dispersion and size of precipitated alpha plates.

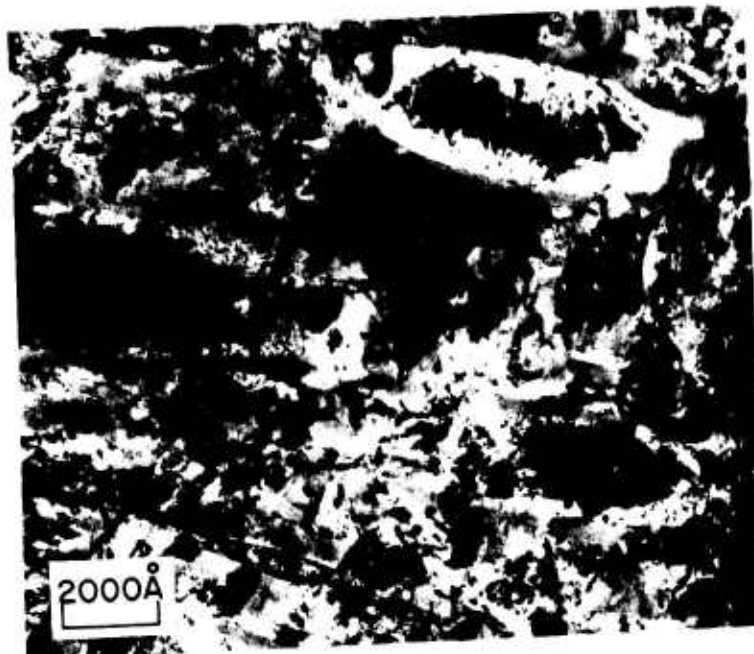
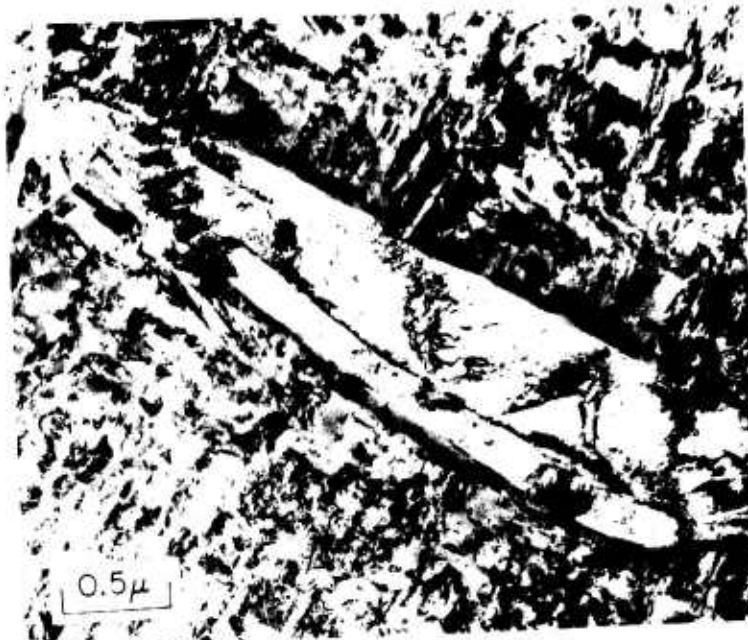

Figure 98 . Alloy 334(10Mo-6Cr-2.5Al), sample 4C1Y1.
Solution treated 1350F-4 hr WQ, single aged 900F-96 hr.
(Top) Grain boundard, primary and secondary alpha phase,
the latter of the non-Burger's type. (Bottom) Precipitated
alpha plates approximately 700 Å thick with an aspect ratio
of up to 15:1.

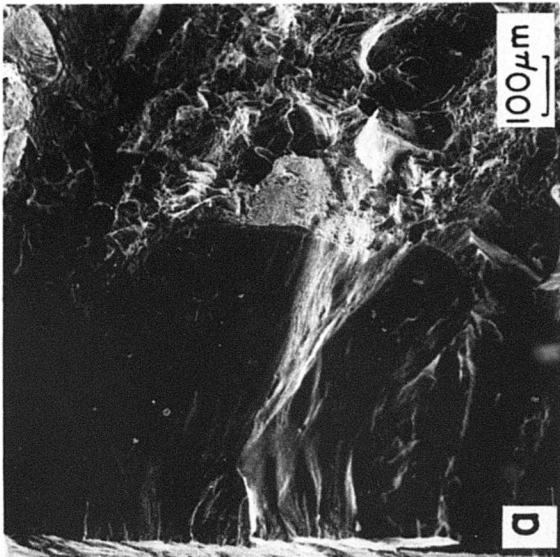
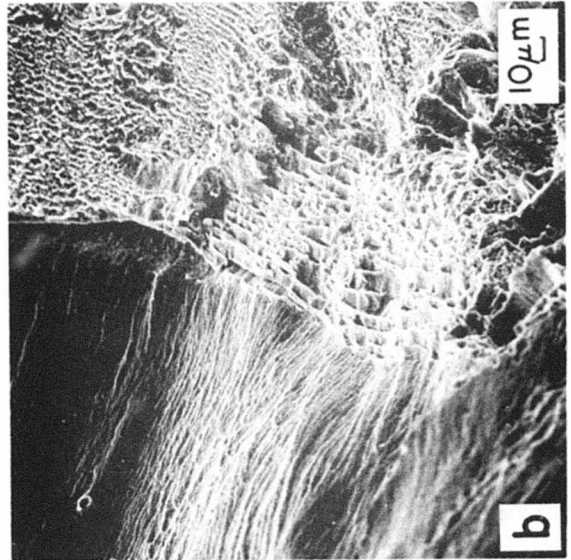
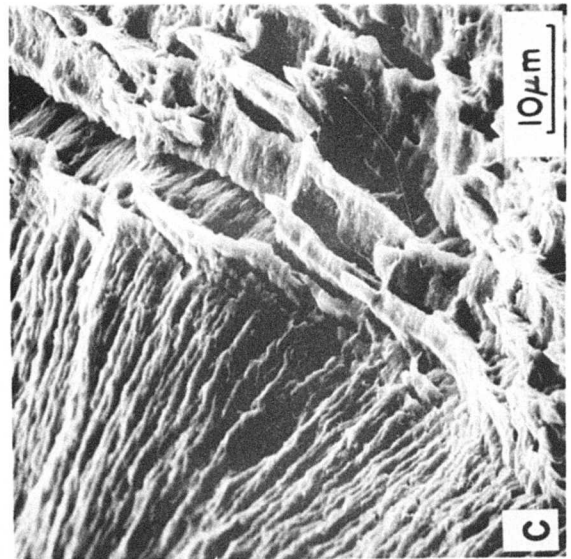
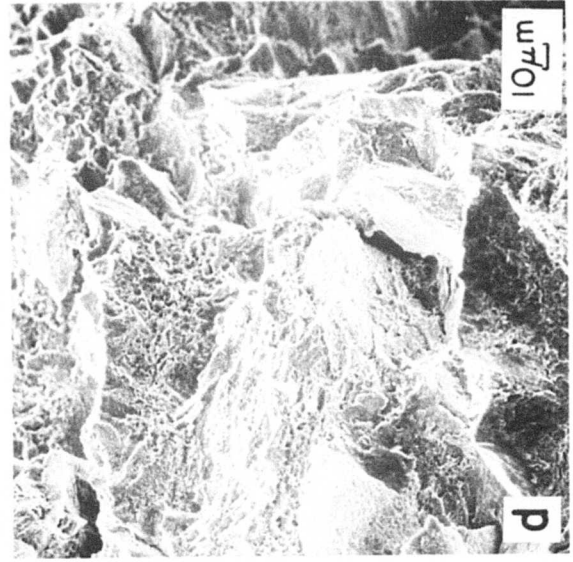

Figure 99 . Alloy 334 (10Mo-6Cr-2.5Al), sample 4CLY1. Solution treated 1350F-4 hr WQ, single aged 900F-96 hr. SEM of fracture surface: (a) X80, (b) X300, (c) X1500 - precrack/fast fracture transition, (d) X300 - fast fracture. YS(ksi): 186, RA(%): 23, K_Q(ksi/in): 86.



DCP → S
R



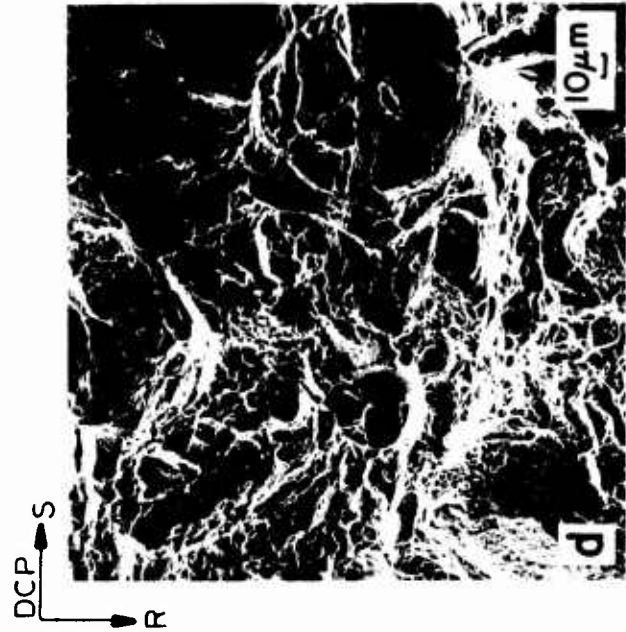

Figure 100 . Alloy 334(10Mo-6Cr-2.5Al), sample 4C1Z1. Solution treated 1350F-4 hr WQ, duplex aged 750F-8 hr + 925F-8 hr. SEM of fracture surface (a) X60, (b) X1500-precrack/fast fracture transition, (c) X300-fast fracture close to transition, (d) X300-fast fracture. Note coarser dimples than those illustrated in figure. YS(ksi): 190, RA(%): 17, K_Q (ksi/in): 69

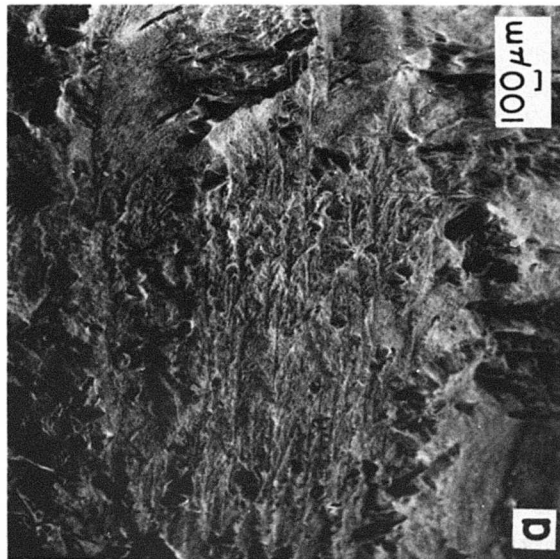
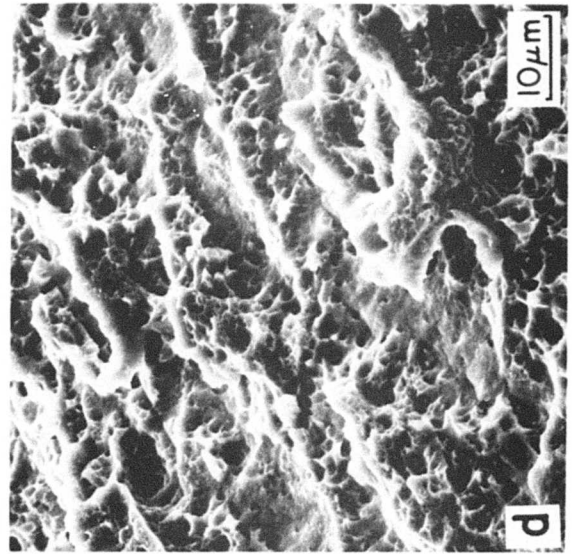
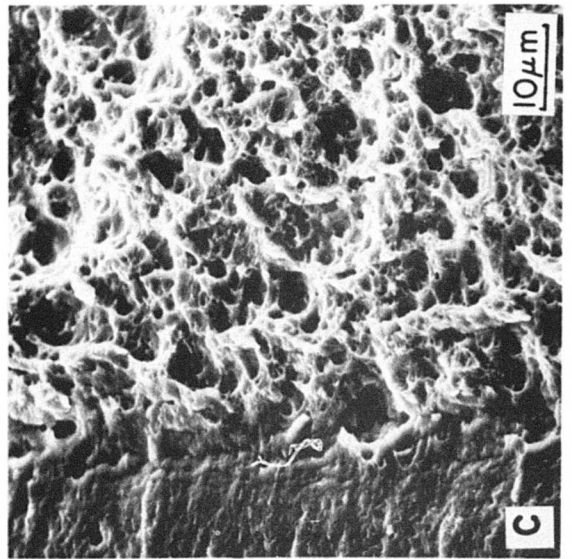
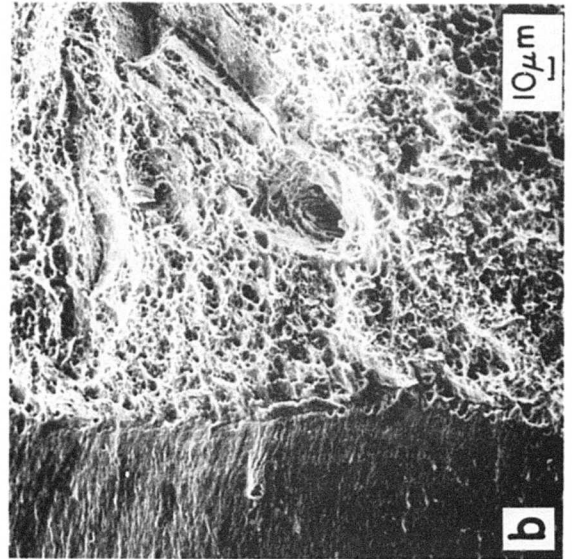

Figure 101. Alloy 253(10Mo-8V-2.5Al), sample 3C3Y1. Solution treated 1275F-4 hr WQ, single aged 950F-96 hr. SEM of fracture surface (a) X25, (b) X300, (c) X1200 - precrack/fast fracture transition, (d) X1200 - fast fracture.

YS(ksi): 157, RA(%): 33, K_Q (ksi/in): 104

DCP → S
 ↑ R



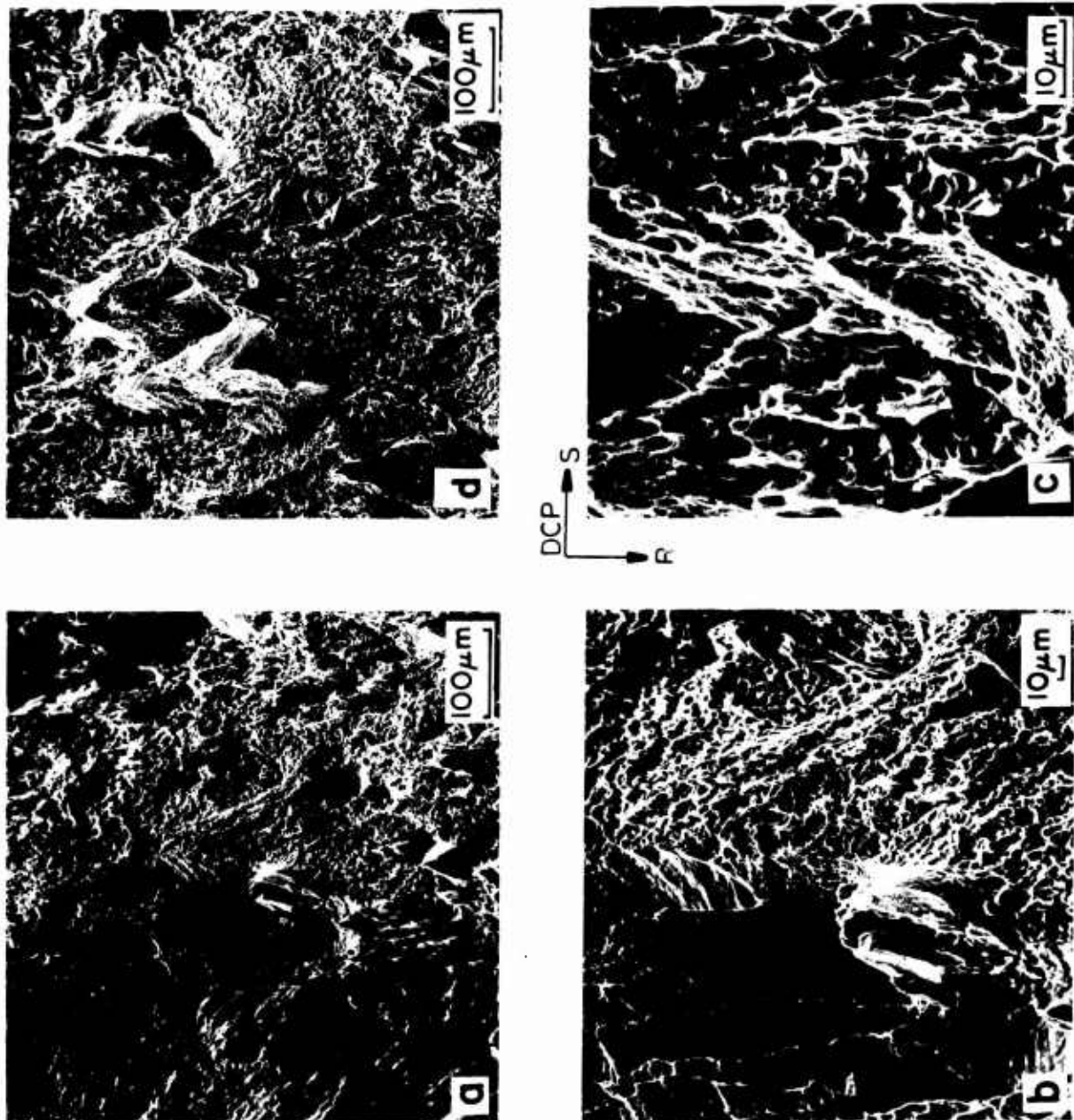

Figure 102 . Alloy 253(10Mo-8V-2.5Al), sample 3C3Z1.
 Solution treated 1275F-4 hr WQ, duplex aged 750F-8 hr +
 900F-8 hr. SEM of fracture surface (a) X120, (b) X300 -
 precrack/fast fracture transition, (c) X1200, (d) X120 -
 fast fracture.
 YS(ksi): 170, RA(%): 22, K_{Ic} (ksi/in: 75.

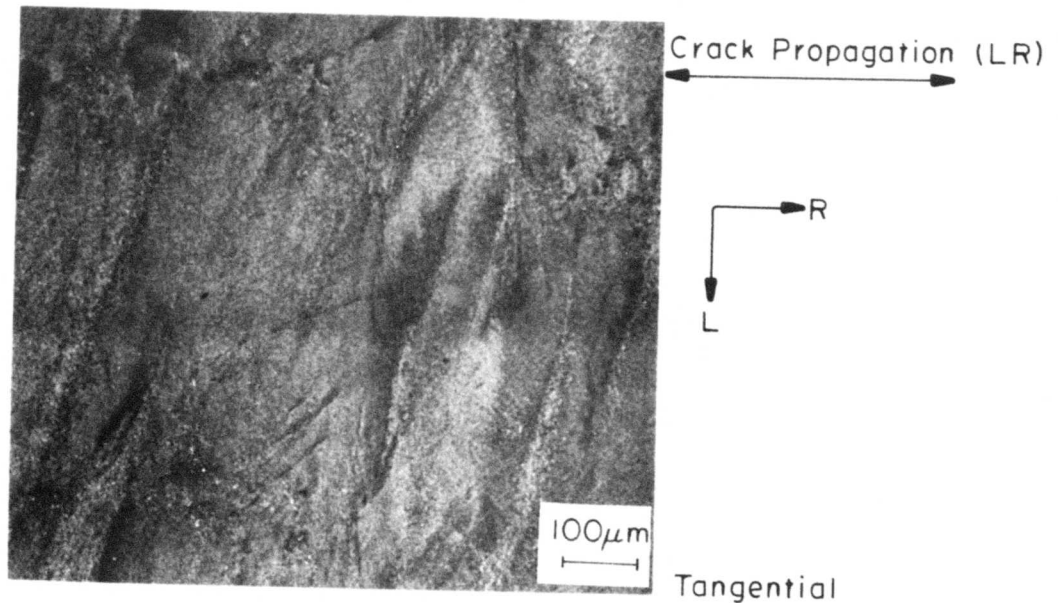
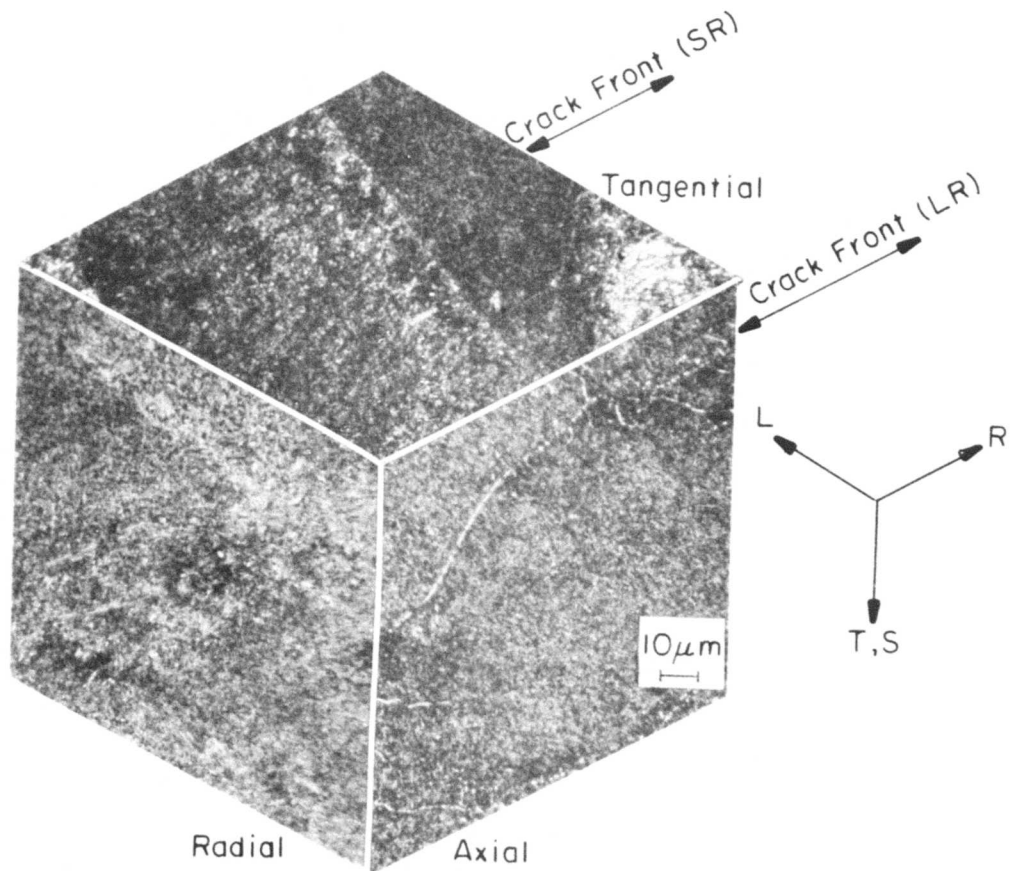

Figure 103. Alloy 334(10Mo-6Cr-2.5Al), six inch billet slice, samples 4ELR10 and 4ESR2 (Table XLVII). Solution treated 1300F-4 hr WQ, aged 900F-96 hr. Isometric X500, tangential face X100.

YS(ksi):	183 (L)	RA(%):	15 (L)	K (ksi/in):	84 (LR)
	185 (T)		4 (T)		57 (SR)

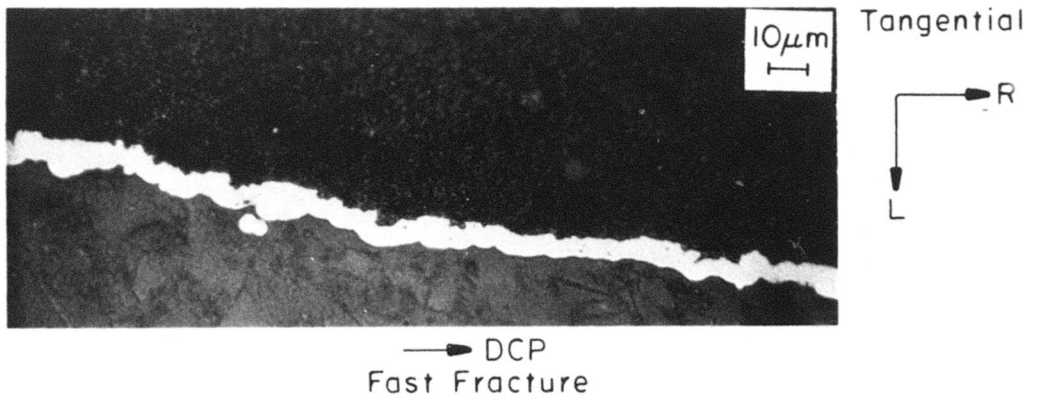
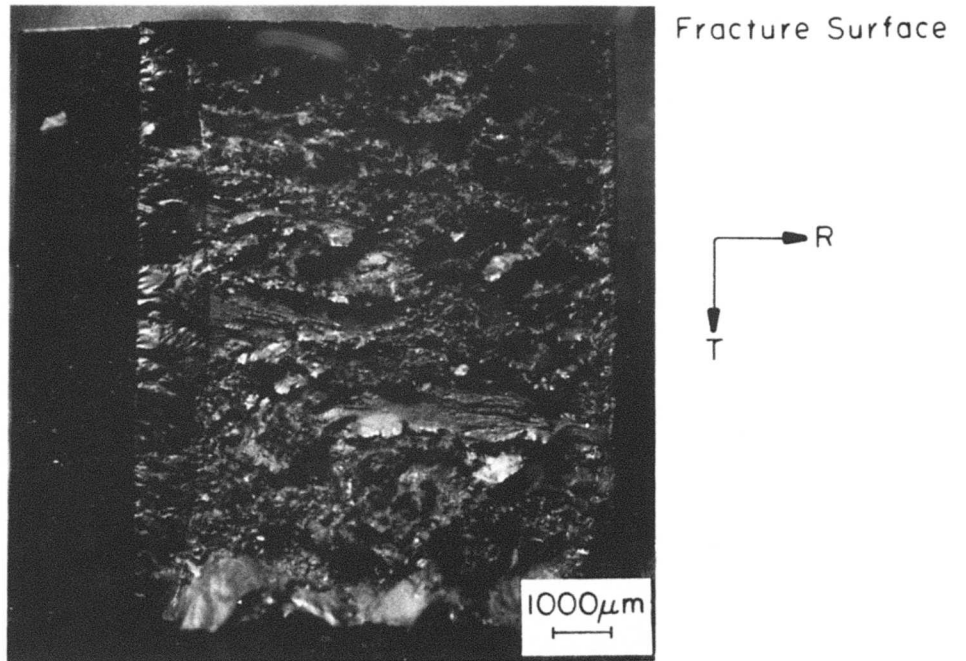

Figure 104 . Alloy 334, sample 4ELR10. Fracture surface X8, crack path X500.

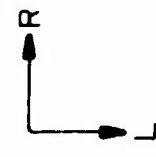
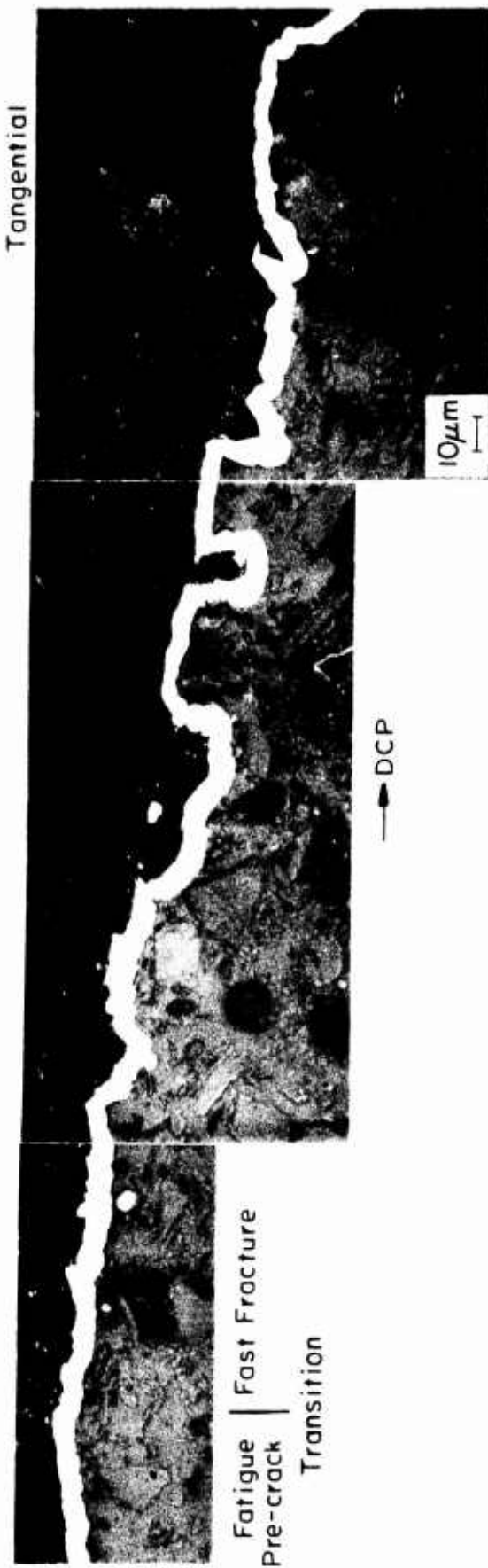
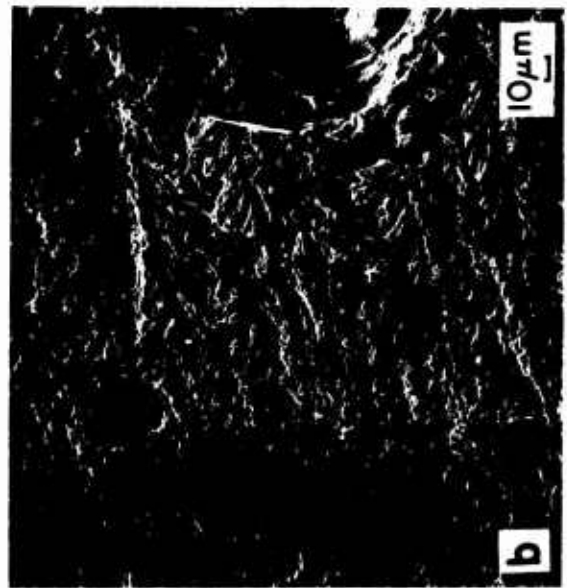
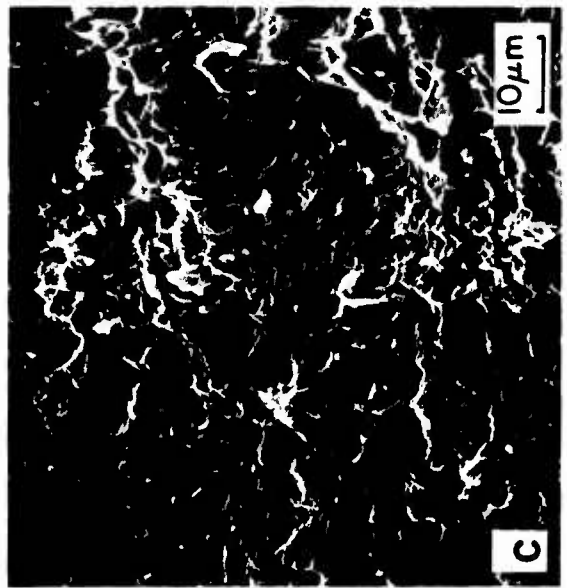
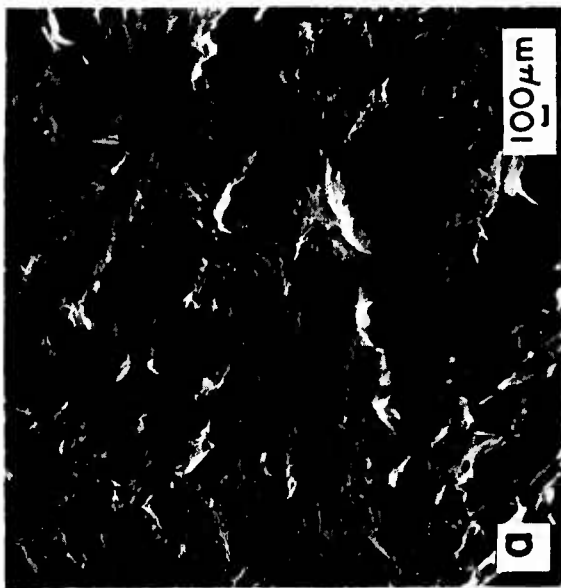

Figure 105 . Alloy 334, sample 4ELR10, X500.



DCP → R
↑ T

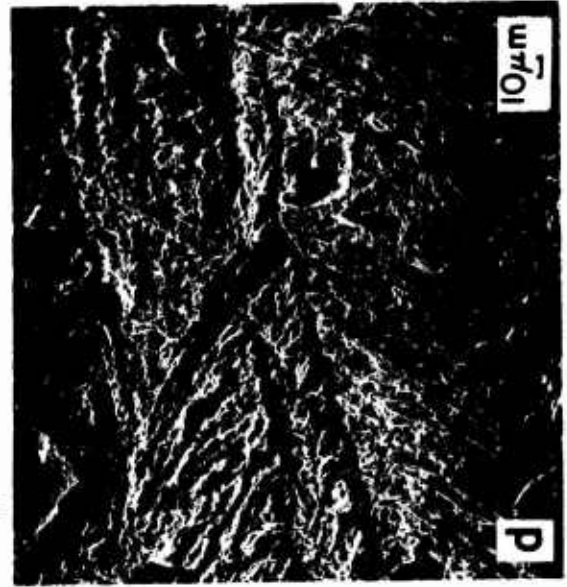
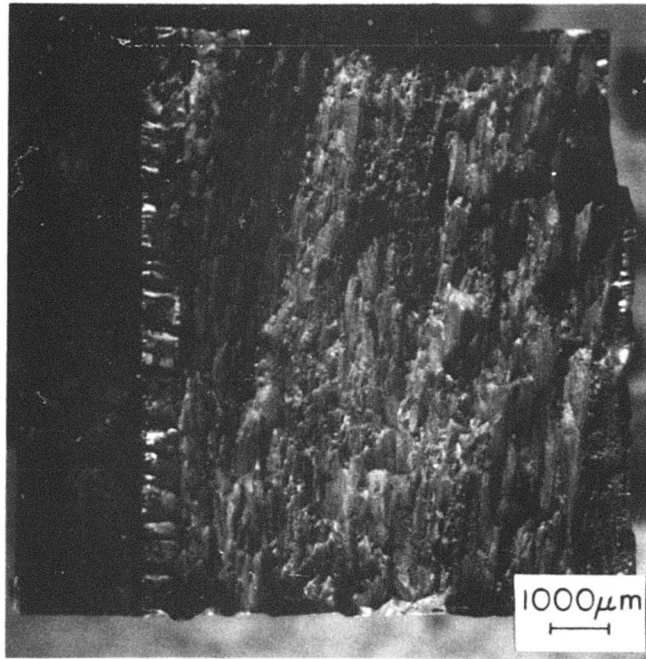
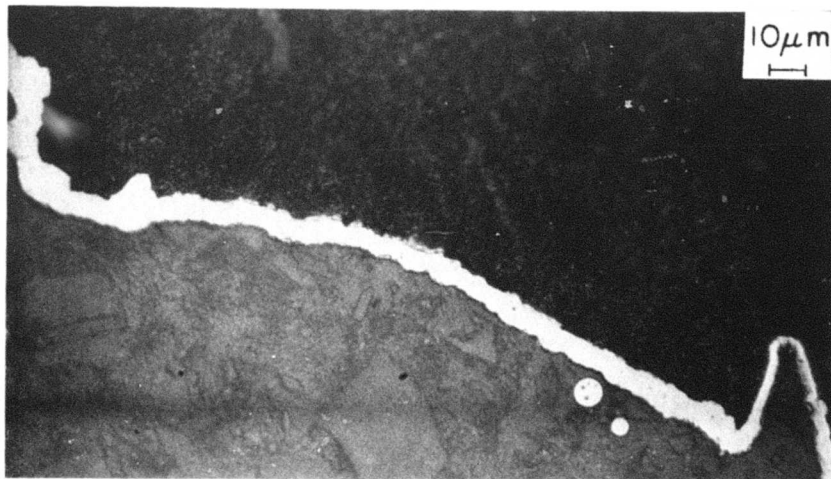
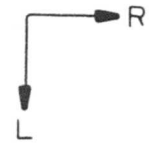

Figure 106. Alloy 334, sample 4ELR10. SEM of fracture surface (a) X25, (b) X300, (c) X1000 - precrack/fast fracture transition, (d) X250 - fast fracture.



Fracture Surface



Axial

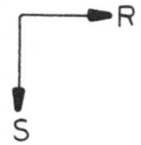

→ DCP
Fast Fracture

Figure 107 . Alloy 334, sample 4ESR2. Fracture surface X8, crack path X500.

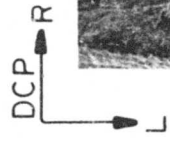
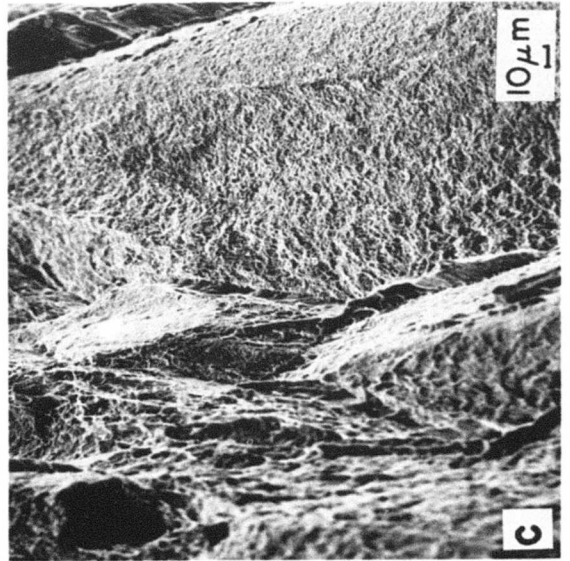
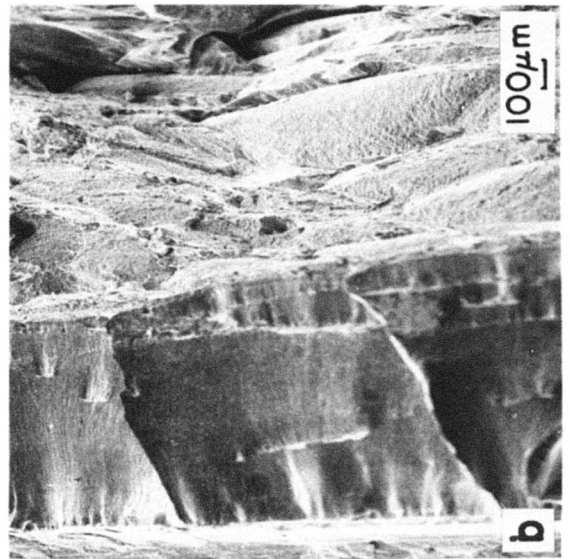
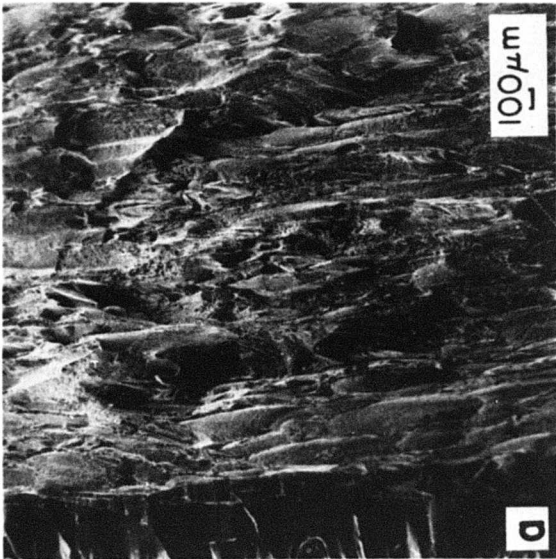
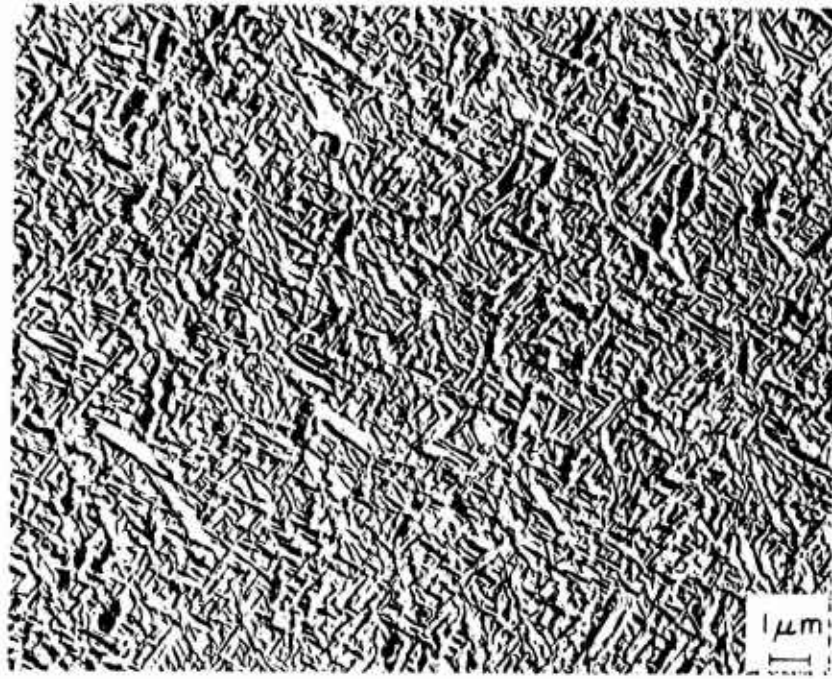
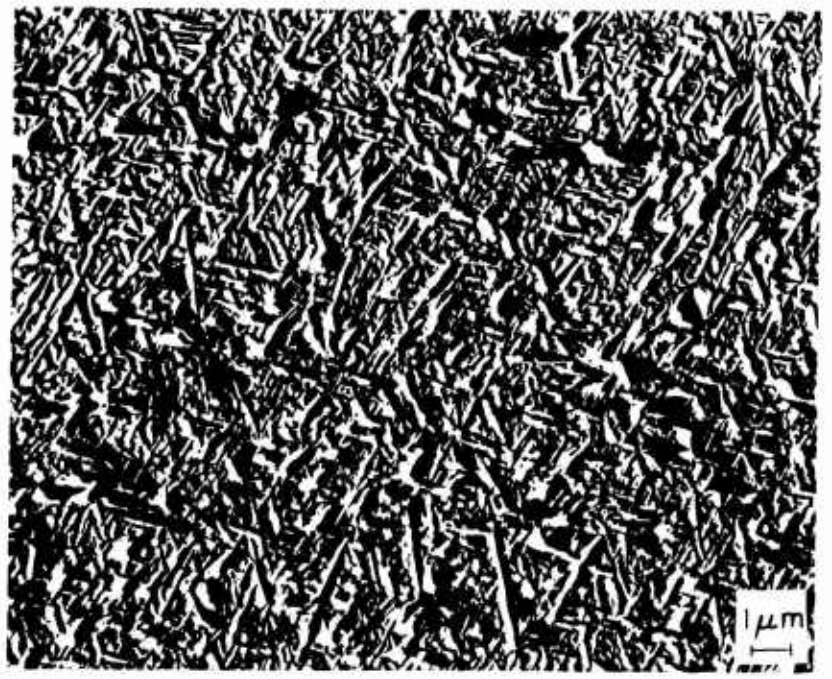
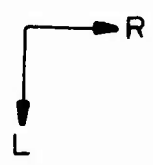

Figure 108. Alloy 334, sample 4ESR2. SEM of fracture surface (a) X25, (b) X40 - precrack/fast fracture transition, (c) X300 - fast fracture close to transition, (d) X100 - fast fracture.



Tangential



Axial

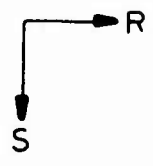

Figure 109 . Alloy 334 surface replicas X5200 (top) sample 4ELR10, (bottom) sample 4ESR2.

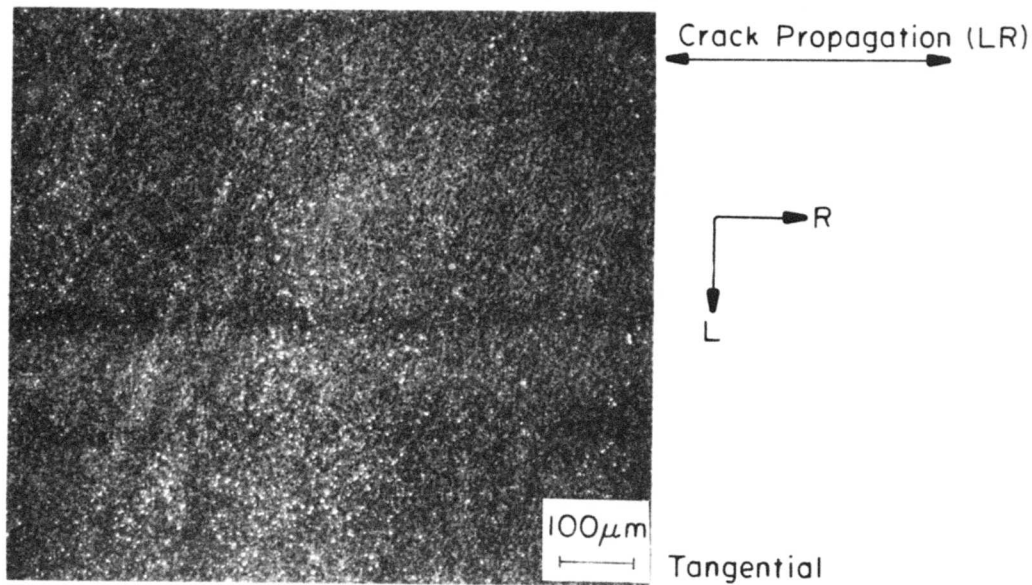
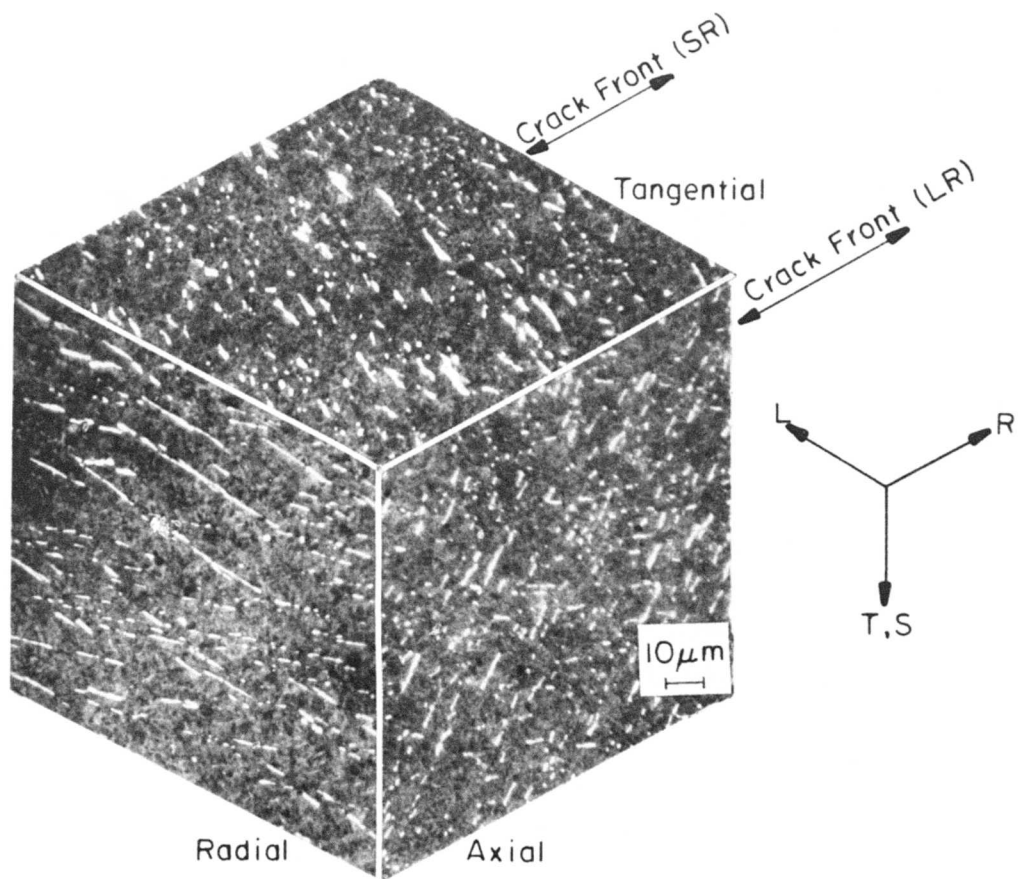

Figure 110 . Alloy 227(7Mo-4Cr-2.5Al) six inch billet slice, samples 7ELR11 and 7ESR3 (Table XLVIII). Solution treated 1475F-2 hr WQ, aged 1025F-8 hr. Isometric X500, tangential face X100.

YS(ksi):	174 (L)	RA(%):	24 (L)	K _Q (ksi/in):	59 (LR)
	171 (T)		12 (T)		51 (SR)

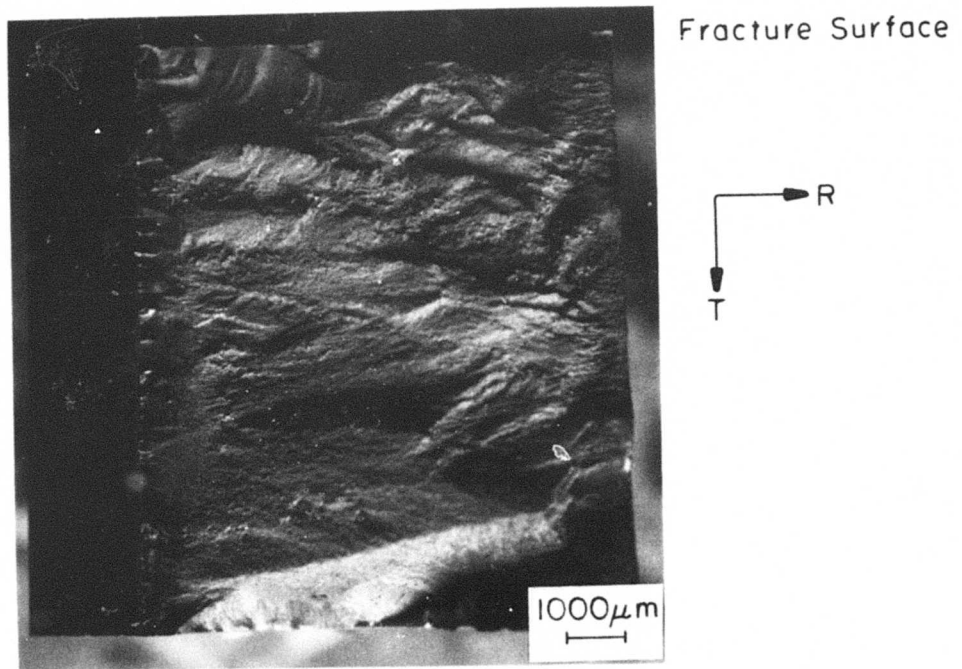
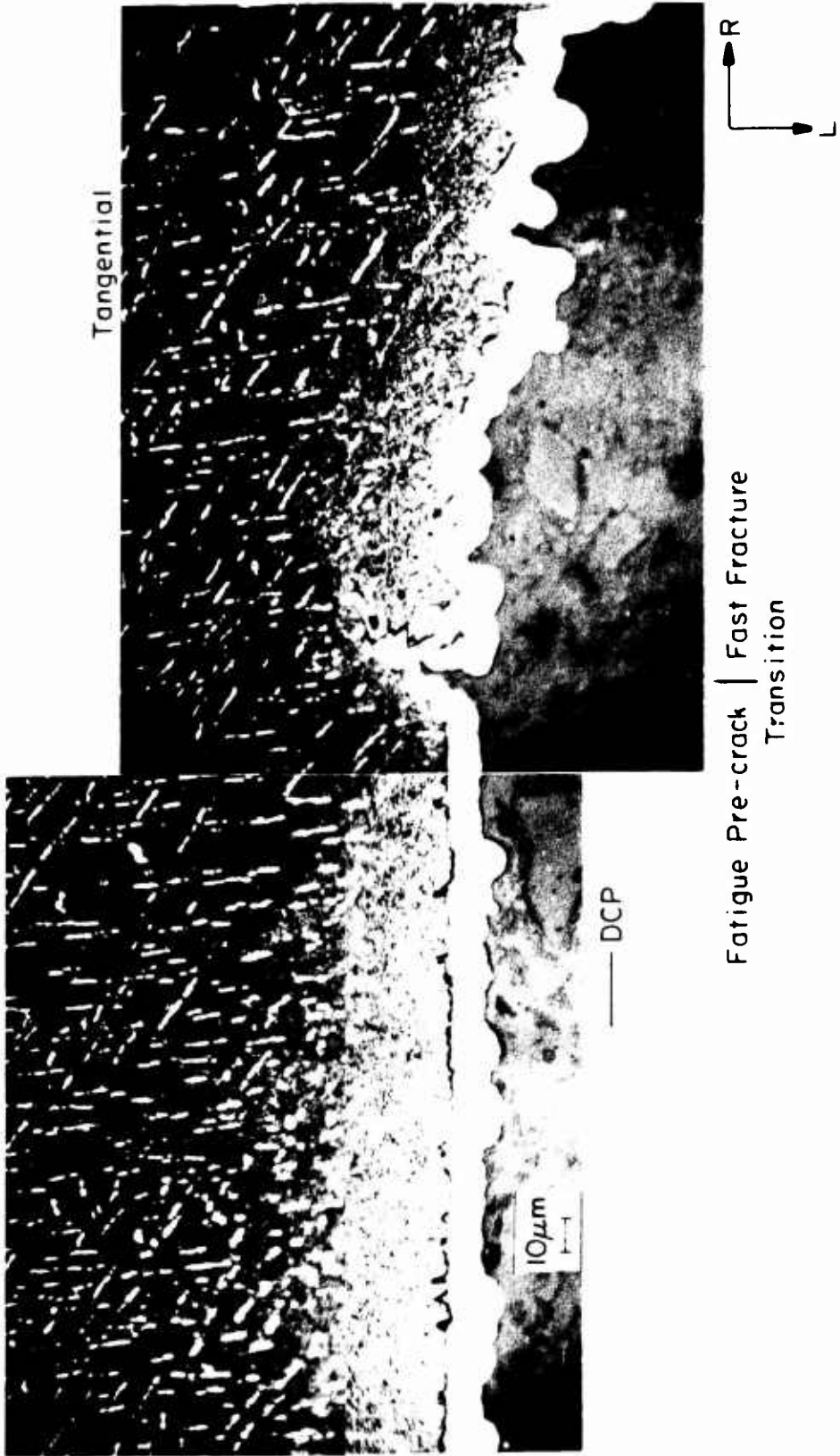

Figure 111 . Alloy 227, sample 7ELR11. Fracture surface X8.



Fatigue Pre-crack | Fast Fracture
Transition

Figure 112. Alloy 227, sample 7ELR11, X500.

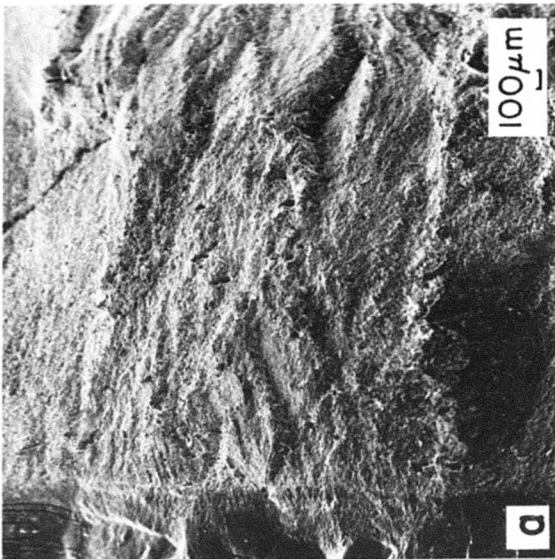
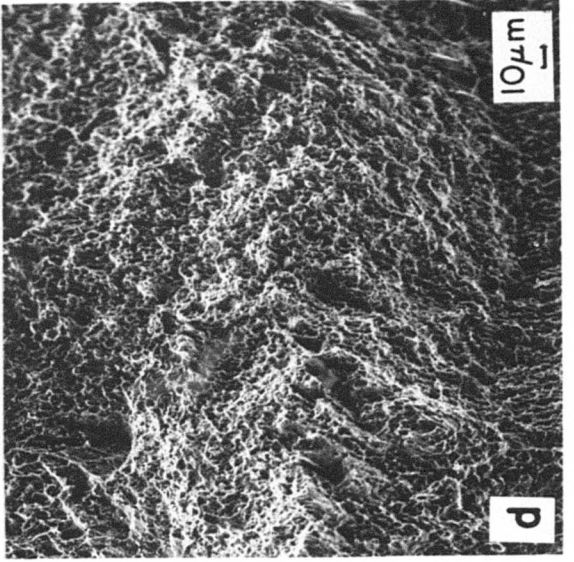
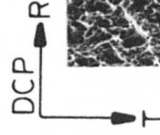
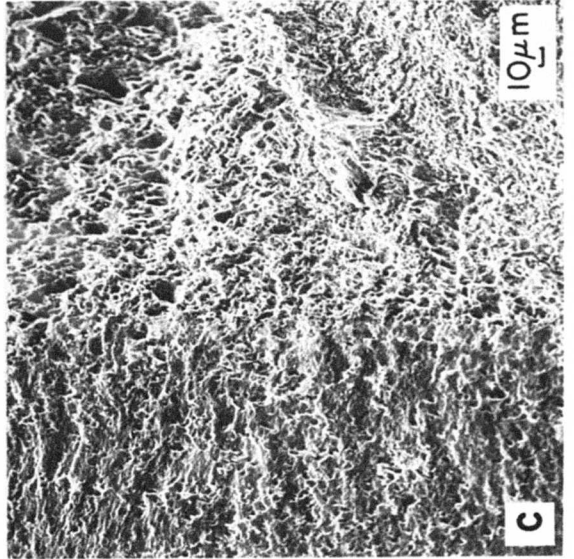
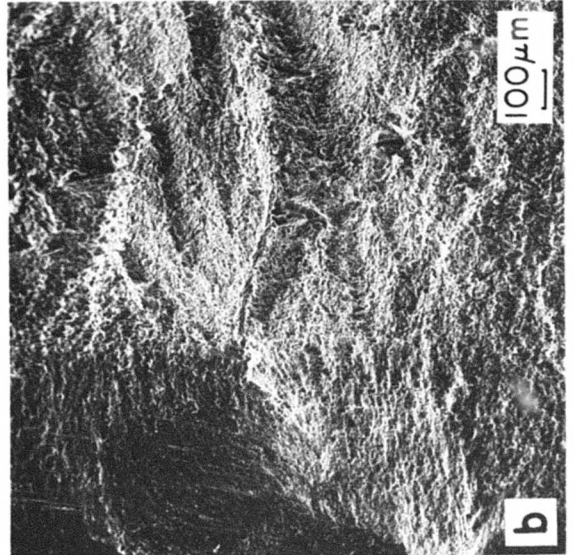

Figure 113 . Alloy 227, sample 7ELR11. SEM of fracture surface (a) X25, (b) X50, (c) X250 - precrack/fast fracture transition, (d) X300 - fast fracture.



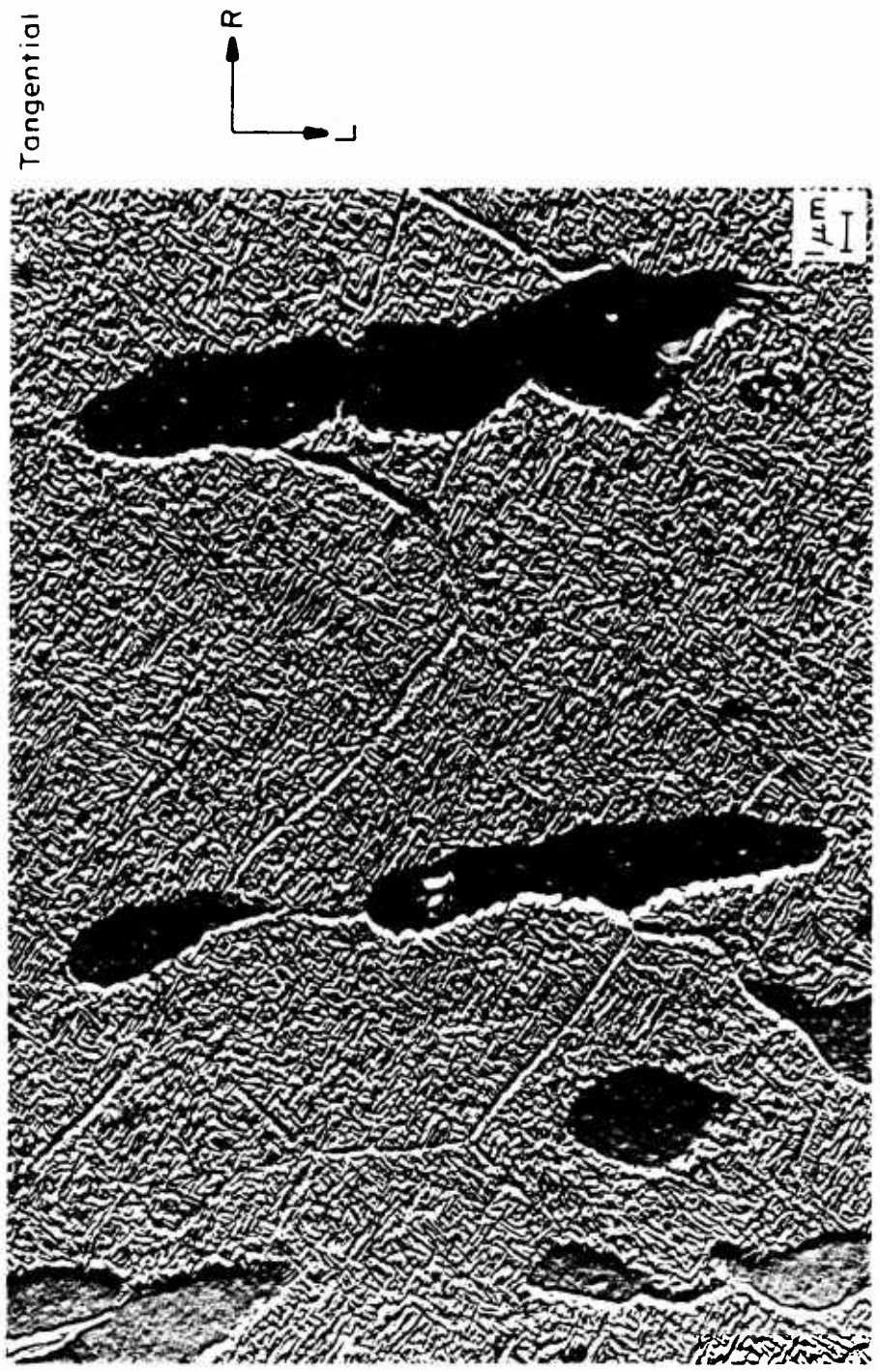

Figure 114. Alloy 227, sample 7ELR11, surface replica X5200.

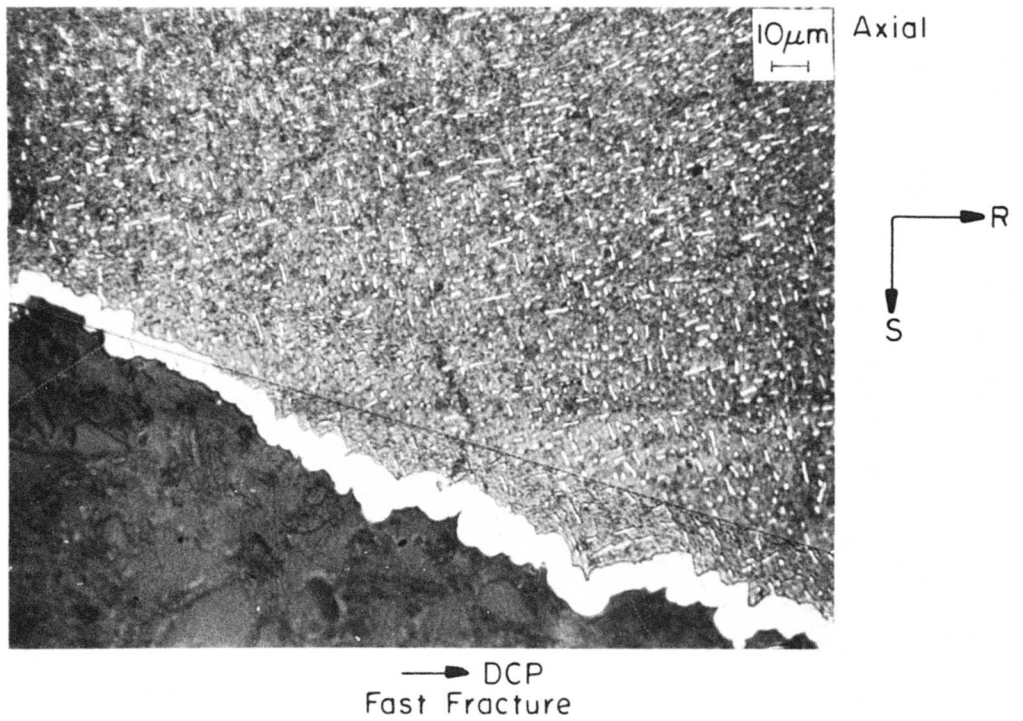
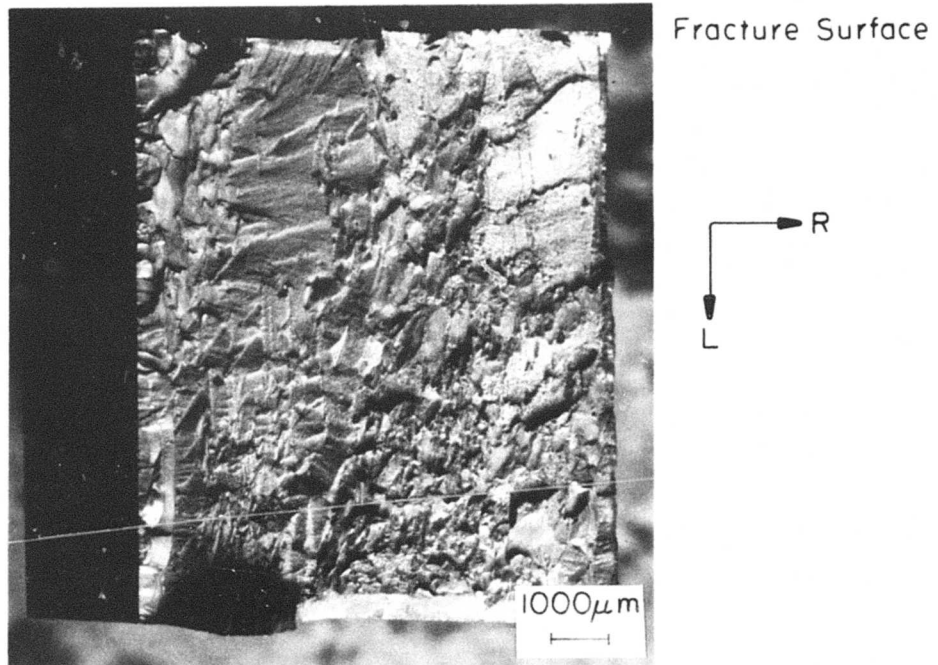
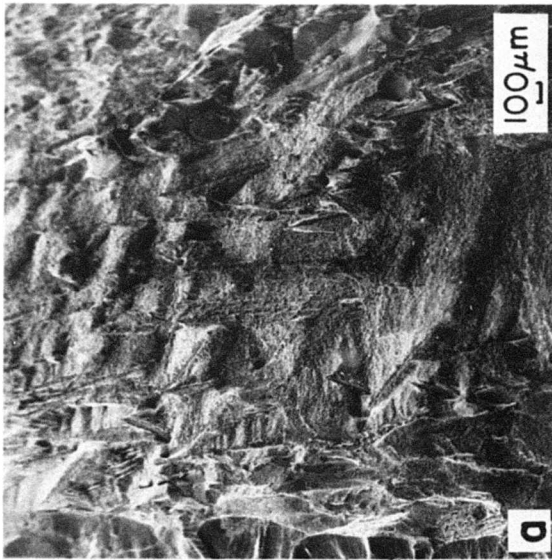

Figure 115. Alloy 227, sample 7ESR3. Fracture surface X8, crack path X500.



DCP → R
L

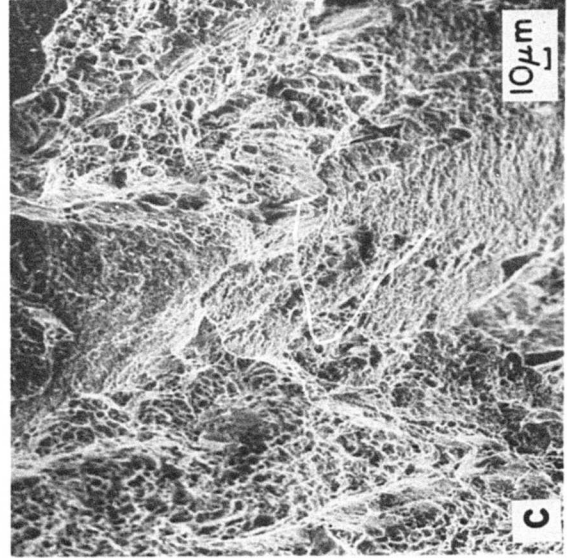
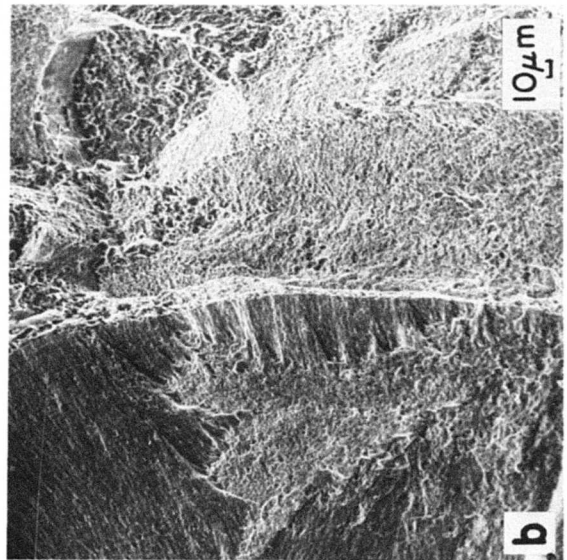

Figure 116. Alloy 227, sample 7ERS3. SEM of fracture surface (a) X25, (b) X200 - precrack/fast fracture transition, (c) X250 - fast fracture.

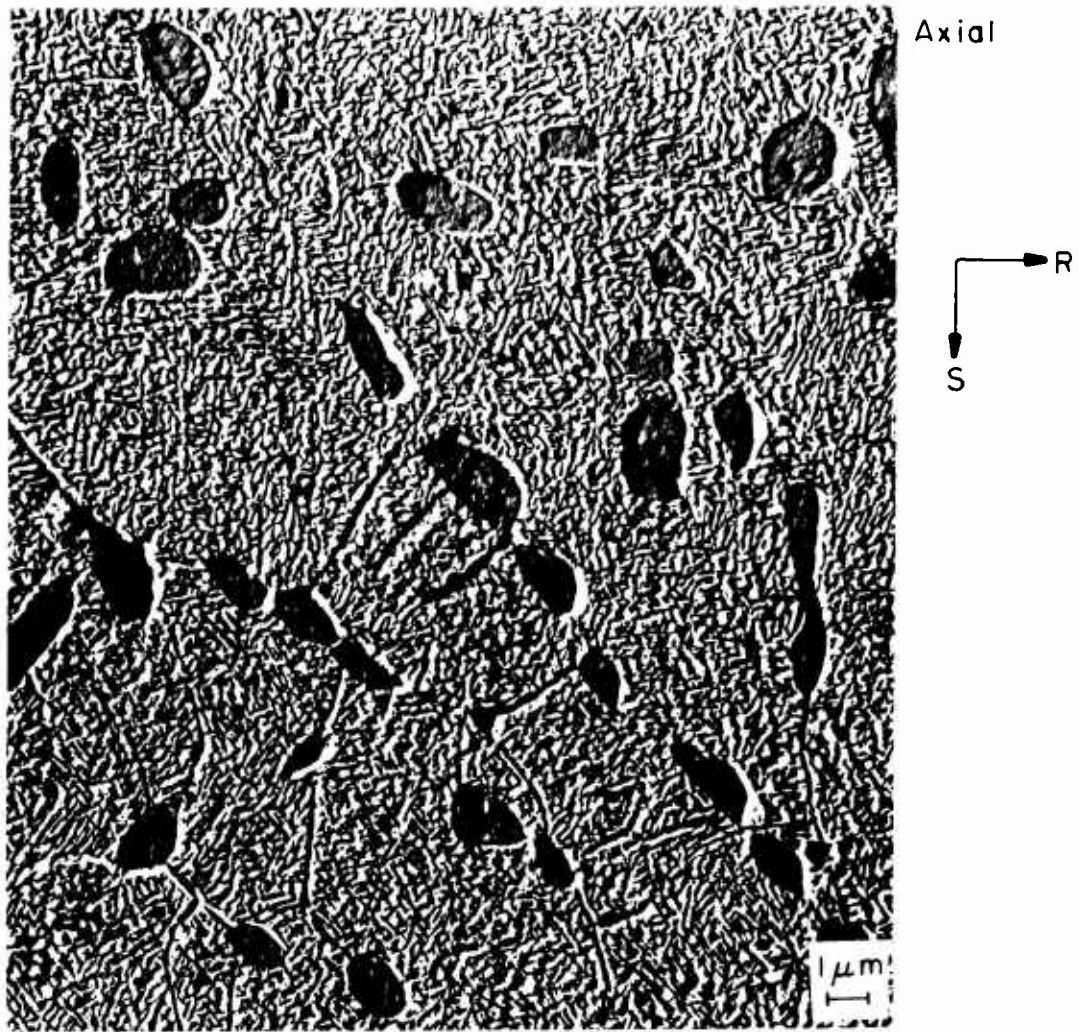

Figure 117. Alloy 227, sample 7ESR3, surface replica X5200.

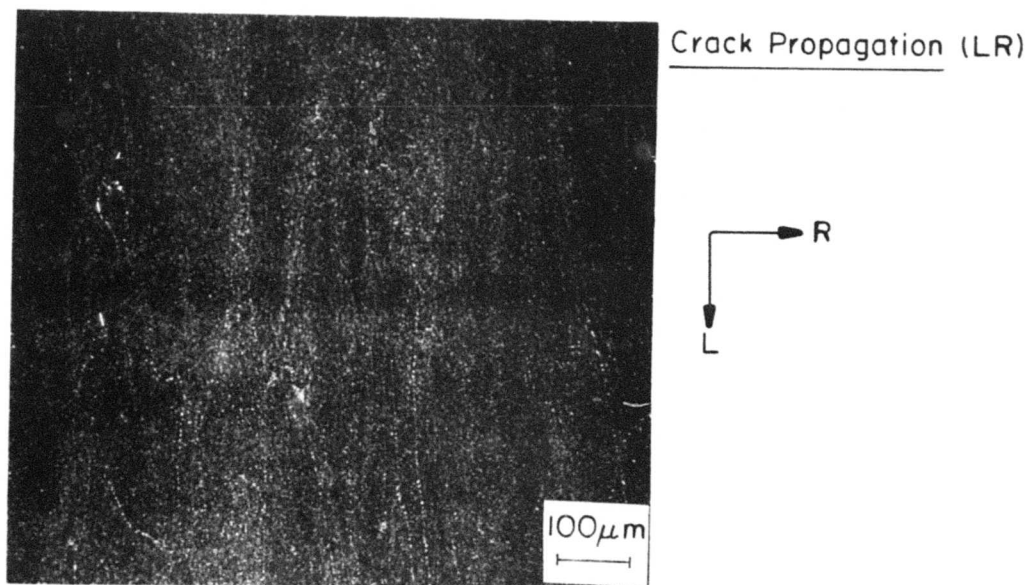
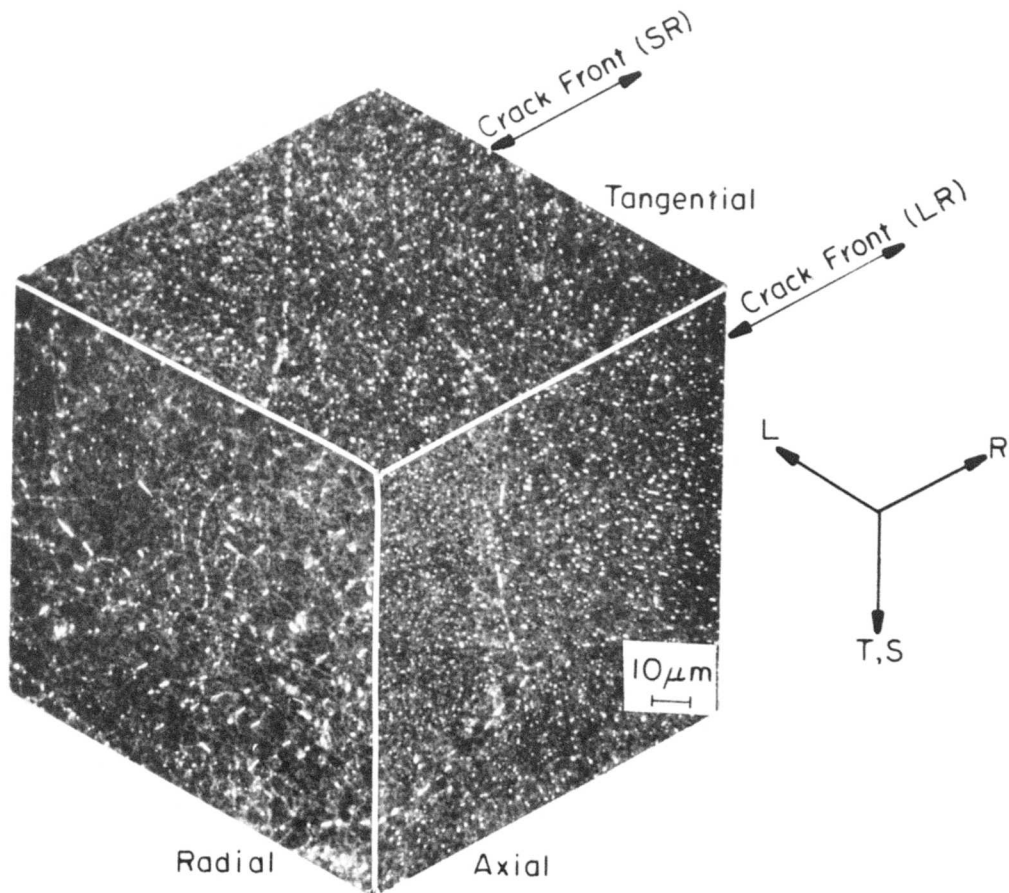
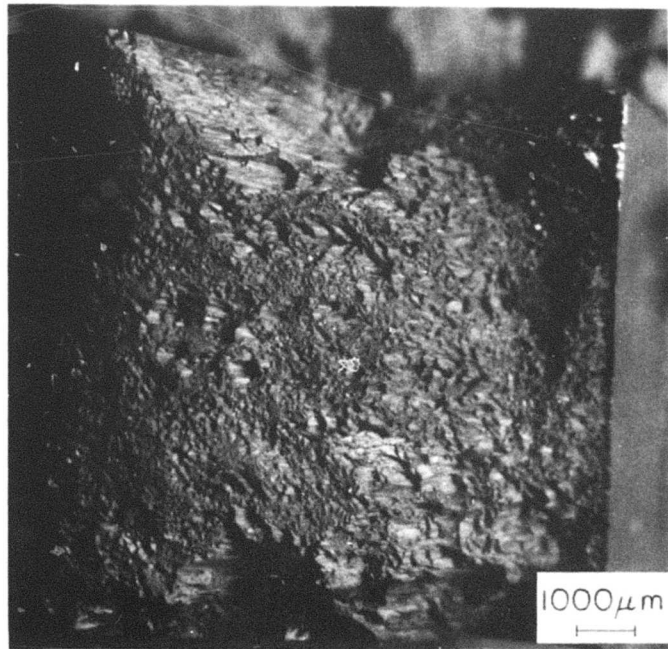
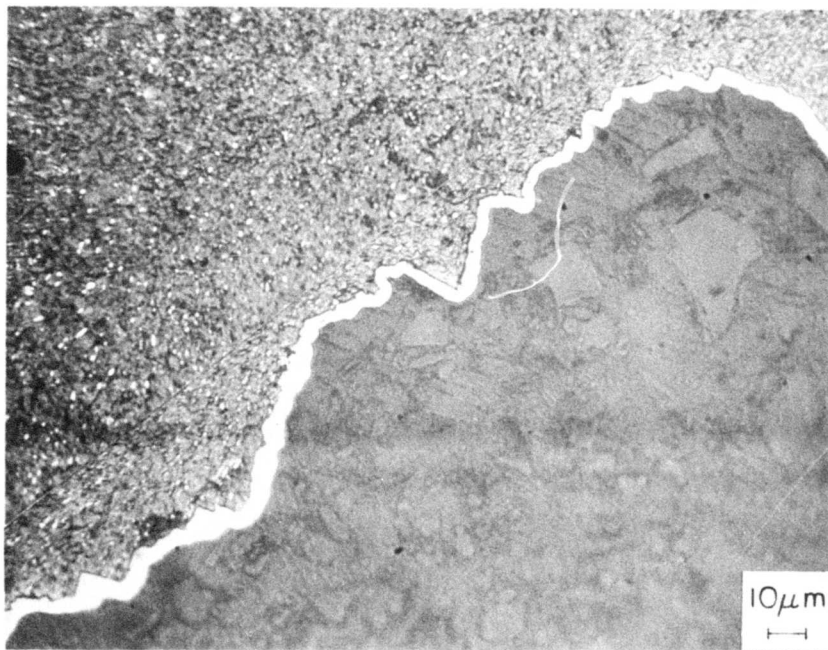
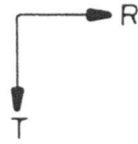

Figure 118 . Alloy 227(7Mo-4Cr-2.5Al) six inch billet slice, samples 7ELR9 and 7ESR1 (Table XLVIII). Solution treated 1475F-2 hr WQ, aged 900F-96 hr + 1050F-8 hr. Isometric X500, tangential face X100.

YS(ksi):	183 (L)	RA(%):	28 (L)	K_Q (ksi/in):	78 (LR)
	183 (T)		6 (T)		41 (SR)



Fracture Surface



Tangential

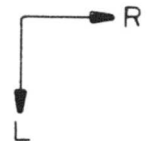

—▶ DCP
Fast Fracture

Figure 119. Alloy 227, sample 7ELR9. Fracture surface X8, crack path X500.

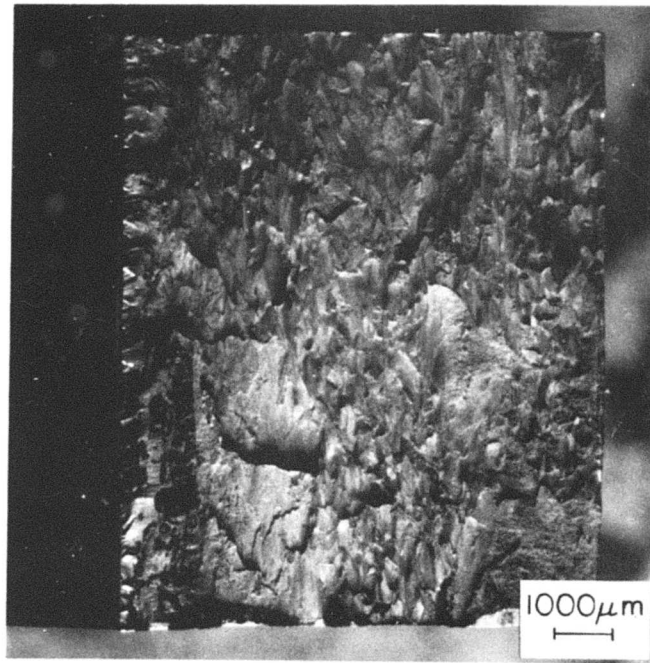

Fracture Surface

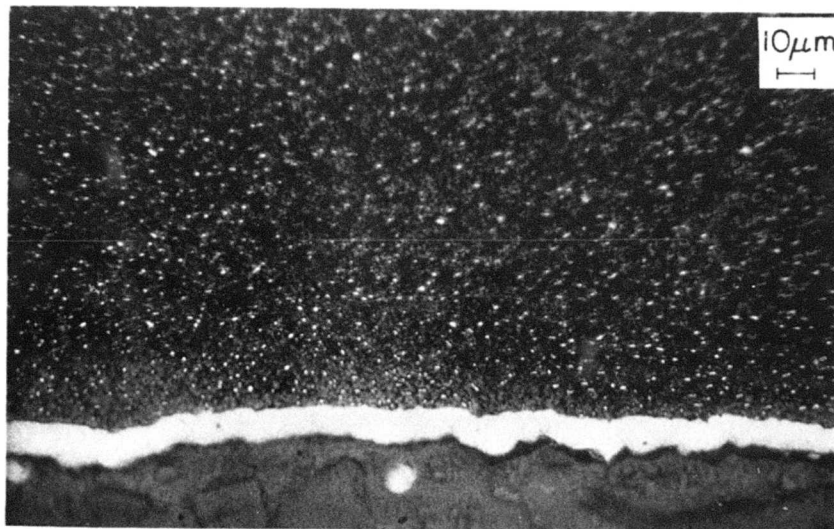
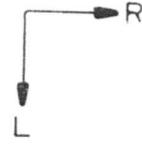

Axial



→ DCP
Fast Fracture

Figure 120 . Alloy 227, sample 7ESR1. Fracture surface X8, crack path X500.



Tangential

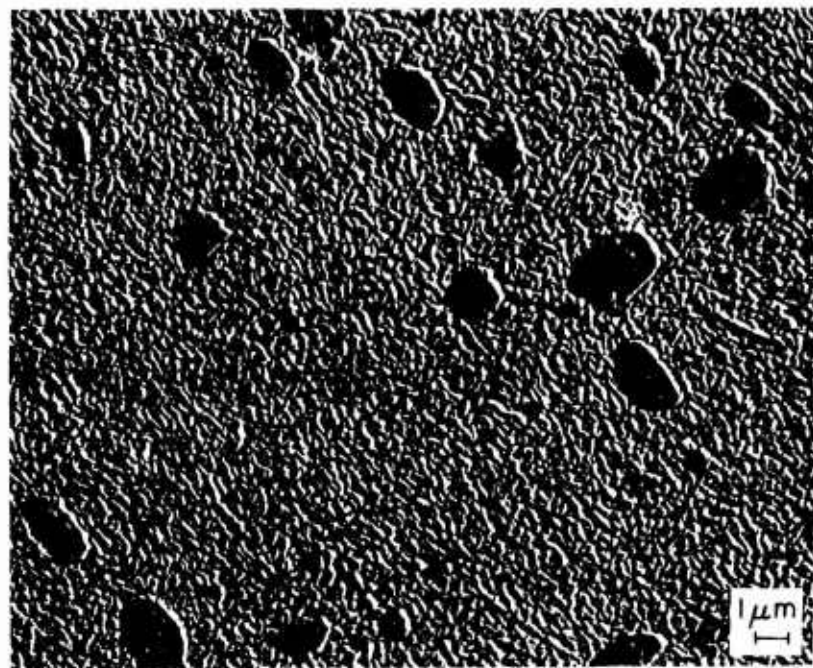
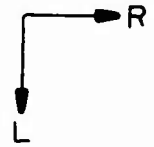

Axial

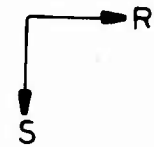

Figure 121 . Alloy 227 surface replicas X5200.
(Top) sample 7ELR9, (Bottom) sample 7ESR1.

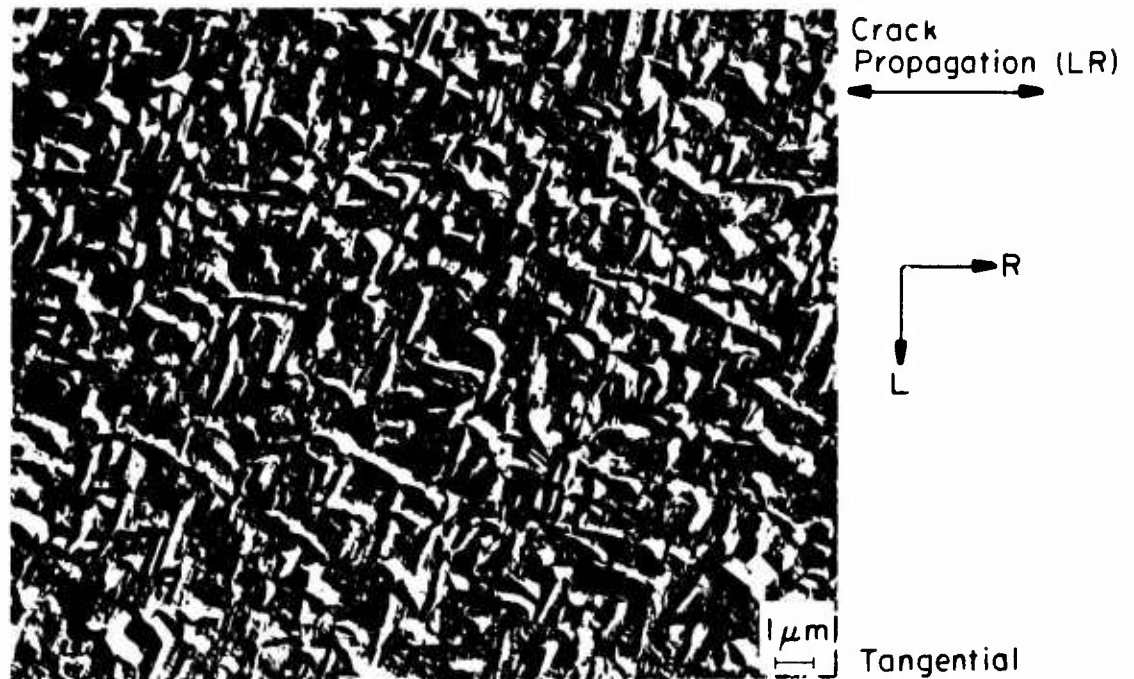
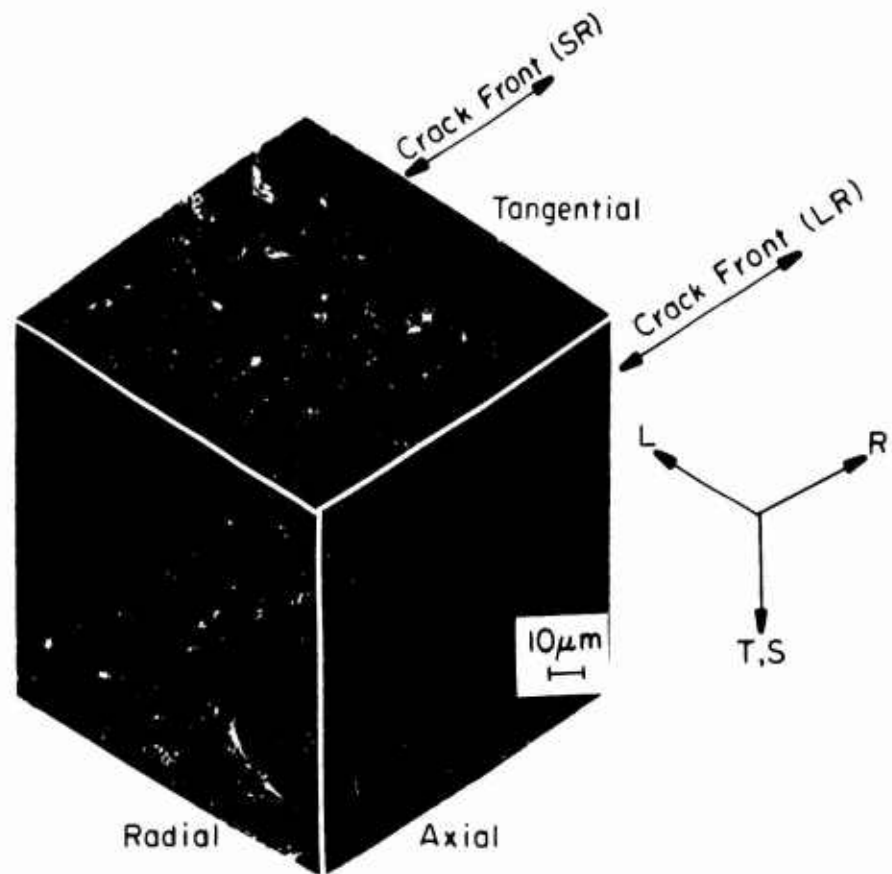
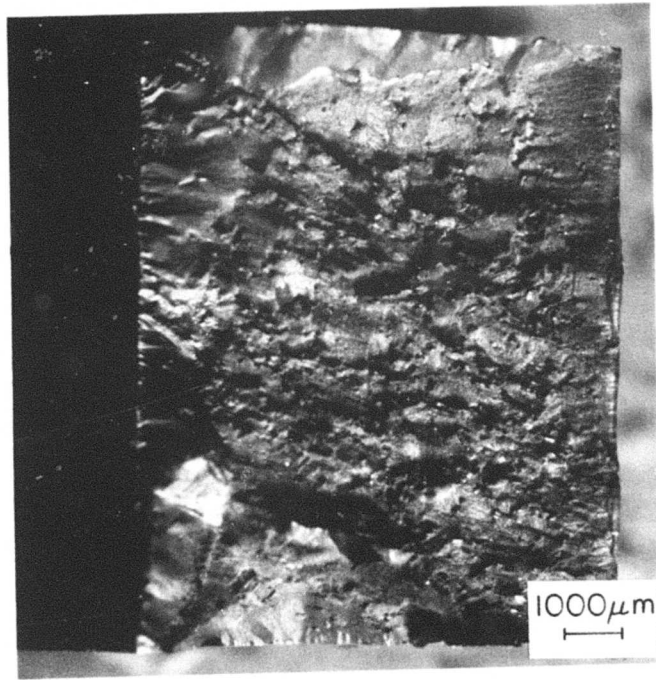
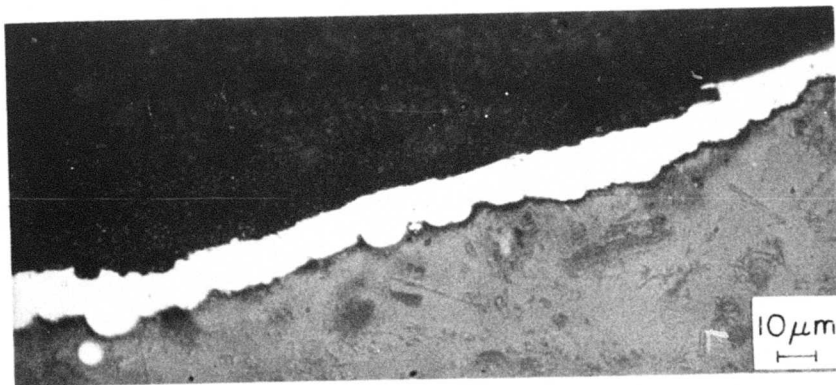
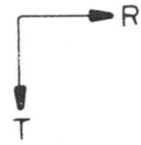

Figure 122 . Alloy 253(10Mo-8V-2.5Al) six inch billet slice, samples 3ELR10 and 3ESR2 (Table XLIV). Solution treated 1275-4 hr WQ, aged 900F-96 hr. Isometric X500, surface replica X5200.

YS(ksi):	172 (L)	RA(%):	31 (L)	K _Q (ksi/in):	78 (LR)
	167 (T)		13 (T)		48 (SR)



Fracture Surface



Tangential

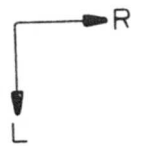

→ DCP
Fatigue Pre-crack

Figure 123 . Alloy 253, sample 3ELR10. Fracture surface X8, crack path X500.

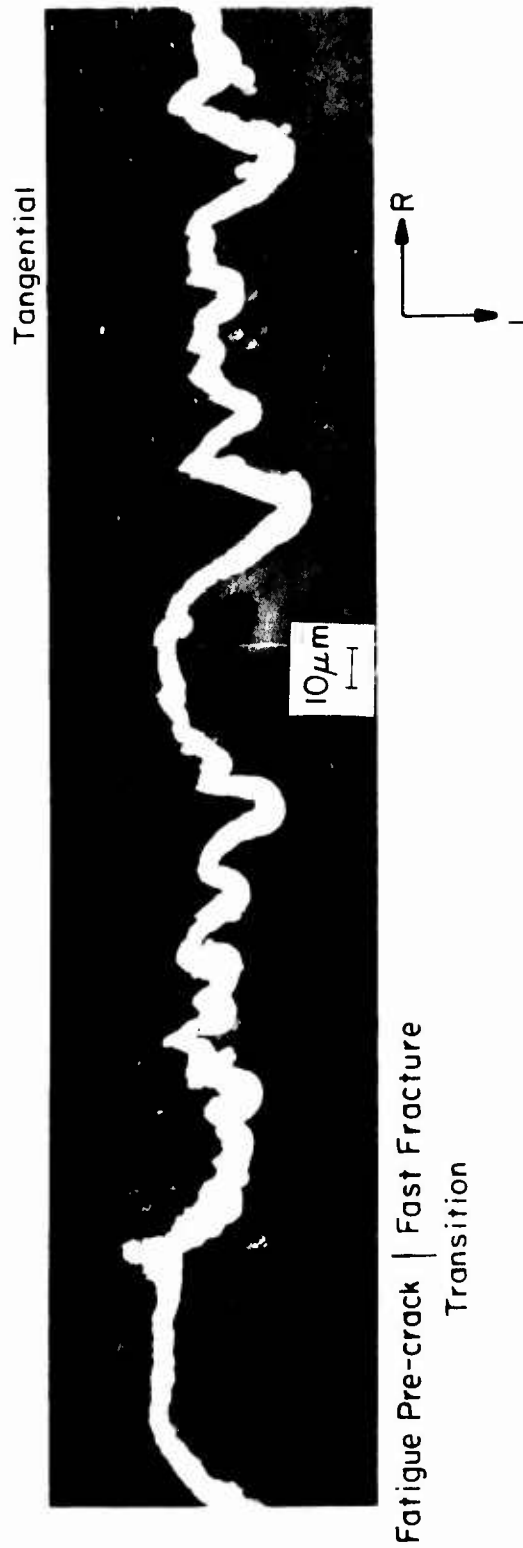

Figure 124. Alloy 253, sample 3ELR10, X500.

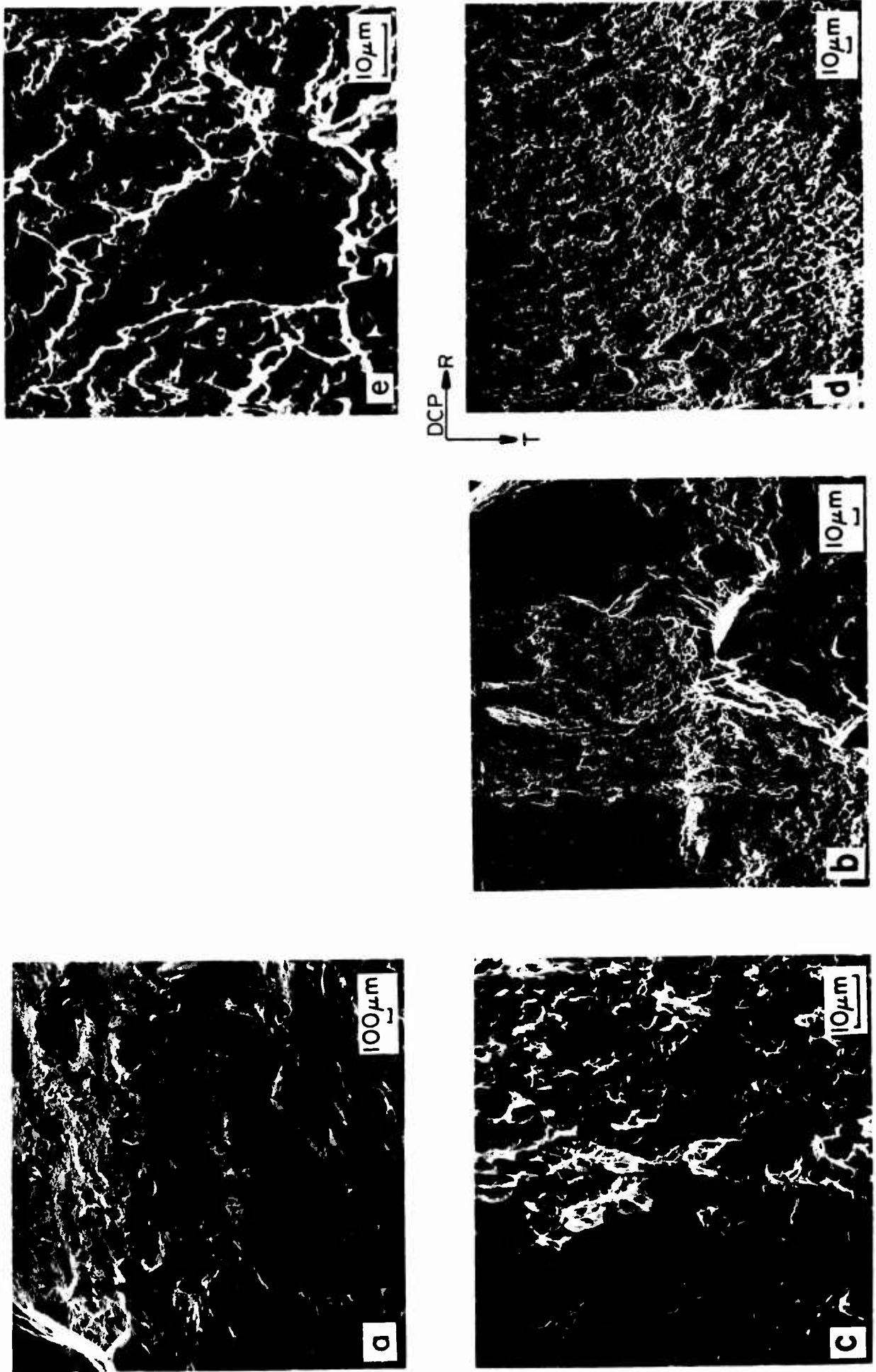

Figure 125 . Alloy 253, sample 3ELR10. SEM of fracture surface (a) X25, (b) X300, (c) X1000-
 precrack/fast fracture transition, (d) X300, (e) X1000 - fast fracture.

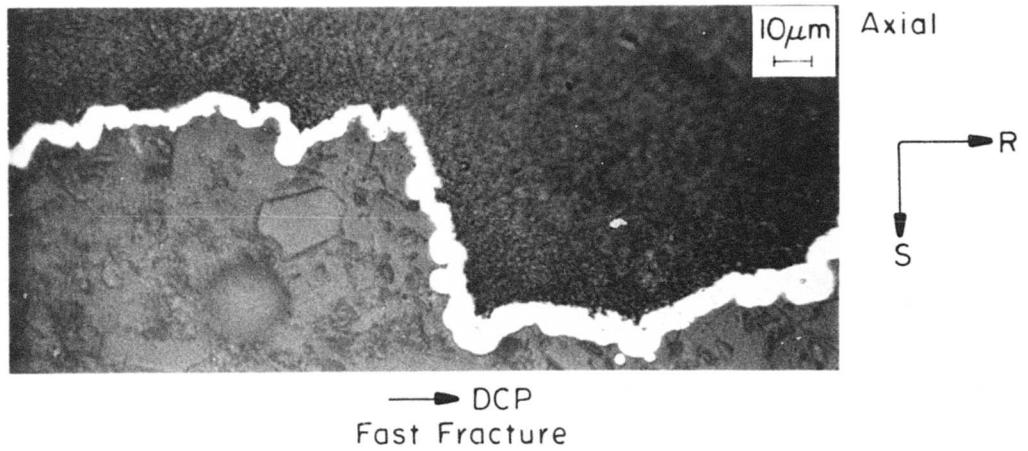
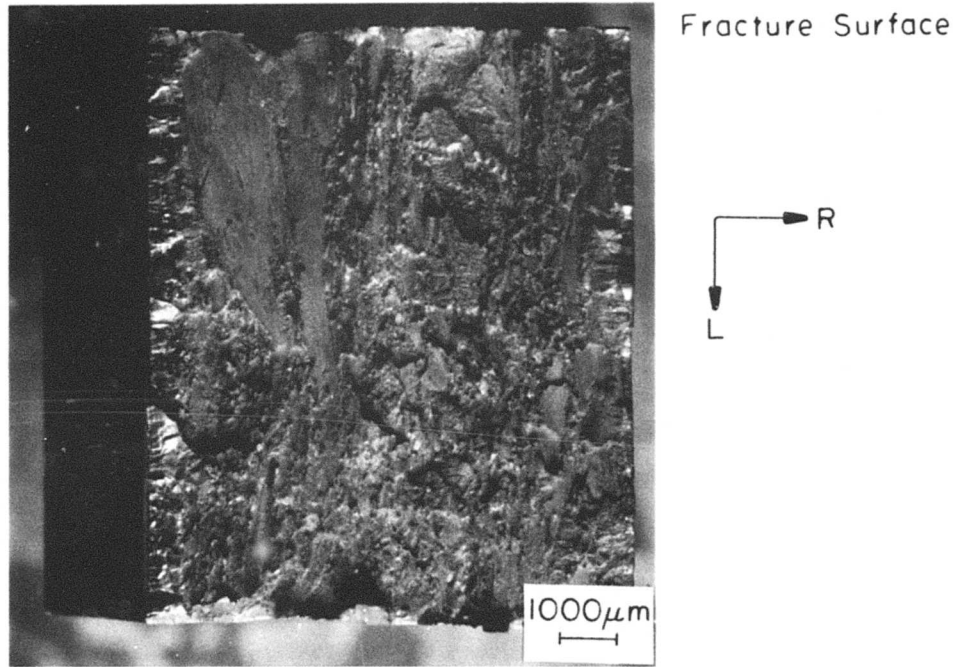
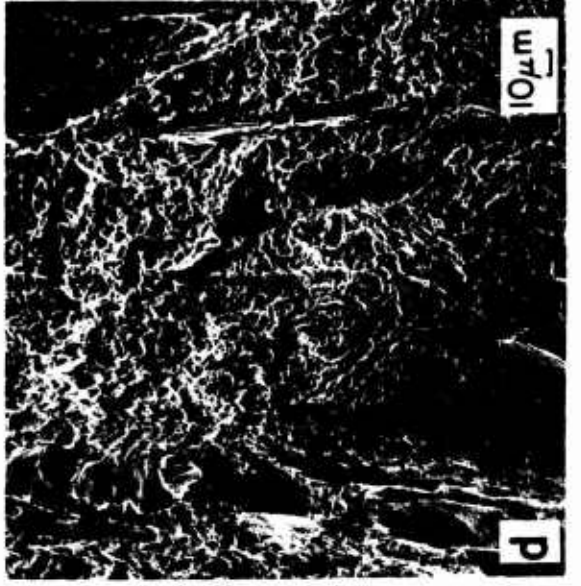
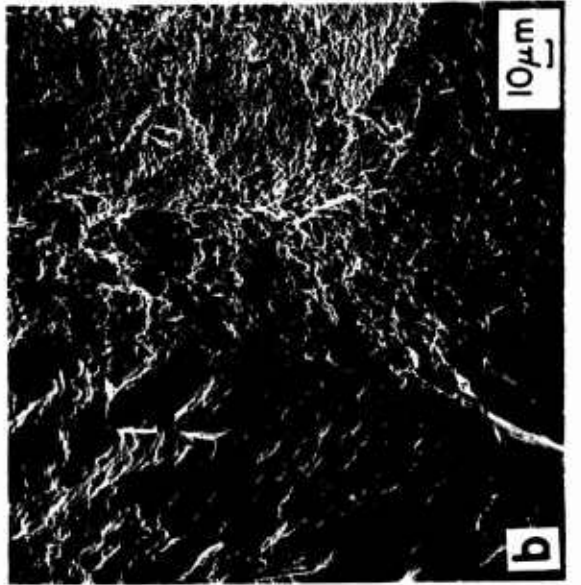
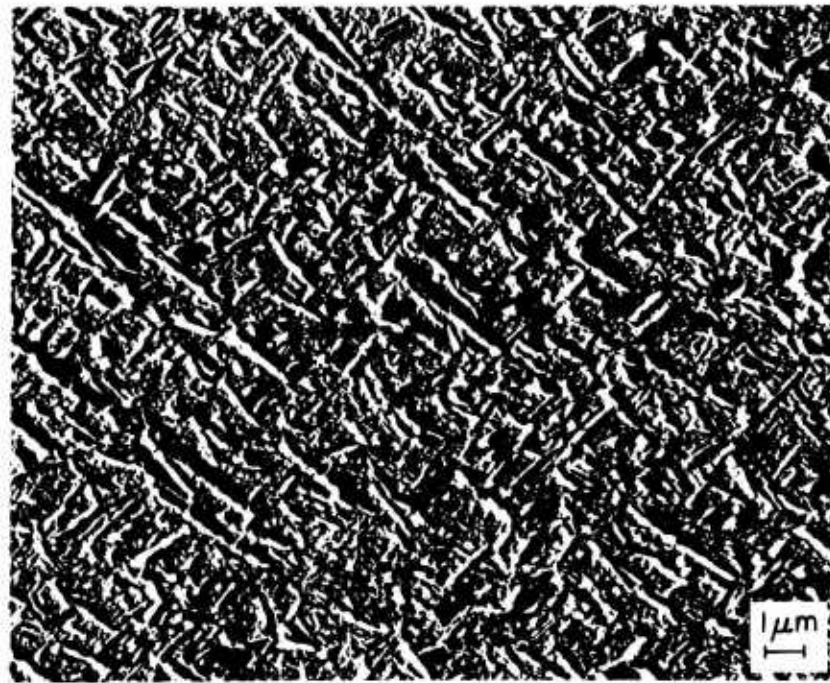

Figure 126 . Alloy 253, sample 3ESR2.
Fracture surface X8, crack path X500.



DCP R

Figure 127. Alloy 253, sample 3ESR2. SEM of fracture surface (a) X25, (b) X300, (c) X1000-
precrack/fast fracture transition, (d) X300, (e) X1000-fast fracture.



Axial



Axial

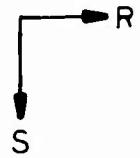

Figure 128 . Alloy 253, sample 3ESR2, (both) surface replicas X5200.

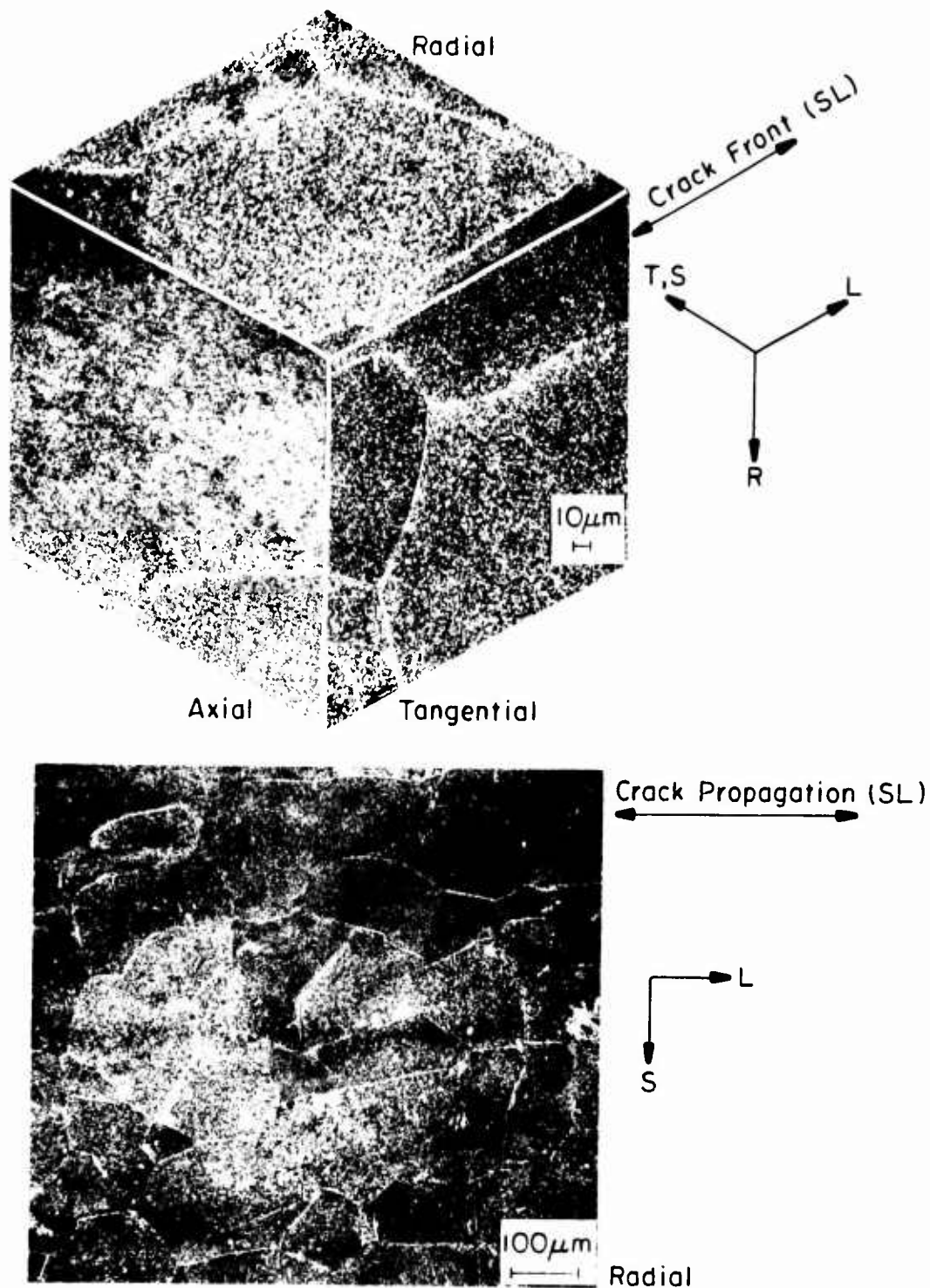
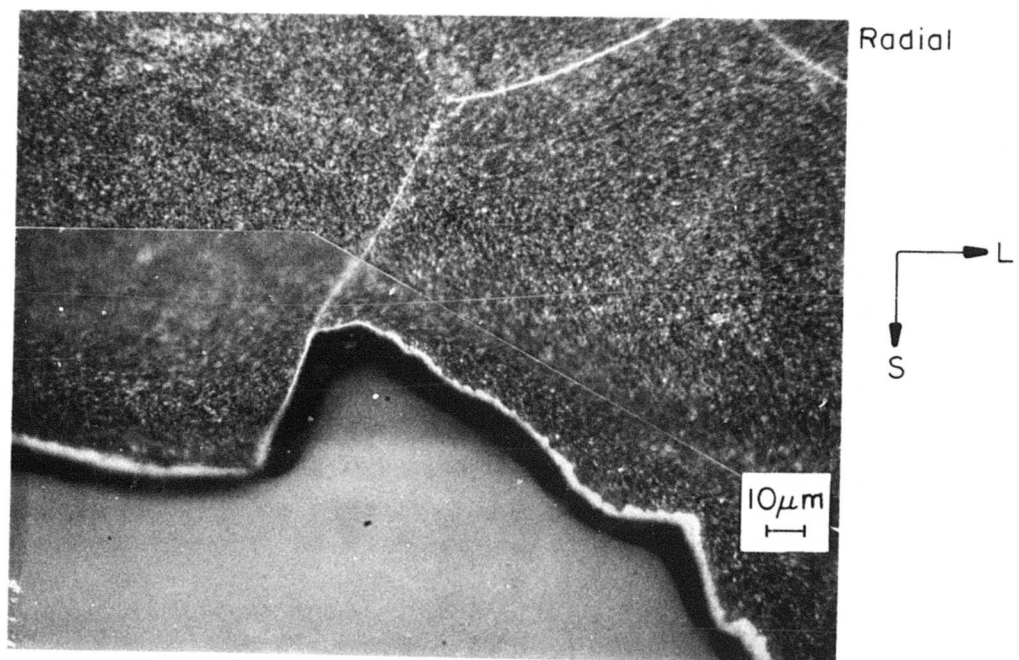
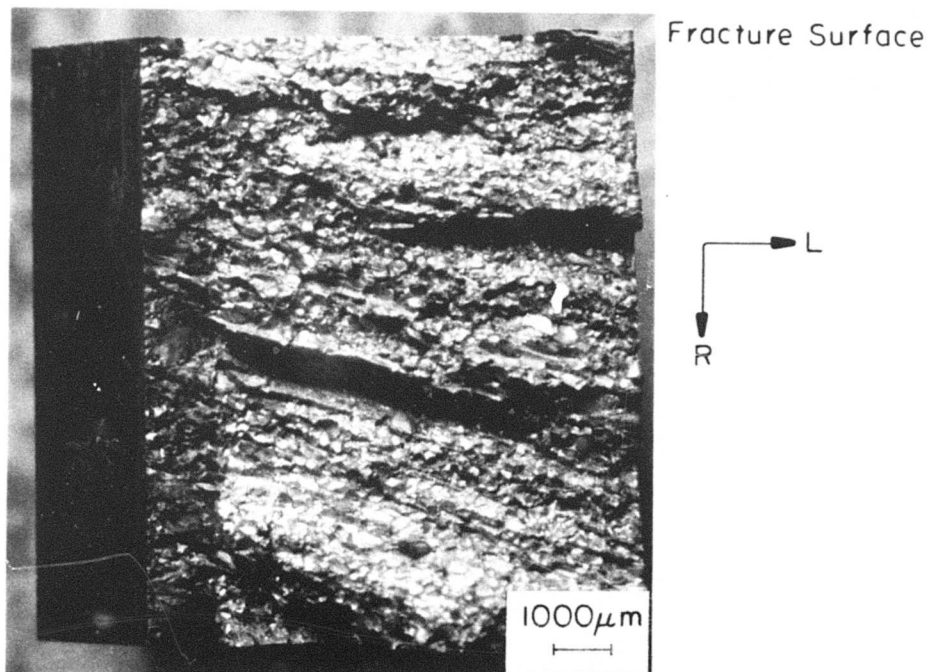

Figure 129 . Alloy 334(10Mo-6Cr-2.5Al) six inch billet slice, sample 4MSL8 (TableLIII). Recrystallize annealed 1525F-1 hr WQ, solution annealed 1300F-4 hr WQ, aged 900F-96 hr. Isometric X250, radial face X100.

YS(ksi):	167 (L)	RA(%):	14 (L)	KQ(ksi/in):	58 (LR)
	178 (T)		6 (T)		45 (SL)



—► DCP
Fast Fracture

Figure 130. Alloy 334, sample 4MSL8. Fracture surface X8, crack path X500. Note faceted appearance of fracture surface, mixed mode transgranular/intergranular crack propagation.

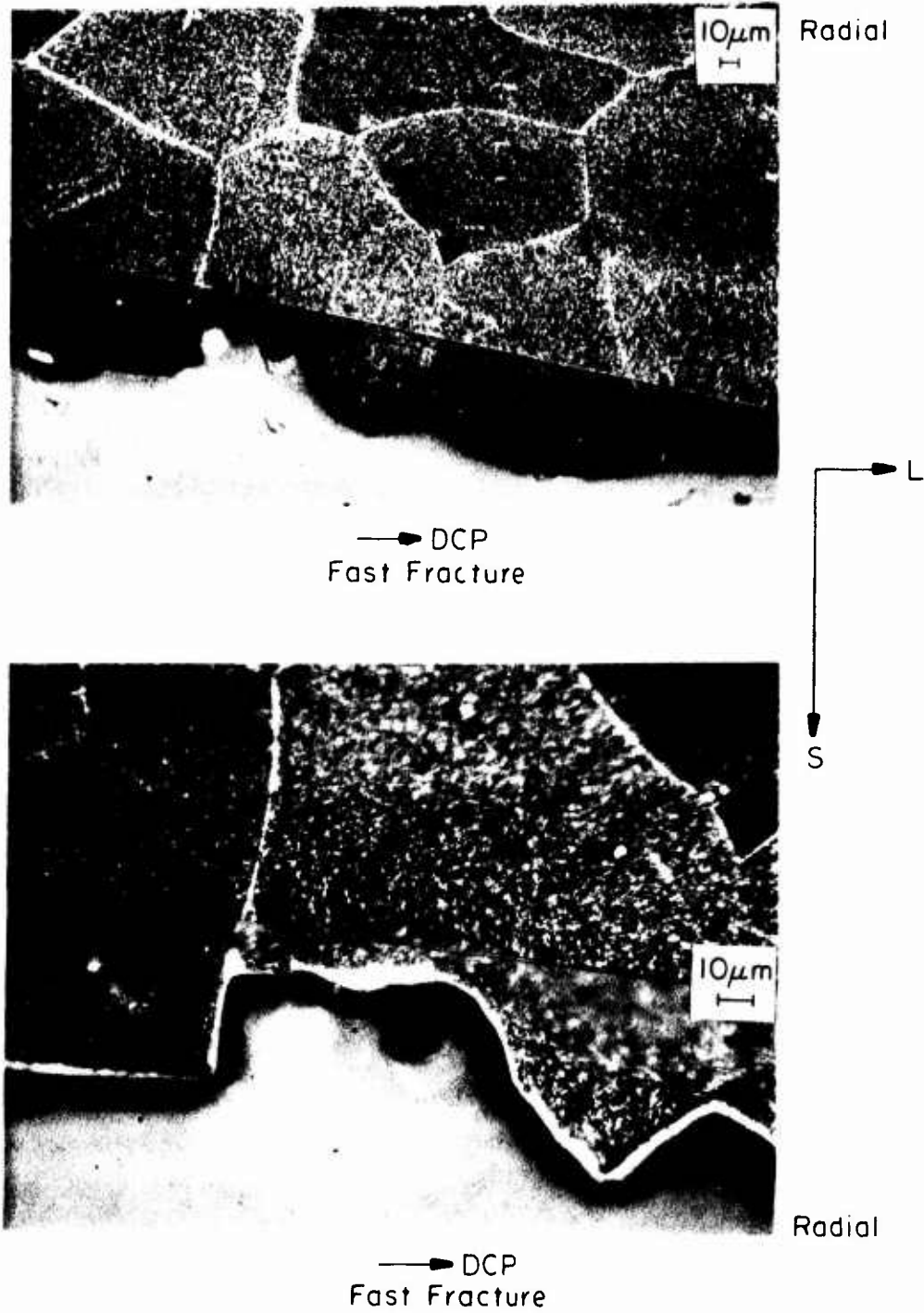

Figure 131. Alloy 334, sample 4MSL8. Crack path (top) X250, (bottom) X500. Mixed mode transgranular/intergranular crack propagation.

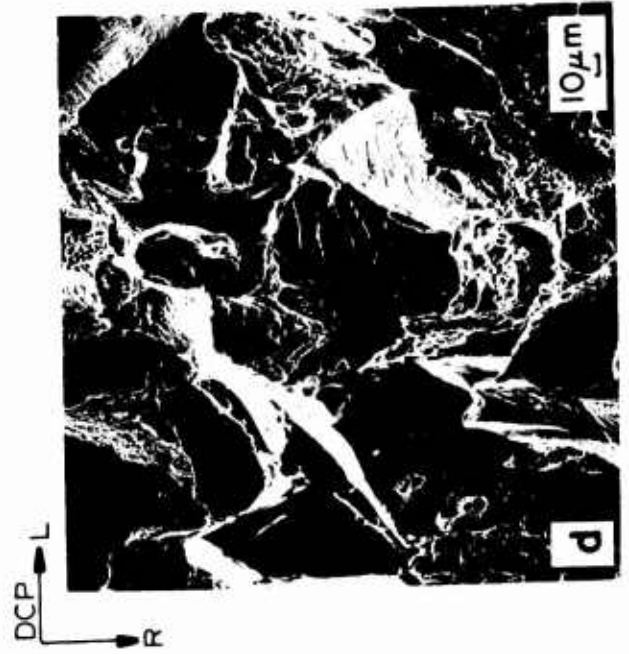
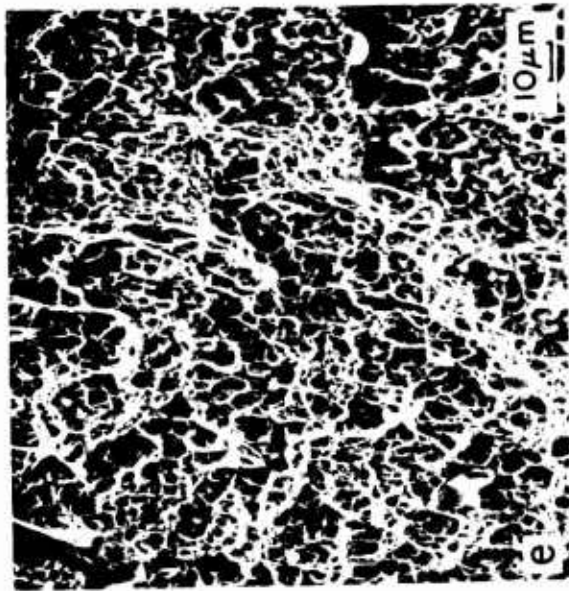
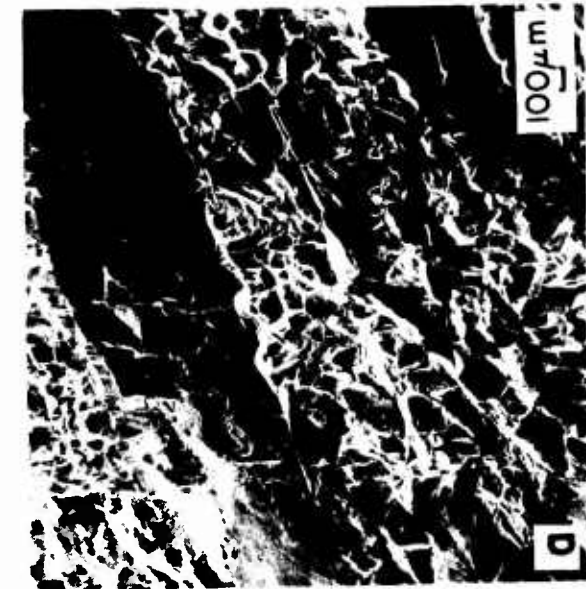

Figure 132. Alloy 334, sample 4MSL8. SEM of fracture surface (a) X30, (b) X300-precrack/fast fracture transition, (c) X1000-fast fracture close to transition, (d) X250, (e) X500-fast fracture

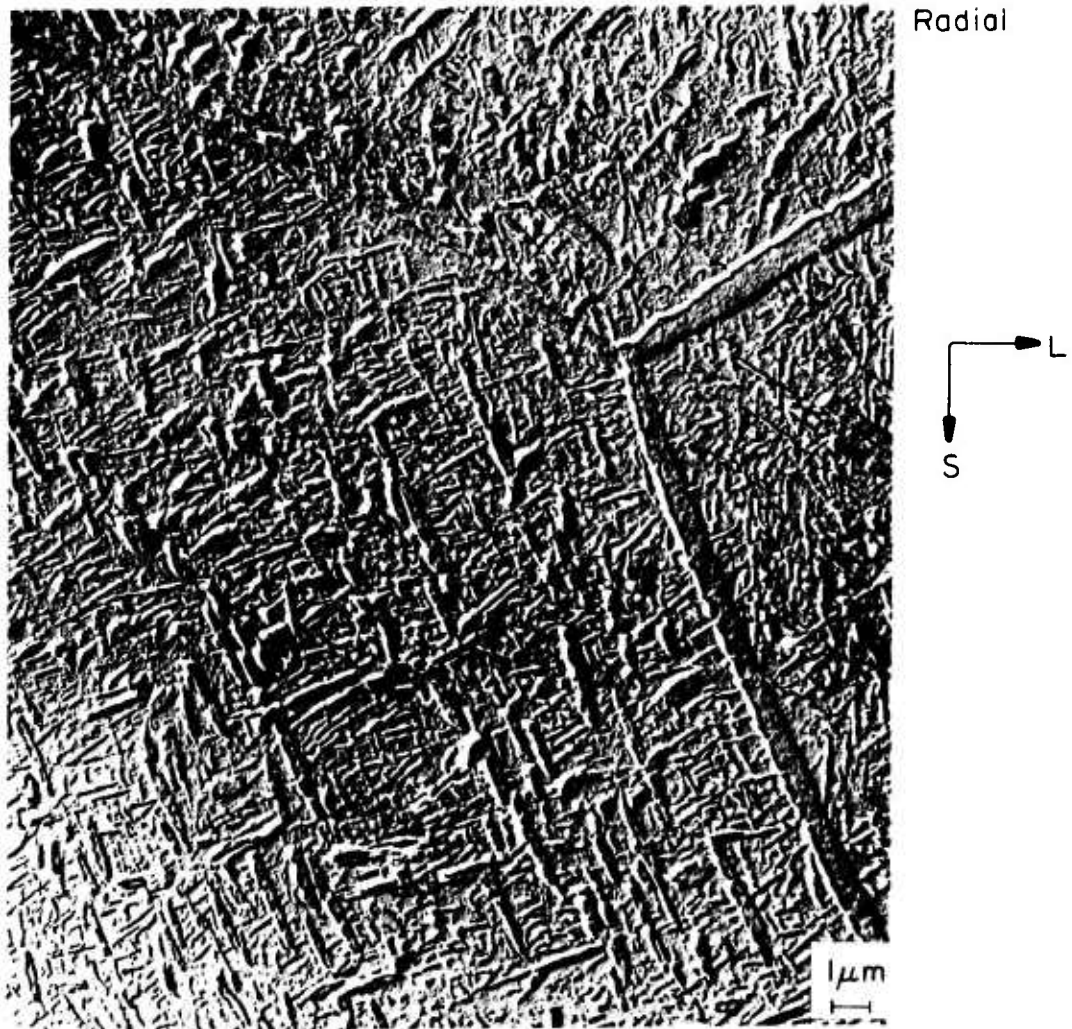

Figure 133 . Alloy 334, sample 4MSL8, surface replica X5200. Note continuous grain boundary alpha.

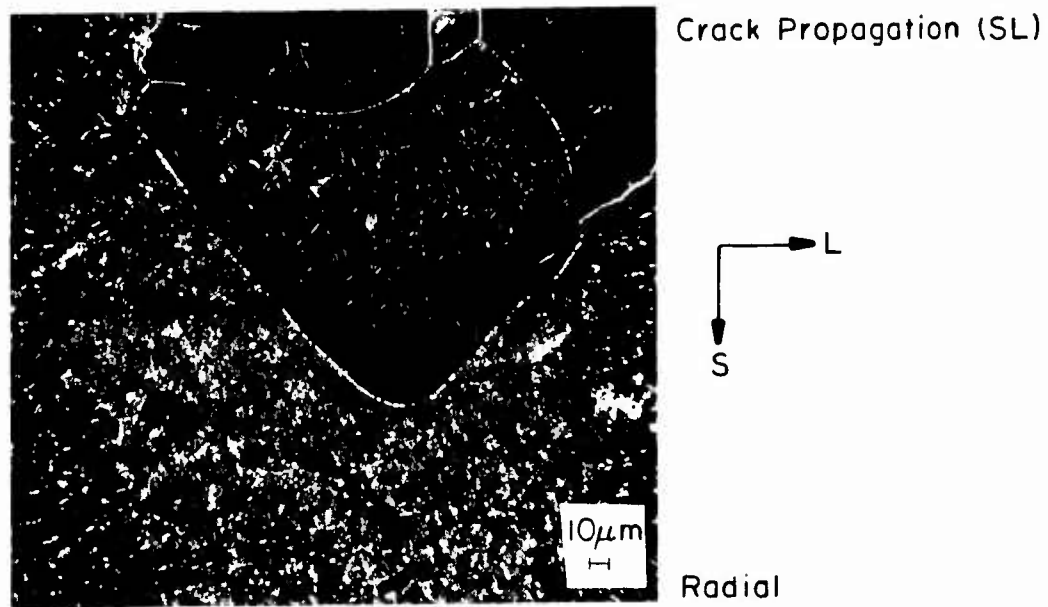
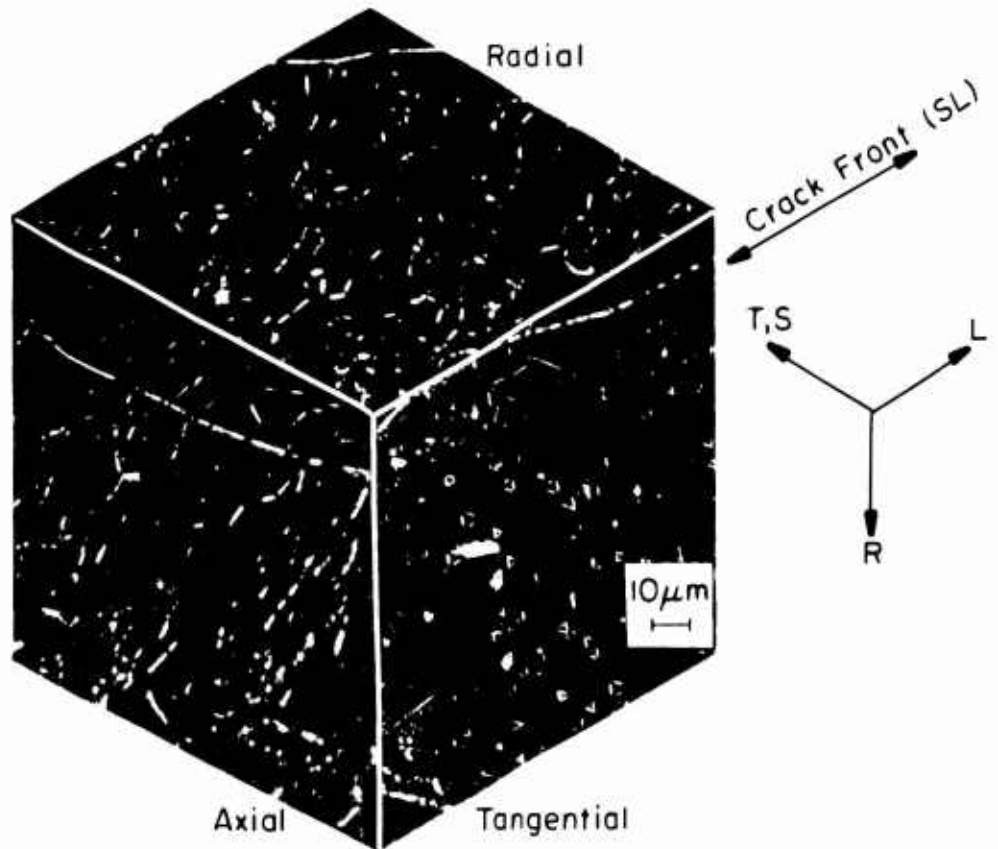
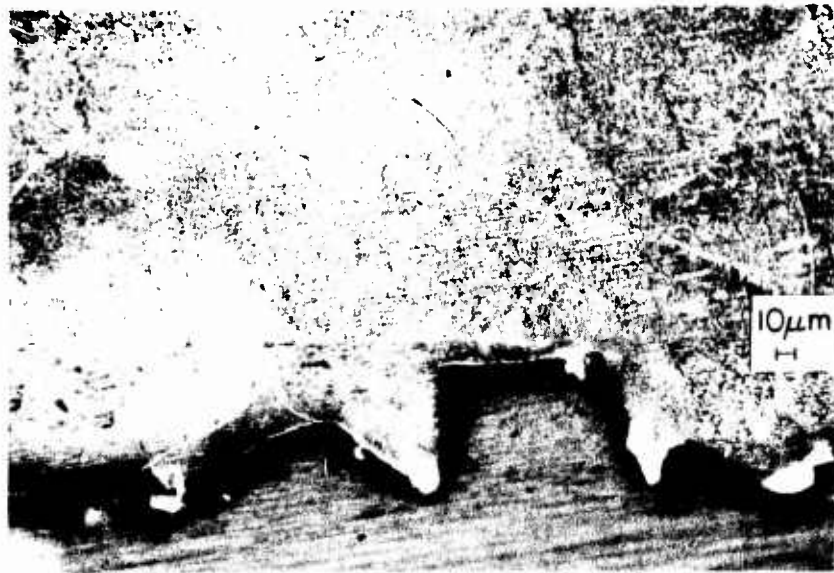

Figure 134. Alloy 227(7Mo-4Cr-2.5Al). Six inch slice, sample 7MSL4 (Table LIV). Recrystallize annealed 1575F- $\frac{1}{2}$ hr Wq, solution annealed 1475F-2 hr WQ, aged 1025F-8 hr. Isometric X500, radial face X250.

YS(ksi):	180 (L)	RA(%):	5 (L)	K_Q (ksi/in):	57 (LR)
	188 (T)		6 (T)		41 (SL)



Radial

—▶ DCP
Fast Fracture



—▶ DCP
Fast Fracture

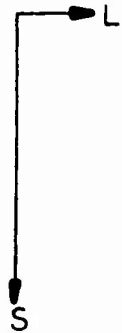
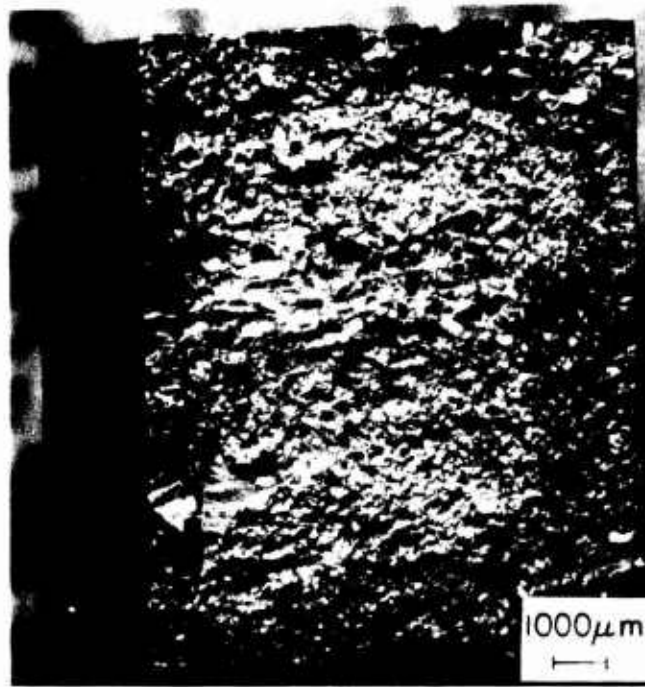
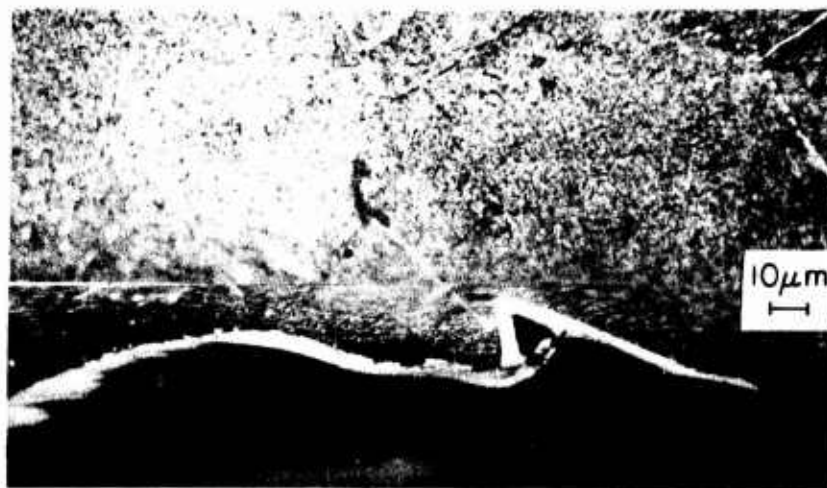
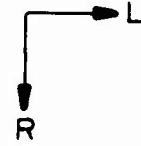

Figure 135 . Alloy 227, sample 7MSL4. Crack path (top) X250, (bottom) X500. Mixed mode transgranular/intergranular crack propagation.



Fracture Surface



Radial

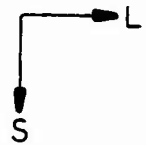

→ DCP
Fatigue Pre-crack

Figure 136 . Alloy 227, sample 7MSL4. Fracture surface X8, crack path X500. Note faceted appearance of fracture surface; essentially flat crack path with some tendency to follow continuous grain boundary alpha.

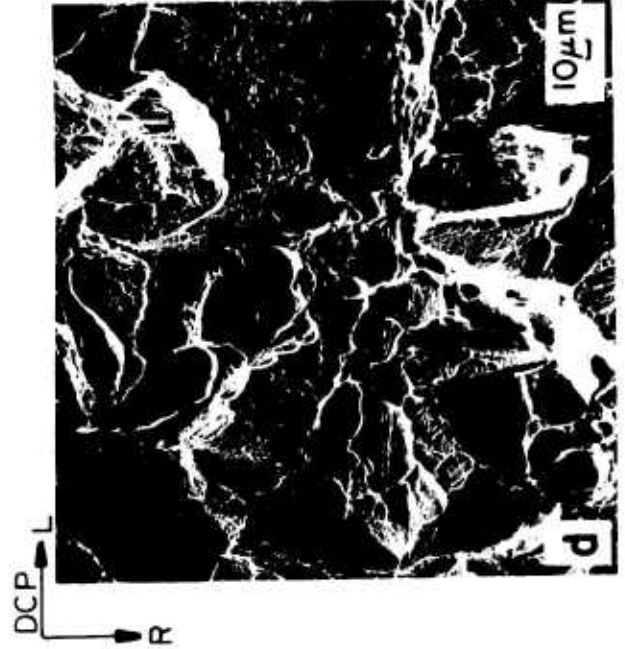
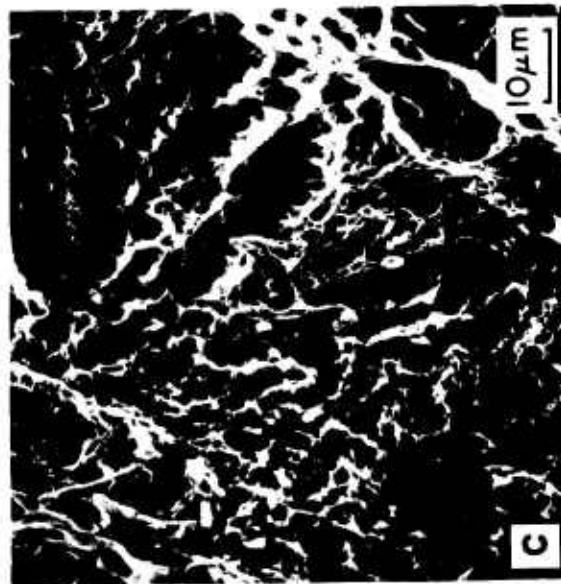
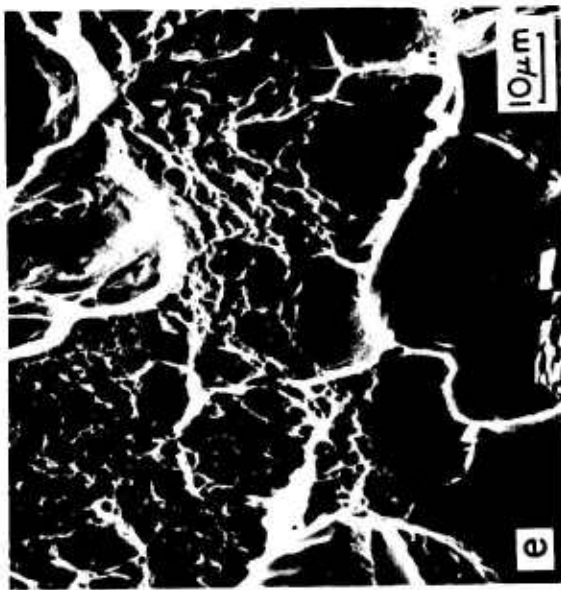

Figure 137. Alloy 227, sample 7MSL4. SEM of fracture surface (a) X25, (b) X250 - precrack/
fast fracture transition, (c) X900 - fast fracture close to transition, (d) X250, (e) X900 -
fast fracture.

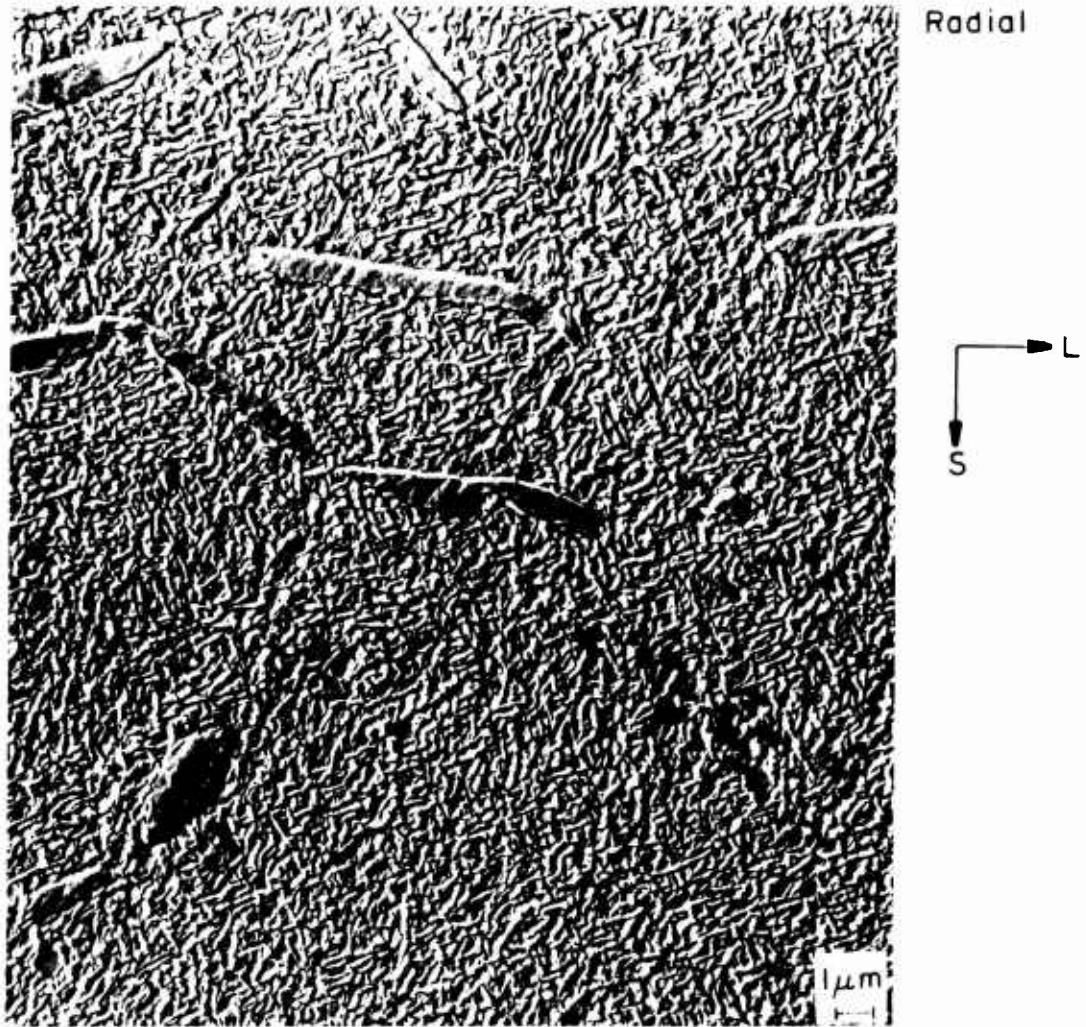

Figure 138. Alloy 227, sample 7MSL4, surface replica X5200.

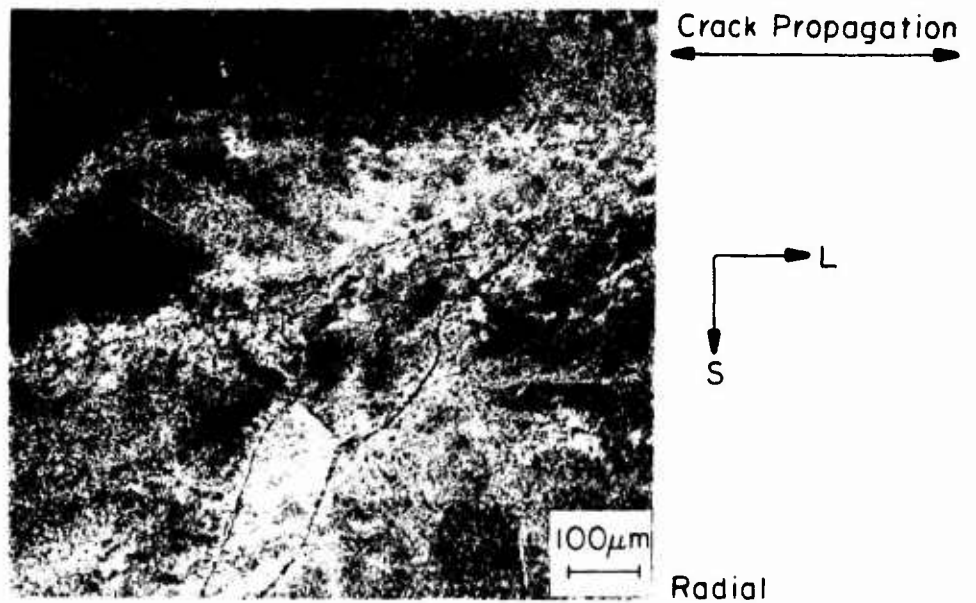
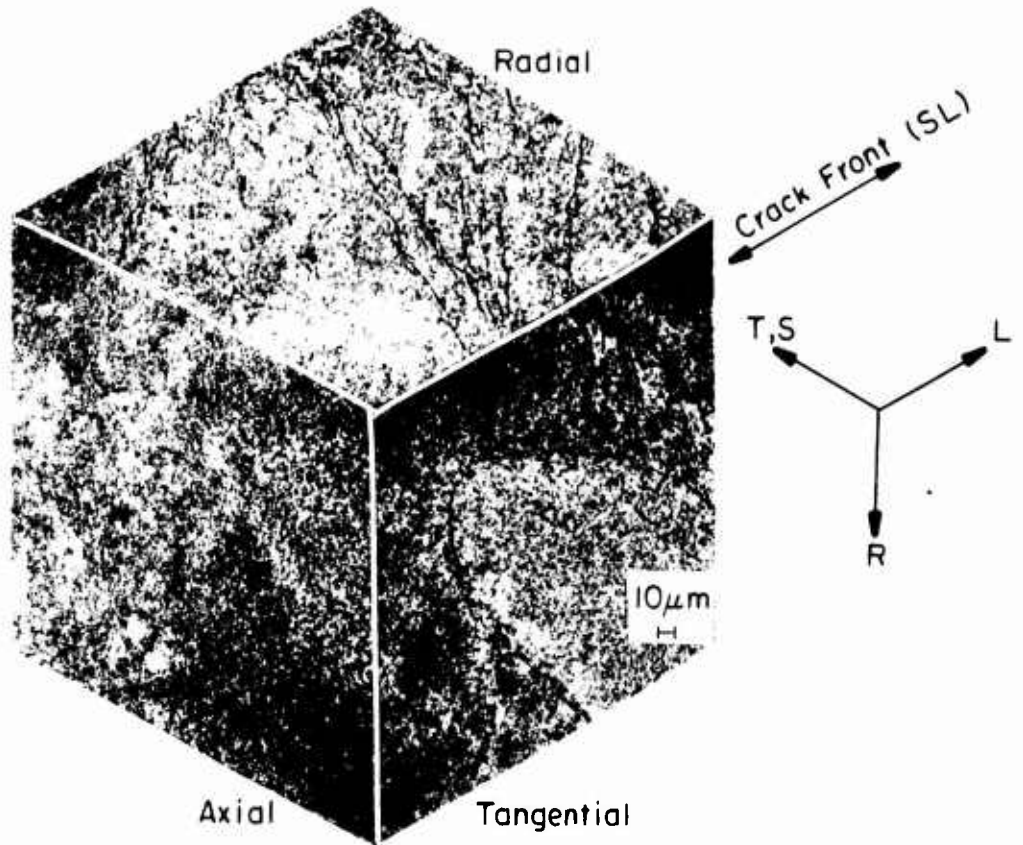
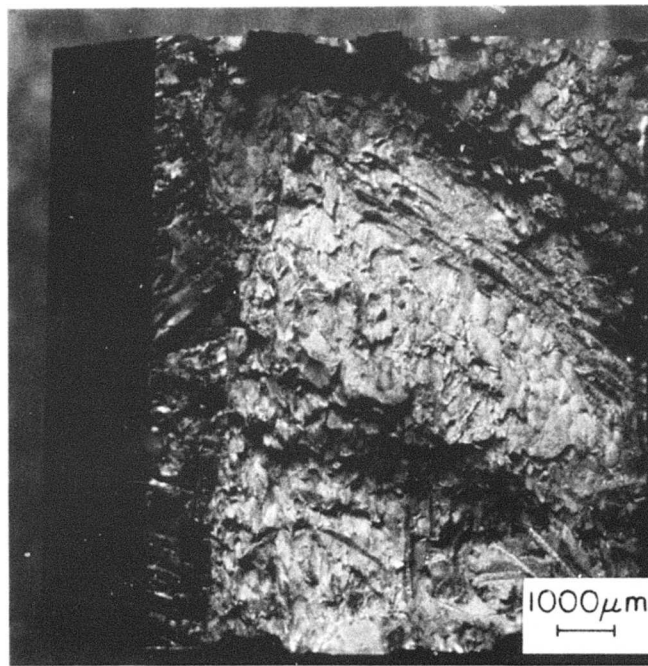
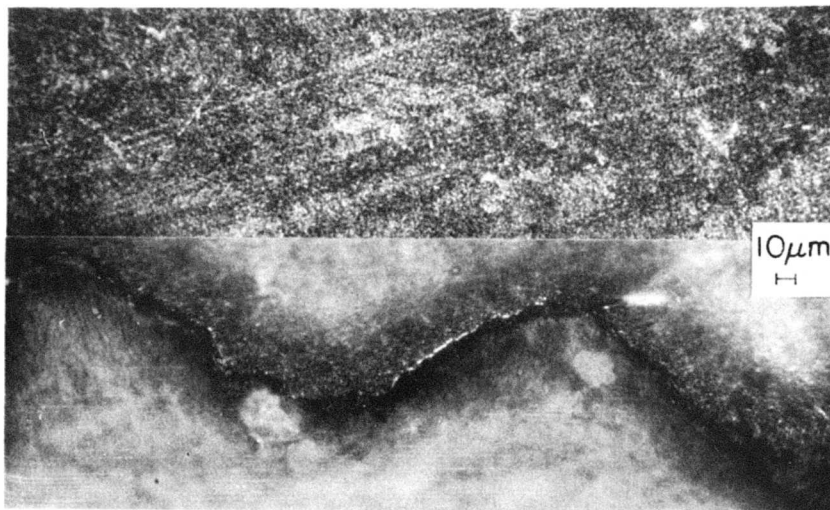
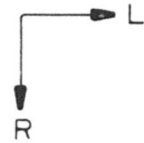

Figure 139 . Alloy 334(10Mo-6Cr-2.5Al). 10.5 inch RCS slice, sample 4SL2 (Table L). Solution annealed 1300F-4 hr WQ, aged 900F-96 hr. Isometric X250, radial face X100.

YS(ksi):	177 (L)	RA(%):	13 (L)	K (ksi/in):	99 (LR)
	182 (T)		9 (T)		60 (SL)



Fracture Surface



Radial

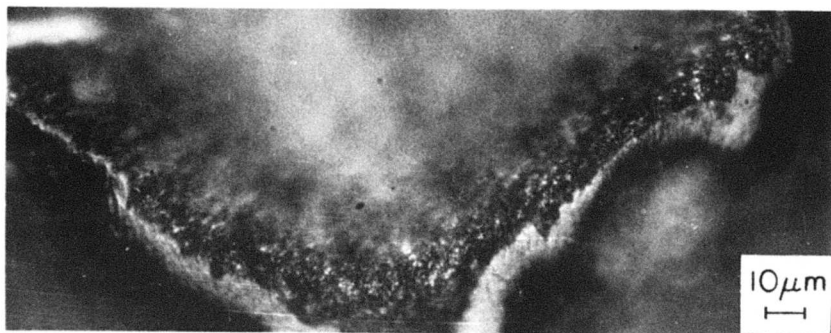

Radial

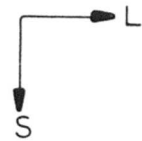
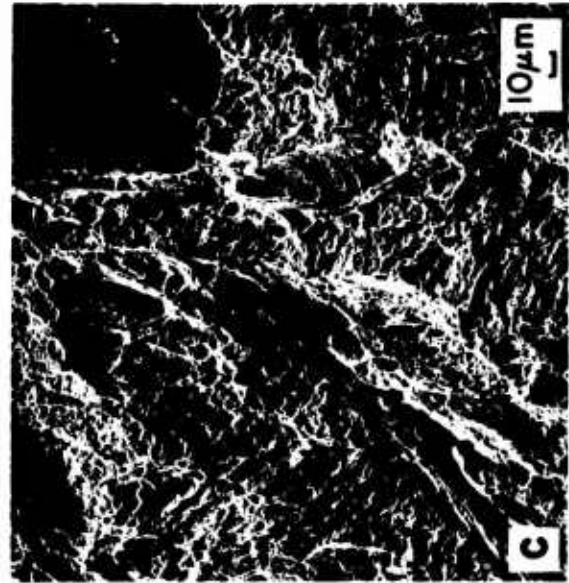

Figure 140. Alloy 334, sample 4SL2. Fracture surface X8, crack path (top) X250, (bottom) X500.

DCP → L
→ R



Figure 141. Alloy 334, sample 4SL2. SEM of fracture surface (a) X30, (b) X200 - precrack/fast fracture transition, (c) X300 - fast fracture.



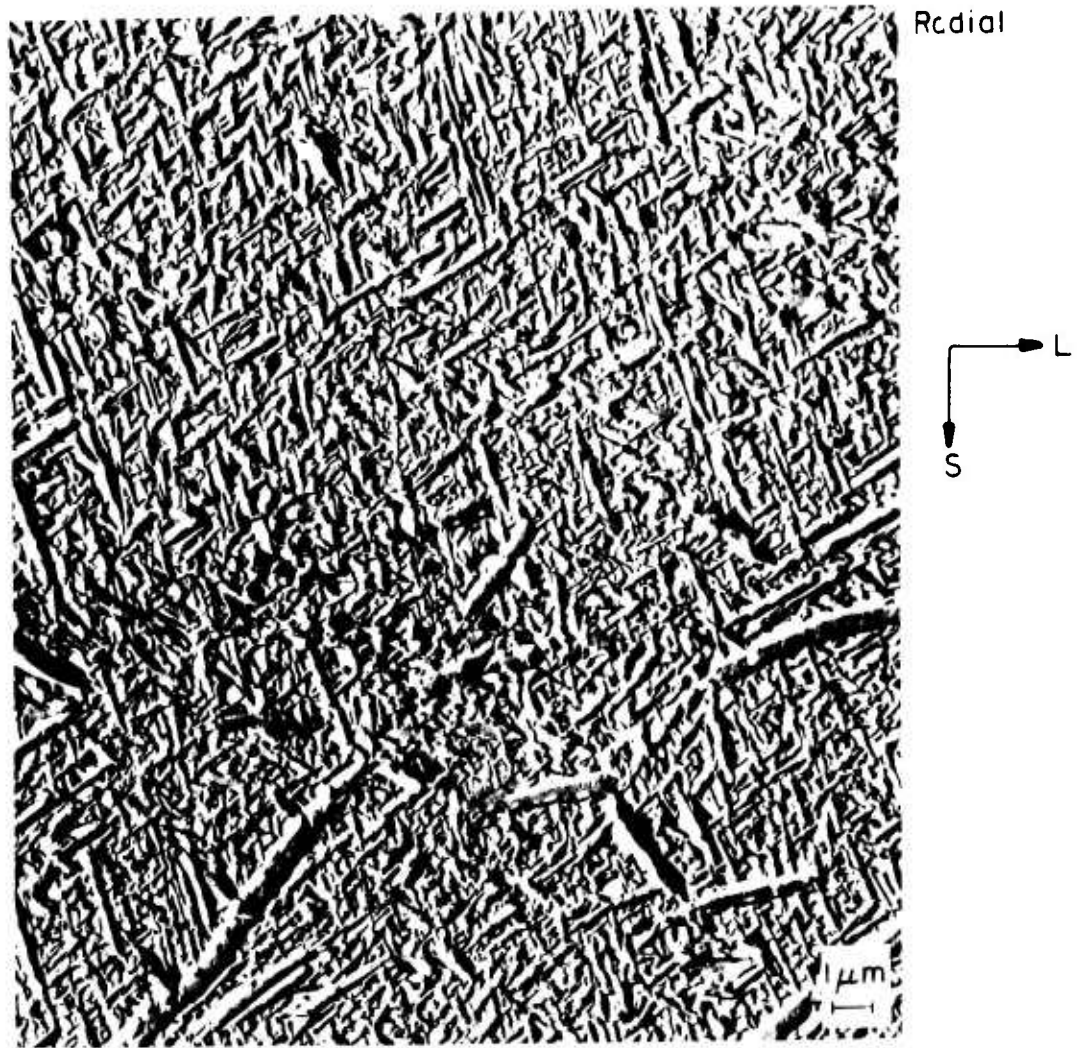

Figure 142. Alloy 334, sample 4SL2. Surface replica X5200.

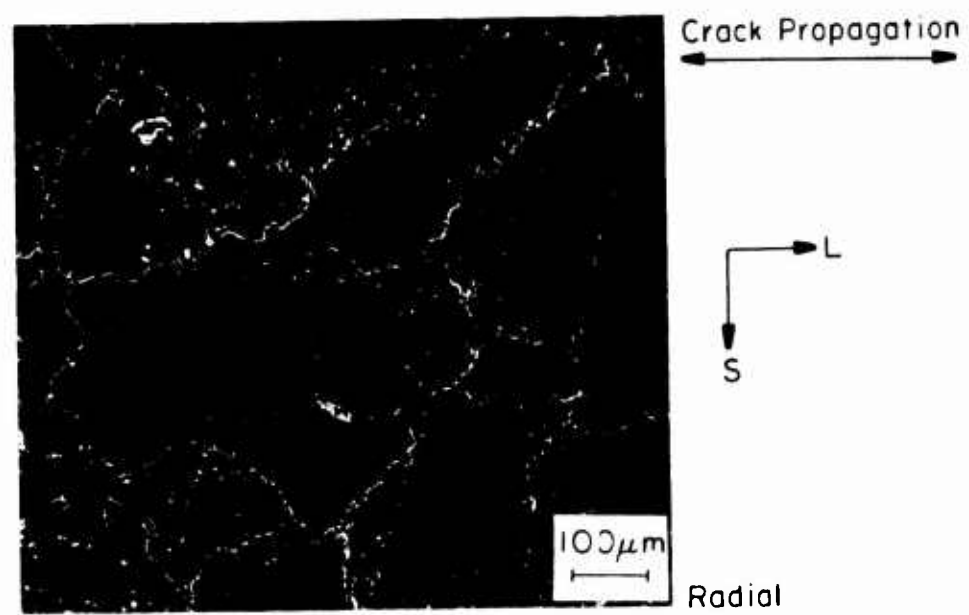
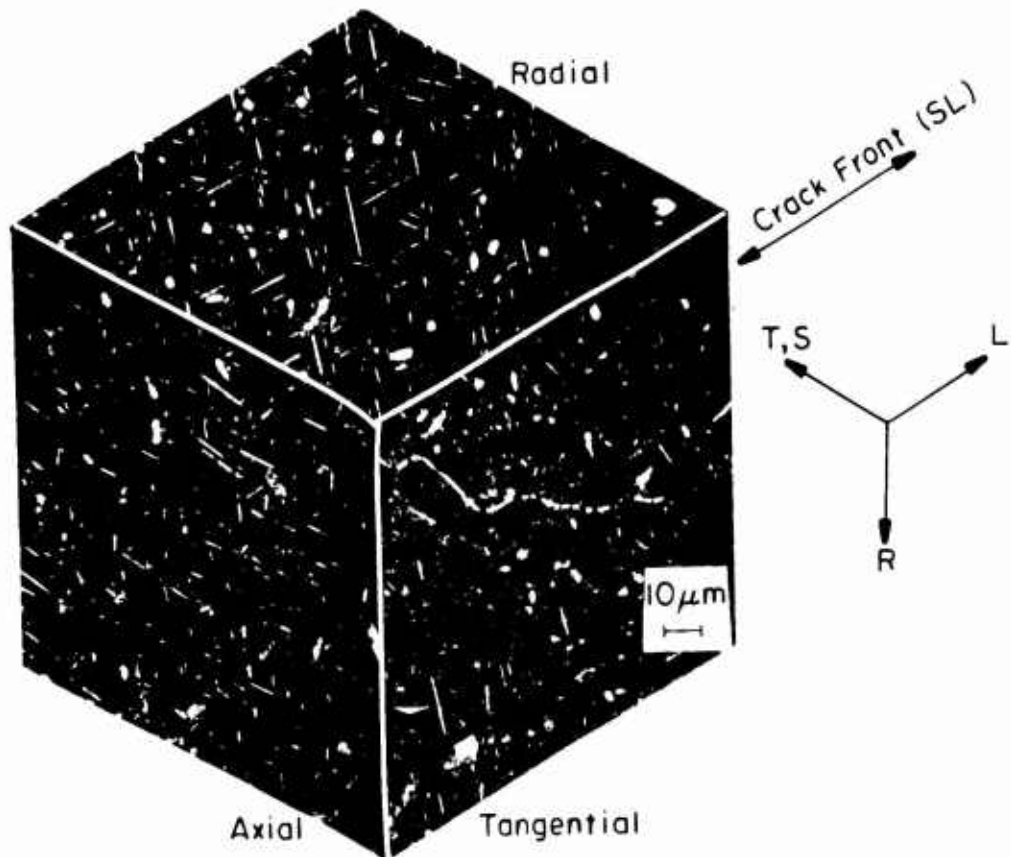
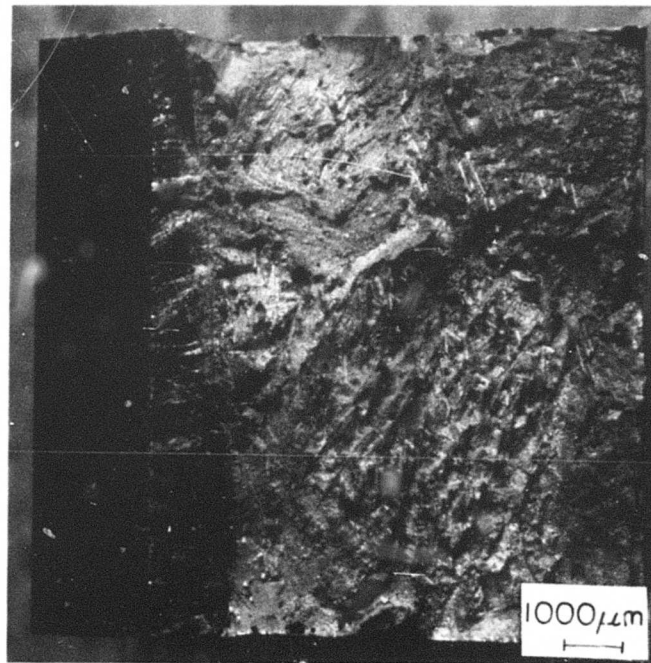

Figure 143. Alloy 227(7Mo-4Cr-2.5Al). 10.5 inch RCS slice, sample 7SL2 (Table LI). Solution annealed 1475F - 2 hr WQ, aged 1025F - 8 hr. Isometric X500, radial face X100.

YS(ksi):	183 (L)	RA(%):	13 (L)	KQ(ksi/in):	53 (LR)
	184 (T)		10 (T)		57 (SL)



Fracture Surface

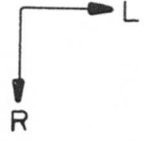

Figure 144 . Alloy 227, sample 7SL2. Fracture surface X8.

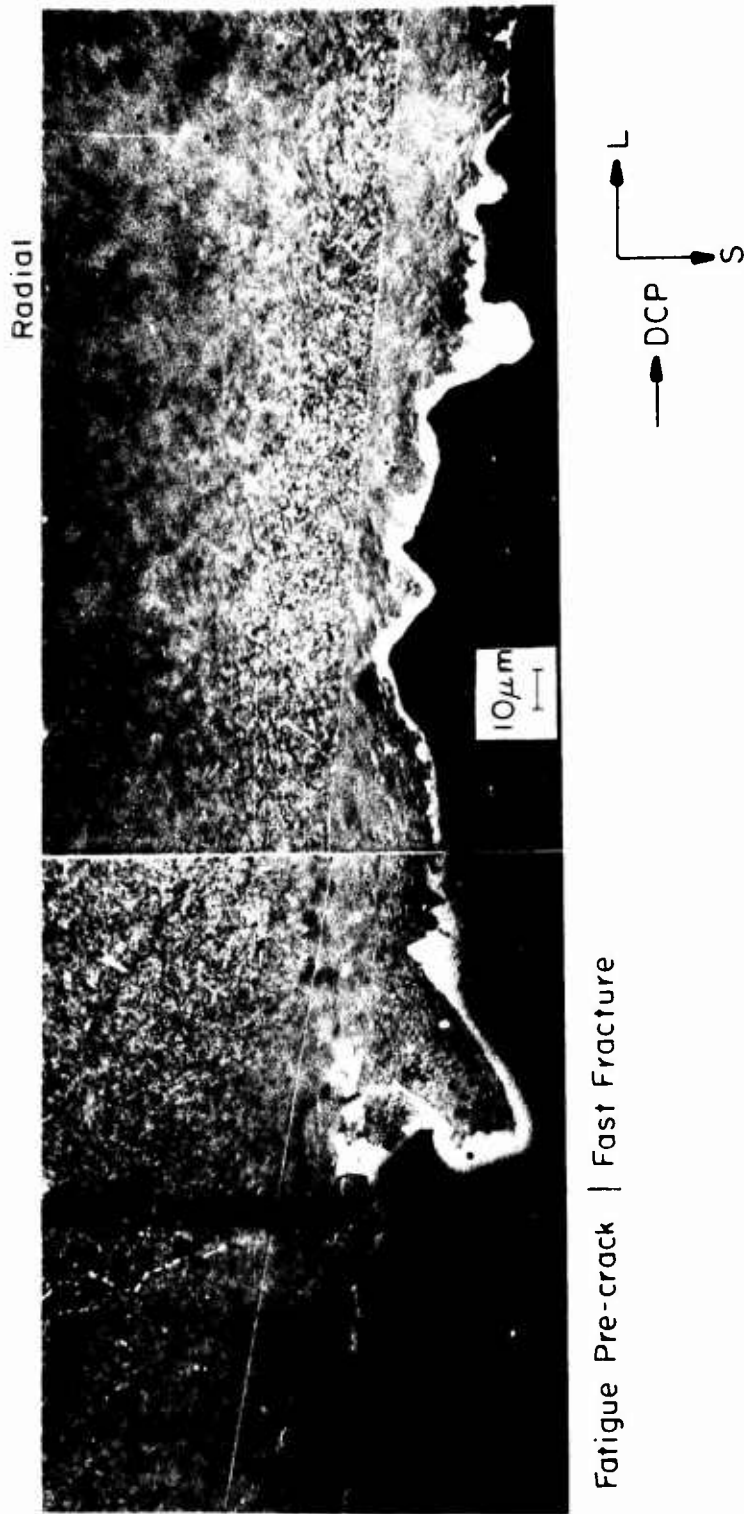

Figure 145. Alloy 227, sample 7SL2, X500.

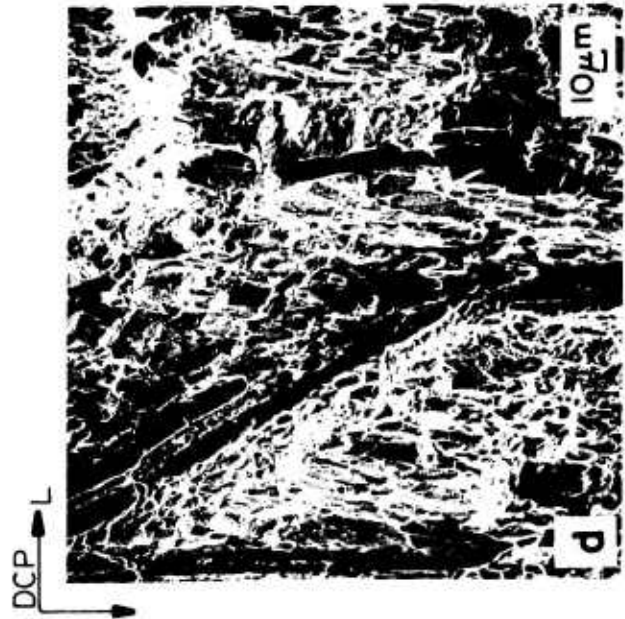

Figure 146. Alloy 227, sample 7SL2. SEM of fracture surface (a) X30, (b) X250 - precrack/fast fracture transition, (c) X1000 - fast fracture close to transition, (d) X250, (e) X1000 - fast fracture.



Figure 147 . Alloy 227, sample 7SL2, surface replica X5200.

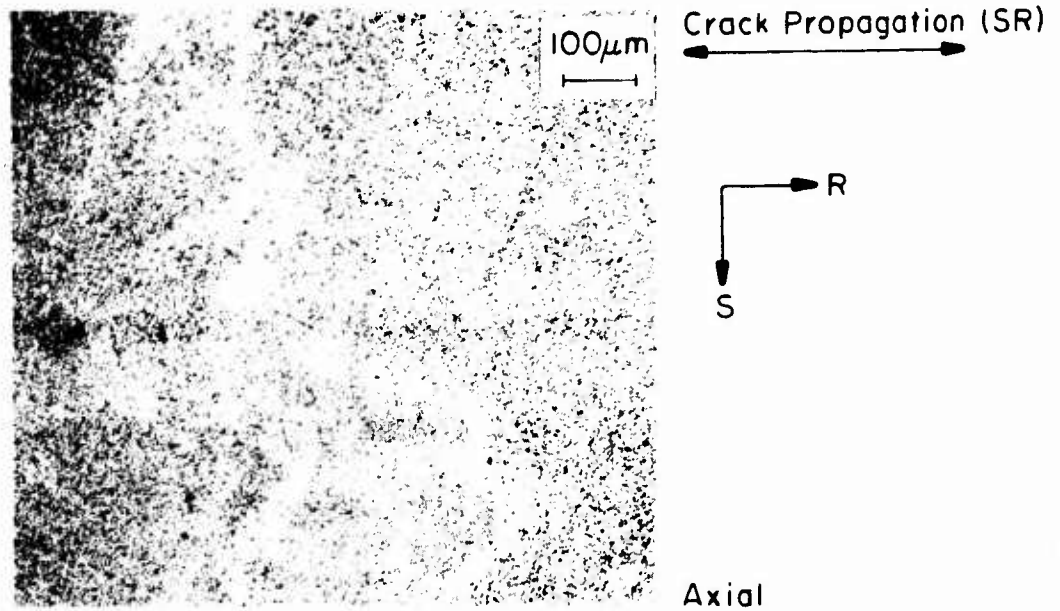
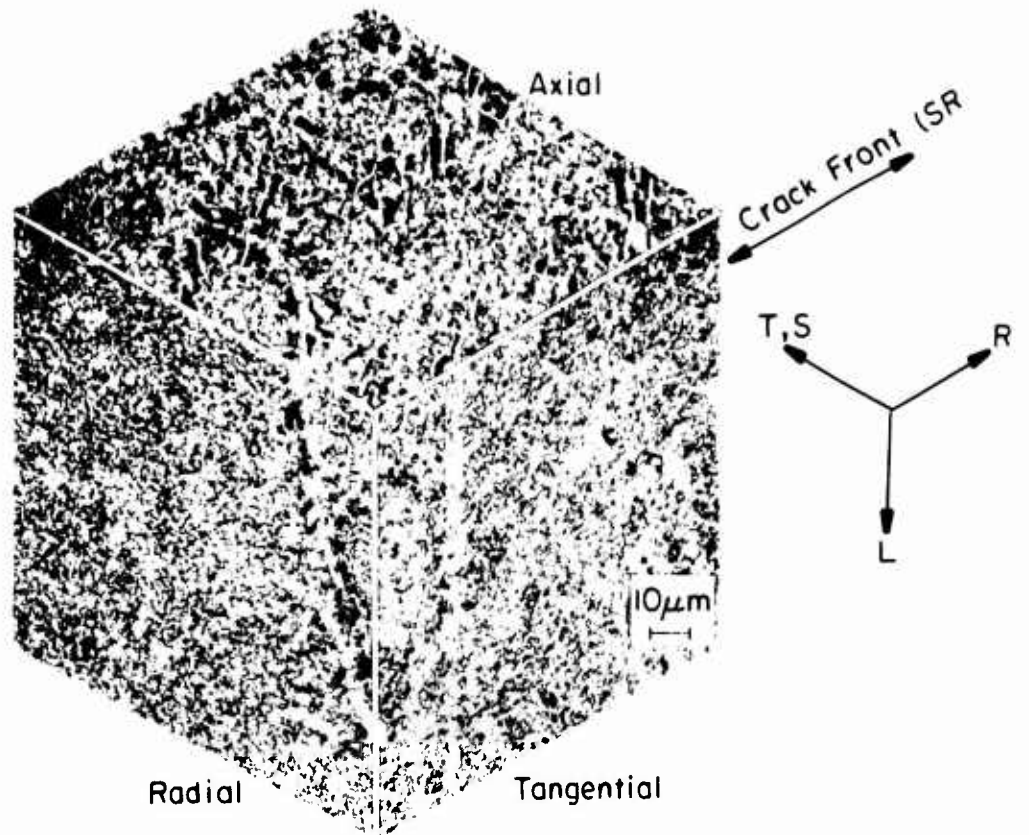
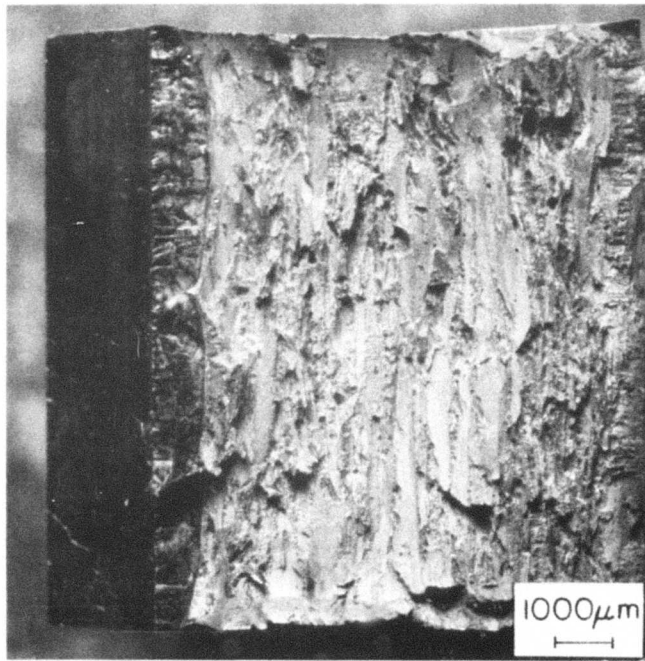
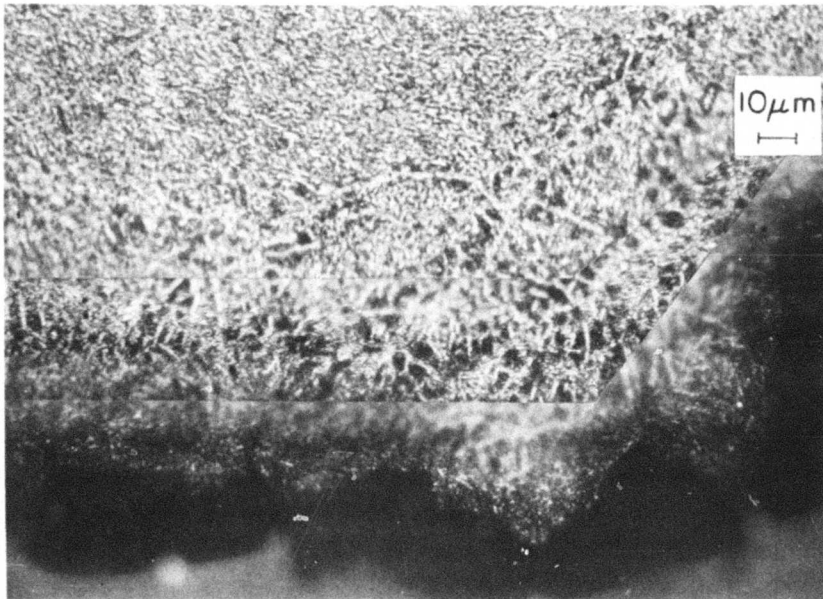
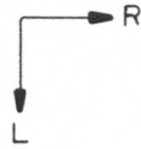

Figure 148 . Alloy 334(10Mo-6Cr-2.5Al). Six inch billet slice, sample 4SR12 (Table LX). Solution annealed 1350F - 4 hr WQ plus 1200F - 4 hr WQ, aged 900F - 96 hr. Isometric X500, axial face X100.

YS(ksi):	147 (L)	RA(%):	39 (L)	K _Q (ksi/in):	158 (LR)
	149 (T)		23 (T)		83 (SR)



Fracture Surface



Axial

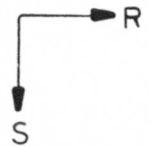

→ DCP

Figure 149 . Alloy 334, sample 4SR12. Fracture surface X8, crack path X500.

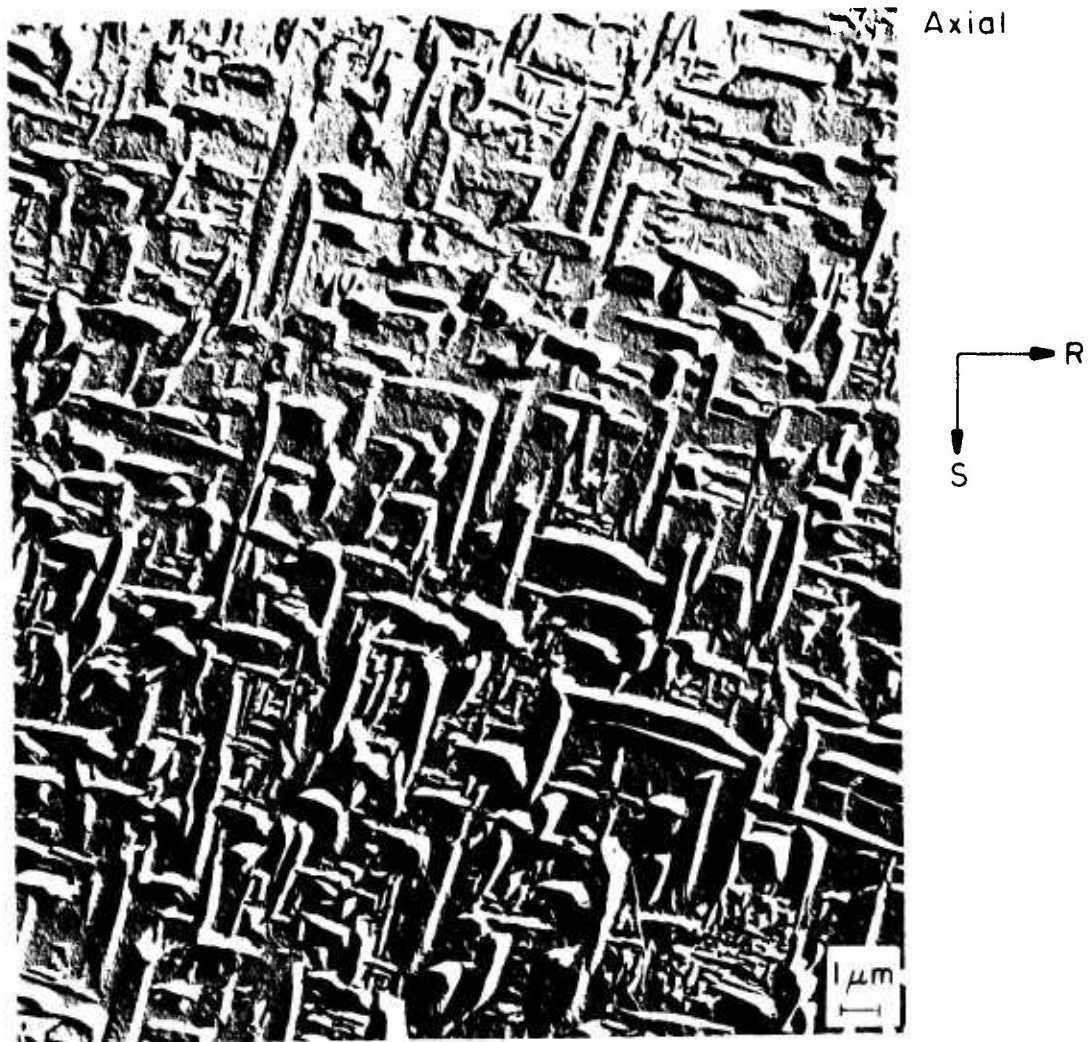

Figure 150 . Alloy 334, sample 4SR12. Surface replica X5200.

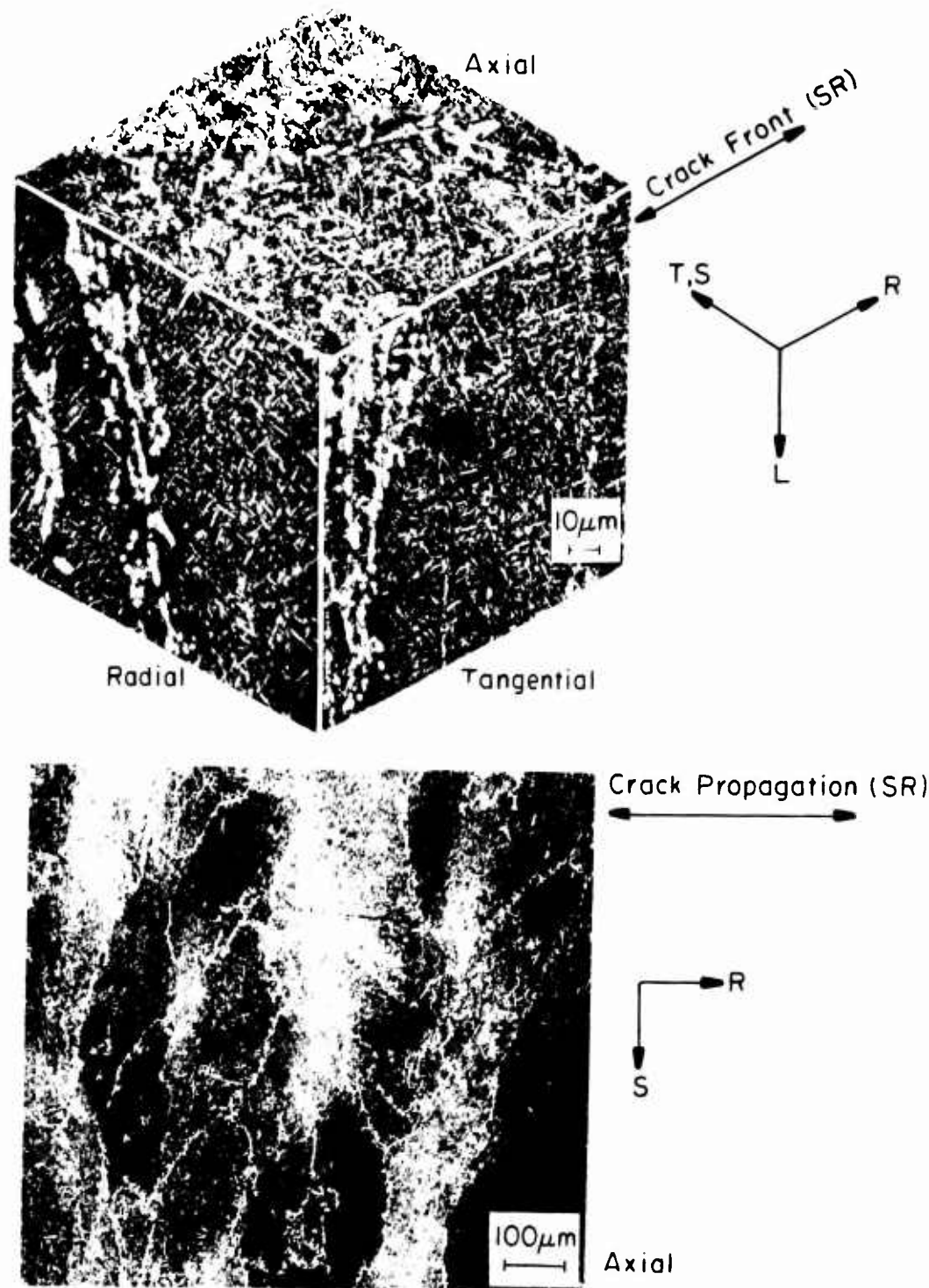
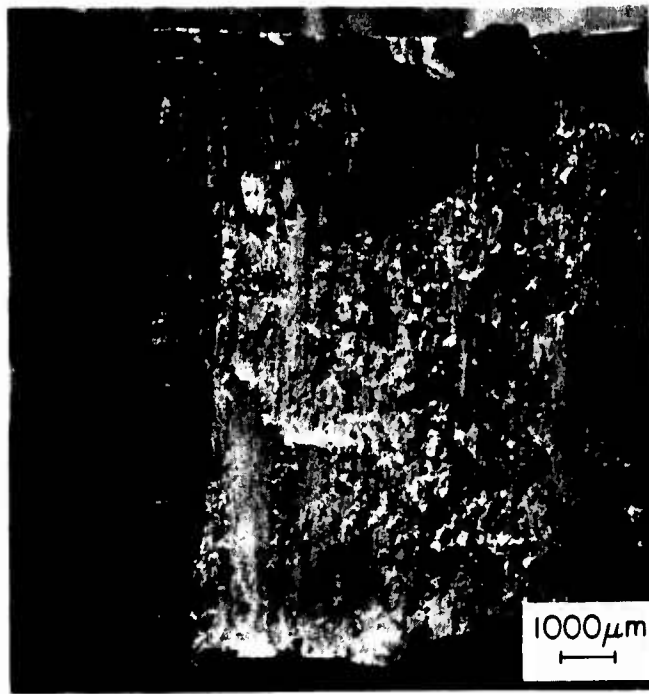
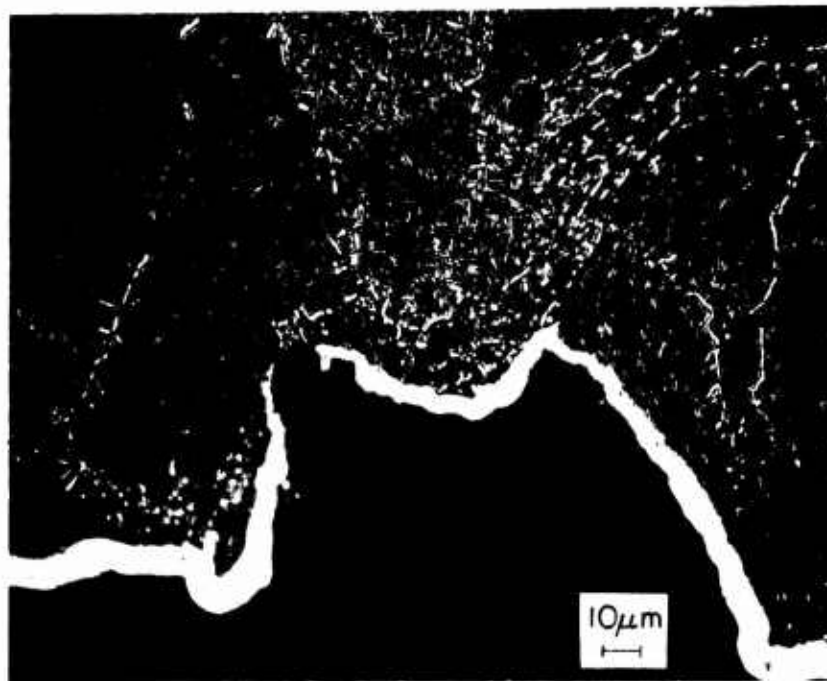

Figure 151. Alloy 227(7Mo-4Cr-2.5Al). Six inch billet slice, sample 7SR22 (Table LXI). Solution annealed 1450F - 2 hr WQ plus 1250F - 4 hr WQ, aged 950F - 8 hr. Isometric X500, axial face X100.

YS(ksi):	146 (L)	RA(%):	58 (L)	K _Q (ksi/in):	179 (LR)
	146 (T)		44 (T)		86 (SR)



Fracture Surface



Axial

Fatigue Pre-crack | Part Fracture
 Transition → DCP

Figure 152. Alloy 227, sample 7SR22. Fracture surface X8, crack path X500.

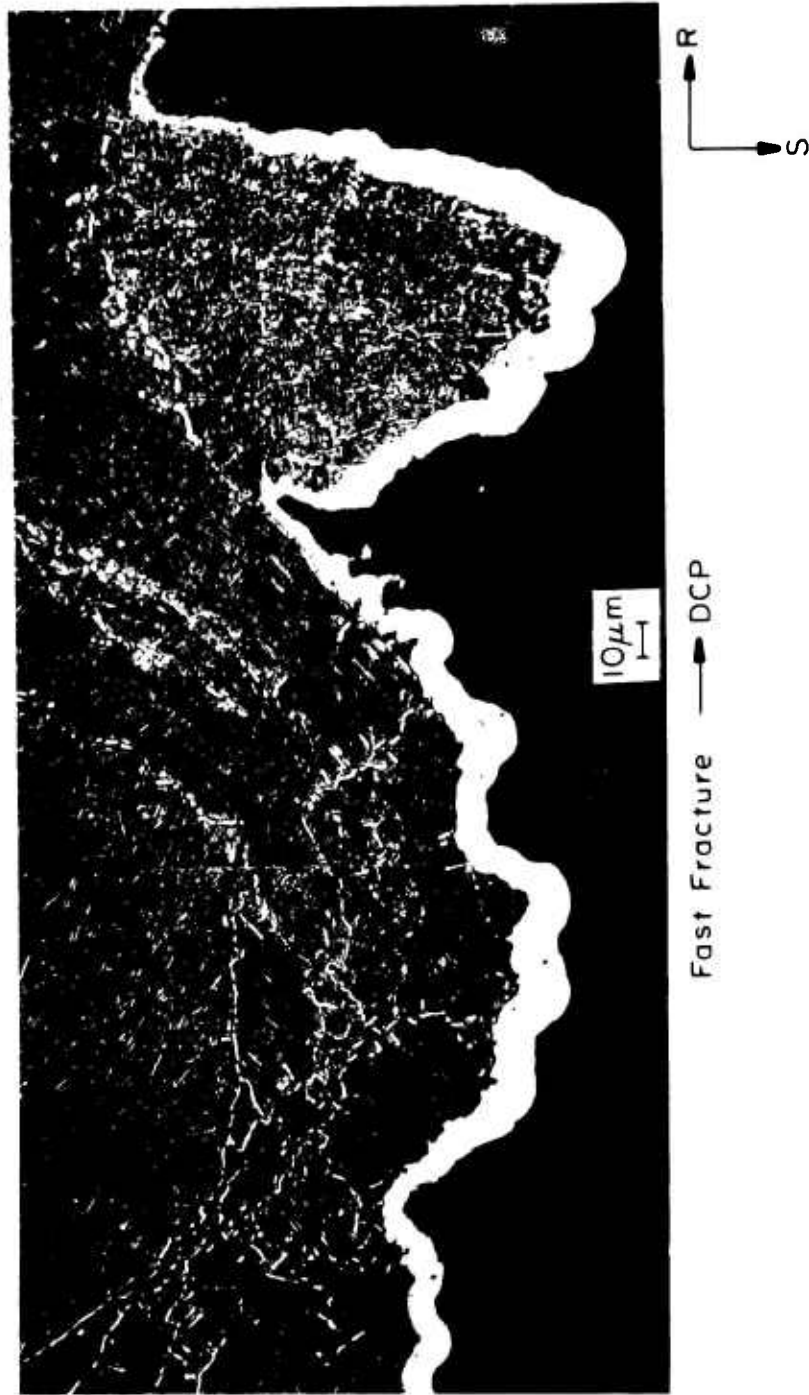

Figure 153. Alloy 227, sample 7SR22. Crack path X500.



Figure 154. Alloy 227, sample 7SR22. Surface replica X5200.

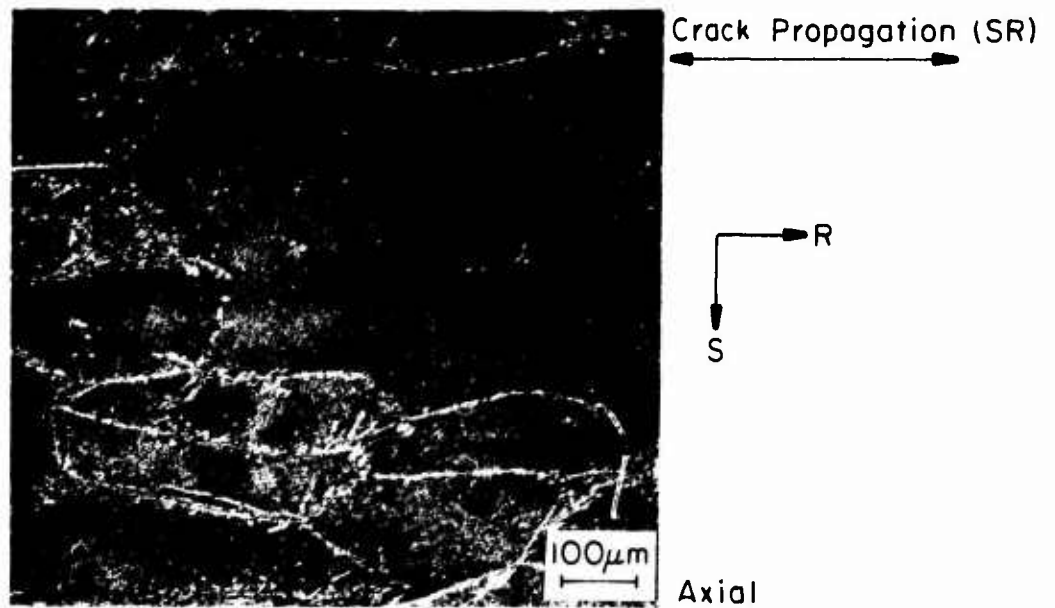
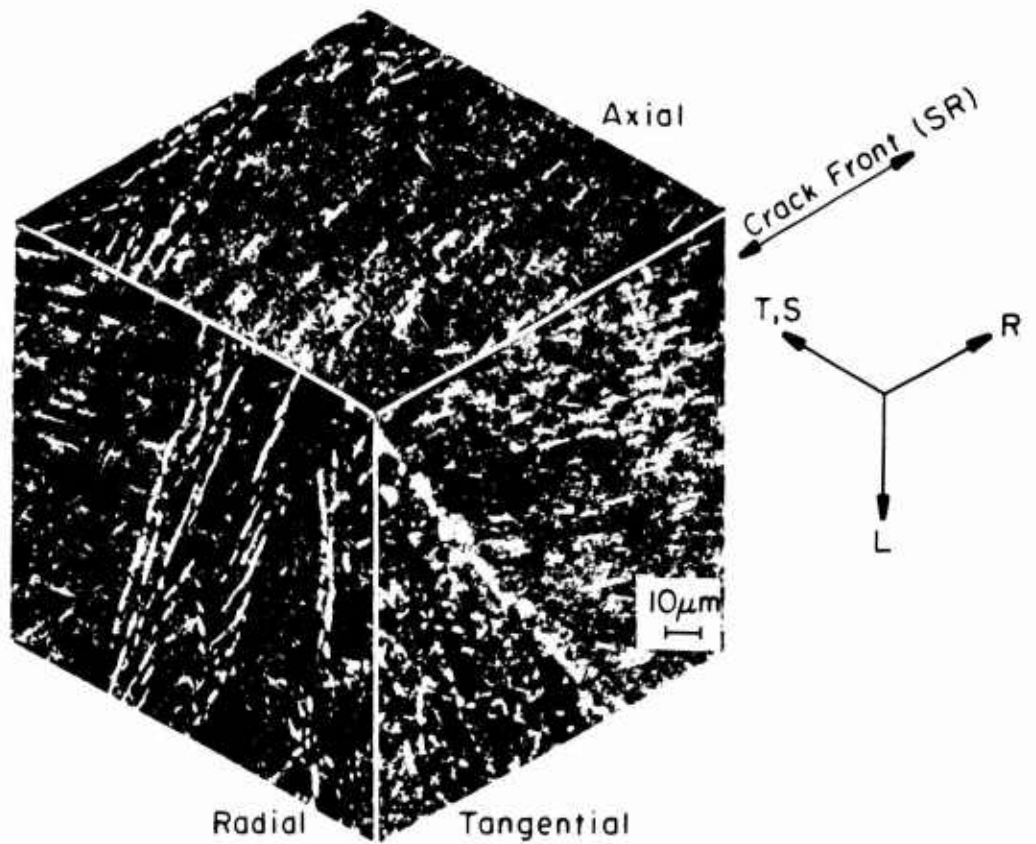
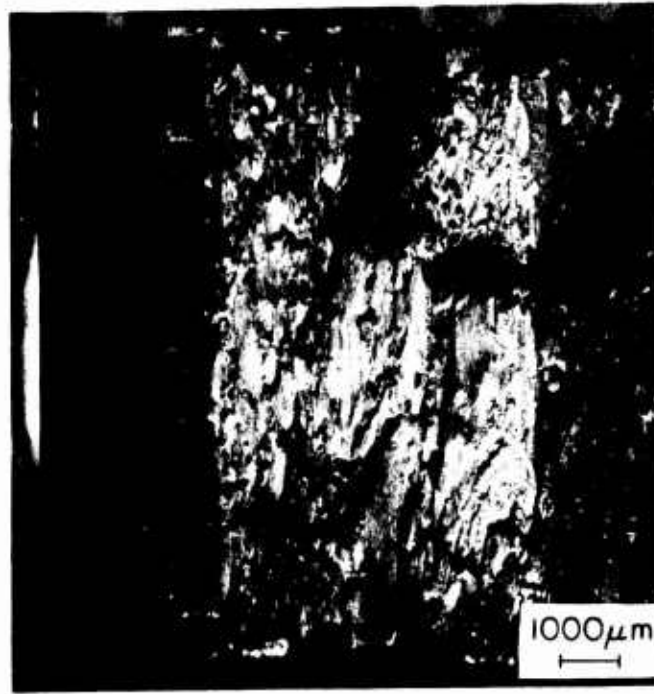
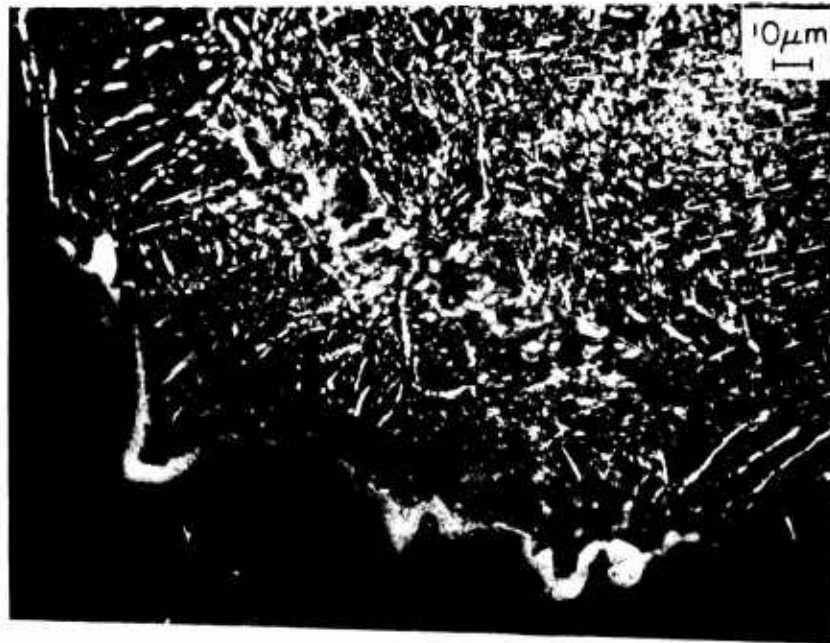
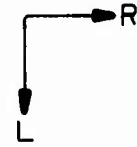

Figure 155. Alloy 334(10Mo-6Cr-2.5Al). Six inch billet slice, sample 4SR16 (Table LVIII). Solution annealed 1250F - 8 hr WQ plus 1375F - 24 hr Wq plus 1325F - 100 hr WQ, aged 950F - 96 hr. Isometric X500, axial face X100.

YS(ksi):	167 (L)	RA(%):	31 (L)	K _Q (ksi/in):	95 (LR)
	170 (T)		6 (T)		60 (SR)



Fracture Surface



Axial

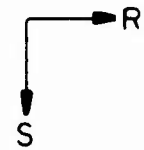

Fast Fracture → DCP

Figure 156 . Alloy 334, sample 4SR16. Fracture surface X8, crack path X500.

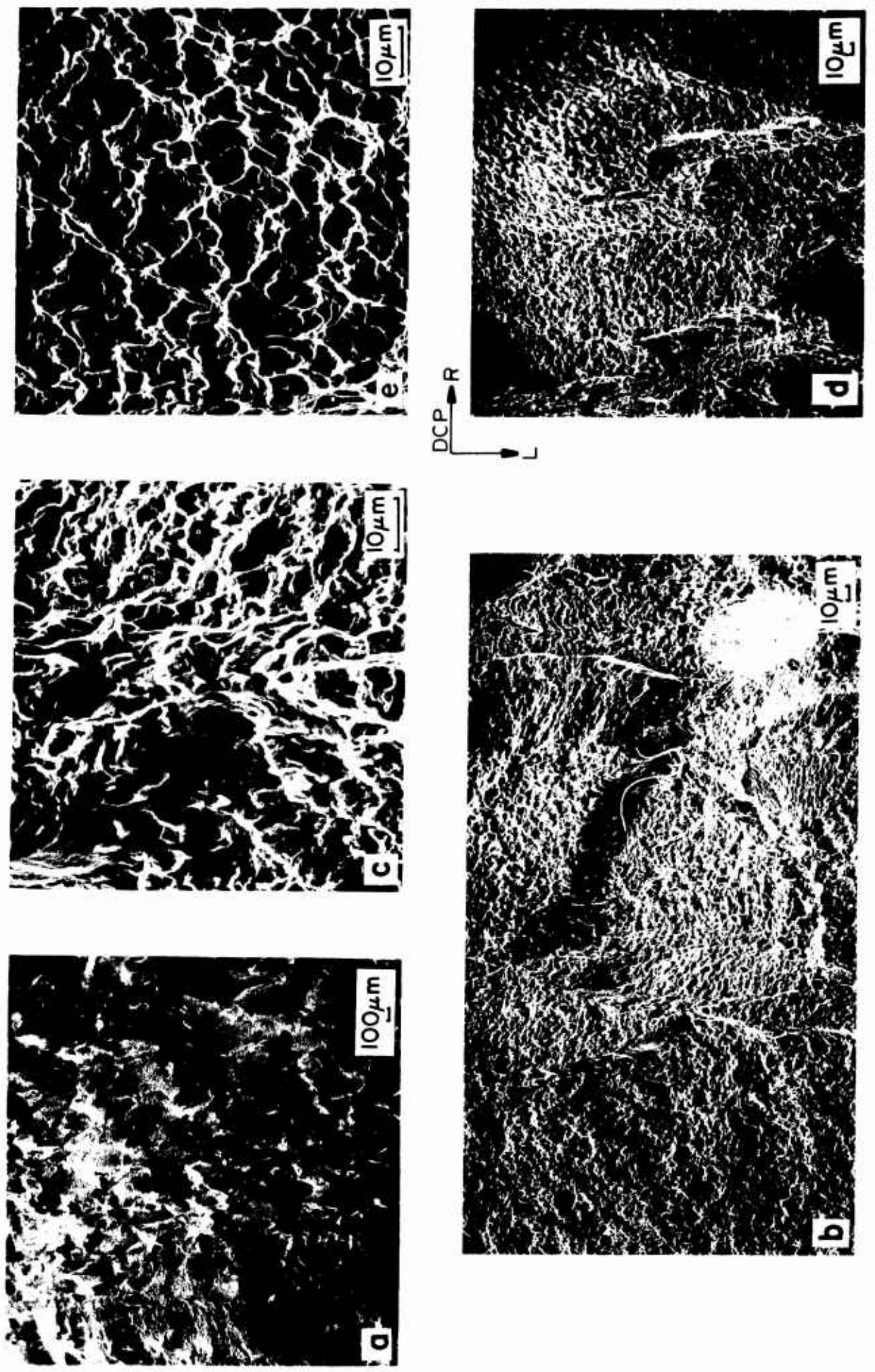

Figure 157. Alloy 334, sample 4SR16. SEM of fracture surface (a) X25, (b) X250 - precrack/fast fracture transition, (c) X250, (d) X500 - fast fracture.

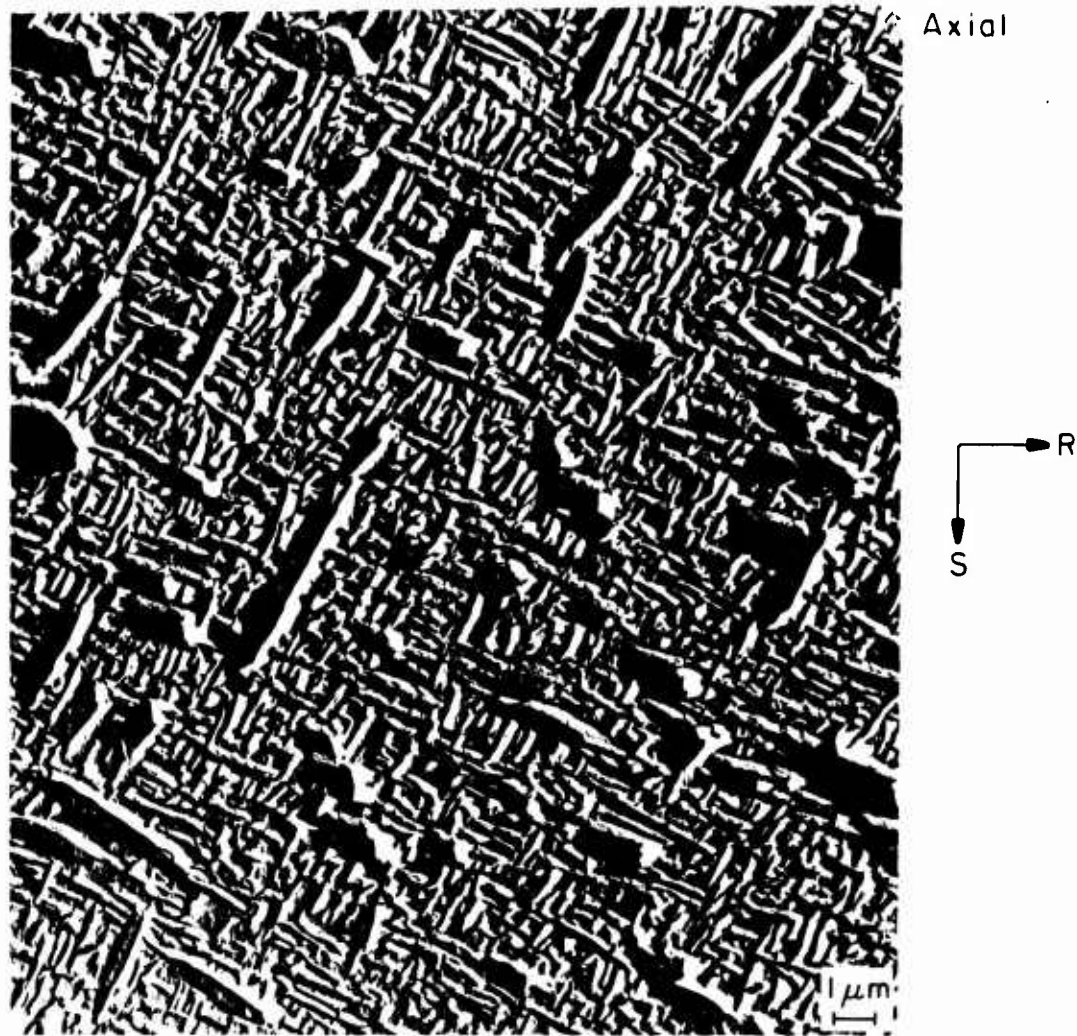

Figure 158. Alloy 334, sample 4SR16. Surface replica X5200.

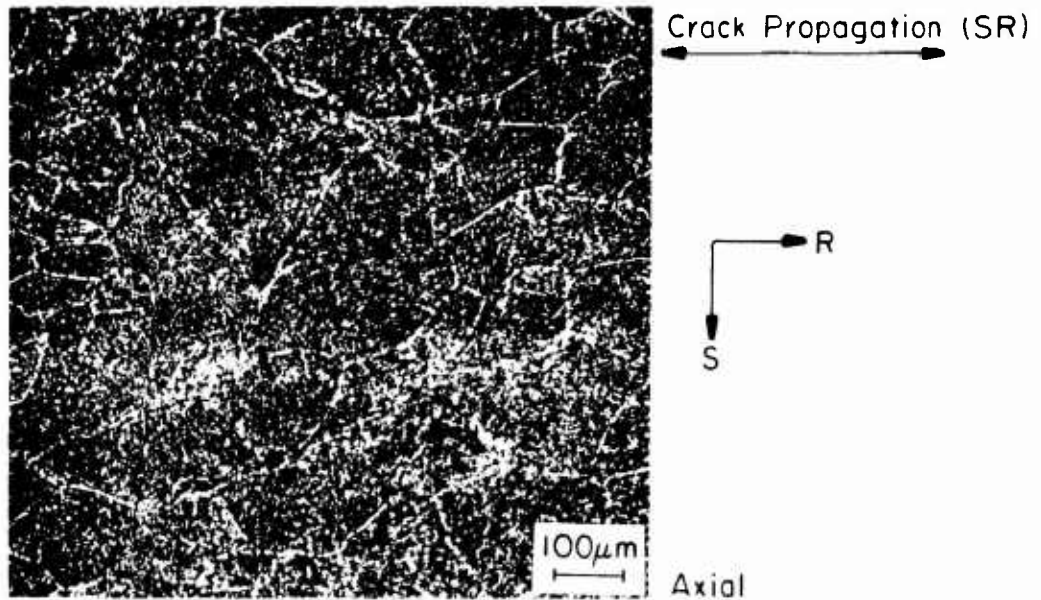
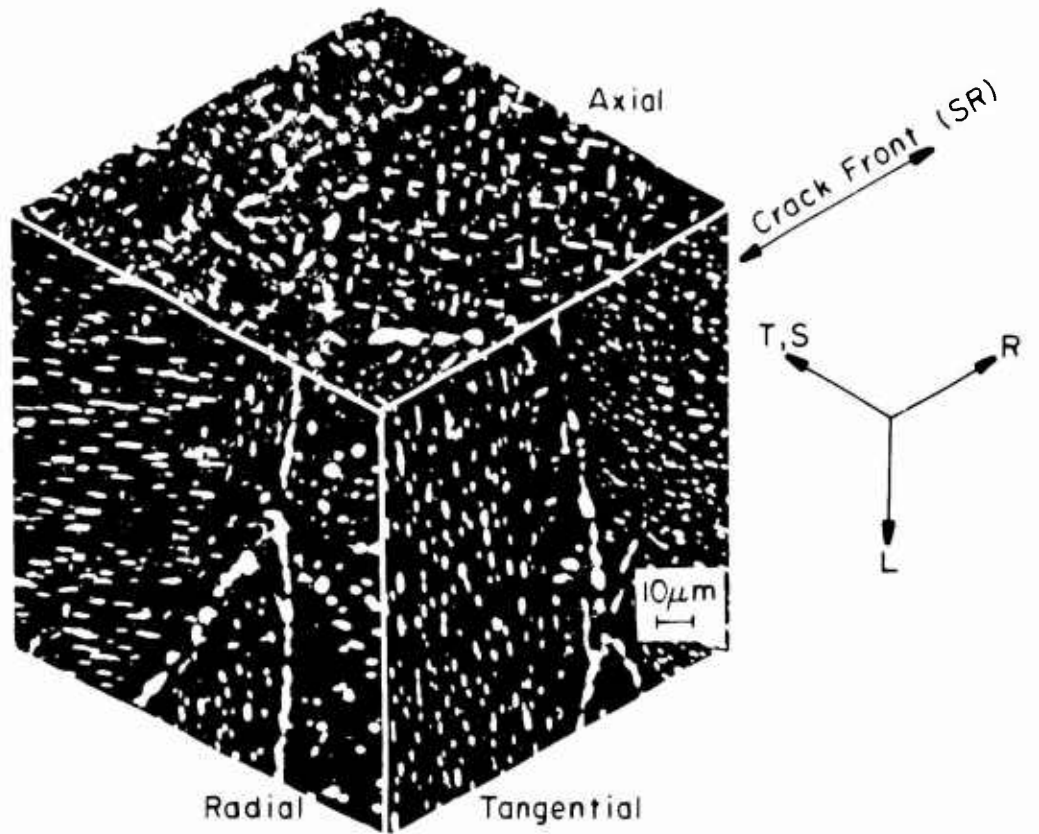
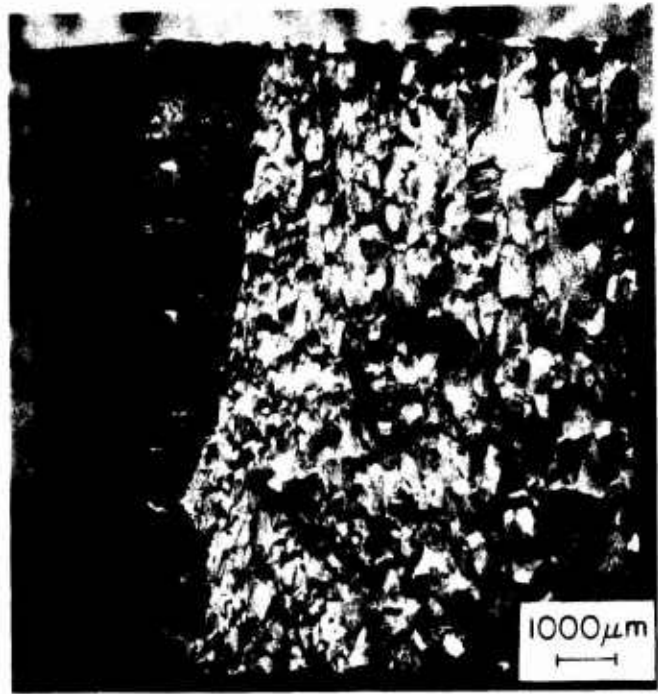
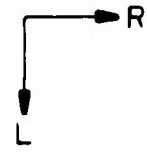

Figure 159. Alloy 227(7Mo-4Cr-2.5Al). Six inch billet slice, sample 7SR20 (Table LIX). Solution annealed 1350F-8 hr WQ plus 1475F - 24 hr WQ plus 1425F - 100 hr WQ, aged 1025F - 8 hr. Isometric X500, axial face X100.

YS(ksi):	--- (L)	RA(%):	-- (L)	K_Q (ksi/in):	-- (LR)
	166 (T)		11 (T)		38 (SR)



Fracture Surface



Axial

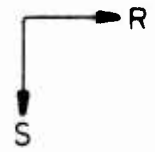

Fast Fracture → DCP

Figure 160 . Alloy 227, sample 7SR20. Fracture surface X8, crack path X250.

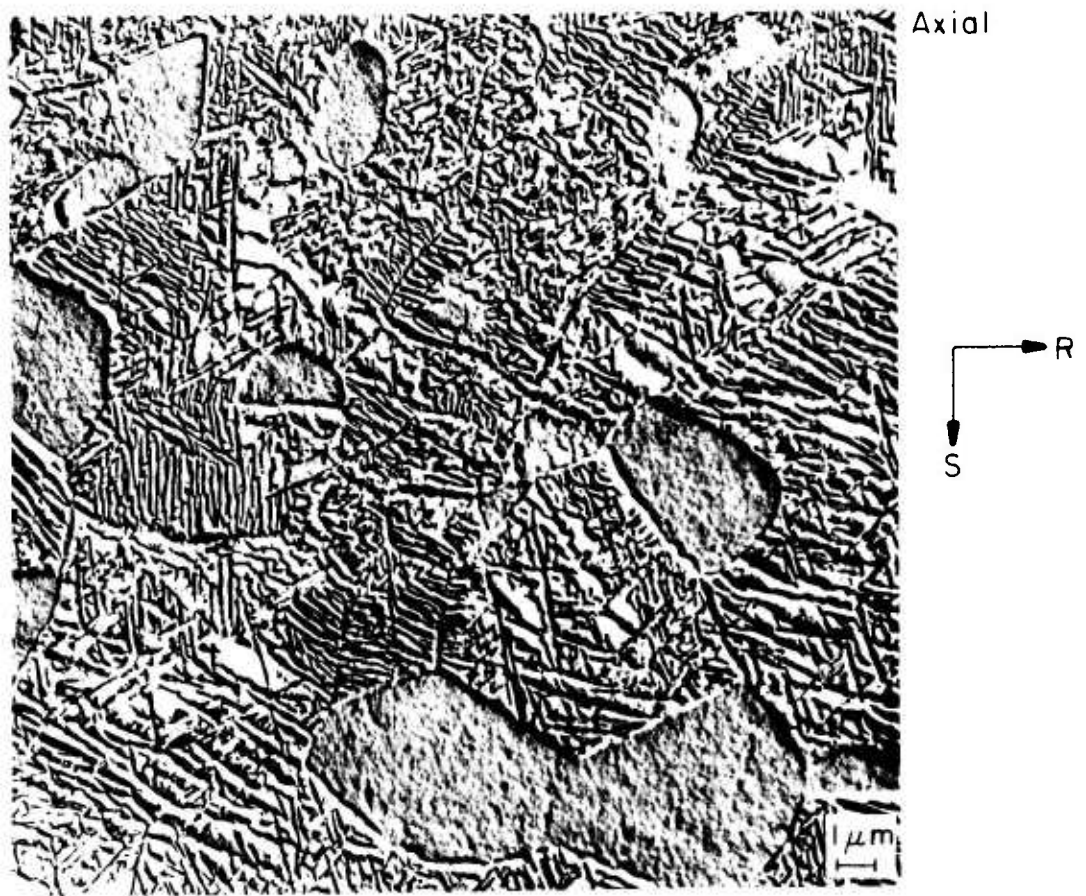
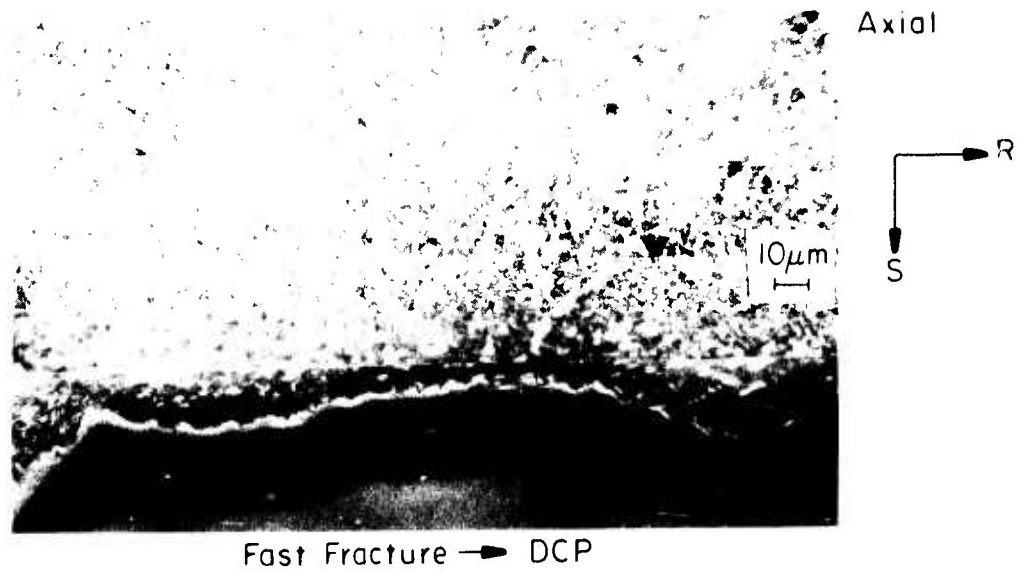

Figure 161 . Alloy 227, sample 7SR20. Crack path X500, surface replica X5200.

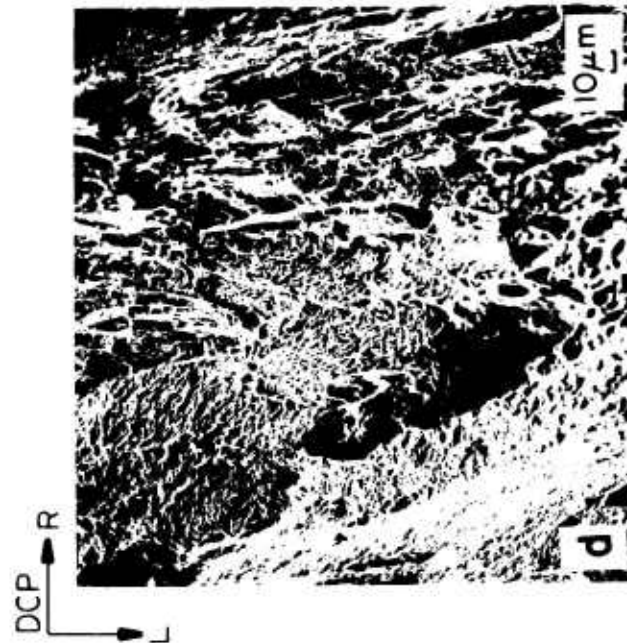
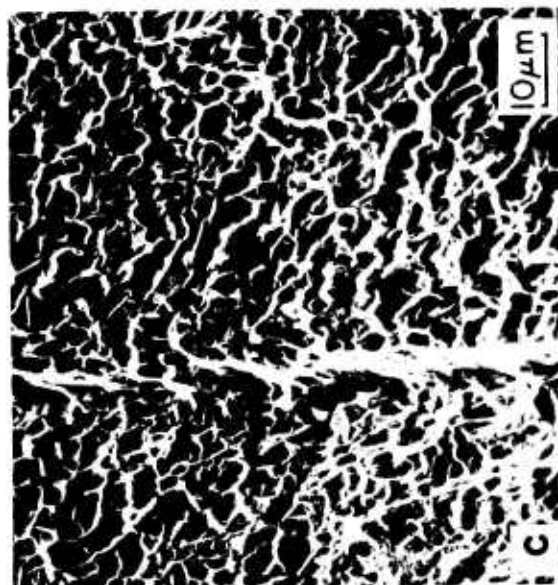

Figure 162. Alloy 227, sample 7SR20. SEM of fracture surface (a) X25, (b) X300 - precrack/fast fracture transition, (c) X1000 - close to transition, (d) X200, (e) X900 - fast fracture.

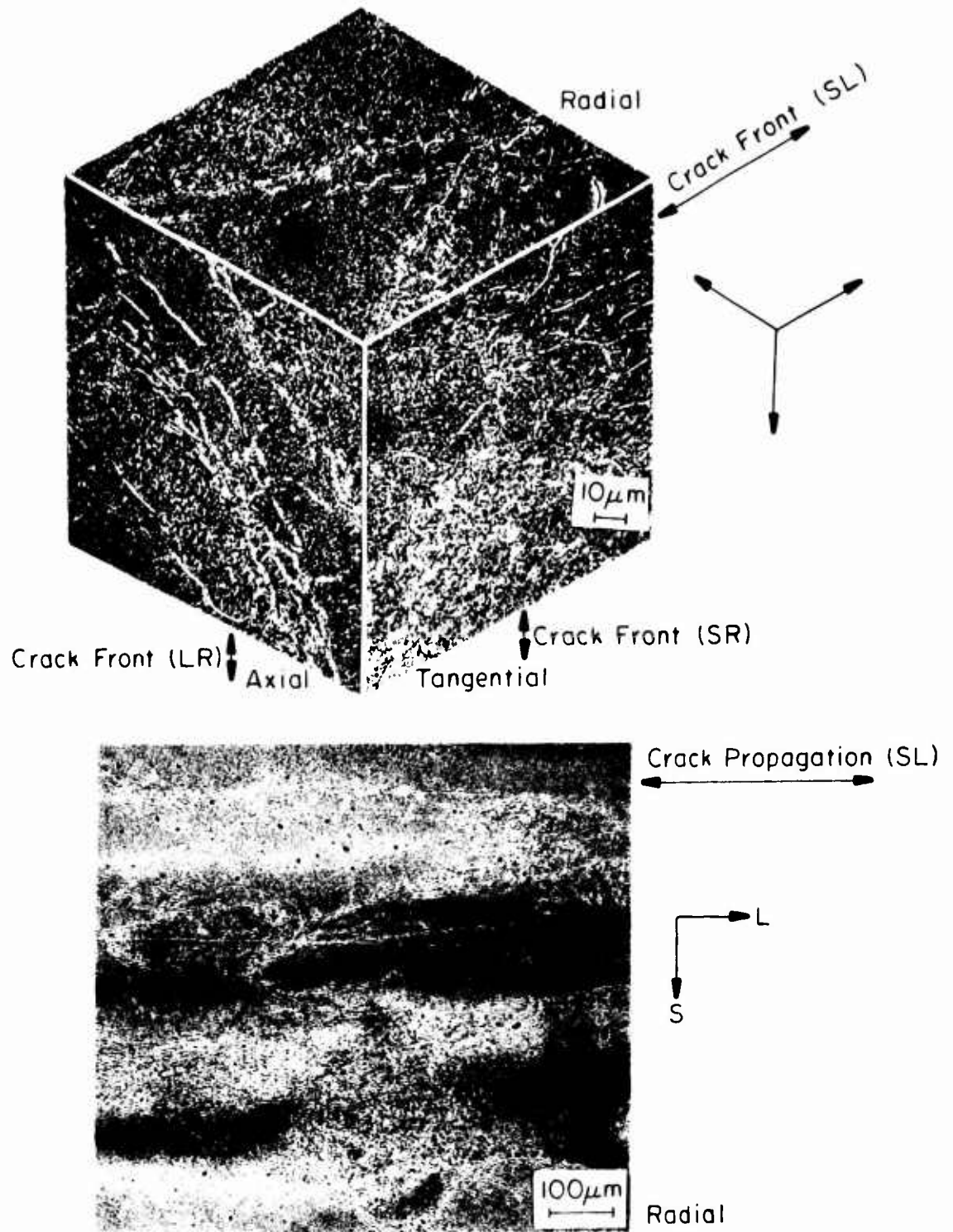
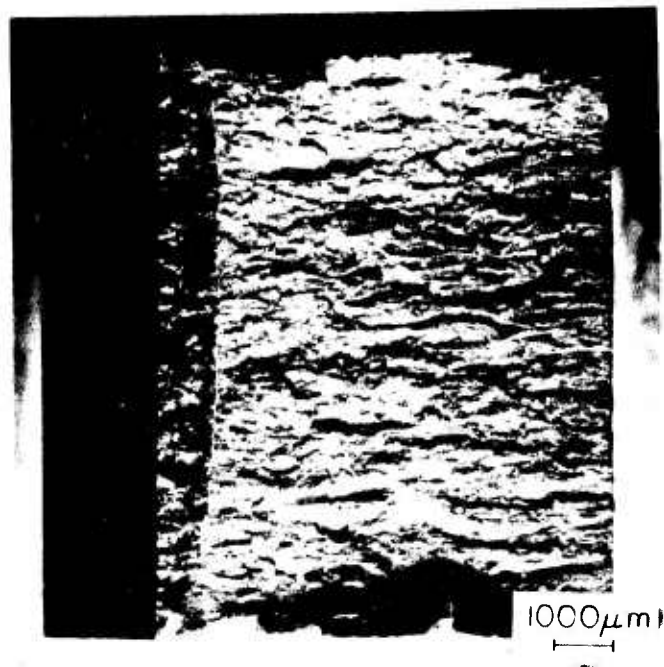
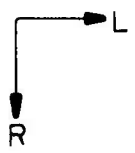

Figure 163. Alloy 334(10Mo-6Cr-2.5Al). Six inch billet full piece center samples 4SLC2 and 4LRC2 (Table LXVI). Solution annealed 1350F-4 hr Wq plus 1225F-2 hr WQ, aged 900F-96 hr. Isometric X500, radial face X100.

YS(ksi):	147 (L)	RA(%):	50 (L)	K _Q (ksi/in):	126 (LR)
	151 (T)		33 (T)		70 (SL)



Fast Fracture



1000 μm



Radial

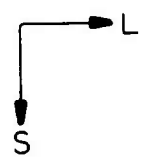

1 μm

Figure 164. Alloy 334, sample 4SLC2. Fracture surface X8, surface replica X5200.

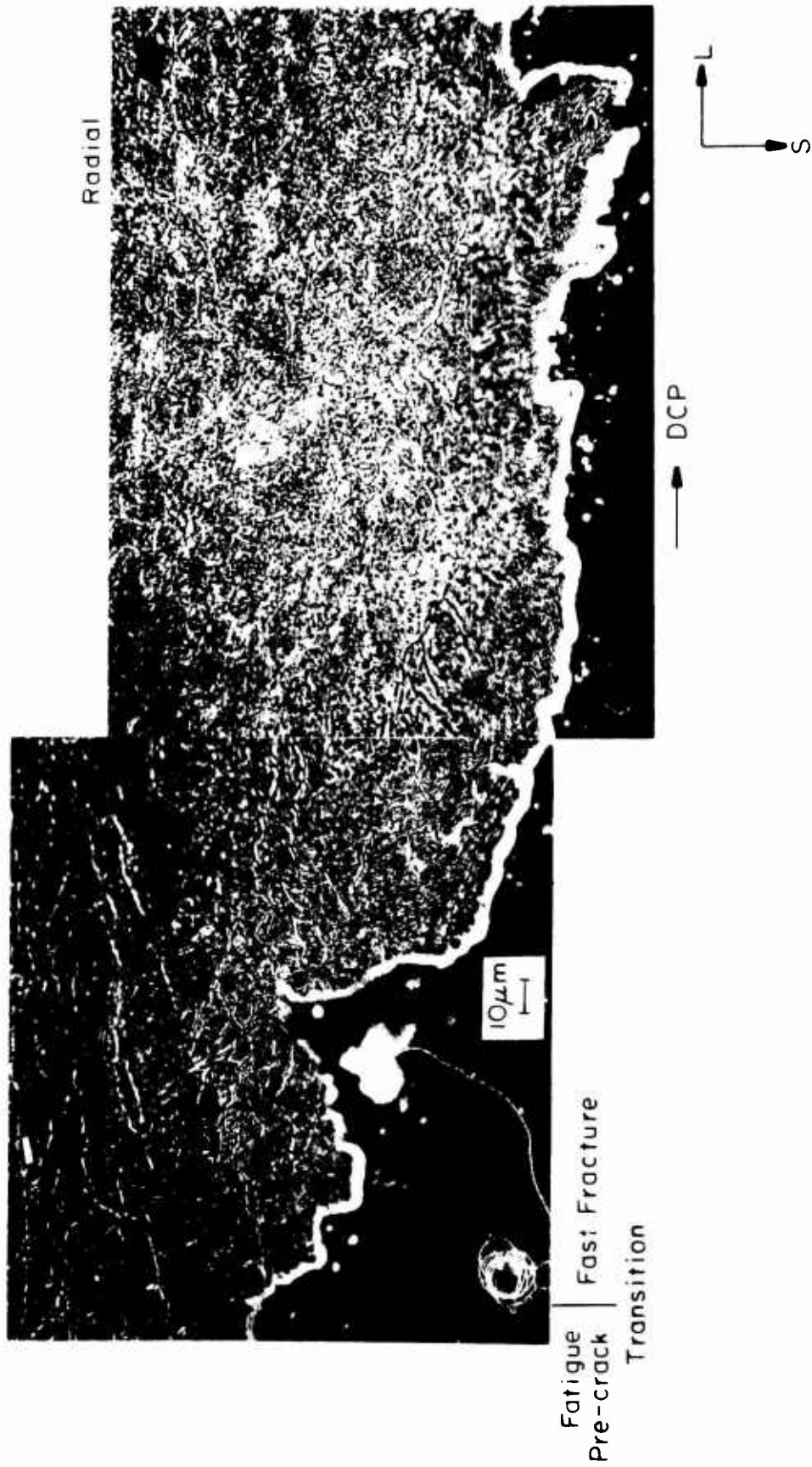
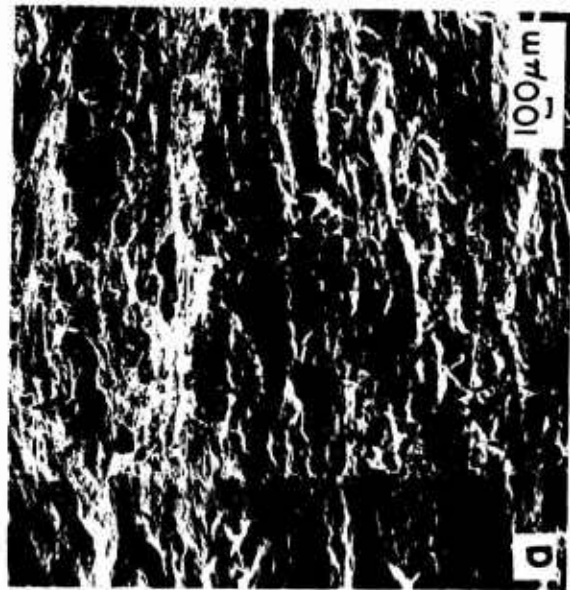

Figure 165. Alloy 334, sample 4SLC2. Crack path X500.



DCP → L
→ R

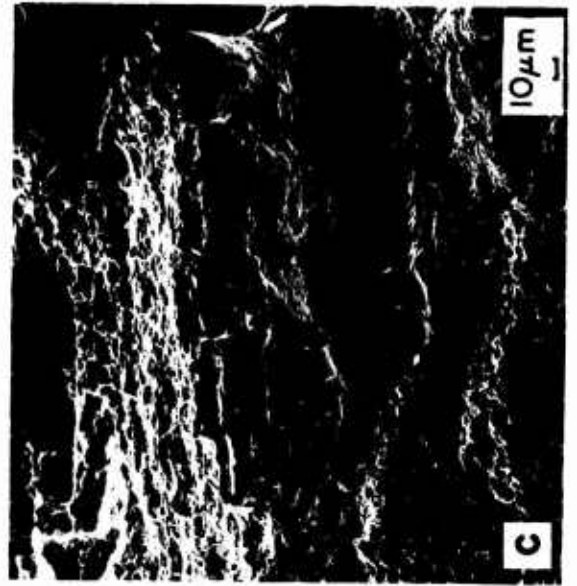
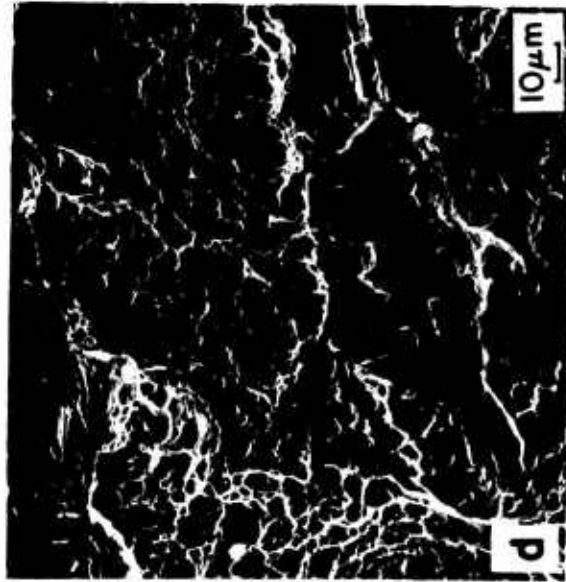

Figure 166. Alloy 334, sample 4SLC2. SEM of fracture surface (a) X25, (b) X250-precrack/fast fracture transition, (c) X250, (d) X500 - fast fracture.

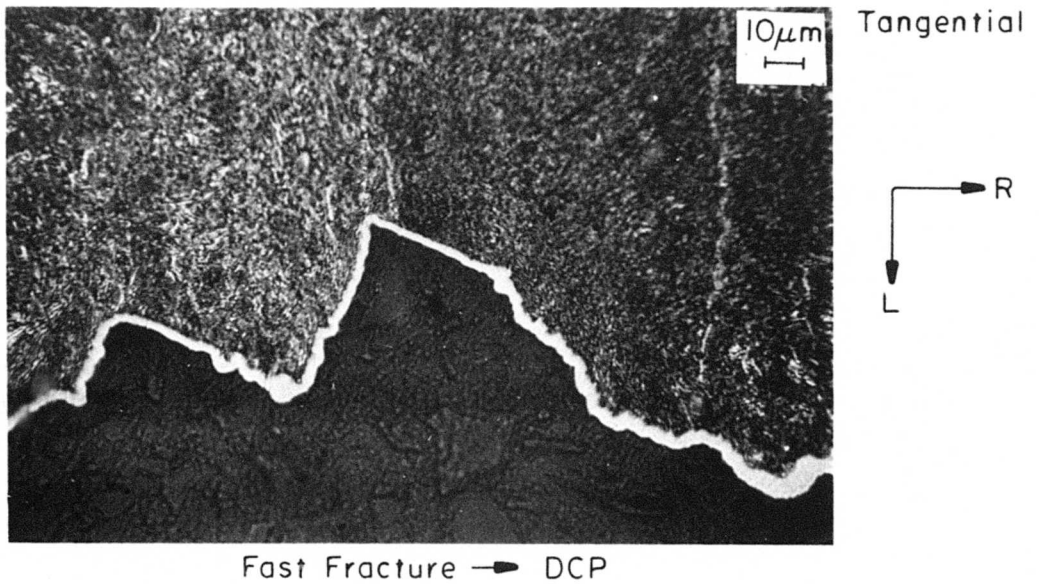
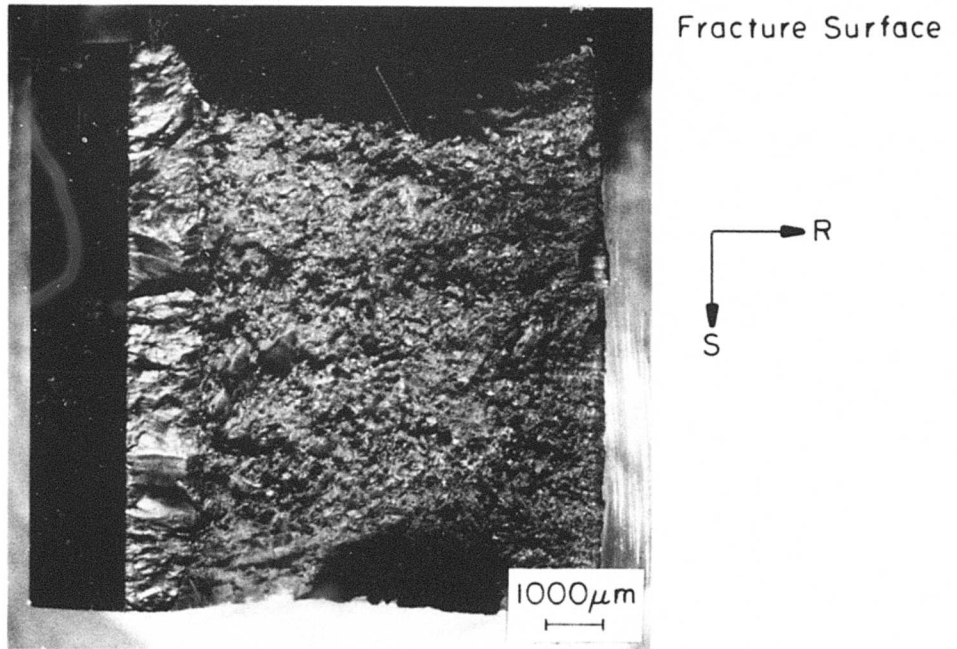

Figure 167. Alloy 334, sample 4LRC2. Fracture surface X8, crack path X500.

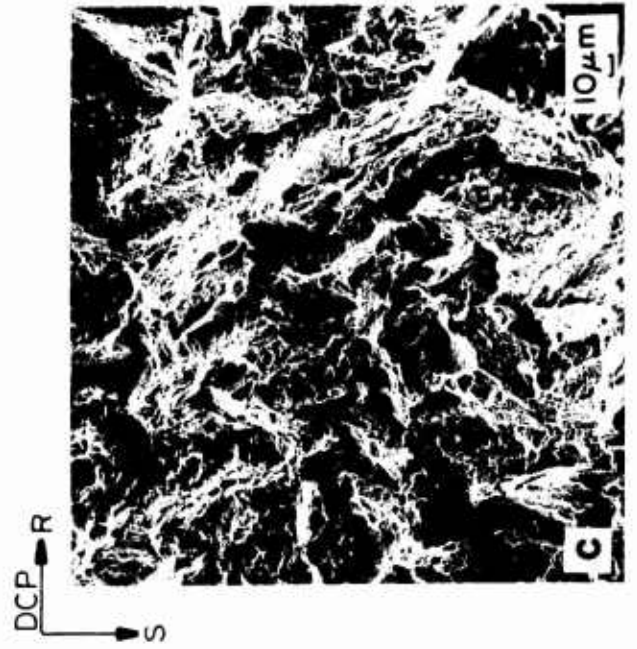

Figure 168. Alloy 334, sample 4LRC2. SEM of fracture surface (a) X25, (b) X250 - precrack/
fast fracture transition, (c) X250, (d) X500 - fast fracture.



Tangential

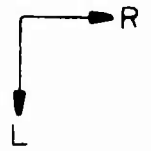

Figure 169. Alloy 334, sample 4LRC2. Surface replica X5200.

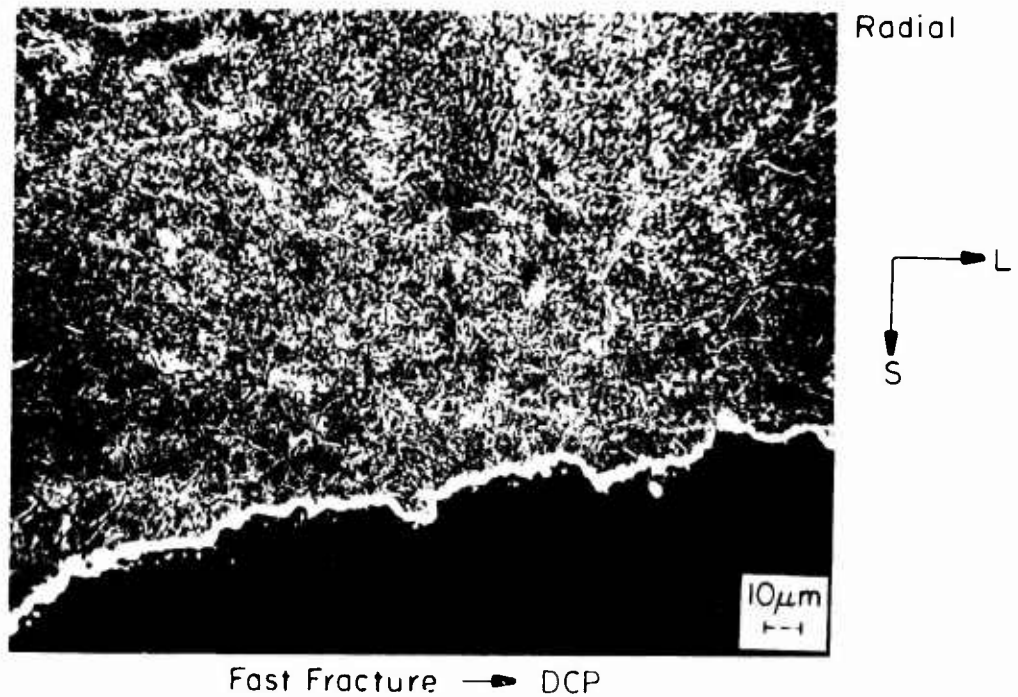
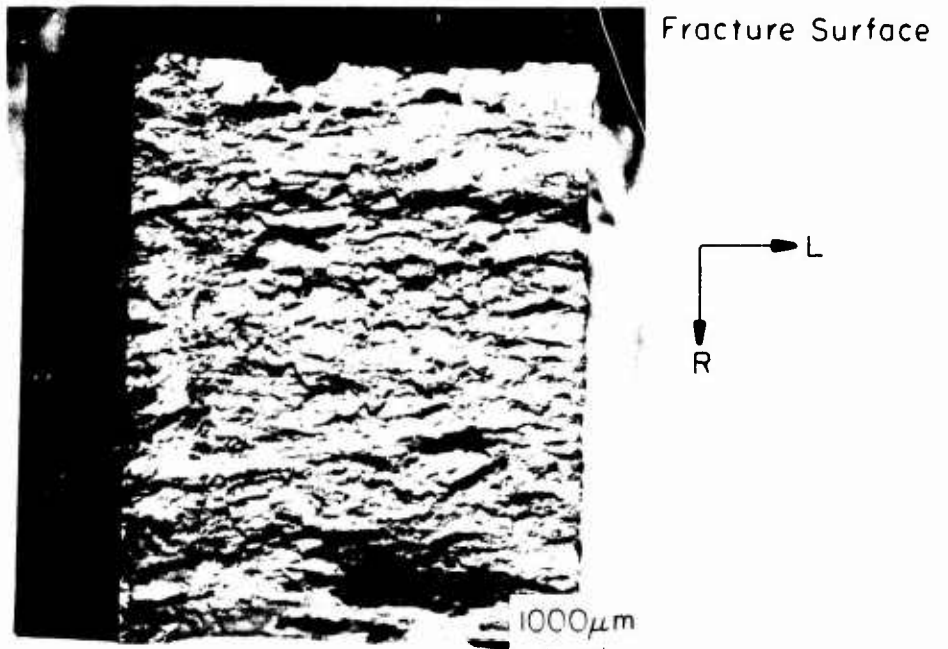

Figure 170. Alloy 334(10Mo-6Cr-2.5Al). Six inch billet full piece, center sample 4SLC4. (Table LXXII). Solution annealed 1350F-4 hr WQ plus 1225F-2 hr WQ, aged 1000F-96 hr. Fracture surface X8, crack path X500.

YS(ksi):	144 (L)	RA(%):	37 (L)	K _Q (ksi/in):	-- (LR)
	146 (T)		34 (T)		75 (SL)

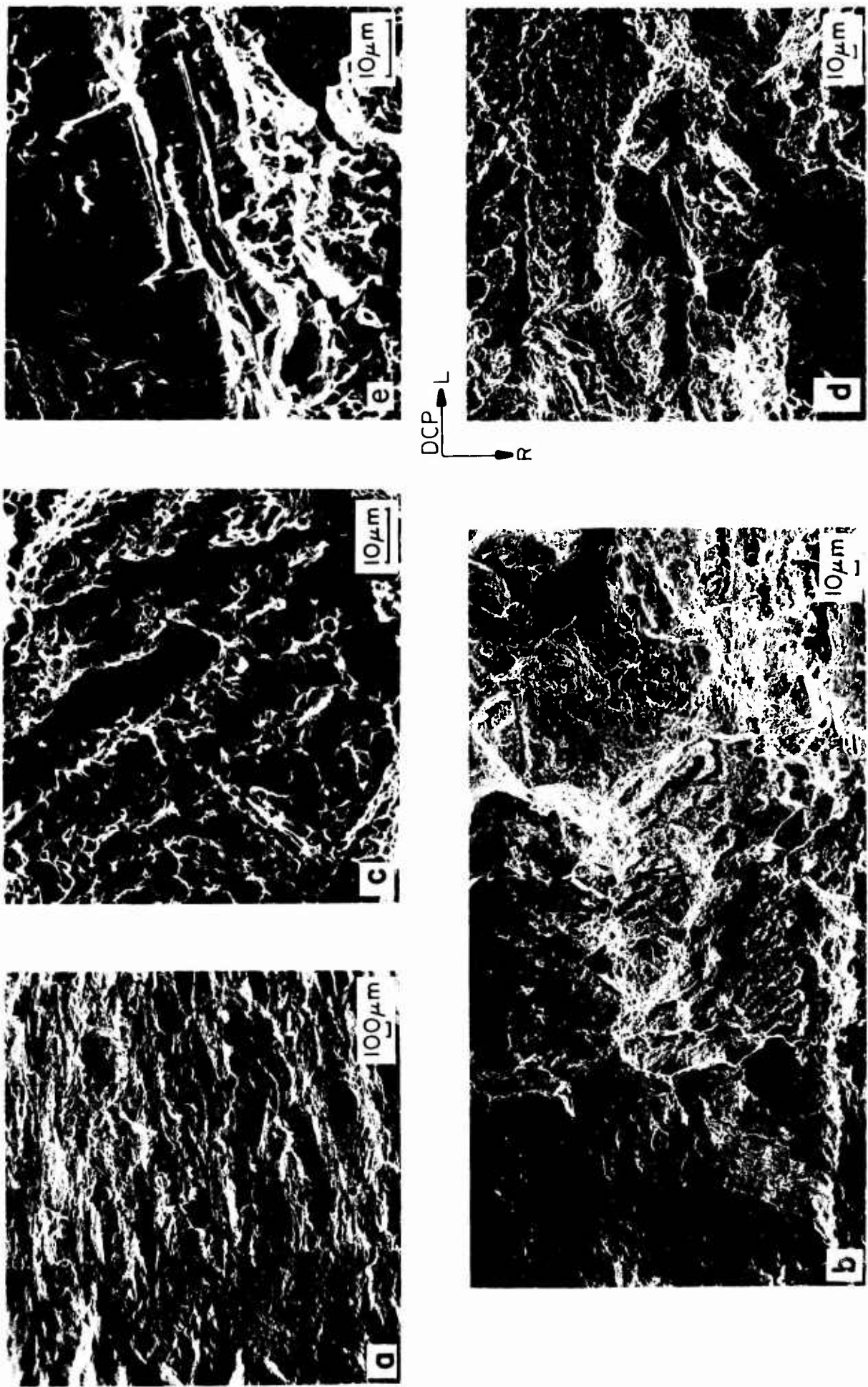

Figure 171. Alloy 334, sample 4SLC4. SEM of fracture surface (a) X25, (b) X250 - precrack/fast fracture transition, (c) X1000 - fast fracture transition, (d) X200, (e) X1000 - fast fracture.

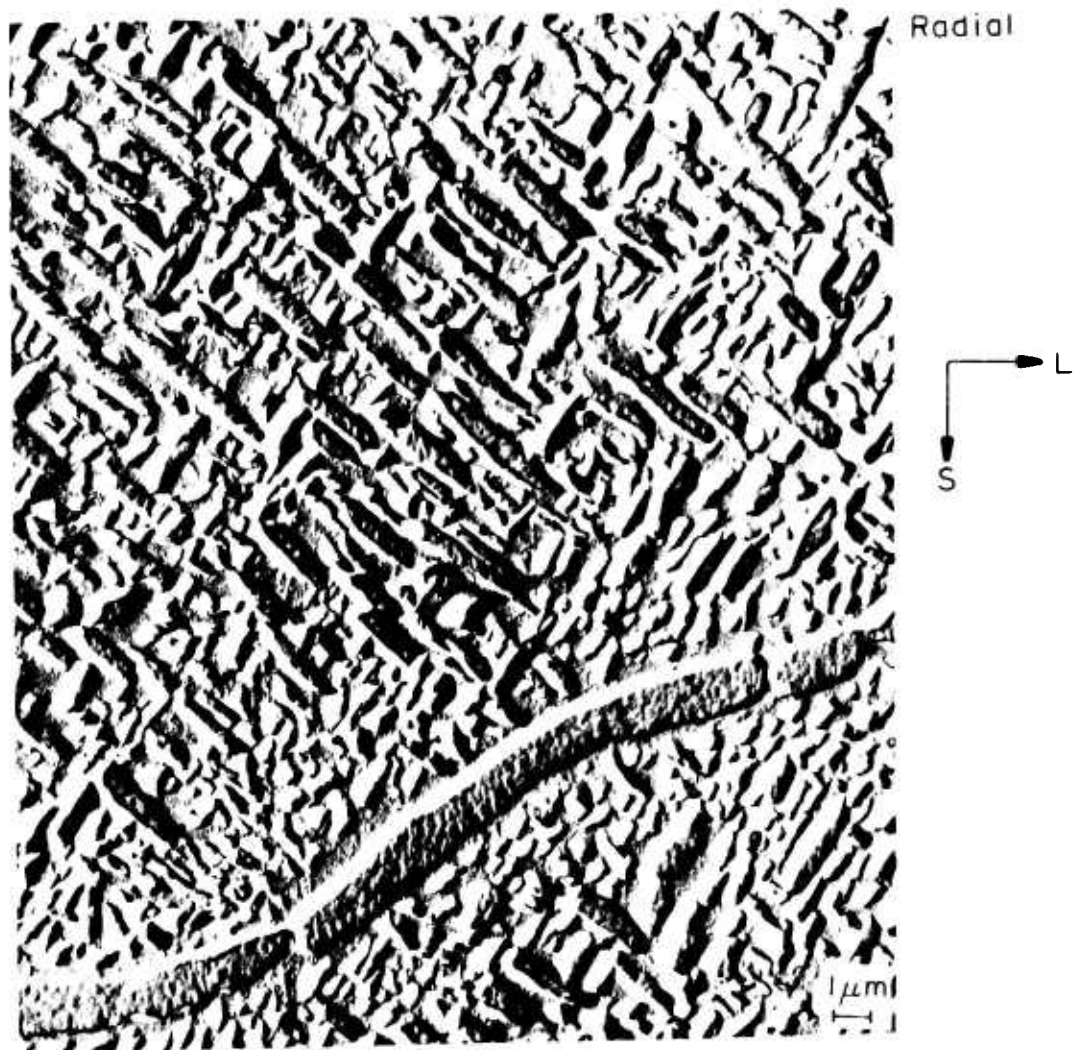

Figure 172 . Alloy 334, sample 4SLC4. Surface replica X5200.

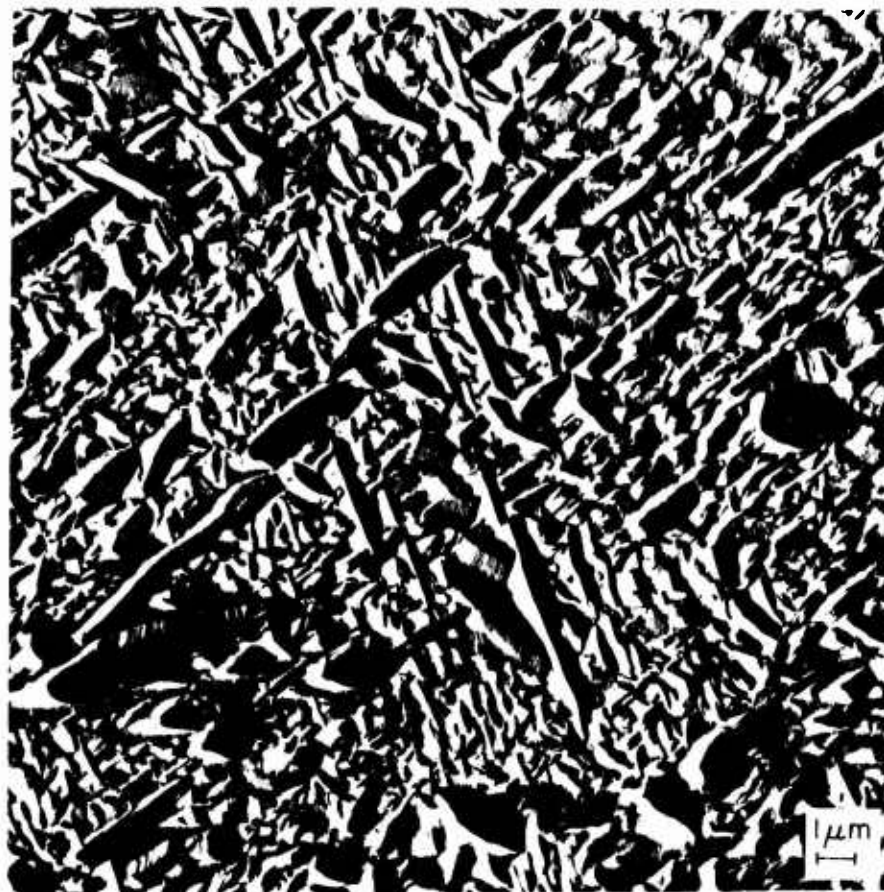
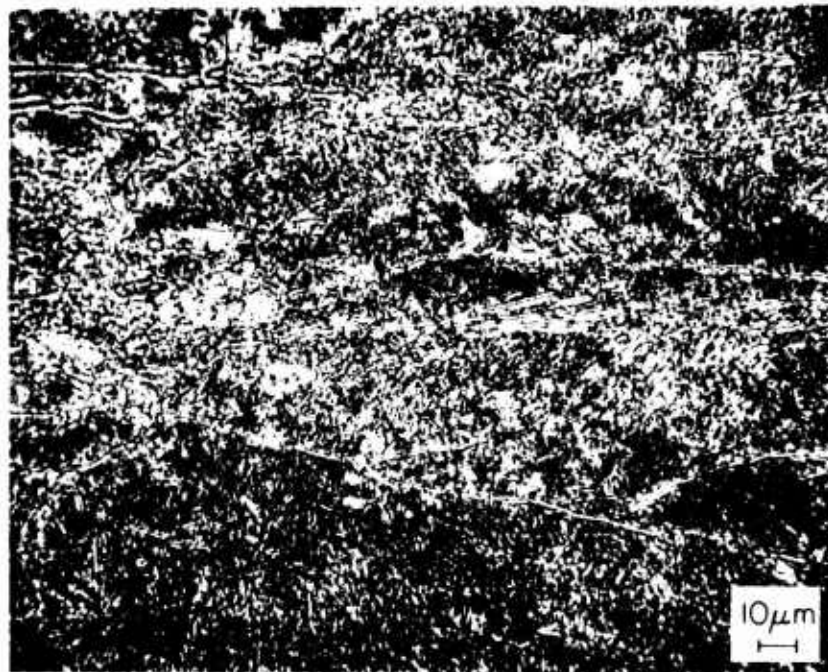

Figure 173. Alloy 334(10Mo-6Cr-2.5Al). Six inch billet full piece, edge samples 4SLE2 and 4LRE2 (Table LXVI). Solution annealed 1350F-4 hr WQ plus 1225F-2 hr WQ, aged 900F-96 hr. Radial face X500, surface replica X5200.

YS(ksi):	155 (L)	RA(%):	53 (L)	K _Q (ksi/in):	134 (LR)
	150 (T)		23 (T)		59 (SL)

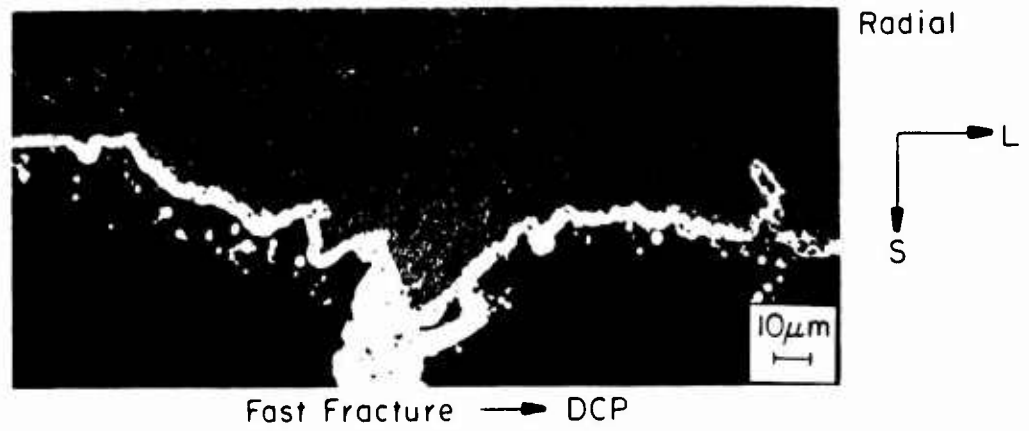
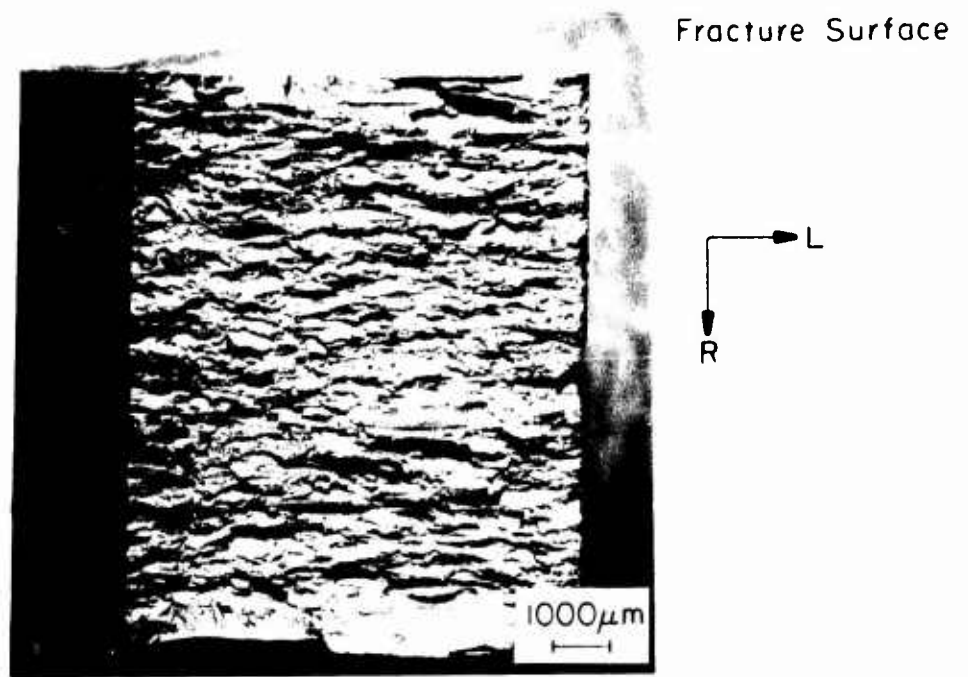

Figure 174. Alloy 334, sample 4SLE2. Fracture surface X8, crack path X500.

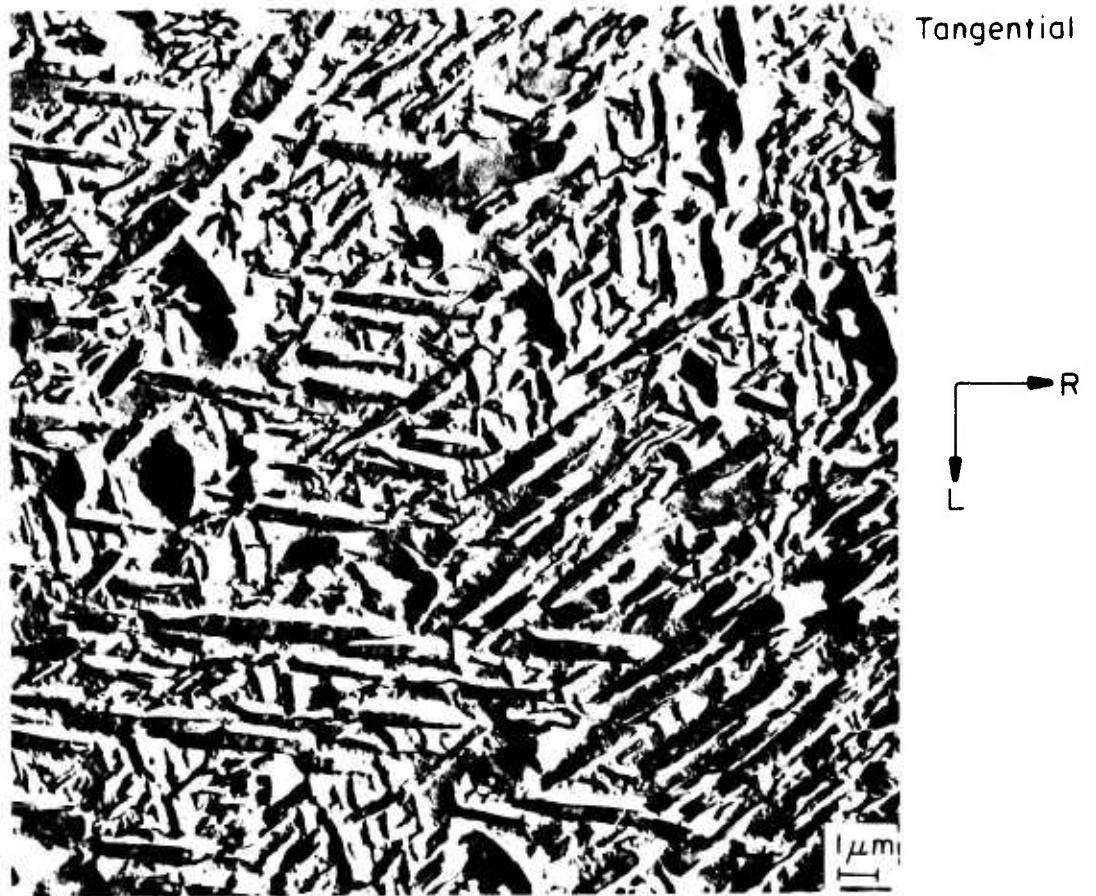
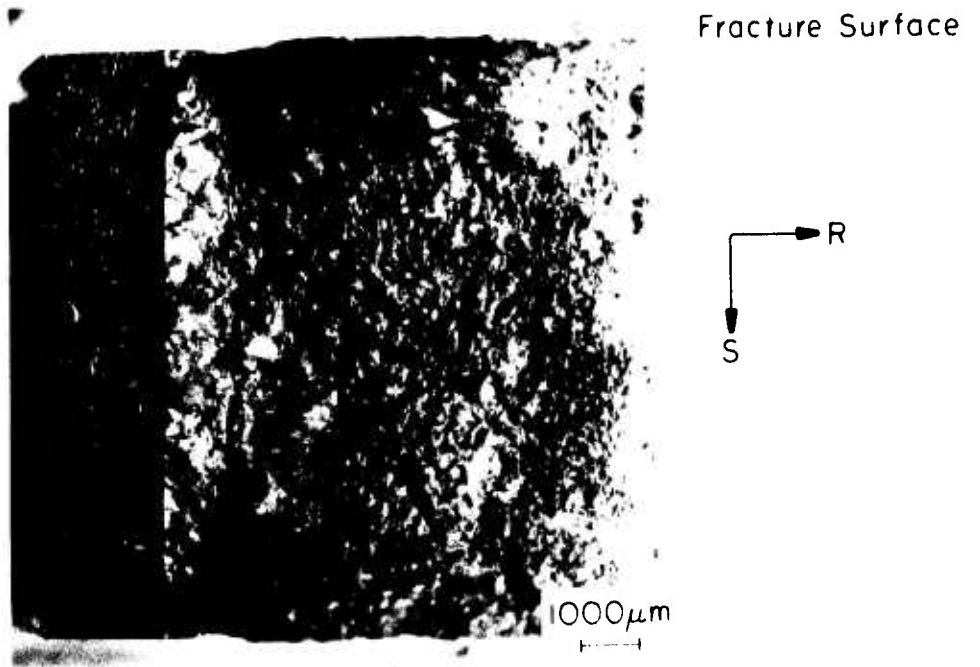

Figure 175. Alloy 334, sample 4LRE2. Fracture surface X8, surface replica X5200.

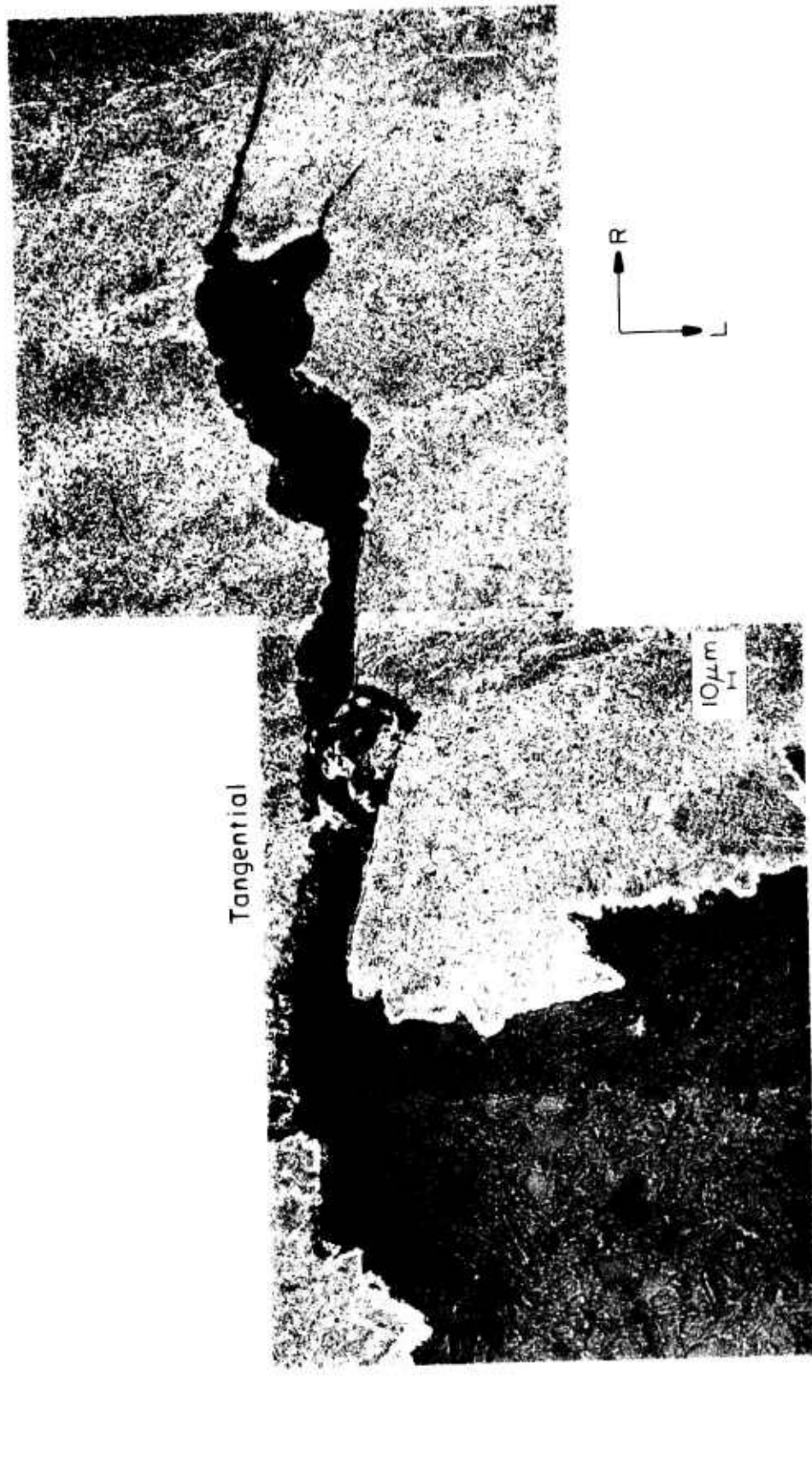

Figure 176. Alloy 334, sample 4LRE2. Crack path X250.

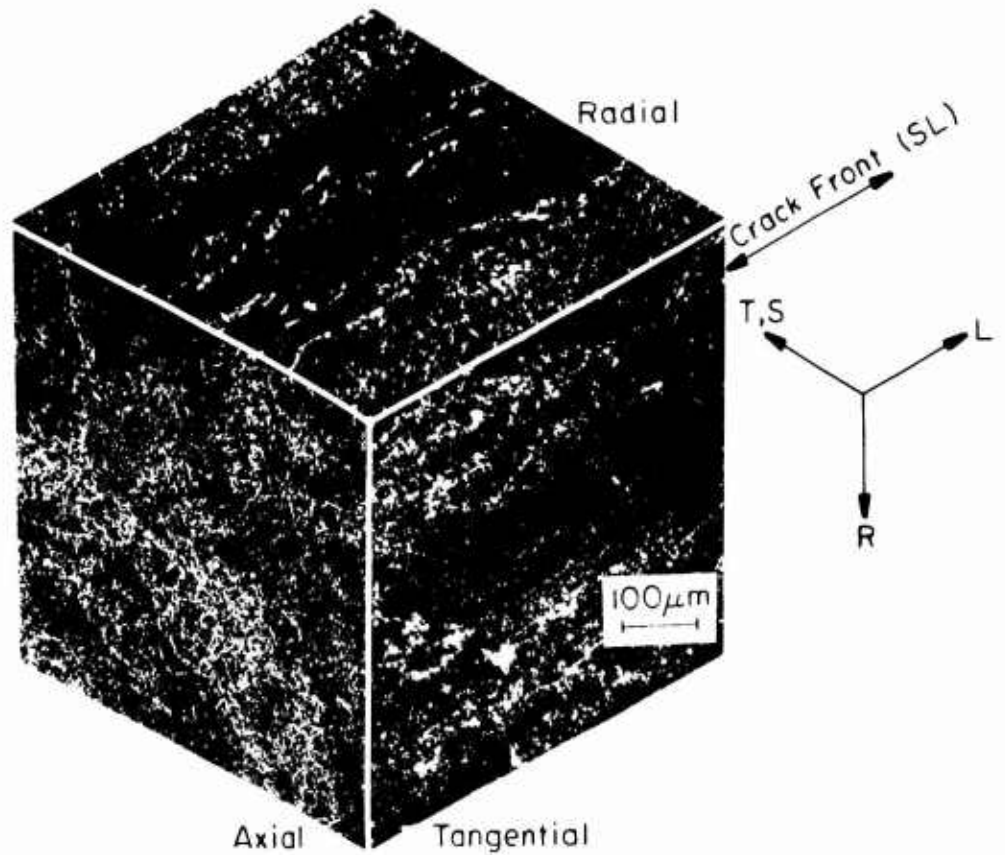

Figure 177. Alloy 227(7Mo-4Cr-2.5Al). Six inch billet full piece, center samples 7SLC1 and 7LRC2 (Table LXVII). Solution annealed 1450F-2 hr WQ plus 1350F-8 hr WQ, aged 925F-8 hr. Isometric X100, surface replica X5200.

YS(ksi):	151 (L)	RA(%):	36 (L)	K _Q (ksi/in):	84 (LR)
	152 (T)		18 (T)		50 (SL)

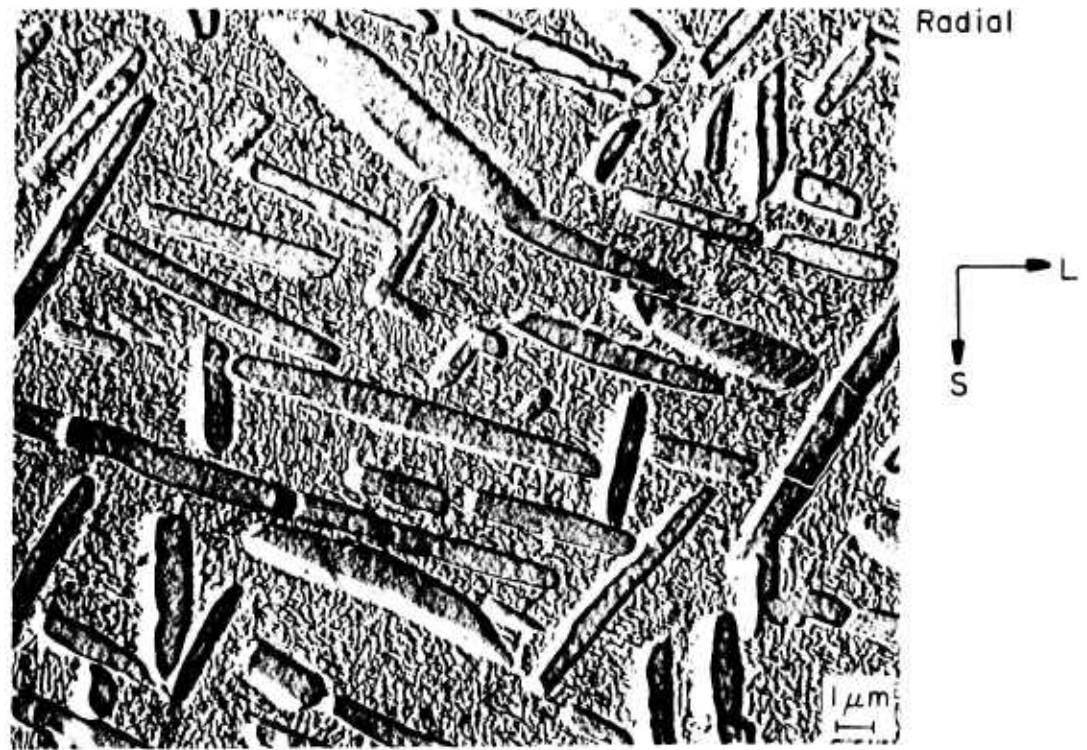
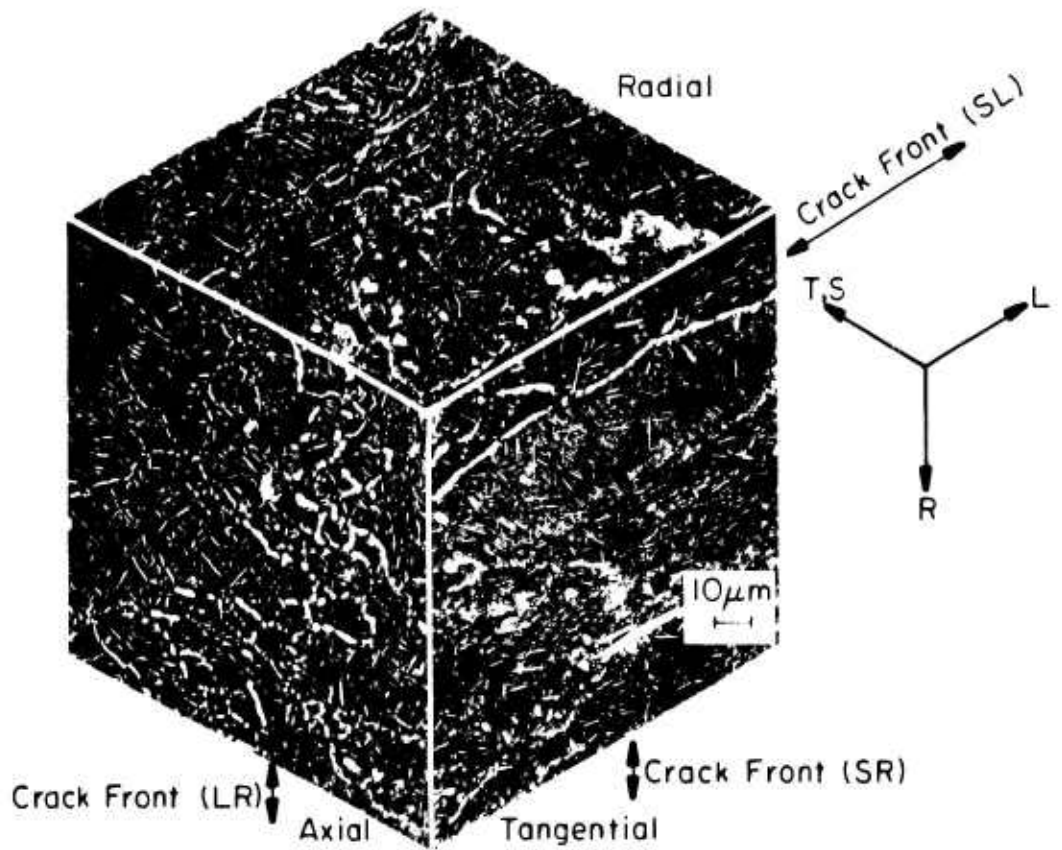
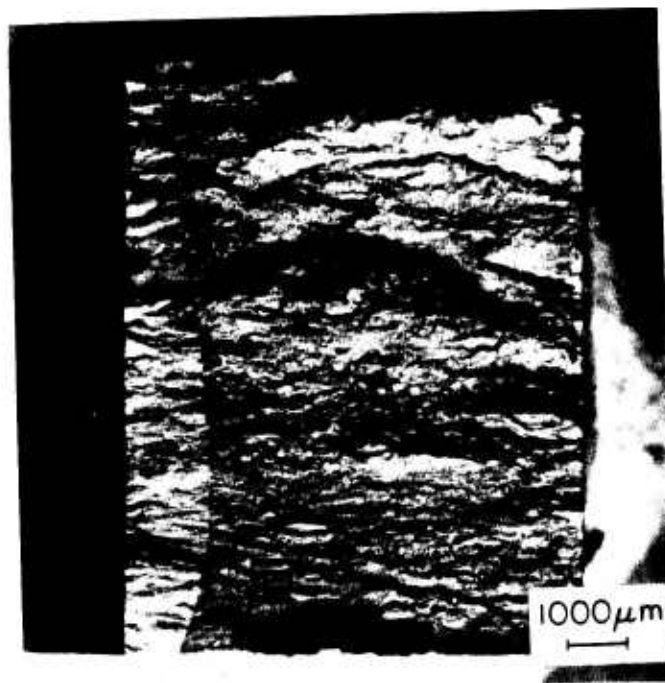

Figure 178. Alloy 227, sample 7SLC1. Isometric X500, surface replica X5200.



Fracture Surface

Figure 179. Alloy 227, sample 7SLC1. Fracture surface X8.

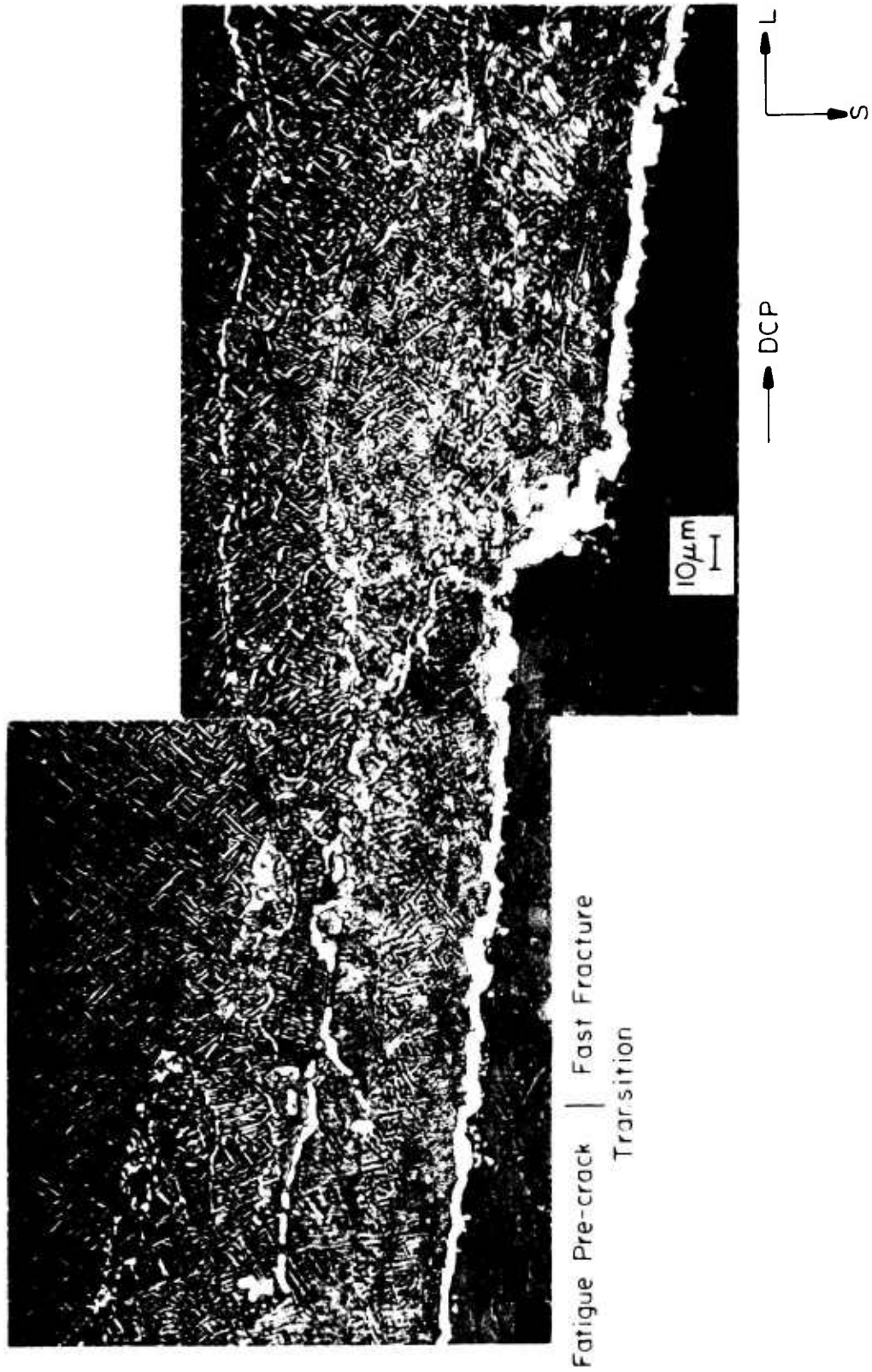

Figure 180. Alloy 227, sample 7SLC1. Crack path X500.

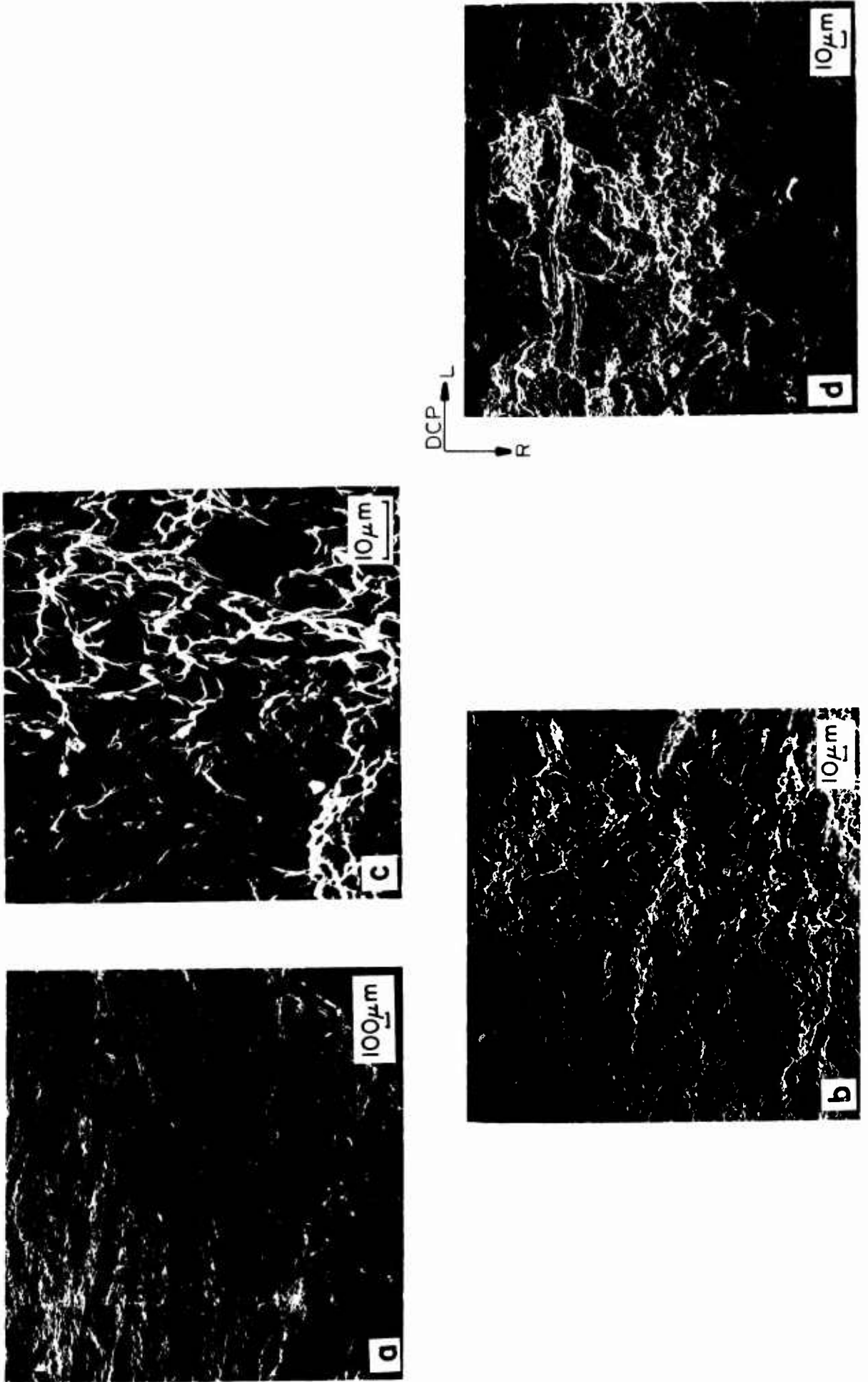
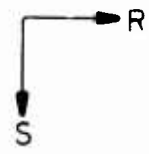

Figure 181. Alloy 227, sample 7SLC1. SEM of fracture surface (a) X25, (b) X250 - precrack/fast fracture transition, (c) X1000 - fast fracture close to transition, (d) X250 - fast fracture.



Fracture Surface



1000 μm

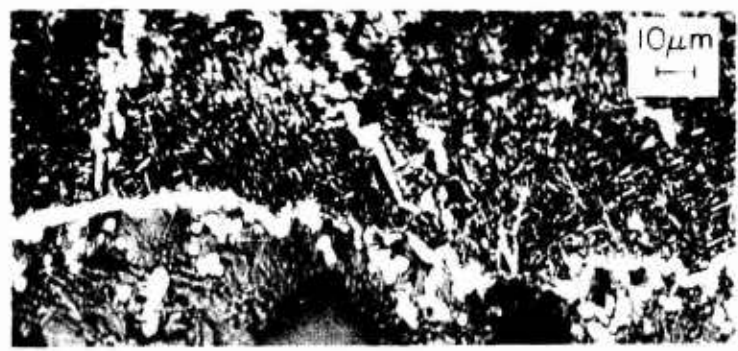

Tangential

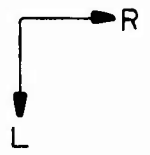

Fatigue Pre-crack | Fast Fracture Transition → DCP

Figure 182. Alloy 227, sample 7LRC2. Fracture surface X8, crack path X500.

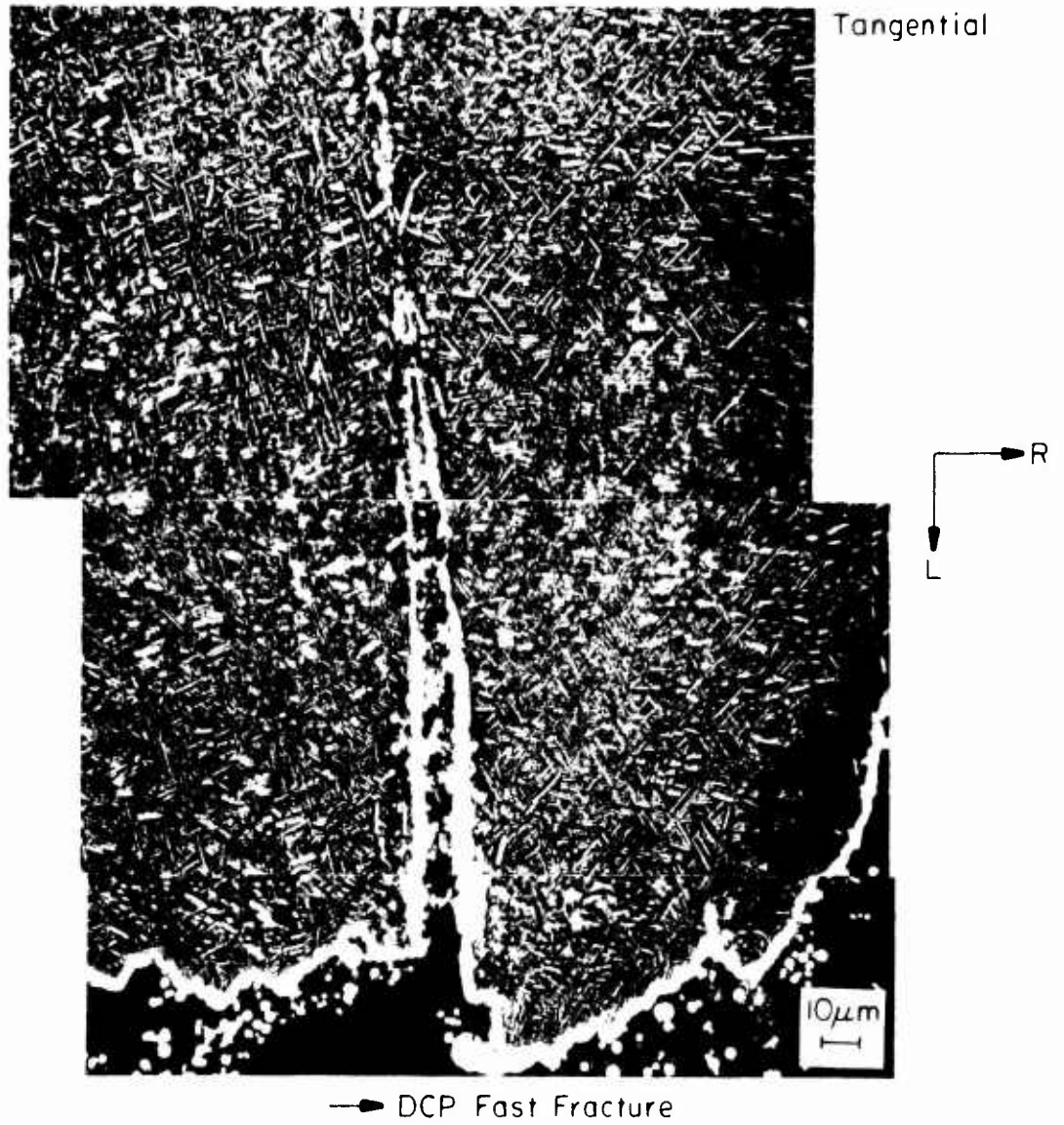

Figure 183. Alloy 227, sample 7LRC2. Crack path X500. Note extended branch crack (vertical) with apparent voids ahead of crack tip.

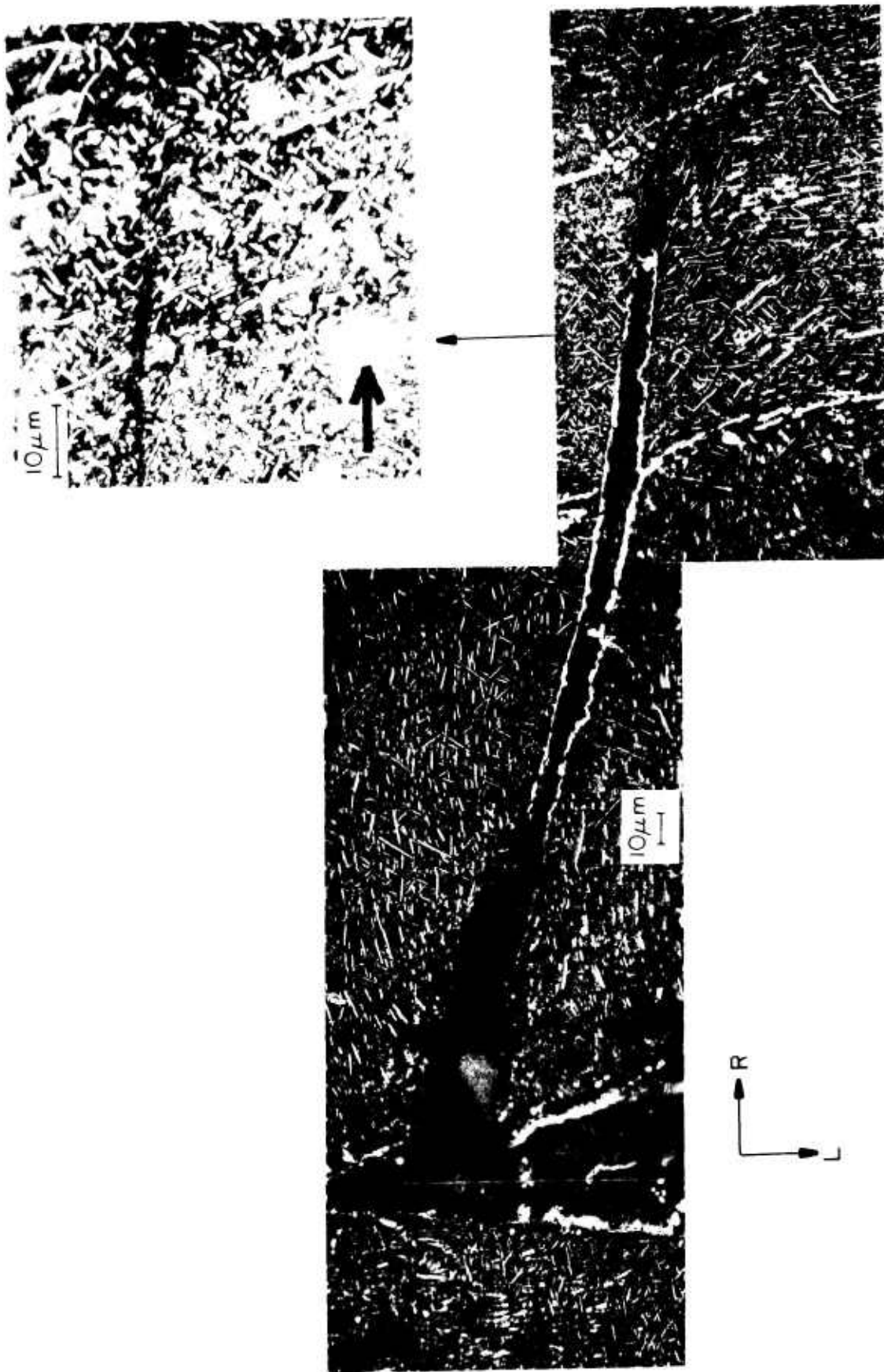

Figure 184. Alloy 227, sample 7LRC2. Crack path X500 (bottom), X1200 (top). Note apparent void (below) and deformed material (ahead) in vicinity of crack tip.

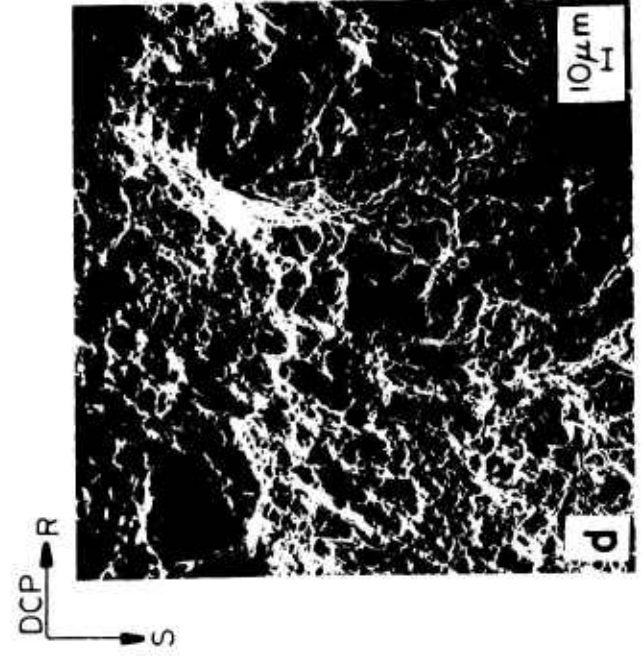
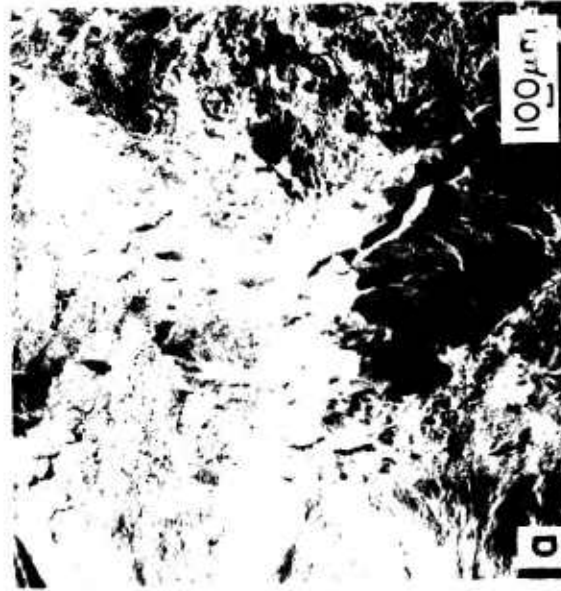
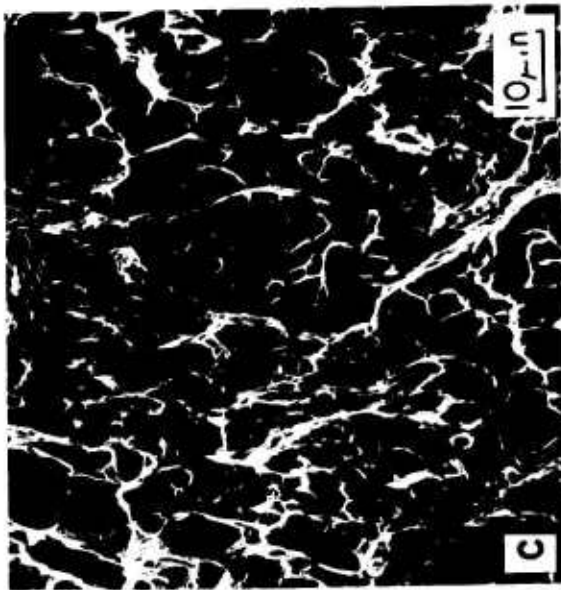
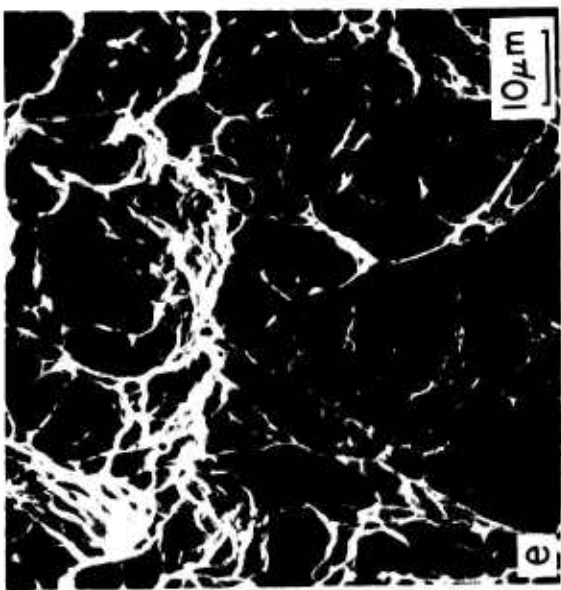
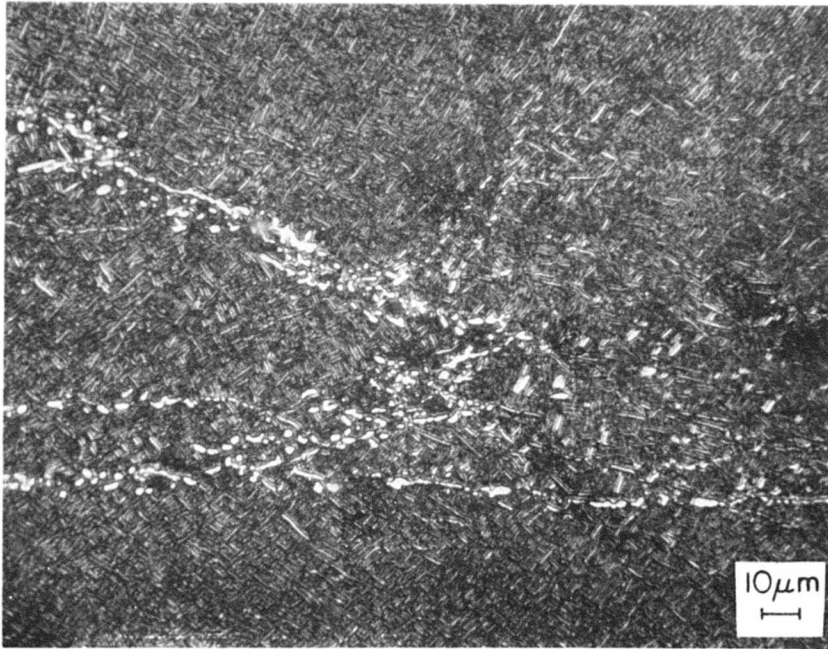
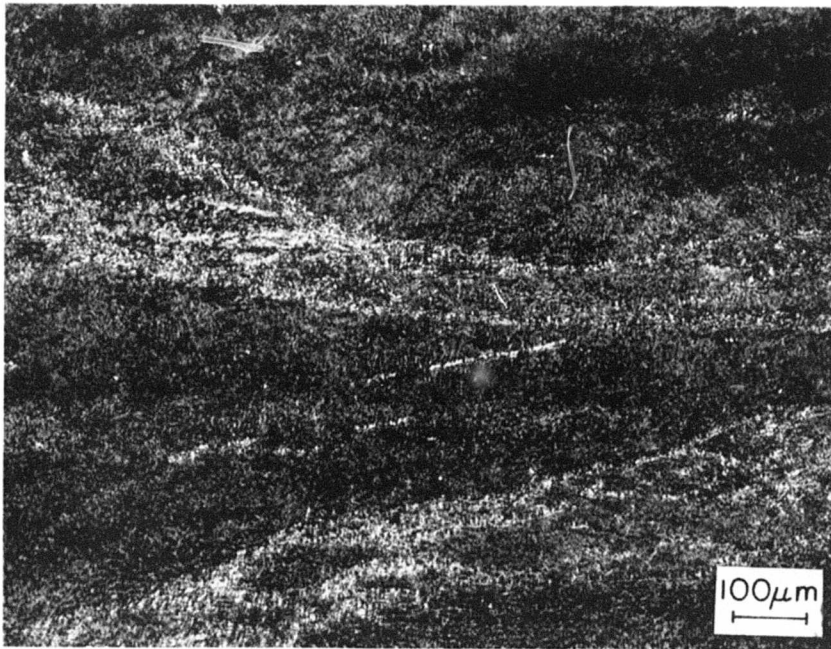
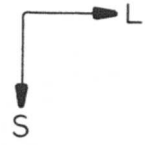

Figure 185. Alloy 227, sample 7LRC2. SEM of fracture surface (a) X25, (b) X250 - precrack/
fast fracture transition, (c) X900 - fast fracture close to transition, (d) X2500, (e) X1000 -
fast fracture.



Radial



Radial



Figure 186. Alloy 227 (7Mo-4Cr-2.5Al). Six inch billet full piece, edge samples 7SLE2 and 7LRE2 (Table LXVII). Solution annealed 1450F - 2 hr WQ + 1350F - 8 hr WQ, aged 925F - 8 hr. Radial face X500 (top), X100 (bottom).
 YS (ksi): 164 (L) RA (%): 40 (L) K (ksi/in.): 62 (LR)
 163 (T) 10 (T) 44 (SL)

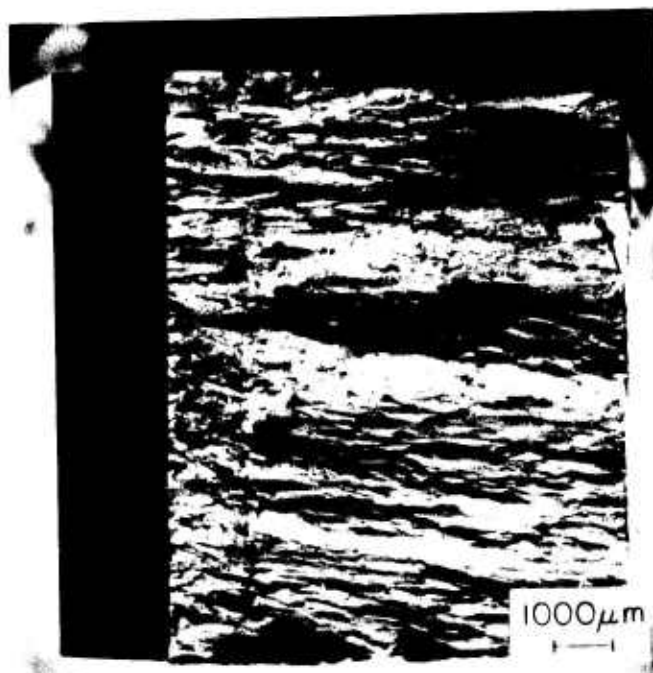

Fracture Surface



Radial

Figure 187. Alloy 227, sample 7SLE2. Fracture surface X8, surface replica X5200.

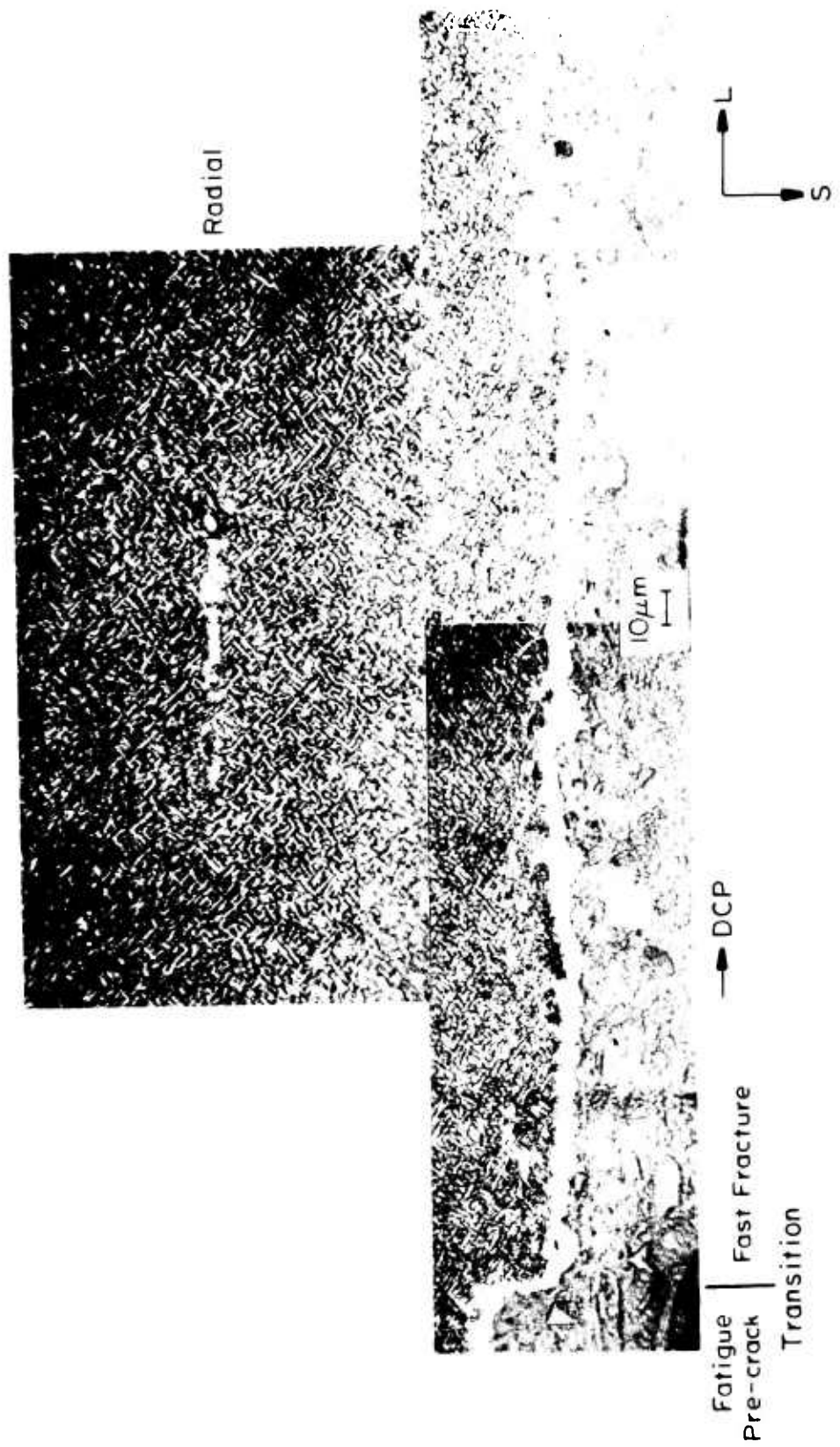

Figure 188. Alloy 227, sample 7SLE2. Crack path X500.

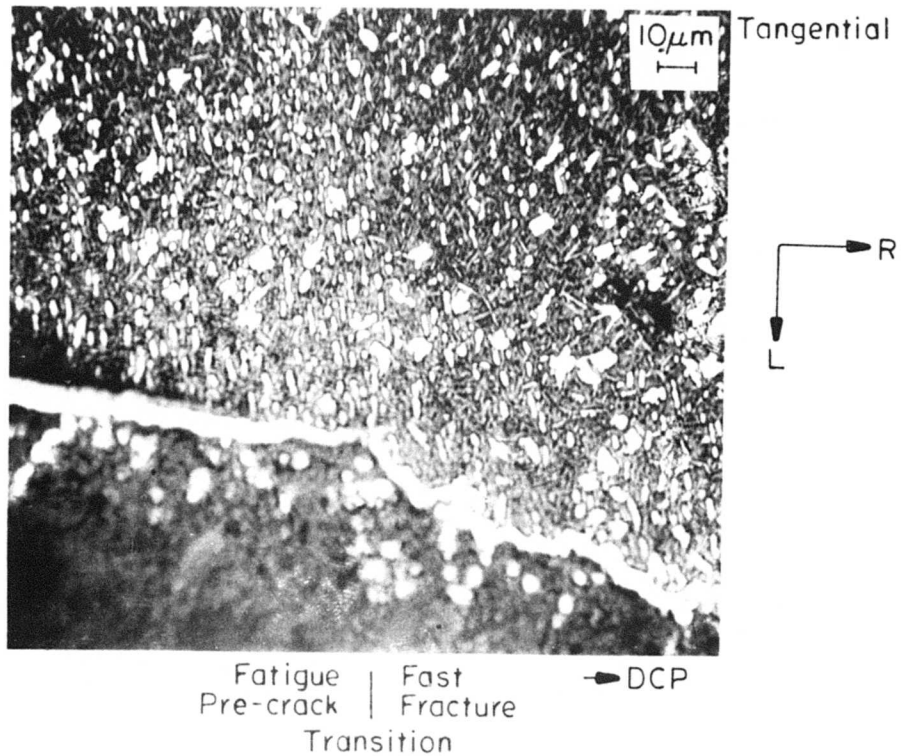

Figure 189. Alloy 227, sample 7LRE2. Fracture surface X8, crack path X500.

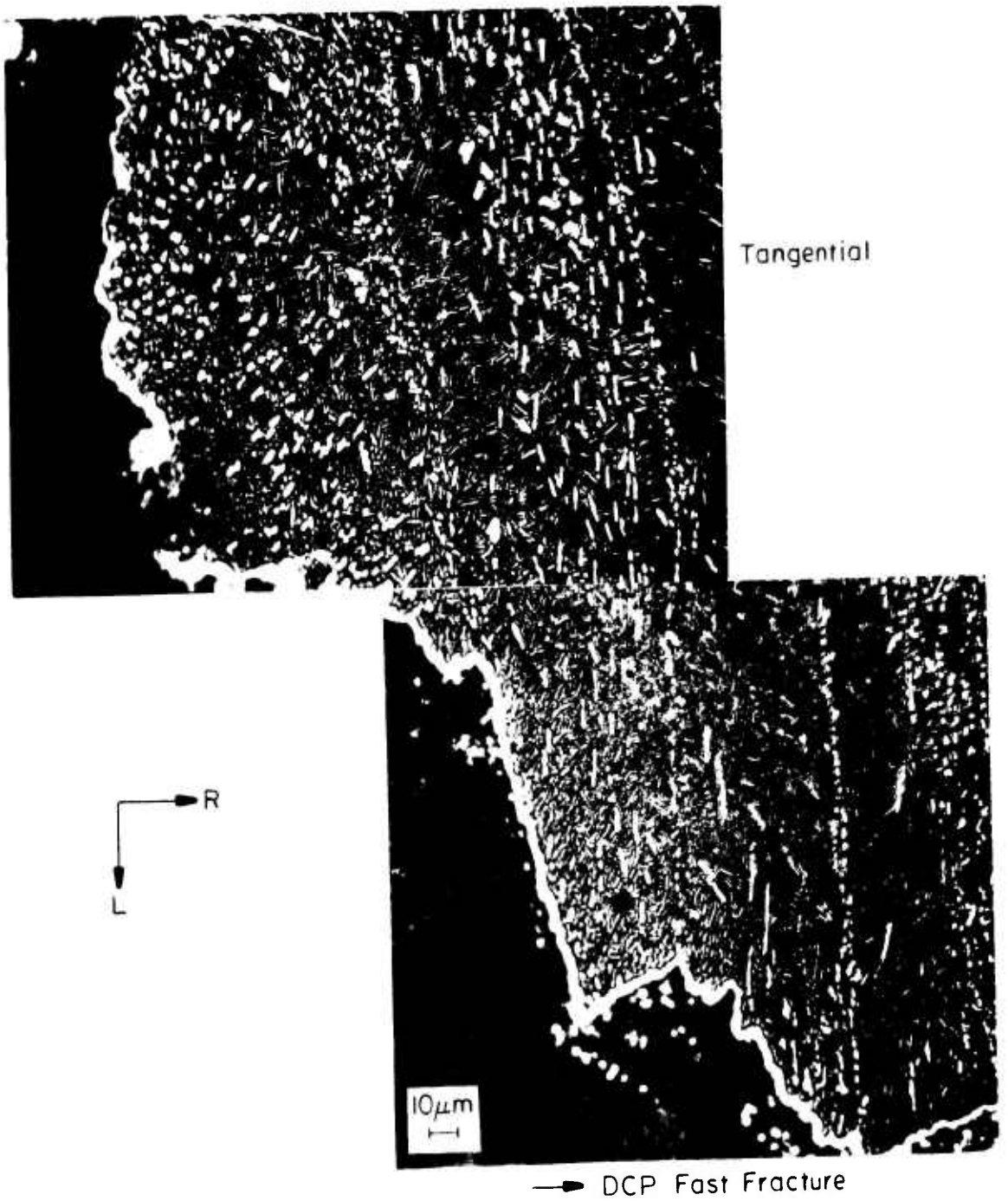

Figure 190. Alloy 227, sample 7LRE2. Crack path X500, note large deviation following alpha particles.

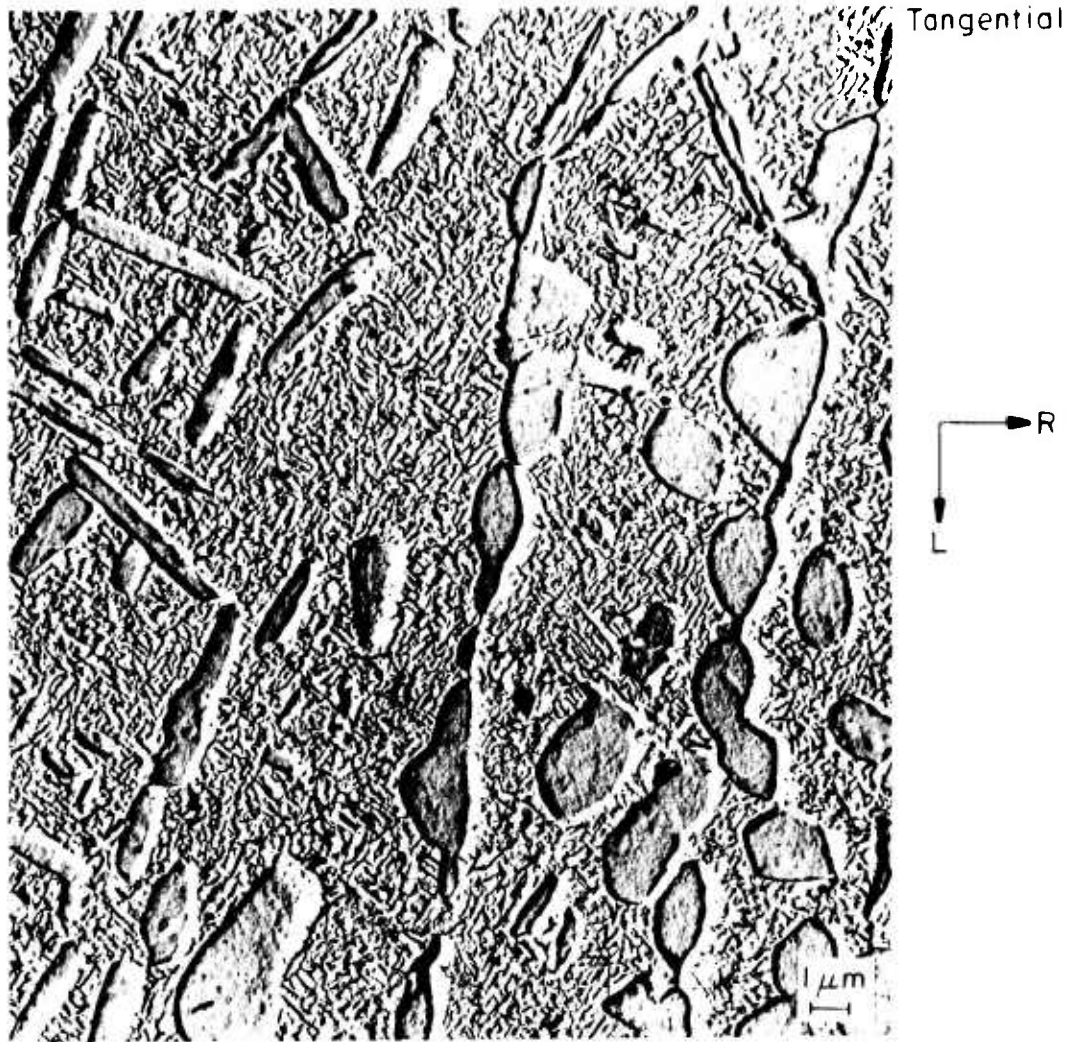

Figure 191. Alloy 227, sample 7LRE2. Surface replica. X5200

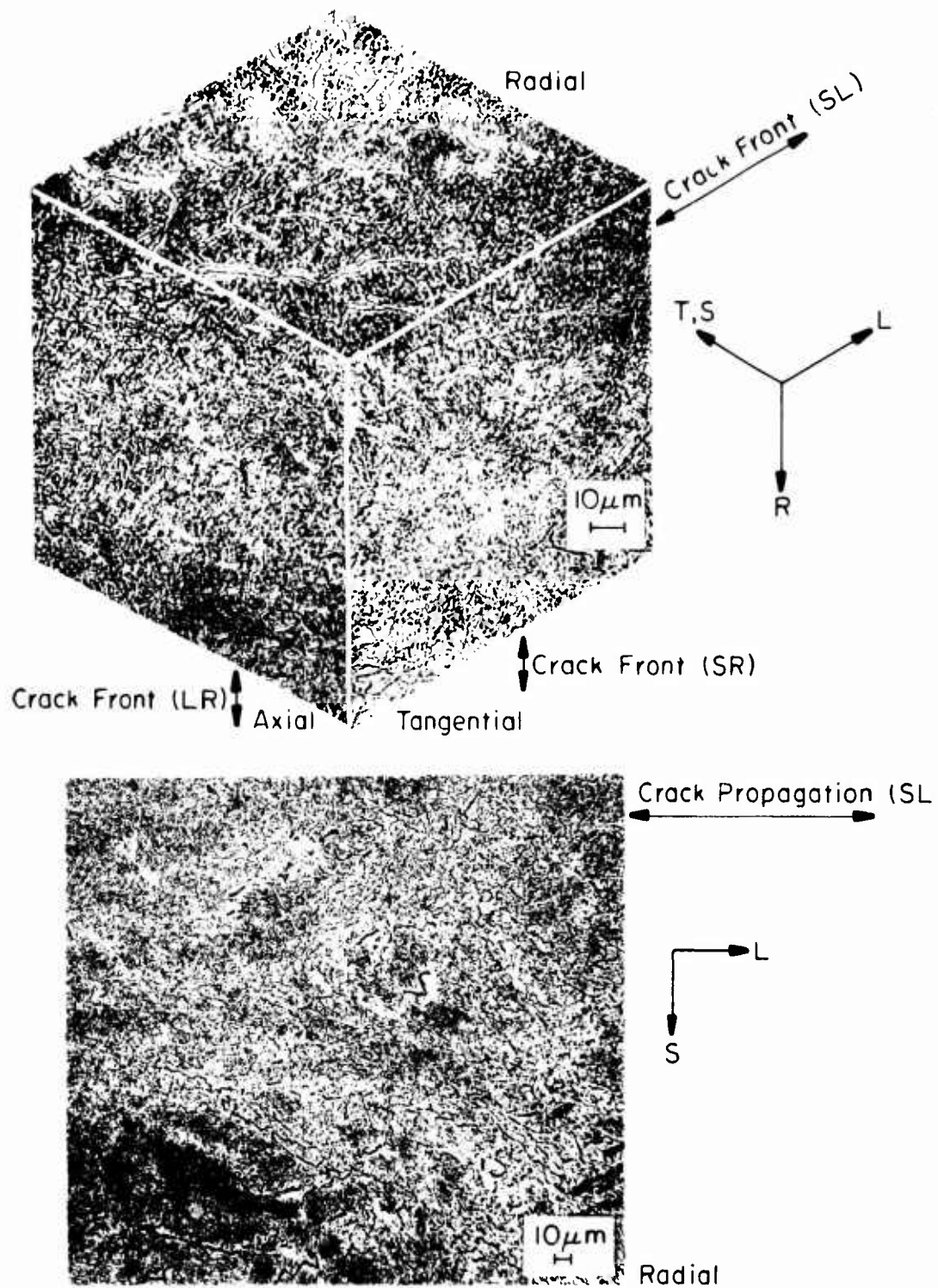

Figure 192. Alloy 253 (10Mo-8V-2.5Al). Six inch billet full piece center samples 3SLC2 and 3LRC1 (Table LXVIII). Solution annealed 1350F - 4 hr. WQ + 1225F - 2 hr WQ, aged 900F - 96 hr. isometric X500, radial face X250.

YS (ksi):	143 (L)	RA (%):	52 (L)	K _Q (ksi/√):	123 (LR)
	147 (T)		19 (T)		76 (SL)

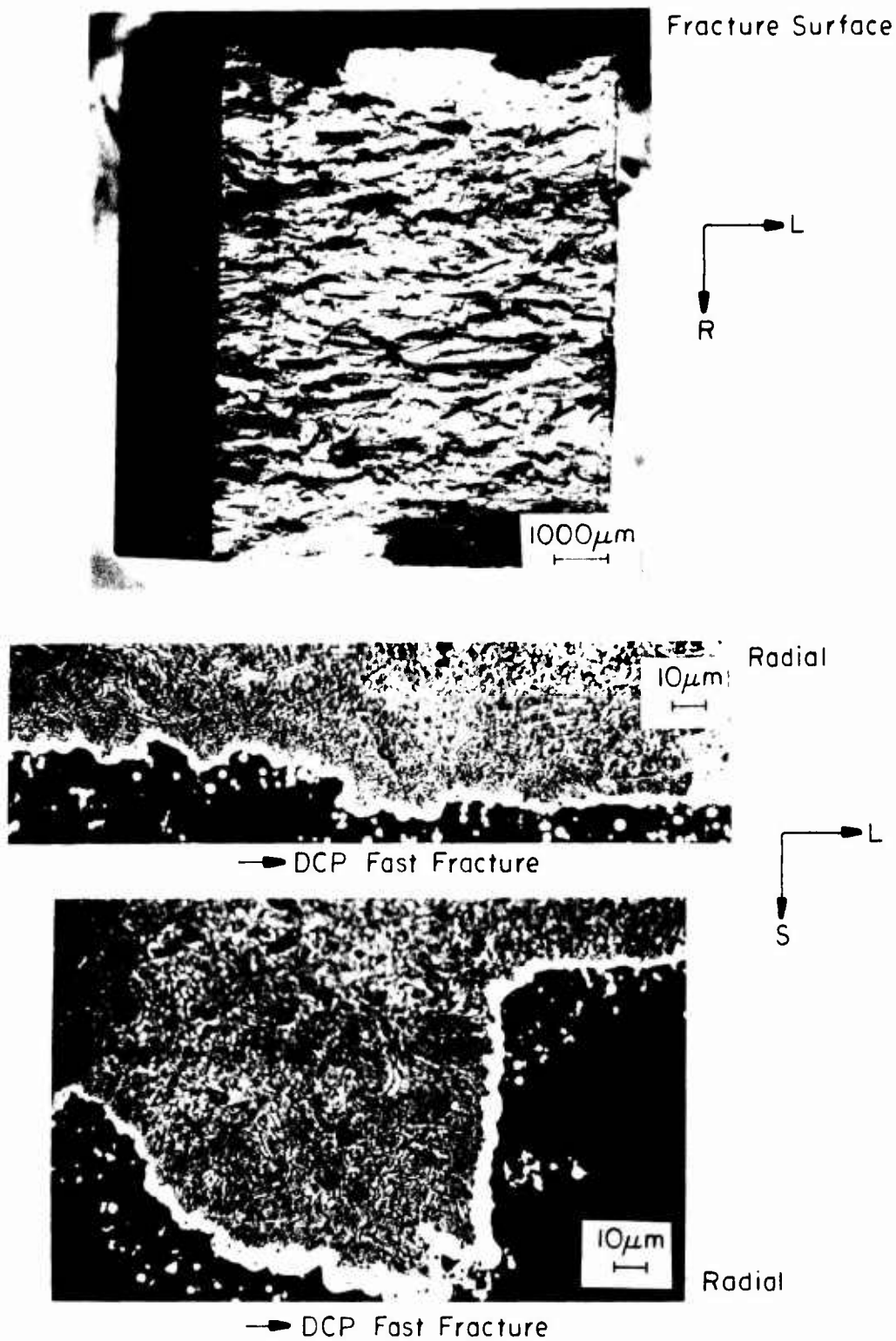

Figure 193. Alloy 253, sample 3SLC2. Fracture surface X8, crack path (top) X500 close to transition, (bottom) X500 distant from transition.

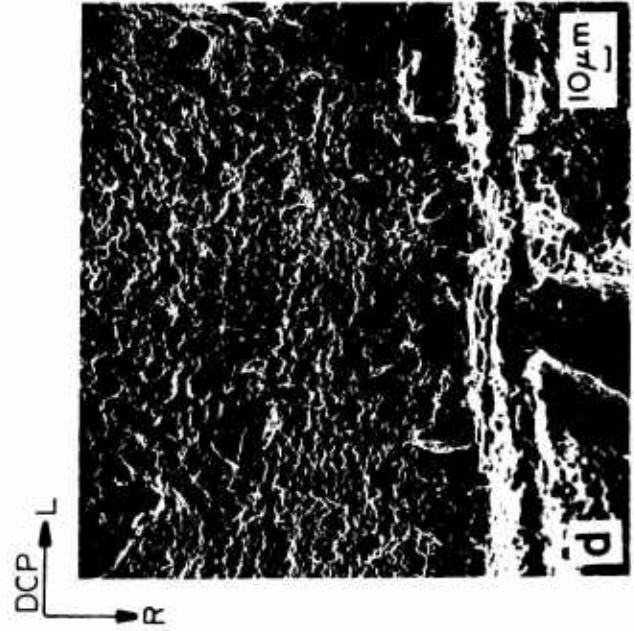

Figure 194. Alloy 253, sample 3SLC2. SEM of fracture surface (a) X25, (b) X250 - precrack/fast fracture transition, (c) X1000 - fast fracture close to transition, (d) X300 - fast fracture.

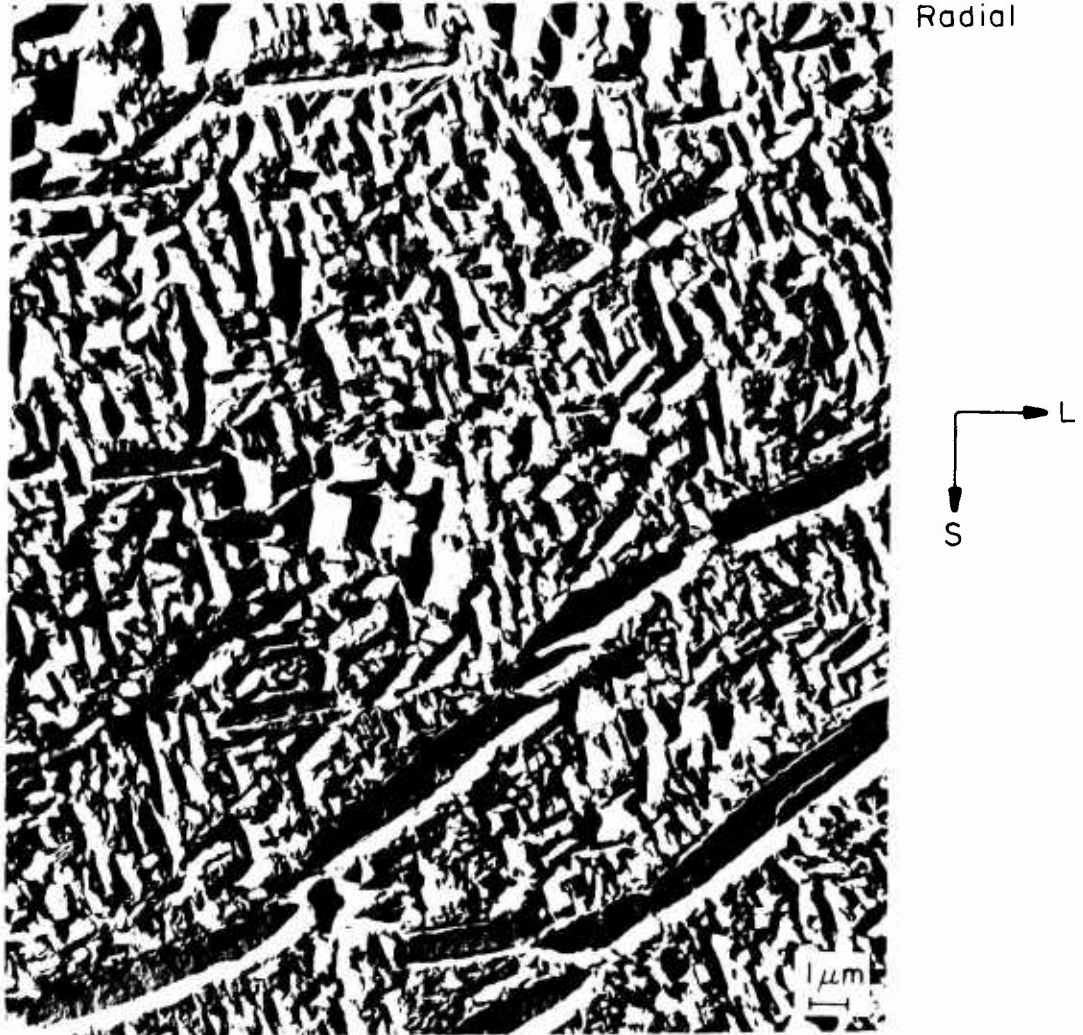

Figure 195. Alloy 253, sample 3SLC2. Surface replica X5200.

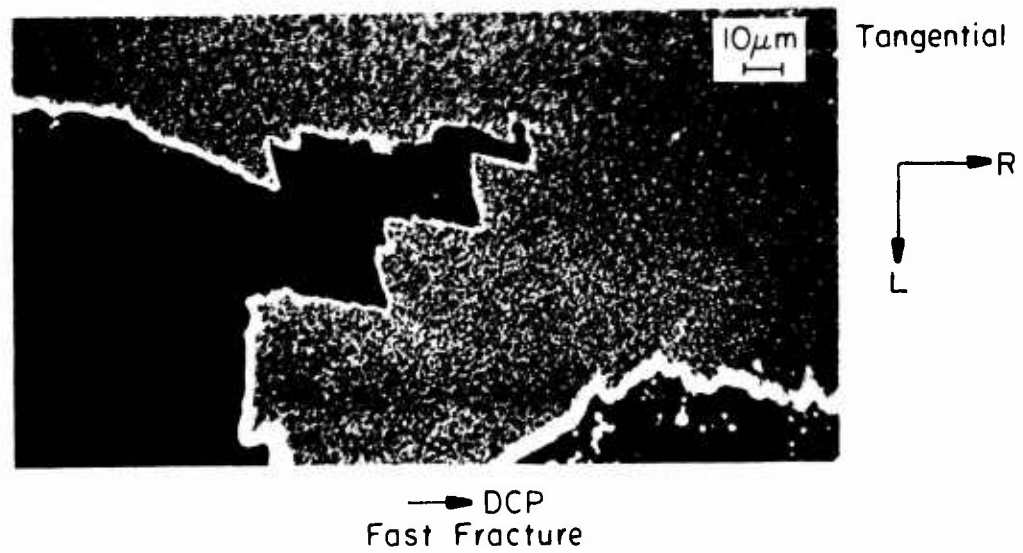
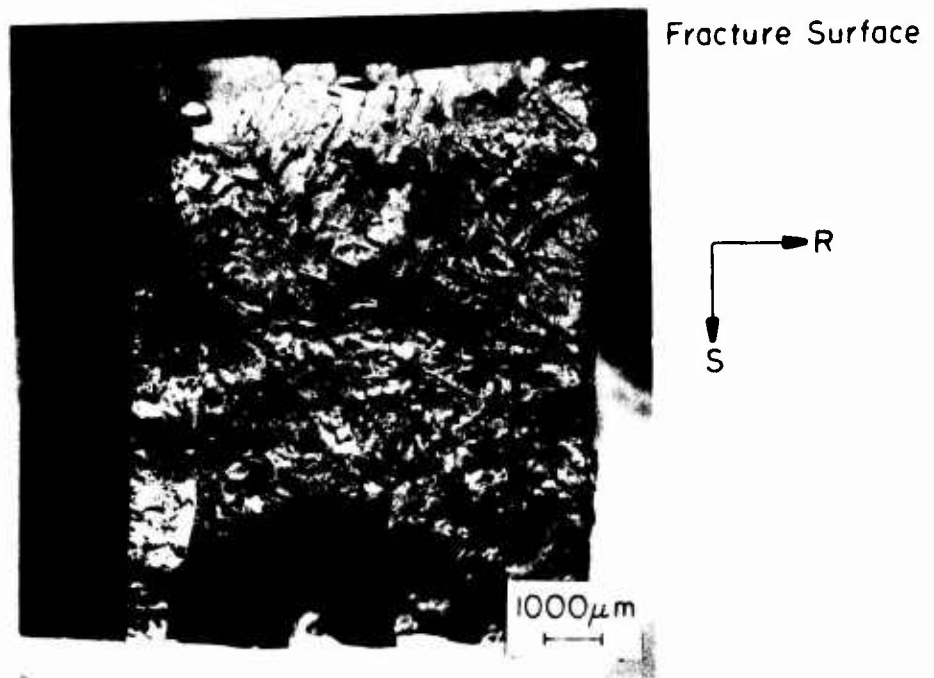

Figure 196. Alloy 253, sample 3LRC1. Fracture surface X8, crack path X500. Note path deviation.

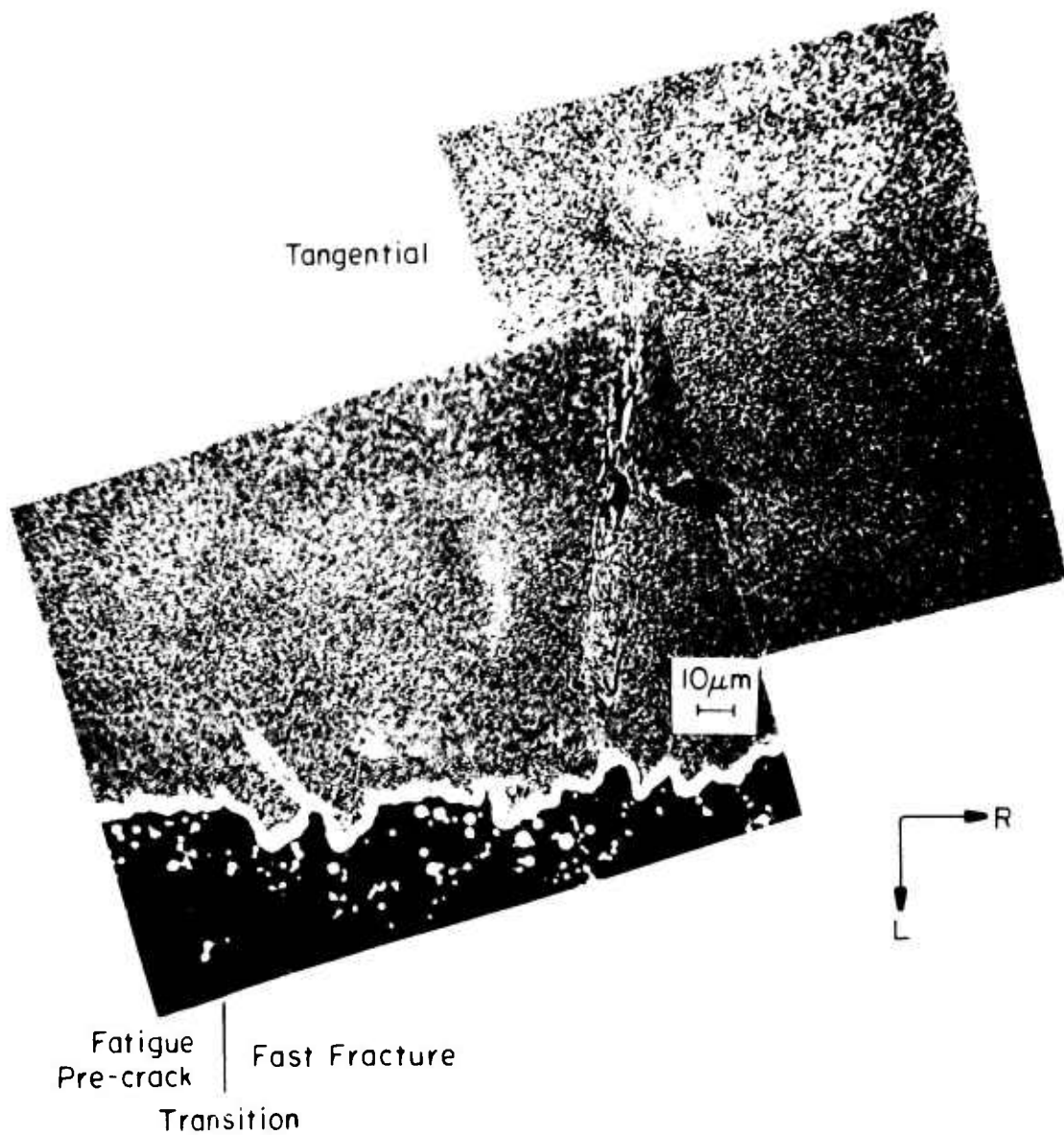

Figure 197. Alloy 253, sample 3LRC1. Crack path X500.

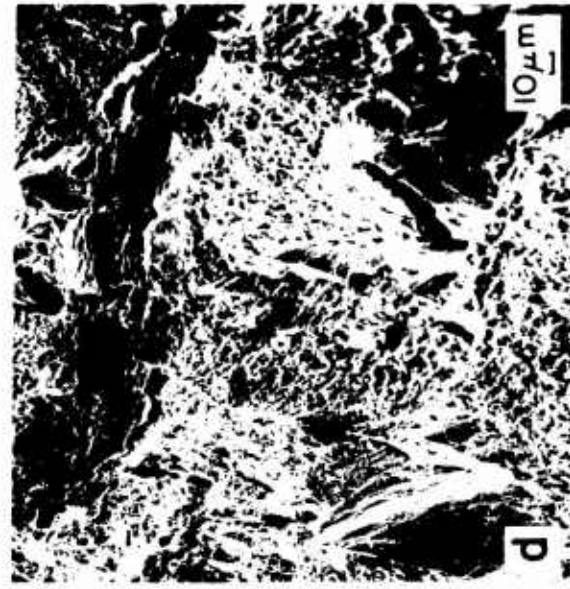
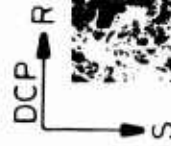

Figure 198 .Alloy 253, sample 3LRC1. SEM of fracture surface (a) X25, (b) X250 - precrack/fast fracture transition, (c) X500 - fast fracture close to transition, (d) X250 - fast fracture.



Tangential

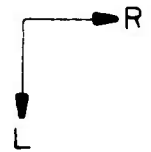

Figure 199 . Alloy 253, sample 3LRC1. Surface replica. X5200

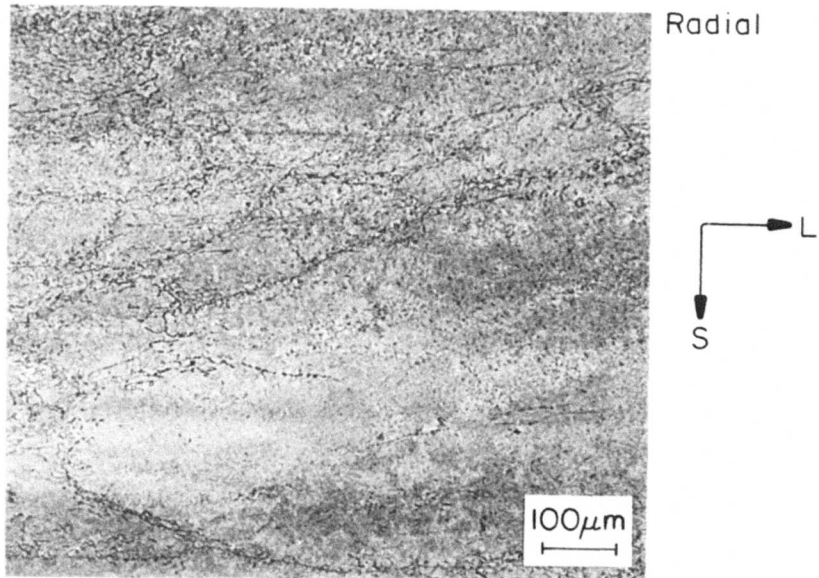
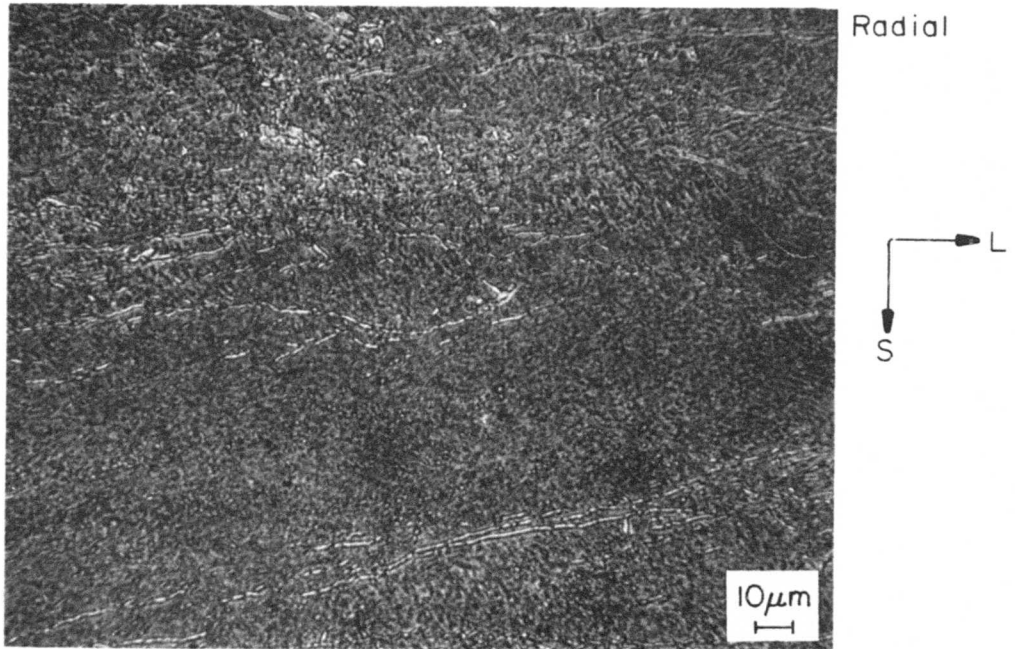

Figure 200. Alloy 253(10Mo-6Cr-2.5Al). Six inch billet full piece, edge samples 3SLE2 and 3LRE2 (Table LXVIII). Solution annealed 1350F - 4 hr WQ plus 1225F-2 hr WQ, aged 900F-96 hr. Radial face X500 (top), X100 (bottom).

YS(ksi):	150 (L)	RA(%):	51 (L)	K _Q (ksi/in):	137 (LR)
	147 (T)		18 (T)		81 (SL)

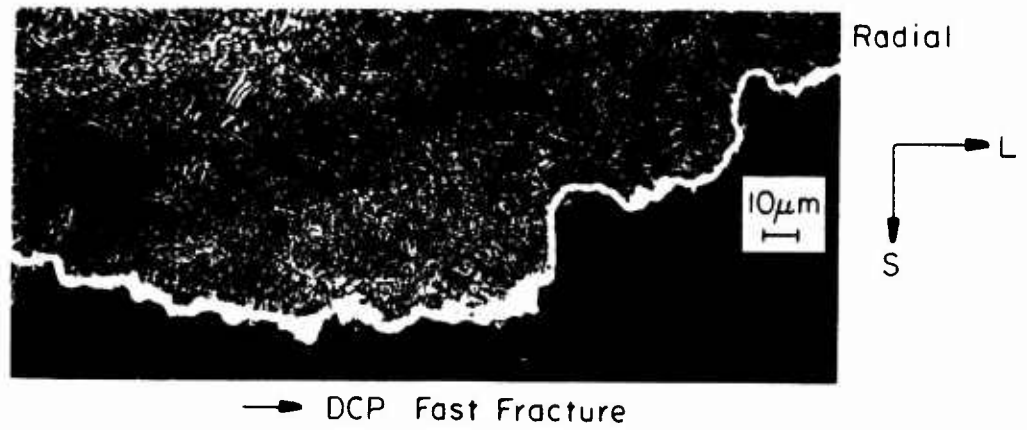
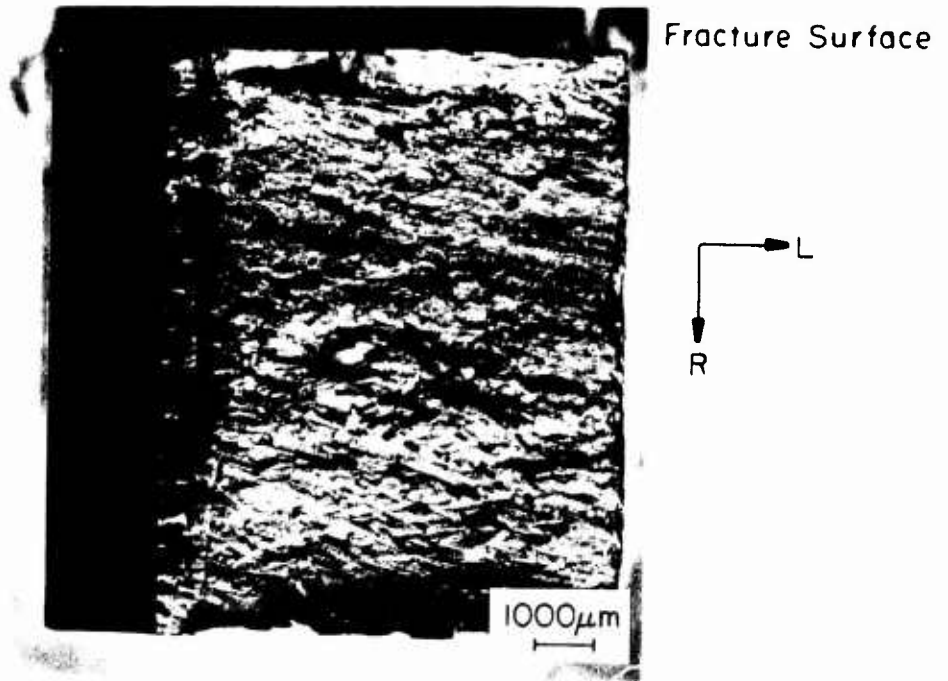

Figure 201. Alloy 253, sample 3SLE2. Fracture surface X8, crack path X500.

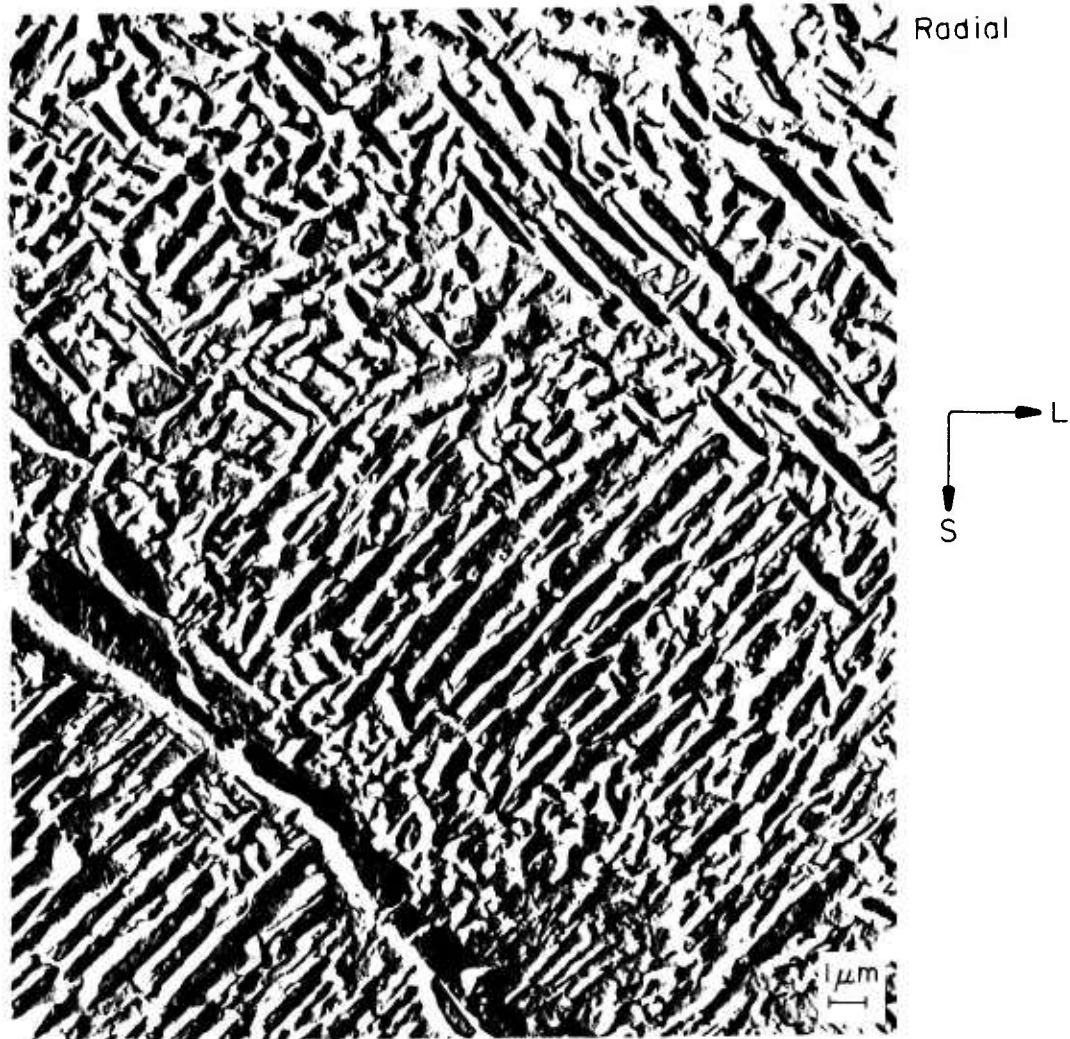
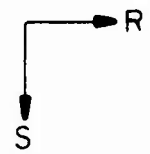

Figure 202. Alloy 253, sample 3SLE2. Surface replica X5200.



Fracture Surface



Tangential

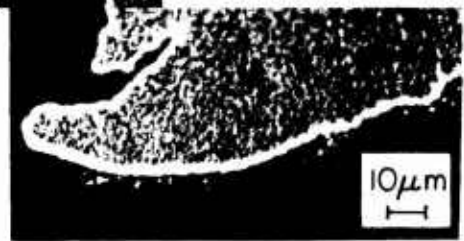
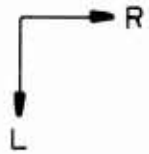

Fatigue Pre-crack

Fast Fracture

→ DCP

Figure 203. Alloy 253, sample 3LRE2. Fracture surface X8, crack path X500.

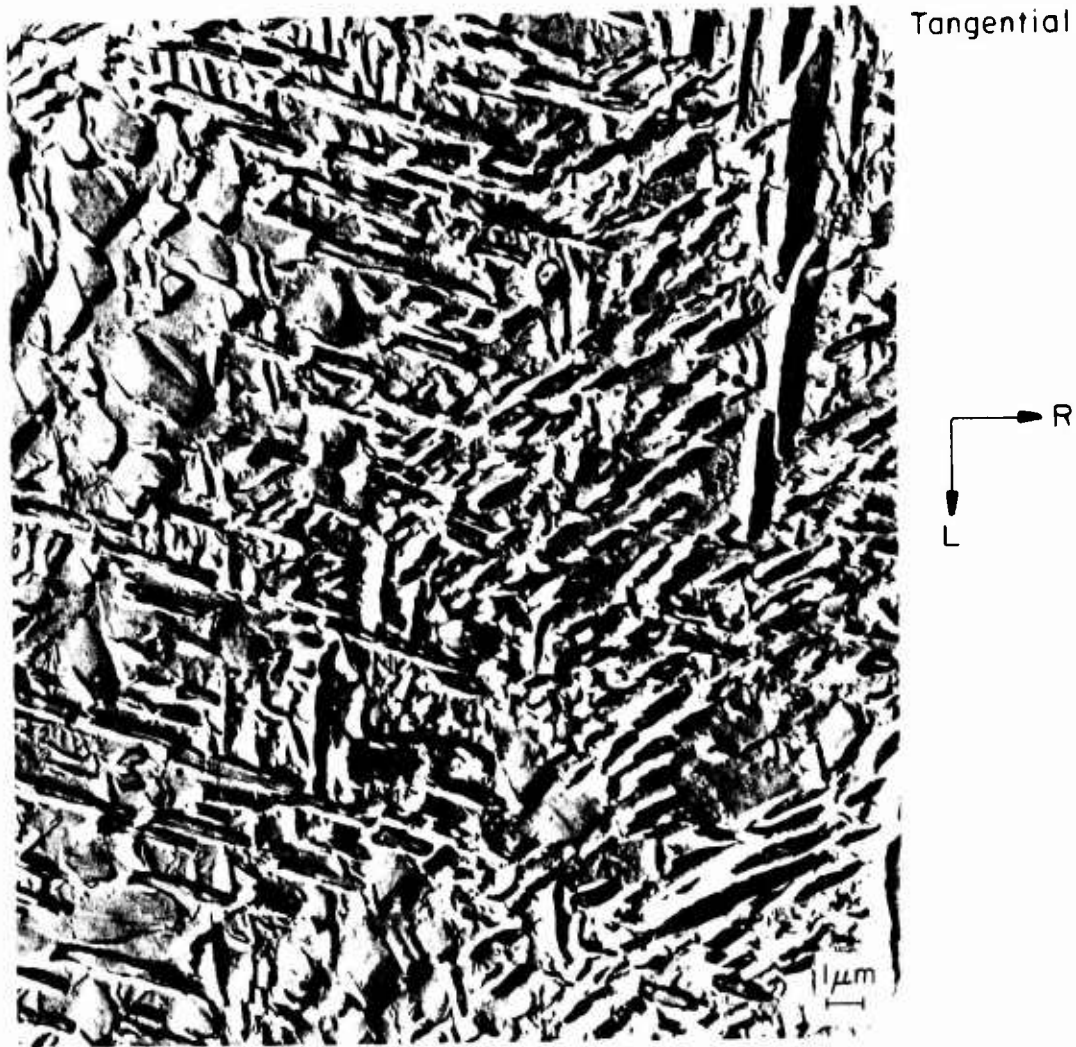

Figure 204. Alloy 253, sample 3LRE2. Surface replica X5200.

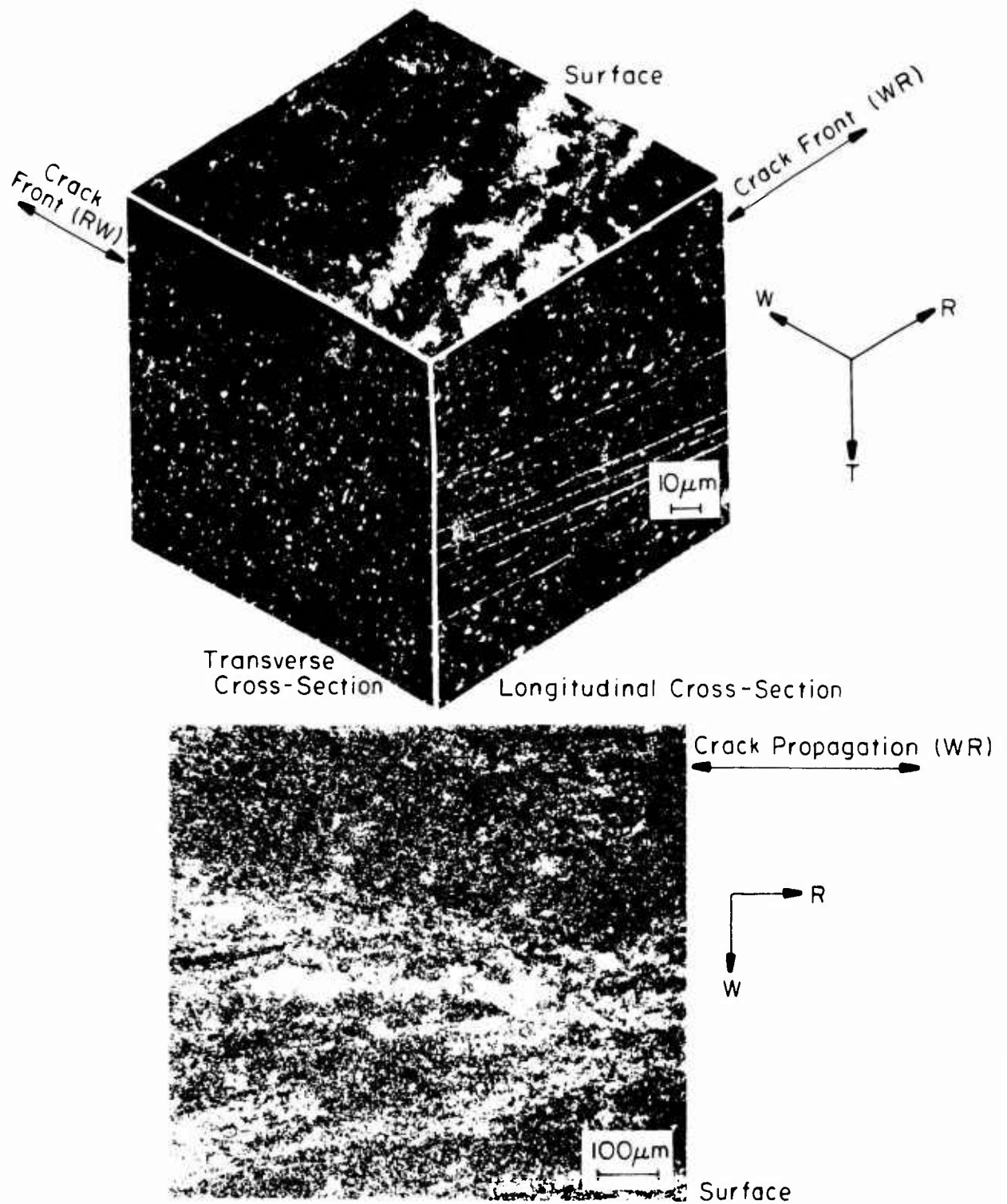

Figure 205. Alloy 334(10Mo-6Cr-2.5Al). Half inch plate, sample 4WRH1 (Table LXXVII). Solution annealed 1350F-8 hr WQ, aged 1025F-96 hr. Isometric X500, surface face X100.

YS(ksi):	159 (L)	RA(%):	36 (L)	K _Q (ksi/in):	65 (RW)
	171 (T)		9 (T)		60 (WR)

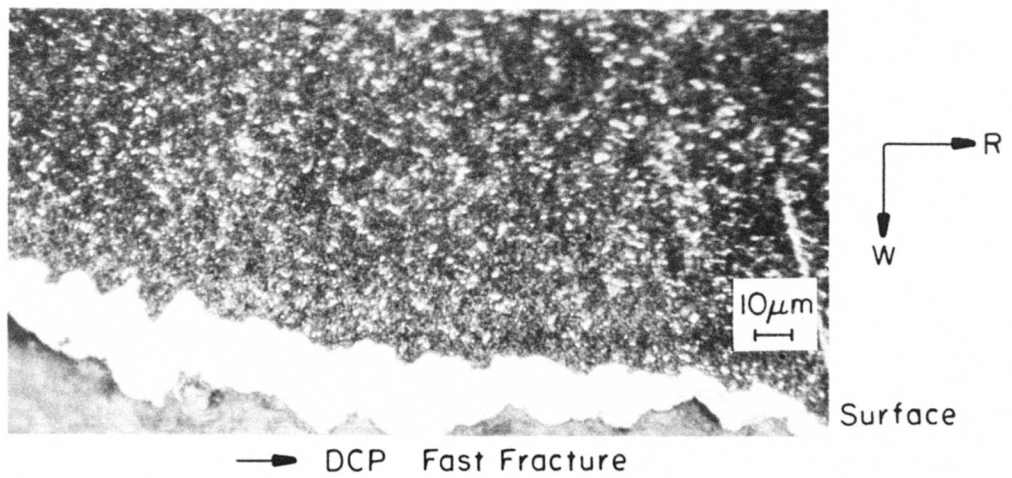
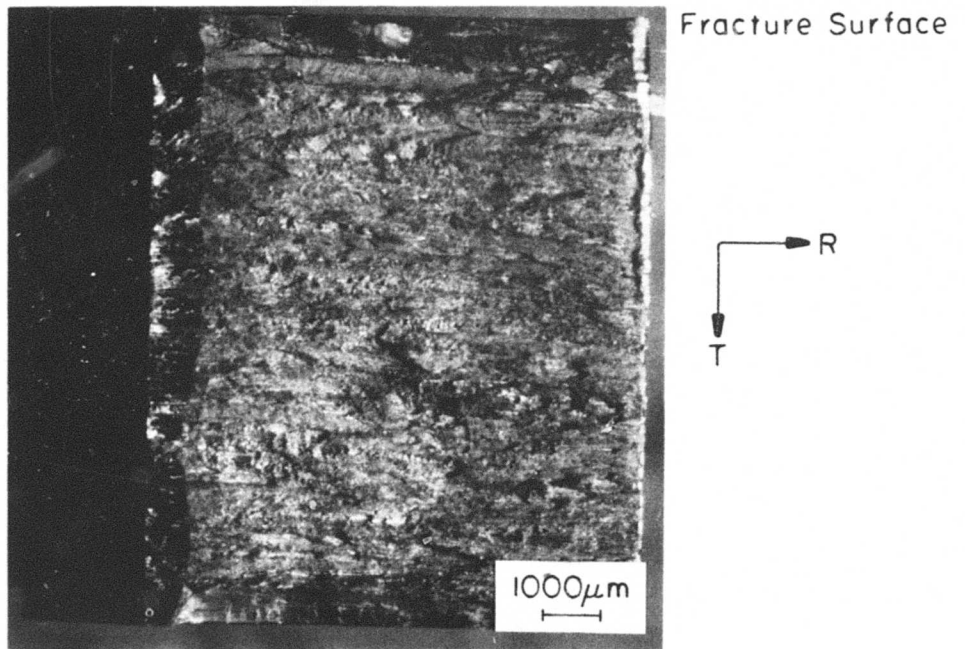

Figure 206. Alloy 334, sample 4WRH1. Fracture surface X8, crack path X500.

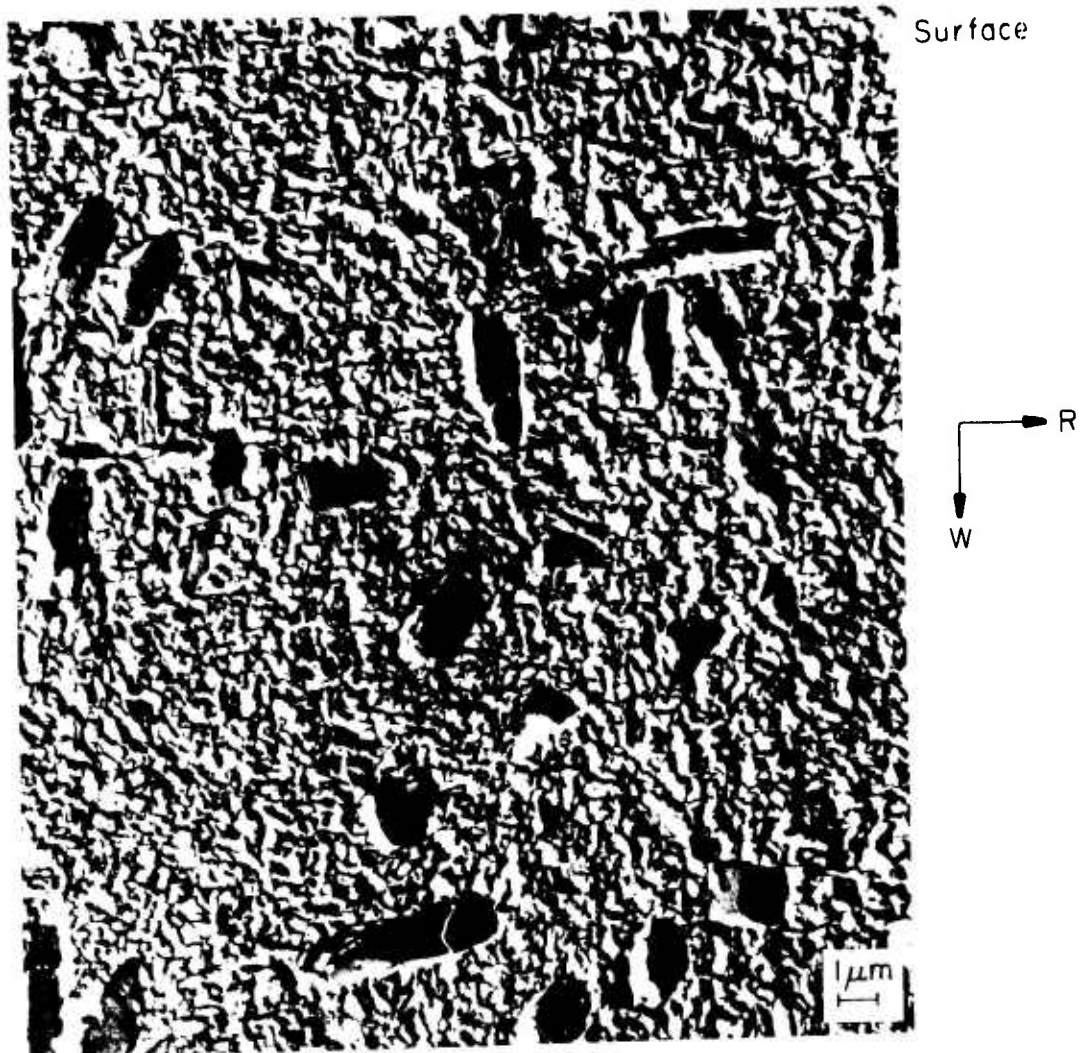

Figure 207. Alloy 334, sample 4WRH1. Surface replica X5200.

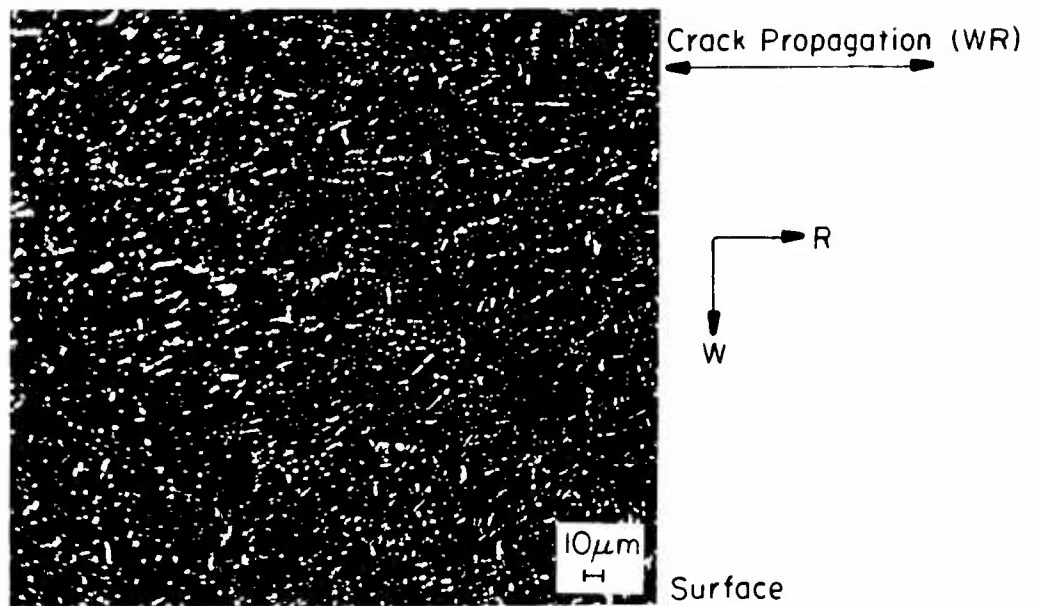
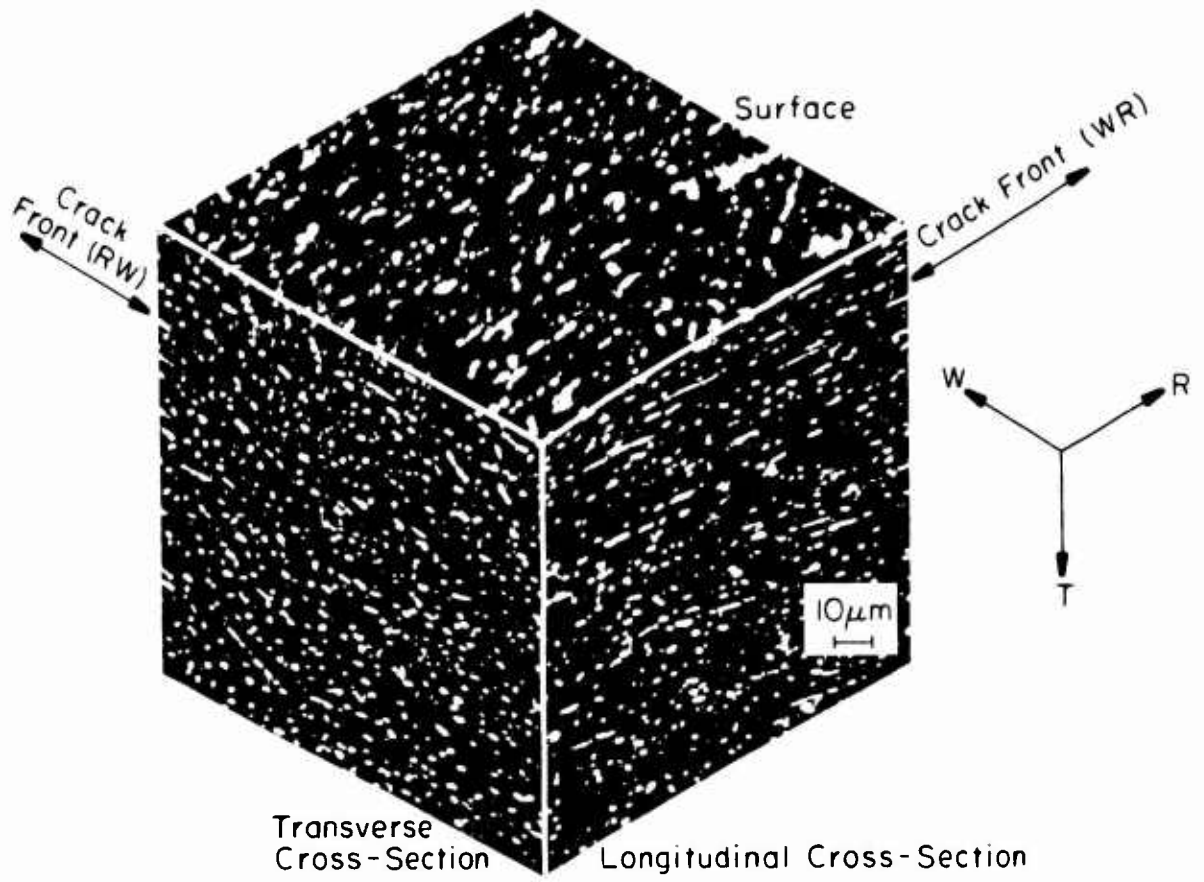

Figure 208 . Alloy 227(7Mo-4Cr-2.5Al). Half inch plate, sample 7WRL2 (Table LXVII). Solution annealed 1450F-8 hr WQ, aged 1025F-8 hr. Isometric X500, surface face X250.

YS(ksi):	164 (L)	RA(%):	47 (L)	KQ(ksi/in):	48 (RW)
	178 (T)		32 (T)		43 (WR)

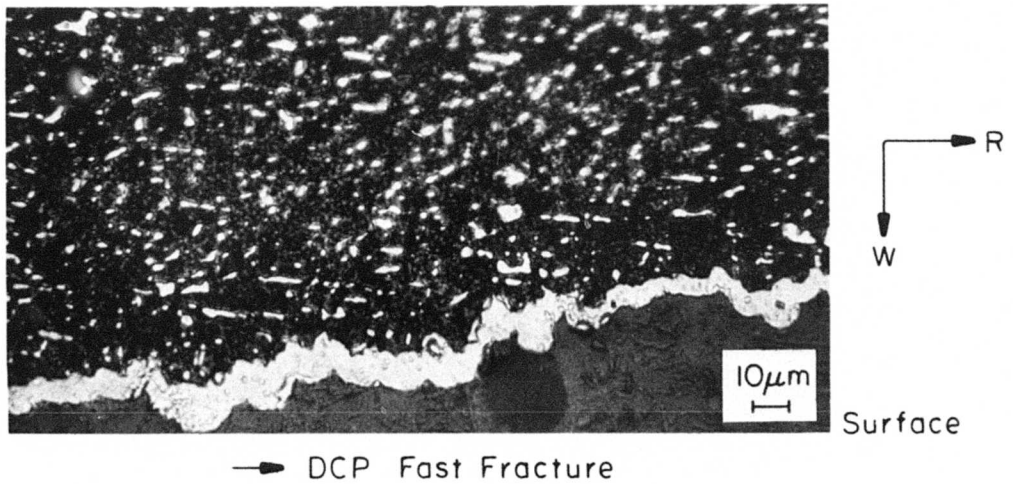
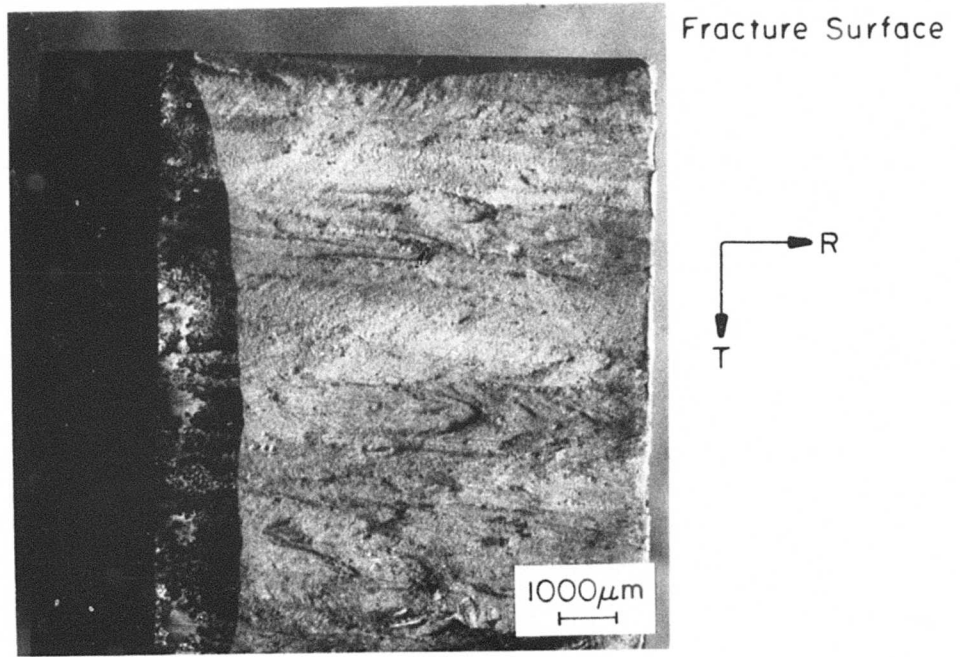

Figure 209. Alloy 227, sample 7WRL2. Fracture surface X8, crack path X500.

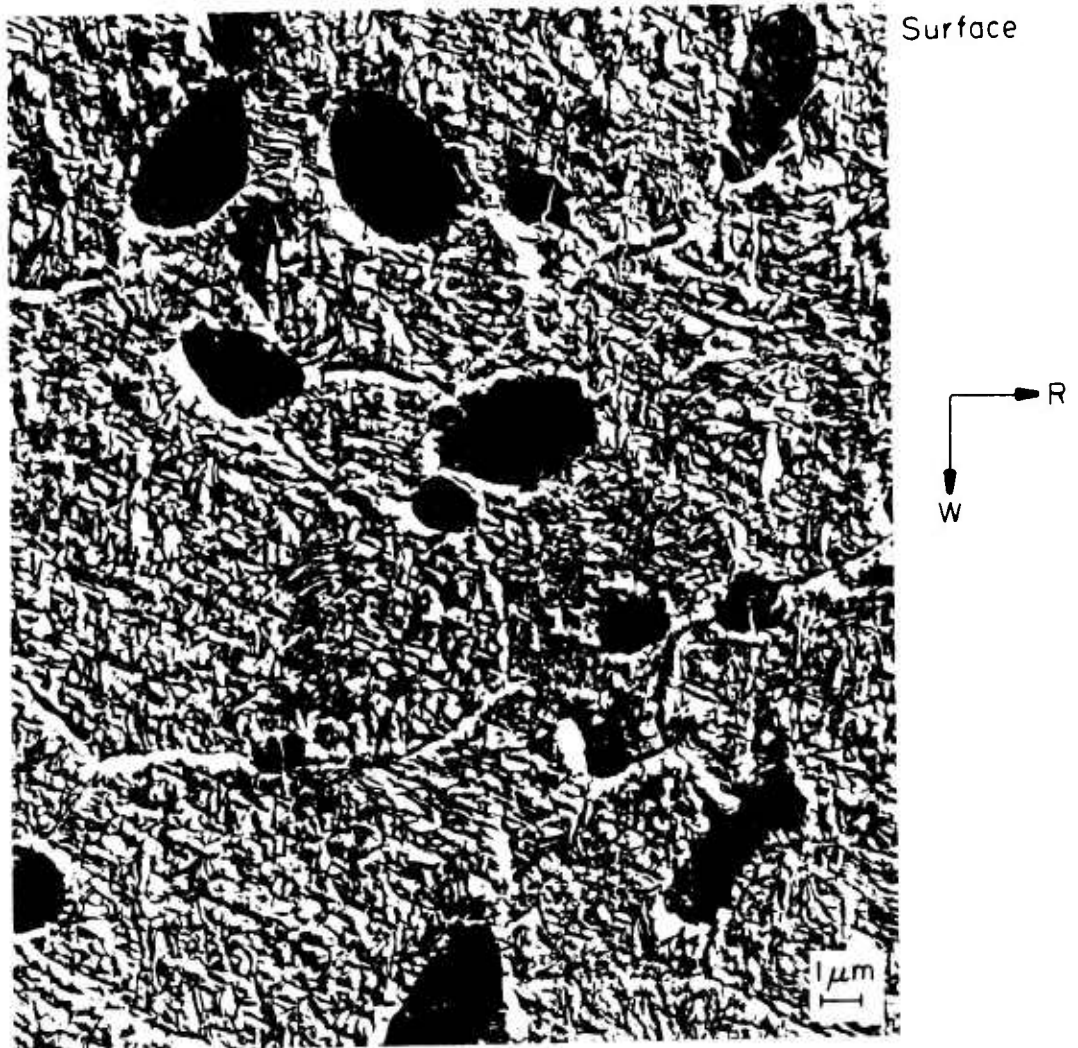

Figure 210. Alloy 227, sample 7WRL2. Surface replica X5200.

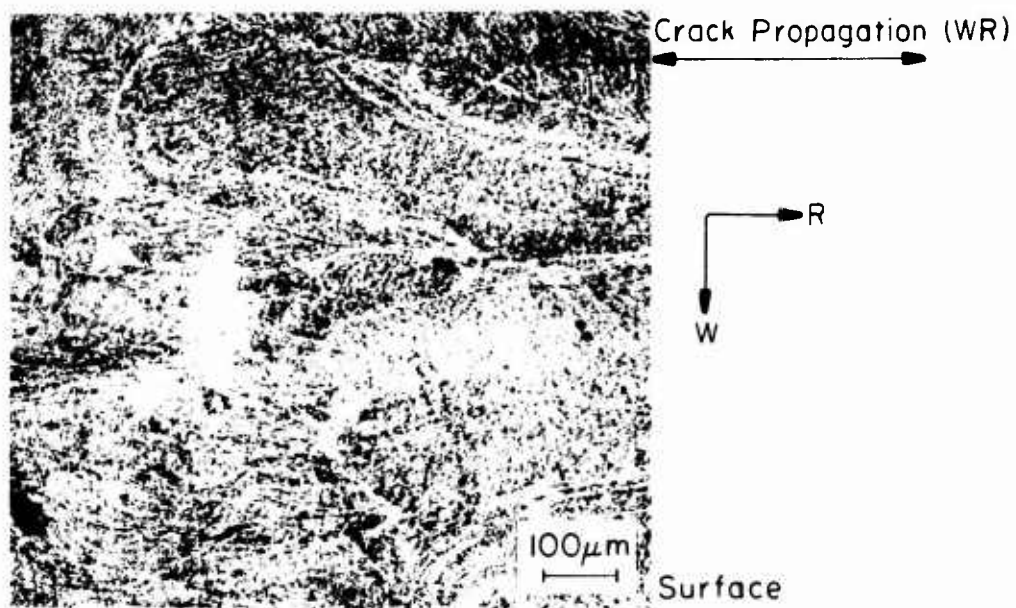
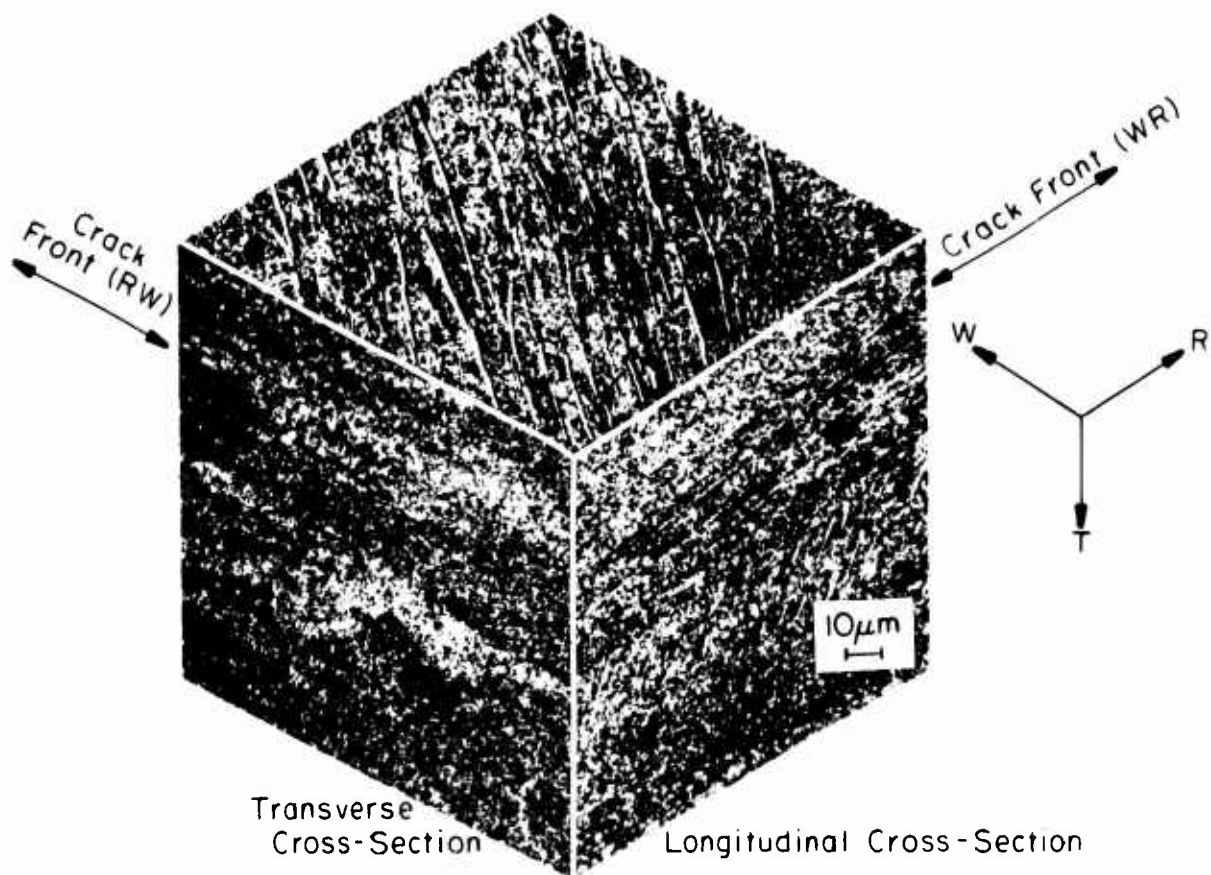

Figure 211. Alloy 253(10Mo-8V-2.5Al). Half inch plate, sample 3WRL2 (Table LXXIX). Solution annealed 1350F-8 hr WQ, aged 950F-96 hr. Isometric X500, surface face X100.

YS(ksi):	170 (L)	RA(%):	6 (L)	K_Q (ksi/in):	49 (RW)
	182 (T)		15 (T)		47 (WR)

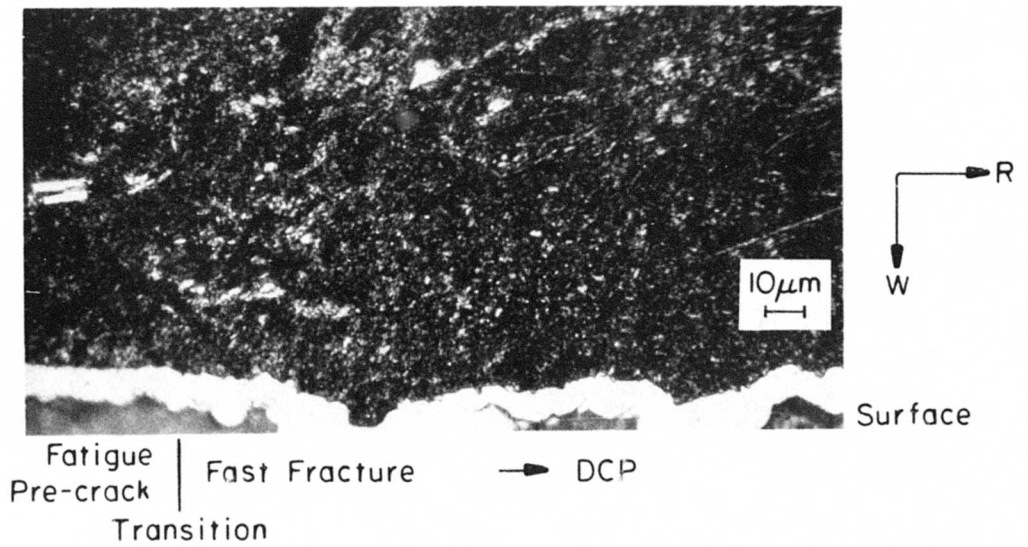
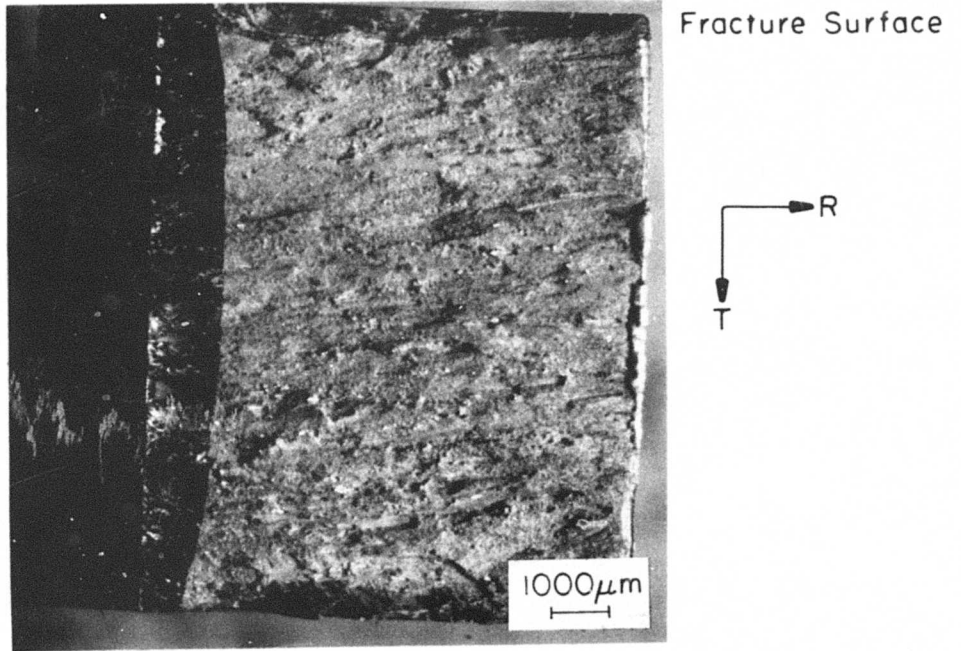

Figure 212. Alloy 253, sample 3WRL2. Fracture surface X8, crack path X500.

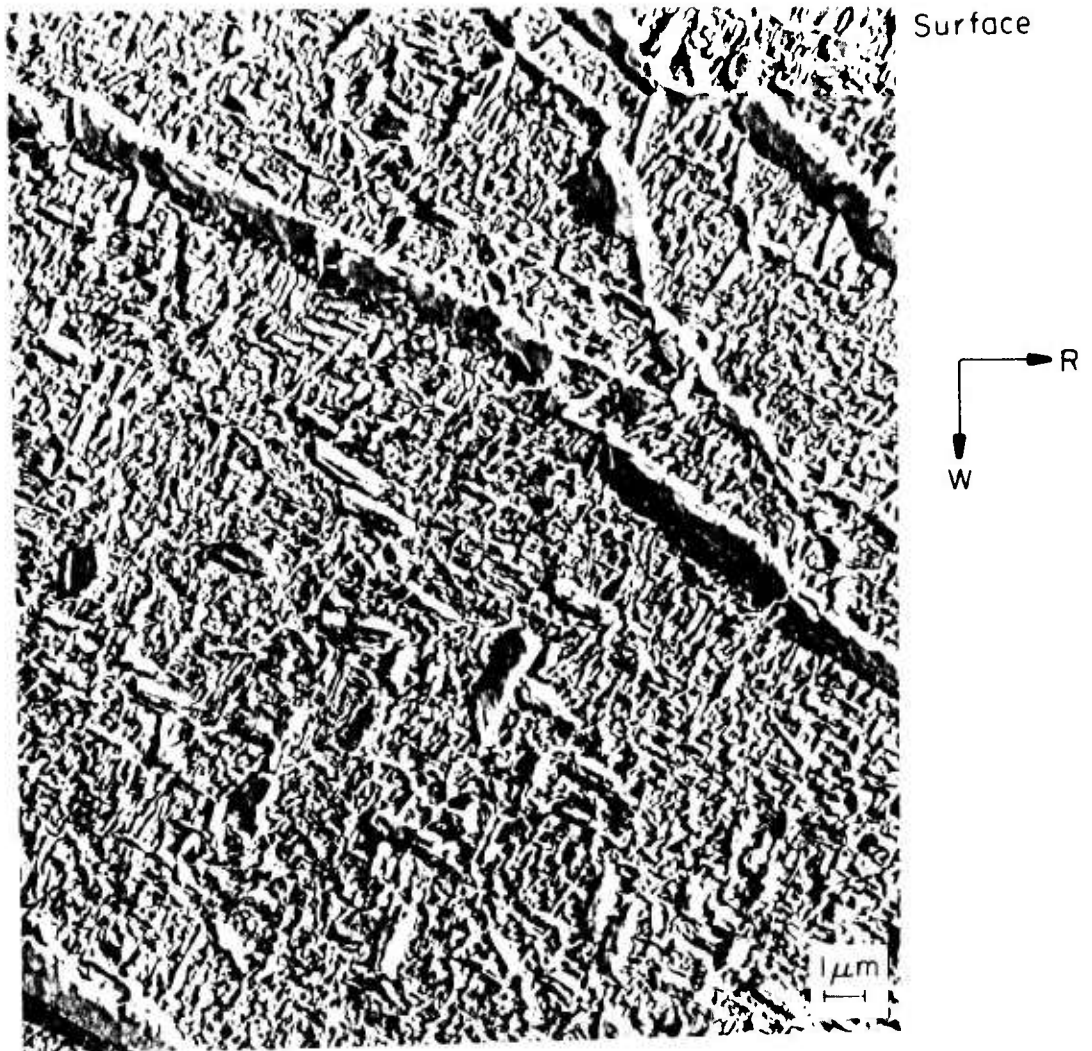

Figure 213. Alloy 253, sample 3WRL2. Surface replica X5200.

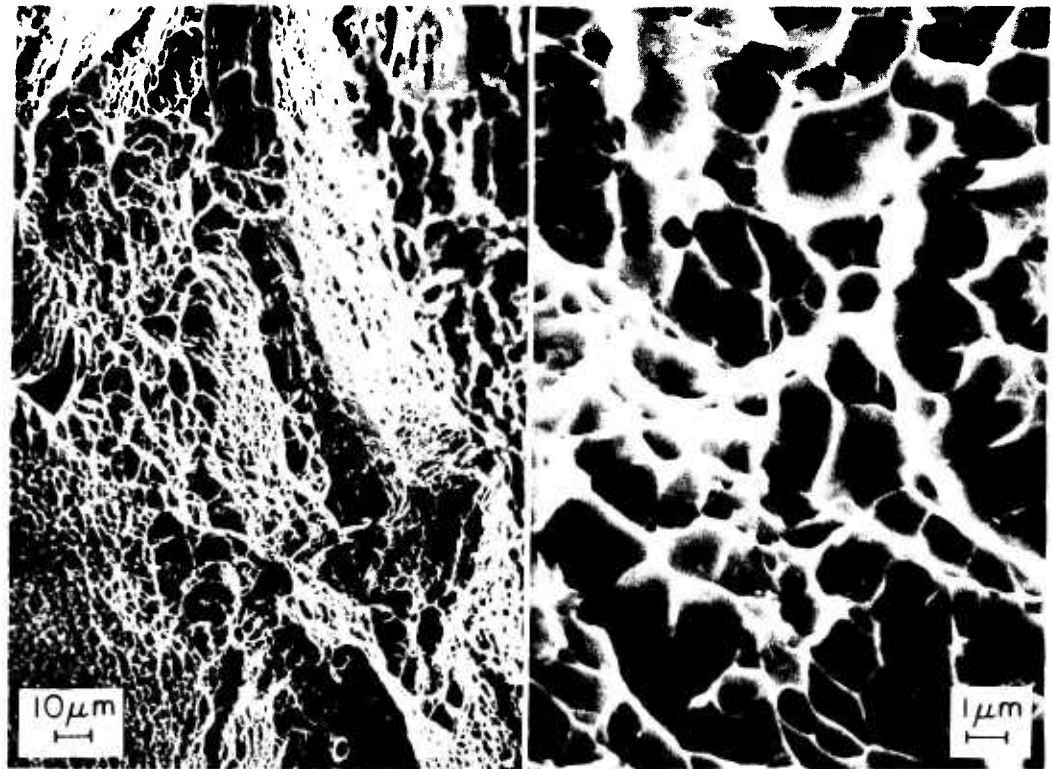
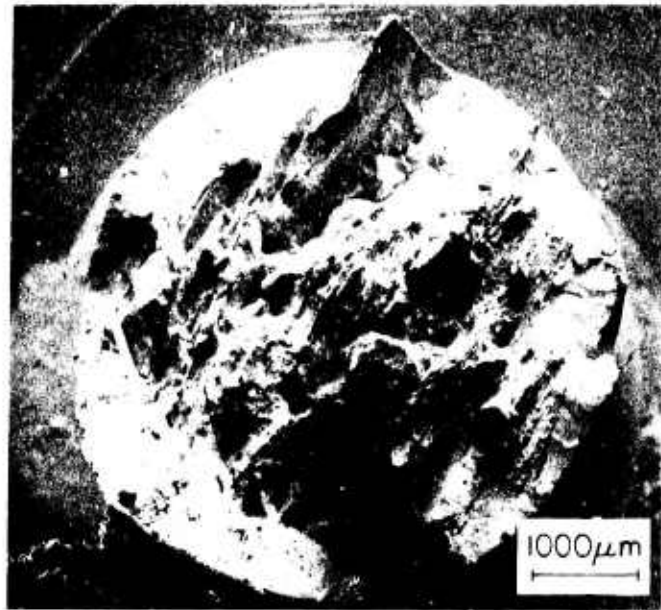

Figure 214. Alloy 334(10Mo-6Cr-2.5Al). Six inch billet full piece center sample 4TC2 (companion sample to 4SLC2, Figure 103, see Table LXVI). Solution annealed 1350F-4 hr WQ plus 1225F-2 hr WQ, aged 900F-96 hr. Fractured sample (top) X15, SEM (left) X375, (right) X5200.

YS(ksi):	147 (L)	RA(%):	50 (L)
	151 (T)		33 (T)

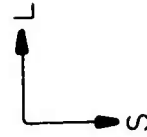
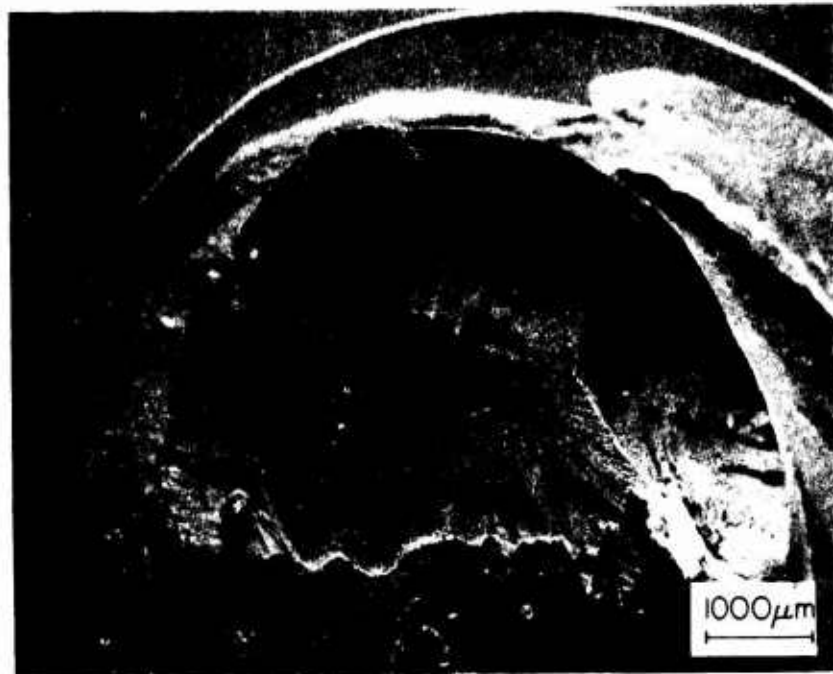
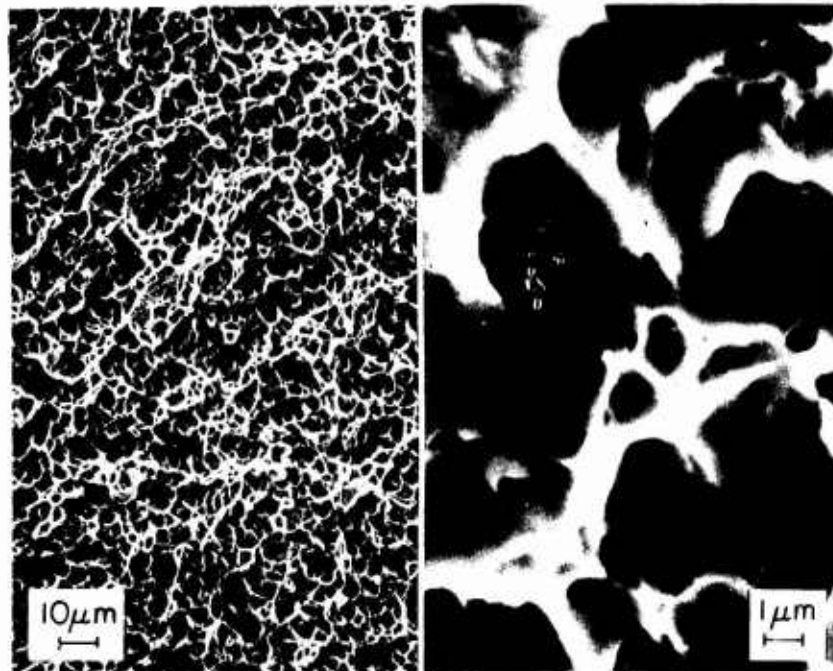

Figure 215. Alloy 334, sample 4TC2. Sectioned tensile sample X500. Note transgranular fracture mode.



LR Face



LR Face

Figure 216. Alloy 227(7Mo-4Cr-2.5Al). Six inch billet slice, sample 7ET3 (companion sample to 7ESR3, Figure 110 Table XLVIII). Solution annealed 1475F-2 hr WQ, aged 1025F-8 hr. Fractured sample (top) X15, SEM X500 (left), X5200 (right).

YS(ksi):	174 (L)	RA(%):	24 (L)
	171 (T)		12 (T)



Figure 217. Alloy 227, sample 7ET3. Sectioned tensile sample X500. Note transgranular fracture mode.

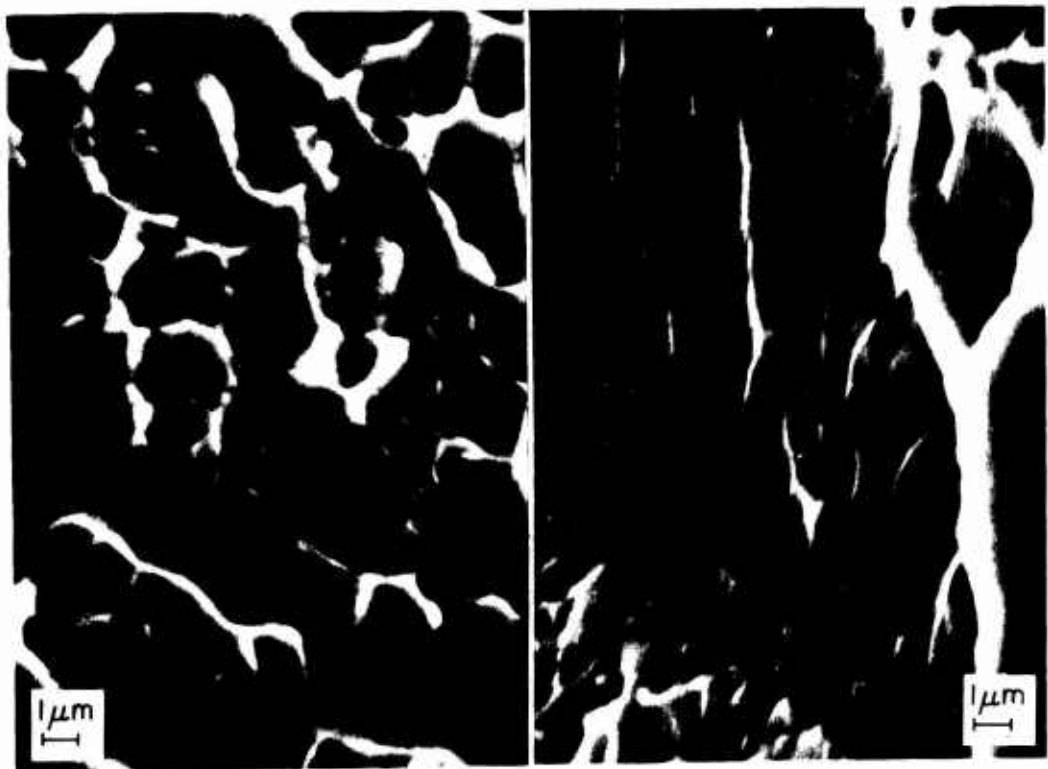
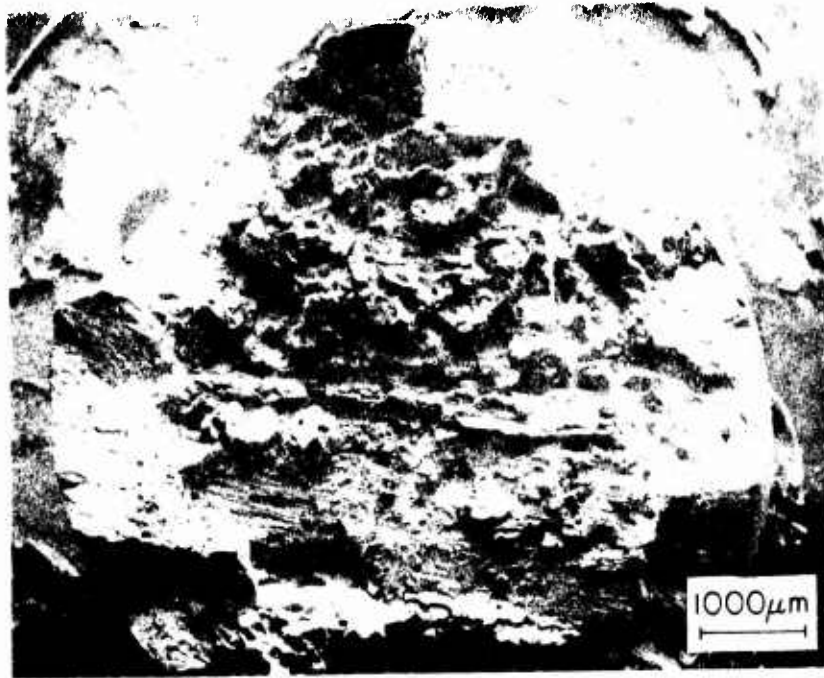

Figure 218. Alloy 227(7Mo-4Cr-2.5Al). Six inch billet slice, sample 7MT7.(Companion sample to 7MSL4, Figure 134 Table LIV). Recrystallize annealed 1575F-0.5 hr WQ, solution annealed 1475F-2 hr, aged 1025F-8 hr. Fractured sample (top) X15, SEM dimpled area (left), smooth area (right) both X5200.

YS(ksi):	180 (L)	RA(%):	5 (L)
	188 (T)		6 (T)

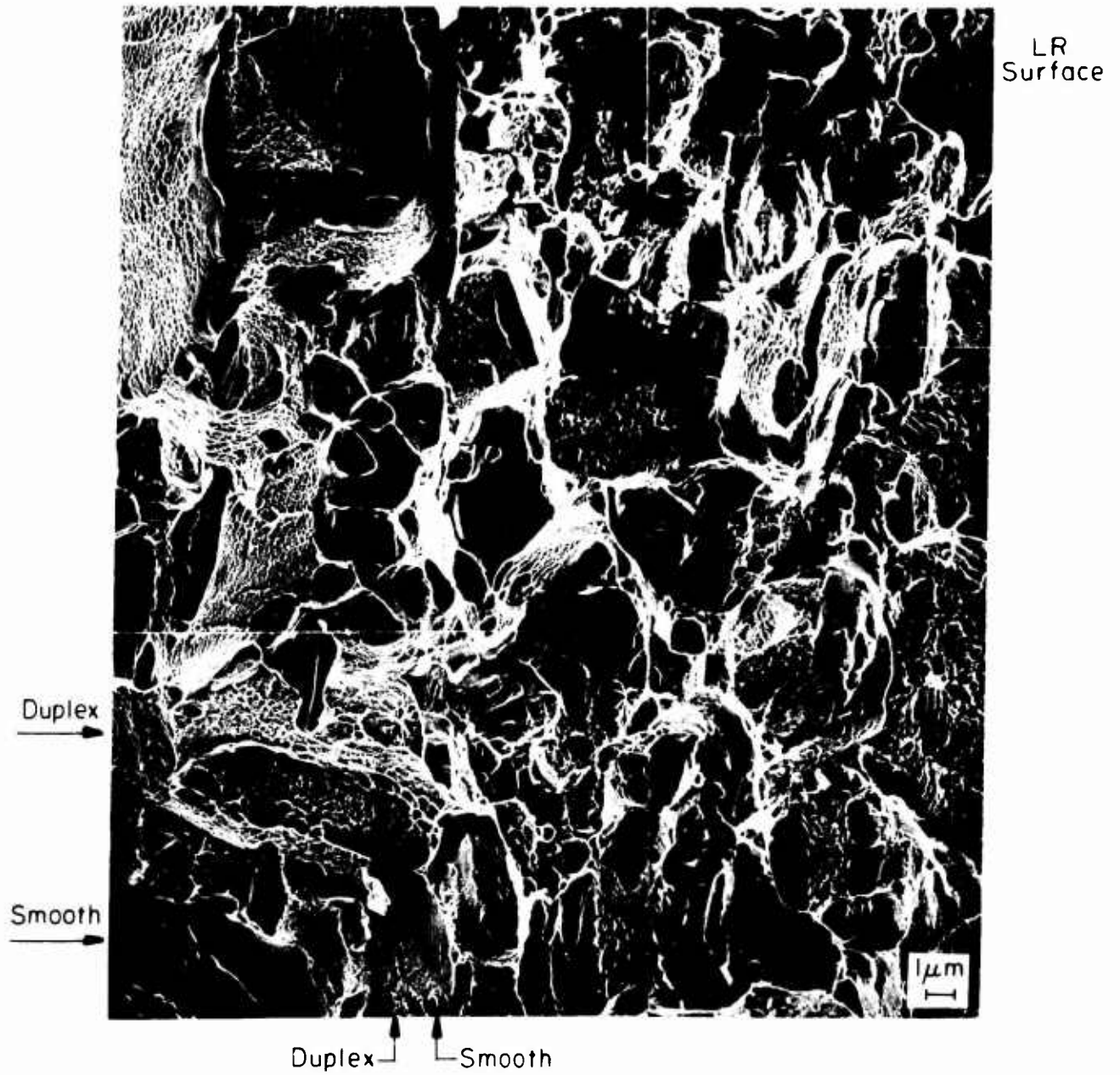

Figure 219. Alloy 227, sample 4MT7. SEM of fracture surface X375. Note indicated dimpled (d) and smooth (S) regions shown at higher magnification in the preceding figure.



Figure 220. Alloy 227, sample 4MT7. Sectioned tensile sample X250. Note intergranular fracture mode.

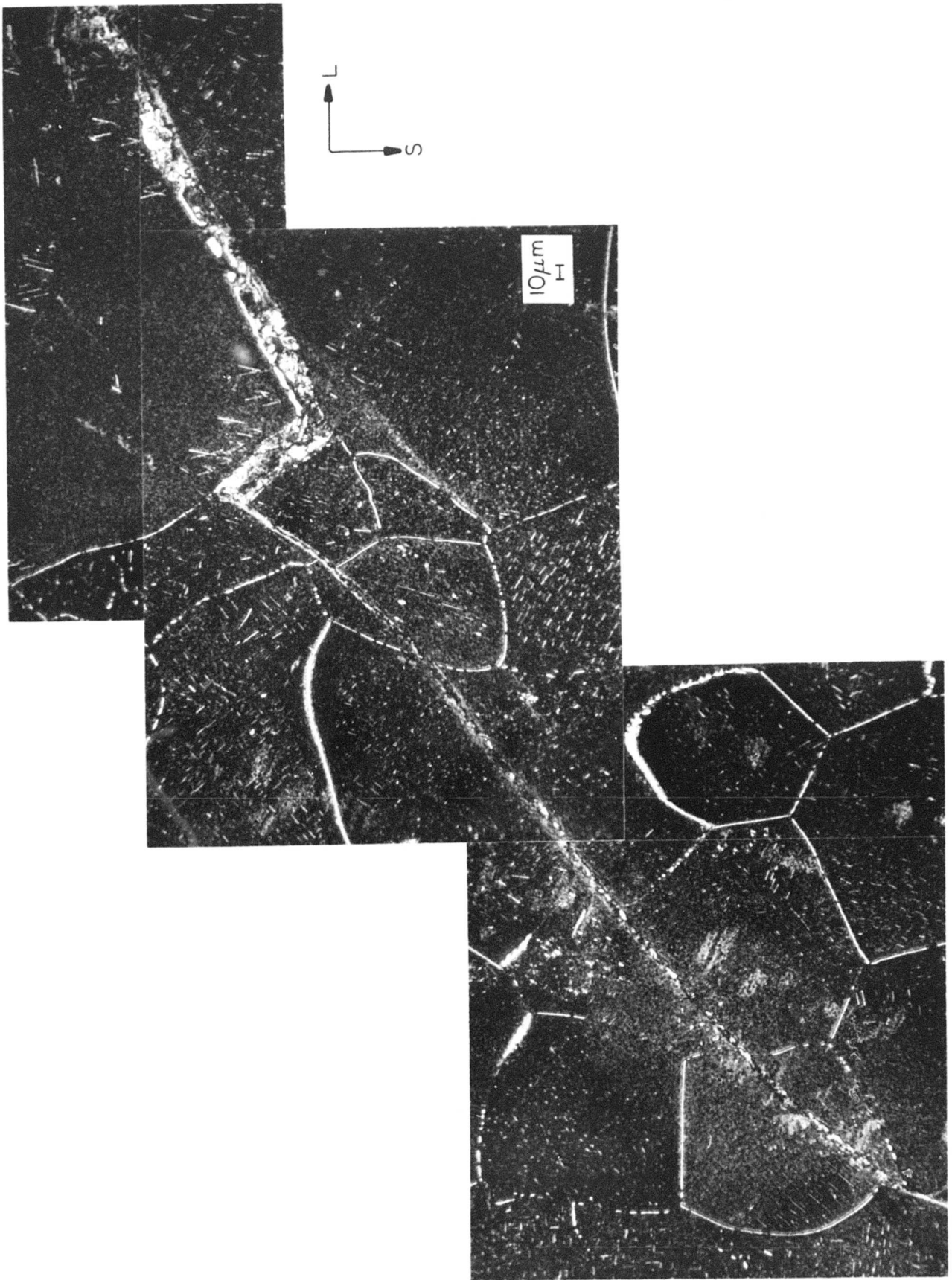
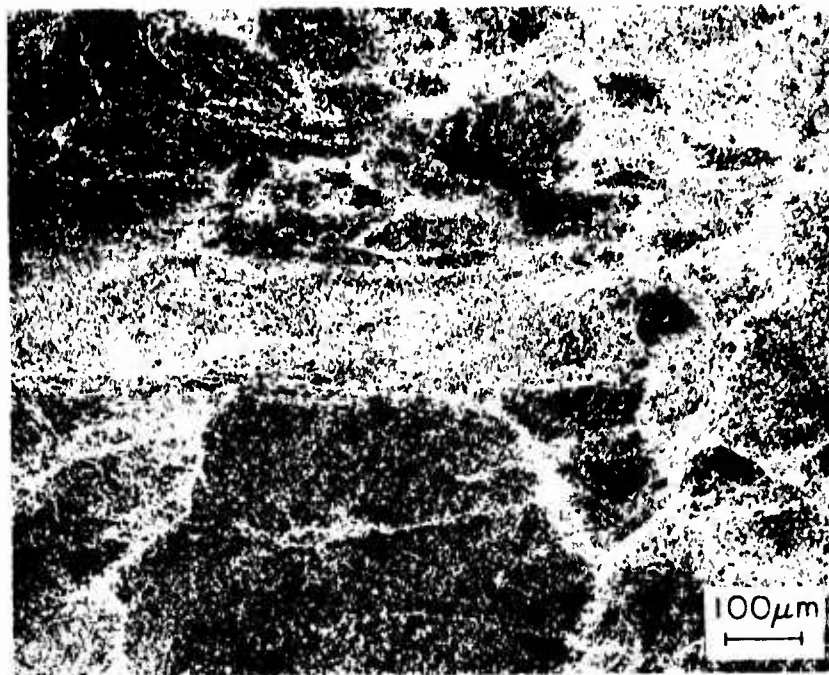
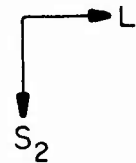
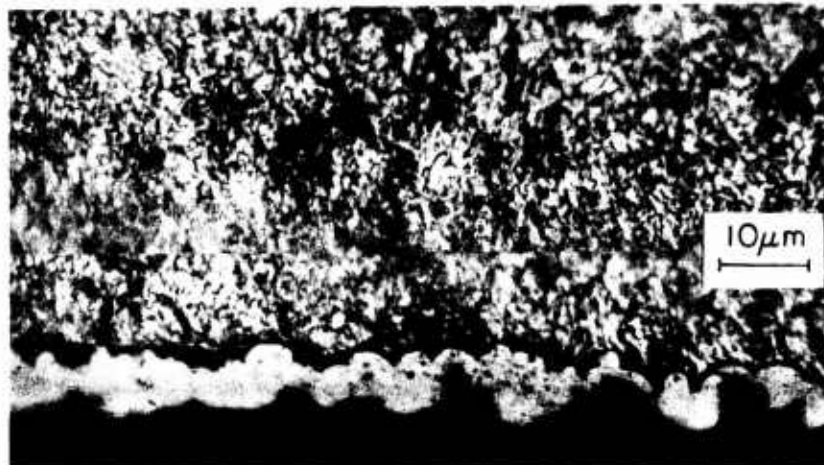

Figure 221. Alloy 227, sample 4MT7. Sectioned tensile sample X250. Side crack exhibiting mixed intergranular/transgranular fracture mode.



Tangential



Tangential

Figure 222. Alloy 334(10Mo-6Cr-2.5Al). Six inch billet full piece, tensile sample 4T4 (Table LXXXI). Duplex solution annealed 1350F-4 hr WQ plus 1225F-2 hr WQ. (Top) X100, (bottom) X1200.

YS(ksi):	129	(L)	RA(%):	52	(L)
	131	(T)		44	(T)

Tangential

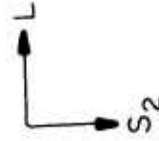
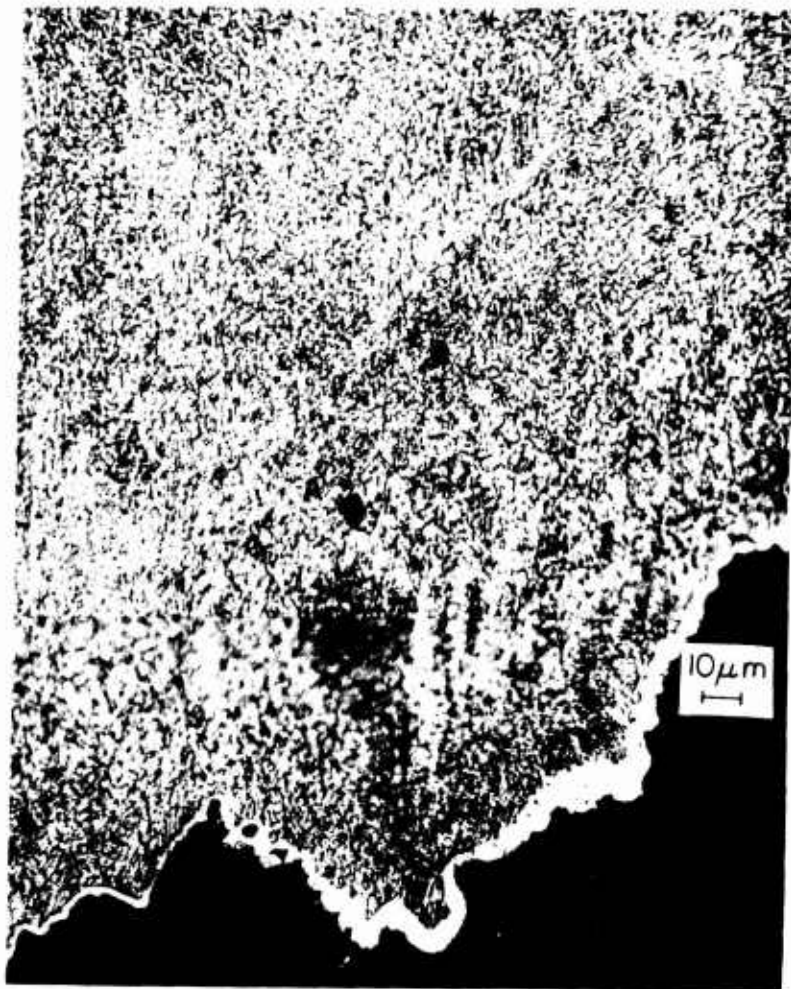
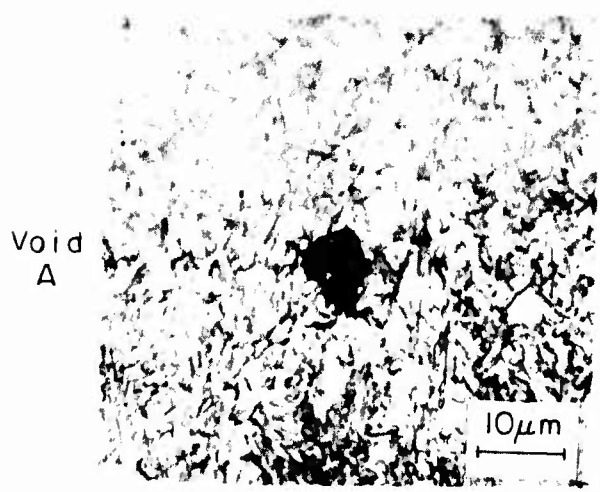
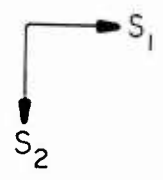

Figure 223. Alloy 334, sample 4T4. Crack path X500.



Axial

10 μ m



Void
A

10 μ m

Figure 224. Alloy 334, sample 4T4. Crack path X500. Higher magnification of void X1200.

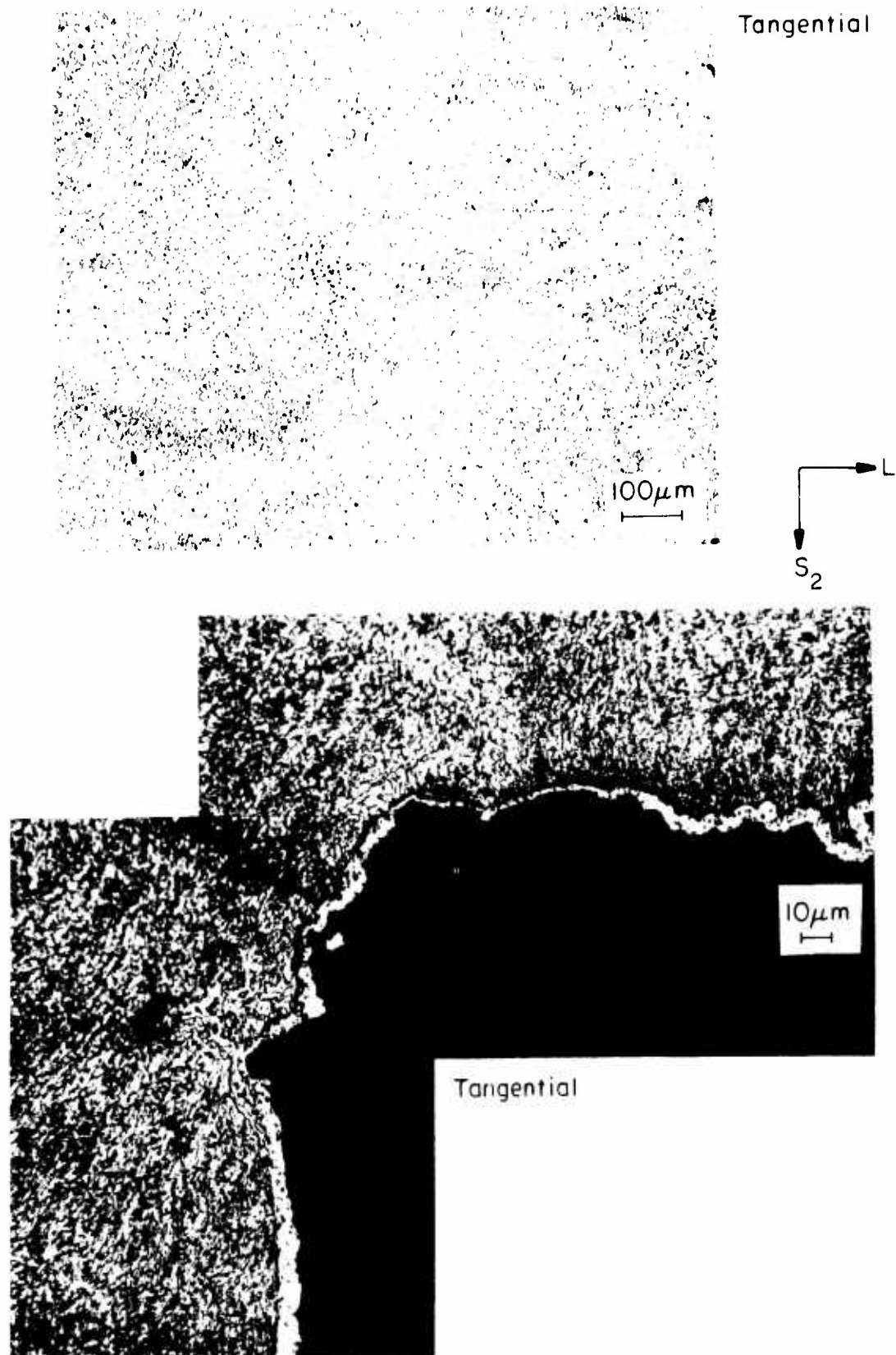

Figure 225. Alloy 227(7Mo-4Cr-2.5Al). Six inch billet full piece, tensile sample 7T2 (Table LXXXI). Duplex solution annealed 1450F-2 hr WQ plus 1350F-8 hr WQ. Tangential face X100, crack path X500.

YS(ksi):	122	(L)	RA(%):	58	(L)
	124	(T)		49	(T)

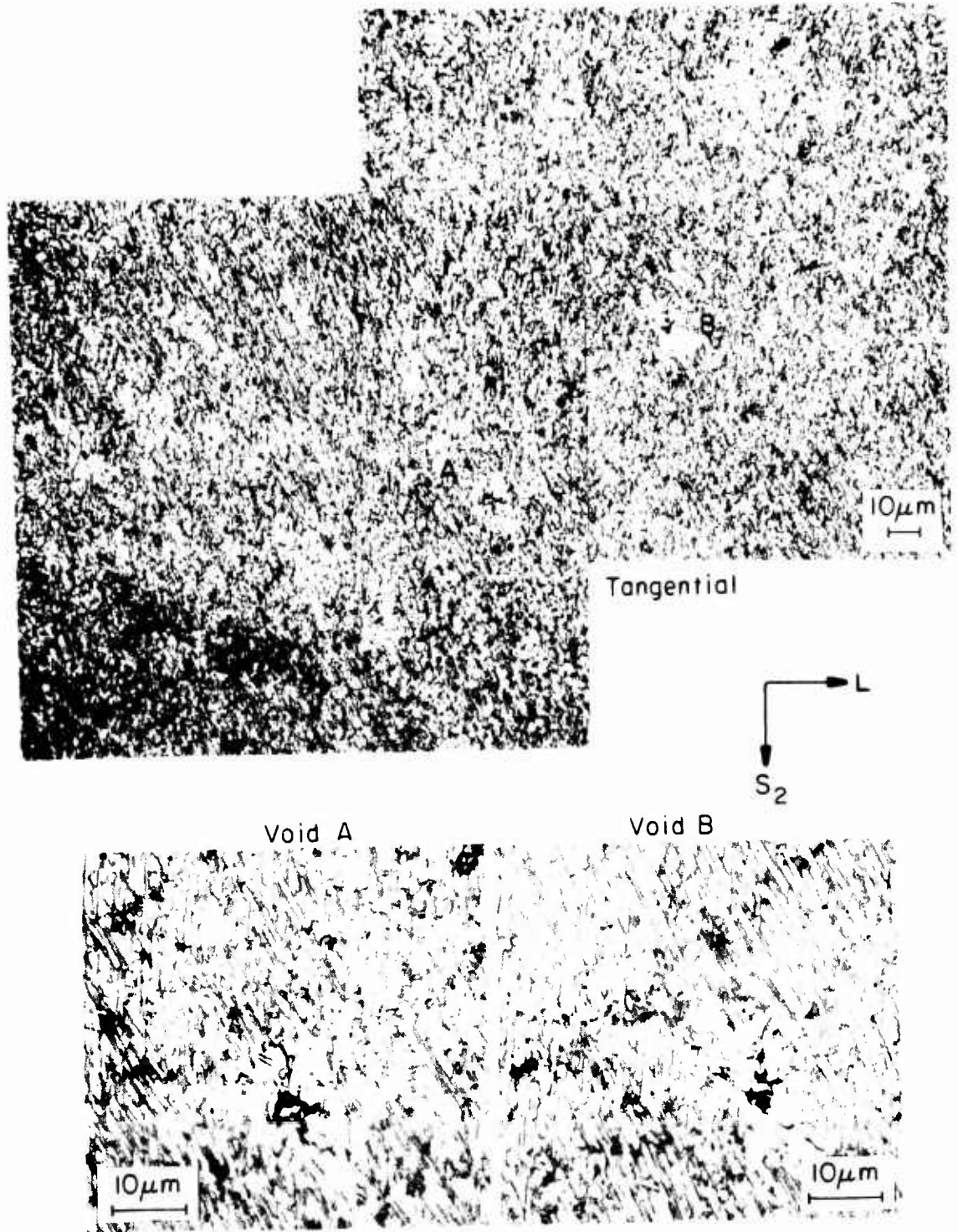

Figure 226. Alloy 227, sample 7T2. Tangential surface just away from fractured surface, note voids indicated. General view X500, higher magnification of voids X1200.

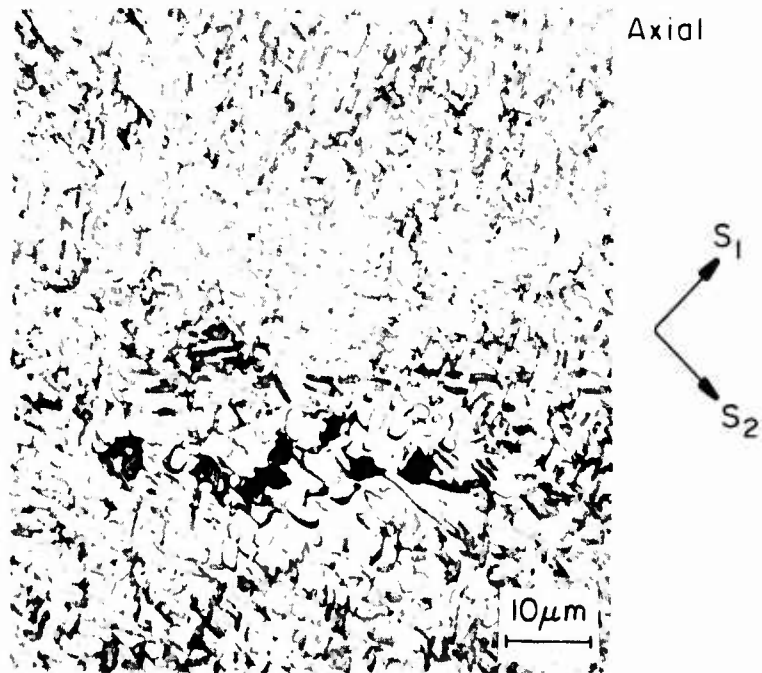
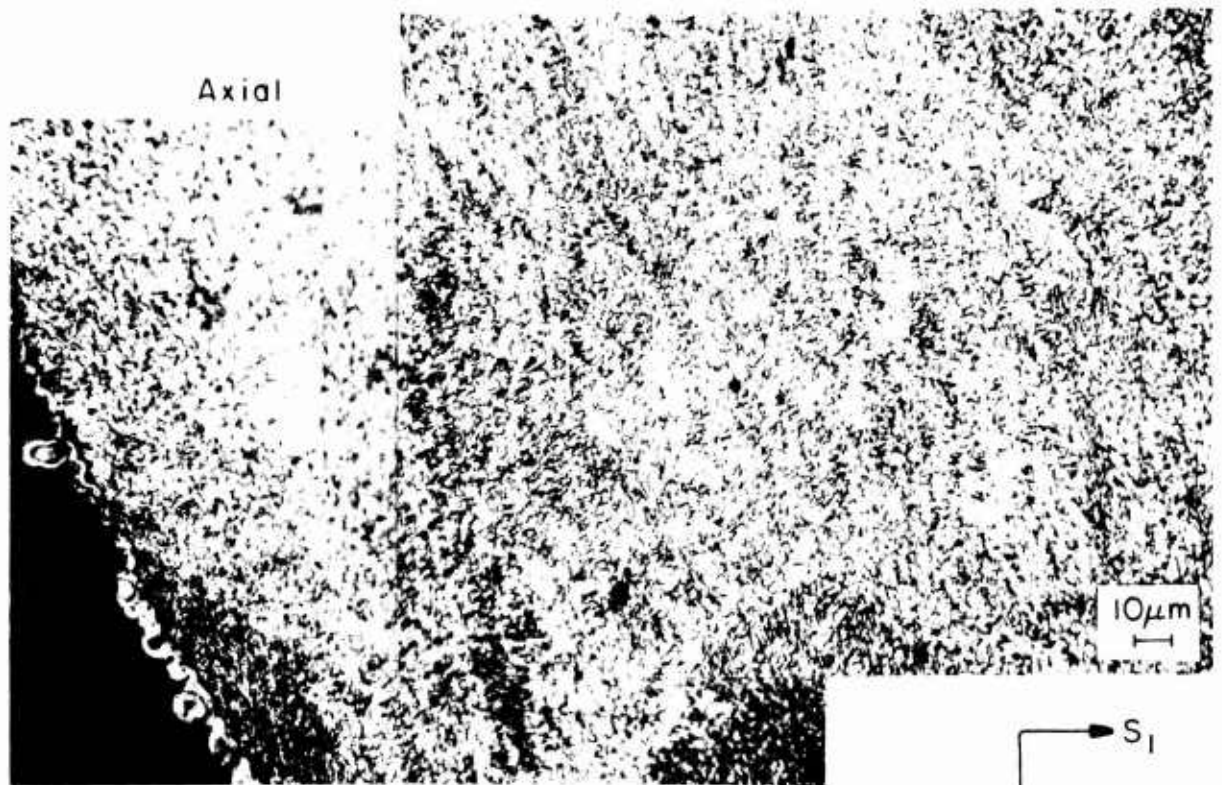

Figure 227. Alloy 227, sample 7T2. Crack path X500, void group adjacent to larger alpha particles X1200.

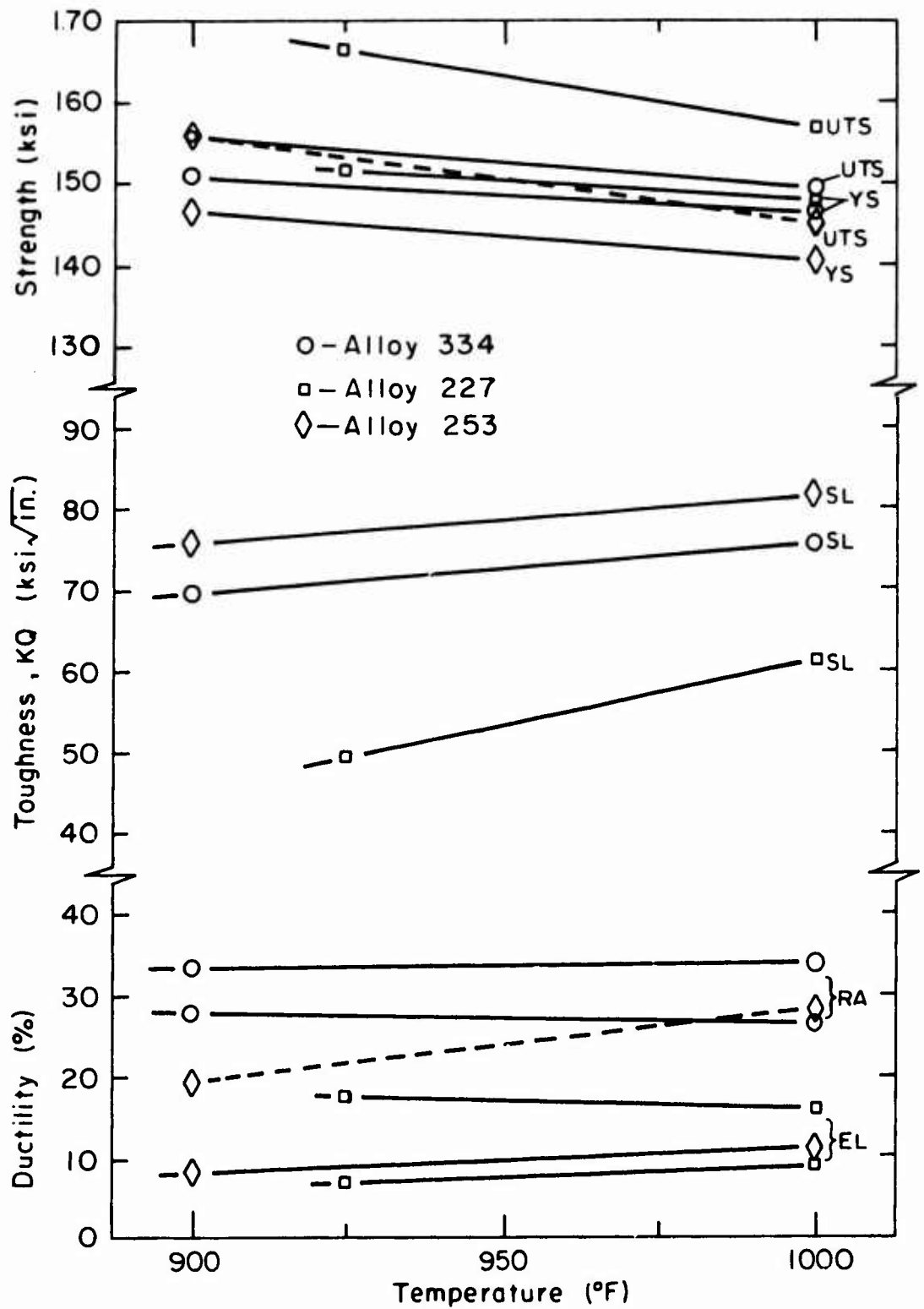

Figure 228. Effect of aging temperature on mechanical properties, transverse center six inch section, for alloy #334 (10Mo-8V-2.5Al), #227 (7Mo-4Cr-2.5Al) and #253 (10Mo-8V-2.5Al).

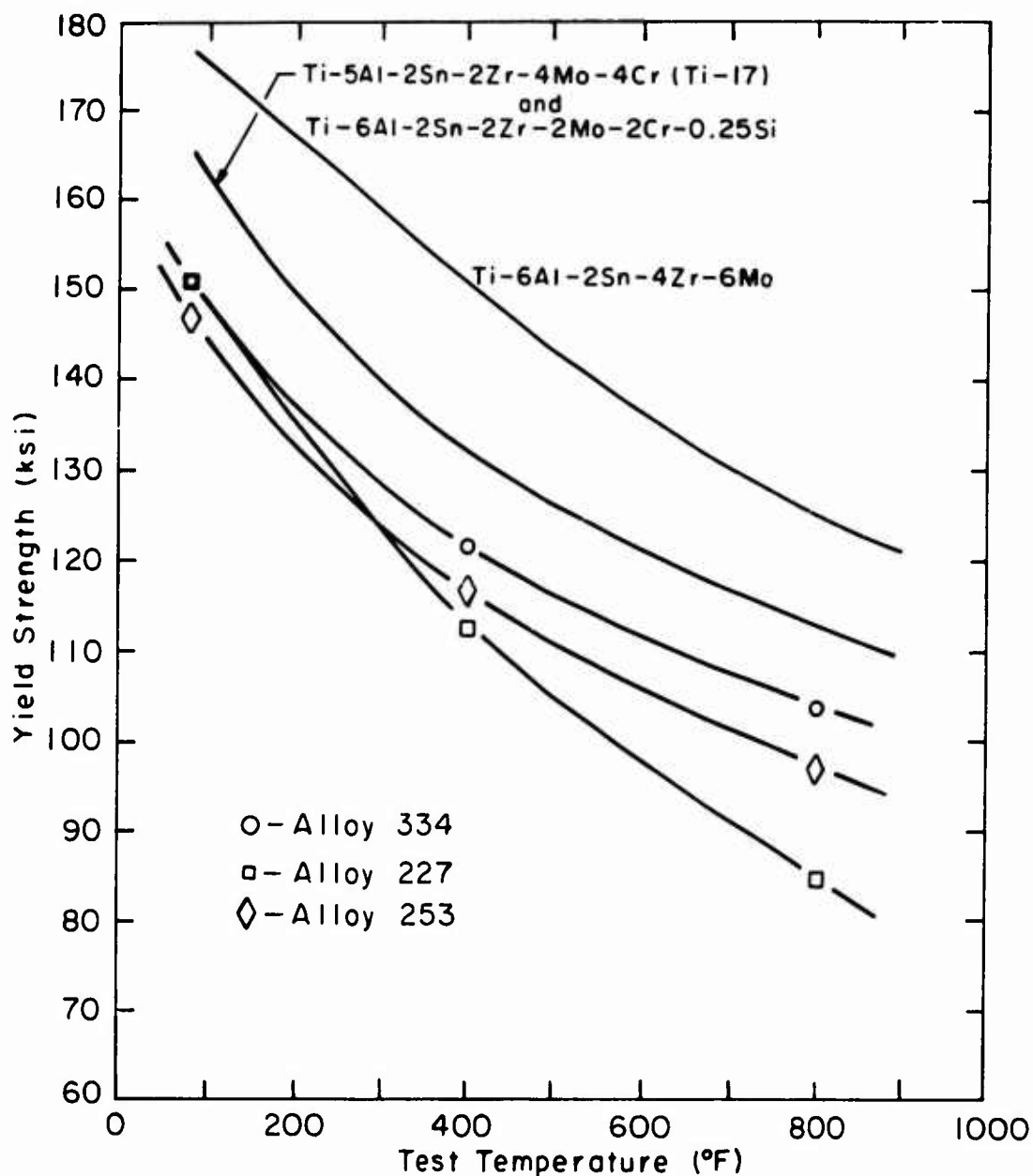

Figure 229. Comparison of elevated temperature transverse yield strength, center six inch section contract alloys with reported data from other deep hardenable alloys (27) (longitudinal direction for 6-22-22S, not specified for other alloys). Note that present alloys, heat-treated to a lower strength condition, follow similar trend lines.

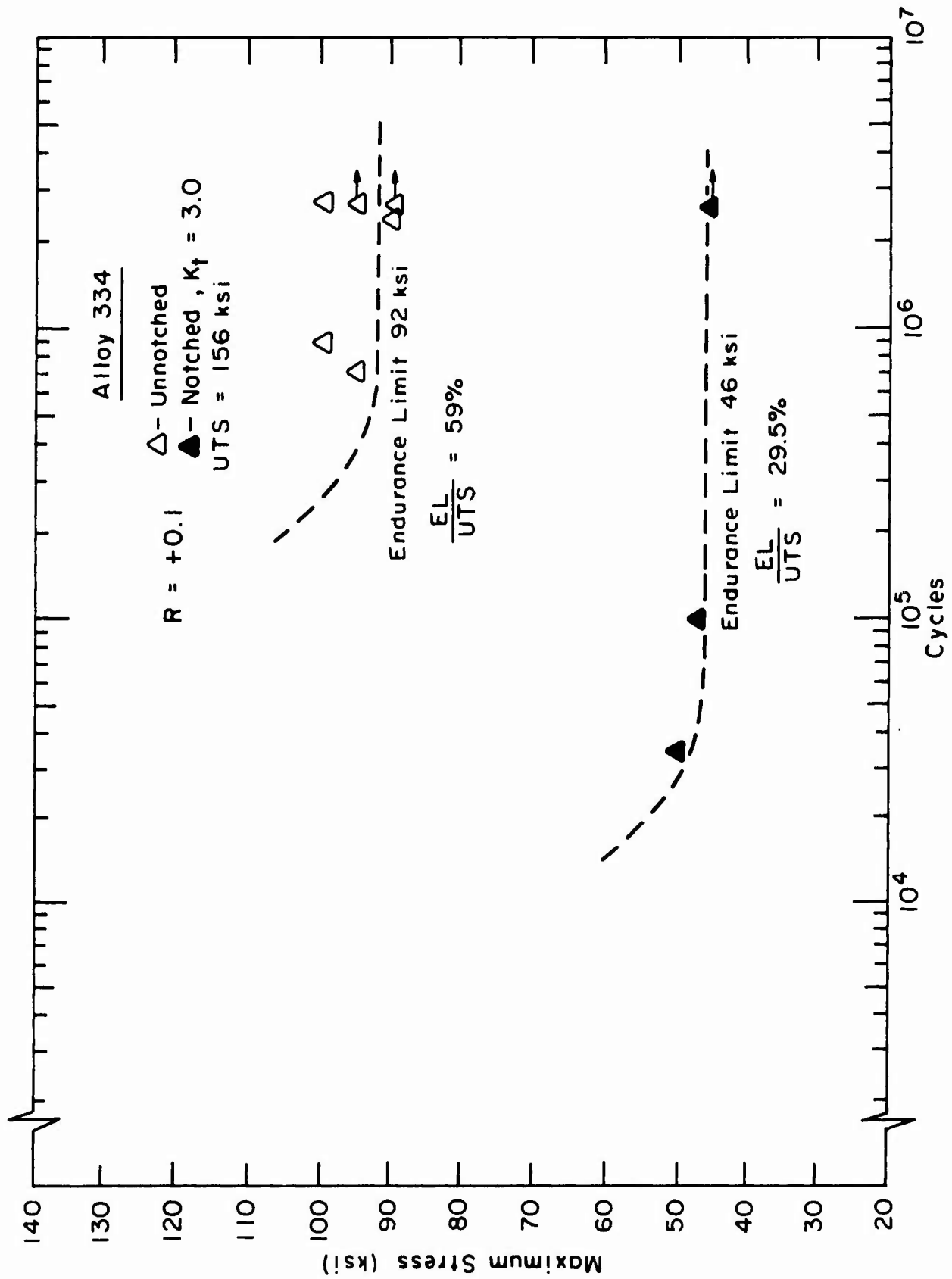

Figure 230. Fatigue behavior of alloy 334 (10Mo-6Cr-2.5Al). Transverse samples, center location 6 inch section.

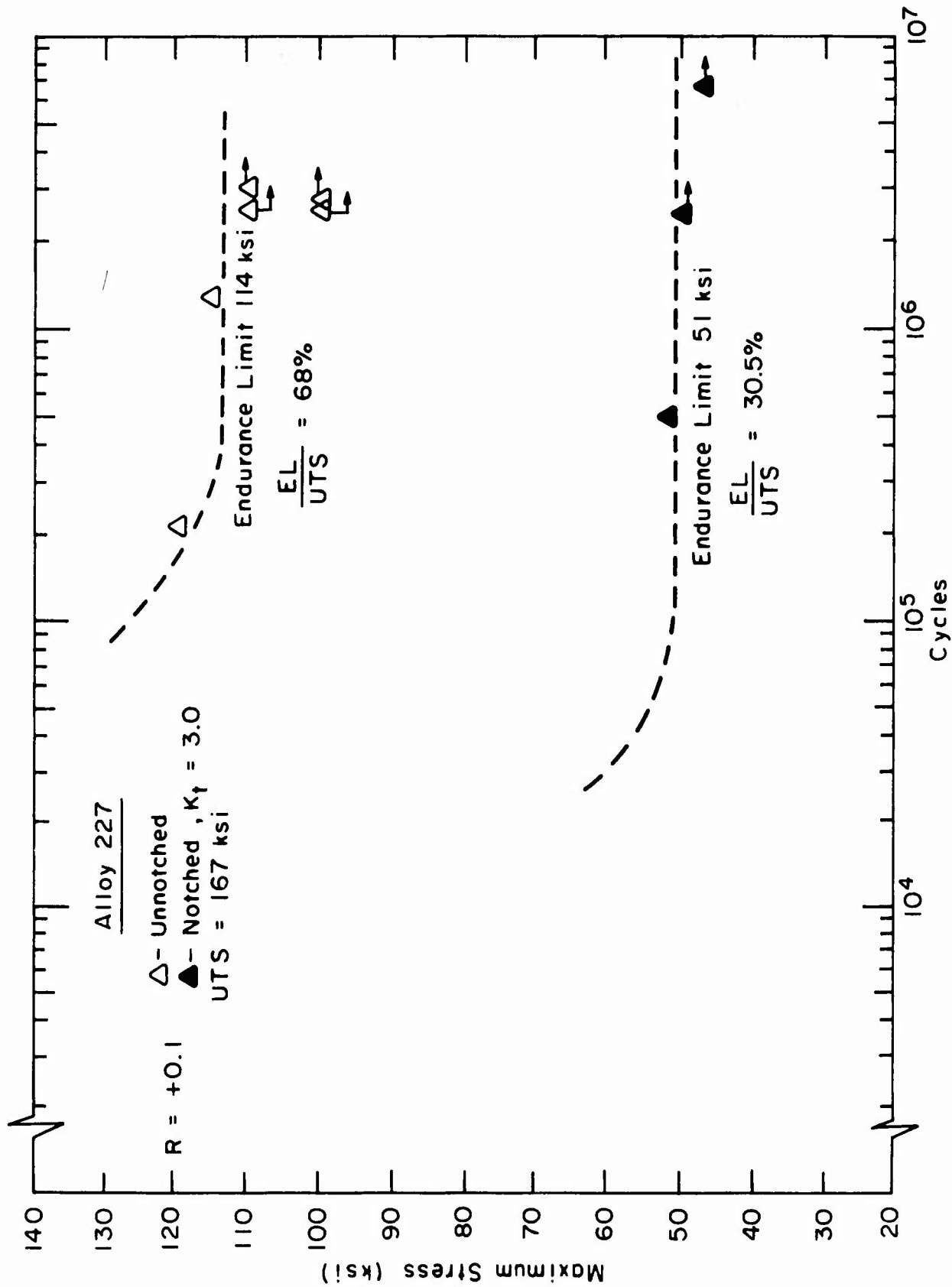

Figure 231. Fatigue behavior of alloy 227 (7Mo-4Cr-2.5Al). Transverse samples, center location 6 inch section

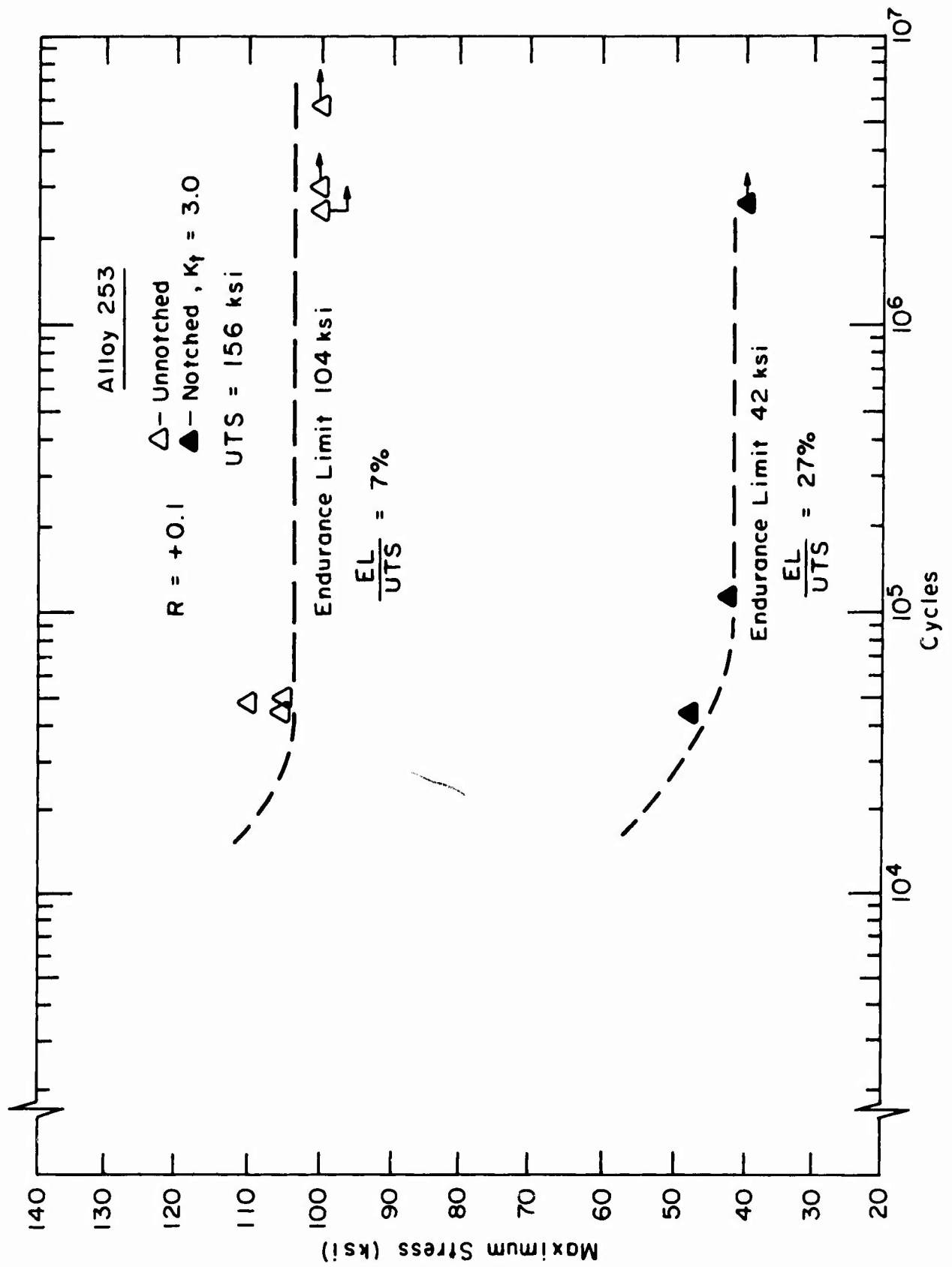

Figure 232. Fatigue behavior of alloy 253 (10Mo-8V-2.5Al). Transverse samples, center location 6 inch section.

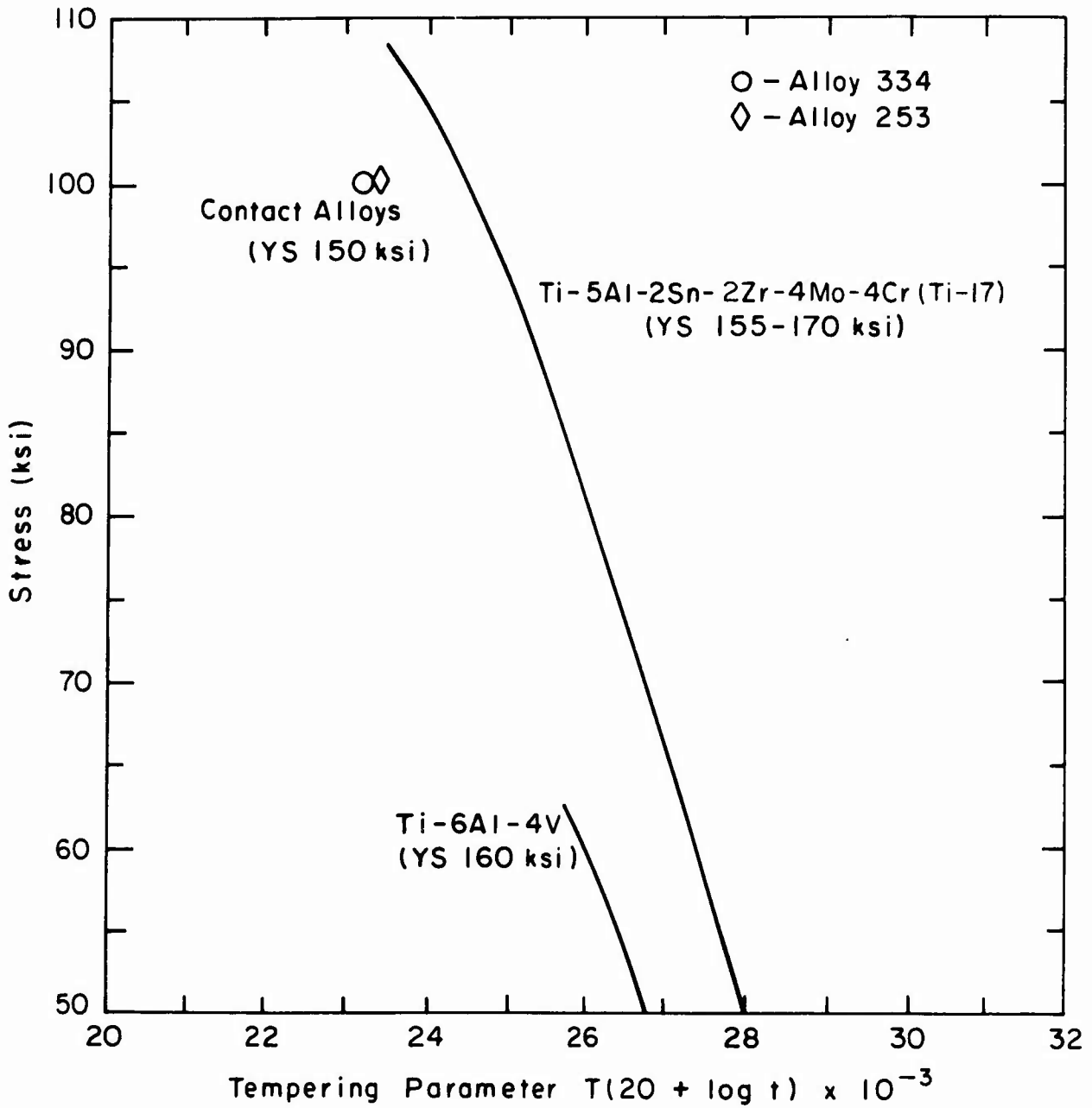

Figure 233. Larson-Miller creep curves at 0.2% plastic deformation for contact alloys and other titanium alloys^(28, 42) at the 150-170 ksi yield strength level.

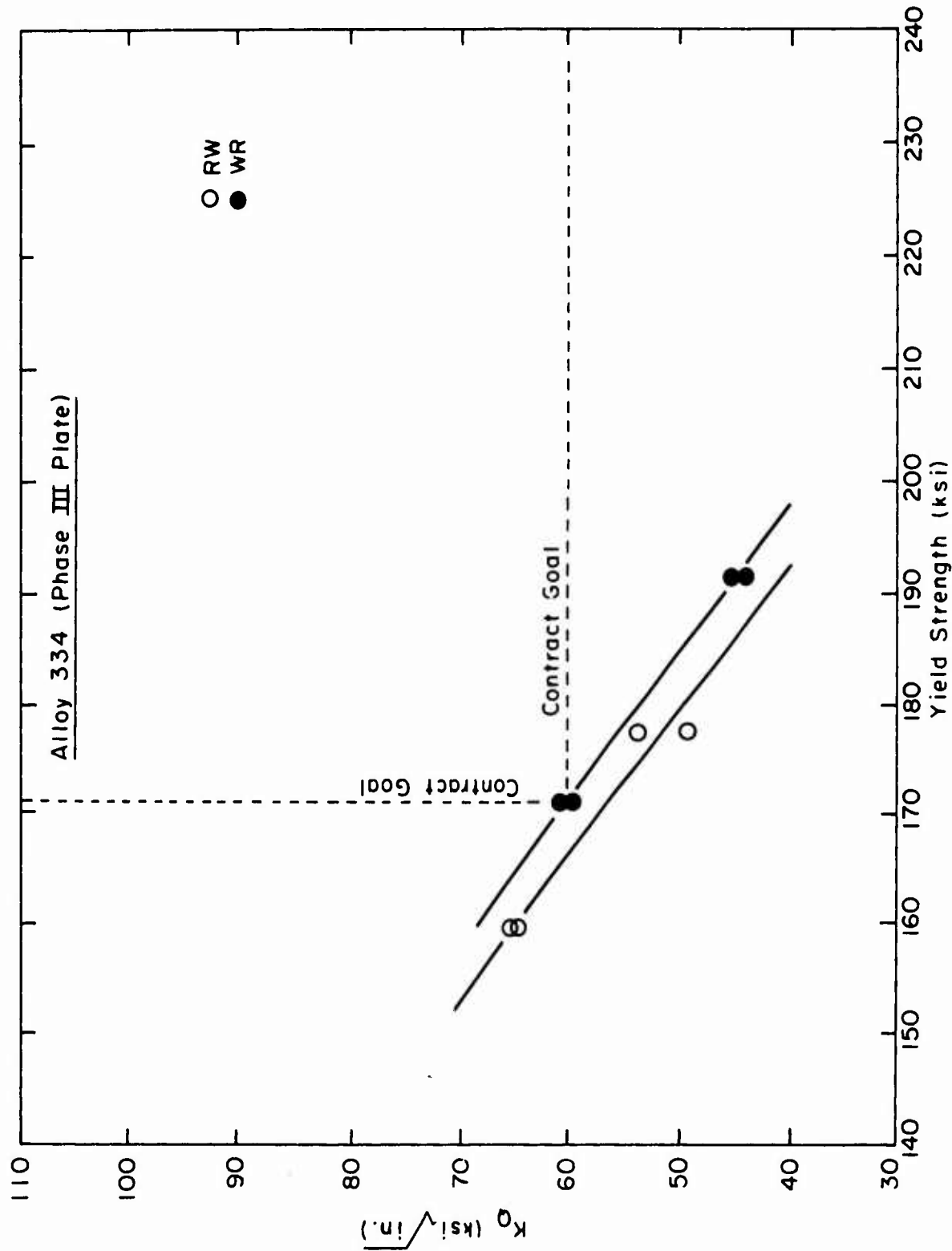

Figure 234. Alloy 334 (10Mo-6Cr-2.5Al), Phase III half-inch plate. Toughness (K_Q) - yield strength trend lines.

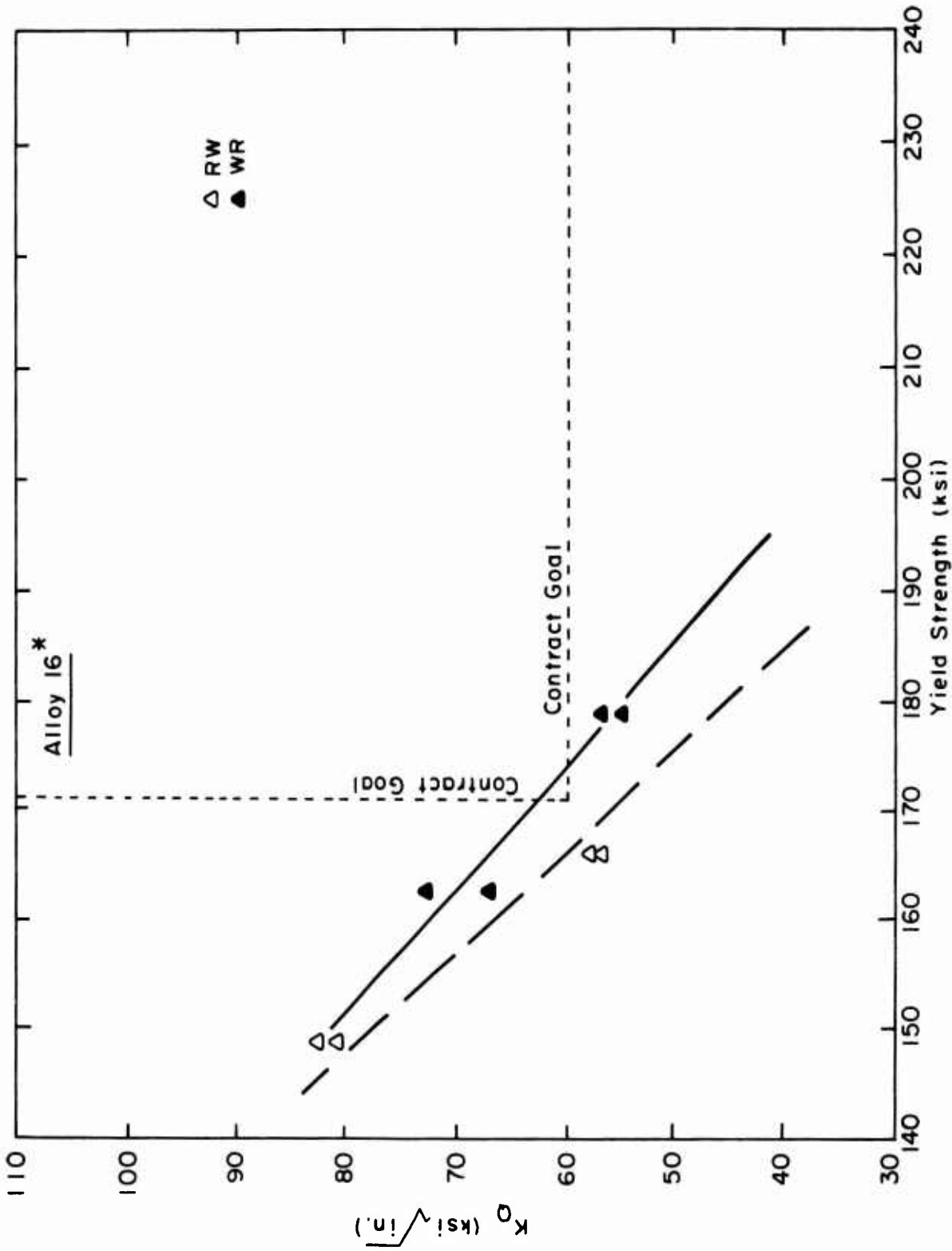

Figure 235. Alloy 16 (8Mo-4.5Cr-2.5Al). Half inch plate. *Data developed under the NAVAIR program. (22) Toughness (K_Q) - Yield strength trend lines.

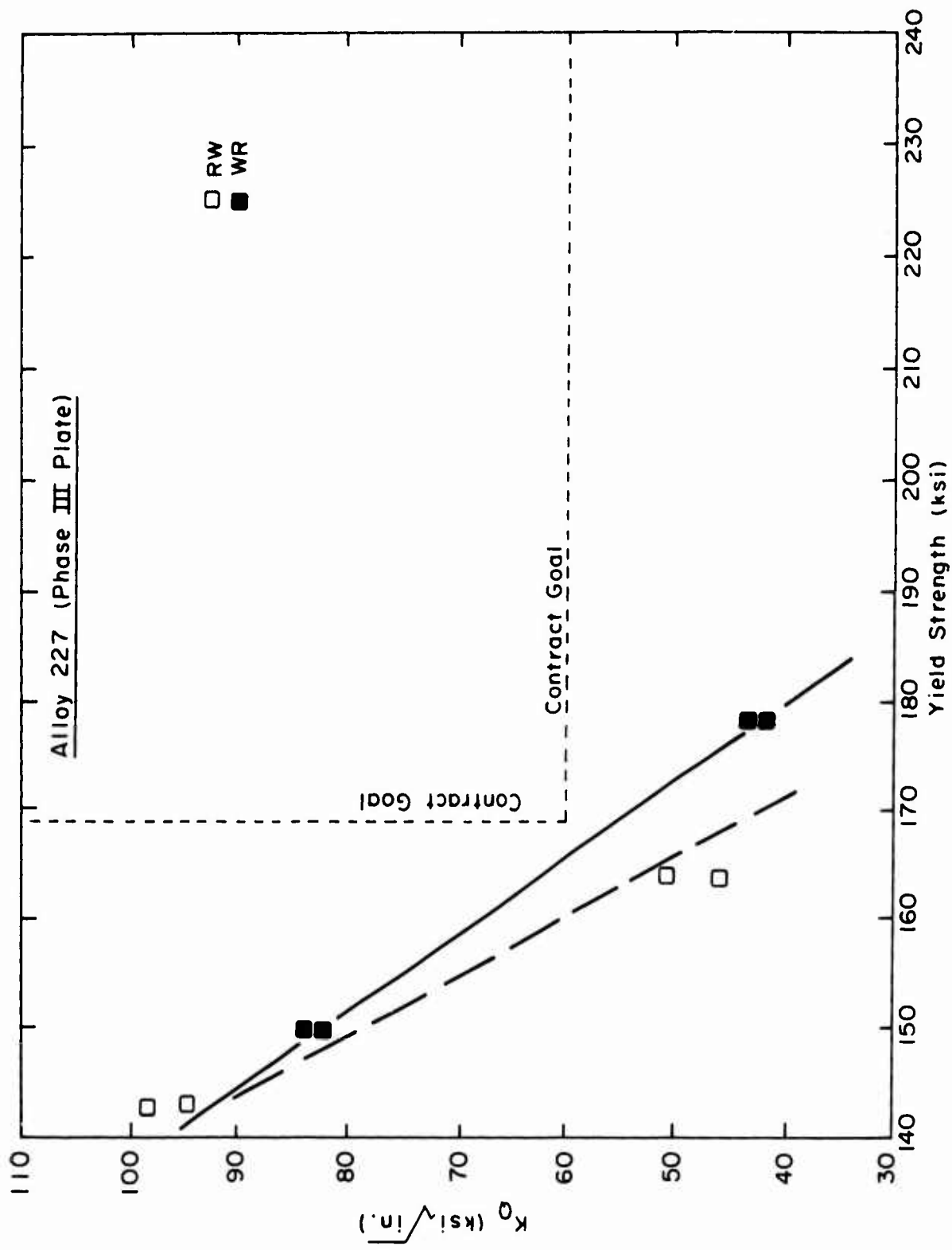

Figure 236. Alloy 227 (7Mo-4Cr-2.5Al), Phase III half-inch plate. Toughness (K_Q) - Yield strength trend lines.

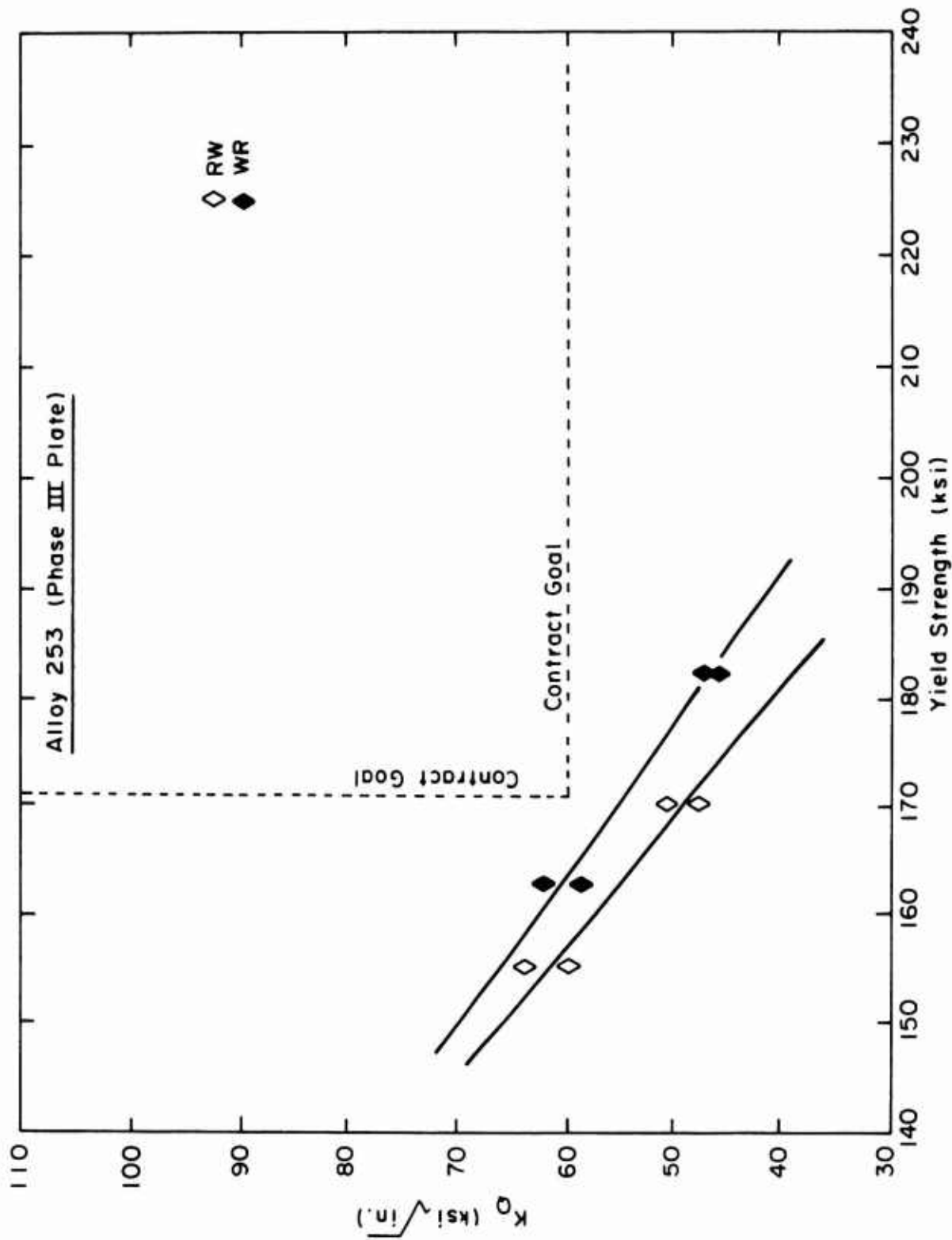

Figure 237. Alloy 253 (10Mo-8V-2.5Al), Phase III half-inch plate. Toughness (KQ) - Yield strength trend lines.

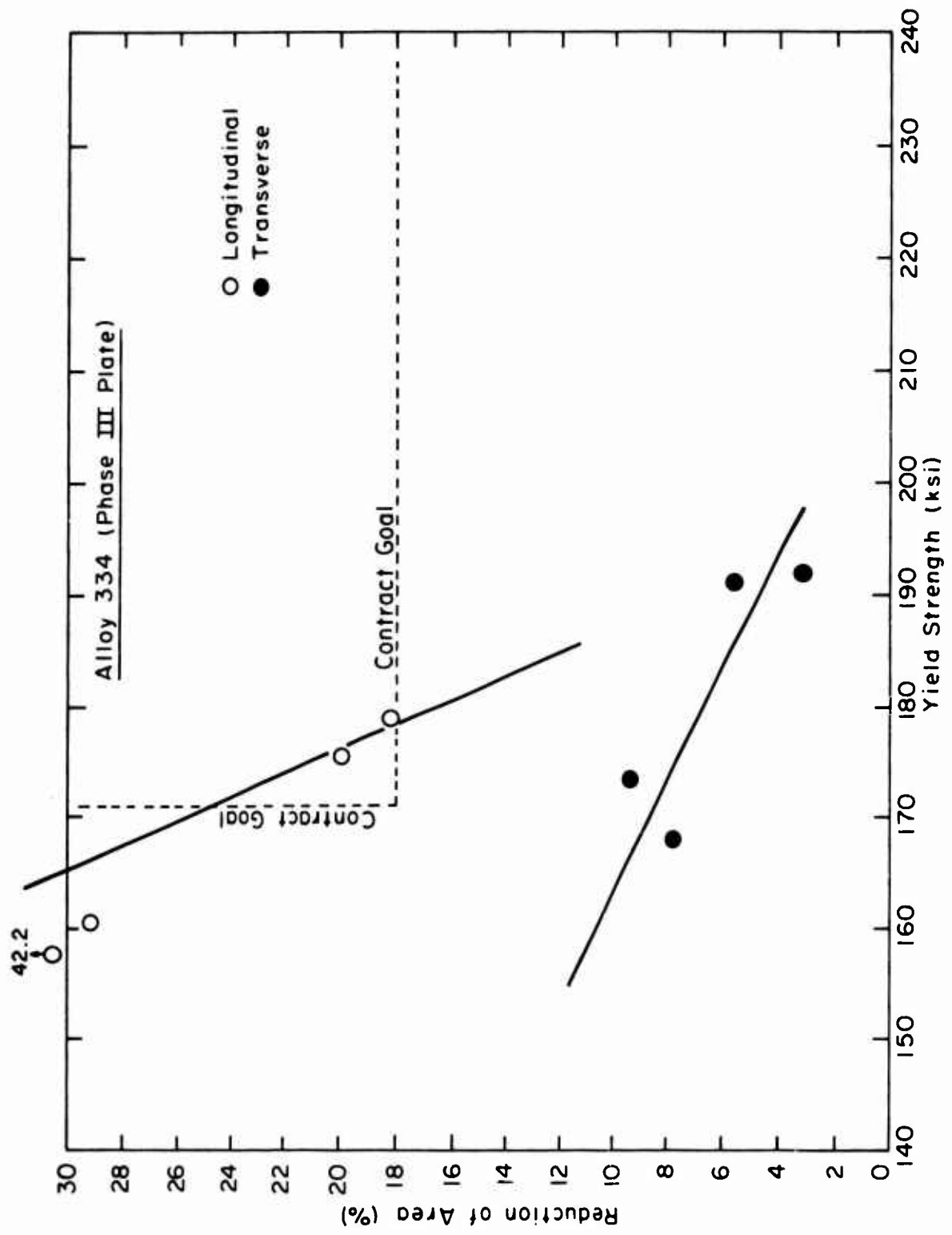

Figure 238. Alloy 334 (10Mo-6Cr-2.5Al), Phase III half-inch plate. Reduction of Area - Yield strength trend lines.

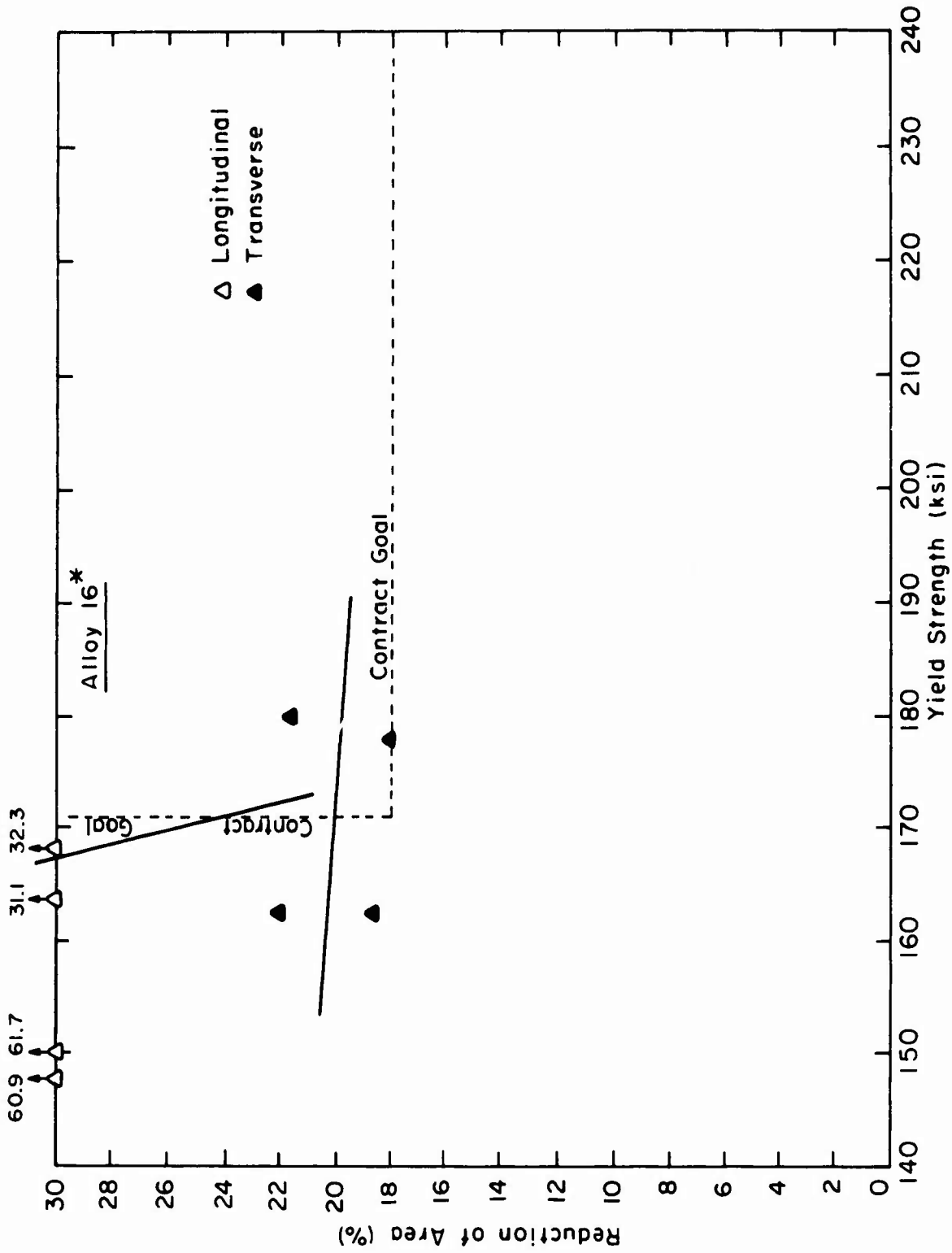

Figure 239. Alloy 16 (8Mo-4.5Cr-2.5Al). Half-inch plate. *Data developed under the NAVAIR program. (22) Reduction of Area - Yield strength trend lines.

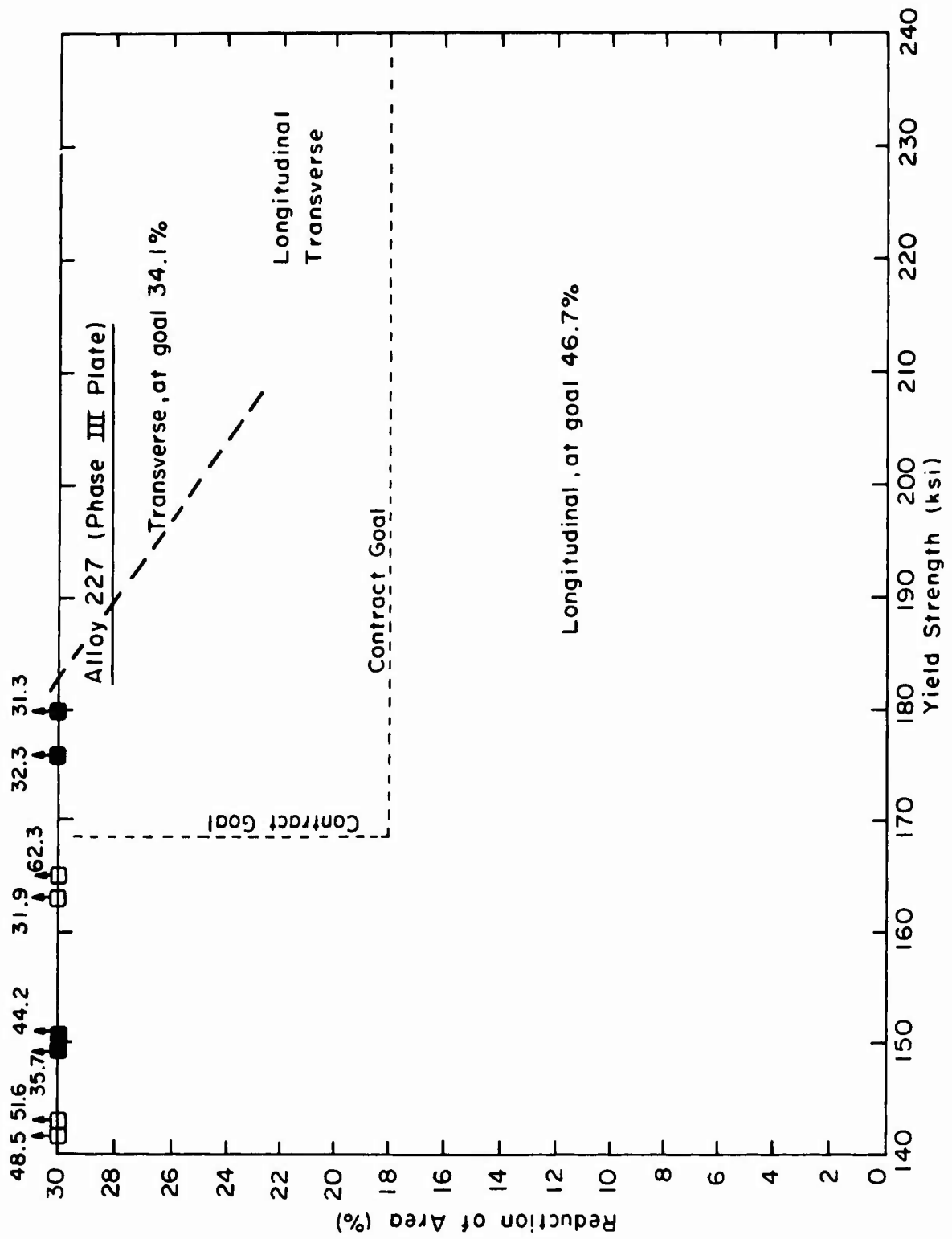

Figure 240. Alloy 227 (7Mo-4Cr-2.5Al). Phase III half-inch plate. Reduction of Area - Yield strength trend lines.

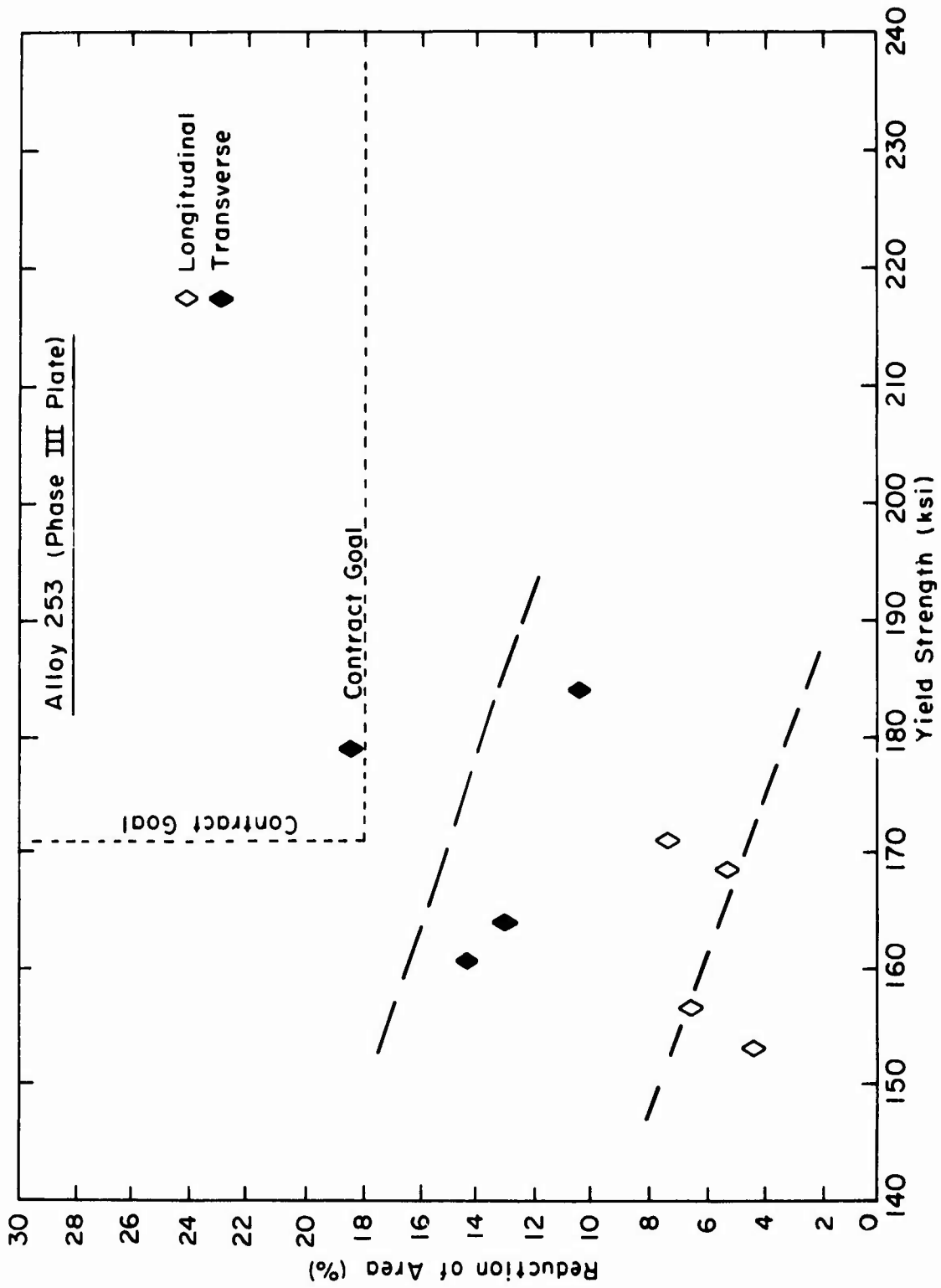

Figure 241. Alloy 253 (10Mo-8V-2.5Al). Phase III half-inch plate. Reduction of Area - Yield strength trend lines.

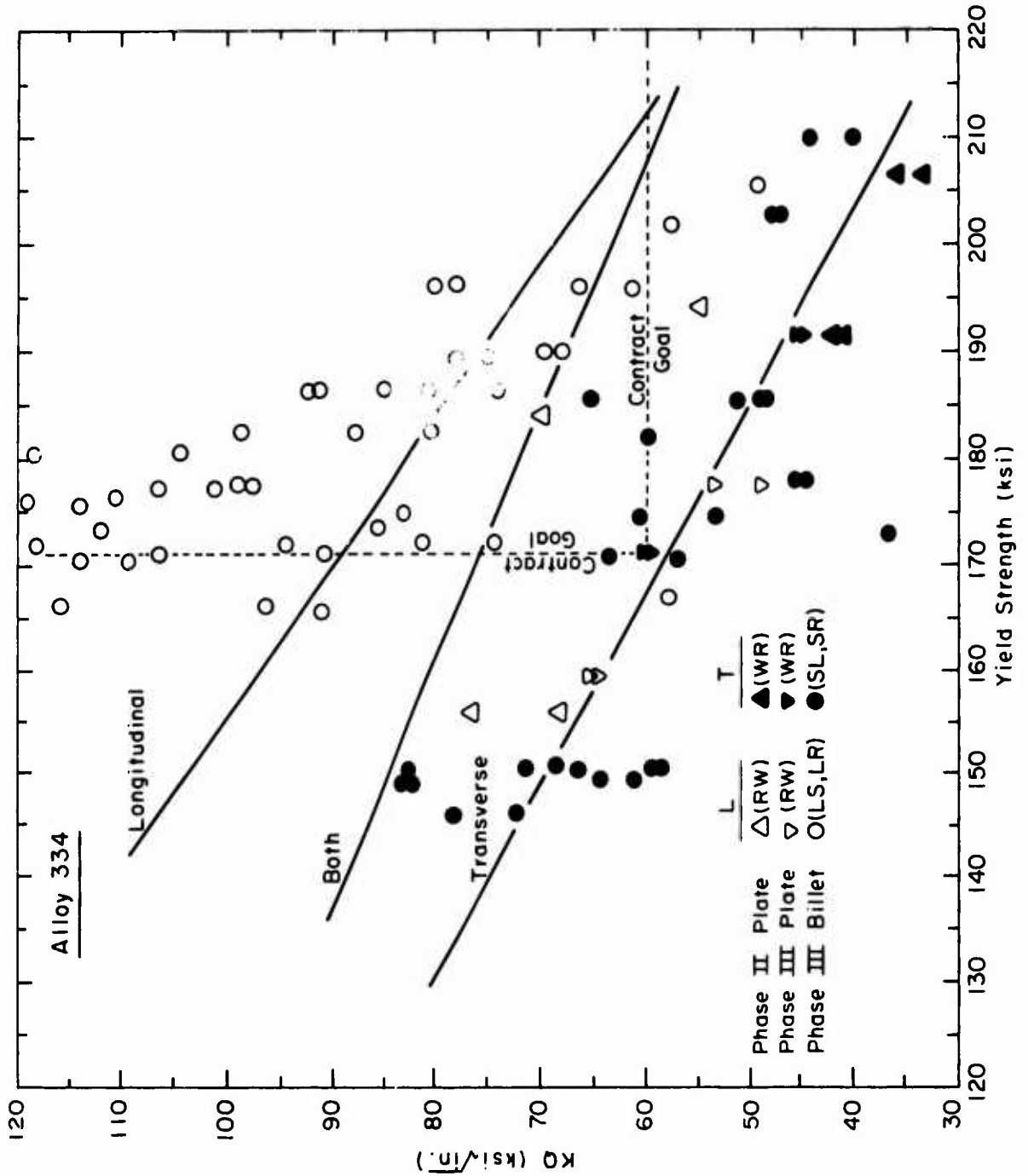

Figure 242. Alloy 334 (10Mo-6Cr-2.5Al). Overall alloy characteristic toughness (K_Q) - Yield strength trend lines.

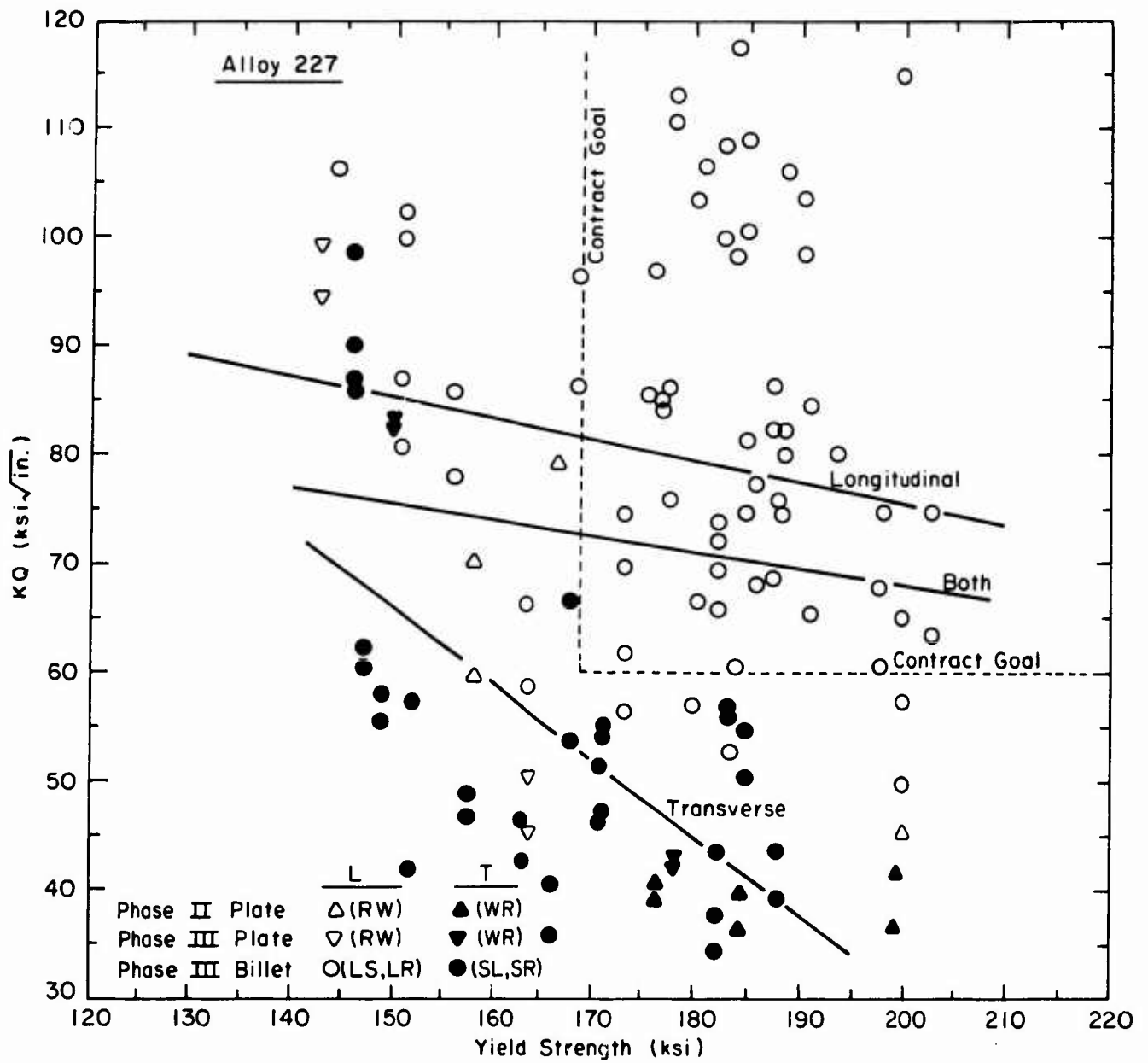

Figure 243. Alloy 227 (7Mo-4Cr-2.5Al). Overall alloy characteristic toughness (K_Q) - Yield strength trend lines.

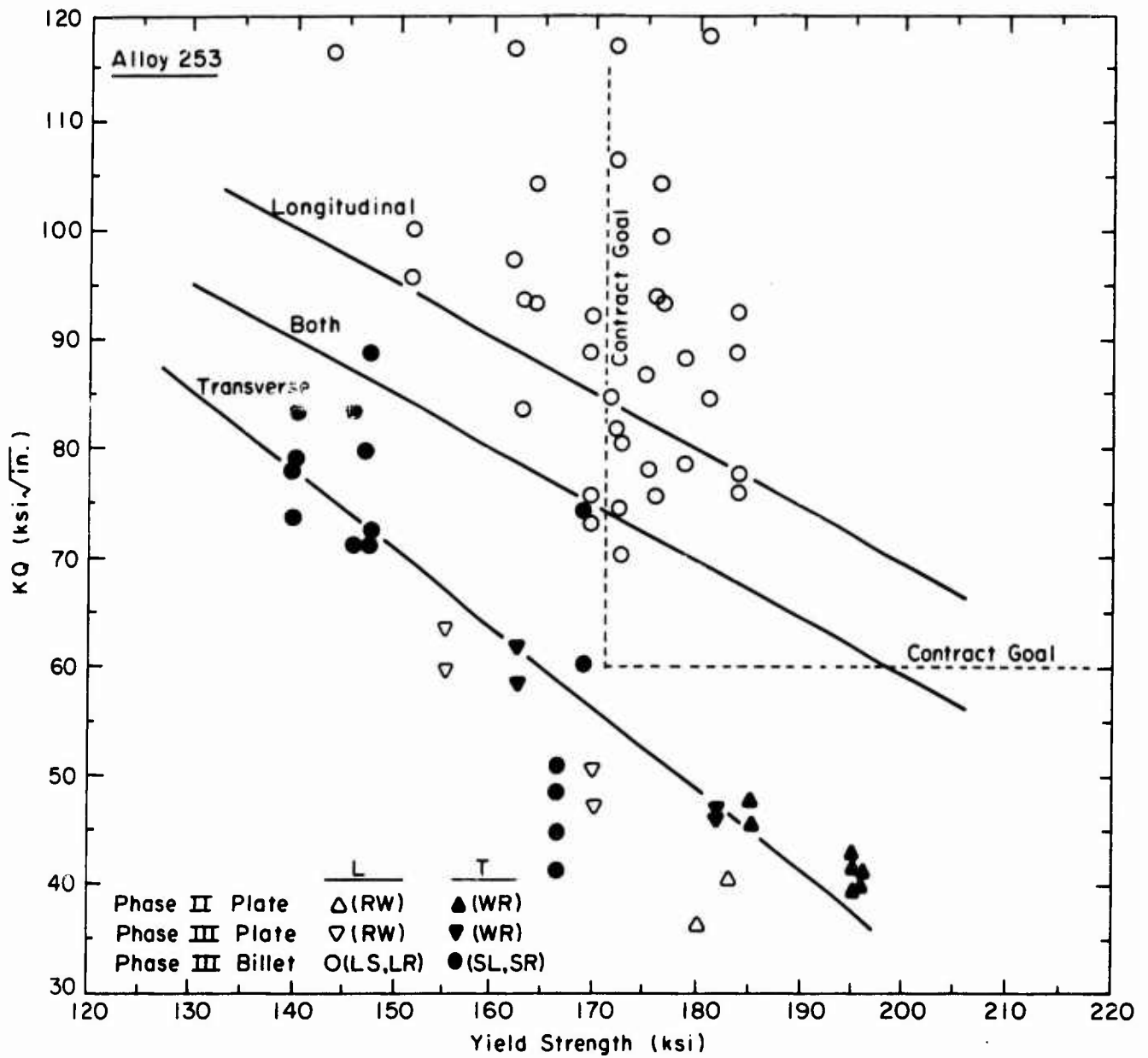

Figure 244. Alloy 253 (10Mo-8V-2.5Al). Overall alloy characteristic toughness (K_Q) Yield strength trend lines.

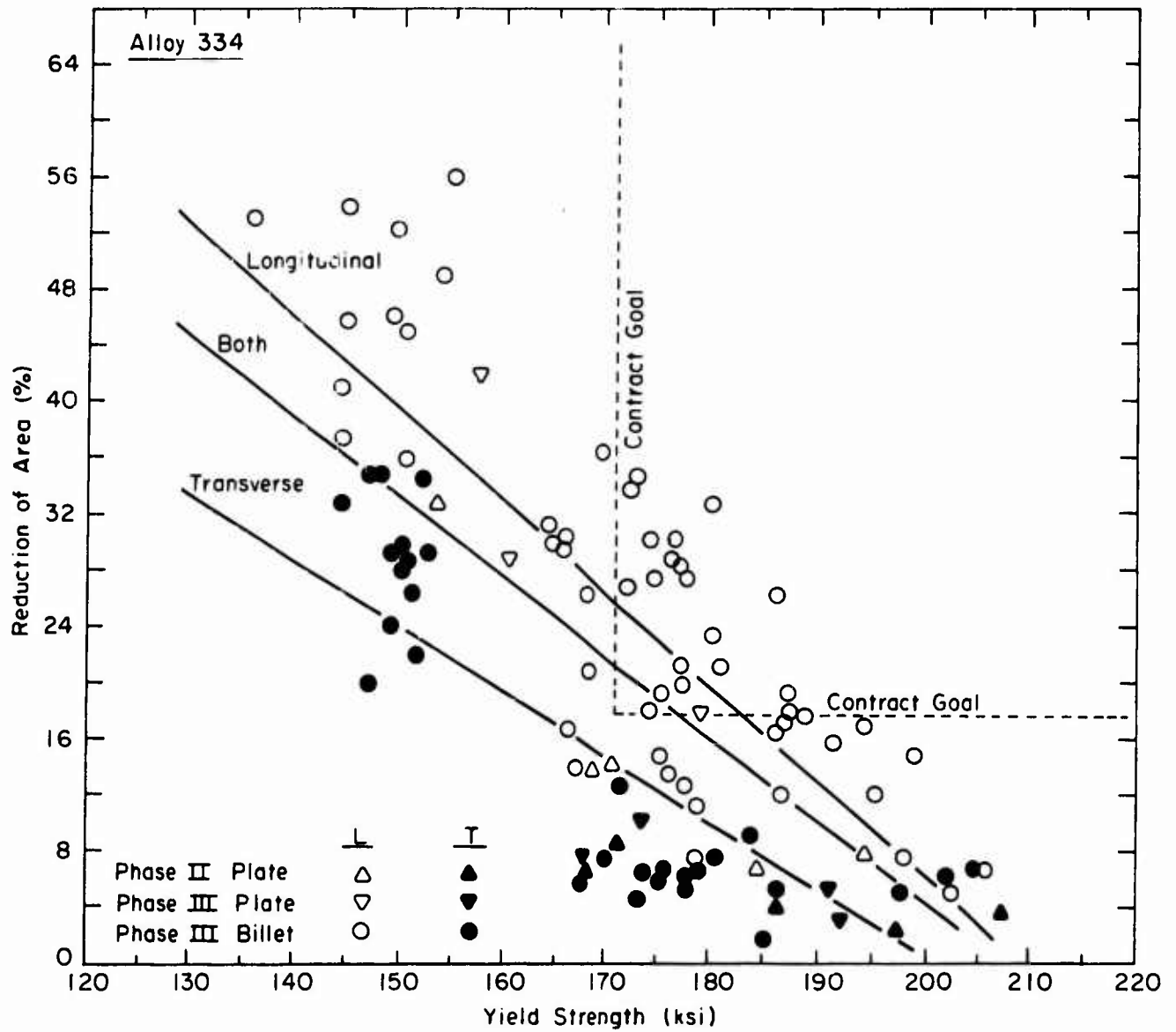

Figure 245. Alloy 334 (10Mo-6Cr-2.5Al). Overall alloy characteristic ductility (RA) - Yield strength trend lines.

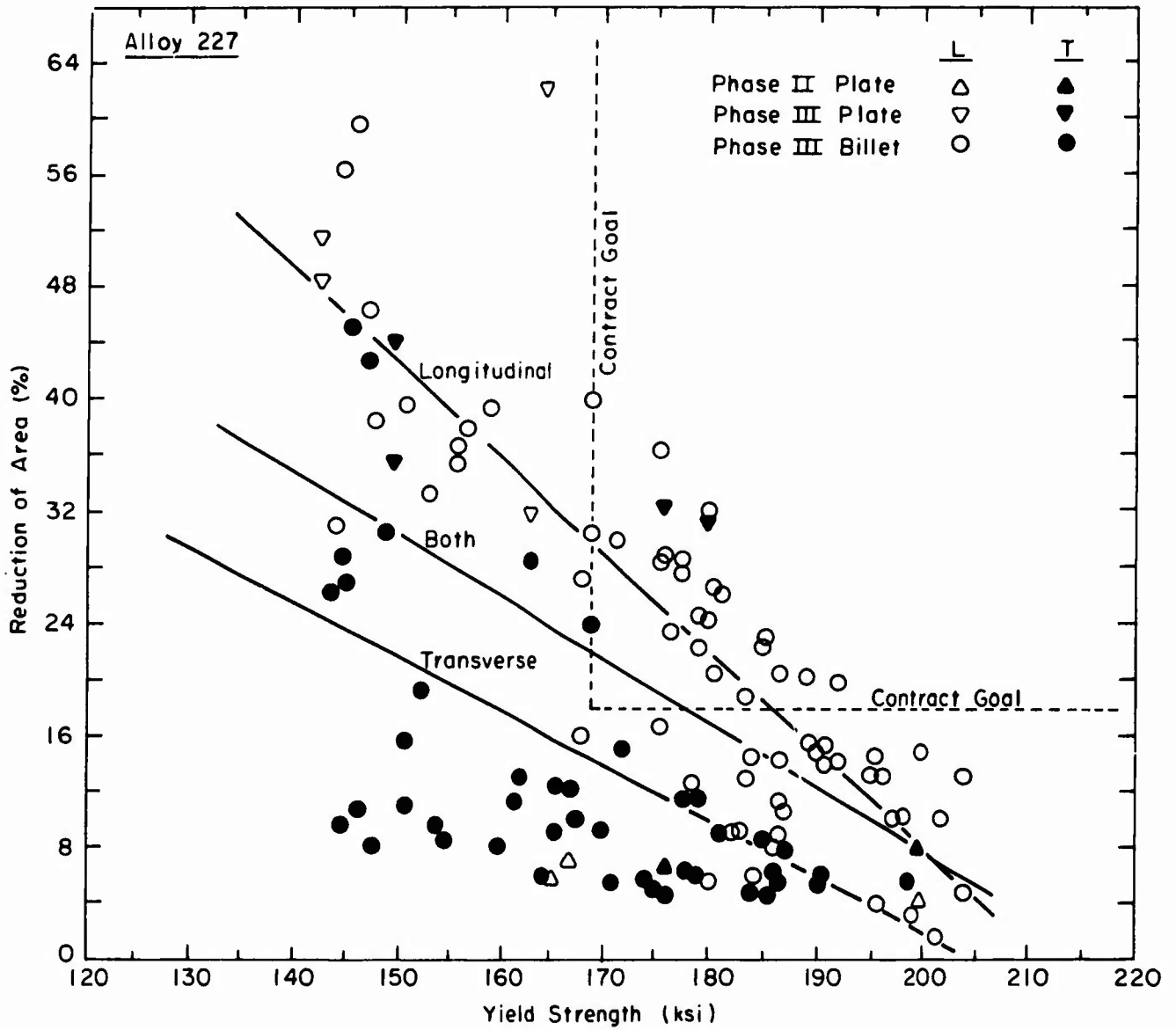

Figure 246. Alloy 227 (7Mo-4Cr-2.5Al). Overall alloy characteristic ductility (RA) Yield strength trend lines.

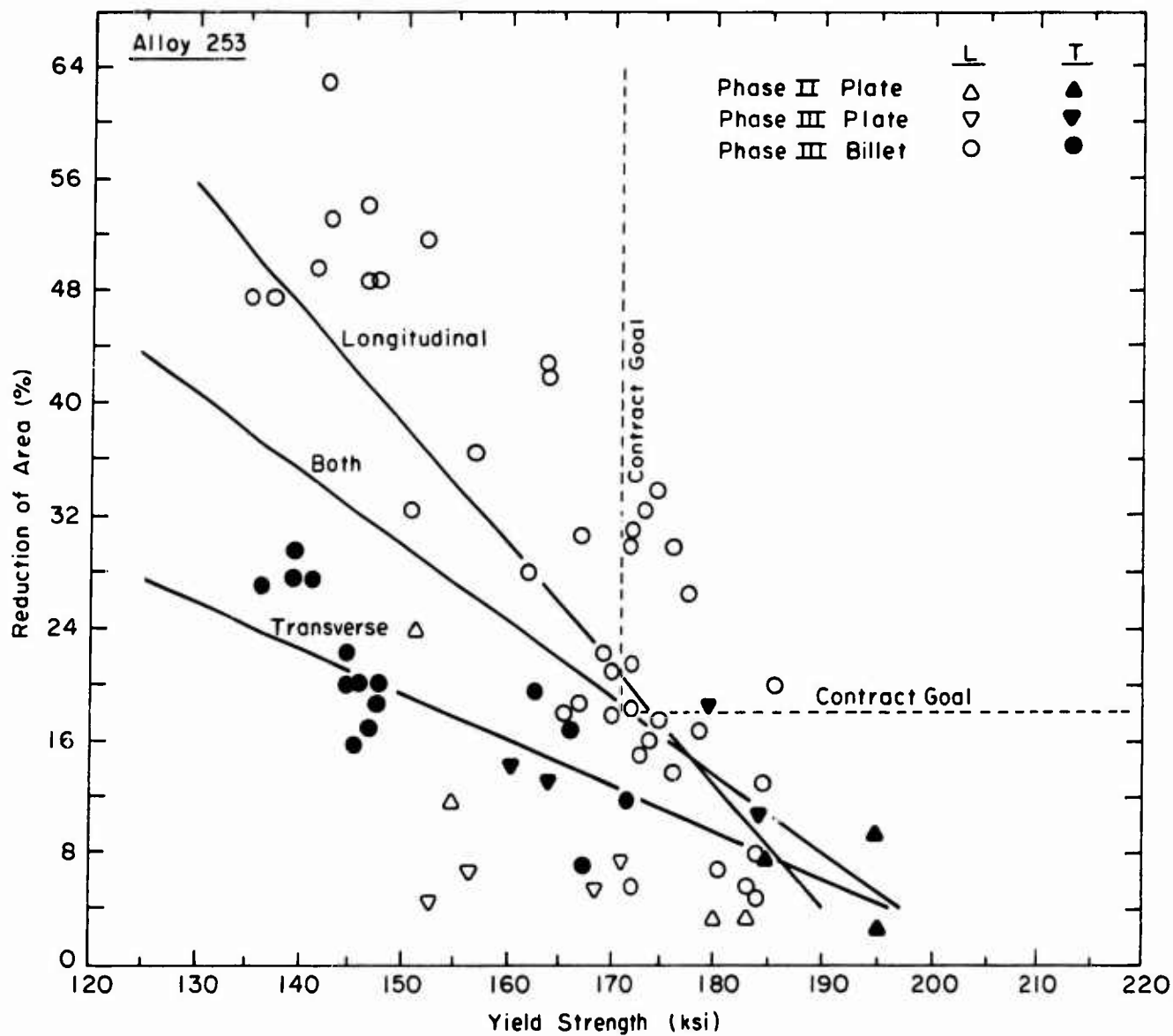

Figure 247. Alloy 253 (10Mo-8V-2.5Al). Overall alloy characteristic ductility (RA) - Yield strength trend lines.

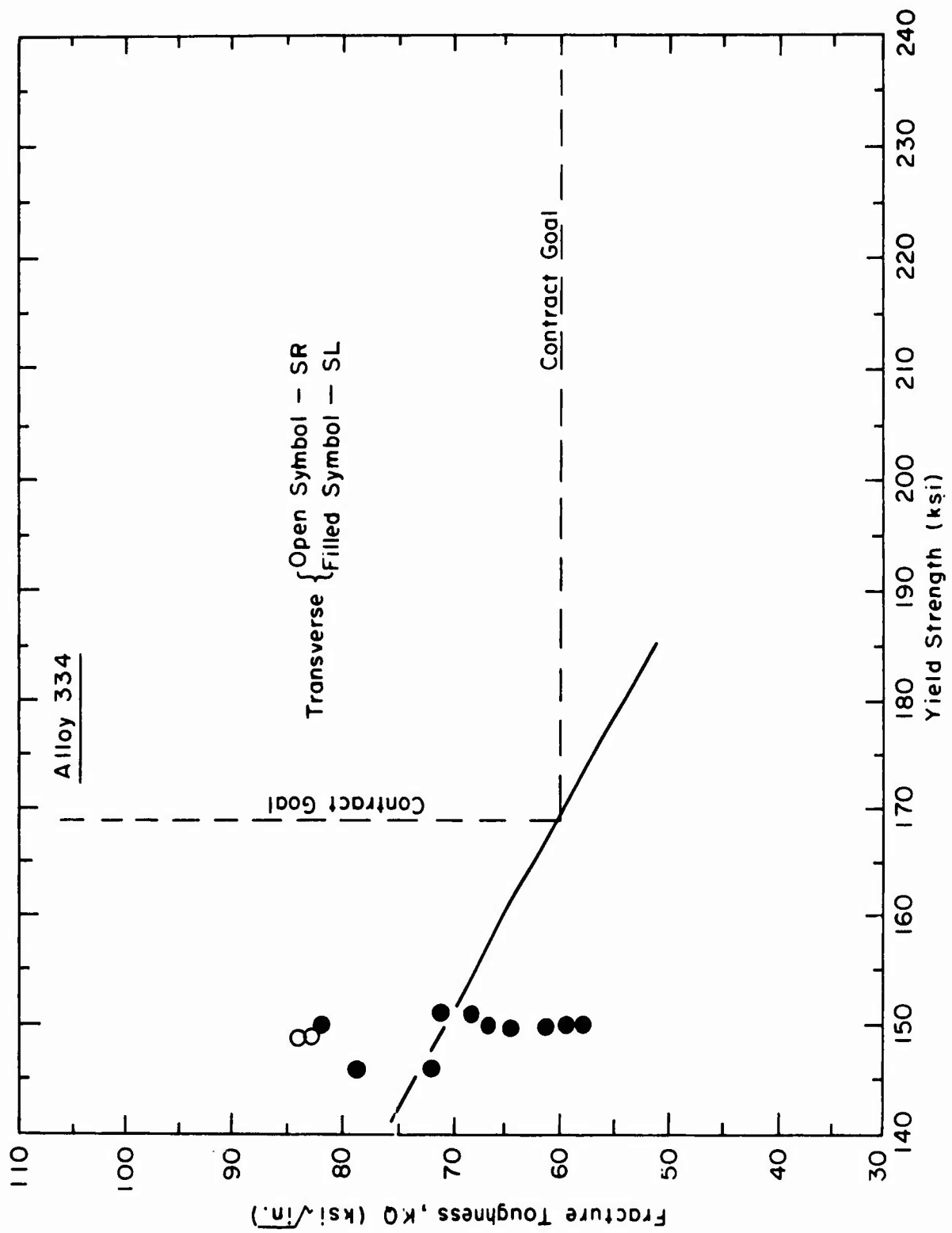

Figure 248. Alloy 334 (10Mo-6Cr-2.5Al). Transverse alloy characteristic toughness (KQ) - Yield strength trend line for "optimum" heat-treatment.

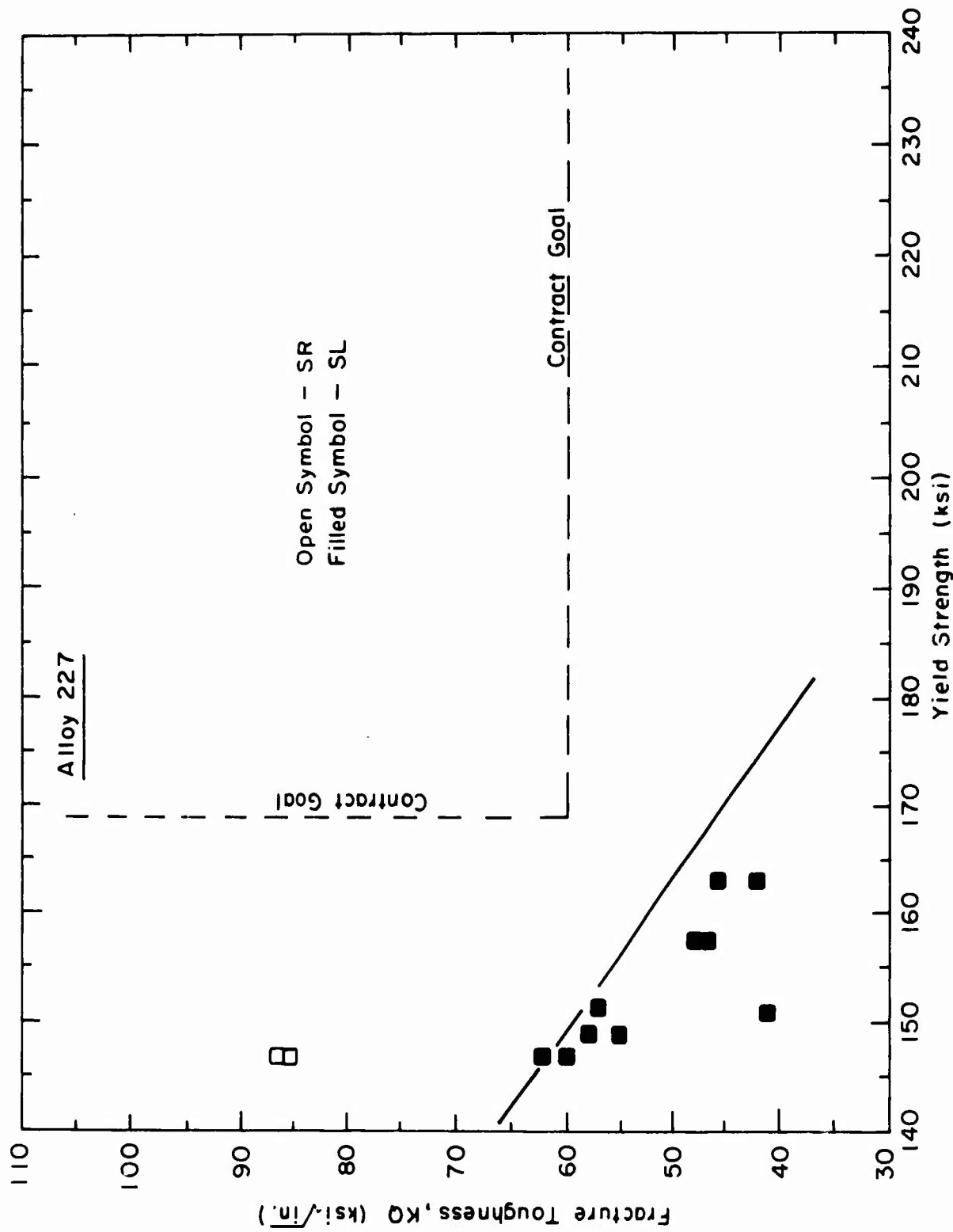

Figure 249. Alloy 227 (7Mo-4Cr-2.5Al). Transverse alloy characteristic toughness (K_Q) - Yield strength trend line for "optimum" heat-treatment.

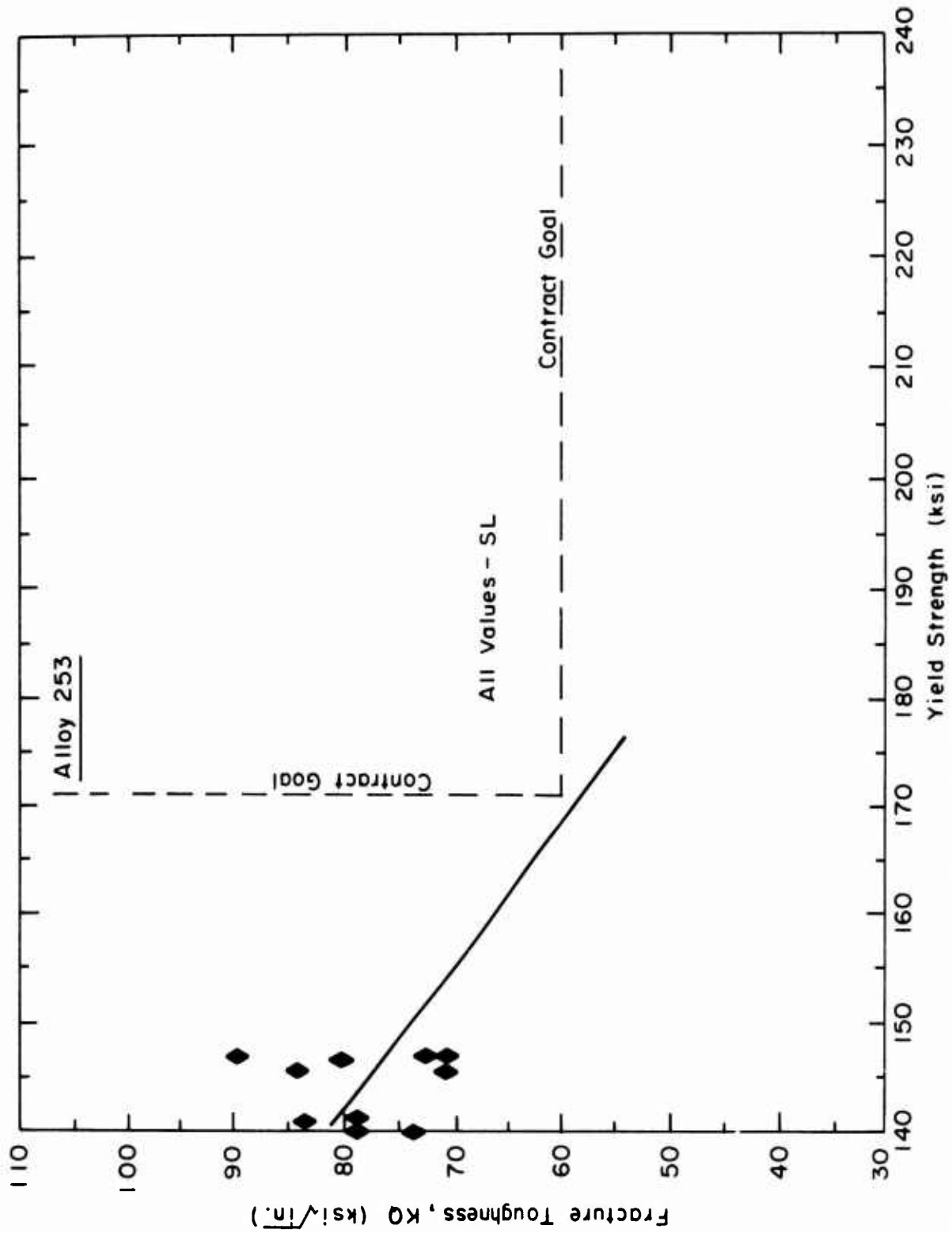

Figure 250. Alloy 253 (10Mo-8V-2.5Al). Transverse alloy characteristic toughness (K_Q) - Yield strength trend line for "optimum" heat-treatment.

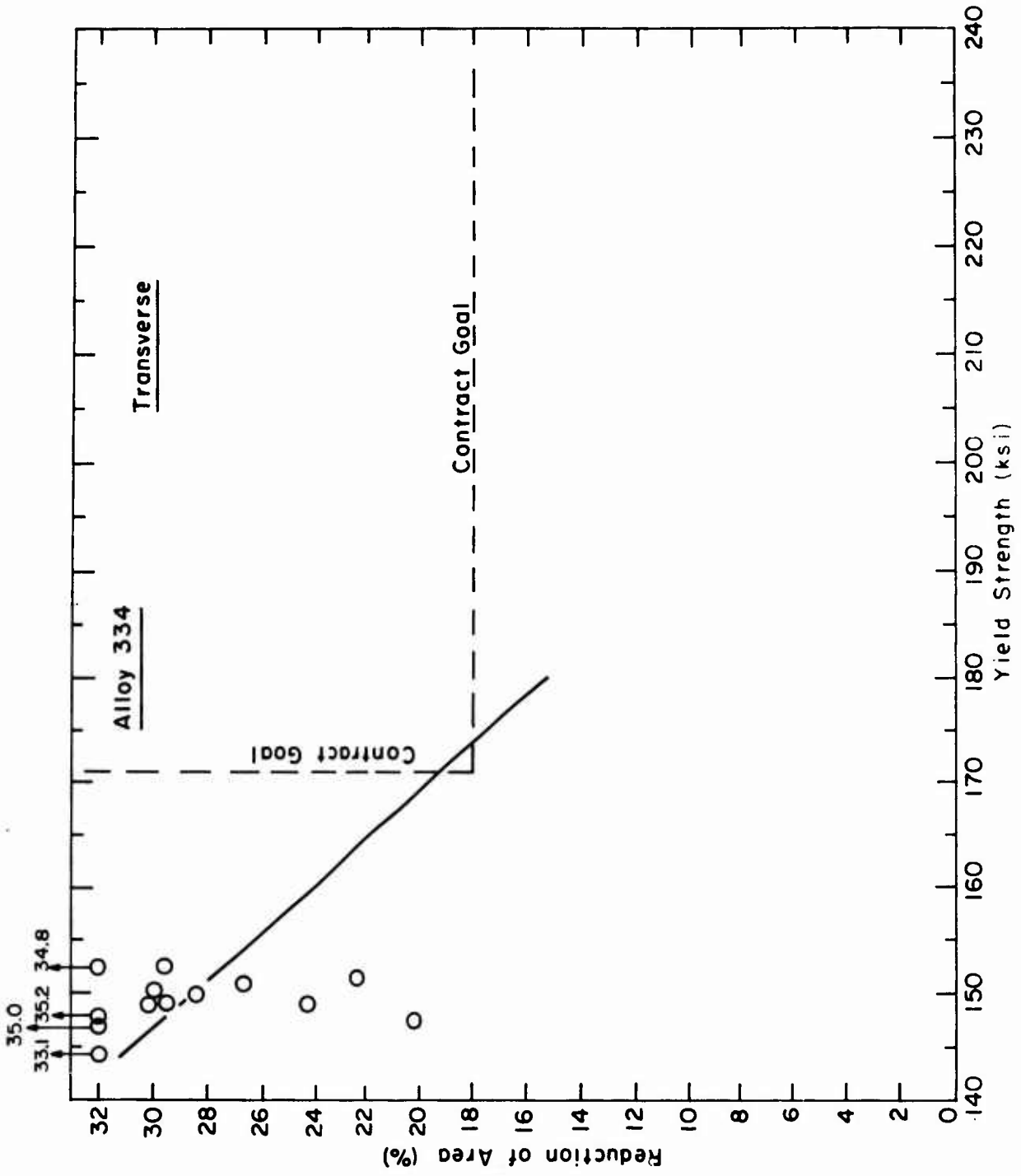

Figure 251. Alloy 334 (10Mo-6Cr-2.5Al). Transverse alloy characteristic reduction of area (RA) - Yield strength trend line for "optimum" heat-treatment.

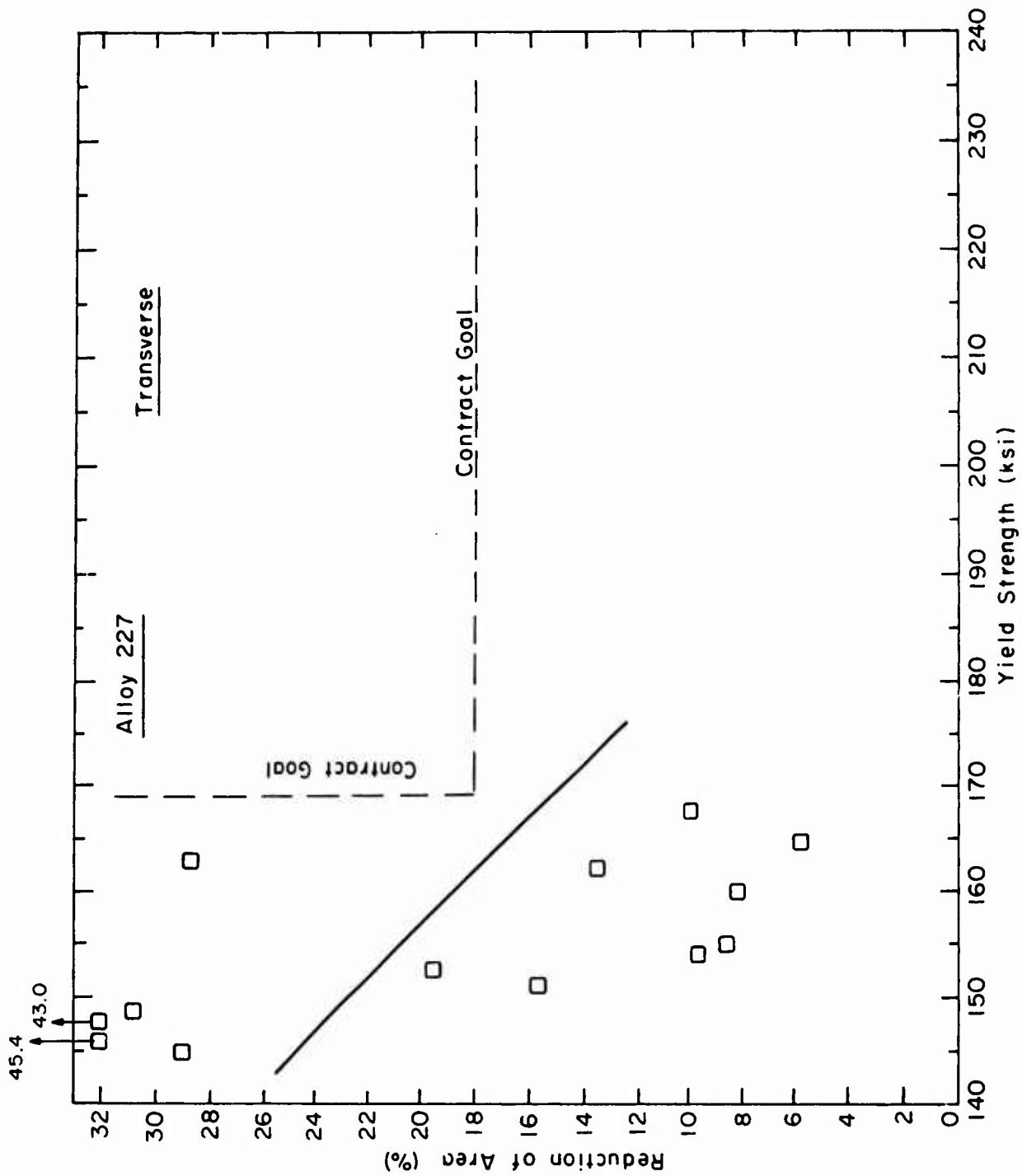

Figure 252. Alloy 227 (7Mo-4Cr-2.5Al). Transverse alloy characteristic reduction of area (RA) - Yield strength trend line for "optimum" heat-treatment.

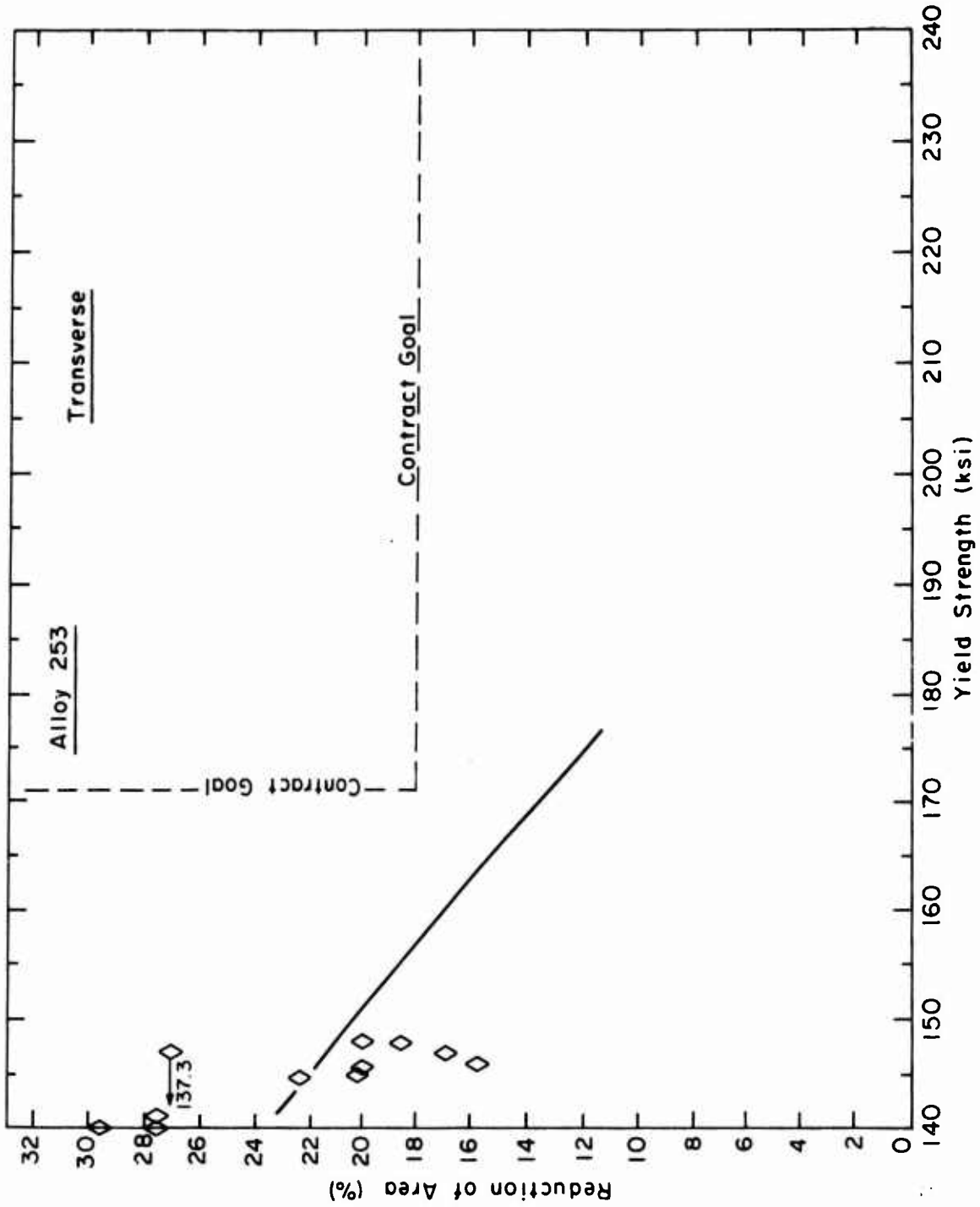

Figure 253. Alloy 253 (10Mo-8V-2.5Al). Transverse alloy characteristic reduction of area (RA) - Yield strength trend line for "optimum" heat-treatment.

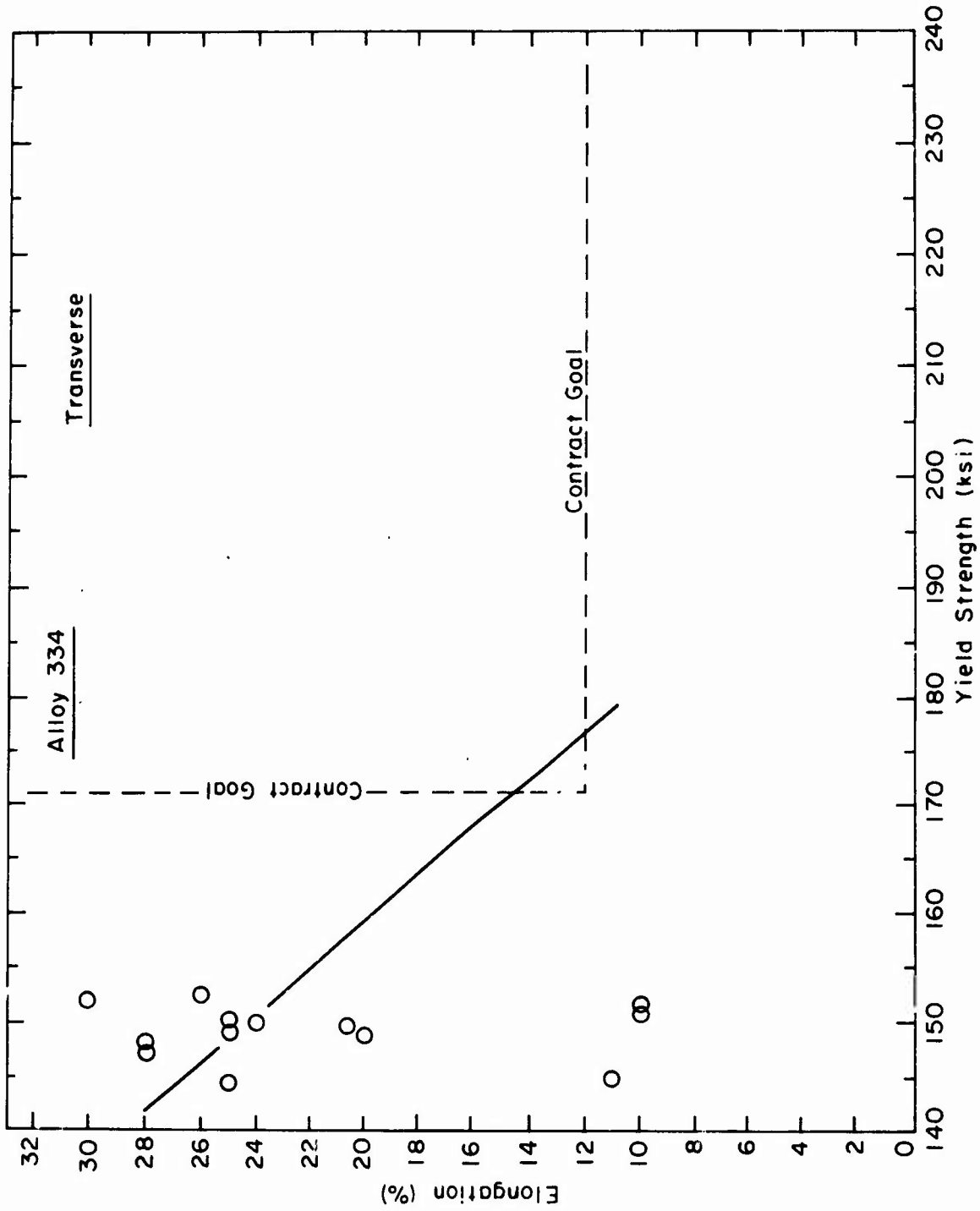

Figure 254. Alloy 334 (10Mo-6Cr-2.5Al). Transverse alloy characteristic elongation - Yield strength trend line for "optimum" heat-treatment.

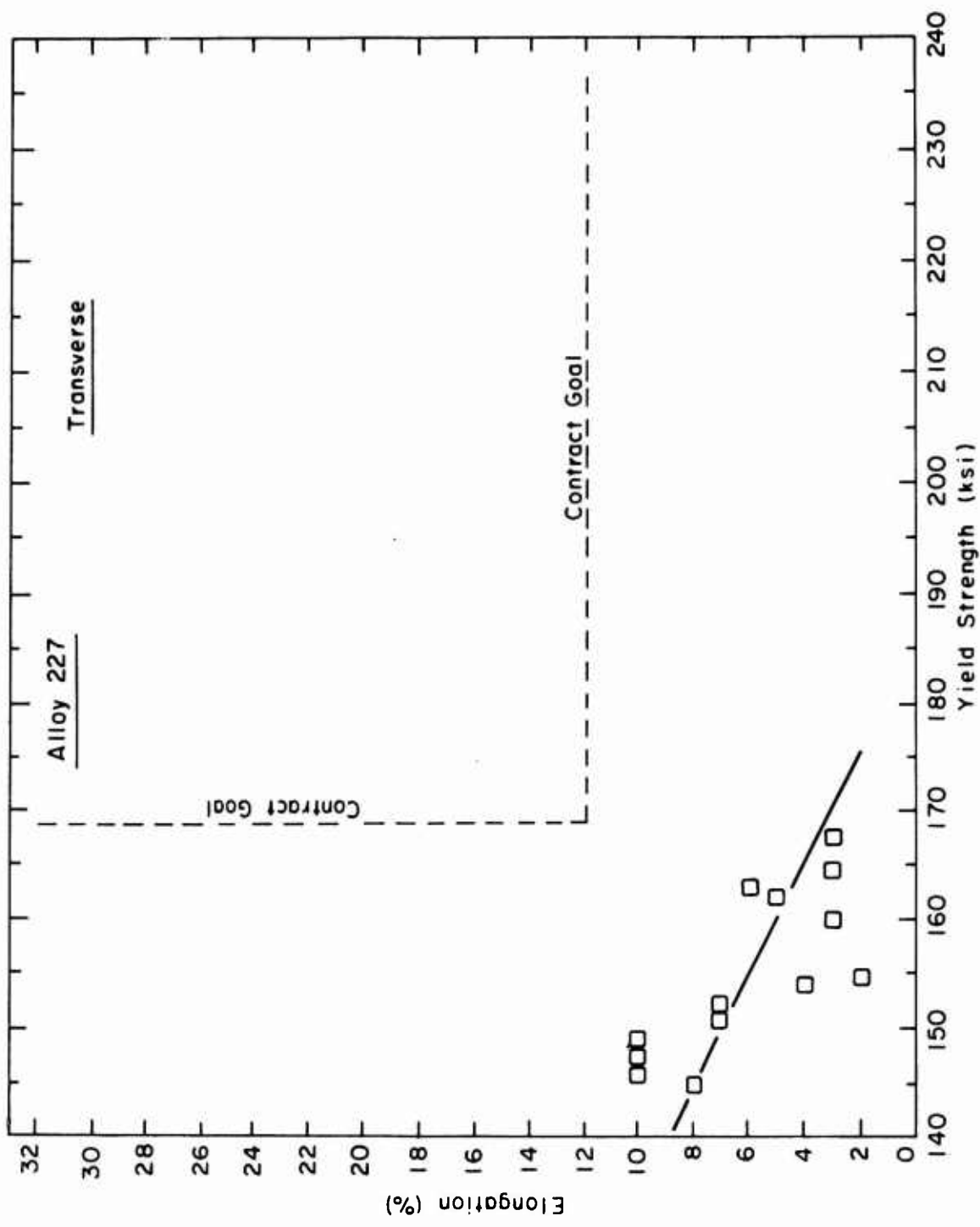

Figure 255. Alloy 227 (7Mo-4Cr-2.5Al). Transverse alloy characteristic elongation - Yield strength trend line for "optimum" heat-treatment.

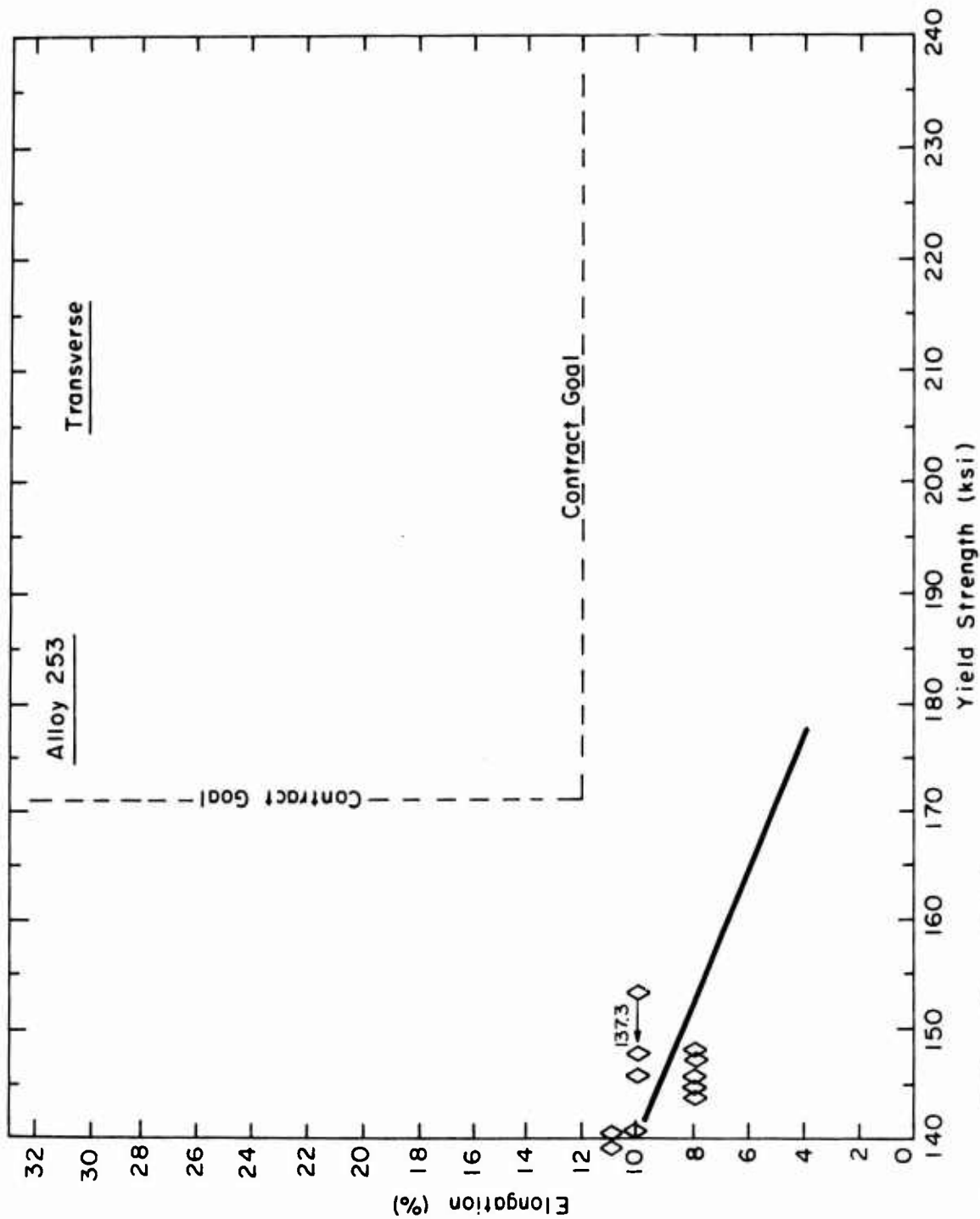

Figure 256. Alloy 253 (10Mo-8V-2.5Al). Transverse alloy characteristic elongation - Yield strength trend line for "optimum" heat-treatment.

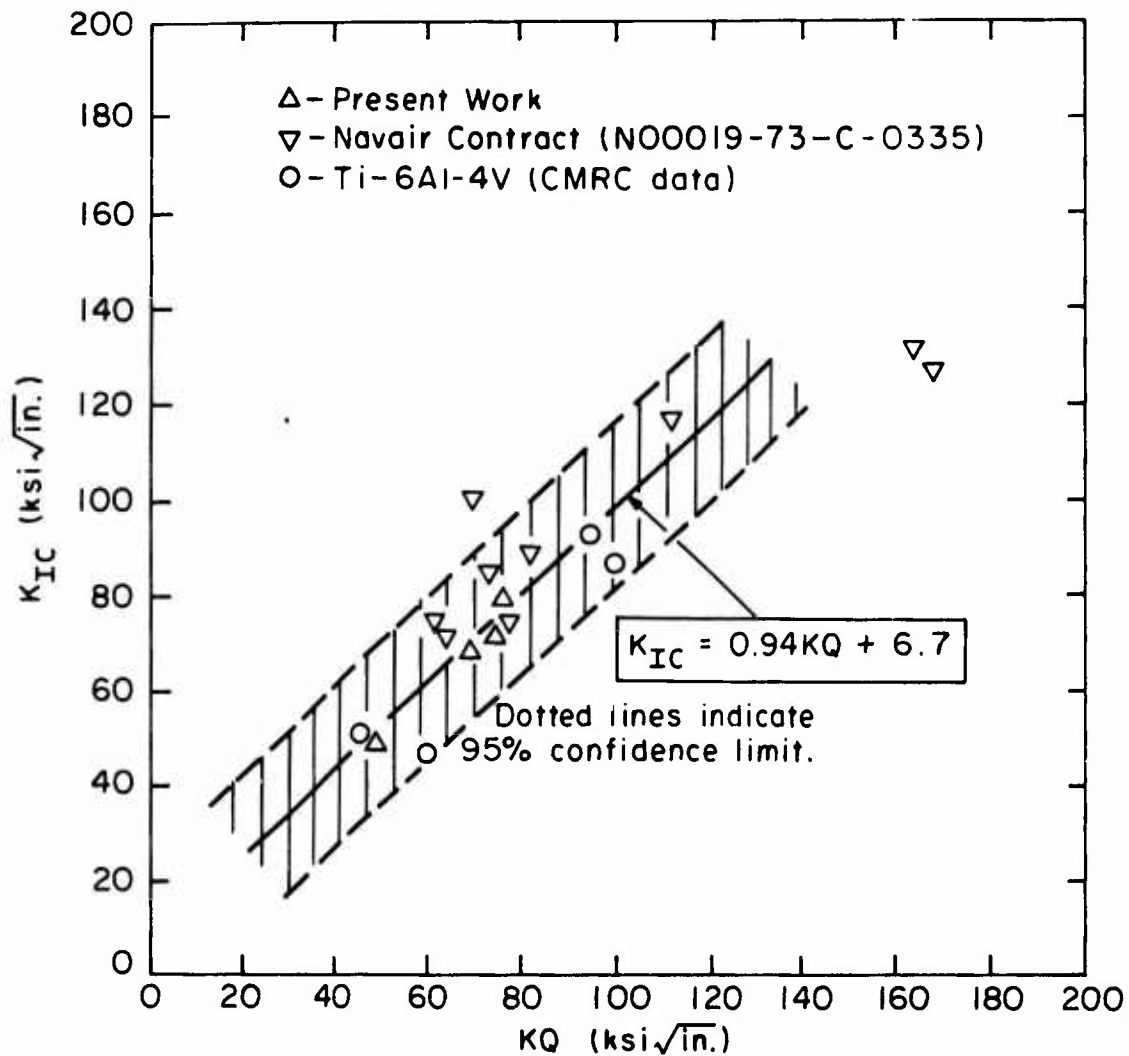

Figure 257. Relationship of K_{IC} to K_Q under present, contract and parallel investigations. (22,23)
 K_{IC} determined from valid test (see Appendix H),
 K_Q from slow bend pre-cracked Charpy samples.
 Each point is the average of at least two values for each parameter.

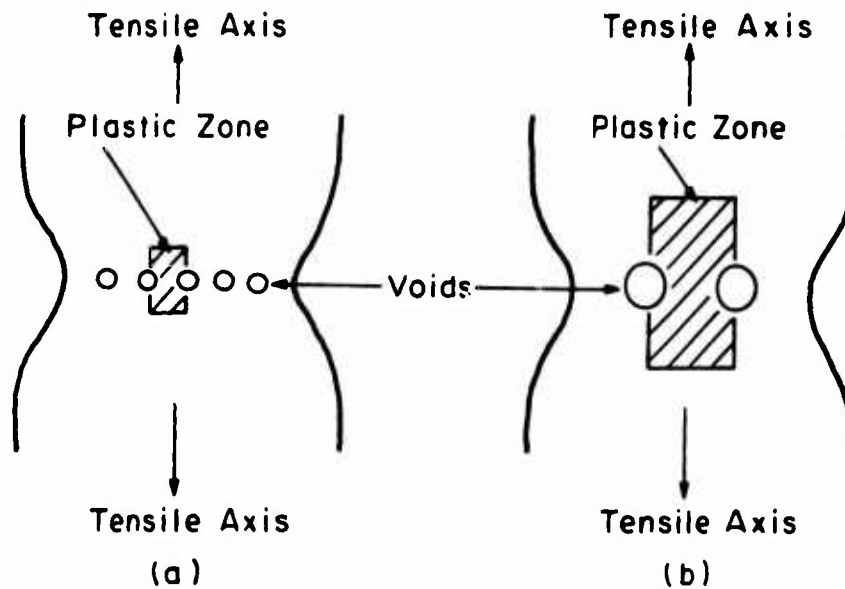

Figure 258. Schematic representation of void formation and associated plastically deformed zone as a result of applied tensile stress. The total plastic deformation with (a) many closely spaced voids is less than that with (b) few widely spaced voids, resulting in greater macroscopic ductility in the latter case.

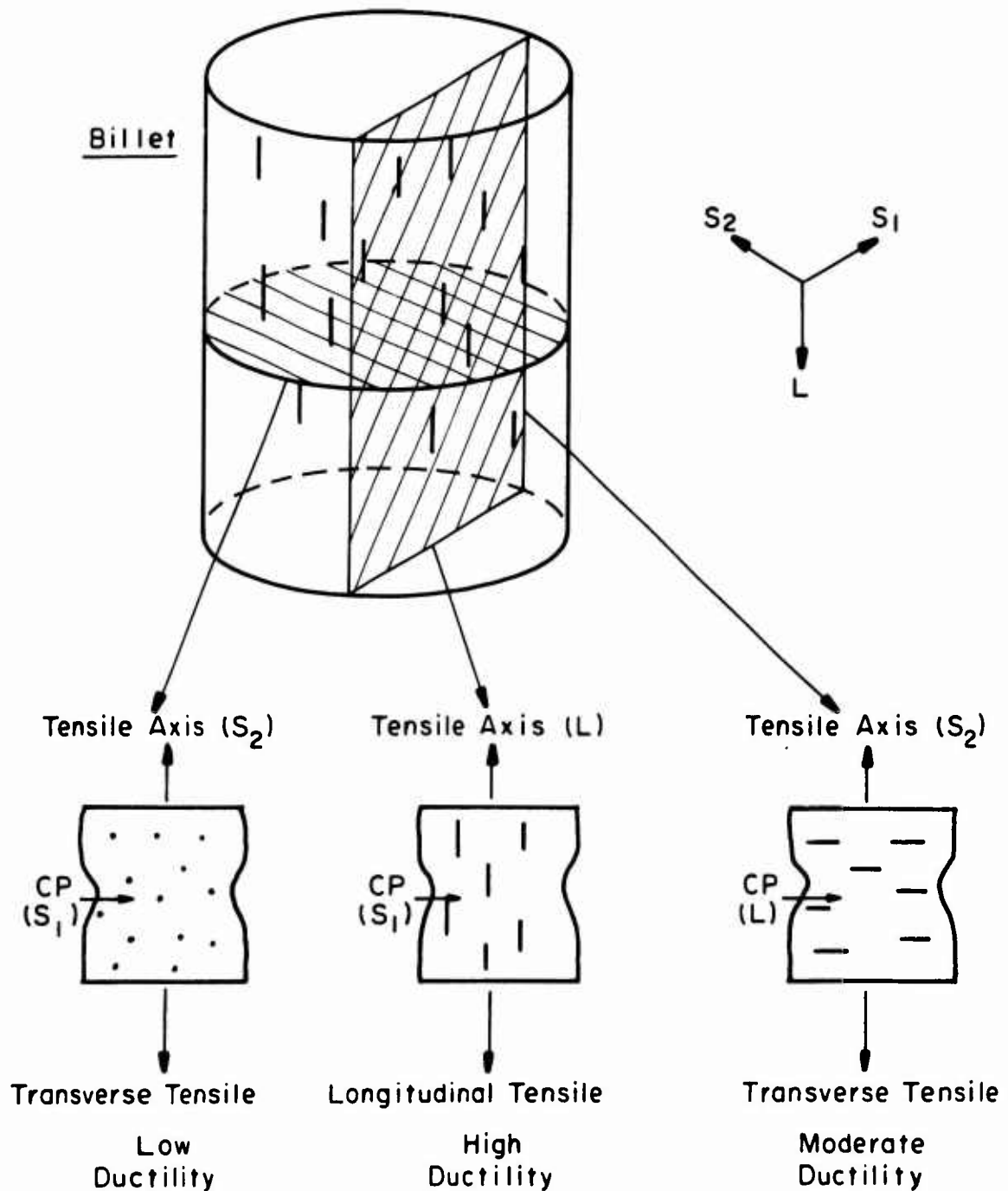

Figure 259. Schematic representation of relationship of ductility directionality to lenticular voids formed in a billet during tensile stress. CP is crack path extension direction. Longitudinal ductility is predicted to be significantly higher than transverse ductility.

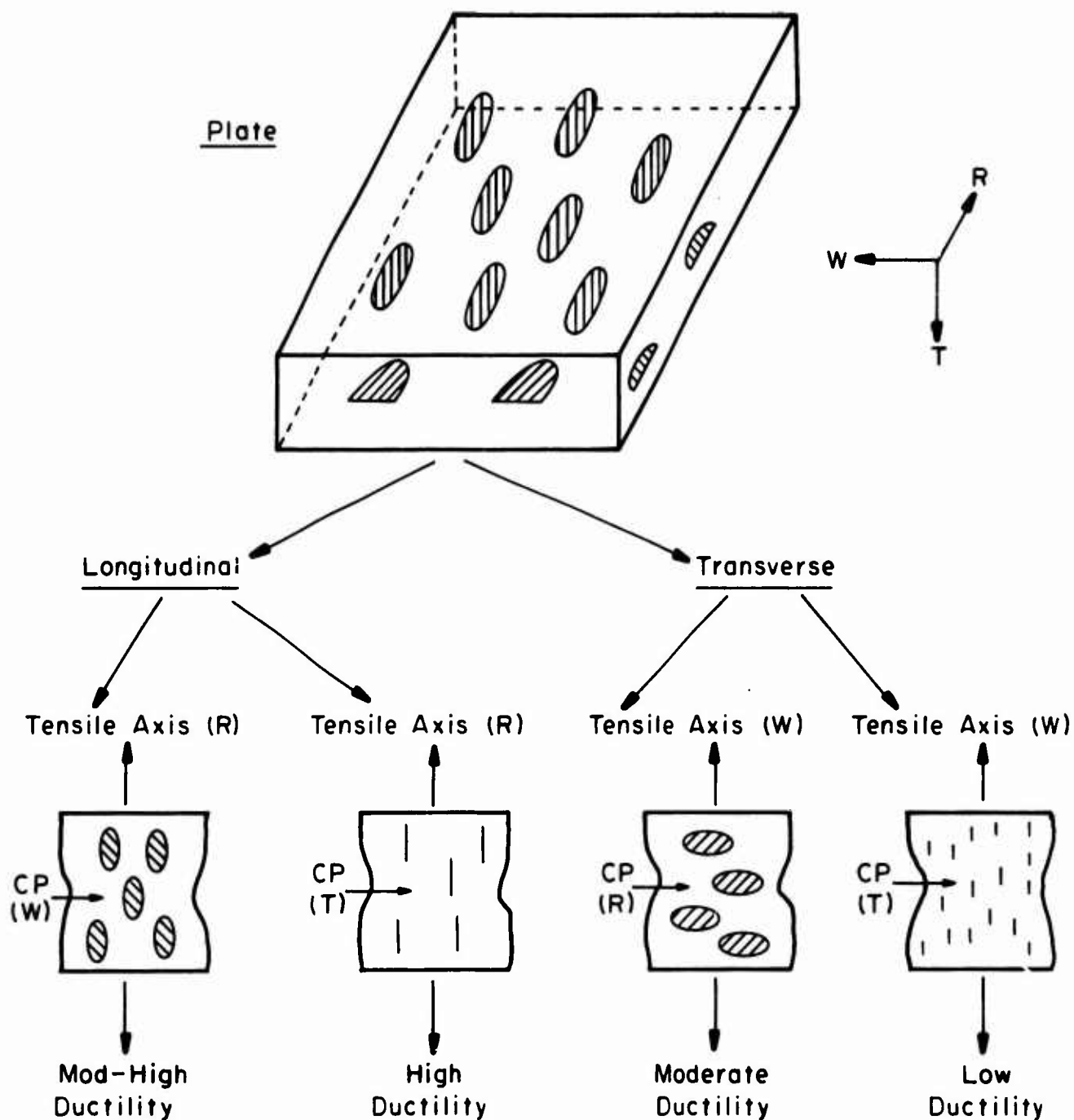
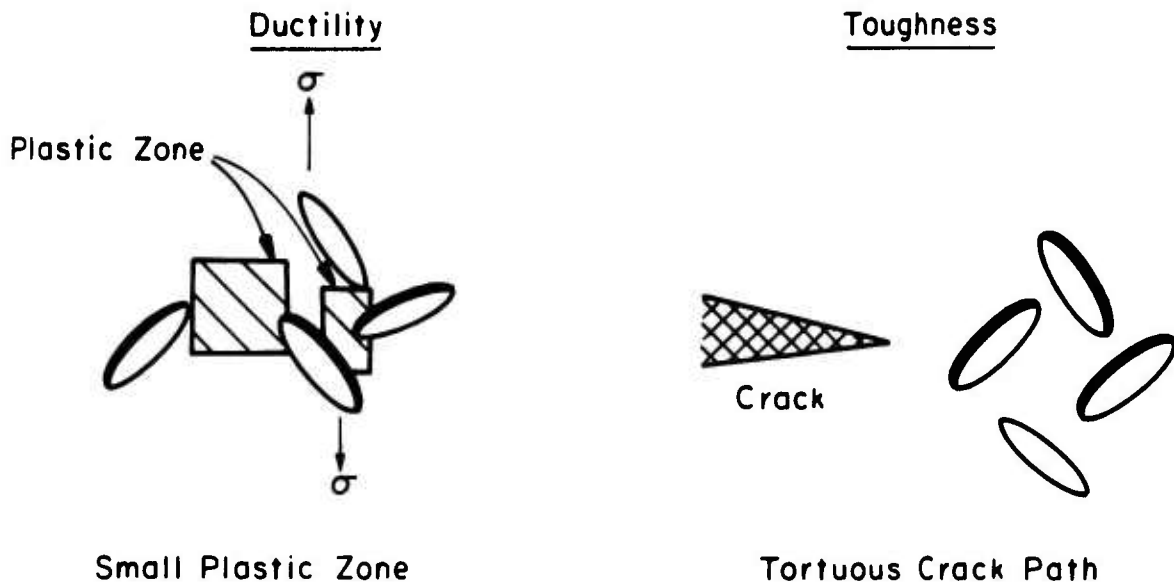

Figure 260. Schematic representation of relationship of ductility directionality to disc-like voids formed in plate during tensile stress. CP is crack path extension direction. Longitudinal ductility is predicted to be somewhat higher than transverse ductility.

Lenticular Coarse Alpha

Nucleation - Easy

Growth - Difficult



Globular Coarse Alpha

Nucleation - Difficult

Growth - Easy

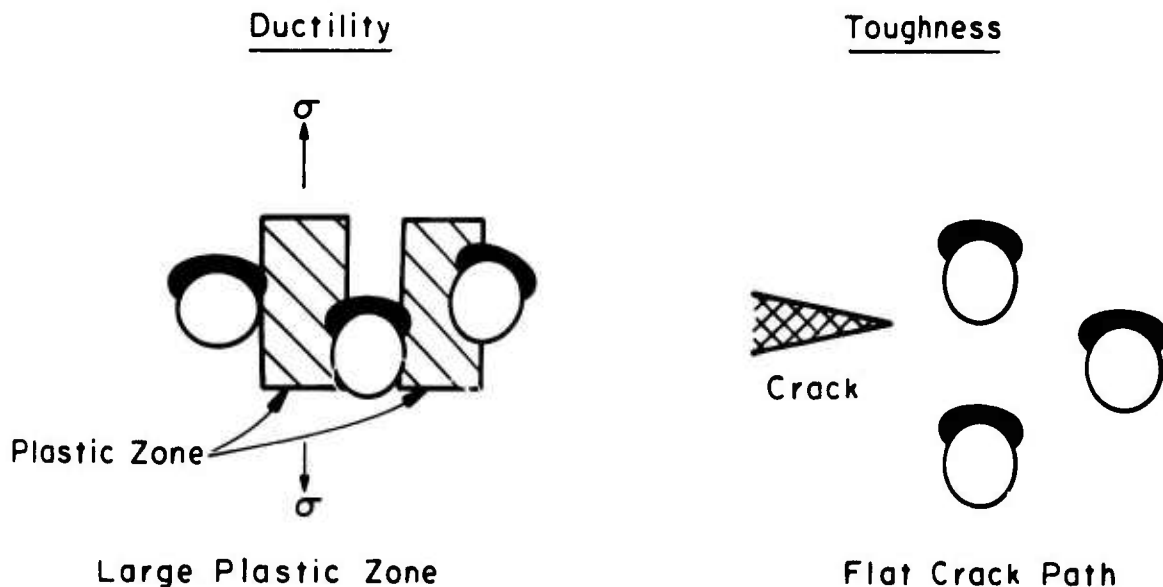

Figure 261. Schematic representation of effect of coarse alpha shape on ductility and toughness. For a given volume fraction of coarse alpha the total plastic zone is greater for globular alpha. However, for a propagating crack, the tortuosity factor for lenticular alpha overcomes this effect. Voids are shown as black regions.

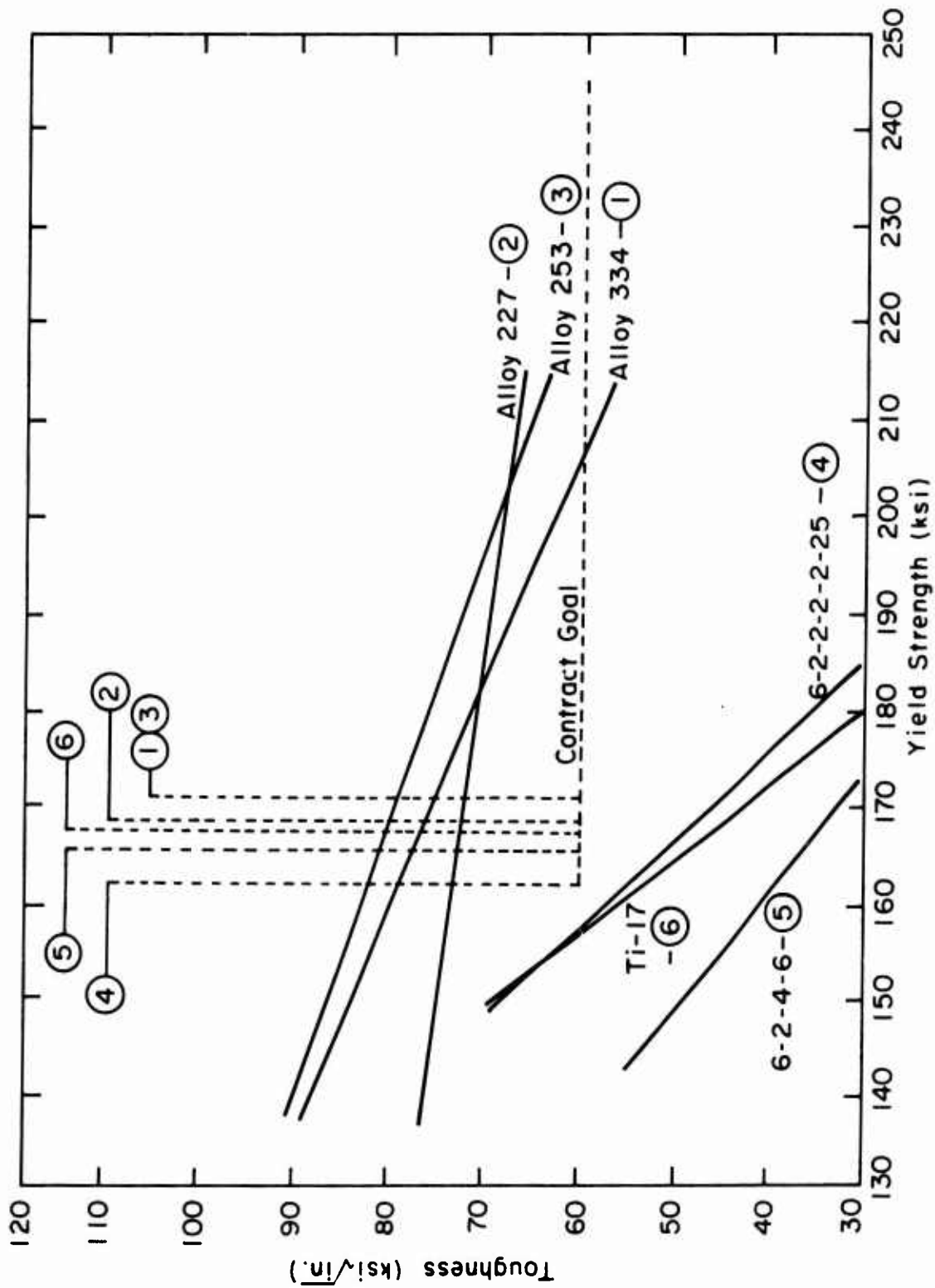

Figure 262 - Toughness-yield strength characteristic alloy trend lines for present contract alloys and experimental and semi-commercial deep hardenable alloys. Goal properties for each alloy are density normalized (number code above).

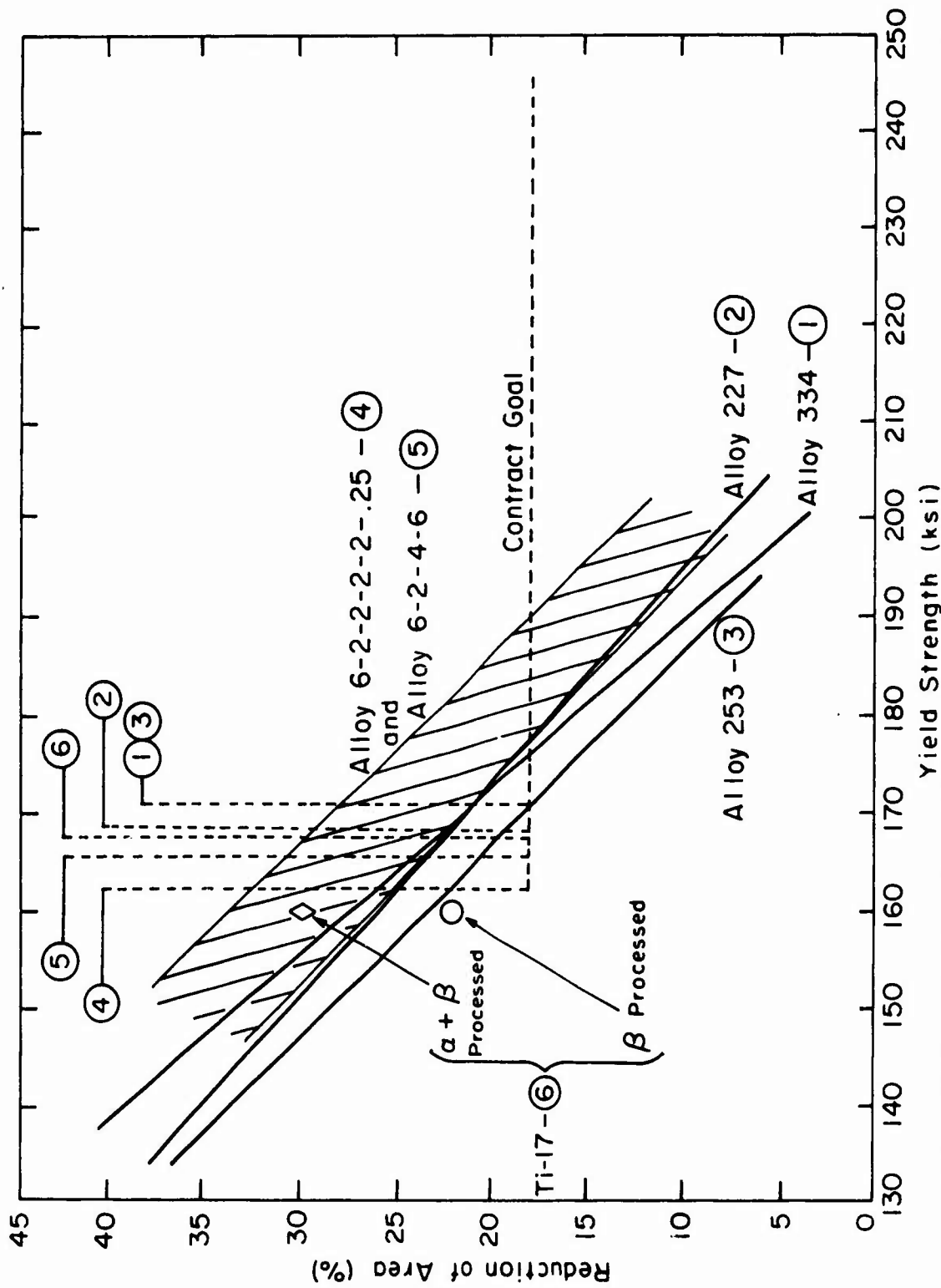

Figure 263 - Reduction of area-yield strength characteristic alloy trend lines for present contract alloys and experimental and semi-commercial deep hardenable alloys. Goal properties for each alloy are density normalized (number code above).

DISTRIBUTION

Jet Propulsion Lab
California Inst. of Tech
Attn Materials Research Sec
4800 Oak Grove Dr
Pasadena, CA 91103

Aerojet-General Corp.
Attn: Technical Library
P.O. Box 1947
Sacramento, CA 95809

Aerospace Industries Assoc.Inc.
Attn: Matls & Structures Com.
1725 Desales St. NW
Washington, DC 20036

Aerojet-General Corp.
Attn: Met. Engineering
Dept. 1184
11711 S. Woodruff Ave.
Downey, CA 92041

Aerojet-General Corp.
Attn: C. Hartbower
PHOH Box 1947
Sacramento, CA 95809

Aerojet-General Corp.
P.O. Box 296
Azusa, CA 91702

Aerospace Corp.
Attn: Library, Tech Rpts.
P.O. Box 95085
Los Angeles, CA 90045

AFOSR/NE
1400 Wilson Blvd.
Arlington, VA 22209

AFRPL/CNS
Edwards AFB, CA 93523

AF SC/DOL (DLSA)
Andrews AFB
Washington, DC 20331

AFSC/INA
Andrews AFB, MD 20334

Air University Library
Maxwell AFB, AL 36112

Allegheny Ludlum Steel Corp.
Research Center
Attn: P. Santoli

Allis-Chalmers Mfg. Co.
Defense Products Division
P.O. Box 512
Milwaukee, WI 53201

Aluminum Company of America
Alcoa Research Labs
Attn: Asst. Director of Rsch
P.O. Box 772
New Kensington, PA 15068

Aluminum Company of America
Attn: G.B.Barthold
1200 Rign Bldg.
Washington, DC 20036

Aluminum Co. of America
Attn: G.K.Turnbull
2210 Harvard Ave.
Cleveland, OH 44105

Armco Steel Corp.
Attn: Tech. Library
RSCH & Tech. Division
Middletown, OH 45042



DISTRIBUTION

cont.

Armco Steel Corp.
Armco Research Ctr.
Attn: J. L. Arnold
Middletown, OH 45042

Army Aviation Material Com.
AMSAV-X/Mr. L. Kiefer
P.O. Box 209
St. Louis, MO 63166

Army Matls Rsch Agency
AMXMR/D. Driscoll
Watertown, MA 02172

Army Mobility Equip. R&D Ctr.
Attn: E. Asher
Fort Belvoir, VA 22060

Army Production Equip. Agcy
Attn: Chief, Mfg. Tech. Div.
Rock Island Arsenal
Rock Island, IL 61202

Army Tank Autom. Command
SMOTA-RCPT/D. M. Latson
Warren, MI 48089

Avco Corp.
Lycoming Division
Attn: Dir./Matls Labs
550 S. Main St.
Stratford, CT 06497

Avco Corp.
Lycoming Division
Attn: Div. Library
550 S. Main St.
Stratford, CT 06497

Babcock & Wilcox Co.
Attn: R&D Division
Alliance, OH 44601

Battelle Memorial Inst.
Attn: Reports Library
505 King Ave.
Columbus, OH 43201

Battelle Memorial Inst.
Non-Ferrous Metallurgy Div.
505 King Ave.
Columbus, OH 43201

Battelle Northwest
Battelle Memorial Inst.
Pacific Northwest Lab
Attn: Technical Library
Richland, WA 99352

Bell Aerosystems Co.
Attn: Mgr/Advanced Mfg. Eng.
Internal Mail Zone C-53
P.O. Box 1
Buffalo, NY 14205

Bell Helicopter Co.
Attn: Mgr/Prod. Engineering
P.O. Box 482
Fort Worth, TX 76101

Bendix Corp.
Aerospace Division
Attn: Technical Librarian
717 N. Bnedix Dr.
South Bend, IN 46620

DISTRIBUTION

cont.

Boeing Company
Aerospace Division
Attn: Tech In [REDACTED]
P.O. Box 3707
Seattle, WA 98124

Boeing Co.
Attn: Technical Library
P.O. Box 707
Renton, WA 89055

Boeing Company
Commercial Airplane Div.
Technical Library
Mail Stop 74-60
Seattle, WA 98124

Boeing Company
Vertol Division
Technical Library
P.O. Box 16858
Philadelphia, PA 19142

Boeing Company
Wichita Division
Technical Library
3801 South Oliver
Wichita, KS 67210

Bundy Corp.
Attn: Larry Savage
Metallurgical Prod. Div.
P.O. Box 1312P
Warren, MI 48090

Bureau of Mines
Albany Met. Rsch Ctr.
Albany OR 97321

Cameron Iron Works, Inc.
Attn: J.W. Brougher
P.O. Box 1212
Houston, TX 77001

Cannon Muskegon Corp
Attn: S. Morykwas
2875 Lincoln St.
Muskegon, MI 49433

Canton Drop Forging & Mfg. Co.
Attn: C. Brauchler
2100 Wilett Ave.
Canton, OH 44701

Carpenter Steel Co.
Metallurgical Dept.
Reading, PA. 19603

Chief of Naval Material
Code NSP43
Navy Department
Washington, DC 20360

Chief of Naval Operations
Navy Department
Washington, DC 20330

Chief of Naval Rsch
Code ONR-740
Navy Department
Washington, DC 20360

Clevite Corp.
Attn: Library
540 E. 105th St.
Cleveland, OH 44108

Colorado School of Mines
Metallurgical Engr. Dept.
Golden, CO 80401

Colt Industries/Crucible Inc
Attn: E. Dulis
P.O. Box 88
Pittsburgh, Pa. 15230

DISTRIBUTION cont.

Commander
Naval Air Systems Command
Headquarters/Air-320
Washington, DC 20360

Commanding Officer
Naval Air Development Ctr.
Johnsville
Warminster, PA 18974

Commander
Naval Air Systems Command
Headquarters/Air-604
Washington, DC 20360

Commanding Officer
Watertown Arsenal
Attn: Technical Info Sec
Watertown, MA 02172

Commander
Naval Air Systems Command
Headquarters/Air-2052
Washington, DC 20360

Commanding Officer & Director
Naval Applied Sci Lab
Flushing & Washington Ave.
Brooklyn, NY 11251

Commander
Naval Air Systems Command
Headquarters/Air-5203
Washington, DC 20360

Curtiss-Wright Corporation
Metals Processing Division
Attn: Chief Engineer
760 Northland Ave.
Buffalo, NY 14215

Commander
Naval Ordnance Laboratory
Silver Springs, MD 20910

Curtiss-Wright Corp.
Wright Aeronautical Div.
Attn: R.J. Morgan, Mgr.
Wood-Ridge, NJ 07075

Commander
Naval Ordnance Test Station
Pasadena Annex
3202 E. Foothill Blvd.
Pasadena, CA 91107

Defense Documentation Center
Attn: DDC-TC (12 cys)
Cameron Station
Alexandria, VA 22314

Commander
Naval Ship R&D Center
Attn: R.L. Helferich
Annapolis, MD 21402

Denver Rsch Inst.
Metallurgy Division
University of Denver
Denver, CO 80210

Commander
Naval Weapons Laboratory
Dahlgren, VA 22448

Director
Naval RSCH Laboratory
Code 2020
Washington, DC 20390

Commanding Officer
Naval Air Dev. Ctr.
Johnsville
Warminster, PA 18974

Fairchild Hiller
Republic Aviation Div.
Attn: Tech. Library
Farmingdale, LI, NY 11735

DISTRIBUTION

cont.

Garrett Corp.
Airesearch Mfg. Division
Attn: Mtls & Process
9851 Sepulveda Blvd.
Los Angeles, CA 90009

Garrett Corporation
Airesearch Mfg. Div.
Attn: Library
P.O. Box 5217
Phoenix, AZ 85026

Garrett Corporation
Airesearch Mfg. Cor. of Arizona
Attn: Supv., Matls Engr.
402 S. 36th Street
Phoenix, AZ 85034

General Dynamics
Convair Division
Attn: Materials Rsch
P.O. Box 1128
San Diego, CA 92212

General Dynamics Corp.
Fort Worth Div.
Attn: Man Eng Tech Lib MZ6212
P.O. Box 748
Fort Worth, TX 76101

General Dynamics Corp.
Fort Worth Division
Attn: Structural Sci. Group
P.O. Box 748
Fort Worth, TX 76101

General Electric Co.
Matls & Proc. Tech. Labs
Attn: T. K. Redden
Cincinnati, OH 45215

General Electric Co.
Missile & Space Div.
Attn: Technical Library
P.O. Box 8555
Philadelphia, PA 19101

General Electric Co.
Technical Information Ctr.
Mail Drop N-32
Cincinnati, OH 45212

General Motors Corp.
Detroit Diesel Allison Div.
Attn: Dr. M. Merman
Indianapolis, IN 46206

General Motors Corp.
Detroit Diesel Allison Div.
Attn: S. Nichols
P.O. Box 894 Code T2B
Indianapolis, IN. 46206

Grumman Aircraft Engr. Corp.
Attn: Head Matls Rsch Group
Grumman Rsch Dept.
Bethpage, NY 11714

H. M. Harper Co.
Attn: Metals Division
Lehigh Ave at Oakton St.
Morton Grove, IL 60053

Handy & Harmon
Attn: C. D. Cove
Vice President, Rsch & Dev.
Bridgeport, CT 06601

HQ Army Material Command
AMCRD-RS-CM
Attn: P. R. Kosting
Washington, DC 20036

DISTRIBUTION

cont.

HQ USAF (AFRDPS)
The Pentagon Building
Washington, DC 20330

HQ USAF (SAFRD)
The Pentagon
Washington, DC 20330

HQ USAF/AFCSAT
Study Information Group
Asst. Chief of Staff for
Study and Analysis
Washington, DC 20330

HQ USAF/AFRSIC
Washington, DC 30220

HQ USAF/FASPOI
Attn: W. Martin
Pentagon Building
Washington, DC 20330

IIT Rsch Institute
Metals Rsch Division
10 West 35th St.
Chicago, IL 60616

International Harvester Co.
Solar Division
Attn: Dr. A.G. Metcalfe
2200 Pacific Ave.
San Diego, CA 92112

Ladish Co.
Attn: Library
Cudahy, WI 53110

Ladish Co.
Attn: R. P. Daykin
Asst. Vice President
Cudahy, WI 53110

Lockheed Missiles & Space Co.
Attn: Technical Info Ctr
3251 Hanover St.
Palo Alto, CA 94304

Lockheed-California Co.
Attn: Tech. Information Ctr.
P.O. Box 551
Burbank, CA 91503

Lockheed-California Co.
Materials Rsch Labs
Attn: Tech Info Ctr
P.O. Box 551
Burbank, CA 91503

LTV Corporation
Vought Aeronautics Div.
Attn: Library
P.O. Box 5907
Dallas, TX 75222

Marquardt Corp.
Attn: Librarian
16555 Saticoy St.
Van Nuys, CA 91409

Martin Co.
Attn: Library
Mfg. Rsch & Dev. M. 398
Baltimore, MD 21203

Martin Marietta Corp.
Denver Division
Attn: R. F. Breyer
P.O. Box 179
Denver, CO 80202

Martin Marietta Corp.
Martin Metals Division
Attn: W. D. Rowland
250 N. Twelfth St.
Wheeling, IL 60090

DISTRIBUTION

cont.

Materials Division
Office of Asst. Director
OSD DDR&E
Washington, DC 20301

NASA
Attn: R. H. Raring
DUZ-7026, Code RRM
Washington, DC 20036

McDonnell Douglas Corp.
A3-328 Tech Library Services
Huntington Beach CA 92647

NASA
Lewis Rsch Ctr
Attn: Library Mail Stop 3-7
21000 Brookpark Rd.
Cleveland, OH 44135

McDonnell Douglas Corp.
Attn: Engineering Library
2000 N. Memory Drive
Tulsa, OK 74115

NASA-Lewis Rsch Ctr.
Attn: W. R. Brown, Jr.
Mail Stop 105-1
21000 Brookpark Rd.
Cleveland, OH 44135

McDonnell Douglas Corp.
Attn: Harrison Turner
P.O. Box 516
St. Louis, MO 63166

National Academy of Science
National Rsch Council
Attn: Dr. J. Lane
2101 Constitution Ave.
Washington, DC 20037

McDonnell Douglas Corp.
Attn: Library
3855 Lakewood Blvd.
Long Beach, CA 90801

National Bureau of Standards
Attn: G. A. Moore
Washington, DC 20234

McDonnell Douglas Corp
Missiles & Space Systems Div.
Attn: R&D Library
3000 Ocean Park Blvd
Santa Monica, CA 90405

Naval Plant Representative
Applied Physics Lab
Johns Hopkins University
8621 Georgia Ave.
Silver Spring, MD 20910

Mechanical Properties Data Ctr
13919 West Bay Shore Drive
Traverse City, MI 49684

New York University
Rsch Building 1
177th St. & Cedar Ave.
Bronx, NY 10453

MI Iron Rsch & Dev Corp.
Attn: Dr. R. Rosenberg
899 Main St.
Waltham, MA 02154

Mr. R. T. Schwartz
2185 Broadbent Way
Kettering, OH 45440

North American Rockwell Corp.
Attn: N. Klimmek, Mgr.
International Airport
Los Angeles, CA 90009

DISTRIBUTION

cont.

North American Rockwell Corp.
Los Angeles Division
Attn: Library - Dept. 56
International Airport
Los Angeles, CA 90009

Northrop Corporation
Aircraft Division
Attn: Tech Info Unit
3901 W. Broadway
Hawthorne, CA 90250

Numec Corporation
Attn: Supv, Reactive Metals
Apollo, PA 15613

Oak Ridge National Lab
Metals & Ceramics Division
Attn: W. R. Martin
P.O. Box X
Oak Ridge, TE 37830

Oregon Metallurgical Corp
Attn: Metallurgical Dev
P.O. Box 580
Albany, OR 97321

Philco-Ford Corp.
Aeronautic Division
Attn: Tech Info Service
Ford Road
Newport Beach, CA 92663

Polymet Corporation
10597 Chester Road
Cincinnati, OH 45215

REM Metals Corp.
Attn: J. R. Humphrey
P.O. Box 829
Albany, OR 97321

Republic Steel Corp.
Republic Rsch Ctr Library
6801 Brecksville Rd
Cleveland, OH 44131

RMI, Inc.
Attn: Technical Director
Niles, OH 44446

Rocketdyne Division
Rockwell International
Attn: Dr. W.T. Chandler
6633 Canoga Park Ave
Canoga Park, CA 91303

Rockwell International
Attn: Dr. N. Paton
Science Center
Thousand Oaks, CA 91360

Rockwell International
Attn: LAD Library, Dept. 262
International Airport
Los Angeles, CA 90009

Rohr Industries, Inc
Attn: F.E.Zimmerman, Mgr.
P.O. Box 878
Chula Vista, CA 92012

Ryan Aeronautical Co.
Materials & Processes Lab
Attn: Chief Metallurgist
Lindberg Field
San Diego, CA 92110

SAMOS/SMT
P.O. Box 92960
Worldway Postal Ctr
Los Angeles, CA 90009

DISTRIBUTION

cont.

SAMSO/SMKIP
P.O. Box 92960
Worldway Postal Ctr
Los Angeles, CA 90009

SAMSO/SMT AFML
P.O. Box 92960
Worldway Postal Ctr
Los Angeles, CA 90009

SAMSO/SY-AFML
P.O. Box 92960
Worldway Postal Ctr
Los Angeles, CA 90009

Sandia Corporation
Attn: Tech Library/3421
P.O. Box 5800
Albuquerque, NM 87115

Sandia Laboratories
Attn: Dir of Mtls & Proc/5500
P.O. Box 5800
Albuquerque, NM 87115

Southern Rsch Institute
Metallurgy Division
2000 Ninth Avenue
Birmingham, AL 35203

Stanford Rsch Inst.
Attn: G-037 External Rpts.
Menlo Park, CA 94025

Sylvania Inc.
Chemical & Metallurgical Div.
Towanda, PA 18848

Technical Center
Attn: VP & Tech. Director
Gas Turbine Components Group
699 Benston Rd.
Whitehall, MI 49461

Teledyne Titanium
P.O. Box 1189
Monroe, NC 28110

TRW Inc
Attn: Dr. E.A. Steigerwald
23555 Euclid Avenue
Cleveland, OH 44117

TRW Inc.
Equipment Labs
Attn: J.N. McCarthy
23555 Euclid Avenue
Cleveland, OH 44117

Union Carbide Metals Co.
Attn: Tech Dept. Library
4625 Royal Avenue
P.O. Box 580
Niagara Falls, NY 14300

United Aircraft Corp.
Pratt & Whitney Aircraft Div.
Attn: D. Ruckle
E. Hartford, CT 06108

United Aircraft Corp.
Pratt & Whitney Aircraft Div.
Attn: E. F. Bradley
E. Hartford, CT 06108

United Aircraft Corp.
Pratt & Whitney Aircraft Div.
Attn: M. Allen
P.O. Box 2691
West Palm Beach FL 33402

University of Kentucky
Dept. of Metallurgical Engr.
Attn: Dr. H. Conrad
Limestone Campus
Lexington, KY 40506

DISTRIBUTION

cont.

Watertown Arsenal
Attn: Dr. R. Weigle
Watervliet, NY 12139

Watertown Arsenal
Attn: S. V. Arnold
Army Matls Rsch Ctr
Watertown, MA 02170

Westinghouse Electric Corp
Rsch & Dev. Center
Attn: C.S.Cook
Churchill Borough
Pittsburgh, PA 15245

Wyman-Gordon Company
Attn: J. Coyne
Rsch & Development
Worcester, MA 01601

Wyman-Gordon Company
Attn: J. A. Rossow
Reseach & Development
Harvey, IL 60426

AF SC/INA
Andrews Air Force Base
Washington, DC 20331

Air University Library
Maxwell AFB, Alabama 36112

Defense Documentation Center
Attn: DDC-TC
Cameron Station
Alexandria, VA 22314

HOS USAF
Attn: AFRDPS-1 Lt.Col.T.C.Ferguson
Pentagon
Washington, DC 20330

Naval Postgraduate School, Code 59
Attn: Matls Science Group
Mechanical Engineering
Monterey, CA 93940