

USAARL Report 76-7

BIO-OPTICAL EVALUATION OF SPECIALIZED EYEWEAR:
LASER SAFETY AND DARK ADAPTATION DEVICES

By

Wun C. Chiou, Ph.D.

and

MAJ David D. Glick, O.D.

November 1975

Final Report

US Army Aeromedical Research Laboratory
Fort Rucker, Alabama 36362

This document has been approved for public release and sale; its
distribution is unlimited.



NOTICE

Qualified requesters may obtain copies from the Defense Documentation Center (DDC), Cameron Station, Alexandria, Virginia. Orders will be expedited if placed through the librarian or other person designated to request documents from DDC (Formerly ASTIA).

Change of Address

Organization receiving reports from the US Army Aeromedical Research Laboratory on automatic mailing lists should confirm correct address when corresponding about laboratory reports.

Disposition

Destroy this report when it is no longer needed. Do not return it to the originator.

Disclaimer

The findings in this report are not to be construed as an official Department of the Army position unless so designated by other authorized documents.

UNCLASSIFIED

SECURITY CLASSIFICATION OF THIS PAGE (When Data Entered)

REPORT DOCUMENTATION PAGE		READ INSTRUCTIONS BEFORE COMPLETING FORM
1. REPORT NUMBER 76-7	2. GOVT ACCESSION NO.	3. RECIPIENT'S CATALOG NUMBER
4. TITLE (and Subtitle) BIO-OPTICAL EVALUATION OF SPECIALIZED EYEWEAR: LASER SAFETY AND DARK ADAPTATION DEVICES		5. TYPE OF REPORT & PERIOD COVERED Final
		6. PERFORMING ORG. REPORT NUMBER
7. AUTHOR(s) Wun C. Chiou, Ph.D. MAJ David D. Glick, O.D.		8. CONTRACT OR GRANT NUMBER(s)
9. PERFORMING ORGANIZATION NAME AND ADDRESS Bio-Optics Division (SGRD-UAO) US Army Aeromedical Research Laboratory Fort Rucker, Al 36362		10. PROGRAM ELEMENT, PROJECT, TASK AREA & WORK UNIT NUMBERS DA Form 1498
11. CONTROLLING OFFICE NAME AND ADDRESS US Army Aeromedical Research Laboratory SGRD-UAC Fort Rucker, Al 36362		12. REPORT DATE November 1975
		13. NUMBER OF PAGES 29
14. MONITORING AGENCY NAME & ADDRESS (if different from Controlling Office) US Army Medical R & D Command Washington, D.C.		15. SECURITY CLASS. (of this report) Unclassified
		15a. DECLASSIFICATION/DOWNGRADING SCHEDULE
16. DISTRIBUTION STATEMENT (of this Report) This document has been approved for public release and sale; its distribution is unlimited.		
17. DISTRIBUTION STATEMENT (of the abstract entered in Block 20, if different from Report)		
18. SUPPLEMENTARY NOTES		
19. KEY WORDS (Continue on reverse side if necessary and identify by block number) Spectral transmittance Laser safety goggles Dark adaptation device Color vision test		
20. ABSTRACT (Continue on reverse side if necessary and identify by block number) This report provides quantitative data and color vision evaluations for several types of goggles. The first two types are laser safety devices and the other three are for dark adaptation purposes. It is found that He-Ne laser safety eyewear conforms to the Army Regulation specification. It is recommended that one type of the safety device be used for only one specific purpose. Furthermore, the laser safety device cannot be used when a detection of a red display or a red light source is required. Results from the dark adaptation devices show that the spectral transmission characteristics possess		

UNCLASSIFIED

SECURITY CLASSIFICATION OF THIS PAGE(When Data Entered)

virtually a common distribution.

UNCLASSIFIED

SECURITY CLASSIFICATION OF THIS PAGE(When Data Entered)

SUMMARY

This report provides quantitative data and color vision evaluation for several types of goggles. The first two types are laser safety devices and the other three are for dark adaptation purposes. It is found that He-Ne laser safety eyewear conforms to the Army Regulation specification. It is recommended that one type of the safety device be used for only one specific purpose. Furthermore, the laser safety device cannot be used when a detection of a red display or a red light source is required. Results from the dark adaptation devices show that the spectral transmission characteristics possess virtually a common distribution.

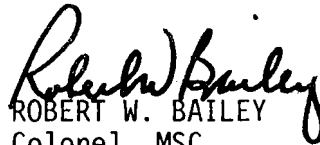
ROBERT W. BAILEY
Colonel, MSC
Commanding

INTRODUCTION

Although several references^{1,2,3,4} for establishing laser safety criteria are known, the optical characteristics and the spectral transmittances of the laser safety devices are unavailable in any published form. Since the underlying laser damaging mechanisms and thresholds to the visual system remain unresolved^{5,6} and since the laser radiation powers and intensities vary greatly with respect to the lasing materials and durations, there exists no universal safety device the optical quality of which will meet all the recent Army safety standards and regulations (AR 40-46)⁷.

The increasing use of lasers as military electro-optical research tools, range finders, target designators, and weapons promptly demands stringent safety protection for the users.

A qualitative evaluation of laser protective eyewear has been conducted previously⁸. Test results showed that exposure of laser goggle materials to sufficiently high laser energy would cause damage in the form of melting, bleaching, bubbling or shattering. Furthermore, some eye-safety products would fail to function as protective devices after only several seconds of exposure to laser beams of about 12 w/cm^2 . Nevertheless, no quantitative analysis of the optical quality of the devices has ever been provided. The purpose of this study is to evaluate two commercial safety goggles (Fig. 1) and to quantitatively compare their spectral transmission characteristics. Similar information is also provided for three red filters (Fig. 2) in use as dark adaptation devices. We believe that the data presented in this study are not available elsewhere, although fitting characteristics, field of view and effects upon color vision for one of the laser goggles have been previously investigated in this laboratory⁹. Results from this study will enable the users to calculate the amount of energy being transmitted through the safety devices. Several examples of the computations will be given to illustrate the application of the safety factor analysis.

METHOD

Devices Tested - The two types of laser safety devices used in this study were denoted as follow: (1) Type I device, manufactured by Omnitech Inc., Southbridge, MA 01560, was designed for protection against He-Ne lasers with power less than 1 mw. (2) Type II device, made by American Optical Corporation, Buffalo, NY 14215, was for use with ruby, neodymium or Ga-As lasers at 10^{-2} j/cm^2 energy density or less¹⁰. The frame for the type I device was a goggle and for the type

II device, a spectacle. The three red, dark adaptation devices used here were (1) WW II aviator's goggles, (2) Navy dark adaptation goggles and (3) fluorescopy adaptation goggles. The first was manufactured by Polaroid Corporation, Cambridge, MA and the second as well as the third were made by American Optical Corporation.

Apparatus - The two light sources used were (1) Macbeth daylight filter with 100 watt GE tungsten bulb, (2) 0.5 mW He-Ne laser made by CW Radiation Inc., Mountain View, California. The automatic data acquisition/analysis system had the following main components: (1) RSS (rapid scan spectrometer), (2) DPO (digital processing oscilloscope) with 4K storage memory. (Both are made by Tektronix Inc., Beaverton, Oregon.) and (3) PDP 11/05 with 24K memory and a cassette I/O drive. Tektronix 4010-1 TTY and 4610 hardcopier were the accessories to the system.

Experimental Design and Procedure

Figure 3 shows the experimental arrangement. The light source (either coherent or incoherent source) was on the optical axis of the RSS and the distance between them was 20 cm. The device to be tested was placed between the RSS and the light source. Other units were electronically connected with the RSS as schematically shown in the figure.

Two separate experimental procedures were used. The first procedure was to measure the spectral transmittance (ST) of each device. The basic technique was described in detail elsewhere¹¹. Briefly, the measurement process involved the division of the spectral power spectra with/without the device in the optical axis. Of course, each continuous spectrum had been digitized in the DPO and the computation processes were done in the PDP 11/05 through the control of several computer programs stored in the memory.

The second procedure was to obtain the ST after the laser safety devices were continuously exposed to the laser for durations of 5 and 10 minutes respectively. It enabled us to evaluate the reliability of the devices. The data acquisition and analysis were the same as those of the first procedure.

RESULTS

Figure 4 is the power spectrum of He-Ne laser. The ordinates are the relative energy with 20 nw/div and the abscissa are the wavelengths from 400 to 800 nm with 40 nm/div. The optical dispersion of the coherent source is about 10 nm centered at 632.8 nm. Figure 5

is the 1931 CIE chromaticity diagram of the laser. The X, Y and Z chromaticity coordinate values are 0.6933, 0.3067 and 7×10^{-7} respectively. It is noticed that the arrow is located at the edge of the diagram, indicating the source location plotted on the CIE diagram.

The upper curve in Figure 6 is the power spectrum of the Macbeth daylight lamp (incoherent light source). The middle curve is the power spectrum when the testing device is on the optical axis. The bottom curve is the background ambient light power spectrum when the light source is off. The abscissa and ordinates are similar to those in Figure 4 except the ordinate scale is 50 nw/div.

Results of ST curves for the two types of laser safety goggles are shown in Figures 7 and 10 respectively. The ST curves for the three types of adaptation goggles are presented in Figures 12, 13 and 14. Since the attenuation factor is in the order of thousands, the ST curve is usually nonsmoothed. However, at this point, a computer program is utilized to smooth the curve. (This computer program is attached in the appendix.). Figure 8 shows the smooth curve of Figure 7. Figures 9 and 11 are the CIE chromaticity diagrams of type I and II goggles respectively. The chromaticity coordinate values are shown at the upper portion of the graph. The arrow in each figure indicates that the color of the devices falls in the green region. The latter is the more saturated of the two.

Figure 15 summarizes the ST curves of all the dark adaptation goggles. It is interesting to note that they have the same general shape although the WW II goggles were made about three decades before the other two goggles. The chromaticity coordinate values are shown on the bottom of each figure. The scale in the ordinates is 1 nw/div and the abscissa is the wavelength from 400 to 800 nm with 40 nm/div. The same abscissa also applies to the last three figures.

The scale of the ordinate in Figures 16, 17 and 18 is 100 pw/div. All of these figures contain smoothed curves. The ST curves for 5 and 10 minutes are respectively shown in Figures 16 and 17. Figure 18 gives the comparison between them. It is noted that the curves are almost identical. We used the type I device for this portion of the experiment since we had only the He-Ne laser. Also, we did not use the average ST as we did in our previous studies^{11,12} simply because the ST in this study is not uniform across the spectral range.

DISCUSSION AND CONCLUSION

Army Regulation 40-46 specifies that the protection standard for intrabeam viewing by the eye for the continuous wave (CW), He-Ne laser is 2.5 mw.cm^{-2} at 0.25 second exposure duration and is $1 \mu\text{W cm}^{-2}$ at

4 to 8 hours in the use of optical alignment⁷. The laser beam diameter used in the study is approximately 1.2 mm. The mean laser energy passed through the protective devices after 10 minute exposure is in the order of 5×10^{-7} w. Thus the radiation density penetrated through the protective device is $0.44 \times 10^{-1} \text{ mwcm}^{-2}$ which is lower than that of the specified standard (2.5 mw.cm^{-2}). The amount of energy penetrated through a linear optical medium is in general proportional to the power of the laser. This implies that a 60 mw or more He-Ne laser will exceed the specified hazardous standard of 2.5 mw cm^{-2} at an exposure duration only one quarter of a second (assuming that the beam diameter is still 1.2 mm). Since the type I goggles are made for the use of low power laser protective devices, the present analysis shows that it is within the specified AR safety range.

Caution has to be taken when detection and/or viewing of a red display or object is required. Since the devices transmit virtually no light beyond 560 nm, any light source beyond the yellow-red region will not be seen. The exact opposite situation occurs for the three types of dark-adaptation goggles. They transmit light beyond 560 nm. In addition, the authors wore the Type I and II laser safety goggles for one and a half hours and tested their color vision with the Nagel-Schmidt Anomaloscope after 5, 15, 45, 60 and 90 minutes of wearing time and found no significant changes from their pre-wearing results. The goggles were removed only during the short period required to give the test. Post wearing results were also unaffected. It was found, however, that the type II goggle has a more severe effect on color vision while being worn than the Type I. This was noted with the American-Optical Hardy, Rand, Rittler color vision test.

In summary, this study has provided quantitative data for several types of goggles. The first two types of safety devices are made for laser protection and the other three types are for dark adaptation purposes. It is found that the He-Ne laser safety goggles are adequate in terms of the Army Regulation specification. Results from the other three types show that the spectral transmission characteristics possess virtually a common shape. It is recommended that one type of the safety device be used for only one specific purpose. Furthermore, the laser safety device cannot be used when a detection of a red display or light source is required. A computer program for smoothing the "noisy" spectral curve has also been developed.

LITERATURE CITED

1. Vassiliadis, A.; Sweng, H.C.; Peppers, N.A. and Peabody, R.R., "Thresholds of laser eye hazards," Arch Environ. Health, 20: 161-170, 1970.
2. Sliney, D.A. and Freasier, B.C., "Evaluation of optical radiation hazards," Applied Optics, 12: 1-24, 1973.
3. Sliney, D.H.; Bason, F.C. and Freasier, B.C., "Instruments and measurement of ultraviolet, visible and infrared radiation," Am. Industrial Hygiene Association Journal, 32: 415-430, 1971.
4. Sliney, D.H., "Laser safety update - an LIA report," Electro-Optical System Design, Nov.: 28-30, 1974.
5. Ham, W.T., Jr.; Miller, H.A.; Goldman, A.I.; Newnam, B.E.; Holland, L.M.; and Kuwabara, T., "Ocular hazard from picosecond pulse of Nd:YAG laser radiation," Science, 185; 362-363, 1974.
6. Tabouda, J. and Ebberts, R.W., "Ocular tissue damage due to ultrashort 1060-nm light pulses from a mode-locked ND: glass laser," Applied Optics, 14: 1759-1761, 1975.
7. Army Regulation 40-46, "Medical service - control of health hazards from lasers and other high intensity optical sources," TAGO 405A-Jan. 540-471-74.
8. Elder, R.L., "Laser protective eyewear," Applied Optics, 13: 725, 1974.
9. Crosley, J.K.; Laychak, L.J. and Braun, E.G., "An evaluation of anti-laser goggles," USAARL-LR-73-1-2-1, 1972.
10. Units to specify the laser can be in terms of watt-power output or amount of energy concentration at a certain confined area. The use of the former determines the total amount of the laser delivering energy available and the latter is for the laser receiving energy available.
11. Chiou, W.C., "Visible spectral transmission characteristics of windscreens in Army aircraft," USAARL-LR-75-29-7-8, 1975.
12. Chiou, W.C., "Infrared spectral transmission characteristics of windscreens in Army aircraft," USAARL-LR-76-2-7-2, 1975.

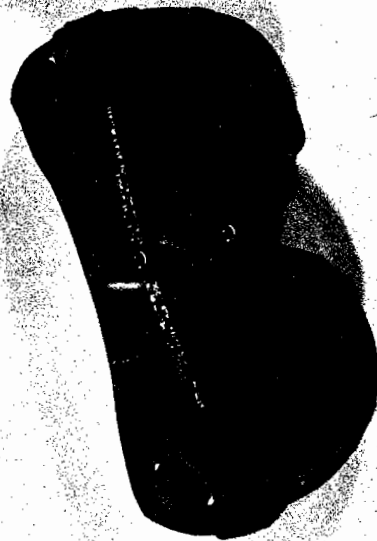

TYPE 1



TYPE 2

LASER SAFETY EYEWEAR

FIGURE 1

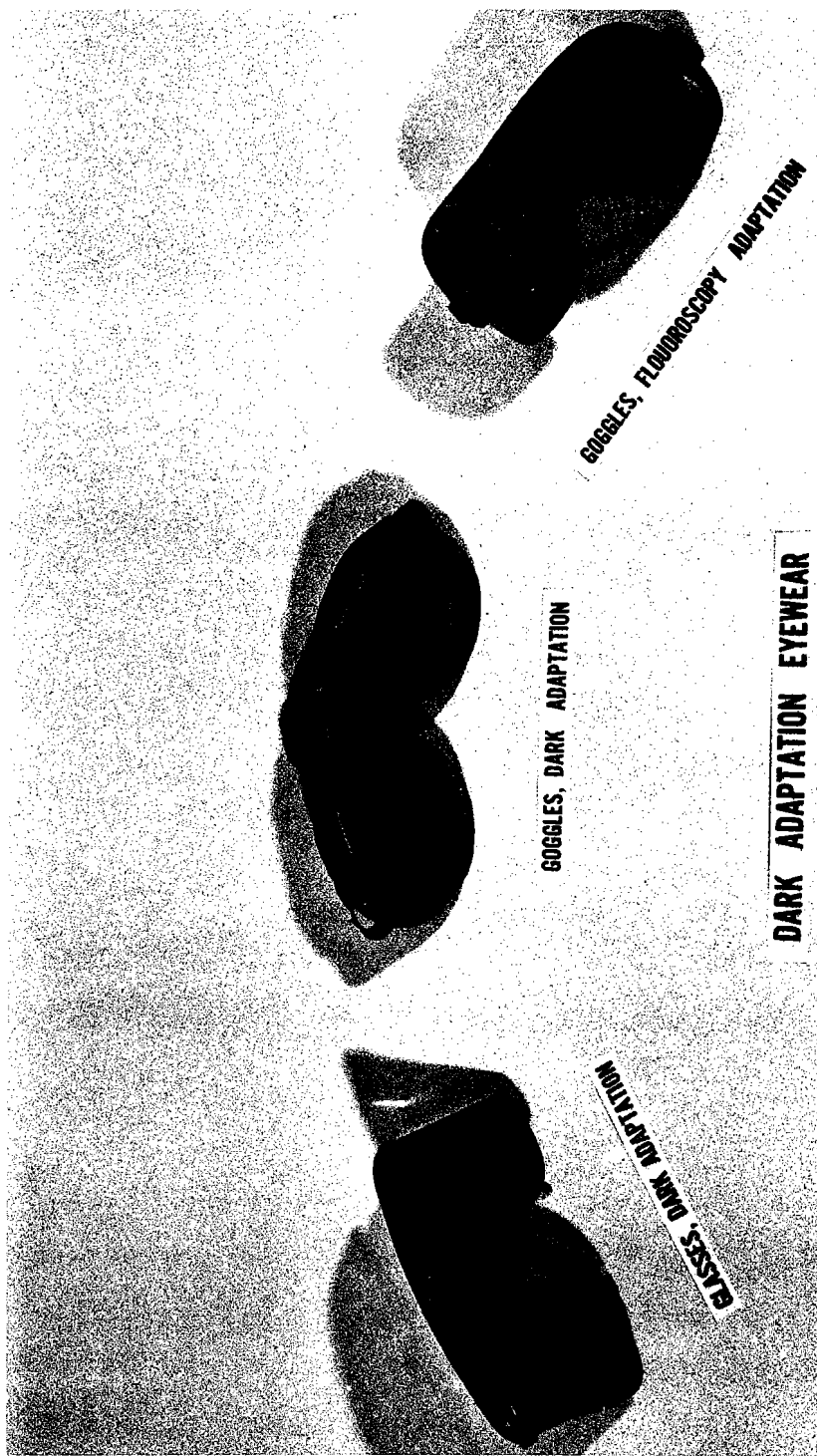

GOGGLES, DARK ADAPTATION

GOGGLES, FLUOROSCOPY ADAPTATION

DARK ADAPTATION EYEWEAR

GLASSES, DARK ADAPTATION

FIGURE 2

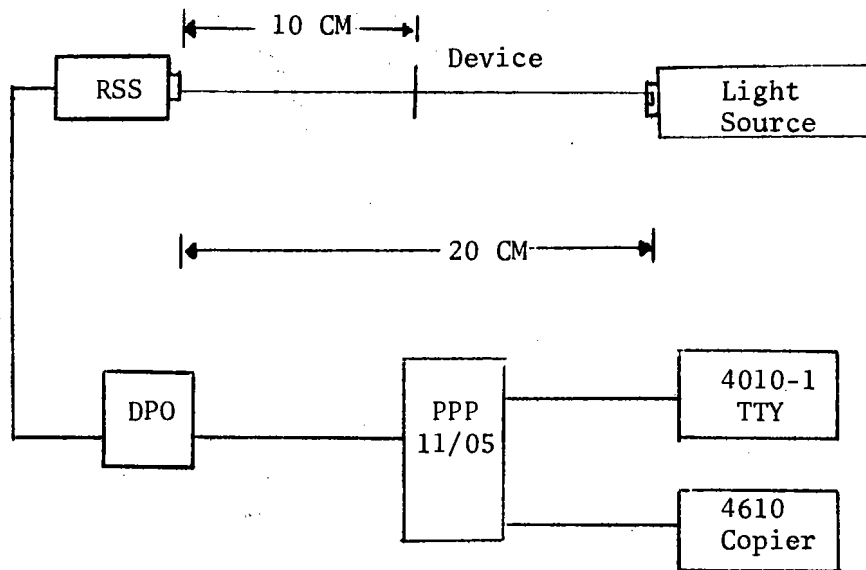

FIGURE 3. Experimental Arrangement

*GRA PA

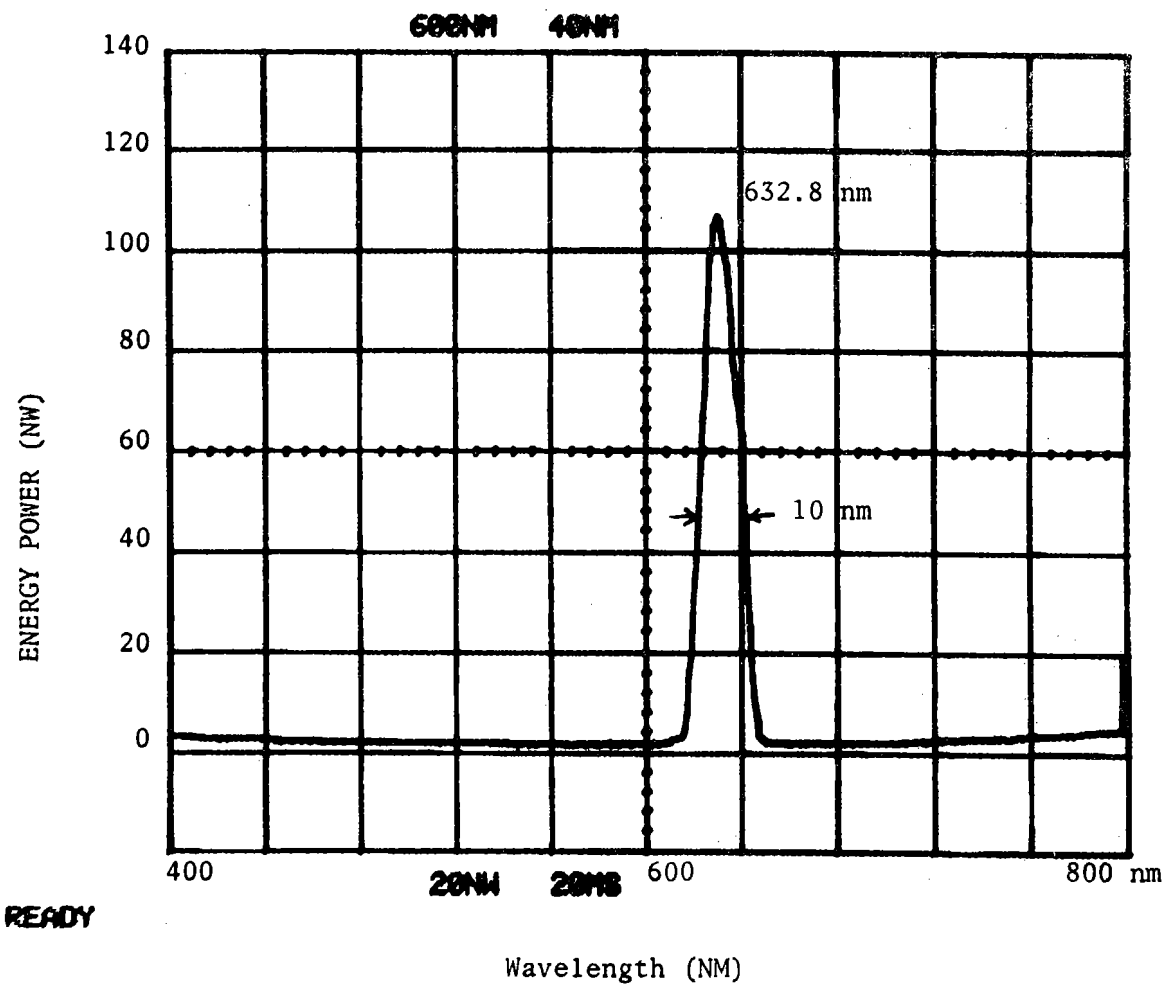

FIGURE 4. Spectral Power Distribution of HE-NE Laser

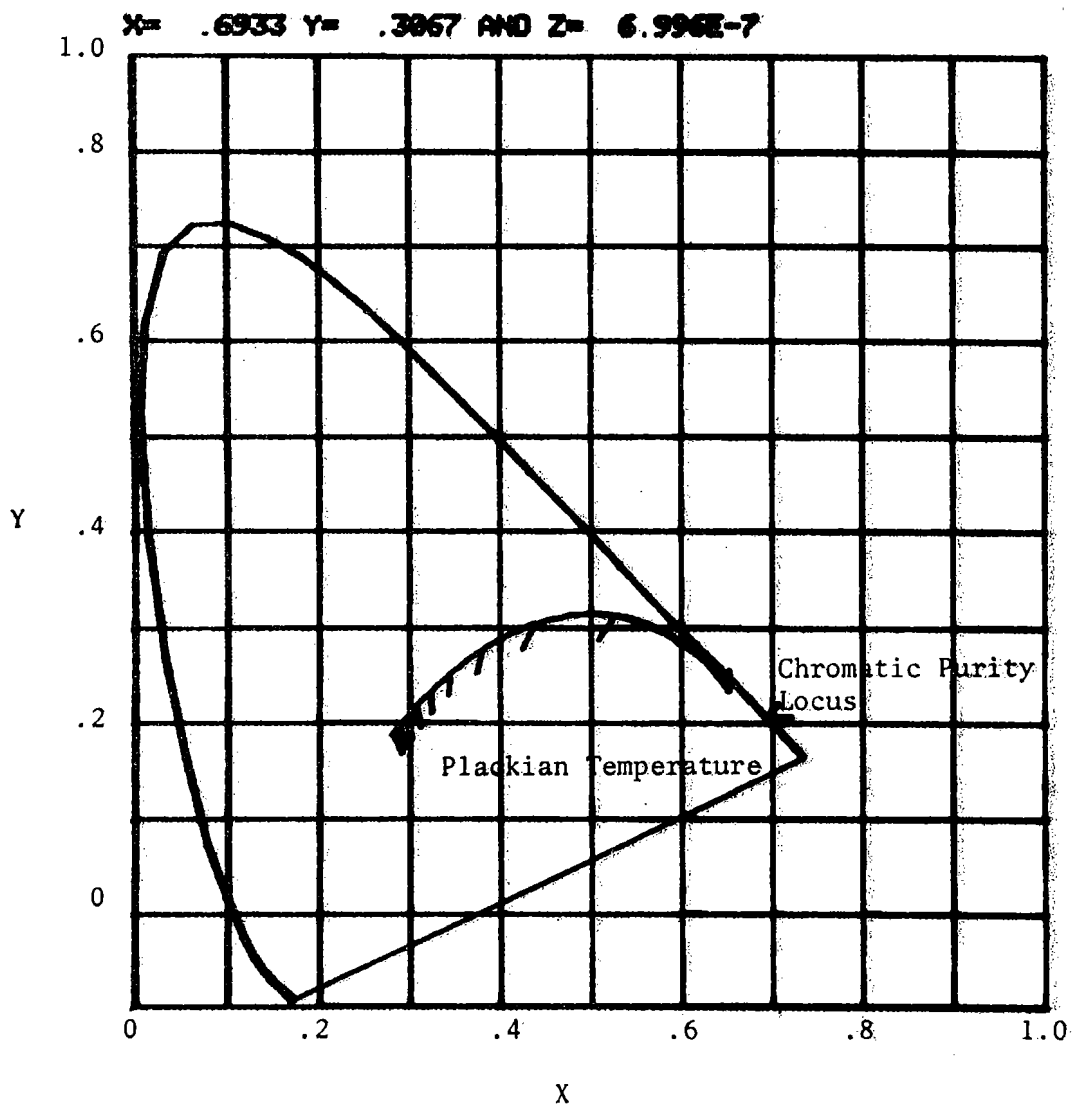

FIGURE 5. CIE Chromaticity Diagram of HE-NE Laser

GRA PA, PB, PC

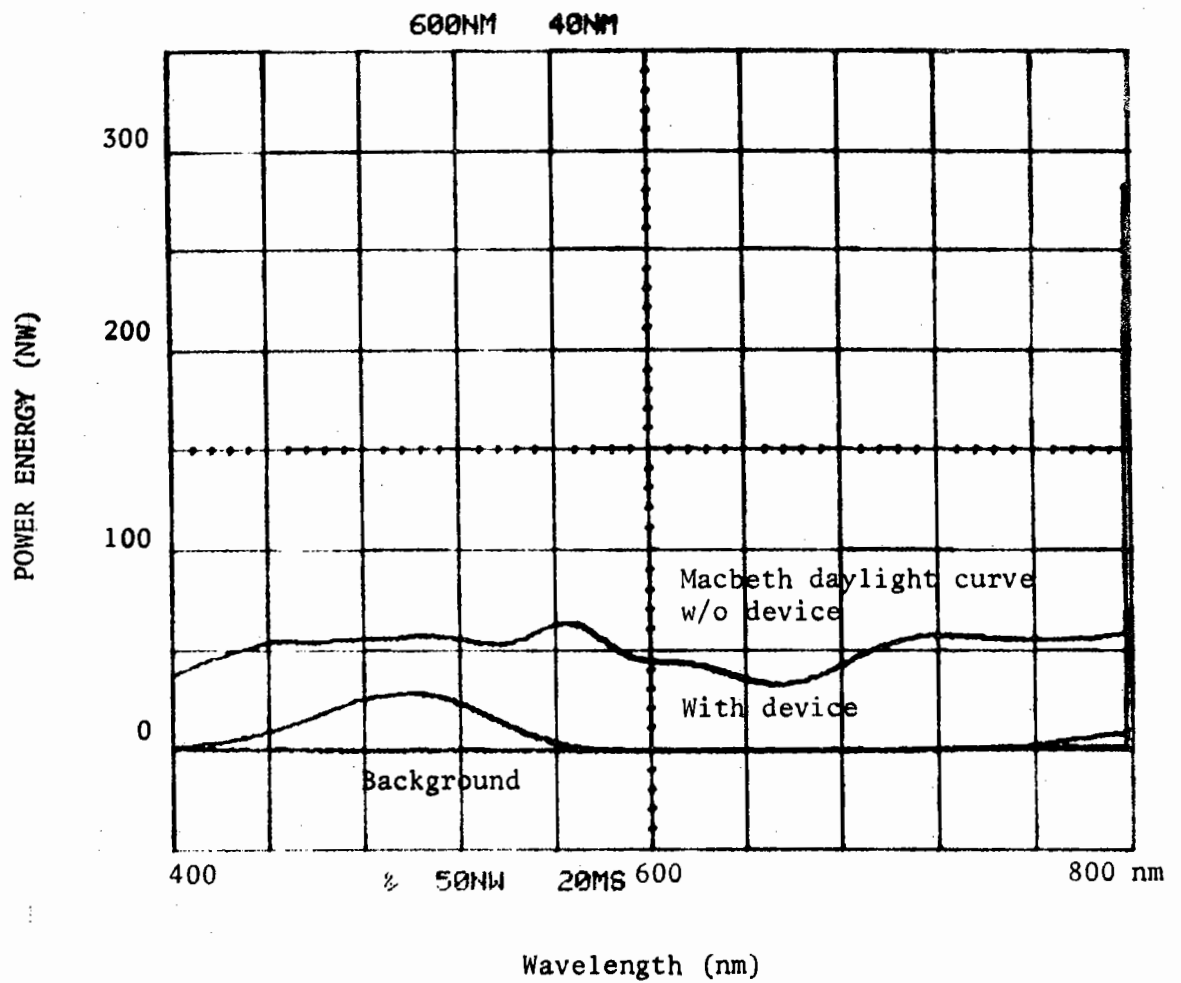

FIGURE 6. Power Spectral Distributions of Macbeth Daylight Lamp with and without Safety Device in the Optical Axis.

*LET PC=0:LET PC=PB/PA
READY
*GRA PC

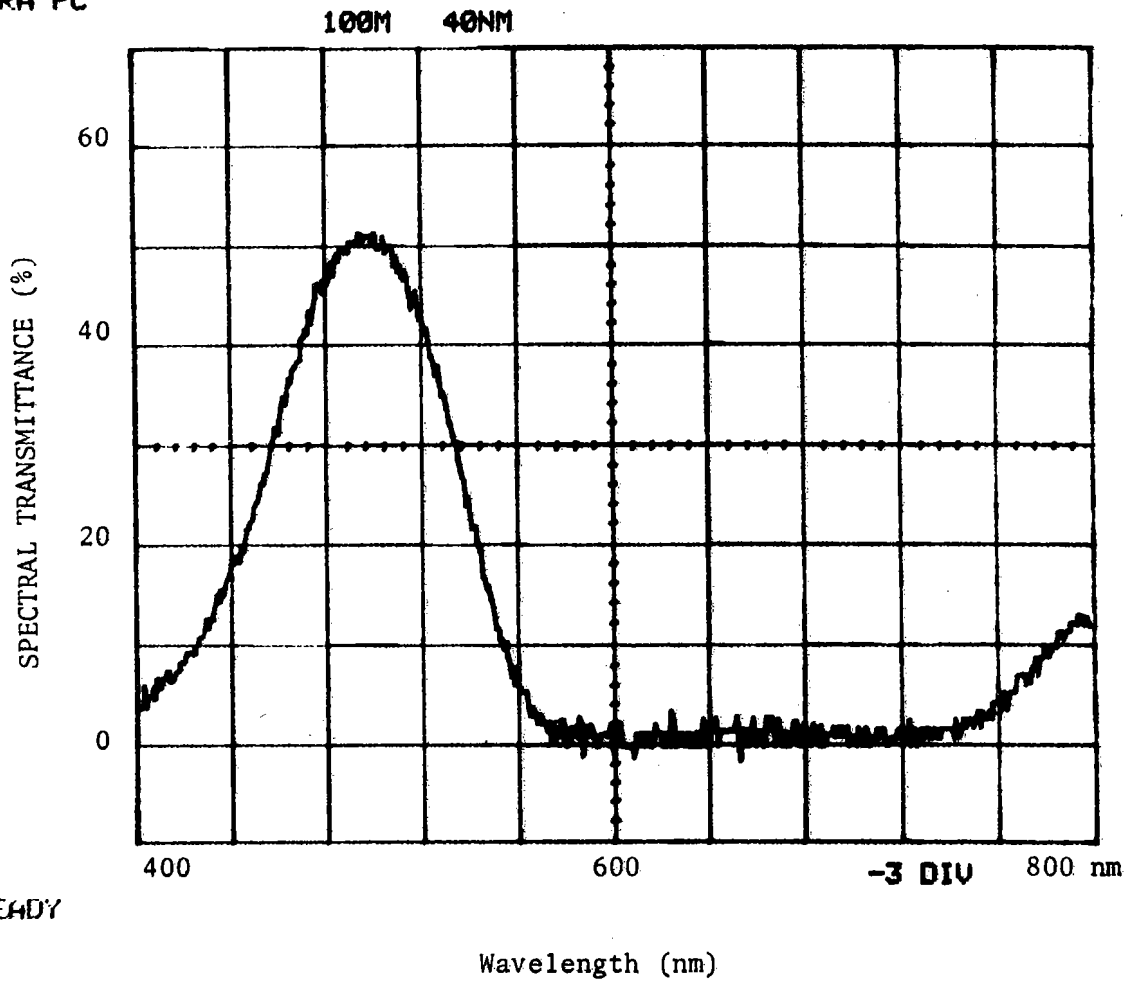

FIGURE 7. Unsmoothed Spectral Transmittance of Type I Goggles

*LET PA=PC
READY
*GRA PA

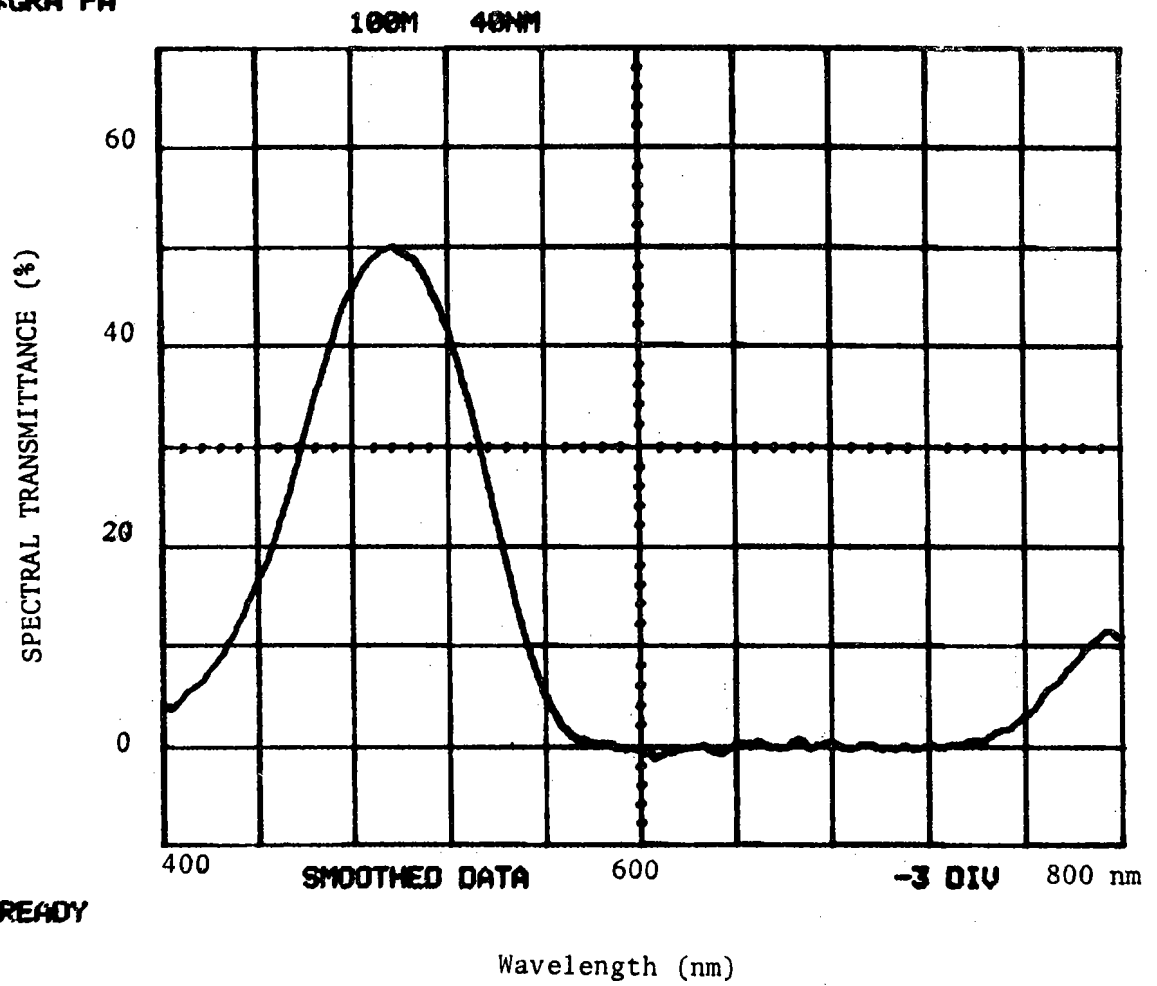

FIGURE 8. Smoothed Spectral Transmittance of Type I Goggles

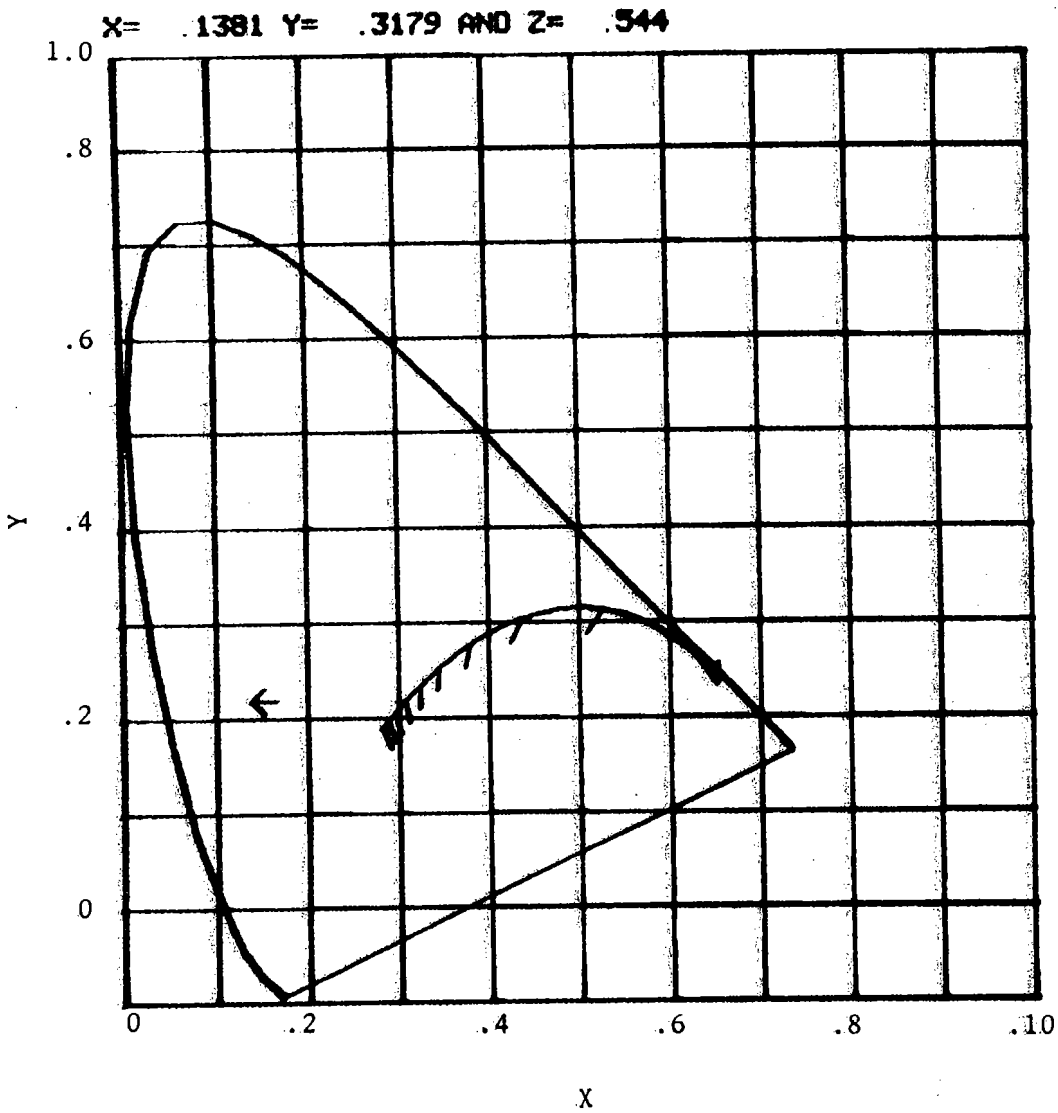

FIGURE 9. CIE Chromaticity Diagram of Type I Goggles with Macbeth Light Source

*REM SPECTRAL TRANS. CURVE FOR SCS-50 LASER SAFETY GOGGLES
*REM \SPECTRAL RANGE IS FROM 400 TO 800 NM
*GRA PAVC

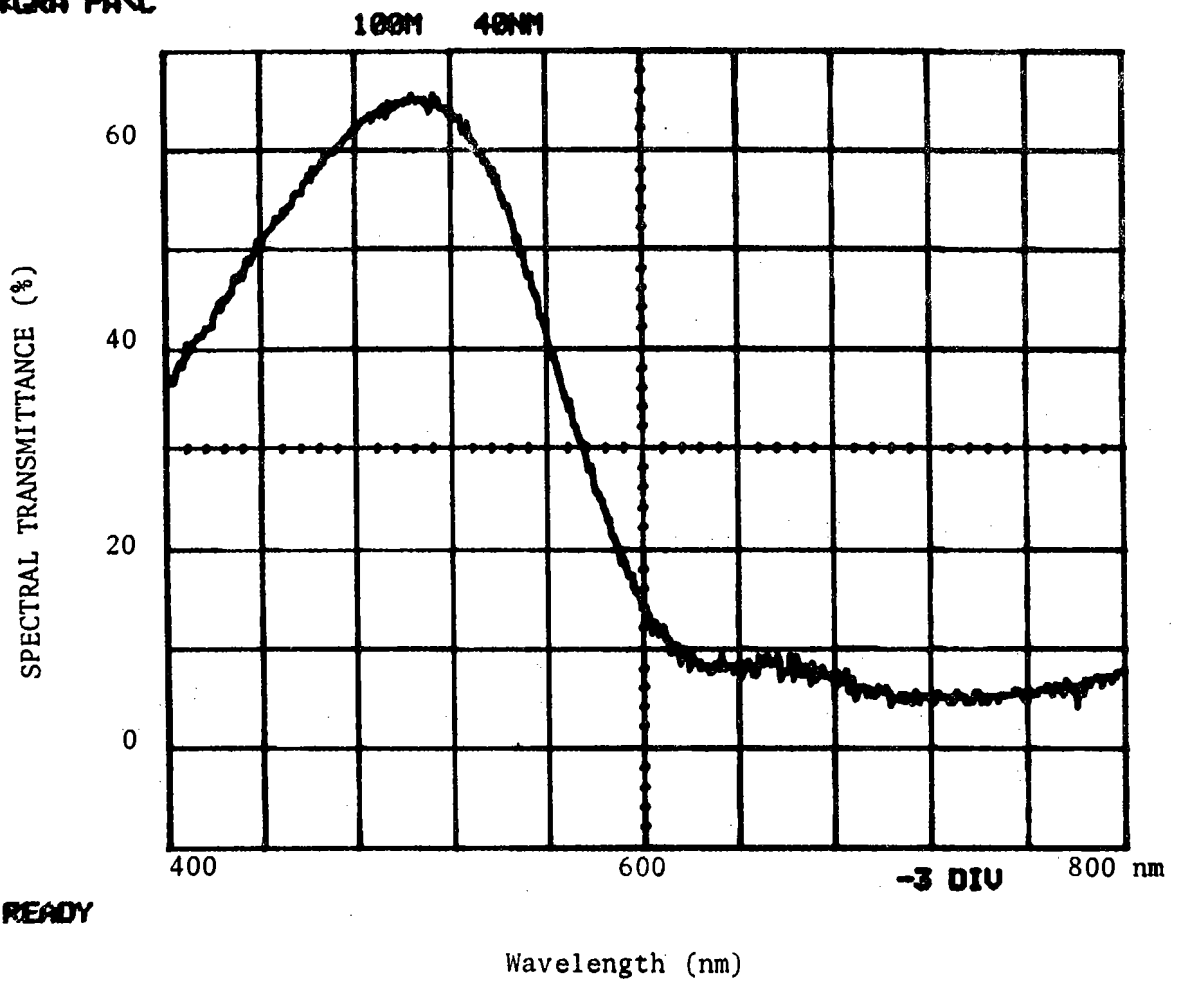

FIGURE 10. Unsmoothed Spectral Transmittance of Type II Device

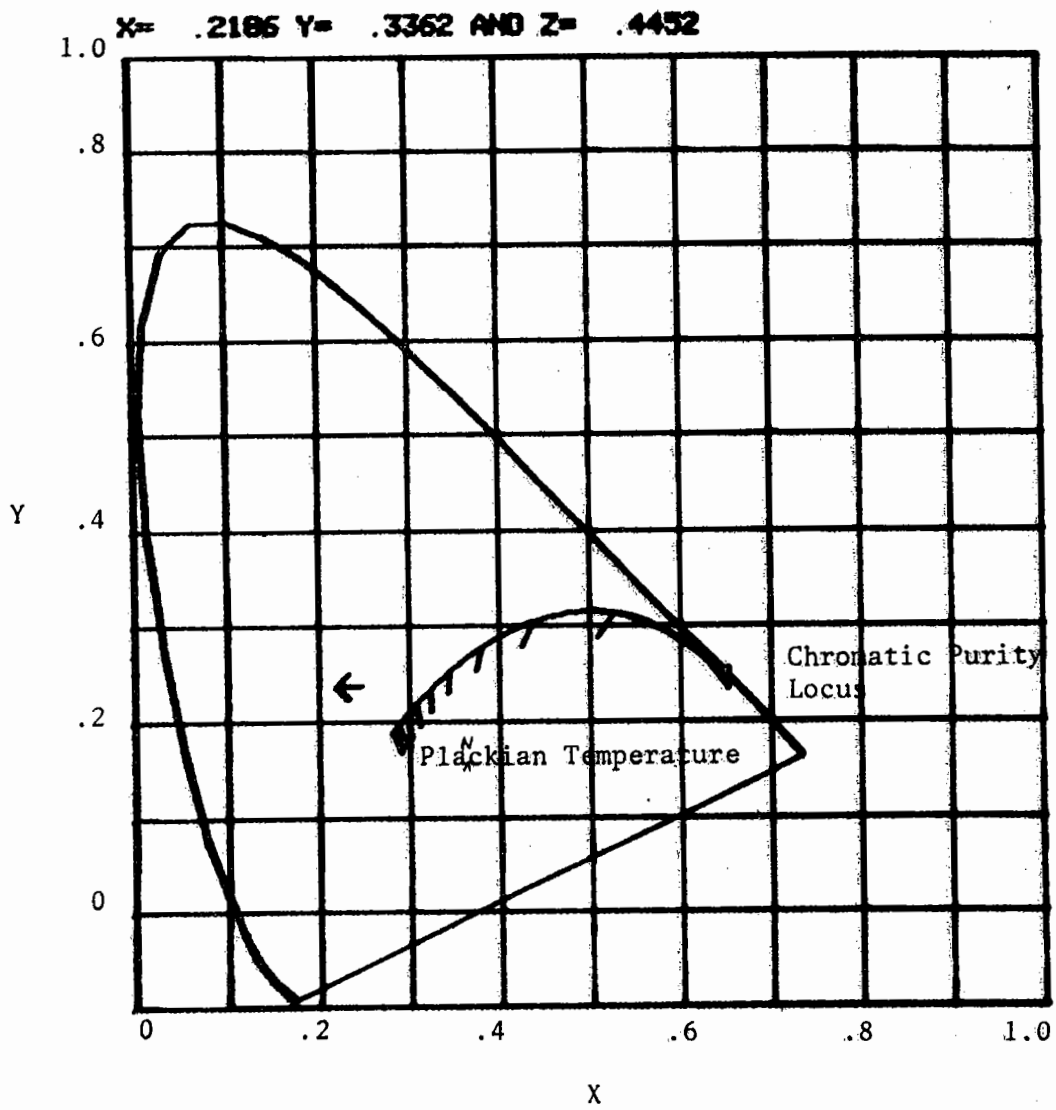

FIGURE 11. CIE Chromaticity Diagram of Type II Device with Macbeth Lamp

REM SPECTRAL TRANS. WWII DARK ADAPTATION GOGGLES
 #000 PA

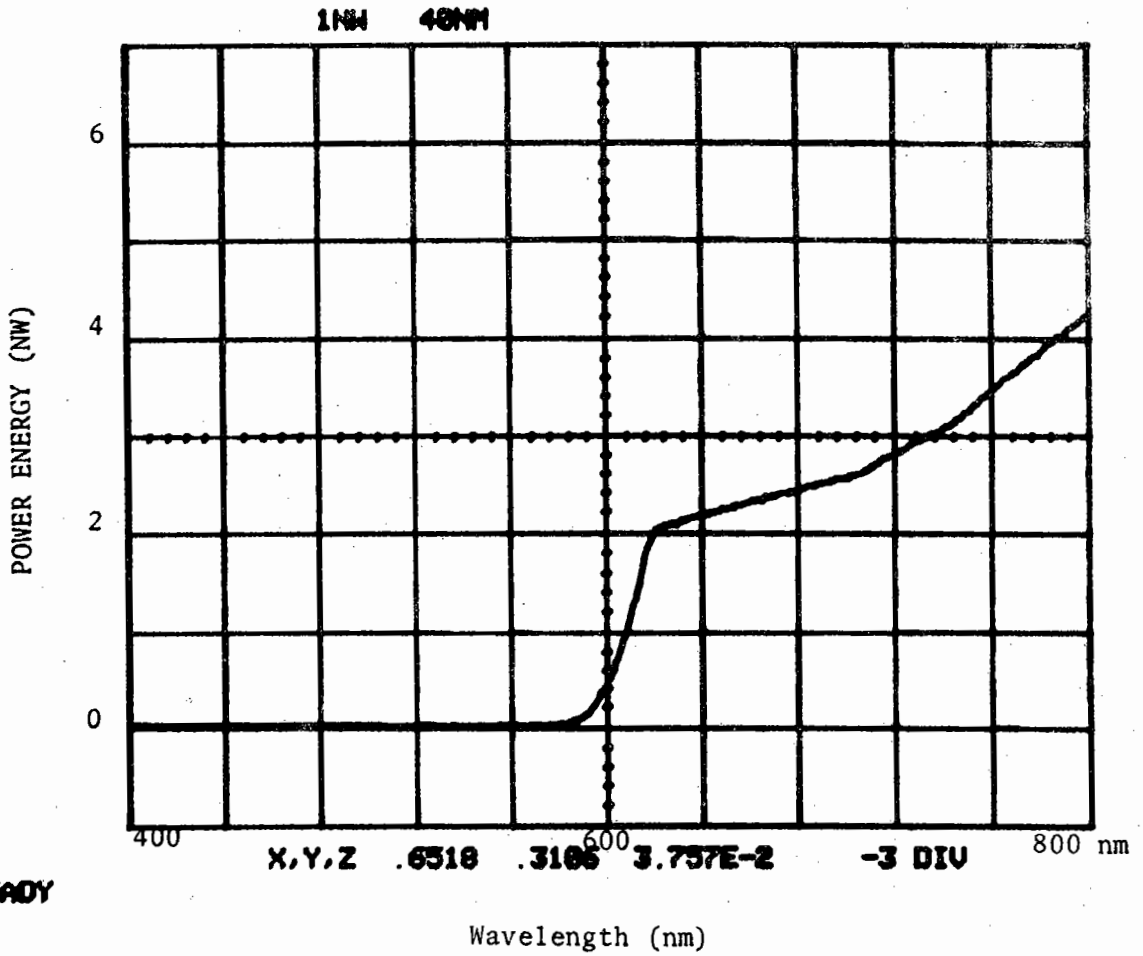
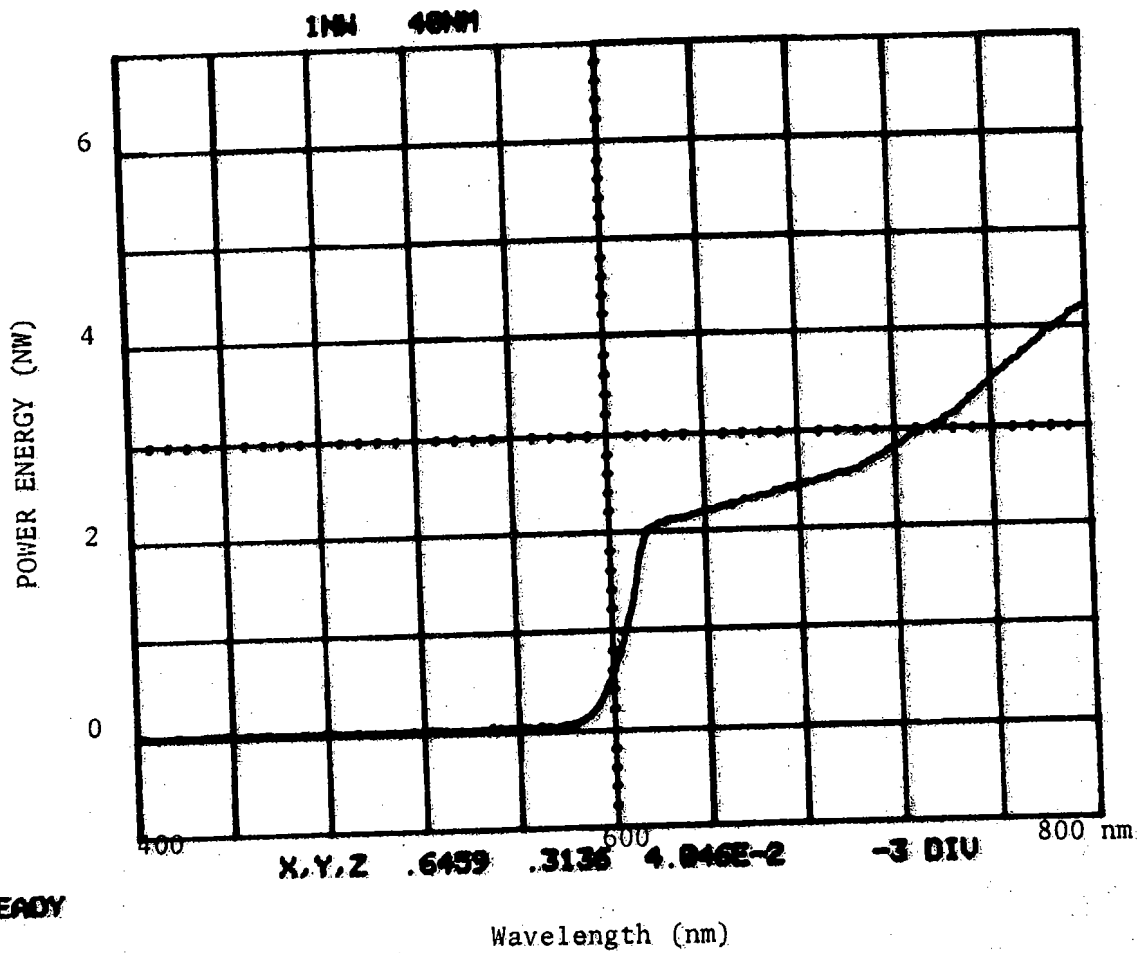

FIGURE 12. Spectral Transmittance for WW II Dark Adaptation Goggles

REM SPECTRAL TRANS. OF NAVY DARK ADAPTATION GOGGLES
 3GRA PA



READY

FIGURE 13. Spectral Transmittance for Navy Dark Adaptation Goggles

REM SPECTRAL TRANS. CURVE FOR X-RAY GOGGLE
 #GRA PA

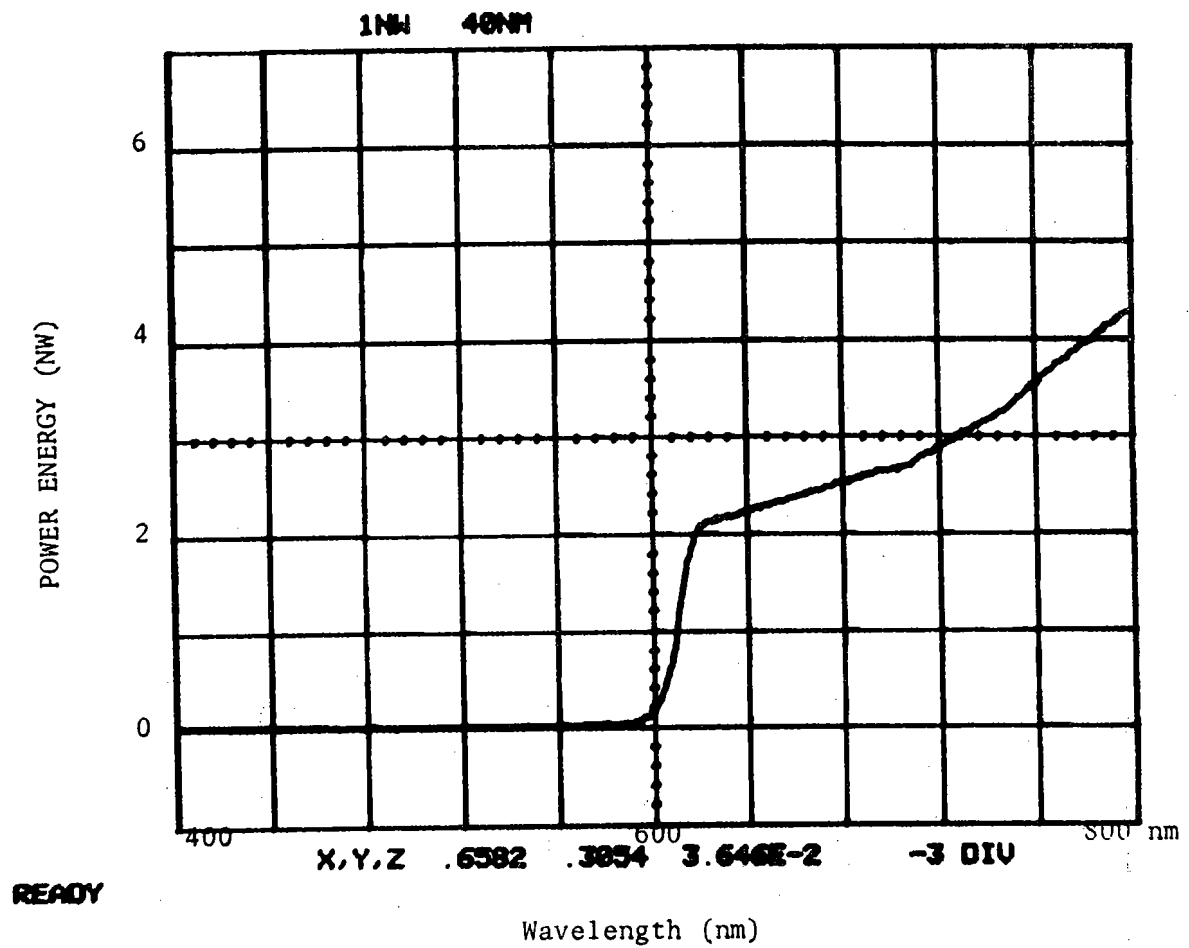

FIGURE 14. Spectral Transmittance for Fluoroscopy Dark Adaptation Goggles

REM SPECTRAL TRANS. CURVES FOR X-RAY, NAVY AND WWII DARK ADAPT. GOGGLE

3/ XGRA PA, PC, PD

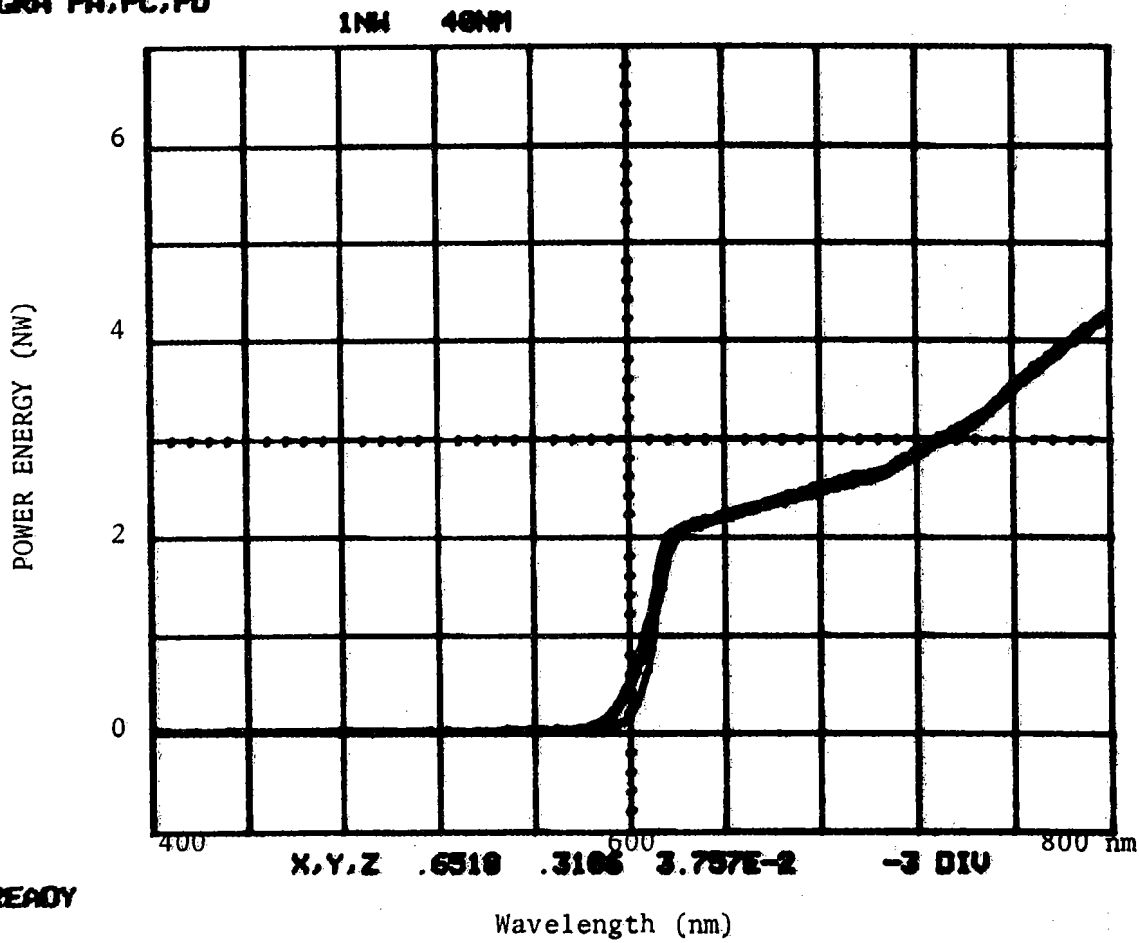

FIGURE 15. Comparison of S.T. for WW II, Navy & Fluoroscopy Dark Adaptation Goggles

REM SPECTRAL TRANS. CURVE (SMOOTHED) AFTER 5 MIN. EXPOSURE TO LASER
*GRA PA

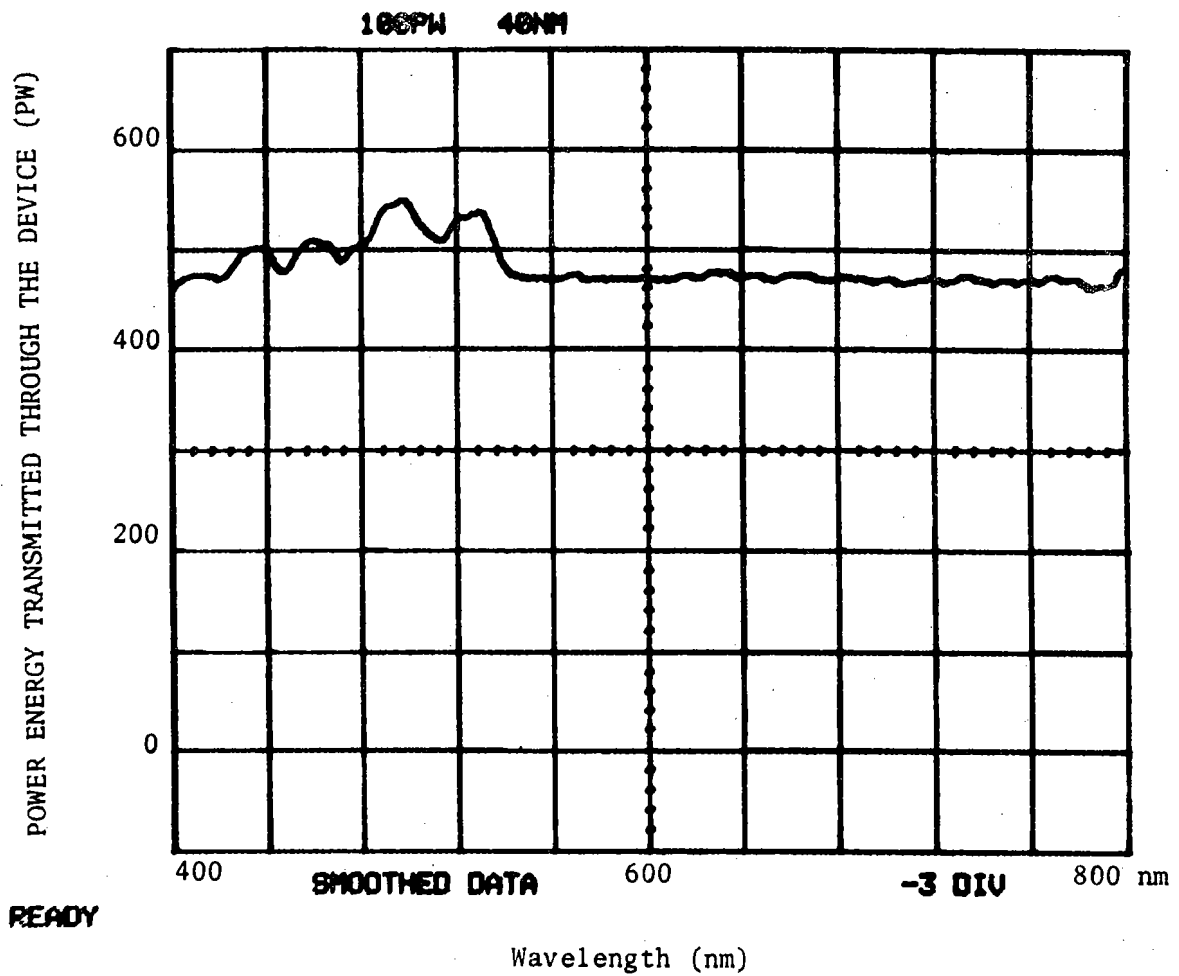

FIGURE 16. Power Energy Transmitted Through Device I
After 5 Minutes Exposure

REM SMOOTHED SPECTRAL TRANS. CURVE AFTER 10 MIN. EXPOSURE TO LASER
*GRA PA

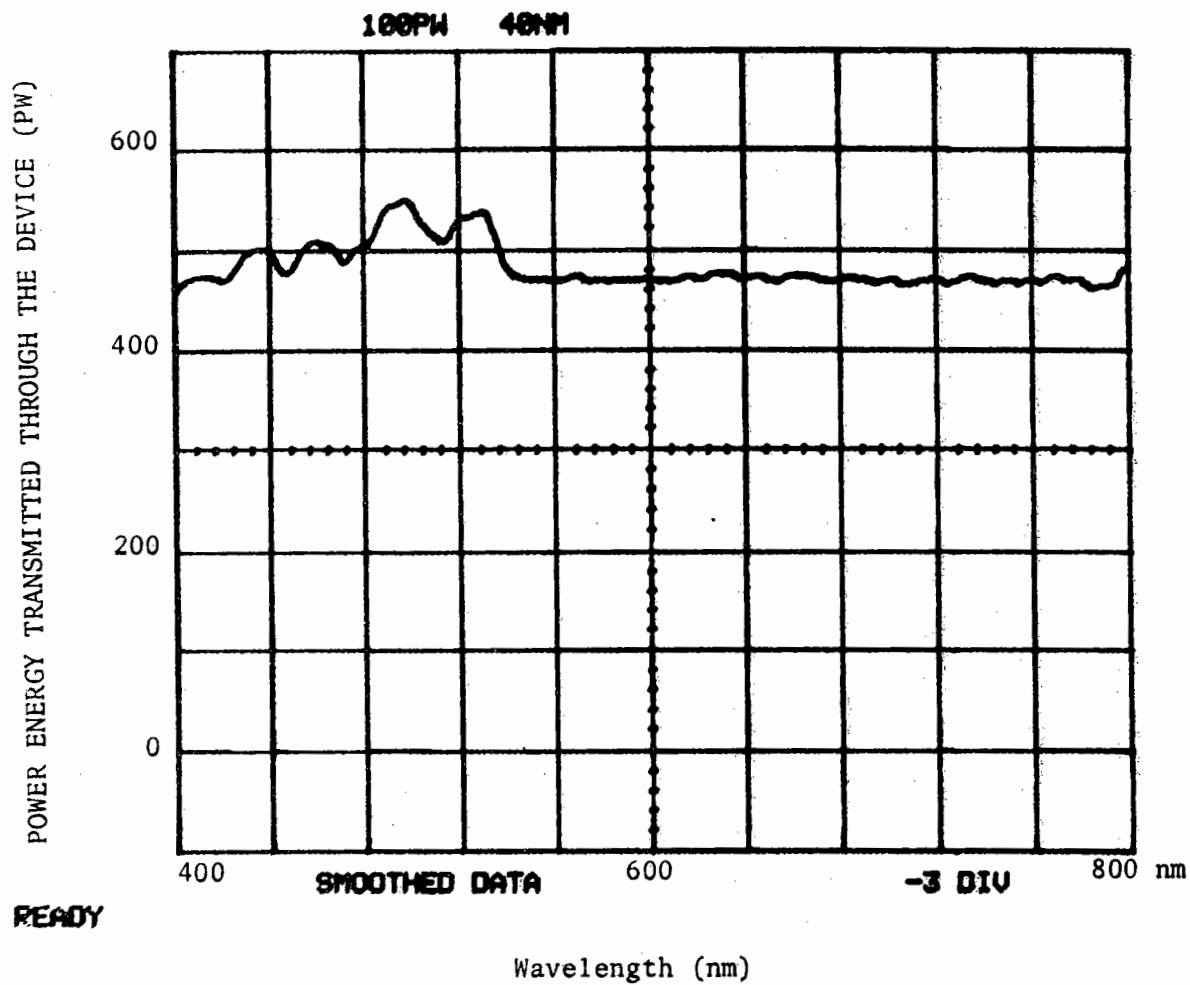

FIGURE 17. Power Energy Transmitted Through Device I
After 10 Minutes Exposure

*REM COMPARE 5 & 10 MIN EXPOSURE (SMOOTHED CURVES) 400-800 NM
*GRA PA,PD

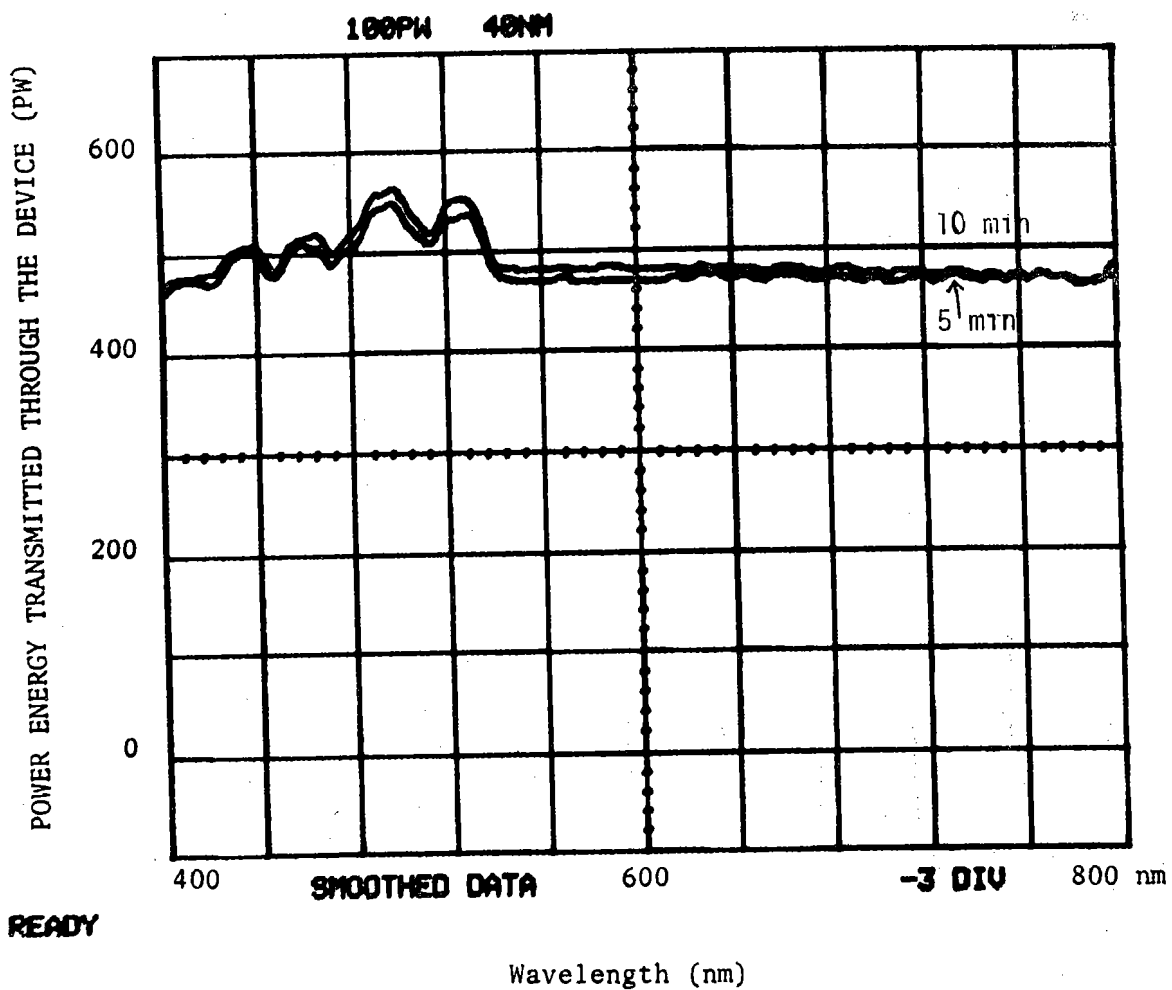

FIGURE 18. Compared Power Energy Transmitted Through Device I after 5 VS 10 Minutes Exposure

APPENDIX

COMPUTER PROGRAM FOR SMOOTHING THE "NOISY" CURVE (FROM STEP 300 TO 340)

```
*LIS
REMARK DPO TEK BASIC (CASSETTE) U01-01
100 REMARK ONE SHOT DATA
105 STR A
110 STR A,ME,2;FP
115 DISPLAY #44,"TRANSIENT CIRCUIT ARMED"
120 WAIT
125 HOLD A
130 LABEL PA,"TRANSIENT DATA"
145 STOP
200 REMARK AVERAGE DATA
205 HOLD A
210 HOLD A,ME;FP
215 AVERAGE PA/PB,32
220 HOLD B
225 LABEL PB,"DATA AVERAGED 32 TIMES"
230 STOP
300 REMARK SMOOTH DATA IN A
305 LET PB=PA
310 DIFFERENTIATE B,A
315 LET X=B(X)
320 INTEGRATE A,A
325 LET PA=A+X
330 LABEL PB,"ORIGINAL DATA"
335 LABEL PA,"SMOOTHED DATA"
340 STOP
400 REMARK FAST FOURIER TRANSFORM
405 HOLD A,ME;FP
410 HOLD A
415 DISPLAY #51,"F.F.T. IN PROCESS"
420 LET B=PA-NEAK PA)
425 FFT B,D,C,POLAR
430 LET HD=80/2
435 LET TD=256
440 LET PD=0
```