

AD-A020 146

RE-ORIENTATION SPECTROSCOPY OF STORED IONS

Hans G. Dehmelt

Washington University

Prepared for:

Office of Naval Research

September 1975

DISTRIBUTED BY:

NTIS

National Technical Information Service
U. S. DEPARTMENT OF COMMERCE

040082

10-25-7520

Scipini

(1)
B.S.

FINAL REPORT

for

DEPARTMENT OF THE NAVY
OFFICE OF NAVAL RESEARCH
(Physics Branch)
Arlington, Virginia 22217
CONTRACT N00014-67-A-0103-G009

ADA020146

Project Number: NR 014-307

TITLE:

RE-ORIENTATION SPECTROSCOPY OF STORED IONS

PERIOD:

May 1969 - May 1974

CONTRACTOR:

Board of Regents
University of Washington
Seattle, Washington 98195

UNCLASSIFIED

SUBMITTED BY:

RF-Spectroscopy Laboratory
Department of Physics
University of Washington
Seattle, Washington 98195

PREPARED BY:

Professor H.G. Dehmelt
Principal Investigator

Reproduced by
NATIONAL TECHNICAL
INFORMATION SERVICE
US Department of Commerce
Springfield, VA. 22151

Distribution of this document is unlimited.

September 1975

A123

NO COPY FOR PRODUCTION

**Best
Available
Copy**

The results of the work performed under the partial sponsorship of the contract are described in the 21 publications tabulated in the appended list. Surveys of this work are contained in two review articles prepared by the author, "A Progress Report on the G-2 Resonance Experiments", Proceedings, Fifth International Conference on Atomic Masses and Fundamental Constants, Paris 1975, Plenum Press 1976 and "The Ion Storage Collision Technique", Invited Papers, Ninth International Conference on the Physics of Electronic Atomic Collisions, Seattle 1975, University of Washington Press 1976. Preprints of these articles are attached.

It may deserve special special that during the work with stored electron clouds an important insight was gained. When energy and angular momentum are absorbed by the cyclotron motion and transferred via e-e collisions to the axial and magnetron motion but only energy is dissipated by the axial motion, the radial extension of the cloud must shrink. This follows from angular momentum conservation in the closed system electrons plus magnet. The principle may be of use in the containment of fusion plasmas.

It is a pleasure to note the group of younger men who have participated in the work of the contract; these include post-doctoral men brought in from other institutions, men who had been awarded the Ph.D. degree at the University of Washington and remained to follow promising lines of research and to capitalize on an investment in equipment and on their immediate facility with the body of ideas with which the work of the contract is concerned, and those having earned doctorates.

The list of publications records the support by the subject contract of work of the following postdoctoral men who had earned the Ph.D. degree at institutions other than the University of Washington:

DOCUMENT CONTROL DATA - R & D

(Security classification of title, body of abstract and indexing annotation must be entered when the overall report is classified)

1. ORIGINATING ACTIVITY (Corporate author)		2a. REPORT SECURITY CLASSIFICATION	
University of Washington Department of Physics, RF Spectroscopy Lab Seattle, Washington 98195		Unclassified	
2b. GROUP			
3. REPORT TITLE			
SPECTROSCOPY OF STORED IONS			
4. DESCRIPTIVE NOTES (Type of report and inclusive dates)			
Final Report			
5. AUTHOR(S) (First name, middle initial, last name)			
Hans G. Dehmelt			
6. REPORT DATE		7a. TOTAL NO. OF PAGES	7b. NO. OF REFS
September 1975		47	84
8a. CONTRACT OR GRANT NO.		9a. ORIGINATOR'S REPORT NUMBER(S)	
N00014-67-A-0103-0009			
b. PROJECT NO.			
NR 014-307			
c.		9b. OTHER REPORT NO(S) (Any other numbers that may be assigned this report)	
d.			
10. DISTRIBUTION STATEMENT			
Distribution of this document is unlimited			
11. SUPPLEMENTARY NOTES		12. SPONSORING MILITARY ACTIVITY	
		Department of the Navy Office of Naval Research Physics Branch	
13. ABSTRACT			
<p>The results of a program of research in the rf spectroscopy of stored ions are described. Work has been done on the study of magnetic resonance and hfs of e^-, and H_2^+. Techniques for measuring the temperature of ion gases and their radiative cooling have been developed. Continuous observation of a single electron oscillating with an energy of $\approx 10^{-7}$ eV inside a penning trap has been realized, "Monoelectron Oscillator". A new principle of forced radial shrinking of stored ion cloud by simultaneous cyclotron excitation and axial damping has been proposed which may be of use in the confinement of fusion plasmas.</p>			

14 KEY WORDS	LINK A		LINK B		LINK C	
	ROLE	WT	ROLE	WT	ROLE	WT
Atomic Physics Molecular Physics Ion-storage Collision Technique in rf Spectroscopy Magnetic Resonance Hyper Fine Structure Ions: H_2^+ , e^- "Bolometric" Technique Ion Gas Cyclotron-resonance Monoelectron Oscillator Confinement of Fusion Plasmas						

Talbert Stein, Ph.D. Brandeis, Now Associate Professor, Wayne State University

R. S. VanDyck, Jr. Ph.D. Berkeley, Currently Research Associate University of Washington

D. S. Wineland, Ph.D. Harvard, Now with N.B.S., Boulder, Colorado

The following have earned doctoral degrees at the University of Washington and have continued as postdoctoral associates:

Philip Ekstrom, Now with Battelle Northwest Laboratories, Richland Washington

Stephen Menasian, Now with Fusion Energy Institute, Princeton, New Jersey

Fred Walls, Now with N.B.S., Boulder, Colorado.

PUBLICATIONS

Determination of the Anomalous Magnetic Moment of the Free Electron From Measurements Made on an Electron Gas at 80° K Using a Bolometric Technique F.H. WALLS, Doctoral Thesis, University of Washington, 1970

Differential Linear Stark Shift in Rb^{85} and Cs^{133} . P.A. EKSTROM, Doctoral Thesis, University of Washington, 1971, also Bulletin A.P.S. 16, 849 (1971).

High Resolution Study of the $(1, 1/2, 1/2) - (1, 1/2, 3/2)$ hfs transition in H_2^+ . S.C. MENASIAN and H.G. DEHMELT, Doctoral Thesis, University of Washington, 1973, also Bulletin A.P.S. 18, 408 (1973)

Spin Polarization of Stored Electrons or Positrons by rf Pumping. H. DEHMELT and P. EKSTROM, Bulletin A.P.S. 18, 408 (1973)

Observations of the g-2 Resonance of a Stored Electron Gas. F.L. WALLS and T.S. STEIN, Phys. Rev. Letters 31, 975 (1973)

Proposed $g-2/\delta\omega_z$ Experiment on Single Stored Electron or Positron. H. DEHMELT and P. EKSTROM, Bulletin A.P.S. 18 727 (1973)

On the Bolometric g-2 Experiment. H. DEHMELT and D. WINELAND, Bulletin A.P.S. 18, 786 (1973)

Electrostatic Shifts of ω_c, ω_z and ω_{g-2} in A Cloud of Identical Particles. H. DEHMELT and D. WINELAND, Bulletin A.P.S., 18, 1571 (1973)

Monoelectron Oscillator. D. WINELAND, P. EKSTROM, and H. DEHMELT, Phys. Rev. Letters, 31, 1279 (1973)

The Ion-Storage COLLISION Technique. HANS DELHELT, University of Washington, Invited Paper, Annual Meeting of APS Chicago 1974 Bulletin A.P.S. (1974)

Proposed Precision Electron/Ion Mass Spectrometry. D. WINELAND, Bulletin A.P.S. 18 (1973)

Thermal Noise in the Monoelectron Oscillator, H. DEHMELT, P. EKSTROM, and D. WINELAND, Bull. A.P.S. 19, 572 (1974)

Landau Level Dependent v_z -Shifts in the Monoelectron Oscillator, H. DEHMELT, P. EKSTROM, D. WINELAND and R. VAN DYCK, Bull. A.P.S. 19 572 (1974)

Electrostatic Frequency Shifts and Broadening in a Penning Trap, D. WINELAND and H. DEHMELT, Bull. A.P.S. 19, 642 (1974)

rf-Heated ($kT = 50\text{eV}$) Electron Gas ($N = 10^{10}$) Contained in Penning Trap, H. DEHMELT, R. VAN DYCK, P. EKSTROM, and D. WINELAND, Bull. A.P.S. 19, 643 (1974)

Line Shifts and Widths of Axial, Cyclotron and G-2 Resonances in Tailored, Stored Electron (Ion) Cloud, D. WINELAND and H. DEHMELT, Fourth International Conference on Atomic Physics, Heidelberg, July 22, 1974, Abstract; also International Journal of Mass Spectroscopy and Ion Physics 16, 338 (1975)

The Ion Storage COLLISION Technique, H. DEHMELT, Bull. A.P.S. 19, 14 (1974)

The Externally Heated Discharge Pump/Gauge Employing rf Radiation, VAN DYCK, EKSTROM, WINELAND, and DEHMELT, (Draft of Patent Application)

Principles of the Stored Ion Calorimeter, WINELAND and DEHMELT J. Applied Physics, 46, 919 (1975)

A 23

IX ICPEAC



SEATTLE
24-30 JULY 1975

NINTH INTERNATIONAL
CONFERENCE
ON THE PHYSICS OF ELECTRONIC
AND ATOMIC COLLISIONS

University of Washington
Seattle, Washington U.S.A.
24-30 JULY 1975

THE ION-STORAGE COLLISION TECHNIQUE

Hans G. Dehmelt

University of Washington

Seattle, Washington 98195, U.S.A.

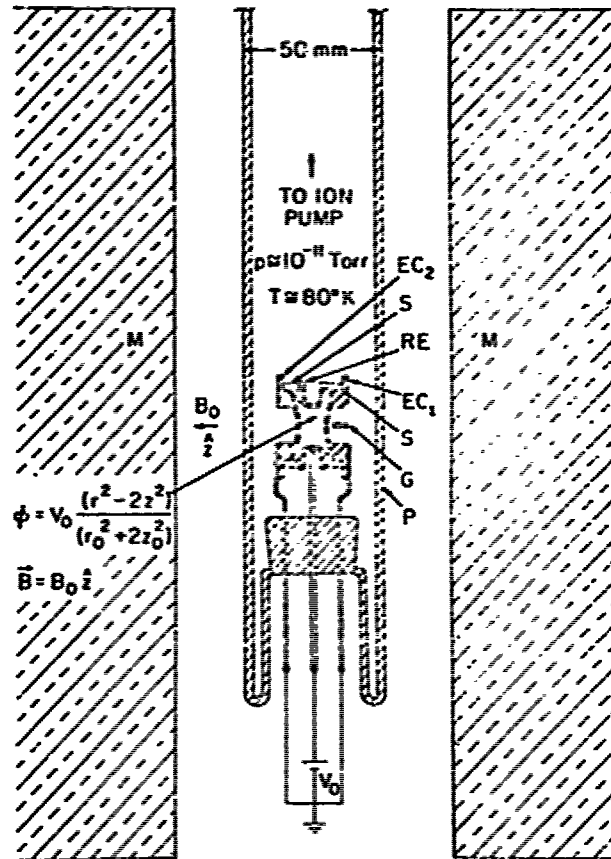

Fig. 1. Penning trap, EC = end caps, S = glass spacer, G = electron gun, P = Pyrex envelope, M = magnet. from (Wineland and Dehmelt, 1975b).

Orientation dependent collision processes such as $et + Na^+ \rightarrow . + Na^+$, (Dehmelt, 1958; 1961, & 1962; Graff et al., 1968, 1969 & 1972; Church & Mokri, 1971), $et + Na(2S) \rightarrow e + Na(2P) - \Delta E$, (Graff et al., 1968, 1969, Church & Mokri, 1971), see Fig. 5., $He^+ + Cs \rightarrow He^{2+} + Cs$, $He^+(1s^2S) + Cs \rightarrow He(2s^1S) + Cs^+ + \Delta E$ (Dehmelt & Major, 1962; Major & Dehmelt, 1968; Schuessler et al., 1969) see Fig. 2, and $h\nu(\leftrightarrow) + (H-H)^+ \rightarrow H + H^+ + \Delta E$, (Dehmelt & Jefferts, 1962; Richardson et al., 1967; Jefferts, 1968 & 1969), see Fig. 3 & 4, have been used in past spin- and hfs- resonance studies on stored ion. The special forte of the

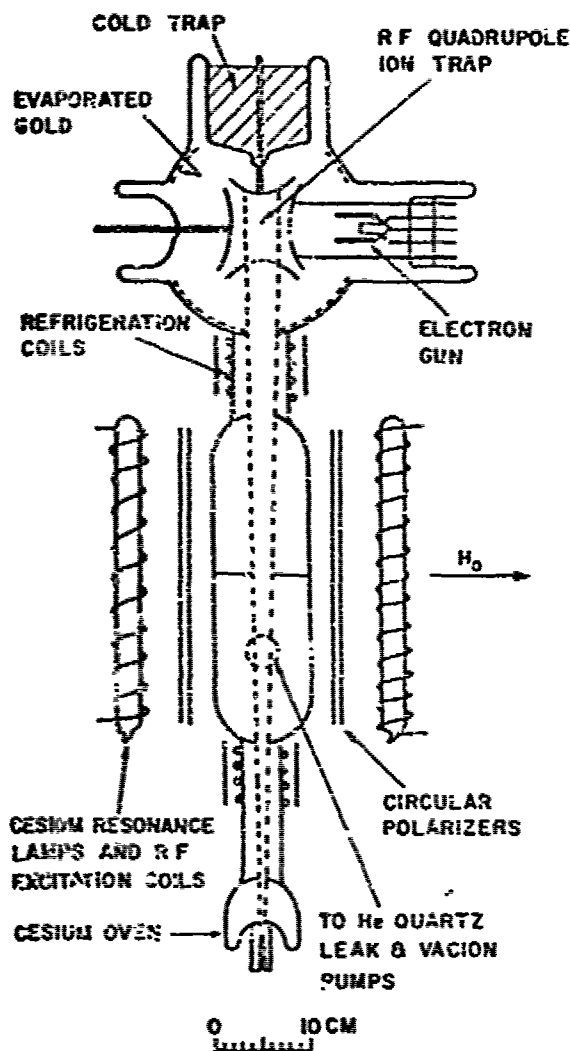

Fig. 2. Apparatus in which the first collision experiments with (polarized) stored ions (He^+) and a polarized atomic beam (Cs) were carried out, from (Dehmelt & Major, 1962).

technique here was orientation of the stored ions by collisions with an incoming beam of oriented projectiles. The early experiments of the author (1961) on electrons stored in a low-magnetic field Penning trap interacting with an optically polarized Na-Beam were undertaken with an apparatus resembling that shown in Fig. 2. Drastic reduction of the electron storage time in the presence of the Na-Beam or a variable pressure He gas background was observed, especially when a forced non-resonant oscillation of the electrons was excited. However, no spin dependent effects were seen at this time. As valuable by-products of all these studies some information on the relevant cross sections often was obtained also. Paul traps (rf quadrupole) (Fischer, 1959), were used for the atomic or molecular ions and Penning traps, cf. (Dehmelt, 1967), Fig. 1., for the electrons. The traps were filled by creating the ions, e.g. He^+ , e, inside them. In Paul traps the rf heating associated with ion-atom and ion-ion collisions accelerates evaporation, cf. (Dehmelt, 1967), of the ions out of the trap. A single ion in a perfect vacuum will presumably be stable. In the Penning trap ion-atom collisions also cause a biased random walk (Walls, 1970) of the cyclotron motion guiding centers towards the ring. The ions were "counted" primarily by interaction with an LC circuit tuned to their axial oscillation frequency and excited externally or merely thermally, Figs. 6, 7 & 8. This interac-

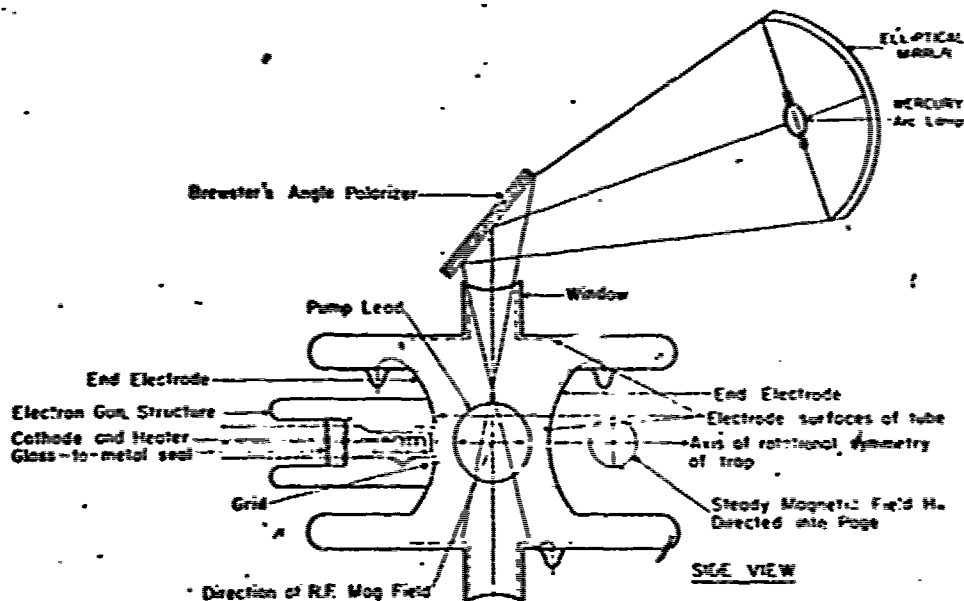
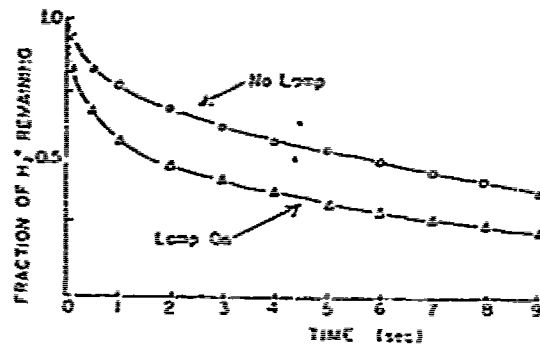
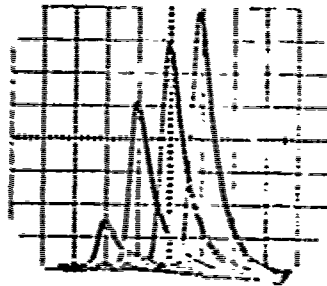

Fig. 3. Apparatus in which photodissociation experiments on stored (aligned) H_2^+ ions bombarded by polarized photons were carried out, from (Jefferts & Dehmelt, 1962).



Relative number of H₂⁺ ions trapped at *t* seconds after end of ionization pulse, for loop on and off.



Oscilloscope presentation of the detection of ions by the resonance method. Peaks represent number of H⁺ ions in the trap. The production is by photoionization of the simultaneously trapped H₂⁺. The four peaks are for H⁺ collection times of 50, 250, 450, and 650 msec. The largest represents 10% damping. Time base is 1 msec/division.

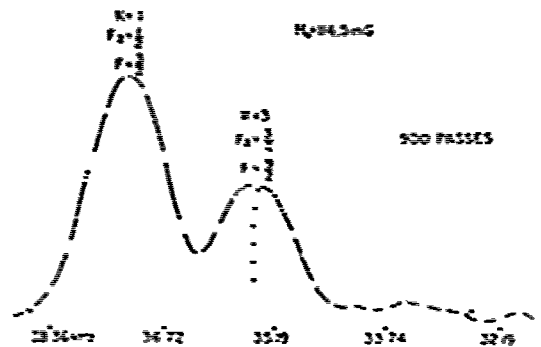

Magnetic resonance in H₂⁺ in a magnetic field H₂ = 111.5 mG. Peaks correspond to transitions among the Zeeman sublevels of the states shown. Interaction time was 3.5 h. The center of points under the low-frequency peak represents the centroid of a third peak, not shown, which has been reported after additional passes have been scaled 5.9, the theoretical value of the ratio of magnetic moments of the states K=3, F=3/2, and K=1, F=1/2.

Fig. 4. Some experimental results obtained with an apparatus similar to that of Fig. 7, from (Richardson et al., 1963).

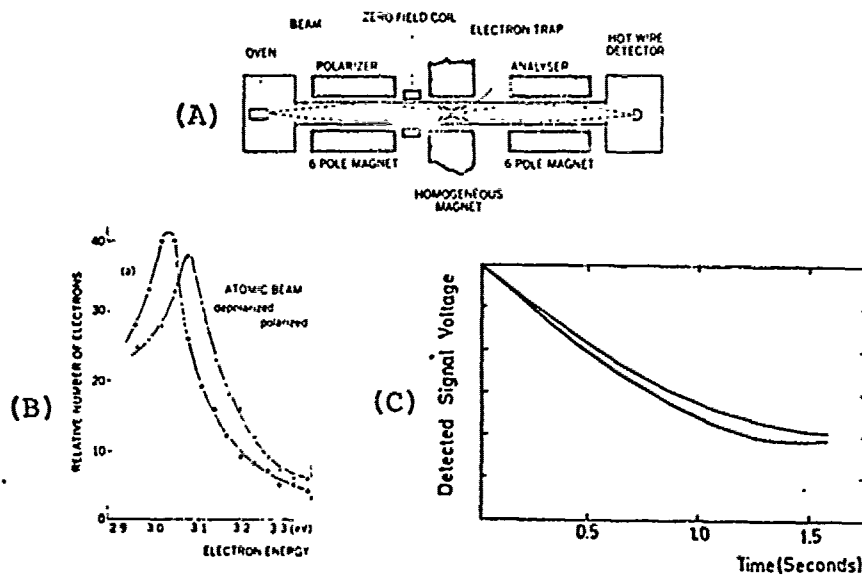
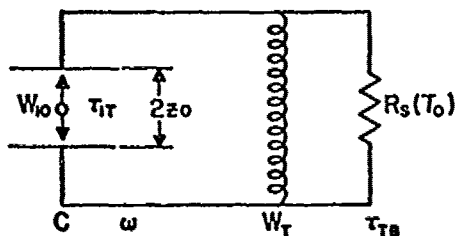

Fig. 5. Stored electron cloud/Na-Beam experiment. (A) Shows apparatus in which collisions between electrons stored in a Penning trap and a beam of polarized Na-Atoms were studied. (B) Shows spin-dependent change of energy distribution in stored electron cloud due excitation of Na D-lines. (C) Shows analogous temperature observed by noise thermometry. (A,B) from (Graff et al., 1968), (C) from (Church & Mokri, 1971).

SINGLE HOT ION INTERACTING WITH TUNED CIRCUIT



NUMERICAL EXAMPLE

$M = 100 M_H$; $2z_0 = 0.5 \text{ cm}$
 $C \approx 10^{-11} \text{ F}$; $Q = 100$
 $\omega \approx 5 \times 10^5 \text{ CPS}$; $R_3 \approx 2 \times 10^7 \Omega$
 $\tau_0 \approx 13 \text{ sec}$; $W_{10} \approx 3 \text{ eV}$
 $S/N \approx 100$, $kT_0 \approx 0.03 \text{ eV}$

THERMALIZATION OF ION

$$W_T = kT_0 \div (W_{10} - kT_0) \exp(-t/\tau_{IT})$$

$$\tau_{IT} = (4M z_0^2) / (e^2 R_s)$$

OPTIMUM SIGNAL TO NOISE RATIO

INITIAL ENERGY OF ION, W_{10} , FLOWS SLOWLY INTO TANK, FAST INTO BATH, $\tau_{IT} \gg \tau_{TB}$. RETAINED IN TANK FOR INTERVAL $\approx \tau_{TB}$, $W_T \approx (\tau_{TB}/\tau_{IT}) W_{10}$. THERMAL FLUCTUATIONS OF TANK ENERGY FOR OBSERVATION TIME $\approx \tau_{IT}$ AVERAGE OUT TO $\Delta W_T \approx (\tau_{TB}/\tau_{IT}) kT_0$, $S/N = W_T / \Delta W_T$;

$$S/N \approx W_{10} / kT_0$$

Fig. 6. Brief analysis of hot oscillating ion interacting with resonant tuned circuit, from (Dehmelt, 1962).

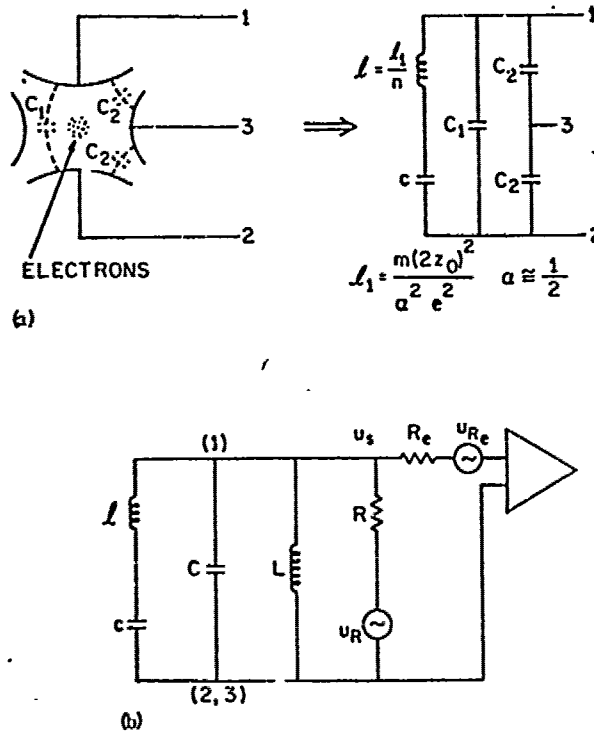

Fig. 7. Electrical equivalent representations of electrons in the Penning trap structure. (a) Pictorial representation of electrons in the Penning trap and electrical equivalent representation. (b) Electrical equivalent representation of electrons (l, c), Penning trap, and external circuit (L, C) showing noise voltages associated with real resistance R and fictitious transistor input noise resistor \$R_e\$, from (Wineland & Dehmelt, 1975b)

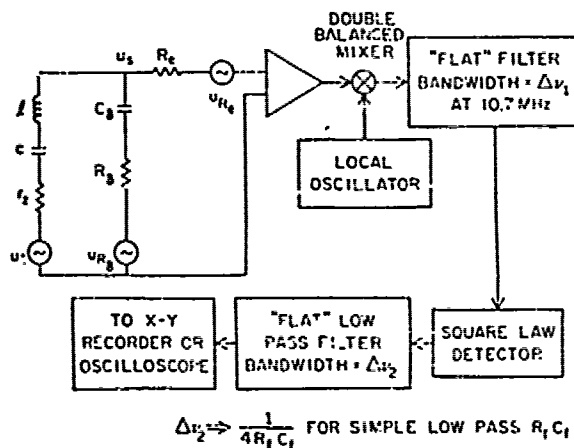

Fig. 8. Narrow frequency band model for electrons/ions (l, c, \$r_z\$) interacting with LC circuit (\$C_0\$, \$R_0\$) showing block diagram of detection electronics, from (Wineland & Dehmelt, 1975b).

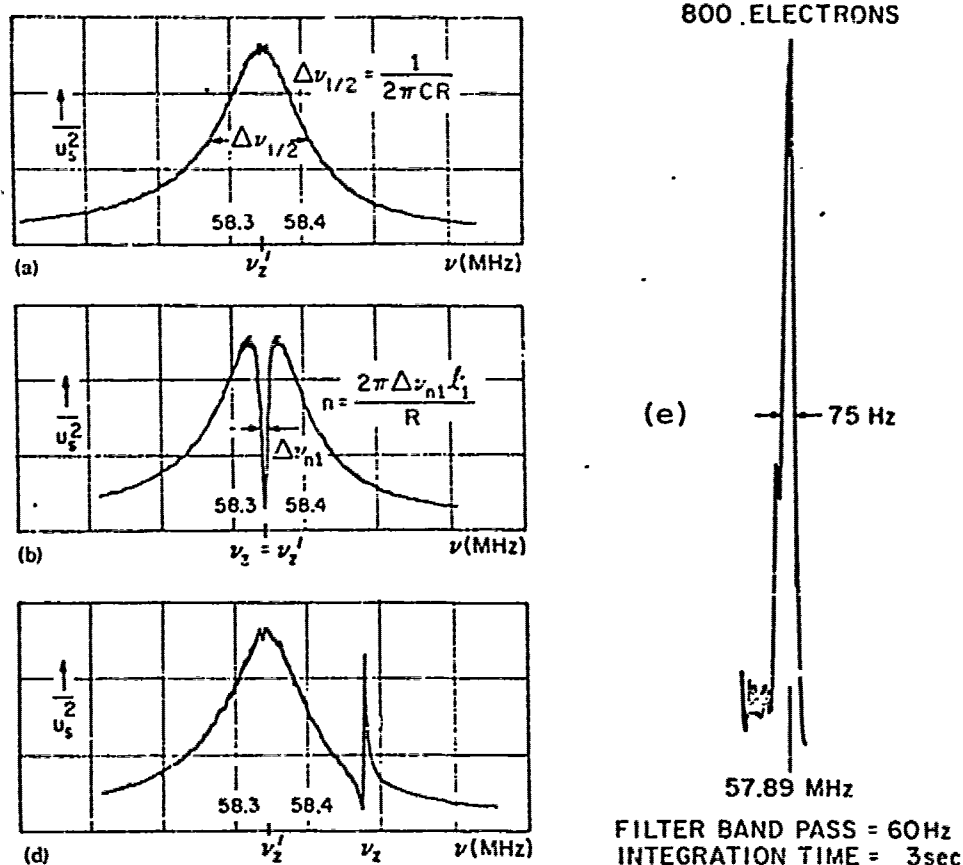

Fig. 9. Noise spectra associated with electrons and Penning trap external LC circuit. (a) Spectrum with electrons absent from trap. (b) Spectrum of $n \approx 5000$ electrons when electron axial resonant frequency $\nu_z = \nu_z'$, the LC circuit frequency. (c) Same for $\nu_z = \nu_z' + \sim 130$ kHz. Observation filter width $\Delta\nu_1 \approx 2$ kHz. From (Wineland & Dehmelt, 1975b). (d) Electron parallel resonance ($\nu_z > \nu_z'$) signal obtained with anharmonicity-compensated trap; Fig. 10., (Van Dyck et al., 1975).

tion is also being used to cool the ions. Cloud temperatures of $\sim 80^\circ\text{K}$ for e's in a Penning trap (Dehmelt & Walls, 1968), and $\sim 800^\circ\text{K}$ for protons in a Paul trap (Church & Dehmelt, 1969), have been found by measurements on the LC circuit, whose noise spectrum is grossly modified by the ions, Fig. 9. All the processes involving collisions listed above may be used to infer cross sections. Further, the forced center of mass oscillation of an ion cloud is not broadened by like ion interactions, (Wineland & Dehmelt, 1975a). The equations of motion of a single particle in a Penning trap under forced cyclotron/axial excitation $f_x(t)/f_z(t)$ may be written

$$\begin{aligned} m\ddot{x} - m\omega_z^2 x/2 + m\omega_c \dot{y} &= f_x(t), & (-m\omega_z^2/2 &= e\phi_{xx}) \\ m\ddot{y} - m\omega_z^2 y/2 - m\omega_c \dot{x} &= 0, & (-m\omega_z^2/2 &= e\phi_{yy}) \\ m\ddot{z} + m\omega_z^2 z &= f_z(t), & (m\omega_z^2 &= e\phi_{zz}) \end{aligned}$$

Electrostatic interactions between like particles in a cloud very small compared to the wavelength of the exciting r.f. field do not shift or broaden the cyclotron resonance at $\omega_c - \omega_m$ or the axial resonance at ω_z ,

$$\omega_c = eH_0/mc, \quad \omega_c \omega_m - \omega_m^2 = \omega_z^2/2 = -e\phi_{xx}/m$$

Rather, from the equations of the z-motion of two interacting particles

$$\begin{aligned} m\ddot{z}_1 + m\omega_z^2 z_1 &= F_{z12} + f_z(t) \\ m\ddot{z}_2 + m\omega_z^2 z_2 &= F_{z21} + f_z(t) \end{aligned}$$

it follows by addition that the center of mass coordinate $Z = (z_1 + z_2)/2$ obeys the same equation as a single particle,

$$m\ddot{Z} + m\omega_z^2 Z = f_z(t)$$

The same argument may be extended to the x and y coordinates and to an arbitrary number of identical particles.[†]) Experimentally for e-clouds in a Penning trap with compensated anharmonicity, Fig. 10, widths of 20 Hz have been realized, Fig. 9(e), (Van Dyck et al., 1975), making broadening due to e-atomic beam collisions detectable. Earlier a bolometric technique was proposed for the detection of energy transfer from other degrees of freedom to the axial motion, and such transfer from the microwave excited cyclotron motion via e-e or e-atom collisions was demonstrated (Dehmelt & Walls, 1968; Wineland & Dehmelt, 1975b). Estimates indicate that the sensitivity of the electron calorimeter realized should be sufficient to study such exothermic reactions as $e + H(F=1) \rightarrow e(\Delta m_s = \pm 1) + H(F=0) + 5 \mu\text{eV}$, in a stored electron cloud/H-beam apparatus. Most recently D. Wineland et al. have observed cyclotron resonance in the mono-electron oscillator in a similar fashion after the collision sensitive forced axial oscillation at $\sim 60\text{MHz}$ of a single e had been observed continuously, Fig. 11, (Wineland et al., 1973). The detection of the cyclotron resonance in the slightly anharmonic mono-electron oscillator was based on a trigger technique relying on off-resonance parametric excitation near $2\nu_z$. Energy transfer from the excited cyclotron motion to the axial motion via an electron/background-gas-atom collision moved the axial frequency ν_z within the regeneration range building up a large detectable forced oscillation, Fig. 12. Here operation with sharp cyclotron energies in the range .001-1 eV and axial energies <1meV seems feasible eventually

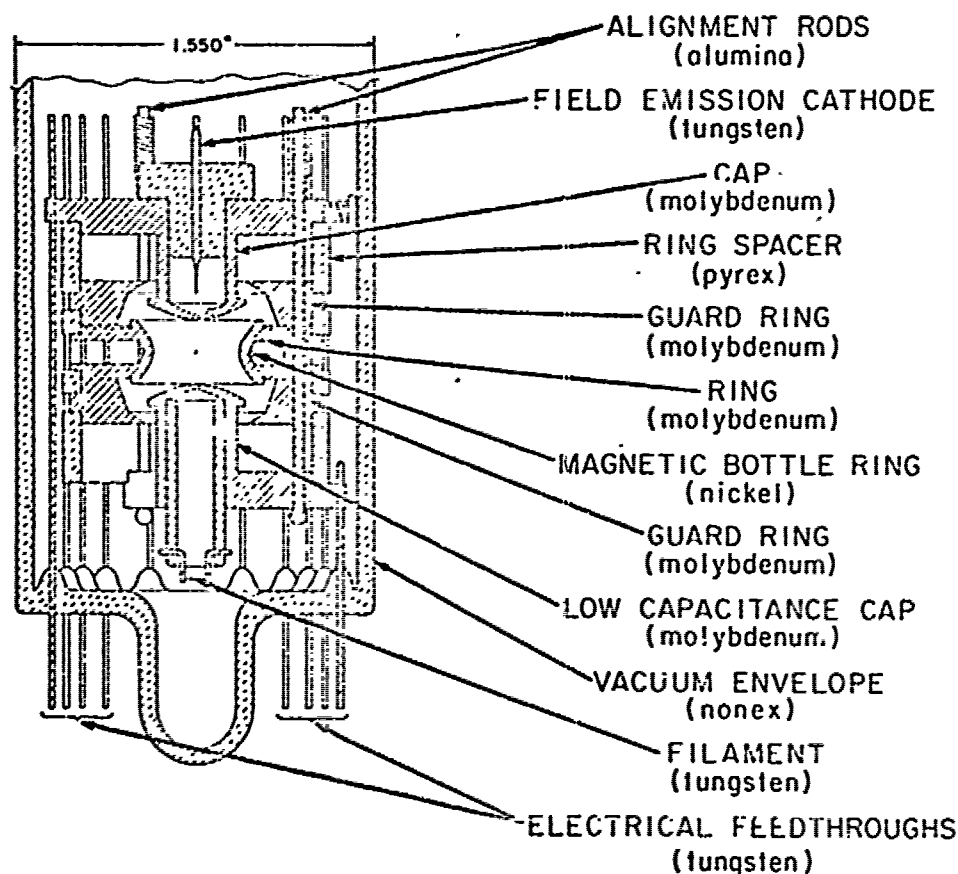
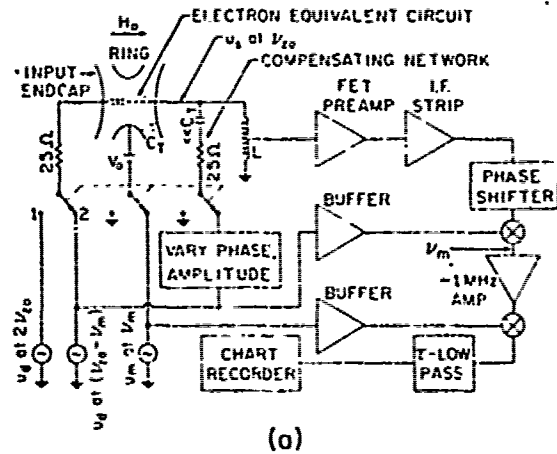
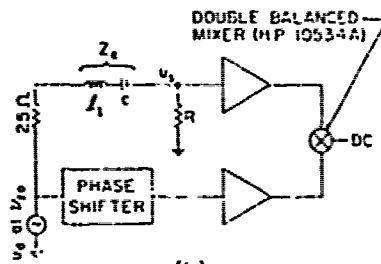

Fig. 10. Anharmonicity compensated Penning trap, from (Van Dyck et al., 1975)

for electrons or positrons (Dehmelt, 1974). In other developments Walls & Duan (1974) Fig. 13; and Walls (1974) have carried out quantitative measurements of recombination cross sections for O_2^+ , NO^+ , H_3O^+ and NH_4^+ ions practically at rest at the bottom of a Penning trap and in their vibrational ground states bombarded with an electron beam in the 0.1 to 3 eV range. The ions were stored in an apparatus similar to that shown in Fig. 1 and a detection circuit as shown in Fig. 8 was used. The decay of the ion number in the same sample was followed by repeatedly observing parallel resonance signals as shown in Fig. 9(e). In an apparatus similar to that shown in Fig. 5, McQuire and Fortson (1974), have been able to demonstrate the spindependence of the elastic collision cross section for thermal electrons and K-atoms Fig. 14. Their method is based on the shift of the frequency ν_z of the series resonant notch noise signal Fig. 9(b), occurring away from the observation window at ν' when electrons stored and thermalized in a slightly anharmonic Penning trap



(a)



(b)

Apparatus for isolating and continuously observing the forced oscillation of a single elastically bound electron. A block diagram is given in (a). Switch position 2 is for direct excitation, position 1 for parametric excitation of the forced oscillation at $\nu_{29} \approx 55.7$ MHz. In (b) an equivalent circuit is shown for switch position 2, Z_e representing the electron.

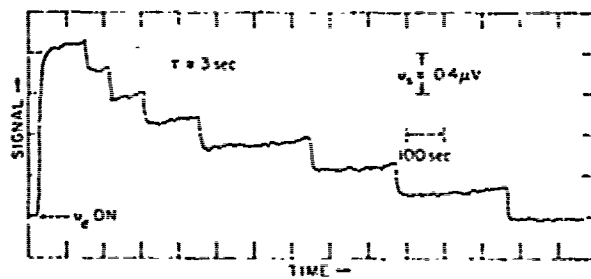

Recorder trace of forced-oscillation signal versus time. The signal at $\nu_{29} \approx 55.7$ MHz for an initially injected bunch of electrons decreases discontinuously as the electrons are successively boiled out of the trap by the drive at $\nu_{29}' \approx 54.7$ MHz. The last plateau corresponds to a single electron.

Fig. 11. Apparatus for observing forced oscillation of single electron stored in Penning trap and signal obtained with it, from (Wineland et al., 1973).

CYCLOTRON RESONANCE AT ~22GHz

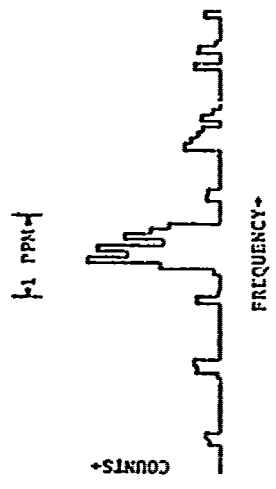

GENERALIZATION

HIGH RESOLUTION (~1 meV) (POLARIZED) ELECTRON (e-) COLLISION TECHNIQUE IN 1 neV - 10eV RANGE:
 ω_2 MOTION AT 4°K ± .3meV
 ω_2 EXCITED OFF RESONANCE TO DESIRED ENERGY
 COLLISION DETECTED BY ENERGY TRANSFER INTO ω_2 -MOTION

PARAMETRIC EXCITATION OF MONO-ELECTRON OSCILLATOR

STATIONARY AMPL ω_2 MEQ $\omega_2 \cdot \nu_{20} = \omega_2$

DRIVEN OSCILLATION AT $\nu_0/2$

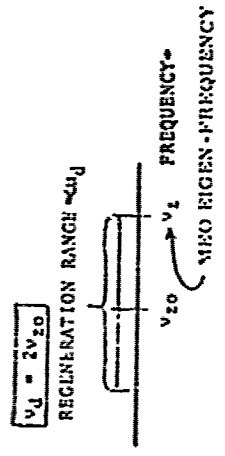

$\nu_0 > 2\nu_{20}$

REGENERATION RANGE

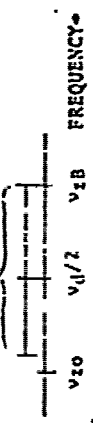

MEQ EIGEN-FREQUENCY | ν_{20} | $\nu_0/2$ | ν_{2B} | FREQUENCY
 STATE: A | | E
 DRIVEN OSCILLATION 0 | | STRONG

TRIGGER TECHNIQUE

$\nu_2 \cdot \nu_{20} = \omega_2$ SMALL AM₂: SWITCH A - B

Fig. 12. Parametric excitation of monoelectron oscillator and application for detection of single 1 - 1000 meV collisions, from (Dehmelt, 1974).

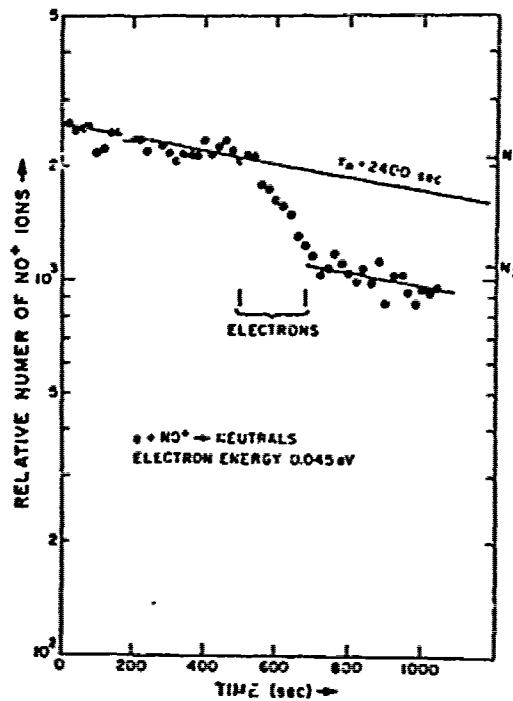

Fig. 13. Recombination data for NO^+ at an electron energy of 0.045 eV. The data from 500 to 700 s show the decay of ion signal in the presence of electrons. Measurements at other times show residual decay mechanisms, from (Wall & Dunn, 1974).

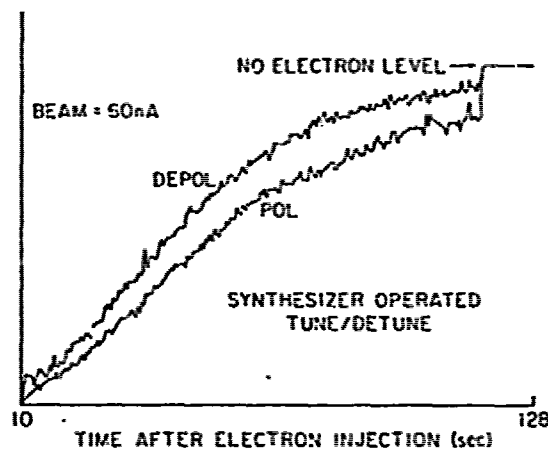

Fig. 14. Difference in electron out-of-observation-channel-diffusion signals due to collisions with potassium atoms when the potassium spin polarization is changed, (McGuire & Fortson, 1974).

diffuse radially due to e-atom collisions for a distance of ~ 0.1 cm. These authors have also observed the cooling of the electron cloud at $kT_e \ll 1$ eV due to inelastic collisions with molecules, cf. (Church & Mokri, 1971), Fig. 5(c). In the way of new schemes of some interest to collision physics it has been proposed to use laser excited resonance fluorescence at ν_1 to (A) make a single ion stored in a miniature Paul trap visible to the naked eye (Dehmelt & Toschek, 1975), (Dehmelt & Walther, 1975) and (B) freeze out the secular oscillation at ν_y of the ion in the trap completely. The latter trick is accomplished by making the ion absorb photons at the Doppler effect induced sideband frequency $\nu_1 - \nu_y$. Since reemission will occur symmetrically at $\nu_1 \pm n\nu_y$ energy is extracted from the vibrational motion on the average, (Wineland & Dehmelt, 1975c). Hereby a solution of the previously posed problem of how to make an isolated (charged) atom float at rest in free space (Dehmelt, 1967), appears to have been brought within reach. In a related scheme (Wineland & Dehmelt, 1975a, Errata & Addenda), it has been proposed to pump energy into and extract angular momentum from the magnetron motion of an electron cloud carrying out a damped oscillation at ω_z in a Penning trap by irradiating it with an inhomogeneous rf field at $\omega_z + \omega_m$, and thereby make it contract radially. There is the possibility that the underlying principle is of broader applicability and suitable for the containment of fusion plasmas.

Ion storage techniques as well as collision experiments based on them previously have been reviewed in (Dehmelt, 1967 & 1969), (Dawson & Wnetten, 1969), (Walls & Dunn, 1974), (Dehmelt, 1975), and (Dunn, 1974).

The author thanks his coworkers, Drs. David Wineland and Robert Van Dyck and Messrs. Paul Schwinberg and Frank Gorecki for reading the manuscript and Ms. Lyn Kaddox for typing it.

-
- f) An important consequence of this is that in a perfectly harmonic trap excitation of the center-of-mass axial motion of an electron cloud will not lead via e-e collisions to excitation of the center-of-mass cyclotron motion. The center-of-mass of the cloud behaves like a single particle! By contrast energy transfer via e-atom collisions will of course take place.

- CHURCH, D. A. & DEHMELT, H. G. (1969). Journ. Appl. Phys. 40, 3421.
CHURCH, D. A. & MOKKI, B. (1971). Z. Physik 244, 6.
DEHMELT, H. G. (1958). Phys. Rev. 109, 381.
DEHMELT, H. (1961). Progress Report NSF-G5955, May 1961, "Spin Resonance of Free Electrons".
DEHMELT, H. (1962), Bull. A.P.S. 7, 470.
DEHMELT, H. (1967 & 1969). Adv. Atom. & Mol. Physics, 3 & 5, (Academic Press).
DEHMELT, H. G. (1974). Bull. A.P.S. 19, 14.
DEHMELT, H. G. (1975), Proceedings, Fifth Int. Conf. on Atomic Masses and Fund. Constants, Paris (Plenum Press)
DEHMELT, H. G. & JEFFERTS, K. B. (1962). Phys. Rev. 125, 1316.
DEHMELT, H. & MAJOR, F. G. (1962). Phys. Rev. Letters 8, 213.
DEHMELT, H. & WALLS, F. (1968). Phys. Rev. Letters 21, 127.
DEHMELT, H. & TOSCHEK, P. (1975). Bull. A.P.S. 20, 61.
DEHMELT, H. & WALTHER, H. (1975). Bull. A.P.S. 20, 61.
DUNN, G. H. (1974). Atomic Physics 4, p. 575 (Plenum Press)
FISCHER, E. (1959). Z. Physik 156, 1.
GRAEFF, G., KLEMPT, E., & WERTH, G. (1969). Z. Physik 222, 201.
GRAEFF, G., MAJOR, F. G., ROEDER, R. W., & WERTH, G. (1968). Phys. Rev. Letters 21, 340.
GRAEFF, G., HUBER, K., KALINOWSKY, H. & WOLF, H., (1972). Phys. Lett. 41, 217.
JEFFERTS, K. B. (1968). Phys. Rev. Letters 20, 39.
JEFFERTS, K. B. (1969). Phys. Rev. Letters 23, 1476.

JEFFERTS, K. B. & DEHMELT, H. G. (1962). Bull. A.P.S. 7, 432.
MCQUIRE, M. D. & FORTSON, E. N. (1974). Phys. Rev. Letters 33, 737.
RICHARDSON, C. B., JEFFERTS, K. B., & DEHMELT, H. G. (1968). Phys. Rev. 165, 80.
SCHUESSLER, H. FORTSON, N. & DEHMELT, H. (1969). Phys. Rev. 187, 5.

VAN DYCK, R., EKSTROM, P. & DEHMELT, H. (1975). Bull. A.P.S. 20, 492.
WALLS, F. (1970). Thesis, University of Washington.
WALLS, F. & DUNN, G. (1974). Physics Today 27, No 8, 30.
WINELAND, D., EKSTROM, P., & DEHMELT, H. (1973). Phys. Rev. Lett. 31, 1279.
WINELAND, D., & DEHMELT, H. (1975a). Int. Journ. Mass Spectroscopy & Ion Phys. 16, 338.
WINELAND, D., & DEHMELT, H. (1975b). Journal Appl. Phys. 46, 919.
WINELAND, D. & DEHMELT, H. (1975c). Bull. A.P.S. 20, 637.

AMCO - 5

CINQUIÈME CONFÉRENCE INTERNATIONALE
SUR LES MASSES ATOMIQUES
ET LES CONSTANTES FONDAMENTALES

*FIFTH INTERNATIONAL CONFERENCE
ON ATOMIC MASSES AND FUNDAMENTAL CONSTANTS*

2-6 Juin 1975

Maison de la Chimie - Paris, France

A PROGRESS REPORT ON THE G-2 RESONANCE EXPERIMENTS

Hans G. Dehmelt

University of Washington

Seattle, Washington 98195, U.S.A.

INTRODUCTION

The spin resonance experiments on slow free electrons in vacuum have a long history. In 1953 Bloch proposed to trap electrons in an electric potential well of depth $\sim 10^{-5}$ V and unspecified shape superimposed upon a magnetic field of ~ 1000 G. Cyclically the latter could be made so inhomogeneous that the effective magnetic field seen by all electrons not in the lowest, unmagnetic Rabi-Lansau level would overcompensate the electric well. Thereby, only those in the lowest level would be retained. Spin- or cyclotron-transitions to the next higher levels induced subsequently would be signalled by loss of the electrons. The levels referred to are given by $E = (2n + 1 + g_s \mu_B / \hbar) \mu_B \hbar$, with $n = 0, 1, 2, \dots$ and $s = \pm 1/2$, (Rabi, 1928). Also at Stanford in connection with their cyclotron-resonance work in which trapping was carefully avoided Franken & Lichten showed in 1956 that a small external electric field should shift the cyclotron frequency $\omega_c \approx 2\pi\nu_c$ by $\delta\omega_c = \delta\epsilon_{zz}/\omega_c$. This suggested that the Penning (1937) trap in the form described by Pierce (1949) should be well suited for the simultaneous measurement of ω_c and of the spin resonance frequency $\omega_s \approx 2\pi\nu_s$ on stored electrons. For such a trap the axial field gradient $\delta\epsilon_{zz}$ and $\delta\omega_c$ are constant throughout its volume and $\delta\omega_c = -\nu_m$ may be determined by measuring the axial oscillation frequency $\omega_z \approx 2\pi\nu_z$ or the magnetron (drift) frequency $\omega_m \approx 2\pi\nu_m$ on the electrons in situ. This allows the use of well depths which comfortably exceed the contact potential uncertainties of .1 - 1 V commonly encountered in radio tubes. Consequently, work with -2 V deep Penning traps was begun at the University of Washington. Axial resonances at $\nu_z \approx 2.7$ MHz about 10 kHz wide, and -15 kHz wide cyclotron resonances at $\nu_c = 81$ MHz were observed and efforts to detect the spin resonance of the stored

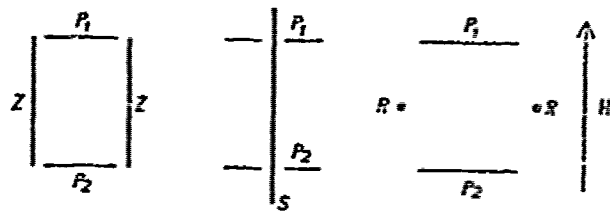

Fig. 1. Verschiedene Typen von Glimmentladungsröhren für sehr niedrigen Druck. P_1 und P_2 Platten (Kathode), Z = Zylinder, S = Stab, R = Ring (Anode).

(PENNING, 1937)

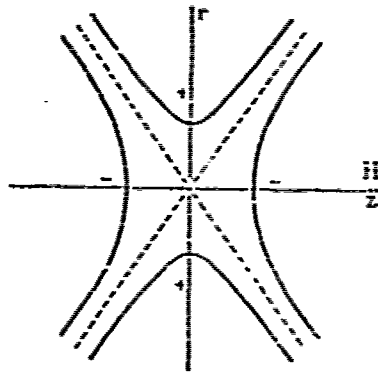

FIG. 4.7—Electron motion between hyperbolic electrodes may be limited to a certain region by use of an axial magnetic field.

(PIERCE, 1949)

electrons via interaction with a polarized Na-beam were initiated by 1959. In the course of this work the relation $2\omega_c\omega_m = \omega_s^2$ was demonstrated experimentally. Expressions were derived for the thermalization time $\tau_{IT} = (hM\omega_0^2)/(e^2R_g)$ of a single ion of mass M and initial energy W_{IO} oscillating inside a trap of cap separation $2z_0$ interacting with a tuned circuit of shunt resistance R_g and also the power signal-to-noise ratio $S/N = W_{IO}/kT$ available in the tuned circuit with an observation time $\sim \tau_{IT}$ was obtained (Dehmelt 1961, 1962). As no spin resonance was observed it was decided to go to smaller, deeper traps, $\nu_z = 60$ MHz, in higher fields, $\nu_c = 3 - 22$ GHz, and to study thermalization and relaxation processes occurring in the cloud, which were feared to interfere with the detection of the spin resonance. Of special interest here were interactions between the electrons, with the tuned circuit and, via Majorana flops, with (modulated) magnetic field gradients, e.g. (Kleppner et al. 1962). The hope was to use relaxation effects to provide a link between spin and cyclotron motion that spin resonance might be detected by heating of the cloud (Dehmelt & Walls 1968), eliminating the need for the Na-beam. Having adsorbed a number of former members of the Washington ion-rf-spectroscopy group the Bonn/Mainz group entered the field very vigorously in 1965, taking up the Penning trap/Na-beam combination after spin resonance of He^+ in a Paul trap polarized by spin exchange with a Cs beam had been demonstrated previously (Dehmelt & Major, 1962; Fortson, Major & Dehmelt, 1966). This group was the first to report spin and $g-2$ resonances (Fortson, Graeff, Major, Roeder and Werth, 1968; Graeff, Klempt and Werth, 1969). The work at the three labs prior to 1972 is the subject of a chapter in the 1972 review article of Rich & Wesley. Part of it is also covered in the 1967 and 1969 review articles on the rf spectroscopy of stored ions by the author. Earlier work has been reviewed by Hughes (1959) and Farago (1965).

THE STANFORD EXPERIMENT

Any experiments with slow electrons are beset with many problems unfamiliar to experimentalists well versed in the handling of "stiff" and much more popular high energy beams. It is all the more surprising that the remarkable data which have been reported for the Stanford electron-positron free-fall apparatus (Fairbank et al., 1973) have not stirred the interest of experimentalists in this field more. It has been proposed (Knight, 1965) to adapt this time-of-flight apparatus for which energy resolutions of $\sim 10^{-10}$ eV at 4°K and $\sim 10^{-5}$ eV at 300°K have been reported to simultaneous measurement of spin and cyclotron resonances on electrons in the lowest Rabi-Landau level (Rich & Wesley, 1972). Land & Raith (1974) have described experiments with a somewhat similar time-of-flight apparatus developed for collision studies and report a resolution of $\sim 5 \times 10^{-3}$ eV at 300 K.

SINGLE HOT ION INTERACTING WITH TUNED CIRCUIT

THERMALIZATION OF ION

$$W_T = kT_0 + (W_{I0} - kT_0) \exp(-t/\tau_{IT})$$

$$\tau_{IT} = (4M z_0^2) / (e^2 R_s)$$

OPTIMUM SIGNAL TO NOISE RATIO

INITIAL ENERGY OF ION, W_{I0} , FLOWS SLOWLY INTO TANK, FAST INTO BATH, $\tau_{IT} \gg \tau_{TB}$. RETAINED IN TANK FOR INTERVAL $\approx \tau_{TB}$, $W_T \approx (\tau_{TB}/\tau_{IT}) W_{I0}$. THERMAL FLUCTUATIONS OF TANK ENERGY FOR OBSERVATION TIME $\approx \tau_{IT}$ AVERAGE OUT TO $\Delta W_T \approx (\tau_{TB}/\tau_{IT}) kT_0$, $S/N = W_T / \Delta W_T$;

$$S/N \approx W_{I0} / kT_0$$

(DEHMELT, 1962)

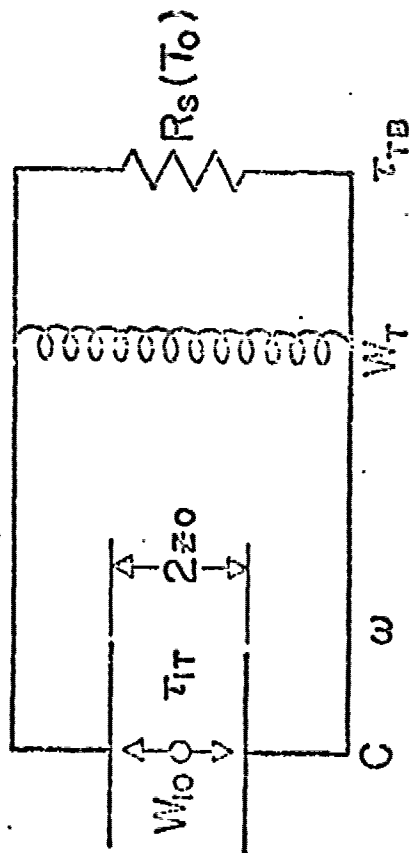

NUMERICAL EXAMPLE

- $M = 100 M_H$; $2z_0 = 0.5 \text{ cm}$
- $C \approx 10^{-11} \text{ F}$; $Q = 100$
- $\omega \approx 5 \times 10^5 \text{ CPS}$; $R_s \approx 2 \times 10^7 \Omega$
- $\tau_{IT} \approx 13 \text{ sec}$; $W_{I0} \approx 3 \text{ eV}$
- $S/N \approx 100$, $kT_0 \approx 0.03 \text{ eV}$

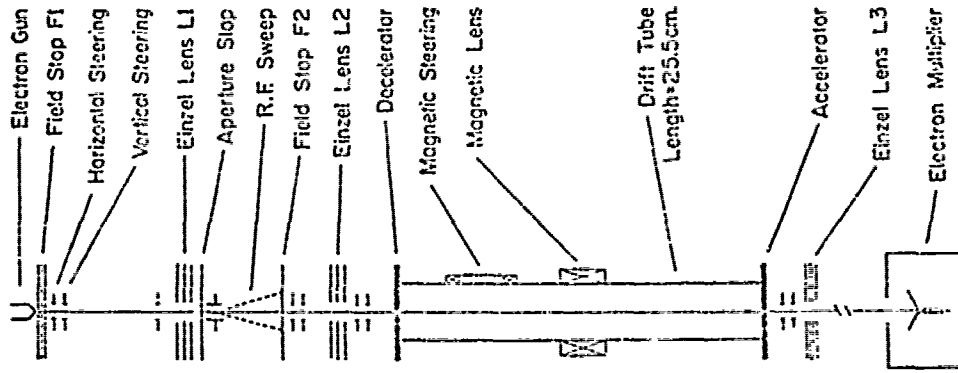

FIG. 2. Scale drawing of the electron time-of-flight spectrometer; radial dimensions enlarged by a factor of 2.

(LAND & RAJTH, 1975)

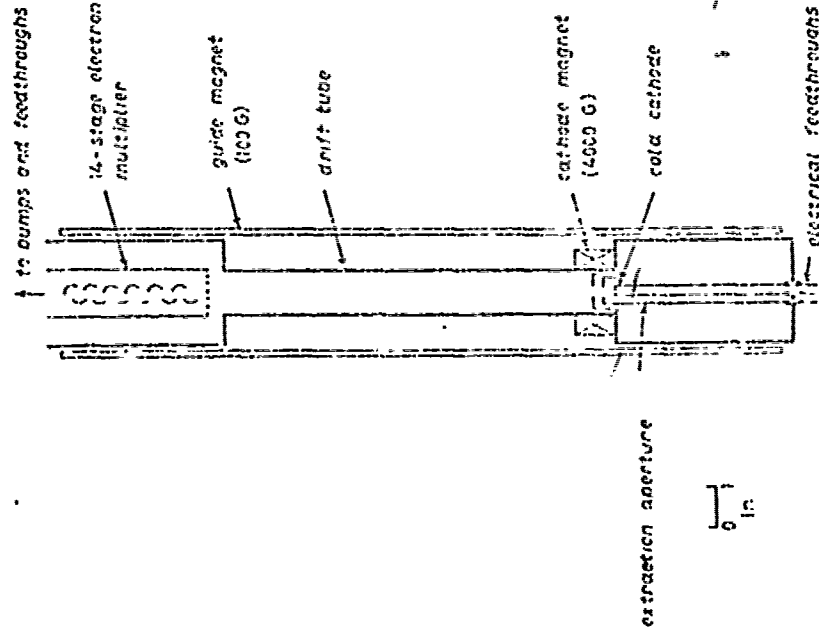

Fig. 1. - The first version of the free-fall apparatus. Vacuum pumps, Dowars, electronic wires and transfer tube are not shown.

(FAIRBANK, ET AL., 1973)

THE BORN/MAINZ EXPERIMENTS

Using the same Penning trap/polarized Na-beam apparatus but noise-instead of ejection-thermometry Church & Mokri (1971) have repeated the g-2 resonance experiments of Graeff, et al. (1969) relying on the spin dependence of the cooling of the electron cloud associated with impact excitation of the Na D-lines. Graeff et al. (1972) have monitored the Na-beam emerging from the trap for spin flips it might have undergone upon interacting with the electron cloud. The spin resonance has been observed in this way. Kienow, et al. (1974) have introduced a superconducting 65 kG Magnet and a new mode of ejection-thermometry relying on particle counting. As the depth of the trapping well is gradually lowered electrons of lower and lower energy leave the trap through a hole in one end cap, are accelerated and counted. The authors have tested their apparatus by determining a sequence of energy distributions as the stored cloud is allowed to cool via spontaneous emission of cyclotron radiation for increasing intervals. Through the heating of the cloud under cyclotron excitation they have also observed cyclotron signals of 1 ppm width. In a separate experiment also using a superconducting magnet and introducing some important modifications Graeff et al. (1975) are reviving the (1953) proposal of Bloch. The authors propose to trap electrons in a Penning trap, thermalize their axial and cyclotron motions at 4°K, eject them by adiabatic reduction of the well depth and pass them through the fringing fields along the axis of the superconducting solenoid. About half of the **electrons** should be in the lowest unmagnetic level and should therefore experience no acceleration "gliding down" this magnetic "potential hill". Changes in the fraction of electrons in higher, magnetic, Rabi-Landau levels following suitable excitation are expected to show up when the electrons emerging from the fringing field are analyzed by time-of-flight spectrometry.

THE WASHINGTON EXPERIMENTS

Based on experiments in which a low signal/noise ratio and lack of time prevented doing an ample number of runs and controls, Walls & Stein (1973) have published preliminary measurements of g-2 in an electron gas at 80°K by means of a **bolometric** technique. In this technique (Dehmelt & Walls, 1968) the temperature of the cloud is inferred from noise measurements on an LC circuit coupled to the axial motion. This noise thermometry is used to detect heating of the cloud caused by excitation of the cyclotron motion **brought** about by sequentially inducing spin- and g-2 transitions. The **inhomogeneous** magnetic rf field inducing the g-2 transitions was **created** by opposing loop currents flowing in the especially cut and **lattice** ring electrode (Walls 1970). The measured distribution **of this** field near the center of the trap, could be approximated by a **gradient**

$$\partial H_x / \partial x = -\partial H_z / \partial z, \quad \partial H_y / \partial y = 0.$$

An electron moving in a **cyclotron**

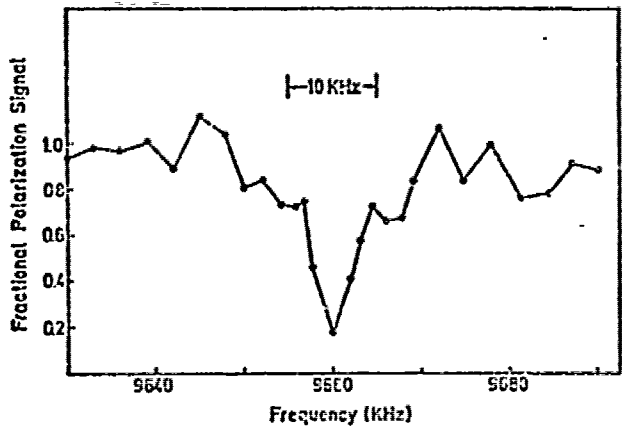

(CHURCH & MOKRI, 1971)

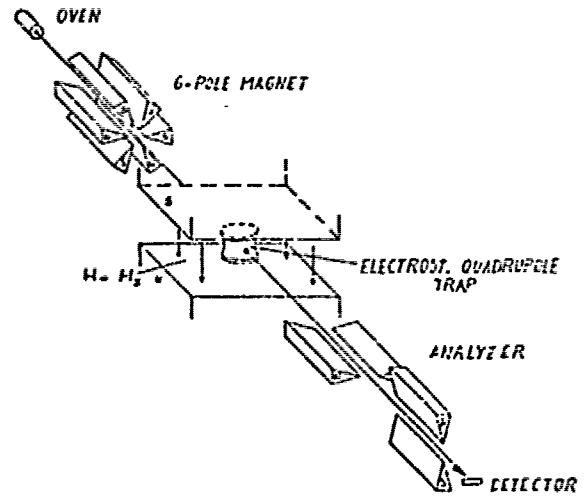

(GRAEFF & AL., 1972)

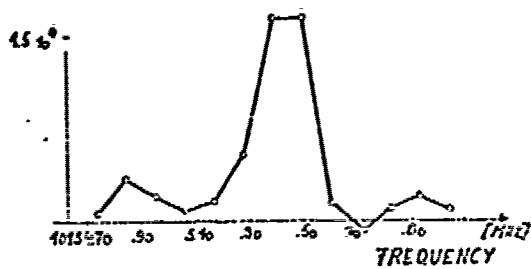

(GRAEFF & AL., 1972)

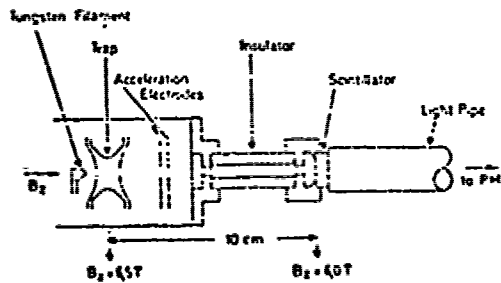

Fig. 1. Schematic diagram of electron trap and detection system.

(KIENOW ET AL., 1974)

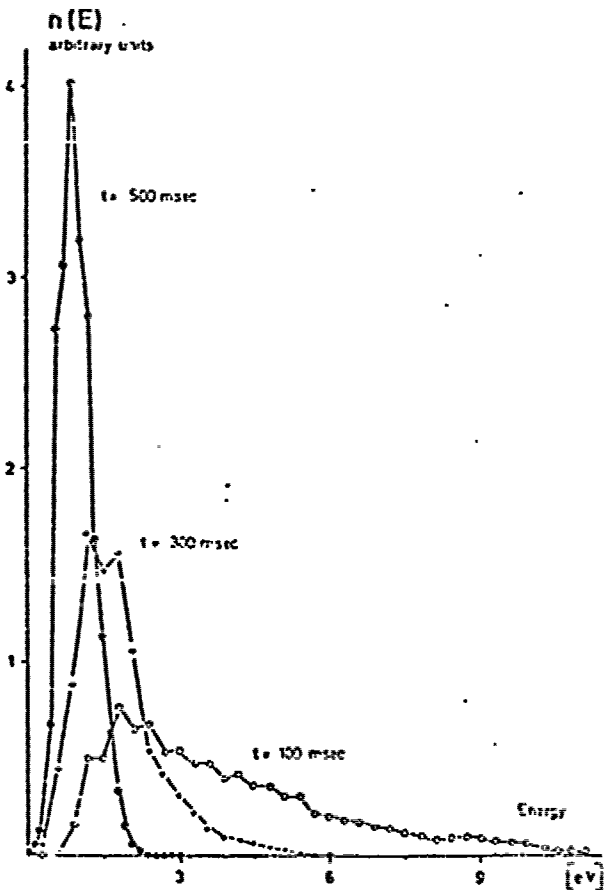
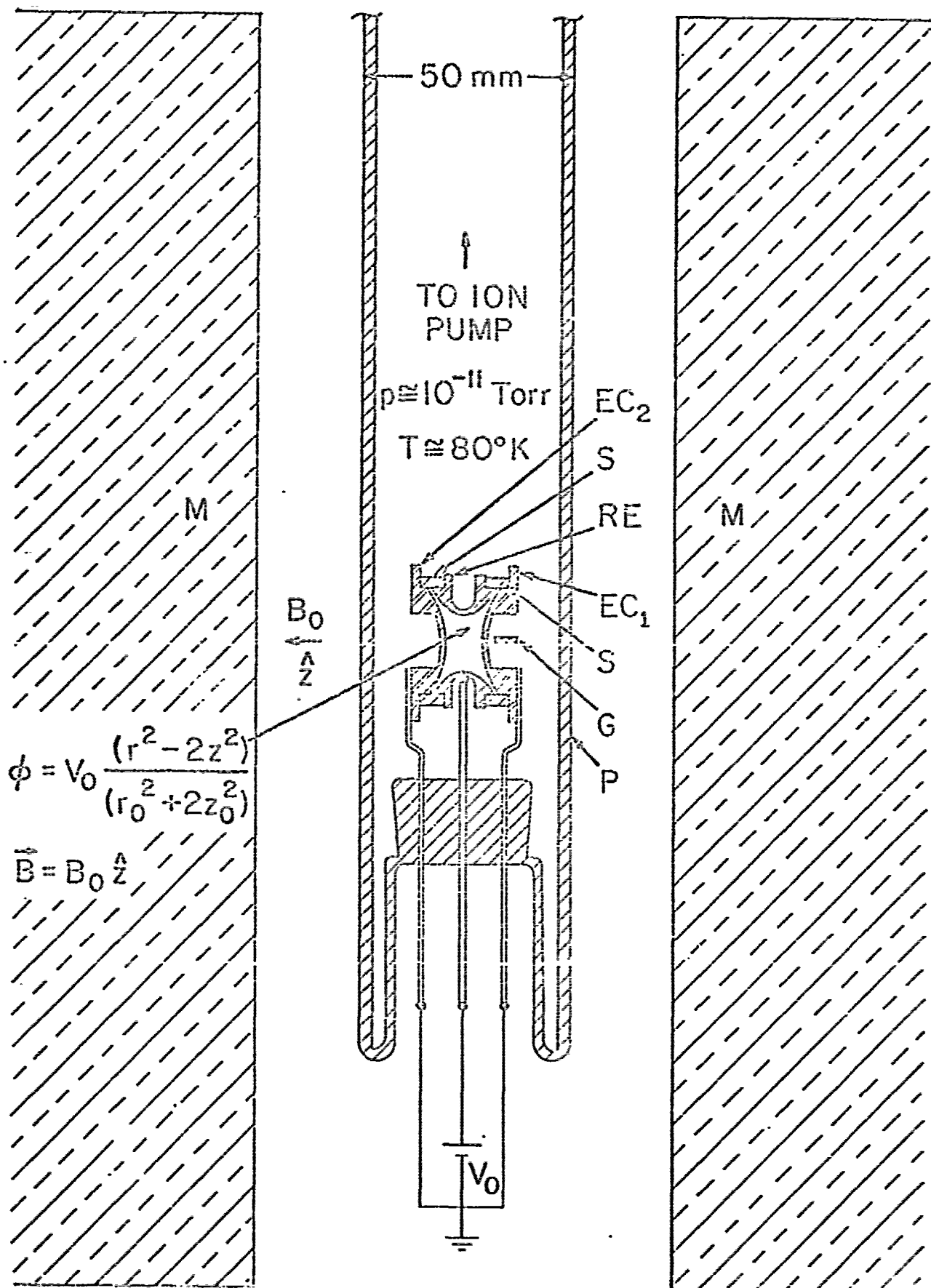
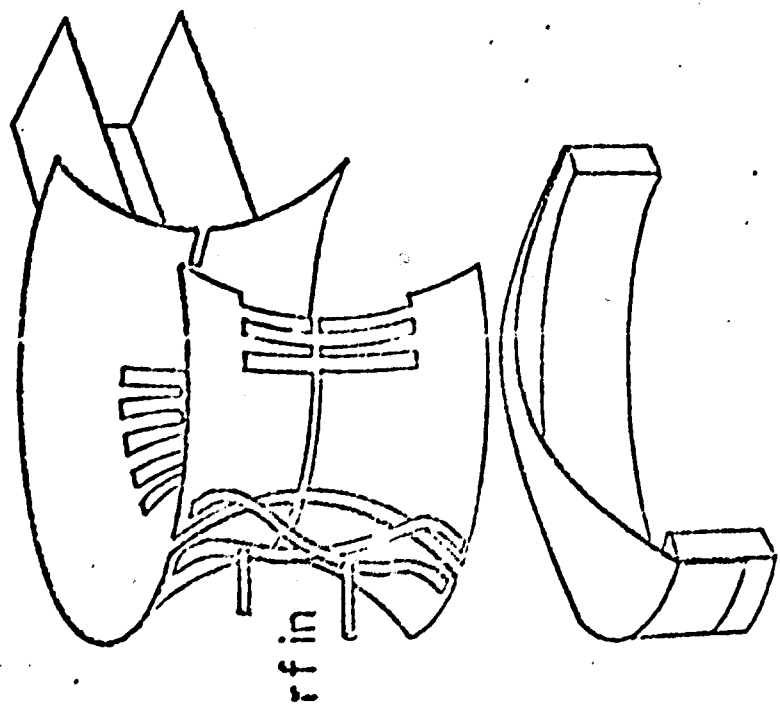

Fig. 2. Energy distribution of trapped electrons at 6.5 tesla after different trapping times t .

(KIENOW ET AL., 1974)



(WHEELAND & DEHMELT, 1975B)



1cm

(WALLS, 1970)

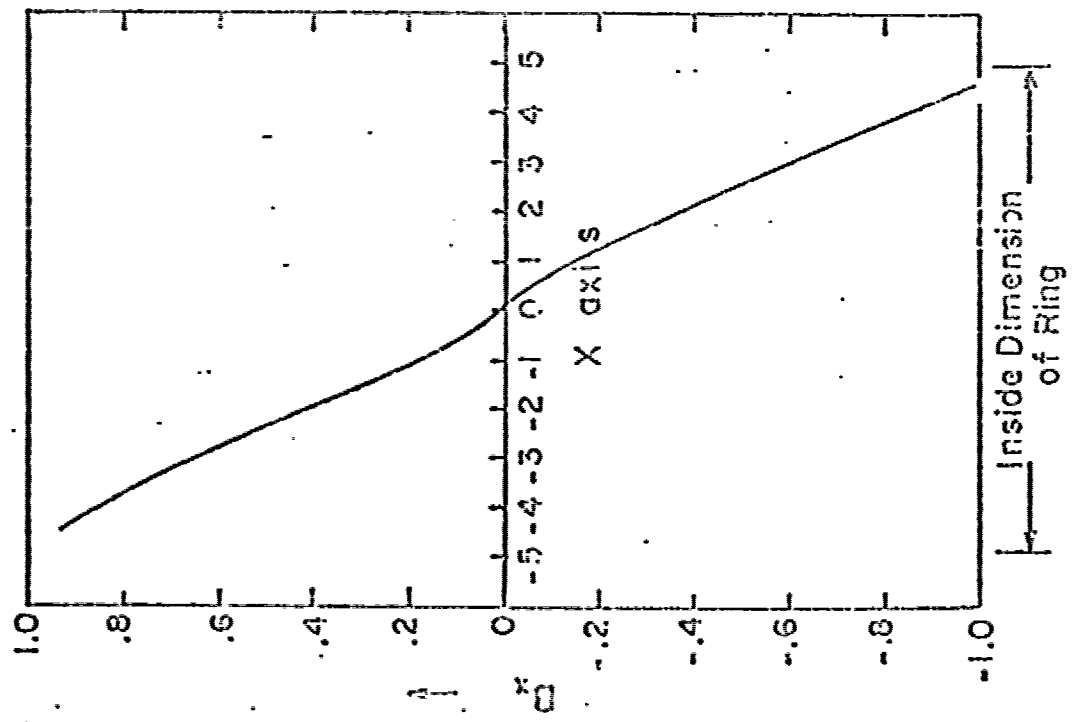
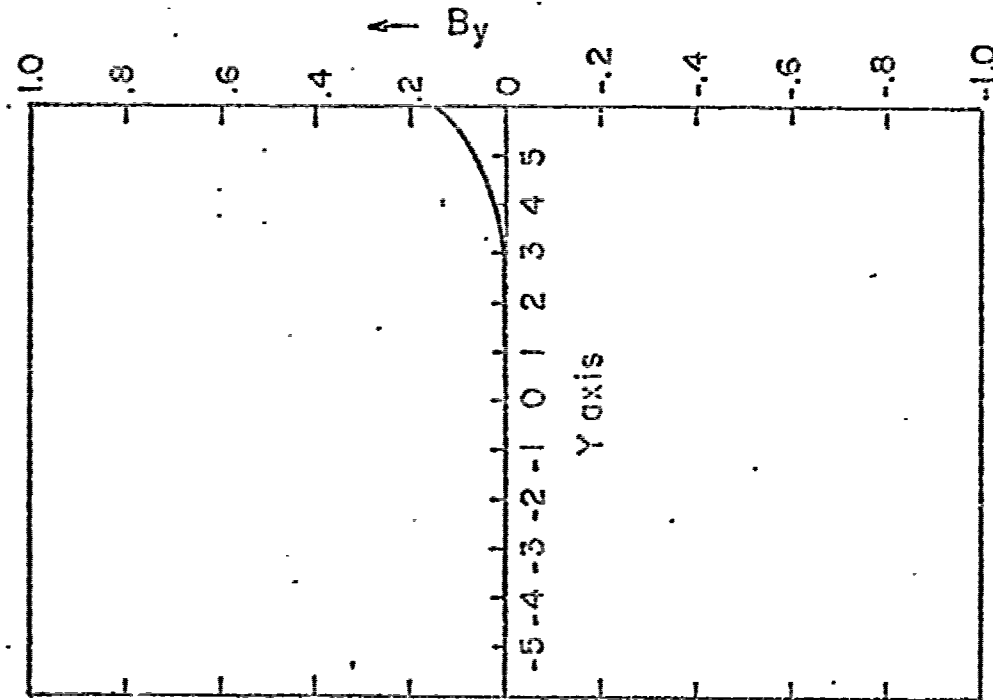

(WALLS, 1970)

orbit of radius r_c will consequently see an oscillating field $r_c (\partial H_x / \partial x) \cos \omega_c t$. Since $(\partial H_x / \partial x) \approx \cos \omega_d t$ this field will consist of two side bands at $\omega_c \pm \omega_d$ and will induce spin transitions when one chooses $\omega_c + \omega_d = \omega_p$. Values $\partial H_x / \partial x \approx 10$ G/cm were practical, yielding with $r_c = 5 \times 10^{-6}$ cm Rabi frequencies of about 600 Hz. Graeff & al. (1969) and Church & Kokri (1971) have used a different configuration in which the orbiting electron sees a field rotating at ω_c whose amplitude is $\propto \cos \omega_d t$. Both of these fields violate Byrne's (1963) unnecessary restriction that fields capable of inducing the $g=2$ transition should be independent of z . (Byrne has proposed to use the leading, z -independent term of the circular H-field present in a special coaxial cavity. However, even for $(\text{curl } H)_z \approx 20$ mG/cm and a Rabi frequency of ~ 1 Hz the accompanying electric field $E_z = \lambda_d (\text{curl } H)_z$ assumes the value of ~ 1 kV/cm! at $\nu_d = 25$ MHz.) Subsequent experimental efforts were directed towards increasing the efficiency of the resonant spin/ $g=2$ heating and of the bolometric detection. Computer simulation indicated that alternating adiabatic fast passage spin reversals and $g=2$ frequency π -pulses of a combined 2 msec duration should result in a quick drop of the spin temperature to $\sim 8^\circ\text{K}$ and an increase in the cloud temperature of $\sim 10^\circ\text{K}/\text{sec}$ (Dehaelt & Ekstrom, 1973a). The interaction of the tuned circuit with the electron cloud was analyzed in terms of an equivalent L_{eq} series resonant circuit shunting a real $100 \nu_d^2$ parallel resonant circuit. The equivalent inductance for a single electron $L_1 = nL$, n the electron number, is a constant of the trap which for our parameters had the value $L_1 = 8000$ Hy. Drastic effects of the cloud on the noise spectrum of the tuned LC circuit demonstrated itself. The width of the notch observed for $\nu_d = \nu_d^1$ allowed a convenient determination of n . From the viewpoint of calorimetry of special interest is the sharp noise peak observed at $\nu_d^2 \nu_d^1$. It is due to the parallel resonance associated with the cloud and the area under the resonance is proportional to $n \times$ the cloud temperature. At 80°K the corresponding electron cloud calorimeter is characterized by a heat input integration time of ~ 5 s and a temperature sensitivity of about $1/2^\circ\text{K}$ for $n \approx 10^4$. (Dehaelt & Wineland, 1973, Wineland & Dehaelt, 1975b). Assuming with Gardner (1951), Franken & Liebes (1956) and Fischer (1959) that the electric shifts of cyclotron and axial resonance frequencies should reflect fields from identical neighbors one might feel that a narrow observed relative axial line width of $\sim 10^{-6}$ should indicate a comparable ~ 1 Hz uniformity of the cyclotron resonance shift equal to $\nu_m \approx 10^5$ Hz. However, this is not the case (Wineland & Dehaelt, 1975a). The equations of motion of a single particle in a Penning trap under forced cyclotron/axial excitation $f_x(t)/f_z(t)$ may be written

$$m\ddot{x} - m\omega_z^2 x/2 + m\omega_c \dot{y} = f_x(t), \quad -m\omega_z^2/2 = e\phi_{xx}$$

$$m\ddot{y} - m\omega_z^2 y/2 - m\omega_c \dot{x} = 0, \quad -m\omega_z^2/2 = e\phi_{yy}$$

$$m\ddot{z} + m\omega_z^2 z = f_z(t), \quad m\omega_z^2 = e\phi_{zz}$$

Best Available Copy

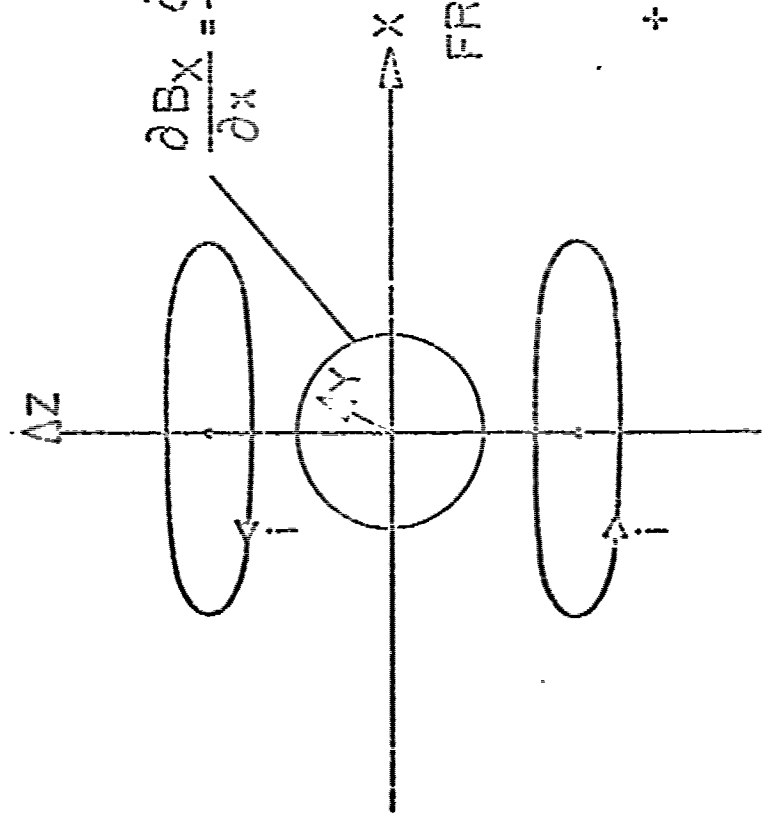

$$\frac{\partial B_x}{\partial x} = \frac{\partial B_y}{\partial y} = -\frac{1}{2} \frac{\partial B_z}{\partial z} \approx \text{const.}$$

XY PLANE

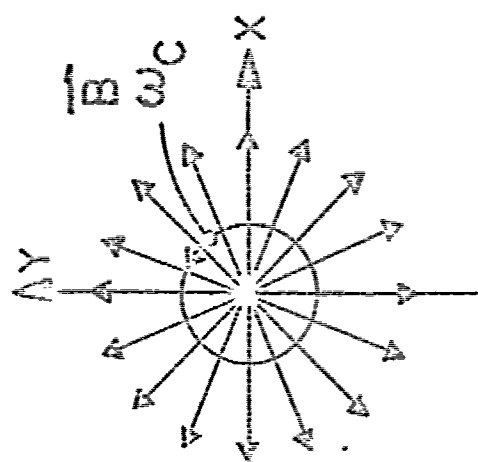

LAB FRAME

FRAME AT $+\omega_C$

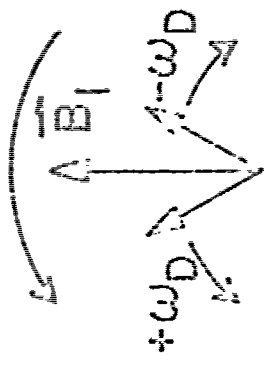

$$B_1 = B_{10} \cos \omega_D t$$

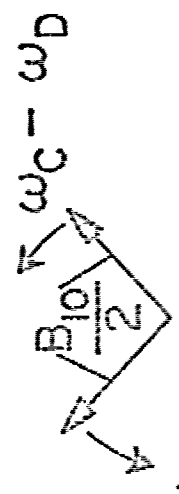

$$\omega_C + \omega_D = \omega_S$$

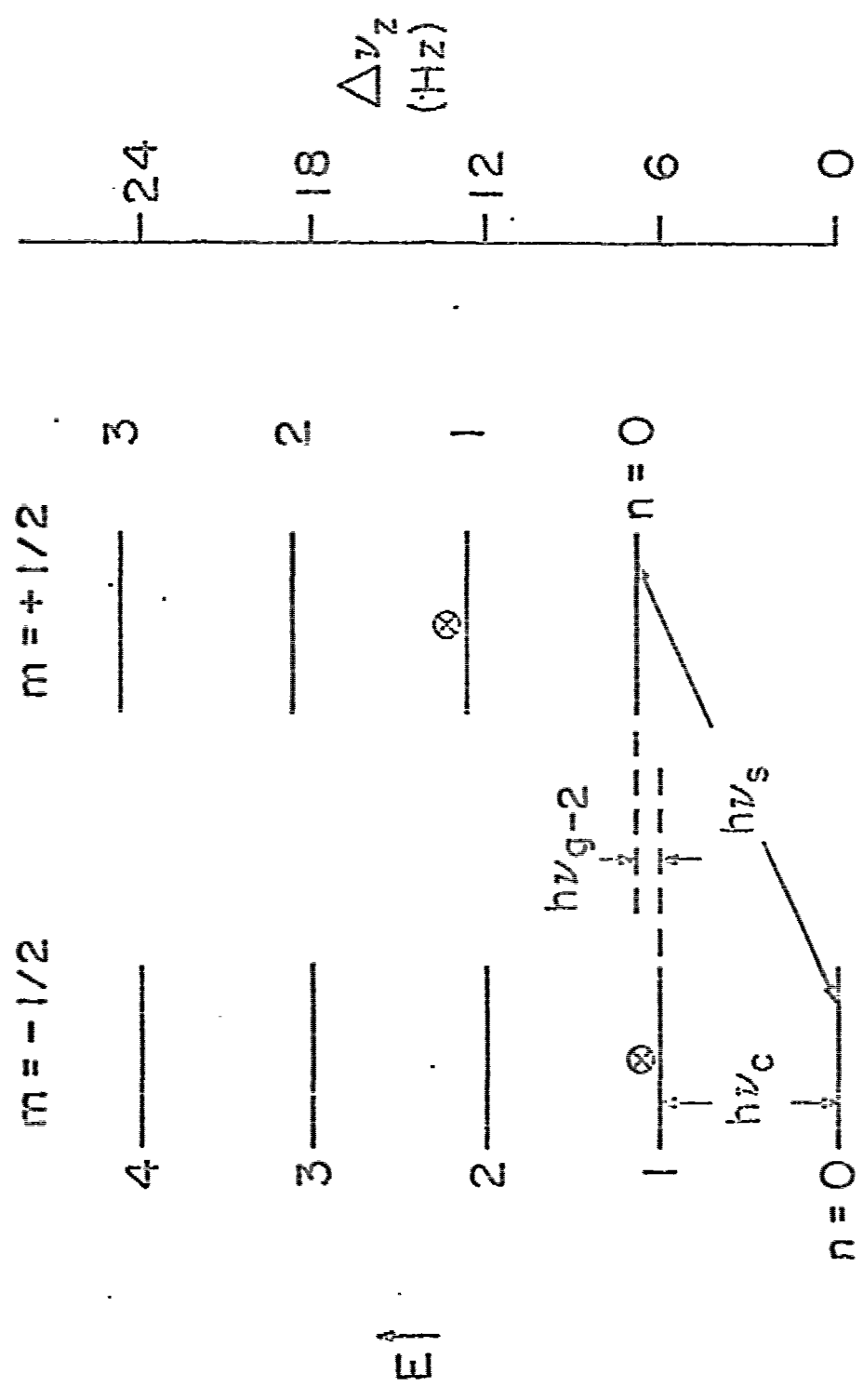

$H_0 = 60 \text{ KG}$ $T_0 = 8^\circ \text{ K}$ $\Delta\nu_z = (1 + 2n + gm) 3 \text{ Hz}$

(DEHMELT & EKSTROM, 1973)

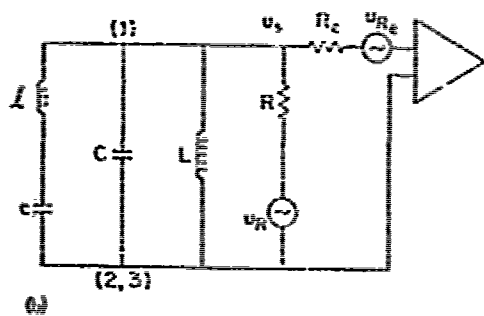
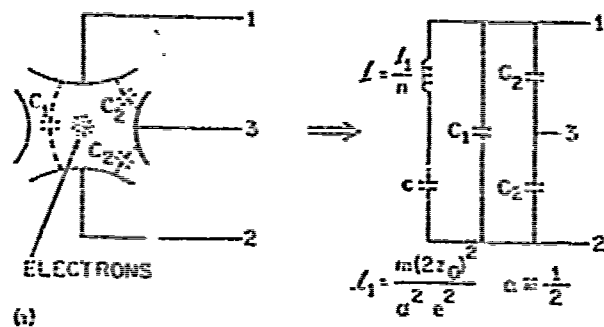
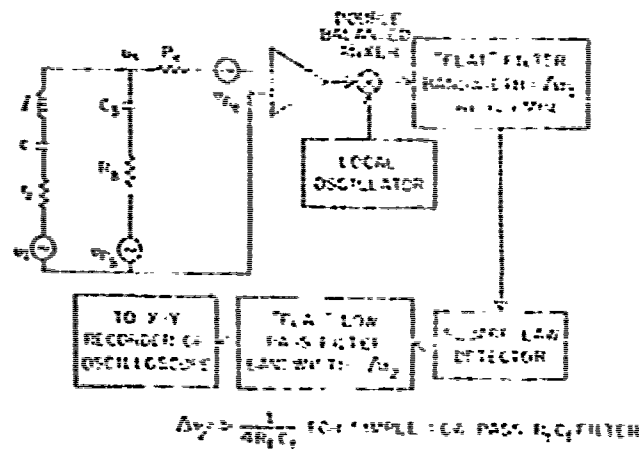

FIG. 3. Electrical equivalent representations of electrons in the Penning trap structure. (a) Electrical representations of electrons in the Penning trap and electrical equivalent representation. (b) Electrical equivalent representation of electrons, Penning trap, and external circuitry having noise voltages associated with trap resistance R and Heitlinger's transistor input noise resistor R_n .

(WINELAND & DEHMELT, 1975B)



$$\Delta \nu_2 \approx \frac{1}{4R_1 C_2} \text{ FOR SIMPLE RC PASS FILTER}$$

FIG. 6. Model for electron interacting with trap circuit showing block diagram of detection system.

(WINELAND & DEHMELT, 1975B)

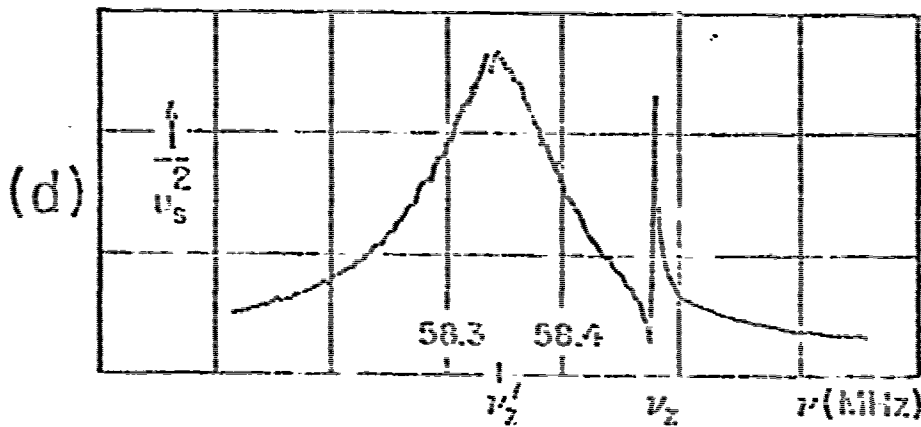
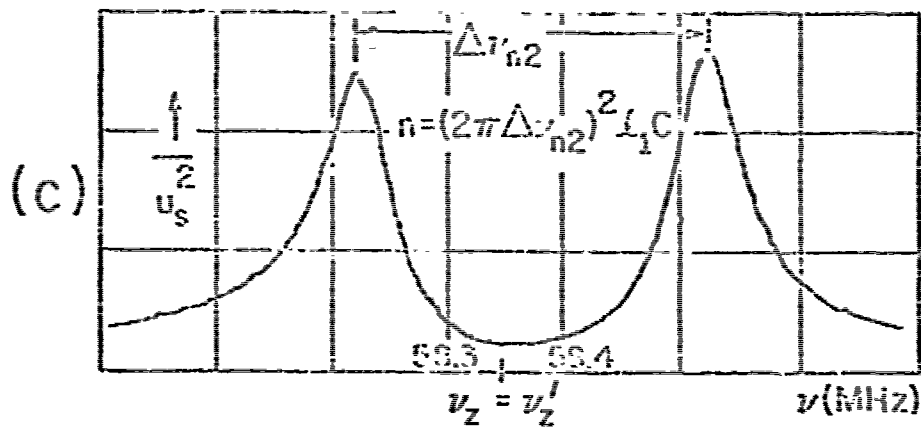
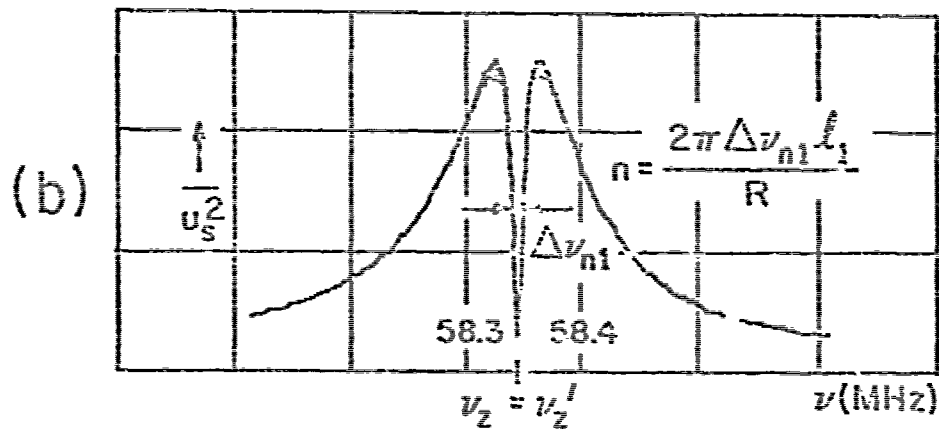
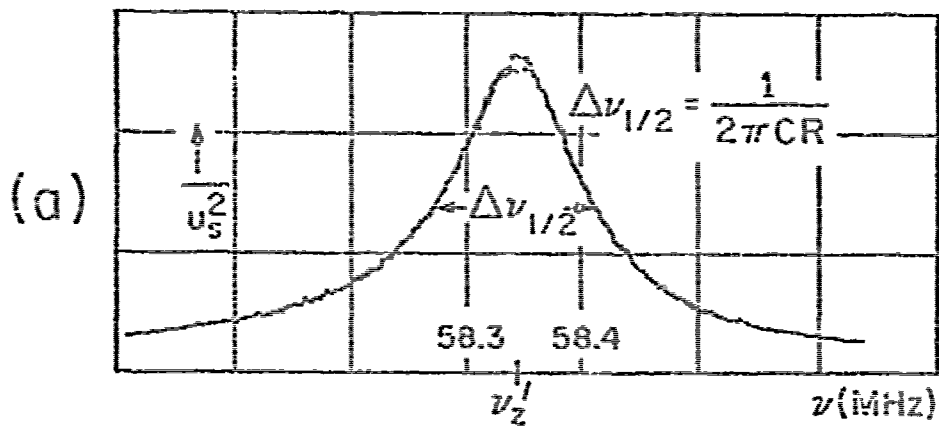

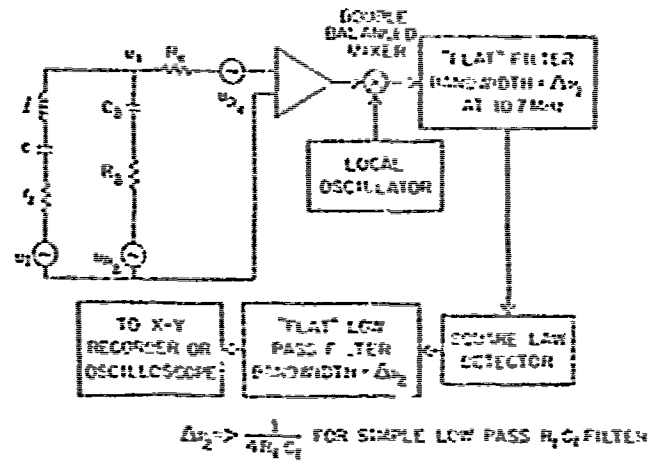
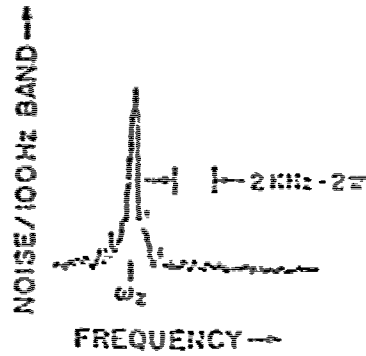

FIG. 6. Model for electrons interacting with trap circuit showing block diagram of detection electronics.

(WINELAND & DEHMELT, 1975B)



(WINELAND & DEHMELT, 1975A)

Electrostatic interactions between like particles do not shift or broaden the cyclotron resonance at $\omega_c - \omega_m$ or the axial resonance at ω_z , $\omega_c = eH_0/mc$, $\omega_c \omega_m - \omega_z^2 = \omega_z^2/2 = -e^2 z z / m$. Rather, from the equation of the z-motion of two interacting particles

$$m\ddot{z}_1 + m\omega_z^2 z_1 = F_{z12} + f_z(t), \quad m\ddot{z}_2 + m\omega_z^2 z_2 = F_{z21} + f_z(t)$$

it follows by addition that the center of mass coordinate $Z_c = (z_1 + z_2)/2$ obeys the same equation as a single particle, $m\ddot{Z}_c + m\omega_z^2 Z_c = f_z(t)$. The same argument may be extended to the x and y coordinates and to an arbitrary number of identical particles. Unfortunately, this is not so for the g-2 resonance occurring in a cloud at $\omega_B = \omega_c + \omega_{ml}$. Here the individual electron spin due to its thermal cyclotron motion at $\omega_c - \omega_{ml}$ through the applied inhomogeneous magnetic field alternating at $\omega_c + \omega_{ml}$ sees a sideband at the spin resonance frequency $\omega_B = \omega_c + \omega_{g-2}$ (Dehmelt and Walls, 1963). However, $\omega_{ml} \neq \omega_m$ now reflects the micro-environment of the electron focused upon. The presence of strong e-e interactions in usable clouds has been demonstrated *ad oculos* by parametric excitation at $2\nu_z$ of a mode in which one half of the cloud oscillates out-of-phase against the other half, suggesting $|\omega_{ml} - \omega_m|/\omega_m = .01-0.1$. Nevertheless for the center-of-mass mode a line width $\Delta\nu_z = 600$ Hz at $\nu_z = 60$ MHz, has been realized. The cause of the residual width is most likely subharmonicity of the trapping potential. With a trap design incorporating guard rings newly developed by Van Dyck et al. (1975) it has been possible to null out the biquadratic terms in the potential and to reduce the width of the line to ~ 20 Hz by applying appropriate voltages to the guard rings.

In view of the above developments a single electron contained in a harmonic well, free from complex space charge shifts began to look more and more attractive. As a first step experiments were begun to continuously observe the axial excitation of a single electron (Wineland, Ekstrom & Dehmelt, 1973). Cloud experiments had indicated a trap subharmonicity $\Delta\nu_z/\nu_z = 50$ kHz/eV. Sidestepping associated frequency pulling problems excitation at the zero-amplitude eigenfrequency ν_{z0} of the electron was chosen. In the circuit used the drive u_d was applied to one cap which via the equivalent impedance Z_c of the series resonant electron was connected to the other cap. As u_d is increased from 0 to 2mV the eigenfrequency ν_z grows by ~ 7 kHz and the imaginary part of the impedance Z_c increases from 0 to $4\pi \times 7$ kHz $\times 10^{22} \Omega$, an rf current $i_{d1} = u_d/Z_c = 5 \times 10^{-12}$ A flows through the LC circuit of shunt impedance $R = 100$ k Ω connected to the output cap developing a signal $u_s = .3$ μ V and exciting an electron oscillation of energy $W_1 = 2\pi i_{d1}^2/2 = .2$ eV. The experimental problems associated with the unfavorable ratio $u_s/u_d = 10^{-8}$ were solved by slightly modulating ν_z at $\nu_{mod} = 1$ MHz, driving the electron oscillation on the weak $\nu_{z0} - \nu_{z0d}$ side band but synchronously detecting the strong ν_{z0} carrier. Drawing upon the cloud techniques sketched earlier about 10 electrons were injected. When u_d was

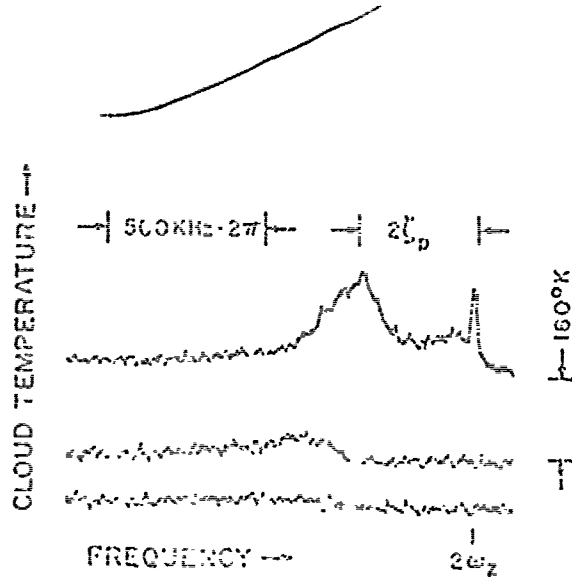

(WINNBLAND & DEHMELT, 1975A)

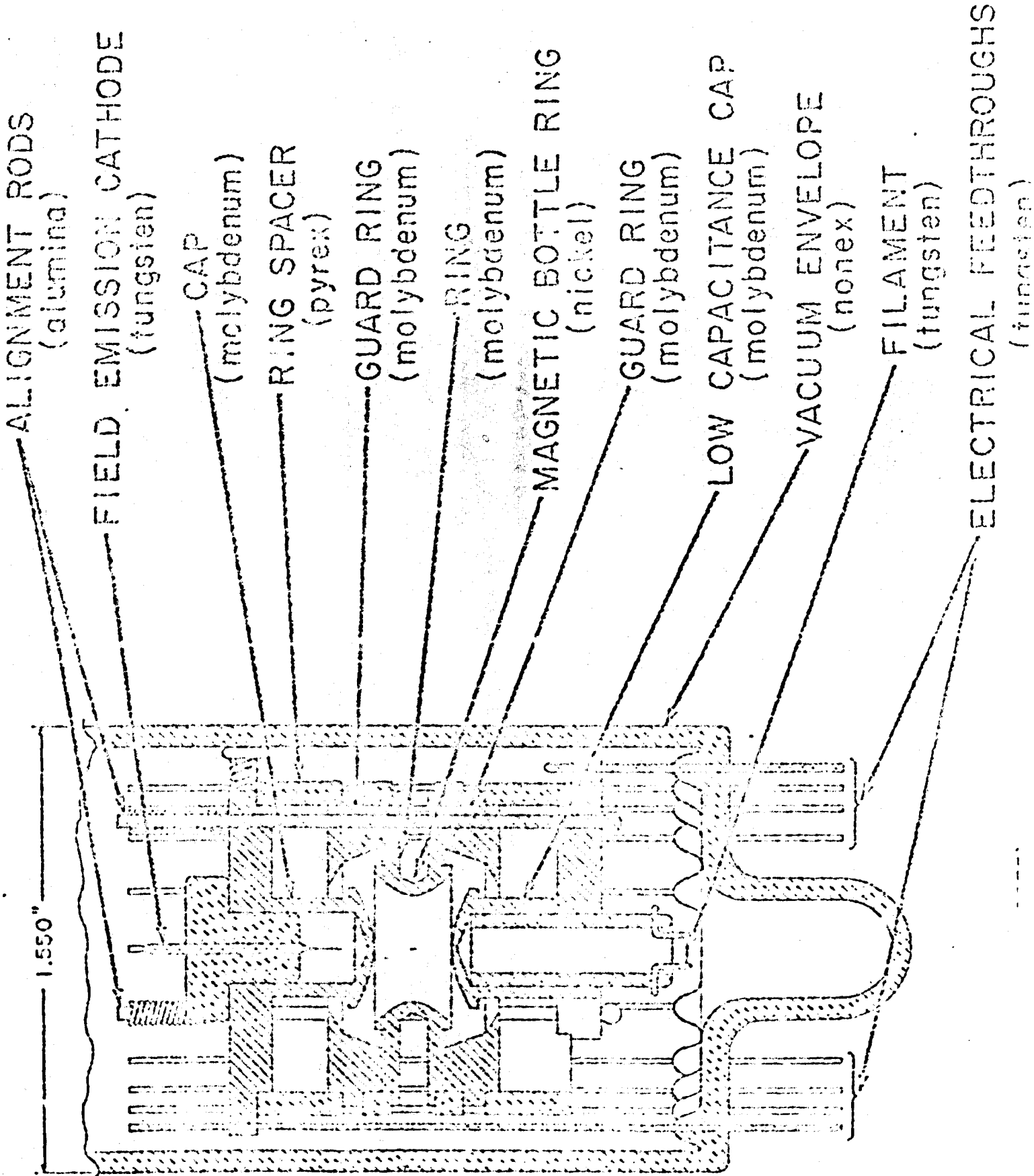

Best Available Copy

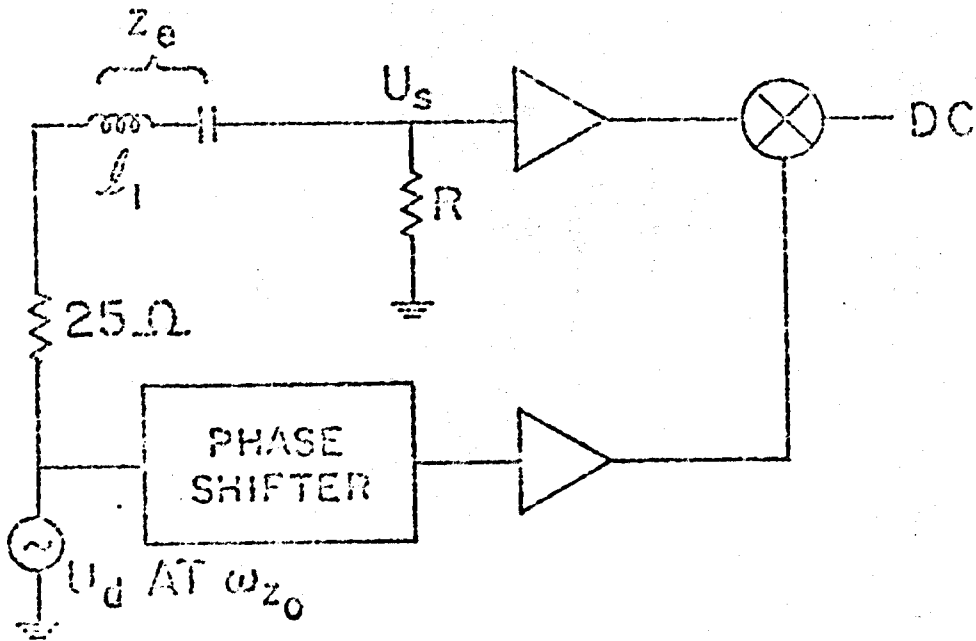

$$|z_e| = 2\Delta L_1 \gg R$$

$$\Delta = \left(\frac{d\omega}{dW_i} \right) W_i$$

← ANHARMONICITY
← ELECTRON AXIAL ENERGY

$$L_1 \approx 8000 \text{ Hy}$$

(WINELAND ET AL., 1973)

raised to a critical level of -2 mV the signal decreased roughly exponentially but in equal steps. We attribute the steps to loss of single electrons associated with an instability due to sign reversal of dv_z/dW_1 occurring at $K_1 \geq .2$ eV. At a lower u_d and $u_g = .2$ μ V the last plateau corresponding to a single electron has been observed continuously for days. As a first application the cyclotron resonance near 22 GHz was observed on this "monoelectron oscillator" (MEO). A trigger technique based on energy transfer from the excited cyclotron motion via gas collision to the axial motion parametrically driven at $2v_z$ was used. For the purpose of monitoring cyclotron and spin quantum numbers n, m of the MEO, Dehmelt & Ekstrom (1973b) have proposed to superimpose a magnetic bottle; $H_B = 100$ G deep, over the Penning trap fields. For our standard trap this would cause a shift $\delta v_z(n, m) = (2n + 1 + 2m)(3 \text{ Hz})$ of $v_z = 60$ MHz due to the contribution $(2n + 1 + 2m)\mu_0 H_B$, $\mu_0 H_B = .5$ μ eV, to the -6 eV deep trapping potential. Thereby it should be possible to literally watch the MEO jump from one n, m level to another, a MEO linewidth $\Delta v_z = 8$ Hz having been demonstrated recently (Wineland & al., 1975). A problem remaining is the coupling between the cyclotron motion and the "free space" radiation field. A solution, might be to enclose the trap in a small, tight high-Q microwave cavity and to choose ν_c thus as to decouple the MEO as much as possible from the few resonant modes the cavity can support. The current approach is to cool the MEO to 4°K . Thereby a dwell time in the $n = 0$ levels of ~ 1 sec may be realized at $\nu_c = 22$ GHz during which the shifts $\delta v_z(0, -\frac{1}{2}) = 0$ and $\delta v_z(0, +\frac{1}{2}) = 6$ Hz might be observed (Dehmelt et al. 1974). For $\nu_c = 200$ GHz the dwell times become so short that it becomes practical to measure the average shifts $\langle \delta v_z(n, \frac{1}{2}) \rangle$ which again differ by 6 Hz. Hereupon and on the very slow spin relaxation the detection of $g-2$ transitions induced when $n > 0$ may be based. The small shifts δv_z due to the relativistic mass changes $\delta m = (n + \frac{1}{2} + m) h\nu_c/c^2$, may become of interest for the detection of the $g-2$ resonance (Dehmelt et al., 1974). Rabi (1928) has solved the Dirac equation for an electron moving in a magnetic field. In accordance with this the spin state energy has to be regarded as kinetic as far as δm is concerned. For the MEO experiments quite modest $g-2$ transition rates suffice and it is of interest to look for possibly more convenient alternate ways to realize them. E. g. a static magnetic point dipole field is inhomogeneous enough for an electron carrying out its cyclotron motion at ν_c plus a forced axial motion at ν_d to see a usable magnetic rf field at the combination frequency $\nu_c + \nu_d$ (Dehmelt, 1969 p. 151). Even the relativistic magnetic field $B = E\nu/c = .1$ μ G seen by an 1 meV electron for $E = 1$ V/cm at ν_d may find application (Dehmelt & Ekstrom, 1973b). I wish to thank Dr. D. Wineland and Dr. R. Van Dyck for reading the manuscript, and Lyn Maddox for typing it.

CYCLOTRON RESONANCE AT ~22GHZ

1 PPM

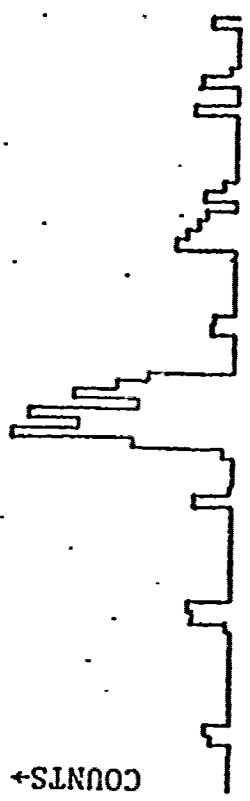

FREQUENCY

(DEHNELT, 1974)

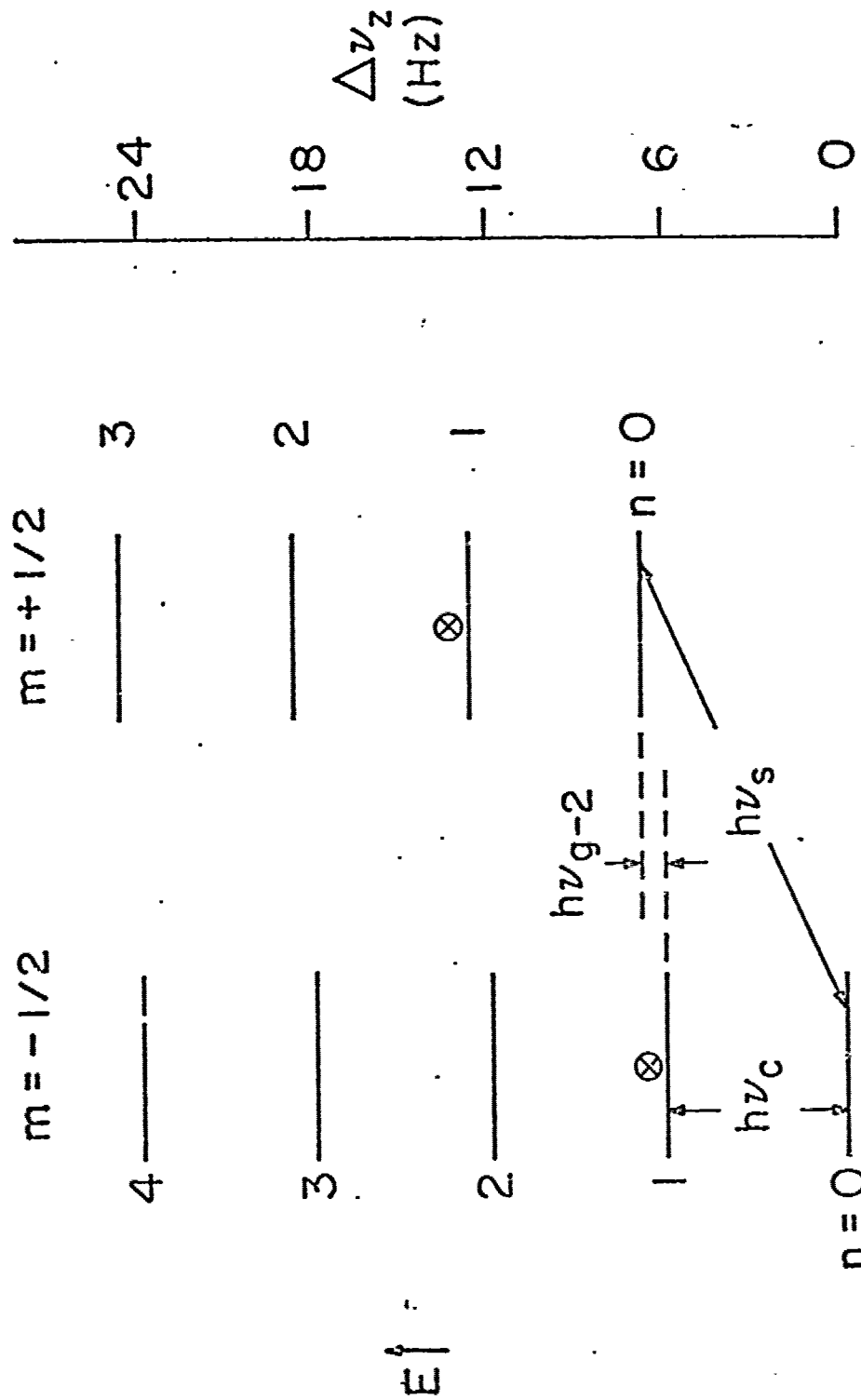

$H_0 = 60 \text{ KG}$ $T_0 = 8^\circ \text{ K}$ $\Delta \nu_z = (1 + 2n + gm) 3 \text{ Hz}$

(DEHMELT & EKSTROM, 1973)

- BLOCH, F. (1953). *Physica* 19, 821.
- BYRNE, J. (1963). *Can. J. Phys.* 41, 1571.
- CHURCH, D. A. & MOKRI, B. (1971). *Z. Physik* 244, 6.
- DEHMELT, H. (1961). Progress Report NSF-35955, May 1961, "Spin Resonance of Free Electrons".
- DEHMELT, H. (1962), *Bull. A.P.S.* 7, 470.
- DEHMELT, H. (1967 & 1969). *Adv. Atom. & Mol. Physics*, 3 & 5. (Academic Press).
- DEHMELT, H. & MAJOR, F. G. (1962). *Phys. Rev. Letters* 8, 213.
- DEHMELT, H. & WALLS, F. (1968). *Phys. Rev. Letters* 21, 127.
- DEHMELT, H. & EKSTROM, P. (1973a,b). *Bull. A.P.S.* 18, 408 & 786.
- DEHMELT, H. & WINELAND, D. (1973). *Bull. A.P.S.* 18, 786.
- DEHMELT, H. & EKSTROM, P., WINELAND, D. & VAN DYCK, R. (1974). *Bull. A.P.S.* 19, 643.
- FAIRDANK, W. H., WITTEBORN, F. C., MADEY, T. M. F. & LOCKHART, M. G. (1973). *Exp. Gravit.* 56, 310. (Academic Press).
- FARAGO, P. S. (1965). *Adv. Electronics & Electron Phys.* 21, 1.
- FISCHER, E. (1959). *Z. Physik* 156, 1.
- FORTSON, E. N., MAJOR, F. G., & DEHMELT, H. G. (1966). *Phys. Rev. Letters* 16, 221.
- FORTSON, N. E., GRAEFF, G., MAJOR, F. G., ROEDER, R. W. H., & WERTH, G. (1968). ICAP Abstracts of Contributed Papers, p. 9.
- FRANKEN, P. A., & LIEBES, S. JF. (1956). *Phys. Rev.* 104, 1197.
- GARDNER, J. H. (1951). *Phys. Rev.* 83, 996.
- GRAFF, G., KLEMPF, E. & WERTH, G. (1969). *Z. Physik* 222, 201.
- GRAFF, G. HUBER, K., KALINOWSKY, H. & WOLF, H., (1972). *Phys. Lett.* A41, 277.
- GRAFF, G., HUBER, K., & KALINOWSKY, H. (1975). Winter Meet. DPG.
- HUGHES, V. W. (1959). *Rec. Research Mol. Beams* (Academic Press).
- KIENOW, E. KLEMPF, E., LANGE, F., & NEUBECKER, K. (1974). *Phys. Lett.* A46, 441.
- KLEPPNER, D., GOLDENBERG, H. M., RAMSEY, N. F. (1962). *Phys. Rev.* 126, 603.
- KNIGHT, L. V. (1965). Ph.D. Thesis, Stanford Univ..
- LAND, S. E., & RAITH, W. (1974). *Phys. Rev.* A9, 1592.
- PENNING, F. M. (1937). *Physica* 4, 71.
- PIERCE, T. R. (1949). "Theory and Design of Electron Beams," Chap. 4, Van Nostrand, Princeton, New Jersey.
- RABI, I. I. (1928). *Z. Physik* 49, 507.
- RICH, A., & WESLEY, T. C. (1972). *Rev. Mod. Phys.* 44, 250.
- VAN DYCK, R. S., EKSTROM, P. A. & DEHMELT, H. G. (1975). *Bull. A.P.S.* 20, 492.
- WALLS, F. (1970). Thesis, Univ. of Washington.
- WALLS, F. & STEIN, T. (1973). *Phys. Rev. Lett.* 31, 975.
- WINELAND, D., EKSTROM, P., & DEHMELT, H. (1973). *Phys. Rev. Lett.* 31, 1279.
- WINELAND, D., & DEHMELT, H. (1975a). *Int. Journ. Mass Spectroscopy & Ion Phys.* 16, 338.
- WINELAND, D., & DEHMELT, H. (1975b). *Journal Appl. Phys.* 46, 919.
- WINELAND, D., VAN DYCK, R. & DEHMELT, H. (1975). *Bull. A.P.S.* 20.