

AD-A020 382

TRANSISTORIZED RF POWER AMPLIFIER AND DRIVER FOR
RECEIVER TRANSMITTERS RT-246/VRC AND RT-524/VRC

B. Williams

Harris Corporation

Prepared for:

Army Electronics Command

December 1975

DISTRIBUTED BY:

NTIS

National Technical Information Service
U. S. DEPARTMENT OF COMMERCE

044167

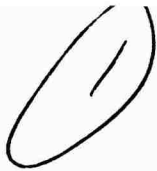

ADAU20382

Research and Development Technical Report

ECOM-75-0146-1

TRANSISTORIZED RF POWER AMPLIFIER AND DRIVER FOR RECEIVER TRANSMITTERS RT-246/VRC and RT-524/VRC

B. Williams
Harris Corporation
RF Communications Division
Rochester, New York 14610

December 1975

Quarterly Report for Period May 1975 to September 1975

REC'D
FEB 24 1976

Distribution Statement

~~This document is subject to special export controls and each transmittal to foreign governments or foreign nations may be made only with prior approval of Commander, US Army Electronics Command, Fort Monmouth, NJ, ATTN: AMSEL NJ R-6.~~

Prepared for
DCASD, ROCHESTER
US Courthouse, Federal Bldg
Rochester, New York 14614

Reproduced by
NATIONAL TECHNICAL
INFORMATION SERVICE
U.S. Department of Commerce
Springfield, VA. 22151

DISTRIBUTION STATEMENT A
Approved for public release;
Distribution unlimited

ECOM

US ARMY ELECTRONICS COMMAND FORT MONMOUTH, NEW JERSEY 07703

NOTICES

Disclaimers

The findings in this report are not to be construed as an official Department of the Army position, unless so designated by other authorized documents.

The citation of trade names and names of manufacturers in this report is not to be construed as official Government indorsement or approval of commercial products or services referenced herein.

Disposition

Destroy this report when it is no longer needed. Do not return it to the originator.

SECURITY CLASSIFICATION OF THIS PAGE (When Data Entered)

REPORT DOCUMENTATION PAGE		READ INSTRUCTIONS BEFORE COMPLETING FORM
1. REPORT NUMBER ECOM-75-0146-1 ✓	2. GOVT ACCESSION NO.	3. RECIPIENT'S CATALOG NUMBER
4. TITLE (and Subtitle) TRANSISTORIZED RF POWER AMPLIFIER AND DRIVER FOR RECEIVER TRANSMITTERS RT-246/VRC AND RT-524/VRC ✓	5. TYPE OF REPORT & PERIOD COVERED QUARTERLY MAY 1975 to SEP 1975	
	6. PERFORMING ORG. REPORT NUMBER	
7. AUTHOR(s) B. Williams	8. CONTRACT OR GRANT NUMBER(s) DAAB07-75-C-0146 <i>NEW</i>	
9. PERFORMING ORGANIZATION NAME AND ADDRESS HARRIS CORP., RF COMMUNICATIONS DIV. ✓ 1680 UNIVERSITY AVENUE ROCHESTER, NEW YORK 14610	10. PROGRAM ELEMENT, PROJECT, TASK AREA & WORK UNIT NUMBERS CLIN 0002	
11. CONTROLLING OFFICE NAME AND ADDRESS DCASD, ROCHESTER S3304A54002PC US COURTHOUSE, FEDERAL BLDG 100 STATE ST, ROCHESTER, N.Y. 14614	12. REPORT DATE DECEMBER 1975	
	13. NUMBER OF PAGES 53	
14. MONITORING AGENCY NAME & ADDRESS (if different from Controlling Office) US ARMY ELECTRONICS COMMAND FORT MONMOUTH, N.J. 07703 AMSEL-NL-R-6	15. SECURITY CLASS. (of this report) UNCLASSIFIED	
	15a. DECLASSIFICATION/DOWNGRADING SCHEDULE	
16. DISTRIBUTION STATEMENT (of this Report) This document is subject to special export controls and may be transmitted to foreign governments or foreign citizens only made only with prior approval of Commander, US Army Electronics Command, Fort Monmouth, N.J. Attn: AMSEL NL R-6		
17. DISTRIBUTION STATEMENT (of the abstract entered in Block 20, if different from Report)		
18. SUPPLEMENTARY NOTES		
19. KEY WORDS (Continue on reverse side if necessary and identify by block number) Power Amplifier, VHF, Solid State, VRC-12		
20. ABSTRACT (Continue on reverse side if necessary and identify by block number) This first quarterly report describes development work to date on the transistorized RF Power Amplifier and Tuner/Driver Assembly for the Receiver Transmitter RT-524 and RT-246. The calendar period covered for the material is 23 May to 15 Sep 1975. During this reporting period, a breadboard power amplifier and tuner/driver were constructed and bench tested. Initial tests		

indicated that adequate power could be obtained from a single power amplifier transistor. The A6100 tuner assembly was successfully incorporated in the driver amplifier design.

Data is presented on the output power, driver power, impedance measurements, output selectivity of the PA, regulator characteristics and power control characteristics.

*letter on file
AT*

TABLE OF CONTENTS

<u>Section</u>	<u>Title</u>	<u>Page</u>
	LIST OF ILLUSTRATIONS	ii
1.0	INTRODUCTION	1
2.0	REQUIREMENTS.	2
3.0	DESIGN ACCOMPLISHMENTS.	4
3.1	Tuner/Driver Assembly	4
3.2	Power Amplifier	12
3.3	Power and Control Circuits.	29
3.4	Mechanical Packaging.	33
4.0	CONCLUSIONS	34
	APPENDIX.	35

LIST OF ILLUSTRATIONS

<u>Figure No.</u>	<u>Title</u>	<u>Page</u>
3.1-1	Block Diagram of New Circuit Arrangement.....	4
3.1-2	Modification to A6100.....	7
3.1-3	Solid State Amplifier Tuner/Driver Assembly.....	8
3.1-4	Test Data Engineering Model Tuner/Driver Assembly	9
3.1-5	Impedance Plot of Broadband Output Transformer...	11
3.2-1	Amplifier Block Diagram.....	13
3.2-2	Output Matching - 12.25:1 Transformer.....	14
3.2-3	Input Impedance - J01006.....	15
3.2-4	Input Matching PA.....	17
3.2-5	Input Matching - PA & 3 dB Pad.....	18
3.2-6	Power Amplifier Schematic.....	19
3.2-7	Power Amplifier Data.....	21
3.2-8	Output Tank Matching.....	22
3.2-9	Low Band Output Tank Selectivity.....	23
3.2-10	High Band Output Tank Selectivity.....	24
3.2-11	Tuner/Driver Assembly and Power Amplifier Block Diagram.....	25
3.2-12	Reverse Intermodulation Test Setup.....	26
3.2-13	Engineering Model Data.....	28
3.3-1	P.A. Regulator.....	29
3.3-2	Regulator Test Data.....	30
3.3-3	Power Control Circuit (ALC).....	31
3.3-4	Variation of Power.....	32

1.0 INTRODUCTION

The purpose of this contract is to develop a design modification to the transmitter/power supply for the Receiver-Transmitter Radio, RT-246/VRC and RT-524/VRC. It is the objective of this modification to:

- 1) Increase Reliability
- 2) Minimize broadband noise and harmonic emissions
- 3) Eliminate the high-voltage power supply and vacuum tube in the Power Amplifier and Driver Assembly.
- 4) Design a low cost conversion kit suitable for retrofit by low-skilled personnel.

This first quarterly report will discuss the design and development results achieved during the first 90 days of this contract. This includes a discussion of the Tuner/Driver Assembly, power amplifier, power supply and automatic level control.

2.0 REQUIREMENTS

The technical approach is directed toward meeting Specification EL-CP0108-0001A, SCN001 and SCN002 in accordance with the work statement in section F.2 of the contract DAAB07-75-C-0146. Maximum utilization of existing parts is desirable to minimize conversion costs. These include:

- a) Power Amplifier Heat Exchanger
- b) Fan
- c) Fan power supply
- d) Power Amplifier output tank circuit and tuning mechanism
- e) Transmitter driver assembly tuned circuits
- f) Low band low pass antenna filter (FL 401)
- g) All transmitter circuitry up to and including the buffer amplifier assembly

The transmitter output tank circuit and driver assembly tuned circuits are retained to achieve the required selectivity necessary to limit the transmitter noise to -140 dB below the carrier. Retention of these three tuned circuits is based on worst case noise measurements at ECOM of -95 dBm in a 30 kHz bandwidth at the output of the existing RT-524/VRC Transmitter Buffer.

The chart below shows the gain distribution at the worst case frequency of 76 MHz and the attenuation of noise ± 10 MHz away necessary to achieve the noise attenuation requirement.

	<u>Noise Attenuation ± 10 MHz</u>	<u>Gain @ 76 MHz</u>
1st Tunable Filter	-12 dB	
Cascode Amplifier		10 dB
2nd Tunable Filter	-12 dB	
Driver Amplifier		10 dB
Power Amplifier		10 dB
3rd Tunable Filter	<u>-10 dB</u>	
	Total	<u>+30 dB</u>
	Net Attenuation	
	- 4 dB	
Input noise (max.)	-95 dB in 30 kHz BW	
	Attenuation	
	<u>- 4 dB</u>	
Output Noise (max.)	-99 dBm or	-144.5 dB
		± 35 W

It is also essential that in meeting the new selectivity requirements, that tracking, with the existing mechanical frequency controls, be maintained.

The requirement to package the modification using the existing parts further imposes restrictions on size, module layout and heat dissipation. Also to minimize rework and the associated costs, mounting holes in existing assemblies such as the heat exchanger will be used to the maximum extent practical.

3.0 DESIGN ACCOMPLISHMENTS

3.1 Tuner/Driver Assembly

The Tuner Driver Assembly will utilize the same inductuner as presently used in the Transmitter Driver Assembly A6100. The new solid state amplifier will plug into the tube socket and mount to the heat sink partition where the tube shield presently clips. A block diagram of the new circuit arrangement is shown in Figure 3.1-1 below.

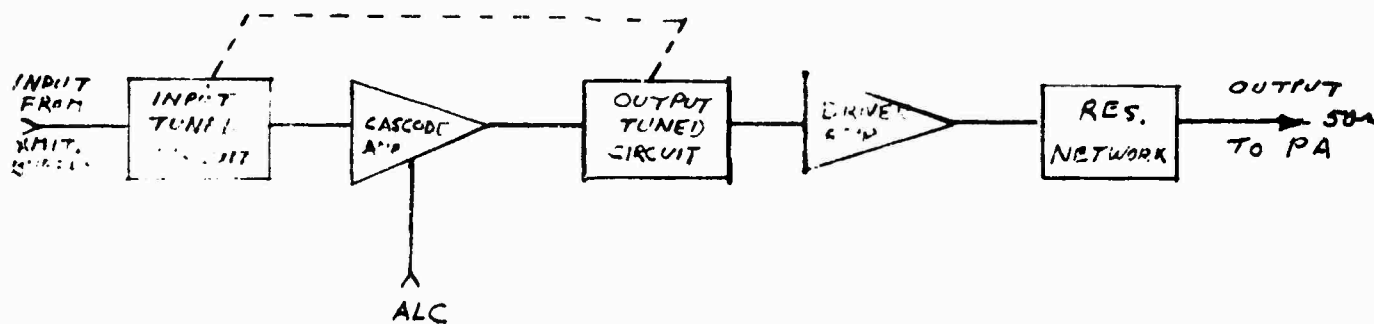

Figure 3.1-1

It is seen from the block diagram, that the driver amplifier is placed outside the tuned circuits. This was done to minimize the potential for oscillation by restricting the gain between pins 2 and 7 of the tube socket. In addition the RF current through the wiper contact of the second tuned circuit is held to a minimum, preventing any deterioration.

The major considerations in designing the solid state amplifier for the tuner are:

- 1) Maintain tracking
- 2) Achieve at least 24 dB of selectivity at ± 10 MHz from f_c
- 3) Stability over the entire frequency and ALC range

4) Relatively low noise figure

A cascode-coupled amplifier offers stability and high gain with a low noise figure, simplicity in coupling and the opportunity to establish gain control.

FET's were first investigated for use in this circuit. Their higher input resistance and low noise figure is attractive in this application, however at the power levels required (1 watt), the availability of transistors is quite limited. Higher input capacitance goes along with higher power which makes tracking more difficult without loss of gain. It is believed that FET's would perform satisfactorily in this application, however the availability of bipolar devices and extensive information on their operating parameters led to the early selection of these devices.

The input of the cascode amplifier is connected through a 5 pF capacitor to pin 2 of the tube socket. The capacitor in conjunction with the base impedance of the transistor closely approximates the input capacitance of the original vacuum tube, V6101, thereby maintaining tracking. A diode is also connected from base to ground, to maintain a zero bias without additional loading. The collector is direct coupled to the emitter of the second stage. The base receives its bias through a divider network while the collector is connected through a choke to B+. The collector is also connected to the second tuned circuit, pin 7, through a capacitive matching network. Capacitive loading at pin 7 is also provided to match the tube output capacitance in order to maintain tracking.

Since the cascode amplifier operates at about a 1 watt

level, stabilization networks are necessary to prevent subharmonics and spurious. These take the form of high frequency loading and resistive isolation from the reactive elements of the output tuned circuit.

To maintain the output tuned circuit Q and thereby retain the required selectivity, a broadband matching transformer was used. This transformer with a 15.5 to 1 turns ratio, provides about a 1000 ohm load to the output tuned circuit while matching the 4 ohm input impedance of the driver stage. The transformer was made from a K12-20 pot core with an inductive reactance matching L6105 which it replaced.

The driver stage provides an additional 10 dB of gain, bringing the output to a level of 5 to 6 watts. The output is matched to 50 ohms through a broadband transformer constructed on a 1Z2 balun. With a 50 ohm output impedance, measurements can readily be made using standard test equipment. A 50 ohm 2-3 dB isolation network is also required in the output to prevent interaction and spurious between the power amplifier and the Tuner/Driver assembly.

A schematic of the Tuner/Driver Assembly is included as Figures 3.1-2 and 3.1-3. Figure 3.1-2 shows the modification to the A6100 Tuner and Figure 3.1-3 shows the new plug-in circuit. Test data taken on the Engineering Model Tuner/Driver Assembly is shown in Figure 3.1-4. The power output level shown is after the 3 dB resistor network and into a 50 ohm load. It will be seen in the next section that the RF input power requirements for the lower frequencies are substantially less than the 7 watt capability of the driver. This will allow the driver to operate at a lower

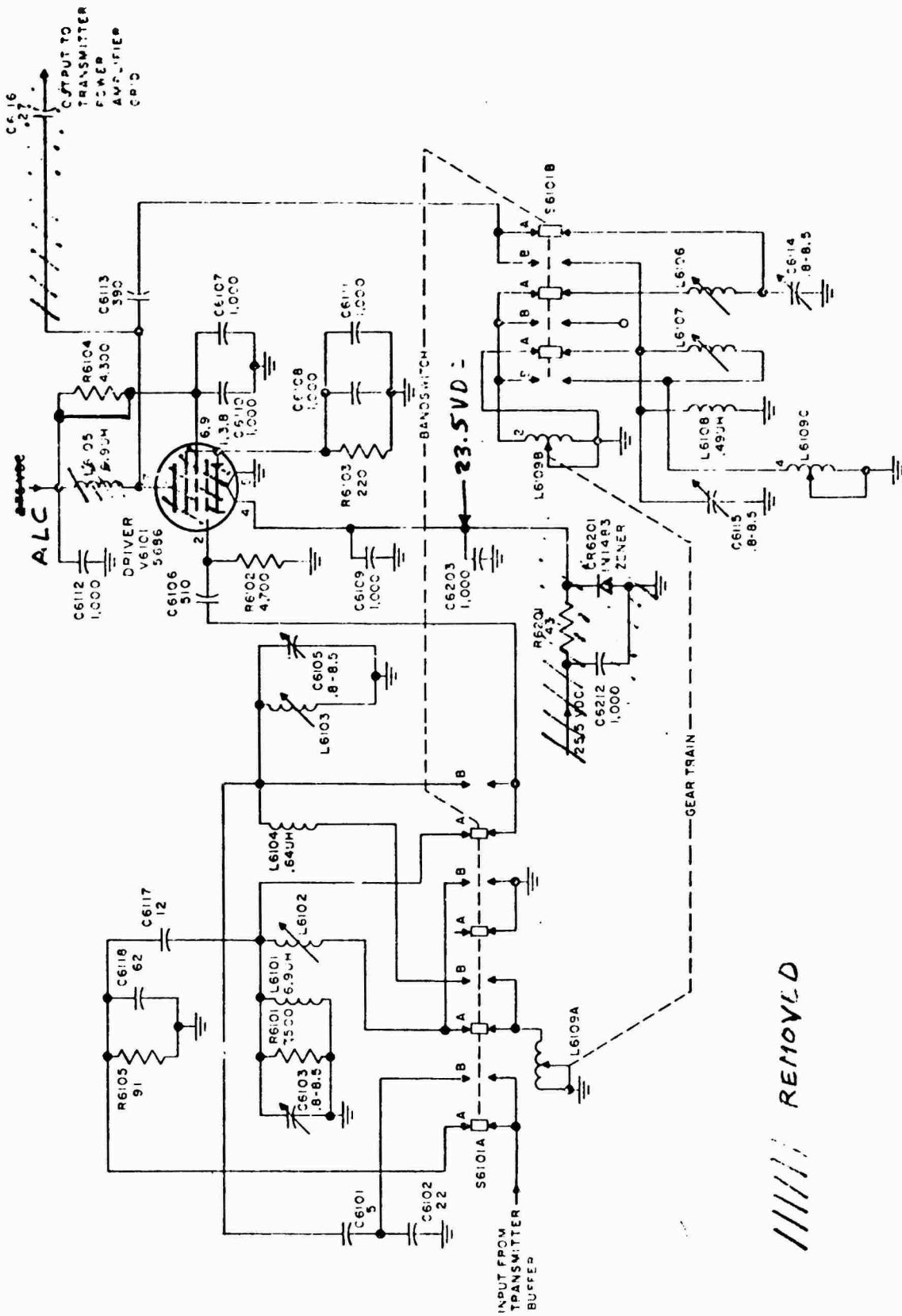

TVS820-399-35-6

FIGURE 3.1-2
MODIFICATION TO A6100

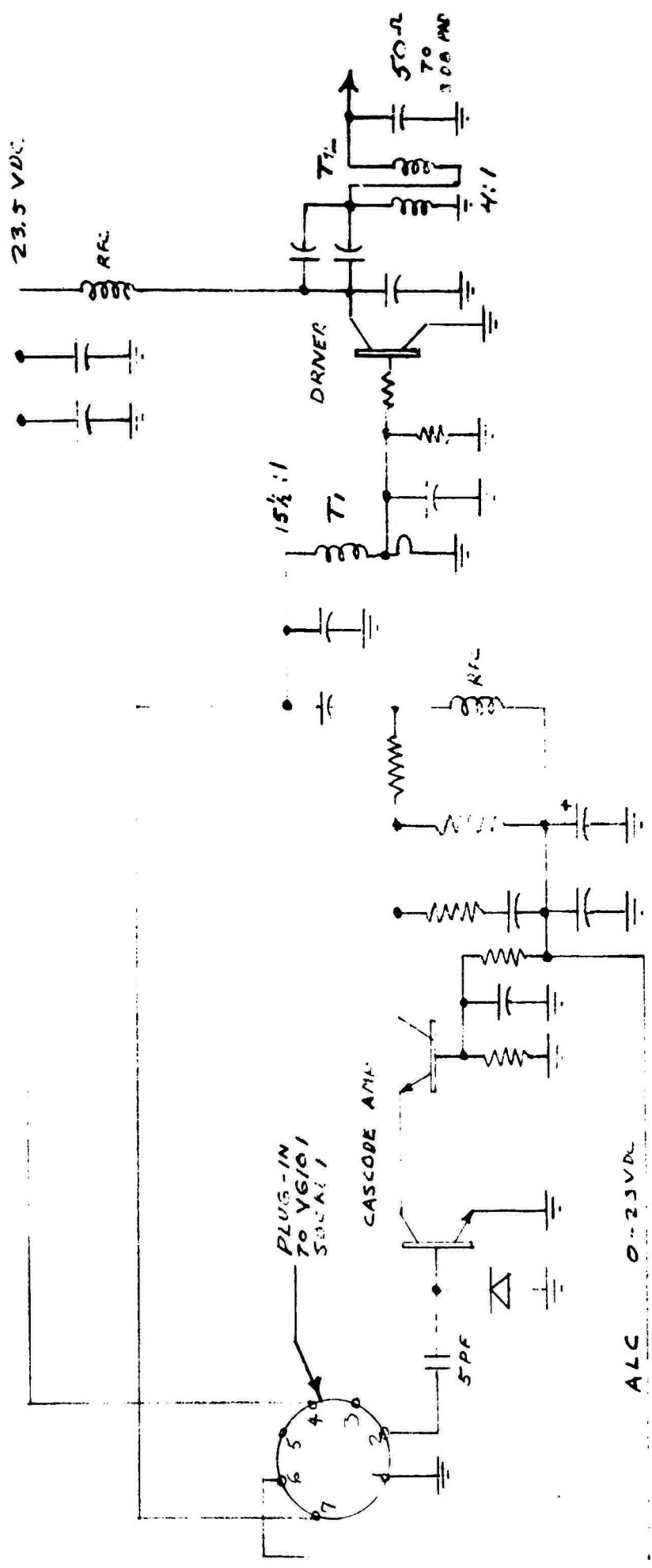

FIGURE 3.1-3
 SOLID STATE AMPLIFIER
 TUNNER / DRIVER ASSEMBLY

Tuner/Driver Assembly

<u>Freq</u> <u>MHz</u>	<u>P_{out}</u> <u>W</u>	<u>I</u> <u>A</u>	<u>B+</u> <u>V</u>	<u>P_{in}</u> <u>MW</u>	<u>Input Z</u> <u>Ohms</u>
30	7	0.8	23	50	35 + J8
35	7	1.8	23	50	34 + J16
40	7	1.8	23	50	40 + J17
45	7	1.4	23	50	42 + J26
50	7	1.2	23	50	48 + J36
55	7	1.4	23	50	25 - J2
60	7	1.2	23	50	26 - J3
65	7	1.1	23	50	22 + J5
70	7	1.0	23	50	25 + J10
76	7	1.0	23	50	36 + J22

Figure 3.1-4

current than the levels indicated in the data. An impedance plot of the broadband output transformer is included as Figure 3.1-5. This plot shows only a slight variation from 50 ohms at the low end.

TITLE

DATE

4:1 DRIVEN TRANSFORMER T₂ IMPEDANCE COORDINATES—50-OHM CHARACTERISTIC IMPEDANCE

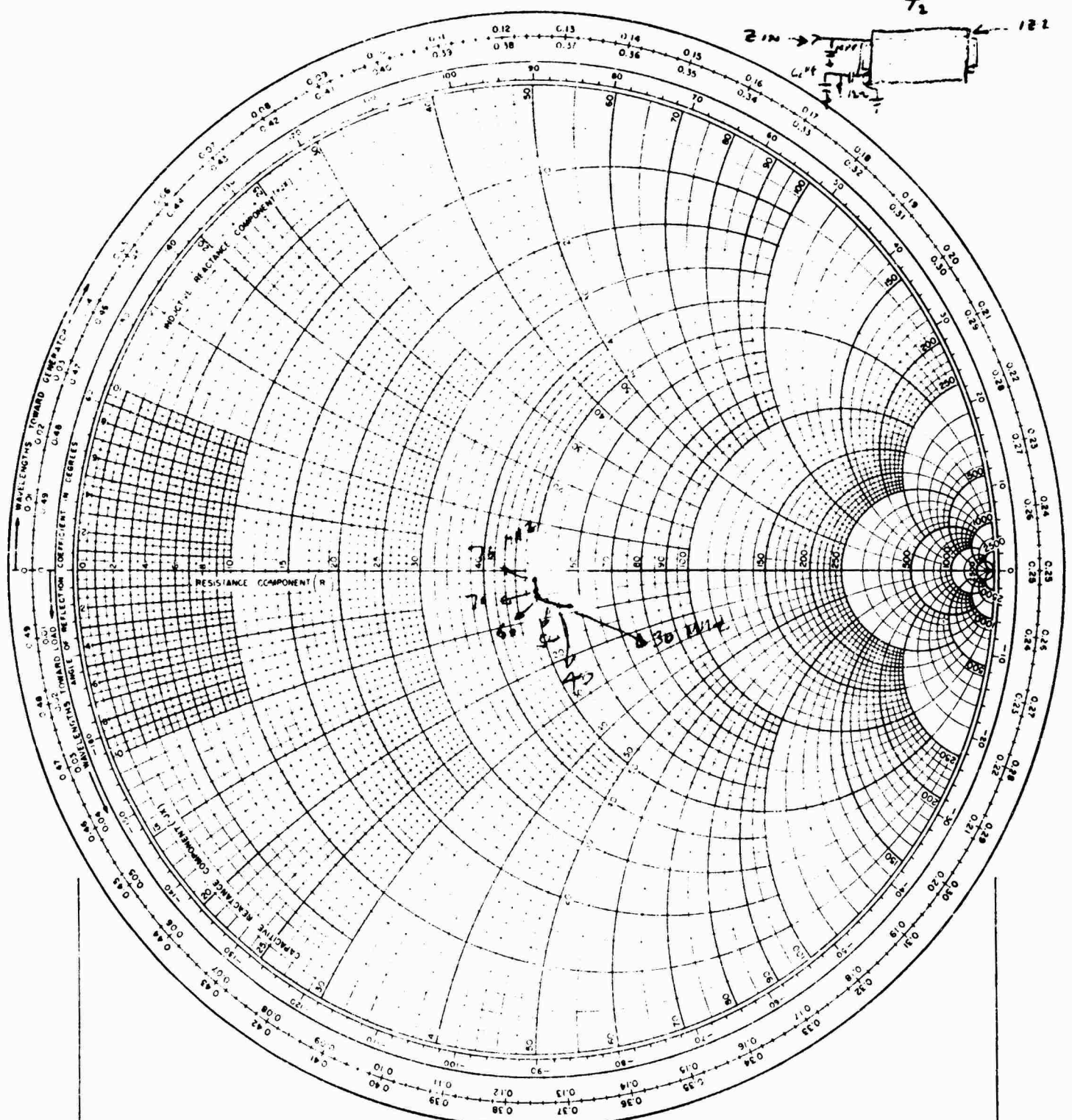
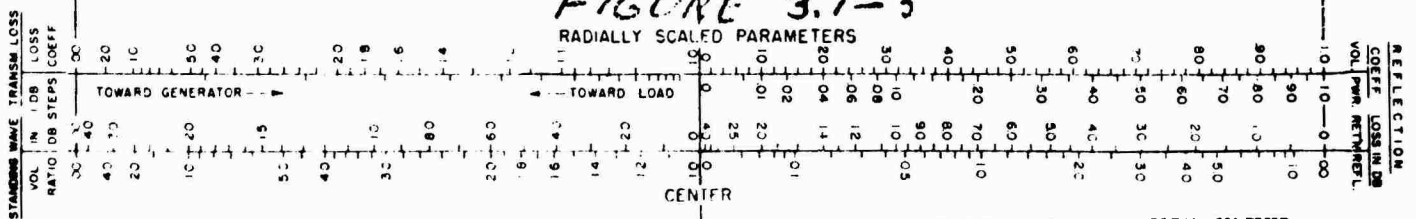

FIGURE 3.1-5
RADIALLY SCALED PARAMETERS



3.2 Power Amplifier

The solid state power amplifier is required to amplify the 5-6 watt drive level to 60 watts of RF collector power providing a gain of 10 to 11 dB. This must be accomplished in the minimum space available where the vacuum tube (V6201) was located and utilize the existing heat sink to its maximum advantage.

The initial approach was to use a push-pull amplifier similar to the one delivered to ECOM under contract DAAB07-72-B-0153. With the additional loss of the tuned tank circuit, about 0.7 dB, and the very limited space available, this design was considered not practical. Newer higher power transistors could overcome the marginal power problem but with no decrease in space requirements. More complex heat sink configurations were evaluated including the proposed \perp and the U shapes, but the added complexity was not considered cost effective.

The simplest and most direct approach is a single transistor mounted to a flat plate attached directly to the heat sink. This transistor would operate single ended class C. This approach is dependent on: the availability of a transistor with sufficient power capability after derating, at least 11 dB gain at 76 MHz and reliable operation under high VSWR conditions. Such transistors are available from both CTC and TRW.

The output of the single ended stage must be coupled to the final tank circuit. The high impedance output of the vacuum tube allowed coupling directly across the tank. With a load line of only 4 ohms for the transistor power amplifier, it is not only necessary to tap down on the tank circuit but to further transform the practical tap impedance (50 ohms) to the required 4 ohms. A

broadband transformer was designed to accomplish this. The power amplifier then becomes a single ended broadband amplifier with at least 11 dB gain from 30 to 76 MHz. Such an amplifier has been successfully built and bench tested. A block diagram is shown in Figure 3.2-1 below.

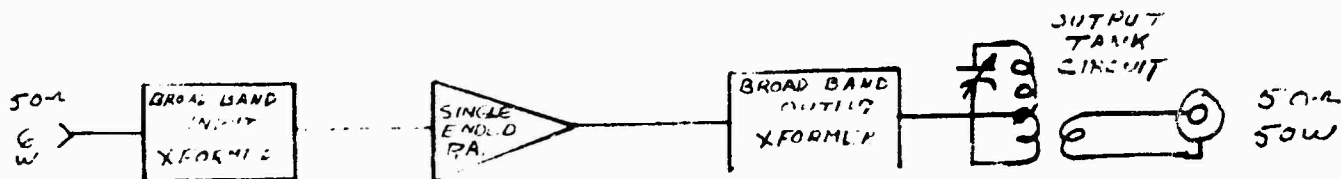

Figure 3.2-1

The output impedance of the broadband power amplifier was established at 50 ohms for convenience of measurements and to allow the reasonable placement of a tap on the output tank circuit. With the collector operating at 23.5 V, derived from the regulator, the load line for a 60 watt single ended class C stage, was determined to be 4 ohms. The transformer impedance ratio of 12.25:1 was obtained from a low loss broadband design autotransformer with a turns ratio of 7:2. An impedance plot for this transformer connected to the circuit was measured on an HP 8407 Network Analyzer. The results are shown in Figure 3.2-2. It is seen from this plot that only a minor variation from 50 ohms occurs at the lower frequencies.

The input match to the transistor must transform 50 ohms to the base impedance of the transistor. The J01006 transistor used in the engineering model has a measured base impedance of from 1.5 ohms at 30 MHz to 0.8 ohms at 76 MHz. An impedance plot with frequency is shown in Figure 3.2-3. Matching this extremely low

WITH THREE 1000 PF CAPS
 IMPEDANCE COORDINATES - 50-OHM CHARACTERISTIC IMPEDANCE

FIGURE 3.2-2

FIGURE 3.2-2

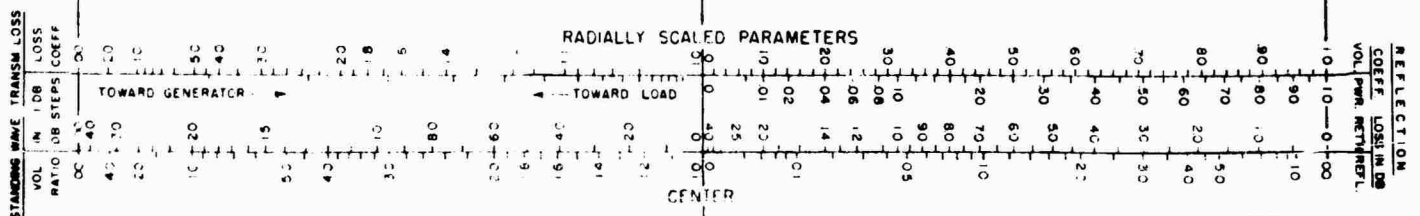
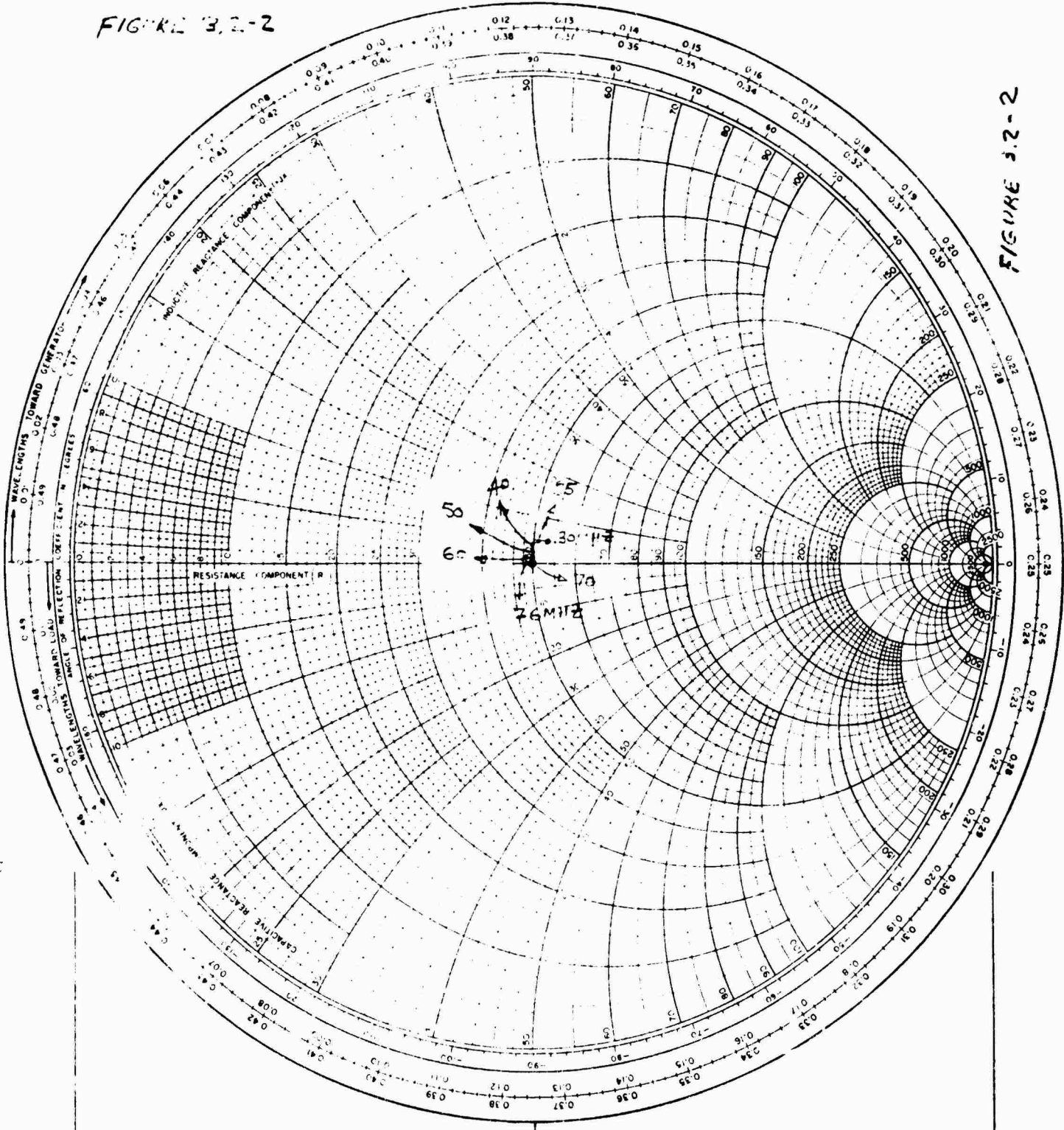

TITLE

INPUT IMPEDANCE - J01006

DATE

9/2/75

IMPEDANCE COORDINATES - 50-OHM CHARACTERISTIC IMPEDANCE

FIG. 3.2-3

FIG. 3.2-3

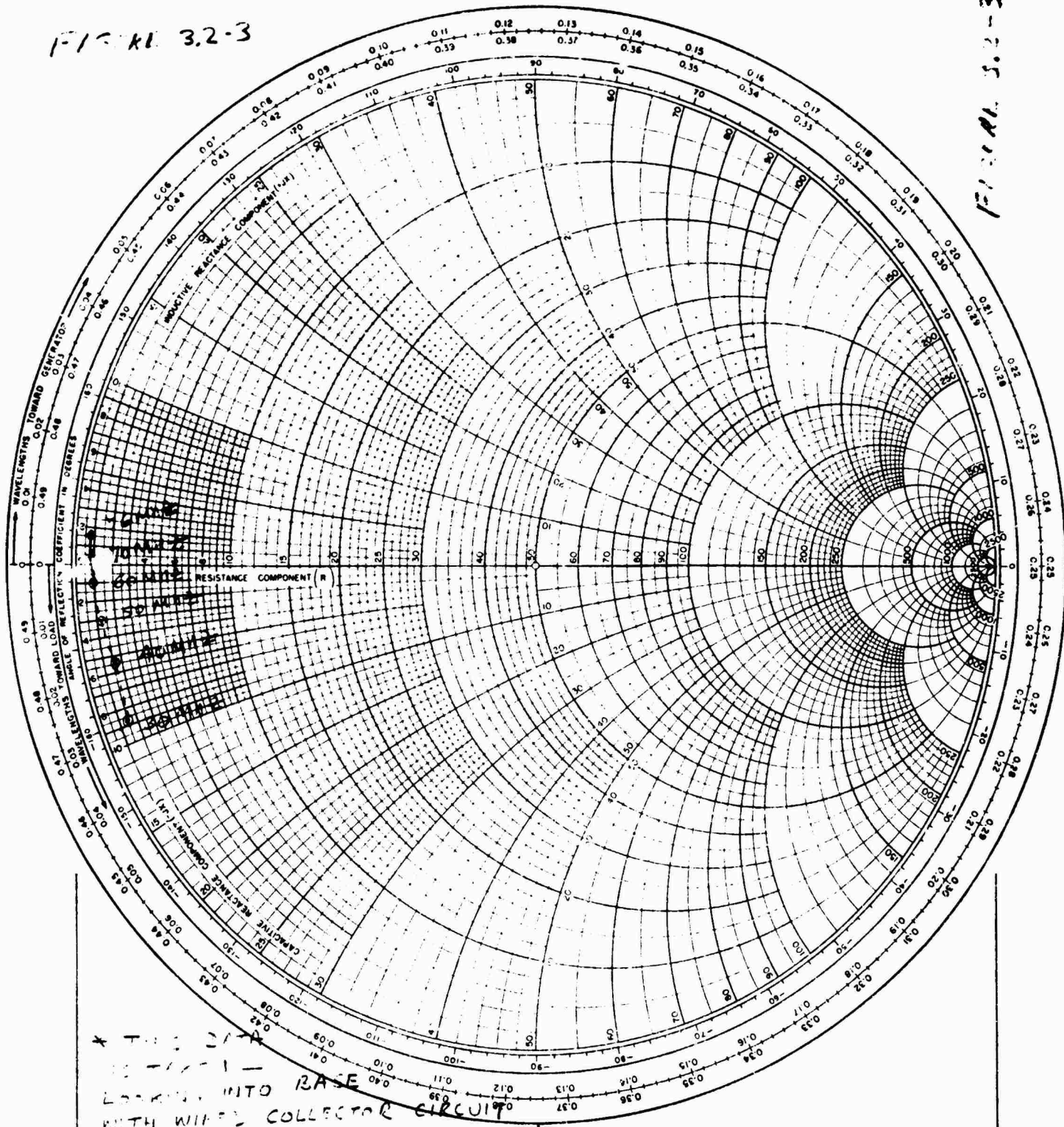

X
 LOOKING INTO BASE
 WITH WINDS COLLECTOR CIRCUIT
 R+ OFF

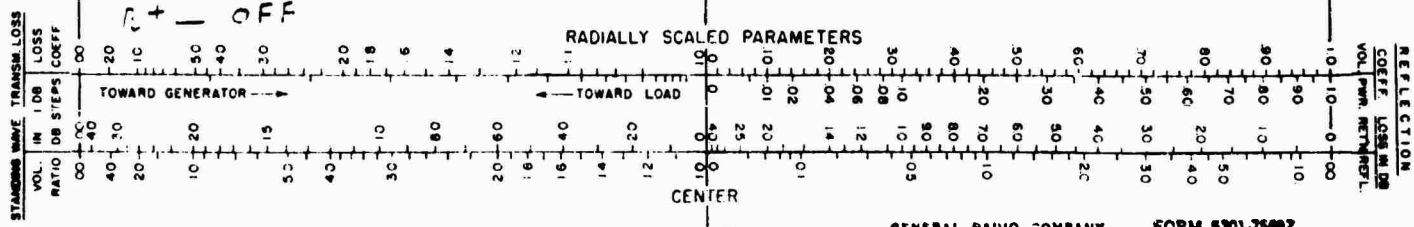

impedance across the band is difficult since any stray reactance when compared to 1 ohm is significant. An impedance plot looking into the 50 ohm input is shown in Figure 3.2-4. It is seen from this plot, that a variation of greater than 2:1 occurs in the low band. This wide variation in input reactance causes the driver to become unstable in the vicinity of 45 MHz, when connected to the power amplifier. To swamp out this effect a resistive divider network is placed in the output of the driver. Figure 3.2-5 shows the input impedance looking through the resistor divider network into the power amplifier. Note that at all frequencies the impedance presented to the driver is well within the 2:1 circle. Further effort to improve the input transformer would result in a better input match and increase the overall efficiency. Continued effort will be expended in this area.

A schematic of the power amplifier is shown in Figure 3.2-6. The resistor, capacitor network placed in series with the base reduces the tendency to spur when reactive loads are connected to the output. In effect this network reduces the low frequency gain of the transistor. Other techniques were evaluated such as shunt loading but found to be less effective. The collector to base series resonant feedback network is designed to neutralize the collector to base capacitance at mid-band. This reduces the effect of the output network, including the output transformer, on the input impedance. Since the output transformer has its reactance tuned out in mid-band, this isolation prevents any tendency to spur at these frequencies.

The power amplifier is designed to produce 60 watts of RF power over the 30 to 76 MHz band when connected to a 50 ohm

(WITH NO PAD)
 IMPEDANCE COORDINATES—50-OHM CHARACTERISTIC IMPEDANCE

FIGURE 3-4

FIGURE 3.2-4

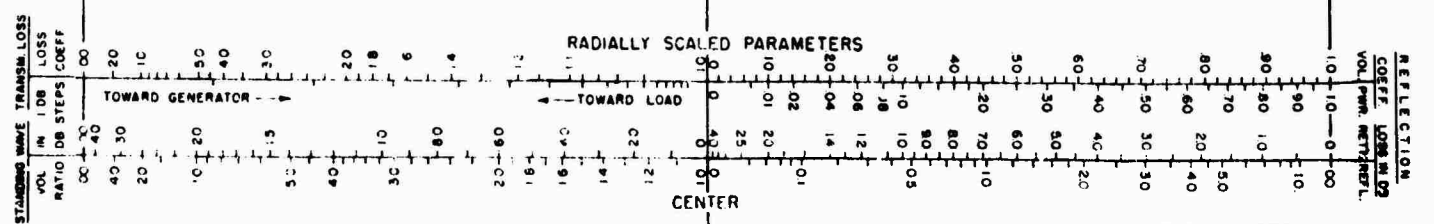
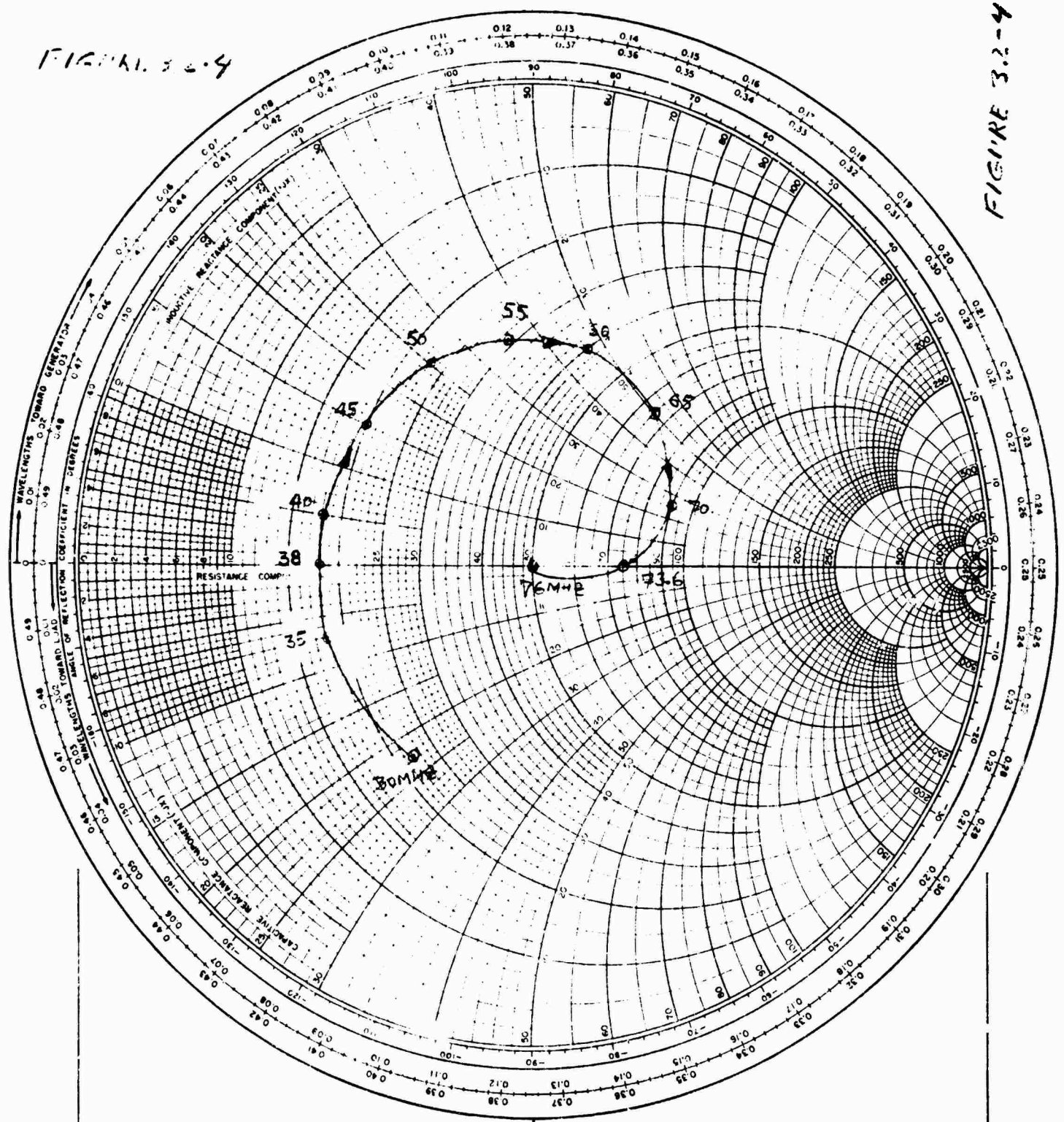

42.1VDC

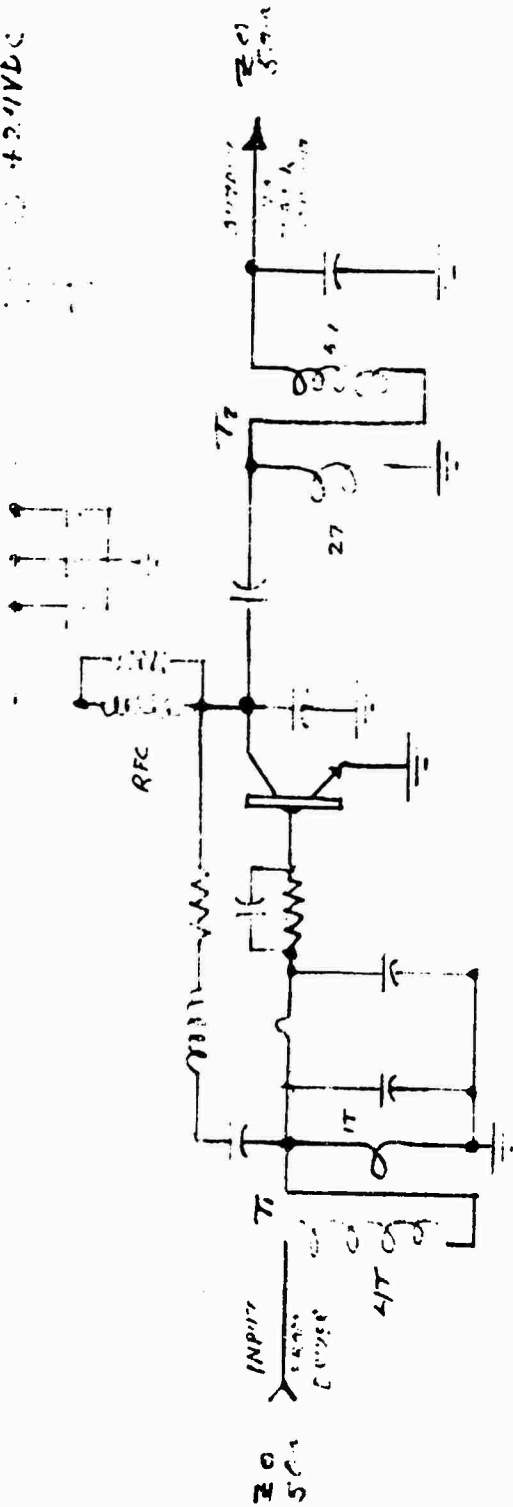

POWER AMPLIFIER
SCHEMATIC
1.1.1.1.1.

resistive load. Figure 3.2-7 shows the data taken on the engineering model. From this data, it is seen that the collector efficiency is running over 60 percent for most of the band. The maximum dissipation for the TRW-J01006 or the similar CTC 2N6369 is 220 watts at 25°C. Simulated temperature tests indicate a maximum case temperature of less than 100°C. With a thermal resistance for this device of 0.8°C/watt, a margin of over 100 watts dissipation exists. This is more than adequate even under infinite VSWR conditions so long as the current is limited to 5 amps. A current limiting regulator is being designed for this application.

To connect the broadband power amplifier to the output tank circuit, it is necessary to locate the 50 ohm tap point on the coil. This was accomplished by using the network analyzer connected to a movable tap. The output loop was terminated in 50 ohms and adjusted for minimum loss. The optimum point was found to be slightly more than 3/4 turn from ground and with the loop tightly coupled. Insertion loss, return loss and VSWR were measured for both High Band and Low Band Coils. The data recorded is shown in Figure 3.2-8. Selectivity curves were then recorded at various frequencies across the band. Figure 3.2-9 and Figure 3.2-10 show the family of curves for the Low Band and High Band, respectively.

It is seen from the two selectivity curves that low frequency feedthrough is occurring below f_c . At very low frequencies the loading from the tap to ground substantially reduces the available signal. Low frequency feedthrough can be reduced by decreasing the coupling between the pickup loop and the tank circuit. To maintain the 50 ohm impedance at the tap, the distances to ground

Frequency MHz	Output Power μ	Input Power μ	I A	Efficiency %	Gain dB	B+ = 24 VDC
30	60	2.3	4.2	59.5	14	
35	60	2.4	3.9	64	13.9	
40	60	2.2	3.8	65.8	14.4	
45	60	3.1	4.3	58	12.9	
50	60	3.8	4.5	55.6	12	
55	60	3.9	4.1	61	11.9	
60	60	4.3	3.7	67.6	11.4	
65	60	5.0	3.7	67.6	10.8	
70	60	5.6	3.7	67.6	10.3	
76	60	5.8	3.7	67.6	10.1	

50 μ Resistive
Load

FIGURE 3.2-7
POWER AMPLIFIER DATA

<u>Frequency</u> <u>MHZ</u>	<u>Low Band</u> <u>Insertion</u> <u>Loss dB</u>	<u>Return</u> <u>Loss dB</u>	<u>Frequency</u> <u>MHZ</u>	<u>High Band</u> <u>Insertion</u> <u>Loss dB</u>	<u>Return</u> <u>Loss dB</u>
30	0.7	>29 (+J)	53	0.75	>33 (+J)
32	0.7	>30 (+J)	55	0.7	>33 (+J)
35	0.7	>33 (+J)	58	0.7	>33 (+J)
37	0.65	>33 (+J)	60	0.7	>33 (-J)
40	0.7	>33 (+J)	63	0.7	>33 (-J)
42	0.7	>33 (+J)	65	0.75	>33 (-J)
45	0.6	>33 Real	68	0.75	>33 (-J)
47	0.6	>33 (-J)	70	0.75	>33 (-J)
50	0.6	>33 (-J)	72	0.75	>33 (-J)

22

VSWR 1.045:1 to 1.075:1

VSWR 1.045:1

FIGURE 3.2-8
OUTPUT TANK MATCHING

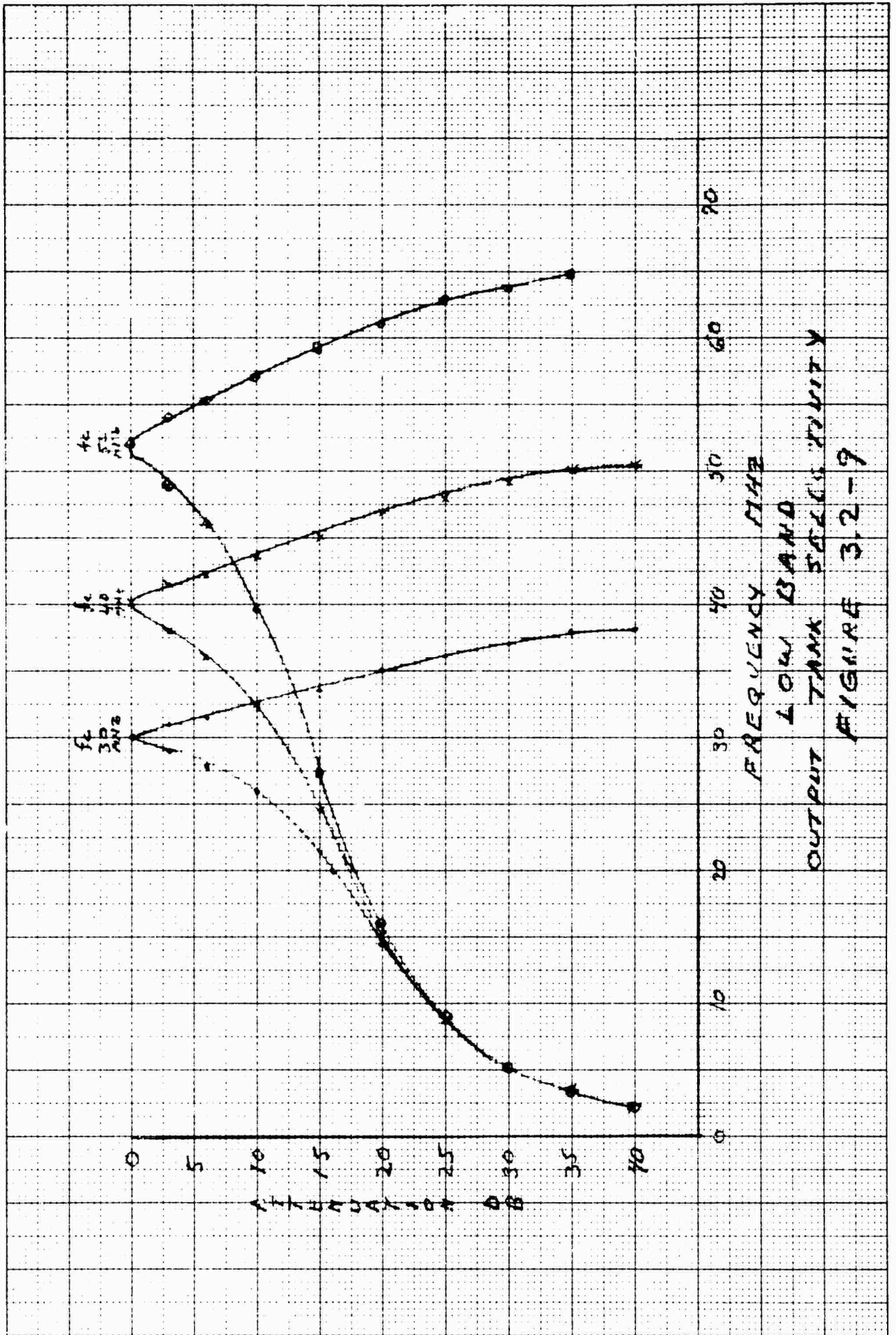

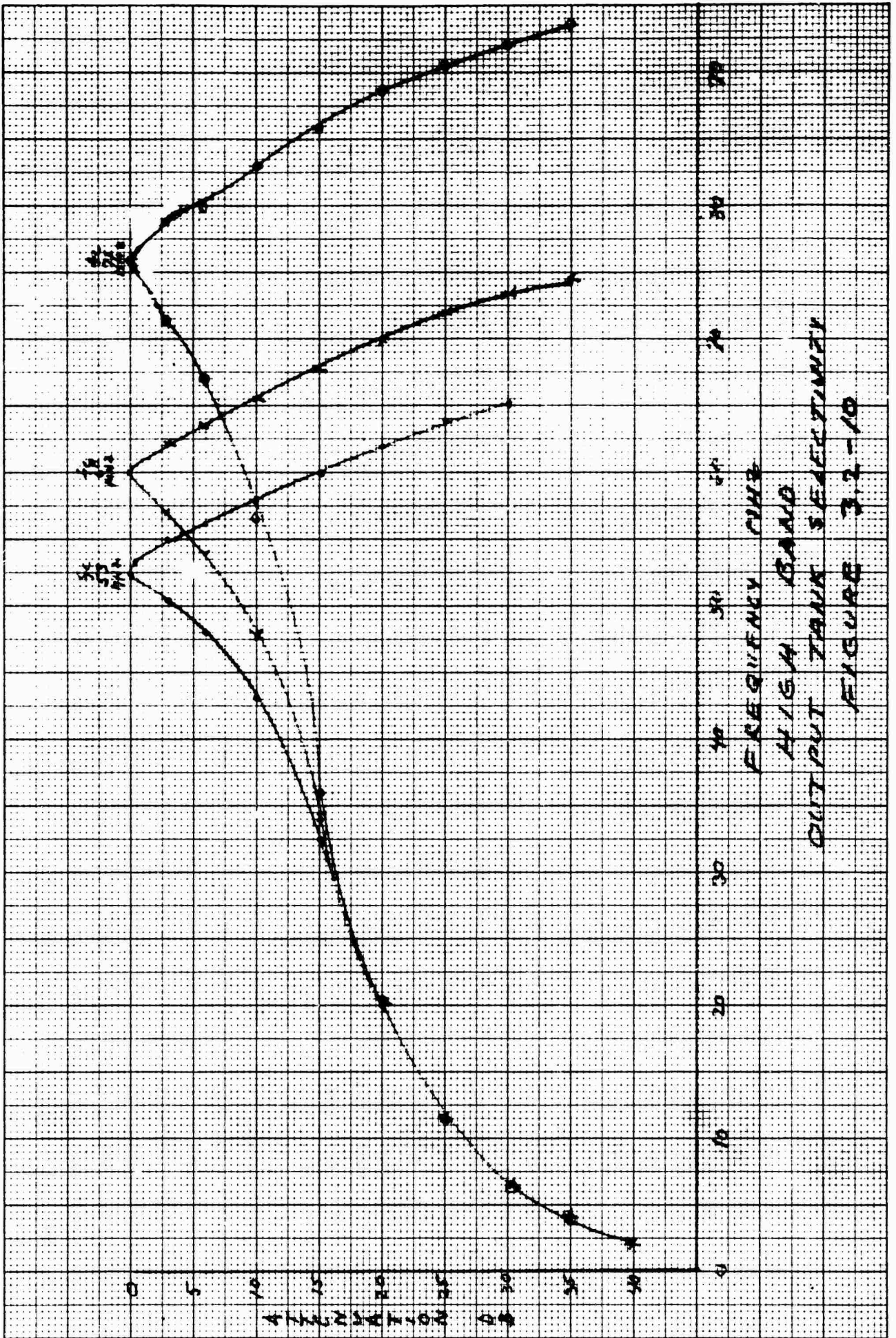

would be decreased slightly. This would also increase the selectivity of the output tank and the insertion loss. Since the insertion loss is already somewhat higher than it should be (0.7 dB) additional effort to optimize the output tank circuit, the location of the tap and the loop coupling, will be applied.

At this point the Engineering Model Tuner/Driver Assembly, power amplifier, output tank circuit and the output low pass filters were connected together as shown in Figure 3.2-11.

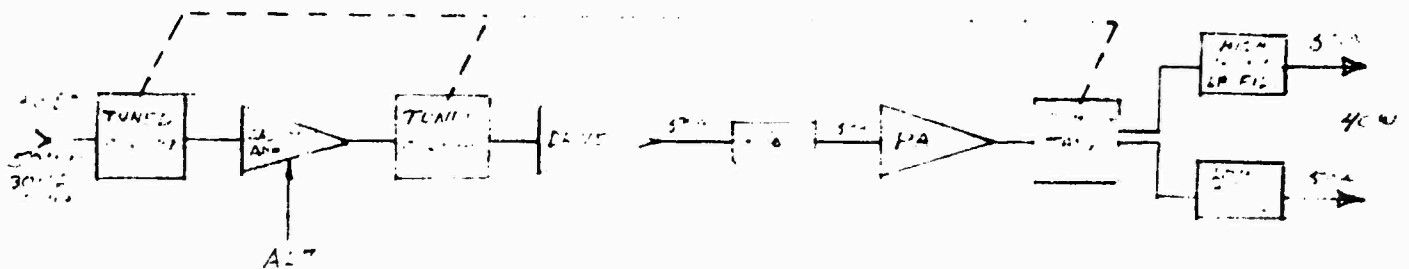

Figure 3.2-11

The reverse intermodulation characteristics were then measured using the test setup shown in Figure 3.2-12. The spectrum analyzer was used to compare the relative amplitudes of the interfering signal and the resulting intermodulation levels. The tests were all conducted with the transmitter developing 40 watts of power at the load. This is considered to be the nominal level for actual field operation. The output level of the Boonton Power Amplifier was adjusted until an interfering signal, as observed on the spectrum analyzer, was 40 dB below the transmitter output. The level of the reverse intermodulation product could then be recorded directly from the spectrum analyzer. All measurements were taken with signal levels well within the dynamic range of the analyzer to prevent any possible compression.

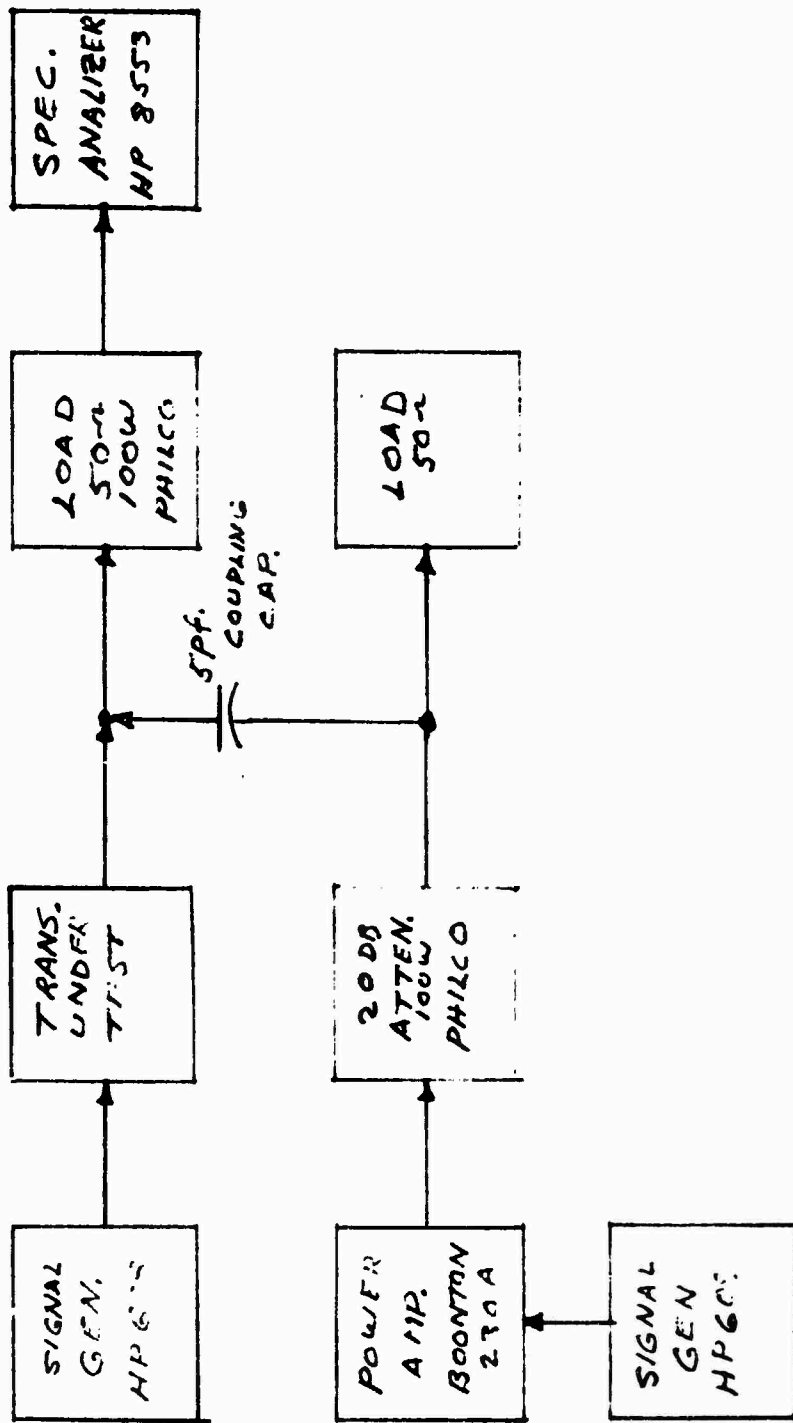

FIGURE 3.2-12
REVERSE INTERMODULATION
TEST SETUP

The data taken on the Engineering Model is included in Figure 3.2-13. It is seen from this preliminary data that the reverse intermodulation levels over most of the band are lower than the required 15 dB. At the two frequencies where the performance is marginal, the interfering signal is on the low side of the transmitter carrier. Improvement in low side selectivity should further attenuate the resulting intermodulation products.

Transmitter Frequency MHz	Interference Frequency MHz	Intermodulation Frequency MHz	Intermodulation Level DM	Power Output W
30	32	28	22	40
30	28	32	23	40
35	37	33	16	40
35	33	37	18	40
40	42	38	20	40
40	38	42	24	40
45	47	43	22	40
45	43	47	12	40
50	52	48	24	40
50	48	52	29	40
55	57	53	22	40
55	53	57	27	40
60	62	58	22	40
60	58	62	25	40
65	67	63	15	40
65	63	67	13	40
70	72	68	16	40
70	68	72	18	40
76	78	74	22	40
76	74	78	27	40

FIGURE 3.2-13

3.3 Power and Control Circuits

The power supply for the power amplifier will provide not only voltage regulation at 24 volts output, but current limiting as well. This added degree of protection for the power amplifier will prevent possible damage during field service or under adverse field conditions. The current limiter will limit around 5 amps. Any current in excess of 5 amps will cause the regulator to instantly drop the voltage to limit the current. When the adverse load is removed, the voltage will be restored automatically and normal current provided.

A breadboard circuit has been constructed and bench tested. This circuit is shown in Figure 3.3-1. Initial data recorded on this regulator is included in Figure 3.3-2 below.

<u>E_{in}</u> <u>Volts</u>	<u>E_{out}</u> <u>Volts</u>	<u>I_{load}</u> <u>Amps</u>	
22	20.7	4	
24	22.6	4	
25.5	24.1	4	
28	25.0	4	
30	25.2	4	
25.5	24.2	2.5	
25.5	24.2	3.0	
25.5	24.2	3.5	
25.5	24.1	4.0	
25.5	24.0	4.5	
25.5	3.5	4.6	<-- Current Limit set at 4.5 amps

Figure 3.3-2

The regulator will be located on the heat sink presently used for the existing 700 V plate supply. The 700 volt supply will be removed and the 400 μ fan supply converted to silicon transistors. An Engineering Model is being constructed at this time for testing with the power amplifier.

The Automatic Level Control (ALC) will maintain the

output power developed into 50 ohms, constant across the 30 MHz to 76 MHz band. This will be accomplished by sampling the output power, comparing it to a reference and adjusting the gain of the Tuner/Driver assembly accordingly. The forward power bridge used to sample the power delivered to the load will be located after the output tank circuit. This location will allow measurements which are relatively free from harmonic content (30 dB down).

The output power level can be changed from high power to low power by switching in a different reference voltage for the bridge. This will be controlled by the High/Low power switch on the front panel of the radio set. The power bridge and its associated circuitry will be located in the old tube socket housing in such a way that the level controls will be adjustable from the top of the radio set. The series pass regulator which controls the collector voltage of the cascode amplifier and thus the gain, is located directly on the heat sink next to the Tuner/Driver assembly.

A circuit has been breadboarded and tested under standard test conditions. The circuit is shown in Figure 3.3-3. The loop was closed with the Tuner/Driver assembly, PA, output tank circuit, low pass filters and the bridge control circuit. Data was recorded with the high power control set for 40 watts. Figure 3.3-4 below, shows the variation of power across the band. It is seen that there is less than a 0.2 dB mean power variation.

Frequency MHz	Output Power W
30	39.9
40	40
50	37.2
56	39
66	40
76	39.2

Figure 3.3-4

3.4 Mechanical Packaging

The mechanical packaging of the solid state design is based on the retention of the following components:

- a) Heat sink (transmitter)
- b) Fan and power supply
- c) Output tank circuit
- d) Tuner
- e) Low band low pass antenna filter

Utilizing the above components the solid state design is packaged in the following locations:

<u>New Design</u>	<u>Location</u>
Tuner/Driver Assembly	Same location as A6100
Power Amplifier	Same location as A6200
Output Tank Circuit	Same location as A6200
Power Bridge and Control Circuitry	Same location as A6200
PA Regulator	Transistors on A9400 circuit on A9000
400 μ Power Supply	Transistors on A9400 circuit on A9000
High Band Low Pass Filter	On A9000

Existing mechanical gear trains, couplings and front panel controls will be used in the same manner as before.

4.0 CONCLUSIONS

An RF amplifier has been demonstrated using a single transistor in class C operation which develops sufficient power across the 30 MHz to 76 MHz band to meet the 35 watt minimum power specified. The design has been successfully incorporated within the limited space available and adequately heat sunk to operate well within its temperature limits.

A Tuner/Driver assembly has been designed utilizing the existing tuner and providing sufficient gain to drive the power amplifier.

Additional progress has been made on the design of the regulators and ALC circuitry.

It is expected that with the initial integration tests starting earlier than originally planned, that any problems resulting from these tests can be resolved in a more timely fashion.

APPENDIX

VHF Power Transistors

JO1006...100-180MHz, 100Watts

Infinite VSWR at Rated Power

@ 180MHz, 28 Volts

Diffused, Silicon Ballast Resistors

All Gold Metal System

Class A, B, C and Pulsed Operation



J-Zero-C

The JO1006 is an internally matched NPN silicon VHF transistor. Its computerized thermal, multicell design provides optimum heat dissipation and operating efficiency. Ruggedability and long term

reliability is guaranteed by unique, diffused silicon ballasting resistors coupled with TRW's refractory gold-passivated metalization system.

Absolute Maximum Ratings ($T_{CASE} = 25^{\circ}C$)

TRW Type	V_{CEO}	V_{CES}	V_{EBO}	I_C	T_{STG}	T_J	θ_K	$P_T @ 25^{\circ}C$
JO1006	35V	60V	4V	12A	-65 to 200°C	-65 to 200°C	0.88°C/W*	150W*

*See graph on Page 2. θ_K vs T_{CASE}

Electrical Characteristics ($T_{CASE} = 25^{\circ}C$), 100% Tested and Guaranteed

Symbol	Characteristics	Test Conditions	Value
V_{EBO}	Emitter-Base Breakdown	$I_E = 5mA$	4Vdc
V_{CES}	Collector-Emitter Breakdown	$I_C = 100mA$	60Vdc
V_{CEO}	Collector-Emitter Breakdown	$I_C = 50mA$	35Vdc
I_{CES}	Collector-Emitter Cutoff Current	$V_{CE} = 25V$	10mA Max
h_{FE}	DC Current Gain	$I_C = 1A, V_{CE} = 10V$	20-150
C_{μ}	Collector-Base Capacitance	$V_{CB} = 28V, f = 1MHz$	200pF Max
P_{gain}	Power Output		100W
	Power Input	$V_{CE} = 28V, f = 175MHz$	20W
	Power Gain, dB		7dB Min
η	Collector Efficiency	$V_{CE} = 28V, f = 175MHz$	60% Typ
VSWR	Mismatch Tolerance	$V_{CE} = 28V, W = 100W, f = 175MHz$	∞
P_{sat}	Saturated Power Output	$V_{CE} = 28V, f = 175MHz$	125W

*U.S. Patent #3,712,006

Class C Narrowband Power Input vs Power Output

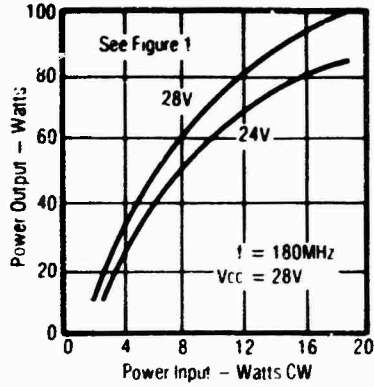

Class B Narrowband Power Input vs Power Output

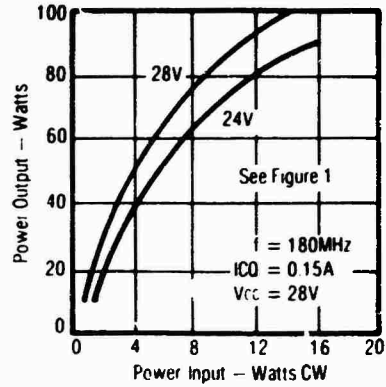

Class C Narrowband Power Gain vs Frequency

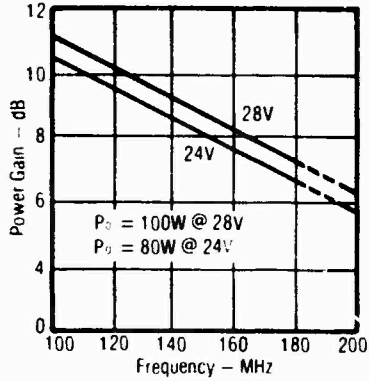

Narrowband f_t vs I_c

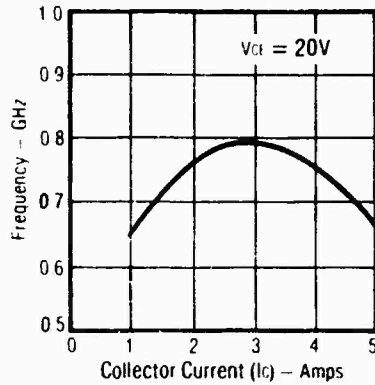

Broadband Power Gain vs Frequency

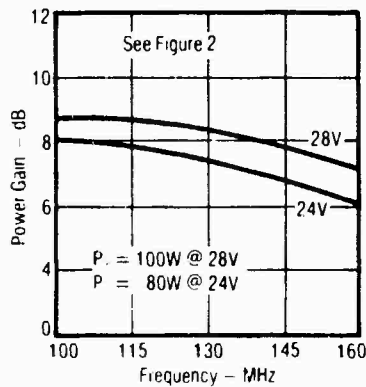

Series Input Impedance vs Frequency

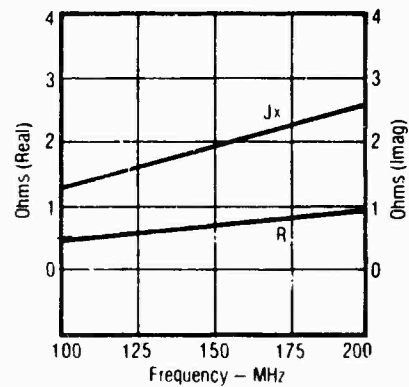

θ_{jc} vs T_{case}

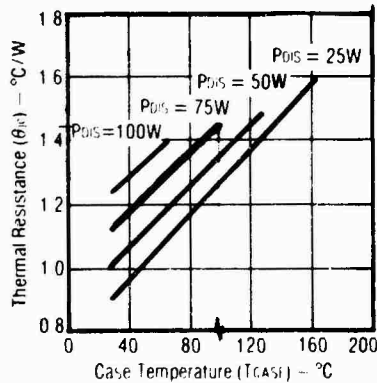

DC Safe Operating Area

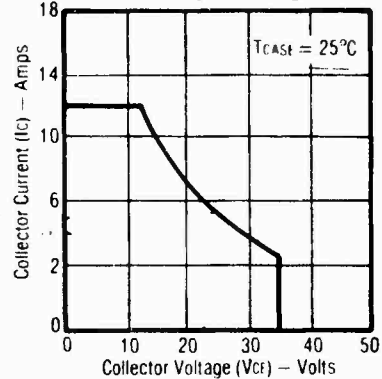

Class A Narrowband Power Input vs Power Output

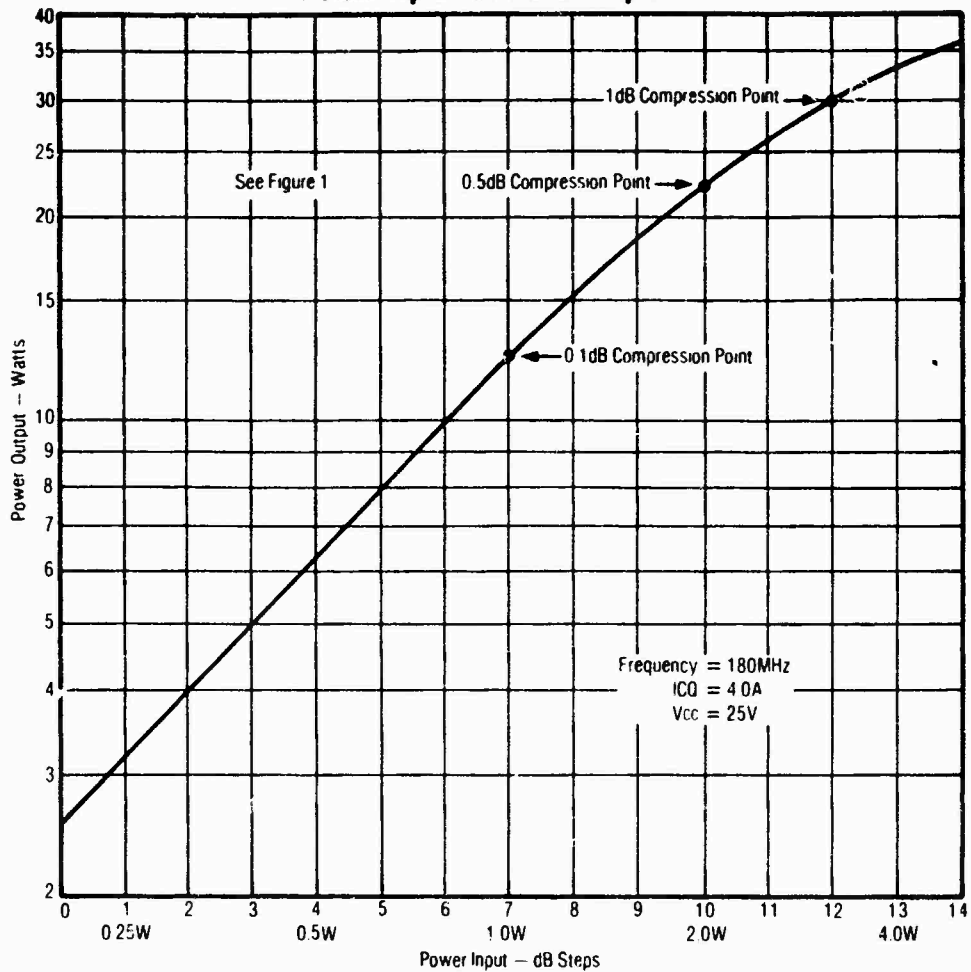

MTTF Factor vs Junction Temperature

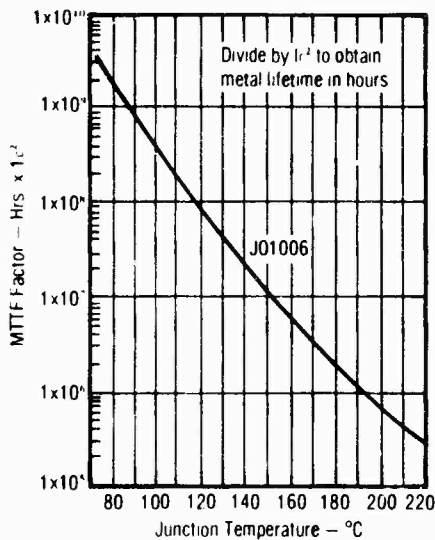

Where:

$$P_o = 100W$$

$$\eta_c = 60\%$$

$$G_r = 7dB$$

$$T_{case} = 45^\circ C$$

$$\theta_{jc} = 1.25$$

$$V_{cc} = 28V$$

$$P_{DGS} = 87W$$

$$T_1 = 150^\circ C$$

$$MTTF \text{ Factor} = (1 \times 10^7 \text{ hrs})(amp^4)$$

$$MTTF \text{ (hr)} = \frac{(1 \times 10^7 \text{ hrs})(amp^4)}{(5.95 \text{ amp})^4}$$

$$= 2.8 \times 10^4 \text{ hrs}$$

$$= 32 \text{ yrs}$$

J-Zero-C Package Outline

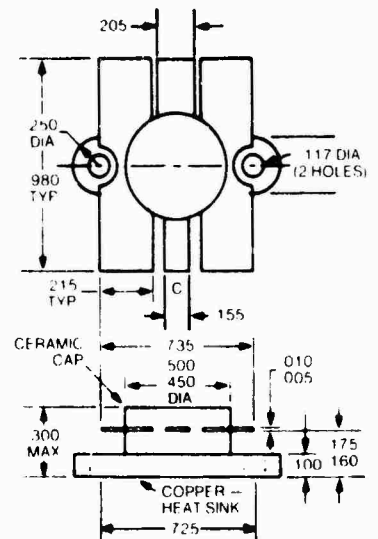
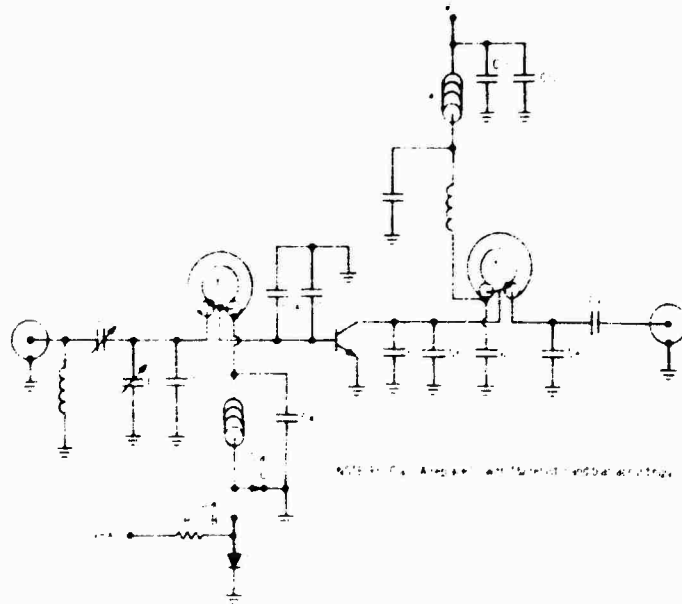
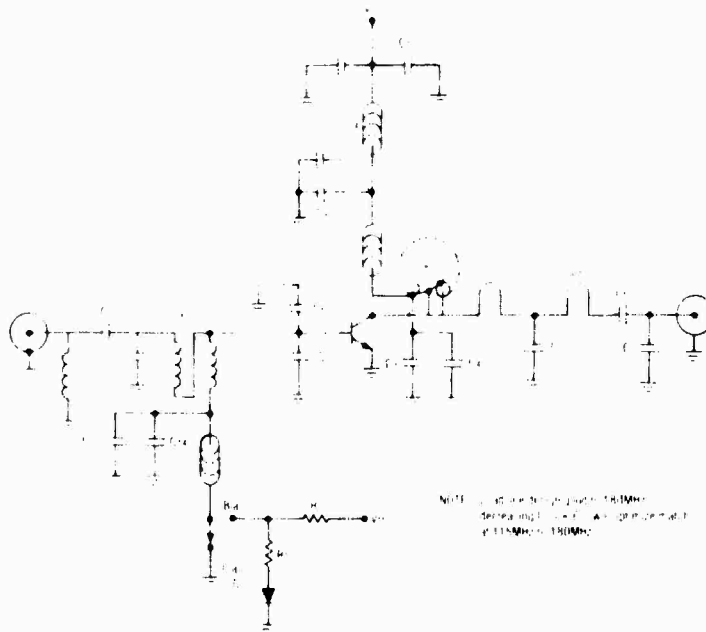

Figure 1. JO1006 Narrowband Test Circuit (100-180MHz)



C1	8.60pF ARCO	C13	350pF UNELCO
C2	3.35pF ARCO	C14	300pF UNELCO
C3	30pF UNELCO	D1	DSR5050
C4,7,9,10,11	1000pF UNELCO	L1	5 turns, 0.125" diameter #22AWG
C5	110pF UNELCO	L2,4	3 Ferrite beads
C6	120pF UNELCO	R1	12Ω
C8	40pF UNELCO	T1	0.075" diameter semiridged 10Ω co-ax
C12	25μF Electrolytic	T2	0.075" diameter semiridged 25Ω co-ax

Figure 2. JO1006 Broadband Test Circuit (100-160MHz)



C1	50pF UNELCO	L1	4 turns, 0.125" diameter #22AWG
C2	350pF UNELCO	L2,3,4	3 Ferrite Beads on #22AWG
C3,6,9,12,14	1000pF UNELCO	L5	0.08" wide ribbon, 0.25" long
C4,10,13	0.1μF disc	L6	0.08" wide ribbon, 0.125" long
C5,15	30pF UNELCO	R1	1Ω
C7	0.18pF #402 ARCO	R2	50Ω
C8	300pF UNELCO	T1	1" long twisted pair #22AWG
C11	100μF Electrolytic	T2	0.075" diameter semiridged 25Ω co-ax,
D1	DSR5050		2" long (Balun transformer)

TRANSISTOR CORPORATION

2N6369 ● 80 WATT

(BM80-28)

175 MHz ● 28 VOLT RF POWER TRANSISTOR WITH INTERNAL MATCHING

GENERAL DESCRIPTION-This device is specifically designed for broadband high power VHF operation providing 80 watts of RF power output from a 28 volt supply and operating over the frequency range of 70-220 MHz.

FEATURES

- SUPERIOR POWER PERFORMANCE FROM A 28 VOLT SUPPLY.
- MAXIMUM RELIABILITY DUE TO SINGLE CHIP CONSTRUCTION.
- SPECIFICALLY DESIGNED FOR BROADBAND 28 VOLT OPERATION COVERING THE FREQUENCY RANGE OF 70-220 MHz.
- GUARANTEED TO WITHSTAND 5:1 VSWR AT ALL PHASE ANGLES WHEN OPERATED AT RATED POWER AND SUPPLY VOLTAGE.
- IDEAL FOR USE IN LINEAR APPLICATIONS REQUIRING OPERATION IN CLASS AB DUE TO IMPROVED FORWARD BIASED SAFE AREA.
- MAXIMUM BANDWIDTH DUE TO LOW Q INPUT MATCHING.
- EXCELLENT FOR HIGH POWER COMBINING WITH THE MINIMUM NUMBER OF DEVICES.

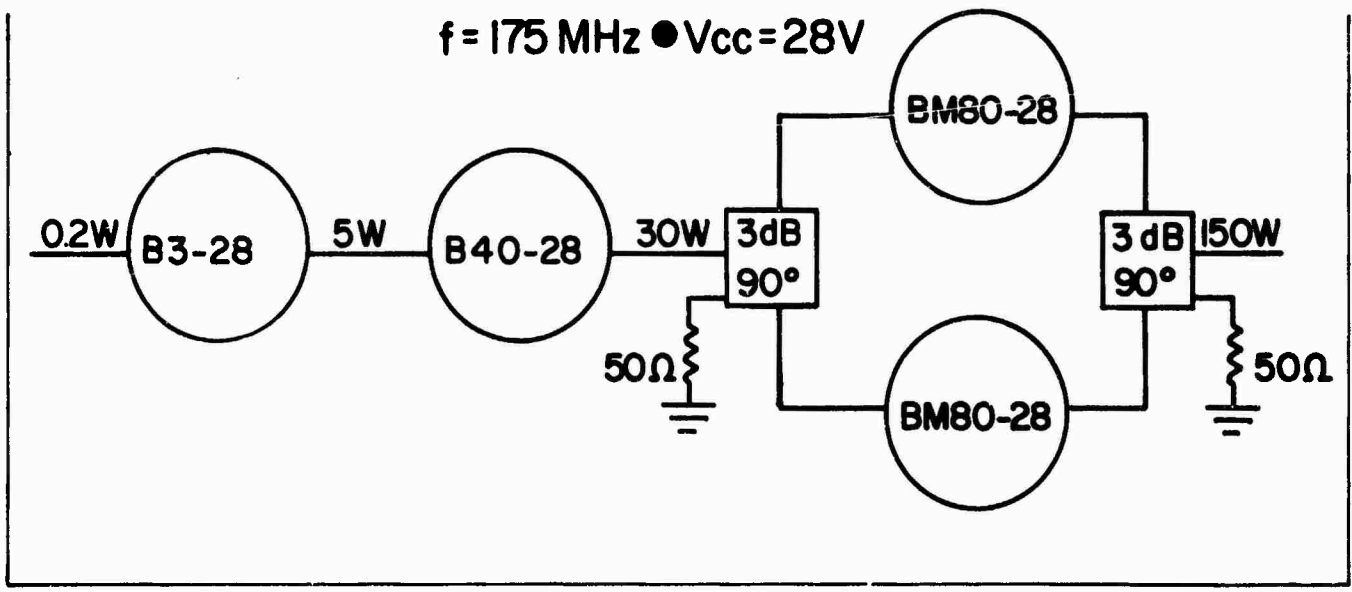
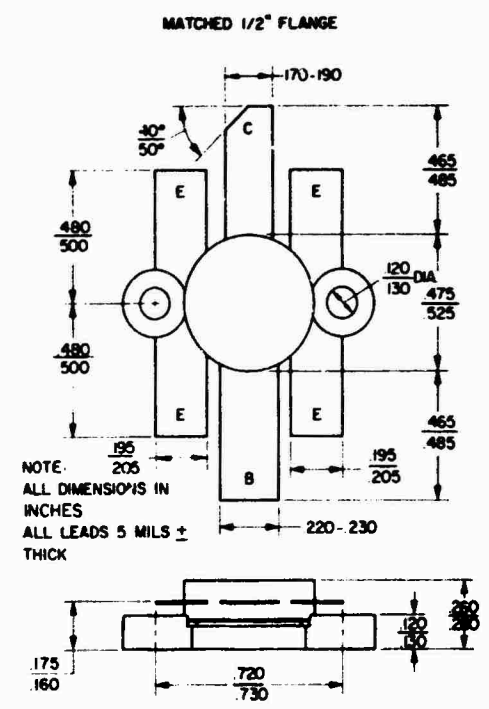

4C

COMMUNICATION TRANSISTOR 2N6369

ELECTRICAL CHARACTERISTICS

ABSOLUTE MAXIMUM RATINGS

MAXIMUM TEMPERATURES

BM80-28

Storage Temperatures	-65° C to +200° C
Operating Junction Temperatures	200° C
Lead Temperature (Soldering 8 seconds time limit)	
1.32" from Ceramic	260° C

MAXIMUM POWER DISSIPATION (Note 1)

Total Power Dissipation at 25° C Case Temperature	220 W
---	-------

MAXIMUM VOLTAGES AND CURRENT

V_{CES} Collector to Emitter Voltage	60 V
V_{EBO} Emitter to Base Voltage	4 V
V_{CEO} Collector to Emitter Voltage	33 V
I_C Collector Current	20 A

ELECTRICAL CHARACTERISTICS (25° C unless otherwise specified)

SYMBOL	CHARACTERISTICS	MIN.	TYP.	MAX.	UNITS	TEST CONDITIONS
P_{OUT}	Power Output (Note 2)	80			WATTS	$f = 175 \text{ MHz}$, $V_{CC} = 28 \text{ V}$
P_{IN}	Power Input (Note 2) (At Rated Power Out)			15	WATTS	$f = 175 \text{ MHz}$, $V_{CC} = 28 \text{ V}$
η	Collector Efficiency (At Rated Power Out)	50	60		%	$f = 175 \text{ MHz}$, $V_{CC} = 28 \text{ V}$
Z_{IN}	Series Input Impedance		$1.0 + j2.5$		OHMS	At rated output power and frequency
Z_L	Series Load Impedance		$2.2 + j0$		OHMS	At rated output power and frequency
C_{CB}	Collector to Base Capacitance ($f = 1.0 \text{ MHz}$)			200	pF	$V_{CB} = 28 \text{ V}$, $I_E = 0$
V_{CEO}	Collector to Emitter Voltage	35			VOLTS	$I_C = 50 \text{ mA}$, $I_B = 0$
V_{EBO}	Emitter to Base Voltage	4.0			VOLTS	$I_C = 0$, $I_E = 5 \text{ mA}$
V_{CES}	Collector to Emitter Voltage	60			VOLTS	$I_C = 20 \text{ mA}$

NOTES:

- This rating gives a maximum junction temperature of 200° C with junction to case thermal resistance of 0.8° C/watt.
- Values measured in 175 MHz test amplifier (Fig. 1).

175 MHz TEST AMPLIFIER (FIG. 1)

- C_1, C_2, C_3, C_4 - ELMENCO TYPE 404
 C_5 - 2ea 33pf UNDERWOOD ELECTRIC
 C_6 - 68 pf UNDERWOOD ELECTRIC
 C_7 - 0.01 DISC CERAMIC RMC TYPE JF
 C_8 - 10ufd 50VDC SPRAGUE TE1304
 C_9 - 500pf UNDERWOOD ELECTRIC
 C_{10} - 0.47 ERIE RED CAP TYPE 8131-100-651-474M
 RFC_1, RFC_2 - 0.22uh NYTRONICS INDUCTOR TYPE SWD-0.22
 L_1 - 2-1/2 TURNS #18 3/8" I.D.

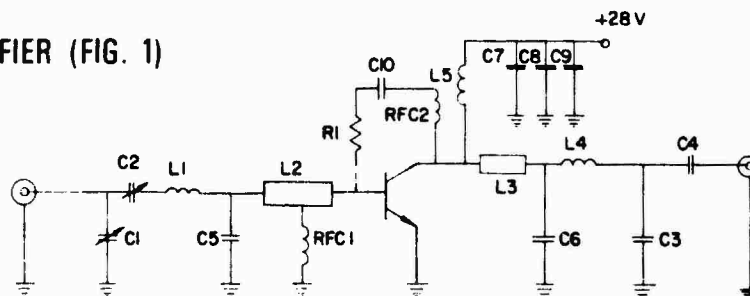

- L_2 - 1" x 1/4" x 10 MIL COPPER STRAP
 L_3 - 1/2" x 1/4" x 10MIL COPPER STRAP
 L_4 - 1-1/2" #16 HAIR PIN COIL
 L_5 - 6 TURNS #18 ON 3/8" I.D.
 R_1 - 10.Ω 1/2 W RESISTOR (CARBON)

COMMUNICATION TRANSISTOR 2N6369

POWER OUTPUT VERSUS POWER INPUT

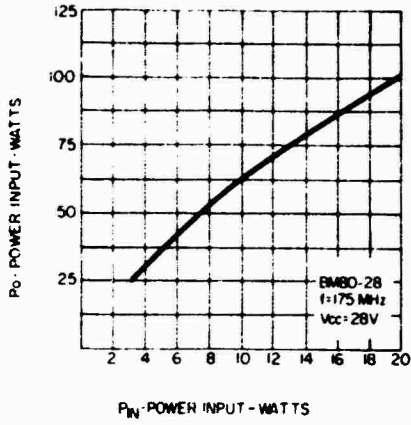

POWER GAIN VERSUS FREQUENCY

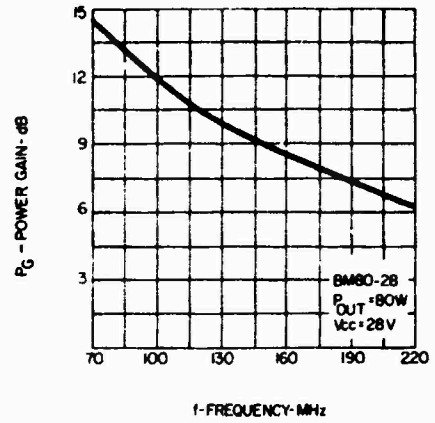

SERIES INPUT IMPEDANCE VERSUS FREQUENCY

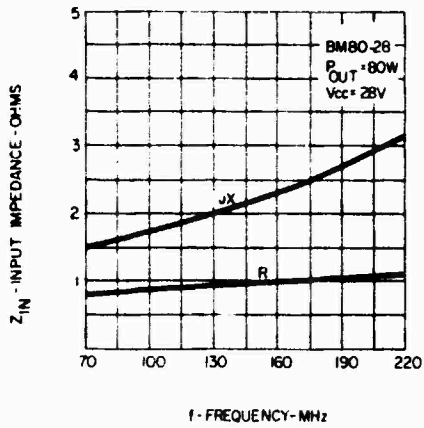

SERIES LOAD IMPEDANCE VERSUS FREQUENCY

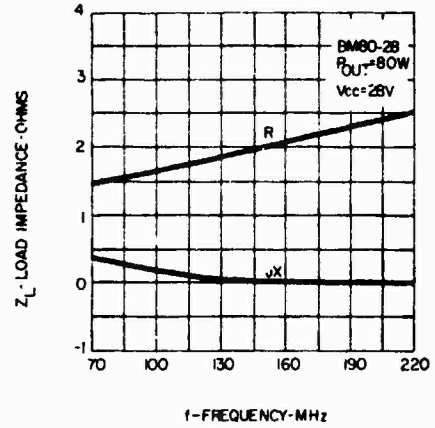

DC SAFE OPERATING AREA

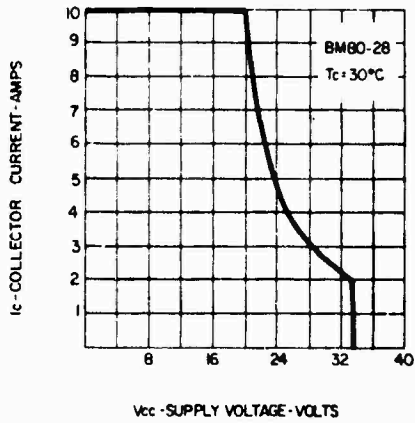

f_t VERSUS I_C

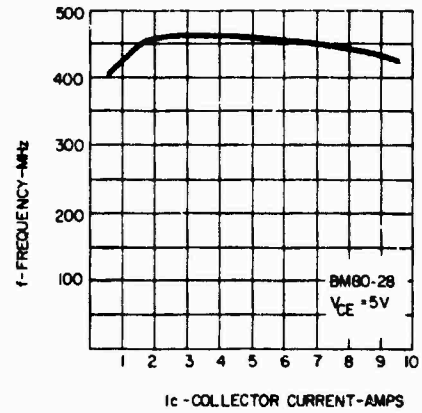

COMMUNICATION TRANSISTOR 2N6369

70-170 MHz ● 80W ● BROADBAND AMPLIFIER

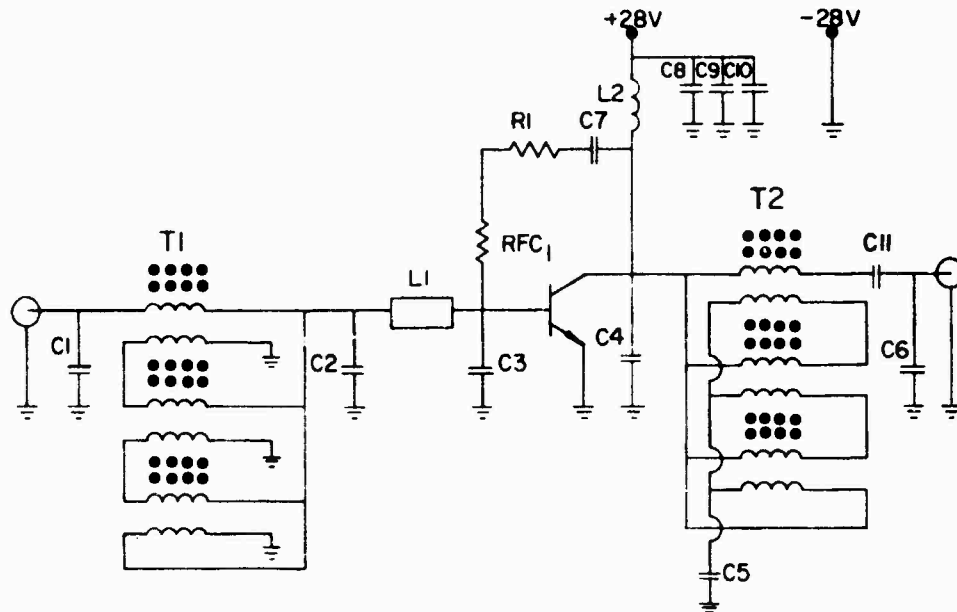

T1, T2 - 16:1 COAXIAL TRANSFORMER
 COAX: $Z_0 = 10 \Omega$
 $l = 5$ INCHES
 TURNS: 2 EACH CORE
 PRECISION TUBE CO., INC.
 # DA 10070
 CORE: FERROXCUBE
 # K5-050-06-1Z2

C1, C6 - ATC 100 1 EACH 20 pf
 C2 - ATC 100 2 EACH 300 pf
 C3 - ATC 100 2 EACH 300 pf
 C4 - ATC 100 2 EACH 75 pf
 C5 - ATC 700 1 EACH 1000 pf

C7 - ERIE RED CAP 0.47 μ fd
 C8 - ERIE RED CAP 0.01 μ fd
 C9 - ERIE RED CAP 1000 pf
 C10 - SPRAGUE TE1303
 5 μ fd @ 50V
 L1 - COPPER STRAP .400" x .200"
 L2 - 6T #16 1/4" I.D.
 R1 - 10 Ω 1W
 RFC1 - 0.22 μ h
 C11 - ALLEN BRADLY .001 μ fd
 FEED THRU

POWER INPUT vs FREQUENCY

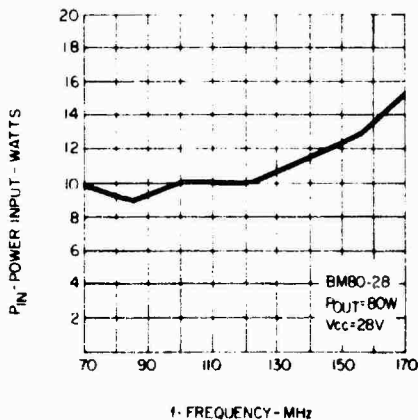

INPUT MATCH vs FREQUENCY

