

AD-A020 547

95-GHz RADAR MEASUREMENTS

J. W. Battles

Naval Weapons Center  
China Lake, California

November 1975

DISTRIBUTED BY:

**NTIS**

National Technical Information Service  
U. S. DEPARTMENT OF COMMERCE

ADAU20547

# 95-GHz Radar Measurements

by

J. W. Battles  
*Research Department*

NOVEMBER 1975

Approved for public release; distribution unlimited.

RECEIVED  
D D G

Reproduced by  
**NATIONAL TECHNICAL  
INFORMATION SERVICE**  
US Department of Commerce  
Springfield, VA. 22151

# Naval Weapons Center

CHINA LAKE, CALIFORNIA 93555

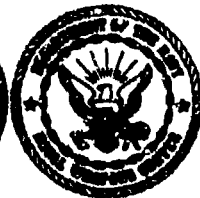

# Naval Weapons Center

AN ACTIVITY OF THE NAVAL MATERIAL COMMAND

R. G. Freeman, III, RADM, USN ..... Commander

G. L. Hollingsworth ..... Technical Director

## FOREWORD

The work reported here is part of a larger study to determine the technical options offered by millimeter wave systems. This study, supported by Independent Exploratory Development funds, was completed in October 1974.

The report has been reviewed for technical accuracy by D. J. White and F. C. Essig. Because of the preliminary nature of this study, refinements and modifications may later be made in the methods and the measurements discussed.

Released by  
**FRED C. ESSIG, Head**  
*Physics Division*  
15 September 1975

ABSTRACTOR	
DTIC	Wave Section <input checked="" type="checkbox"/>
DDC	Diff Section <input type="checkbox"/>
UNCLASSIFIED	<input type="checkbox"/>
CLASSIFICATION	
OF	
DISTRIBUTION STATEMENTS	GROUPS
1	AL

*R*

Under Authority of  
**HUGH W. HUNTER, Head**  
*Research Department*

NWC Technical Publication 5803

Published by ..... Technical Information Department  
Collation ..... Cover, 14 leaves  
First printing ..... 75 unnumbered copies

UNCLASSIFIED

SECURITY CLASSIFICATION OF THIS PAGE (When Data Entered)

REPORT DOCUMENTATION PAGE		READ INSTRUCTIONS BEFORE COMPLETING FORM
1. REPORT NUMBER NWC TP 5803	2. GOVT ACCESSION NO.	3. RECIPIENT'S CATALOG NUMBER
4. TITLE (and Subtitle) 95-GHz RADAR MEASUREMENTS	5. TYPE OF REPORT & PERIOD COVERED RESEARCH REPORT	
	6. PERFORMING ORG. REPORT NUMBER	
7. AUTHOR(s) J. W. Battles	8. CONTRACT OR GRANT NUMBER(s)	
9. PERFORMING ORGANIZATION NAME AND ADDRESS Naval Weapons Center China Lake, CA 93555	10. PROGRAM ELEMENT, PROJECT, TASK AREA & WORK UNIT NUMBERS Program Element 62766N Task F61112U01	
11. CONTROLLING OFFICE NAME AND ADDRESS	12. REPORT DATE November 1975	
	13. NUMBER OF PAGES 26	
14. MONITORING AGENCY NAME & ADDRESS (if different from Controlling Office)	15. SECURITY CLASS. (of this report) Unclassified	
	15a. DECLASSIFICATION/DOWNGRADING SCHEDULE	
16. DISTRIBUTION STATEMENT (of this Report) Approved for public release; distribution unlimited.		
17. DISTRIBUTION STATEMENT (of the abstract entered in Block 20, if different from Report)		
18. SUPPLEMENTARY NOTES		
19. KEY WORDS (Continue on reverse side if necessary and identify by block number) Millimeter wave                      Mapping Radar                                      Identification Pulse Doppler		
20. ABSTRACT (Continue on reverse side if necessary and identify by block number) See back of form.		

UNCLASSIFIED

SECURITY CLASSIFICATION OF THIS PAGE(When Data Entered)

(U) *95-GHz Radar Measurements*, by J. W. Battles.  
China Lake, Calif., Naval Weapons Center, November  
1975. 26 pp. (NWC TP 5803, publication UNCLASSIFIED.)

(U) A 95-GHz radar was operated in a pulsed and  
a continuous-wave Doppler mode to demonstrate its  
ability to map, detect, and identify specific targets.

11

UNCLASSIFIED

SECURITY CLASSIFICATION OF THIS PAGE(When Data Entered)

## INTRODUCTION

In the last few years it has become increasingly apparent that millimeter wave systems have important potential for use in future Navy weapon systems. A 95-gigahertz (GHz) radar was brought to the Naval Weapons Center from the Naval Air Development Center (NADC), Warminster, Pa., in order to examine possible applications. The radar was operated in a pulsed and a continuous wave (CW) Doppler mode to demonstrate its ability to map, detect, and identify specific targets. Tests were designed to look into areas of application about which little or no work has been published. Because of the limited time available for this study, the tests were of a preliminary nature.

The mapping potential of a ground-level radar to monitor vehicle movements and returns from power lines, power poles, the muzzle blast of a 155-mm howitzer, and various other targets was examined. In addition, Doppler returns from various moving targets were recorded and studied.

## 95-GHz RADAR MODES OF OPERATION

The 95-GHz radar was operated as a pulsed radar and as a homodyne CW Doppler radar. A 6-kilowatt magnetron was used as the transmitter source in the pulsed mode and a 30-milliwatt klystron was used as the transmitter in the CW Doppler mode. A telescope was used in all cases for antenna alignment. Mapping and return signal strength measurements were made with the pulsed radar. Target identification studies were made with the Doppler radar.

Figure 1 is a block diagram of the mapping configuration. Since the PPI scope was difficult to photograph, a B-scope was used for the map photographs. The 24-inch-diameter Cassegrainian antenna was horizontally scanned through 60 degrees and could be vertically step-scanned through a total of 10 degrees. Figure 2 is a block diagram of the pulsed radar set up to measure the return signal level. In this mode the 24-inch antenna was replaced with a 36-inch Cassegrainian

antenna. Table 1 gives the characteristics of the pulsed radar. This radar has been described in detail.<sup>1</sup>

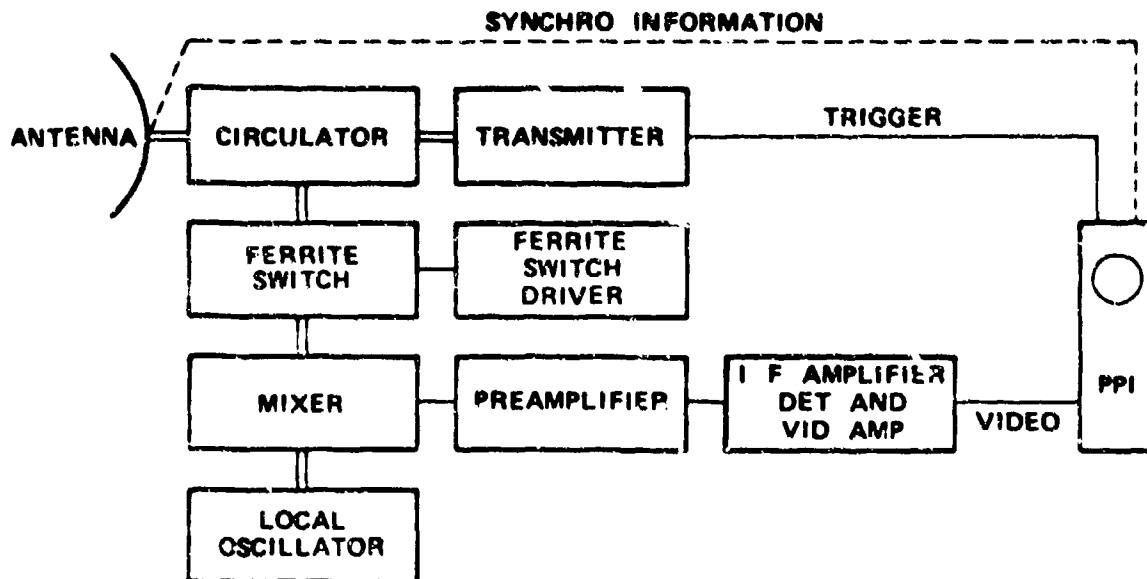

FIGURE 1. Mapping Radar.

<sup>1</sup> Naval Air Development Center. *Millimeter Radar Investigation*, by M. J. Foral. Warminster, Pa., NADC, March 1973. (NADC-73013-20, publication UNCLASSIFIED.) AD 910157L.

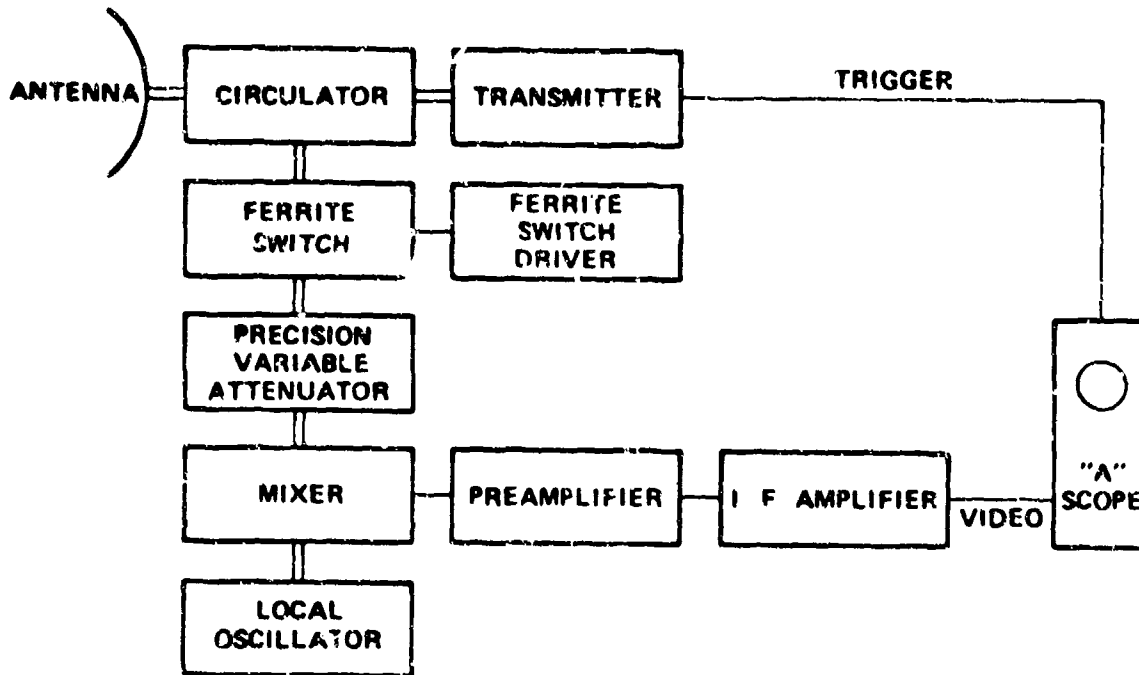

FIGURE 2. Scope Display.

TABLE 1. NADC 95-GHz Radar System Characteristics.

Transmitter:	
Frequency, GHz . . . . .	95
Peak power output, kW . . . . .	6
Pulse repetition frequency, pps . . . . .	1500
Pulse length, $\mu$ sec . . . . .	0.1
Duty cycle . . . . .	0.00015
Average power, W . . . . .	~0.9
Receiver-balance mixer:	
Intermediate frequency, MHz . . . . .	120
Bandwidth, MHz . . . . .	40
Log receiver range, dB . . . . .	80
Antenna:	
Beam width, deg . . . . .	0.38
Gain, dB . . . . .	53

A simple design was used for the 95 GHz homodyne CW Doppler radar. Figure 3 is a block diagram of the system including the data recording equipment. The 36-inch Cassegrainian antenna was kept in place and the 35-milliwatt klystron local oscillator of the pulsed radar was used for the transmitter. The transmitter power was set, using the attenuator, at 3 milliwatts. The energy leakage past the circulator was used as the local oscillator signal for the single-ended mixer. The output of

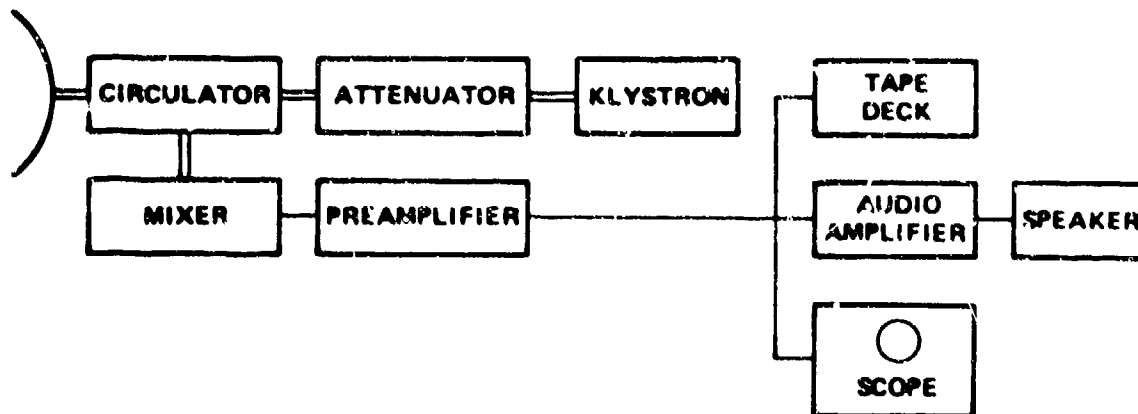

FIGURE 3. Homodyne CW Doppler.

the mixer was run to a preamplifier and then recorded on a magnetic tape. The oscilloscope and the speaker were used to monitor the Doppler signal.

Figure 4 shows the radar with the 24-inch antenna in operating position in the back of a truck. Figure 5 shows the radar at a remote site with the 36-inch antenna in operation. The radar system was mobile and once at a field site the radar could be back in operation within 15 to 20 minutes. The radar was operated for 35 hours in the pulsed mode and for 18.5 hours in the Doppler mode during a 4 1/2-week period with no equipment problems. During this period the radar was transported in the truck for approximately 150 miles, most of which was over unpaved desert mountain roads. The system proved to be very reliable.

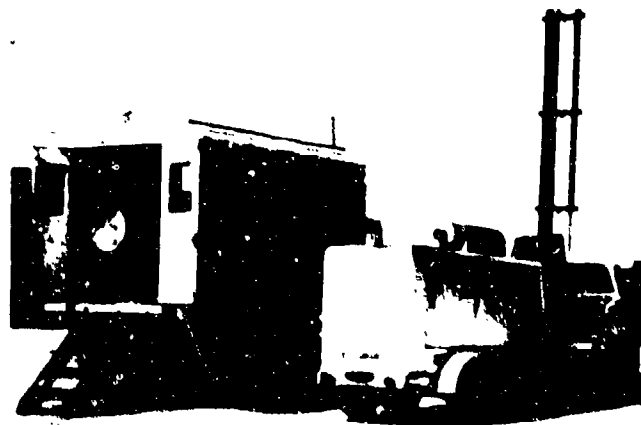

FIGURE 4. Radar With 24-inch Antenna in Operating Position in Truck.



FIGURE 5. Radar With 36-inch Antenna at a Field Site.

#### PULSED MODE DATA

The ability of millimeter wave pulsed radars to make detailed maps has been demonstrated.<sup>2</sup> The mapping results given here are not intended to compete with those of Wilcox as his range resolution is about five times better than ours.

The first radar test site was located on a hill 400 feet above the desert floor. Figures 6, 7, 8, and 9 together give a panoramic view from south to north facing west at this site. Figure 10 is a combined set of B-scope photographs displaying the area shown in Figures 6, 7, and 8. The maximum range shown in Figure 10 is 6 miles. All of targets in Figure 10 can easily be identified with known objects. Figure 11 is the B-scope view of a parking lot at a range of 1 mile. Figure 12 is a composite view, looking south, of a road and a golf course; here the maximum range is 2 miles.

---

<sup>2</sup> Wilcox, F. P. "Development and Test of a 95 GHz Terrain Imaging Radar," in *1974 Millimeter Wave Techniques Conference*. San Diego, Calif., Naval Electronics Laboratory Center, 1974. (NELC/TD 308, Vol. 2, publication UNCLASSIFIED.)

NWC TP 5803

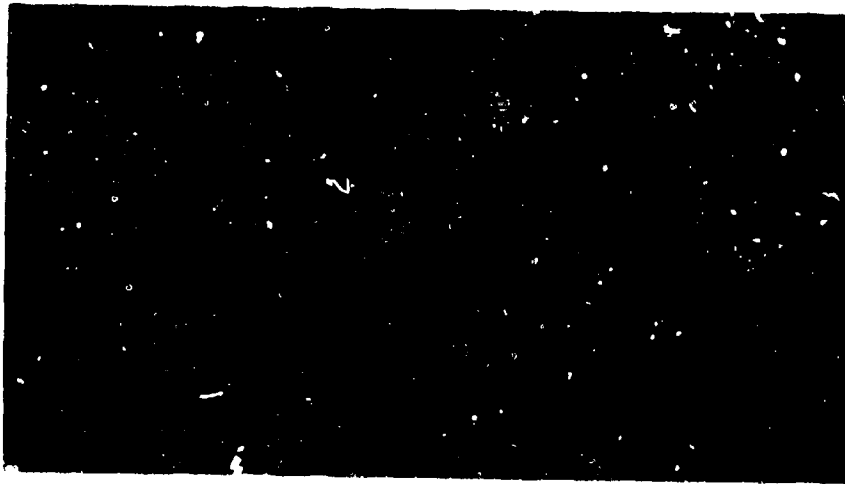

FIGURE 6. Site One, Southern View.



FIGURE 7. Site One, Southwestern View.

NWC TP 5803



FIGURE 8. Site One, Western View.

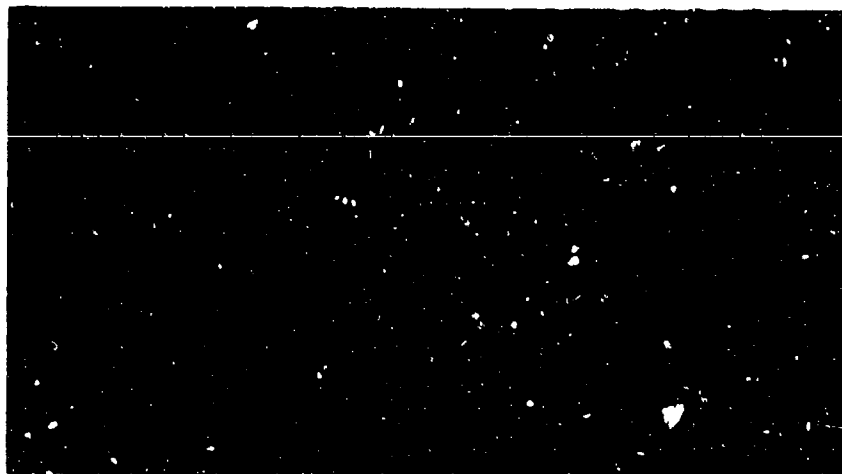

FIGURE 9. Site One, Northwestern View.

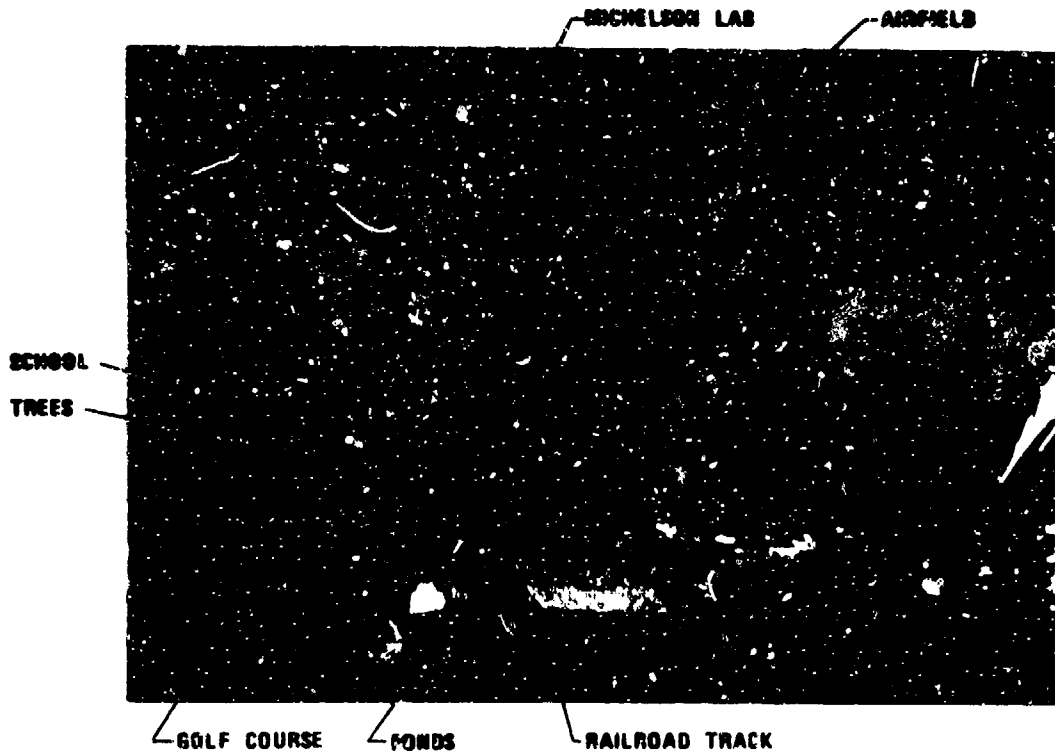

FIGURE 10. Composite B-Scope Display of Area Shown in Figures 6, 7, and 8.

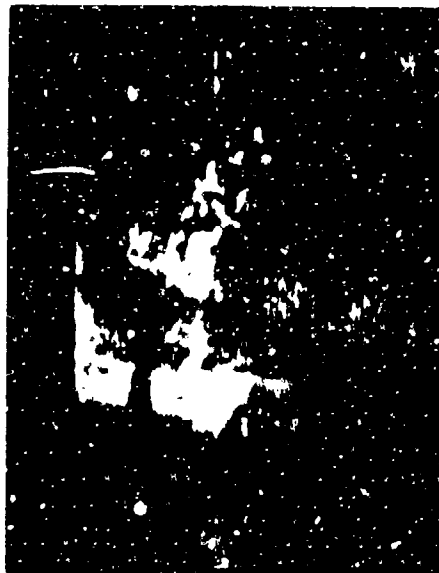

FIGURE 11. B-Scope Display of Parking Area North of Site One. Maximum range shown is 1.5 miles.

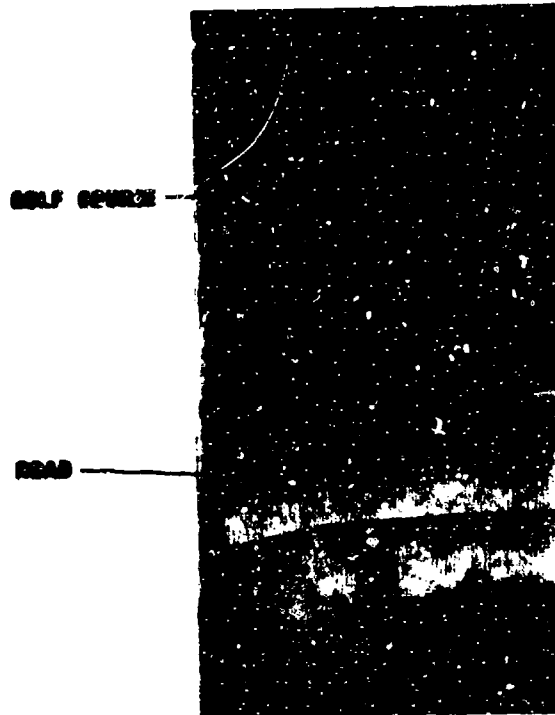

FIGURE 12. B-Scope Display of Road and Golf Course South of Site One.

The radar was then moved down to the desert floor to a site 2 miles west of the first site. At this location the radar was 1,500 feet from a road intersection. The image of the intersection was centered near the bottom of the radar B-scope display. Figure 13 is a 1-mile-range B-scope display with no vehicles on the roads. Figure 14 shows a motorcycle entering the intersection and turning right. Figure 15 shows two cars in the road parallel with the radar beam. The radar was then scanned vertically 10 degrees in order to pick up the hills and the power poles. Figure 16 is two B-scope photographs taken in this mode. The power poles give a strong return and these pictures confirm that the power lines, approximately perpendicular to the beam, also give a strong return. In order to demonstrate this more completely a series of B-scope displays was recorded in which the radar beam was stepped downward 1/4 degree at a time. The first photograph, Figure 17, was taken with the radar just picking up the tops of the power line poles at the intersection. Figure 18 is the B-scope display when the beam had been lowered the first step. Here we are starting to pick up the power lines. In Figures 19 through 22 the radar beam steps down across the power lines and picks up the power poles that run parallel to the beam. In Figures 21 and 22 the bright line that appears in the lower left-hand side is a telephone cable located below the power lines. At

the pole (see arrow) near the left center of Figure 22 it goes underground. During these tests one of the power pole returns was found to be jittering; upon investigation the pole was found to be vibrating in the wind.

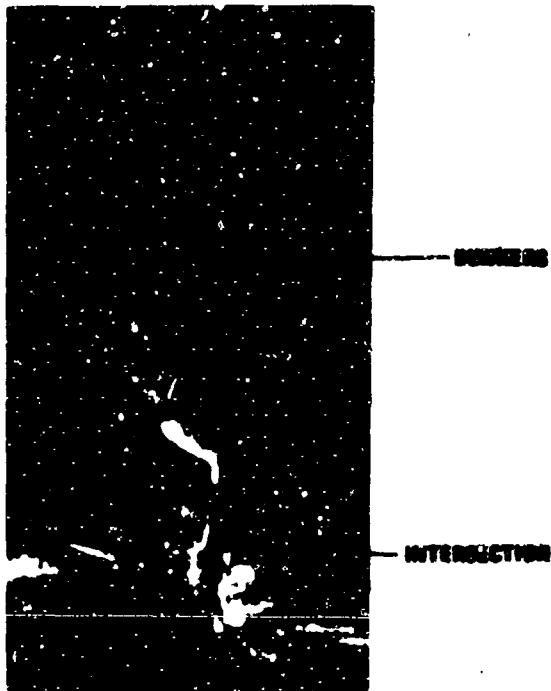

FIGURE 13. B-Scope Display of a Road Intersection. There is no traffic on the roads.

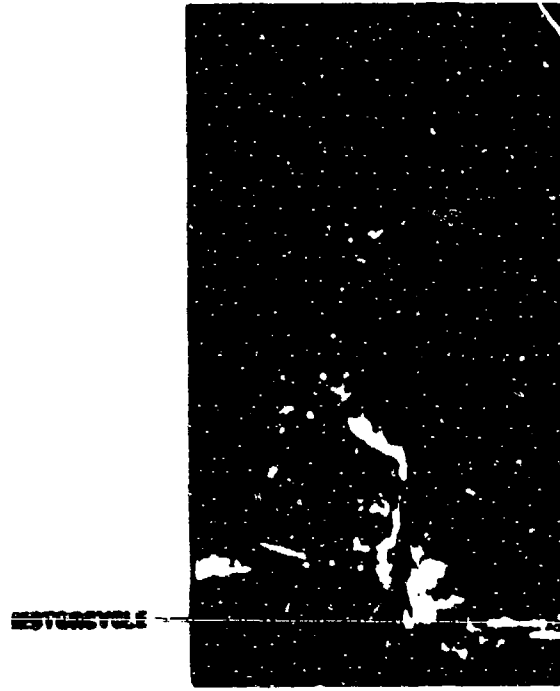

FIGURE 14. Same Intersection Shown in Figure 13 but With Vehicle in Road (at Bottom of Figure).

NWC TP 5803

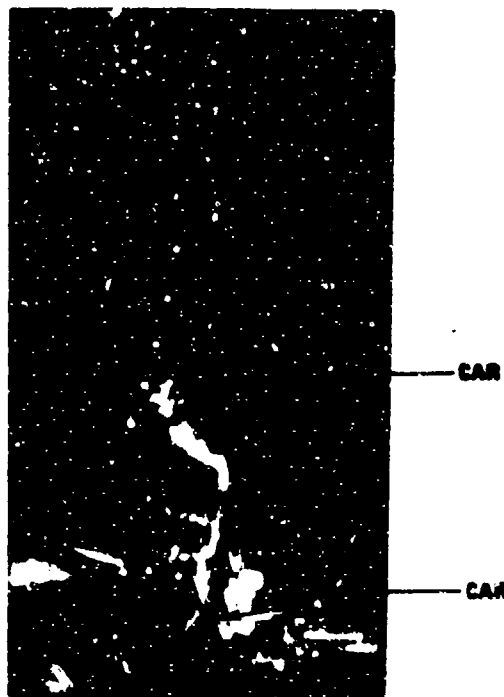

FIGURE 15. Same Intersection Shown  
in Figure 13 but With Two Vehicles  
as Indicated.

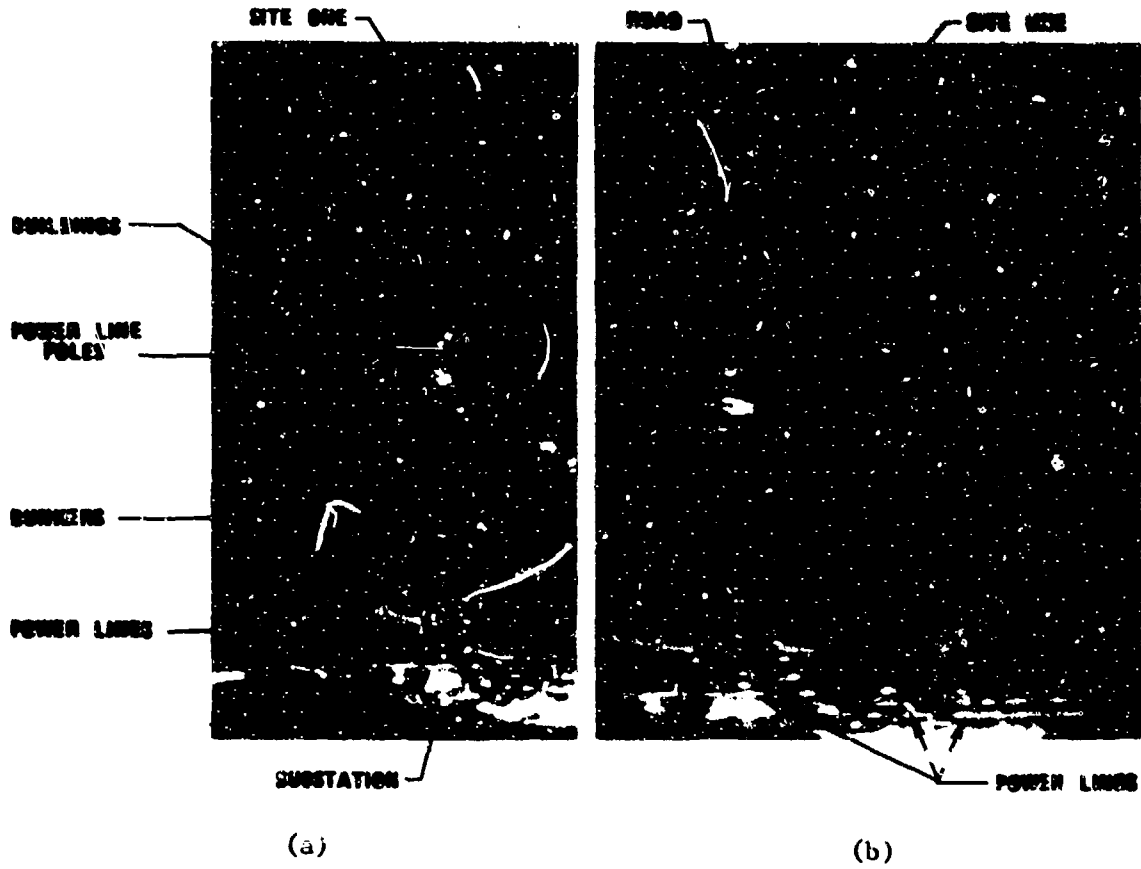

FIGURE 16. B-Scope Display of Intersection Power Lines and Hills.

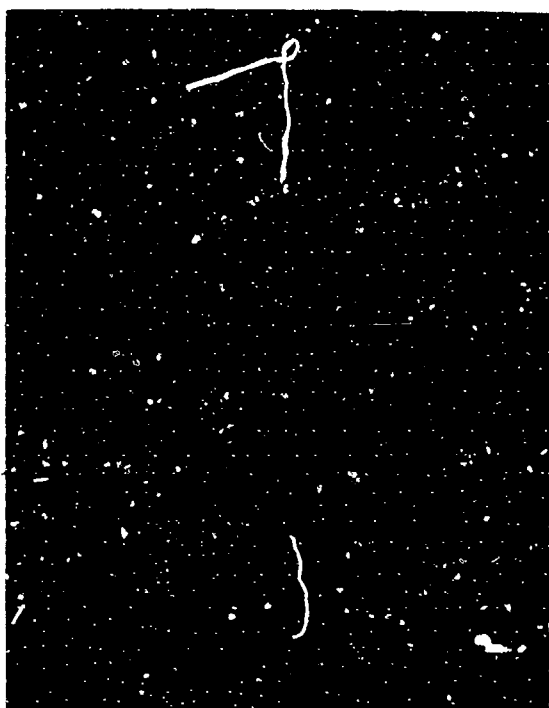

FIGURE 17. B-Scope Display of  
Top of Power Line Poles.

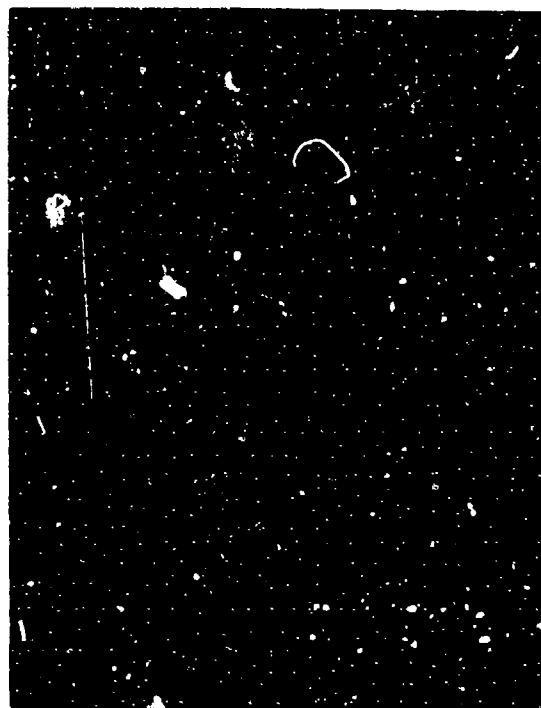

FIGURE 18. Same as Figure 17  
Except Radar Beam Lowered  
1/4 Degree.

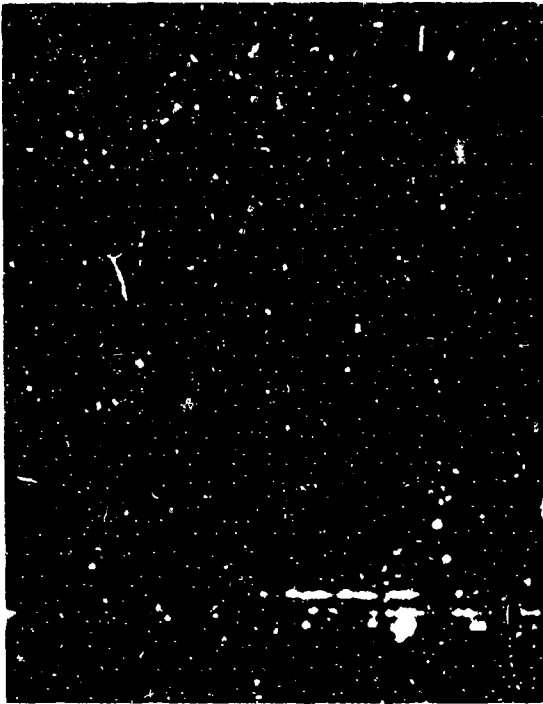

FIGURE 19. Same as Figure 17  
Except Radar Beam Lowered  
 $1/2$  Degree.



FIGURE 20. Same as Figure 17  
Except Radar Beam Lowered  
 $3/4$  Degree.

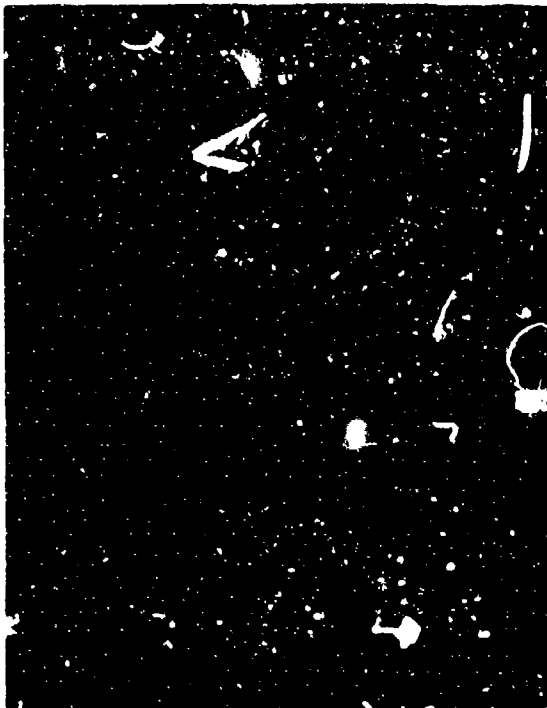

FIGURE 21. Same as Figure 17  
Except Radar Beam Lowered  
1 Degree.

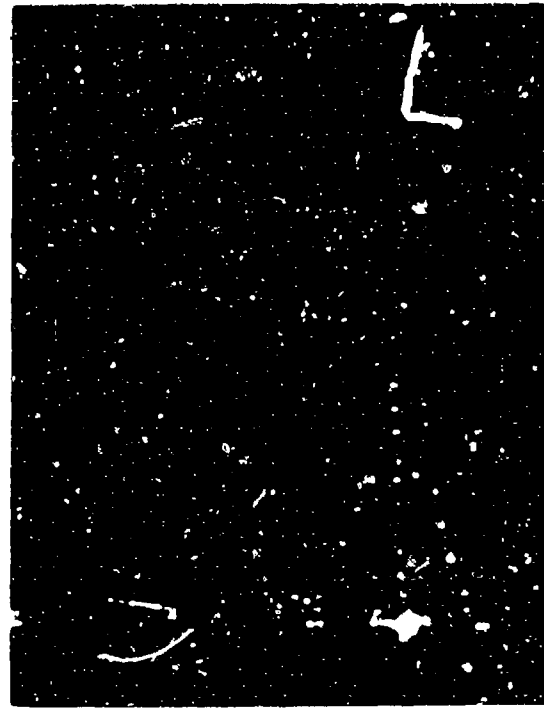

FIGURE 22. Same as Figure 17  
Except Radar Beam Lowered  
1 1/4 Degrees.

The radar was then modified (see Figure 3) to measure the relative return from various targets. No attempt was made to determine target cross sections. The radar was positioned to detect the firing of a 155-mm howitzer. Figures 23a and 23b show the position of the howitzer and the 95-GHz radar. The howitzer was fired into a dirt bank approximately 100 feet from the muzzle. The radar was positioned so that the center of its beam was 10 feet in front of the muzzle. Figure 24 shows the A-scope displays before (Figure 24a), during (Figure 24b), and after (Figure 24c) the firing of the 155-mm howitzer. The muzzle blast caused the signal level to increase, as is recorded in Figure 24d. The shell gave a large signal that could be seen on the A-scope but which was of too short a duration to be photographed with the available equipment. Because time was limited and only three rounds were available for this test, no attempt was made to improve the recording equipment.

As a result of the observation of a strong return from the power lines while the mapping radar was in operation, measurement of the relative return from a power line was also made. The radar was positioned 1/2 mile from a power line that consisted of three No. 1-0 copper stranded cables and two No. 4 solid copper wires. A 6-inch-diameter aluminum sphere was also positioned at the same range. The

return from the sphere was 28 decibels above the system noise. The return from the power lines was 35 decibels above the noise when the radar beam was pointed perpendicular to the power line. The power lines could be detected above the noise for angles out to  $\pm 30$  degrees from the normal to the lines. Table 2 lists the return signal of various targets, including the power lines.

Figure 25 is the view from the radar looking along two power lines that extend for 2 miles. Table 3 lists the return signal from the power poles as a function of range. From these tests it would seem that a millimeter wave radar may prove to be a good obstacle-avoidance radar for low-flying aircraft.

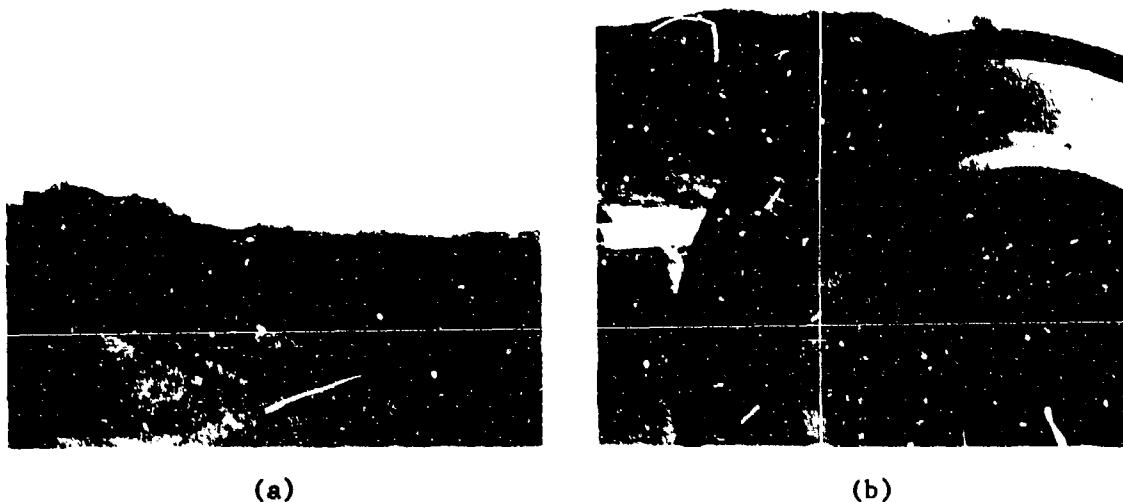
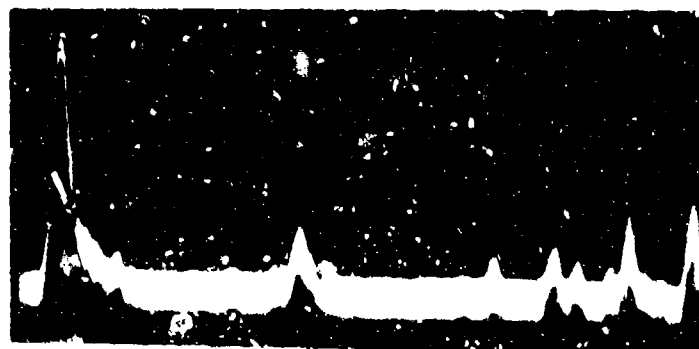
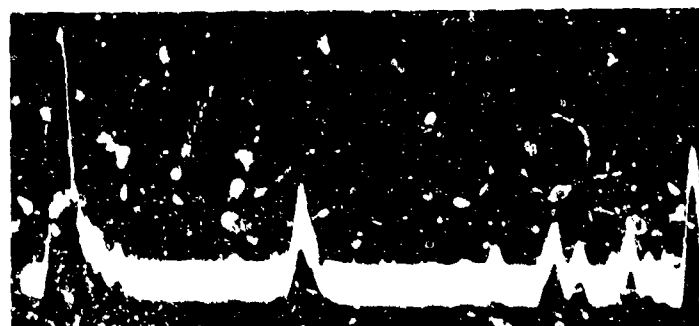

FIGURE 23. Relative Positions of 155-mm Howitzer and 95-GHz Radar. (a) Looking past the howitzer toward radar, (b) looking from radar toward howitzer.



(a)



(b)

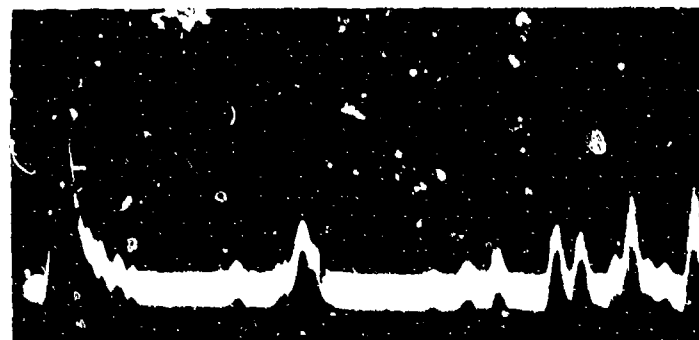

(c)

FIGURE 24. Scope Display of Radar Return From 155-mm Howitzer Tests. (a) Return before firing, (b) during firing, and (c) after firing of howitzer.

TABLE 2. Radar Signal Strength of Various Targets at Specific Ranges.

Object	Range, miles	Signal level, dB	Remarks
Power lines	1/2	35	Visible $\pm 30$ deg to normal
Al sphere 6-in.-diam.	1/2	28	...
Jeep positions:			
1	1/2	45	
2	1/2	52	
3	1/2	55	
4	1/2	44	
5	1/2	53	
B-29	1/2	>60	B-29, 6 beam widths long
Camera station	8	21	Three targets within $\sim 100$ ft of each other
Man in wet desert	1/3	50	Clutter signal $\sim 25$ dB

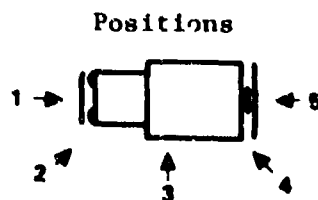

FIGURE 25. View From 95-GHz Radar Showing Two Power Lines Used for Measurements of Return From Power Line Poles.

TABLE 3. Radar Signal Strength of Power Line Pole for Ranges From 0.25 to 2 Miles.

Range, miles	Signal level above system noise, dB
0.25	57
0.40	51
0.65	55
0.80	36
1.0	35
1.25	33
1.50	30
2.0	24

#### DOPPLER RETURN DATA

During the initial phase of the millimeter Doppler radar study, the radar operation was checked by detecting moving vehicles and persons walking out to a range of 3/4 of a mile. The CW transmitter power was 3 milliwatts and the range was shadow-limited to 3/4 of a mile by buildings and trees. During the checkout procedure a building was located that gave a large Doppler signal at a range of 1/2 mile. Upon investigation the building was found to contain air conditioners and other rotating equipment. The vibrations caused by this equipment were transmitted to the outside walls of the building. Thus it is possible to determine from a distance which buildings contain rotating machinery.

In order to determine if the millimeter Doppler radar could detect when a vehicle engine is running, a jeep was parked first with its back toward the radar and then turned to face the radar. Figures 26 and 27 are frequency versus time plots of the radar output when the rear of the jeep was in the radar beam. Figure 26 was made using a low gain setting on the plotter in order to show the structure of the main vibration modes of the back of the jeep. The gain was increased for Figure 27 in order to display the spread of the spectrum about the main mode. For the first 18 seconds of the test the engine was off. The Doppler displayed during the first 12 seconds was caused by the driver rocking the jeep from the inside. The driver was still and no Doppler was produced for the interval between 12 and 18 seconds. At 18 seconds the engine was started and after several seconds the vibrations of the jeep settled down to display the vibrational modes characteristic of this vehicle at idle. The engine was allowed to idle

until, at 35 seconds, its rpm's were increased to a cruise level and held there until 53 seconds, when it was again allowed to idle. At 73 seconds the engine speed was again increased for 10 seconds and then shut off. Figure 26 shows that the resulting Doppler shifts are centered about 8 hertz. This band extends from about 2 hertz to greater than 24 hertz (see Figure 27).

The Doppler signal from the front of the jeep had a completely different character. The audio from the speaker (see Figure 3) was similar to the actual sound of the engine. Figure 28 shows Doppler frequency shift versus time (t) for data taken while the engine was started, cycled through several rpm ranges, and then shut off. The engine was started at  $t = 0$  and allowed to idle for 18 seconds, at which time the engine speed was increased and held. At  $t = 36.5$  seconds the engine was dropped back to idle. The engine speed was again increased and held for the interval between 46 to 60.5 seconds and then again allowed to idle. At  $t = 71.5$  seconds the engine was shut off. The rich Doppler spectrum from the front of the jeep is the result of the radar looking through the radiator at the fan and various other rotating parts on the engine.

The millimeter wave Doppler radar proved to be sensitive to moving targets, such as rotating antennas, bicycle wheels, men walking, and other small vibrating objects. Men walking produced a characteristic Doppler. Figure 29 is the Doppler frequency versus time of a man walking away from the radar in the radar beam. The man walked at a rate of one step every 0.5 second and produced a Doppler shift that ranged almost to 4 kilohertz with every step. A similar plot of the Doppler caused by a four-legged animal should have more structure because of the movement of the other set of legs.

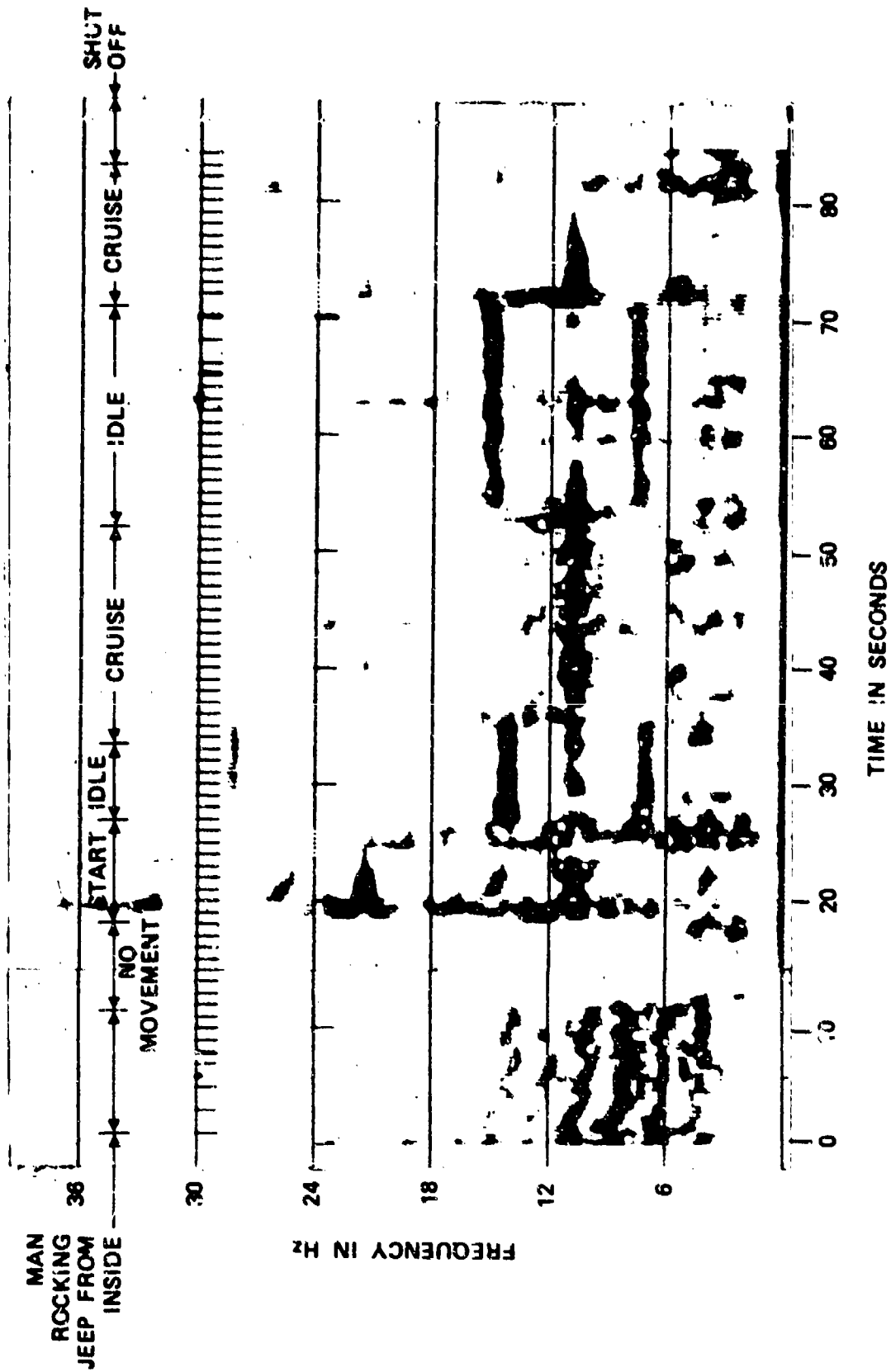

FIGURE 26. Doppler Return From Back of Jeep, Low Gain Setting on XY Recorder.

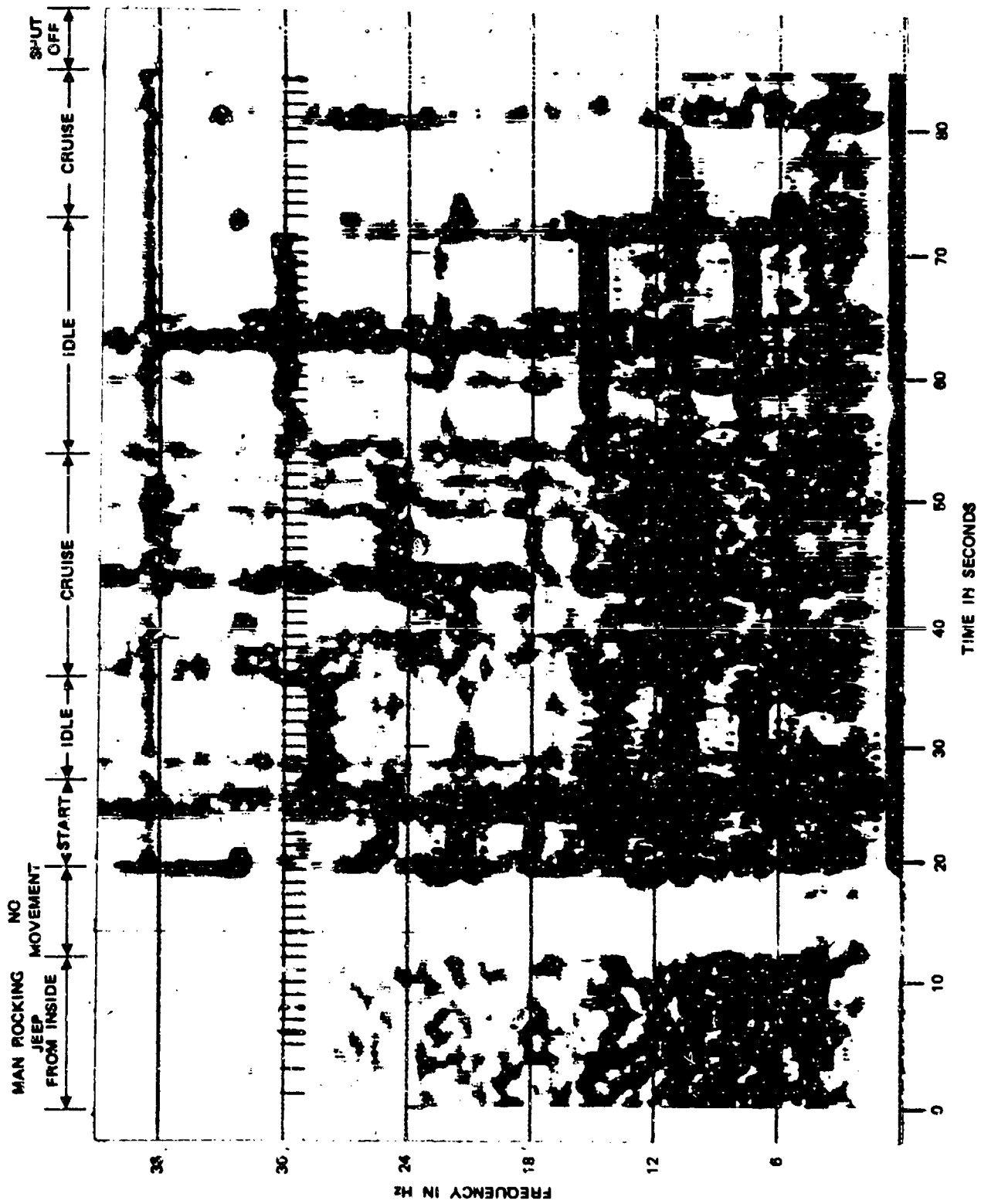

FIGURE 27. Doppler Return From Back of Jeep, High Gain Setting on XY Recorder.

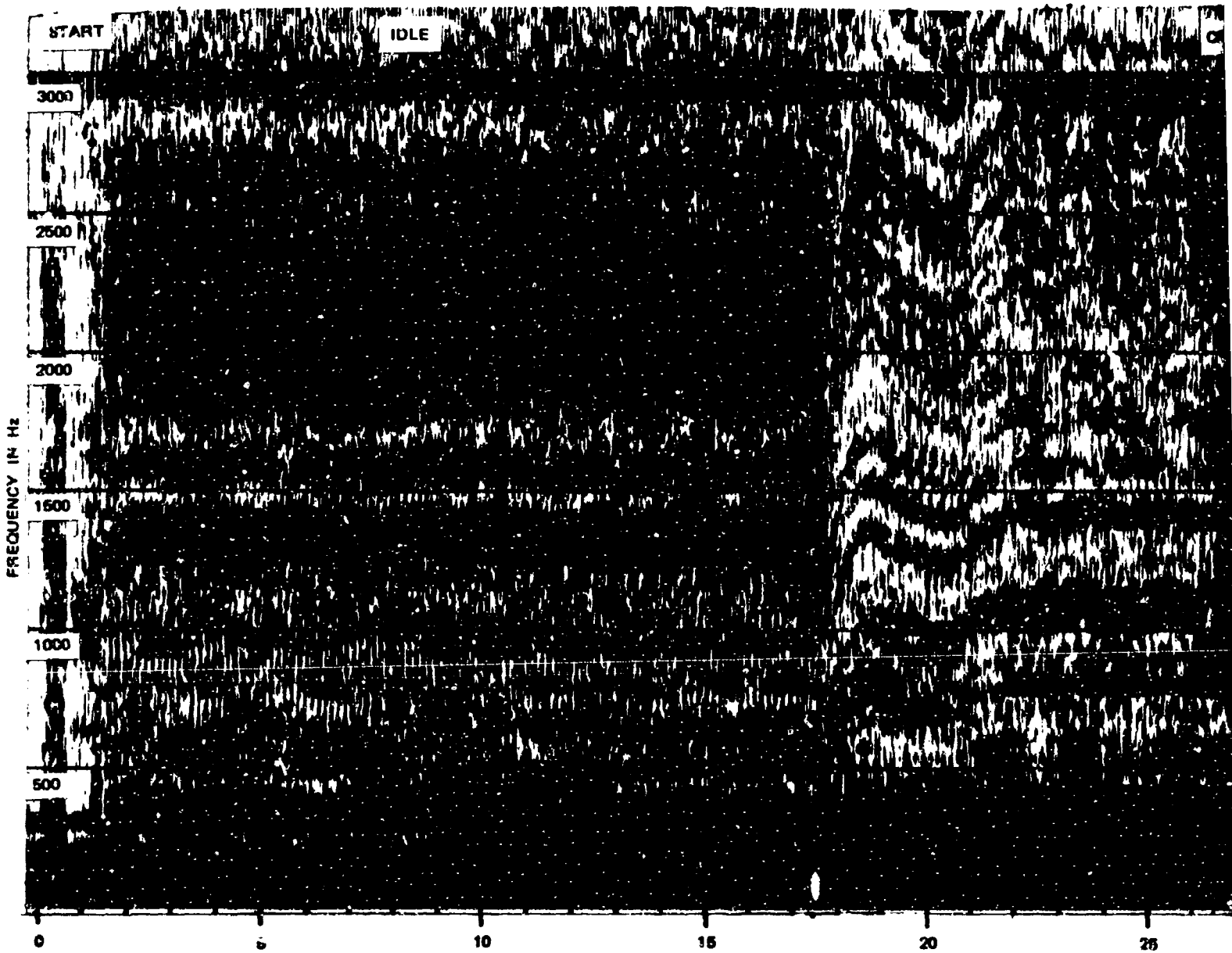

FIGURE 28. Doppler Return From Front of Jeep.

CRUISE

IDLE

20

25

30

35

40

45

TIME IN SECONDS

dep.

CRUISE

IDLE

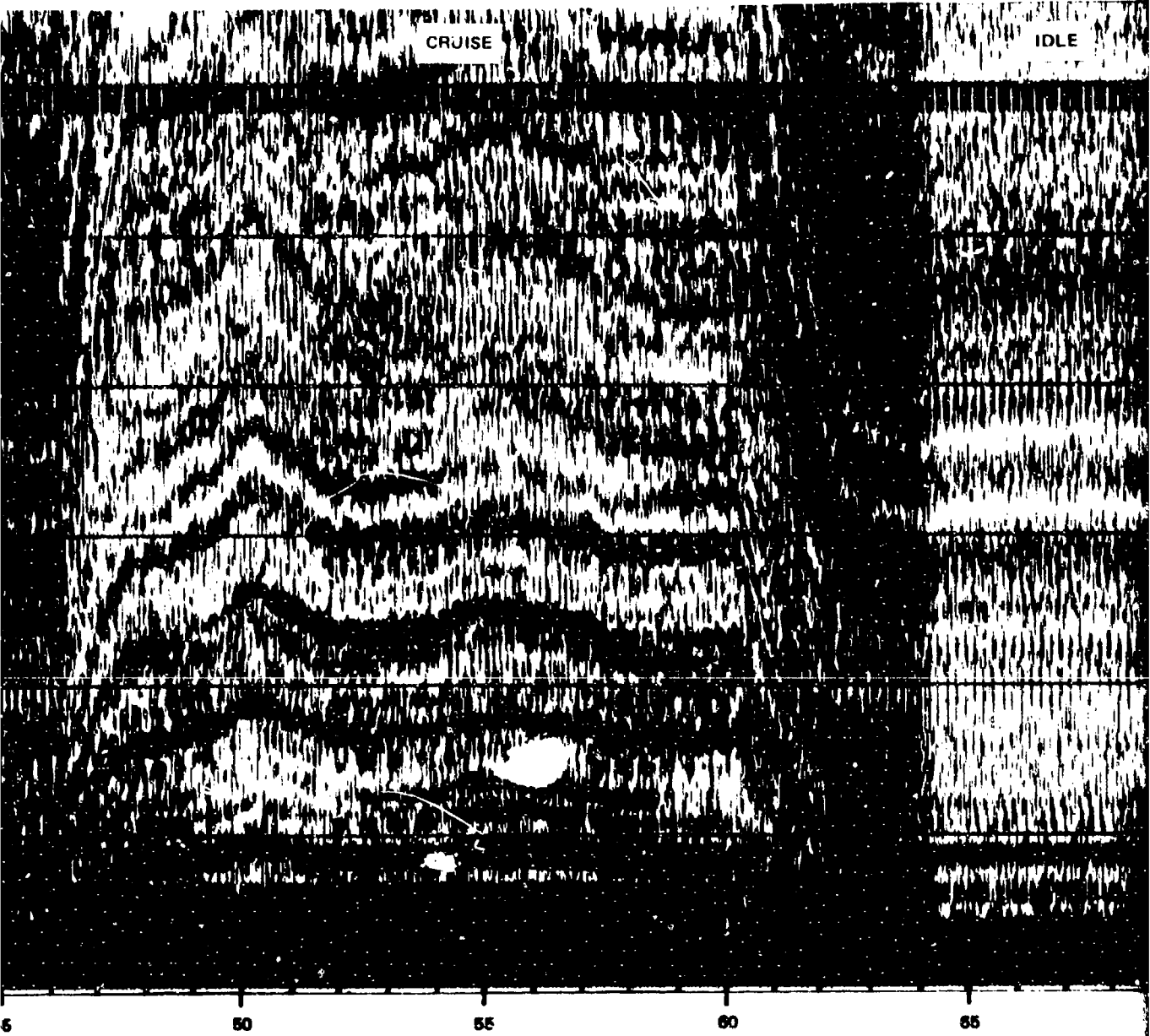

5

50

55

60

65

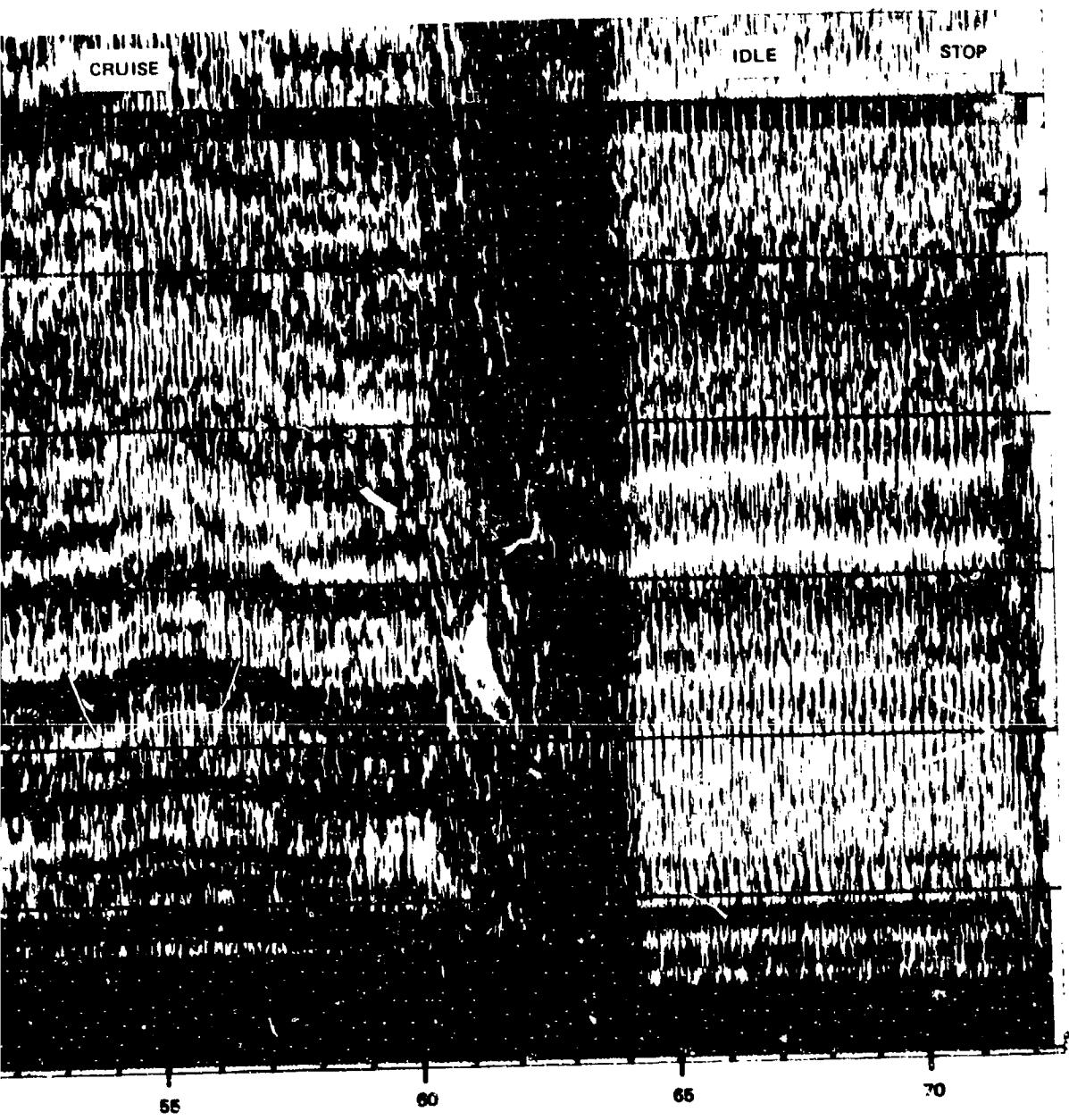

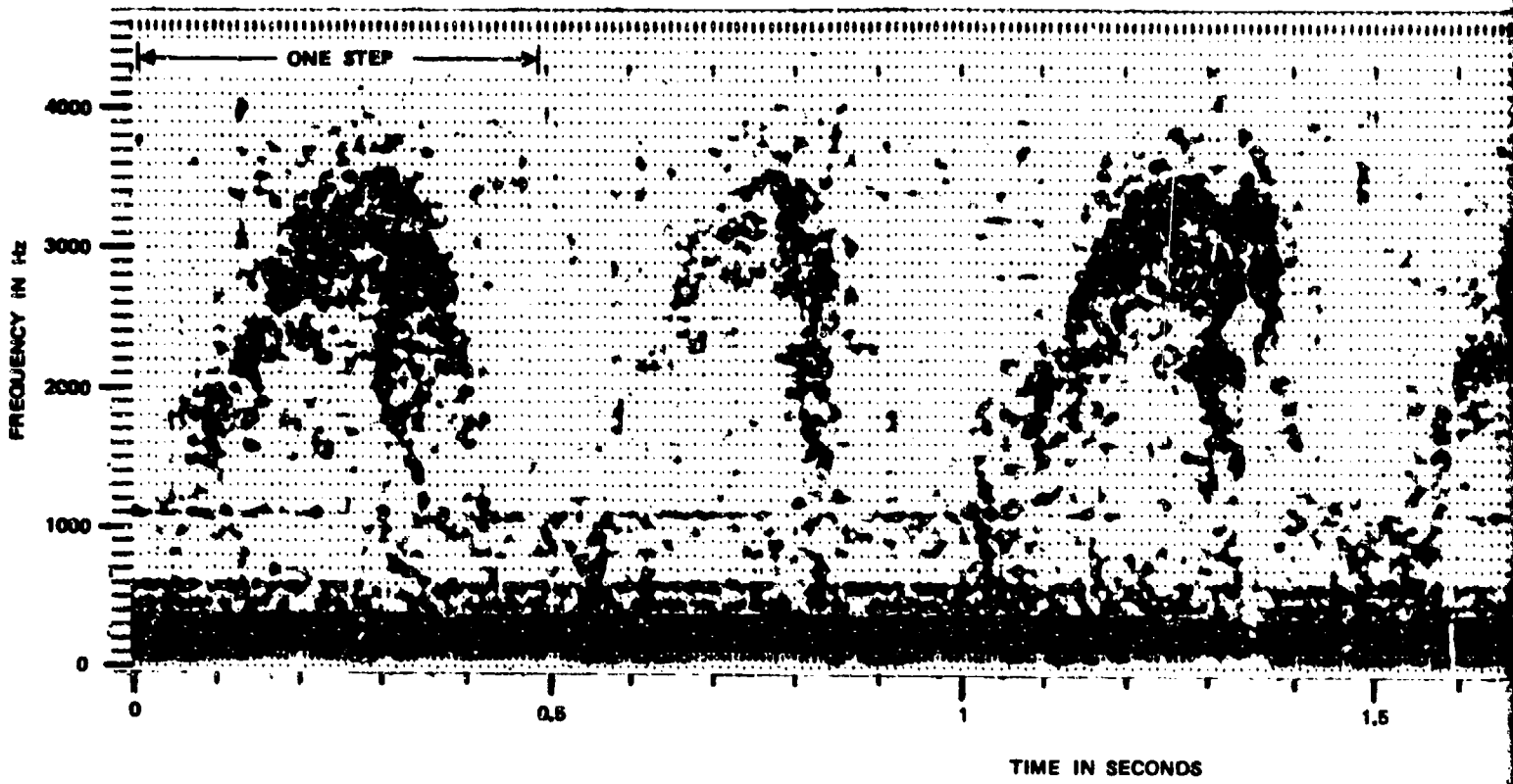
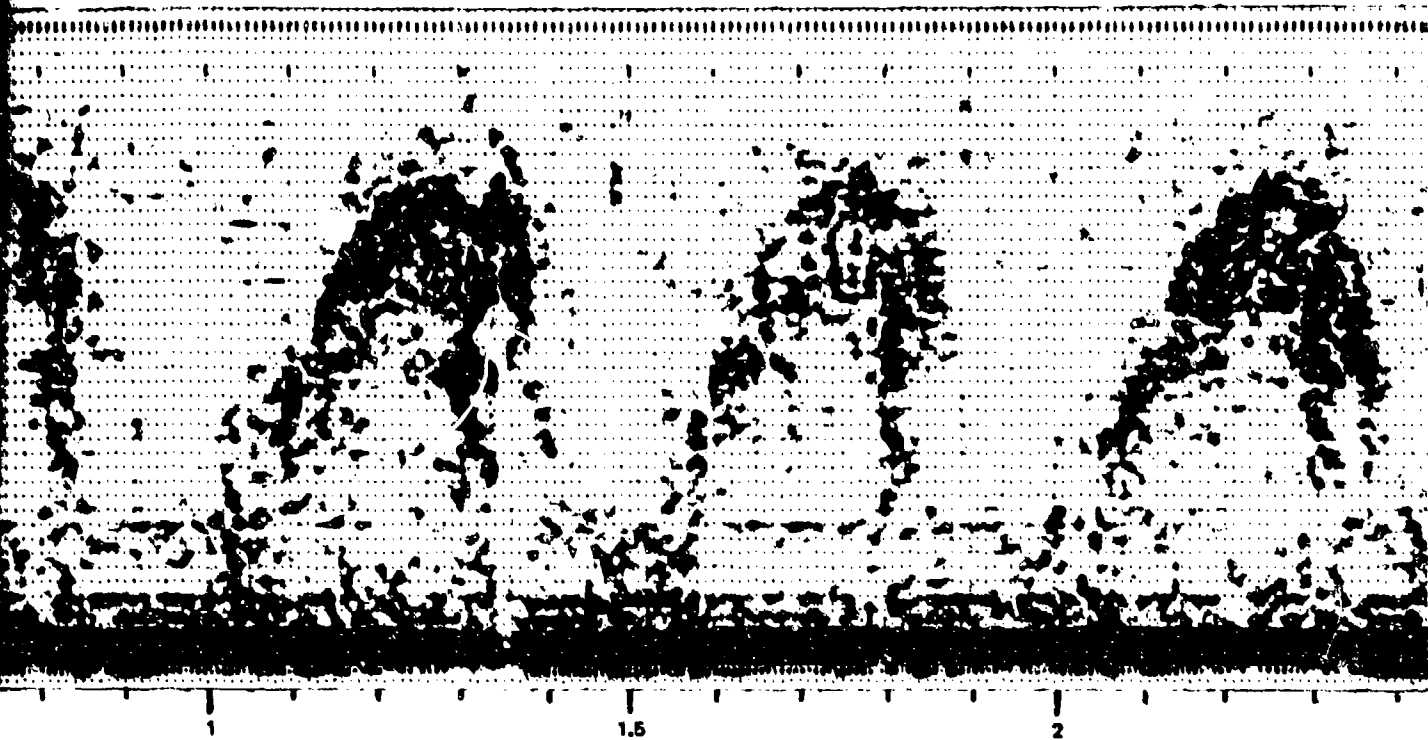

FIGURE 29. Doppler Return



TIME IN SECONDS

FIGURE 29. Doppler Return of Man Walking Parallel to Radar Beam.

NWC TP 5803

### CONCLUSIONS

A millimeter wave pulse radar will be effective in the near-ground-level environment as clutter does not seem to be as much of a problem as it does at lower frequencies. This is probably due to two effects (1) the very narrow beams that can be produced with small antennas (a 2-foot dish gives a 0.4-degree beam width at 95 GHz), and (2) clutter targets in general are more diffuse in reflecting properties at 95 GHz than at X-band. The terrain-avoidance possibilities of millimeter wave radars should be closely investigated.

The ability of the 95-GHz Doppler radar to detect vibrations and slowly moving objects has such possible applications as area security and target identification. Targets that move in the 1- to 50-mph range produce Doppler shifts that are in the audio range. Thus the operator of a pulse Doppler security radar would not need to continually monitor a display, as a simple audio alarm could be a basic part of the system. The CW Doppler return from the jeep (see Figures 26, 27, and 28) suggests that powered targets could be identified by their vibrational Doppler spectrum. More extensive millimeter wave Doppler radar studies are planned to determine the extent to which this technique can be used to identify man-made targets.