

cy 3



**MEASUREMENT OF RADIATIVE SURFACE PROPERTIES
FOR USE OF THE INFRARED SCANNING CAMERA**

**VON KÁRMÁN GAS DYNAMICS FACILITY
ARNOLD ENGINEERING DEVELOPMENT CENTER
AIR FORCE SYSTEMS COMMAND
ARNOLD AIR FORCE STATION, TENNESSEE 37389**

February 1976

Final Report for Period 1 July 1974 — 30 June 1975

Approved for public release; distribution unlimited.

Prepared for

**DIRECTORATE OF TECHNOLOGY
ARNOLD ENGINEERING DEVELOPMENT CENTER
ARNOLD AIR FORCE STATION, TENNESSEE 37389**

NOTICES

When U. S. Government drawings specifications, or other data are used for any purpose other than a definitely related Government procurement operation, the Government thereby incurs no responsibility nor any obligation whatsoever, and the fact that the Government may have formulated, furnished, or in any way supplied the said drawings, specifications, or other data, is not to be regarded by implication or otherwise, or in any manner licensing the holder or any other person or corporation, or conveying any rights or permission to manufacture, use, or sell any patented invention that may in any way be related thereto.

Qualified users may obtain copies of this report from the Defense Documentation Center.

References to named commercial products in this report are not to be considered in any sense as an endorsement of the product by the United States Air Force or the Government.

This report has been reviewed by the Information Office (OI) and is releasable to the National Technical Information Service (NTIS). At NTIS, it will be available to the general public, including foreign nations.

APPROVAL STATEMENT

This technical report has been reviewed and is approved for publication.

FOR THE COMMANDER



MARION L. LASTER
Research and Development
Division
Directorate of Technology

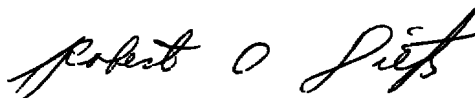

ROBERT O. DIETZ
Director of Technology

UNCLASSIFIED

REPORT DOCUMENTATION PAGE		READ INSTRUCTIONS BEFORE COMPLETING FORM
1 REPORT NUMBER AEDC-TR-76-11	2 GOVT ACCESSION NO.	3 RECIPIENT'S CATALOG NUMBER
4 TITLE (and Subtitle) MEASUREMENT OF RADIATIVE SURFACE PROPERTIES FOR USE OF THE INFRARED SCANNING CAMERA		5 TYPE OF REPORT & PERIOD COVERED Final Report, 1 July 1974 - 30 June 1975
		6 PERFORMING ORG. REPORT NUMBER
7 AUTHOR(s) J. A. Roux, ARO, Inc.		8 CONTRACT OR GRANT NUMBER(s)
9 PERFORMING ORGANIZATION NAME AND ADDRESS Arnold Engineering Development Center (DY) Air Force Systems Command Arnold Air Force Station, TN 37389		10. PROGRAM ELEMENT PROJECT, TASK AREA & WORK UNIT NUMBERS Program Element 65807F
11 CONTROLLING OFFICE NAME AND ADDRESS Arnold Engineering Development Center (DYFS), Air Force Systems Command, Arnold Air Force Station, TN 37389		12. REPORT DATE February 1976
		13 NUMBER OF PAGES 24
14 MONITORING AGENCY NAME & ADDRESS (if different from Controlling Office)		15 SECURITY CLASS (of this report) UNCLASSIFIED
		15a DECLASSIFICATION/DOWNGRADING SCHEDULE N/A
16 DISTRIBUTION STATEMENT (of this Report) Approved for public release; distribution unlimited.		
17 DISTRIBUTION STATEMENT (of the abstract entered in Block 20, if different from Report)		
18 SUPPLEMENTARY NOTES Available in DDC.		
19 KEY WORDS (Continue on reverse side if necessary and identify by block number) reflectometers surface properties infrared scanner temperature		
20 ABSTRACT (Continue on reverse side if necessary and identify by block number) An integrating sphere reflectometer was assembled for the measurement of radiative properties of surfaces on which temperature may be determined with the infrared scanning camera. The spectral-directional emittance was determined in the wavelength range of $1.3 \mu\text{m} \leq \lambda \leq 5.5 \mu\text{m}$; the view angle was varied from near normal to 30 deg; the temperature range of interest was ambient to 500°F. Also, for calibration purposes, a large-aperture blackbody		

UNCLASSIFIED

20. ABSTRACT (Continued)

calibration source was designed to operate at temperatures below 250°F.

PREFACE

The work reported herein was conducted by the Arnold Engineering Development Center (AEDC), Air Force Systems Command (AFSC), under Program Element 65807F. The results of the research were obtained by ARO, Inc. (a subsidiary of Sverdrup & Parcel and Associates, Inc.), contract operator of AEDC, AFSC, Arnold Air Force Station, Tennessee, under ARO Project Number V35S-62A. The author of this report was J. A. Roux, ARO, Inc. The manuscript (ARO Control No. ARO-VKF-TR-75-91) was submitted for publication on June 24, 1975.

CONTENTS

	<u>Page</u>
1.0 INTRODUCTION	5
2.0 TECHNIQUE OF DETERMINING SPECTRAL-DIRECTIONAL EMITTANCE.	6
3.0 APPARATUS.	7
4.0 RESULTS	16
5.0 SUMMARY AND CONCLUSIONS	23
REFERENCES	24

ILLUSTRATIONS

Figure

1. Schematic of Infrared Integrating Sphere and Components	7
2. 8-in. Integrating Sphere with Optical System	8
3. Sample Holder Assembly	9
4. Model 98 Wavelength Calibration for CaF ₂ Prism	10
5. Detectivity of a Typical InSb Detector.	11
6. Blackbody Calibration Source	12
7. IR Camera Spatial Resolution for 10-, 25-, and 45-deg Field of View Lenses (From Ref. 4)	14
8. Apparent Emittance Results for Diffusely, Specularly, and Specularly-Diffusely Reflecting Conical Cavities (From Ref. 2)	15
9. Apparatus for Blackbody Radiation Distribution Measurements	15
10. Directional Emittance of Lexan	16
11. Directional Emittance of RTV-60 as a Function of Wavelength and Temperature	18

<u>Figure</u>	<u>Page</u>
12. Directional Emittance of RTV-732 as a Function of Wavelength and Temperature	19
13. Directional Emittance of Rust-Oleum® 4279 Black Paint as a Function of Wavelength and Temperature . .	20
14. Hemispherical-Directional Reflectance of High α Copper Black	21
15. Hemispherical-Directional Reflectance of Low α Copper Black	21
16. Calibration Blackbody-Emitted Radiation Distribution for a Source Temperature of 120°F	22
17. Calibration Blackbody-Emitted Radiation Distribution for a Source Temperature of 210°F	23

1.0 INTRODUCTION

Recently an infrared (IR) scanning camera was purchased for use at AEDC. The camera can be used for mapping the temperature distribution of test articles in space simulation chambers and also for aerodynamic heating on wind tunnel models. For aeroheating applications, the camera is used to measure the transient temperature distribution on a model; from these measurements the distribution of the heat-transfer coefficient is determined. Another potential application for the IR scanning camera is for use in measuring plume radiance (radiant flux) from rocket engines fired in the space simulation chambers.

Since the IR scanning camera measures radiant flux, it is necessary to infer temperature measurements from flux measurements. For obtaining surface temperatures it is necessary to know the emissivity of the surface. Hence an integrating sphere reflectometer was assembled for measuring the spectral-directional emittance. Because the IR scanning camera is equipped with an indium antimonide (InSb) detector (which operates in the 2- to 5- μm wavelength band), the spectral range from 1.3 to 5.5 μm was covered in the spectral measurements. The angular range of interest was from near normal to 30-deg view angle. Also, the temperature range covered was from ambient to 500°F, since 500°F is about the maximum model temperature encountered in wind tunnels where the IR camera may be used.

For the purpose of measuring the radiant flux from a body or an exhaust plume it is necessary to calibrate the IR camera against a blackbody source. Also, it is necessary to have a calibration blackbody in order to determine the temperature of nonblackbody opaque surfaces. The requirements for the blackbody calibration source are that it can be used under vacuum conditions and that it have a large aperture such that the calibration source can be used at large distances without being limited by the spatial resolution of the IR camera. This is especially true for IR camera use in the large vacuum chambers where the camera is located at considerable distances away from the test object.

With a vacuum-rated calibration source the IR camera can be calibrated for the same location as the test article, and also the calibration can eliminate the effects of any window (transmittances or mirror reflections). Because most thermal vacuum tests involve temperatures below 250°F, the calibration blackbody was designed to operate at temperatures of 250°F and below.

2.0 TECHNIQUE OF DETERMINING SPECTRAL-DIRECTIONAL EMITTANCE

The absolute, spectral directional emittance of various surfaces was obtained by measuring the hemispherical-directional reflectance and applying the conservation of energy principle for an opaque, surface, namely

$$\epsilon_d = 1 - \rho_{hd} \quad (1)$$

The hemispherical-directional reflectance is defined (Refs. 1 and 2) as

$$\rho_{hd} = \frac{I_r(\psi, \lambda)}{e_{i,h}(\lambda)/\pi} = \frac{I_r(\psi, \lambda)}{I_i(\lambda)} \quad (2)$$

where $I_r(\psi, \lambda)$ is the reflected intensity for a small collection solid angle Δw_r (0.02 steradians) which is inclined at the angle ψ , and $e_{i,h}(\lambda)$ is the hemispherically incident radiant energy. Associated with $e_{i,h}(\lambda)$ is the diffuse incident intensity $I_i(\lambda)$. In all cases, λ indicates the particular monochromatic wavelength of the measurement. In this work the same solid angle was used for measuring both $I_r(\psi, \lambda)$ and $I_i(\lambda)$ so that the absolute hemispherical-directional reflectance can be found from the right-hand side of Eq. (2). In order to determine the absolute hemispherical-directional reflectance (and hence directional emittance) of a sample at a given wavelength using Eq. (2), it was necessary to measure a signal proportional to $I_r(\psi, \lambda)$ and $I_i(\lambda)$ and then ratio the two according to Eq. (2). These measurements were obtained (also see Ref. 1) by viewing the sample at a given wavelength and obtaining a detector output $D_r(\lambda)$, which was proportional to $I_r(\psi, \lambda)$, $D_r = c I_r(\psi, \lambda)$. A portion of the sphere wall which was not directly irradiated by the source was then viewed under the same conditions of Δw_r and λ ; a detector output, D_i , was thereby obtained which was proportional to $I_i(\lambda)$, $D_i = c I_i(\lambda)$. The proportionality constant, c , depends only on the viewing optics and detection system and is the same in both cases. Further, since the sphere wall was perfectly diffuse, it was uniformly irradiated by multiple reflections. The intensity of the radiation reflected from the sphere wall is then equal to the intensity which is incident on the test surface. The absolute reflectance was determined by ratioing the two detector outputs, since

$$\frac{D_r}{D_i} = \frac{c I_r(\psi, \lambda)}{c I_i(\lambda)} = \rho_{hd} \quad (3)$$

It should be stressed that the reflectances (and hence directional emittances) obtained with this technique are absolute. The reflectance is measured directly and is not referenced to a standard reflector. Employing these principles made it possible to obtain the absolute directional emittances of the samples [via Eqs. (3) and (1)].

3.0 APPARATUS

The integrating sphere (see Figs. 1 and 2) used in this study consisted of two stainless steel hemispheres 8 in. in diameter and a centrally located sample holder. As was noted above, it was important that the interior of the sphere be a diffuse reflector. This was accomplished by coating the interior of the sphere with a thick (greater than 3 mm) coat of powdered sodium chloride (NaCl); the NaCl was pressed onto a thin film of low vapor pressure vacuum grease.

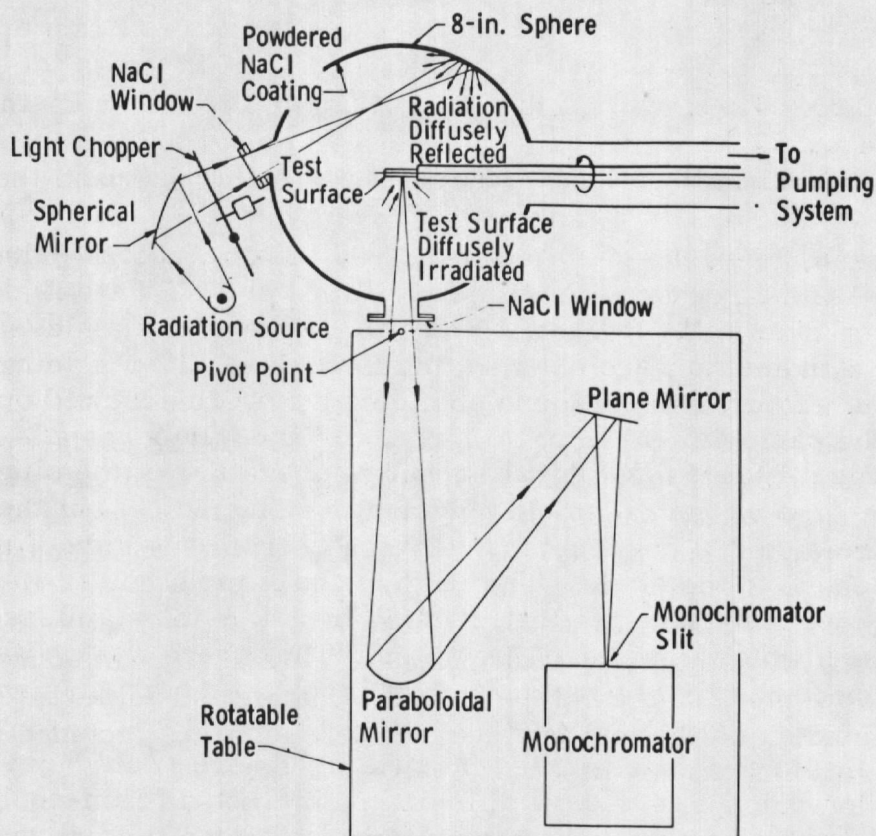

Figure 1. Schematic of infrared integrating sphere and components.

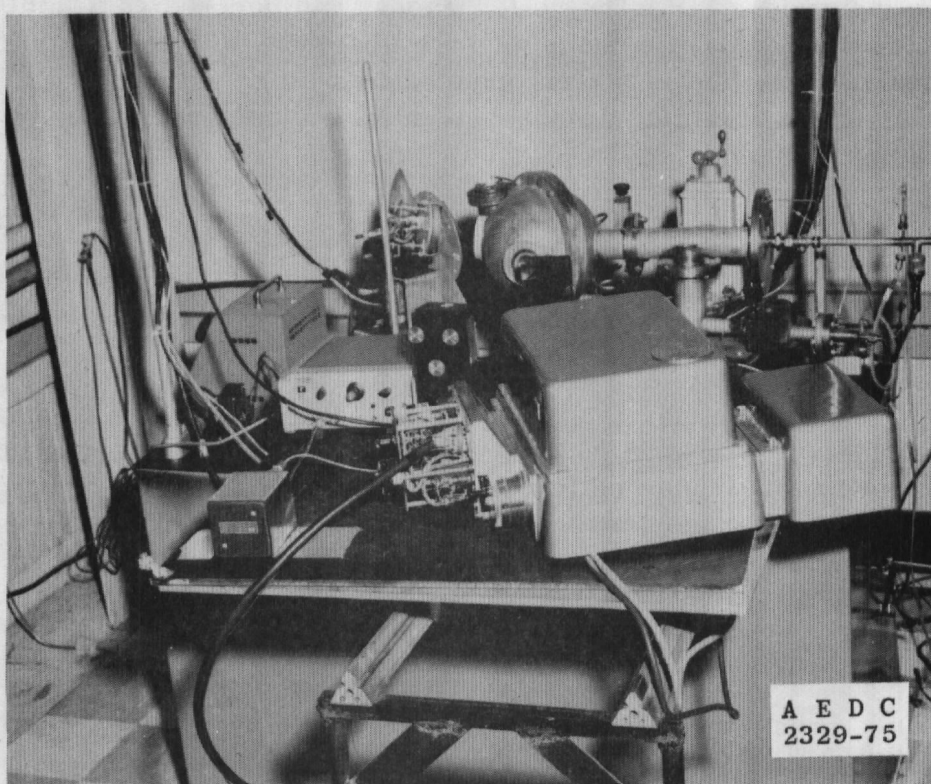

Figure 2. 8-in. integrating sphere with optical system.

The samples were of a standard size, the dimensions being 1 by 1-1/2 in. The directional emittance of paints and RTV's was determined by applying them to a 1 by 1-1/2 by 3/16-in. piece of stainless steel equipped with a copper-constantan thermocouple (silver soldered) for temperature monitoring. These sample slugs were screwed onto a flat plate of the same dimensions; to the rear of this plate was silver soldered the electrical heater for controlling the temperature of the slugs. The stem (see Fig. 3) of the sample holder was designed so that the sample could be rotated 360 deg and moved laterally from one side of the integrating sphere to the other. The stem of the sample holder was thermally isolated from the (hot) sample by a 1/8-in. stainless steel tube through which flowed cooling water. Thus there was no danger of the stem becoming hot or any danger of injury to the experimenter.

The inside of the assembled integrating sphere could be evacuated using an ion pump, a 4-in. oil diffusion pump with a freon-cooled trap, and a mechanical pump. Chamber pressures inside the integrating sphere were measured using an ion gage and a thermocouple gage; typical chamber pressure during tests was 4×10^{-5} torr.

Light from a 1,000-w tungsten-iodide bulb was chopped at 13 Hz and then focused through a 3-in. -diam NaCl window onto a portion of the back wall inside the integrating sphere. The light was then reflected diffusely throughout the sphere by the wall coating and was hemispherically incident on the sample surface with a diffuse distribution. The radiation passed through a NaCl window on the front viewport and was collected by an off-axis paraboloidal mirror after it was reflected either from a portion of a sphere wall which was not directly irradiated, or from the sample surface. Then, this same off-axis paraboloidal mirror, along with a folding mirror, focused the radiation on the entrance slit of a Perkin Elmer Model 98 monochromator. The monochromator, paraboloidal mirror, and folding mirror were mounted on a table top which could be rotated about the vertical centerline of the viewport, allowing the collection of the radiation from either the test surface or the sphere wall.

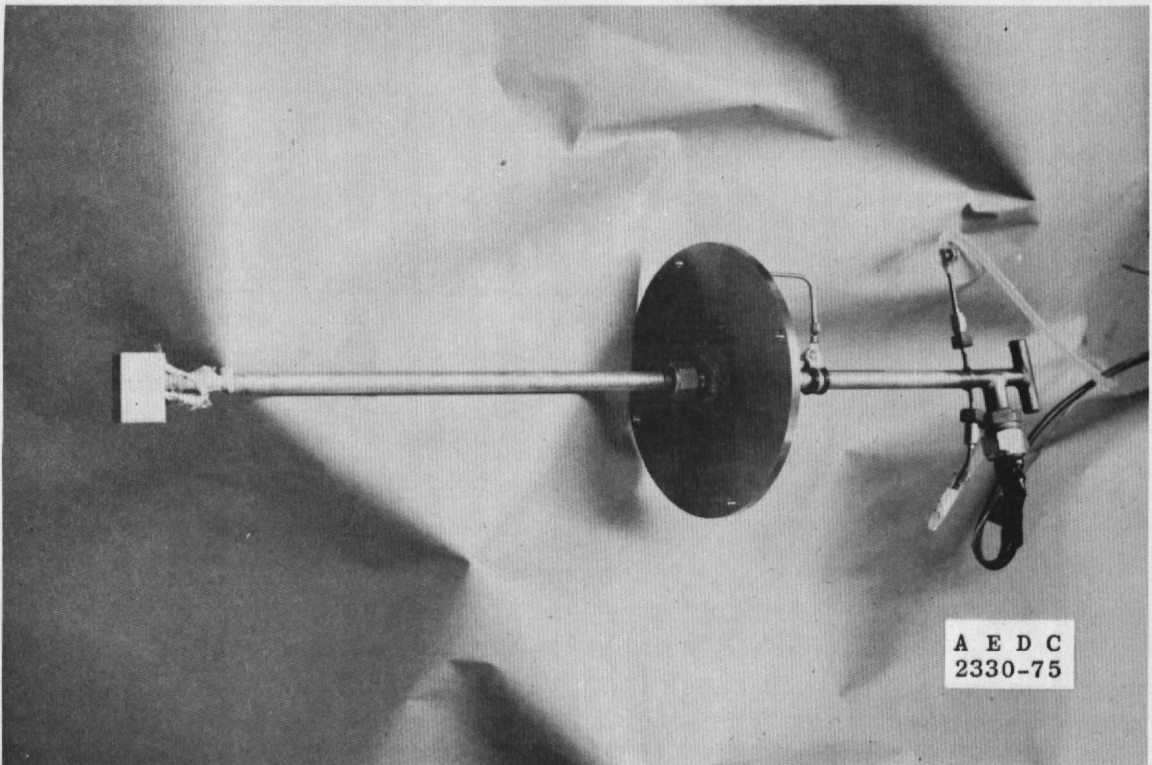

Figure 3. Sample holder assembly.

The Model 98 monochromator is used with a calcium fluoride (CaF_2) prism and is a single-pass instrument. The wavelength versus drum number calibration is shown in Fig. 4. After the radiation passed through the monochromator where the wavelength of interest was selected, it was detected by a Reedeer thermocouple (RP-5W) detector. The signal from the detector was then amplified through a Princeton Applied Research (PAR) Model AM-1 transformer,

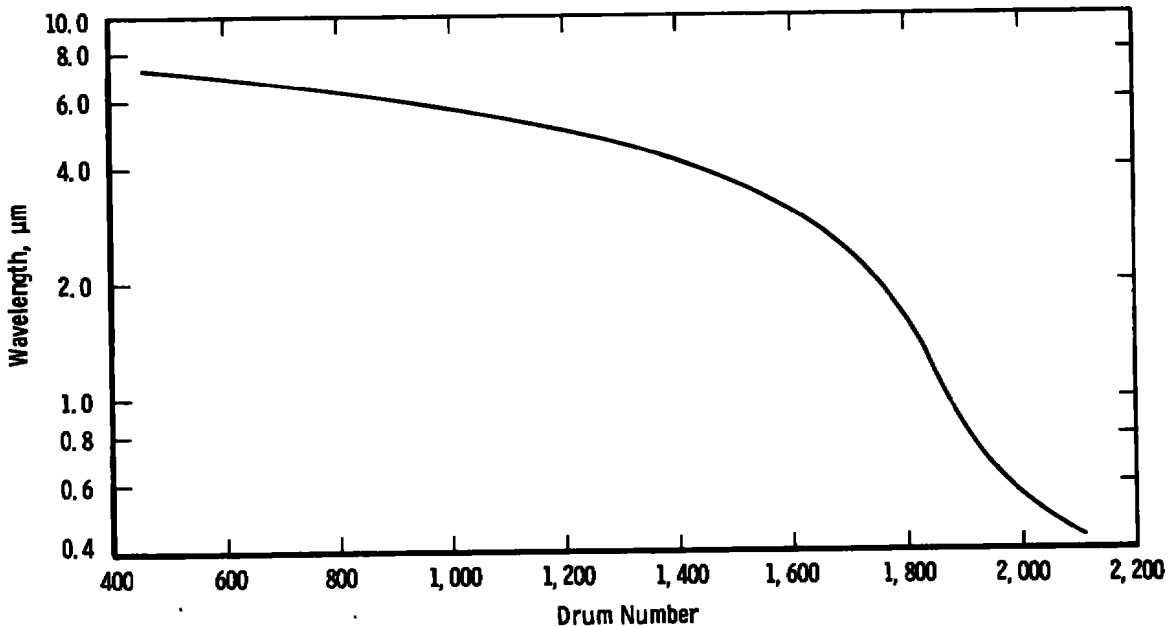

Figure 4. Model 98 wavelength calibration for CaF_2 prism.

a PAR 113 preamplifier, and then through a PAR 120 lock-in amplifier; the signal was displayed on a strip chart recorder. This system allowed the directional emittance of a sample to be determined spectrally in the wavelength range from 0.50 to 5.50 μm . For IR camera purposes the wavelength region of primary interest is from 2 to 5 μm since the camera is equipped with an InSb detector. (See Fig. 5 for typical InSb D^* performance.)

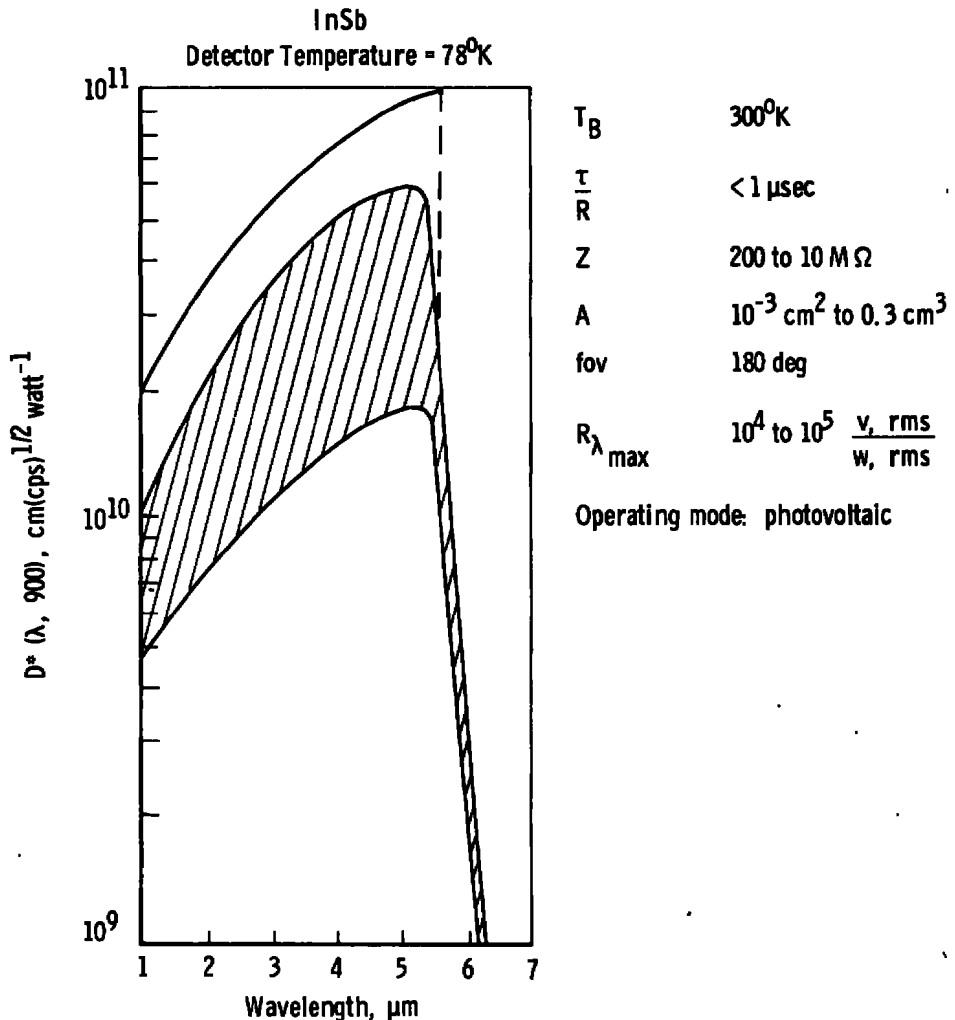
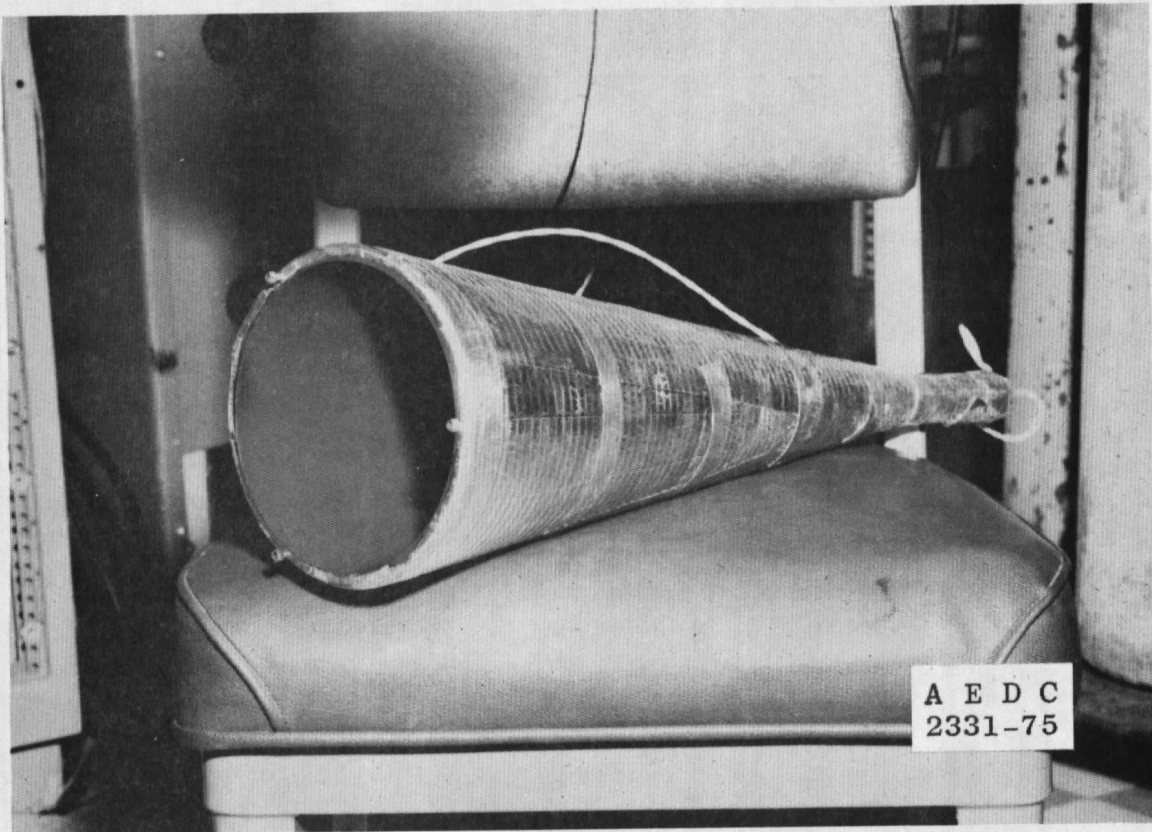
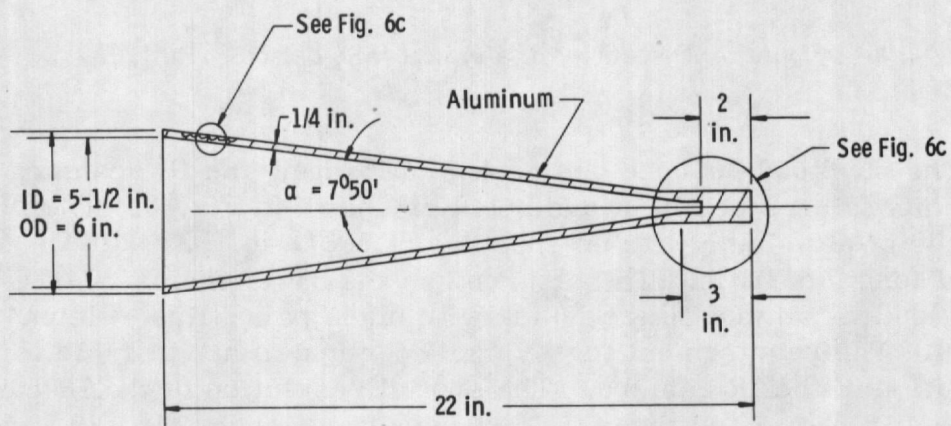

Figure 5. Detectivity of a typical InSb detector (Ref. 3).

The blackbody source design for calibrating the IR scanning camera for temperatures of 250° F and below is shown in Fig. 6. The blackbody is made of aluminum with an aperture of 5-1/2 in. ID and 6 in. OD and a total length of 22 in. This source has the basic geometry of a conical cavity and is painted on the inside with black paint (Rust-Oleum® 4279 Black). The requirement for a large aperture is attributable to the spatial resolution of the IR camera. The spatial resolution of the IR camera is depicted in Fig. 7 for three field of view (fov) lenses (10, 25, and 45 deg). The spatial resolution is the smallest angle (measured in 10^{-3} radians) for which the curve in Fig. 7 is still flat; i. e., for the 10-deg fov lens



a. Photograph of calibration blackbody



b. Design sketch of large-aperture calibration blackbody
Figure 6. Blackbody calibration source.

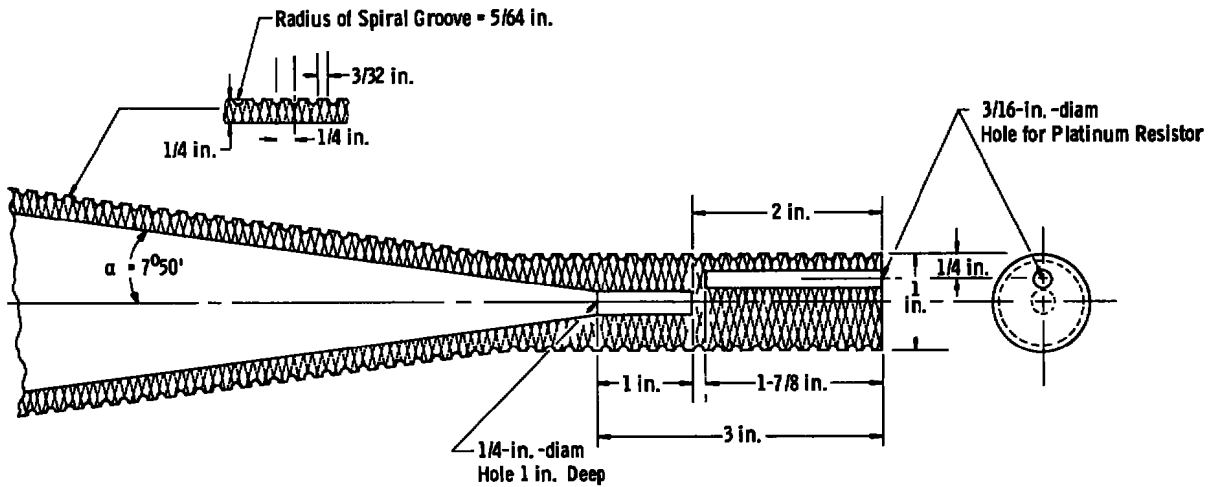

c. Groove pattern and platinum resistor location of blackbody calibration source
Figure 6. Concluded.

the spatial resolution is about 4 mrad, for the 25-deg fov lens the spatial resolution is about 9 mrad, and for the 45-deg fov lens the spatial resolution is about 15 mrad. For example, if the camera were used with the 25-deg fov lens at a distance of 30 ft, then

$$S = R\theta \quad (4)$$

and

$$S = 30 \times 12 \text{ in.} \times 9 \times 10^{-3} \text{ rad} = 3.24 \text{ in.} \quad (5)$$

Thus, the uniform core of the blackbody required would be 3.24 in. This is the reason for designing such a large-aperture blackbody.

The exterior of the blackbody was grooved in the form of a tapered helix; the grooves were made 5/64-in. deep. Into the grooves the heater wire for controlling the temperature of the blackbody was tightly wrapped; the temperature of the blackbody was monitored via a platinum resistor mounted at the narrow end of the blackbody (see Fig. 6c). The length to radius ratio of the conical cavity is

$$L/R = 20.0/2.75 = 7.28 \quad (6)$$

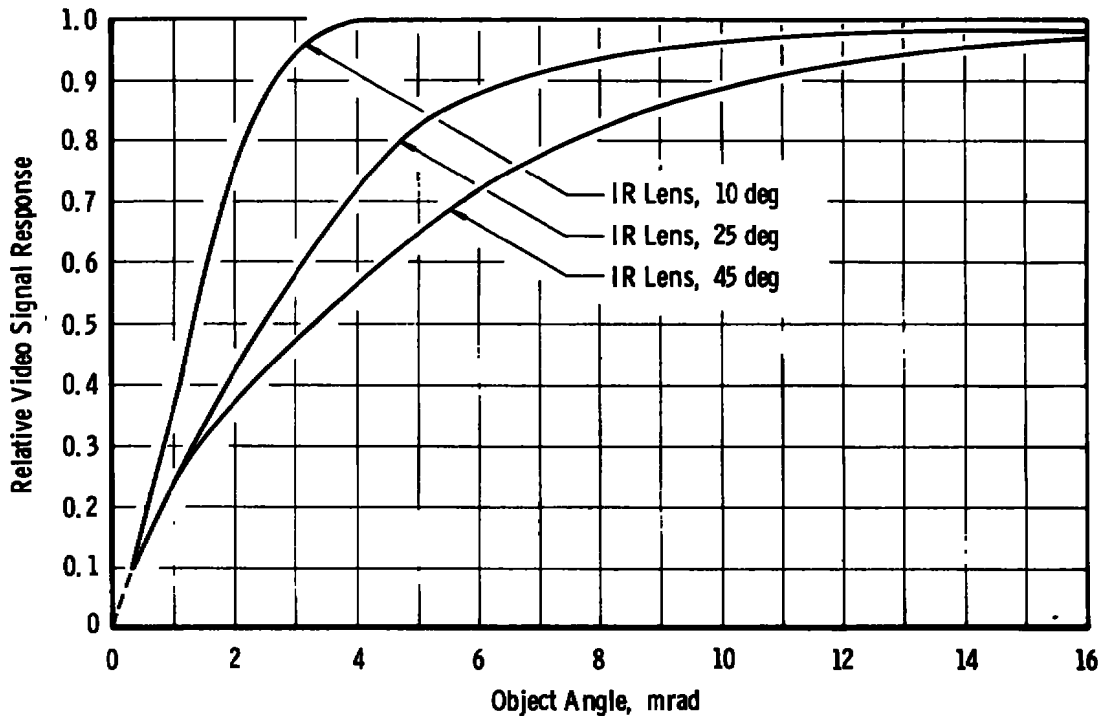

Figure 7. IR camera spatial resolution for 10-, 25-, and 45-deg field of view lenses (from Ref. 4).

and the emissivity of the black paint used to coat the blackbody is about 0.94, flat over the spectral range of interest (2 to 5 μm). From the curves shown in Ref. 5 this would yield an effective blackbody emissivity of 0.999. Also from Fig. 8, taken from Ref. 2, it can be seen that the blackbody has a very high emissivity; the cone angle 2ϕ corresponding to Fig. 8 is about 16 deg, and the black paint is specular with an emissivity greater than the 0.90 curve shown in Fig. 8.

The apparatus used to measure the blackbody radiation uniformity across the aperture is shown in Fig. 9. An off-axis paraboloidal mirror was used to collect radiation from the blackbody exit aperture and to focus the radiation (chopped at 13 Hz) on a pyroelectric detector. The detector was scanned across the diameter of the calibration blackbody to determine its uniformity and thus to determine at what distances the blackbody could be used without violating the spatial resolution of the IR camera. The blackbody along with the IR camera has been used on a thermal vacuum test during FY75, and the blackbody is also being used to calibrate the IR camera for aeroheating tests.

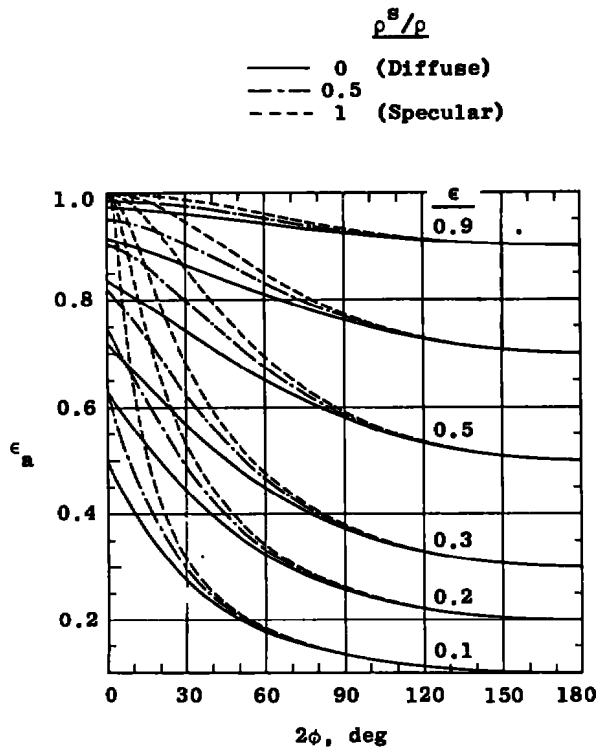

Figure 8. Apparent emittance results for diffusely, specularly, and specularly-diffusely reflecting conical cavities (from Ref. 2).

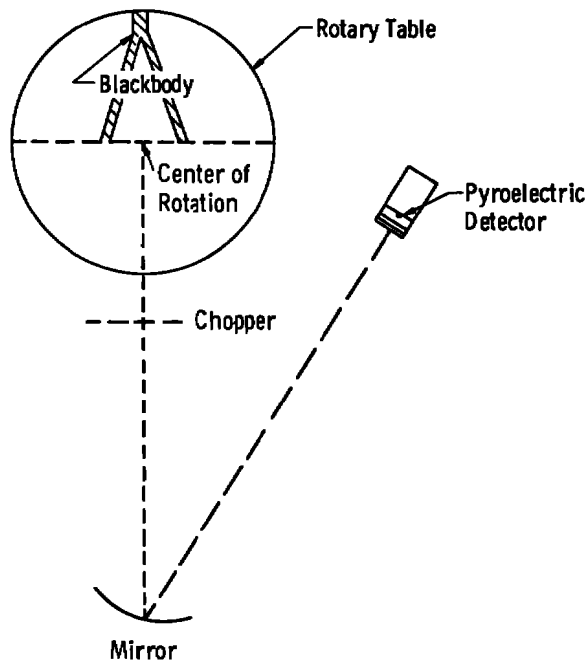
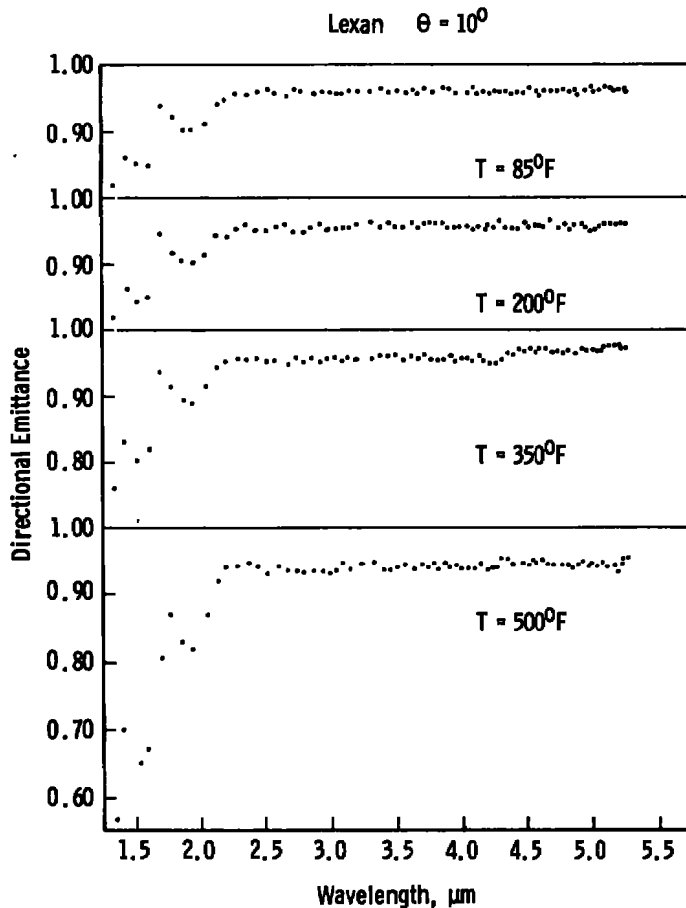

Figure 9. Apparatus for blackbody radiation distribution measurements.

4.0 RESULTS

For IR camera applications associated with the AEDC Hypervelocity Tunnel (F) it is important to know the emittance of lexan. Figure 10a shows the directional emittance of lexan near normal incidence in the wavelength range from 1.3 to 5.25 μm for temperatures from 85 to 500°F. The emittance of lexan is seen to be very high (≈ 0.96) and is spectrally flat (2 to 5 μm). For IR camera applications these are very desirable properties. Also, the emittance is essentially independent of temperature, with the emittance only about 0.02 lower at 500°F. This is because at 500°F lexan is very near to its melting emperature, which is slightly above 500°F. At short wavelengths (1.5 μm) the emittance is seen to decrease with temperature; however, this is of no consequence since this is below the useful wavelength range of the IR camera. It is a desirable property to know that the emittance of lexan is constant with wavelength



a. Directional emittance of Lexan as a function of wavelength and temperature
 Figure 10. Directional emittance of Lexan.

and temperature, but it is also important to know if the emissivity will change after being exposed to the flow. This is particularly true for Tunnel F applications where dust particles in the flow field can become imbedded in the lexan and change the emittance for subsequent tunnel shots. The results in Fig. 10b show that although the lexan becomes visibly dirty after a Tunnel F firing there is only a slight (negligible) decrease in the surface emittance. This again is a very desirable property and important to know in determining temperatures from Tunnel F lexan models.

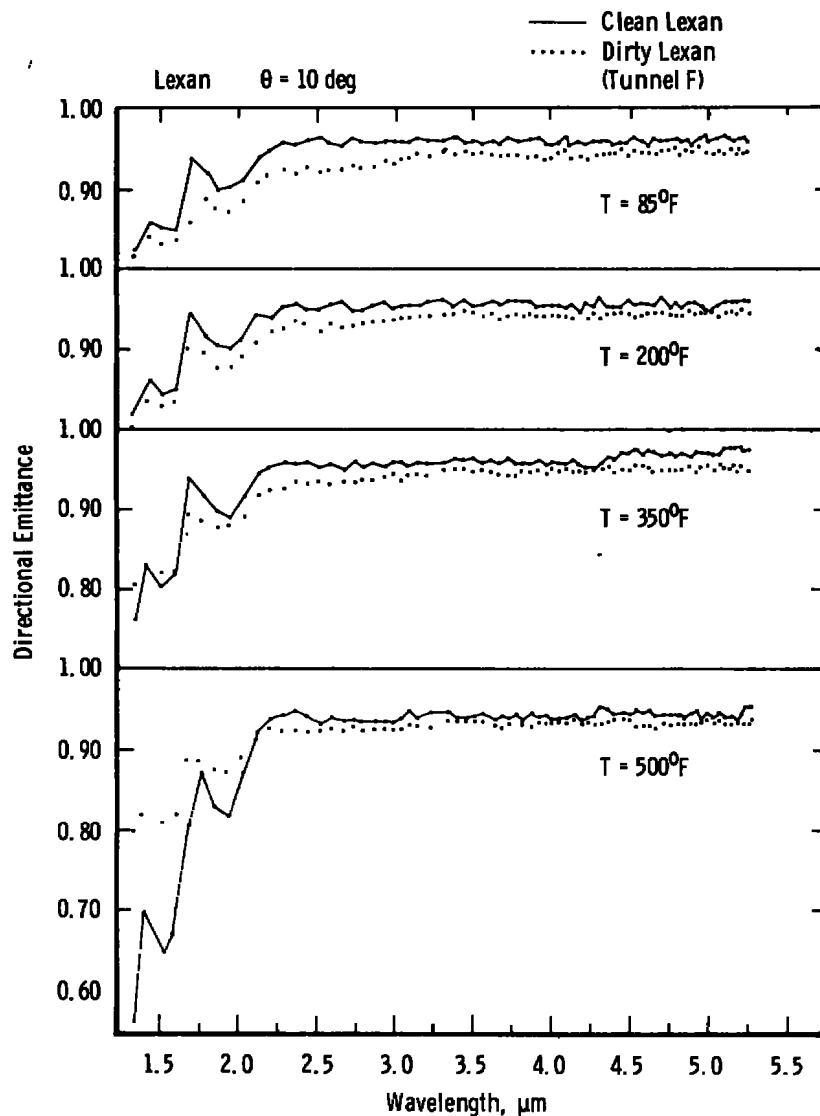

b. Comparison of directional emittance of Lexan before and after being subjected to Tunnel F flow field

Figure 10. Concluded.

Figure 11 shows the directional emittance of RTV-60, which was also being considered as a surface coating for aeroheating applications. This appears to be an undesirable material for IR camera temperature measurement since the emittance is not spectrally flat. Also, the emittance is essentially independent of temperature from 81 to 350°F, but at 500°F there is a slight change in the emittance at about 2.75 μm . This material (RTV-60) may still be used with the IR camera, but if the camera is calibrated with a blackbody, then the strong variation of emittance as a function of wavelength must be taken into account when one tries to determine temperature.

An adhesive which is sometimes used in thermal vacuum applications is RTV-732. The directional emittance for RTV-732 is shown in Fig. 12.

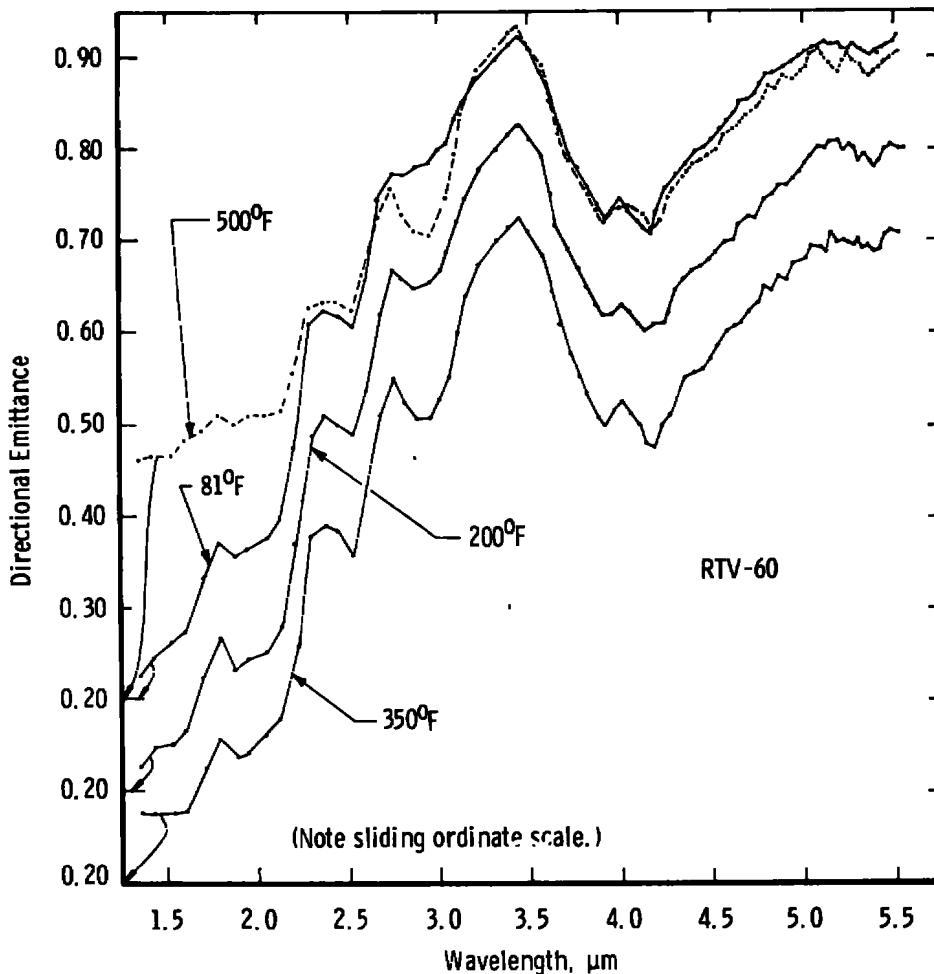

Figure 11. Directional emittance of RTV-60 as a function of wavelength and temperature.

Since thermal vacuum applications only encounter temperatures up to about 200°F, the temperature range was limited to 75 to 200°F. The RTV-732 was found to have no dependence upon temperature and was found to have a strong dependence upon wavelength.

In an effort to find a black paint for high temperature applications, the spectrum of Rust-Oleum 4279 Black was measured. The results in Fig. 13 show that this black paint has several desirable characteristics. It is seen to have a high directional emittance (≈ 0.94), is spectrally very flat (essentially constant with wavelength), and shows no dependence upon temperature in the 85 to 500°F range. This means that this paint would be excellent for use in coating the inside of the calibration blackbody and would also be a good choice to use for painting tunnel models.

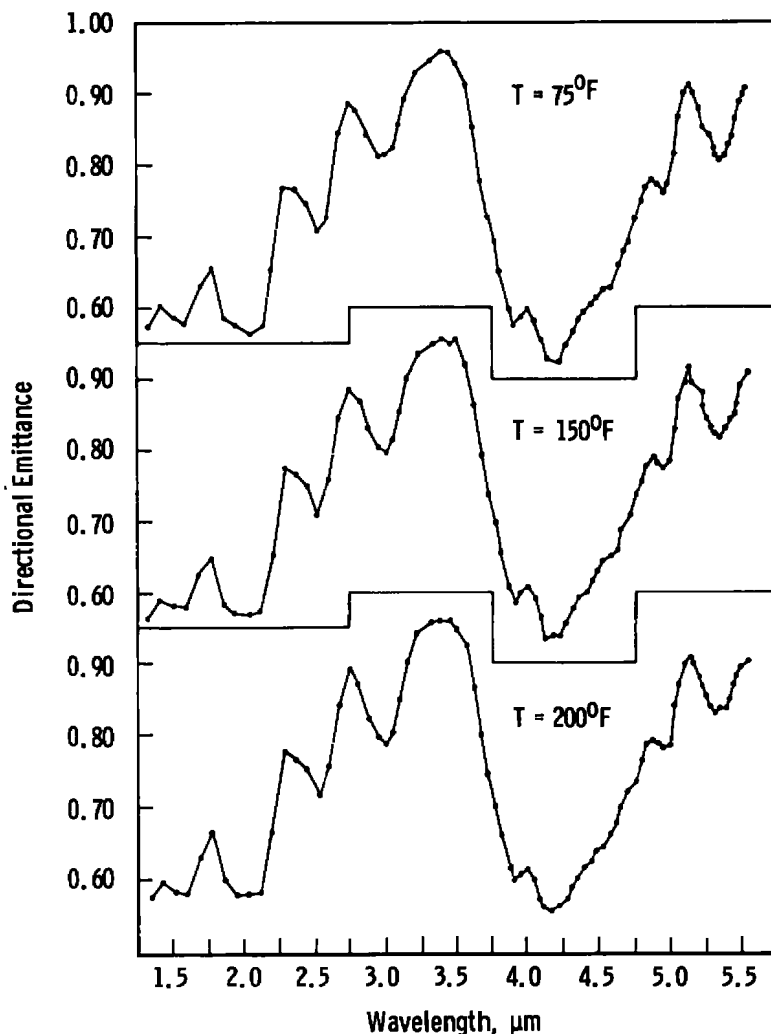

Figure 12. Directional emittance of RTV-732 as a function of wavelength and temperature.

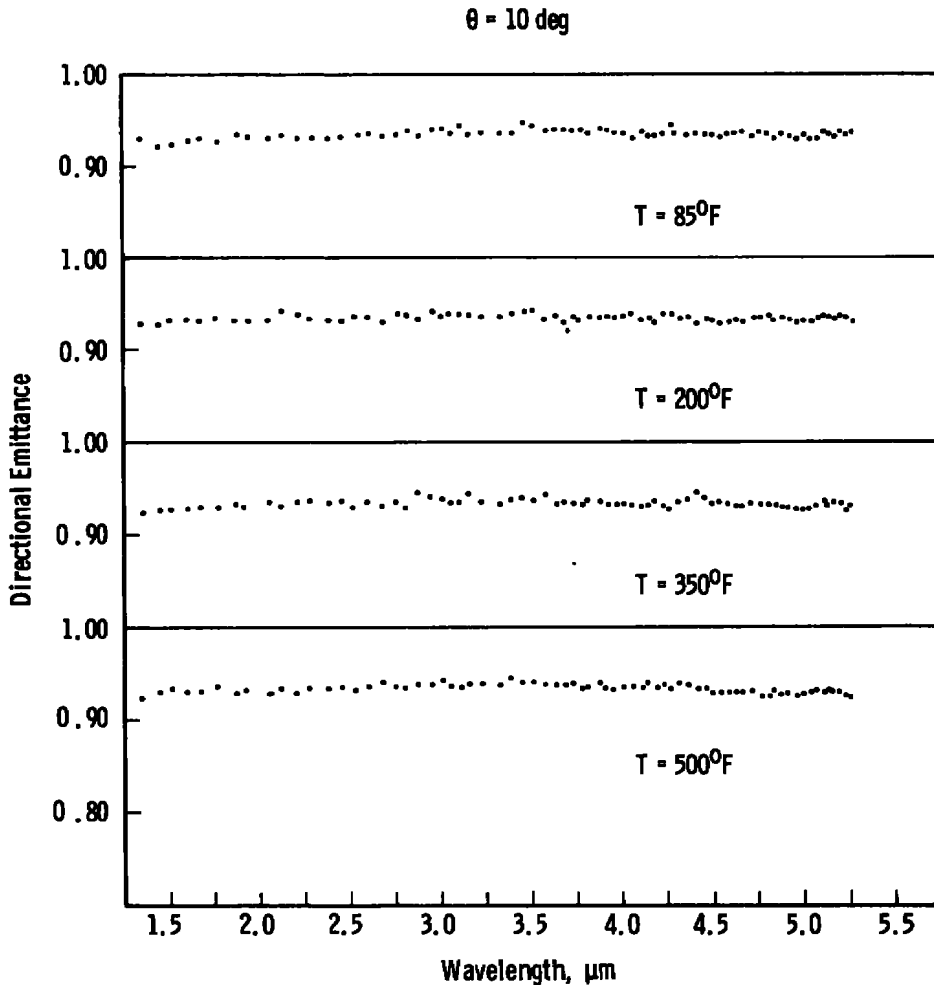

Figure 13. Directional emittance of Rust-Oleum® black paint as a function of wavelength and temperature.

It should be noted for all the data shown in Figs. 10 through 13 that no dependence of directional emittance upon view angle was found. For each case the view angle was varied from near-normal to 30 deg; this is the usual angular range for measuring flux with the IR camera. The angular data were coincident with the 10-deg view angle data and hence will not be shown.

Also shown in this report are the reflectance data obtained with the infrared integrating sphere for the Naval Research Laboratory (NRL) samples. Shown in Figs. 14 and 15 are the hemispherical-directional reflectances of high α and low α copper black. These figures show that the infrared integrating sphere can be used to record data from 0.50 to 5.75 μm .

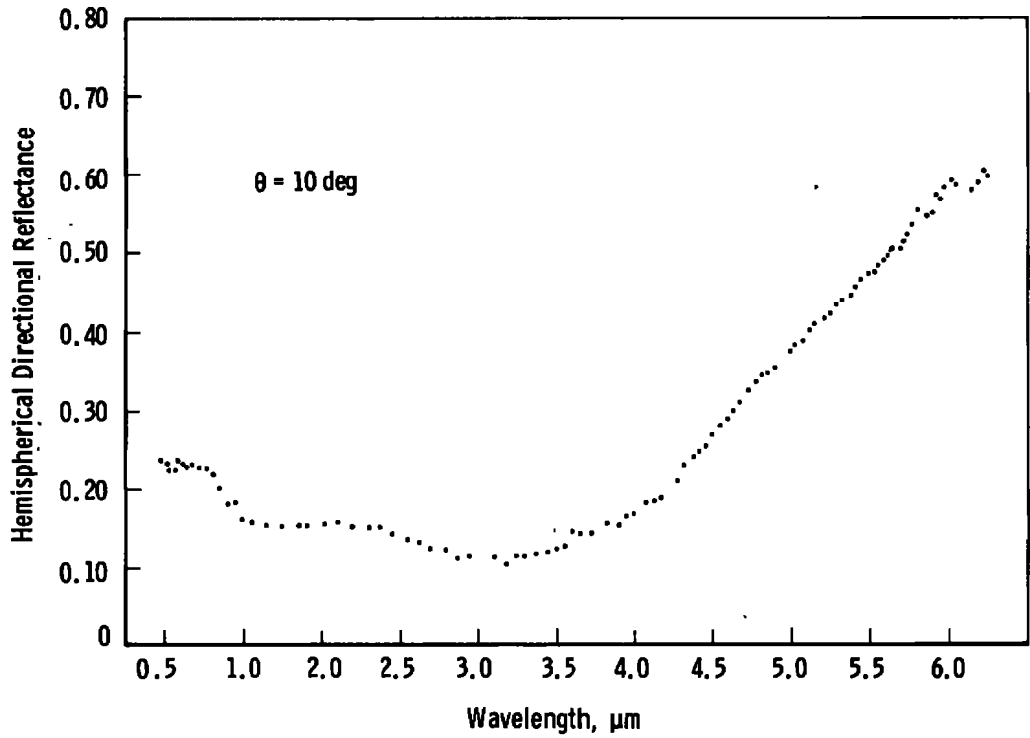

Figure 14. Hemispherical-directional reflectance of high α copper black.

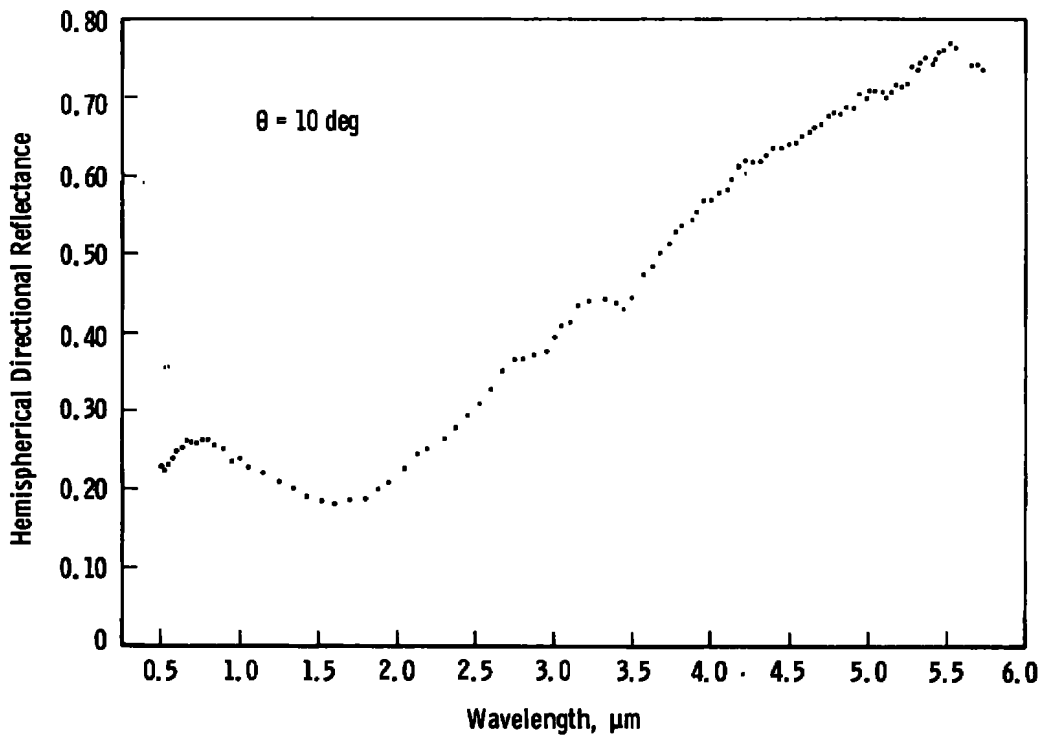

Figure 15. Hemispherical-directional reflectance of low α copper black.

Whenever a blackbody is used to calibrate a detector there is always a question about the uniformity of the emitted radiation across the aperture of the blackbody. To further establish the quality of the calibration blackbody, an intensity scan was made across the diameter of the calibration source. As discussed earlier, the emitted radiation was measured with a pyroelectric detector, and the apparatus used for making the scans is shown in Fig. 9. The results for two scans are shown in Figs. 16 and 17 for blackbody temperatures of 120 and 210°F, respectively. Since the design curves yield a theoretical emittance of 0.999 for this blackbody, then Figs. 16 and 17 may be considered as a directional emittance distribution at normal incidence across the blackbody. Actually, Figs. 16 and 17 were obtained by normalizing by the largest detector output. The distributions show that the blackbody does have a large, flat core and also has a very high emittance (>0.95) across most of its diameter.

This blackbody has been used successfully in calibrating the IR camera below 250°F and has been used in conjunction with both aeroheating tests and thermal vacuum tests.

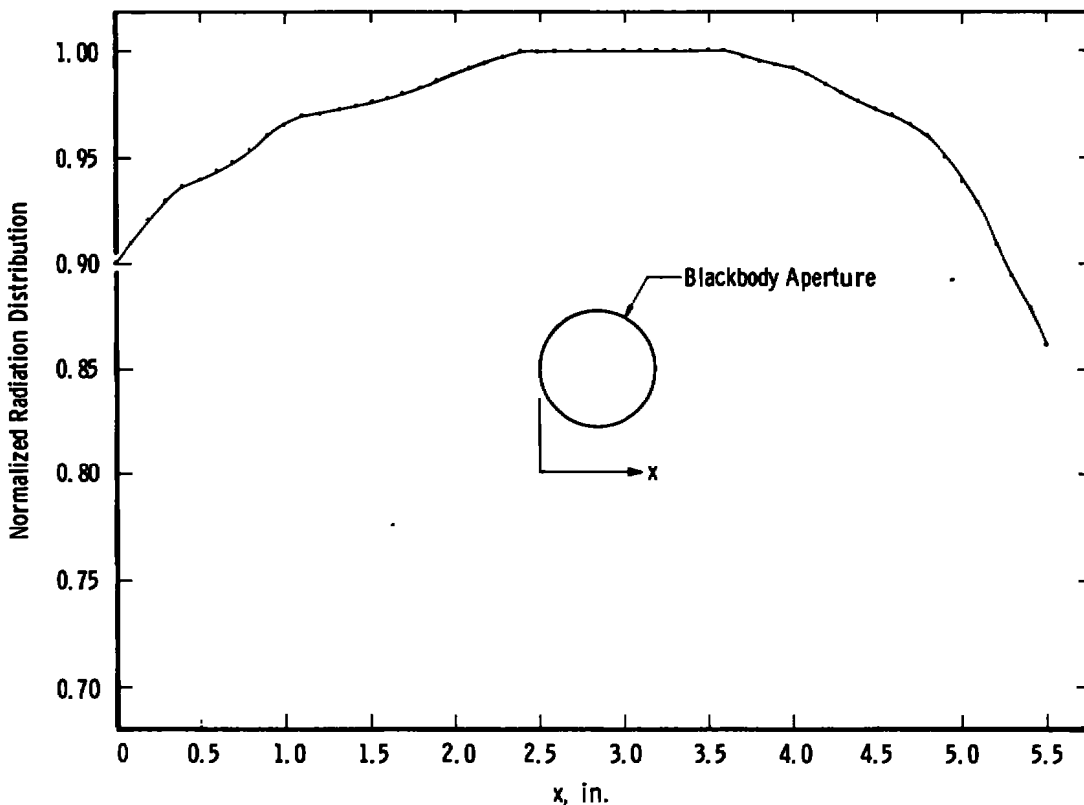

Figure 16. Calibration blackbody-emitted radiation distribution for a source temperature of 120°F.

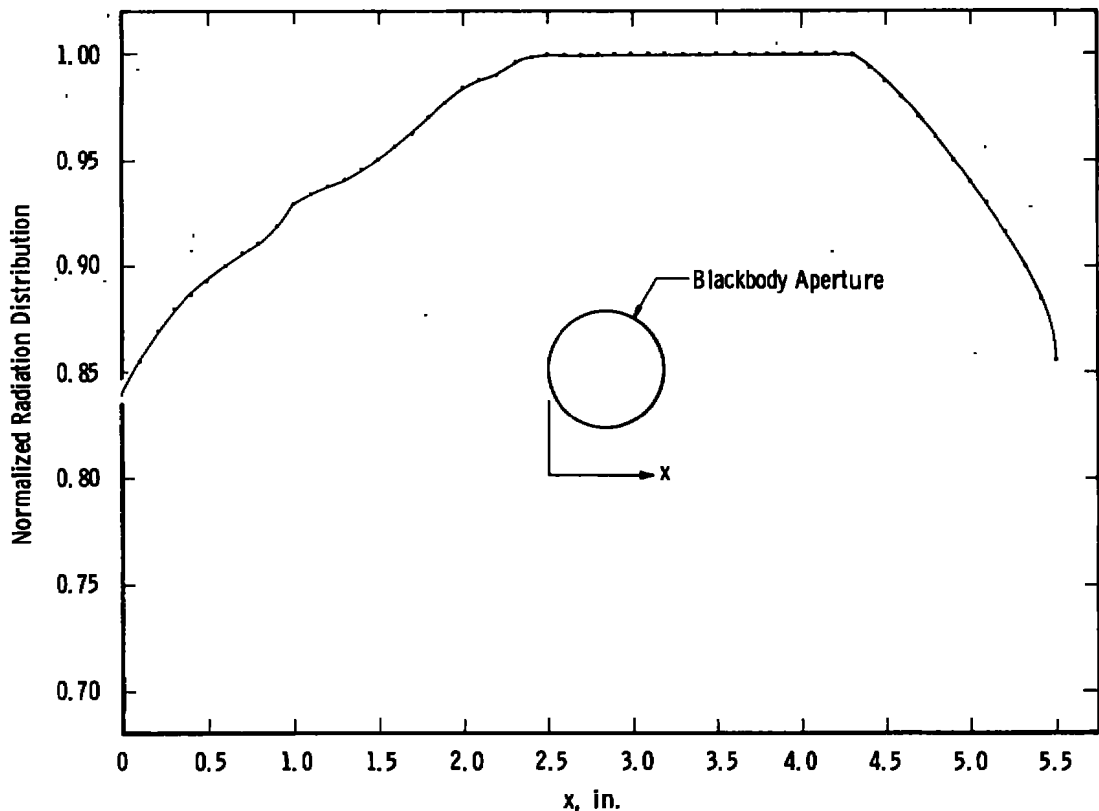

Figure 17. Calibration blackbody-emitted radiation distribution for a source temperature of 210°F.

5.0 SUMMARY AND CONCLUSIONS

An infrared integrating sphere reflectometer has been assembled for measuring the radiative properties (spectral-directional emittance) of surfaces the temperatures of which are to be monitored or measured remotely through use of the IR scanning camera. The reflectometer is available to be used to measure the spectral-directional emittance for other purposes at AEDC. The reflectometer is operational in the wavelength range from 0.50 to 5.5 μm . The temperature range of the samples measured in this report was ambient $\leq T \leq 500^\circ\text{F}$; however, temperatures much higher than 500°F are also possible. The view angle range of the reflectometer is $0 \leq \theta \leq 60$ deg; but measurements were made only for $0 \leq \theta \leq 30$ deg. The samples measured in this report were lexan (before and after exposure to the Tunnel F flow field), RTV-60, RTV-732, Rust-Oleum 4279 black paint, and copper black (high α and low α).

In addition to the assembly of the infrared reflectometer so that the spectral-directional emittance could be measured, a large-aperture calibration blackbody was designed and fabricated for calibrating the IR scanning camera. The reflectometer is important because the spectral-directional emittance of a surface must be known so that its surface temperature can be determined from the IR camera calibration. Also, the reflectometer permits the determination of emittance changes with wavelength, temperature, and view angle. In addition, the reflectometer is helpful in choosing a paint or model material which has desirable radiative properties such as the Rust-Oleum 4279 black paint. The calibration blackbody is important since it permits calibration and is the calibration standard for the IR camera.

REFERENCES

1. Wood, B. E., Smith, A. M., Seiber, B. A., et al. "Infrared Reflectance of CO₂ Cryodeposits." AEDC-TR-70-108 (AD708509), July 1970.
2. Sparrow, E. M. and Cess, R. D. Radiation Heat Transfer. Brooks/Cole Publishing Company, Belmont, California, 1966.
3. Handbook of Military Infrared Technology, edited by W. L. Wolfe. U.S. Government Printing Office, Washington, D. C., 1965.
4. AGA Thermovision System 680/102 B Operating Manual.
5. Hudson, R. D. Infrared System Engineering. Wiley-Interscience Publishing Company, New York, 1969.