

ADA021910

Qualified requestors may obtain additional copies from the Defense Documentation Center. All others should apply to the National Technical Information Service.

Request Form

MIS

SEARCHED  INDEXED

SERIALIZED  FILED

APPROVED FOR RELEASE BY NSA

DATE

BY

REMARKS

A		
---	--	--

UNCLASSIFIED

SECURITY CLASSIFICATION OF THIS PAGE (When Data Entered)

19. REPORT DOCUMENTATION PAGE		READ INSTRUCTIONS BEFORE COMPLETING FORM	
1. REPORT NUMBER	2. GOVT ACCESSION NO.	3. RECIPIENT'S CATALOG NUMBER	
18. AFRL-TR-76-0046			
4. TITLE (and Subtitle)		5. TYPE OF REPORT & PERIOD COVERED	
6. DIGISONDE OBSERVATIONS DURING CHEMICAL RELEASES.		9. Scientific • Final Report 1 Oct. 72 - 30 June 75	
7. AUTHOR(s)		6. PERFORMING ORG. REPORT NUMBER	
10. Klaus/Bibl Bodo W. Reinisch		ULRF-378/IP	
9. PERFORMING ORGANIZATION NAME AND ADDRESS		7. CONTRACT OR GRANT NUMBER(s)	
University of Lowell Research Foundation 450 Aiken Street Lowell, Massachusetts 01854		14. F19628-73-C-0033	
10. PROGRAM ELEMENT, PROJECT, TASK AREA & WORK UNIT NUMBERS		15. VAF 7635-14-01 62101F	
11. CONTROLLING OFFICE NAME AND ADDRESS		13. REPORT DATE	
Air Force Cambridge Research Laboratories Hanscom AFB, Massachusetts 01731 Contract Monitor: Charles Forsberg/LKC		17. 763514 January 1976	
14. MONITORING AGENCY NAME & ADDRESS (if different from Controlling Office)		12. NUMBER OF PAGES	
12. 40p.		42	
15. SECURITY CLASS. (of this report)		15a. DECLASSIFICATION/DOWNGRADING SCHEDULE	
Unclassified			
16. DISTRIBUTION STATEMENT (of this Report)			
Approved for public release; distribution unlimited.			
17. DISTRIBUTION STATEMENT (of the abstract entered in Block 20, if different from Report)			
18. SUPPLEMENTARY NOTES			
19. KEY WORDS (Continue on reverse side if necessary and identify by block number)			
Chemical Release Ionosphere Sporadic E Digital Data Processing Electron Density Profile			
20. ABSTRACT (Continue on reverse side if necessary and identify by block number)			
Ionospheric observations with a Digisonde system during upper atmosphere chemical releases were carried out at Wallops Island (ALADDIN 74) in June 1974. Ionogram observations were combined with angle of arrival and Doppler measurements. Ionogram data of ALADDIN 72 and 74 were analyzed with reference to the chemical releases. Digital techniques were applied for the processing of the ionospheric data. The mobile Digisonde 128 No. 1 was relog (cont. p. 11)			

409596 ✓ 65

UNCLASSIFIED

SECURITY CLASSIFICATION OF THIS PAGE(When Data Entered)

Block 20. Abstract

(cont fr p 1473A)

→ cated several times between Eglin, Florida, J. F. Kennedy Space Center, Florida, and Wallops Island, Virginia.

A

UNCLASSIFIED

SECURITY CLASSIFICATION OF THIS PAGE(When Data Entered)

## PREFACE

This contract was monitored by Mr. Charles Forsberg of AFCRL's Chemical Physics Branch and the authors appreciate the logistics support that he so kindly provided.

Messrs. R. Bemis and J. Gorman of ULRF contributed in all phases of the technical work. Ms. S. Smith took care of the data analysis and computer programming.

## TABLE OF CONTENTS

	Page
1.0 INTRODUCTION	1
2.0 FIELD OPERATION IN EGLIN, FLORIDA	3
3.0 FIELD OPERATION AT KENNEDY SPACE CENTER, FLORIDA	6
4.0 FIELD OPERATION AT WOLLOPS ISLAND, VIRGINIA	7
4.1 Antennas	7
4.2 Transmitter	7
4.3 Peripheral Equipment	10
4.4 Operational Program	10
4.5 System Packing	11
5.0 DATA ANALYSIS FOR ALADDIN 74	13
6.0 COMPUTER PROGRAM FOR AUTOMATIC IONOGRAM REDUCTION AIR	19
7.0 DATA DISPLAY SYSTEM - THE MINICODER	22
7.1 Method of Operation	22
7.2 Mode Controls	25
7.3 Circuitry	26
8.0 SUMMARY	33

## LIST OF FIGURES

Figure No.		Page
1	RHOMBIC ANTENNA	8
2	ANTENNA LAYOUT, JUNE 1974, WALLOPS ISLAND, VIRGINIA	9
3	DOPPLER DRIFT OBSERVATIONS, JUNE 1974, WALLOPS ISLAND	12
4	29-30 JUNE 1974, WALLOPS ISLAND, VIRGINIA	14
5	ELECTRON DENSITY PROFILES, WALLOPS ISLAND, VIRGINIA, 29 JUNE 74, 1300-1900 EST	16
6	ELECTRON DENSITY PROFILES, MAYNARD, MASSACHUSETT, 29 JUNE 74, 1300-1900 EST	17
7	ELECTRON DENSITY PROFILES 29 JUNE 74	18
8	COLLATED IONOGRAMS, MAYNARD, MASSACHUSETTS, 11/12 FEBRUARY 73	21
9	BLOCK DIAGRAM	23
10	WIRING DIAGRAM, MINICODER	24
11	CARD FILE	27
12	TIMER M1	28
13	TIMING DIAGRAM	29
14	SCANNER M2	30
15	54-AMPLITUDE M3	31
16	VERSATEC CONTROL M4	32

LIST OF TABLES

Table No.	DIGISONDE PROGRAMS	Page
1	DIGISONDE PROGRAMS	4

## 1.0 INTRODUCTION

This report is a short account of the logistic and technical effort performed under Contract F19628-73-C-0033 from October 1972 to September 1975. The scientific results of this work have previously been published in Scientific Reports 1 and 2: "Artificially Induced Sporadic E," AFCRL-TR-75-0205. Several papers were presented at scientific meetings and some papers published partially as a result of this contract's research:

### Presentations:

"Chemical Releases at Sunset Trigger Sporadic E," (B. W. Reinisch and M. A. MacLeod) EOS Transactions, American Geophysical Union, 54, 4, p. 379, April 1973.

"The Aladdin II Ionosphere: A Comparison of Theoretical Calculations with Digisonde Observations," (M. A. MacLeod, T. J. Keneshea and B. W. Reinisch) EOS Transactions, American Geophysical Union, 54, 4, p. 381, April 1973.

"Radio Doppler Probing of Ocean Surface," (K. Bibl, W. Pfister, B. W. Reinisch and G. S. Sales), URSI 1973 Meeting, Boulder, Colorado, August 1973.

"Separation of Wave and Drift Motions in the E-Region," (K. Bibl and B. W. Reinisch), International Conference on Recent Advances in the Physics and Chemistry of the E Region, Boulder, Colorado, August 1974.

"Spectral Analysis of E-Region 'Drift' Measurements in Eglin, Florida," (K. Bibl, W. Pfister and B. W. Reinisch), 1975 International IEEE/SP-S Symposium and USNC/URSI Meeting, Urbana, Illinois, June 1975.

### Publications:

"Burnt-Out Rocket Punches Hole Into Ionosphere," (B. W. Reinisch), COSPAR, Space Research XIII, pp. 503-506, 1973.

"The Aladdin Experiment - Part II, Composition," (C. R. Philbrick, R. S. Narcisi, R. E. Good, H. S. Hoffman, T. J. Keneshea, M. A. MacLeod, S. P. Zimmerman and B. W. Reinisch), COSPAR, Space Research XIII, pp. 441-449, 1973.

"The Aladdin II Experiment - Part II, Composition (Preliminary Results)," (C. R. Philbrick, D. Golomb, S. P. Zimmerman, T. J. Keneshea, M. A. MacLeod, R. E. Good, B. S. Dandekar and B. W. Reinisch), COSPAR, Space Research XIV, pp. 89-95, 1974.

"Velocities of Small and Medium Scale Ionospheric Irregularities Deduced from Doppler and Arrival Angle Measurements," (K. Bibl, W. Pfister, B. W. Reinisch and G. S. Sales), COSPAR, Space Research XV, 1975.

This report limits itself to an accumulative recapitulation of information provided in the periodic reports prepared under this contract.

## 2.0 FIELD OPERATION IN EGLIN, FLORIDA

In Spring 1973 it was intended to operate the Digisonde No. 1 at the John F. Kennedy Space Center in Florida. We, therefore, reconverted the Eglin station into a mobile system. All equipment previously housed in the building on Site A-18 was installed in the house trailer to have a fully mobile system.

Satisfactory performance of the system in the trailer was verified for two modes of operation, one, without drift attachment recording ionograms on magnetic tape and paper, and two, including the drift attachment alternating between drift and ionogram observations. Since only one tape recorder was available we recorded the drift data on tape and the ionograms on paper. Using the drift mode operation sea scatter observations were carried out at 5.6 and 6.5 MHz for many hours. To avoid ionospheric echoes the range gates were set to 40 km. Fourier analysis of these data showed the expected Bragg scatter lines at  $\pm 0.25$  Hz (see Scientific Report).

Prior to testing the ionogram mode two improvements had been incorporated into the Digisonde. One was a flexible ionogram sequence program controlled by thumbwheel switch TA on the front panel of the Memory. The twelve available Digisonde programs are listed in Table 1. The other was a new Memory Operation card which provides different height sample spacing for E- and F-region. The 128 height samples are controlled by the K-switch in the following way:

K = 1	128 × 1.5 km
K = 2	64 × 1.5 km + 64 × 3.0 km
K = 3	128 × 4.5 km
K = 4	32 × 3.0 km + 96 × 6.0 km

TA Switch	START		
	A' Ionogram	A Ionogram	B Ionogram
1		0.5', 1.5', 2.5', ....., 59.5'	
2		1.5', 6.5', 11.5', ....., 56.5'	
3	59.0'	9.5', 19.5', 29.5', 39.5', 49.5'	
4	59.0'	14.5', 29.5', 44.5'	
5	59.0'	29.5'	
6	59.0'		
9			0.0', 1.0', 2.0', ....., 59.0'
10		1.5', 6.5', 11.5', ....., 56.5'	4.0', 9.0', 14.0', ....., 59.0'
11	59.0'	9.5', 19.5', 29.5', 39.5', 49.5'	4.0', 14.0', 24.0', 34.0', 44.0', 54.0'
12	59.0'	14.5', 29.5', 44.5'	9.0', 24.0', 39.0', 54.0'
13	59.0'	29.5'	9.0', 39.0'
14	59.0'		9.0'

DIGISONDE PROGRAMS

TABLE 1

Since the sampling range usually starts at 60 km the entire E-region up to 156 km altitude is sampled with double sampling accuracy for  $K = 2$  and  $K = 4$ .

The transmitter final stage had to be repaired since the 6000 V power supply was defective. Bit errors on the magnetic tape revealed that the Cipher tape recorder was again not writing properly. This machine had been repaired several times without ever arriving at a satisfactory performance. We therefore recommended its replacement by a different brand tape drive.

The three crossed-loop antennas that were used in Eglin for reception of ionogram and drift mode echoes were disassembled and the parts stored inside the trailer for shipment to the Kennedy Space Center.

### 3.0 FIELD OPERATION AT KENNEDY SPACE CENTER, FLORIDA

In August 1973 Digisonde No. 1 started operation at Kennedy Space Center under a Navy contract with Atlantic Science Corporation, Indialantic, Florida. Foundation personnel assisted in the initial phases of the operation by remote and on-site consultation. ULRF installed two new remote data outputs, one, feeding the hourly ionograms through telephone line to Patrick Air Force Base, Florida, and two, connecting all ionograms to a telephone data set, so that any interested party has access to the ionograms by telephone.

The remote printout capability required a minimum of operation from the Air Weather personnel at Patrick: 10 minutes after the hour the printed ionogram can be removed from the Xerox Telecopier and a new sheet of paper is positioned in the machine. The next hourly ionogram will automatically start being printed at the 59th minute. Use of continuous roll feed paper eliminates the need for the hourly paper change. This remote ionogram printout is still being used at the time of this writing.

An on-site Xerox Telecopier provides the on-line ionogram prints. A new roll of paper must be installed about once a week when only hourly ionograms are recorded.

## 4.0 FIELD OPERATION AT WALLOPS ISLAND, VIRGINIA

During the ALADDIN 74 rocket campaign at Wallops Island we monitored the ionosphere from 15 to 30 June 1974 using the ionogram and drift mode of operation. The data are stored on digital magnetic tape.

### 4.1 Antennas

For transmission a three-wire rhombic antenna with a height of 85 feet was erected at Site V-65 (Figure 1). The three crossed-loop antennas for reception arrived together with the Digisonde in the trailer shipped from Kennedy Space Center. Some brush had to be cleared to locate the antennas as shown in Figure 2.

### 4.2 Transmitter

The Granger 30 kW transmitter was found to be inoperative and considerable effort was invested to not only repair but also to improve the reliability of the transmitter.

- A. Transformers of a new design were installed at the input and output.
- B. Plate and grid lines were replaced.
- C. The grid pulser was found to have a faulty design. Previously only two of every three pulses was transmitted. The grid pulser was redesigned to produce every pulse.
- D. Modification was made which allows the transmitter to run at 6 kV plate voltage rather than 9 kV; this increases the reliability.

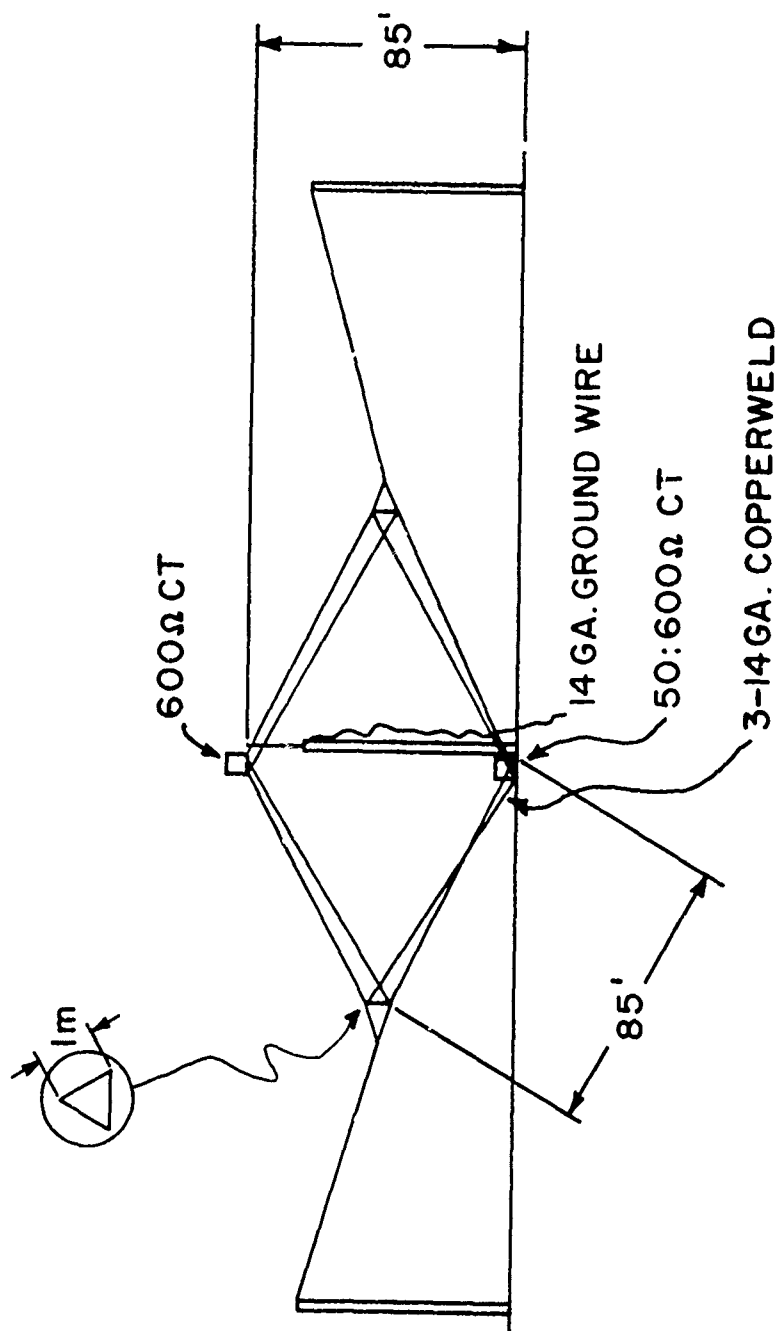
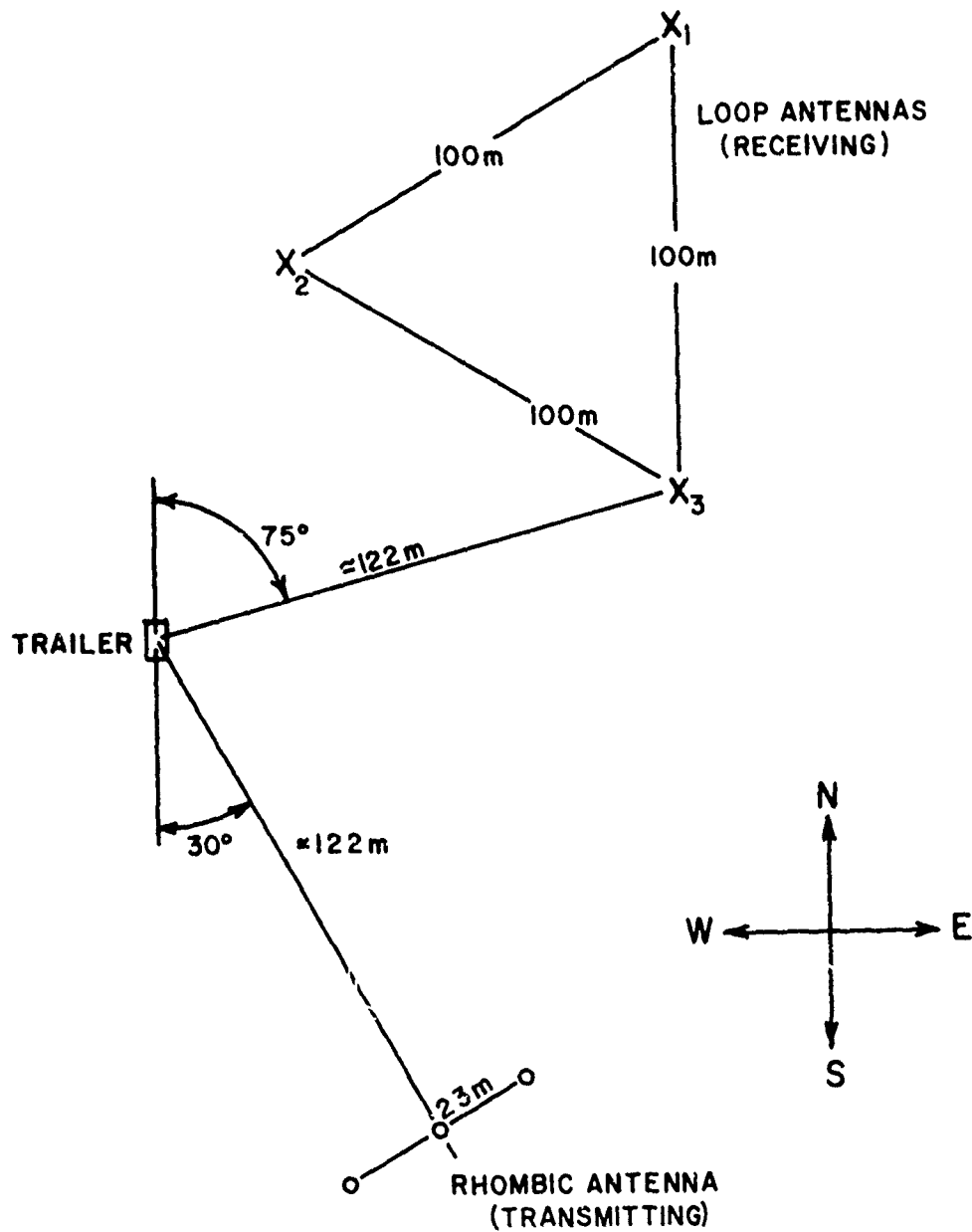

FIGURE 1



ANTENNA LAYOUT  
 JUNE 1974  
 WALLOPS ISLAND, VA.

FIGURE 2

### 4.3 Peripheral Equipment

We had managed to provide two digital tape recorders of different make for the experiments, one to record the drift data, the other the ionograms. Unfortunately, the drift recorder failed just when the first rockets were launched. It was then decided to forsake the tape recording of the ionograms and connect the second tape drive to the drift chassis. Some differences in the tape drive interface requirements produced errors in the writing of tape. This was noticed only after the experiments when we checked the data in the computer and at the Foundation's Digicoder system. The error was diagnosed as the missing of characters. It is believed that the data can be "repaired" with only a moderate effort, so that computer processing of this most important phase of the ALADDIN mission can be undertaken.

### 4.4 Operational Program

During the launch period ionogram and drift observations were alternated in a 2.5 min sequence. The ionograms were scanned in 50 sec, and drift data were collected for 96 seconds. Two types of ionograms were automatically alternating every five minutes. Ionogram A stepped from 1 to 6 MHz in 50 kHz frequency increments covering the height range from 60 to 156 km in 1.5 km and from 156 to 345 km in 3.0 km height increments. The pulse repetition rate was 400 Hz and the signal integration time was 0.2 sec during chemical releases and 0.4 sec otherwise. Program B stepped from 2 to 12 MHz in 100 kHz frequency increments covering the height range from 60 to 726 km with 3.0 and 6.0 km height increments for E- and F-region respectively. Pulse repetition rate for Program B was 200 Hz and integration time 0.4 sec. While Program A gives more detailed information about the E-region, Program B monitors high critical frequencies of Es layers and the be-

havior of the F-region. All ionograms were printed on paper and simultaneously recorded on digital magnetic tape for later computer processing or play back.

Doppler-drift measurements were carried out for more than 100 hours covering night, twilight and day conditions. Depending on the ionospheric conditions we monitored one or several layers simultaneously. Multiple echoes were monitored to find their incidence angle and to compare their spectral characteristics with those of the first echo (Figure 3).

During the days before the rocket launches the length of the data samples was often extended to 144 seconds every 2.5 minutes to permit a higher Doppler frequency resolution. Most of the time the system was operated in the "Slow Mode", previously described in a report by Bibl, Gorman and Reinisch (LTIRF-358/IP, 1973). This mode takes six independent samples with each antenna every quarter of a second. By setting  $f_1 = f_2 = f_3$  and  $f_4 = f_5 = f_6$  we often measured with only two frequencies, each of them having three range gates spaced in general by 3.0, 4.5 or 6.0 km. During E-region profile measurements ( $P_E$  in Figure 3) all six frequencies were made different and the range set in the middle of the echo pulse. One or more of these samples were occasionally used to monitor the surface of the ocean by measuring the sea scatter. More sea scatter measurements were made at times when the system was unattended.

#### 4.5 System Packing

At completion of the rocket experiments the Digisonde trailer was prepared for return shipment to J. F. Kennedy Space Center. The three loop antennas were disassembled and stored inside the trailer. The rhombic antenna was left at its place.

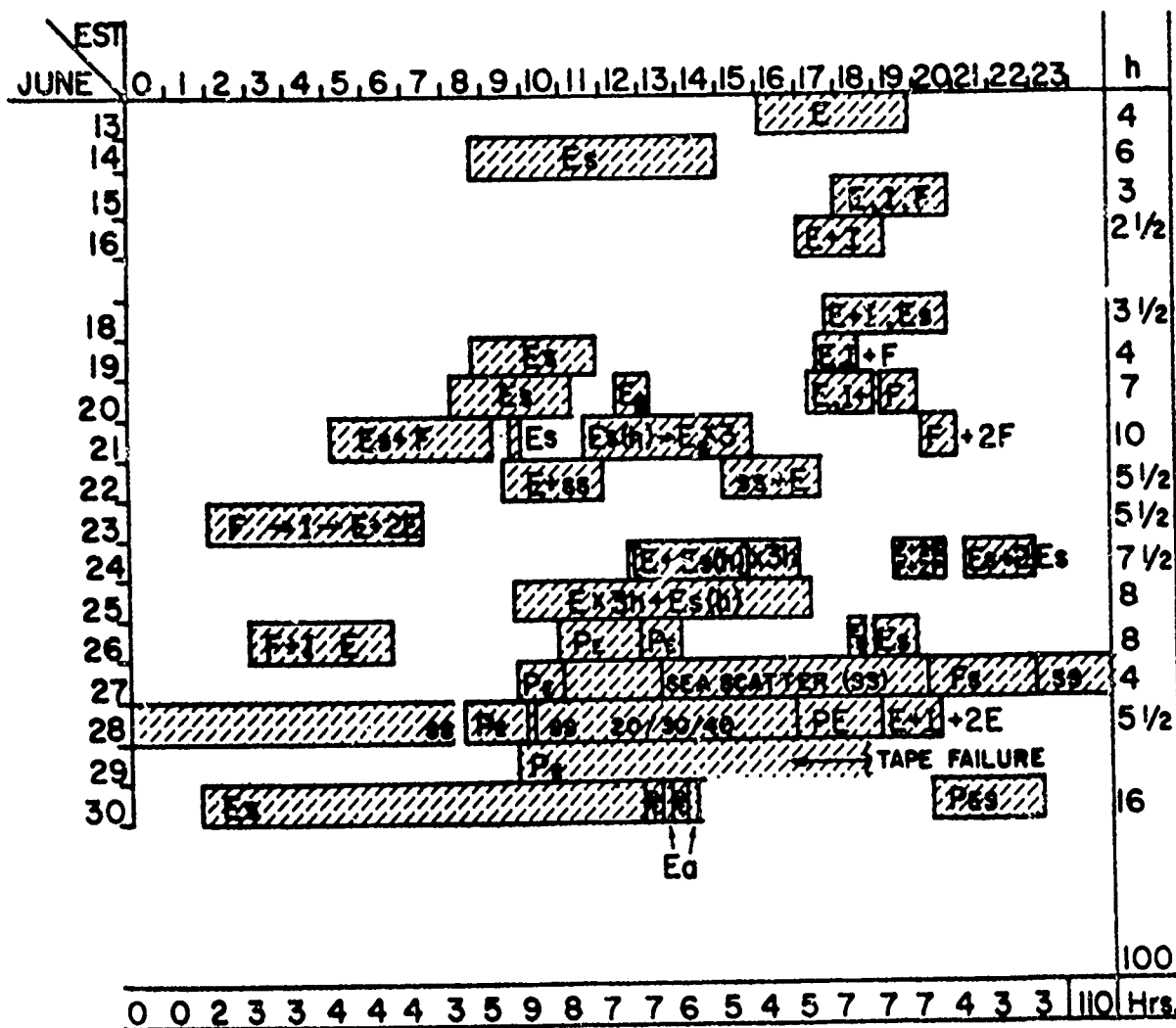

E	E-Layer	I	Intermediate Layer
Es	Sporadic E-Layer	2E, 2F	Double Echoes
Ea	Aurora E	P <sub>E</sub>	Profile (E-Region)
F	F-Layer	SS	Sea Scatter
Fs	Spread F		

DOPPLER DRIFT OBSERVATIONS

JUNE 1974

WALLOPS ISLAND

FIGURE 3

## 5.0 DATA ANALYSIS FOR ALADDIN 74

Ionogram and drift data were collected from 15 June to 30 June 1974. While the ionograms were analyzed in terms of critical frequency, height and electron density profiles, we were not able with the existing funding to interpret the drift data in terms of ionospheric structure and drift velocities.

We had shown in the Scientific Report that the activity of sporadic occurrence was high during the second half of June. Critical frequencies of  $f_oE_s > 6$  MHz were observed frequently during day and twilight hours, and values up to 4 MHz were observed at night. As discussed in the Scientific Report, we had expected the development of strong Es-layers after the releases of metallic chemicals above the E-region.

The time history of the critical frequency and height of the sporadic E layers during the 26 hour period from 12h on 29 June to 14h EST on 30 June 1974 is shown in Figure 4. The times of chemical releases are indicated by small arrows on the time axis. The fast sequence of releases makes it difficult to associate the sudden occurrence of an Es layer with any specific release. The upper half of Figure 4 shows  $f_oE_s$ , the lower half the observed virtual heights and the range spread. New sporadic E layers occur at 1530h and 2040h on 29 June, and at 0230h and 1030h EST on 30 June. While the TMA release at 0100 EST does not show any immediate effects, it is rather likely that the new Es layer appearing at 0230 EST is the result of the 0230 TMA release. The critical frequency becomes 5.6 MHz, decays to 4 MHz an hour later, and jumps up to 6.5 MHz after the next TMA release at 0230 EST. The noon releases of Na and Li fall into a time where the Es ionization was already very high with values of  $10^{12}$  el/m<sup>3</sup>.

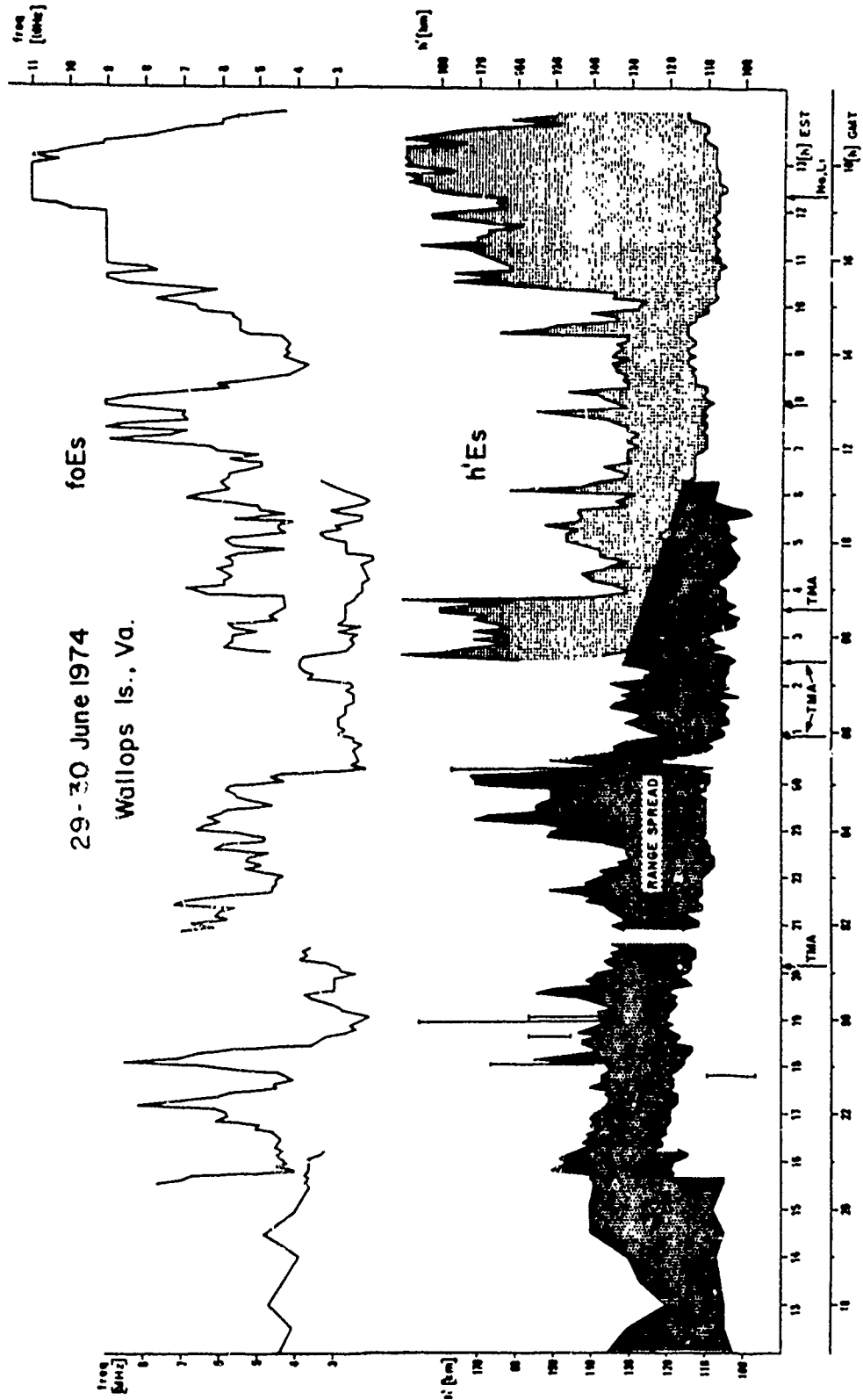

FIGURE 4

At the beginning of the launch series a weak non-blanketing Es layer existed with critical frequencies around 4 MHz. The apparent range spread of 15 to 20 km corresponds to the pulse width of 100  $\mu$ s. Essential range spread is observed after 2230h, 0230h and 1000h. We know that the spread at 0230h is caused by oblique echo returns, since the low Es layer at 100 km blankets any overhead ionization above it. The extraordinary large range spread after 0230 EST can not be explained that easily. Information about the incidence angles of the echo returns can only be obtained from the Doppler-drift data.

Vertical electron density profiles were calculated from the digital ionograms for the afternoon of 29 June. Figure 5 shows the hourly sequence of profiles from 18 UT to 24 UT, i.e. 13 EST to 19 EST. The E-layer electron density had decreased to  $0.8 \times 10^{11} \text{ m}^{-3}$  at 23 UT, and decayed to  $0.5 \times 10^{11} \text{ m}^{-3}$  at 2400 UT. For comparison we analyzed the ionograms from AFCRL's Digisonde in Maynard, Massachusetts (courtesy of Mr. Raymond Cormier, AFCRL). The profiles for the same times are shown in Figure 6. It can be seen that at 24 UT the E-ionization at Maynard has reached the value of  $0.4 \times 10^{11} \text{ m}^{-3}$ . The decay of the E and F1 ionization in the evening sets in somewhat earlier in Maynard, understandably so since Maynard is located four degrees east of Wallops, corresponding to a difference in solar time of 16 minutes. Profile comparison for equal solar time is made in Figure 7. At 1400 EST the profiles for Wallops (solid curve, marked 1344) and Maynard (dashed curve, marked 1400) measured at equal solar time are agreeing very closely. At 1800 a small difference is found in the peak E ionization amounting to  $.16 \times 10^{11} \text{ m}^{-3}$ , or 200 kHz in foE. This comparison shows, that profiles derived from incoherent scatter observations at Millstone Hill, Massachusetts are of value for the ALADDIN 74 program.

# Electron Density Profiles

Wallops Is., Va.

29 June 74, 1300-1900 EST

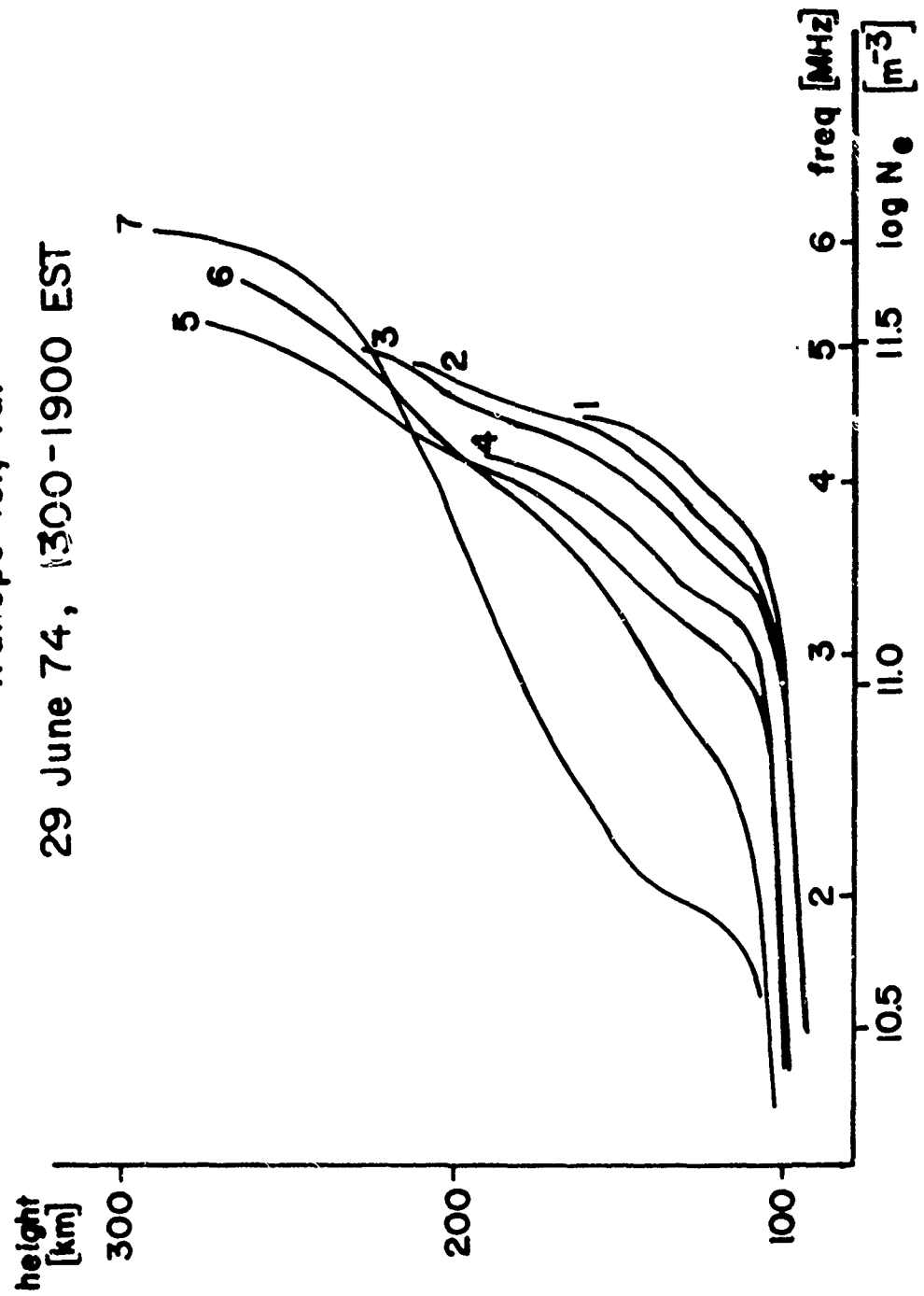

FIGURE 5

**Electron Density Profiles**  
**Maynard, Mass.**  
**29 June 74, 1300-1900 EST**

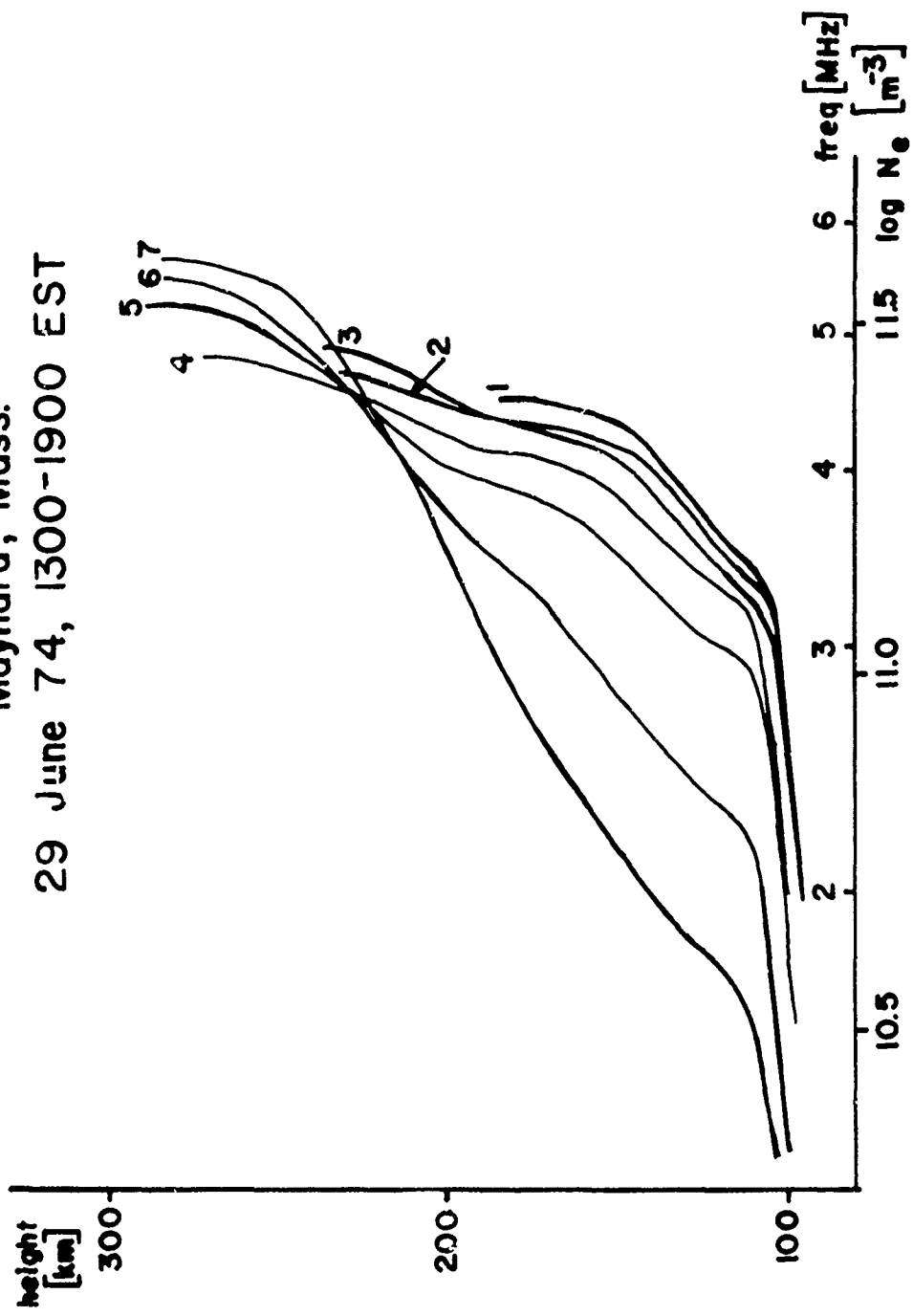

FIGURE 6

# Electron Density Profiles

29 June 74

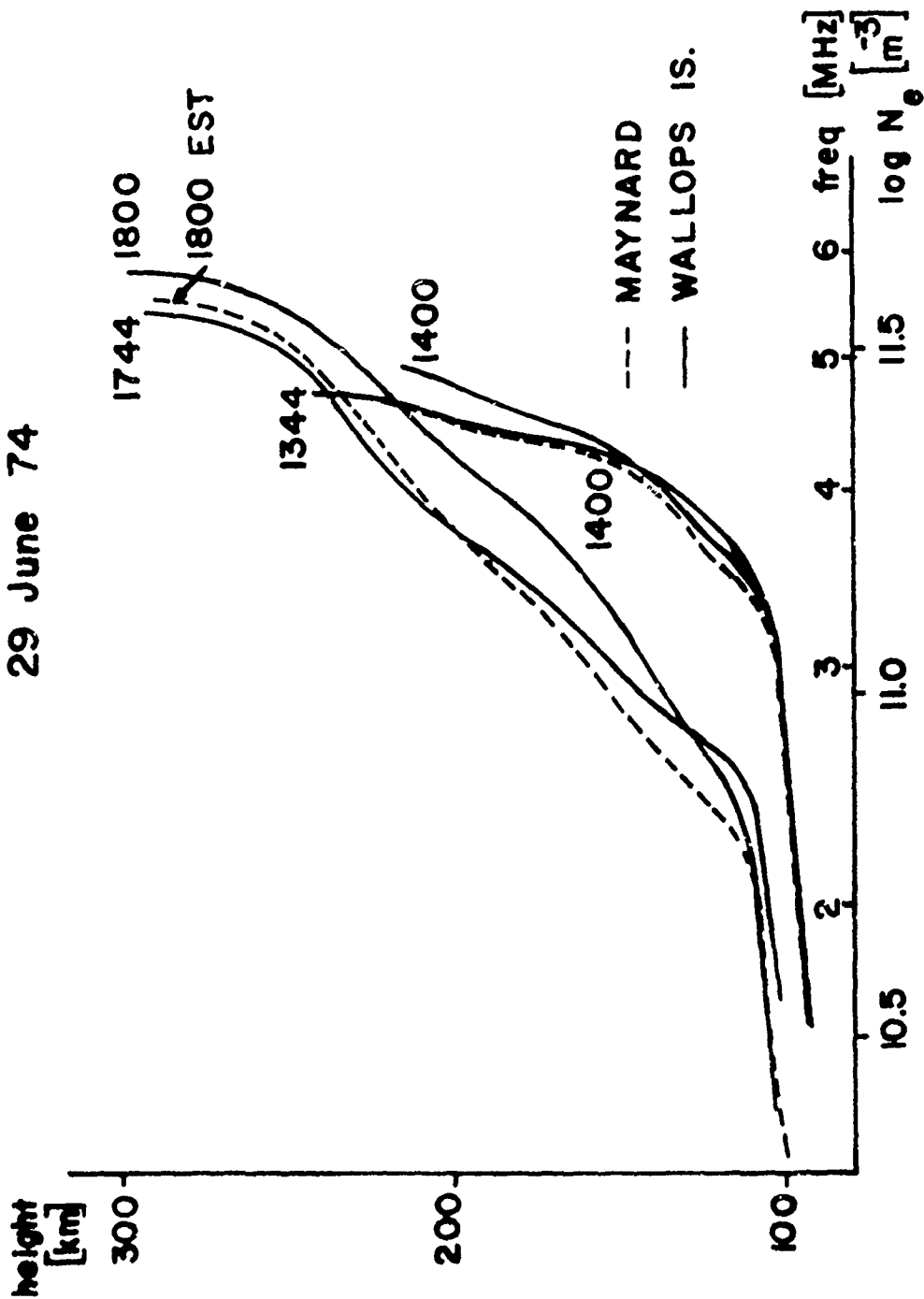

FIGURE 7

## 6.0 COMPUTER PROGRAM FOR AUTOMATIC IONOGRAM REDUCTION AIR

In 1971 we had developed a computer program that extracted from the tape recorded digital ionogram of the Digisonde the echo traces for the E- and F-region reflections (Bibl and Reinisch, 1972). The algorithm first finds the largest pulse signal, determines the amplitude (in dB), and by comparison with the neighboring sounding frequencies decides whether it is an echo or not. A pulse matching procedure is then applied to determine the virtual height of the echo in terms of the Digisonde's height gates.

Spacing of the height gates in the Digisonde is either 1.5, 3.0, 4.5 or 6.0 km and bi-linear height scales are used if the K-switch is set to 2 or 4 as explained in Section 2.0. Originally the AIR program retrieved the virtual heights of the echoes with the resolution given by the Digisonde's sample spacing. It is clear, however, that interpolation between the spaced samples can be performed so as to increase the resolution.

We devised an average deviation technique to fit a "standard pulse" to the normalized data. We prescribe only the start of the pulse since the trailing edge is relatively undefined because of spread echoes. The standard pulse is defined by 10  $\mu$ sec (or 1.5 km) samples with the amplitudes {0, 0, 0, 6, 12, 18, 18, 18} in the logarithmic number scale of the Digisonde. This corresponds to an echo amplitude of about 20 dB above noise and a pulse rise time of 30  $\mu$ sec. We arrived at these values as a characteristic average seen on many ionograms.

The program detects first the echo amplitude and then corrects all 128 amplitude samples by adding or subtracting (remember the logarithmic scale) the number required to

make the average peak amplitude equal to 18. Incrementing the standard pulse in 10  $\mu$ sec steps from 10 height bins (original Digisonde bin spacing) below to 10 bins above the height at which the maximum amplitude was found, the average deviation over eight amplitude samples (later 16) is calculated after each incrementing and the height with the minimum average deviation determines virtual height of the echo. The third zero in the standard pulse, where the pulse amplitude is 20 dB below the echo peak, is defined as the echo height.

This new algorithm was incorporated in the computer program by Miss Sheryl Smith of the Research Foundation. The program was routinely applied to ionogram data from Maynard, Massachusetts (Figure 8).

The AIR program formed the basis for the Automatic Ionogram Collator, AIC, an on-line hardware attachment to the Digisonde which we developed for the U.S. Air Force (Bibl and Reinisch, 1973) and the U.S. Army.

COLLATED IONOGRAMS  
MAYNARD, MASS.  
11/12 FEB 73  
(JULIAN DAY 042/043)  
ECHO AMPLITUDES IN 5dB INCREMENTS

E-REGION

F-REGION

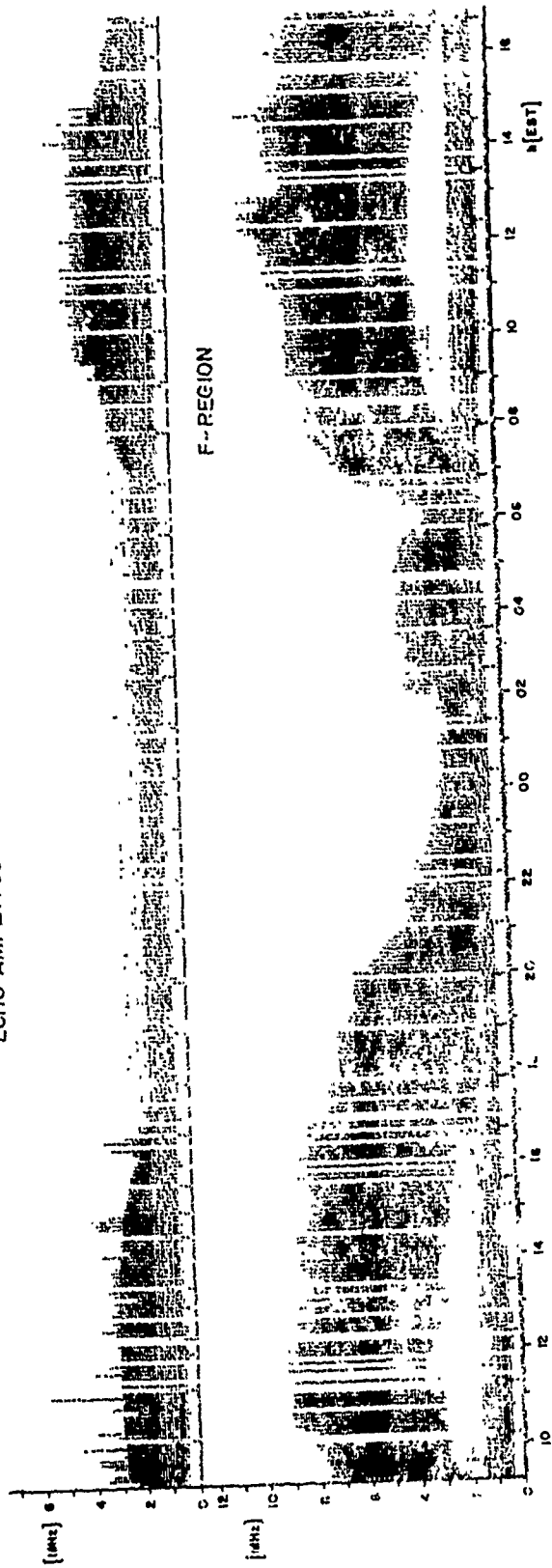

FIGURE 8

## 7.0 DATA DISPLAY SYSTEM - THE MINICODER

Purpose of the Minicoder system is to provide a hard copy output for the data generated in AFCRL's DATAMATE-16 minicomputer. Since the minicomputer has no I/O port available to connect to the Minicoder it was decided to use the tape recorder I/O port. The tape recorder in turn will be slaved through the Minicoder, as shown in the block diagram of Figure 9 and the wiring diagram of Figure 10. Connector CM connects to the tape recorder DMA I/O port of the DATAMATE. The cable is split such that only the necessary data and control lines go to the Minicoder.

### 7.1 Method of Operation

After the Minicoder (M) gives a READY command to the computer (C), M is ready to accept one data record. The data will be printed as one line of up to 256 numbers. When printing of the line is completed the M issues a new READY command to the computer. No READYS will be issued when M is in STOP position.

The six parallel data lines WD7, WD6, WD5, .... WD2 are being used as data bus, with WD7 being the least significant bit. Each 6-bit character is treated as an independent binary number. If a large number or letter font is selected, up to 128 numbers (or letters) can be printed in a line; if the small number font is selected up to 256 numbers are printed in a line. If more than 128 (or 256) characters are contained in a record only the first 128 (or 256) are printed.

To start the Minicoder system the computer must issue a SELECT 1 command after the Versatec plotter has been powered and M was switched to RUN. Since the tape recorder is activated by the SELECT 0 line, no tape recording will occur

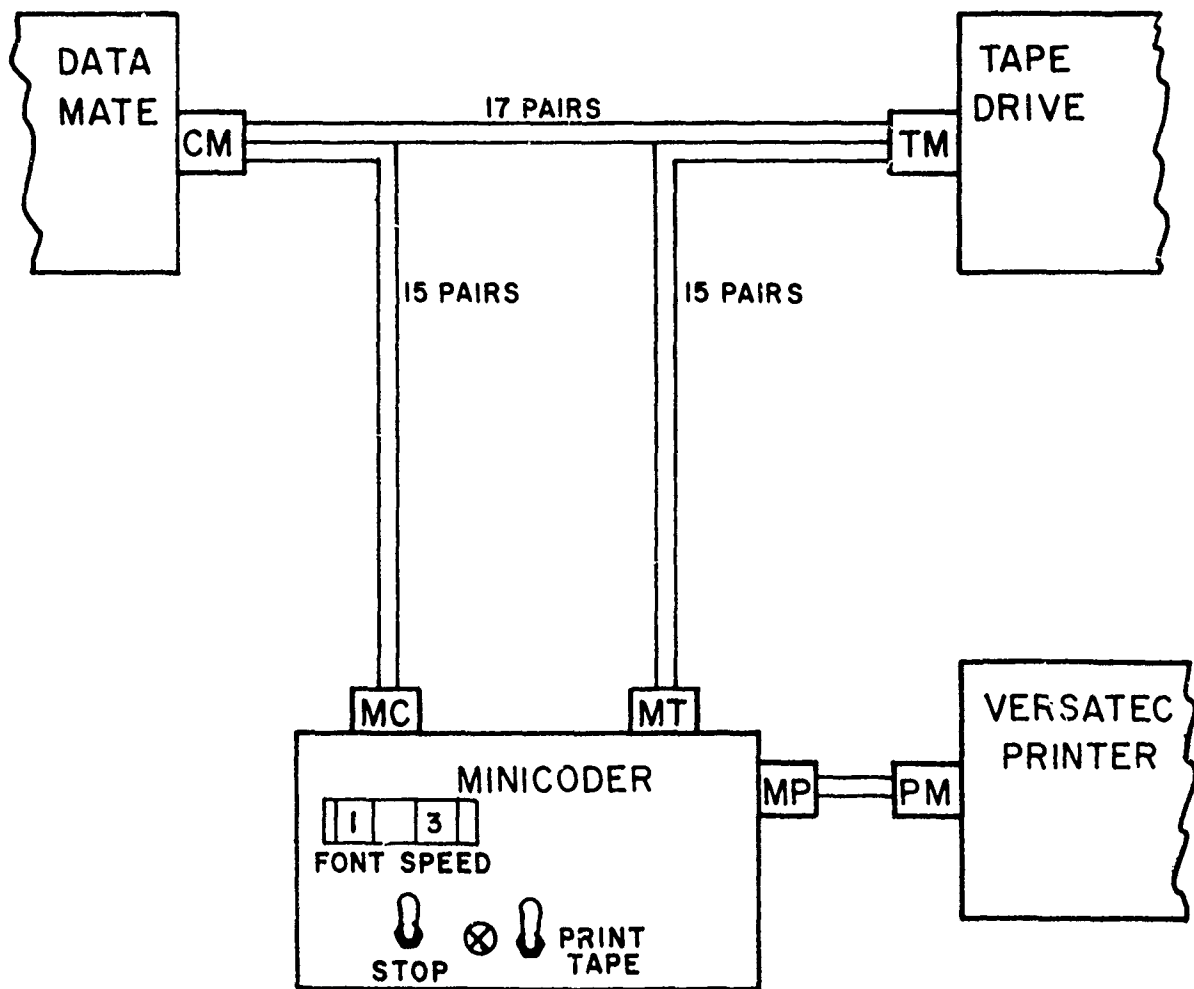

BLOCK DIAGRAM

FIGURE 9

WIRING DIAGRAM,  
MINICODER

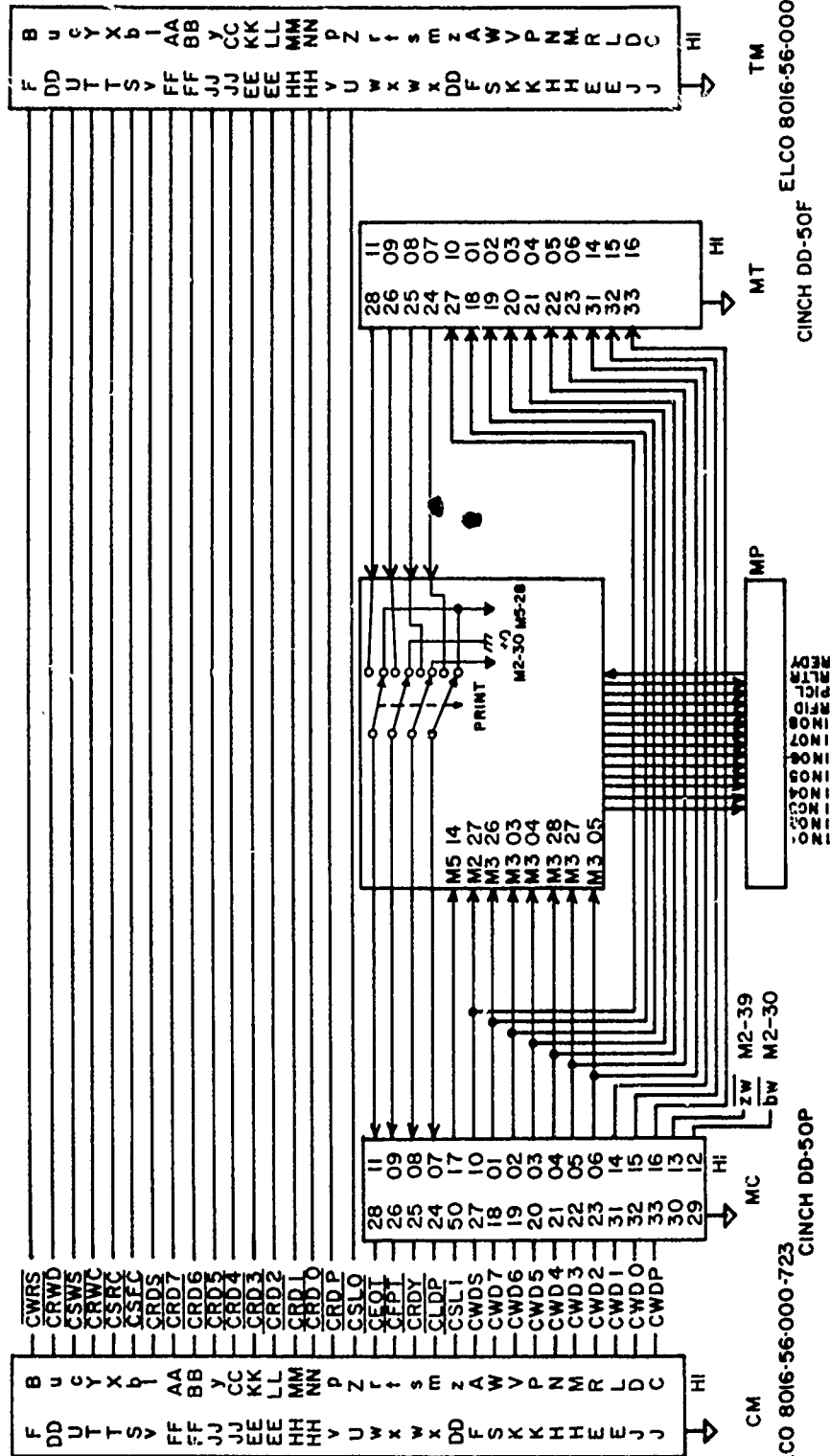

WIRING DIAGRAM

FIGURE 10

ELCO 8016-56-000-723  
CINCH DD-50F  
ELCO 8016-56-000-723  
TM  
ELCO 8016-56-000-723  
CINCH DD-50F  
ELCO 8016-56-000-723  
CM  
ELCO 8016-56-000-723  
CINCH DD-50P

during printing. After all information has been printed a REMOTE FORM FEED command to the Versatec printer can be initiated by deactivating the SELECT 1 line.

## 7.2 Mode Controls

M's control functions are very simple. To bring the Minicoder into operation, the STOP/RUN toggle switch must be set to RUN and the PRINT/TAPE switch to PRINT. Power of the Versatec printer must be turned on. When setting the RUN switch a READY command will go to C. When C activates the SELECT 1 line the red indicator light aside of the PRINT/TAPE switch will be lit. Two thumbwheel switches control the font and the speed of the printing. Highest printing speed is 7, lowest speed is 0. The font switch selects the following printing fonts:

Switch	Font
1	256 small 16-level numbers
2	128 big 16-level numbers with gray modulation
3	128 two-digit numbers
4	alphanumeric
6	128 big 16-level numbers

If one or both of the two thumbwheel switches is set to 8, C takes over speed and/or font control. The first character in each data record controls font and speed for the line (if the corresponding switch is set to 8). The three bits for the speed are on the bus lines WD7, WD6 and WD5, and the three bits for the font are on WD4, WD3 and WD2. The control numbers are the same as the manual switch positions, but in negative logic.

### 7.3 Circuitry

Four printed circuit boards are housed in a card file the wiring of which is shown in Figure 11. The TIMER M1 (Figure 12) senses the data strobes arriving from the computer, counts the number of strobe pulses, fills up or chops the line and provides the transfer and scanning pulses (Figure 13) on pin 28 for the SCANNER M2. The TIMER also contains the system oscillator with controllable frequency (chip 1).

The SCANNER M2 (Figure 14) has two 6-bit shift registers, one with 128 addresses, the other with 256. Either the front panel switch FONT or bits r4, r5, r6 of the first character in a line decides by means of  $\overline{Q256}$  which of the two shift registers is selected. This decision, brought to pin 11 ( $\overline{es}$ ), is also fed to the TIMER. The printing speed information on pins 36 and 39 (R1 and R2) controls the oscillator on the TIMER.

The 64-AMPLITUDE card M3 (Figure 15) generates the different patterns available to the Minicoder. The six data bits  $\&w1-\&w6$ , the four scan line bits  $\lambda1-\lambda4$ , and the three column bits  $\pi1-\pi3$  control whether a black dot or space (pin 9) will be printed. The PROM in position 5 (0) generates the 16-level Optifont (0 to 15). The PROM chip 18 (06) controls the gray shading of the double side Optifont. The ASCII font is generated with ROM chip 2/3 and the Selector chip 7. The BCD font (0-64 in two digits) is generated with the help of the Binary-to-BCD decoder chip 9 and the three PROMs 10, 13 and 14.

The VERSATEC CONTROL card M4 (Figure 16) forms an 8-dot parallel output (IN01-IN08) from the serial dot stream  $\overline{\pi0}$  and provides the necessary commands for the Versatec electrostatic plotter Matrix 1100.



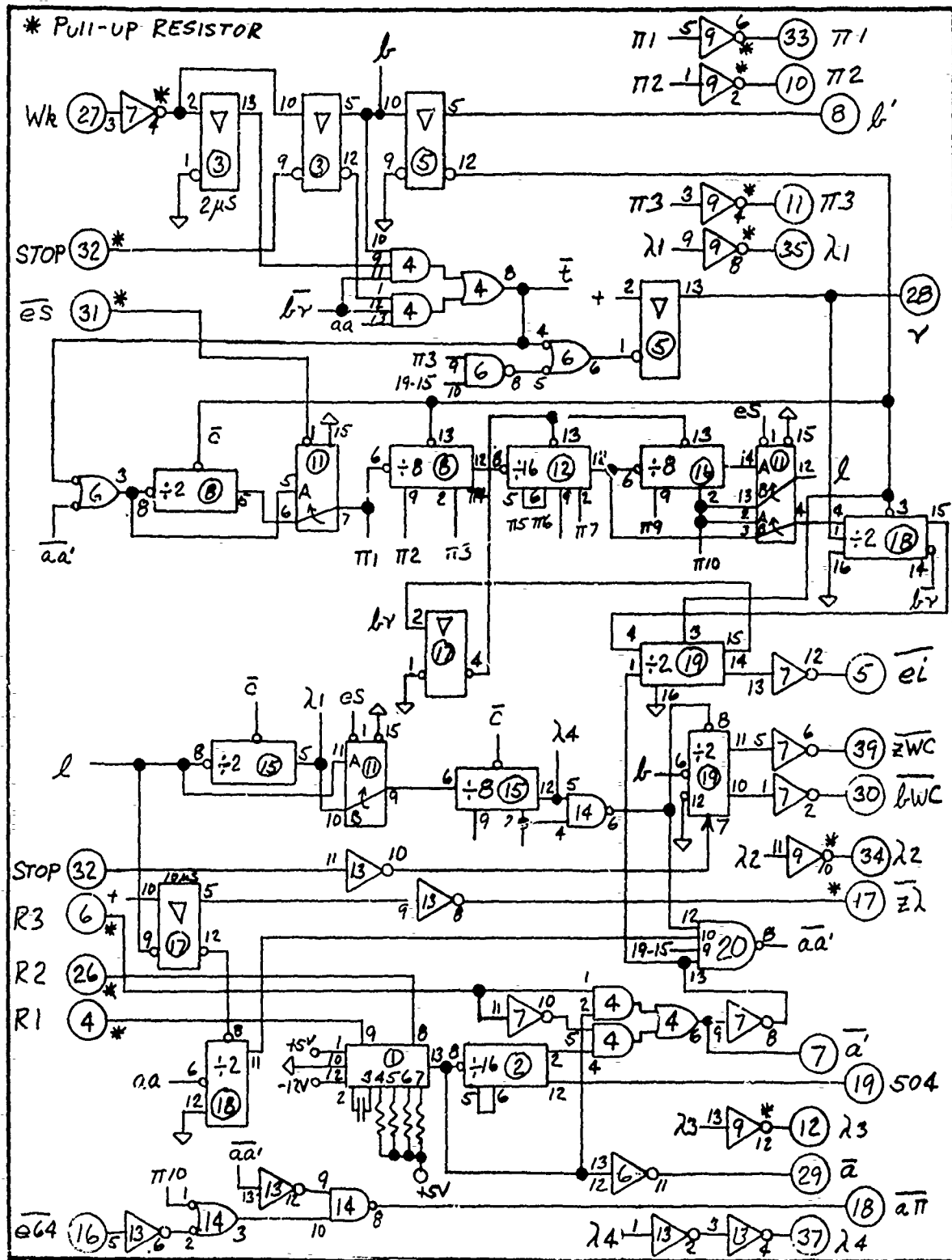

TIMER M1

7502 120

FIGURE 12

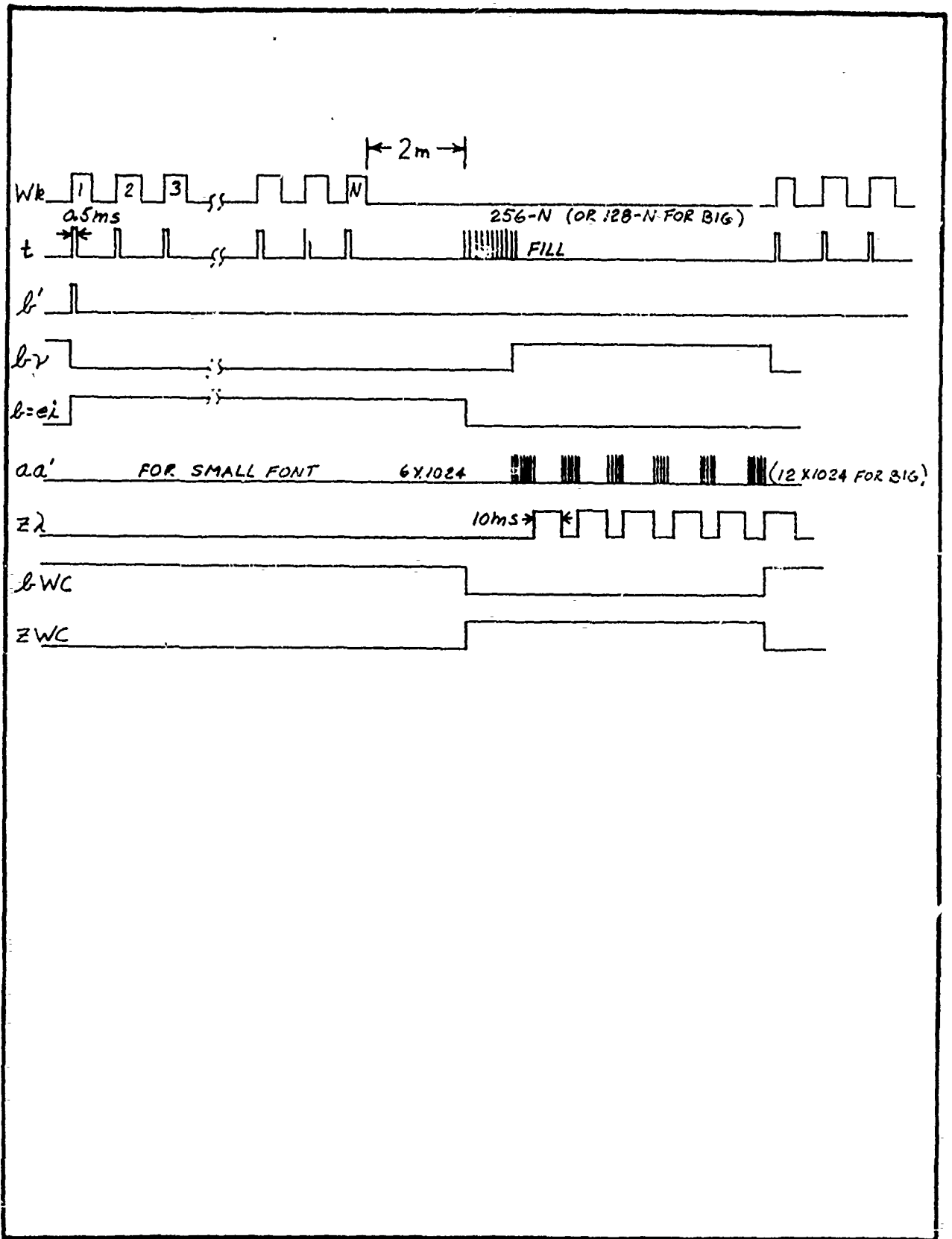

TIMING DIAGRAM

7502 121

FIGURE 13

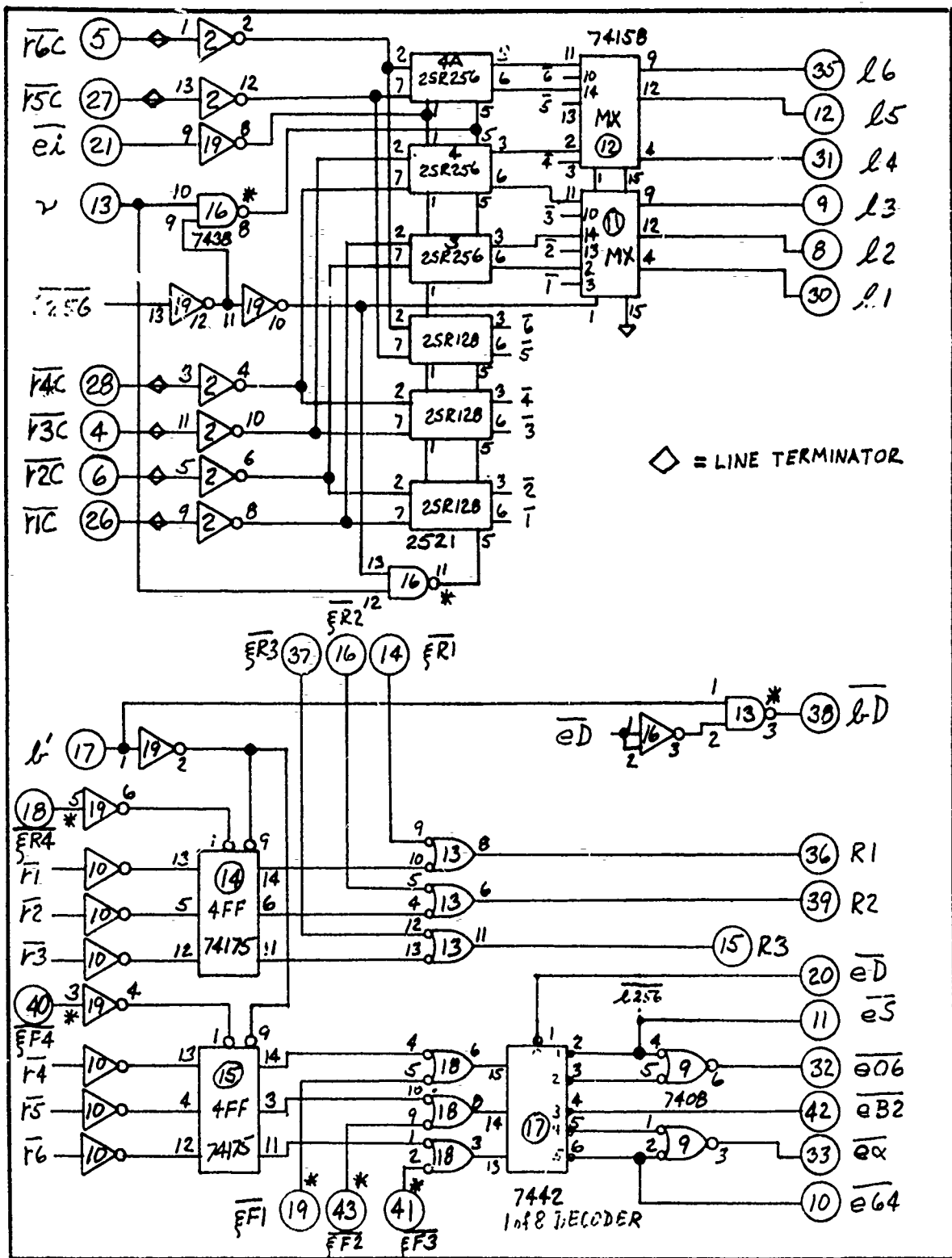

SCANNER M2

7502 130

FIGURE 14



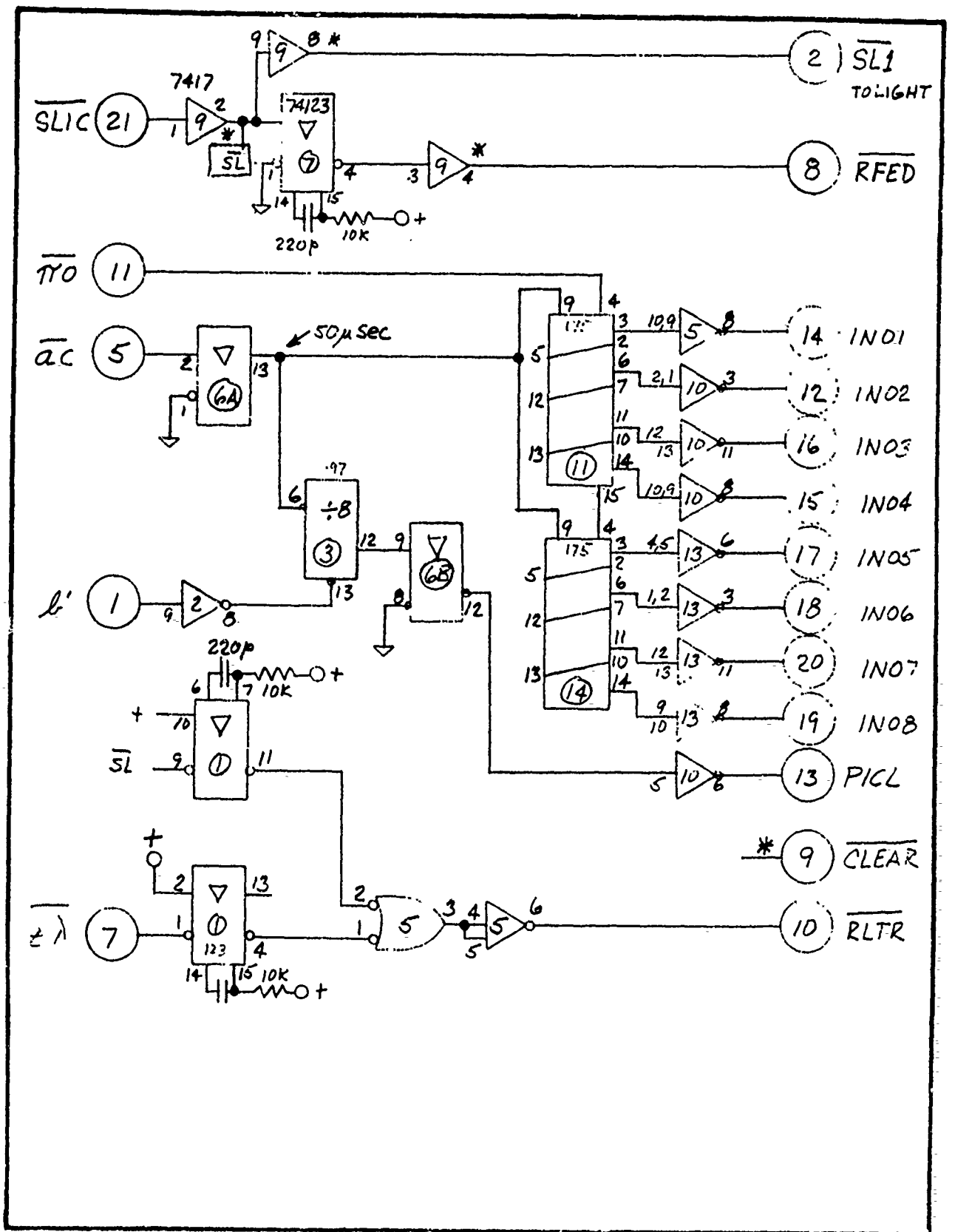

VERSATEC CONTROL M4

FIGURE 16

## 8.0 SUMMARY

The mobility of the Digisonde system made it possible to carry out ionospheric observations at widely separated locations. Because of the use of digital techniques the system was rapidly adapted to different tasks: ionogram observations, ionospheric drift and seascatter measurements. The scientific results obtained under this project lead to a number of publications. Digital data processing techniques were developed which will find application in other geophysical research.