

AD-A021 941

ESKIMO III. MAGAZINE SEPARATION TEST

Frederick H. Weals

Naval Weapons Center

Prepared for:

Department of Defense Explosives Safety Board

February 1976

DISTRIBUTED BY:

**NTIS**

National Technical Information Service  
U. S. DEPARTMENT OF COMMERCE

083138

NWC TP 5771

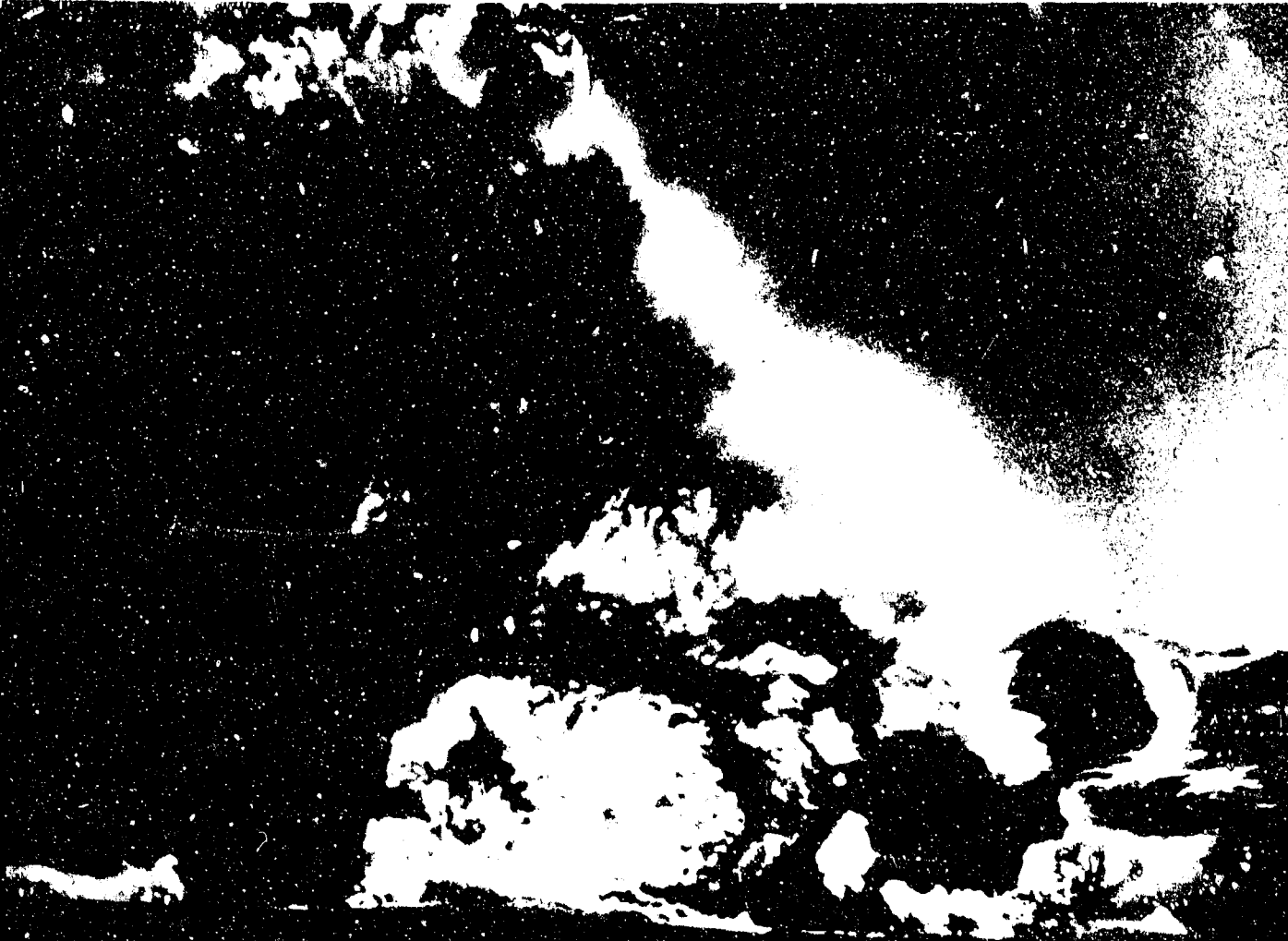

ADA021941

Eskimo III  
Magazine Separation Test

by  
Frederick H. Weals

*Test and Evaluation Department*

FEBRUARY 1976

Approved for public release; distribution unlimited.

**Naval Weapons Center**

CHINA LAKE, CALIFORNIA 93555

**Department of Defense  
Explosives Safety Board**

WASHINGTON, D.C. 20334

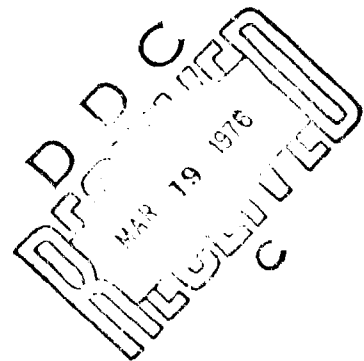

REPRODUCED BY  
NATIONAL TECHNICAL  
INFORMATION SERVICE  
U.S. DEPARTMENT OF COMMERCE  
SPRINGFIELD, VA 22161

# Naval Weapons Center

AN ACTIVITY OF THE NAVAL MATERIAL COMMAND

R. G. Freeman, III, RAdm., USN ..... Commander  
G. L. Hollingsworth ..... Technical Director

---

## FOREWORD

This report describes a full-scale magazine separation test conducted at the Naval Weapons Center in June 1974. The test work was conducted for the Department of Defense Explosives Safety Board (DDESB) using funds provided by that organization. The work was identified by Army Program Element Number 6.57.02.A and Project and Task Area Number 4A765702M857.

Based on data derived from the test, DDESB has made significant gains in information relating to hazards criteria.

Appendix B of the report, covering vehicle and traffic route investigations and window glass hazard studies, was prepared by E. R. Fletcher, D. R. Richmond, and D. W. Richmond of the Lovelace Foundation for Medical Education and Research, Albuquerque, N.M.

This report has been reviewed for technical accuracy by DDESB staff members Mr. Russell G. Perkins and Dr. Thomas A. Zaker. Mr. Perkins and Dr. Zaker also played major roles in the design of the test.

Captain Peter F. Klein, USN, Chairman of DDESB, provided technical, administrative, and policy guidance during the preparation, execution, and reporting of the test.

Released by  
J. L. REED, Head  
Project Engineering Division  
7 November 1975

Under authority of  
W. R. HATTABAUGH, Head  
Test and Evaluation Department

NWC Technical Publication 5771

Published by the Naval Weapons Center, Technical Information Department  
Collation ..... Cover, 36 leaves  
First printing ..... 100 unnumbered copies

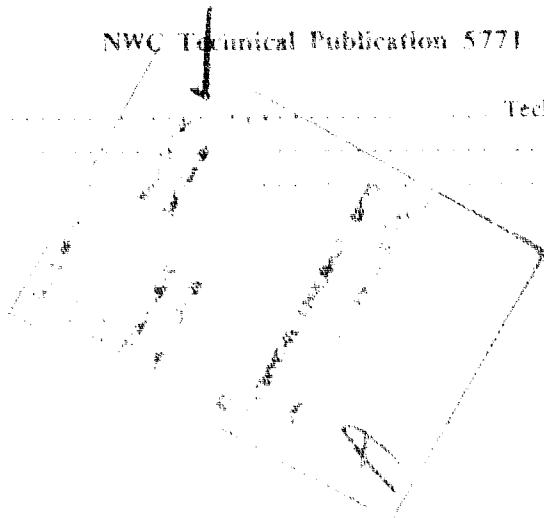

UNCLASSIFIED

SECURITY CLASSIFICATION OF THIS PAGE (When Data Entered)

REPORT DOCUMENTATION PAGE		READ INSTRUCTIONS BEFORE COMPLETING FORM
1. REPORT NUMBER NWC TP 5771	2. GOVT ACCESSION NO.	3. RECIPIENT'S CATALOG NUMBER
4. TITLE (and Subtitle) ESKIMO III MAGAZINE SEPARATION TEST	5. TYPE OF REPORT & PERIOD COVERED A test report	
	6. PERFORMING ORG. REPORT NUMBER	
7. AUTHOR(s) Frederick H. Weals	8. CONTRACT OR GRANT NUMBER(s)	
9. PERFORMING ORGANIZATION NAME AND ADDRESS Naval Weapons Center China Lake, CA 93555	10. PROGRAM ELEMENT, PROJECT, TASK AREA & WORK UNIT NUMBERS 6.57.02.A 4A765702M857	
11. CONTROLLING OFFICE NAME AND ADDRESS Department of Defense Explosives Safety Board Washington, DC 20314	12. REPORT DATE February 1976	
	13. NUMBER OF PAGES 70	
14. MONITORING AGENCY NAME & ADDRESS (if different from Controlling Office)	15. SECURITY CLASS. (of this report) UNCLASSIFIED	
	15a. DECLASSIFICATION/DOWNGRADING SCHEDULE	
16. DISTRIBUTION STATEMENT (of this Report) Approved for public release; distribution unlimited.		
17. DISTRIBUTION STATEMENT (of the abstract entered in Block 20, if different from Report)		
18. SUPPLEMENTARY NOTES		
19. KEY WORDS (Continue on reverse side if necessary and identify by block number) Detonation Tests, Eskimo III      Igloo Structures, Test of Eskimo III      Instrumentation Explosives Hazards Test      Magazine Separation Test		
20. ABSTRACT (Continue on reverse side if necessary and identify by block number) See back of form.		

DDC  
APPROVED  
MAR 19 1976  
UNCLASSIFIED

UNCLASSIFIED

SECURITY CLASSIFICATION OF THIS PAGE(When Data Entered)

(U) *ESKIMO III Magazine Separation Test*, by Frederick H. Weals. China Lake, Calif., Naval Weapons Center, February 1976. 70 pp. (NWC TP 5771, publication UNCLASSIFIED.)

(U) In an instrumented test in June 1974 at the Naval Weapons Center, approximately 350,000 pounds of Tritonal explosive contained in M117 bombs were detonated simultaneously within a steel-arch, earth-covered igloo flanked by two adjacent igloos and near three other igloos located with varying degrees of face-on exposure and at varying distances from the donor blast. The principal objective was to qualify the oval steel arch igloo at the minimum side-to-side spacing now permitted for standard earth-covered magazines. Test results indicated that the range tolerated by the oval steel arch igloo covers the minimum standard distance in feet equal to  $1.25 \times W^{1/3}$ , in which W is the weight in pounds of the high explosive in storage.

(U) Additionally, the results showed the single-leaf sliding door to be effective whether mounted on a new structure or on an existing headwall. The test also included investigation of the response of a new light-gauge, deeply corrugated steel arch and further investigation of separation distance standards, of safety distances specified for public traffic routes, and of the hazards associated with window glass used in commercial and institutional buildings. The report contains data on igloo damage and structural motion, air blast pressures at the site, and vehicle and window damage.

UNCLASSIFIED

SECURITY CLASSIFICATION OF THIS PAGE(When Data Entered)

## CONTENTS

Introduction .....	3
Test Objectives .....	4
Near-Field Test Layout .....	4
Donor Charge and Magazine .....	4
Igloos .....	5
Far-Field Test Layout .....	6
Window Test Structures .....	6
Vehicles .....	7
Aircraft .....	7
Instrumentation .....	7
Pressure Gauge Layout in the Near Field .....	7
Far-Field Pressure Gauges .....	9
Dynamic Measurement of Igloo Steel Arch Motion .....	9
Measurement of Automobile Motion .....	11
Zero Time Indicator .....	13
Photo-Optical Coverage .....	13
Timing .....	13
ESKIMO III Detonation .....	13
Test Results .....	14
General .....	14
Observed Structural Response .....	16
Data Derived From Instrumentation .....	26
Blast Pattern .....	26
Event Times .....	29
Motion Picture Photography .....	32
Blast Gauge Data .....	33
Static Measurements of Igloo Arches and Headwalls .....	38
Conclusions .....	45
Appendices .....	
A. Construction Information .....	46
B. Airblast Effects on Windows in Buildings and Automobiles on the ESKIMO III Event .....	51

## INTRODUCTION

At the request of the Department of Defense Explosives Safety Board (DDESB), the Naval Weapons Center (NWC) on 12 June 1974 conducted at the Randsburg Wash Test Range a large-scale explosives hazards test known as ESKIMO III. (ESKIMO is an acronym for Explosive Safety Knowledge Improvement Operation.) This was the third in a series of full-scale tests of earth-covered magazines sponsored by the DDESB. The main purpose of this test was to evaluate a new earth-covered noncircular corrugated steel arch magazine by exposing it to explosion of an adjacent magazine at the minimum side-to-side spacing now permitted by standards.

ESKIMO I, the first test, was conducted in December 1971 to determine a safe, practicable minimum separation distance for face-on exposures of U.S. Army standard steel-arch magazines.<sup>1</sup> Explosion communication occurred to an acceptor igloo of this design at a distance in feet equal to  $1.25 \times W^{1/3}$ , in which  $W$  is the weight in pounds of the high explosive in storage, but failed to occur at a distance of  $2.0 \times W^{1/3}$  to the rear of the donor. Further, the test revealed that safety and economy might be increased through improved design for closer balance in strength between the doors and headwall of the magazine.

ESKIMO II was conducted in May 1973 to appraise magazine door and headwall designs.<sup>2</sup> The test reaffirmed the need to balance the strength of headwalls and doors. A large, single-leaf sliding door withstood the blast with minor distortion, although the accompanying headwalls sustained severe damage. A Stradley-type headwall, on the other hand, incurred only minor damage. In addition, the noncircular (oval) steel arch tested with the Stradley headwall withstood the blast without breakup or severe distortion.

ESKIMO III further extended the study of explosive-storage magazines, using information derived from ESKIMO I and II. A further test of the oval arch and Stradley-type headwall, ESKIMO III used structures remaining from ESKIMO II, rebuilt as necessary, as well as new construction. Igloo B, the oval-arch magazine tested in ESKIMO II, was fitted with a newly designed Stradley-type headwall with a single-leaf sliding door. ESKIMO II had proven that the Stradley-type headwall could withstand a face-on impulse of 1,750 psi/msec and that the oval steel arch igloo could withstand the face-on impulses generated by that charge. ESKIMO III tested the ability of the new headwall to withstand the side-on blast imposed by the explosion of an adjacent magazine.

This report discusses ESKIMO III, its objectives, procedures, and results, and the conclusions drawn from these results.

<sup>1</sup> Naval Weapons Center, *ESKIMO I Magazine Separation Test*, by Frederick H. Weals, China Lake, Calif., NWC, April 1973, 84 pp. (NWC TP 5430, publication UNCLASSIFIED.)

<sup>2</sup> Naval Weapons Center, *ESKIMO II Magazine Separation Test*, by Frederick H. Weals, China Lake, Calif., NWC, September 1973, 90 pp. (NWC TP 5557, publication UNCLASSIFIED.)

## TEST OBJECTIVES

The primary objective was to qualify the oval steel arch igloo at the  $1.25 \times W^{1/3}$  minimum side-to-side spacing now permitted for the semicircular and other standard earth-covered magazines. Other objectives were

1. Evaluation of a less expensive light-gauge, deeply corrugated earth-covered arch.
2. Test of single-leaf sliding door installed on an existing standard headwall (Igloo C) at  $2.75 \times W^{1/3}$ , the recommended distance for face-to-side orientation.
3. Further investigation of separation distances at other than side-to-side orientation.
4. Investigation of hazards associated with window glass located at varying distances (based on U.S. and NATO inhabited-building distances) from the exploding magazine.
5. Evaluation of blast damage to highway vehicles placed at distances from magazine structures specified by the United States and NATO for public traffic routes.

## NEAR-FIELD TEST LAYOUT

### DONOR CHARGE AND MAGAZINE

The donor charge, consisting of 350,000 pounds of Tritonal contained in stacked M117 bombs, was enclosed in an earth-covered magazine, 80 feet long, which was constructed of lightweight, 14-gauge, deeply corrugated steel in place of the standard 1-gauge corrugated metal (Figure 1) but

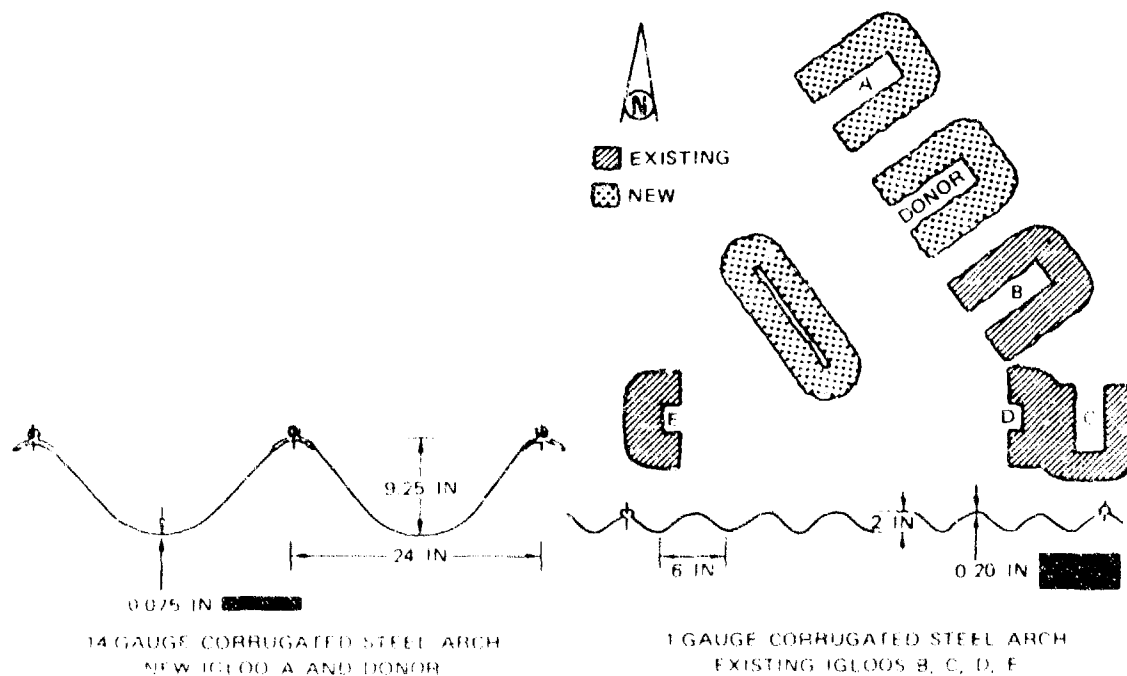

FIGURE 1. Steel Arch Plate Construction for ESKIMO III Igloos.

which was otherwise identical to the standard steel arch igloo. Appendix A presents further construction information. The donor magazine was built parallel to the oval steel arch Igloo B and at the minimum standard spacing from it.

### IGLOOS

Five acceptor magazines were grouped around the donor magazine, as shown in Figure 2. All magazines were earth-covered corrugated steel arches. Igloo A, a 14-gauge, deeply corrugated semicircular arch built to the same specifications as the donor magazine, was located at the minimum

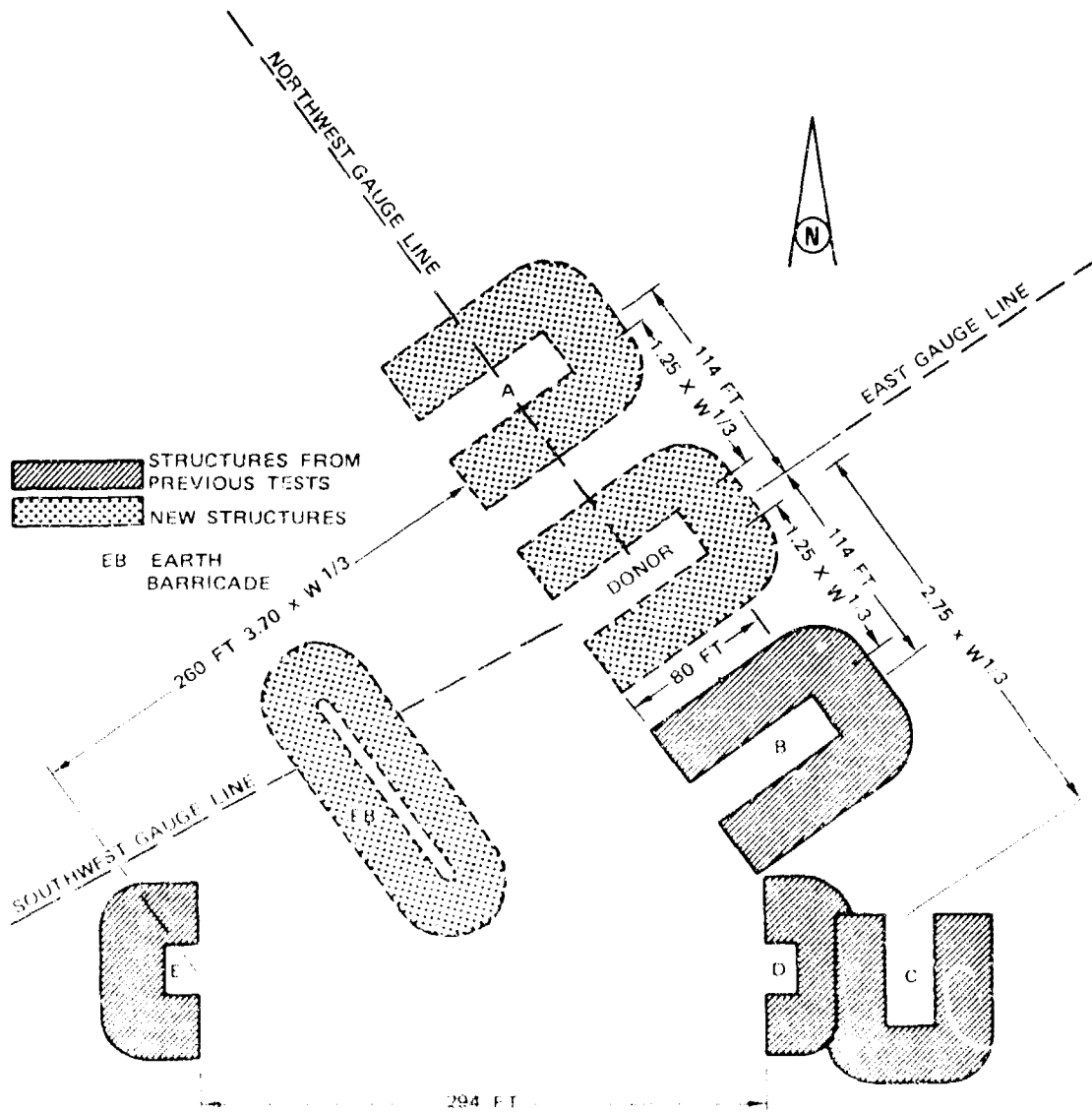

FIGURE 2. Layout of Test Structures for ESKIMO III Magazine Separation Test. A, B, C, D, and E indicate acceptor igloo destinations.

side-to-side spacing now permitted by DDEFB standards,  $1.25 \times W^{1/3}$ , from the donor. Igloo B, the existing 80-foot-long noncircular arch adjacent to the donor magazine, was equipped with a modified Stradley-type headwall and single-leaf door.

In addition, three existing standard heavy steel semicircular arches at other orientations were equipped with new doors or headwalls and doors. Acceptor Igloo C, which remained from a 1963 test, was almost exactly  $2.75 \times W^{1/3}$  feet from the donor—the recommended face-to-side separation distance. Thus it afforded the opportunity for a direct test of the improved single-leaf sliding door mounted on a sound, existing standard headwall. Igloo D, left from ESKIMO II, was rebuilt with a standard headwall and doors. Despite some line-of-sight exposure of donor and acceptor headwalls, this relative orientation qualifies for the side-to-side separation distance ( $1.25 \times W^{1/3}$ ) but is nearly at the limit of angular position beyond which the face-to-side distance ( $2.75 \times W^{1/3}$ ) applies. As built, this exposure is at  $2.55 \times W^{1/3}$ , a value between the two; a success would have justified considering some further relaxation of the standards, at least on a special-case basis. Igloo E was also rebuilt with standard doors and a standard headwall. This was a front-to-front exposure at  $3.70 \times W^{1/3}$  for the recommended size of igloo donor. Standards require  $6 \times W^{1/3}$  using a barricade of adequate height to stop fragments between igloos. This orientation was tested in ESKIMO I, with failure at  $2 \times W^{1/3}$ . The ESKIMO III test involved a separation midway between this and the untested standard distance. A success would have indicated the possibility of a worthwhile reduction of the required distance for igloos and for substantial above-ground magazines or strengthened operating buildings as well.

## FAR-FIELD TEST LAYOUT

To compile additional data regarding appropriate separation distances between explosive storage and handling sites and inhabited buildings and public highways, window test structures, motor vehicles, and a B-29 aircraft were placed at varying distances from the blast. These distances included the United States and NATO inhabited building and public traffic route distances. For the placement of these structures and vehicles, see Appendix B.

## WINDOW TEST STRUCTURES

Ten room-size wood frame cubes (used in the ESKIMO II test) were installed along the northwest radial at distances of 3,525, 3,950, and 5,920 feet from the donor blast center. On each cube windows were mounted in the wall facing the donor site. Nine of the 10 cubes were equipped with Styrofoam witness plates (glass fragment traps), provided under contract by the Lovelace Foundation for Medical Education and Research, Albuquerque, N.M. One of the cubes, positioned at 3,525 feet from the donor, contained an anthropomorphic dummy provided by the Lovelace Foundation. The responses of the dummy and the window in front of it were recorded by an NWC

16-mm camera operating at approximately 400 frames per second. Window test cubes had been constructed, sited, installed, and fitted with accessories in accordance with NWC Dwg. IR No. 7-4777/A-1 A-2, Shop Control W057-282.

For information on test results for these structures, see Appendix B.

## VEHICLES

Ten automobiles were exposed to the blast, at ranges of 2,115 feet (U.S. public highway separation distance), 2,620 feet (NATO separation distance), and 3,950 feet (1.5 times the NATO distance) (see Appendix B).

One of the vehicles that was located at 2,115 feet contained an anthropomorphic dummy, secured by means of a lap seat belt. A second high-speed 16-mm camera recorded the responses of this dummy and the automobile windows adjacent to it.

Appendix B discusses the responses of all vehicles to the test.

## AIRCRAFT

The B-29 aircraft, which was located 1,800 feet from the donor in the ESKIMO I test, was moved to 1,210 feet from the donor for the ESKIMO II test. For ESKIMO III, the aircraft remained in position, about 1,100 feet from the new donor.

## INSTRUMENTATION

### PRESSURE GAUGE LAYOUT IN THE NEAR FIELD

Incident peak overpressure versus time was recorded at the ground surface 2 feet in front of each acceptor igloo. Reflected peak pressure and impulse load were obtained directly from face-on blast gauges set in each headwall just outside the spring line of the metal arch and about 4 feet above the floor level of the magazine. A row of surface gauges was emplaced to measure the incident peak pressure over the earth on the light-gauge circular arch magazine (Igloo A), on the oval arch magazine (Igloo B), and to the rear of the donor magazine. Figure 3 illustrates the locations of these Kistler piezoelectric gauges.

Token explosive charges were not used in the acceptor igloos as indicators of explosive communication. Rather, acceleration and displacement measurements were made on the arches of Igloos A and B to determine the degree of risk to explosive contents in case of a failure of one of the magazines.



## FAR-FIELD PRESSURE GAUGES

Twenty Ballistic Research Laboratories (BRL) self-recording mechanical gauges were placed (Table 1) in pairs at 660 and 1,320 feet from the blast site on the east radial; at 660, 1,320, 2,115, and 2,630 feet on the southwest radial; and at 660, 1,320, 2,115, 2,630, and 3,526 feet on the northwest radial. At positions also designated for vehicles or window test cubes, gauges were carefully placed where they would not be shielded from the blast.

TABLE 1. Schedule of Capsule Selections  
for BRL Self-Recording Gauges.

Radial distance from donor, ft	No. of gauges NW leg	No. of gauges SW leg	No. of gauges NE leg	Est. max overpressure, psi	Capsule rating, psi
660	2	2	2	11.0	15
1,320	2	2	2	3.5	5
2,115	2	2	...	1.9	5
2,630	...	2	...	1.3	5
2,630	2	...	...	1.0	1
3,526	2	...	...	0.7	1

## DYNAMIC MEASUREMENT OF IGLOO STEEL ARCH MOTION

Motion of the steel arch versus time was measured in Igloos A and B, using instruments described in Tables 2 and 3 and Figure 4. Absolute measurements are based on an arbitrary bench mark established outside the test area.

All measurements except accelerometer readings were based on measuring the telescoping action of a steel rod in a round tube. The action of the arch and of the rods was photographed at igloo midpoints. Total motion relative to a zero or initial position was recorded by means of a scratch device at all positions. Since the floor was also expected to be moving, measurements of arch motion were relative to a 640-pound mass, a 4-foot by 4-foot by 1-inch steel plate supported by an air-filled toroidal rubber bladder. Motion of the floor relative to this reference mass was also photographed at the midsections of Igloos A and B.

Linear motion transducers were used to measure the movement of all tubes on the 45-degree radial on the blast side of Igloo A and the corresponding tubes at 20 feet and at 60 feet from the headwall of Igloo B; on the centerline, 20 feet from the headwall, of Igloos A and B, and on the centerline, midsection, of Igloo B.

Accelerometers were installed at positions shown in Tables 2 and 3. Two acceleration components were measured in the cross-sectional plane of the magazines on the centerline, midsection, of Igloos A and B.

TABLE 2. Interior Motion Instrumentation, Igloo A.

S = scratch gauge  
 PO = photo-optical motion recording  
 LM = linear motion transducer  
 A = single-axis accelerometer  
 A-A = 3-axis accelerometer  
 (records two outputs)

Distance from door, ft	45 deg. blast side	22 1/2 deg off CL, blast side	CL, vertical	22 1/2 deg off CL, lee side	45 deg. lee side
20	S, LM	...	S, LM, A	...	S
40	S, PO, LM, A	S, PO	S, PO, A-A	S, PO	S, PO
60	S, LM	...	S, A	...	S

TABLE 3. Interior Motion Instrumentation, Igloo B.

S = scratch gauge  
 PO = photo-optical motion recording  
 LM = linear motion transducer  
 A = single-axis accelerometer  
 A-A = 3-axis accelerometer  
 (records two outputs)

Distance from door, ft	8 ft above floor, blast side	8 ft off CL, blast side	CL, vertical	8 ft off CL, lee side	8 ft above floor, lee side
20	S, LM	...	S, LM, A	...	S
40	S, PO, A	S, PO	S, PO, LM, A-A	S, PO	S, PO
60	S, LM	...	S, A	...	S

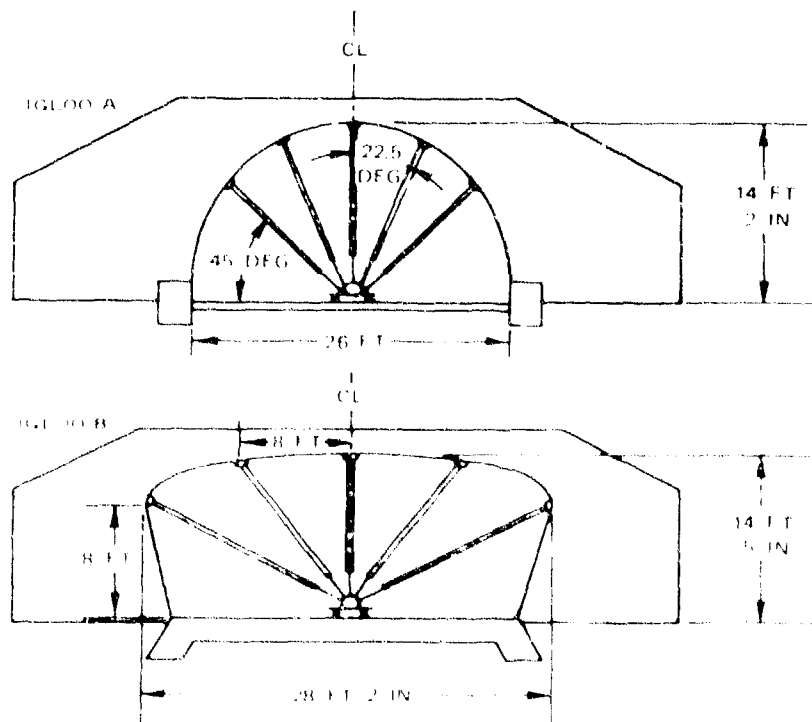

FIGURE 4. Igloos A and B. Dots - Relative Slopes and Locations of Displacement Measuring Apparatus on Each

**MEASUREMENT OF AUTOMOBILE MOTION**

Some vehicles used in ESKIMO II, but unsuitable for ESKIMO III because of prior damage, were moved to a position near the south camera station. The vehicles were turned to expose the previously unexposed side. The motion of these vehicles when hit broadside by the blast wave was then photographed.

A fixed post, intended to provide a reference for gauging car movement, was placed in the field of view of the camera photographing the dummy inside a vehicle on the northwest radial at 2,115 feet from the donor charge.

Spring-loaded styli were attached to extensions of some vehicle bodies to provide a signature of vehicle motion on a fixed aluminum sheet rigidly attached to the ground. Figure 5 represents the actual size records from these scratch gauges.

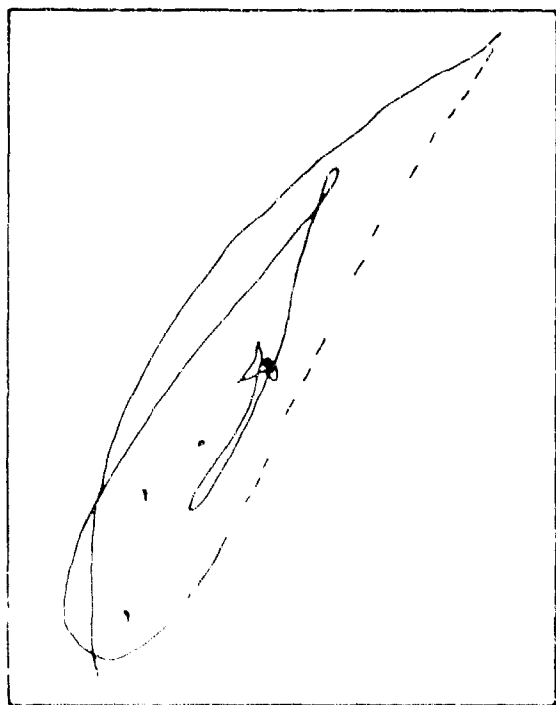

(a) 2,115 feet, Dodge station wagon

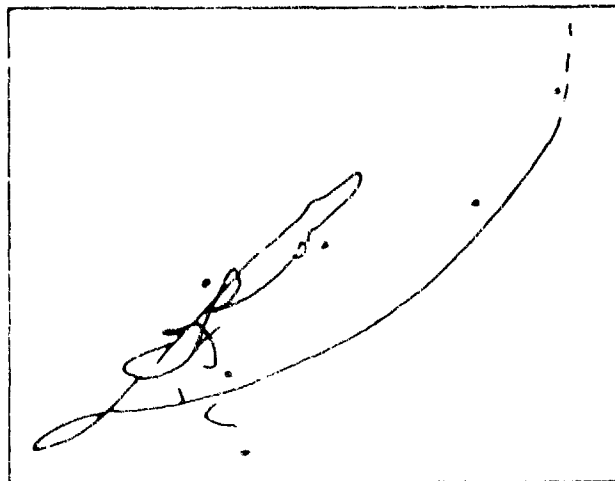

(b) 2,115 feet, Rambler

FIGURE 5. Vehicle Motion Signatures, Actual Size

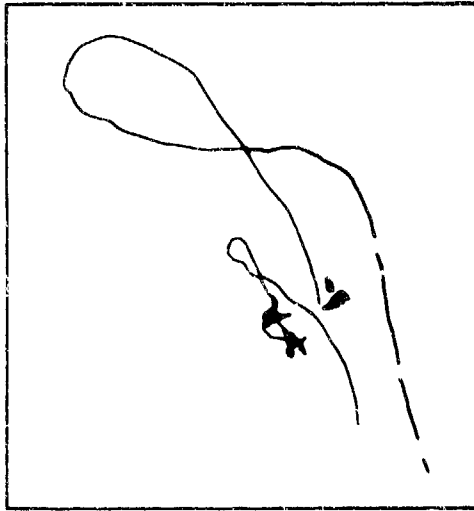

(c) 2,115 feet, Buick station wagon.

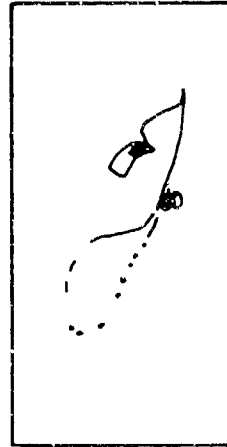

(d) 2,115 feet, defauler.



(e) 2,115 feet, VW bug.

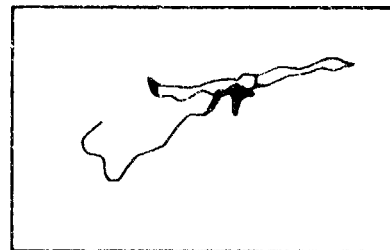

(f) 2,630 feet, VW station wagon.

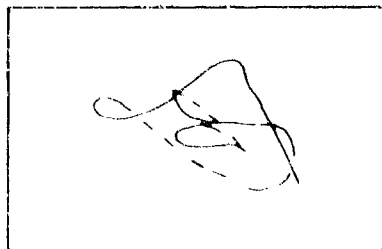

(g) 2,630 feet, Chevrolet station wagon.

FIGURE 5. (Contd.)

## ZERO TIME INDICATOR

Zero time or time of detonation for the M117 bombs was determined by the recorded signature of ionization probes placed within the donor stack.

## PHOTO-OPTICAL COVERAGE

Photographic coverage of the test was recorded by 14 high-speed 16-mm cameras, at speeds from 400 to 4,000 frames per second, and two slower 35-mm cameras running at 120 frames per second. Four of the 16-mm cameras provided interior coverage of acceptor igloo doors; two more 16-mm cameras recorded the action of the telescoping motion sensors in Igloos A and B. All interior footage was shot at 400 frames per second.

Three of the cameras covering the site area and oblique views of the headwalls were located 1,500 feet south of the donor. A fourth camera at this location recorded the motion of the cars left from ESKIMO II. Also at 1,500 feet, but west-southwest of ground zero, another camera recorded the blast face-on. A camera located on top of the instrumentation barricade 950 feet west of ground zero provided a more localized record of the donor and Igloo A. Four 16-mm Milliken cameras were located on the northwest radial: two at 2,115 feet (one recorded at close range the responses of the windows and dummy in the car; the other provided specific coverage of the donor igloo) and two at 3,525 feet (one recorded the responses of the dummy and the glass in the window test structure; the other recorded the general site and the blast).

This coverage was augmented by aerial photography, including 16-mm motion pictures at 400 frames per second and 70-mm pictures at 10 frames per second taken from a helicopter at 45 degrees elevation from the site and at 14,000 feet slant range.

## TIMING

Timing was provided on records of all near-field pressure gauges, linear motion transducers, accelerometers, and selected cameras so that the events recorded were correlatable. On the test day timing problems were encountered and corrected; however, the timing to several cameras was sacrificed to avoid further test delay.

## ESKIMO III DETONATION

At 1430 PDT on 12 June 1974, the explosion of the donor charge of stacked M117 bombs was initiated by sending an electrical firing pulse to two engineer specials placed in the bundled terminal of detonating cord. The equal length Primacord leads went to 660 bombs, almost 75% of the total number. The electrical impulse for the two detonators originated in the Randsburg Wash Fire Control Building, approximately 6 miles from the blast site.

## TEST RESULTS

### GENERAL

Based on presently available data from gauge records, it is believed that complete, or essentially complete, detonation was achieved. The blast shattered the donor magazine and produced the crater shown in Figure 6 and mapped topographically in Figure 7. Varying amounts of structural damage were incurred by the test magazines and far-field structures. Details on igloo damage are presented with illustrations in the following sections; details on far-field damage follow in Appendix B.



FIGURE 6 Donor Magazine Crater (Neg. IHI 183162)

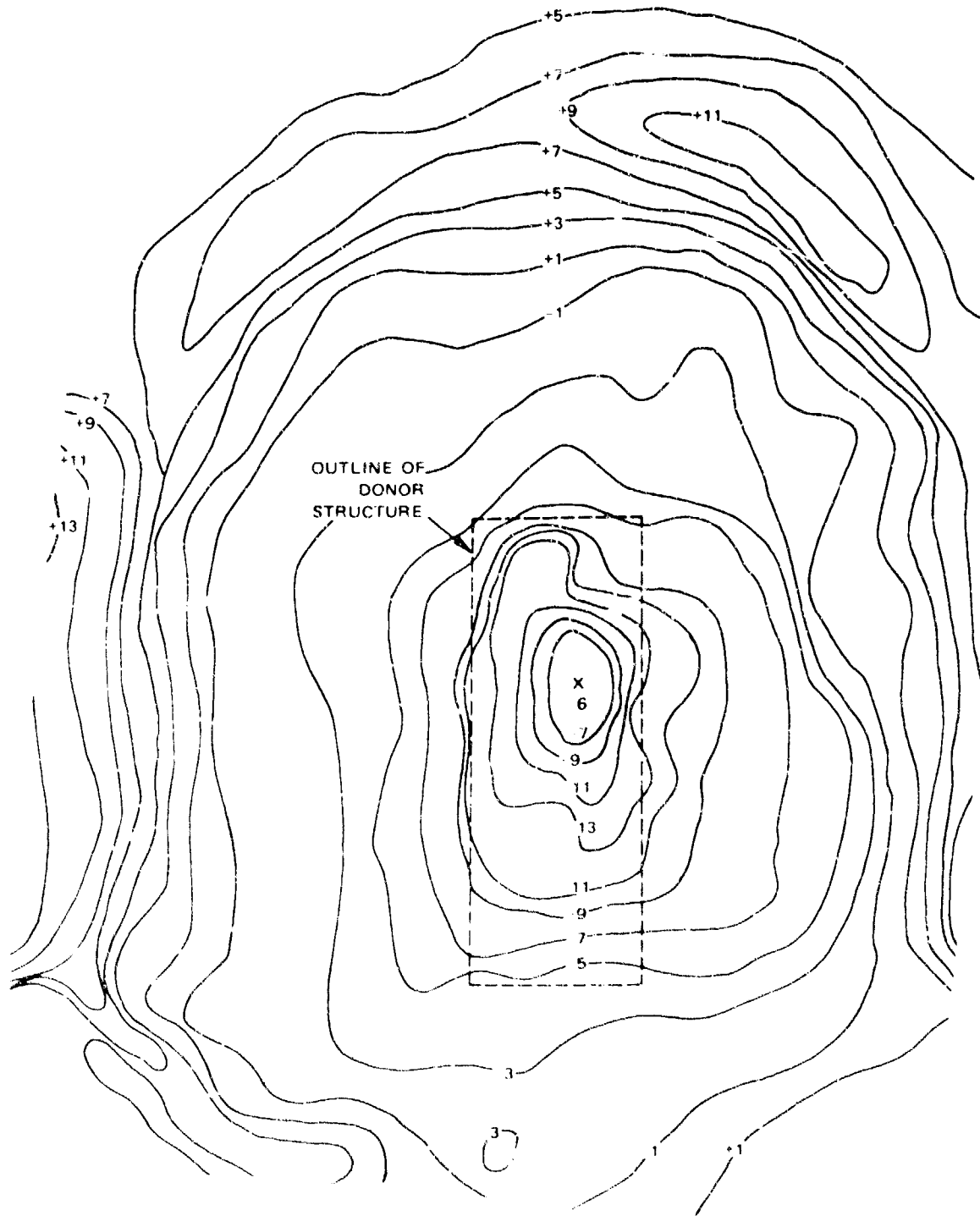

FIGURE 7. Crater Contours. The donor pool floor level was arbitrarily chosen as 0.0 height. Negative values indicate below donor floor level; positive values, a build-up.

## OBSERVED STRUCTURAL RESPONSE

### Igloo A

The deeply corrugated, 14-gauge, metal arch was deformed non-uniformly, with the deformation most pronounced along the portion of the arch nearest the center of the donor and about 7 feet above the floor line (Figures 8 and 9). Although damage to the arch on the side facing the donor made the igloo unsuitable for reuse, the arch did not collapse, and the velocity of inward movement of arch components would not have provided a hazard to explosive stores.

Both door leaves were ripped from their hinges and thrown inward with the left leaf (left as

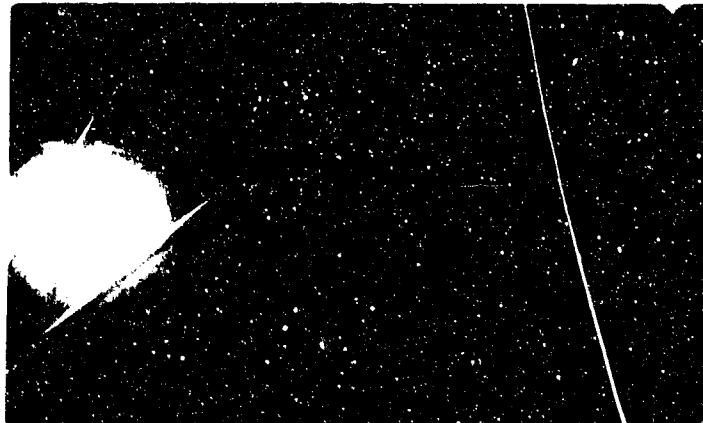

FIGURE 8. Acceptor Igloo A, Interior View of Side Nearest the Donor Magazine. (Neg. THH 183189)



FIGURE 9. Acceptor Igloo A, Interior View of Side Nearest Donor Magazine. (Neg. THH 183189)

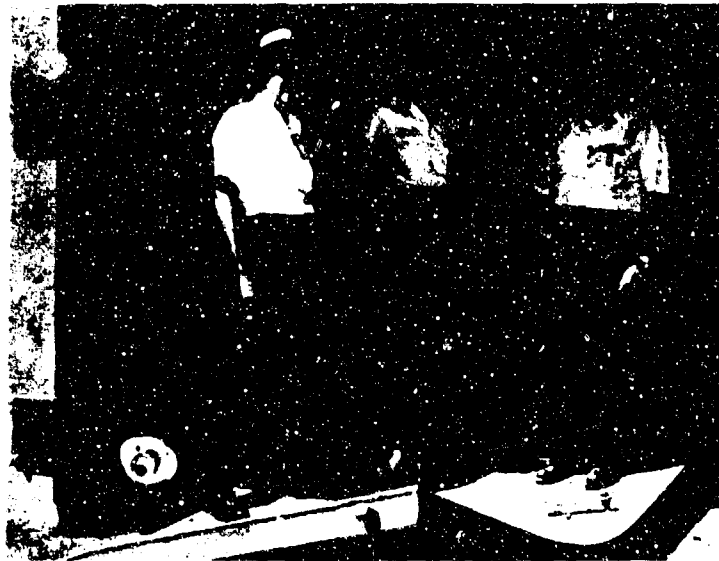

FIGURE 10. Official Visitors to the Test Standing on Right Leaf of Door to Acceptor Igloo A. (Neg. IHL 183160)

viewed by an observer on the outside and facing the magazine door) coming to rest in a near vertical position, lodged between the igloo arch and floor. The right leaf came to rest in the igloo doorway with the exterior face up (Figure 10).

### Igloo B

The noncircular steel arch approximating the Stradley magazine configuration experienced only minor structural damage (Figure 11). The outward-sloping corrugated metal sidewalls were pushed inward slightly, with the maximum deformation occurring at a height of 4.5 to 5.0 feet above the floor at the side nearest the donor blast. The floor bowed upward, with the maximum movement occurring along the centerline. Upward movement at the centerline was typically near 0.3 foot. The central flat crown of the noncircular steel arch moved outward (upward) slightly relative to the centerline of the floor, with relative movements of 0.38 foot at the midpoint of the arch. In absolute terms the upward movement at the arch above the position was 0.72 foot. Absolute movement was measured relative to an arbitrary bench mark established outside the blast area. The igloo headwall incurred significantly less apparent damage than any headwall tested to date in the FSKIMO series. The six-leaf sliding door separated from its support rail and fell on the ground immediately in front of the door opening (Figure 12). Although it fell, the door was structurally sound and is being reused in a follow up test. The door closure and locking device was pulled away from the concrete pilaster at the right hand side of the door opening, and the door support rail was damaged (Figures 13 and 14). Explosives stored within the magazine would have been well protected. It is possible that floor motion would have upset some ordnance stacking arrangements, but very unlikely that any explosive hazard would have been produced by this. A large plate glass mirror placed in the southwest corner of the magazine near the door for photographic purposes did not break.

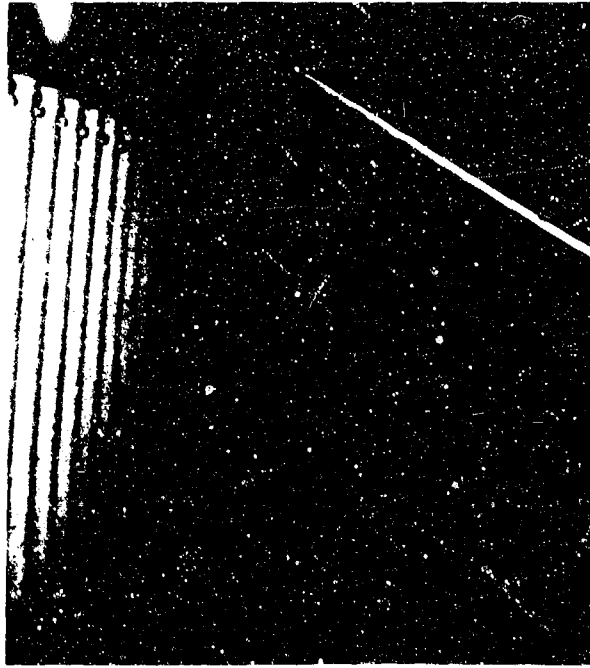

FIGURE 11. Acceptor Jeloo B, Interior of Side Nearest Donor. (See IRI 183164)



FIGURE 12. Donor, Marazion, Crater, With Acceptor Jeloo B and D in Background. Arrow indicates position of the single left door from Jeloo B. (See IRI 183163)

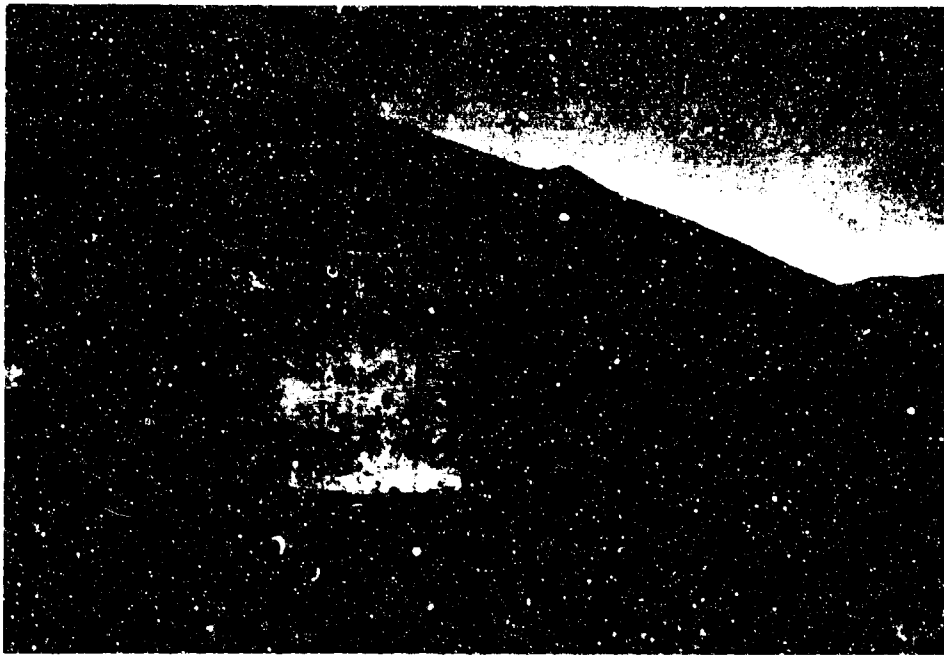

FIGURE 13. Igloo B, Right Headwall and Doorjamb. (Neg. IHI 183170)



FIGURE 14. Aqapqor Igloo B, Doorway and Left Headwall. (Neg. IHI 183169)

### Igloo C

The horizontally spanning, single-leaf sliding door, essentially identical to that used on Igloo B, withstood the blast with little apparent damage or deformation (Figure 15). It remained in place at the door opening but could not be moved until power equipment was brought to the site for door removal. The concrete headwall remaining from a 1963 test experienced some cracking (Figure 16), inward movements up to 0.40 foot, and interior concrete spalling near the door opening. The degree of headwall damage was significantly less than that experienced by a similar door and headwall combination used in the south magazine of the ESKIMO II test. The pressure levels measured at the headwall were also less for the FSKIMO III test.



FIGURE 16. A. POST-BLAST HEADWALL CONDITION (1963)



FIGURE 16. Accepter Igloo C, Headwall and Door. (Sep. THH 183166)

#### Igloo D

Igloo D experienced inward door movement with complete separation of the left door leaf through hinge failure (Figure 17). Inward rotational movement of the right door leaf resulted in severe twisting of the steel doorjamb and withdrawal of hinge plate anchor bolts at the top and middle hinge positions (Figure 18). Except for the damage at the right doorjamb, the headwall damage was generally slight (Figure 19). Limited door leaf deformation suggests that the doors did not achieve high velocities and probably would not have detonated any stored explosives.



FIGURE 17. Left Side of Doorway of Igloo D. (Neg. LHL 183171)



FIGURE 18. Right Side of Doorway of Acceptor Igloo D. (Neg. LHL 183172)



FIGURE 19. Igloo D, Doorway. (Neg. LHL 183173)

### Igloo E (Head-On)

The most severe door and headwall damage was experienced by Igloo E. Here the door-leaf damage and deformation indicated that the leaves were thrown inward with significant velocity (Figures 20, 21, and 22) and would have jeopardized any stored explosives. Additionally, the steel channel used for the left doorjamb and the door head were separated from the concrete headwall (Figure 23). The headwall experienced considerable damage, with a maximum inward movement of approximately 1.5 feet where the bottom portion of the left doorjamb separated from the floor (Figure 24).

### B-29 Aircraft

Damage to the B-29 frame, located about 1,100 feet from the blast, was extensive. An aircraft at this distance would have been damaged beyond economical repair.

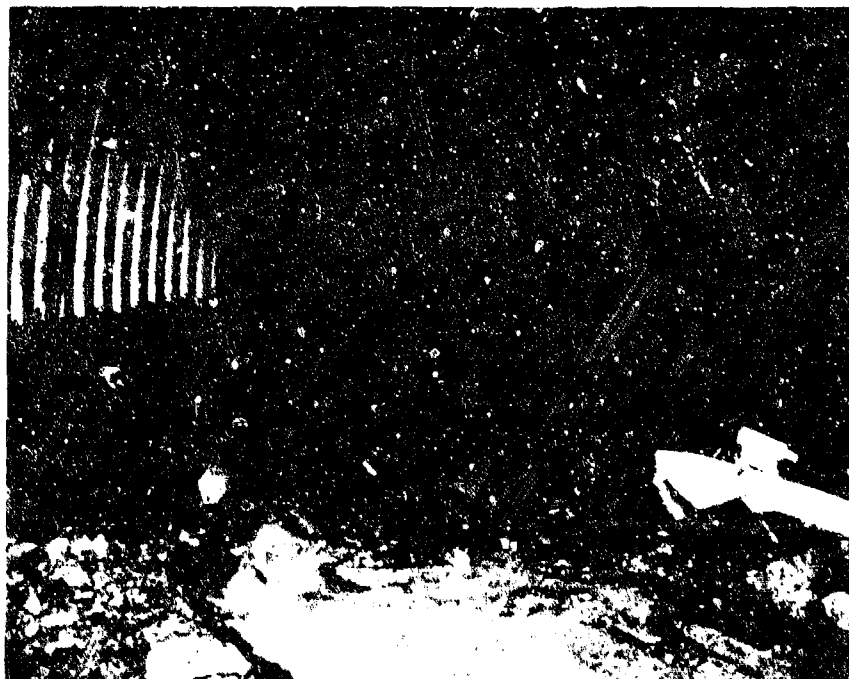

FIGURE 20. Acceptor Igloo E, Left Side Interior. (Neg. IHI 183174)

NWC TP 5771



FIGURE 21. Right Side Interior of Igloo E. (Neg. IHI 183176)



FIGURE 22. Igloo E, Left Side of Igloo. (Neg. IHI 183175)

NWC TP 5771

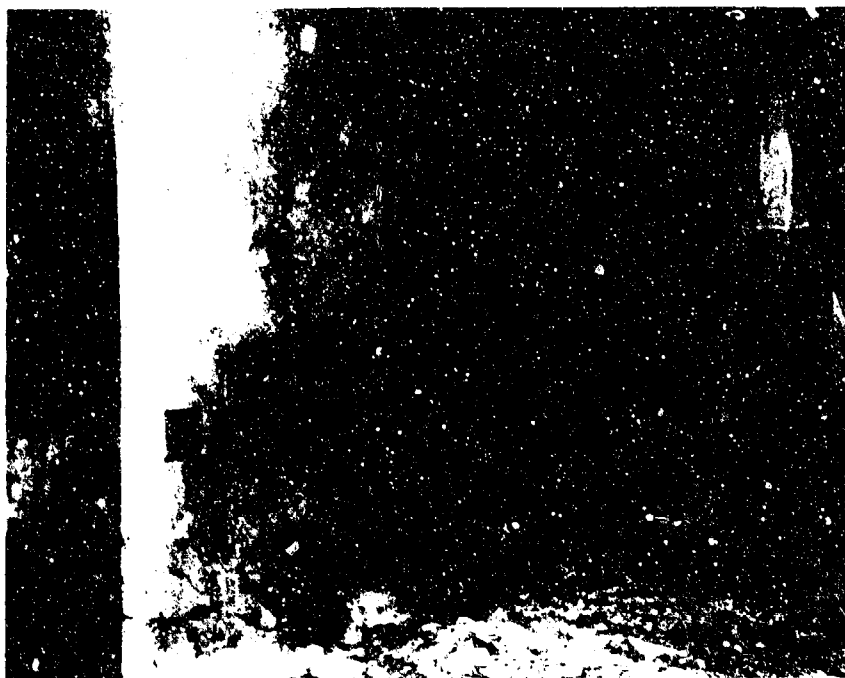

FIGURE 23. Igloo E, Headwall and Doorway. (Neg. LHL 183177)

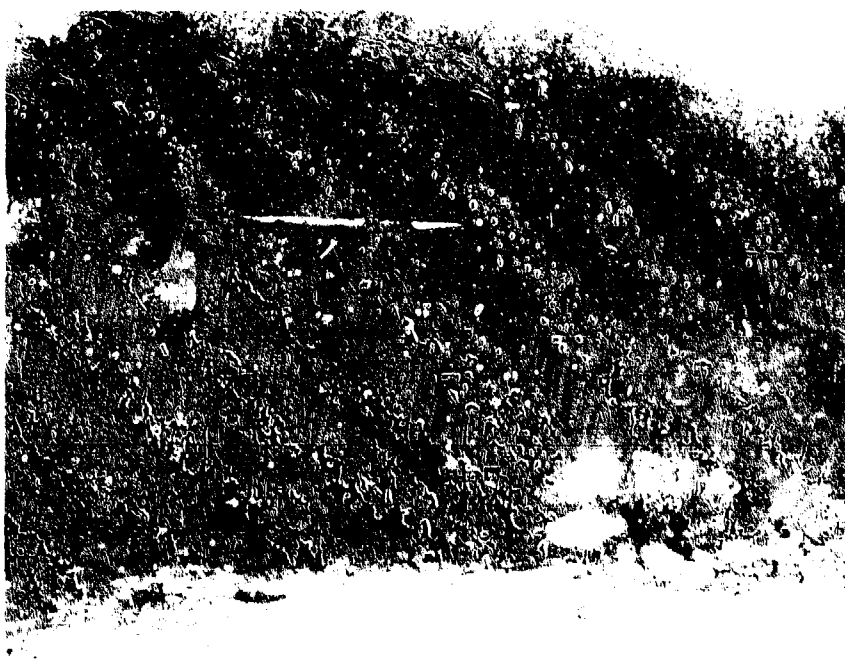

FIGURE 24. Igloo E, Doorway and Headwall. (Neg. LHL 183178)

**DATA DERIVED FROM INSTRUMENTATION**

**BLAST PATTERN**

The presence of the igloo structure and earth cover strongly influences the character of the blast wave produced by the donor charge. Figure 25 shows time-of-arrival isopleths for 50 and 90 milliseconds together with an incident overpressure isopleth for 50 psi. These isopleths have the general character of ellipses with centers on the centerline of the forward extension of the donor igloo centerline and 20 to 30 feet forward of the exterior face or 60 to 70 feet forward of the geometric center of the donor igloo. These patterns contrast with the normal circular patterns expected to occur around the donor center when the donor is unconfined. The presence of the igloo greatly reduces overpressures and impulses to the sides and rear of the igloo.

Figure 26 shows graphically the averaged overpressure data acquired in sideward directions from the donor igloo (at right angles to the longitudinal centerline) compared to expected values from an

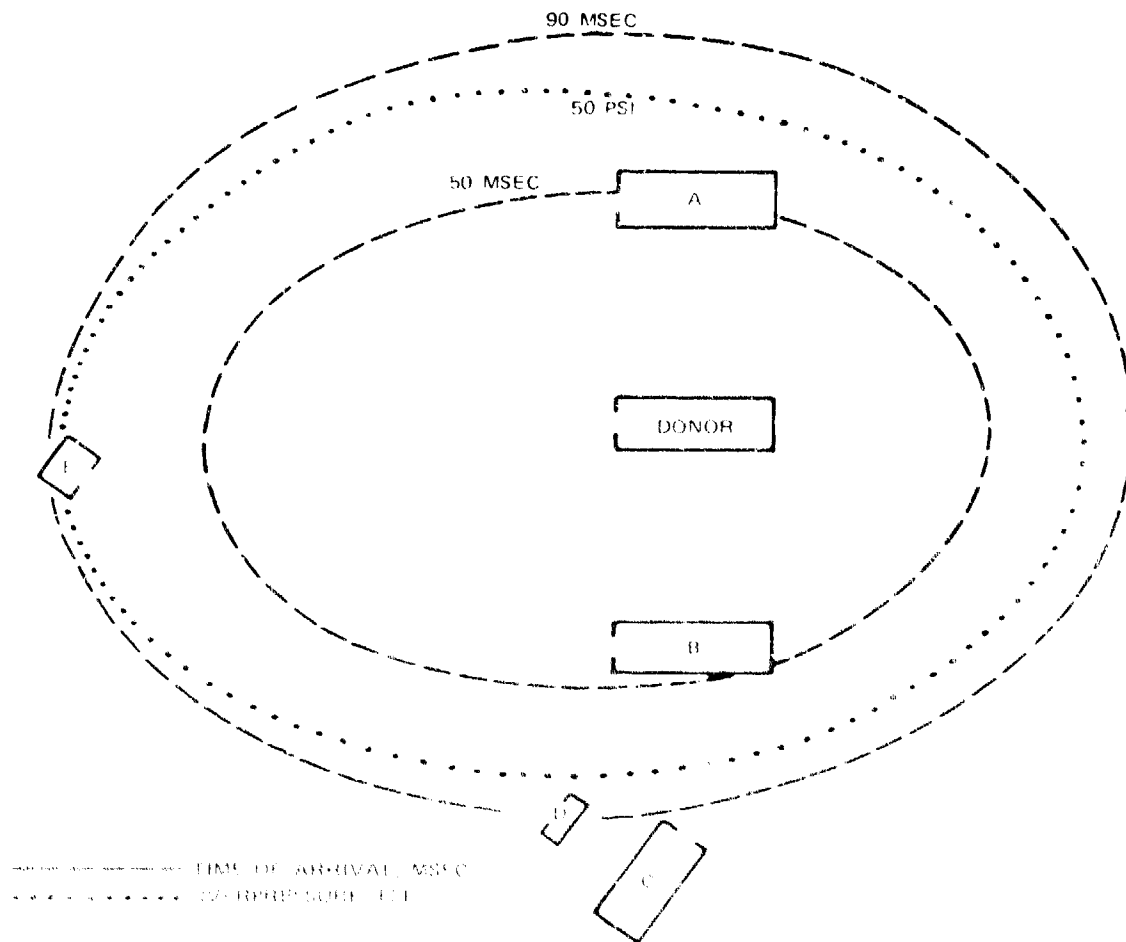

FIGURE 25. Near Field Blast Patterns.

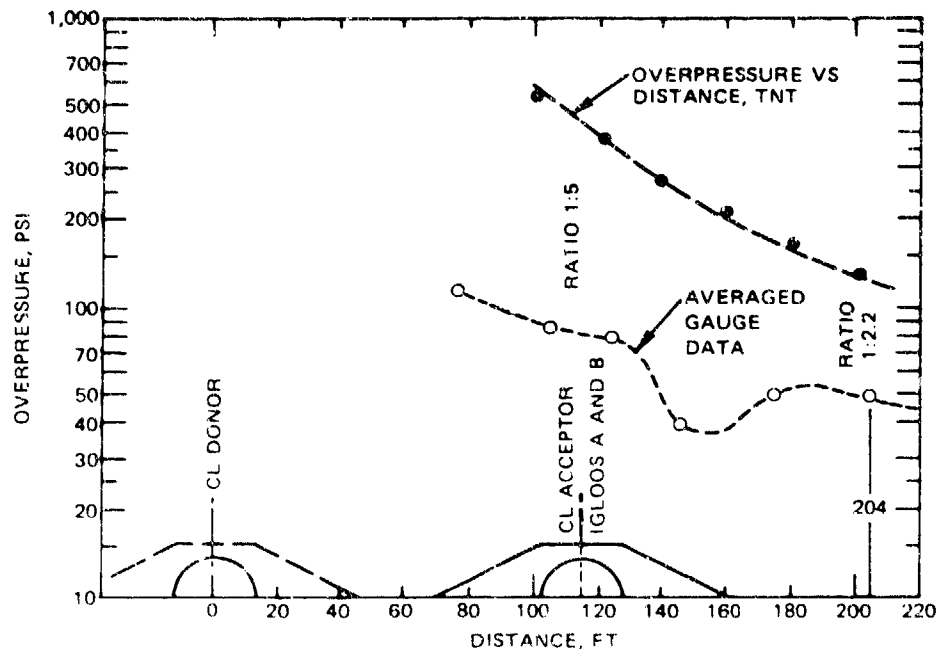

FIGURE 26. Overpressure Versus Distance in the Near Field.

equivalent weight of TNT. This shows that expected overpressures from the unconfined TNT charge are approximately five times as great as those actually experienced at a distance equal to that from the centerline of the donor structure to the centerline of acceptor igloos A and B. The ratio reduces to 1:2.2 at sideward gauge positions 204 feet from the centerline of the donor igloo. This position approximates the position of a headwall in the minimum face-to-side orientation of  $2.75 \times W^{1/3}$ . At sideward positions 1,320 feet from the donor centerline, the ratio reduces to about 1:1. These same comparisons are shown in a different form in Figure 27 which also compares a standard TNT curve with overpressures fore and aft of the donor igloo in addition to those to the sides. Figure 27 shows that blast overpressures recorded to the rear of the donor igloo remain well below standard values for an unconfined charge<sup>3</sup> at distances out to 1,320 ( $18.7 \times W^{1/3}$ ) feet and that overpressures recorded forward of the donor exceeded standard values at near-field positions ( $\approx 300$  or  $4.25 \times W^{1/3}$  feet) but dropped below standard values for 1,320 and 2,115 ( $30 \times W^{1/3}$ ) feet. Averaged overpressure and impulse data show that at 660 feet from the center of the donor, the blast approximated that from 225,000 pounds of unconfined TNT in a hemispherical configuration. The corresponding value at 1,320 feet is 255,000 pounds of TNT.

The assumed value of  $W = 298,000$ , used in Figures 26 and 27, was calculated using procedures outlined by Fugelse,<sup>4</sup> in which

$$W_{eff} = W \times F$$

<sup>3</sup>Ballistic Research Laboratories, *Air Blast Parameters Versus Distance for Hemispherical TNT Surface Bursts*, Aberdeen Proving Ground, Md. (BRL, September 1966, GRI Report No. 1344, publication UNCLASSIFIED)

<sup>4</sup>General American Transportation Corp., *Explosion Effects Computations Aids*, by L. E. Fugelse, L. M. Weiner, and J. H. Schiffman-Niles, III, GATC, June 1972. (Final Report, GARD Project No. 1540, publication UNCLASSIFIED)

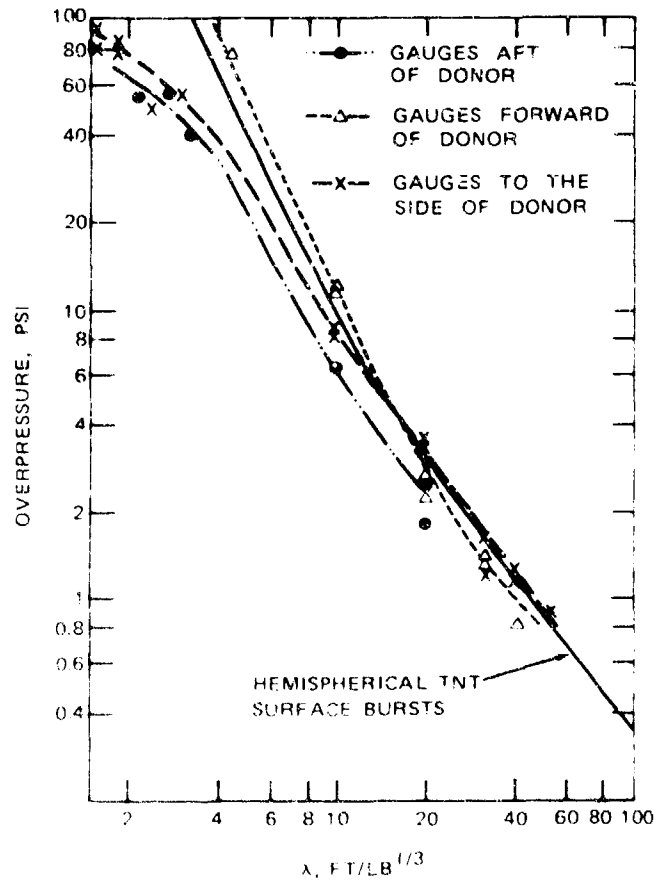

FIGURE 27. Plot of Overpressure Versus Scaled Distance (a) Compare ENKIMO III Blast Data With Standard TNT Blast Data. Assumed effective explosive weight,  $W = 295,000$  pounds.

where  $W_{eff}$  is the effective TNT equivalent weight in pounds,  $W'$  is the total charge weight of the stack in pounds of TNT, or, the total explosive weight of Tritonal times the TNT equivalency factor for Tritonal (1.13), and

$$L = 0.6 \left( \frac{0.4}{1 + 2MC} \right)$$

where  $M$  is the case weight (351 pounds), and  $C$  is the TNT equivalent of the explosive filling per unit (386 + 1.13 = 436 pounds for the M117 bomb).

Using these values,

$$W_{eff} = (350,000 + 1.13) + 0.6 \left( \frac{0.4}{1 + 2 \times 351 \times 436} \right)$$

$$295,500 \approx 0.753$$

$$297,411.8$$

## EVENT TIMES

With the exception of the BRL self-recording gauges, all data were recorded on a time base with zero time determined by a pulse indication from an ionization probe inside the donor magazine. Standard IRIG Format B was used for motion pictures, and binary coded 1,000-hertz timing was used for magnetic tape data from near-field instrumentation (piezoelectric blast gauges, linear motion transducers, and accelerometers). Table 4 summarizes early event times in the near field. Table 5 summarizes the data obtained from accelerometers. Figure 28 represents the data obtained from the accelerometer located at the front one-quarter centerline, position of Igloo A. Figure 28a shows the direct record of acceleration plotted against time; Figure 28b, the plot of a derived value of velocity versus time. Those acceleration values marked greater than 40 g in Table 5 are well beyond the calibration range of the accelerometers and, therefore, cannot be measured with any degree of confidence.

Figures 29 through 32 represent recordings of Kistler piezoelectric blast gauge data; on all four of these figures the small timing pulses are milliseconds.

TABLE 4. Summary of Event Times in Milliseconds.

Times are based on zero time identified by ionization probe inside donor magazine.

Event	Igloo A	Igloo B	Igloo C	Igloo D	Igloo E
Arrival of main blast at ground Kistler gauges, CL of igloo	40.5	41	93.5	81	73
Arrival of main blast at headwall Kistler gauges (av.)	40	40.7	91.7	80.5	72.2
First response from linear motion transducers (av.)	81.2	96.2	...	...	...
First response from single axis accelerometers					
Front vertical position	45	46	...	...	...
Middle 45-degree position	46	47 <sup>a</sup>	...	...	...
Rear vertical position	47	49	...	...	...

<sup>a</sup> 8 ft above horizontal rather than at 45 deg.

TABLE 5. Data From Accelerometers.

Igloo	Position	Direction of measurement	Maximum acceleration, g	Maximum velocity, ft/sec	
				Inward	Outward
A	Front one-quarter on CL	Vertical	20	7.5	6.3
	Midsection on CL	Vertical	40	Not derived	
	Rear one-quarter on CL	Vertical	30	Not derived	
	Midsection	45 deg. toward donor	23	5.1	0.8
	Midsection on CL	Horizontal	40	Not derived	
B	Front one-quarter on CL	Vertical <sup>a</sup>	35	5.4	9.0
	Midsection on CL	Vertical	40	Not derived	
	Rear one-quarter on CL	Vertical	40	Not derived	
	Midsection	Toward donor	30	3.4	4.0
	Midsection on CL	Horizontal	40	Not derived	

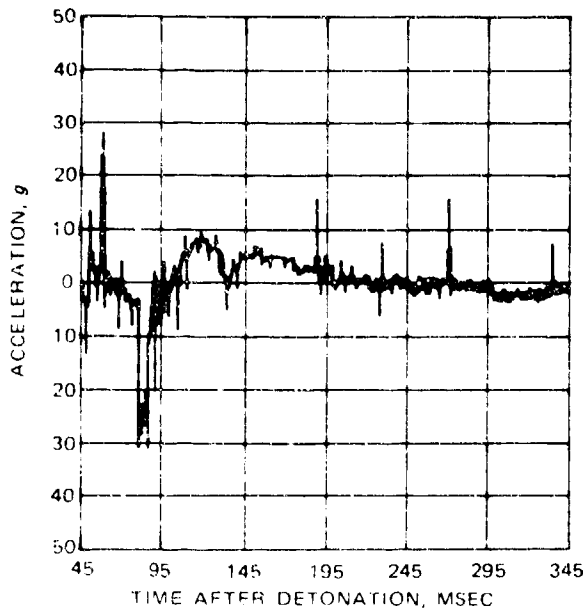

(a) Accelerometer record.

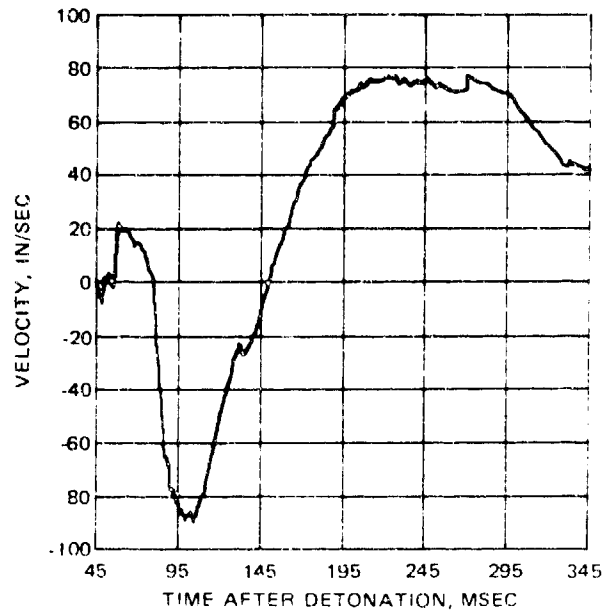

(b) Velocities derived from accelerometer record.

FIGURE 28. Accelerometer Data. These data were obtained from the accelerometer located on the vertical centerline of Igloo A and 20 feet from the door and headwalls.

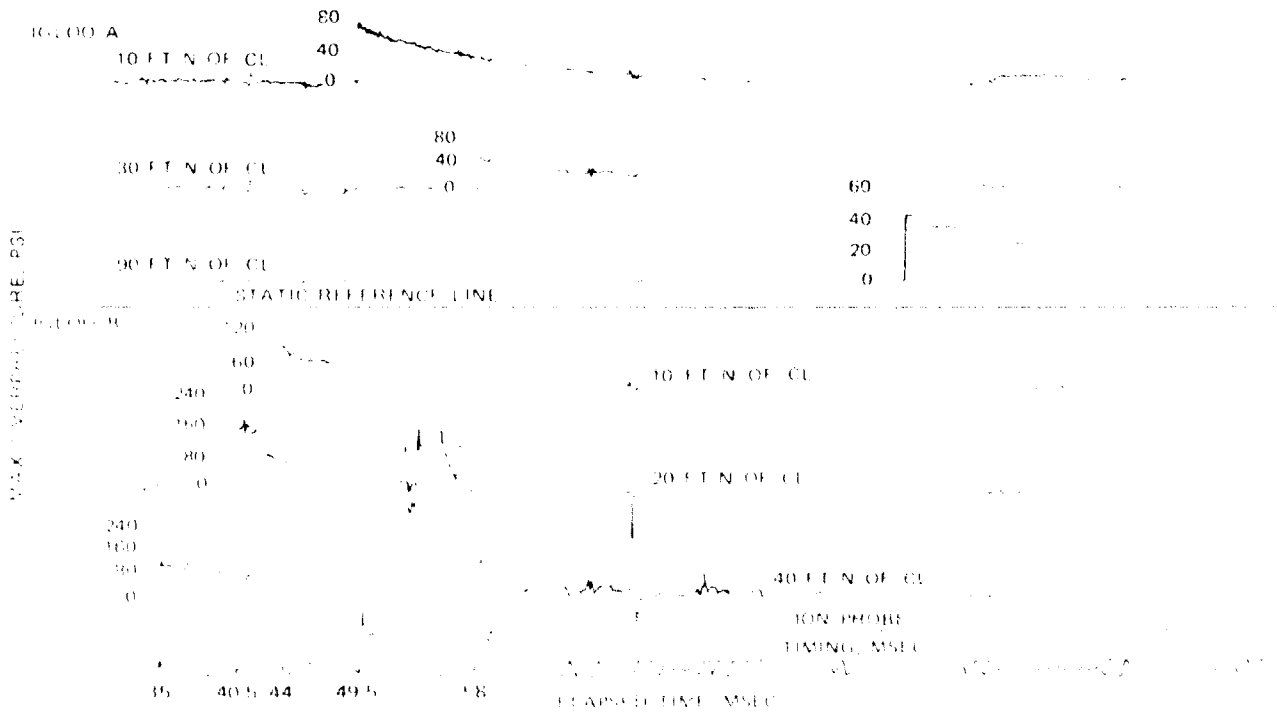

FIGURE 29. Kistler Piezoelectric Blast Gauge Data. Time of blast arrival versus peak overpressure. Gauges located on the earth fill at Igloos A and B.

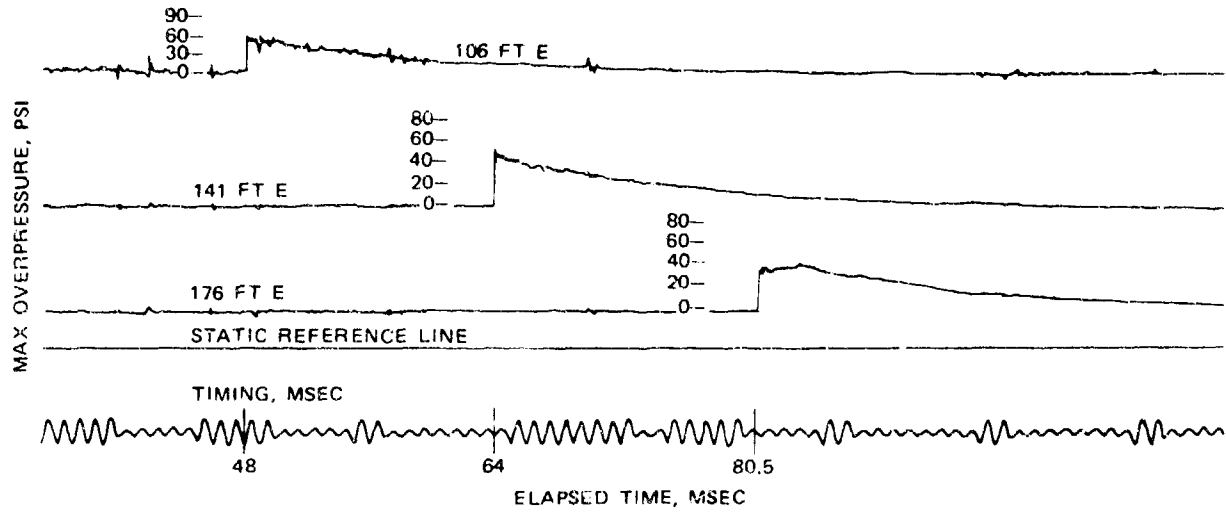

FIGURE 30. Kistler Piezoelectric Blast Gauge Data. Time of blast arrival versus peak overpressure. Gauges located to the rear of the donor igloo.

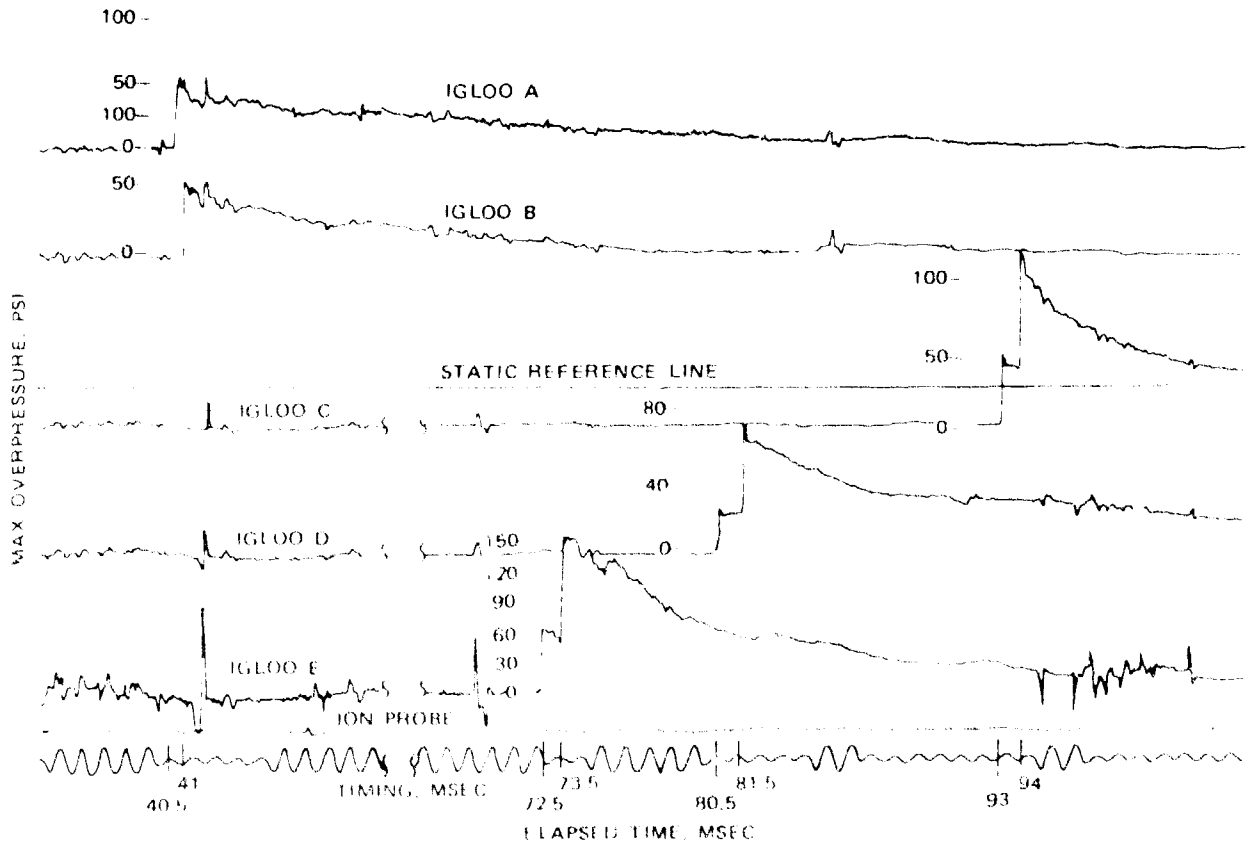

FIGURE 31. Kistler Piezoelectric Blast Gauge Data. Time of blast arrival versus peak overpressure. Gauges located at ground level in front of the igloos. Note that the time scale has been overlapped in order to show all events on the one figure.

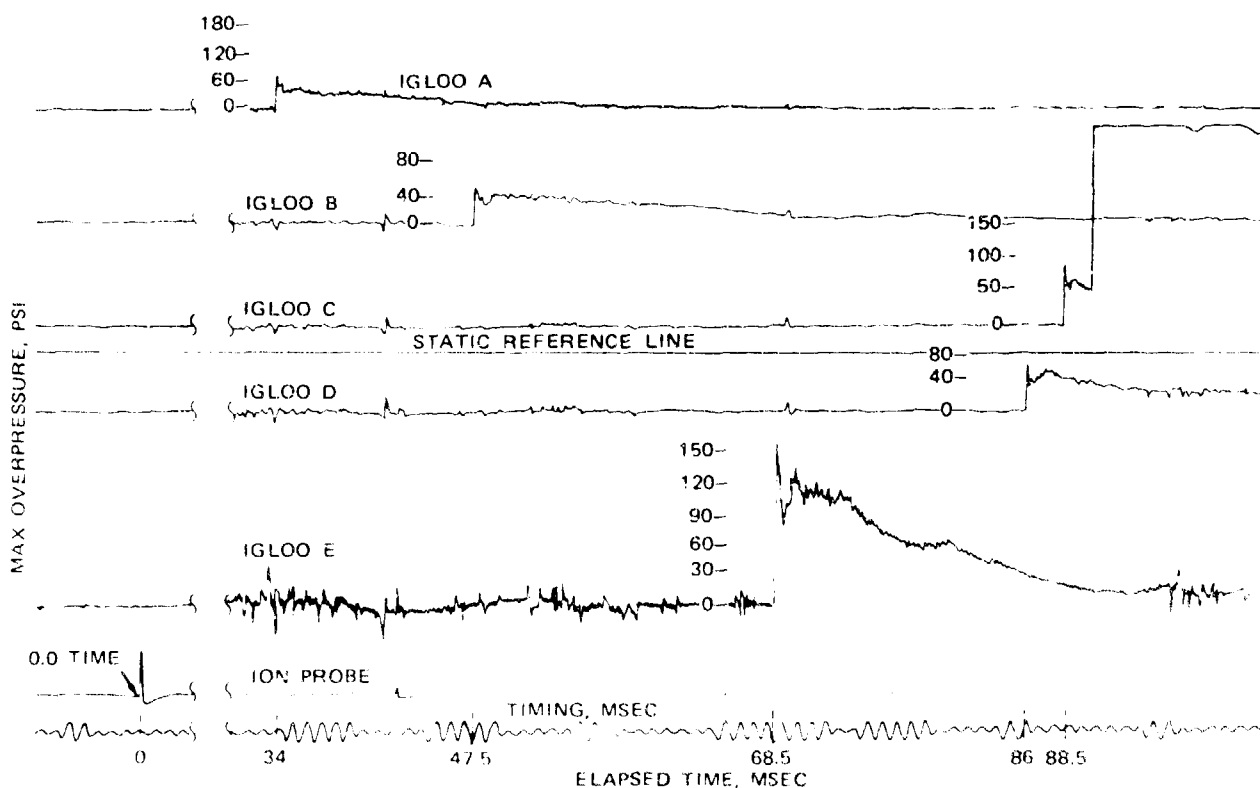

FIGURE 32. Kistler Piezoelectric Blast Gauge Data. Time of blast arrival versus peak overpressure. Gauges located in the right headwall of each igloo.

### MOTION-PICTURE PHOTOGRAPHY

The main test event was recorded photographically by ground-based 16-mm and 35-mm cameras and by 16-mm and 70-mm aerial photography. Film speeds varied from 10 frames per second for the aerial 70-mm camera to 4,000 frames per second for two 16-mm cameras providing specific views of the donor and Igloos A, B, and D. Cameras placed inside the magazines operated at 400 frames per second to record on film the responses of igloo arches and headwalls to the blast.

## BLAST GAUGE DATA

## General

The blast gauge instrumentation consisted of two basically different types of gauges: (1) BRL self-recording mechanical gauges placed at distances ranging from 660 to 3,526 feet from the donor center and (2) Kistler piezoelectric gauges, which have greater frequency-response characteristics, placed in the headwalls of the magazines, in the ground in front of the igloo headwalls, and in the ground over the arches of Igloos A and B. Tables 6 and 7 present data from BRL mechanical and Kistler piezoelectric gauges.

TABLE 6. Far-Field BRL Gauge Data.

Direction	Distance, ft	Max. overpressure, psi		Impulse, psi-msec <sup>d</sup>	Duration, msec
		Direct reading	Machine extrapolation		
East	660	5.5	6.34	72.51 <sup>b</sup>	72.51 <sup>b</sup>
East	660	5.5	...	...	...
East	1,320	2.4	2.40	187.74	202.13
East	1,320	1.8	...	...	...
Southwest	660	11.9	10.8	515.93	116.82
Southwest	660	11.6	10.4	529.68	138.88
Southwest	1,320	2.2	...	...	...
Southwest	1,320	2.6	2.88	223.68	152.02
Southwest	2,115	1.3	1.28	136.33	249.62
Southwest	2,115	1.4	1.48	172.10	278.21
Southwest	2,630	0.8	0.75	55.70	155.97
Southwest	2,630	0.8	...	...	...
Northwest	660	7.4	8.06	428.65	142.45
Northwest	660	8.1	8.3	435.30	137.38
Northwest	1,320	3.3	...	...	...
Northwest	1,320	3.6	...	...	...
Northwest	2,115	1.6	...	...	...
Northwest	2,115	1.2	1.21	112.03	204.17
Northwest	2,630	1.3	1.27	149.32	257.47
Northwest	2,630	1.2	1.15	80.96	104.68
Northwest	3,526	0.73	0.88	20.35	70.45
Northwest	3,526	0.41	...	...	...

NOTE: Leaders indicate lack of recorded data.

<sup>d</sup> Direct reading.

<sup>b</sup> Measurements are unreliable.

TABLE 7. Near-Field Kistler Gauge Data.

Gauge position	Horizontal distribution from geometric center of donor igloo, ft	Time of blast arrival, msec	Peak overpressure, psi		Impulse, psi-msec
			Incident	Reflected	
Igloo A, ground CL	121	40.5	50	...	351
Igloo B, ground CL	121	41	65	...	416.5
Igloo A, headwall north	130	46	60	...	794.6
Igloo B, headwall south	130	47.5	40	...	593.1
Igloo A, headwall south	111	34	75	...	615.6
Igloo B, headwall north	111	34	55	...	599.6
Igloo A, cover 30N <sup>a</sup>	144	58	40	...	483.7
Igloo B, cover 30S <sup>b</sup>	144	...	...	...	...
Igloo A, cover 10N <sup>a</sup>	124	49.5	78	...	621.6
Igloo B, cover 10S <sup>b</sup>	124	51	85	...	642
Igloo A, cover 10S <sup>b</sup>	104	42.5	80	...	529.4
Igloo B, cover 10N <sup>a</sup>	104	44	95	...	806.4
Igloo A, cover 20S <sup>b</sup>	94	...	...	...	...
Igloo B, cover 20N <sup>a</sup>	94	40.5	165	...	661.5
Igloo A, cover 40S <sup>b</sup>	74	33.5	110	...	...
Igloo B, cover 40N <sup>a</sup>	74	35	120	...	803.7
Igloo A, ground 90N <sup>a</sup>	204	89.5	55	...	626.5
Igloo B, ground 60S <sup>b</sup>	174	75	50	...	652
Igloo D, right headwall	281	86	...	75	512.3
Igloo C, left headwall	279	92	...	325 <sup>c</sup>	...
Igloo D, ground CL	267	80.5, 81.5	25	70	805.6
Igloo C, ground CL	270	93, 94	45	115	886.0
Igloo C, right headwall	265	88.5	...	95	...
Igloo D, left headwall	257	75	...	75	891
Igloo E, left headwall	310	76	...	150	1,257.6
Igloo E, ground CL	298	72.5, 73.5	75	180	1,101.4
Igloo E, right headwall	290	68.5	...	165	1,552.0
Donor 106E <sup>c</sup>	146	48	55	...	648
Donor 141E <sup>c</sup>	181	64	55	...	648.4
Donor 176E <sup>c</sup>	216	80.5	40	...	521.0

<sup>a</sup> Feet north of the centerline of the igloo.

<sup>b</sup> Feet south of the centerline of the igloo.

<sup>c</sup> Feet to the rear of the donor magazine, measured from the rear wall of the igloo.

## BRI Gauges

Data from BRI gauges are given in Table 6. The computer assessment of BRI records produced (1) tabulations of the overpressure and impulse versus time and (2) plots of the data. Figures 37 through 47 show the plotted data for 14 of the 21 BRI gauges. In addition, the computer plotted the first part of the overpressure curve on a semilogarithmic scale and fitted a least squares line to the curve, permitting an extrapolation to zero time for determining the most likely real initial overpressure. Figure 48 shows such a plot. This procedure was devised to reduce the effect of slow response by the BRI gauges at the leading edge of the shock wave.

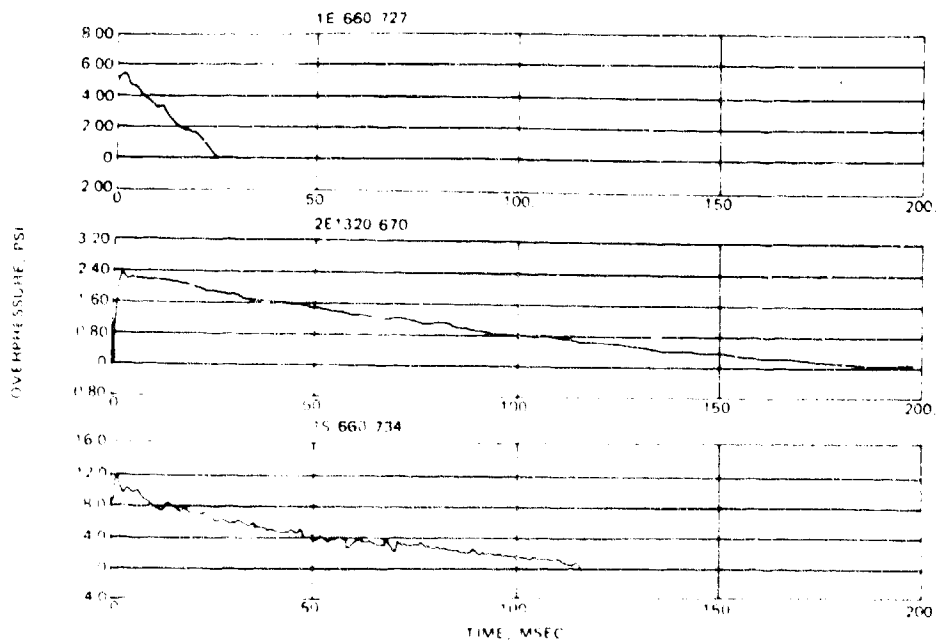

FIGURE 33. Data Plots for BRT Gauges on the East Leg (see Figure 2) at 660 and 1,320 Feet and the Southwest Leg at 660 Feet. The numbers above the plots refer to the distance from the donor. Gauges that registered only the maximum overpressure have been omitted from this series.

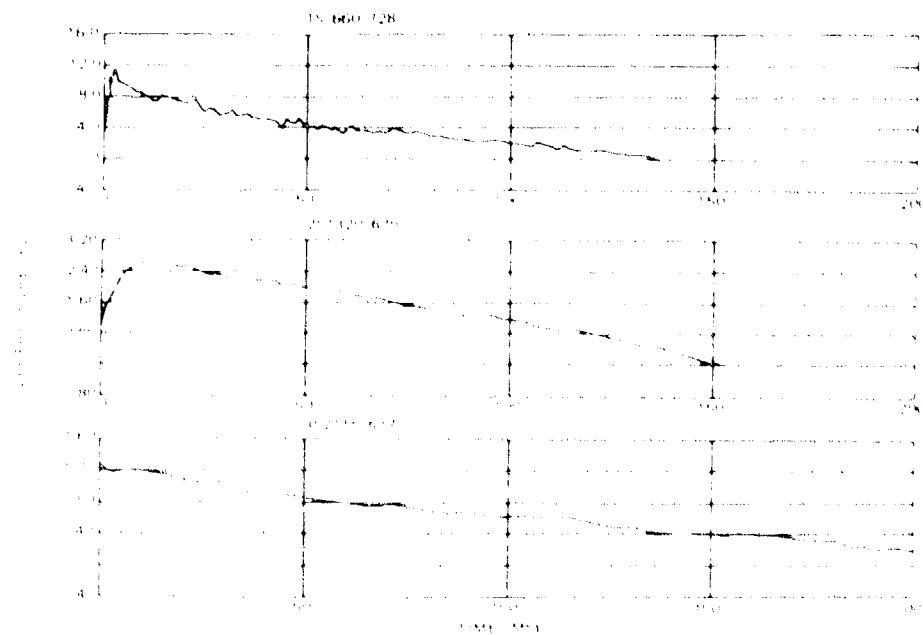

FIGURE 34. Data Plots for BRT Gauges on the Southwest Leg at 660, 1,320, and 2,115 Feet.

NWC TF 5771

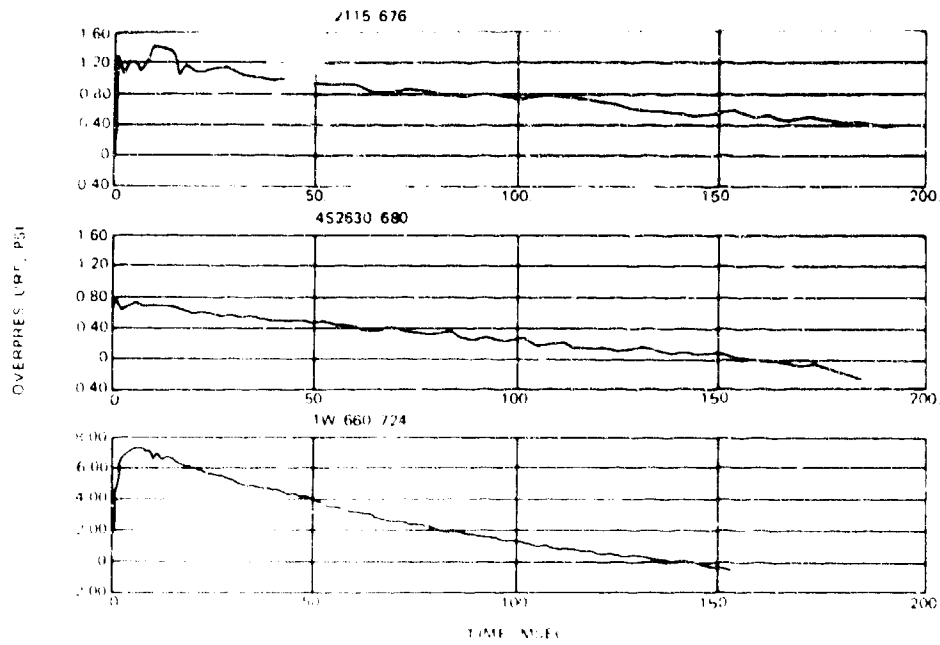

FIGURE 35. Data Plots for BRI Gauges on the Southwest Leg at 2,115 and 2,630 Feet, and the Northwest Leg at 660 Feet.

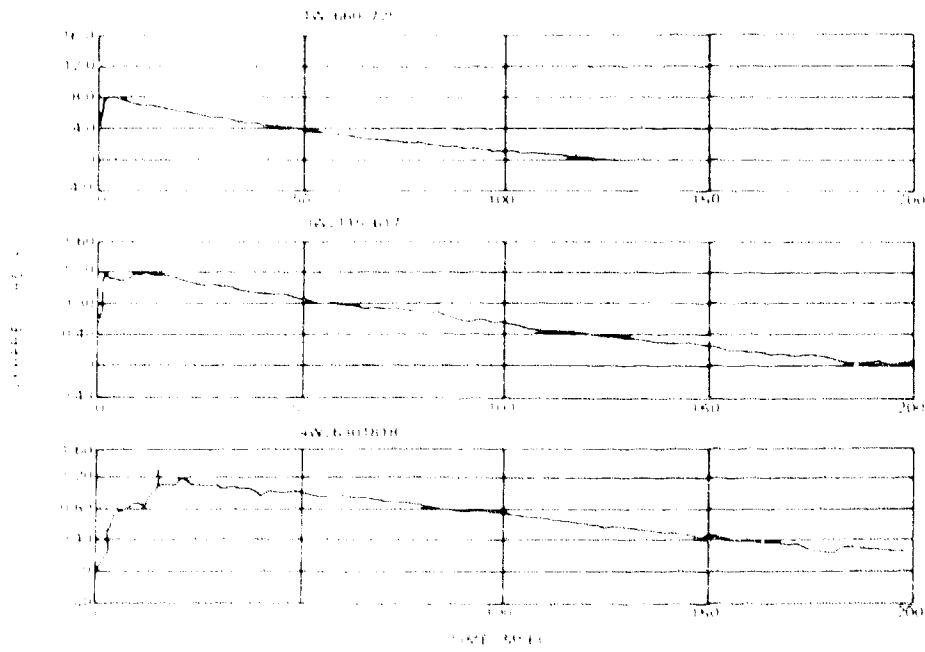

FIGURE 36. Data Plots for BRI Gauges on the Northwest Leg at 660, 2,115, and 2,630 Feet.

NWC TP 5771

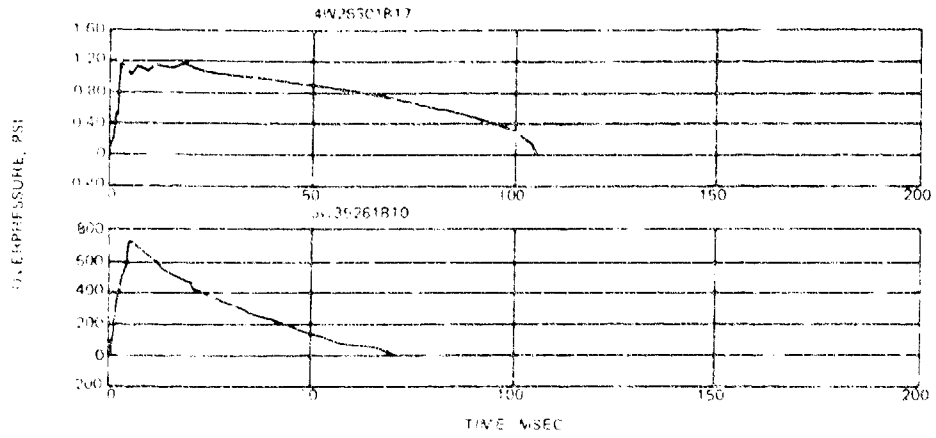

FIGURE 37. Data Plots for GRI Gauges on the Northwest Leg at 2,630 and 3,526 Feet.

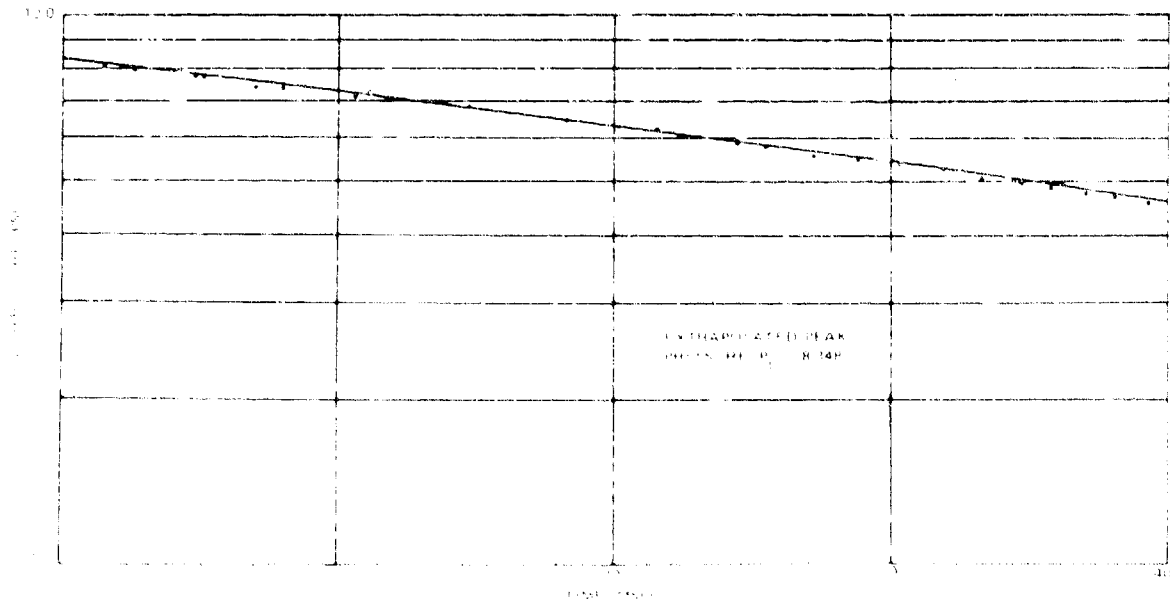

FIGURE 38. Computer Plot of First Part of Overpressure Curve From BRI Gauge 728, Located 650 Feet From the Door on the Northwest Leg.

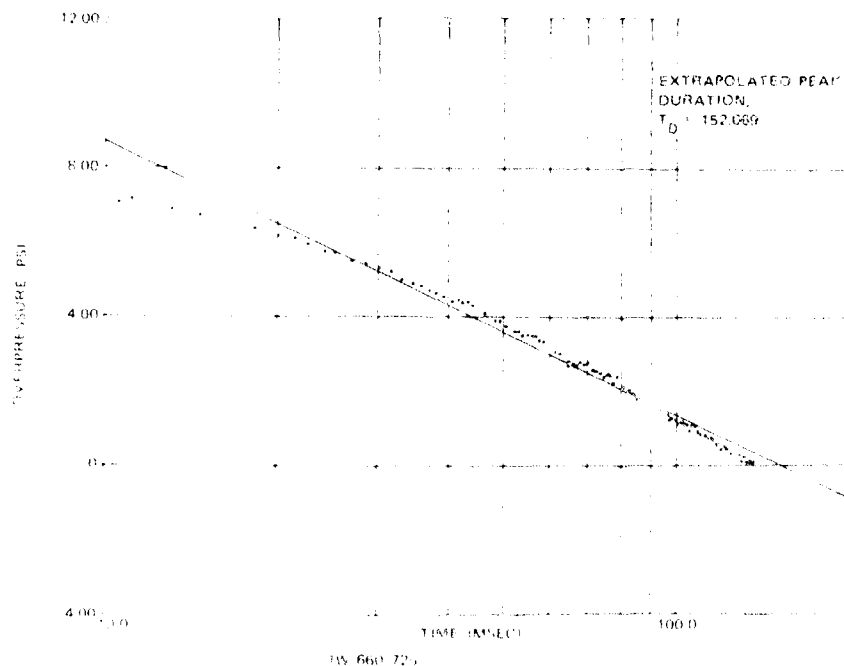

FIGURE 39. Computer Plot of Trailing Edge of Overpressure Curve From BRL Gauge 725.

Similarly, the computer plotted the trailing edge of the positive phase of the overpressure curve on a semilogarithmic scale and fitted a straight line to it, permitting extrapolation to the most likely positive-phase duration (Figure 39). The program also included the computation of impulse based on these extrapolations.

### Piezoelectric Gauges

Data from the Kistler piezoelectric gauges are presented in Table 7.

### STATIC MEASUREMENTS OF IGLOO ARCHES AND HEADWALLS

The permanent deformation of the five headwalls (Tables 8 and 9) and of the steel arches in igloos A and B (Table 10) was determined by "before" and "after" measurements at selected positions. Before the test survey monuments were set outside the blast area to define a vertical plane approximately 3 feet in front of each receptor igloo headwall; distances were measured from these planes to selected points (Figures 40 and 41) on the headwalls. After the test, these distances were again measured to determine the final deformation of the headwalls. The isopleths in Figures 42 through 46 do not represent the maximum movement experienced by the headwalls; rather, they show the permanent deformation of the headwalls.

TABLE 8. Igloo Headwall Permanent Displacement in Feet.

A negative value indicates headwall displacement *toward* the donor; a positive value indicates displacement *away from* the donor.

Station	Igloo A	Igloo C	Igloo D	Igloo E	Station	Igloo A	Igloo C	Igloo D	Igloo E
1	-0.57	0.00	-0.26	-0.18	19	-0.25	0.21	-0.06	0.73
2	-.60	.01	-.25	-.12	20	-.29	.40	-.00	0.90
3	-.69	.02	-.23	.01	21	-.32	.26	-.02	0.73
4	-.63	.04	-.20	.01	22	-.41	.17	-.09	0.23
5	-.69	.09	-.22	-.03	23	-.51	.18	-.16	-0.21
6	-.77	.10	-.20	-.11	24	-.19	.10	-.15	0.03
7	.82	.14	-.22	-.25	25	-.14	.19	-.10	0.55
8	-.87	.14	-.24	-.54	26	-.11	.29	-.06	0.99
9	-.85	.13	-.26	-.58	27	-.18	.35	-.03	1.17
10	-.46	.05	-.22	-.03	28	-.20	.24	-.07	0.49
11	.42	.13	-.18	.14	29	-.23	.17	-.12	-0.08
12	-.42	.19	-.14	.26	30	-.01	.09	-.11	-0.01
13	-.48	.19	-.13	.27	31	-.02	.11	-.11	0.01
14	.53	.19	-.13	.23	32	.03	.17	-.11	0.13
15	-.62	.15	-.15	-.02	33	.04	.16	-.09	1.47
16	-.69	.13	-.22	-.42	34	.05	.18	-.10	0.34
17	-.33	.09	-.19	-.03	35	0.02	0.17	-0.09	-0.15
18	-0.31	0.17	0.13	0.33					

TABLE 9. Igloo B Permanent Headwall Displacement in Feet.

A negative value indicates headwall displacement *toward* the donor; a positive value indicates displacement *away from* the donor.

Station	Movement	Station	Movement	Station	Movement	Station	Movement
1	0.67	21	0.37	41	0.19	61	0.22
2	.56	22	.45	42	.15	62	.26
3	-.47	23	.55	43	-.22	63	-.29
4	.40	24	.64	44	-.27	64	-.30
5	.30	25	.67	45	-.31	65	.32
6	.30	26	.53	46	.32	66	-.34
7	.15	27	.44	47	.60	67	.42
8	.15	28	.37	48	-.52	68	.47
9	.04	29	.31	49	.45	69	.51
10	.05	30	.31	50	.57	70	.41
11	.01	31	.18	51	-.52	71	.33
12	.03	32	.17	52	.29	72	.37
13	.00	33	.12	53	.27	73	-.29
14	.05	34	.11	54	.25	74	.28
15	.08	35	.08	55	.21	75	.26
16	-.11	36	.04	56	.13	76	.23
17	.15	37	.06	57	.16	77	.22
18	.15	38	.10	58	.16	78	.21
19	.11	39	.13	59	.20	79	.18
20	0.31	40	0.15	60	.20	80	0.16

TABLE 10. Steel Arch Movement, Feet.

Positive values indicate movement *toward* center of arch; negative values, *away from* arch center.

Igloo	Position	Forward one-quarter position	Midsection	Rear one-quarter position
Movement Relative to Centerline of Igloo Floor				
B	1	0.48	0.66	0.45
	2	0.11	0.22	0.17
	3 vert CL	-0.19	-0.38	-0.33
	4	-0.03	-0.01	-0.06
	5	0.16	0.20	0.13
A	1	0.06	0.11	0.11
	2	0.08	0.13	0.22
	3 vert CL	0.36	0.47	0.60
	4	0.91	1.07	1.11
	5	1.08	1.10	0.97
Absolute Movement				
B	1	0.32	0.49	0.33
	2	-0.16	-0.06	-0.04
	3 vert CL	-0.51	-0.72	-0.57
	4	-0.30	-0.29	-0.27
	5	0.00	0.03	0.01
A	1	0.00	0.04	0.04
	2	-0.07	0.01	0.10
	3 vert CL	0.24	0.33	0.46
	4	0.81	0.95	0.99
	5	1.02	1.03	0.90

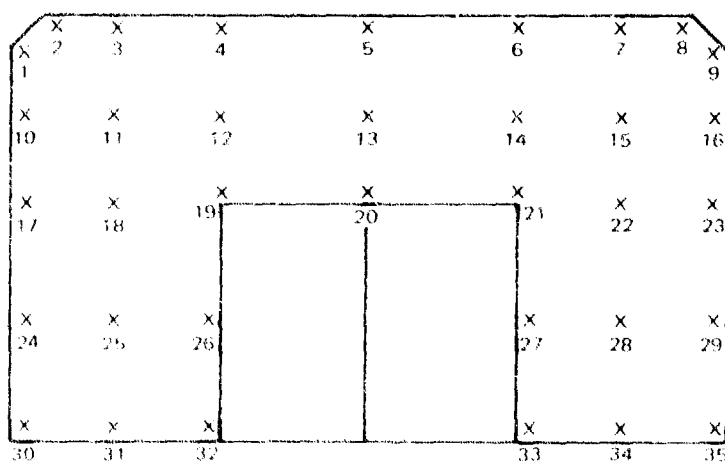

FIGURE 40. Position Key for Headwall Deformation Measurements, Igloos A, C, D, and E.

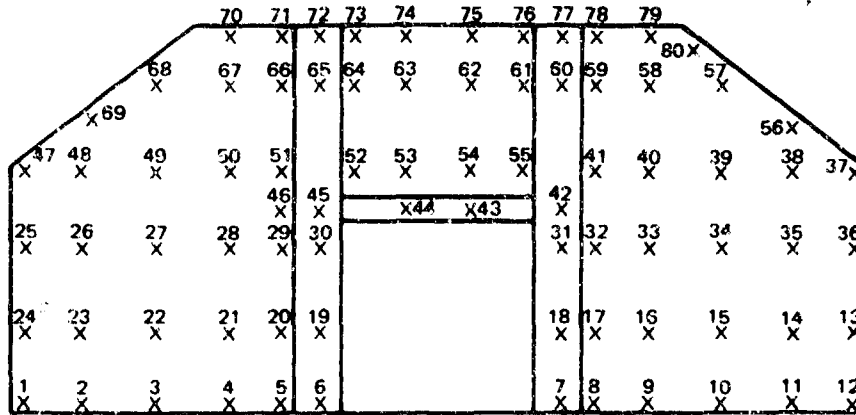

FIGURE 41. Position Key for Headwall Deformation Measurements, Igloo B.

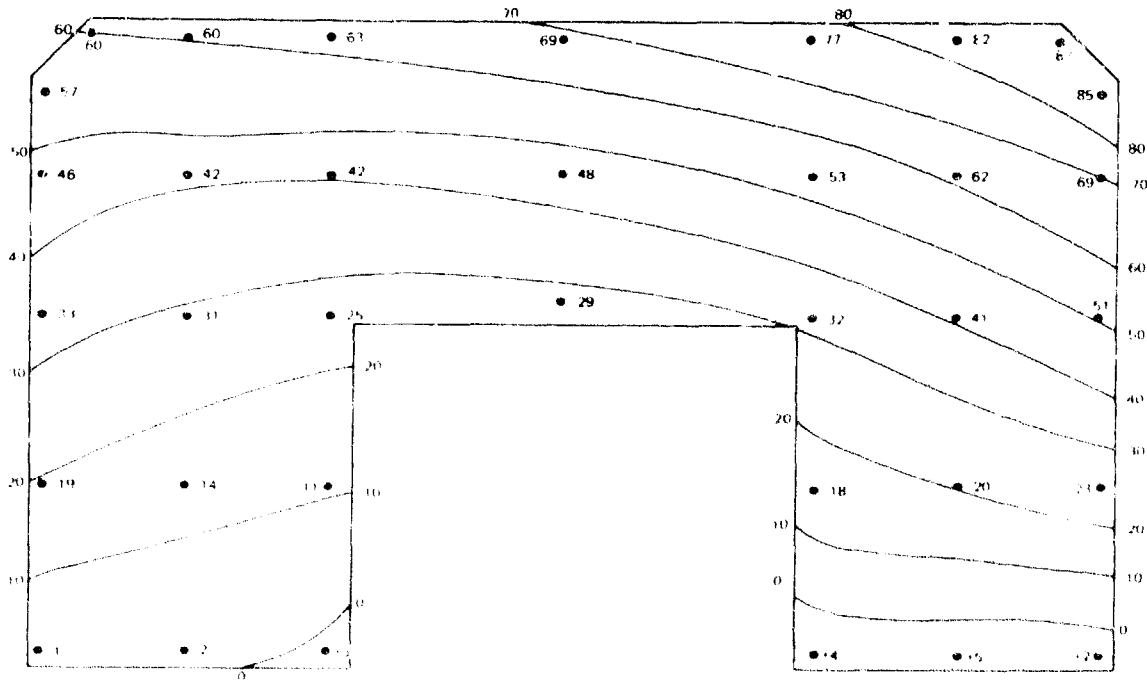

FIGURE 42. Movement of the Headwall of Igloo A. A minus value shows movement outward, toward the donor magazine; a plus value shows movement into the igloo and away from the donor. Units shown are hundredths of feet.

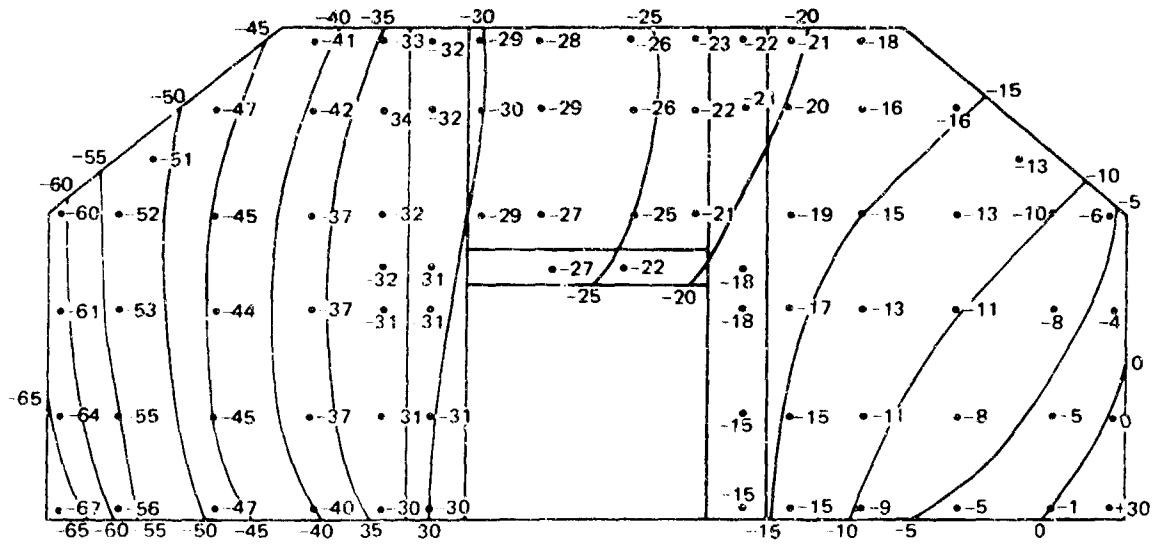

FIGURE 43. Movement of the Headwall of Igloo B. A minus value shows movements toward the donor; the single plus value indicates a movement away from the donor (into the igloo). One point showed no movement. Units shown are hundredths of feet.

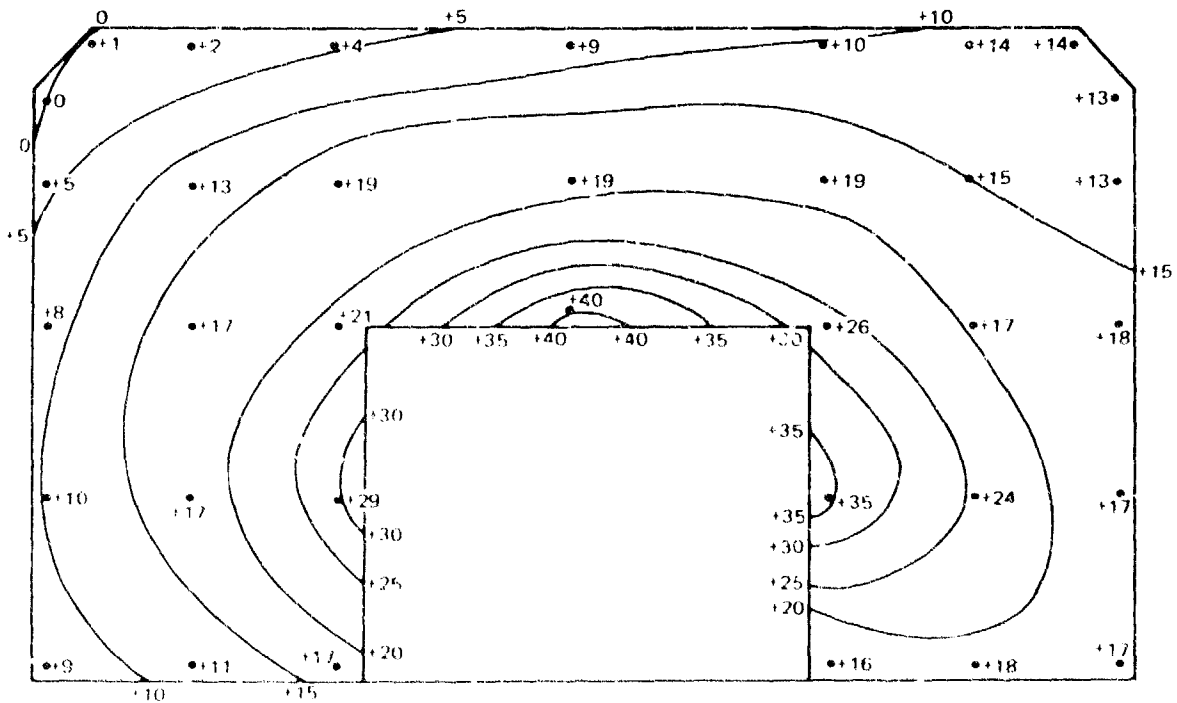

FIGURE 44. Movement of the Headwall of Igloo C. Positive values show movement away from the donor magazine. One point (upper left) showed no movement. Units shown are hundredths of feet.

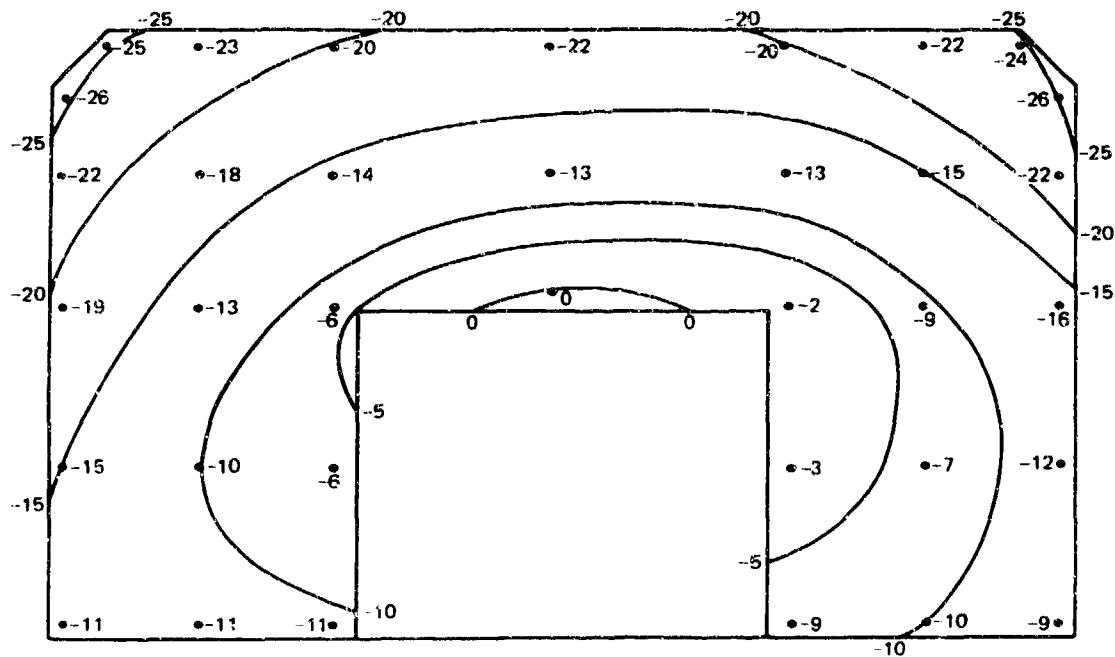

FIGURE 45. Headwall Movement, Igloo D. Minus values indicate movement outward, toward the donor; one point (above door) showed no movement. Units shown are hundredths of feet.

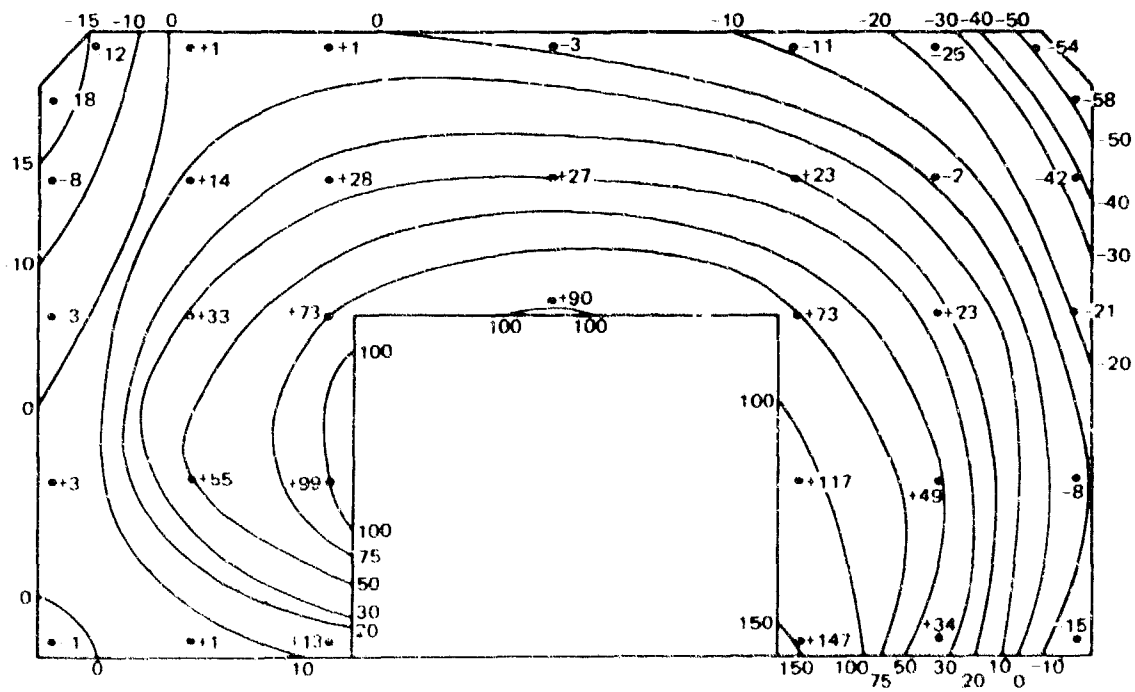

FIGURE 46. Headwall Movement of Acceptor Igloo E. Minus values show movement toward the donor, plus values, away from the donor. Units shown are hundredths of feet.

Arch deformations were measured at a minimum of five positions each (Figure 47) at the forward one-quarter (20 feet in from the headwall), midsection or 40 feet in, and 60 feet in at the rear one-quarter section of Igloos A and B. Table 10 shows arch movement at these preselected points. Note that the movement is shown in absolute terms as well as relative to floor movement. Arch movements at points of maximum deformation are illustrated in Figure 48. Since these positions were not measured before the blast, the measurements are less reliable than those shown in Table 10.

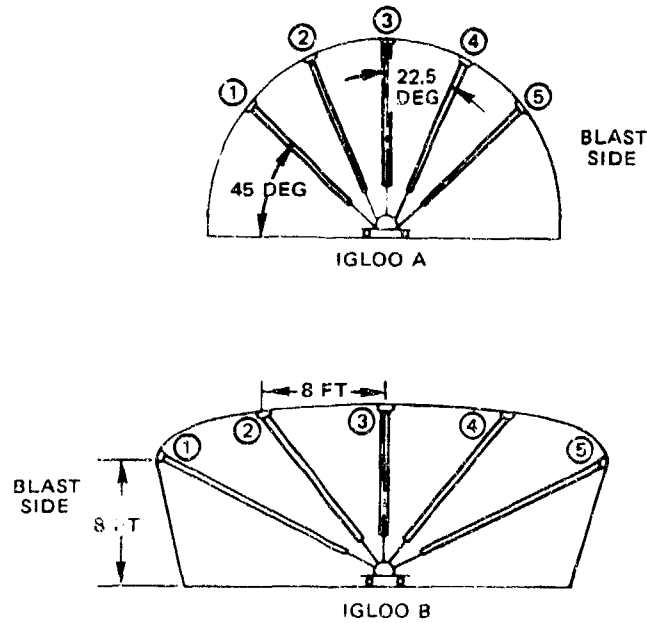

FIGURE 47. Position Key for Measurement of Arch Deformation.

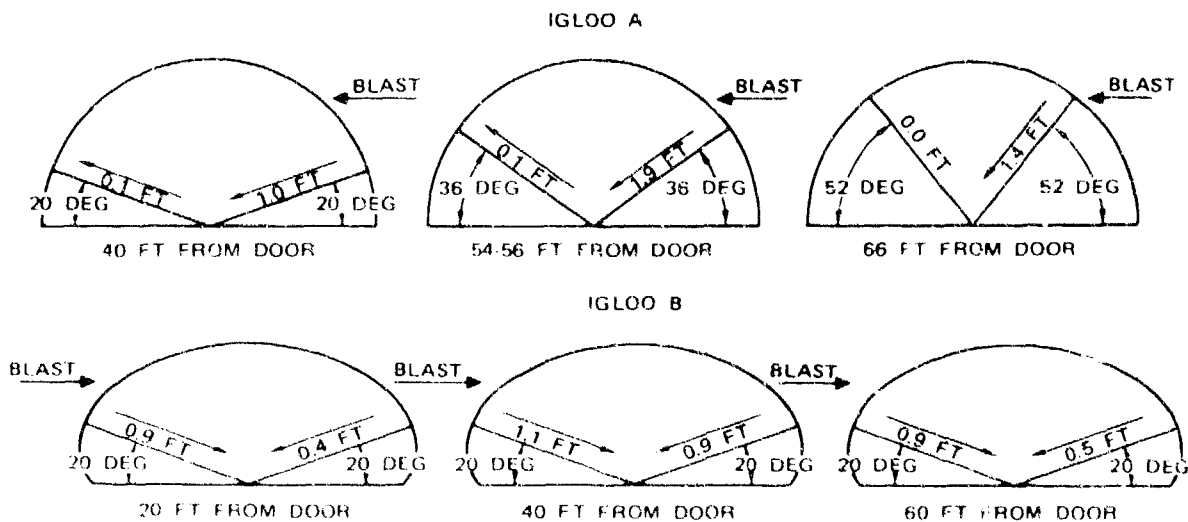

FIGURE 48. Maximum Static Arch Movements at Blast Side of Arch. Movements at corresponding positions on leeward side are also shown.

## CONCLUSIONS

The primary test objective, the qualification of the oval steel arch igloo at the  $1.25 \times W^{1/3}$  minimum side-to-side spacing, was fulfilled. Igloo B, the oval steel arch igloo, withstood the donor explosion effects very well. It is considered that all components of this structure would have provided ample protection to explosive contents in the orientation tested.

ESKIMO IV, the next in the test series, will test the resistance of the ESKIMO III Igloo B headwall and door combination to face-on blast loading that duplicates that from the detonation of the contents of a close (at the minimum front-to-rear distance now permitted by standards) magazine that is filled with mass-detonating ammunition.

The light-gauge, deeply corrugated arch tested in Igloo A also withstood the blast at the  $1.25 \times W^{1/3}$  side-to-side spacing. However, the degree of damage was considerably more extensive and arch distortion was greater than in Igloo B. It is considered that the arch structure would have provided adequate protection against explosion communication for common explosive stores. The most hazardous response in this igloo was the inward motion of the door; however, this, too, was at low velocity and of marginal significance. This door action was unrelated to the response of the arch.

The single-leaf sliding door installed in the existing headwall of Igloo C at  $2.75 \times W^{1/3}$  withstood the blast with little apparent damage or deformation. The damage experienced by the headwall, although readily visible, would not have provided a significant explosion hazard to the magazine contents. The single-leaf sliding door appears to be an acceptable improvement to existing igloos.

The two-leaf hinged door on Igloo D responded to the blast by moving inward at velocities believed to have been sufficiently low to prevent explosion damage to magazine contents; however, the door performance is considered marginal. The headwall of Igloo D, while maintaining some damage, did not appear to represent a hazard. The test results as a whole do not appear to justify a relaxation in existing standards for the special case represented by the orientation of Igloo D.

The response of the headwall and door in Igloo E was clearly unsatisfactory and provided no reason for reducing the present  $6 \times W^{1/3}$  separation distance now specified for this orientation and condition.

Results and general conclusions from the study of the effects of blast on the window test vehicles and cubicles are described in Appendix B. In general, the test supported the U.S. inhabited-building distance standards and the U.S. public highway separation distances.

## Appendix A

### CONSTRUCTION INFORMATION

Igloos B, C, D, and E remained from earlier tests. Igloo A and the donor igloo were constructed for this test. New headwalls were built for Igloos B, D, and E at about the same time as for the donor and for Igloo A. Table A-1 summarizes the arch, headwall, and door designs for each igloo.

Table A-2 contains the sieve analysis of the fill material used around Igloo A and the donor. The depths given are beneath the normal ground level at the location where the fill was collected. The earth appeared to change consistency at a depth of about 5 feet, but analysis showed it to consist of smaller pieces of the same nonplastic materials present at higher levels, silty sand and sand-silt mixtures.

Table A-3 reports the tested densities of the fill material around Igloo A and the donor, and Table A-4 summarizes the results of tests for concrete compressive strength made on sample cylinders poured from the same batches of concrete that were used to construct the test igloos.

#### Backfill Procedures Used for Igloo A and the Donor Igloo

Fill was placed in 1-foot-deep layers, then compacted with a sheeps foot roller (which was kept at least 4 feet from the arches) and a steel drum roller until it reached a height of 10 feet above the finished floor of the igloos. At this point in the fill operation, the corrugated steel arch began to deform and the roof to rise.

The remainder of the fill was then placed with equipment having a gross weight of 6 tons and was compacted with a steel drum roller having a gross weight of 2 tons. The 14-gauge deeply corrugated arch with side fill in place will support these weights with no damage.

The maximum deformation in height of Igloo A was 1 inch. After the filling operation was completed, this stabilized to 3/4 inch. The maximum deformation in height of the donor igloo was 3/4 inch. After the filling operation was complete, this stabilized to 1/2 inch.

TABLE A-1. Igloo Construction.

Igloo	Length, ft	Steel arch, floor, rear wall, and earth cover	Door and door drawing	Headwall and headwall drawing
A and d nor	80	All new construction, deep corrugated 14-gauge steel arch.	Hinged, two-leaf—same as ESKIMO I, OCE <sup>a</sup> Std. Dwg. 33-15-64.	Same as ESKIMO I, OCE Std. Dwg. 33-15-64.
B	80	Remaining from ESKIMO II. Steel arch is 1 gauge and of noncircular cross section.	Single-leaf, sliding, horizontally spanning door.	Modified Stradley type.
C	59	Remaining from 1963 Igloo Separation Tests. 1-gauge circular arch.	Single-leaf, sliding, horizontally spanning door.	Remaining from 1963. Similar to ESKIMO I with slight modification to accept the sliding door.
D	10	Remaining from ESKIMO II. 1-gauge circular arch.	Hinged, two-leaf—same as ESKIMO I, OCE Std. Dwg. 33-15-64.	Same as ESKIMO I, OCE Std. Dwg. 33-15-64.
E	20	Remaining from ESKIMO I and II. 1-gauge circular arch.	Hinged, two-leaf—same as ESKIMO I, OCE Std. Dwg. 33-15-64.	Same as ESKIMO I, OCE Std. Dwg. 33-15-64.

<sup>a</sup> OCE, Office of the Chief of Engineers.

TABLE A-2. Sieve Analysis of Sand-Silt Fill Material.

Sieve size	Cumulative % passing
Sample Depth, 1 Ft	
No. 200	12.3
No. 100	22.2
No. 50	37.1
No. 30	47.9
No. 16	55.2
No. 8	63.6
No. 4	74.3
3/8 in.	88.3
1/2 in.	95.3
3/4 in.	95.3
Sample Depth, 5 Ft	
No. 200	14.1
No. 100	24.8
No. 50	40.1
No. 30	50.9
No. 16	58.7
No. 8	68.6
No. 4	80.3
3/8 in.	94.6
1/2 in.	97.2
3/4 in.	100

TABLE A-3. Density Report, Fill Material.

Location	Depth above finished floor, ft	Date	Field moisture, %	In-place density,	Lab moisture, %	Lab density,	Percent compaction
Igloo A							
North side	4	4-10-74	8.5	121.5	10.3	123.3	98.6
South side	4	4-10-74	7.6	120.2	10.3	123.3	97.5
North side	5	4-11-74	8.5	124.0	11.2	124.0	100
South side	6	4-11-74	11.2	124.0	11.2	124.0	100
North side	7	4-11-74	10.3	121.6	11.2	124.0	98.1
South side	7	4-11-74	11.2	120.8	11.2	124.0	97.5
South side	10	4-12-74	9.7	124.0	11.2	124.0	100
North side	10	4-12-74	8.7	119.1	11.2	124.0	96.1
South side	11	4-15-74	9.0	124.0	11.2	124.0	100
North side	11	4-15-74	8.6	123.0	11.2	124.0	99.2
Back	11	4-15-74	9.0	121.2	11.2	124.0	97.7
South side	12	4-16-74	8.5	123.7	11.2	124.0	99.8
North side	12	4-16-74	8.9	124.0	11.2	124.0	100
North side	13	4-17-74	9.4	124.0	11.2	124.0	100
South side	13	4-17-74	10.6	123.4	11.2	124.0	99.6
North side	15	4-17-74	9.2	114.0	11.2	124.0	91.9
South side	15	4-17-74	9.2	114.4	11.2	124.0	92.3
North side	16	4-19-74	8.5	123.3	11.2	124.0	99.3
CL front	17	4-19-74	11.1	120.9	11.2	124.0	97.6
CL middle	17	4-19-74	10.0	122.9	11.2	124.0	99.1
CL back	17	4-19-74	12.6	120.9	11.2	124.0	97.5
Denar Igloo							
North side	5	4-2-74	9.3	124.0	10.3	123.3	100.8
South side	6	4-2-74	7.8	117.2	10.3	123.3	95.1
North side	8	4-3-74	9.0	117.9	10.3	123.3	95.6
South side	8	4-3-74	12	114.6	10.3	123.3	92.9
North side	10	4-3-74	9.7	123.3	10.3	123.3	100.0
South side	10	4-4-74	11.0	123.0	10.3	123.3	99.7
Back wall	11	4-4-74	9.4	121.1	10.3	123.3	98.2
North side	12	4-5-74	8.5	119.1	10.3	123.3	96.6
South side	12	4-5-74	10.0	117.5	10.3	123.3	95.3
North side	13	4-6-74	10.9	119.1	10.3	123.3	96.6
South side	13	4-6-74	10.2	122.9	10.3	123.3	99.7
South side	15	4-6-74	9.5	122.2	10.3	123.3	99.1
North side	15	4-7-74	8.9	125.6	10.3	123.3	101.8
South side, 2 ft south of CL, middle	16	4-7-74	8.2	119.8	10.3	123.3	97.2
CL 5 ft from front	Top of fill	4-8-74	8.1	118.6	10.3	123.3	96.3
CL middle	Top of fill	4-8-74	8.7	120.7	10.3	123.3	97.9
CL 5 ft from back	Top of fill	4-8-74	2.5	113.6	10.3	123.3	92.1

TABLE A-4. Concrete Compressive Strength, ESKIMO III Test Structures.

Date cast	Igloo	Location in structure	Class of concrete	Age at test, days	Compressive strength, psi
24 Jan 1974	Donor	North and south footing	E-1 3,000 psi	7	2,174
				7	2,635
				14	2,609
				14	2,748
				28	3,553
30 Jan 1974	E	Front wall	E-1 3,000 psi	7	2,511
				14	2,937
				28	3,490
				28	3,730
				28	3,730
7 Feb 1974	Donor	Floor	E-1 3,000 psi	7	2,156
				14	3,687
				21	3,782
				28	4,014
				28	4,033
12 Feb 1974	A	North and south footing	E-1 3,000 psi <sup>d</sup>	7	2,327
				14	2,669
				28	3,045
				28	3,062
				28	3,080
15 Feb 1974	B	Front wall	G-1 4,000 psi	7	2,773
				14	3,547
				28	4,313
				28	4,493
				28	4,493
26 Feb 1974	A	East and west footing	E-1 3,000 psi	7	2,142
				14	2,795
				14	3,110
				28	3,814
				28	3,849
18 Mar 1974	Donor	Back wall	E-1 3,000 psi <sup>d</sup>	7	2,669
				17	3,490
				28	3,571
				28	3,697
19 Mar 1974	Donor	Front wall	E-1 3,000 psi <sup>d</sup>	7	2,921
				15	2,540
				28	3,051
				28	3,779
22 Mar 1974	A	Back wall	E-1 3,000 psi	7	2,281
				17	3,227
				28	3,547
				28	3,896
28 Mar 1974	A	Front wall	E-1 3,000 psi	11	2,921
				18	3,016
				28	3,374
				28	3,741
		D <sup>b</sup>	Front wall	E-1 3,000 psi	50
				50	3,148
				50	3,400
				50	3,468

<sup>d</sup> Calcium chloride was added to the concrete.

<sup>b</sup> Cylinders were not made. 2 1/2 in. cores were taken, and compression tests were taken on each core to determine the compressive strength.

**Appendix B**

**AIRBLAST EFFECTS ON WINDOWS IN BUILDINGS AND  
AUTOMOBILES ON THE ESKIMO III EVENT**

Appendix B, a Lovelace Foundation report that complements the ESKIMO III report, is presented here with minor editorial changes. Tables and figures enclosed herein are facsimile reproductions of those in the Lovelace report.

**Preceding page blank**

## AIRBLAST EFFECTS ON WINDOWS IN BUILDINGS AND AUTOMOBILES ON THE ESKIMO III EVENT

E. R. Fletcher, D. R. Richmond, and D. W. Richmond  
Lovelace Foundation for Medical Education and Research  
Albuquerque, New Mexico 87103

### INTRODUCTION

#### Objectives

The objectives of this project were:

1. to determine the velocities, masses, and spatial densities of the fragments from three types of standard plate-glass windows mounted in closed, cubical structures at three ranges from ground zero;
2. to determine the same quantities for window fragments inside three automobiles, one oriented side-on and two oriented head-on to ground zero;
3. to document the window damage in ten automobiles located at three ground ranges;
4. to study the response of a clothed anthropomorphic dummy (a) standing behind one of the plate-glass windows and (b) sitting in an automobile; and
5. to estimate the hazards to occupants of buildings and automobiles exposed to similar levels of airblast.

#### Background

In order to assess the flying-glass hazard to occupants of buildings, houses, and automobiles in the vicinity of an explosion, it is necessary to have information concerning the characteristics of fragments from windows broken by airblast. Reference 1 describes several experiments conducted over the past 20 years, which provide data for a limited number of window types and conditions of exposure. More recently, a study was undertaken during the ESKIMO II test in which 13.9 tons of explosive material was detonated at the Naval Weapons Center, China Lake, California in May of 1973 (Reference 2). Plate-glass windows of three designs were placed in cubical structures at overpressure levels between 0.7 and 0.8 psi, and conventional automobiles were positioned from 0.4 to 1.2 psi. The ESKIMO III test provided an opportunity to evaluate the effects of yield by exposing similar plate-glass windows and automobiles to approximately the same overpressures in the vicinity of a much larger explosion (175 tons).

## PROCEDURE

### Modules

Ten 9-foot cubical boxes called modules (used previously on the ESKIMO II test) were positioned along the northwest radial by Chira Lake personnel. Three modules abutted one another at the 5,920-foot range, three at 3,950 feet, and four at 3,525 feet (see Figure 1). The only openings into each module were a hole where a window was mounted and an access door which was closed during the blast. All of the windows faced ground zero.

### Windows

The three types of windows used on the ESKIMO II and III tests are shown at the bottom of Table I. Types W1 and W2, designated as projected and horizontal-sliding, respectively, are commercial-type windows used extensively in government buildings and comply with, but do not exceed, the Architectural Aluminum Manufacturers Association (AAMA) specifications. The Type W3 window-walls were mounted in a neoprene structural gasket system used in Federal office buildings but no AAMA specifications are available. Three Type W1, four Type W2, and three Type W3 windows were mounted one each in the ten modules. One window of each type was tested at three ranges. The additional Type W2 window was located at the 3,525-foot range. The panes were spray painted different colors to aid in identifying the sources of the trapped fragments (see Table I).

### Automobiles

Eight automobiles were exposed side-on to the blast, five at a range of 2,115 feet, two at 2,630 feet, and one at 3,950 feet (see Figure 1). Two additional automobiles were exposed head-on at a range of 2,115 feet.

### Styrofoam

A Styrofoam witness plate was mounted on the inside back wall of nine of the modules in an attempt to trap glass fragments if the window was broken by the blast wave. The witness plates were fabricated at the Lovelace Foundation using low-density Styrofoam (Type II, described in Reference 2) glued to 1/2-inch plywood. Each witness plate included two pieces of Styrofoam each 90 inches long, 32 1/2 inches wide, and 6 inches thick. In each module the distance from the window to the surface of the Styrofoam was approximately 84 inches. Similar, but smaller witness plates, each containing one piece of Styrofoam 32 inches high, 43 inches wide, and 6 inches thick, were mounted in the automobiles. One witness plate was installed in automobile A1, one in A2, and two in A3 such that Styrofoam was located approximately 32 inches behind each of the windows which faced ground zero in these three vehicles. Calibration techniques, described in Reference 3, were used to develop a formula for determining the velocity of a fragment from its mass and the volume of the impression it made in the Styrofoam.

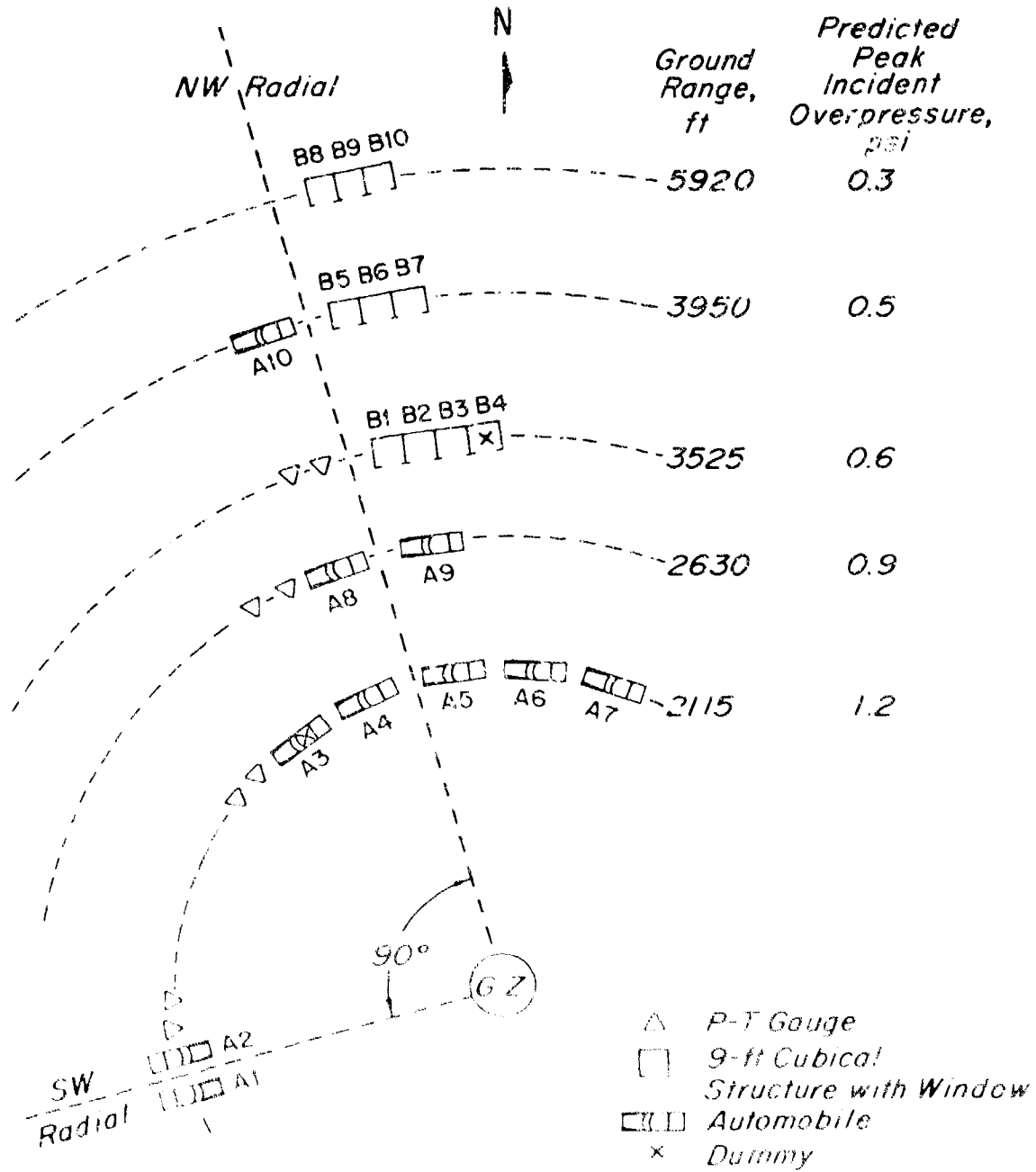

FIGURE 1. Car Field Layout for the Eskimo III Test

TABLE I  
DESCRIPTION OF THE WINDOWS IN THE MODULES

Window Type	Parameters for Individual Panes					
	Number	Color*	Width, in.	Height, in.	Type of Glass	Frame Type
W1	P1	Copper	45	45	Plate	Fixed
	P2	Green	45	45	Plate	Fixed
	P3	Silver	42	20	Sheet	Top Opening
	P4	Black	42	20	Sheet	Top Opening
W2	P1	Copper	34	48	Sheet	Horizontal Sliding
	P2	Green	34	48	Plate	Fixed
W3	P1	Copper	48	90	Plate	Fixed
	P2	Green	48	90	Plate	Fixed

\* A thin coat of paint was sprayed on both sides of each pane.

FRONT VIEW OF THREE MODULES INDICATING WINDOW TYPE AND PANE NUMBERS

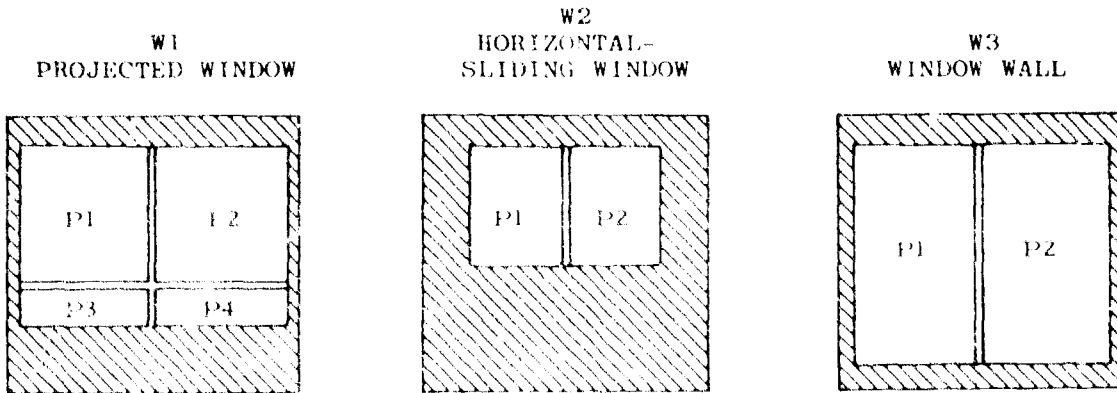

## Dummies

Two anthropomorphic dummies attired in summer civilian clothing were supplied by the Lovelace Foundation for this test. One of the dummies was standing 35 inches behind pane P2 in the B4 module at 3,525 feet. This module did not contain any Styrofoam witness plates. The dummy faced the window with his chest resting lightly against a narrow metal rod intended to stabilize his position prior to shock arrival while not interfering with subsequent possible blast displacement. The other dummy was secured by means of a lap seat belt in the driver's seat of a left-side on station wagon, A3, located at 2,115 feet on the northwest radial.

## Cameras

Two high-speed (400 frames per second) motion-picture cameras were used by China Lake personnel to record the responses of the two dummies. A reference grid was painted on the portion of the module wall in the field of view of the camera in order to facilitate velocity determinations for the glass fragments and the dummy.

## Overpressure Gauges

Eight self-recording BRL mechanical gauges, supplied by China Lake, were positioned, two each, at the 3,525-, 2,630-, and 2,115-foot ranges on the northwest radial and at the 2,115-foot range on the southwest radial. Additional gauges were located at closer ranges.

## RESULTS AND DISCUSSION

### General

All of the modules remained structurally intact and none of the Styrofoam witness plates were damaged or displaced by the blast experience. A total of 296 fragments were trapped from the 18 of 26 exposed panes which broke. Window damage was noted in four of the ten automobiles on the layout, but none of the windows broke in front of the witness plates. Dummy and glass responses were satisfactorily documented with both motion-picture cameras. Good pressure-time records were obtained from most of the gauges. In general, the average measured peak incident overpressures were close to the predicted values as given in Figure 1 for the five ranges of interest. The average measured overpressure was 0.60 psi at 3,525 feet (0.6 predicted), 0.97 psi at 2,630 feet (0.9 predicted), and 1.38 psi at 2,115 feet (1.2 predicted).

### Windows in Modules

The 26 panes of glass exposed in the modules are listed in Table II along with such information as glass thickness, whether or not the pane broke, and the number of fragments trapped.

TABLE II  
FRAGMENT DATA FOR THE WINDOWS IN THE MODULES

Ground Range, ft	Pi, ps	Pi, ps	tp, usec	Module Number	Window Type	Pane Number	Class Thickness, in.	Number of Trapped Fragments	V50, ft/sec	M50, gm	A50, in.2	E50, or E5a	b	Exh	Egv	Pd, frags. per ft2	Pw, frags. per ft2		
				B1	W2	P1* P2	0.236 0.239	0 9	37.8	16.8	1.71	3.54	-0.321	0.0650	1.42	0	1.11		
				B2	W3	P1 P2	0.239 0.239	25 21	60.8 40.3	10.8 22.0	1.12 2.27	4.88 4.37	-0.290 -0.192	0.0413 0.0765	1.38 1.66	2.84 1.77	2.31		
3125	0.6	1.2	250	B3	W1	P1 P2 P3 P4	0.235 0.232 0.125 0.125	20 5 52 35	40.1 51.1 78.0 68.6	11.6 10.5 0.877 1.40	1.22 1.12 0.173 0.277	5.57 5.01 4.11 4.88	-0.222 -0.218 -0.232 -0.282	0.0557 0.138 0.0392 0.0315	1.52 1.56 1.49 1.34	2.81 0.443 3.87 4.21	5.76		
				B4	W2	P1* P2*	0.236 0.236	** **	29*	-	-	-	-	-	-	-	-		
				Data from B1, B2, and B3 combined			0.125 0.238	87 90	74.1 45.1	1.06 14.2	0.209 1.47	4.45 4.61	-0.255 -0.257	0.0257 0.0294	1.43 1.53	5.10 1.68			
				B5	W3	P1 P2	0.232 0.232	4 12	21.7 53.6	61.3 12.1	6.52 1.29	1.51 4.66	-0.269 -0.230	0.225 0.0736	1.17 1.46	2.591 1.62	1.11		
			260	B6	W1	P1 P2 P3* P4	0.239 0.236 0.124 0.122	0 0 0 46	25.4 -	24.9 -	2.57 -	2.91 -	-0.064 -	0.126 -	1.59 -	1.44 0 0	2.36		
				B7	W2	P1 P2	0.236 0.234	0 8	39.5	10.6	1.12	12.9	-0.173	0.0388	1.30	0	0.517		
				Data from B5, B6, and B7 combined			0.122 0.235	46 37	47.1 35.0	2.91 18.0	0.589 1.89	3.24 5.19	-0.194 -0.218	0.0401 0.0454	1.37 1.57	2.60 0.775			
				B8	W3	P1* P2*	0.236 0.236	0 0	-	-	-	-	-	-	-	0 0	0		
			290	B9	W1	P1 P2 P3* P4*	0.239 0.236 0.124 0.124	1 0 0 0	16.7	21.5	2.22	-	-	-	-	-	0.222 0 0 0	0.111	
				B10	W2	P1 P2*	0.203 0.235	6 0	22.6	35.5	4.32	3.93	-0.110	0.107	1.39	0.886 0	0.443		
				Data from B8, B9, and B10 combined			0.124 0.208	0 7	21.6	33.0	3.92	3.54	-0.094	0.105	1.39	0 0.148			
								Total Number of Trapped Fragments										267*	

\* This pane did not break  
 \*\* There was no Styrofoam in the module containing this pane.  
 \* Velocity estimated from the motion-picture record (413 frames per second).  
 † Overall, an additional 29 fragments were trapped for which M and V were not calculated (see text) bringing the total number of fragments trapped to 296



FIGURE 2. Postshot View of (From Left to Right) Modules B5, B6, and B7.

Eight of the ten panes at 3,525 feet, seven of the eight panes at 3,950 feet, and three of the eight panes at 5,920 feet broke. As expected, only a portion of the glass from the broken panes was actually trapped. This is indicated by the amount of glass left in the frames and the number of fragments on the floor below the Styrofoam as shown in Figure 2, a postshot view of the modules at 3,950 feet. Table II also contains the predicted peak incident overpressure,  $P_i$ ; the calculated (using  $P_i$ ) peak overpressure in the reflected wave at the front of the modules,  $P_r$ ; and the predicted duration of the positive phase of the incident overpressure,  $t_p$ .

### Masses and Velocities of Fragments

The masses and velocities were determined by procedures described in Reference 3 for all but 29 fragments which struck so close to other fragments that the measured volumes of the impressions in the Styrofoam were suspect. As in the past, it was noted that for each pane an approximately linear relationship existed between the logarithms of the velocities and the logarithms of the masses of the fragments. A least-squares linear-regression analysis was performed for each pane and the results appear in Table II where  $V_{S0}$  and  $M_{S0}$  are the geometric mean fragment velocity and mass, respectively;  $b$  and  $F_b$  are the slope and the standard error in the slope of the regression line, respectively; and  $F_{Kv}$  is the geometric standard error of estimate of fragment velocity. In addition,  $A_{S0}$  is the geometric mean frontal area of the fragments (calculated from the density and thickness of the glass and  $M_{S0}$ ), and  $F_{pm}$  and  $F_{pa}$  are the geometric standard deviation of the fragment masses and frontal areas, respectively.

It was noted that the masses and velocities of fragments from panes of approximately the same thickness and located at the same ground range tended to be very similar. Therefore the data were

combined into five groups (no 1/8-inch-thick fragments were trapped at 5,920 feet) representing panes approximately 1/4- or 1/8-inch-thick located at the 3,525-, 3,950-, or 5,920-foot ground range. These groups are shown in Figures 3 through 7 which contain regression lines as well as lines drawn one standard error of estimate on either side of the regression lines. The results of the regression analysis for each of the five groups are given in Table II where it can be noted that the mean fragment velocity estimated from the motion-picture record obtained at 3,525 feet was 29 ft/sec compared to 37.6 ft/sec measured from the witness plate behind a similar pane in module B1 at the same range.

### Spatial Densities of Fragments

All 296 fragments were used in computing the spatial densities of trapped fragments which, for each pane, tended to be constant over an area of Styrofoam equal to the size of the pane. This area was, in general, centered somewhat below the center of the pane as a result of the fragments' having fallen (due to gravity) in traversing the distance from the frame to the Styrofoam. Likewise, the density of trapped fragments for an entire window (i.e., counting the fragments from all of the panes) tended to be approximately constant over an area of Styrofoam equal in size to the window but displaced downward. The computed average densities (designated as  $\rho_d$  and  $\rho_w$  for the individual panes and entire windows, respectively) over these areas of approximately constant density are listed in Table II.

### Comparisons With Prior Data

In order to make comparisons between the ESKIMO II and III tests and prior experiments, all of the data were plotted in Figures 8 through 10 which were modified from Reference 1. In these figures, it can be seen that the fragment velocities, frontal areas, and densities for the two ESKIMO tests were fairly consistent, indicating that these quantities were not greatly dependent on the yield. Further, the ESKIMO test data line up reasonably well with the corresponding values for the prior data when plotted against the effective peak overpressure, i.e., the peak overpressure on the window. This overpressure was assumed to be  $P_r$  for the ESKIMO tests since all of the windows faced the advancing blast wave. However, on all three figures the ESKIMO test data tend to fall above the regression curve based on the prior data only. Thus, the ESKIMO test data suggest that in each case the shape of the regression curve may need to be modified for the lower overpressures. In the case of the mean fragment velocity, this is probably because the fragments with sufficiently low velocities are not likely to be trapped in the Styrofoam.

### Biological Hazards

Figures 3 through 7 contain curves indicating the probability of a fragment's penetrating 1 cm of soft tissue as given in Reference 4. It can be seen that, of the 267 trapped fragments for which masses and velocities are available, only three had at least a 1.0-percent probability of penetrating 1 cm of soft tissue. All three occurred at the 3,525-foot range where fragments were trapped behind eight panes, giving an average of about one fragment for each two panes with a significant (at least

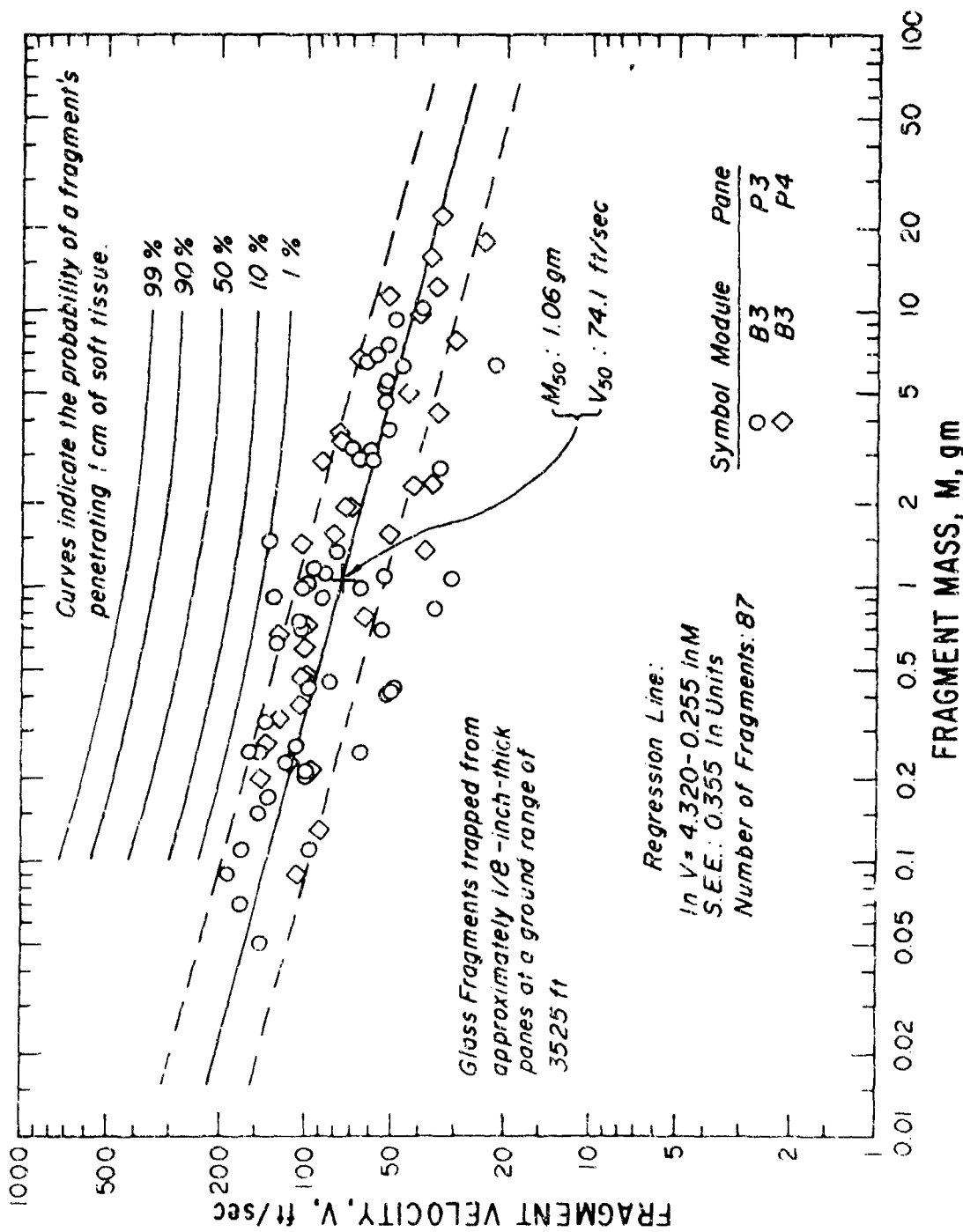

FIGURE 3. Glass Fragments Trapped From Approximately 1/8-Inch-Thick Panes at a Ground Range of 3,525 Feet.

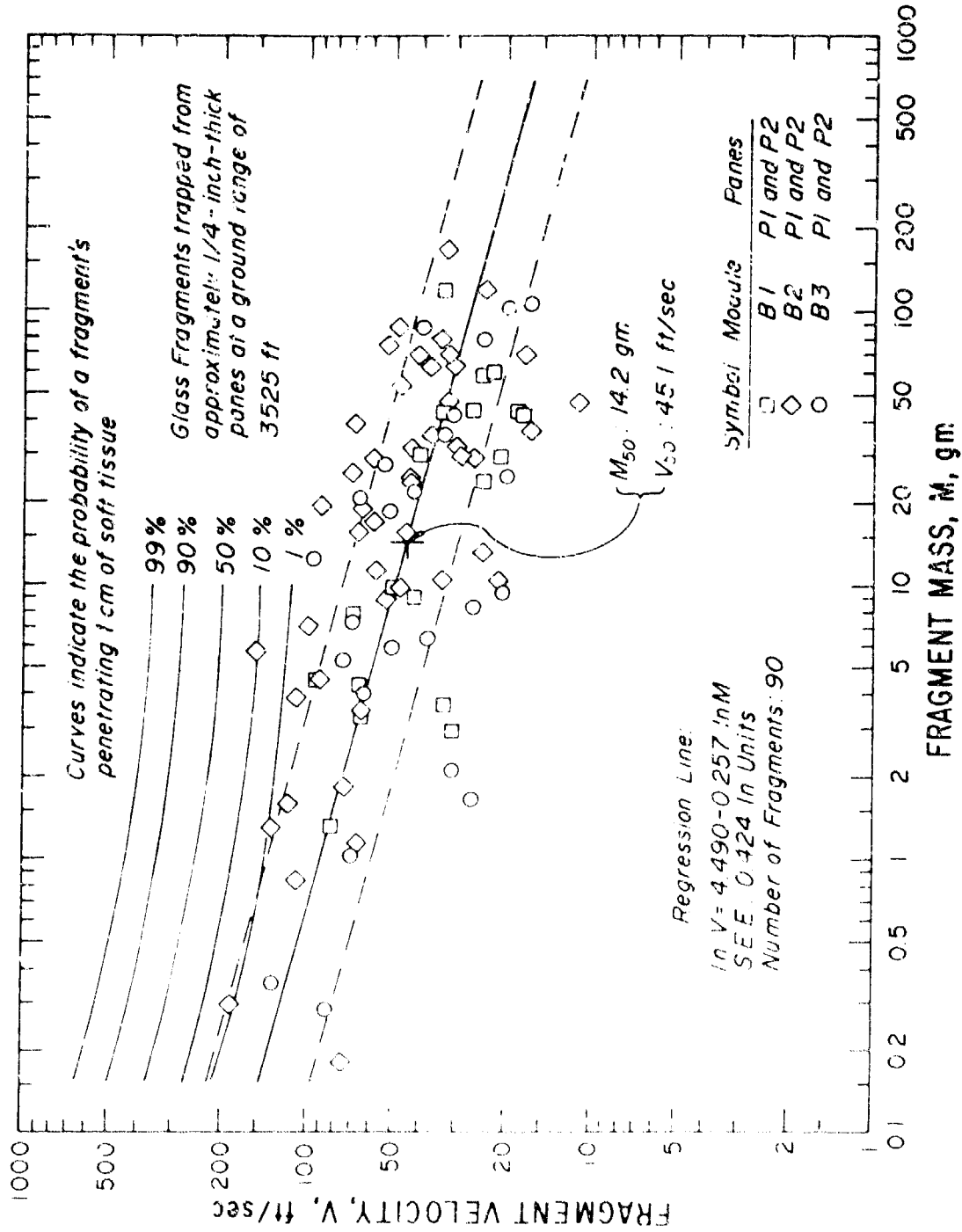

FIGURE 4. Glass Fragments Trapped From Approximately 1/4-Inch-Thick Panes at a Ground Range of 3,525 Feet.

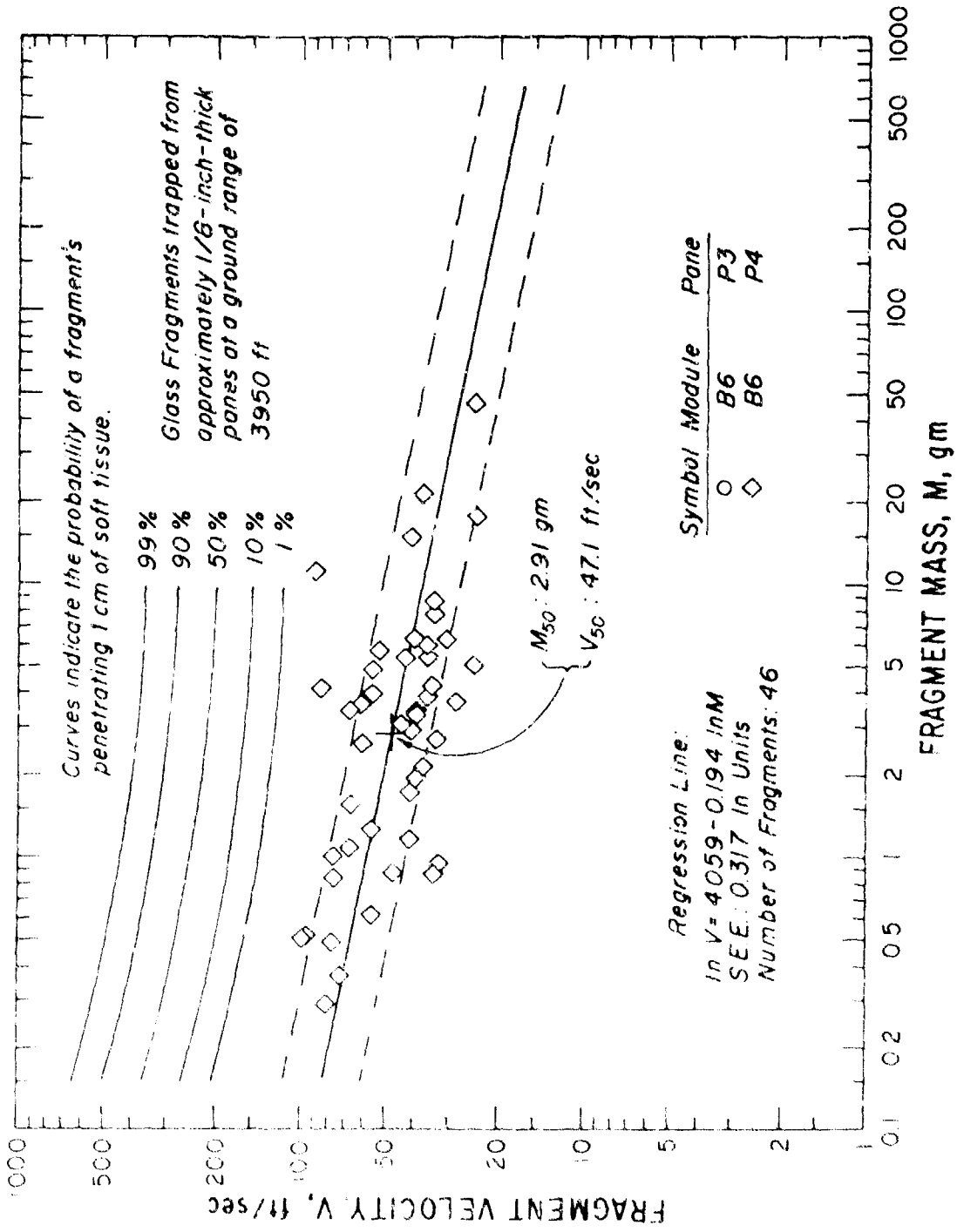

FIGURE 5. Glass Fragments Trapped From Approximately 1/8-Inch-Thick Panes at a Ground Range of 3950 Feet.

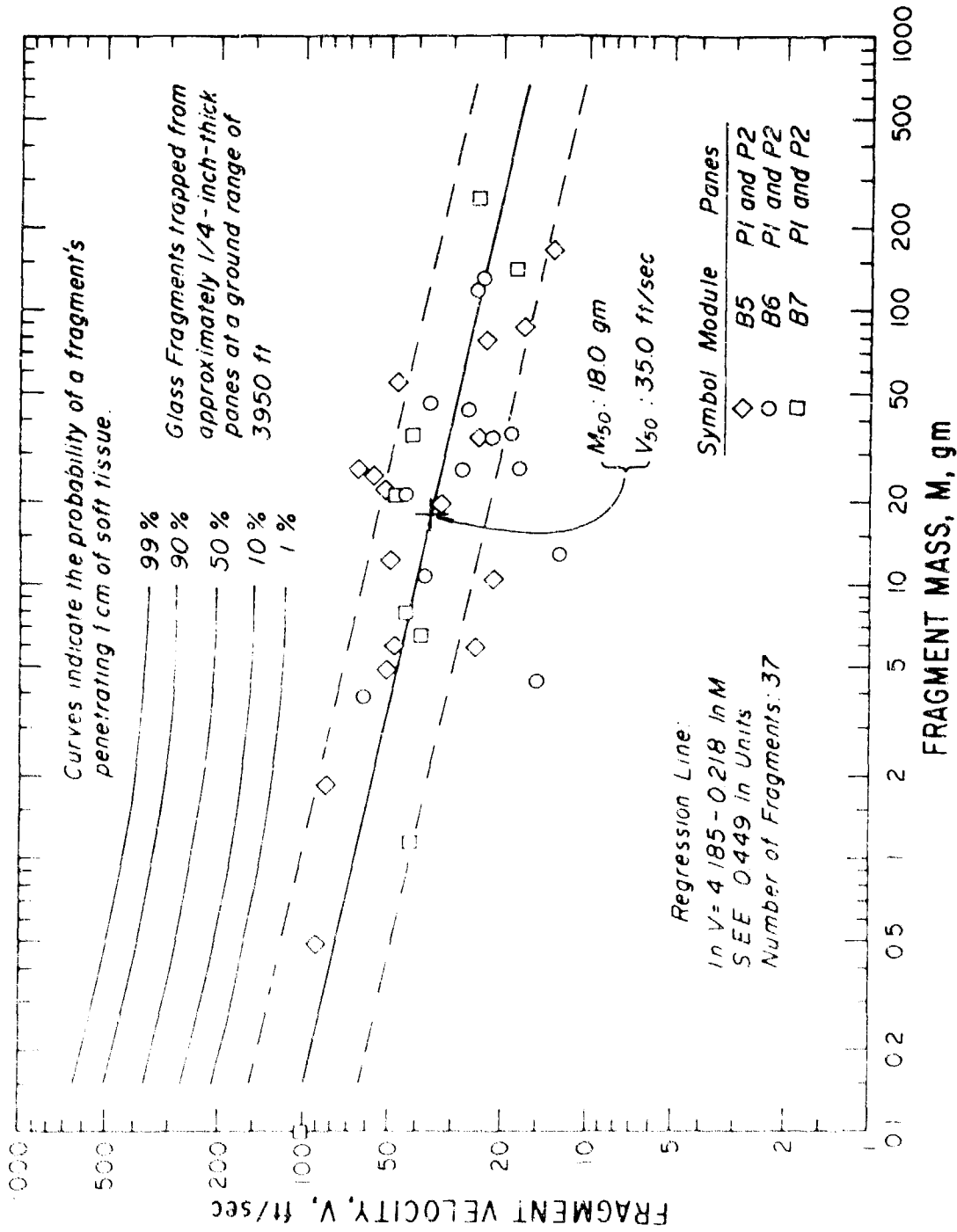

FIGURE 6. Glass Fragments Trapped From Approximately 1/4-Inch-Thick Panes at a Ground Range of 3950 Feet.

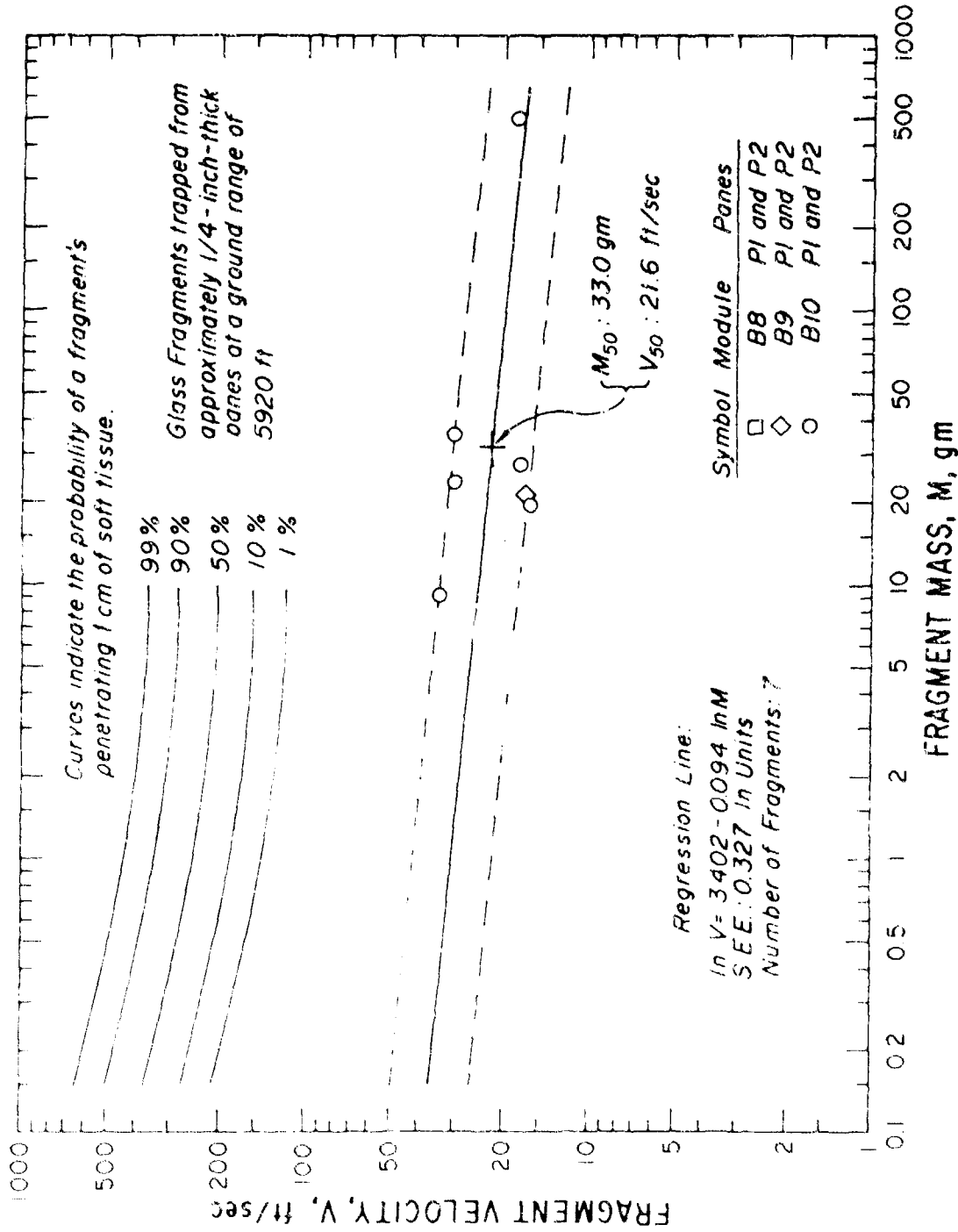

FIGURE 7. Glass Fragments Trapped From Approximately 1/4 Inch-Thick Panes at a Ground Range of 5920 Feet.

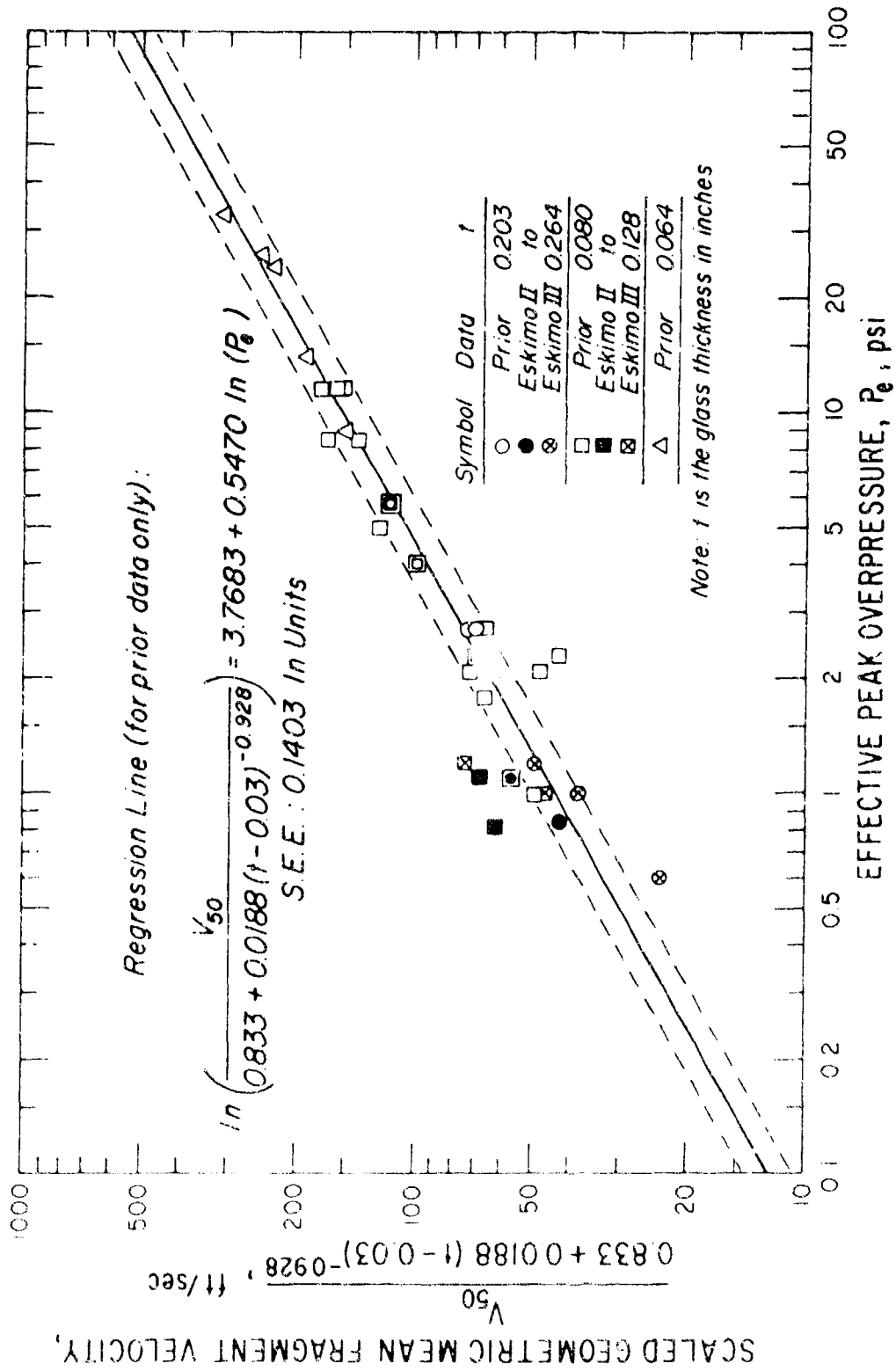

FIGURE 8. Scaled Geometric-Mean Fragment Velocity Versus Effective Peak Overpressure.

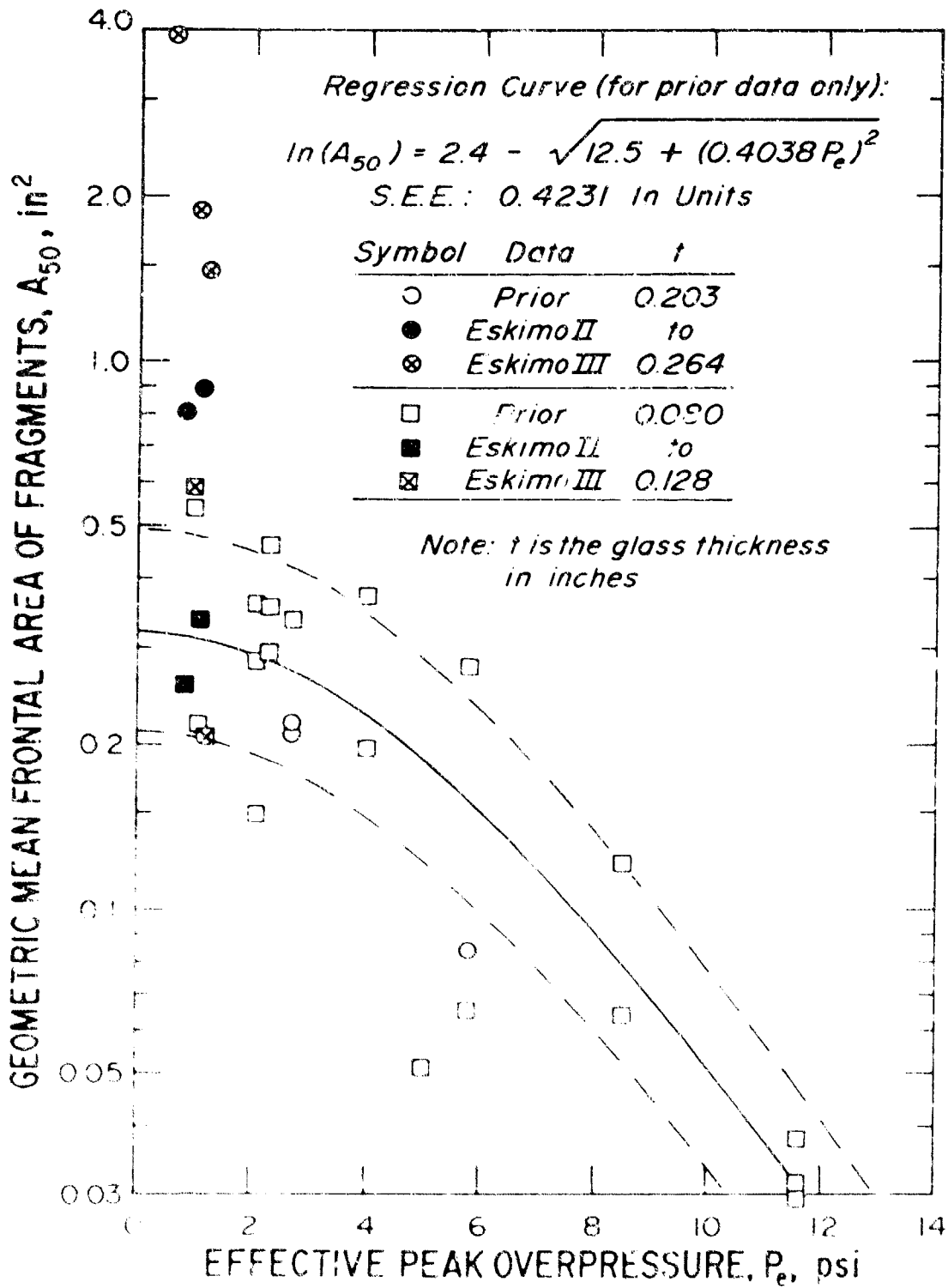

FIGURE 9. Geometric Mean Frontal Area of Fragments Versus Effective Peak Overpressure

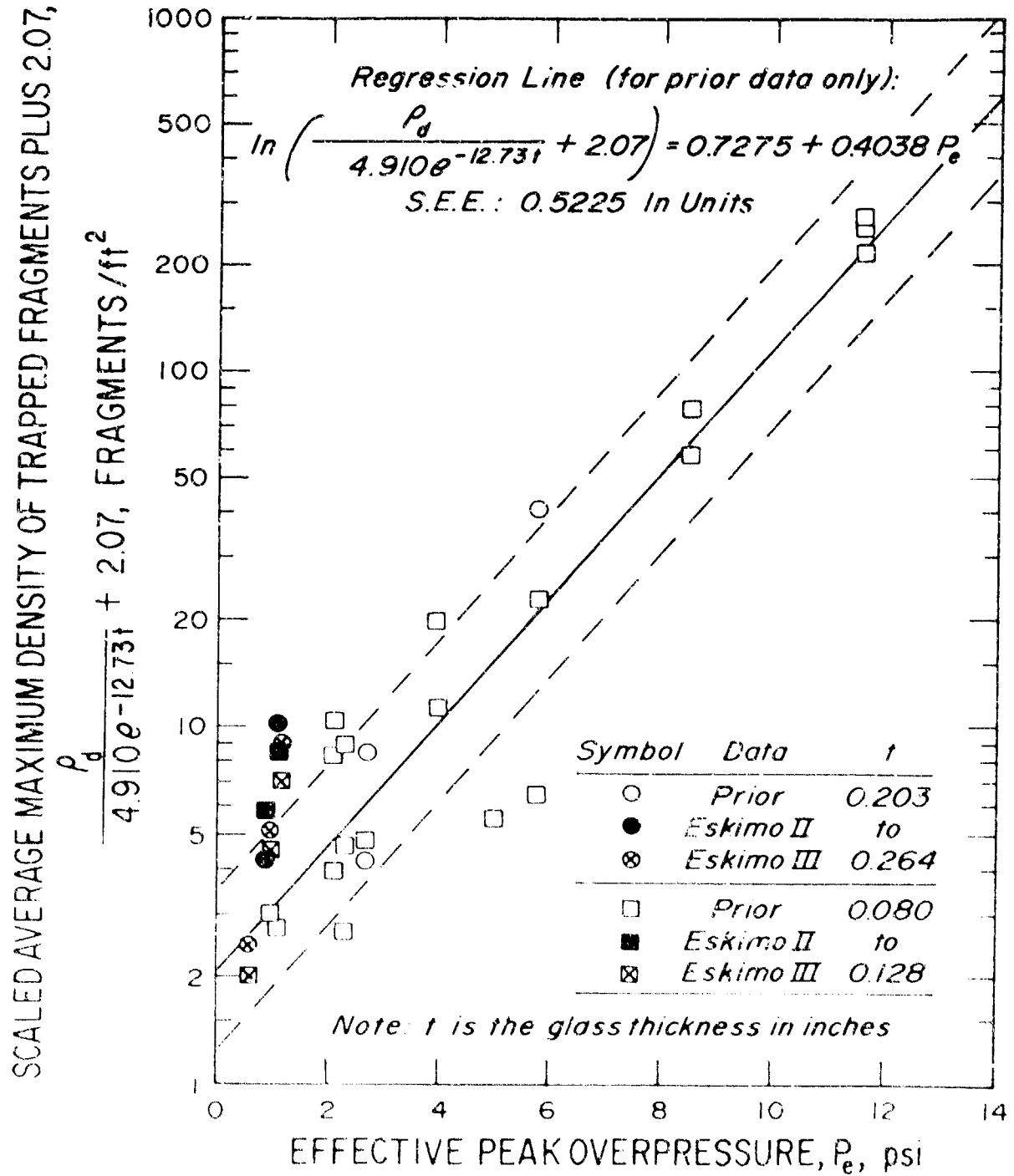

FIGURE 10. Scaled Average Maximum Density of Trapped Fragments Plus 2.07 Versus Effective Peak Overpressure

1.0 percent) probability of penetrating 1 cm of soft tissue. The highest probability computed at this range was 11 percent. No fragments with a significant probability of penetrating 1 cm of soft tissue were caught behind the sixteen panes at the 3,950- and 5,920-foot ranges.

Data from two biological studies were used to estimate the probability of skin penetrations by fragments trapped from the windows in the modules. In the first study (Reference 5) glass fragments (0.054 to 1.9 gm) were impacted in random orientations, and in the second study plexiglas fragments (1.0 to 100 gm) were impacted point-on. The velocity for a 50-percent probability of bare-skin penetration varied from 480 ft/sec for a 0.054-gm fragment to 33 ft/sec for a 100-gm fragment. The velocity for a 1.0-percent probability of bare-skin penetration varied from 200 ft/sec for a 0.054-gm fragment to 22 ft/sec for a 100-gm fragment. Limited data from the second study indicated that the above velocities should be increased by  $65 \pm 15$  percent for skin covered with two layers of light clothing. Using the above values, the numbers of fragments with greater than a 1.0- and 50-percent probability of penetrating bare skin and skin covered with two layers of light clothing were counted in Figures 3 through 7, and the results appear in Table III. Although some of the assumptions needed to derive Table III might be questioned, the values strongly suggest that a significant number of skin penetrations might have occurred had people been located behind the windows in the modules during the ESKIMO III event.

### Dummy in Module

The window pane (P2) 35 inches in front of the dummy was not broken by the blast wave. From the motion-picture record it was determined that no fragment from pane P1, which did break, struck the dummy and that the dummy suffered no displacement during the blast experience. At postshot examination, the dummy and clothing were found to be intact.

TABLE III  
PREDICTED SKIN PENETRATIONS BY FRAGMENTS  
FROM THE WINDOWS IN THE MODULES

Ground Range, Ft	Predicted Peak Overpressure, psi		Average Glass Thickness, Inches	Percent of Trapped Fragments With Greater Than A (1%/50%) Probability of Penetrating	
	Incident	Reflected		Bare Skin	Skin and Two Layers of Light Clothing
3525	0.6	1.2	0.125	67/10	7/0
			0.238	71/36	29/6
3950	0.5	1.0	0.122	37/4	4/0
			0.235	54/16	11/0
5920	0.3	0.6	0.208	14/0	0/0

## Windows in Automobiles

The locations of the automobiles on the layout are indicated in Figure 1, and the observed window damage is given in Table IV. At 2,115 feet (1.2 psi) the most common damage was to the larger windows such as the windshield. On the average, about one window per automobile was damaged, of which approximately one half broke out and one half sustained multiple cracks but remained in place. The only window damage sustained by the two automobiles at 2,630 feet (0.9 psi) consisted of multiple fractures of one windshield. None of the windows in the automobile at 3,950 feet (0.5 psi) were damaged. There was evidence that four automobile windows were broken

TABLE IV  
AUTOMOBILE WINDOW DAMAGE

Ground Range, ft	Pi, psi	Automobile			Windows Damaged	Extent of Window Damage
		Orientation	Number	Description		
2115	1.2	Face-On	A1†	Peugeot Station Wagon	None	None
			A2‡	Chevrolet Pickup	None	None
		Left Side-On	A3	Buick* Station Wagon	Windshield Left Rearward** Rear	Multiple fractures Intact but dislodged Partly broken out
			A4‡	Dodge Station Wagon	Windshield† Right Rear-Door Rear	Completely broken out Multiple fractures Completely broken out
			A5	Dodge Fuel Truck	Right Door	Multiple fractures
			A6	VW	None	None
			A7	Rambler Station Wagon	None	None
2630	0.9	Left Side-On	A8	VW Square Back	Windshield	Multiple fractures
			A9	Chevrolet Station Wagon	None	None
3950	0.5	Left Side-On	A10	Ford Station Wagon	None	None

\* An anthropomorphic dummy was secured in the driver's seat of this station wagon by means of a lap seat belt.

\*\* Analysis of the film record from the camera (392 frames per second) indicated that the window achieved a peak velocity of 12 ft/sec.

† The windshield had multiple fractures prior to the test.

‡ No missile impacts were noted on the Styrofoam witness plate which faced ground zero in this vehicle.

Note:  
Window damage due to bomb fragments or crater ejecta has not been included in the table.

by bomb fragments or crater ejecta rather than by the airblast itself. This damage was not included in Table IV.

The window which dislodged from the frame in automobile A3 traveled across the field of view of the motion-picture camera. From analyzing the record, it was determined that the peak velocity of the center of mass of the pane was about 12 ft/sec. Because of the low velocity and the fact that the glass did not break and produce sharp edges, it is estimated that the pane would have a very small probability of penetrating 1 cm of soft tissue. Although the pane was quite massive, it would probably not be very hazardous from the point of view of blunt-body trauma because of the low velocity.

### Dummy in Automobile

No damage was observed to the dummy secured by means of a lap seat belt in the driver's seat of the left-side-on station wagon (A3) at 2,115 feet (1.7 psi). The window behind the left rear door was blown into the vehicle, but it did not strike the dummy. From the motion-picture record it was determined that the dummy suffered no significant displacement during the blast experience.

### REFERENCES

1. Fletcher, E. R., Richmond, D. R., and Jones, R. K., "Velocities, Masses, and Spatial Distributions of Glass Fragments from Windows Broken by Airblast," Defense Nuclear Agency Report in preparation.
2. Fletcher, E. R., Richmond, D. R., and Jones, R. K., "Airblast Effects on Windows in Buildings and Automobiles on the Eskimo II Event," pp. 251-275, Volume I, Minutes of the Fifteenth Explosives Safety Seminar, sponsored by the Department of Defense Explosives Safety Board, Washington, D. C., September 1973.
3. Fletcher, E. R., Richmond, D. R., Bowen, I. G., and White, C. S., "An Estimation of the Personnel Hazards from a Multi-Ton Blast in a Coniferous Forest," Final Report, DASA 2020, Defense Nuclear Agency, Department of Defense, Washington, D. C., November 1967.
4. Glasstone, S. (Editor), "The Effects of Nuclear Weapons," U. S. Government Printing Office, Washington, D. C., April 1962.
5. Bowen, I. G., Richmond, D. R., Wetherbe, M. B., and White, C. S., "Biological Effects of Blast from Bombs, Glass Fragments as Penetrating Missiles and Some of the Biological Implications of Glass Fragmented by Atomic Explosions," USAEC Technical Report, AUC-3350, Office of Technical Services, Department of Commerce, Washington, D. C., June 18, 1956.