

**Best Available
Copy
for all Pictures**

U.S. DEPARTMENT OF COMMERCE
National Technical Information Service

AD-A027 206

BONDED FIELD-REPLACEABLE ROTOR BLADE POCKET FOR
THE CH-54B

VOLUME 1. DESIGN STUDY

UNITED TECHNOLOGIES CORPORATION

PREPARED FOR
ARMY AIR MOBILITY RESEARCH AND DEVELOPMENT
LABORATORY

JUNE 1976

209088

USAAMRDL-TR-75-25A



BONDED FIELD-REPLACEABLE ROTOR BLADE POCKET

FOR THE CH-54B

Volume I - Design Study

Sikorsky Aircraft Division
United Technologies Corporation
Stratford, Conn. 06497

ADA 027206

June 1976

Final Report

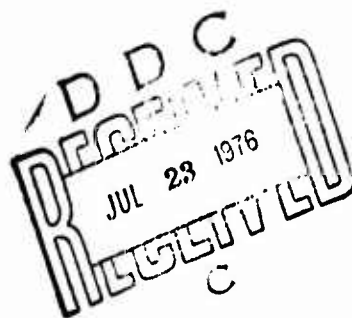

Approved for public release;
distribution unlimited.

Prepared for

EUSTIS DIRECTORATE

U. S. ARMY AIR MOBILITY RESEARCH AND DEVELOPMENT LABORATORY

Fort Eustis, Va. 23604

REPRODUCED BY
NATIONAL TECHNICAL
INFORMATION SERVICE
U. S. DEPARTMENT OF COMMERCE
SPRINGFIELD, VA. 22161

EUSTIS DIRECTORATE POSITION STATEMENT

This report is presented in two volumes. Volume I provides a discussion of the purpose and objective of the study together with a description of the design and fabrication efforts and the results of a 6-month field service evaluation. Volume II is the instruction manual for the bonded field-replaceable rotor blade pocket.

This effort is one of several related activities conducted by this Directorate leading to the definition of improved field repairability of helicopter rotor blades. USAAMRDL Technical Report 72-69, dated February 1973, describes the field-replaceable pocket concept that was evaluated under this contract.

This report has been reviewed by the Eustis Directorate and is considered to be technically sound. Specifically, the metal-to-metal bonding technique described in the report is believed to represent a significant technical achievement and indicates that metal blade field repairs can be much more extensive than presently allowed by Army maintenance practices. This Directorate is currently planning a program to examine nonpocket metal blade field repairability limits and preferred repair techniques; initiation is scheduled for late FY 76.

The technical monitor for this contract was Mr. Thomas E. Condon of the Military Operations Technology Division.

DISPOSITION INSTRUCTIONS

AVAILABILITY CODES

DISTRIBUTION

DISCLAIMERS

The findings in this report are not to be construed as an official Department of the Army position unless so designated by other authorized documents.

When Government drawings, specifications, or other data are used for any purpose other than in connection with a definitely related Government procurement operation, the United States Government thereby incurs no responsibility nor any obligation whatsoever; and the fact that the Government may have formulated, furnished, or in any way supplied the said drawings, specifications, or other data is not to be regarded by implication or otherwise as in any manner licensing the holder or any other person or corporation, or conveying any rights or permission, to manufacture, use, or sell any patented invention that may in any way be related thereto.

Trade names cited in this report do not constitute an official endorsement or approval of the use of such commercial hardware or software.

DISPOSITION INSTRUCTIONS

Destroy this report when no longer needed. Do not return it to the originator.

Unclassified

SECURITY CLASSIFICATION OF THIS PAGE (When Data Entered)

| REPORT DOCUMENTATION PAGE | | READ INSTRUCTIONS BEFORE COMPLETING FORM |
|--|--|--|
| 1. REPORT NUMBER USAAMRDL-TR-75-25A | 2. GOVT ACCESSION NO. | 3. RECIPIENT'S CATALOG NUMBER |
| 4. TITLE (and Subtitle) BONDED FIELD-REPLACEABLE ROTOR BLADE POCKET FOR THE CH-54B, Volume I - Design Study | 7. AUTHOR(s) John A. Longobardi | 5. TYPE OF REPORT & PERIOD COVERED Final Report |
| | | 6. PERFORMING ORG. REPORT NUMBER Sikorsky Engr. Report 64385 |
| 9. PERFORMING ORGANIZATION NAME AND ADDRESS Sikorsky Aircraft Division of United Aircraft Corporation Stratford, Connecticut 06497 | 11. CONTROLLING OFFICE NAME AND ADDRESS Eustis Directorate, U. S. Army Air Mobility Research and Development Laboratory Fort Eustis, Virginia 23604 | 8. CONTRACT OR GRANT NUMBER(s) DAAJ02-73-C-0076 |
| | | 10. PROGRAM ELEMENT, PROJECT, TASK AREA & WORK UNIT NUMBERS 63204A 1F163204DB38 00 017 EK |
| 14. MONITORING AGENCY NAME & ADDRESS (if different from Controlling Office) | 12. REPORT DATE June 1976 | 13. NUMBER OF PAGES 162 |
| | | 15. SECURITY CLASS. (of this report) Unclassified |
| 16. DISTRIBUTION STATEMENT (of this Report) Approved for public release; distribution unlimited. | | 16a. DECLASSIFICATION/DOWNGRADING SCHEDULE |
| 17. DISTRIBUTION STATEMENT (of the abstract entered in Block 20, if different from Report) | | |
| 18. SUPPLEMENTARY NOTES Volume I of a 2-Volume Report | | |
| 19. KEY WORDS (Continue on reverse side if necessary and identify by block number) CH-54B Repairable Blades Field Repairable Blades - CH-54B Installation of Field Replaceable Pockets on CH-54B Blades Maintenance of CH-54B Blades | | |
| 20. ABSTRACT (Continue on reverse side if necessary and identify by block number) The present CH-54B main rotor blade consists of 28 nonstructural, trailing-edge fairings called pockets. Fourteen of these pockets are different in dimension because of the taper on the blade spar. The adhesive retaining the pockets to the blade is a high-temperature and -pressure system. For these reasons, damaged pockets are repaired at the factory because of high inventory of pockets and sophisticated tooling for the heat-curing adhesive would be needed to make a field repair possible. | | |

DD FORM 1 JAN 73 1473 EDITION OF 1 NOV 65 IS OBSOLETE

Unclassified

SECURITY CLASSIFICATION OF THIS PAGE (When Data Entered)

Unclassified

SECURITY CLASSIFICATION OF THIS PAGE(When Data Entered)

ABSTRACT (continued)

Consequently, under previous contract with the Army (Contract DAAJ02-71-C-0022), the feasibility of developing a pocket and adhesive suitable for field application was investigated. The study resulted in a universal pocket design which could be utilized to replace any pocket on the CH-54B blade and an adhesive system which would cure at room temperature.

This program is a continuing effort of the work initiated under Contract DAAJ02-71-C-0022. It represents the improvements made to the universal pocket developed under the previous study, resulting in the field-replaceable pocket of the present program. An improved adhesive system, with higher fatigue strength, was also developed. The report encompasses the design, fabrication, testing, field evaluation, and cost analysis of the field-replaceable pocket.

Unclassified

SECURITY CLASSIFICATION OF THIS PAGE(When Data Entered)

PREFACE

The bonded field-replaceable rotor blade pocket program was performed under Contract DAAJ02-73-C-0076 with the Eustis Directorate, U. S. Army Air Mobility Research and Development Laboratory, Fort Eustis, Virginia, Project 1F163204DB38, and was under the general technical direction of Thomas Condon of the Military Operations Technology Division of the Eustis Directorate. This is a follow-on effort to Reference 1, the purpose of both programs being to obtain more cost effective blades by installing blade pockets in the field.

Sikorsky's principal participants were George Capowich, Pierce A. Meck, Barry W. P. Stocker, Harold Jacob, Lawrence A. Russell and James T. Maccomb from the Engineering Department, Robert S. Pavlech and John K. Duban from the Manufacturing Engineering Department, and Joseph Ozelski, Walter J. Spader, Kenneth G. Olin, Robert F. Maglione, Edward Teixeira and John Drzyzek from the Manufacturing Department. John A. Longobardi from the Engineering Department was the team program manager. The program was under the general supervision of Peter J. Arcidiacono, Rotor System Section Head.

TABLE OF CONTENTS

| | <u>Page</u> |
|---|-------------|
| PREFACE | 1 |
| LIST OF ILLUSTRATIONS | 4 |
| LIST OF TABLES. | 7 |
| INTRODUCTION. | 8 |
| FIELD-REPLACEABLE POCKET INVESTIGATIONS | 9 |
| ADHESIVE ENVIRONMENTAL QUALIFICATION TESTS. | 31 |
| ADHESIVE PACKAGING OPTIMIZATION | 43 |
| FIELD REPAIR KITS | 47 |
| POCKET STATIC AND DYNAMIC TESTS | 52 |
| FIELD INSTALLATION. | 107 |
| FIELD FLIGHT EVALUATION | 111 |
| COST ANALYSIS | 116 |
| CONCLUSIONS | 119 |
| RECOMMENDATION | 120 |
| REFERENCES CITED. | 121 |
| APPENDIXES | |
| A. Adhesive Proof Load Test Plan | 122 |
| B. Chemical Heat Pack Test Plan. | 127 |
| C. Fatigue Test Plan | 129 |
| D. Whirl Tower Test Plan | 139 |
| E. Flight Test Plan. | 149 |

Preceding page blank

LIST OF ILLUSTRATIONS

| <u>Figure</u> | | <u>Page</u> |
|---------------|--|-------------|
| 1 | EWR 38633 Field-Replaceable Pocket | 10 |
| 2 | Field-Replaceable Pocket Assembly | 11 |
| 3 | Universal Pocket Design. | 13 |
| 4 | Aluminum Skins/Solid Honeycomb Core Design | 15 |
| 5 | Aluminum Skins/Honeycomb Core Rib Design | 16 |
| 6 | Fiberglass Skins/Honeycomb Core Design | 17 |
| 7 | All-Aluminum Channel/Rib Design. | 18 |
| 8 | Backwall Spacer. | 21 |
| 9 | Outboard Backwall Spacers. | 22 |
| 10 | Bonding Fixture Assembly | 25 |
| 11 | Overlap Shear Test Specimen. | 32 |
| 12 | "T" Peel Specimen. | 33 |
| 13 | Shear Specimen Assembly Fixture. | 35 |
| 14 | Comparison of EA 9320 and 9309.2 Shear Strength. | 39 |
| 15 | Comparison of EA 9320 and 9209.2 Peel Strength | 40 |
| 16 | Minimum Peel and Shear Acceptable Cure Time. | 41 |
| 17 | Kneading Type Adhesive Package Showing Clamp Being Removed. | 44 |
| 18 | Plunger Type Adhesive Package. | 45 |
| 19 | Field-Replaceable Pocket Kit | 48 |
| 20 | Bonding Fixture Kit. | 49 |
| 21 | Bonding Fixture Installed on Blade | 51 |
| 22 | Pocket Specimen Fixtures | 53 |
| 23 | Pocket Proof Load Setup in Tensile Machine | 54 |
| 24 | Proof Load Test Comparison | 56 |

| <u>Figure</u> | | <u>Page</u> |
|---------------|--|-------------|
| 25 | Installing of Chemical Heat Packs for Pocket Bonding. . . | 58 |
| 26 | Temperature at Pocket-to-Spar Bond vs Time. | 59 |
| 27 | Typical Fatigue Specimen. | 62 |
| 28 | Cross Section Through Spar and Pocket | 63 |
| 29 | Specimen in 60K Lb Fatigue Test Machine | 64 |
| 30 | Specimen in 100K Lb Fatigue Test Machine. | 65 |
| 31 | Schematic of Blade Test Machine | 66 |
| 32 | Vibratory BR Stress vs Blade Pocket Position. | 68 |
| 33 | Damaging Cycles to Failure. | 71 |
| 34 | Damaging Cycles to Failure. | 72 |
| 35 | Damaging Cycles to Failure. | 73 |
| 36 | Damaging Cycles to Failure. | 74 |
| 37 | Blade Balance and Performance Summary | 80 |
| 38 | Blade Balance and Performance Summary | 81 |
| 39 | Blade Balance and Performance Summary | 82 |
| 40 | Blade Balance and Performance Summary | 83 |
| 41 | Blade Balance and Performance Summary | 84 |
| 42 | Blade Balance and Performance Summary | 85 |
| 43 | Trailing-Edge Tab | 86 |
| 44 | Installed Field-Replaceable Pockets | 88 |
| 45 | Configurations Flown - Looking Down From Top of Main Rotor. | 90 |
| 46 | Configuration 1 - Blade Stresses vs Airspeed. | 92 |
| 47 | Configuration 1 - Blade Stresses vs Airspeed. | 93 |
| 48 | Configuration 2 - Blade Stresses vs Airspeed. | 94 |
| 49 | Configuration 2 - Blade Stresses vs Airspeed. | 95 |

| <u>Figure</u> | | <u>Page</u> |
|---------------|--|-------------|
| 50 | Configuration 3 - Blade Stresses vs Airspeed. | 96 |
| 51 | Configuration 3 - Blade Stresses vs Airspeed. | 97 |
| 52 | Configuration 4 - Blade Stresses vs Airspeed. | 98 |
| 53 | Configuration 4 - Blade Stresses vs Airspeed. | 99 |
| 54 | Configurations 1 and 2 - Push Rod Loads vs Airspeed . . . | 100 |
| 55 | Configurations 3 and 4 - Push Rod Loads vs Airspeed . . . | 101 |
| 56 | Configurations 1 and 2 - Rotating Scissors Load vs Airspeed | 102 |
| 57 | Configurations 3 and 4 - Rotating Scissors Load vs Airspeed | 103 |
| 58 | Longitudinal Stick Position vs Airspeed | 104 |
| 59 | Lateral Stick Position vs Airspeed. | 104 |
| A-1 | Proof Load Test - Additional Paste Adhesive | 125 |
| A-2 | Static Proof Load Pocket Specimen | 126 |
| B-1 | Time to Cure EA 9320 Adhesive to 1000 PSI Shear Strength. | 128 |
| C-1 | Previous CH-54B Blade Gage Locations. | 132 |
| C-2 | Vibratory BR Stress Distribution. | 134 |
| C-3 | Adhesive Bond and Pocket Fatigue Specimen in a 100K Lb Test Machine | 135 |
| C-4 | Measurement of Pocket Bond Separation | 136 |
| C-5 | Inspection Summary Data Sheet | 138 |
| D-1 | 3,000 HP Blade Balance Test Stand | 142 |
| D-2 | 10,000 HP Main Rotor Test Stand | 143 |
| D-3 | CH-54B Rotorhead Power Usage Spectrum | 144 |
| D-4 | Flapping Spectrum | 145 |
| E-1 | Blade Strain Gage Locations | 152 |

LIST OF TABLES

| <u>Table</u> | <u>Page</u> |
|--|-------------|
| 1 Pocket Analysis | 19 |
| 2 EA 9320 Cure Time to Obtain Minimum Strengths | 36 |
| 3 Values Obtained With Hysol EA 9320 When Tested On Residual Material | 38 |
| 4 Proof Load Test Results | 55 |
| 5 Fatigue Test - Specimen Configuration | 62 |
| 6 Field-Replaceable Pocket Fatigue Data | 69 |
| 7 Spanwise Moment Summary | 77 |
| 8 Endurance Whirl Test Summary. | 79 |
| 9 Field-Replaceable Pocket Spanwise Moment Change | 106 |
| 10 Field-Replaceable Pockets Installed On CH-54B Main Rotor Blades. | 108 |
| 11 Peel Strength of EA 9320 Adhesive System With Proper and Improper Procedure. | 113 |
| 12 Results of Investigation of New Primer Base for EA 9320 Adhesive. | 114 |
| 13 Sensitivity Tests (AF 6 Adhesive Insensitive to Improper Procedure) | 115 |
| B-1 Time to Cure EA 9320 to 1000 PSI Shear Strength | 128 |
| C-1 CH-54B Pocket-to-Spar Adhesive Bond Fatigue Test Conditions . . | 133 |
| D-1 Endurance Test Conditions | 146 |
| E-1 Change in Blade Spanwise Moment | 153 |

INTRODUCTION

This report includes the results of design, fabrication and testing of field-replaceable pockets for CH-54B main rotor blades. These pockets were designed to be installed in any position along the blade spar by Army maintenance personnel in the field. The purpose of the program was to estimate the potential savings to the Army by eliminating the time and cost to return a damaged blade to an overhaul depot, reducing the number of spare blades, and increasing the availability of aircraft.

This is the second of two programs on field replaceable pockets. The first study, Reference 1, was also conducted by Sikorsky Aircraft, demonstrating the feasibility of the concept. A universal pocket was developed, fabricated and tested under that program, indicating the structural suitability of the pocket. An adhesive for bonding on these pockets at ambient temperatures was also developed under this contract; the adhesive was environmentally tested, and both pocket and adhesive were successfully subjected to proof load and fatigue tests.

The present field-replaceable pocket program is a continuation of the previous study; it made refinements and simplifications to the original pocket design and developed a newer, tougher adhesive. In addition to environmental tests on the new adhesive, proof load and fatigue tests were conducted on the new pocket and adhesive. Whirl tower tests and a flight test program were also conducted. Results showed that the pocket and adhesive were suitable for field use.

The program included development of a pocket repair kit containing essential components required to make a field repair and a field pocket repair instruction manual to facilitate installation by Army maintenance personnel. The bonding fixture tool of Reference 1 was simplified by eliminating some of the components and improved by adding the feature of multiple pocket replacement.

Trial installation of field-replaceable pockets was accomplished on CH-54B blades at Sikorsky Aircraft by Army maintenance personnel. After refinements were made to the field repair instruction manual, field-replaceable pockets were installed by Army personnel at Fort Wainwright, Alaska, and Fort Eustis, Virginia.

The final portion of the study included a cost analysis comparing the difference in cost between repairing CH-54 main rotor blades at the factory and main rotor blades repaired in the field with field-replaceable pocket kits.

FIELD-REPLACEABLE POCKET INVESTIGATIONS

DESIGN SELECTION - EWR 38633 POCKET

The purpose of this investigation was to optimize the existing universal pocket and to simplify or eliminate the shims and spacers developed under the previous study, Reference 1. The EWR 38633 pocket selected for the program was the result of several pocket configurations investigated. The conclusion was based on a trade-off of weight, complexity of field repair, structural integrity, and cost. All the designs investigated, including the universal pocket of Reference 1, are discussed below.

The feature of the EWR 38633 pocket is that it opens in a scissors fashion and is adjustable, thereby eliminating the side shims required with the universal pocket. It consists of aluminum outer skins and ribs with a triangular core of honeycomb in the aft portion of the pocket (Figures 1 and 2). Six ribs or (U-shaped channels) are structurally bonded to each panel skin. The two halves are then bonded together with the honeycomb core to form the pocket. The pocket is designed to the mean chordal thickness: i.e., outboard, the pocket is closed 1/8 inch for bonding to the spar; inboard, it is opened 1/8 inch for bonding to the spar. Therefore, this one pocket can be utilized at any position. All components except the -103 angle are bonded together with Hysol's Adhesive Tape EA 9602.3, at 250°F and 50 psi. The tape is used because it has high strength in shear and peel and is more convenient for assembly of many components. The tape weight is also closely controlled. The -103 leading-edge angle was installed with room temperature Hysol EA 9320 as a secondary operation to allow for removal of tooling from the primary bonding operation. The EA 9320 also has high shear and peel strength and is the adhesive used for installing replaceable pockets in the field.

OTHER DESIGNS INVESTIGATED

The universal pocket developed under Reference 1 was considered as the first design since considerable development had already been expended in the previous program. The design is simple, being very similar in construction to the production pocket. The only difference in design is that one-half of each outer skin is left unbonded for installation of side shims as required along various positions on the blade spar (Figure 3). Proof load and fatigue tests conducted under the original contract also indicated that this design was a valid approach.

However, there were some undesirable features of the universal pocket design. The primary objection was that the side shims required with this design complicated installation of the pocket. It required that up to two shims had to be installed during assembly. This is in addition to the existing backwall spacers which are required to maintain constant chordwise dimension. Having both side shims and backwall spacers increased the likelihood of error in making the proper selection of shims or spacer. This design also doubled the task and time for assembly; it required adhesive on the side shims and pocket sides in addition to the regular adhesive on the back of the spar and front sides of the pocket. It increased the



Figure 1. EWR 38633 Field-Replaceable Pocket.

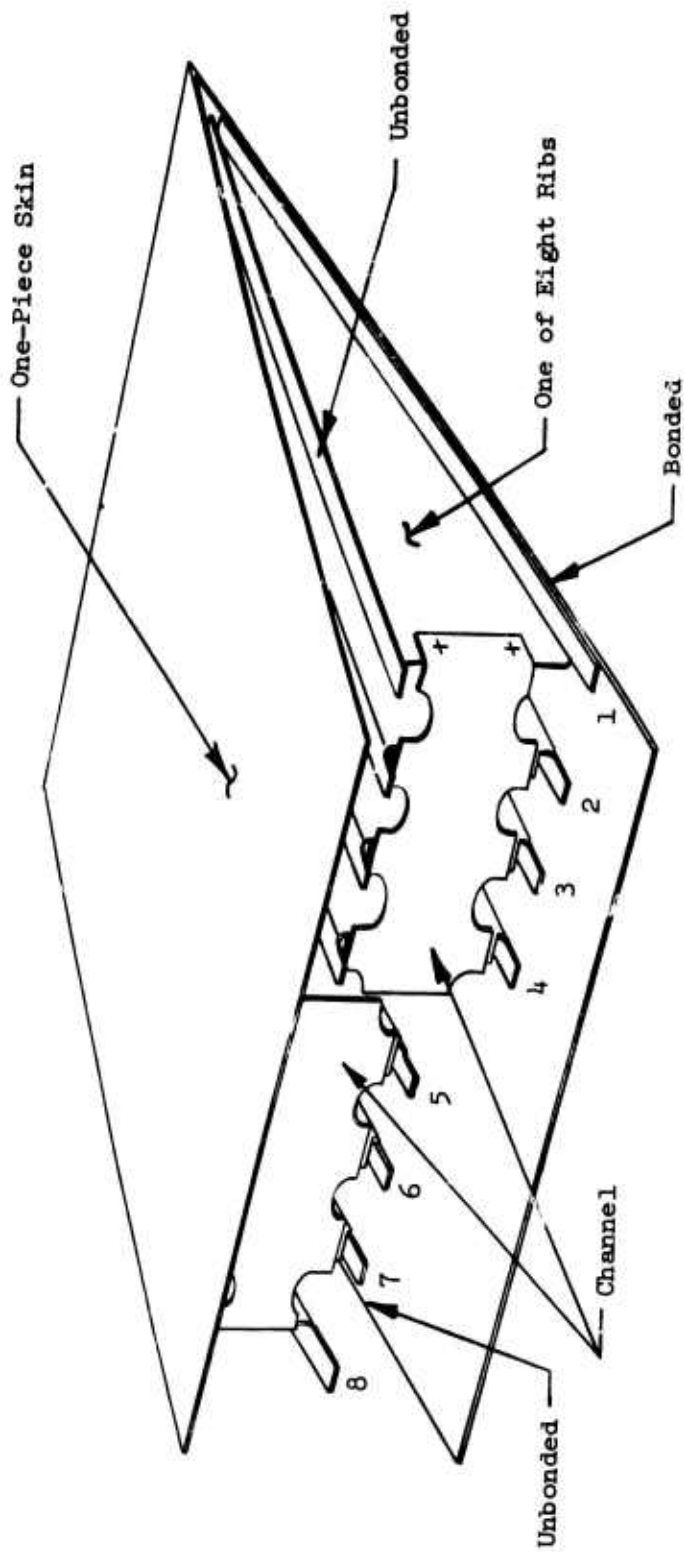

Figure 3. Universal Pocket Design.

Preceding page blank

possibility of improperly applying the adhesive and aligning the shims in place over the pocket ribs. Later experience in the program showed that the time element in applying the adhesive was extremely important. Any elimination of shims or spacers decreased the time to apply the adhesive and consequently enhanced the installation procedure. The shim and additional adhesive required increased the weight, especially on the inboard pockets, reducing the number of pockets replaceable on any blade.

All other designs investigated stressed elimination of the side shims. The first design (Figure 4) consisted of solid aluminum inner and outer skins sandwiched with complete blocks of nomex honeycomb core. This design was fabricated with soft tooling to obtain an actual weight and also to illustrate the scissor-type concept. Upon completion of fabrication, the pocket was shown to be feasible because it could be installed in any position on the backwall of the spar. The design was also structurally sound but was prohibitive because it was twice the weight of the present production pocket. The second design (Figure 5) was also fabricated with soft tooling. It was essentially the same as the first aluminum design except that sections of the honeycomb and the inner skins were removed to reduce pocket weight. The final weight was slightly higher than that of the production pocket. However, because it was representative, the pocket was proof loaded and failed at 900 lb. Investigation showed that reinforcement was needed at the trailing edge of the pocket to transfer shear load from one side panel to the other. A third design, Figure 6, consisted of inner and outer fiberglass skins filled with honeycomb core. Based on the proof load test of the second design (Figure 5), a triangular block of honeycomb was inserted in the third design (Figure 6) in the trailing edge of the pocket for shear load transfer. However, analysis showed that this design was not only heavy but also would be more expensive to fabricate than the aluminum skin/rib construction. Consequently, no trial fabrication was made of this configuration. Another design (Figure 7) was an all-aluminum channel/rib design. It consisted of two outer skins and eight inner channels equally spaced, acting as ribs. This was as light as the EWR 38633 design; however, analysis showed that because the inner leg of the ribs was unsupported, warpage could occur at low proof load. Consequently, no further effort was made toward this design.

TRADE-OFF

A comparative analysis of the six different configurations is presented in Table 1. The EWR 38633 was selected because it was structurally adequate and represented the lightest weight solution. The method of fabrication is fairly inexpensive, and the aluminum material and small amounts of nomex core represented small costs. It was estimated that the cost of this pocket design would be very close to the cost of a production pocket. The scissors action of the pocket allowed universal replacement and yet maintained close airfoil contour along any position on the spar. Figures 5 and 7 closely approach the EWR 38633 design except that structural reinforcement is necessary to strengthen each configuration. Material can be easily added to these designs, but then it becomes a weight problem. The greater the weight of the replaceable over the production pocket, the fewer the replaceable pockets that can be installed on any one blade because of spanwise and chordwise moments, pitching moments, and track considerations.

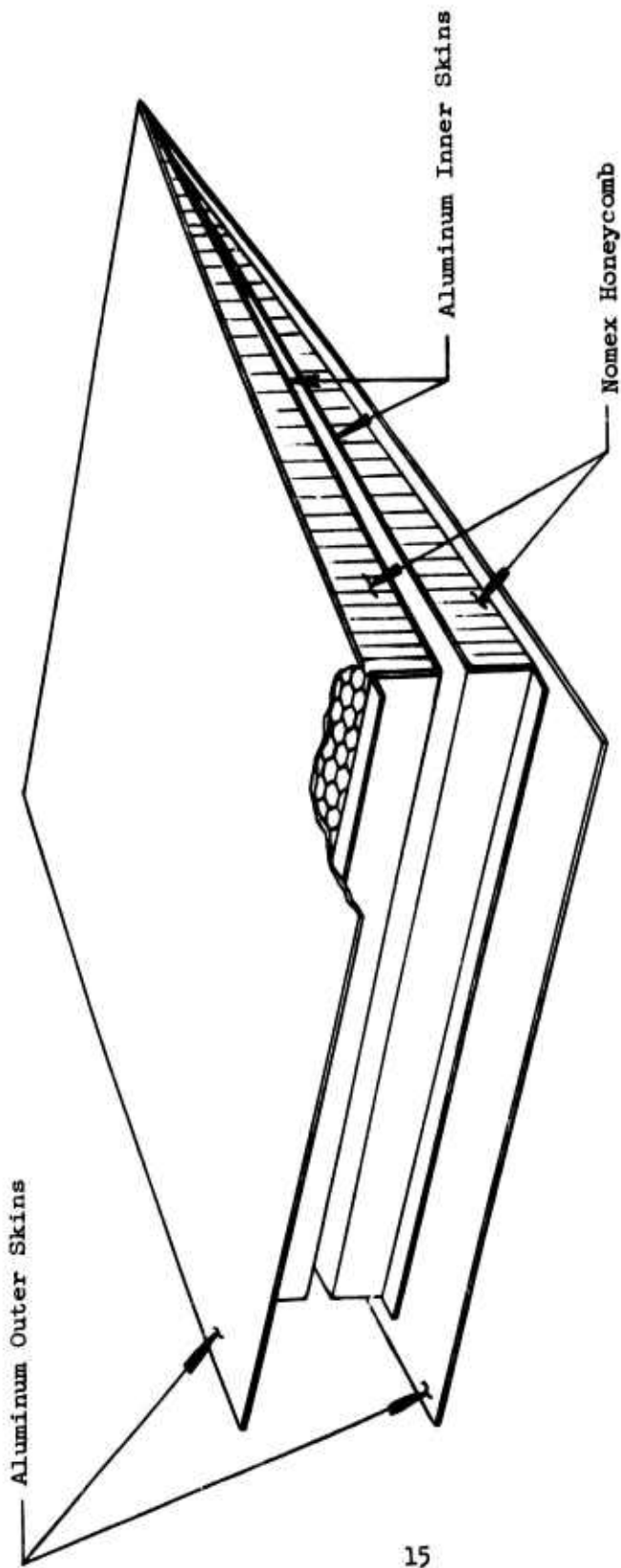

Figure 4. Aluminum Skins/Solid Honeycomb Core Design.

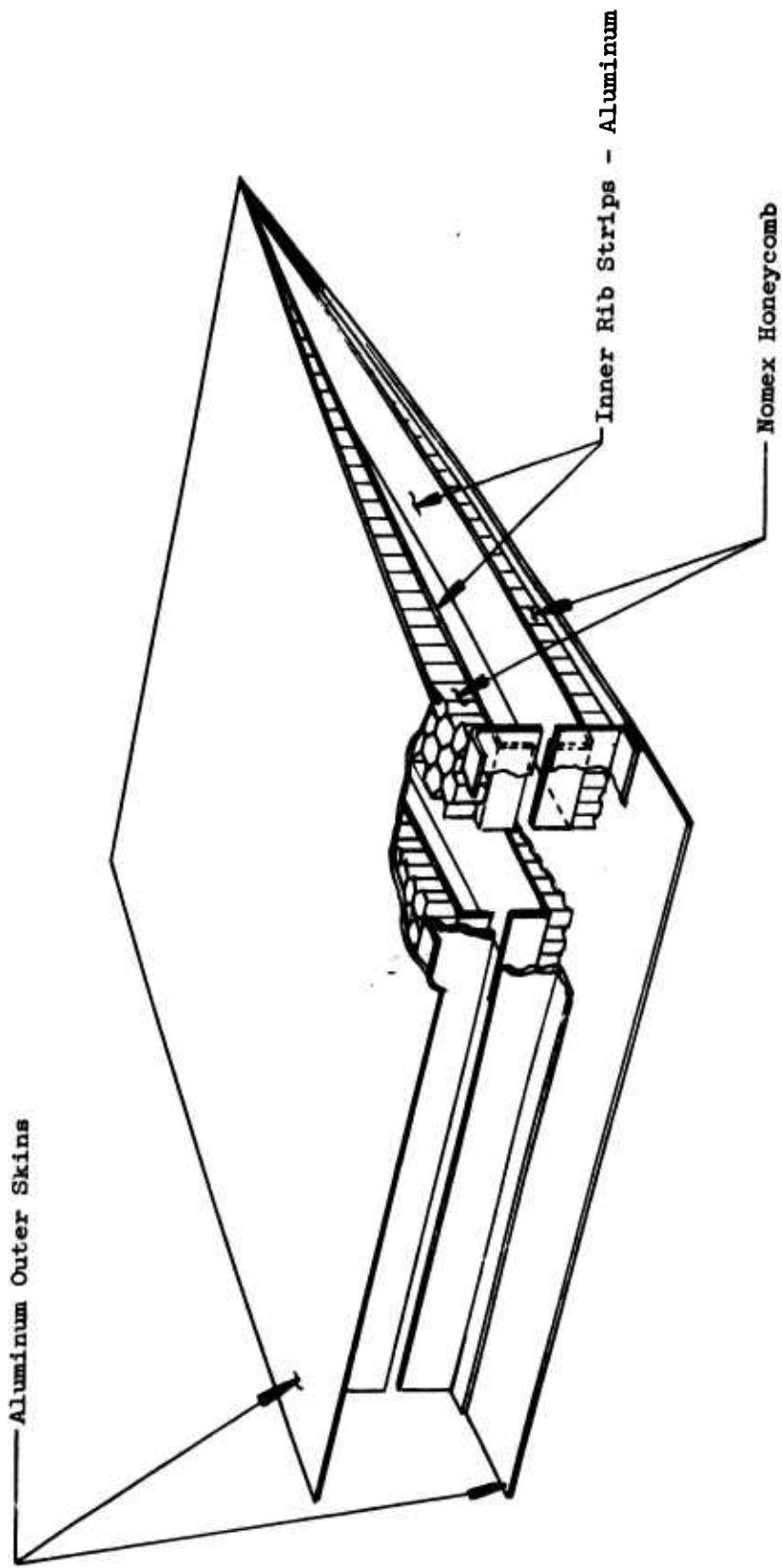

Figure 5. Aluminum Skins/Honeycomb Core Rib Design.

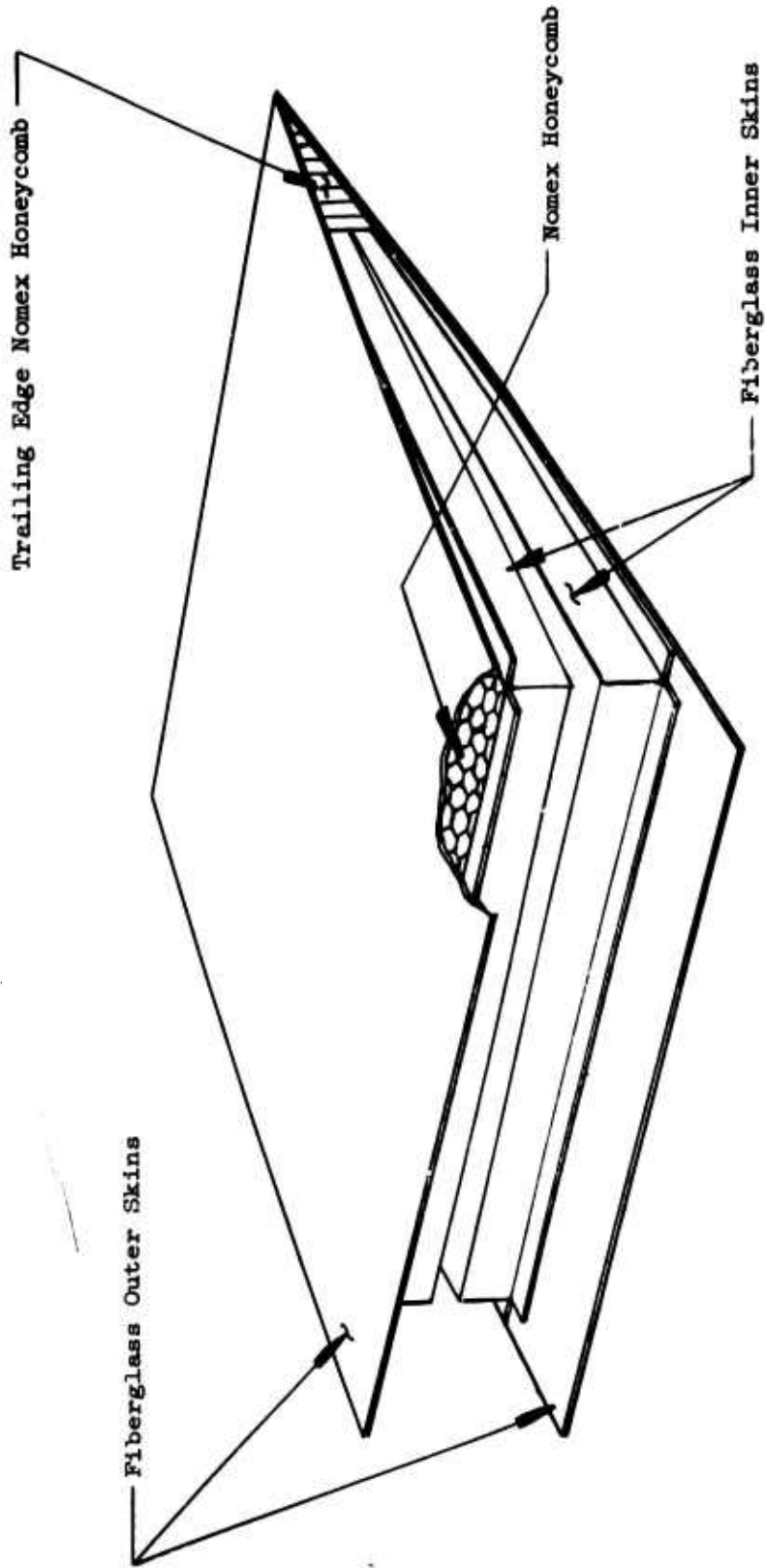

Figure 6. Fiberglass Skins/Honeycomb Core Design.

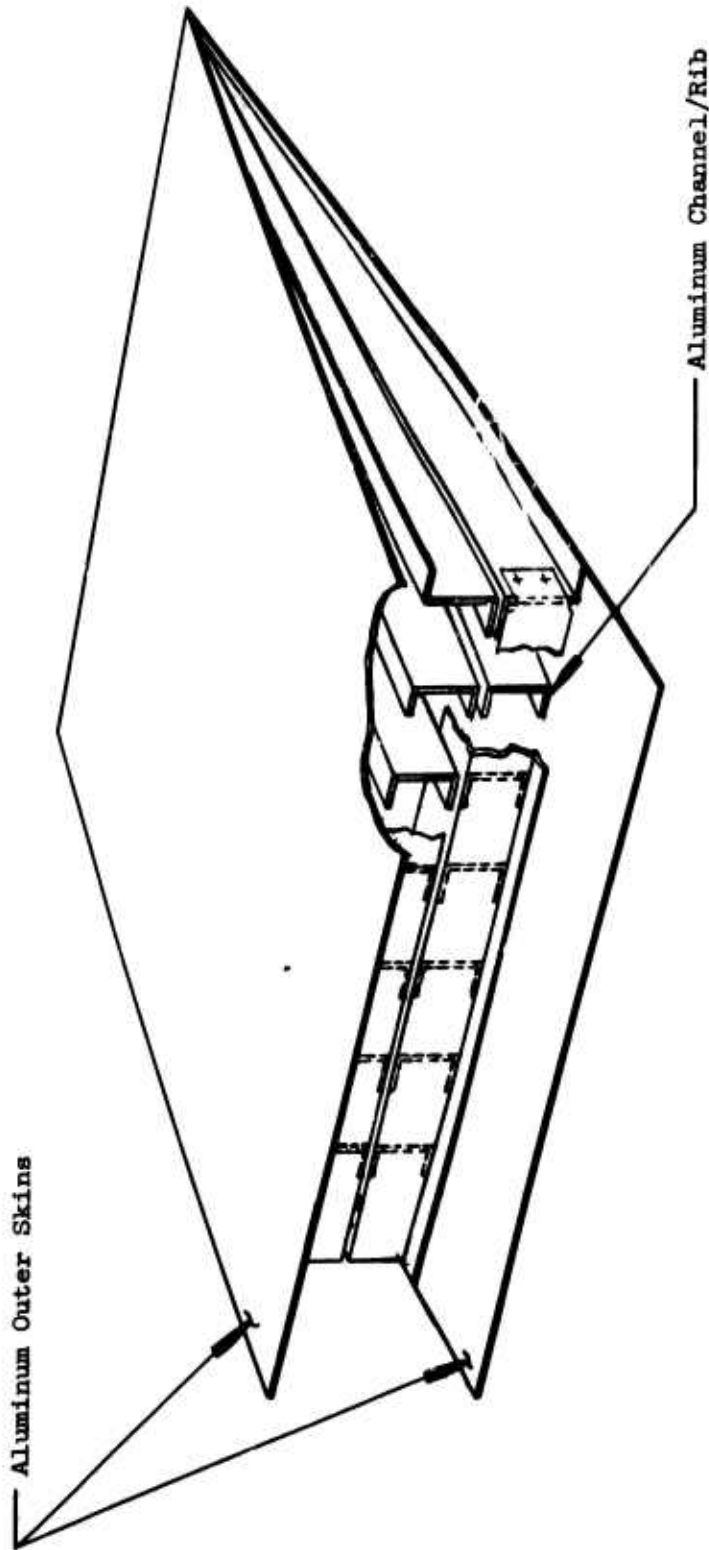

Figure 7. All-Aluminum Channel/Rib Design.

TABLE 1. POCKET ANALYSIS

| Design | Advantages | Disadvantages |
|---|--|---|
| EWR 38633 (Figures 1 and 2) | <ol style="list-style-type: none"> 1. Lightweight 2. Simple to assemble on blade 3. Structurally sound 4. Maintains close contour | <ol style="list-style-type: none"> 1. Requires backwall spacers |
| Universal Pocket (Figure 3) | <ol style="list-style-type: none"> 1. Structurally sound 2. Maintains close contour | <ol style="list-style-type: none"> 1. Requires backwall spacers 2. Requires inboard side shims 3. Reduces number of inboard pockets replaceable in a blade 4. Difficult to assemble |
| Aluminum Skins/Solid Honeycomb Core (Figure 4) | Note: This design was fabricated just to show scissors concept and to demonstrate feasibility of assembly on any position on the spar. | |
| Aluminum Skins/Honeycomb Core Rib (Figure 5) | <ol style="list-style-type: none"> 1. Simple to assemble on blade 2. Requires no side shims 3. Maintains close contour | <ol style="list-style-type: none"> 1. Needs structural reinforcement 2. Honeycomb exposed to elements 3. Heavier than EWR 38633 4. Requires backwall spacers |
| Fiberglass Skins/Honeycomb Core (Figure 6) | <ol style="list-style-type: none"> 1. Simple to assemble on blade 2. Requires no side shims 3. Maintains close contour 4. Structurally sound | <ol style="list-style-type: none"> 1. Heavier than EWR 38633 2. Requires backwall spacer |
| All-Aluminum Channel/Rib (Figure 7) | <ol style="list-style-type: none"> 1. Lightweight 2. Simple to assemble on blade 3. Maintains close contour 4. Requires no side shims | <ol style="list-style-type: none"> 1. Unsupported ribs makes structure unstable 2. Requires backwall spacers |

BACKWALL SPACERS

In addition to eliminating the side shims to simplify replaceable pocket installation, efforts were also made to eliminate the backwall spacers by simply moving the pocket up against the back of the spar. This would provide a blade with a $\frac{1}{4}$ -in. shorter chord in the areas of the #2, #3 and #4 pockets and a $\frac{1}{8}$ -in. shorter chord for pockets #5 through #8. Aerodynamic analysis was performed to determine changes in performance, if any. It was concluded that there would be negligible effect in lift, out-of-track and pitching moment due to chord shortening. However, it was decided to reject this idea because it did not eliminate the requirement for half backwall spacers at pockets #5 and #9. In addition, the bonding fixture was designed for multiple pocket replacement, which requires that the pockets line up at the trailing edge. Lastly, there was the possibility that having a pocket that did not line up with adjacent pockets during installation might tend to confuse the installer more than having a backwall spacer.

Another way to eliminate backwall spacers was to design the front of the replaceable pocket with an adjustable plate which could be moved forward and backward to compensate for the $\frac{1}{8}$ -in. and $\frac{1}{4}$ -in. differences on the spar backwall. This concept required an adjusting mechanism with screws; it resulted in a complicated and heavy solution and consequently was discarded. Based on the above investigations, it was decided that the backwall spacer was the most practical approach at this time.

The backwall spacers designed for the EWR 38633 field-replaceable pocket are shown in Figures 8 and 9. They consist of a .012-in.-thick aluminum strip that extends the spanwise length of a pocket. The side of the spacer that adjoins the pocket has bonded-on phenolic strips to provide the $\frac{1}{8}$ -in. and $\frac{1}{4}$ -in. space required to align the pocket requiring a spacer with the blade trailing edge. The phenolic strips are bonded to the aluminum with EA 9320, the field kit proposed adhesive. The spacer is provided with a flange as shown on Figure 9. The flange on the aluminum strip serves two purposes. Primarily, it supports the pocket skins at the spar back corner. It removes the unsupported area that occurs when the pocket is moved back either $\frac{1}{8}$ - in. or $\frac{1}{4}$ -in. away from the spar. The added support feasibly increases the life of the pocket in fatigue. Secondly, the flange virtually eliminates any possibility of the spacer being installed backwards and it becomes obvious to any installer that the spacer must be placed with the flange over the spar.

Figure 8 shows the $\frac{1}{8}$ -in. spacer; the $\frac{1}{4}$ -in. spacer is identical except that it has thicker phenolic blocks. The field kit would contain one each of the above spacers. Although not shown, perforations would be provided at the center of the aluminum strip to allow for separation in the event half spacer is required. These two spacers should suffice for any combination of backwall spacers required for repair.

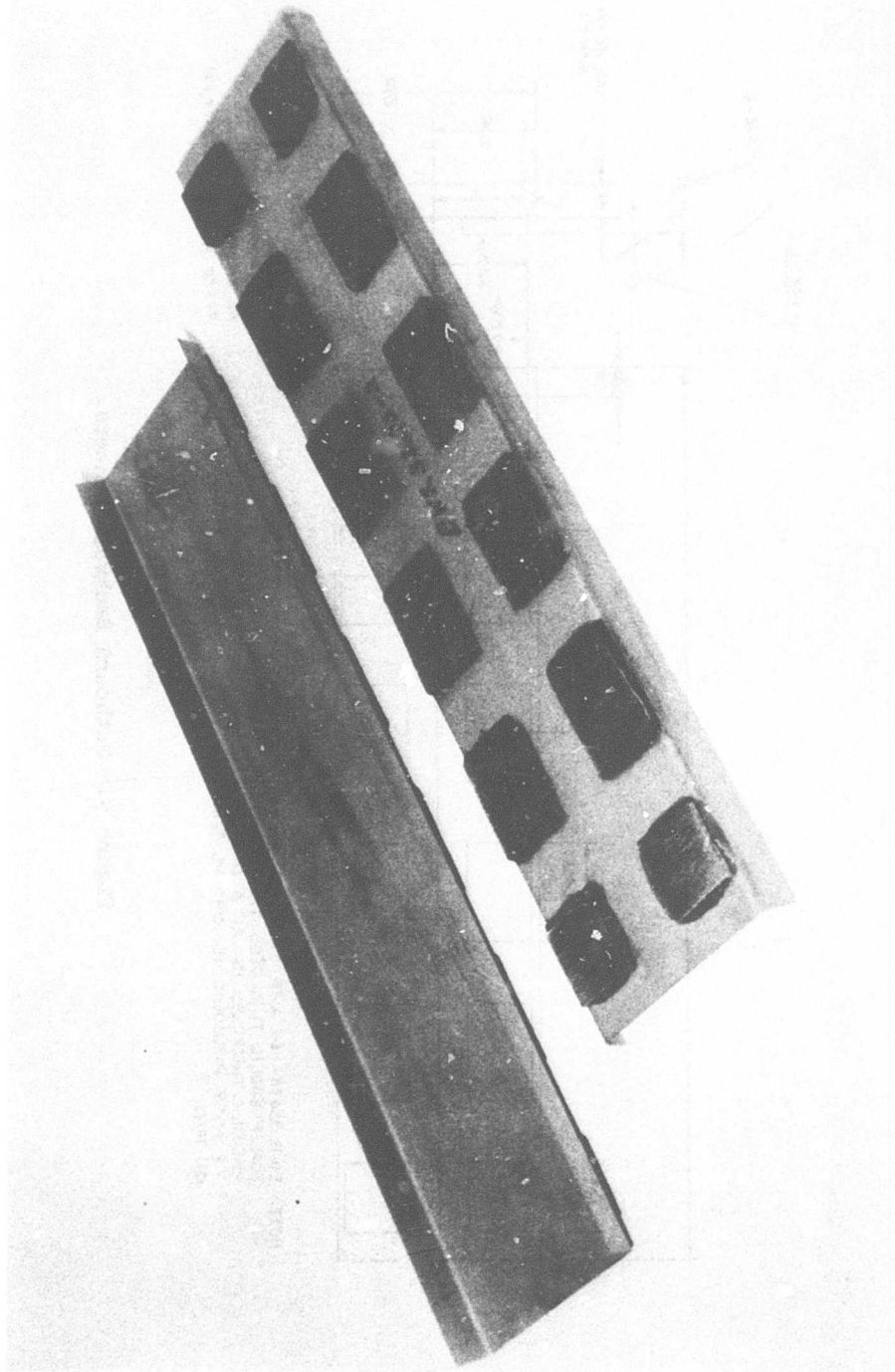

Figure 8. Backwall Spacer.

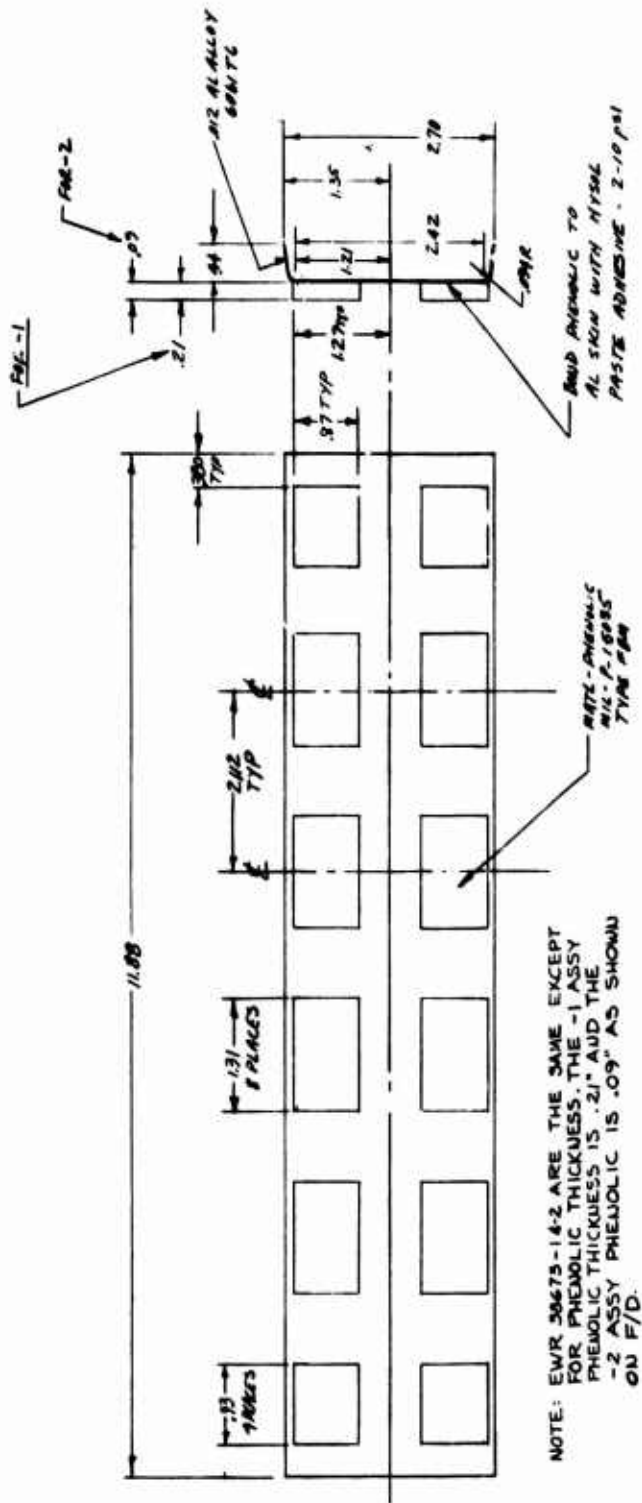

Figure 9. Outboard Backwall Spacers.

ANALYSIS

The structural analysis of EWR 38633 field-replaceable pocket consisted of weight estimation, location of pocket center of gravity, crippling of the pocket skin at the spar backwall, bending of the -106 and -107 stringers and skin panel flutter. The critical analysis was estimating the differences in weight and center of gravity between the replaceable and production pockets to arrive at deltas in spanwise, chordwise and pitching moments and blade track. Sufficient analysis was performed to indicate that the pocket was structurally sound. Static and dynamic tests conducted later corroborated the analysis.

The analysis for aerodynamic effects due to pocket contour variation was established in Reference 1. It was shown that small differences in airfoil contour between the universal and production pockets resulted in negligible effects in aerodynamic performance. EWR 38633 Revisions C and D field-replaceable pockets installed on CH-54B blades at Sikorsky and in the field had similar small differences in contour (.010 to .020 inch). Consequently, it was considered that there would be no noticeable differences in aerodynamics, and it was later borne out by flight test.

POCKET FABRICATION

One-hundred EWR 38633 field-replaceable pockets were fabricated. The first 71 pockets were fabricated to EWR 38633 Revision C, Figure 2, a two-piece outer skin. Because of the possibility of bond separation when tabbing of pockets was required to trim a blade and also to simplify and obtain a better structure, the last 29 pockets were fabricated with one-piece outer skins, EWR 38633 Revision D. Five of the new pockets were utilized for tool and bond tryout and proof load tests. The remaining 24 pockets were packaged in kits for field service evaluation: 10 pockets each were installed on blades at Fort Eustis, Virginia, and Fort Wainwright, Alaska. The other 4 pocket kits will serve as spares, 2 each for Fort Eustis and Fort Wainwright.

The total distribution of pockets fabricated for Revision C was: 4 pockets for tool and bond tryout, 20 pockets for proof load tests, 30 pockets for fatigue tests, and 17 pockets for whirl and flight test at Sikorsky Aircraft. The pockets fabricated to Revision D were: 3 pockets for tool and bond tryout, 2 pockets for proof load tests, and 24 pockets for field flight test evaluation.

BONDING FIXTURE TOOLING

The bonding fixture tool (Figure 10) designed for the field-replaceable pocket is the same in principle as the 6405-15011 bonding fixture. The bungee cord concept to obtain pressure has been retained because it is a practical and an economical approach and can be easily installed over a pocket repair. The bonding fixture of Figure 10 has been simplified by reducing the side aluminum bars to two pieces. The original bonding fixture had six aluminum bars because of the requirement for bonding the pocket skins to the ribs and side shims. With the new design, without the

requirement for side shims, pressure is required only at the spar side walls, therefore, aluminum bars are required only at the spar side walls.

The tool has also been improved by making provisions for multiple pocket bonding. This has been accomplished by adding projecting angles on one side of the front bar -043 Bar Assy and a projecting channel on one side of -044 Channel Assy. The two projections allow for two or more bonding fixtures to be interlocked to provide for multiple pocket repair.

It was noted during installation of pockets in the field that additional refinements could be made to the tool to enhance pocket-to-spar bonding; these are discussed under conclusions.

| ITEM NO. | PART NO. | USED ON MODEL | FIELD LABELS | | EFFECTIVITY | | REPLACED BY | | | | | | | | | | | | | | | | | | | |
|---|----------|---------------|--|------|-------------|--|-------------|--------|--|--|--|--|--|--|--|--|--|--|--|--|--|--|--|--|--|--|
| | | | FROM | THRU | FROM | THRU | PART NO. | REASON | | | | | | | | | | | | | | | | | | |
| 1. P/F N/A 2. P/F TNS 6 | | | | | | | | | | | | | | | | | | | | | | | | | | |
| [Large grid area for assembly details] | | | | | | | | | | | | | | | | | | | | | | | | | | |
| <table border="1" style="width: 100%; border-collapse: collapse;"> <tr> <td style="width: 25%;"></td> <td style="width: 25%;"></td> <td style="width: 25%;"></td> <td style="width: 25%;"></td> <td style="width: 25%;"></td> <td style="width: 25%;"></td> <td style="width: 25%;"></td> <td style="width: 25%;"></td> <td style="width: 25%;"></td> </tr> <tr> <td colspan="3"></td> <td colspan="3"> 20 - EMERGENCY STANDARD OR SPEC 20R - EMERGENCY CHANGE REPORT 20S - EMERGENCY CHANGE 20T - REQUEST TO CHANGE 20U - EMERGENCY CHANGE SPEC </td> <td colspan="3"> 21 - EMERGENCY STANDARD OR SPEC 21R - EMERGENCY CHANGE REPORT 21S - EMERGENCY CHANGE 21T - REQUEST TO CHANGE 21U - EMERGENCY CHANGE SPEC </td> </tr> </table> | | | | | | | | | | | | | | | | | | | | | 20 - EMERGENCY STANDARD OR SPEC 20R - EMERGENCY CHANGE REPORT 20S - EMERGENCY CHANGE 20T - REQUEST TO CHANGE 20U - EMERGENCY CHANGE SPEC | | | 21 - EMERGENCY STANDARD OR SPEC 21R - EMERGENCY CHANGE REPORT 21S - EMERGENCY CHANGE 21T - REQUEST TO CHANGE 21U - EMERGENCY CHANGE SPEC | | |
| | | | | | | | | | | | | | | | | | | | | | | | | | | |
| | | | 20 - EMERGENCY STANDARD OR SPEC 20R - EMERGENCY CHANGE REPORT 20S - EMERGENCY CHANGE 20T - REQUEST TO CHANGE 20U - EMERGENCY CHANGE SPEC | | | 21 - EMERGENCY STANDARD OR SPEC 21R - EMERGENCY CHANGE REPORT 21S - EMERGENCY CHANGE 21T - REQUEST TO CHANGE 21U - EMERGENCY CHANGE SPEC | | | | | | | | | | | | | | | | | | | | |

Figure 10. Bonding Fixture Assembly

A

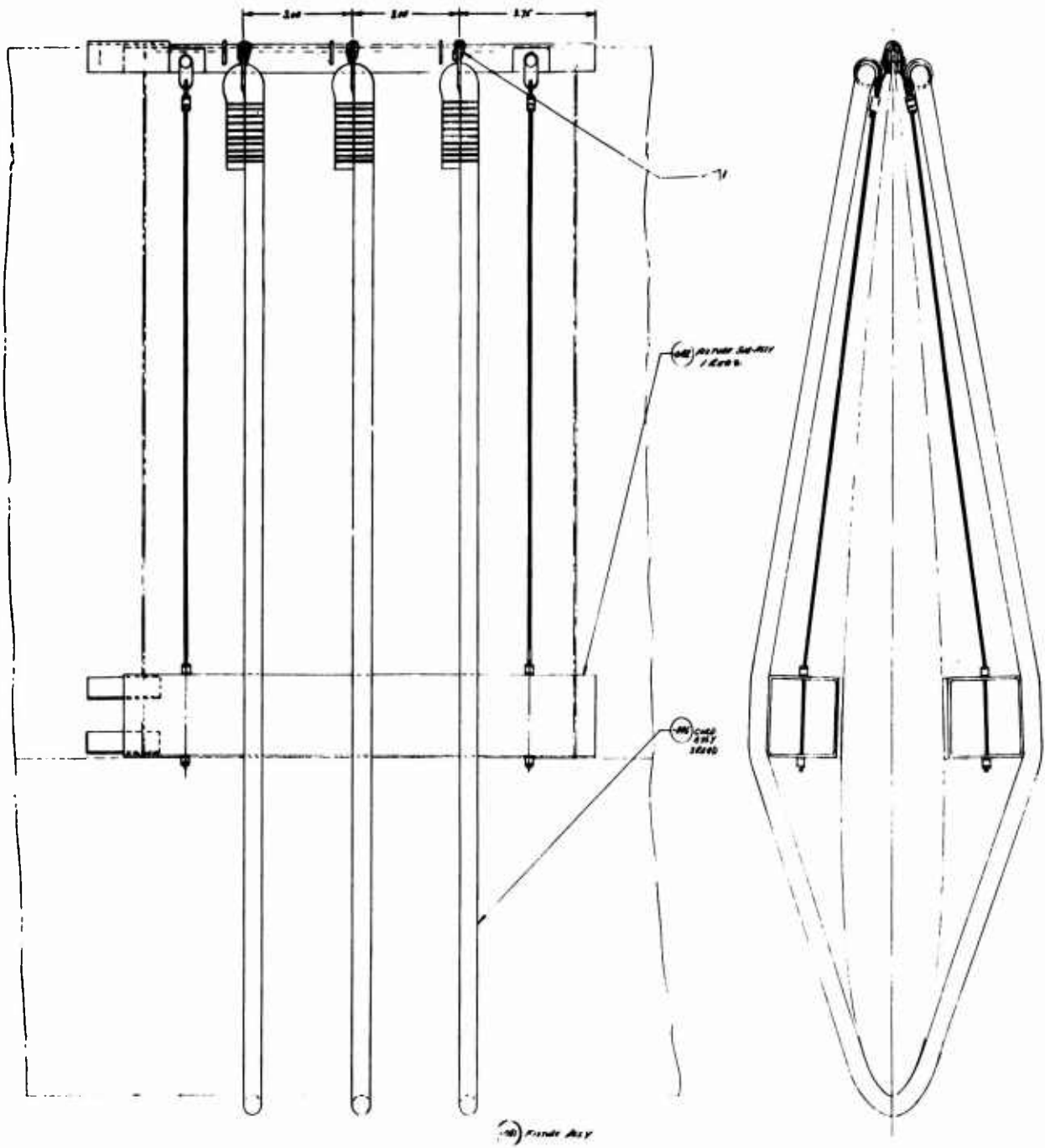

| REVISIONS | | APPROVED | |
|-----------|------|----------|-----|
| NO. | DATE | BY | FOR |
| 1 | | | |
| 2 | | | |
| 3 | | | |
| 4 | | | |
| 5 | | | |
| 6 | | | |
| 7 | | | |
| 8 | | | |
| 9 | | | |
| 10 | | | |

| REVISIONS | | APPROVED | |
|-----------|------|----------|-----|
| NO. | DATE | BY | FOR |
| 1 | | | |
| 2 | | | |
| 3 | | | |
| 4 | | | |
| 5 | | | |
| 6 | | | |
| 7 | | | |
| 8 | | | |
| 9 | | | |
| 10 | | | |

Figure 10. Continued.

4

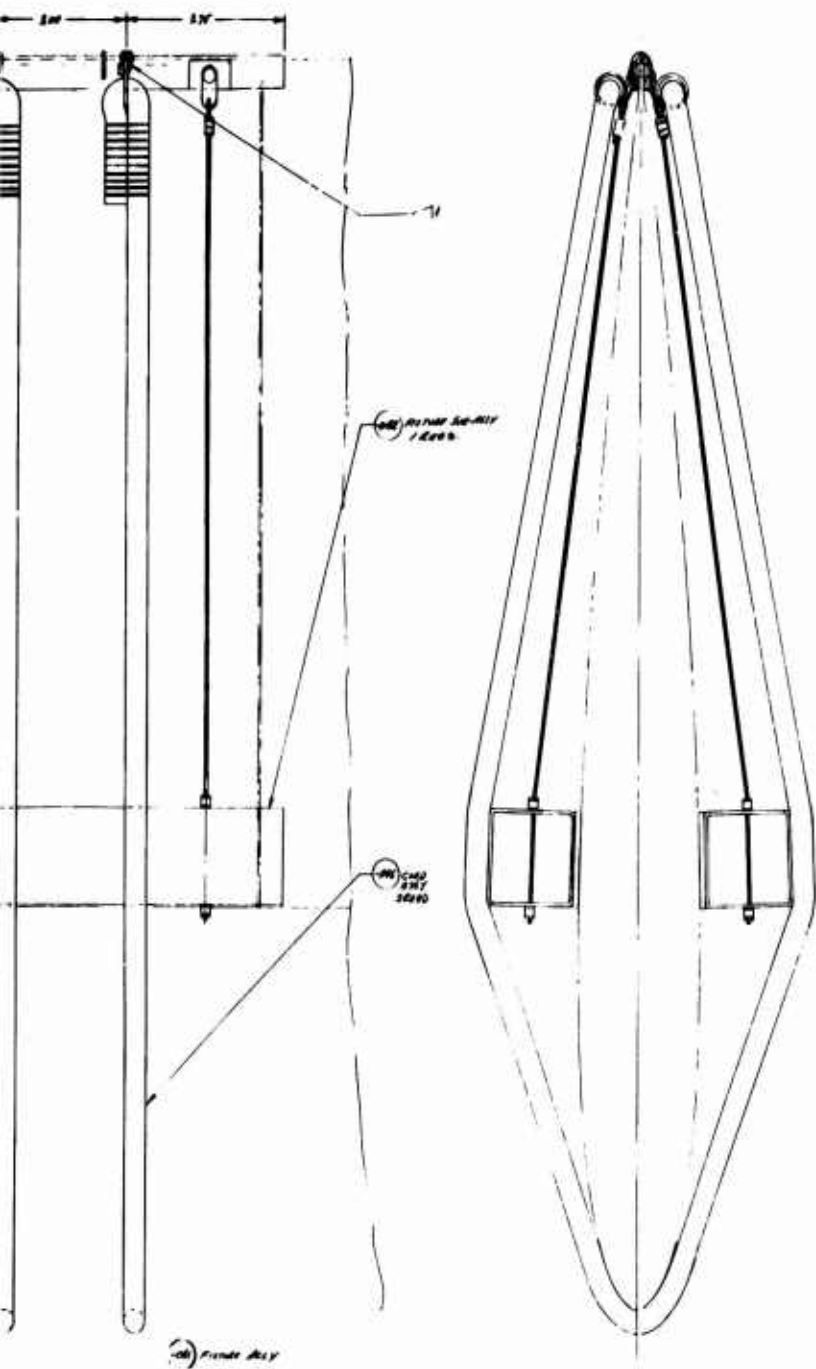

1. BOND CLIP AT ONE END OF -045 CABLE ASSEMBLY TO -046 CHANNEL ASSEMBLY WITH RC 1261 OR EQUIV. WITH 21-0619.

| REV | DESCRIPTION | DATE |
|-----|-------------|------|
| 1 | ASSEMBLY | |
| 2 | REVISION | |
| 3 | REVISION | |
| 4 | REVISION | |
| 5 | REVISION | |
| 6 | REVISION | |
| 7 | REVISION | |
| 8 | REVISION | |
| 9 | REVISION | |
| 10 | REVISION | |

| | |
|--|--|
| | |
| | |
| | |
| | |
| | |
| | |
| | |
| | |
| | |
| | |

| REV | DESCRIPTION | DATE |
|-----|-------------|------|
| 1 | ASSEMBLY | |
| 2 | REVISION | |
| 3 | REVISION | |
| 4 | REVISION | |
| 5 | REVISION | |
| 6 | REVISION | |
| 7 | REVISION | |
| 8 | REVISION | |
| 9 | REVISION | |
| 10 | REVISION | |

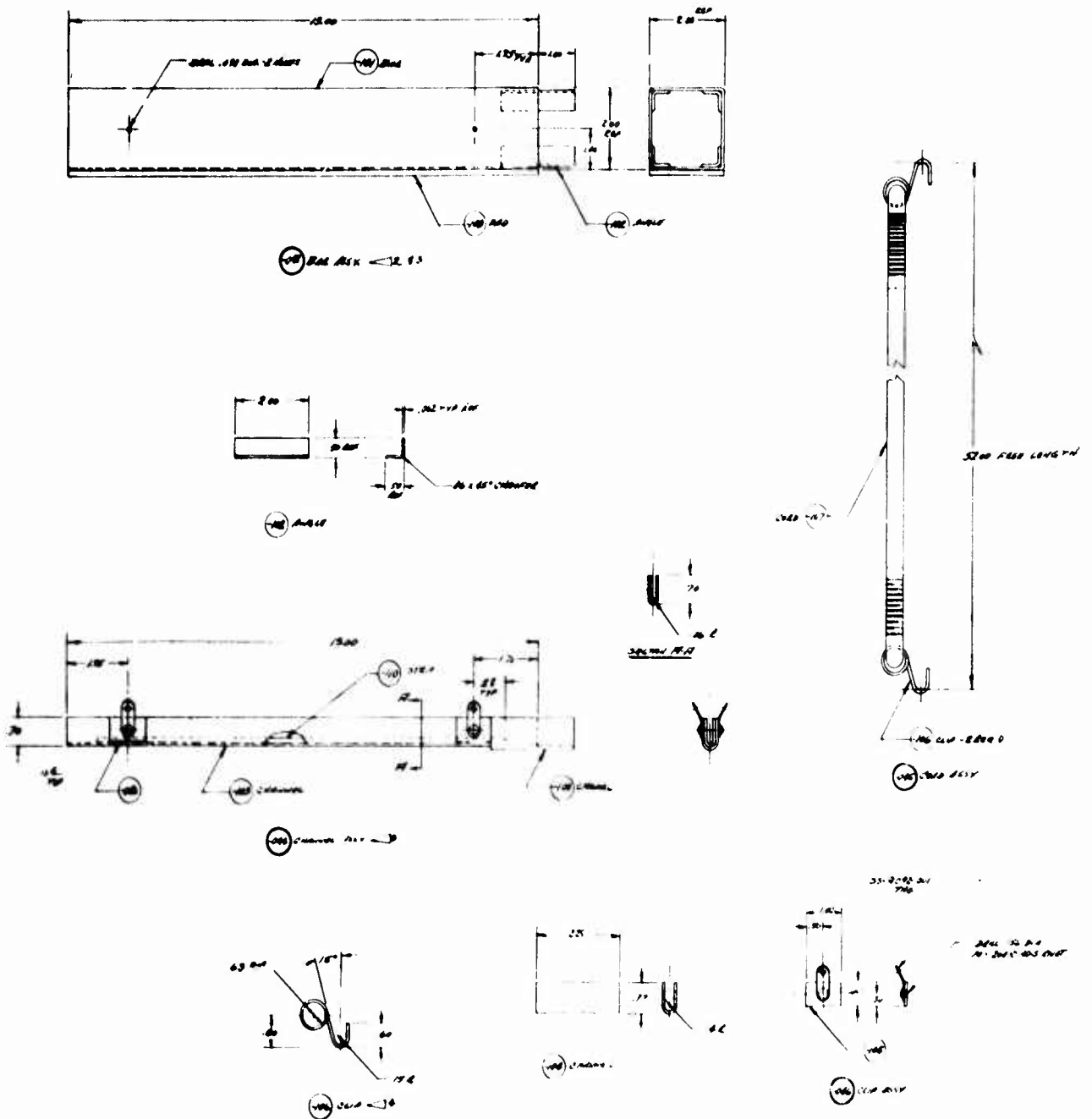
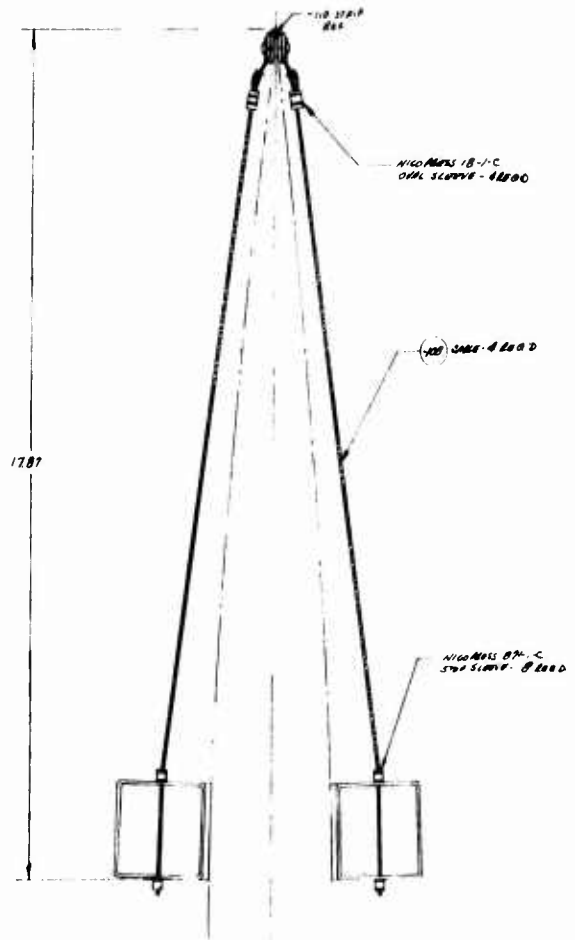
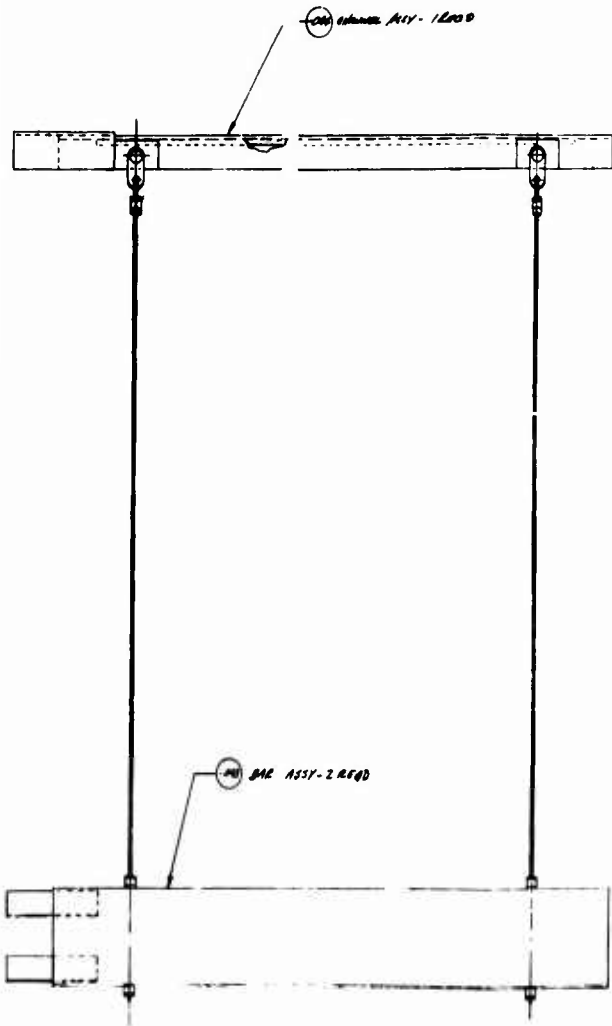

Figure 10. Continued.



100 FITTING SUB-157

| REVISIONS | | APPROVALS | |
|-----------|------------------------|-----------|----------|
| NO. | DESCRIPTION | DATE | INITIALS |
| 1 | ISSUED FOR FABRICATION | | |
| 2 | REVISION | | |
| 3 | REVISION | | |
| 4 | REVISION | | |
| 5 | REVISION | | |
| 6 | REVISION | | |
| 7 | REVISION | | |
| 8 | REVISION | | |
| 9 | REVISION | | |
| 10 | REVISION | | |
| 11 | REVISION | | |
| 12 | REVISION | | |
| 13 | REVISION | | |
| 14 | REVISION | | |
| 15 | REVISION | | |
| 16 | REVISION | | |
| 17 | REVISION | | |
| 18 | REVISION | | |
| 19 | REVISION | | |
| 20 | REVISION | | |
| 21 | REVISION | | |
| 22 | REVISION | | |
| 23 | REVISION | | |
| 24 | REVISION | | |
| 25 | REVISION | | |
| 26 | REVISION | | |
| 27 | REVISION | | |
| 28 | REVISION | | |
| 29 | REVISION | | |
| 30 | REVISION | | |
| 31 | REVISION | | |
| 32 | REVISION | | |
| 33 | REVISION | | |
| 34 | REVISION | | |
| 35 | REVISION | | |
| 36 | REVISION | | |
| 37 | REVISION | | |
| 38 | REVISION | | |
| 39 | REVISION | | |
| 40 | REVISION | | |
| 41 | REVISION | | |
| 42 | REVISION | | |
| 43 | REVISION | | |
| 44 | REVISION | | |
| 45 | REVISION | | |
| 46 | REVISION | | |
| 47 | REVISION | | |
| 48 | REVISION | | |
| 49 | REVISION | | |
| 50 | REVISION | | |

6870-10152

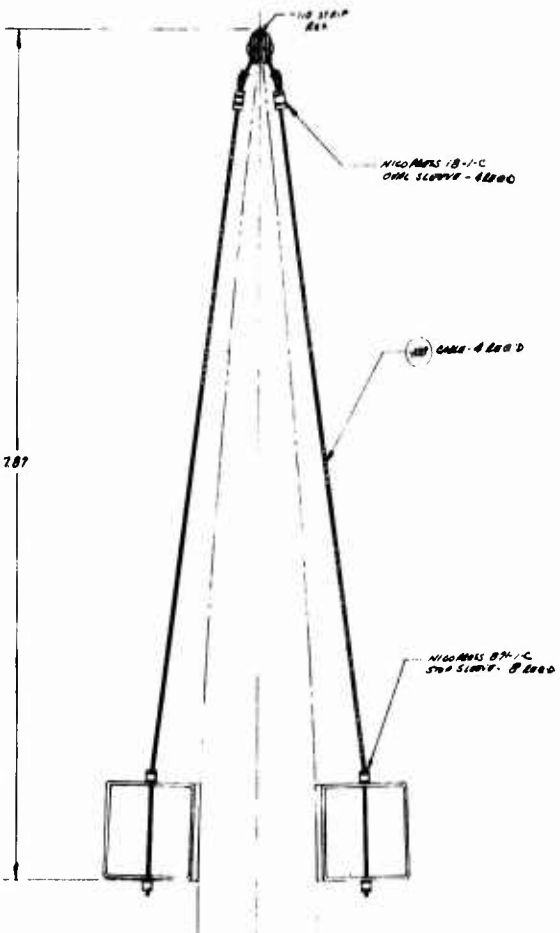

- 1- REMOVE ALL EXCESS BAGS. ONE - ONE E.
- 2- BOND 110 PAD TO 111 BAG WITH AN RTV ADHESIVE IN ACCORDANCE WITH 750600.
- 3- BOND 110 BAG TO 111 BAG & 112 BAG TO 113 BAG CHANNEL WITH AN RTV ADHESIVE IN ACCORDANCE WITH 750600.
- 4- AFTER PACKING, MUST TEST 110 CLIP TO 111 BAG WITH A 111 BAG WITH AN RTV ADHESIVE IN ACCORDANCE WITH 750600.
- 5- EXTENDED STRIP SHALL BE PURCHASED WITH TRIMMING AND 111-11-6000.
- 6- BOND 110 STRIP TO 113 CHANNEL WITH AN RTV ADHESIVE IN ACCORDANCE WITH 750600.

287

| REVISIONS | |
|-----------|-----------------------|
| NO. | DESCRIPTION |
| 1 | ISSUED FOR PRODUCTION |
| 2 | REVISIONS |
| 3 | REVISIONS |
| 4 | REVISIONS |
| 5 | REVISIONS |
| 6 | REVISIONS |
| 7 | REVISIONS |
| 8 | REVISIONS |
| 9 | REVISIONS |
| 10 | REVISIONS |

| | | | | | |
|-----|-----------|---------|---------|---------|---------|
| 110 | 110 STRIP | 110 BAG | 111 BAG | 112 BAG | 113 BAG |
| 114 | 114 BAG | 115 BAG | 116 BAG | 117 BAG | 118 BAG |
| 119 | 119 BAG | 120 BAG | 121 BAG | 122 BAG | 123 BAG |
| 124 | 124 BAG | 125 BAG | 126 BAG | 127 BAG | 128 BAG |
| 129 | 129 BAG | 130 BAG | 131 BAG | 132 BAG | 133 BAG |
| 134 | 134 BAG | 135 BAG | 136 BAG | 137 BAG | 138 BAG |
| 139 | 139 BAG | 140 BAG | 141 BAG | 142 BAG | 143 BAG |
| 144 | 144 BAG | 145 BAG | 146 BAG | 147 BAG | 148 BAG |
| 149 | 149 BAG | 150 BAG | 151 BAG | 152 BAG | 153 BAG |
| 154 | 154 BAG | 155 BAG | 156 BAG | 157 BAG | 158 BAG |
| 159 | 159 BAG | 160 BAG | 161 BAG | 162 BAG | 163 BAG |
| 164 | 164 BAG | 165 BAG | 166 BAG | 167 BAG | 168 BAG |
| 169 | 169 BAG | 170 BAG | 171 BAG | 172 BAG | 173 BAG |
| 174 | 174 BAG | 175 BAG | 176 BAG | 177 BAG | 178 BAG |
| 179 | 179 BAG | 180 BAG | 181 BAG | 182 BAG | 183 BAG |
| 184 | 184 BAG | 185 BAG | 186 BAG | 187 BAG | 188 BAG |
| 189 | 189 BAG | 190 BAG | 191 BAG | 192 BAG | 193 BAG |
| 194 | 194 BAG | 195 BAG | 196 BAG | 197 BAG | 198 BAG |
| 199 | 199 BAG | 200 BAG | 201 BAG | 202 BAG | 203 BAG |
| 204 | 204 BAG | 205 BAG | 206 BAG | 207 BAG | 208 BAG |
| 209 | 209 BAG | 210 BAG | 211 BAG | 212 BAG | 213 BAG |
| 214 | 214 BAG | 215 BAG | 216 BAG | 217 BAG | 218 BAG |
| 219 | 219 BAG | 220 BAG | 221 BAG | 222 BAG | 223 BAG |
| 224 | 224 BAG | 225 BAG | 226 BAG | 227 BAG | 228 BAG |
| 229 | 229 BAG | 230 BAG | 231 BAG | 232 BAG | 233 BAG |
| 234 | 234 BAG | 235 BAG | 236 BAG | 237 BAG | 238 BAG |
| 239 | 239 BAG | 240 BAG | 241 BAG | 242 BAG | 243 BAG |
| 244 | 244 BAG | 245 BAG | 246 BAG | 247 BAG | 248 BAG |
| 249 | 249 BAG | 250 BAG | 251 BAG | 252 BAG | 253 BAG |
| 254 | 254 BAG | 255 BAG | 256 BAG | 257 BAG | 258 BAG |
| 259 | 259 BAG | 260 BAG | 261 BAG | 262 BAG | 263 BAG |
| 264 | 264 BAG | 265 BAG | 266 BAG | 267 BAG | 268 BAG |
| 269 | 269 BAG | 270 BAG | 271 BAG | 272 BAG | 273 BAG |
| 274 | 274 BAG | 275 BAG | 276 BAG | 277 BAG | 278 BAG |
| 279 | 279 BAG | 280 BAG | 281 BAG | 282 BAG | 283 BAG |
| 284 | 284 BAG | 285 BAG | 286 BAG | 287 BAG | 288 BAG |
| 289 | 289 BAG | 290 BAG | 291 BAG | 292 BAG | 293 BAG |
| 294 | 294 BAG | 295 BAG | 296 BAG | 297 BAG | 298 BAG |
| 299 | 299 BAG | 300 BAG | 301 BAG | 302 BAG | 303 BAG |

1

B

ADHESIVE ENVIRONMENTAL QUALIFICATION TESTS

BACKGROUND

Several ambient temperature curing adhesive systems were investigated as candidates for field pocket-to-spar bonding under Reference 1. Hysol EA 9302.9 was selected out of two eventual adhesives subjected to environmental, proof load and fatigue tests. One of the tasks under this contract was to perform the same environmental qualifications tests to evaluate a new adhesive, Hysol's EA 9320, and to compare its shear and peel strength to the existing Hysol EA 9302.9. Another task was to estimate the time to cure the adhesive to obtain minimum acceptable shear and peel values.

Hysol EA 9320 was selected as the final adhesive based on the results of the following tests.

TEST PROCEDURE

To perform the tests, shear and peel specimens were fabricated per Figures 11 and 12. The aluminum panels were processed through the production chromic acid anodize line. This included degreasing, deoxidizing, and alkaline cleaning prior to anodizing. After anodizing, the panels were oven dried at 135°F and primed with nitrile-phenolic primer per production procedures.

The finished specimens were to represent a bond formed "in the field" when a replacement pocket is bonded to a blade spar that is still coated with residual adhesive. In production, nitrile-phenolic-primed skins and ribs were bonded together, at 350°F for 1 hour. Therefore, one-half of all the primed panels were subjected to a heat cure of 350°F to represent the pocket skin. The remaining half of the panels had the production nitrile-phenolic adhesive bonded to them at 350°F to represent the residual adhesive found on the spar when a damaged pocket is removed. The complete specimen was composed of one heat-cured primed panel and one adhesive-coated panel assembled with the candidate adhesive.

To prepare the panels for bonding, the residual adhesive was lightly sanded with #80 grit paper and given a methyl ethyl ketone (MEK) wipe to remove loose particles. The primed panels were given an MEK wipe immediately prior to assembly with the candidate adhesive. Pressure for bonding was 5 psi. The specimens were assembled under the following temperature and humidity conditions:

| | |
|-------------|------------------|
| Condition 1 | 100°F and 85% RH |
| Condition 2 | 75°F and 50% RH |
| Condition 3 | 40°F and 20% RH |

Prior to coating the panels with the candidate adhesive, the panels and fixtures were subjected to the required temperature/humidity condition until equilibrium was established. The panels were then coated with adhesive and assembled in the test fixtures (Figure 13). The length of time required for the candidate adhesive to produce a shear strength of 1000 psi

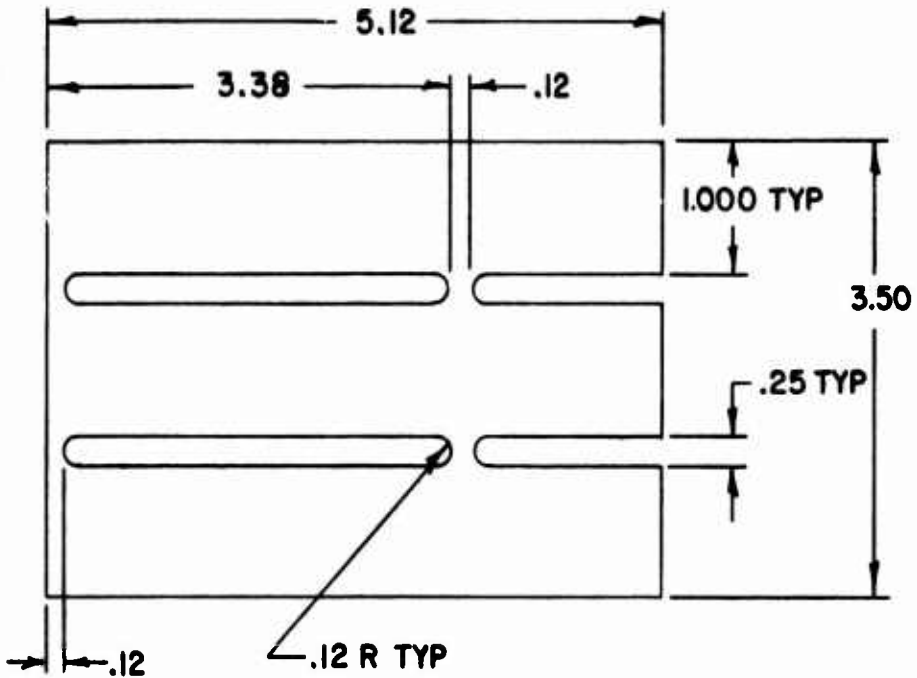

INDIVIDUAL PANEL

MATERIAL : QQ-A-250/5
 ALCLAD 2024-T3
 .064 THICK, NOMINAL

DIMENSIONS IN INCHES

TOLERANCES:

$\pm .03$ 2-PLACE DECIMAL
 $\pm .010$ 3-PLACE DECIMAL

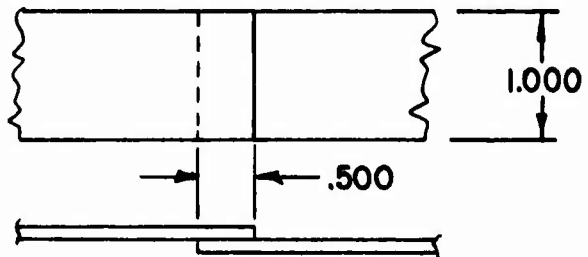
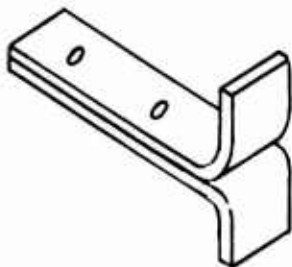
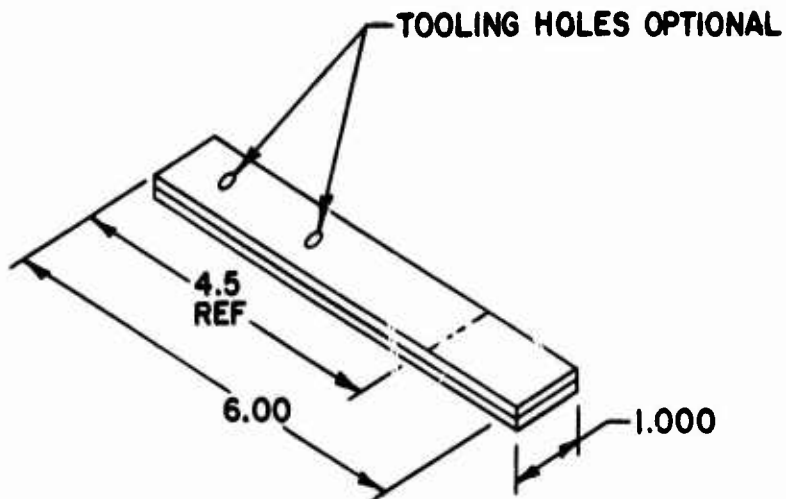

Figure 11. Overlap Shear Test Specimen.



**MATERIAL: QQ-A-250/11
AL. ALLOY 6061-T6
.020 THICK, NOMINAL**

DIMENSIONS IN INCHES

TOLERANCES:

± .03 2-PLACE DECIMAL

± .010 3-PLACE DECIMAL

Figure 12. "T" Peel Specimen.

and peel strength of 10 pounds per inch of width was established for each cure condition. The cure time required to reach minimum acceptable pocket bonding requirements is presented in Table 2. All specimens were tested at room temperature within 20 minutes of curing.

TEST CONDITIONS

A minimum of 108 peel and shear specimens of the candidate adhesive system were fabricated and tested at the following conditions:

54 Peel Tests for Each Adhesive

18 fabricated at +100°F and 85% RH
6 tested at -67°F
6 tested at Room Temperature + 75°
6 tested at 180°F

18 fabricated at +75°F and 50% RH
6 tested at -67°F
6 tested at Room Temperature +75°
6 tested at 180°F

18 fabricated at +40°F and 20% RH
6 tested at -67°F
6 tested at Room Temperature +75°
6 tested at +180°F

54 Shear Tests for Each Adhesive

18 fabricated at +100°F and 85% RH
6 tested at -67°F
6 tested at Room Temperature +75°
6 tested at +180°F

18 fabricated at +75°F and 50% RH
6 tested at -67°F
6 tested at Room Temperature +75°
6 tested at +180°F

18 fabricated at +40°F and 20% RH
6 tested at -67°F
6 tested at Room Temperature +75°
6 tested at +180°F

TEST EQUIPMENT

A Conrad Missimer environmental test chamber was positioned between the tension grips of a Riehle testing machine with the grips extending inside the test chamber. A test specimen was installed in the tension grips, the test chamber was brought to the required test temperature, and the specimen was allowed to soak at temperature for 3 minutes. The load was applied at

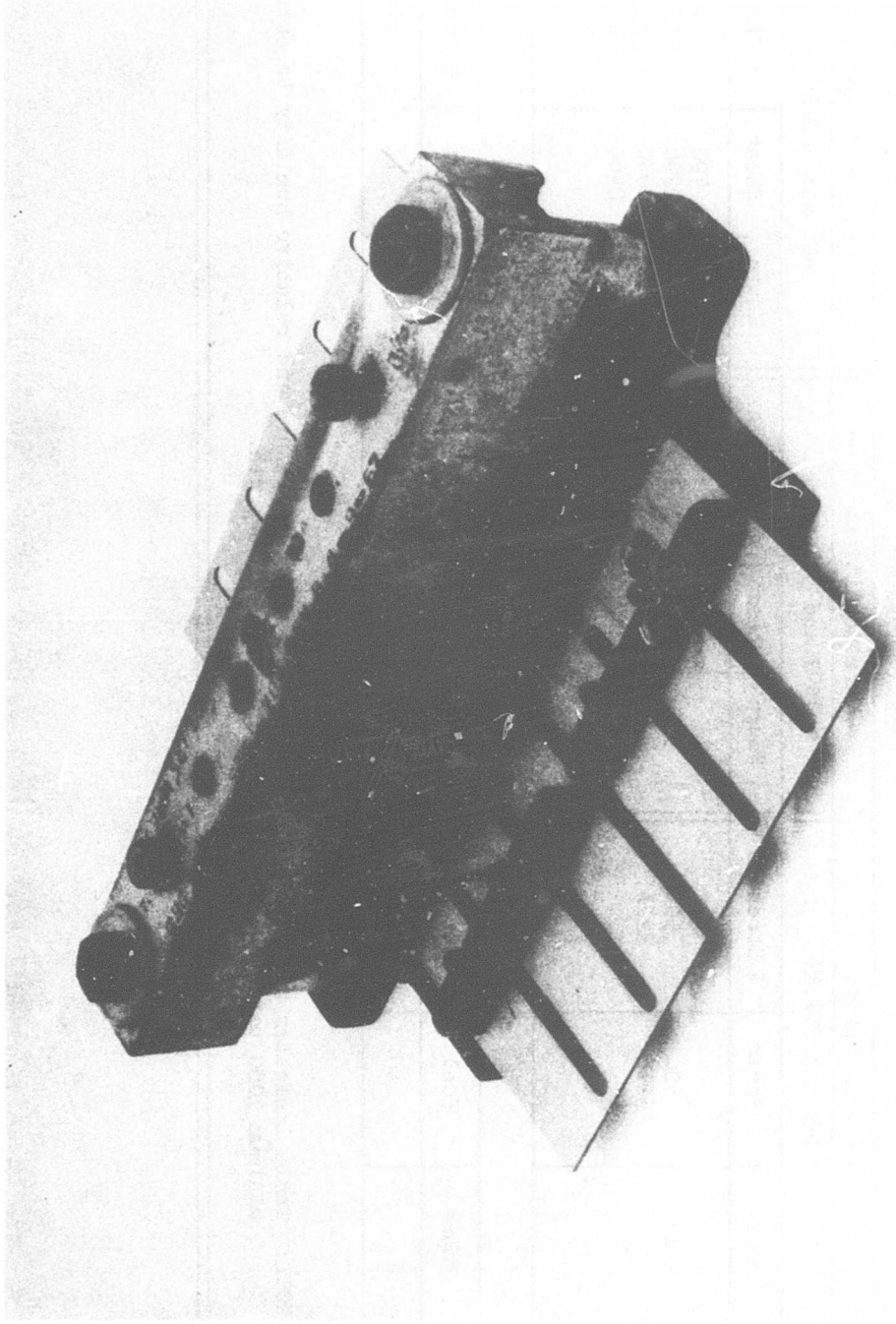

Figure 13. Shear Specimen Assembly Fixture.

TABLE 2. EA 9320 CURE TIME TO OBTAIN MINIMUM STRENGTHS

| SHEAR STRENGTH, PSI | | | | | | | | | |
|---|-------|------------|-----------------|-------|------------|-----------------|-------|------------|------------|
| Cure Conditions | | | Cure Conditions | | | Cure Conditions | | | |
| 100°F and 85% RH | | | 75°F and 50% RH | | | 40° and 20% RH | | | |
| Hours | Shear | % Strength | Hours | Shear | % Strength | Hours | Shear | % Strength | % Strength |
| 1 | | | 3 | | | 42 | | | |
| 1-1/2 | 600 | 60% | 3-1/2 | 270 | 27% | 45 | 790 | 79% | 79% |
| 2 | 3216 | 322% | 4 | 900 | 90% | 49 | 1290 | 129% | 129% |
| | | | 5 | 1426 | 142% | 53 | 1950 | 195% | 195% |
| | | | 8 | 2452 | 245% | | 2460 | 246% | 246% |
| | | | 24 | 3326 | 333% | | | | |
| PEEL STRENGTH, PIW (Pounds Per Inch of Width) | | | | | | | | | |
| Hours | Peel | % Strength | Hours | Peel | % Strength | Hours | Peel | % Strength | % Strength |
| 2 | 40 | 400% | 5 | 34.5 | 345% | 45 | 11 | 110% | 110% |

NOTE: Table indicates cure time required at specified temperature and relative humidity to obtain minimum 1000 psi shear strength and 10 lb peel strength.

the rate of 1,200 to 1,400 pounds per square inch per minute until failure for overlap shear specimens and a jaw separation rate of 3 inches per minute for peel specimens.

TEST RESULTS

The test results are presented in Table 3. All values are an average of a minimum of six specimens. The length of time that specimens were cured prior to testing varied with each cure condition and was established after the cure time required to reach minimum acceptable requirements was known. At 100°F specimens were cured for 2 hours, at 75°F they were cured between 16 and 20 hours, and at 40°F they were cured for 58-62 hours. In all cases the specimens were tested within 20 minutes of curing.

Specimens cured at 75°F and 40°F were not fully cured intentionally prior to testing, but were tested to obtain values that would represent pocket-to-spar bonds made, cured, and flown within the shortest possible time. Specimens fully cured at these temperatures would have higher values when tested at 75° and 180°F and would approach the test values shown when the adhesive was cured at 100°F.

On the shear and peel specimens tested at -67°F, the failure mode was the residual adhesive to the metal; this is the ultimate that can be expected at this test temperature. At +75°F and +180°F, the failure modes were cohesive in the candidate adhesive in that the candidate adhesive failed to the residual adhesive.

SELECTION OF HYSOL EA 9320

The values of EA 9320 appearing in Table 3 were replotted in Figures 14 and 15 to show peel and shear comparisons with the EA 9309.2 adhesive developed under Reference 1. Figure 14 indicates that the shear strength of EA 9309.2 is higher for some of the cure conditions. However, the peel strength of EA 9320 adhesive as shown in Figure 15 is considerably higher than EA 9309.2 for all environmental conditions tested.

A comparison was also made of minimum cure time to obtain acceptable pocket shear and peel bonds with both adhesives. Figure 16 shows that the EA 9320 adhesive requires approximately 15% less cure time than EA 9309.2 to obtain the 1000 psi minimum shear strength for both environmental conditions. The 10 pounds minimum peel cure time for EA 9320 at the 75°F and 50% RH condition is approximately one-half the time required for 9309.2; the adhesives require virtually the same cure time at 40% and 20% RH. It can also be seen from the plots that at 1000 psi minimum shear, the peel strength is 25 pounds (75°F and 59% RH) and 10 pounds (40° and 20% RH) at 4 hours and 43 hours respectively for the EA 9320 adhesive.

It is estimated that both adhesives would be suitable for field application. However, the much higher peel strength of the EA 9320 adhesive is a very desirable property because it is an indication of the adhesive toughness and should result in higher fatigue strength. This factor should override

TABLE 3. VALUES OBTAINED WITH HYSOL EA 9320 WHEN TESTED ON RESIDUAL MATERIAL

| Cure Conditions Test Conditions | Shear PSI | | | | Peel PIW (Pounds Per Inch of Width) | | | |
|------------------------------------|-----------|-----------------|----------------|----------------|-------------------------------------|-----------------|----------------|----------------|
| | Min. Req. | 100°F 85% RH | 75°F 50% RH | 40°F 20% RH | Min. Req. | 100°F 85% RH | 75°F 50% RH | 40°F 20% RH |
| -67°F | 1000 | 2726 | 2430* | 2657* | 6 | 31.6 | 32.0 | 35.8 |
| +75°F | 1000 | 3216 | 2650* | 2386* | 10 | 40 | 48 | 40 |
| +180°F | 1000 | 1355 | 512* | 535* | 6 | 26.3 | 37 | 25 |

*Not fully cured adhesive; see text.

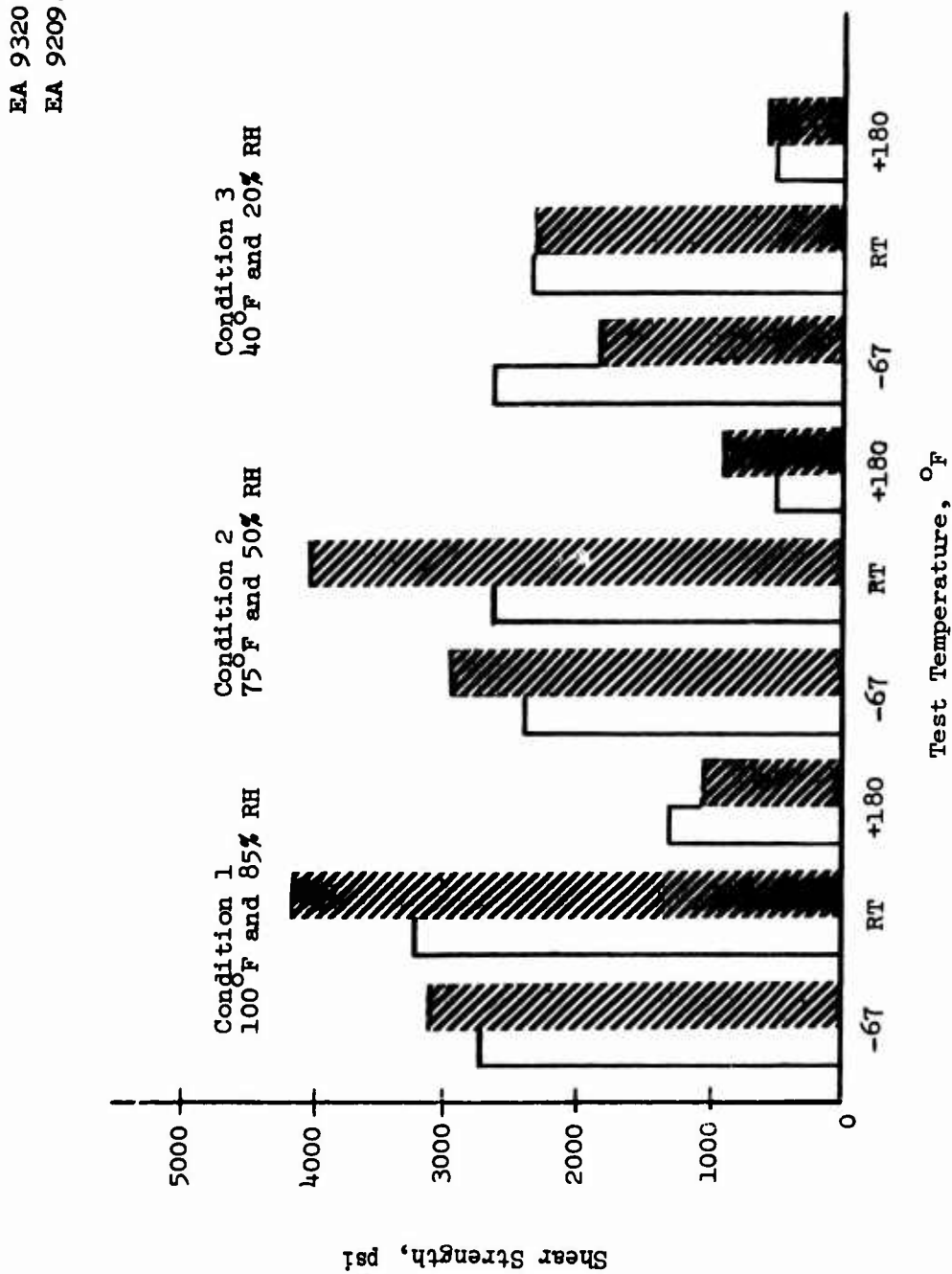

Figure 14. Comparison of EA 9320 and 9309.2 Shear Strength.



EA 9320

EA 9309.2

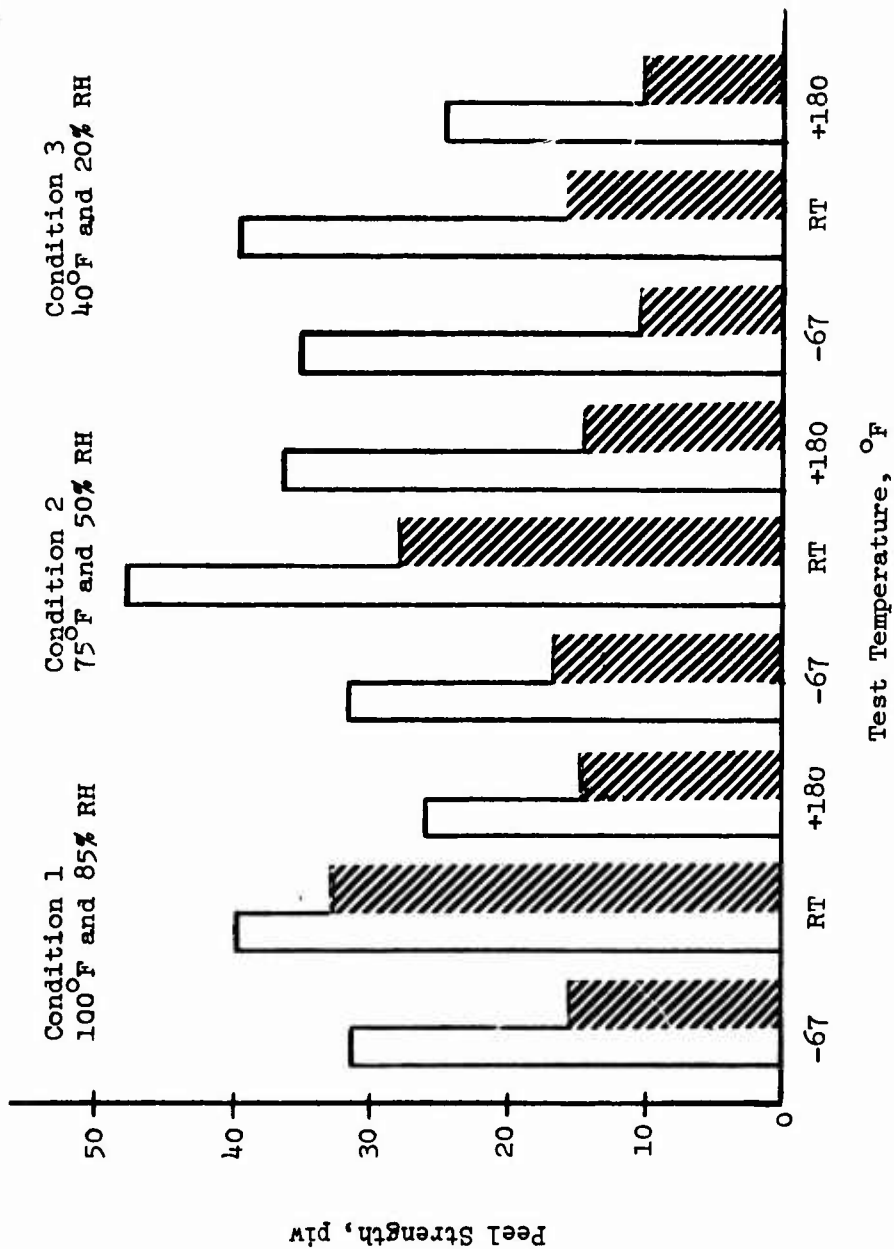

Figure 15. Comparison of EA 9320 and 9309.2 Peel Strength.

EA 9320
EA 9309.2

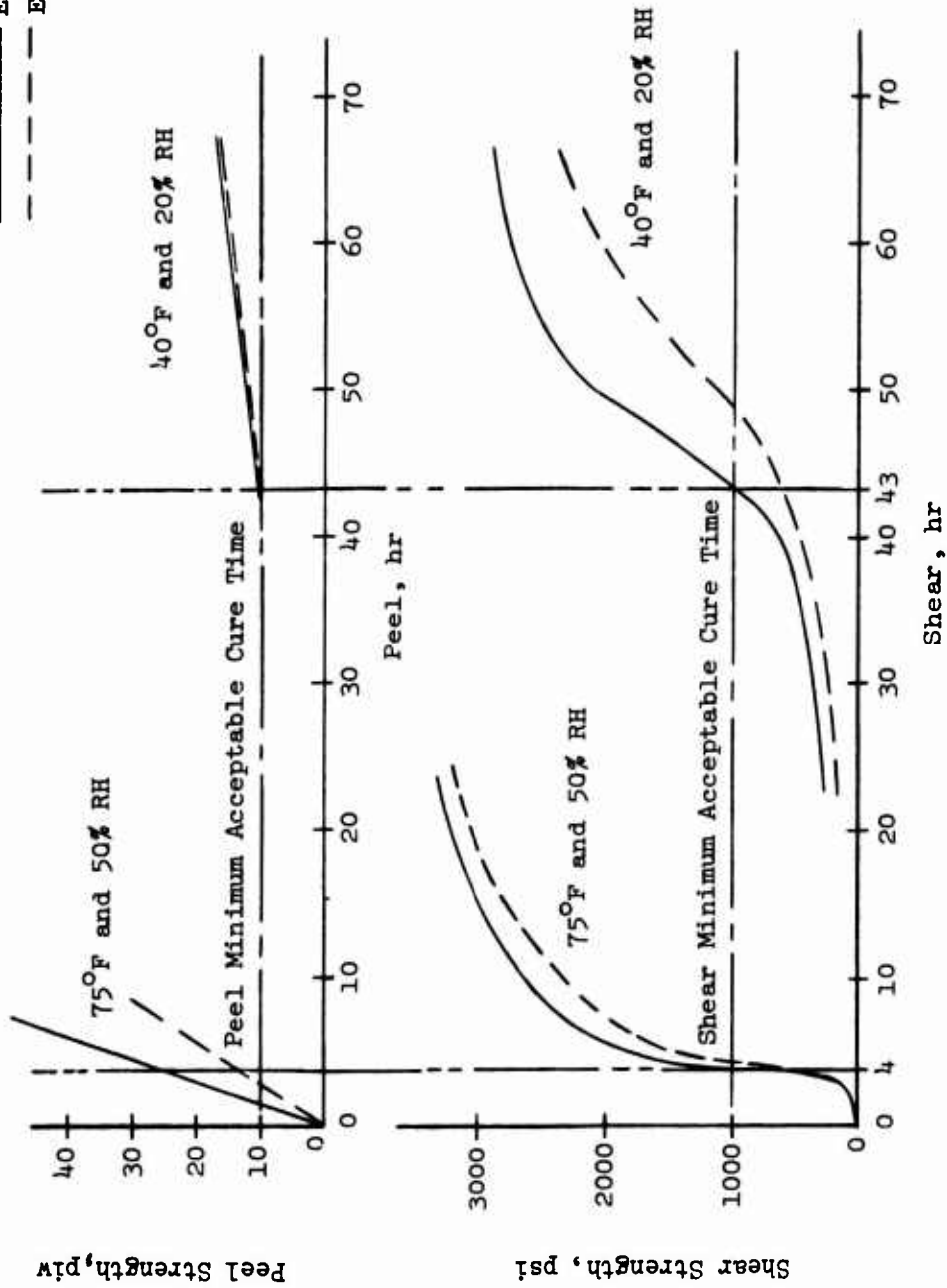

Figure 16. Minimum Peel and Shear Acceptable Cure Time.

the higher shear strength of EA 9309.2. The faster curing time to obtain minimum acceptable shear and peel strengths also favors EA 9320. For these reasons, EA 9320 is being recommended as the adhesive for field-replaceable pockets.

ADHESIVE PACKAGING OPTIMIZATION

TYPES OF PACKAGES

One of the tasks of this program was to evaluate the method of packaging the adhesive (selected for field repair kits). All the adhesives investigated for Reference 1, including the Hysol adhesive, were two-part systems consisting of proportions of adhesive and catalyst. These adhesives required mixing just prior to use because of the short working life of the adhesive. The two types of packaging that seemed most practical were:

- a) a kneading package (Figure 17)
- b) a plunger type package (Figure 18)

These two types of packages were selected for evaluation because they were both self-contained units; the adhesive and the catalyst were designed into one package separated by either a clamp (Figure 17) or a barrier (Figure 18). In addition, both types of packages were fabricated from transparent plastic; mixing could be accomplished in each package, with the clear plastic providing visual means of estimating proper adhesive mix.

The kneading package is utilized by simply removing the clamp which separates the two components (Figure 17) and by squeezing the plastic package from end to end with the fingers until the two components are mixed. The plunger type package is mixed by removing the clinch band located around the outside of the tube and pressing the tube with the fingers to distort the internal barrier separating the adhesive from the catalyst. The distorted barrier allows the catalyst to mix with the adhesive when the dasher rod is plunged in and out, for a number of strokes, until the adhesive is mixed. The dasher rod is then removed by unscrewing and replaced by the nozzle. The dasher rod is rescrewed into the opposite end of the container and utilized as a plunger to extrude the mixed adhesive through the nozzle.

Since it was not known at the time of the investigation which adhesive would be selected as the final adhesive, both Hysol EA 9309.2 and EA 9320 were utilized to evaluate the methods of packaging.

Fifty grams of Hysol's paste adhesive EA 9309.2 and EA 9320 were packaged in the above types of packaging and were evaluated. The evaluation included ease of mixing at room temperature and at 40°F, time to mix, color differential for determining when it was properly mixed, ease of application, cost, and the susceptibility of the package to damage.

The results of the evaluation were as follows:

1. Both packages can be easily mixed at room temperature; however, plunger packages were impossible to mix at 40°F. The dasher rod could not be pulled through the cold resin, whereas the thin kneading type packages of adhesive were warmed by the hand and mixing was possible. These thin packages of adhesive could be placed in a breast pocket or under an arm pit to be warmed by the body to facilitate mixing in a cold climate.

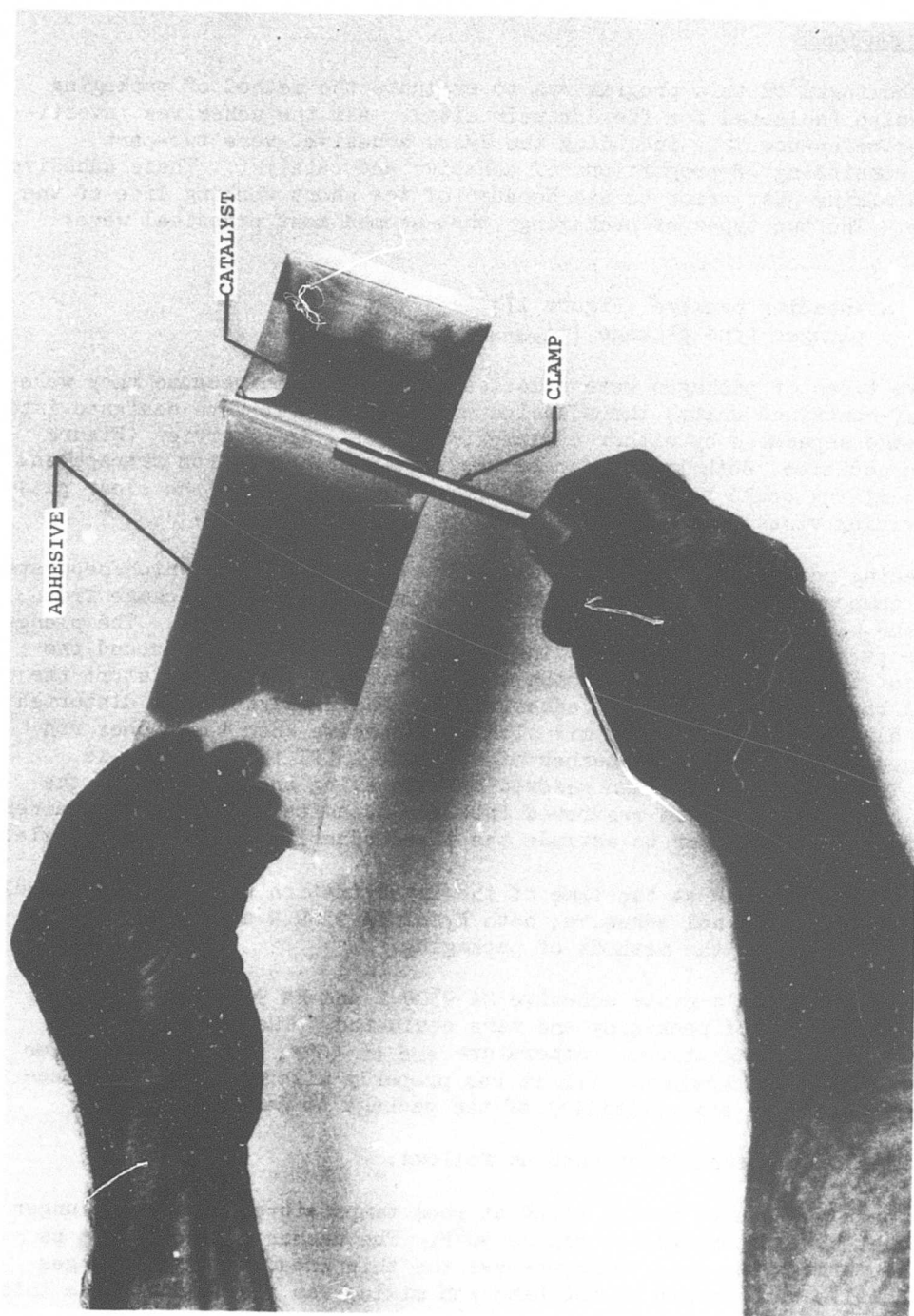

Figure 17. Kneading Type Adhesive Package Showing Clamp Being Removed.

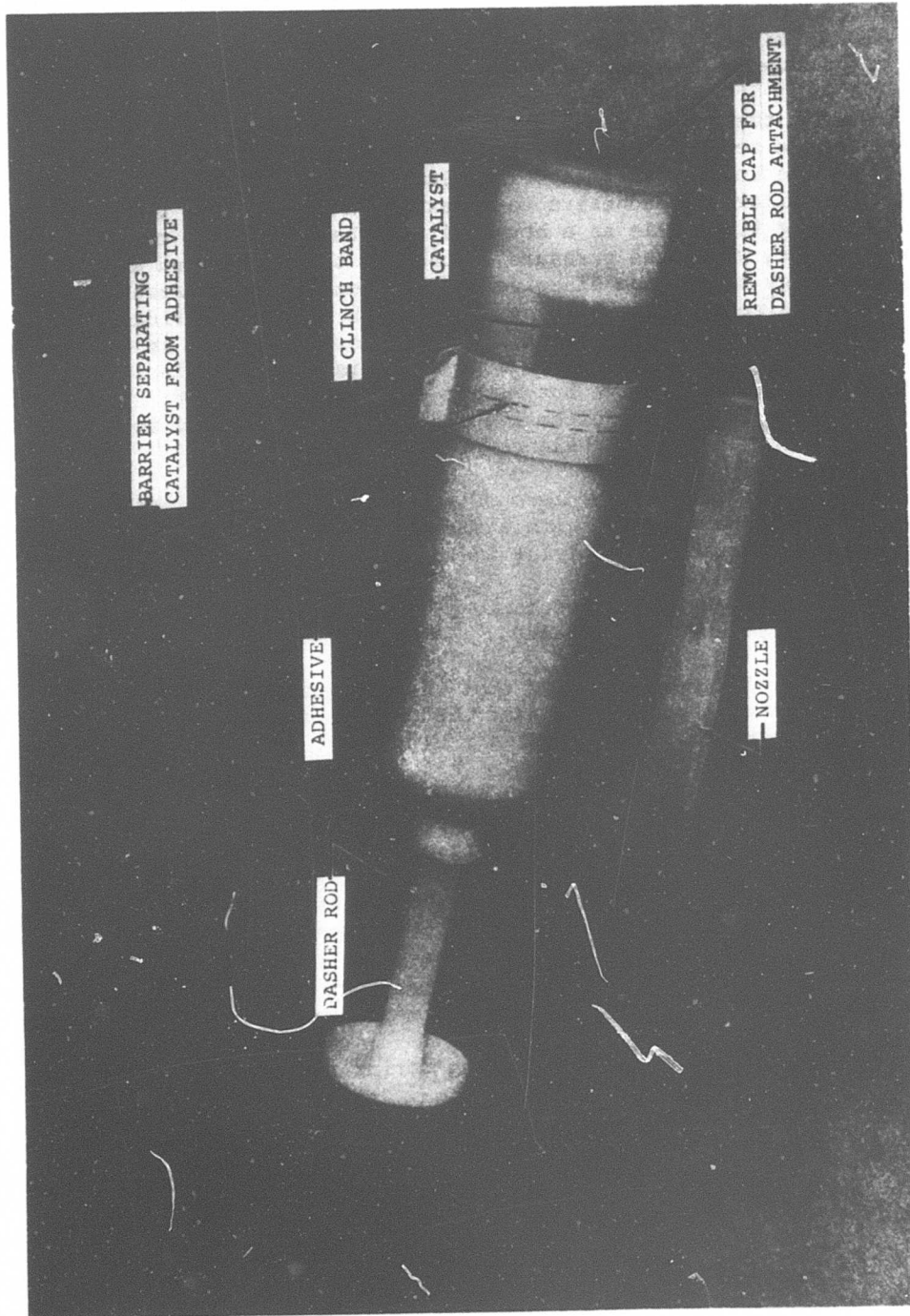

Figure 18. Plunger Type Adhesive Package.

2. Both packages can be thoroughly mixed in 6 to 8 minutes; however, the kneading type package retains a thin film of base resin on its surface and, although completely blended, gives the appearance of not being sufficiently mixed. The working life of the mixed adhesive for either type of package is 20 minutes.
3. After mixing, the adhesive must be extruded from the kneading type package into a separate open-mouth container (small cup) and then brushed on the bonding surface. The plunger type can be applied with a nozzle that allows the adhesive to be extruded directly on the surface, and then, using the nozzle as a brush, it can be spread out over the bond area. However, when hand pressure is used on the dasher rod of the plunger package to extrude adhesive out the nozzle, back pressure begins to force adhesive past the plunger at the back of the cartridge, and some adhesive is wasted. In addition, using the nozzle results in excessive adhesive on the pocket; in the spar area, it is not possible to apply a smooth, even coat of adhesive but rather a heavy, uneven coat. This method of packaging would require excessive adhesive to be applied to the blade and could result in a blade balance problem.

It became evident that, regardless of the type of adhesive package, the field kit should be supplied with a small cup for the mixed adhesive and a stiff bristle brush for applying the adhesive to the blade.

4. The kneading package is more economical, being approximately half the price of the plunger type package.
5. It was discovered during handling that the thin curing agent of the plunger type package could leak past the barrier and mix with and harden the base resin. The kneading package was also susceptible to leaks at the clamp.
6. It was noted that both adhesives had approximately the same consistency and were comparable as far as mixing in either package.

Both methods of packaging needed some improvements. However, the difficulty of mixing the plunger type package at 40°F was sufficient to eliminate it as a field package. It appeared feasible that the kneading package could be redesigned without leaking at the barrier; therefore, it was selected as the method of packaging for the field-replaceable pocket.

Further refinements were made in packaging during the field installation; these are discussed under field installation, page 110.

FIELD REPAIR KITS

FIELD-REPLACEABLE POCKET KIT

The kit components necessary to replace one CH-54B main rotor blade pocket in the field consist of:

- 1 EWR 38633 field-replaceable pocket
- 2 Rubber seals to seal ends of pocket
- 2 Pieces of 80-grit sandpaper to smooth and remove old adhesive on spar
- 1 Plastic cup to contain adhesive
- 1 50-gram package of EA 9320 Hysol adhesive
- 2 Brushes to apply adhesive
- 2 Spatulas to mix adhesive
- 1 Pair of plastic gloves to avoid contamination of spar and pocket after cleaning with alcohol
- 4 Assorted shims to properly space pocket on blade during installation
- 2 Plastic scrapers to remove loose and old adhesive on spar
- 1/4 Packet of cheesecloth to clean and apply alcohol to pocket, spar and backwall spacers
- 1 Roll of masking tape to mask off nonworking area
- 2 Backwall spacers to align pocket trailing edge with adjacent pockets for #1 thru #9 pockets only)
- 1 Field repair manual instructions to facilitate installation
- 1 Small bottle of commercial grade alcohol solvent to clean pocket, spar and backwall spacers

The field kit is comprised of two boxes: box number 1 contains all the components except the alcohol, which is contained in box number 2. These items are shown in Figure 19. They are sufficient to make one field repair. The only additional requirement beyond the above components is a wooden or rawhide mallet to use in conjunction with the plastic scraper. The mallet is a standard tool that is available in the field.

FIELD REPAIR MANUAL

The field pocket repair manual (Volume II of this report) has undergone several revisions by actual field experimentation where service men installed a total of 35 field-replaceable pockets on blades at the Sikorsky Aircraft Plant and in the field at Fort Wainwright, Alaska, and Fort Eustis, Virginia. The manual contains all the illustrations and instructions needed by a repairman to remove a production pocket and install a field-replaceable pocket.

BONDING FIXTURE KIT

A bonding fixture kit is required to remove and install a field-replaceable pocket. The bonding fixture kit consists of a bonding fixture tool and a pair of commercial nippers (Figure 20). The nippers are used to remove the damaged pocket from the blade by following the directions and illustrations outlined in the instruction manual. The bonding fixture tool is installed

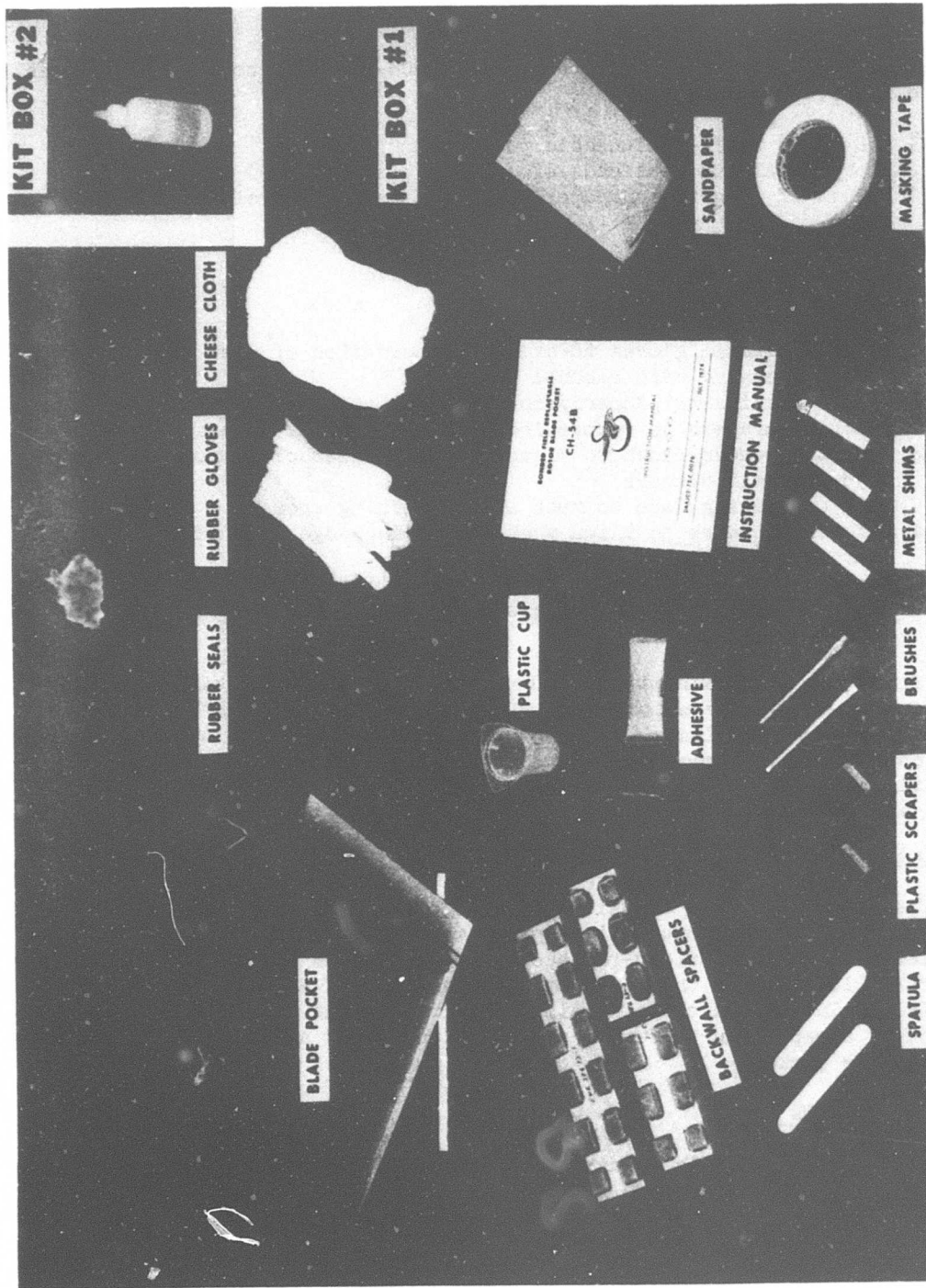

Figure 19. Field-Replaceable Pocket Kit.

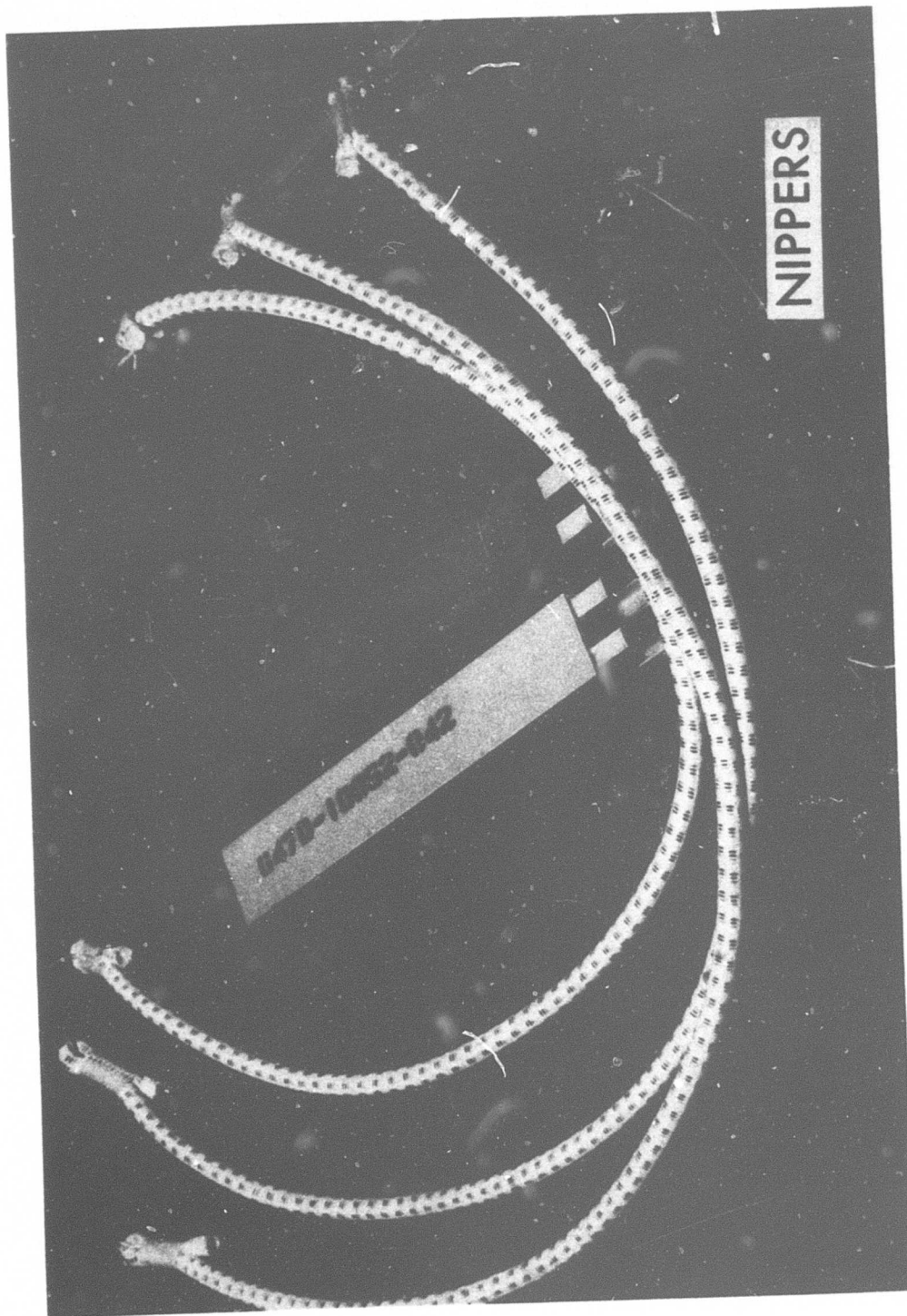

Figure 20. Bonding Fixture Kit.

on the blade as a final operation to retain the field-replaceable pocket in place while the adhesive is curing. The tool is designed with a rear channel to align the trailing edge of the newly installed pocket with adjacent pockets while two hollow square tubes retain the leading-edge pocket skins flush against the spar (Figures 10 and 21). The fixture is designed with three bungee cords which provide pocket-to-spar pressure at the two sides and backwall. The tool is reusable, capable of making an indefinite number of repairs. For multiple pocket replacement, additional tools are necessary.

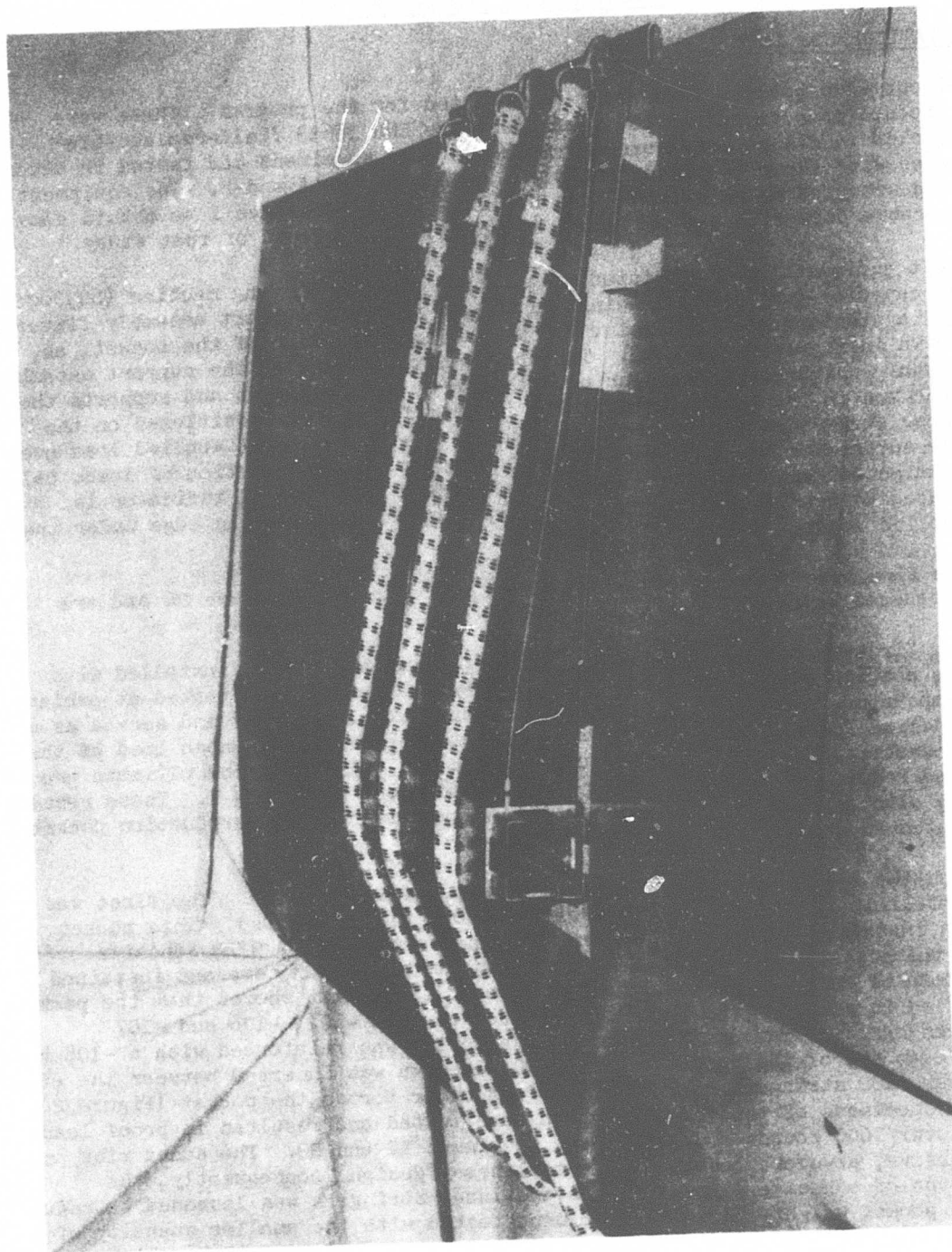

Figure 21. Bonding Fixture Installed on Blade.

POCKET STATIC AND DYNAMIC TESTS

STATIC PROOF LOAD TESTS

Twenty-two pockets were proof load tested for the program. Three were production pockets and the remainder were EWR 38633 field-replaceable pockets. All pockets were assembled on spar specimens and tested in accordance with the proof load test plans of Appendixes A and B. The equipment and setup were the same as that utilized under Reference 1 to obtain comparable data with the universal and production pockets of that study.

Test equipment used consisted of a Riehle tensile testing machine (60,000 lb capacity), a static loading fixture, a reaction support assembly fixture, and a standard dial indicator for measuring deflection of the pocket, as shown in Figures 22 and 23. The specimen was placed in the support assembly fixture, which grips the spar on either side of the pocket and supports the specimen in the test machine. The loading fixture was positioned on the upper surface of the pocket, distributing the test machine applied load over the surface of the pocket in accordance with the distribution of loads calculated for the outboard pocket in Reference 1. A dial indicator is placed to read the deflection of the pocket at the trailing edge under the applied loads.

The final proof load results are shown in Table 4 and Figure 24 and are discussed below.

The first three specimens consisted of production pockets installed with one coating of EA 9320 adhesive. They were assembled and tested at ambient temperature and humidity conditions in the test laboratory and served as a baseline for all field-replaceable pocket specimens. The mean load of the production pockets was 1650 pounds, which was well above the ultimate proof load requirement of 565 pounds established under Reference 1. These results are also typical of the loads sustained by universal and production pockets tested in that study.

Nineteen field-replaceable pockets were proof load tested. The first was a preliminary concept of EWR 38633 (without the -108 ribs). This pocket was installed on a spar specimen with one coating of EA 9320 adhesive in the pocket-to-spar area. It was subjected to proof test and sustained a load of only 280 pounds. Examination of the pocket showed that the pocket failed in shear at the trailing edge between the -102, -106 and -107 stringers. To remedy the problem, the design was reinforced with a -108 rib on each end of the pocket, and EA 9320 adhesive was inserted between the eight inner -102 stringers to provide uniform shear across the pocket (Figure 2). Two specimens of this configuration were tested and resulted in proof loads of over 1600 pounds. See Table 4, specimens R2 and R3. The added ribs and adhesive, however, resulted in a tail-heavy design; consequently, the amount of adhesive placed between the inner stringers was lessened to reduce the pocket weight. A third specimen, tested with the smaller quantity of adhesive, maintained a proof load of 1290 pounds before failure, which far exceeds the proof load requirement of 565 pounds (Table 4, specimen R4). Two additional specimens were tested, maintaining proof loads of 1175 and

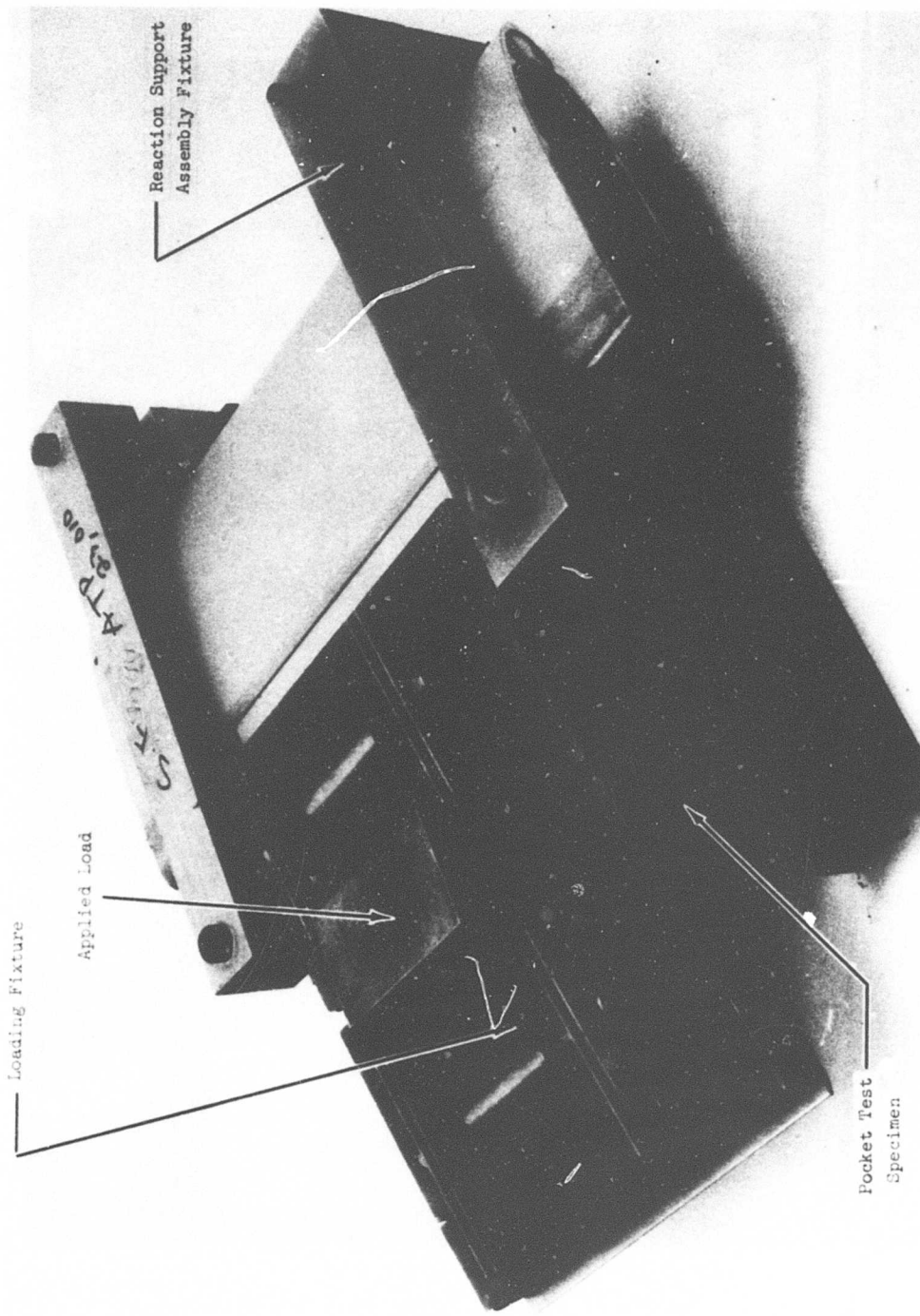

Figure 22. Pocket Specimen Fixtures.

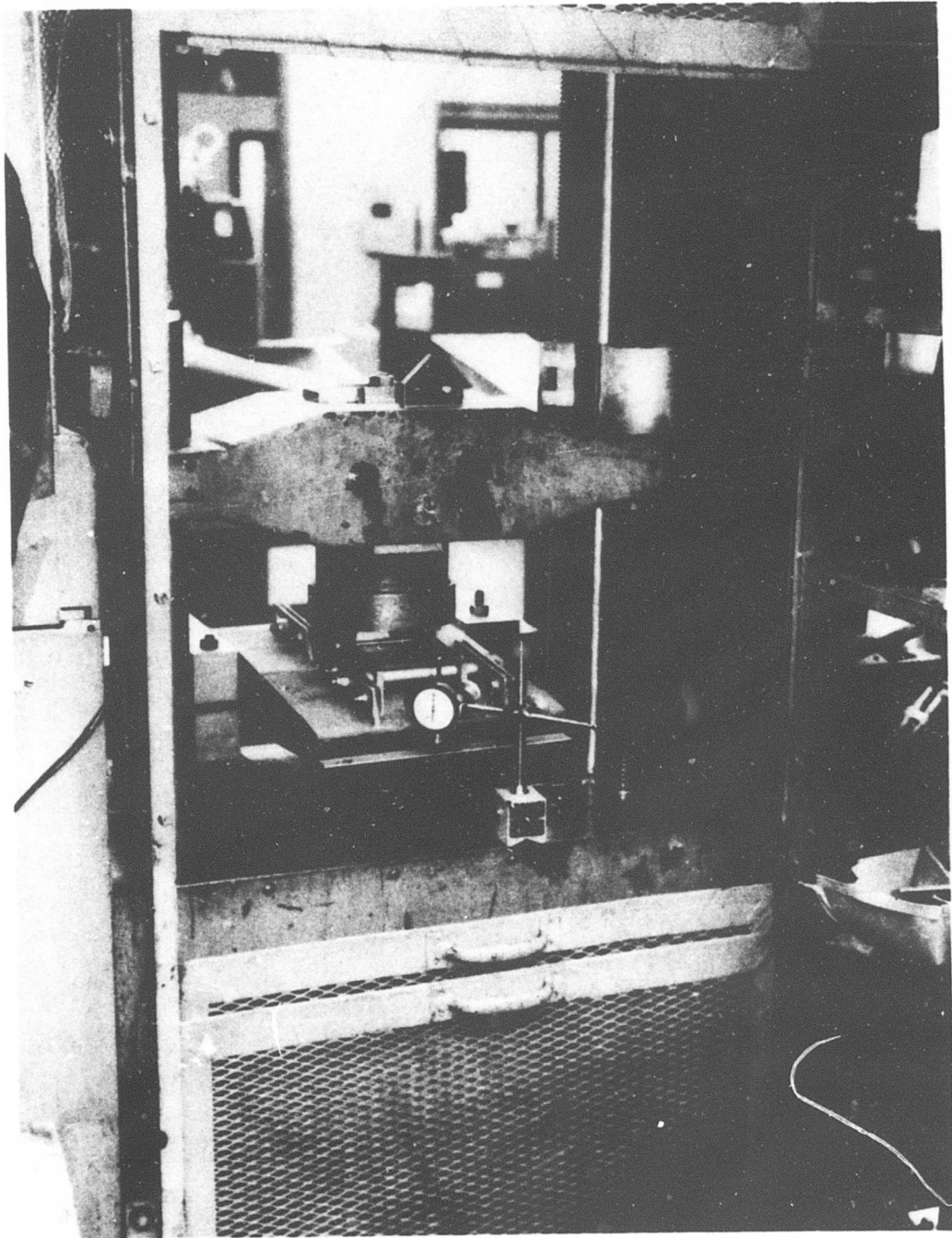

Figure 23. Pocket Proof Load Setup in Tensile Machine.

TABLE 4. PROOF LOAD TEST RESULTS

| Specimen No. | Specimen Type Pocket | Test Condition | Deflection (in.) | Ultimate Load (lb) |
|--------------|----------------------|----------------|------------------|--------------------|
| P1 | Production | (1) | .631 | 1725 |
| P2 | Production | (1) | .590 | 1700 |
| P3 | Production | (1) | .598 | 1600 |
| R1 | Replaceable | (1)(6) | | 280 |
| R2 | Replaceable | (1)(5) | .610 | 1675 |
| R3 | Replaceable | (1)(5) | .650 | 1605 |
| R4 | Replaceable | (1) | .520 | 1290 |
| R5 | Replaceable | (2) | .450 | 1300 |
| R6 | Replaceable | (2) | .353 | 1175 |
| R7 | Replaceable | (2) | .450 | 1150 |
| R8 | Replaceable | (3) | .531 | 1190 |
| R9 | Replaceable | (3) | .380 | 1000 |
| R10 | Replaceable | (4) | .345 | 1100 |
| R11 | Replaceable | (4) | .450 | 1100 |
| R12 | Replaceable | (1) | .475 | 1175 |
| R13 | Replaceable | (1) | .495 | 1235 |
| R14 | Replaceable | (3) | .513 | 1200 |
| R15 | Replaceable | (4) | .410 | 1175 |
| R16 | Replaceable | (1)(7) | .510 | 1235 |
| R17 | Replaceable | (1)(7) | .515 | 1245 |
| R18 | Replaceable | (1)(8) | .495 | 1220 |
| R19 | Replaceable | (1)(8) | .512 | 1237 |

- (1) Regular application of paste adhesive on spar/pocket joint @ 70°F.
- (2) Additional paste adhesive on spar/pocket joint @ 70°.
- (3) Specimen @ 40°F ambient for 40 hr. Used 3 heat packs on each side. Each pack on for 25 minutes for total of 1¼ hour. Tested within 1 hour.
- (4) Specimen @ 75°F ambient for 1 hr. Used 2 heat packs, 1 on each side for 1 hr. Tested within 1 hour.
- (5) Excessive adhesive between -102 stringers. Not representative of final design.
- (6) Initial field-replaceable pocket. Not representative of final design.
- (7) Replacement of a field-replaceable pocket.
- (8) Final design with one-piece outer skin.

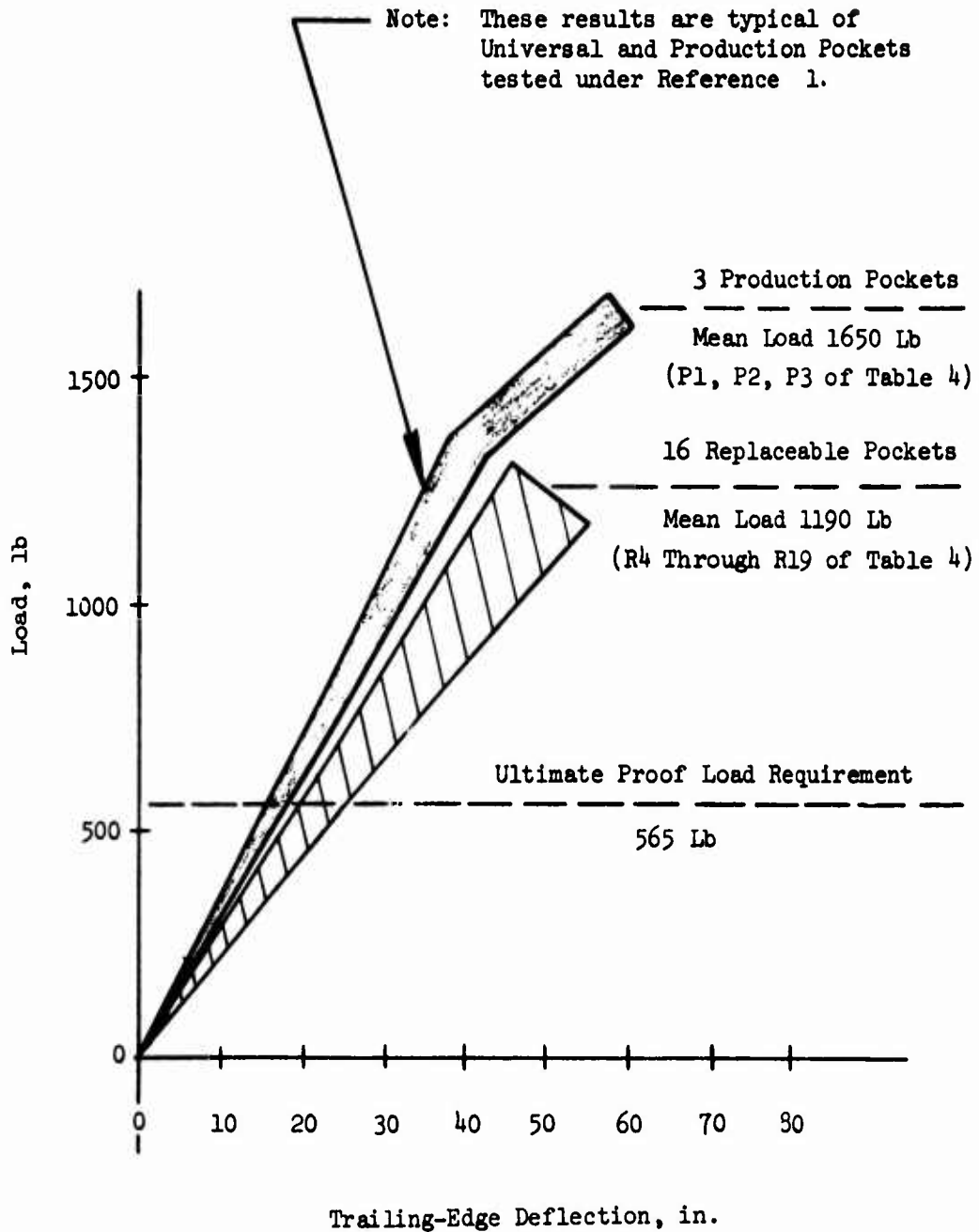

Figure 24. Proof Load Test Comparison.

1235 pounds before failure (specimens R12 and R13). Therefore, the design was considered to be satisfactory with the lesser amount of adhesive.

Three more pockets were static tested utilizing additional paste adhesive on the unsupported skin area. See Appendix A, Figure A-1. The values (specimens R5, R6 and R7) were essentially the same as the results shown for the normal application of adhesive applied for specimens R4, R12 and R13. The reason why the specimens of both categories sustained the same load is that the weak link is in shear between the stringers at the aft of the pocket and not compression of the pocket skin at the spar backwall. These pockets were also tested with and without backwall spacers, and there was not any discernible difference in the ultimate load of either specimen. The main reason is that the flange on the spacer supports the pocket skin when a 1/8-inch and 1/4-inch gap exists between the pocket and the backwall of the spar. A typical specimen with a backwall spacer is R12 of Table 4, sustaining a load of 1175 pounds.

Twenty-four chemical heat packs were utilized for curing six pockets installed on spar segments prior to proof loading these specimens. The purpose of heat packs was to estimate the effect of heat during pocket installation on specimens maintained at ambient 40°F and 75°F and then proof load tested within 1 hour. The pockets were assembled on spars, and the bonding fixture was installed similar to other pocket installations except that the chemical heat packs were placed between the bungee cords and the pocket skin (Figure 25). The three specimens at 75°F required only one heat pack per side for 1 hour and then tested within 1 hour for a total of 2 hours. The results are shown for specimens R10, R11 and R15 in Table 4.

The spars for the three specimens at 40°F were subjected to 40°F in a walk-in cooler for approximately 40 hours. One heat pack per side was utilized at the beginning of the cure. However, because the spar provided such a large heat sink, additional heat packs were installed every 25 minutes to maintain heat to the bond being cured. Three heat packs to a side were used during the test. The results are shown for specimens R8, R9 and R14.

Figure 26 shows graphically the temperature at the pocket-to-spar bond for both the 75°F and 40°F chemical heat pack tests.

The chemical heat packs were #AS-CHP-4000, purchased from Airline Systems, San Carlos, Calif. Standard 7 in. x 12 in. heat packs were used with the 12-in. direction spanwise on the blade and the pocket-to-spar bond area centered on the 7-in. width. All pockets bonded with heat packs, either proof load or fatigue specimens, were successfully tested even though the ends of the pockets were not pressed tight to the spar. When the heat pack is activated, it swells and shortens itself in the 12-in. direction. To properly bond a pocket to a spar, the heat packs should be 7 in. x 15 in., or an .064-in.-thick caul plate should be inserted under the present heat pack to apply pressure to the ends of the pocket skin.

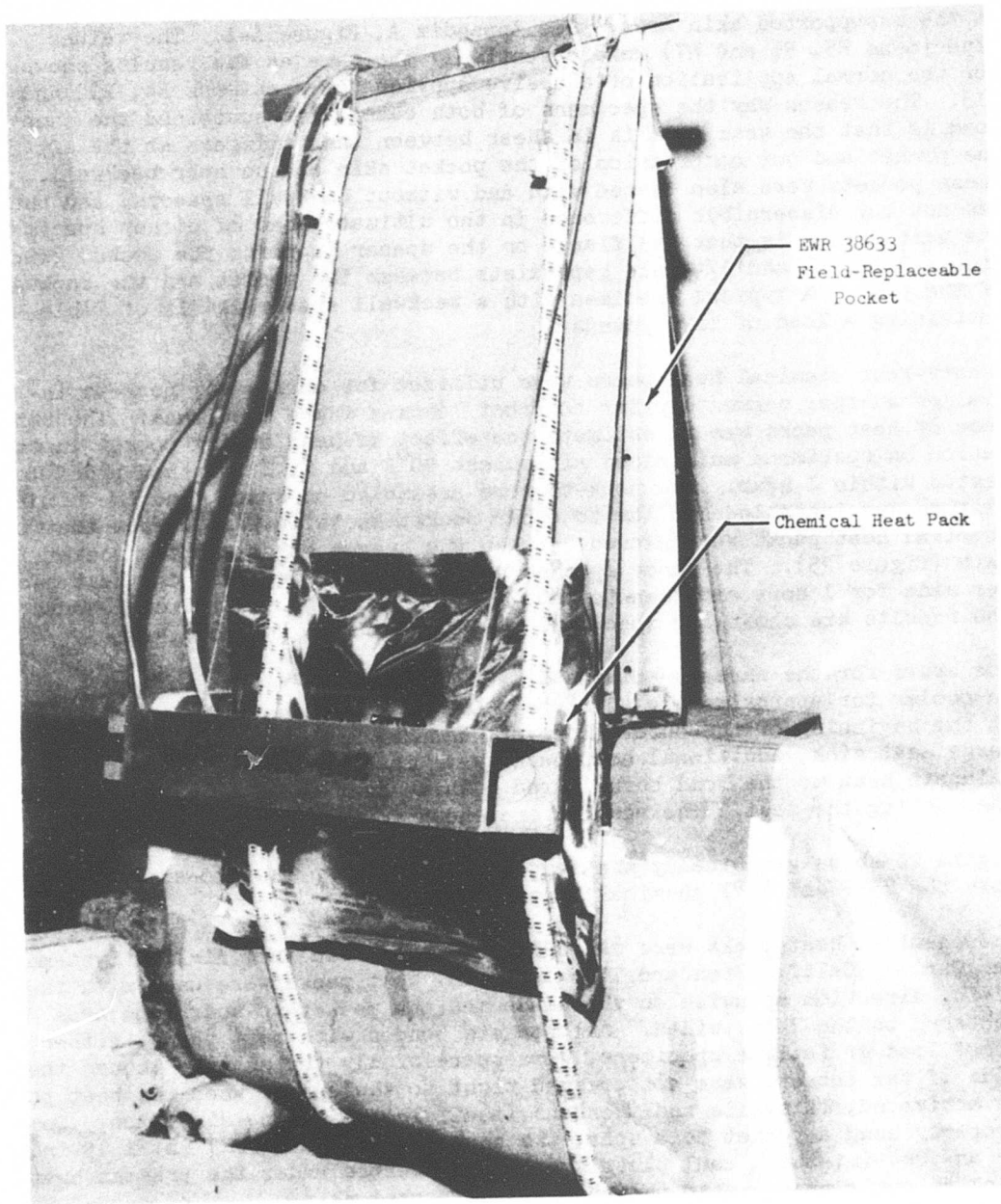

Figure 25. Installation of Chemical Heat Packs for Pocket Bonding.

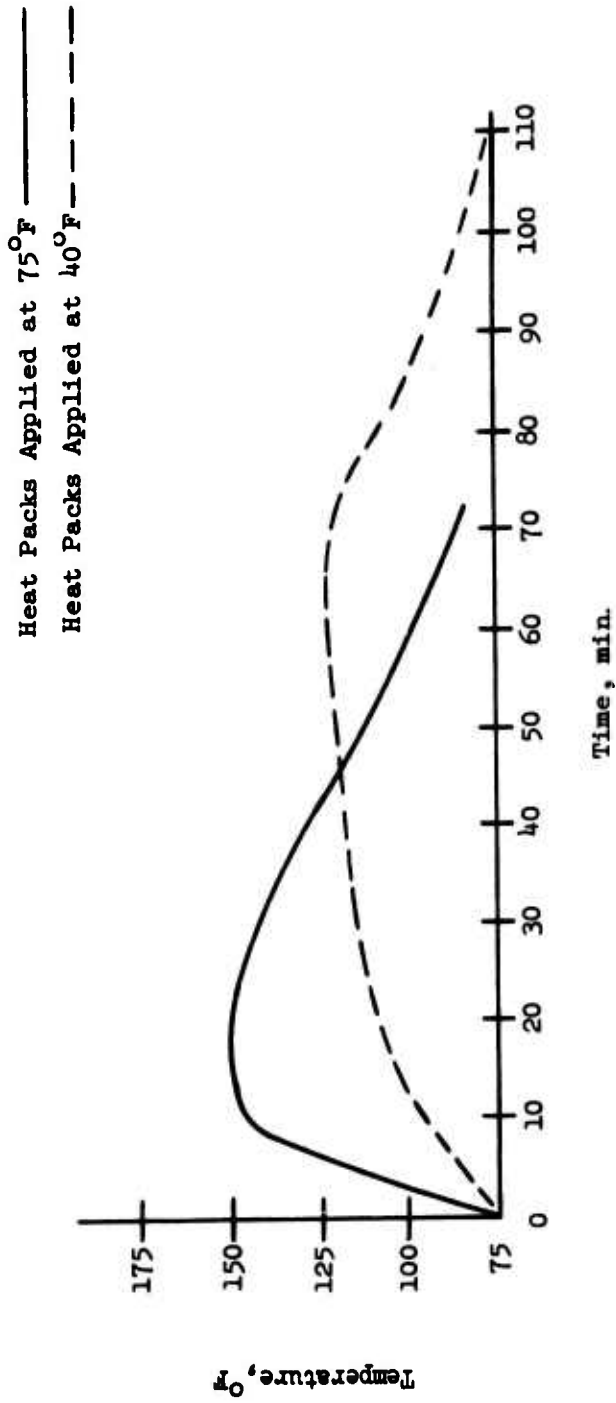

Figure 26. Temperature at Pocket-to-Spar Bond vs Time.

The heat packs can be used with the pocket installation tooling by simply putting the bungee cords under the side pressure bars, instead of over them, and then installing the heat packs under the bungee cords, over the bond area. They are neatly packaged two to a box complete, even to their own water supply. The contractor would suggest they be used as a separate kit because of the quantity required in a cold climate. At colder temperature (40°F), as many as six heat packs are required per pocket.

Two additional specimens were tested to estimate the resulting proof load by removing a field-replaceable pocket from a spar and replacing it with another field-replaceable pocket. The pockets were installed at 70°F using a regular application of paste adhesive on the spar/pocket joint. The results obtained (R16 and R17) were similar to proof loads sustained by other specimens.

The last two pockets tested consisted of the finalized design, EWR 38633 Revision D, with the one-piece outer skin. These were also assembled at 70°F using a normal amount of paste adhesive. The results are shown as specimens R18 and R19.

As can be seen by Figure 24, there was very little spread in load/deflection regardless of the four test conditions. Failure occurred in shear at the trailing edge of the stringer (-102, -106 and -107) joint. The average load of the EWR 38633 pocket for R4 through R19 is 460 pounds less than the average load of the production pocket; however, the EWR 38633 pocket can sustain more than twice the ultimate proof load requirement of 565 pounds established under Reference 1.

FATIGUE TESTS

Summary

Results of fatigue tests indicated that the EWR 38633 field-replaceable pockets were stronger than the production pockets. Test procedures, results and conclusions are presented below. The Fatigue Test Plan is included in Appendix C.

Test Design

Factors which could contribute to in-service pocket failures are:

- a. Vibratory spanwise strain at the bond
- b. Aerodynamic loads bending the pocket
- c. Inertia loading bending the pocket
- d. Mechanical damage due to foreign objects

Analysis confirms that the most significant loading is the vibratory spanwise strain at the pocket-to-spar interface. The CH-54B blade pockets are bonded to the spar at points where the spar experiences relatively high vibratory spanwise stresses, and are therefore subjected to vibratory strains transmitted through the bond as the pocket conforms to the spar curvature.

These tests were designed to provide a comparison of production and field-replaceable pockets under this type of loading. Pocket specimens of

each type were subjected to three levels of vibratory loading for up to 3×10^6 cycles at each level. Each pocket was inspected for damage at regular intervals. Criteria for failure were established which were based on service requirements, that is, evidence of a crack or disbond which would necessitate repair or replacement of the pocket in service.

In addition to evaluating correctly assembled field-replaceable pockets, three specimens were tested which had deliberately been bonded with undesirable process variations such as old adhesive and improperly mixed adhesive. These tests provide a basis for evaluating the structural effect of procedural errors in field replacement.

Specimen Configuration

Each specimen was made from a 131-inch length of CH-54 spar with special end fittings to adapt to the test facility. Each specimen was fitted with five pockets as shown in Figure 27. The pocket configurations and locations are detailed in Table 5.

The fatigue specimens containing replaceable pockets were first bonded with production pockets per production procedures. The pockets were then removed to expose the residual adhesive for subsequent bonding of replaceable pockets with the selected adhesive to simulate conditions to be experienced in the field (See Figure 28).

Test Facility

The specimens were tested in the 60K and 100K blade test facilities shown in Figures 29 and 30 respectively. Figure 31 is a schematic representation of the blade test stand. Centrifugal loading was simulated by applying a static tensile load to the specimen through compressed rubber washers (steel washer springs in the 60K machine). The machine drive system comprises an adjustable eccentric and crank driven by a variable drive motor. One end of the specimen was excited by the crank to provide a small sinusoidal vertical displacement. Test frequency was increased until, at the resonant frequency of the pin-pin specimen, the blade adopted a resonant mode inducing the required levels of vibratory moment and strain.

The blades were positioned at an angle such that both edgewise and flatwise loadings were simultaneously applied. The ratio of NB to BR vibratory stresses was maintained at 77%. This represents the ratio of flatwise bending stress to bending stress at the bottom rear corner radius of the spar and is representative of most flight conditions. Each test condition was set up and monitored using amplitude measurements in the same manner as similar tests conducted during Reference 1.

During that program, one blade was instrumented, physically calibrated by means of deadweight, and used to establish the test conditions. Once each test condition was established, centrifugal load, blade angle, and vibratory amplitude at $1/4$ and $1/2$ span were recorded for use in establishing the test conditions on the subsequent test specimens, none of which were

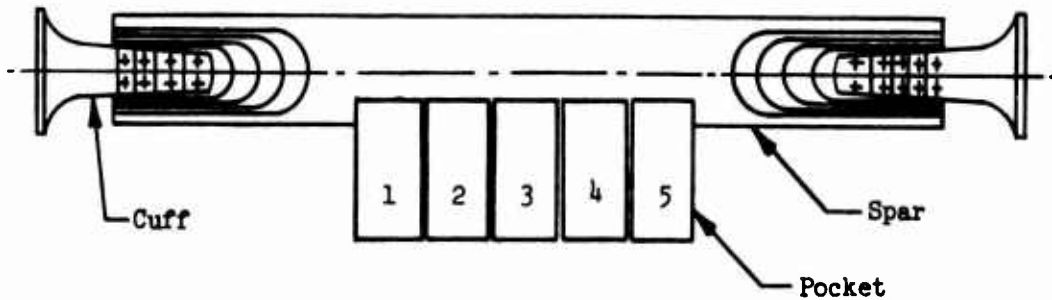

Figure 27. Typical Fatigue Specimen.

| TABLE 5, FATIGUE TEST - SPECIMEN CONFIGURATION | | | | | |
|--|---|---|--------------------------|--|---|
| Specimen Number: | Pocket Number | | | | |
| | (Crank End) | | | | (Col. End) |
| | 1 | 2 | 3 | 4 | 5 |
| 1 | Production Pocket Hysol Bond | Production Pocket Hysol Bond | Production Pocket AF6 | Production Pocket Hysol Bond | Production Pocket Hysol Bond |
| 2 | Replaceable Pockets, No Backwall Spacers Hysol Bond | | | | |
| 3 | Replaceable Pockets, Backwall Spacers Hysol Bond | | | | |
| 4 | Replaceable Pockets, Modified Backwall Spacers Hysol Bond | | | | |
| 5 | Replaceable Pocket Improper Hysol Mix | Replaceable Pocket Heat-Pack Hysol | Production Pocket AF6 | Replaceable Pocket 8 Mo. Old Hysol | Replaceable Pocket Bare Spar Hysol |
| 6 | Replaceable Pocket Bare Spar Hysol | Replaceable Pocket 8-Mo.-Old Hysol | Production Pocket AF6 | Replaceable Pocket Heat Pack Hysol | Replaceable Pocket Improper Hysol Mix |
| 7 | Replaceable Pocket 27-Mo.-Old Hysol | Replaceable Pocket Improper Hysol Mix | Production Pocket AF6 | Replaceable Pocket Bare Spar Hysol | Replaceable Pocket Hangar Cond Hysol |



Detail "A"

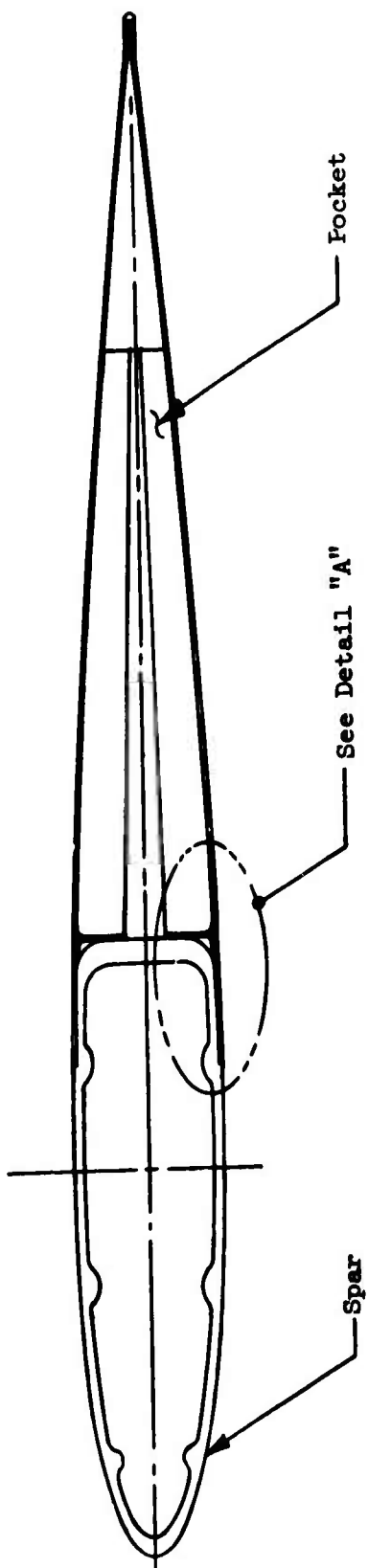

Figure 28. Cross Section Through Spar and Pocket.

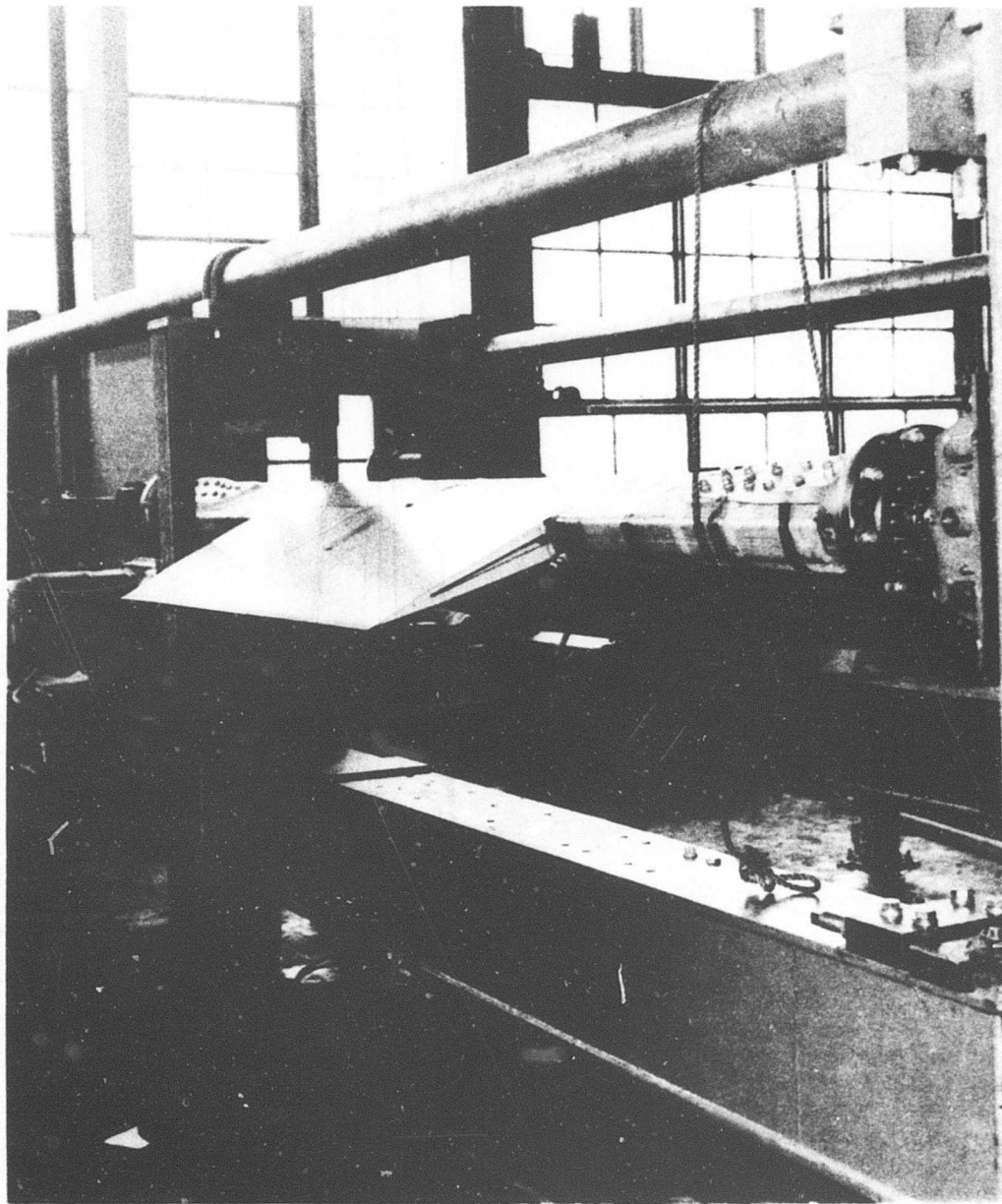

Figure 29. Specimen in 60K Lb Fatigue Test Machine.

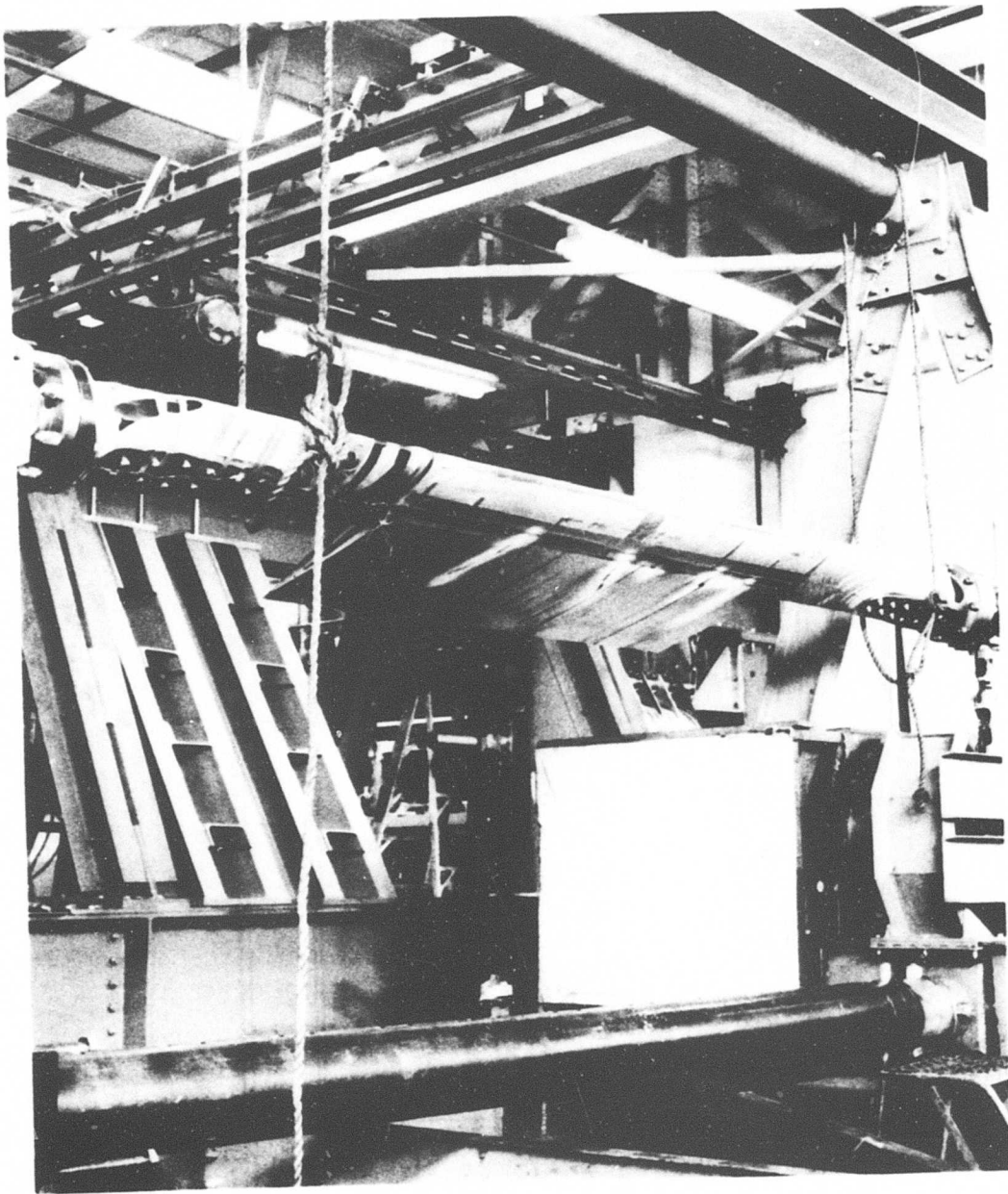

Figure 30. Specimen in 100K Lb Fatigue Test Machine.

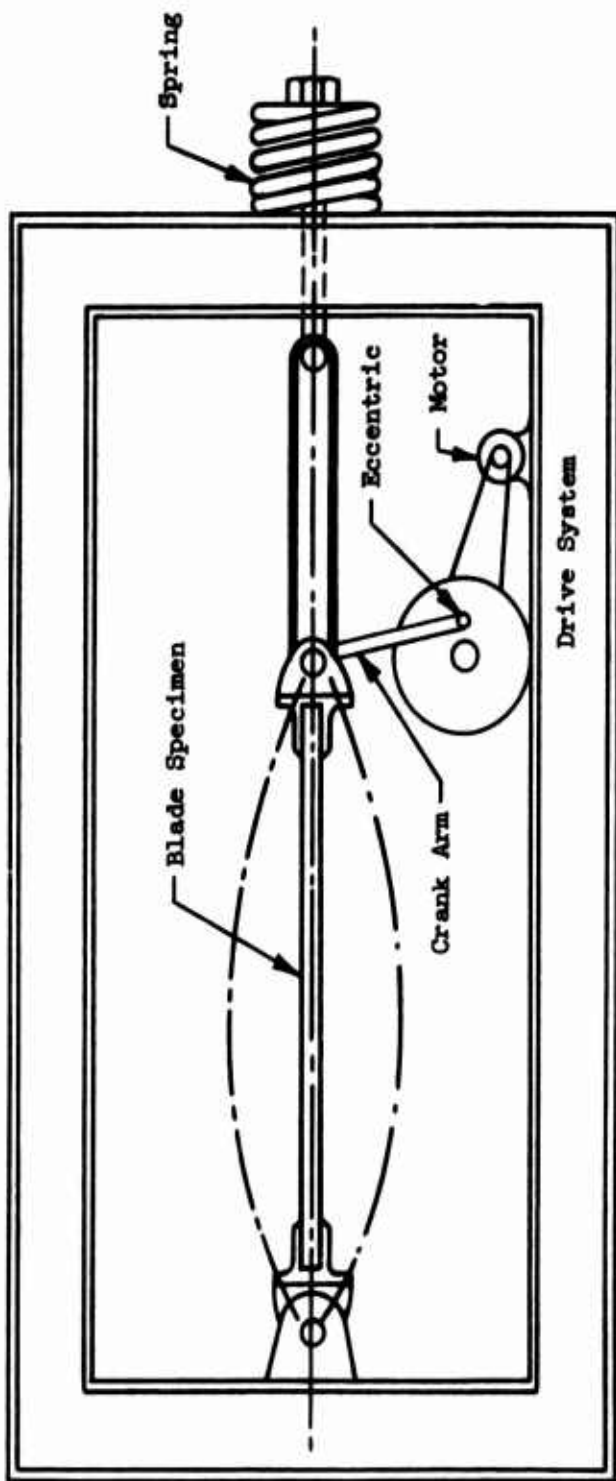

Figure 31. Schematic of Blade Test Machine.

strain gaged. The resultant spanwise BR stress distributions from the survey are shown in Figure 32.

Fatigue Test Procedure

The pin-pin resonant mode of testing produces a distribution of bending moment along the specimen; therefore, the stress experienced by each pocket is related to its position on the spar. From Figure 32 the stress for each pocket can be found for each of the three load levels at which the specimen was tested. Each specimen was tested for 3×10^6 cycles at maximum vibratory stress levels of ± 4000 , ± 7000 and ± 10000 psi and a steady tensile stress of 10500 psi until the test was completed or fracture of the spar occurred.

Approximately every $.5 \times 10^6$ cycles, the pockets were inspected visually and by coin tapping to detect cracks or disbonds.

Results

Test data of all seven specimens are summarized in Table 6. No representative damage was sustained at the first and second load levels, except for specimen 7.

The S/N curves plotted for these specimens are:

- a) Figure 33 showing S/N data for production pockets
- b) Figure 34 showing S/N data for replaceable pockets
- c) Figure 35 showing S/N data for replaceable pockets with backwall spacers
- d) Figure 36 showing S/N data for incorrectly bonded replaceable pockets.

Note: Damaging cycles to failure in Figures 33 through 36 indicate the time in cycles when failure occurred in the test pocket (production or field replaceable) by either cracks or bond separations.

Discussion of Results

Comparison of correctly bonded replaceable pockets data in Figures 34 and 35 shows no significant difference with or without backwall spacers and an improvement in strength over the production pocket of approximately 23%. Even with poor bonding techniques, the replaceable pockets showed a strength equivalent to the production configuration, with the exception of specimen 7.

The results for specimen 7, Figure 36, showed a significantly lower fatigue strength in the spar-pocket bonds of that specimen compared to specimens 5 and 6. This is believed to have been caused by a technician's wiping the primed interior surface of the pocket with methyl ethyl ketone before the adhesive was applied. This solvent removed the primer from the surface,

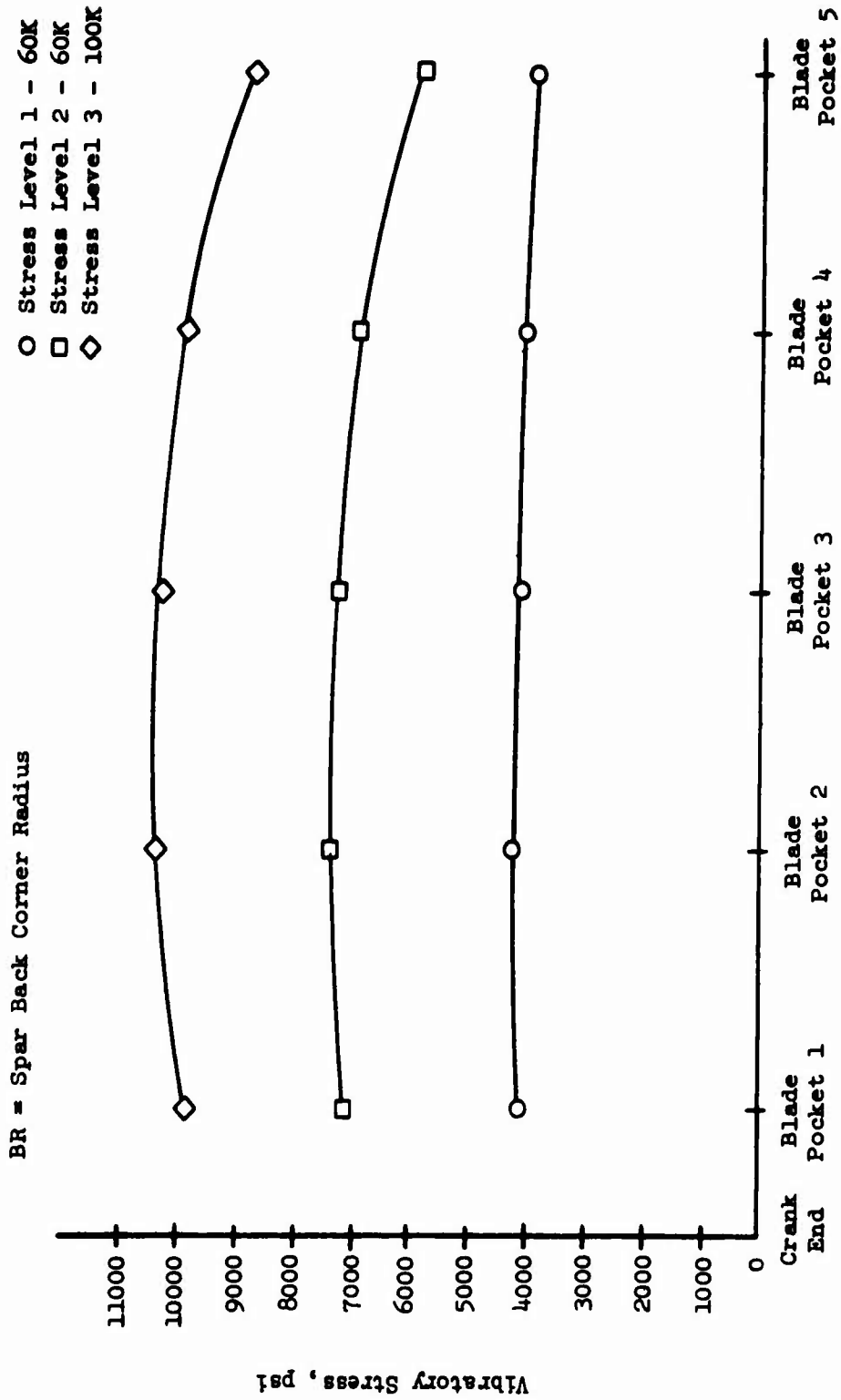

Figure 32. Vibratory BR Stress vs. Blade Pocket Position.

TABLE 6. FIELD-REPLACEABLE POCKET FATIGUE DATA

| Spec. No. | Pocket No. | Description | Damaging Cycles | Load Level (PSI) | | Data Remarks |
|-----------|------------|--------------------------------|-----------------------|------------------|-----------|-----------------|
| | | | | Steady | Vibratory | |
| 1 | 1.1 | Production Hysol Bond | 0.8 (10) ⁶ | 10500 | ± 9850 | Spar Failure |
| | 1.2 | Production Hysol Bond | 0.8 (10) ⁶ | 10500 | ±10400 | Spar Failure |
| | 1.3 | Production AF6 Bond | 0.5 (10) ⁶ | 10500 | ±10300 | Disbond |
| | 1.4 | Production Hysol Bond | 0.5 (10) ⁶ | 10500 | ± 9900 | Crack |
| | 1.5 | Production Hysol Bond | 0.8 (10) ⁶ | 10500 | ± 8800 | Spar Failure |
| 2 | 2.1 | | 3.0 (10) ⁶ | 10500 | ± 9850 | Crack |
| | 2.2 | Replaceable Pocket | 1.5 (10) ⁶ | 10500 | ± 7400 | Crack (Non Rep) |
| | 2.3 | Hysol Bond | 1.6 (10) ⁶ | 10500 | ±10300 | Crack |
| | 2.4 | No Backwall Spacer | 2.17(10) ⁶ | 10500 | ± 9900 | Crack |
| | 2.5 | | 3.0 (10) ⁶ | 10500 | ± 8800 | Runout |
| 3 | 3.1 | | 3.0 (10) ⁶ | 10500 | ± 9850 | Disbond |
| | 3.2 | Replaceable Pocket | 3.0 (10) ⁶ | 10500 | ±10400 | Runout |
| | 3.3 | Hysol Bond | 3.0 (10) ⁶ | 10500 | ±10300 | Disbond |
| | 3.4 | Backwall Spacer | 3.0 (10) ⁶ | 10500 | ± 9900 | Runout |
| | 3.5 | | 1.6 (10) ⁶ | 10500 | ± 8800 | Disbond |
| 4 | 4.1 | | 0.1 (10) ⁶ | 10500 | ± 9850 | |
| | 4.2 | Replaceable Pockets | 0.1 (10) ⁶ | 10500 | ±10400 | |
| | 4.3 | Hysol Bond | 0.1 (10) ⁶ | 10500 | ±10300 | Spar Failure |
| | 4.4 | Modified Blackwall | 0.1 (10) ⁶ | 10500 | ± 9900 | |
| | 4.5 | Spacer | 0.1 (10) ⁶ | 10500 | ± 8800 | |
| 5 | 5.1 | Rep. Pocket Improper Hysol Mix | 0.5 (10) ⁶ | 10500 | ± 9850 | Disbond |
| | 5.2 | Rep. Pocket Heat Pack-Hysol | 2.3 (10) ⁶ | 10500 | ±10400 | Runout |
| | 5.3 | Prod. Pocket AF6 Bond | 0.5 (10) ⁶ | 10500 | ±10300 | Disbond |
| | 5.4 | Rep. Pocket Old Hysol | 0.5 (10) ⁶ | 10500 | ± 9900 | Crack |
| | 5.5 | Rep. Pocket Bare Spar Hysol | 0.5 (10) ⁶ | 10500 | ± 8800 | Crack |

TABLE 6. Continued

| Spec. No. | Pocket No. | Description | Damaging Cycles | Load Level (PSI) Steady | Vibratory | Data Remarks |
|-----------|------------|--|-----------------------|----------------------------|-----------|-----------------|
| 6 | 6.1 | Rep. Pocket Bare Spar Hysol | 0.5 (10) ⁶ | 10500 | ± 9850 | Bond Void |
| | 6.2 | Rep. Pocket Old Hysol | 2.5 (10) ⁶ | 10500 | ±10400 | Bond Void |
| | 6.3 | Prod. Pocket AF6 Bond | 0.5 (10) ⁶ | 10500 | ±10300 | Bond Void |
| | 6.4 | Rep. Pocket Heat Pack-Hysol | 3.0 (10) ⁶ | 10500 | ± 9900 | Runout |
| | 6.5 | Rep. Pocket Improper Hysol Mix | 2.5 (10) ⁶ | 10500 | ± 8800 | Bond Void |
| 7 | 7.1 | Rep. Pocket Old Hysol Mod. Spacer | 2.0 (10) ⁶ | 10500 | ± 7100 | Disbond |
| | 7.2 | Rep. Pocket Improper Hysol Mix No Spacer | 1.0 (10) ⁶ | 10500 | ± 7400 | Disbond |
| | 7.3 | Production Pocket AF6 Bond | 1.0 (10) ⁶ | 10500 | ± 7300 | Disbond |
| | 7.4 | Rep. Pocket Bare Spar No Spacer | 2.5 (10) ⁶ | 10500 | ± 7000 | Disbond |
| | 7.5 | Rep. Pocket Bonded in Hangar Mod. Spacer | 0.5 (10) ⁶ | 10500 | ± 8800 | Disbond |

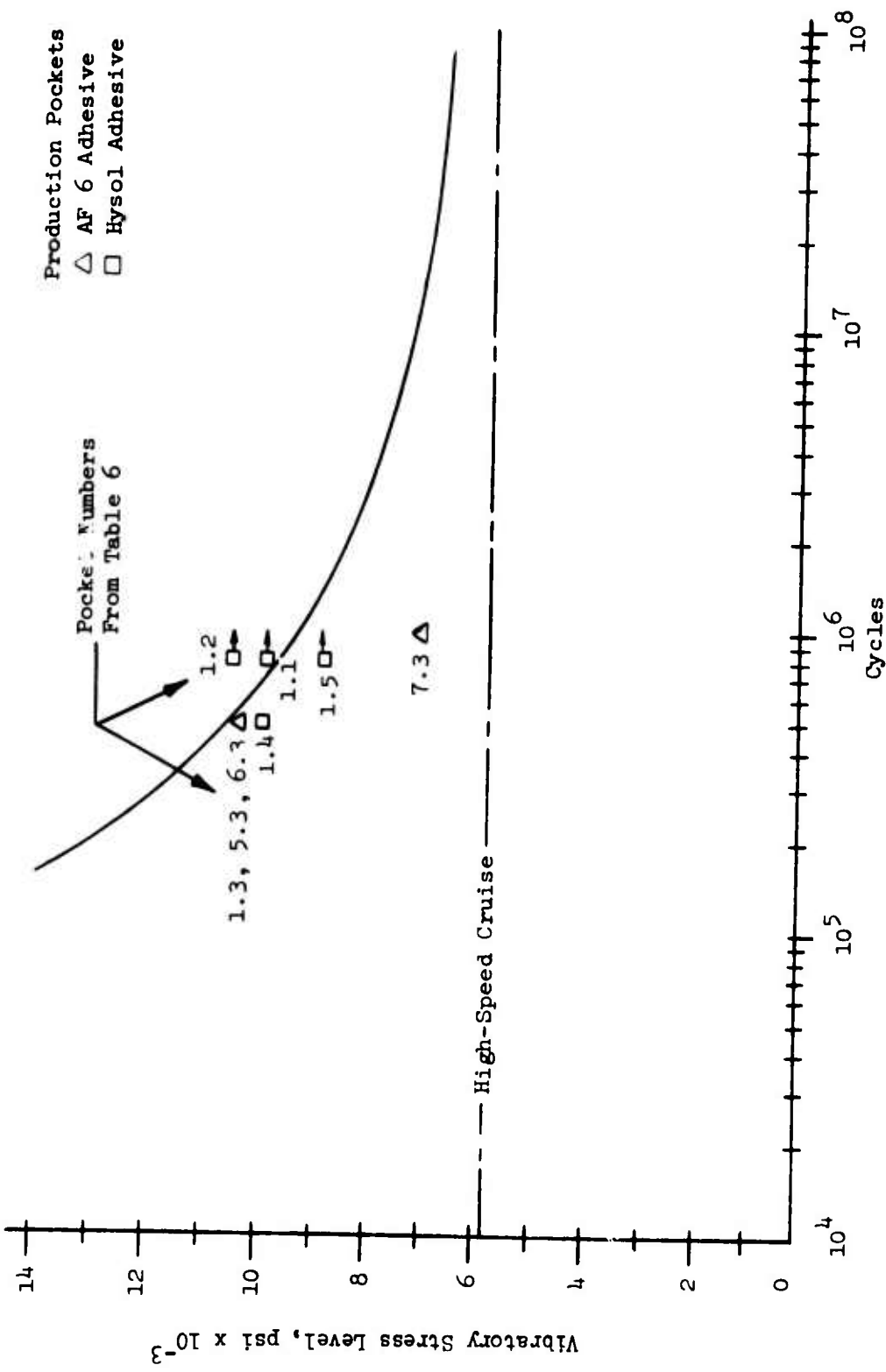

Figure 33. Damaging Cycles to Failure.

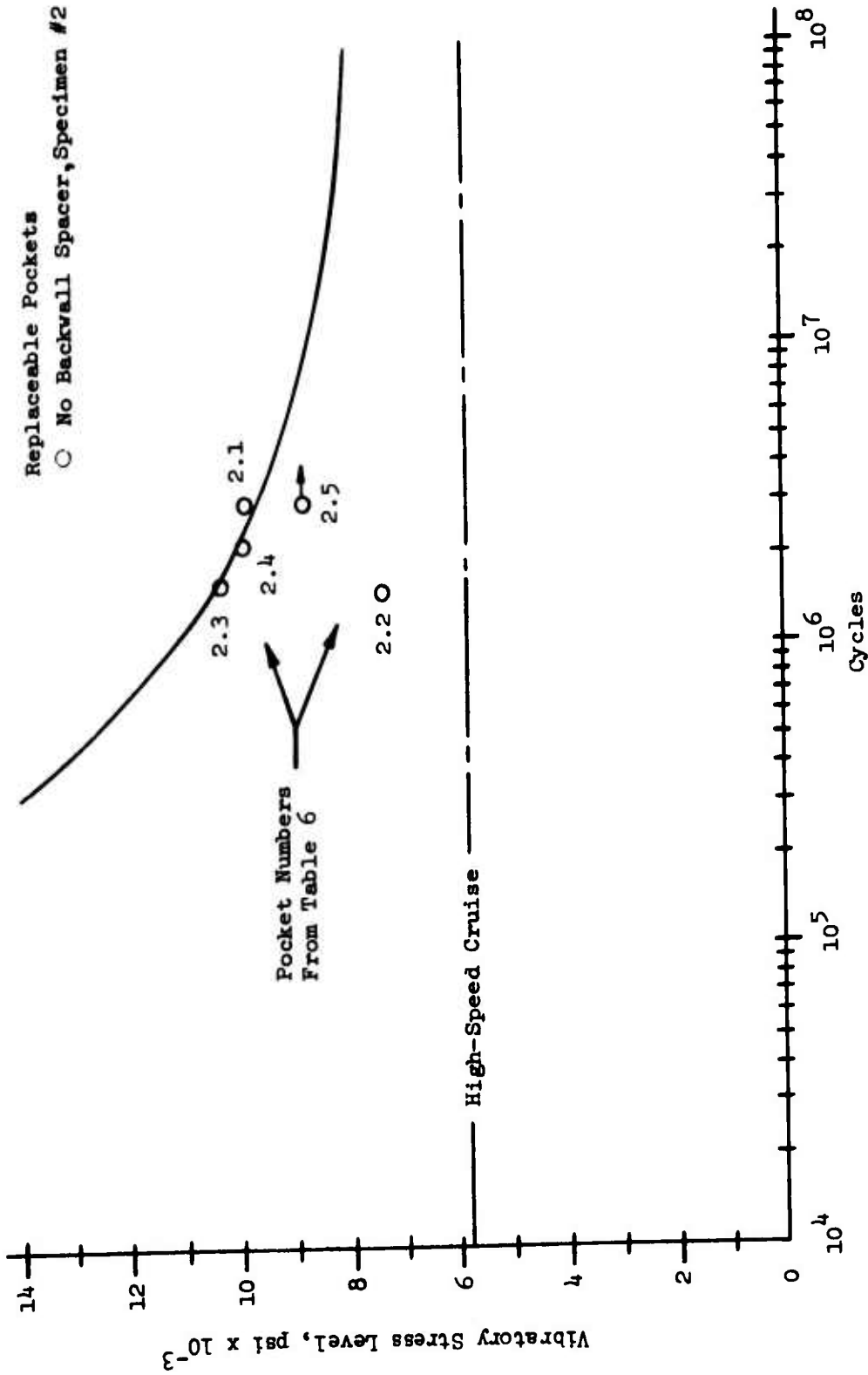

Figure 34. Damaging Cycles to Failure.

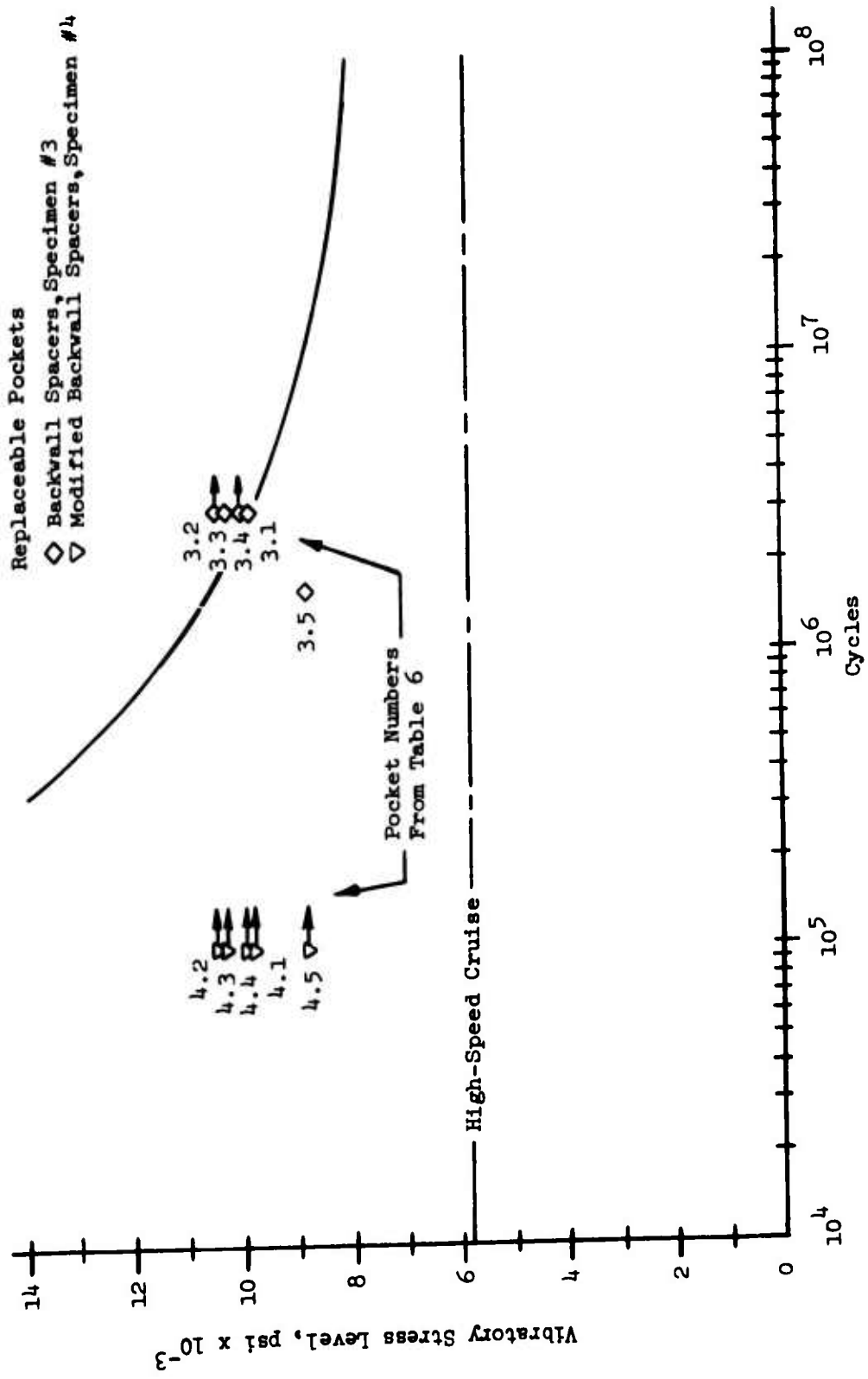

Figure 35. Damaging Cycles to Failure.

Replaceable Pockets Incorrectly Bonded

- ◇ No Backwall Spacer, Specimen #5
- No Backwall Spacer, Specimen #6
- △ Specimen #7: Backwall Spacers on Pockets 7.1 and 7.5 Only

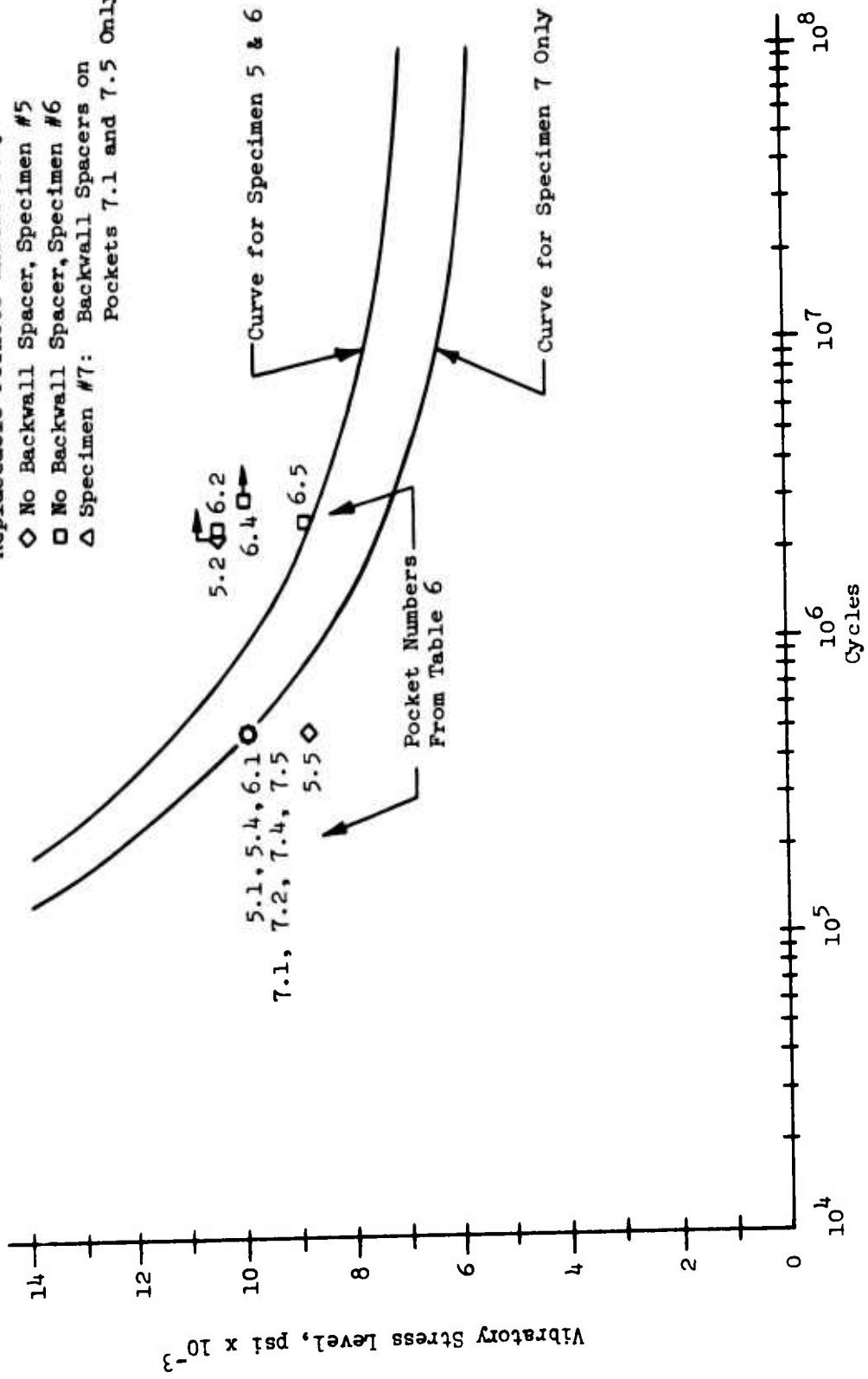

Figure 36. Damaging Cycles to Failure.

preventing formation of a satisfactory bond. For all the pockets, failure of the bonds of specimen 7 occurred between the adhesive layer and the pocket surface, rather than in the adhesive layer or at the spar-adhesive interface. This strongly implied that there was a fault in the pocket-adhesive interface.

Conclusions

The tests showed that the field-replaceable pockets were significantly stronger than the production configuration, and are structurally adequate for use on CH-54B blades as a field replacement provided proper procedures are used for installation.

Recommendation

Methyl ethyl ketone is not to be used for wiping surfaces prior to bonding. Alcohol should be used instead.

WHIRL TOWER TESTS

Summary

This portion of the report presents the results of the performance and endurance whirl tests performed on the CH-54B main rotor blade field-replaceable pockets in accordance with the Whirl Tower Test Plan, Appendix D.

The effects of field-replaceable pocket installation on CH-54B main rotor blade performance and balance were investigated. The functional adequacy of the field-replaceable pocket installation was demonstrated by a 25-hour endurance whirl test and a brief overspeed test.

It was concluded that:

- (1) The installation of field-replaceable pockets on main rotor blades will not affect blade balance, providing the trailing-edge tab of the field-replaceable pocket is trimmed to conform with the trailing-edge tab of the pocket removed.
- (2) The installation of field-replaceable pockets on main rotor blades will not significantly affect blade aerodynamic performance.
- (3) Based on the endurance test and the overspeed test, the field-replaceable pocket configured blade is adequate for flight tests.

It was recommended following the whirl test of the initial installation of field-replaceable pockets at Sikorsky Aircraft by Army maintenance personnel that:

- (1) A production weight requirement for the field-replaceable pocket be established to give a minimal increase in aircraft 1/rev vibration.

- (2) The trailing-edge tab area of the field-replaceable pocket be redesigned to match the production pocket trailing-edge tab to facilitate the use of the production tab bending tool.
- (3) The procedure for bonding the field-replaceable pocket to blade spar be improved to reduce bond voids and to establish an inspection procedure in the field to detect bond voids.
- (4) The effect of spanwise imbalance caused by field-replaceable pockets on aircraft 1/rev vibration be determined by flight test.

Items (2) and (3) above were subsequently incorporated; item (1) would be done in production, and item (4) was accomplished by flight test at Sikorsky and will be further evaluated by flight test of Army CH-54B helicopters in the field.

Purpose of Tests

The purpose of these tests was:

- (1) To determine the effects of the field-replaceable pocket installation on blade balance and performance.
- (2) To demonstrate the functional adequacy of the CH-54B main rotor blade with field-replaceable pockets (including the EA-9320 adhesive) prior to initial flight tests and field service evaluation by a 25-hour endurance whirl test and a brief overspeed test.

Background

The field-replaceable pockets used on the CH-54B blades for the whirl tests were installed by Army maintenance personnel to evaluate installation procedures and tooling. Fifteen replaceable pockets were installed at locations expected to have the greatest effect on blade balance and performance and locations which presented the most difficulty for installation. Table 7 shows the locations of the field-replaceable pockets installed on the test blades.

The tests consisted of the following areas of investigation:

- (1) Static spanwise balance
- (2) Dynamic and aerodynamic balance
- (3) Performance
- (4) Endurance, including start-stop cycling
- (5) Overspeed

TABLE 7. SPANWISE MOMENT SUMMARY

| Blade No. | Pockets Replaced | Spanwise Moment (in.-lb) | | |
|---------------|------------------|--|-------------------------------------|--------------------------|
| | | Prior to Installation of Field-Replaceable Pockets | Field-Replaceable Pockets Installed | Spanwise Moment (in.-lb) |
| 64M-2399-1097 | 9,10 | 78,497 | 78,560 | +63 |
| 64M-2451-1077 | 4,5,6 | 78,511 | 78,596 | +85 |
| 64M-2380-1095 | 9,16 | 78,498 | 78,570 | +72 |
| 64M-3211-1119 | 17,18,19 | 78,488 | 78,625 | +137 |
| 64M-3206-1109 | 2,3,4 | 78,505 | 78,648 | +143 |
| 64M-2496-1064 | 9,10 | 78,485 | 78,533 | +48 |

Notes:

- (1) Spanwise moments are about the centerline of rotation.
- (2) Pockets are numbered as shown in Table 10.
- (3) Two additional field-replaceable pockets were installed for flight test. See Figure 45, Configuration 4.

Blade Balance and Performance Conditions

The effect of field-replaceable pocket installation on the balance and performance of CH-54B main rotor blades, P/N 6415-20601, was determined by comparing the following measured blade parameters before and after the installation of the field-replaceable pockets:

- (1) Static spanwise moment
- (2) Pitching moment about the feathering axis as a function of blade angle
- (3) Tip-path-plane track as a function of blade angle
- (4) Lead-lag track as a function of blade angle

Static spanwise moment and tip-path-plane track are blade balance parameters which are dependent on the blade spanwise and chordwise mass distribution respectively. Lead-lag track is a blade balance parameter which is dependent on the airfoil contour (blade cross-sectional geometry). Pitching moment is a blade balance parameter which is dependent on both the chordwise mass distribution and the airfoil contour.

The static spanwise moment (about the centerline of rotation) for each of the six test blades was obtained using an ST1515-20001-T98 static balance scale. Blade pitching moment, tip-path-plane track, and lead-lag track were measured for each blade relative to a master blade by installing the test blades on the 3000-hp blade balance test stand shown in Figure D-1. All measurements were obtained relative to a Sikorsky master blade used for production blade balancing. This provided a reference blade that was unaltered throughout the test. To account for day-to-day measurement variability, data was obtained on different days.

Lead-lag track is a measure of the blade steady displacement in the plane of rotation (not the vibratory or hunting motion of the blade) relative to the master blade. The relative steady displacement is a measure of blade performance since it is a function of the blade drag characteristic. Therefore, any change in blade drag and hence any change in lead-lag track due to field-replaceable pocket installation can be related to a change in power (ΔH), as derived in Appendix D, page 142.

The lead-lag track measurements were obtained by use of an optional tracker, Chicago Aerial Model CA-470A. The tracker compares the test blade position at a given azimuthal position of the rotor head relative to two adjacent blades. This data is then converted to lead-lag displacement relative to a reference or master blade. The tracker was positioned at approximately 90% of blade radius.

Endurance Whirl Test Conditions

The six CH-54B main rotor blades with the field-replaceable pockets were installed on the 10,000-hp main rotor test stand (Figure D-2) and subjected to the CH-54 power and flapping spectra presented in Figure D-3 and D-4 respectively. In addition, the blades were subjected to an overspeed test and start-stop cycles as shown in Table 8.

Prior to installation of the test blades on the main rotor test stand, pocket-to-spar bond of each blade was inspected for voids. A "coin" test, which consists of tapping with a coin along the pocket-to-spar contact surface and aurally locating the bond voids, was used as a bond void inspection procedure. At the conclusion of the endurance whirl test, the "coin" test inspection of the test blades was repeated. A record of both bond void inspections was maintained to determine if any bond void propagation had occurred during the endurance whirl test.

Blade Balance and Performance Summary

The spanwise moment measurements before and after field-replaceable pocket installation are presented in Table 7. Blade pitching moment, lead-lag track, and tip-path-plane track data are graphically illustrated as a function of blade angle in Figures 37 through 42.

Endurance Whirl Test Summary

The endurance whirl test conditions and associated whirl test hours are summarized in Table 8.

Prior to the endurance whirl test, most of the test blades were found to contain pocket-to-spar bond voids, with pockets containing bond voids of up to 20% of the bond contact area. Since the purpose of the test was to evaluate pockets which might contain voids, these pockets were retained and tested. At the conclusion of the 25-hour endurance whirl test, no significant deterioration in pocket-to-spar bond was detected.

| TABLE 8. ENDURANCE WHIRL TEST SUMMARY | |
|---|--------------------|
| Test Condition | Duration |
| Thrust - 46,000 lb | 21.25 hr |
| Thrust - 53,000 lb | 3.75 hr |
| Overspeed - 231 rpm (125%NR) | 60 sec |
| Start-Stop Cycles* | 125 cycles |
| *Start-Stop cycle consisted of the following: | |
| Rotor Speed (rpm) | = 0 to 185 to 0 |
| Thrust (lb) | = 0 to 53,000 to 0 |
| Flapping (deg) | = 0 to 2 to 0 |

Blade Balance and Performance Results

The difference in blade static spanwise moment as a result of field-replaceable pocket installation (refer to Table 7) is due to the difference in weight between the production pocket and the field-replaceable pocket. The field-replaceable pocket is heavier than the production pocket by approximately 0.25 lb and 0.12 lb at an inboard and outboard blade station respectively. In addition, field-replaceable pocket weight varied as much as 0.030 lb. In order to result in a minimal increase in aircraft 1/rev vibration, the rotor imbalance due to increase in blade spanwise moment can be controlled by limiting the number of field-replaceable pockets installed on any one blade. The number of pockets allowed on a blade was later determined by analysis and flight test and is discussed under the flight test program.

Blade pitching moment, lead-lag track, and tip-path-plane track as a function of blade angle for each of the six test blades is presented in Figures 37 through 42. As can be seen, changes in pitching moment slope up to 8° due to the field-replaceable pockets range from no change (blade S/N 64M-2380-1095, Figure 37) to a change of approximately 170 in.-lb (blade S/N 64M-3206-110, Figure 41). Changes in pitching moment slope can be attributed to changes in weight and center of gravity location of the field-replaceable pockets.

Blade No. 64M-2380-1095

○ Production Blade

▽ Field-Replaceable Blade

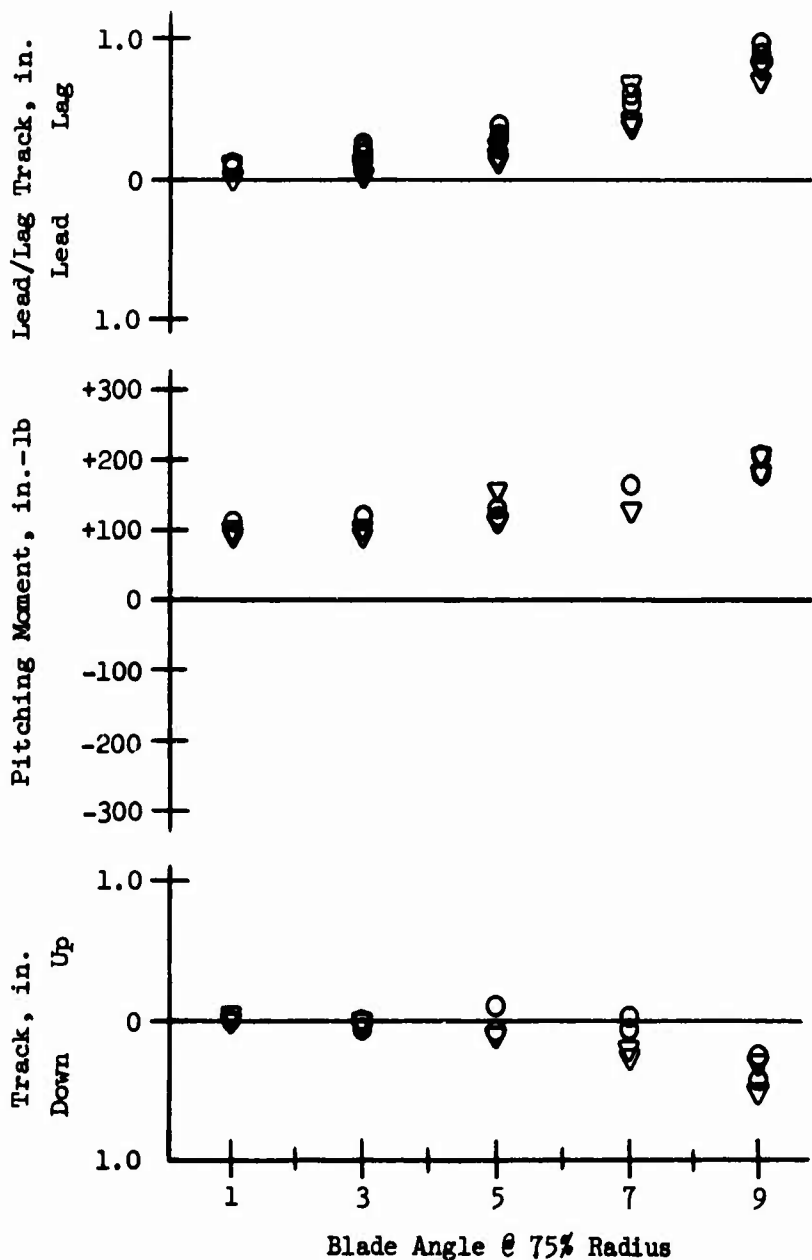

Figure 37. Blade Balance and Performance Summary.

Blade No. 64M-2451-1077

- Production Blade
- ▽ Field-Replaceable Blade
- ▼ Field-Replaceable Blade Before Tabbing

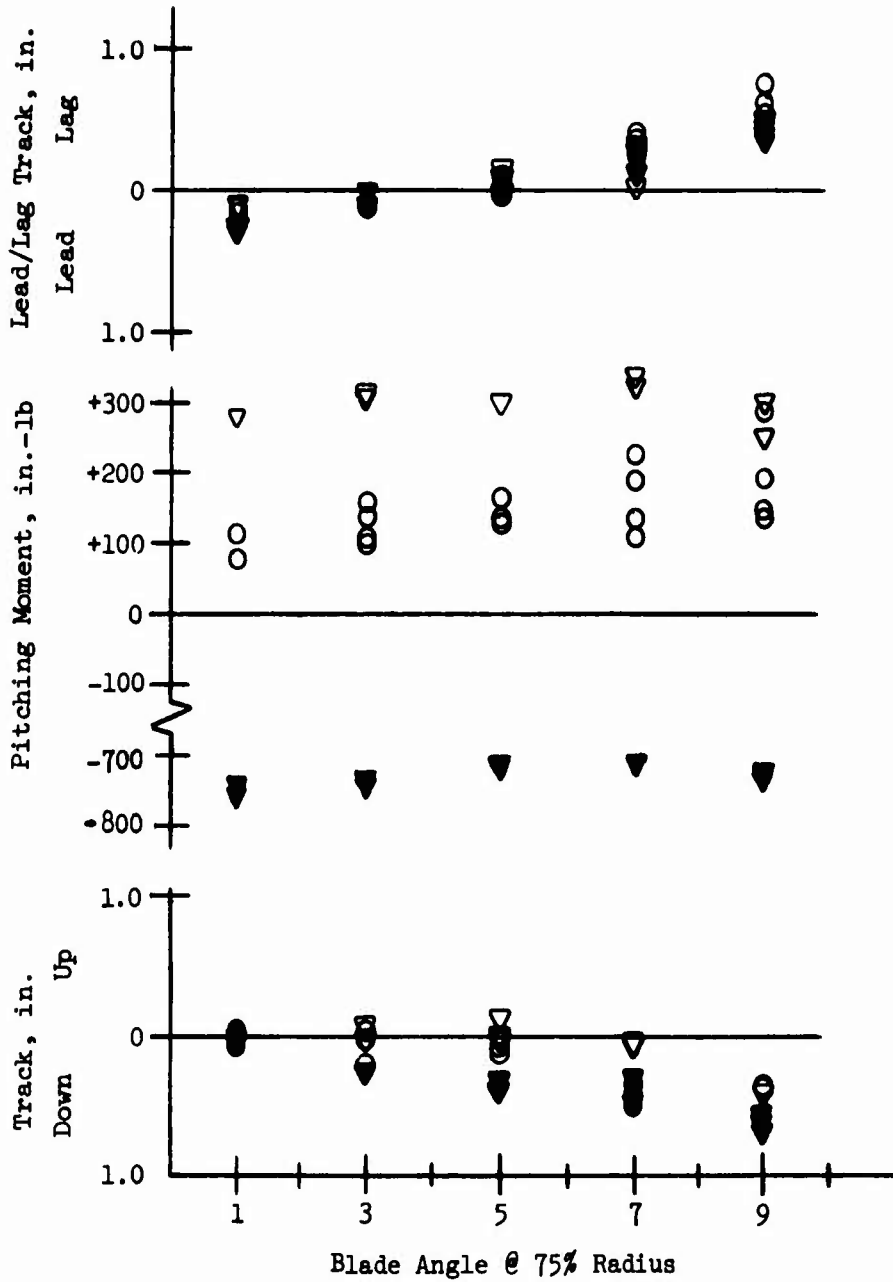

Figure 38. Blade Balance and Performance Summary.

Blade No. 64M-3211-1119

○ Production Blade

▽ Field-Replaceable Blade

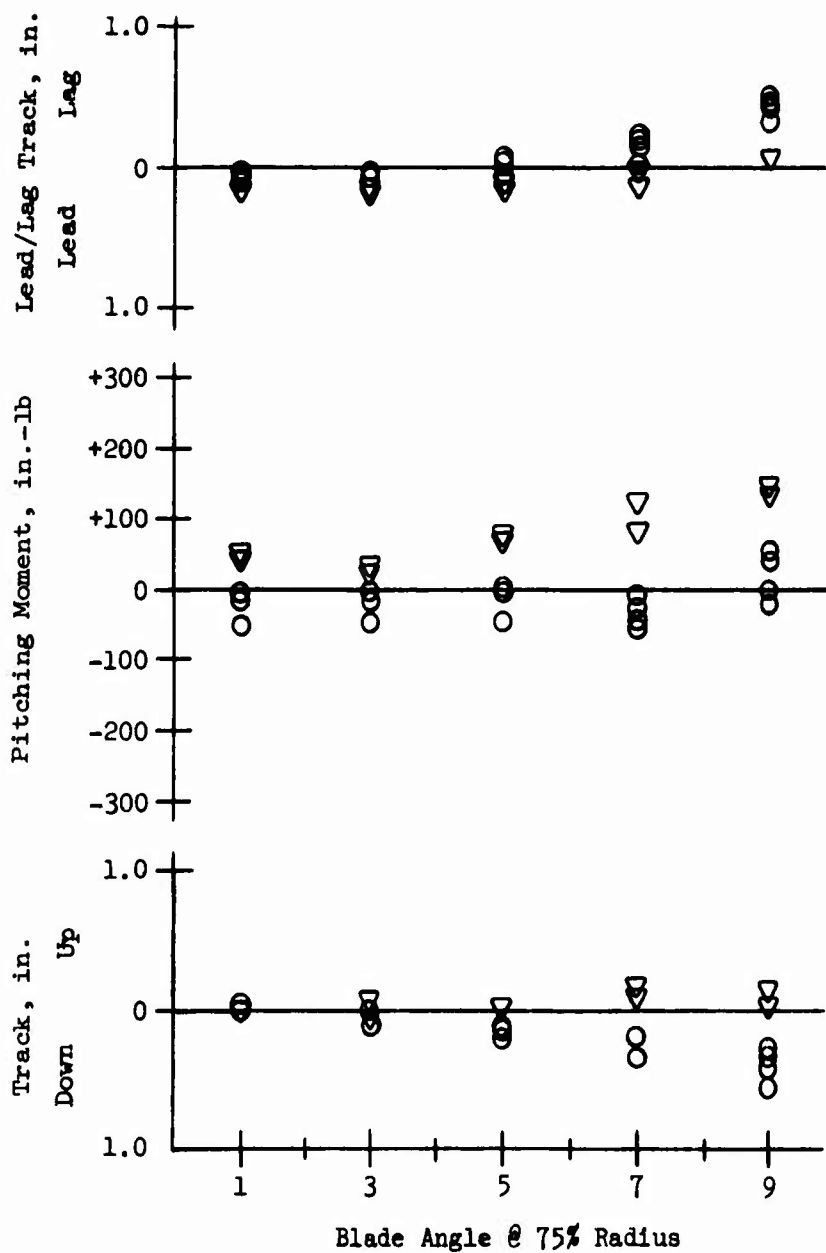

Figure 39. Blade Balance and Performance Summary.

Blade No. 64M-2496-1064

○ Production Blade

▽ Field-Replaceable Blade

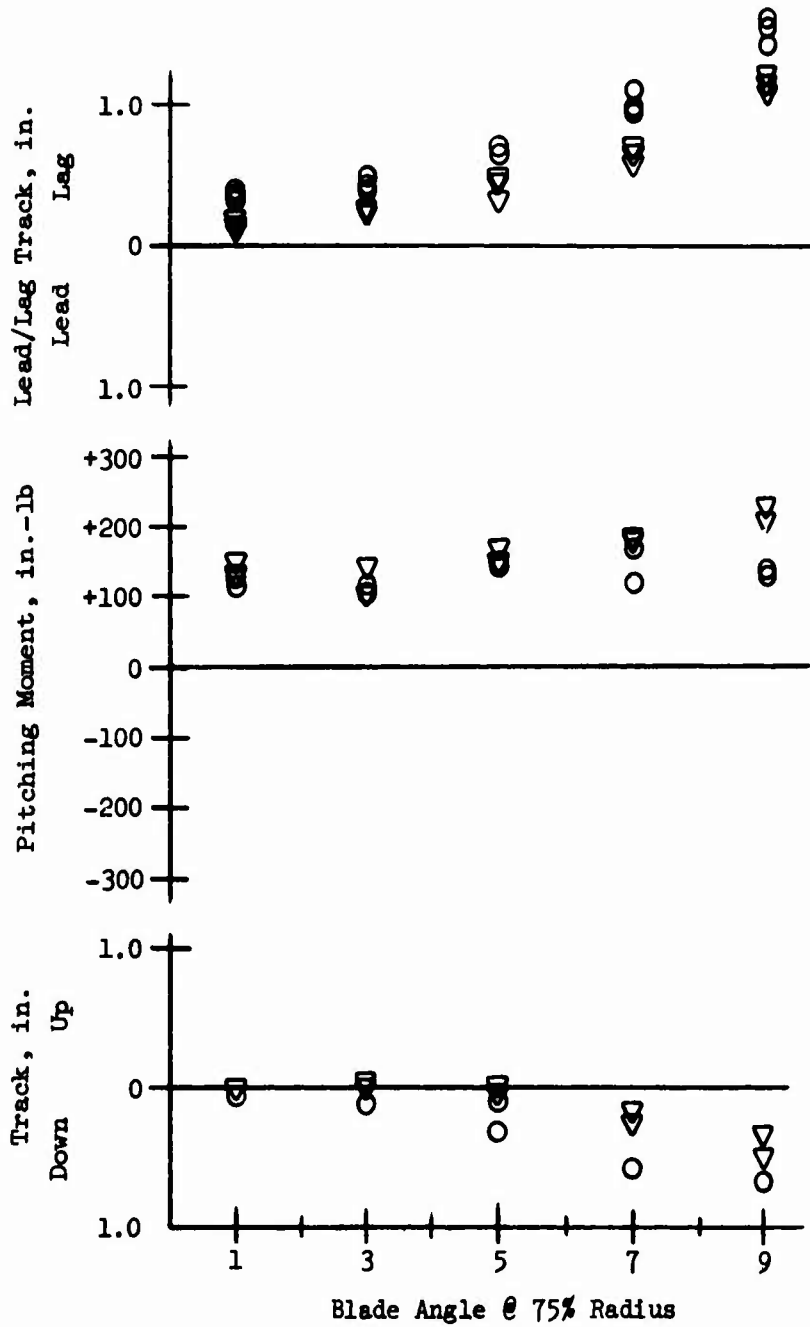

Figure 40. Blade Balance and Performance Summary.

Blade No. 64M-3206-1109

○ Production Blade

▽ Field-Replaceable Blade

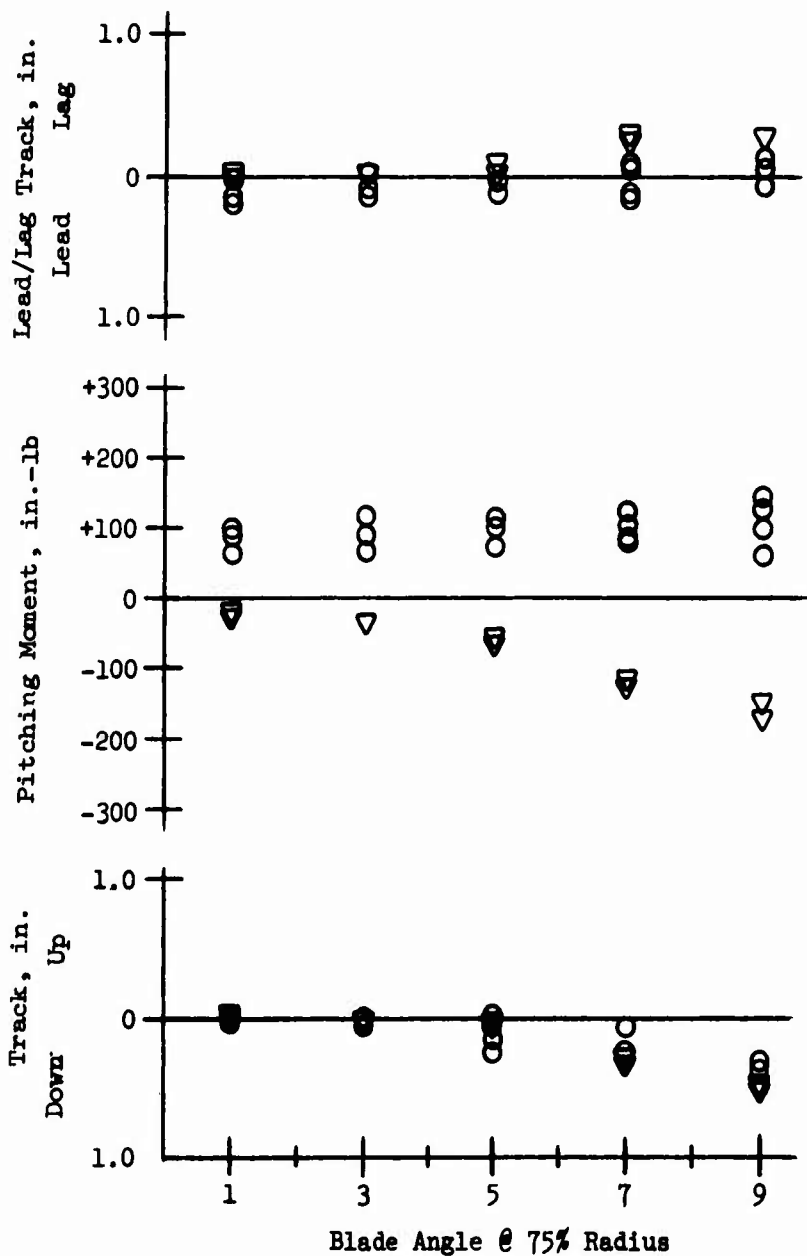

Figure 41. Blade Balance and Performance Summary.

Blade No. 64M-2399-1097

○ Production Blade

▽ Field-Replaceable Blade

▼ Field-Replaceable Blade Before Tabbing

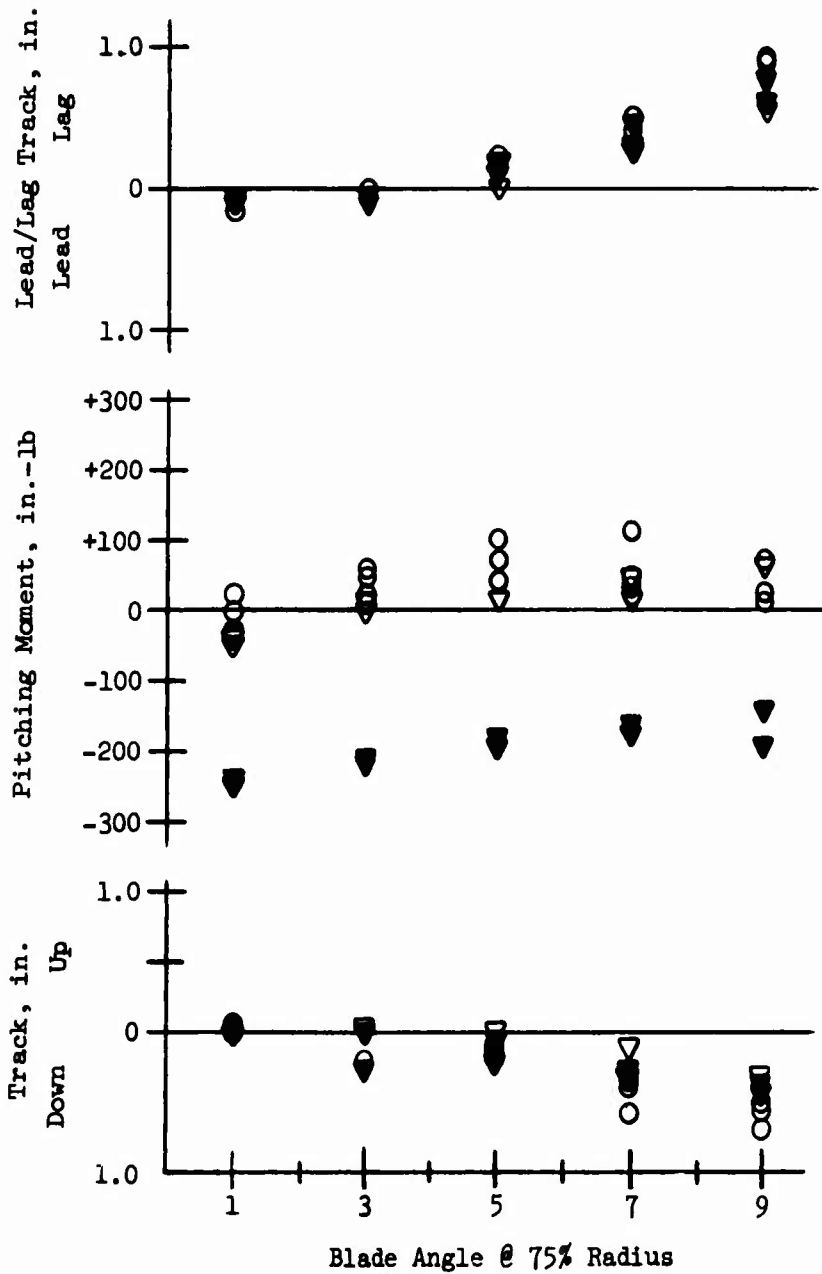

Figure 42. Blade Balance and Performance Summary.

The intercept of the pitching moment versus blade angle curves has changed and is attributed to a difference in trailing-edge trim tab between the production pocket and the field-replaceable pockets. The trailing-edge tab of the production pocket was not duplicated during the manufacture of the field-replaceable pocket (Figure 43), because the replaceable pocket initially consisted of a two-piece skin. (The final design, EWR 38633

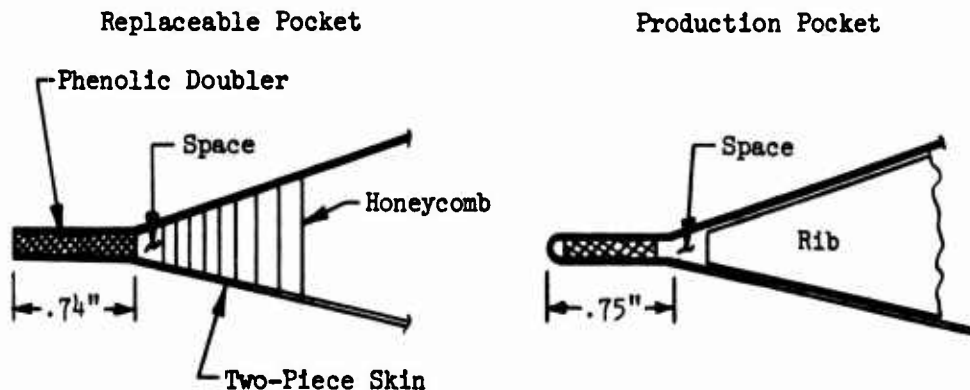

Figure 43. Trailing-Edge Tab.

Revision D, has a trailing-edge tab similar to the production pocket.)

The differences in trailing-edge tab width, specifically the lack of sufficient space between the phenolic tab doubler and honeycomb, prevented the use of the production trim-tabbing tool. A makeshift tool was utilized which permitted variations in the tab angle. Normally, aerodynamic pitching moment balance is obtained by trimming the desired length of tab while maintaining the tab angle constant. It is not feasible to preadjust the field-replaceable pocket tab since the length of trim tab required varies from blade to blade and is required only on outboard pockets.

The requirement for trimming the trailing-edge tab of the field-replaceable pocket to conform with the pocket removed is demonstrated by the pitching moment versus blade angle relationship (prior to tabbing) shown on Figures 38 and 42. As shown by the darkened triangular symbols, the pitching moment with the untabbed field-replaceable pockets is up to approximately 850 in.-lb more pitch reducing when compared to the pitching moment with production pockets. After duplicating the original trim-tab deflection on the field-replaceable pocket, the resultant blade pitching moment closely matched the pitching moment prior to pocket replacement.

As evidenced in Figures 37 through 42, the tip-path-plane track and lead-lag track versus blade angle relationships were not significantly affected by installation of field-replaceable pockets; therefore, no aerodynamic performance differences were detectable.

Endurance Whirl Test Results

The functional adequacy of the field-replaceable pocket configured blades was demonstrated by the 25-hour endurance whirl test and the overspeed whirl test. Although pocket-to-spar bond voids were initially detected, no significant propagation in the voids occurred during the whirl tests, and therefore confidence in the strength of the adhesive was further enhanced. Figure 44 shows blade No. 64M-2541-1077 (one of the blades subjected to whirl test) with #4, #5 and #6 field-replaceable pockets.



Figure 44. Installed Field-Replaceable Pockets.

FLIGHT TESTS

Summary

The purpose of the flight test program was to evaluate field-replaceable pockets installed on CH-54B main rotor blades at Sikorsky Aircraft to determine new pocket effect on blade stresses, flight vibrations and controllability when compared to a standard CH-54B aircraft configuration.

Flight Test Program

The flight test program was conducted in buildup stages as noted by the Flight Test Plan, Appendix E. Four configurations were flown; Configuration 1 utilized one blade containing three field-replaceable pockets, producing an out-of-balance of the rotor of 143 in.-lb (see Figure 45). Configuration 2 had three field-replaceable pocket blades all on one side of the rotor, causing a total imbalance of 365 in.-lb. Configuration 3 flew 6 field-replaceable pocket blades containing 15 field-replaceable pockets; the total out-of-balance was 182 in.-lb. Since no abnormal controllability or blade stresses developed, Configuration 4 was flown. It was essentially the same as Configuration 3 except that two more field-replaceable pockets were added (#4 and #5) on blade S/N 3206-1109, producing a total imbalance of 214 in.-lb.

Four blades were strain gaged for the test: blades S/N 3206-1109, S/N 3211-1119, S/N 2451-1077 and S/N 2380-1095. See Appendix E, Figure E-1. These were considered most critical (in the order noted) based on the increases in static spanwise moment as a result of installing field-replaceable pockets.

After conducting a maintenance check flight on CH-54B helicopter S/N 69-18462 to ensure that aircraft systems and instrumentation were operating satisfactorily, the flight test program was started. The various blade configurations of Figure 45 were installed, the instrumentation wiring was completed, and an electronic blade track was performed on the aircraft for each configuration prior to flight for all test flights; the aircraft was loaded to 47,000 pounds at a center of gravity of 328 inches and flown at a nominal sea-level altitude. Records were taken in various regimes of flight as shown in the flight test plan.

After each configuration was flown, the test data was scanned to ensure that it was sufficiently safe to continue with the next configuration. Since there was no evidence of abnormal blade stresses or vibrations, the flights continued through configurations 1, 2 and 3. For configuration 4, two more field-replaceable pockets were installed on blade S/N 3206-1109, making a total of five field pockets. A flight test was then conducted similar to the other configurations without adverse effects.

The stress data obtained from the four configurations flown was then compared to data recorded for the FAA Certification program to determine structural integrity and controllability of the CH-54B helicopter. This data is recorded in Reference 2. For the FAA Certification program, a

Configuration 1

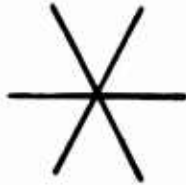

S/N 3206-1109 (#2, #3, #4)

Total Imbalance = +143 in.-lb

Configuration 2

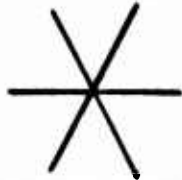

S/N 3206-1109 (#2, #3, #4)

S/N 3211-1119 (#17, #18, #19)

S/N 2451-1077 (#4, #5, #6)

Total Imbalance = +365 in.-lb

Configuration 3

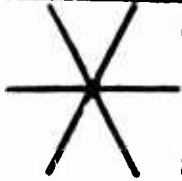

S/N 2496-1064
(#9, #10)

S/N 3206-1109 (#2, #3, #4)

S/N 2399-1097
(#9, #10)

S/N 3211-1119 (#17, #18, #19)

S/N 2380-1095 (#9, #16)

S/N 2451-1077 (#4, #5, #6)

Total Imbalance = +365 - 183 = +182 in.-lb

Configuration 4

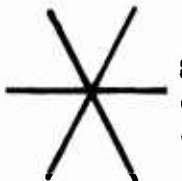

Same as Configuration 3
except with two more pockets
added to S/N 3206-1109 (#5, #6)

Total Imbalance = 397 - 183 = +214 in.-lb

NOTE: Numbers in parentheses are field-replaceable pockets and locations on the blade.

Figure 45. Configurations Flown - Looking Down From Top of Main Rotor.

takeoff gross weight of 48,000 pounds was used to allow increased test target weight of 47,000 pounds.

Flight Test Results

Comparison of the various parameters showed good correlation with the original flight data contained in Reference 2. These results indicated that no adverse effects were noted for any of the flights.

The plots of field-replaceable pocket blade stresses for all configurations tested are close to the stresses of standard blades from Reference 2. The stresses along the blade for stations L-1, NB-1, L-7 and BR6 are shown in Figures 46 through 53 for each configuration. The stresses are slightly higher for NB-1 for configurations 2 and 3 (Figures 48 and 50); however, they are still satisfactory because they are considerably below the design vibratory stress of ± 6500 psi. There is good correlation at the BR-6 station, the critical back corner radius, where combined flatwise and edge-wise stresses are developed. For configurations 3 and 4 (Figures 50 and 52) two BR-6 points appear low. L-7, the leading edge gage at 70% radius, shows stresses similar to standard blades, except for configuration 4, where they are lower. L-1 plots show that vibratory stresses are extremely low in this area and have no consequence on blade life.

The plots for pushrod and rotating scissors loads are shown in Figures 54 through 57. For the four configurations flown, the loads are less than, or similar to, existing data, which indicates no effects from modifying blade spanwise and chordwise moments by adding field-replaceable pockets.

Figures 58 and 59 are plots of the controllability of the aircraft. The longitudinal stick position curves shown in Figure 58 have positive slopes for all configurations and can be considered to have minor change from one configuration to another. The lateral stick is essentially the same for all four configurations. The curves of Figures 58 and 59 indicate that a pilot would not feel any difference in stick handling between flying a standard aircraft or an aircraft installed with blades modified with field-replaceable pockets. This was verified by comments made after each flight by the pilots assigned to the program. They all remarked that no differences in controllability or aircraft vibrations could be detected and that the aircraft flew in a normal manner.

Conclusions

It can be concluded that the flight test program has successfully demonstrated that there are no effects in blade stresses, vibrations, or controllability, and that these blades can be flown in the field.

Gross Weight 47,000 Lb C.G. 328 In.
FRP = Field Replaceable Pocket

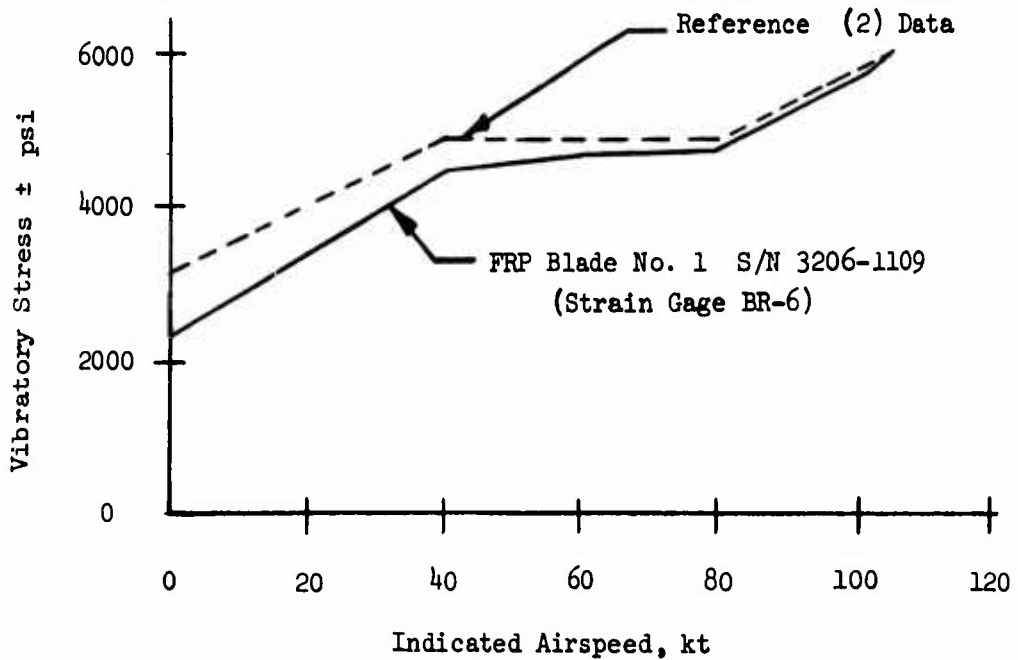
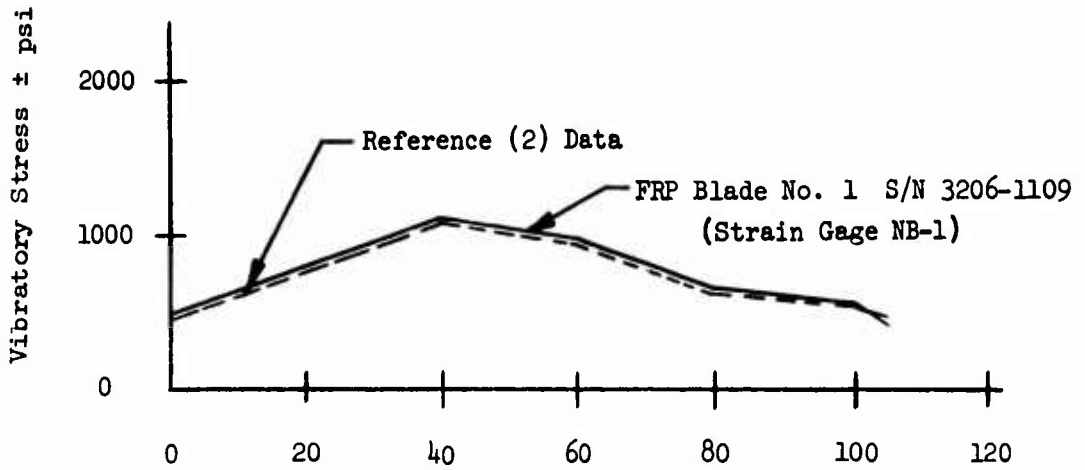

Figure 46. Configuration 1 - Blade Stresses vs Airspeed.

Gross Weight 47,000 Lb C.G. 328 In.
FRP = Field Replaceable Pocket

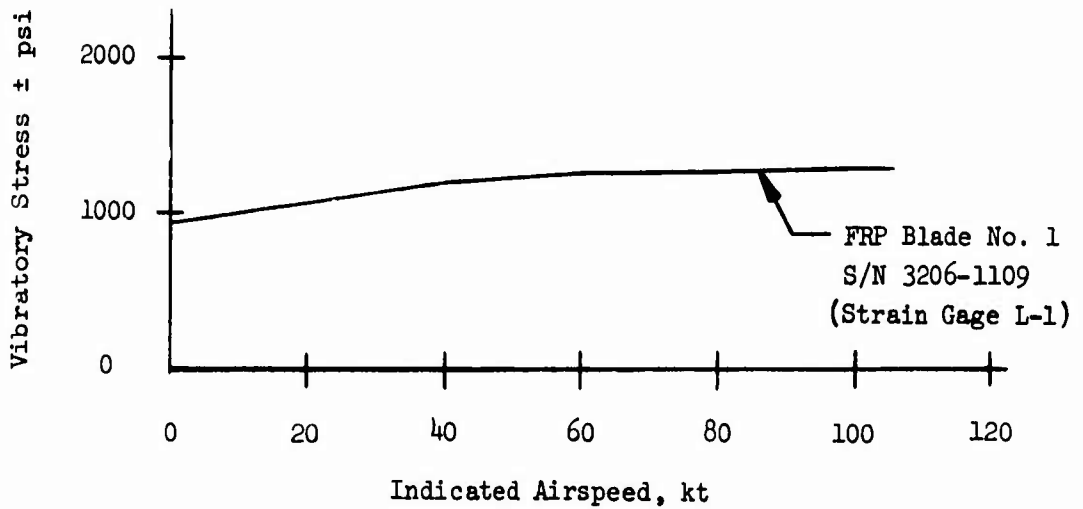
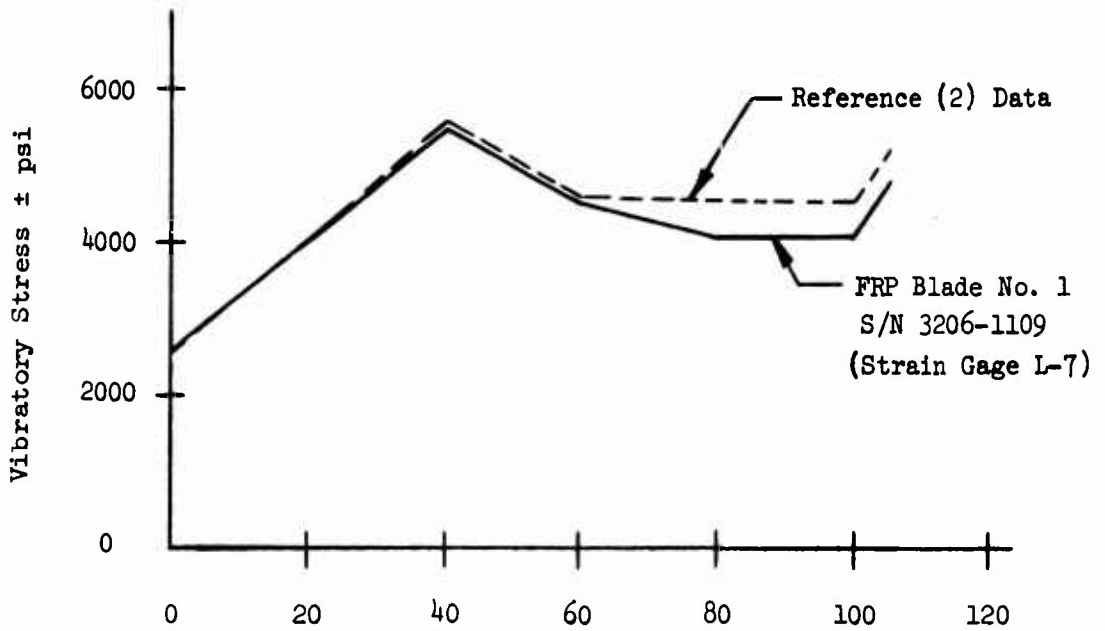

Figure 47, Configuration 1 - Blade Stresses vs Airspeed.

Gross Weight 47,000 Lb C.G. 328 In.
 FRP = Field Replaceable Pocket

FRP Blade No. 1 S/N 3206-1109- Δ
 FRP Blade No. 2 S/N 3211-1119- \circ
 FRP Blade No. 3 S/N 2451-1077- \square

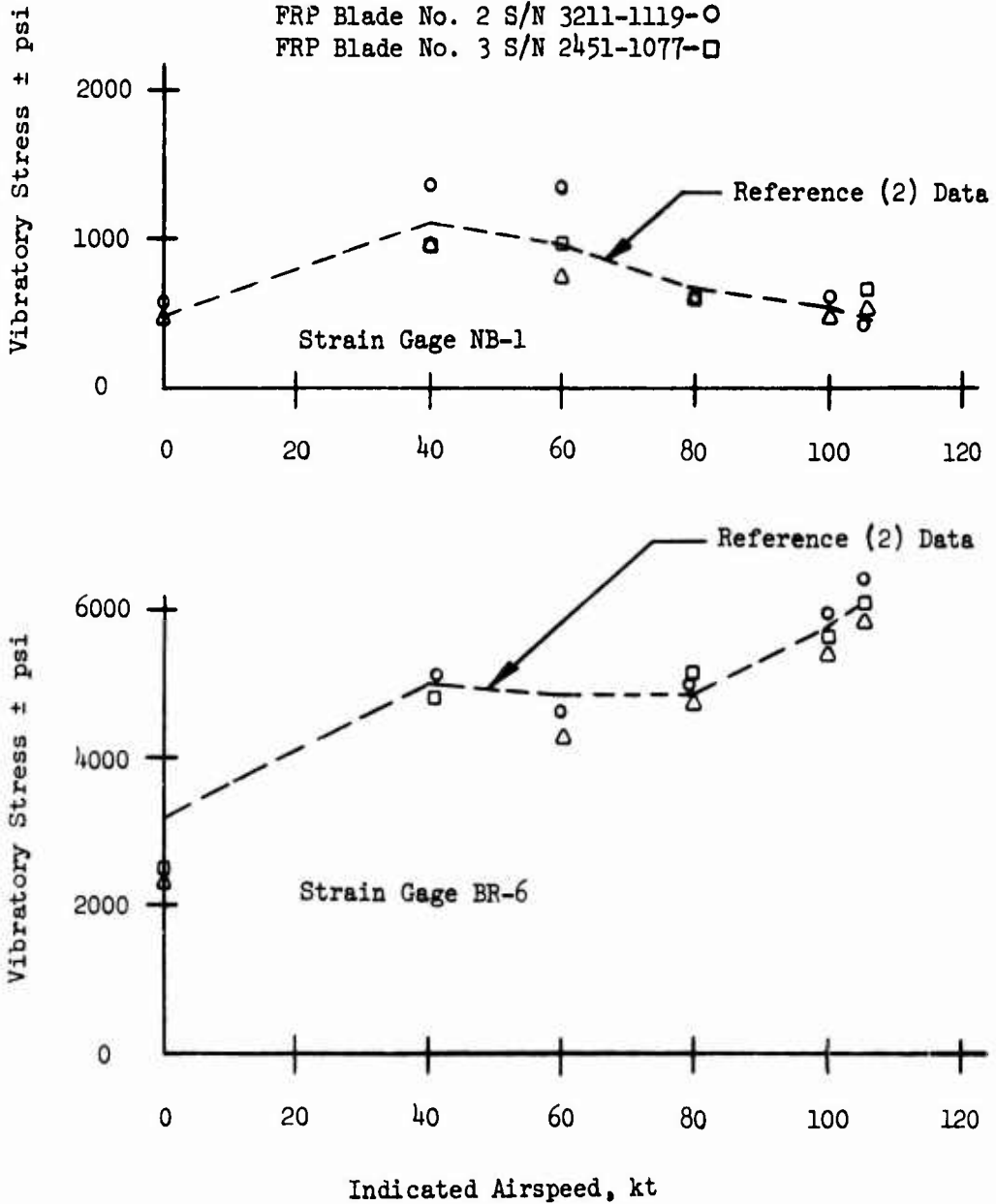

Figure 48. Configuration 2 - Blade Stresses vs Airspeed.

Gross Weight 47,000 Lb C.G. 328 In.

FRP = Field Replaceable Pocket

FRP Blade No. 1 S/N 3206-1109- Δ

FRP Blade No. 2 S/N 3211-1119- \circ

FRP Blade No. 3 S/N 2451-1077- \square

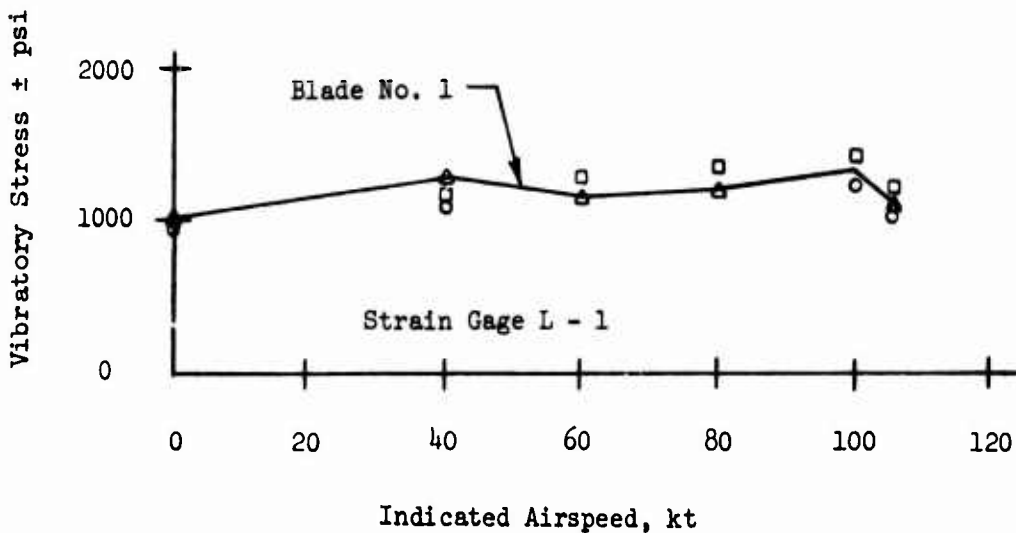
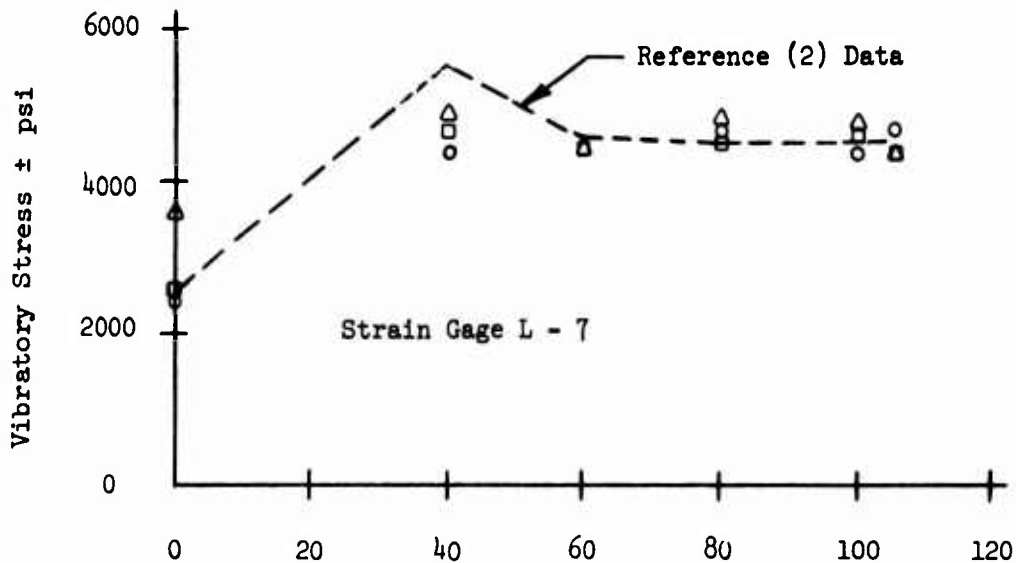

Figure 49. Configuration 2 - Blade Stresses vs Airspeed.

Gross Weight 47,000 Lb C.G. 328 In.
 FRP = Field Replaceable Pocket

FRP Blade No. 1 S/N 3206-1109 - Δ
 FRP Blade No. 2 S/N 3211-1119 - \circ
 FRP Blade No. 3 S/N 2151-1077 - \square
 FRP Blade No. 4 S/N 2110-1095 - $+$

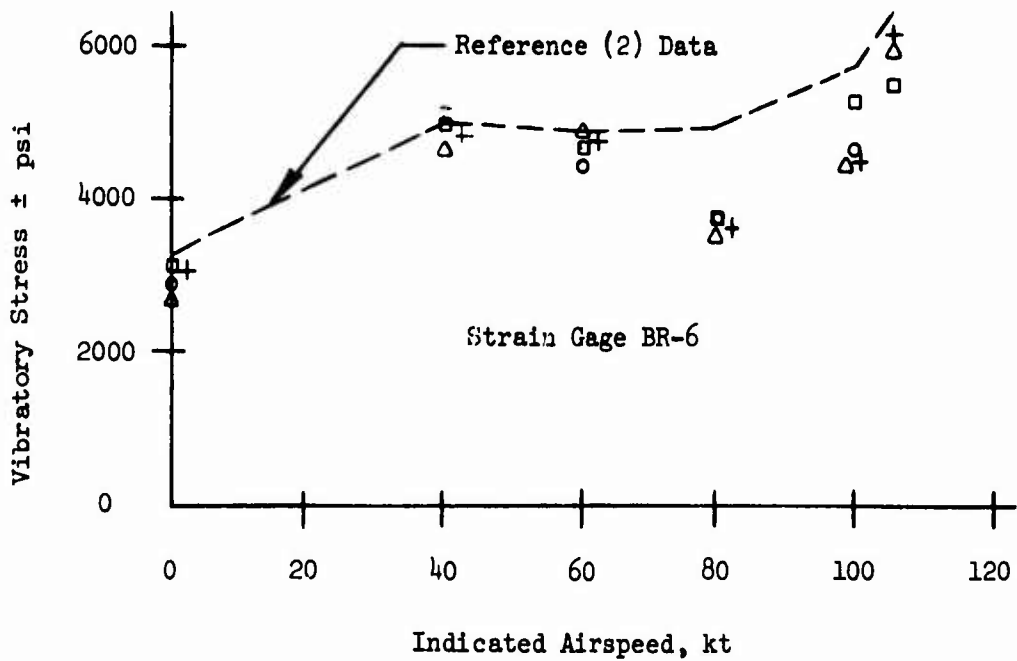
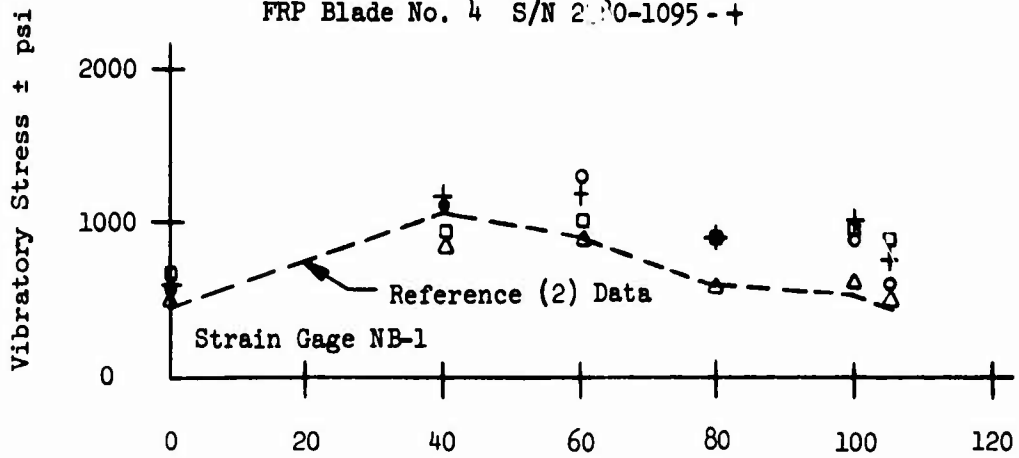

Figure 50. Configuration 3 - Blade Stresses vs Airspeed.

Gross Weight 47,000 Lb C.G. 328 In.

FRP = Field Replaceable Pocket

FRP Blade No. 1 S/N 3206-1109 - Δ

FRP Blade No. 2 S/N 3211-1119 - \circ

FRP Blade No. 3 S/N 2451-1077 - \square

FRP Blade No. 4 S/N 2380-1095 - $+$

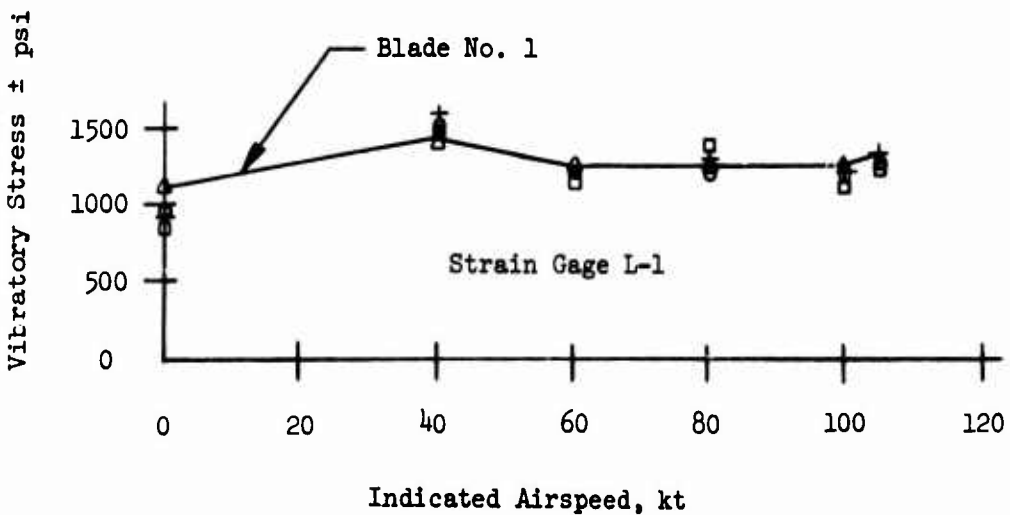
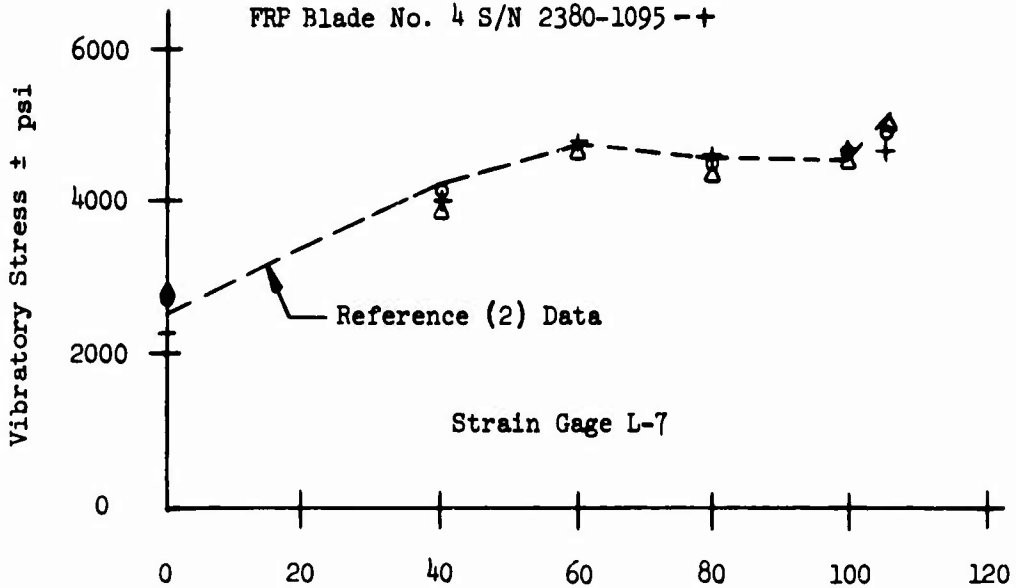

Figure 51. Configuration 3 - Blade Stresses vs Airspeed.

Gross Weight 47,000 Lb C.G. 328 In.
 FRP = Field Replaceable Pocket

FRP Blade No. 1 S/N 3206-1109 — Δ
 FRP Blade No. 2 S/N 3211-1119 — \circ
 FRP Blade No. 3 S/N 2451-1077 — \square
 FRP Blade No. 4 S/N 2380-1095 — $+$

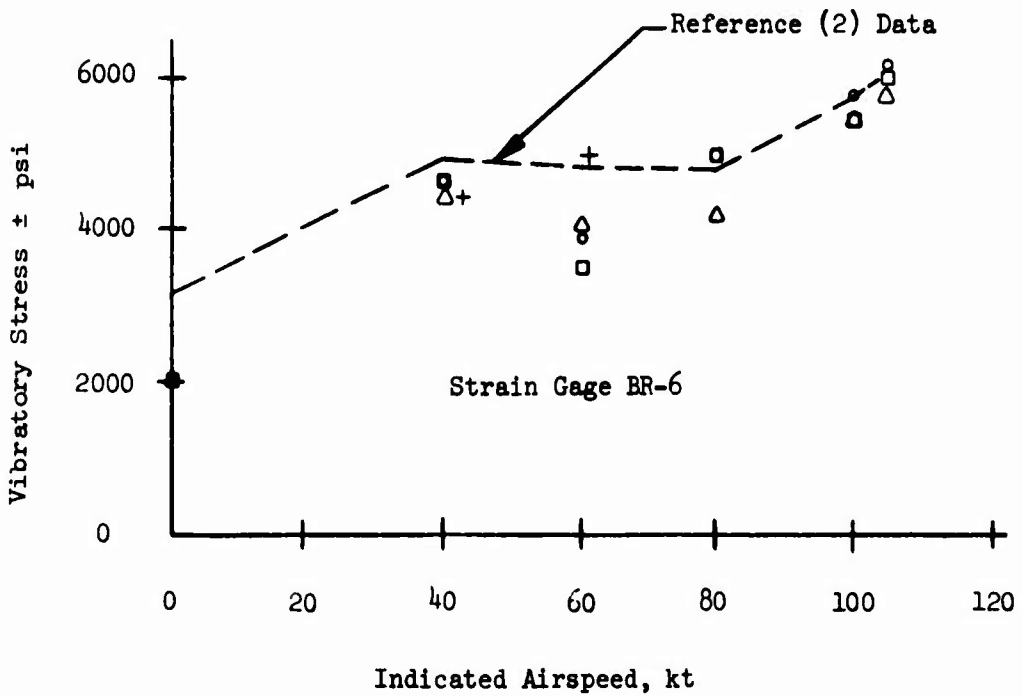
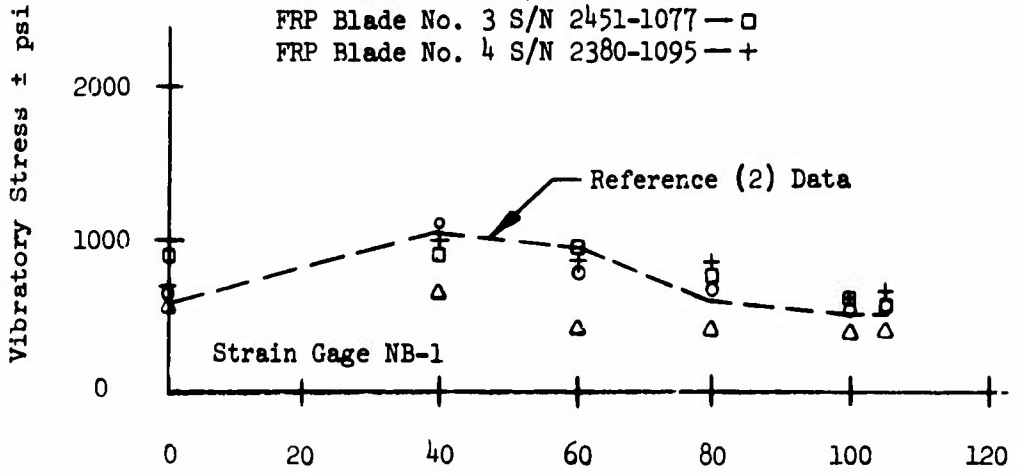

Figure 52. Configuration 4 - Blade Stresses vs Airspeed.

Gross Weight 47,000 Lb C.G. 328 In.
 FRP = Field Replaceable Pocket

FRP Blade No. 1 S/N 3206-1109 — Δ
 FRP Blade No. 2 S/N 3211-1119 — \circ
 FRP Blade No. 3 S/N 2451-1077 — \square
 FRP Blade No. 4 S/N 2380-1095 — $+$

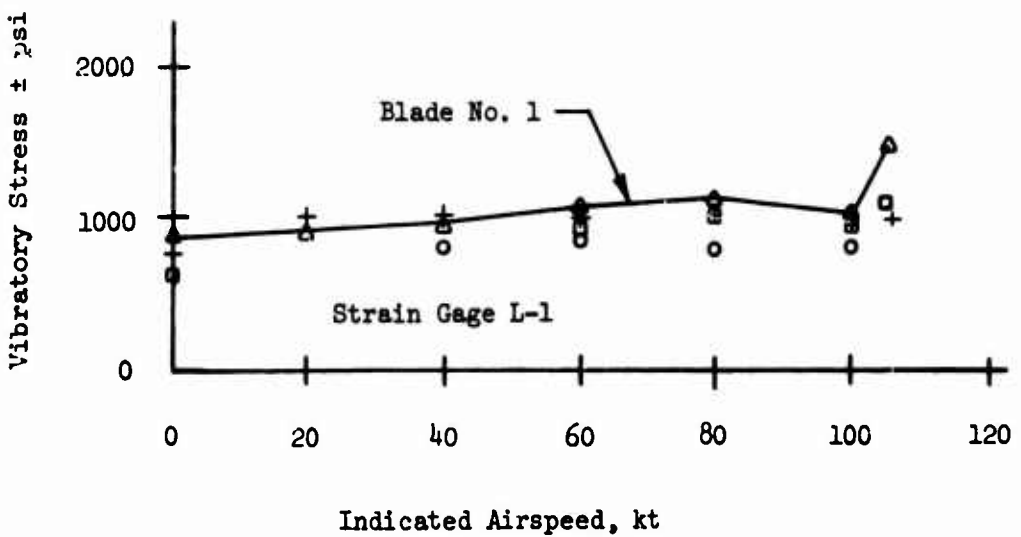
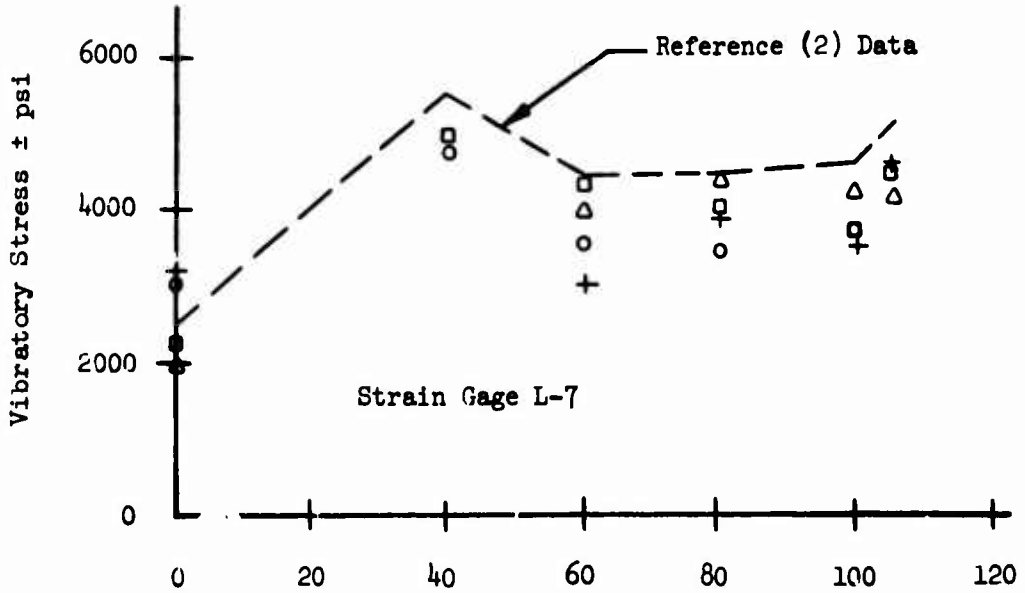
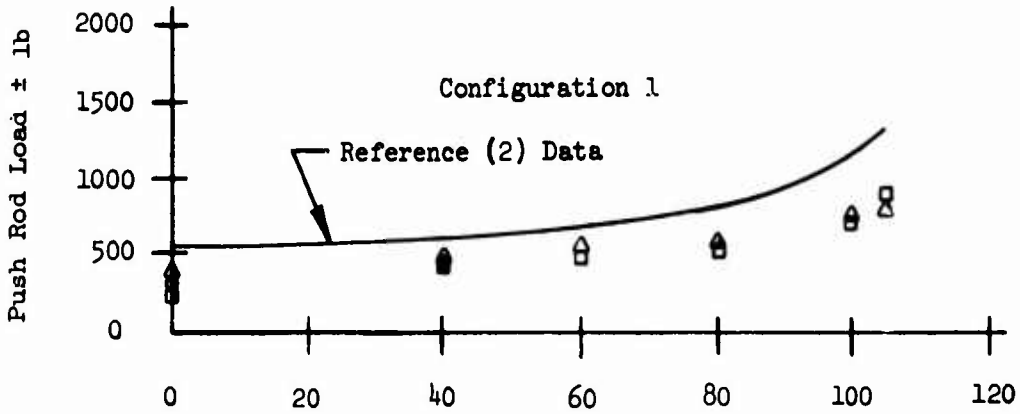

Figure 53. Configuration 4 - Blade Stresses vs Airspeed.

Gross Weight 47,000 Lb C.G. 328 In.
 FRP = Field Replaceable Pocket

FRP Blade No. 1 S/N 3206-1109 — Δ
 2 Standard Blades — \circ, \square



FRP Blade No. 1 S/N 3206-1109 — Δ
 FRP Blade No. 2 S/N 3211-1119 — \circ
 FRP Blade No. 3 S/N 2380-1095 — \square

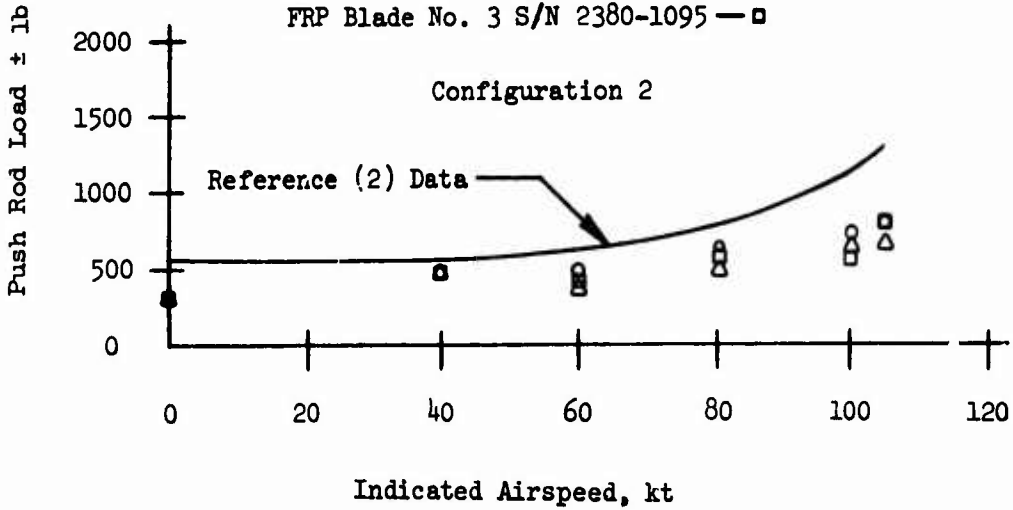

Figure 54. Configurations 1 and 2 - Push Rod Loads vs Airspeed.

Gross Weight 47,000 Lb C.G. 328 In.
 FRP = Field Replaceable Pocket

FRP Blade No. 1 S/N 3206-1109 —△
 FRP Blade No. 2 S/N 3211-1119 —○
 FRP Blade No. 3 S/N 2380-1095 —□

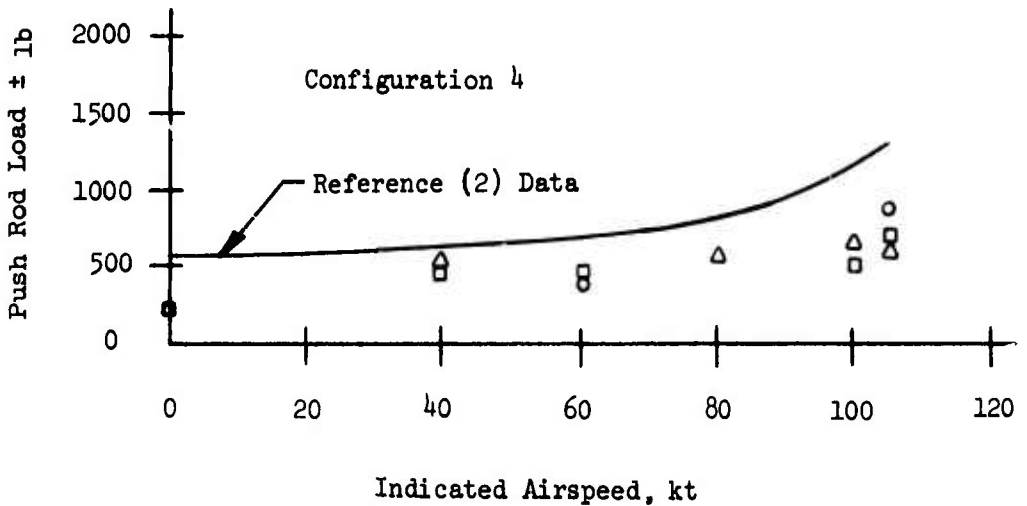
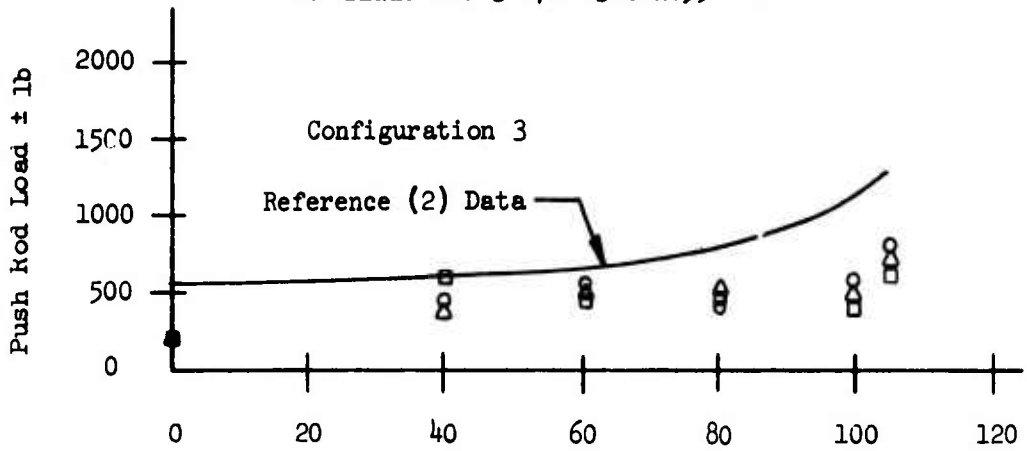

Figure 55. Configurations 3 and 4 - Push Rod Loads vs Airspeed.

Gross Weight 47,000 Lb

C.G. 328 In.

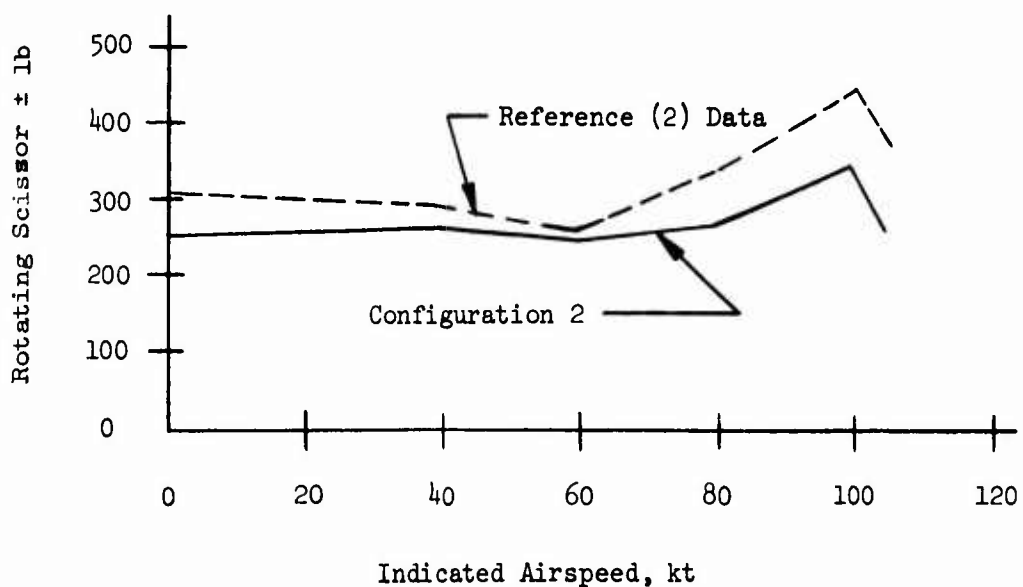
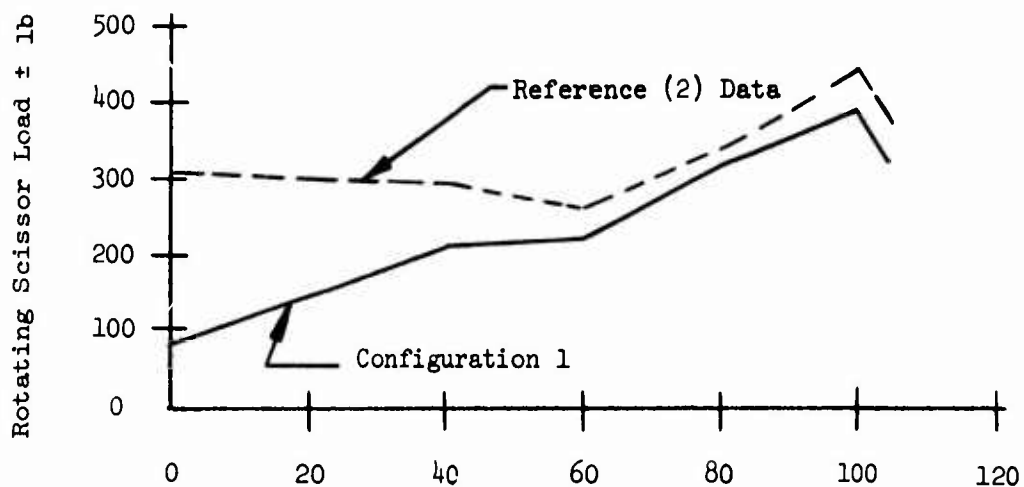

Figure 56. Configurations 1 and 2 - Rotating Scissors Load vs. Airspeed.

Gross Weight 47,000 Lb

C.G. 328 In.

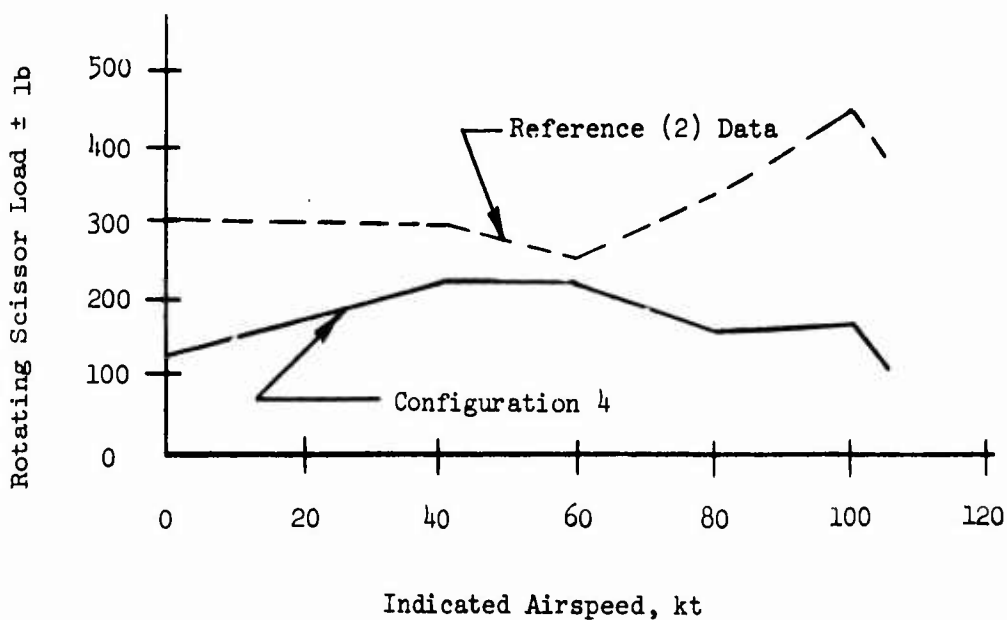
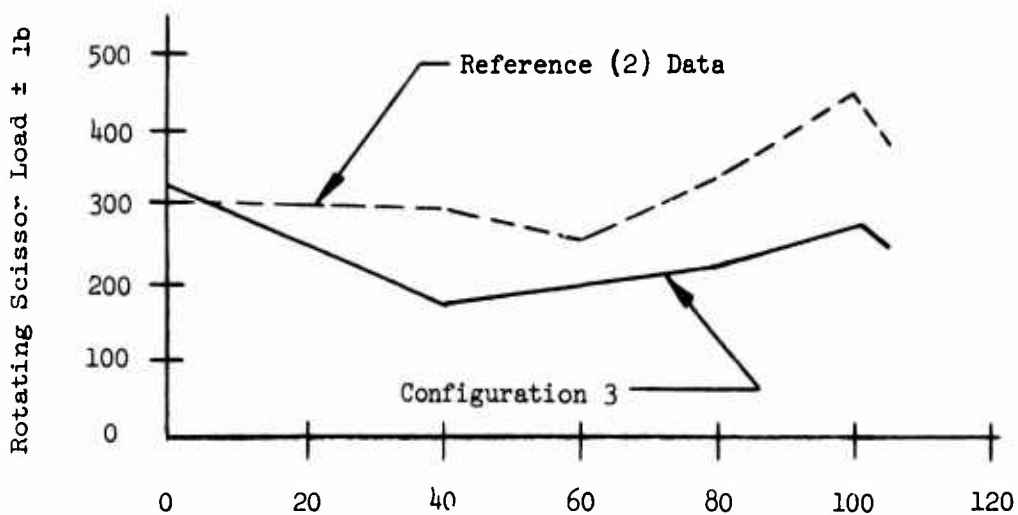

Figure 57. Configurations 3 and 4 - Rotating Scissors Load vs Airspeed.

Gross Weight 47,000 Lb

C.G. 328 In.

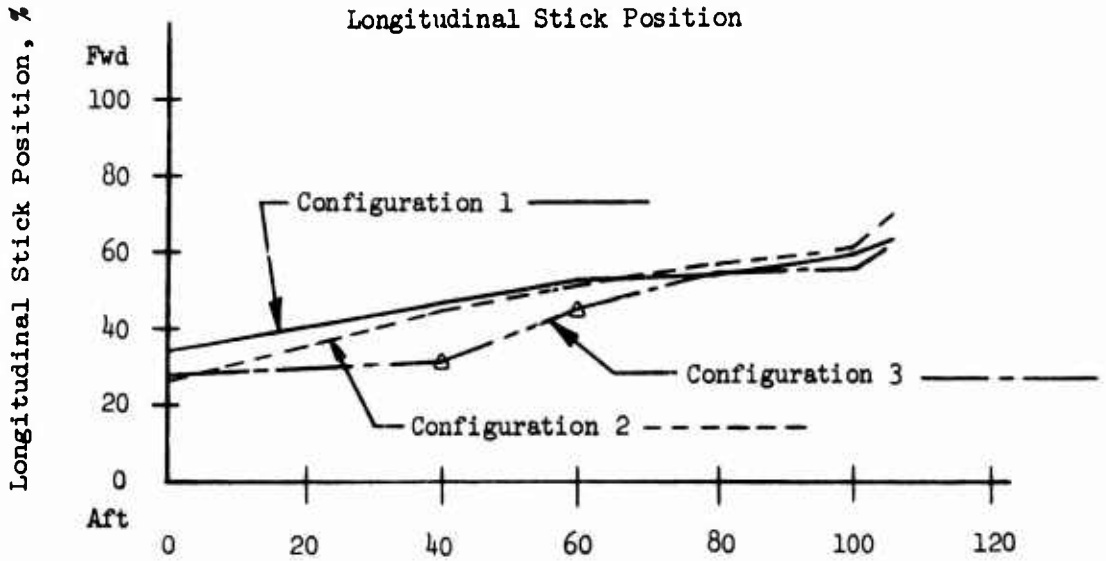

Figure 58. Longitudinal Stick Position vs Airspeed.

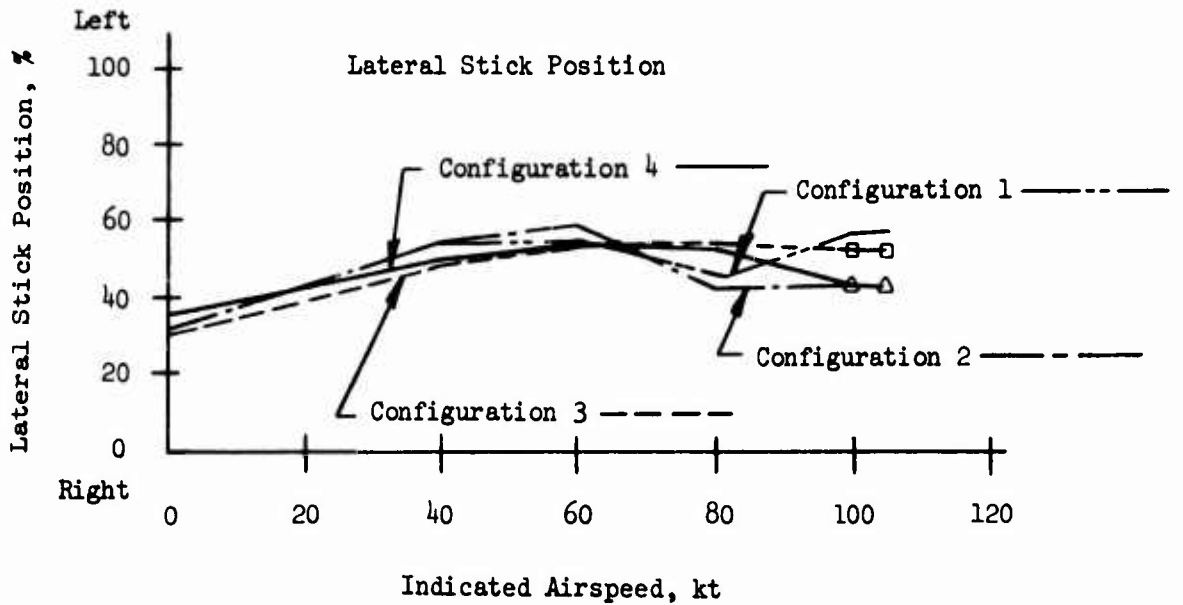

Figure 59. Lateral Stick Position vs Airspeed.

Multiple Pocket Replacement

An investigation was performed to determine the maximum number of field-replaceable pockets installable on one blade without affecting blade performance. The analysis was based mainly on results of whirl and flight tests.

The whirl test plots of Figures 37 through 42 showed that there were no appreciable changes in track (lead/lag or out-of-plane) and pitching moments for the six blades installed with field-replaceable pockets. This indicated there would be no effect in aerodynamic performance.

The flight test showed that blade stresses and aircraft vibrations were also similar to a standard CH-54B flight. There was no effect from rotor out-of-balance during any one of the four configurations flown. Configuration 1 had one field-replaceable pocket blade (Figure 45), which produced a spanwise moment imbalance of 143 in.-lb. Configuration 2 had three field-replaceable pocket blades all on one side of the rotor, producing a total out-of-balance of 365 in.-lb. Configurations 3 and 4 produced rotor out-of-balance of 182 and 214 in.-lb respectively. Configuration 4 had one blade installed with five field-replaceable pockets, which produced by itself an out-of-balance of 175 in.-lb. These same five pockets replaced in the field could possibly have resulted in an out-of-balance as high as 210 in.-lb, depending upon the person installing the pocket. This higher figure is based on analysis and assumes the worse case where the repairman uses all the adhesive in the container and removes a minimum of the old adhesive. This 210 in.-lb out-of-balance is acceptable and will be used as the maximum imbalance allowed. Table 9 is a tabulation of the spanwise out-of-balance as a maximum, anywhere from four pockets (#2, #3, #4 and #17) up to twelve pockets (#6 through #16 plus #27) could be replaced in the field.

| TABLE 9. FIELD-REPLACEABLE POCKET SPANWISE MOMENT CHANGE | | | | | | | |
|--|--------------|-----------------|--------------|-----------------|--------------|-----------------|--------------|
| Pocket Position | Mom (in.-lb) | Pocket Position | Mom (in.-lb) | Pocket Position | Mom (in.-lb) | Pocket Position | Mom (in.-lb) |
| #2 | 53 | #9 | 2 | #16 | 21 | #23 | 35 |
| #3 | 51 | #10 | 0 | #17 | 52 | #24 | 32 |
| #4 | 49 | #11 | 0 | #18 | 49 | #25 | 29 |
| #5 | 35 | #12 | 26 | #19 | 46 | #26 | 27 |
| #6 | 22 | #13 | 25 | #20 | 43 | #27 | 24 |
| #7 | 21 | #14 | 23 | #21 | 41 | | |
| #8 | 20 | #15 | 22 | #22 | 38 | | |

FIELD INSTALLATION

INSTALLATION OF FIELD-REPLACEABLE POCKETS

The installation was a two-part program in which Army maintenance personnel installed a total of 35 field-replaceable pockets on CH-54B main rotor blades at Sikorsky Aircraft and in the field. The first part, conducted at the Sikorsky Aircraft plant, was more for experimentation to evaluate the field-replaceable pocket kit, the bonding fixture tool, the instruction manual, and the time required to make a repair. The second part consisted of actual field operations where pockets were installed on main rotor blades at Fort Wainwright, Alaska, and Fort Eustis, Virginia.

SIKORSKY INSTALLATION

Pockets were installed on CH-54 main rotor blades by Army maintenance personnel (MOS 67 x 20, CH-54 helicopter repairman). Fifteen pockets were installed on six different blades at the Sikorsky plant, using the field repair manual and kit shown in Figure 19. Table 10 shows the blade serial numbers and the pockets replaced. Pocket replacements along the blade were selected for the following reasons:

- a) Pockets that produced the highest out-of-tolerance of track, pitching and spanwise moments.
- b) Pockets that required backwall spacers (to ascertain problems to be encountered in selection of proper spacer and installation).
- c) Pocket subjected to highest loads.

All replaceable pockets, including those installed at Sikorsky, were furnished in field kit boxes to simulate field conditions. All parts required to repair a pocket were obtained from the kits. Repair was done by both one-man and two-man teams. Field-replaceable pockets were installed merely by following the instruction manual provided with each kit. The members of the team had a minimum of problems in following instructions, either in removing a production pocket or in installing a field-replaceable pocket. However, some changes both in the written text and in the illustrations were necessary to further refine the teardown/installation procedure prior to installation at the Army bases.

To assess the repair, the Army maintenance men at Sikorsky were timed to determine the time required for each of the following operations:

| <u>Step</u> | <u>Operation</u> |
|-------------|--|
| 1. | Remove damaged pocket from spar. |
| 3. | Remove loose adhesive and clean spar, pocket and spacer (if required). |
| 3. | Mix adhesive. |

TABLE 10. FIELD-REPLACEABLE POCKETS INSTALLED ON
CH-54B MAIN ROTOR BLADES

| Experimental Blade Serial No. | Installation Site/Pocket Numbers | | |
|----------------------------------|----------------------------------|-----------------------------|-------------------------|
| | Sikorsky A/C Feb 1974 | Fort Wainwright Oct 1974 | Fort Eustis Nov 1974 |
| 64-M-3034-1125 | | - | #2, #3, #4 |
| 64-M-3206-1109 | #2, #3, #4, #5, #6 | - | #3(a), #4(a), #15 |
| 64-M-2399-1097 | #9, #10 | - | #10(a) |
| 64-M-2451-1077 | #4, #5, #6 | - | #6(a), #9, #15 |
| 64-M-2481-1068 | | #5, #6 | - |
| 64-M-2496-1064 | #9, #10 | #2, #4, #5 | - |
| 64-M-3211-1119 | #17, #18, #19 | #15 | - |
| 64-M-2380-1095 | #9, #16 | #2, #15 | - |
| 64-M-2440-1078 | | #2, #3 | - |

(a) These are replacements of field-replaceable pockets

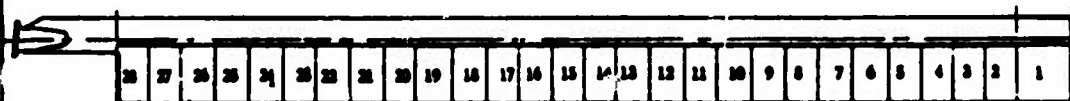

4. Apply adhesive and install pocket with bonding fixture.
5. The sum of these four operations gave the total repair time.

The times required to make a complete repair ranged from 37 minutes to 1- $\frac{1}{2}$ hours. The repairman doing the repair in 37 minutes performed steps 1 through 4 above in 8, 14, 5 and 10 minutes respectively. The repairman requiring 1- $\frac{1}{2}$ hours performed steps 1 through 4 in 30, 30, 15, and 15 minutes respectively. The average time for the four repairmen was 1 hour. It was noted during this evaluation that the adhesive was becoming tacky and viscous for those repairmen requiring more time for steps 3 and 4.

After all blades had been repaired and the adhesive on the new pockets had cured, the field-replaceable pockets were inspected by quality control. By coin tapping, bond voids were found in 12 of the 15 pockets installed. The bond voids in 10 of these pockets were acceptable for whirl and 5 hours of flight. The remaining 2 pockets not acceptable were removed to determine cause of separation. Examination showed that although the adhesive had been properly applied to all bonding surfaces, there were voids between the layers of adhesive, indicating that the pocket skins were not sufficiently pressed against the sides of the spar. Since the observation had already been made during assembly that the adhesive became tacky if steps 3 and 4 took $\frac{1}{2}$ hour or more, it was concluded that the adhesive was not fluid enough to flow under the bonding fixture pressure.

The blades containing the two unacceptable pockets were repaired with replaceable pockets by a Sikorsky repairman utilizing the same instruction procedures used by the Army team. The times of steps 3 and 4 for each pocket were noted to total 15 minutes. After the pockets were cured, inspectors performed the coin-tapping operation and did not detect any voids. Prior information on installation of pockets on proof load and fatigue specimens indicated that up to 25 minutes could be allowed before any noticeable voids result. As a safety factor, however, it was recommended that a pot life of 20 minutes be inserted into the instruction manual. That is, the time from the start of adhesive mixing to the time the bonding fixture is placed in position should be a maximum of 20 minutes instead of 30 minutes, as specified in the instruction manual.

This adhesive mixing was accomplished by removing the two-part contents of the adhesive from the package instead of mixing the two components prior to removal from the package. A corner is snipped from one end of the kneading package. Using a spatula provided with the package, the adhesive or catalyst is squeegeed into a plastic cup. The package is reversed and a corner is snipped from the other end, and the squeegeeing operation is repeated. The adhesive and catalyst are then mixed in the cup with the spatula. The total squeegeeing and mixing time is 2 minutes. This should allow sufficient time in the remaining 18 minutes to apply the adhesive to all components and to install the bonding fixture.

Even though the field-replaceable pockets had some bond voids in most pockets installed, the blades were whirled for performance and endurance runs for approximately 50 hours. Examination by inspection found no further

bond separation after whirling, indicating the excellent peel strength of the adhesive.

It was also determined during this evaluation that a tabbing tool would be required for pockets replaced in the trim-tab area. This is a simple tool that can be fabricated for use in the field.

FIELD INSTALLATION

Twenty replaceable pockets were installed in the field at Fort Wainwright and Fort Eustis as noted by Table 10. Results of field evaluation of these blades are discussed under Field Flight Evaluation.

It was noted during the field installation that some additional improvements could be made to provide better pocket-to-spar bonding by making the following changes/additions:

1. Remove the strips of masking tape applied to the pocket leading edge and adjacent sides after sanding, cleaning with alcohol, and adhesive application but prior to placing pocket on blade. Also, apply two layers of masking tape to leading outside edge of new pocket before installing new pocket on blade. These changes would provide better contact between bonding fixture and pocket flange during bonding operation.
2. Install backup plates to present side tubes of bonding fixture or replace with larger tubes to obtain greater force in bungee cords to increase pressure on bonding area. Also, provide softer durometer silicone rubber pads on side tubes to better conform pads to contour of the blade, thus obtaining more uniform distribution of pressure. Finally, provide straps around leading edge of the blade to secure to both side tubes to prevent movement of tubes during curing operation.
3. Provide 60-gram packs of adhesive instead of 50-gram packs to prevent "skipping" and stretching" of adhesive when backwall spacers are required. Also, change the present adhesive to a two-package system, with the adhesive in a metal container and the catalyst in a small vial. Mixing would be in the metal container, eliminating the possibility of spillage, eliminating leakage between the dam of the present adhesive, and removing the requirement of the plastic cup (a separate mixing container).

These minor changes should enhance bonding procedure and eliminate some of the bond voids encountered.

FIELD FLIGHT EVALUATION

FLIGHT RESULTS

A 6-month flight evaluation of the field-replaceable pockets was conducted under Contract DAAJ02-73-C-0076. The flight evaluation was part of a development program being conducted to provide rotor blade pockets which could be replaced at field level by Army maintenance personnel. It consisted of field installation by Army personnel of 35 pockets on 9 CH-54B rotor blades. Fifteen pockets were installed at the Sikorsky plant and ten pockets were installed at each location of Fort Eustis, Virginia and Fort Wainwright, Alaska.

A total pocket time of approximately 1360 hours was accumulated without incident over a 5-month period at Fort Wainwright. The highest time on any one pocket was 80 hours. During this time period the temperature range was +20°F to -50°F and the aircraft flew at varying gross weights up to 47,000 pounds.

Two of the Fort Eustis pockets were found to be partially disbanded after accumulating approximately 16 and 6 hours. Total time for all pockets was approximately 250 hours.

As a precautionary measure, all nine flight rotor blades containing the experimental pockets were removed from aircraft (four blades at Fort Eustis, Virginia and five blades at Fort Wainwright, Alaska).

POCKET EXAMINATION

Based upon examination of the Fort Eustis rotor blades and by performing laboratory small specimen peel tests, it was concluded that the EA 9203 primer normally coated directly to the anodized surface of the pocket skin had been applied over pocket surfaces inadvertently coated with undetected EA 9202 primer. The EA 9202 is the primer base used for assembling pocket stringers to pocket skins. When the EA 9320 adhesive was used to bond on the experimental pockets to the blade spars, the EA 9202 primer beneath the EA 9203 primer became the weak link causing separation of the two pocket skin flanges from the spar.

This conclusion was based on numerous laboratory peel specimen tests conducted at Sikorsky Aircraft. It was possible to duplicate the same low peel strength and shiny surfaces associated with the two disbanded pockets by making peel specimens with EA 9203 primer coated over EA 9202 primer, bonding the specimens with EA 9320 adhesive and performing peel tests on these specimens.

Other tests were performed to corroborate the present system of EA 9203 primer and EA 9320 adhesive used for bonding the field-replaceable pockets to the blade spar. It was reaffirmed that high peel strengths could be obtained with EA 9203 primer and EA 9320 adhesive provided that the EA 9203 primer was properly placed on the anodized panels, the primed

surfaces were wiped clean with cheesecloth soaked with ethyl alcohol and EA 9320 adhesive was placed on the clean panels.

Further specimen tests showed that the EA 9203 primer was sensitive to improper bonding procedures and resulted in poor peel strengths when: a) the surface of the primer was not cleaned with ethyl alcohol; b) the surface of the primer was contaminated by dirty or soiled cheesecloth; c) dry cheesecloth, improperly soaked with ethyl alcohol scuffed the primer surface; and d) the primer was contaminated with fingerprints from handling without gloves. These tests indicated that significant care is required since any of the above could cause poor installation in the field. The results of these tests are shown in Table 11.

Because of the sensitivity of the EA 9203 primer, additional specimen tests were performed with three other primer/adhesive materials to develop a tougher base for the EA 9320 adhesive; i.e., a system which would be less susceptible to handling, contamination, etc. Tests were performed with EC 1290 primer and combinations of EA 9202 primer and precured EA 9602.3 adhesive acting as an adhesive base. These materials were found to be unsuited with EA 9230 adhesive because of low peel strengths. Other tests utilizing EC 1290 primer and AF 6 precured adhesive as a base coat for the EA 9320 adhesive produced excellent results. This combination (EC 1290/AF 6) is presently used to bond production pockets to production CH-54B rotor blades. The results of the investigation for a new primer base are shown in Table 12.

Peel specimens with this combination of EC 1290 primer/AF 6 precured adhesive and EA 9320 adhesive were fabricated under various conditions. Some specimens were assembled without cleaning and others were purposely contaminated with fingerprints and soiled cheesecloth. All specimens produced high peel strengths. Tests conducted at both 300°F and 350°F cure showed slightly higher values for the 350°F cure (see Table 13).

There are other advantages of the EC 1290 primer and AF 6 adhesive. The AF 6 adhesive, which is applied over the EC 1290 primer, is covered with a nylon peel ply during its cure cycle of 300°F for 1 hour @ vacuum pressure equivalent to 15 psi. The removal of the nylon peel ply from the AF 6 adhesive after cure serves as a good inspection test of the AF 6 bonded to the pocket skin because the strength of the nylon to adhesive bond is almost as high as that of adhesive to pocket skin bond. Another advantage is that the AF 6 adhesive is clearly visible, being a yellowish brown color, and its presence or lack of presence is easily detected on the pocket. Since the proposed EC 1290/AF 6 adhesive system is already a production system used for bonding CH-54B pockets to spars, the fatigue strength of the proposed system will be comparable to production.

RECOMMENDATION

Based on the advantages of this new primer system, it is recommended that EC 1290 primer and AF 6 precured adhesive be utilized as the base for EA 9320 adhesive and that pockets with this new design be installed and flight tested at Fort Eustis.

TABLE 11. PEEL STRENGTH OF EA 9320 ADHESIVE WITH PROPER AND IMPROPER PROCEDURE

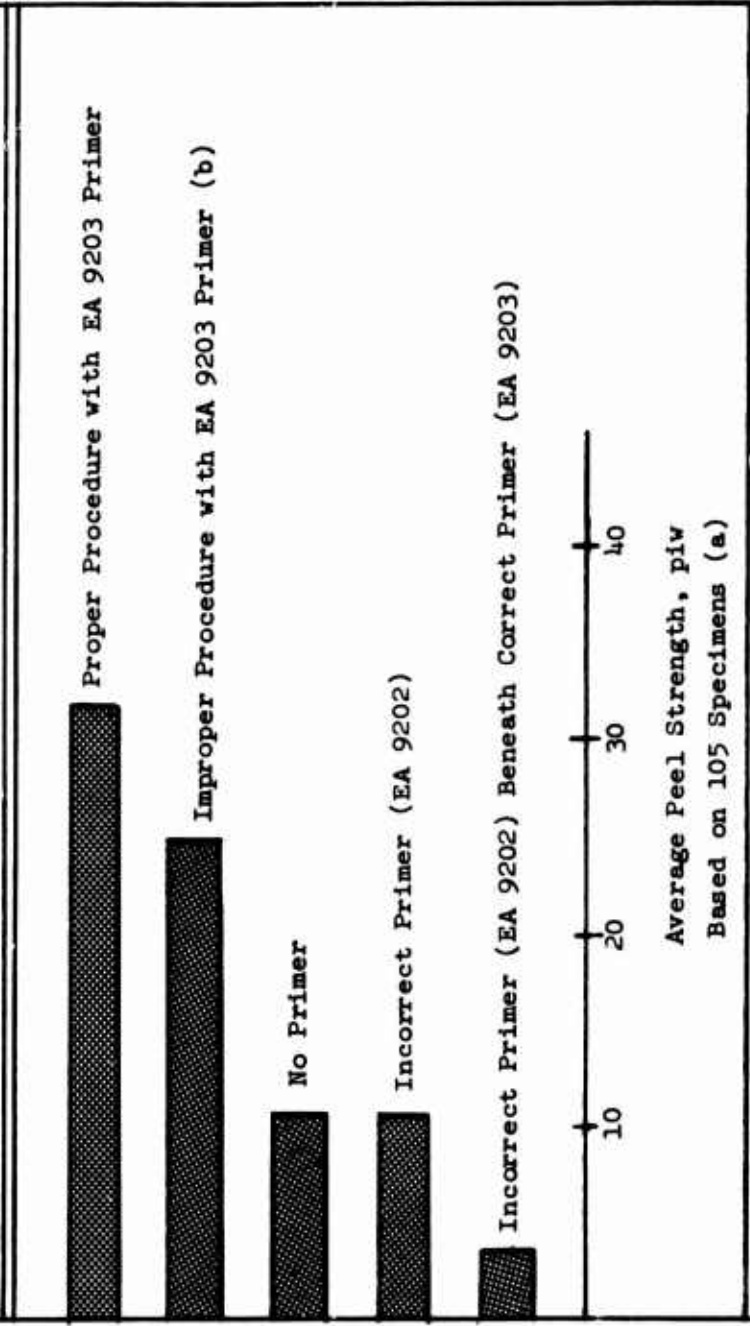

(a) Specimen panels were anodized 6061T6 Al.

(b) Specimens deliberately soiled, contaminated, etc.

TABLE 12. RESULTS OF INVESTIGATION OF NEW PRIMER BASE FOR EA 9320 ADHESIVE

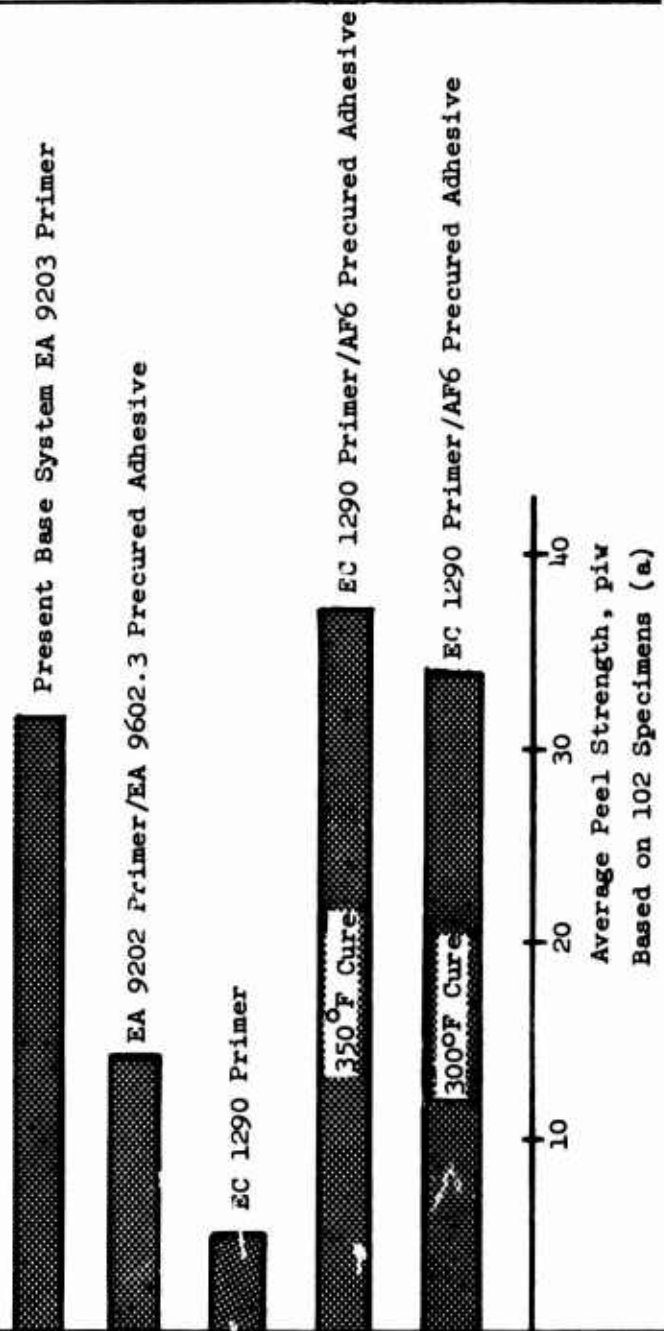

(a) Specimen panels were anodized 6061T6 Al.

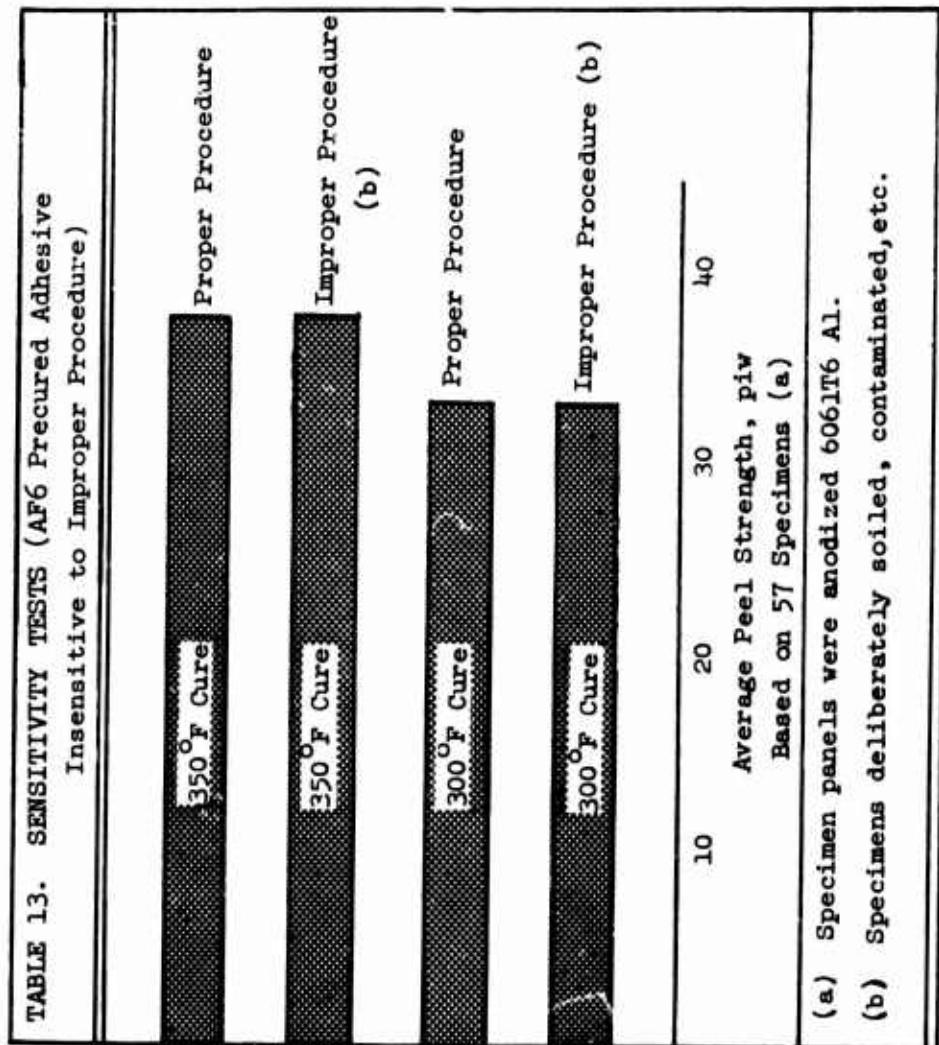

COST ANALYSIS

An analysis was performed to estimate the savings to the Army if replaceable pocket kits were available in the field. A cost comparison was made of:

- a) blades returned to Sikorsky Aircraft strictly for pocket repair
- b) the same blades retained and repaired in the field by Army maintenance personnel

The cost comparison was based on Sikorsky's repair data for CH-54A/B rotor blades for the years 1972 through 1974. Most of the data available was for CH-54A blades since there is not sufficient field experience yet with the CH-54B for the 3-year period. The following analysis was performed:

1. One hundred fifty-nine blades were returned for the 3-year period to the contractor's overhaul and repair facility for an annual average of 53 blades.
2. Forty-eight blades were returned (strictly for pocket repair) over the 3-year period, for an annual average of 16 blades. These 16 blades could have remained in service had field-replaceable pockets been available.
3. One hundred sixty-nine pockets were replaced in the 3-year period. This does not include additional pockets which were removed because of abrasion strip replacement. Currently, a main blade abrasion strip replacement automatically requires the removal of four pockets because of the bonding tools clamping arrangement to the spar. In this report, this automatic pocket removal has not been considered. Only pockets necessitating replacement due to field damage have been considered. The average annual number of pockets replaced per blade at the contractor's facility was 3.5 pockets ($169/48 = 3.5$).
4. The number of pockets required per year in the field to effect pocket repair is equal to $(3.5)(16)$, or 56 pockets. The average number of pockets required per year to supply the Army's inventory with a 90% confidence is 66 pockets.
5. Cost of one field bonding fixture
6470-10052 \$200.00
Cost of one pocket kit including pocket,
spacers, adhesive etc. \$200.00
Man-hours to replace one pocket (average) 1
6. No change in maintenance man-hours per flight hour at the organizational level of maintenance is anticipated. An increase of approximately .003 maintenance man-hour per flight hour is anticipated at the direct support level of maintenance, which is negligible.

$$\frac{1.0 \text{ hour to replace } 56 \text{ pockets}}{19,229 \text{ flight hours}} = .003$$

(19,229 hr = average flight hours per year)

Aircraft availability should improve due to reductions in down time related to lack of spare blades. A quantitative estimate of this parameter cannot be determined.

7. Cost to Army per Year for Sikorsky Factory Pocket Replacement

| | | |
|----|----------------|---|
| a. | \$ 70.00 | per blade, preparation for shipment to CONUS |
| | \$ 171.00 | per blade, surface shipping to CONUS (8,000 mi.) |
| | \$ 500.00 | per blade, shipping container |
| | \$ 131.00* | per blade, shipping from the West Coast to Sikorsky |
| | \$2,265.00** | per blade, repair charge at Sikorsky |
| | \$ 131.00 | per blade, shipping from Sikorsky to West Coast |
| | \$ 976.00 | per blade, air shipping 8,000 mi. (average) |
| | <u>\$4,244</u> | Total cost of a blade returned to Sikorsky factory |

NOTE: * Shipping cost by truck is \$16.38 per 100 lb with a 10,000-lb minimum. Blade and container weigh 800 lb.
** Repair cost is 1973-1974 negotiated contract price for repairing one CH-54A/B blade.

- b. Average of 53 blades per year returned over the last 3 years = 53 (\$4,244) = \$224,932 per year cost to repair at the factory.
- c. Cost of 16 spare blades which would not be required if blades could have remained in the field (16)(13,075) = \$209,200.
- d. Total cost per year for factory repair

\$224,932 Repair Cost
\$209,200 Blade Spare Cost
\$434,132 Cost for Factory Repair

8. Cost to Army per Year With Field-Replaceable Pockets

| | | |
|----|---|-------------------|
| a. | \$ 5.00 per pocket-military labor for pocket replacement (1.0 hrs @ \$5 per hr) | |
| | <u>\$200.00</u> per pocket - kit | |
| | \$205.00 Total cost per pocket | |
| b. | Average of 56 pockets replaced per year in field = | |
| | 56 (\$205.00) | = \$11,480.00 |
| | 36 field bonding kits required = | |
| | 36 (\$200.00) (assuming six kits at six different bases) | = \$ 7,200.00 |
| | 6 Tapping tools required = | |
| | (6) (\$300.) (assuming six kits at six different bases) | = \$ 1,800.00 |
| | Shipping cost of pocket for 8,000 mi. = 56 (\$1.50) | = \$ 84.00 |
| | Backup spare pocket inventory of 10 pockets - 10 (\$200.00) | = \$ 2,000.00 |
| | Shipping cost of spare pockets = 10 (\$1.50) | = <u>\$ 15.00</u> |
| | Total cost per year for field pocket replacement | \$22,579.00 |

- c. An average of 53 blades per year has been returned for the last 3 years for repair at the contractor's facility, but with field-replaceable pockets only an average of 37 blades per year would be repaired at Sikorsky Aircraft =
 $37 (\$4244) = \$157,028.$
- d. Total cost per year with field-replaceable pockets
 - \$ 22,579 Pocket field cost
 - \$157,028 Repair cost
 - \$179,607 Cost for field repair

9. Savings Per Year to Army

- \$434,132 Factory cost
- \$179,607 Field cost
- \$254,525 Savings per year

It must be noted that the largest percentage of the savings is a result of the need for fewer spare blades. Of the total savings per year, the greatest impact is the requirement for 16 less spare blades; therefore, the total savings can fluctuate drastically, depending upon the activity and usage of the CH-54B aircraft.

CONCLUSIONS

Results of all ground tests covering proof load, fatigue and whirl tests have proven the structural integrity of the EA 9320 adhesive system and the EWR 38633 pocket assembly.

The proof load pockets tested under various environmental conditions were considerably higher than the ultimate proof load requirement of 565 pounds established under Reference 1. The average load of the field-replaceable pocket was close to 1200 pounds.

The fatigue tests indicated that the fatigue strength of the EWR 38633 pocket was superior to the production pocket and that the EA 9320 adhesive was as good as the AF 6 production adhesive.

The whirl tests established that aerodynamic performance was not affected by the out-of-balance caused by the installation of field-replaceable pockets on blades. The 25 hours of endurance whirling also showed that the adhesive bond voids obtained during installation of field-replaceable pockets at Sikorsky had little or no additional separation, upon examination, after completion of whirling.

Flight tests conducted at Sikorsky Aircraft demonstrated that up to 17 pockets could be flown without decreasing blade life. The controllability and vibrational levels remained the same as a standard CH-54B aircraft.

Thirty-five field-replaceable pockets were flown at Fort Eustis, Virginia and Fort Wainwright, Alaska. Two of these pockets became partially separated during flight test. Investigation of the two disbonds revealed the need for improving the bonding procedure. Additional field-replaceable pockets, with an improved method of surface preparation of the pocket skins, have been fabricated for further evaluation on CH-54B blades in the field.

A cost comparison was conducted for repairing the current CH-54 helicopter main rotor blades using factory support and the candidate main rotor blade with field-replaceable pockets. Based on Sikorsky repair data for the years 1972 through 1974, a savings of approximately \$250,000 per year can be realized when field-replaceable pockets are incorporated in the Army inventory.

It is therefore concluded that the field-replaceable pockets are both structurally and economically suited for field evaluation.

RECOMMENDATION

It is recommended that EWR 38633 pockets with the improved primer system be installed on rotor blades and flight tested at Fort Eustis. Pockets should be inspected every 10 hours until 100 hours have accumulated. At the completion of the 100 hours of testing, pockets should be subject to same inspection as production pockets until blades are returned for overhaul.

REFERENCES

1. Galli, C. V., and Meck, P. A., FIELD-REPLACEABLE ROTOR BLADE POCKET STUDY, Sikorsky Aircraft, USAAMRDL Technical Report 72-69, Eustis Directorate, U. S. Army Air Mobility Research and Development Laboratory, Fort Eustis, Virginia, February 1973, AD 759956.
2. Weckman, R. G., STRUCTURAL SUBSTANTIATION OF THE S-64F/CH-54B FOR FAA TYPE CERTIFICATION, Sikorsky Engineering Report 64500, April 1970, Contract DAAJ01-68-C-0827.

APPENDIX A

ADHESIVE PROOF LOAD TEST PLAN

PROOF LOAD REQUIREMENTS

Proof Load Test Quantity

Sikorsky Aircraft will perform a total of 17 proof load tests consisting of 3 production and 14 replaceable pockets to demonstrate the static strength of the replaceable pocket with the selected adhesive. Proof testing will be done with the #2 pocket with backwall spacers on CH-54B spar sections. The #2 pocket is chosen because it is the most outboard pocket requiring a backwall spacer and is subjected to the highest aerodynamic loads. The 17 proof load specimens consist of the following tests:

- a) The first three proof load spar specimen tests will utilize production pockets with the selected adhesive.
- b) The next three proof load specimen tests will utilize replaceable pockets with the selected adhesive and having the unsupported skin at the spar backwall uncoated with the selected adhesive. Refer to Detail A of Figure A-1.
- c) The next three proof load specimen tests will utilize replaceable pockets with the selected adhesive and having the unsupported skin at the spar backwall coated with additional paste adhesive. Refer to Detail B of Figure A-1.
- d) The next six replaceable pocket proof load specimen tests, with the selected adhesive, will be utilized to evaluate effects of chemical heat packs on the selected adhesive cure time. Refer to Chemical Heat Packs Test Plan, Appendix B.
- e) The last two proof load specimen tests will utilize replaceable pockets with the selected adhesive to determine feasibility of replacing a replaceable type pocket.

The proof load spar sections will be bonded with production pockets per production procedures and then have the pockets removed to expose the residual adhesive for subsequent bonding of replaceable pockets with the selected adhesive. The replaceable pockets will be bonded to prepared spar sections and the necessary spacers with the selected adhesive.

Proof-Load-Pocket-to-Spar Bonding

All pockets will be bonded to spar sections in a replaceable pocket fixture. The adhesive will be the selected adhesive utilizing an ambient temperature curing system mixed per the manufacturer's recommendations. Curing of the adhesive will be at ambient temperature and humidity except as noted for the chemical heat pack evaluation.

Pocket Proof Load Tests

Test Conditions

- (a) Proof load tests of the pocket-to-spar bond specimens shall be conducted at prevailing ambient temperature and humidity atmospheric conditions.

Test Equipment

- (a) SL65B-1032 Static Proof Load Fixture.
- (b) SLGNB 1089-49 Support Assembly Jig Fixture.
- (c) Riehle Tensile Testing Machine (60,000-lb capacity).
- (d) Dial Indicators.

Quality Assurance

- (a) Measurement equipment listed above shall be subjected to normal periodic calibration.

Test Connections

- (a) Attach the support assembly jig fixture to the spar 1/4 in. beyond each edge of the pocket on the blade specimen.
- (b) Place the test assembly between the compression heads of the Riehle testing machine.
- (c) Position the pad assembly of the static proof load fixture over the upper pocket surface of the blade specimen as shown in Figure A-2. Pad marked trailing edge will be located nearest the trailing edge of the pocket.
- (d) Connect the dial indicator to the pocket trailing edge to measure deflection under load.

Test Procedure

- (a) Apply the load gradually to the pad assembly in increments of 100 pounds until the required design proof load is reached. Proof load requirements were established under Reference 1. The ultimate proof load on Pocket #2 was 565 pounds.
- (b) Maintain design proof load for 3 minutes.
- (c) Measure deflection at 100-pound increments and design proof load.
- (d) Release load and conduct a visual examination to determine existence of any evidence of fracture or permanent deformation (plot dial indicator readings for permanent set determination).

- (e) Reapply and increase load on the specimen until fracture occurs or until the specimen no longer sustains additional load.

Evaluation of Results

- (a) Comparison of proof loads between production and field replaceable pockets.
- (b) Determine mode of fracture for each specimen.

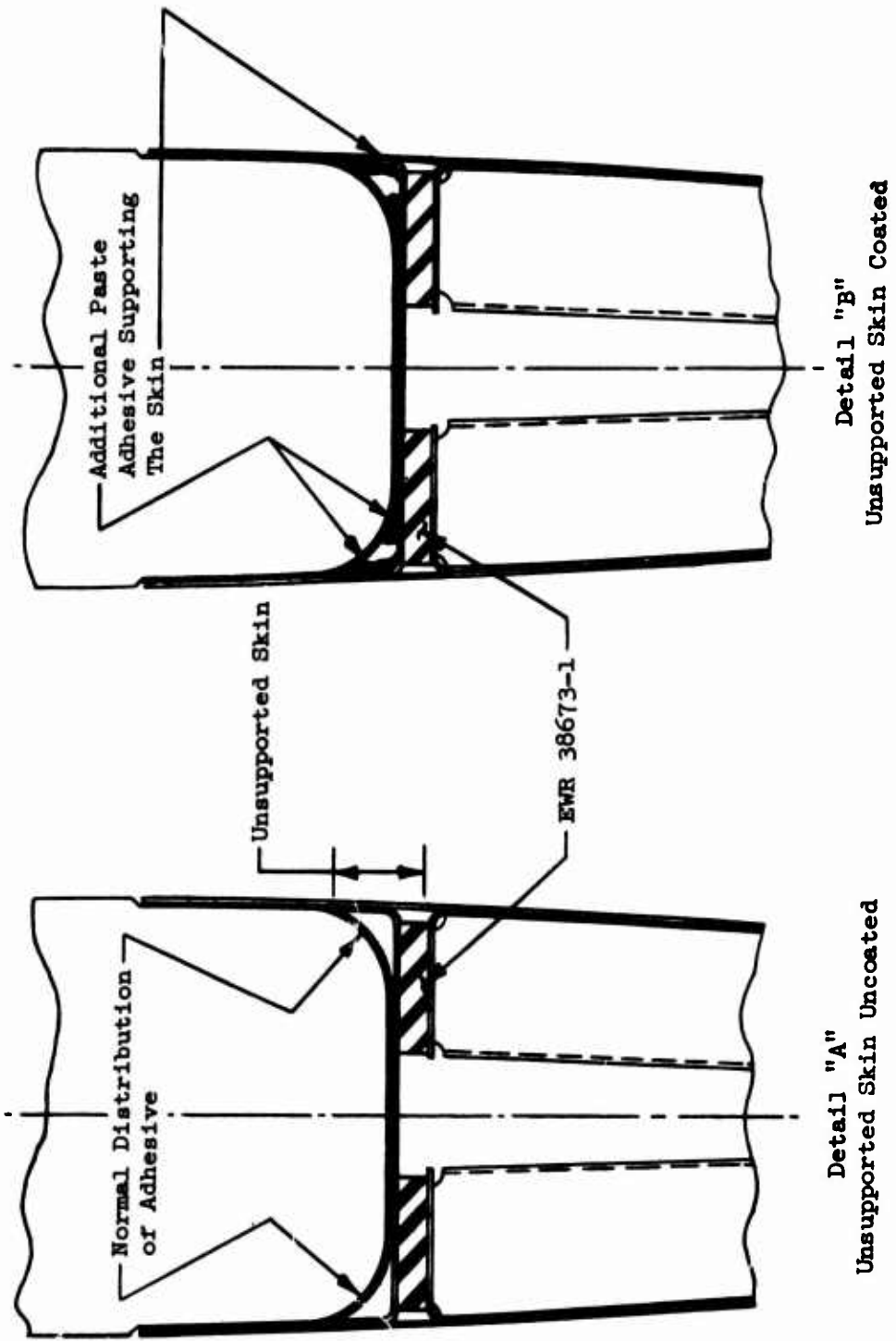

Figure A-1. Proof Load Test - Additional Paste Adhesive.

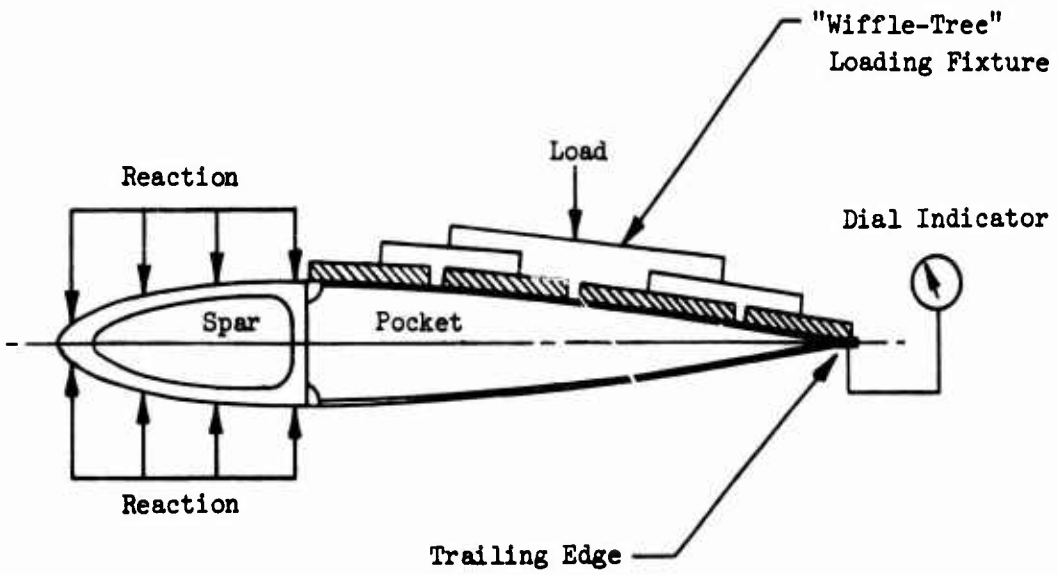

Figure A-2. Static Proof Load Pocket Specimen.

APPENDIX B

CHEMICAL HEAT PACKS TEST PLAN

Sikorsky Aircraft will perform a minimum of six proof tests of the replaceable type pockets bonded to spar sections with the selected adhesive and cured with the aid of chemical-heat packs.

Because the proposed replaceable type pocket does not require a side shim bond similar to Reference 1, only the pocket-to-spar bond area will require a chemical-heat pack. Therefore, only one heat pack will be used per side.

Heat cycles will be conducted on specimens at 75°F and 40°F by imbedding thermocouples in the pocket-to-spar bond line and monitoring the temperature developed by the heat pack. Cure cycle time will be calculated from Table B-1 and Figure B-1. After the heat cycle runs, these cycles will then be used to bond six proof load specimens, three each at 75°F and 40°F. Testing will be conducted after the specimens are considered cured, in accordance with the Adhesive Proof Load Test Plan, Appendix A.

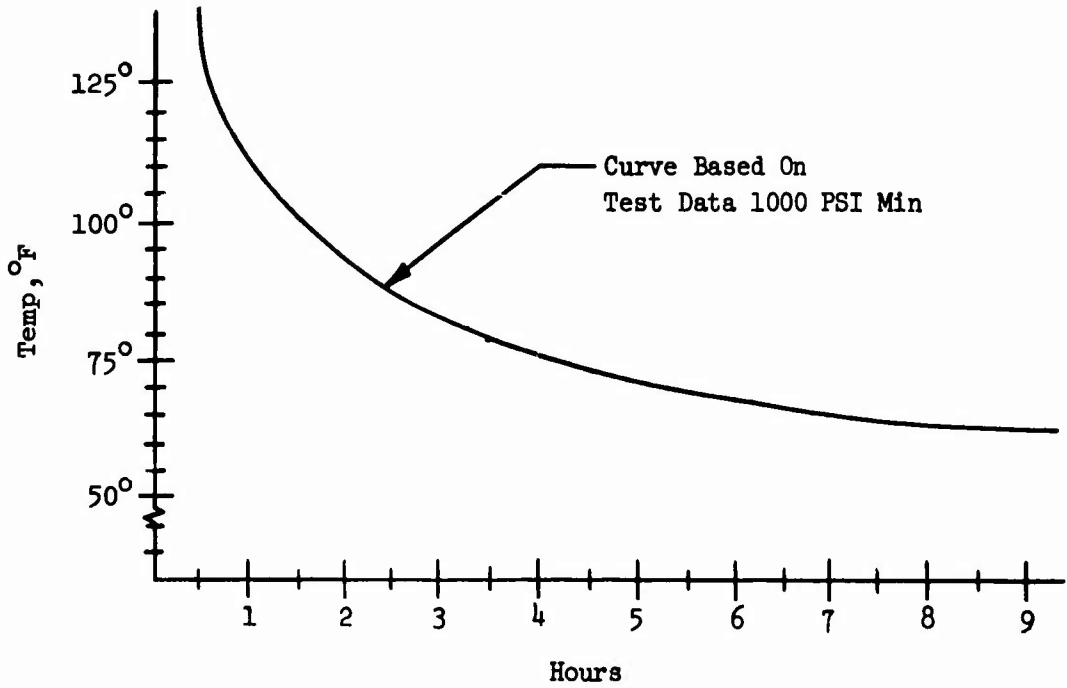

Figure B-1. Time to Cure EA 9320 Adhesive to 1000-PSI Shear Strength.

| TABLE B-1. TIME TO CURE EA 9320 TO 1000 PSI SHEAR STRENGTH. | | |
|---|-----------------------|-----------------------|
| Cure 100°F & 85% RH | Cure 75°F & 50% RH | Cure 40°F & 20% RH |
| Hours — PSI | Hours — PSI | Hours — PSI |
| 1.5 — 600 | 4.0 — 900 | 42 — 790 |
| 2.0 — 3200 | 5.0 — 1426 | 45 — 1290 |

APPENDIX C
FATIGUE TEST PLAN

SCOPE

Purpose

The purpose of these tests is to evaluate replaceable pockets and the Hysol EA 9320 pocket-to-spar adhesive bond system under fatigue loading.

Background

These tests are part of an Army development program to evaluate the concept of field-replaceable pockets. In this concept the replacement pockets would be bonded to the spar, in the field, using a room temperature curing adhesive instead of the elevated temperature curing adhesive presently used in production. The objective of the work to be performed under this contract is to refine the pocket design and adhesive developed under Contract Number DAAJ02-71-C-0022 and to validate its suitability for field use.

APPLICABLE DOCUMENTS

Contract No. DAAJ02 73-C-0076.

Contract No. DAAJ02-71-C-0022

Sikorsky Aircraft Drawing SL65B-1016, "Outboard Resonance Fatigue Test Specimen"

REQUIREMENTS

Experimental Test Design

Fatigue testing of CH-54B outboard blade specimens will be conducted in both the 60,000-lb and 100,000-lb universal blade fatigue test machines. Each of seven test specimens will be subjected to step fatigue testing under combined flatwise and edgewise bending loadings for 3×10^6 cycles at each load level. The test load levels will be 10,500 psi steady tensile stress (resulting from centrifugal loading) and $\pm 4,000$ psi, $\pm 7,000$ psi and $\pm 10,000$ psi vibratory stresses at the entrance to the bottom rear (BR) corner radius of the spar.

The seven fatigue test specimens will have the following pocket/adhesive conditions:

- (a) The first specimen will contain five production pockets. The center pocket will be bonded using standard production bonding procedures. Two additional pockets will utilize the selected adhesive at 50% of the manufacturer's minimum recommended pressure. Two psi will be used for this condition. The last two pockets will utilize the selected adhesive at the manufacturer's minimum recommended pressure, which is 5 psi.

- (b) The second, third and fourth specimens will contain five replaceable pockets for each specimen. The pockets will be bonded with the selected adhesive using the field bonding fixture and bonding room ambient temperature and humidity conditions.
- (c) The fifth and sixth specimens will contain one production pocket for each specimen. These pockets will be located at the center and will be bonded using standard production bonding procedures. Each specimen will also contain four replaceable pockets with the selected adhesive bonded under the following field conditions and variables:
 - (1) Spar surface condition - residual adhesive removed.
 - (2) Bonds using full and average shelf-life adhesive.
 - (3) An improperly mixed adhesive - an adhesive that has not had its separate components properly blended.
 - (4) Pockets replaced in a hangar type environment.
 - (5) Effects of chemical heat packs.

The four replaceable pockets for each specimen will be bonded using the field bonding fixture.

- (d) The seventh specimen will contain one production pocket at the center and will be bonded using standard production bonding procedures. The remaining four pockets will be replaceable pockets utilizing the selected adhesive. The field conditions under which these pockets will be tested will be dependent upon the test results of the fifth and sixth fatigue specimens. The four replaceable pockets for this specimen will be bonded using the field bonding fixture.

The fatigue specimens containing replaceable pockets will first be bonded with production pockets per production procedures. The pockets will then be removed to expose the residual adhesive for subsequent bonding of replaceable pockets with the selected adhesive to simulate conditions to be experienced in the field.

Centrifugal loading of the specimen will be simulated by compression of a series of large rubber washers attached through calibrated straps to the outboard end of the blade. The blades will be subjected to vibratory bending loads, under semiresonant conditions, as pin-pin beams, which will be excited by a rotating eccentric crank attached at the outboard end. The blades will be positioned at an angle so that both edgewise and flatwise loadings will be simultaneously applied. The ratio of NB to BR vibratory stresses will be maintained at 77%. This represents the ratio of flatwise bending stress to bending stress at the bottom rear corner radius of the spar and is representative of most flight conditions. Each test condition will be set up and monitored using amplitude measurements in the same manner as similar tests conducted during Contract DAAJ02-71-C-0022.

During that program, one blade was instrumented as shown in Figure C-1, physically calibrated, by means of deadweight, and used to establish the test conditions shown in Table C-1. Once each test condition was established, centrifugal load, blade angle, and vibratory amplitude at 1/4 and 1/2 span were recorded for use in establishing the test conditions on the subsequent test specimens, none of which were strain gaged. The resultant spanwise BR stress distributions from the survey are shown in Figure C-2. Figure C-3 shows the test setup.

Each specimen will be tested according to the schedule shown in Table C-1 and periodically inspected (approximately every 0.5×10^6 cycles) for bonding failure by the Blade Shop Bonding Inspector. Bonding failure will be determined by the total amount of separation of pocket from spar as measured per Figure C-4.

Facility Requirements

All testing will be performed in both 60,000-lb (Test Levels 1 and 2) and 100,000-lb (Level 3) universal blade fatigue test machines. Standard adapter end fittings will be required to attach the blade specimen to the machine and permit orientation of the blade with respect to the plane of motion of the eccentric crank to obtain combined flatwise and edgewise vibratory loading.

Instrumentation Requirements

The following instrumentation will be required for these tests:

- (1) scale, 1 ft length, 1/64 inch divisions
- (2) Sikorsky SR-4 strain indicator console
- (3) metal strike and pressure sensitive paper for amplitude measurement at 1/4 and 1/2 blade specimen span

PROCEDURES

Each specimen will be initially installed in the 60,000-lb test machine and centrifugal load applied to establish the 10,500 psi steady BR stress. The vibratory amplitude at 1/4 and 1/2 span, equivalent to the first test level shown in Table C-1, will be established and this condition will run until 3.0×10^6 cycles are accumulated. Approximately every 0.5×10^6 cycles an inspection of the bond will be performed. Testing will continue in a similar manner for the second and third test levels, except that all third-level testing will be accomplished in a 100,000-lb fatigue test machine.

DOCUMENTATION OF RESULTS

The results of all tests will be summarized in a test report.

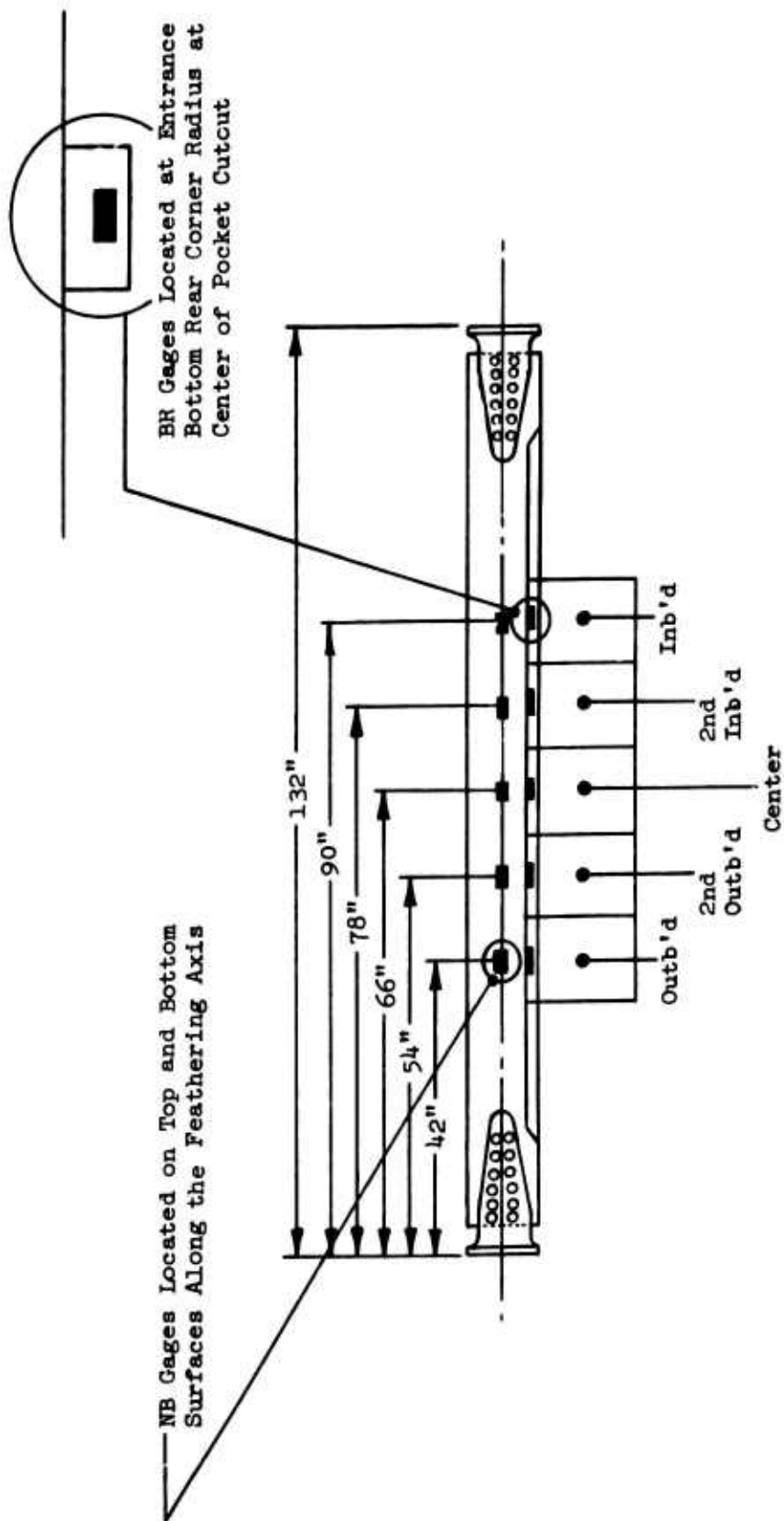

Figure C-1. Previous CH-54B Blade Gage Locations.

| TABLE C-1. CH-54B POCKET-TO-SPAR ADHESIVE BOND FATIGUE TEST CONDITIONS | | | |
|--|-----------------------------------|---|--------------------------|
| Test Condition | Steady BR Stress @ Mid-Span (PSI) | Vibratory BR Stress @ Mid-Span (\pm PSI) | Cycles X 10 ⁶ |
| 1 | + 10,500 | \pm 4,000 | 3.0 |
| 2 | + 10,500 | \pm 7,000 | 3.0 |
| 3 | + 10,500 | \pm 10,000 | 3.0 |

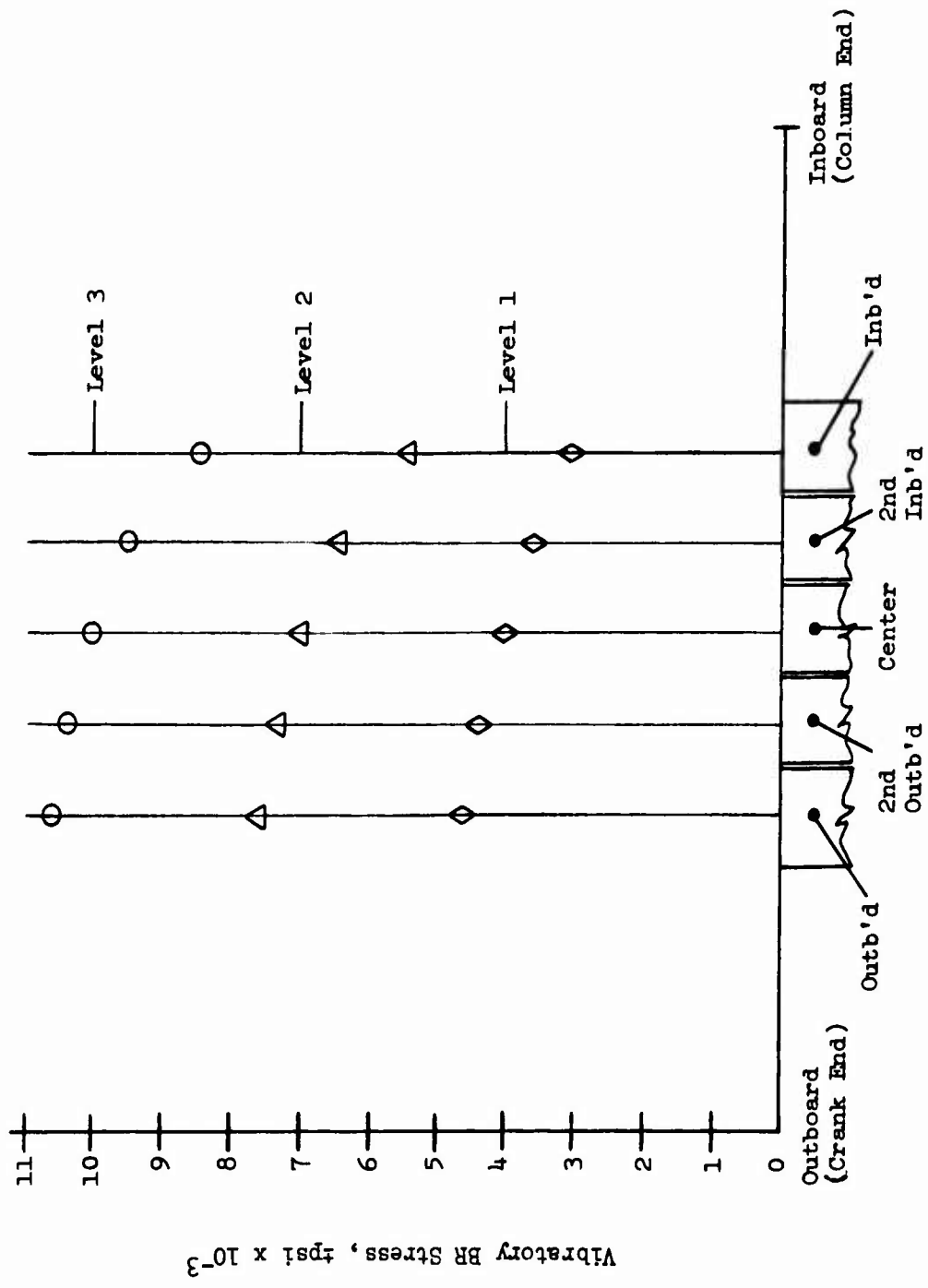

Figure C-2. Vibratory BR Stress Distribution.

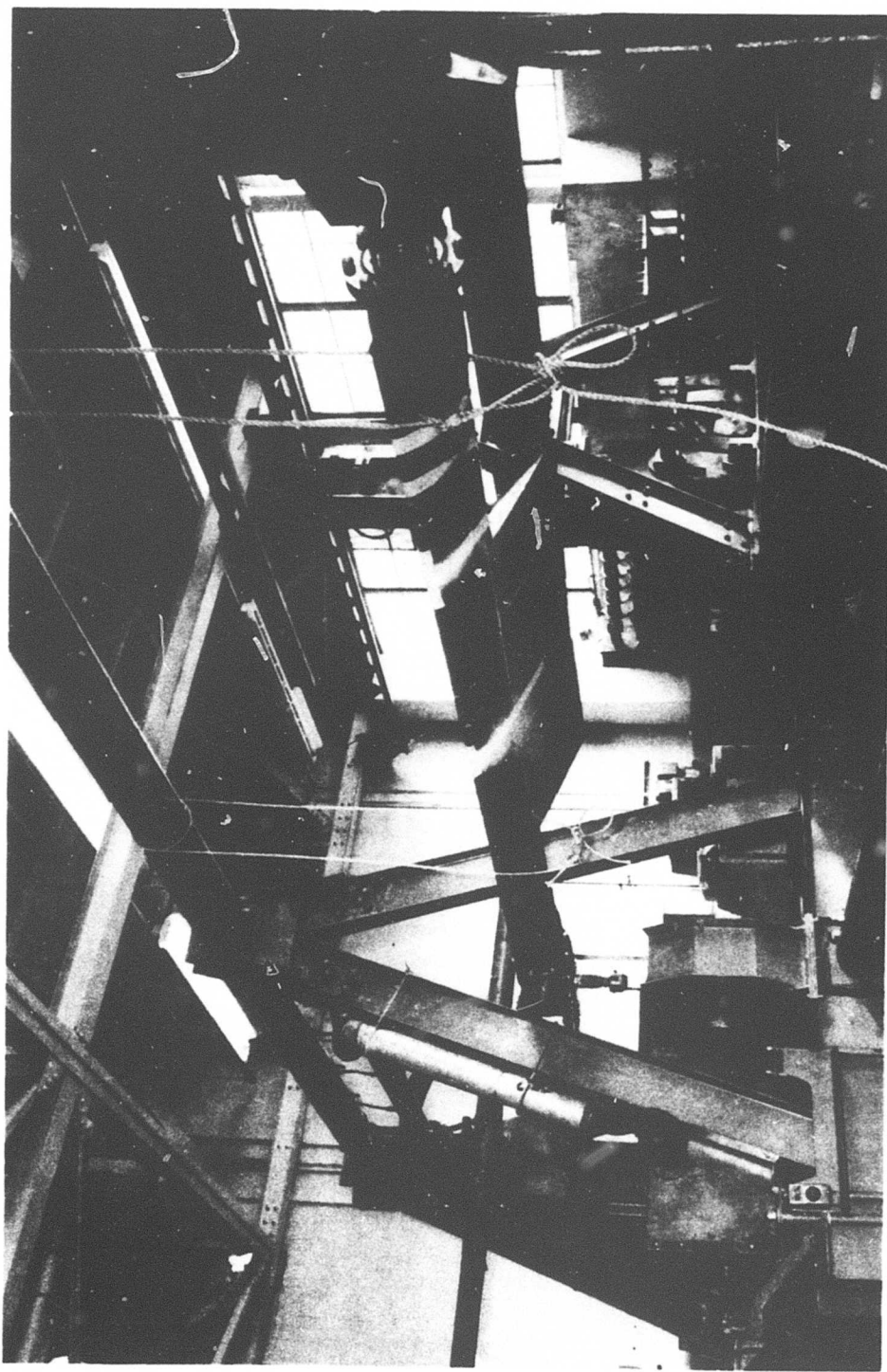

Figure C-3. Adhesive Bond and Pocket Fatigue Specimen Setup in 100K lb Machine.

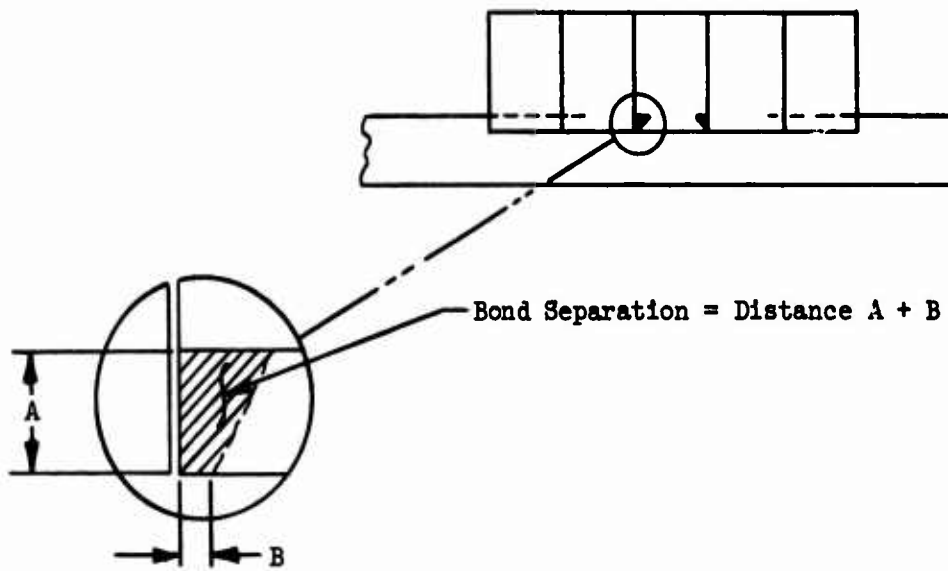

Figure C-4. Measurement of Pocket Bond Separation,

QUALITY ASSURANCE

Inspection

Both the test specimen and test installation will be carefully inspected to assure conformity, alignment, assembly procedure and any other parameters which could affect the test data.

Each blade specimen will be inspected to ensure that it has been machined and fabricated according to specimen design and that the blade pockets are bonded as specified by design requirements.

An inspection of the pocket-to-spar bond shall be made every 0.5×10^6 cycles until 3.0×10^6 cycles are accumulated at each of the three test levels. A sketch such as that shown in Figure C-5 shall be prepared after each inspection showing bonding deterioration.

Calibration

All measurement systems used in these tests shall be calibrated in accordance with MIL-C-45662A and shall display a current calibration sticker.

Witnesses

The Contracting Officer at USAAMRDL and NAVPRO will be notified at least 10 days prior to the start of testing to enable witnesses to be present if required.

Pocket-to-Spar Adhesive Bond Fatigue Test

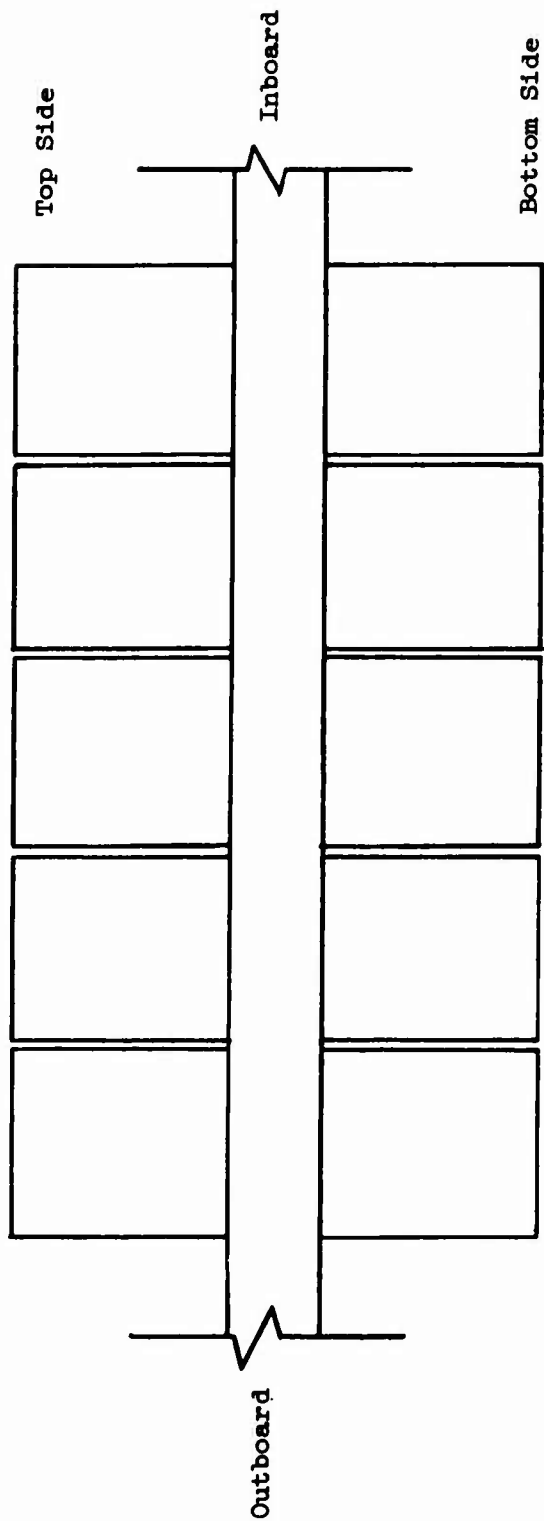

Test No. _____ Blade S/N _____

Test Level _____ No. Cycles _____

Date _____

Figure C-5. Inspection Summary Data Sheet.

APPENDIX D

WHIRL TOWER TEST PLAN

SCOPE

Summary

The feasibility of a bonded field-replaceable main rotor blade pocket has been successfully demonstrated. Under Contract DAAJ02-71-C-0022 a replaceable type bonded pocket was designed, fabricated and laboratory tested. An adhesive compatible with field environment was tested, and a simple lightweight fixture for installing the replaceable type pocket in the field was designed and tested with successful results. A cost analysis indicated that substantial savings can be realized using the field-replaceable pocket concept.

This test plan defines whirl tests to be conducted to evaluate the bonded field-replaceable pockets on CH-54B main rotor blades. These tests are in accordance with the requirements of Contract DAAJ02-73-C-0076.

Date and Place

The whirl tests on the CH-54B bonded field-replaceable pockets will be conducted on Sikorsky Aircraft's 3000 hp blade balance test stand and 10,000 hp main rotor test stand located at Stratford, Connecticut, in January 1974.

Witnesses

Prior to conducting the tests described herein, the local Naval Plant Representative (NAVPLANTREP) will be notified in sufficient time to permit his witnessing the tests.

Purpose

The purposes of this test are to:

- (1) Determine the effects of field-replaceable pockets on blade dynamic and aerodynamic balance.
- (2) Determine the effects of field-replaceable pockets on blade performance.
- (3) Demonstrate the airworthiness of the CH-54B main rotor blade with field-replaceable pockets prior to initial flight tests and field service evaluation by a 25-hour endurance test and a brief overspeed test.

APPARATUS

| | <u>Accuracy</u> |
|---|-----------------------|
| 1. 3000 hp Blade Balance Test Stand (Figure D-1) | |
| 2. 10,000 hp Main Rotor Test Stand (Figure D-2) | |
| 3. Load Cells, Revere (Pitching Moment measurement, 1000 lb capacity) | ± 0.25% of full scale |
| 4. Torque Spool, 400,000 ft-lb capacity, Baldwin-Lima-Hamilton | ± 0.25% of full scale |
| 5. SIGNM-1663 Display Unit (3000 hp Stand) | |
| Blade Pitching Moment | ± 1% of F.S. |
| Blade Track | ± .25 inch |
| Coning Angle | ± .25 degree |
| 6. Electronic Blade Track and Lead/Lag Measurement System, Chicago Aerial Model CA-470A | ± 0.25 inch |
| 7. Propeller Protractor | ± 0.1° |
| 8. Strip Chart Recorders, Speedomax Type G, Leeds and Northrup | ± .25% of full scale |
| 9. Light Beam Oscillograph, Consolidated Electronics Corporation, Model No. 124 P-12 | |
| 10. Oscilloscopes, Hewlett Packard Model Series 130 | |

EXPERIMENTAL TEST DESIGN

The whirl test will consist of the following four areas of investigation:

- (1) Dynamic and aerodynamic balance
- (2) Performance evaluation
- (3) Endurance test including start-stop cycles
- (4) Overspeed test

In addition, static spanwise moment measurements will be made before and after replaceable pocket installations to evaluate effect on static balance. These measurements will be made on the ST 1515-20001-T98 static balance scale located in the Stratford blade shop.

The dynamic and aerodynamic balance and the hover performance evaluation will be conducted on the 3000-hp blade balance test facility, Figure D-1. Dynamic and aerodynamic balance consists of blade pitching moment and track

characteristics, relative to a master blade, before and after installation of the replaceable pockets. Differences (if any) in aerodynamic performance due to replaceable pockets will be obtained by measuring blade lead/lag (drag) differences relative to a master blade. These lead/lag measurements will be obtained using a Chicago Aerial electronic blade tracker, Model CA-470A.

Endurance testing and the overspeed test will be conducted on the 10,000 HP main rotor test stand, Figure D-2. Eighty-five percent of the endurance test time (21.25 hours) will be run at 46,000 lb thrust equivalent to approximately 5500 hp. The remaining 15 percent (2.75 hours) will be run at 53,000 lb thrust equivalent to approximately 6900 hp.

The proposed test power and flapping angle spectra are shown in Figures D-3 and D-4 in relation to the corresponding design spectra. The test power levels indicated in Figure D-3 correspond to the 46,000 and 53,000 thrust levels indicated in Table D-1. The proposed test spectra exceed both the design and operational flight conditions.

A total of six 6415-20601 main rotor blades will be used during these tests. A minimum of 15 replaceable pockets will be installed on the six blades.

TEST PLAN

I. Dynamic and Aerodynamic Balance and Performance Evaluation

Prior to removing the original pockets on the six CH-54B main rotor blades, spanwise moment measurements will be obtained using the ST 1515-20001-T98 static balance scale. The blades will then be installed on the 3000-hp blade balance stand, one at a time (using two master blades), and the following parameters will be measured:

- Rotor speed
- Blade pitch angle
- Blade coning angle
- Pitching moment
- Track
- Lead/lag
- Wind speed
- Temperature

At a constant rotor speed of 185 rpm values for the above parameters will be recorded as blade angle is increased from 0° to approximately 10° in 2° increments. In order to obtain minimum variability of test data, tests will be conducted in dry weather (no rain) and winds less than 8 knots.

Following these initial (baseline) runs, the blades will be returned to the blade shop for removal of original pockets and installation of replaceable pockets. Upon completion of pocket installation, the blades will be checked for static spanwise balance and again installed and run on the 3000 hp blade balance test stand as was done previously.

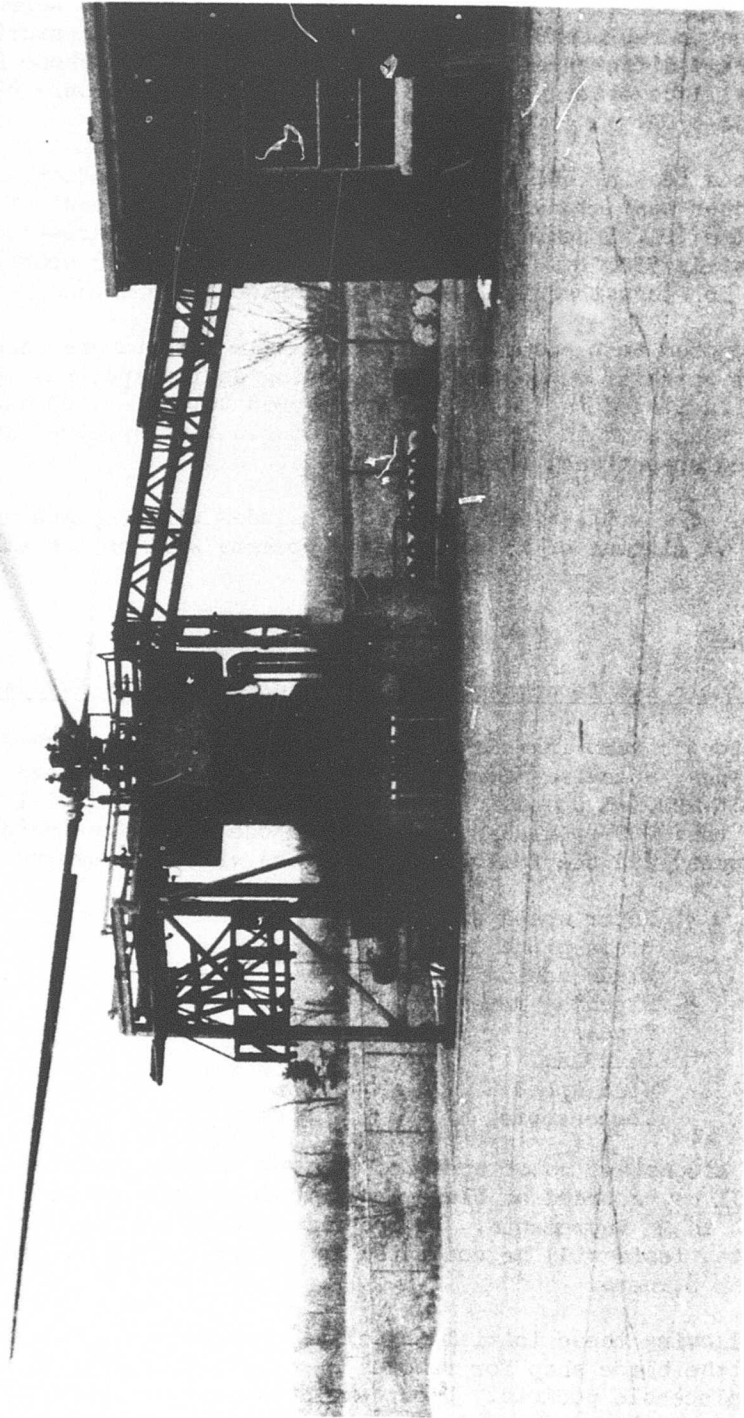

Figure D-1. 3000-HP Blade Balance Test Stand.

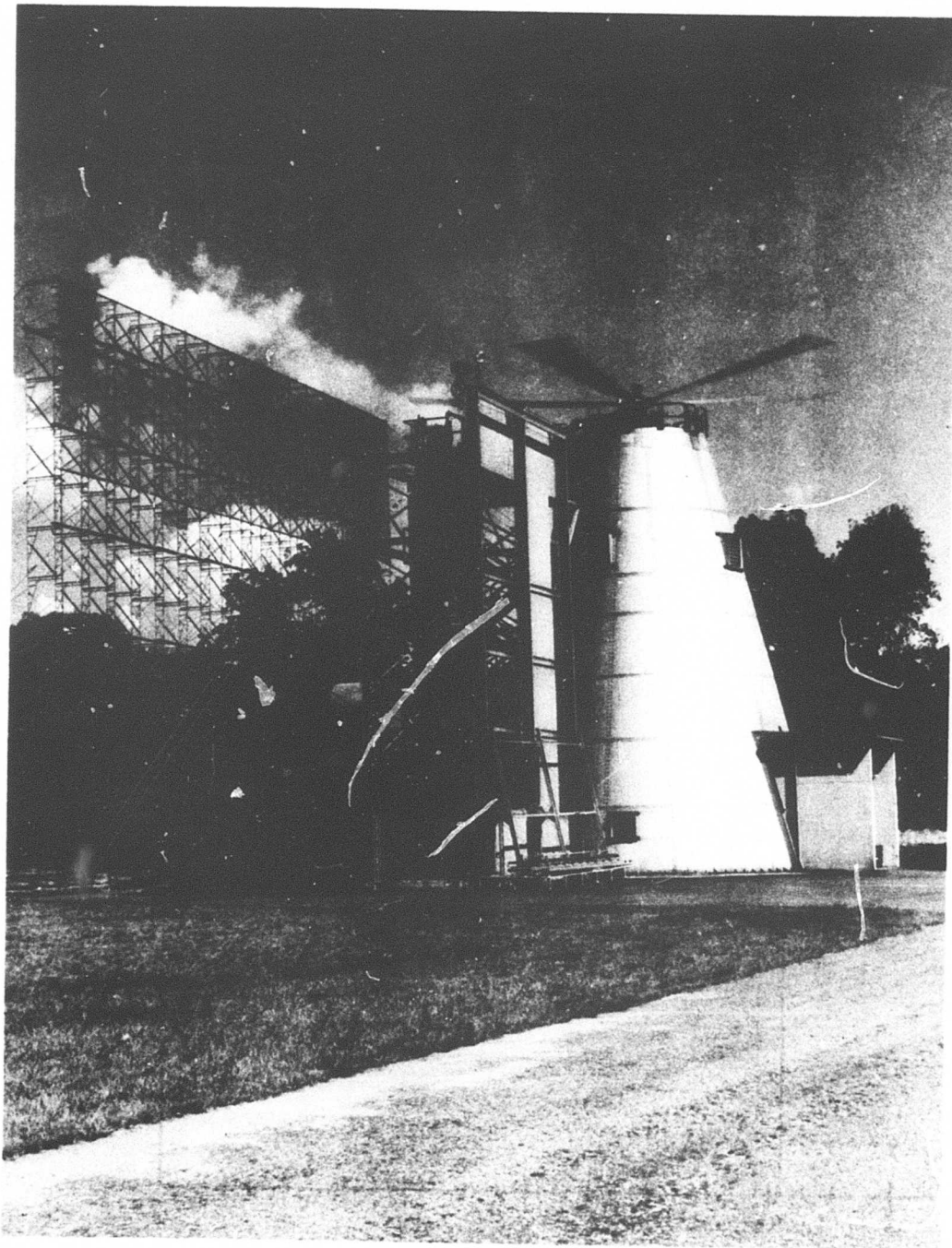

Figure D-2. 10,000-HP Main Rotor Test Stand.

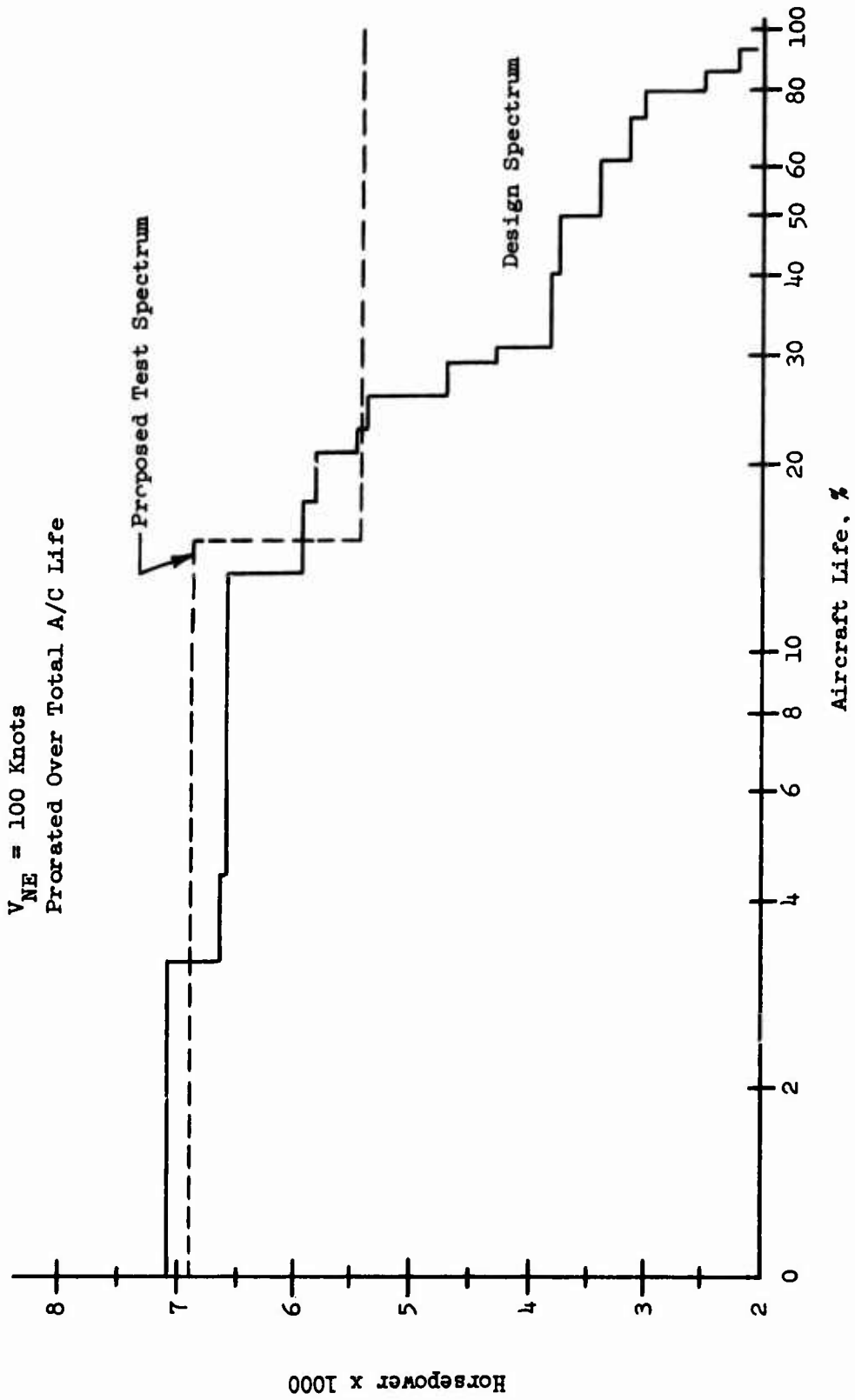
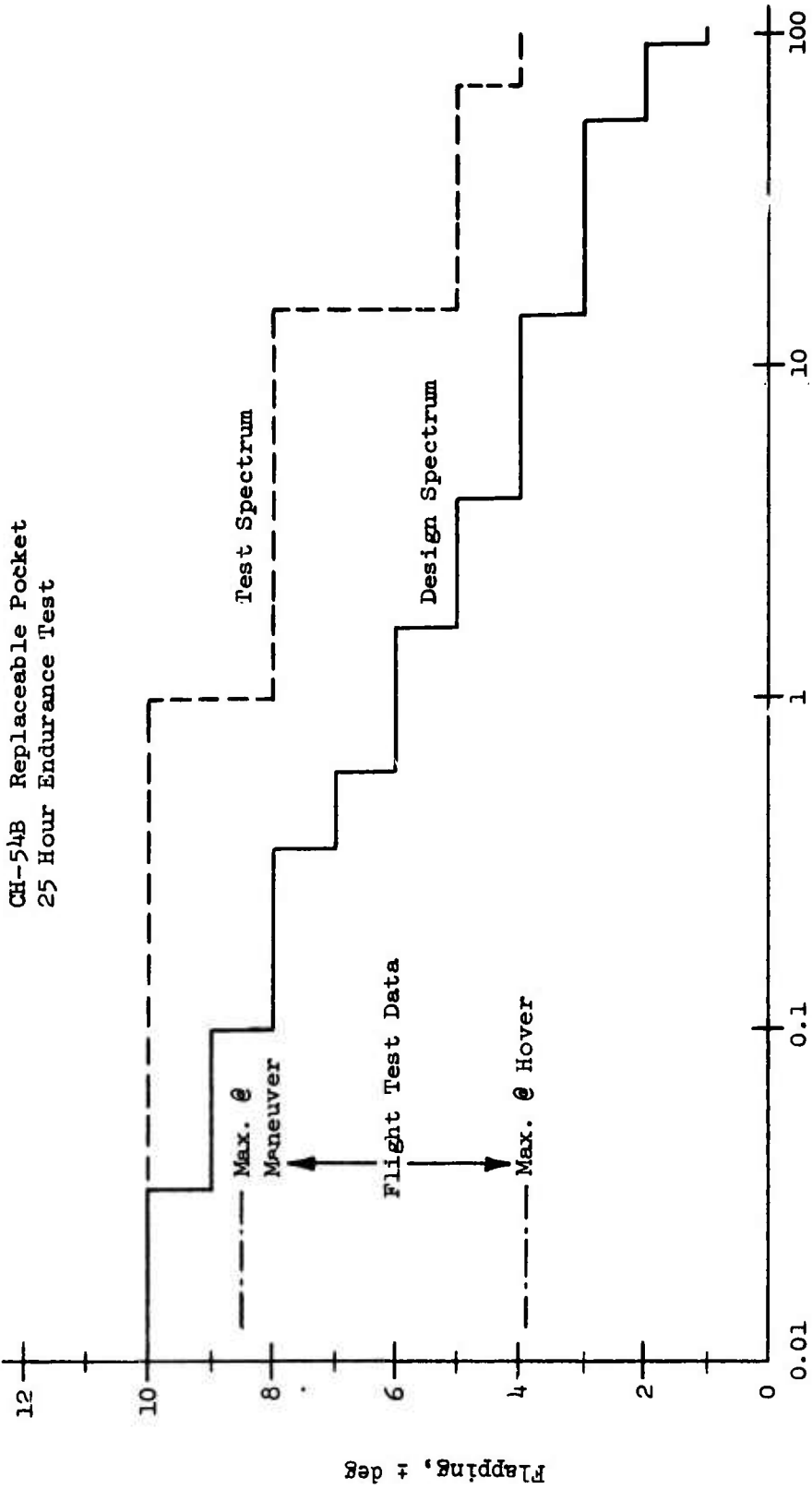

Figure D-3. CH-54B Rotorhead Power Usage Spectrum



Flapping Spectrum Cumulative Percent Time

Figure D-4. Flapping Spectrum.

TABLE D-1. ENDURANCE TEST CONDITIONS

| Cond. No. | Rotor Speed (rpm) | Thrust (lb) | Flapping (\pm deg) | Time per 5-Hr. Block | % Time |
|-----------|-------------------|-------------|-----------------------|----------------------|--------|
| 1 | 185 | 53,000 | 4 $^{\circ}$ | 45 Min | 15.0 |
| 2 | 185 | 46,000 | 4 $^{\circ}$ | 1 Hr | 20.0 |
| 3 | 185 | 46,000 | 5 $^{\circ}$ | 2 Hrs 30 Min | 50.0 |
| 4 | 185 | 46,000 | 8 $^{\circ}$ | 42 Min | 14.0 |
| 5 | 185 | 46,000 | 10 $^{\circ}$ | 3 Min | 1.0 |

Five start-stop cycles/hour will be performed. One start-stop cycle will consist of:

Rotor Speed: 0 to 185 to 0 rpm
 Thrust: 0 to 53,000 to 0 lb
 Flapping: 0 to 4 $^{\circ}$ to 0 $^{\circ}$

Aerodynamic performance effects due to the field replaceable pockets will be evaluated by relating the lead/lag (drag) differences to horsepower (Δ HP).

The Δ HP formula is derived as follows:

The power equation is given by $HP = \frac{QN}{5252}$

where Q = torque, Ft-Lb

N = rotational frequency, RPM

Any change in blade performance will be reflected in blade aerodynamic drag which results in shifting of the blade centrifugal force vector, as shown below:

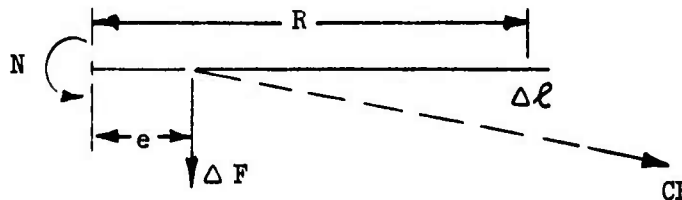

Therefore, $\Delta F \approx \frac{\Delta \ell CF}{R - e}$

where, ΔF = aerodynamic drag force, lb

e = rotor head offset, ft

$\Delta \ell$ = change in lead/lag measurement, ft

R = radius to lead/lag measurement station, ft

CF = blade centrifugal force, lb

The resulting change in torque due to change in blade position is:

$$\Delta Fe \approx \Delta Q \approx \frac{\Delta \ell CF}{R - e} e$$

$$\therefore \Delta HP \approx \frac{\Delta \ell CF e}{R - e} \left(\frac{N}{5252} \right)$$

Test data will be presented in the form of plots of the following relationships:

- (1) Pitching moment versus blade angle
- (2) Track versus blade angle
- (3) Lead/lag versus blade angle
- (4) Δ HP versus blade angle

II. Endurance Test

Following the tests conducted on the 3000-hp stand, the six blades will be installed on the 10,000-hp main rotor test stand for a 25-hour endurance test.

The endurance test conditions are shown in Table D-1. The following parameters will be measured:

- Rotor speed
- Impressed blade angle
- Thrust
- Torque
- Flapping angle

During the endurance test, the rotor will be shut down five times/hour to simulate the static to dynamic conditions (start-stop cycles) experienced by the aircraft during service operation.

Visual inspection of the blade pocket installations will be performed every 5 hours. Pocket-to-spar bonding of the replaceable pockets will be inspected for voids on a daily basis by coin tapping. At the completion of the 25-hour endurance test, a 1-minute overspeed test will be conducted at moderate thrust and 231 rpm (125% N_R).

A daily log will be maintained throughout the test. Log book entries will include records of data measured, weather conditions, periodic inspection results and unusual occurrences.

III. Report Requirements

The results of these whirl tests of CH-54B main rotor blades with field-replaceable pockets installed will be submitted in a final report.

APPENDIX E

FLIGHT TEST PLAN

SCOPE

Summary

The purpose of this flight test program is to evaluate the effect of field-replaceable rotor blade pockets on the CH-54B helicopter flight vibration and handling characteristics. This will be evaluated by flight testing four rotor blade configurations. Blades will be selected from the eight available. Most critical blades will be selected based upon numbers of pockets changed and location, outboard most critical. Each configuration will be tracked prior to flight. Test measurement data will be obtained for each of the flight plan items. Following each flight, each modified blade will be inspected to ascertain safety for continued usage. Tests will be performed at the contractor's Stratford flight area.

Measurements

Measurements will be obtained at the following locations:

1. Aft lateral stationary star load
2. Push rod load on instrumented blade
3. Rotating scissors load
4. Stationary scissors load
5. On each of four modified blades:
 - 3 outboard blade stresses
 - 2 inboard blade stresses

NOTE: At least one of these blades will be installed and measurement taken at each of the four configurations.

The strain gages on four field-replaceable pocket blades will be located on the spar at the outboard bolt holes on the cuff and at 60% and 70% blade radius as shown on Figure E-1. Gages at 60% and 70% radius will monitor blade leading edge stresses, another at 60% radius will be at the back corner of the spar and will record combined flatwise and edgewise stresses at that location. Similarly the gages at the cuff outboard bolt holes will record root flatwise and edgewise stresses. The stresses developed at these locations will be compared to standard blade data having strain gages at the same locations.

6. Vertical, lateral, and longitudinal vibration at copilot
7. Vertical and lateral vibration at main gearbox

8. Longitudinal and lateral cyclic stick position

9. Collective stick position

FOUR FLIGHT TEST CONFIGURATIONS (All Flights - Maximum G. W., Fwd. C. G.)

The first three test configurations will be based on using the rotor blades shown in Table E-1, which gives the spanwise moment out-of-balance resulting from the installation of field-replaceable pockets. The most critical conditions will be tested. The configurations are:

1. One modified blade (3206-1109) will be flown with five standard blades.
2. Three modified blades (3206-1109, 3211-1119, and 2451-1077) installed at adjacent positions and three standard blades.
3. Six modified blades installed.
4. If previous tests indicate no overstress or vibration problems, two additional pockets will be placed on 3206-1109. This will represent an extreme case of five outboard pockets * replaced with field-replaceable pockets on one blade. This blade will be flown with other modified blades depending upon results of the first three test configurations.

* This represents the #2, #3, #4, #5 and #6 pockets.

PLAN A (Configurations 1 through 4)

Nominal Sea Level

Item

- 1 Hover 96, 100, 104 and max. % N_R
- 2 Sideward and rearward flight to 30 and 20 kts; 100% N_R respectively
- 3 Level flight at 40, 60, 80, 100, 105 kts; 100% N_R
- 4 Level flight at 105 kts., at 96, 100, 104 and max. % N_R
- 5 Climb at 60 and 105 kts., maximum continuous power; 100% N_R
- 6 Level flight turns at 80 and 105 kts., Lt. and Rt; 100% N_R plus 96 and 104% N_R at 105 kts
- 7 Symmetrical pull-outs at 80 and 105 kts; 100% N_R
- 8 Rolling reversals at 105 kts; 96, 100, 104% N_R
- 9 Autorotate at 60 and 105 kts. @ max. N_R

10 Approach at 20 kts, 800 fpm ROD and normal to landing; 100% N_R

11 Hover 100% N_R

On first flight, aircraft will be returned to the field to inspect blades at completion of item 6. Blades will also have periodic inspection during the entire program.

Measured parameters will be calibrated before and after each flight.

Data will be processed manually or semiautomatically and compared to previous Army and/or FAA certification data; results and conclusions drawn will be submitted in a report.

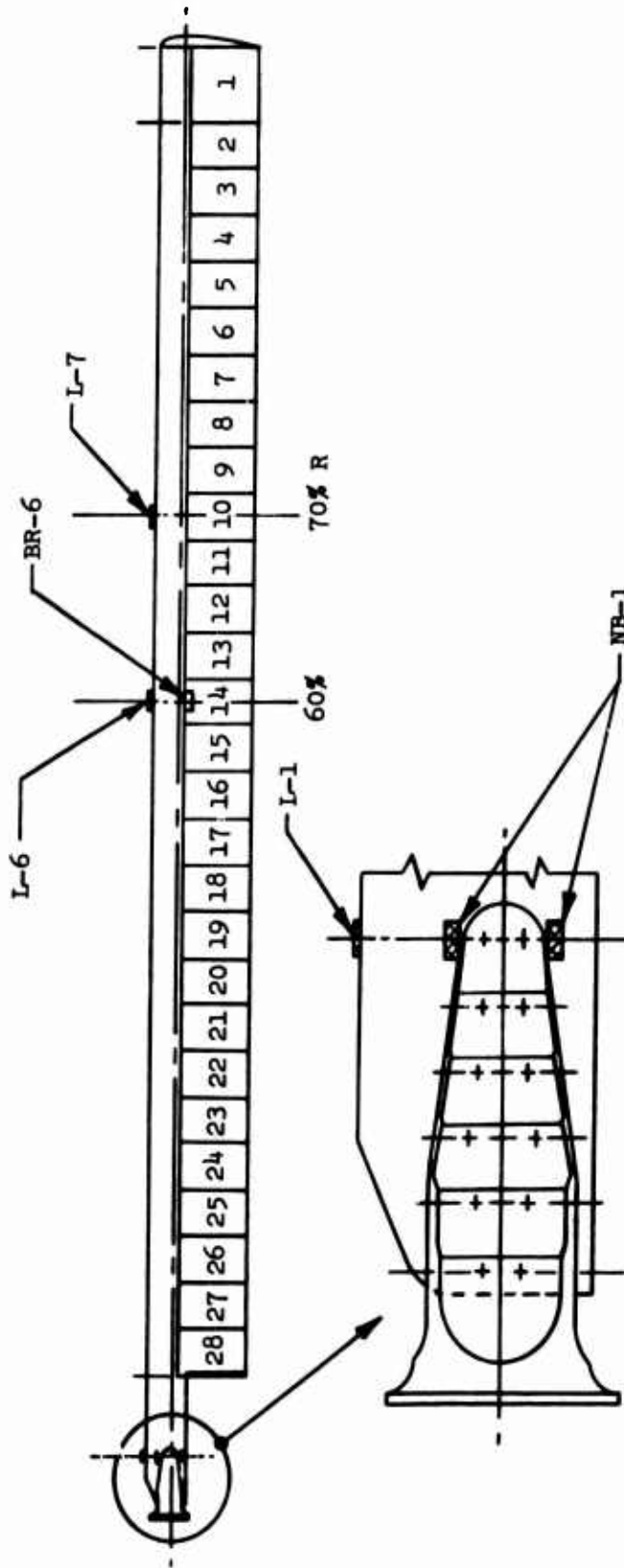

Figure E-1. Blade Strain Gage Locations.

| TABLE E-1. CHANGE IN BLADE SPANWISE MOMENT | | | | |
|--|-------------------------------------|---------------------------------|-----------------------------------|-----------------------|
| Production Blade Serial No. | Spanwise Production Moment (in.-lb) | Pocket Numbers (See Figure E-1) | Spanwise Field Repl Pocket Moment | Δ Mom (in.-lb) |
| 2380-1095 | 78,498 | #9 and #16 | 78,570 | +72 |
| 2399-1097 | 78,497 | #9 and #10 | 78,560 | +63 |
| 2496-1064 | 78,485 | #9 and #10 | 78,533 | +48 |
| 3211-1119 | 78,488 | #17, #18 and #19 | 78,625 | +137 |
| 3206-1109 | 78,505 | #2, #3 and #4 | 78,648 | +143 |
| 2451-1077 | 78,511 | #4, #5 and #6 | 78,596 | +85 |