

U.S. DEPARTMENT OF COMMERCE
National Technical Information Service

AD-A029 127

A Review of Methods for Termination of Synthetic-Fiber Ropes

Coast Guard Res. & Development Ctr.

December 1975

247104

Report No. CG-D-29-76
Task 762515.2

AD 1029127

A REVIEW OF METHODS FOR TERMINATION
OF SYNTHETIC-FIBER ROPES

Paul B. Stinson



December 1975

Final Report

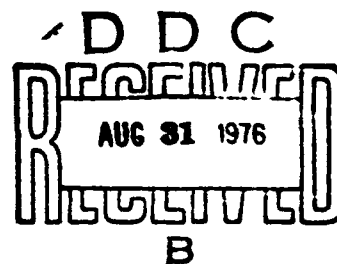

Document is available to the public through the
National Technical Information Service,
Springfield, Virginia 22161

Prepared for

DEPARTMENT OF TRANSPORTATION
UNITED STATES COAST GUARD
Office of Research and Development
Washington, D.C. 20590

REPRODUCED BY
NATIONAL TECHNICAL
INFORMATION SERVICE
U. S. DEPARTMENT OF COMMERCE
SPRINGFIELD, VA. 22161

NOTICE

This document is disseminated under the sponsorship of the Department of Transportation in the interest of information exchange. The United States Government assumes no liability for its contents or use thereof.

The United States Government does not endorse products or manufacturers. Trade or manufacturers' names appear herein solely because they are considered essential to the object of this report.

The contents of this report reflect the views of Archetypes, which is responsible for the facts and accuracy of data presented. This report does not constitute a standard, specification or regulation.

ADDITION BY	
NTIS	Wide Section <input checked="" type="checkbox"/>
DOC	Diff Section <input type="checkbox"/>
UNANNOUNCED	<input type="checkbox"/>
JUSTIFICATION	
BY	
DISTRIBUTION/AVAILABILITY CODES	
REL.	AVAIL. and/or SPECIAL
A	

Technical Report Documentation Page

1. Report No. CG-D-29-76		2. Government Accession No.		3. Recipient's Catalog No.	
4. Title and Subtitle A REVIEW OF METHODS FOR TERMINATION OF SYNTHETIC-FIBER ROPES				5. Report Date December 1975	
				6. Performing Organization Code	
7. Author(s) Paul B. Stimson				8. Performing Organization Report No.	
9. Performing Organization Name and Address Archetypes Neck Road, RFD #4 Old Lyme, CT 06371				10. Work Unit No. (TRAIS) 762515.2	
				11. Contract or Grant No. PO 81-0219-76	
12. Sponsoring Agency Name and Address Department of Transportation U.S. Coast Guard Office of Research and Development Washington, DC 20590				13. Type of Report and Period Covered Final Report	
				14. Sponsoring Agency Code	
15. Supplementary Notes The contract under which this report was submitted was under the technical supervision of the Coast Guard Research and Development Center, Groton, Connecticut 06340. R&D Center report number CGR&DC 36/75 has been assigned.					
16. Abstract Rope termination methods, ancient and modern, are reviewed, with special attention to the needs of the United States Coast Guard's Lightweight Mooring Materials Program. The mechanical features which can enhance or detract from the effectiveness of a termination are outlined. Termination methods are screened in terms of strength, life expectancy, skill requirements, cost and safety. It is concluded that for every rope construction there is at least one eye splice which measures up to all criteria very well. Thimbles, especially recent non-metallic designs, promise to protect the eyes from abrasion. It is recommended that resin-potted fittings be reserved for special applications, such as electromechanical terminations. Frictional appliances of metallic construction appear to offer no advantage to offset their inherent vulnerability to corrosion. One frictional appliance of non-metallic construction has been found, and appears to be worthy of further consideration.					
17. Key Words Terminations, cordage			18. Distribution Statement Document is available to the public through the National Technical Information Service, Springfield, Virginia 22161		
19. Security Classif. (of this report) UNCLASSIFIED		20. Security Classif. (of this page) UNCLASSIFIED		21. No. of Pages 4038	22. Price 6 4.00/2.25

ACKNOWLEDGMENTS

The author expresses his thanks to the following organizations and individuals interviewed in the course of this study, who have contributed valuable guidance and information:

- Columbian Rope Co.
F. Haas, K. Orser, J. Silver
- Cornell University
Dr. S.L. Phoenix
- Cortland Line Co.
Dr. E. Scal'
- Gould, Inc.
Dr. W. Paul
- Naval Research Laboratory
K. Ferer, R. Swenson
- Ocean Products Research, Inc.
R. Hutson, D. Richards
- Philadelphia Resins Corp.
D.P. Kollock
- Samson Cordage Works
K. Fogden
- Wall Rope Works
H.A. Hood
- Woods Hole Oceanographic Institute
P. Boutin, P. O'Malley, Dr. B. Prindle, R. Walden

TABLE OF CONTENTS

	<u>Page</u>
1.0 INTRODUCTION	1
2.0 BACKGROUND	1
3.0 MECHANICS	1
4.0 DESCRIPTIONS OF TERMINATIONS	3
5.0 TABULAR ANALYSIS OF TERMINATIONS	7
6.0 THIMBLES	7
7.0 CONCLUSIONS AND RECOMMENDATIONS	8
APPENDIX - Device for Anchoring a Textile Cable	19
BIBLIOGRAPHY	33

LIST OF FIGURES

	<u>Page</u>
1. Sailor's eye splice	11
2. Single-braid eye splice	11
3. Single-braid eye splice with tuck	11
4. Brummel splice	12
5. Unnamed single-braid splice	12
6. Unnamed single-braid splice	12
7. Modified double-braid eye splice	13
8. Uniline splice applied to double braid	13
9. Assorted resin-potted terminations	14
10. Resin-potted termination, internal detail	14
11. Nicopress sleeves applied to Phillystran	15
12. Clamping thimble	15
13. Kellems grip	15
14. Unnamed appliance	16
15. No-knot eyelet	16
16. Parafil termination	15
17. Assorted thimbles	17
18. Ocean Products Research polyurethane thimbles	17
19. Same, with molded vertex	18

1.0 INTRODUCTION

1.1 Statement of Objectives - This report reviews the state of the art in the termination of synthetic-fiber ropes, including eye splices, resin-potted fittings and frictional appliances. The mechanics of termination is reviewed in a manner which makes it possible to judge the probable effectiveness of any new termination before it is constructed and tested. The estimated strength, level of skill, unit cost and safety of each termination is tabulated.

1.2 Summary of Conclusions - It has been found that for every rope construction there is at least one eye splice which, if properly designed and skillfully applied, can attain very nearly the full breaking strength of the rope. The optimum splice is not in all cases the one best known and most commonly used. The present state of the art in resin-potted terminations is marked by an unacceptable variability in results, the need for greater skill and environmental control, and the presence of safety hazards. Among the frictional appliances, all but one were found to be of metallic construction, thereby introducing corrosion problems for which no compensating advantage could be found. The one nonmetallic appliance promises to be strong, durable, inexpensive and quickly and easily applied.

2.0 BACKGROUND

This study has been prompted by the need for optimizing the terminations of synthetic-fiber ropes for the United States Coast Guard's Lightweight Mooring Materials Program. Arbitrarily, a minimum strength equal to 90% of the rated strength of the line has been established; all hitches and bends have thus been eliminated from further consideration. Terminations designed to deal with the special properties of rubber and glass, and problems peculiar to electromechanical cables, have likewise been dismissed.

Within these boundaries, an effort has been made to gather data on all potentially useful termination designs, be they splices, resin-potted fittings or mechanical appliances. Such a study cannot claim to be exhaustive, for the potential sources are too scattered and too obscure; yet the author must confess surprise at the number of configurations previously unknown to him which have been found.

All relevant terminations are described and illustrated; then their mechanical properties, application and cost are discussed. For clarity and ease of interpretation, a tabular presentation has been chosen.

3.0 MECHANICS

A review of the mechanics of termination performance has been undertaken. This study seeks to explain the successes and failures of various configurations. The terminations described in this report have been included because they create minimum disturbance to the stress distribution in the standing part; conversely, the hundreds of candidates (including all hitches and bends, and various appliances such as wire rope clips) which have been eliminated

from further study have been ruled out primarily because they do create one or more of the disturbances described in Section 3.5. This analysis provides a basis for predicting the performance of any new and untested design.

3.1 Every termination must transfer line tension to an adjoining member by means of a zone capable of supporting shearing stress. The effective shear zone is a locus of lines parallel to the axis of the standing part. In an idealized termination having no stress concentrations, the area of the shear zone must equal the line's rated breaking strength divided by the allowable shearing stress.

3.1.1 In terminations which do not form an eye in the line, the shear zone is formed between the standing part and a terminal fitting. All of the line tension must be transferred through the shear zone.

3.1.2 In terminations which form an eye in the line, the tension branches into two equal parts around the eye, and the shear zone is formed between the standing part and its own bitter end. Only 50% of the line tension is transferred through the shear zone.

3.2 Terminations creating an intermingling of the elements forming the shear zone (e.g., most splices) create a relatively large shear area per unit length; thus their overall length may be relatively short. Terminations operating upon the line as a unit (e.g., swages) must be relatively longer, all other things being equal.

3.3 The shearing stress may be supported by means of adhesive bonding, or through friction established by forces normal to the axis of the standing part. These normal forces may be externally applied, or they may be self-induced, as they are in splices. In the latter case these forces are self-regulating, increasing as the line tension increases. The normal forces developed in splices are in all cases small compared to those ordinarily applied to swage fittings; it follows that splices are commonly longer than swages, and therefore less likely to develop stress concentrations.

3.4 In all cases except that of the resin-potted fitting, the shearing stress is supported at the periphery of some more-or-less cylindrical bundle of fibers. The laws of geometry suggest that as the size of the bundle is increased the length of the shear zone should be increased proportionately in order to support the same tensile stress. In fact, there is evidence that, in some cases at least, this relationship does not hold, and splices in larger lines must be disproportionately longer (HOOD 1975). The subject requires further study.

3.5 Any disturbance to the stress distribution in the standing part tends to weaken the termination. Sources of such disturbance are:

3.5.1 Changing the direction of a line, as in bending it around a thimble or bollard, concentrates tensile stresses in the outside of the

bend. The same effect is observed at various points in all hitches and bends, and mainly accounts for their low strength. Note, though, that in all terminations forming an eye, the bight is placed beyond the shear zone so the tension is only 50% of that of the standing part.

3.5.2 Dislocating a strand, as at the point where the tuck of a splice passes between strands, concentrates stresses in the outside of the bend in a similar manner. Tapering the tail of a splice reduces the abruptness of the dislocation and allows for transfer of a portion of the line tension below the point where the dislocations reach their maximum.

3.5.3 Random disordering of the elements of a line, as in fanning the bitter end out in a spelter socket, shortens the working length of some elements relative to the others, thus concentrating stresses.

3.5.4 Unless the termination is so designed as to secure the elements of the structure individually, creep may allow the inner members of the structure to shear relative to the outer members, thus unbalancing the stresses. Parallel filament constructions are especially vulnerable to this effect.

3.5.5 Induced stresses normal to the axis of the standing part may play a role in reducing the tensile strength. Where one member crosses another, the localized compressive stress tends to extrude material away from the stress concentration. One component of this secondary induced stress is additive to the line tension.

3.5.6 Static off-axis loading creates stress concentrations. This problem is commonly observed in sleeves, clamps and clips applied to the bight of the line. Here the load axis of the termination is dislocated by one-half the line diameter from the load axis of the standing part.

3.5.7 Dynamic off-axis loading, as may be induced by alternating drag forces, inertial forces or line vibration (strumming) tend to concentrate stresses and to aggravate any susceptibility to fatigue. Metal sleeves and sockets introduce a mass discontinuity, and unless they are fitted with carefully designed tapered boots, the flexural discontinuity concentrates stresses.

3.6 If the location of a termination can be predetermined, it is possible in some constructions to reinforce the structure of the rope during manufacture so as to reduce the stresses in the termination. An example of this is Cortland Line Company's Cormar(R) construction.

4.0 DESCRIPTIONS OF TERMINATIONS

4.1 Eye Splices - All eye splices function by means of friction developed between the standing part and the tail. The normal forces developing that friction are self-regulating, increasing with increasing tension.

All traditional eye splices disturb the lay of the rope to some extent and must be tapered in order to minimize that disturbance.

There is a new class of splices in which the tail overlays the standing part instead of entering the rope structure. In these cases the tail imposes only a hoop stress on the standing part, and its weakening effect should be minimal. See the Uniline splice, 4.1.5.2. The same splice applied to a double braid is described in 4.1.4.3 and illustrated in Figure 8. An unnamed splice, devised by the author, operates in the same manner on hollow braids. It is described in 4.1.3.5 and shown in Figure 5.

4.1.1 Splices applicable to laid ropes: ASHLEY (1944) describes and illustrates nearly one hundred eye splices applicable to laid ropes. Closer study shows them to be variants of a few principal types, and even these principal types are in most cases so similar in their effect that a detailed discussion must be considered beyond the scope of this report. Many of the variants appear to have been spawned by a quest for neatness and compactness; others seem to be the results of a game, in which the goal is simply proliferation. The interested reader is referred to Ashley for further details.

The sailor's eye splice (Figure 1) is by far the most widely known of this class and is representative in all respects. Four full and two taper tucks are normally specified for synthetic-fiber ropes; a measurable strength increase can be gained by finer tapering. The tails of the final tuck must not be trimmed too close.

4.1.2 Splice applicable to 8-strand plaited rope -

4.1.2.1 Conventional (See illustrated instructions in appendix.) - The bitter end is unlaid, formed into a bight, then woven back through the strands of the standing part, forming in effect a 16-strand plait. Four full and two taper tucks are normally called for, and the tails must not be trimmed too close.

4.1.3 Splices applicable to hollow braided ropes - All the splices in this section function by either tucking the tail into the standing part or the standing part into the tail, or some combination of these. Any intrusion into the standing part alters the lay and tends to weaken the splice; careful tapering minimizes that weakening. Attention is called to the unnamed splice described in 4.1.3.5, in which the lay is not disturbed.

4.1.3.1 Conventional (Figure 2) - The lay is separated at an appropriate point and the bitter end is inserted, usually with the aid of a special fid. At an appropriate point farther down the standing part the bitter end is drawn out, tapered, then drawn back in. This splice may drift when the standing part is slack, so is normally stitched with sail twine or rope yarns. The following variants on this splice need not be stitched.

4.1.3.2 Conventional with tuck (Figure 3) - The tuck is in a low-stress region of the splice, so causes no strength reduction.

4.1.3.3 Brummell splice (Figure 4) - More elaborate than the above; perhaps needlessly so. In effect both ends are tucked through each other; if the far end is not accessible, the line can be "fooled" into forming a topological equivalent by literally turning a portion of the braid inside out.

4.1.3.4 Cortland splice - This splice is akin to the foregoing. Its application is at present limited to very small diameters (fishing lines), but it could be used on larger sizes.

4.1.3.5 Unnamed splice (Figure 5) - Akin to the Cortland splice, but omits the final tuck of the bitter end into the standing part; therefore it does not disturb the lay. It is functionally similar to the Uniline splice (4.1.5.2). The tail may be married to the standing part with marline, or may be stitched.

4.1.3.6 Unnamed splice (Figure 6) - An ill-conceived attempt to prevent the eye from loosening when slack. Creates severe stress concentration where the tail exits from and reenters the standing part.

4.1.4 Splices applicable to double-braided ropes -

4.1.4.1 Samson splice - Unusually neat in appearance, but relatively intricate to form. May be appreciably weakened unless balance between core and cover is carefully maintained during splicing; imbalance is difficult to detect by inspection.

4.1.4.2 Samson splice (Modified Figure 7) - Useful where core and cover are of markedly different materials, so that the cover is not functioning as a strength member.

4.1.4.3 Uniline splice applied to double braid (Figure 8) - See 4.1.5.2 following. May prove to be a superior method of terminating double braid, but requires test and evaluation. The designer of the Uniline splice cautions (HOOD 1975) that it has not been optimized for constructions other than Uniline, and the spacing of the wraps must be modified to match the higher stretch of other constructions.

4.1.5 Splices applicable to parallel-filament ropes -

4.1.5.1 Nolaro^(R) splice - Developed by Columbian Rope Co. Relatively quick and easy to form.

4.1.5.2 Uniline^(R) splice - Developed by Wall Rope Works. Sounds difficult to make on first reading, but really is not. Appears (along with 4.1.3.5, Figure 5) to meet the criteria of Section 3, Mechanics, better than any other termination found in the course of this study. Applicable to constructions other than parallel-filament; in fact to any construction which can be combed out to form four bundles.

4.1.5.3 Morieras splice (See U.S. Pat. 3,411,400 in appendix) - Probably requires exceptionally long taper of tail in order to attain acceptable performance.

4.2 Resin-potted terminations - These fittings are analogous to and derived from the zinc-poured spelter sockets which have long been employed for the termination of wire ropes. Some resin-potted fittings are finding application in the field at the time of this writing, but the variety of designs is so wide that it seems impractical to go beyond the illustrating of a few representative types at this time. (See Figures 9 and 10.) Some thoroughly successful terminations have been made, but many workers report a scatter in their test results which is much wider than that ordinarily achieved with eye splices. Resin potting must therefore be regarded as being in an experimental state. Some of the problems are:

4.2.1 The elastic properties of the line, the resin and the socket are ordinarily quite different from one another, so a careful study of their interaction is required.

4.2.2 The insertion of the bitter end into the socket can be expected to disturb the structure of the line appreciably. See 3.5.3. Some workers have resorted to extreme measures to ease this problem, such as suspending individual weights from the yarns during preparation for potting (SWENSON 1975).

4.2.3 The inclusion of any air void in the socket creates a stress concentration, which may be severe. Evacuation of the assembly after pouring has been resorted to by some workers (HUTSON 1975).

4.2.4 Inaccurate metering or inadequate mixing of the resin leads to inconsistent results.

4.2.5 Control of temperature and humidity during application is usually required.

4.2.6 Exposure to water, especially water under high pressure, affects the properties of some resins (FERER 1973).

For the most part, these deficiencies are detectable only by means of destructive testing. Any resin-potted system under consideration must be carefully evaluated in the light of the above.

4.3 Frictional appliances - There are many mechanical devices designed to grip a line and transfer stress by means of friction. Most of these were designed to be applied to wire rope, but some are applicable to synthetic fibers. Most such devices have a working length equal to only a few line diameters, so they must be applied with relatively large normal forces in order to transfer the stress through a relatively small area. Frictional appliances which have been successfully applied to synthetic fiber ropes are:

4.3.1 Swaged sleeves - Most frequently applied to lines of very small diameter but Philadelphia Resins Corp. claims acceptable results on Kevlar(R) lines up to 200,000 lbs. rated breaking strength (Figure 11). The placement and the sequence of the swaging actions on the sleeves may affect the results. It has been suggested (RIEWALD et al 1975) that long-term loading should be limited to 65% of ultimate because of stress concentrations.

4.3.2 Aeroquip Ropelock^(R) (Figure 12) - Differs from most thimble configurations in that the loop around the thimble is under full line tension. Probably intended only for service as a temporary stopper.

4.3.3 Kellems grip (Figure 13) - Has most of the desirable properties of the Uniline splice (4.1.5.2), but is metallic, therefore subject to corrosion, and does not secure the ends of the rope structure individually. (See 3.6.4.)

4.3.4 Unnamed appliance (Figure 14) - Structurally and functionally similar to the foregoing, but nonmetallic. There are conflicting claims to the invention and introduction of this appliance in the U.S. It is reliably reported to have been in use in Europe for 20 years or more.

4.3.5 No-knot eyelet (Figure 15) - Applicable to hollow braids. Supplied in very small sizes for application to fishing lines, but potentially useful in larger sizes.

4.3.6 Parafil termination (Figure 16) - Contains a conical plug which is driven into the axis of the line. Marketed by British Ropes, Ltd.

5.0 TABULAR ANALYSIS OF TERMINATIONS

In this table, all terminations described in Section 4.0 are screened in terms of several relevant properties. An earnest effort was made to produce the results of the table in numerical form so that a figure of merit could be derived for each candidate. It has proved impracticable to produce a scale of values which can equate such divergent properties as strength and cost. There is, for example, a serious danger of assigning a superior figure of merit to a termination with a serious mechanical defect, on the ground that it is cheap and easy to apply.

The data entered into the table are, of necessity, a subtle mixture of fact and opinion. There is no body of unified information from which truly objective conclusions might be drawn.

6.0 THIMBLES

For those terminations which form an eye in the line, some protection for that eye is usually necessary. Thimbles of many forms have been developed over the years (Figure 17); recent advances in the strength of synthetic-fiber cordage makes it necessary to reconsider the design. Common galvanized thimbles designed for use with manila rope deform severely when stressed to the breaking point of the synthetics. Cast bronze thimbles of the Newco pattern are far stronger and positively prevent the eye from slipping off the thimble; but they are all too frequently misapplied, being shackled directly to common galvanized hardware for use in sea water. Galvanized thimbles designated for service with wire rope are generally satisfactory for use with the older synthetics, but may deform when stressed to the breaking point of Kevlar^(R). Tubular thimbles of polyurethane (Figures 18 and 19) have been introduced recently by Ocean Products Research, Inc., and appear to be successful in their resistance to abrasion. Their design should be considered carefully for each application to insure that the plastic does

not extrude in the way of the shackle pin. If necessary, the shackle pin might be specially contoured to provide a greater bearing area.

The several types of conventional thimbles are available from a variety of competing manufacturers in a wide range of sizes. Since their prices as a function of size and type are itemized in all the standard marine hardware catalogs, it is beyond the scope of this report to review them here. Two uncommon types are singled out for mention of cost information. The Newco costs approximately \$4.00 in the 1/2-inch size. The Ocean Products Research thimble costs, in the 1/2-inch size, \$2.50 for the tubular thimble and an additional \$2.00 for having it molded onto the eye.

7.0 CONCLUSIONS AND RECOMMENDATIONS

1. Cordage experts consulted in the course of this study were nearly unanimous in their conclusion that no terminal appliance is superior to a well designed, properly made eye splice. For every type of rope construction, there is a splice which, if properly tapered, can hold essentially the full rated strength of the rope. Note, though, that the optimum splice is not in all cases the one best known and most commonly used.

2. While the level of skill demanded of a splicer is not great, a sense of craftsmanship is essential. A sloppy, uneven splice is measurably weaker than a well made one. The importance of proper tapering cannot be overemphasized. The time required, even for the most elaborate splices, is not great: a competent worker can produce splices at the rate of four to twelve per hour, depending upon the design of the splice.

3. The need for tapering may be eliminated by the use of splices 4.1.3.5 (believed to be the original design of this author) and 4.1.5.2 (the Uniline splice). These splices do not reenter and disturb the lay of the standing part. The former is applicable only to the single hollow-braid construction; the latter is designed for use on Wall Rope's Uniline(R), but may be adaptable to others. The level of skill required for successfully applying these splices is probably less than that for the traditional splices.

4. It is recommended that the use of resin-potted terminations be confined to special applications which preclude other methods. Successful resin-potted terminations have been made, but the elaborate setup requirements, the slowness of cure, the handling hazards inherent in epoxy resins and the difficulties of quality assurance score heavily against this approach.

5. The frictional appliance described in paragraph 4.3.4, which is nonmetallic, is worthy of serious consideration. To the author's knowledge it has not yet found widespread application, but it appears to meet the theoretical criteria very well. It is probably as quick and foolproof in its application as any termination can be.

The other frictional appliances do not appear to offer any advantages which offset the introduction of new metallurgical problems.

EVALUATION OF TERMINATIONS

	Sailor's Eye Splice 4.1.1, Figure 1	Eight-strand Eye 4.1.2.1, Appendix	Hollow-braid Eyes 4.1.3.1, Figures 2,3,4 4.1.3.2 4.1.3.3 & Appendix 4.1.3.4	Unnamed Hollow-braid Eye 4.1.3.5, Figure 5	Unnamed Hollow-braid Eye 4.1.3.6, Figure 6	Samson Double-braid Eye 4.1.4.1, Appendix	Samson Eye, Modified 4.1.4.2, Figure 7
1. Corrosion resistance							
2. Abrasion resistance	b	b	b	c	b	b	b
3. Impact resistance							
4. Strength of fixture							
5. Strength of line with termination applied	f	f	f	e	g	h	f
6. Service conditions							
7. Service life							
8. Skill required for application	k	k	k	k	k	l	k
9. Material or parts requires							
10. Special facilities or conditions							
11. Size limitations							
12. Safety aspects of application and use							
13. Unit cost	j	j	j	j	j	j	j
14. Cost of special fixtures							
15. Does termination form an eye? (§3.1)	yes	yes	yes	yes	yes	yes	yes
16. Disturbances to stress distribution:							
A. Bending in a high-stress region (§3.5.1)							
B. Strand dislocation (§3.5.2)	k	k	k	j	l	k	k
C. Random disordering (§3.5.3)							
D. Unbalance due to creep (§3.5.4)							
E. Localized compressive stress (§3.5.5)							
F. Static off-axis loading (§3.5.6)							
G. Dynamic off-axis loading (§3.5.7)							

KEY: (Blank indicates no problem or no special consideration)

- a. Subject to same limitation as other metallic components in sea water
- b. No more vulnerable than standing part
- c. Extra protection advised
- d. Avoid off-axis loading
- e. Highest possible strength
- f. Slightly weaker than standing part
- g. Significantly weaker than standing part
- h. Variable

- i. In
- j. Sl
- k. No
- l. Co
- m. Me
- n. Sw
- o. Gen

4.1.3.5, Figure 5		4.1.3.6, Figure 6		4.1.4.1, Appendix		4.1.4.2, Figure 7		4.1.4.3, Figure 8		4.1.5.1, Appendix		4.1.5.2, Appendix		4.1.5.3, Appendix		4.2, Figures 9 & 10		4.3, Figure 11		4.3.2, Figure 12		4.3.3, Figure 13		4.3.4, Figure 14		4.3.5, Figure 15		4.3.6, Figure 16	
c	b	b	b	b	c	b	c	a	a	a	a	a	a	a	a	a	a	a	a	a	a	a	a	a	a	a	a	a	a
e	g	h	f	e	f	e	h	i	i	g	e	e	e	e	e	e	e	e	e	e	e	e	e	e	e	e	e	e	e
k	k	l	k	k	k	k	l	k	k	j	j	j	j	j	j	j	j	j	j	j	j	j	j	j	j	j	j	j	j
j	j	j	j	j	j	j	k	k	k	k	k	k	k	k	k	k	k	k	k	k	k	k	k	k	k	k	k	k	k
yes	yes	yes	yes	yes	yes	yes	no	yes	no	no	no	no	no	no	no	no	no	no	no	no	no	no	no	no	no	no	no	no	no
j	l	k	k	j	k	j	h	h	h	h	h	h	h	h	h	h	h	h	h	h	h	h	h	h	h	h	h	h	h

i. Insufficient data

j. Slight

k. Moderate

l. Considerable

m. Metering and mixing apparatus, temperature and humidity controls, air evacuating apparatus

n. Swaging apparatus with appropriate dies

o. Generally limited to smaller sizes



Figure 1. Sailor's eye splice.

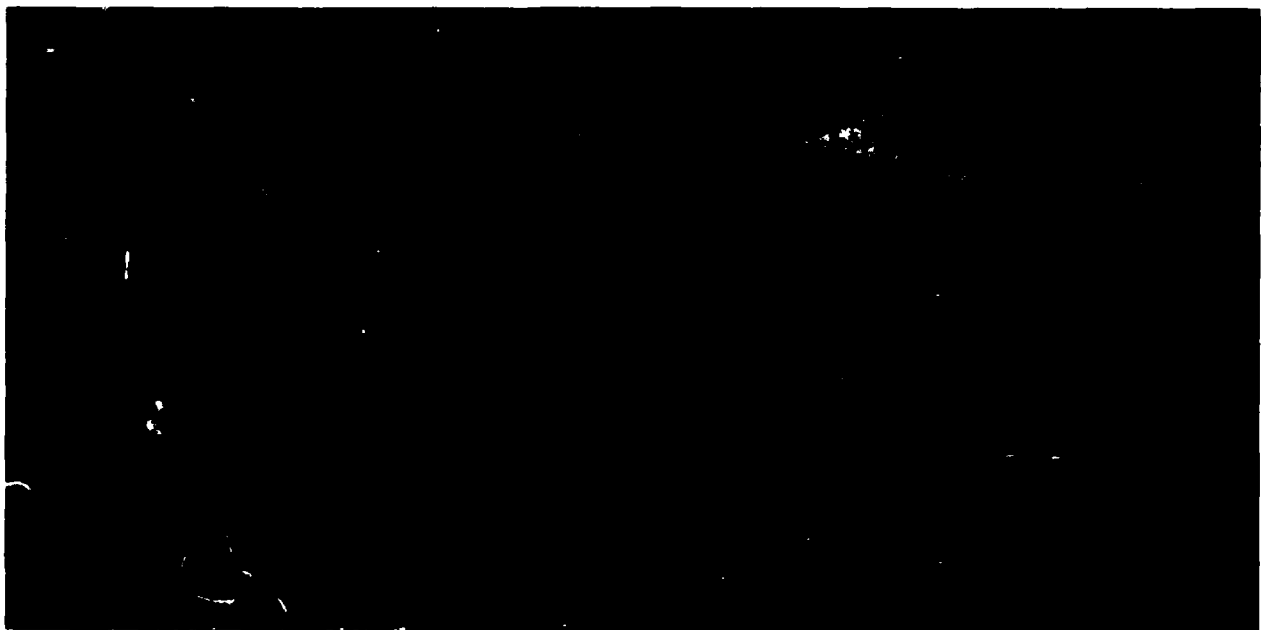

Figure 2 (top). Single-braid eye splice.
Figure 3 (bottom). Single-braid eye splice with tuck.



Figure 4 (top). Brummel splice.
Figure 6 (bottom). Unnamed single-braid splice.



Figure 5. Unnamed single-braid splice.

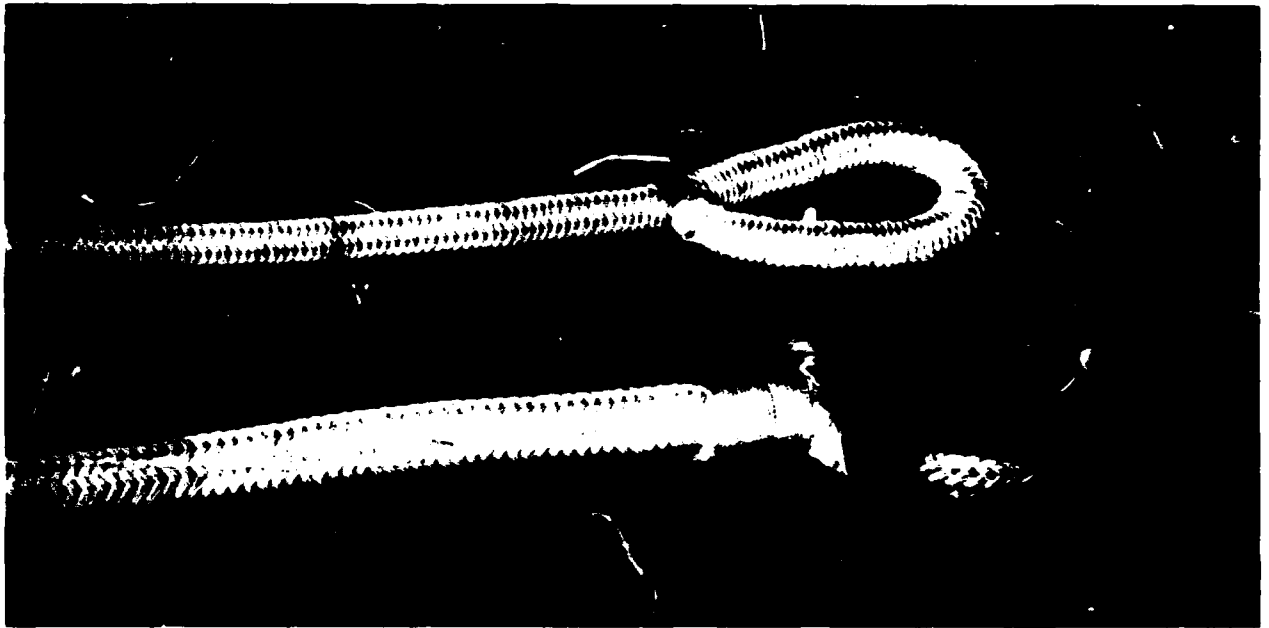

Figure 7. Modified double-braid eye splice.

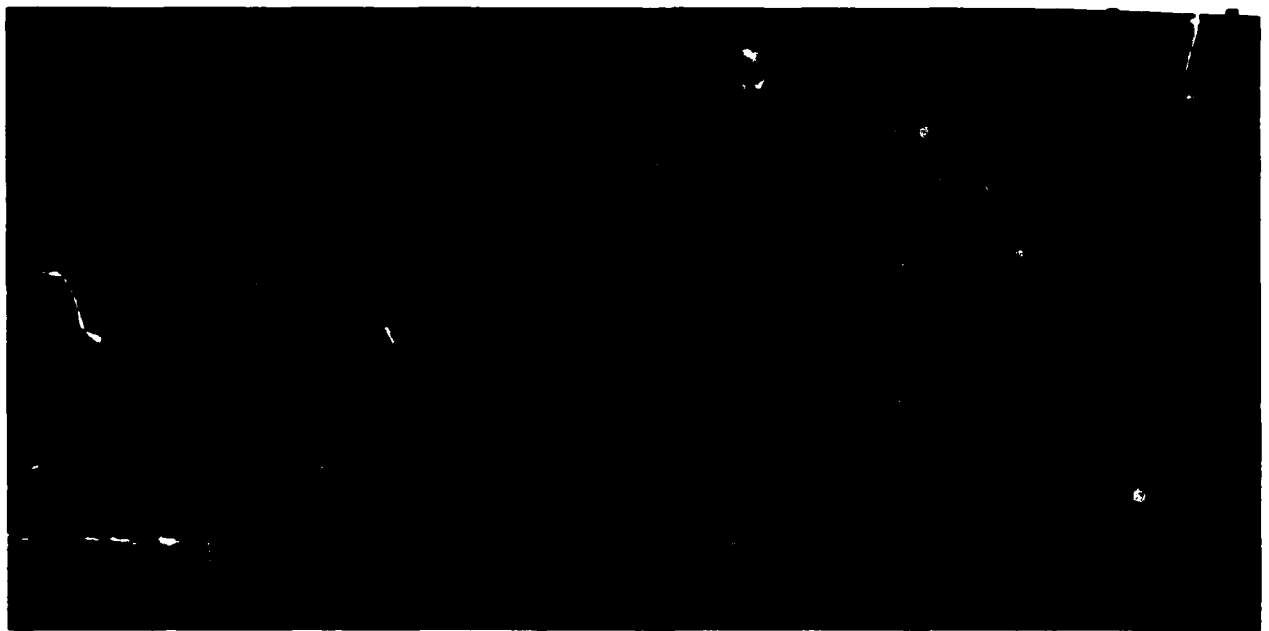

Figure 8. Unilire splice applied to double braid.

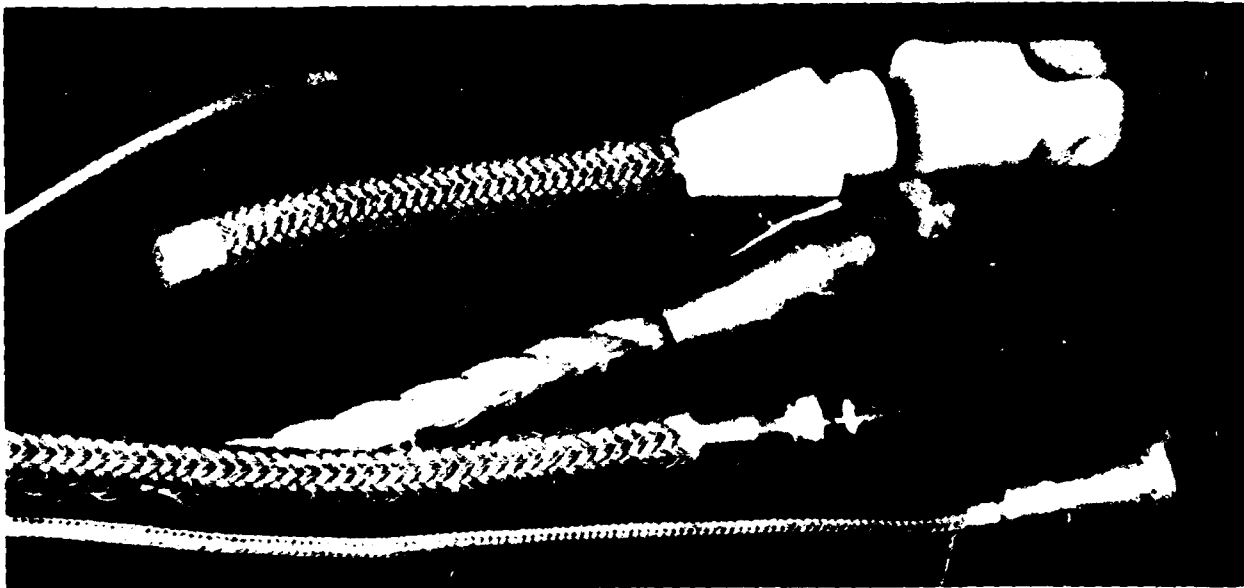

Figure 9. Assorted resin-potted terminations.

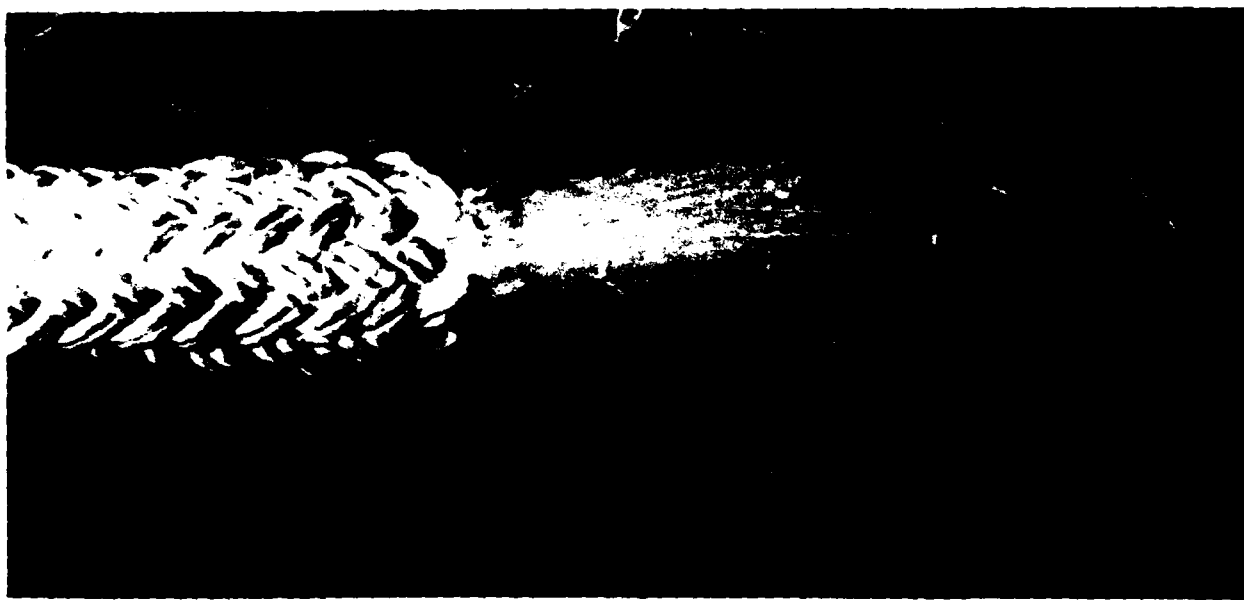

Figure 10. Resin-potted termination, internal detail.



Figure 11. Nicopress sleeves applied to Phillystran.



Figure 16 (top). Parafil termination.
Figure 12 (middle). Clamping thimble.
Figure 13 (bottom). Kellems grip.

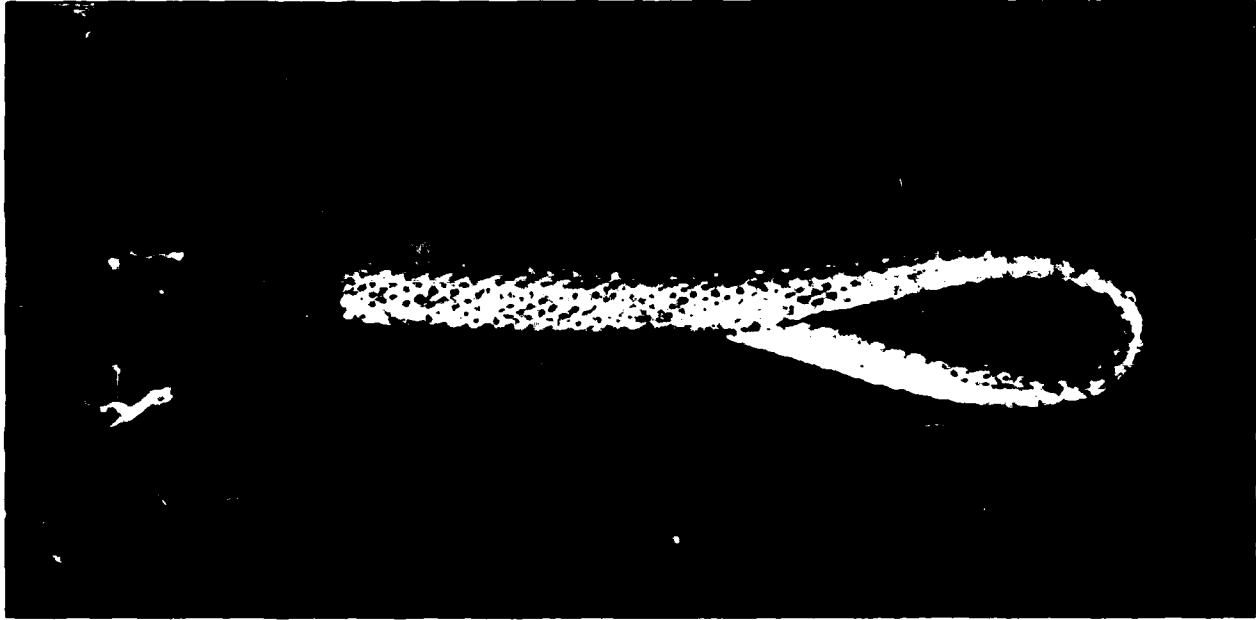

Figure 14. Unnamed appliance.

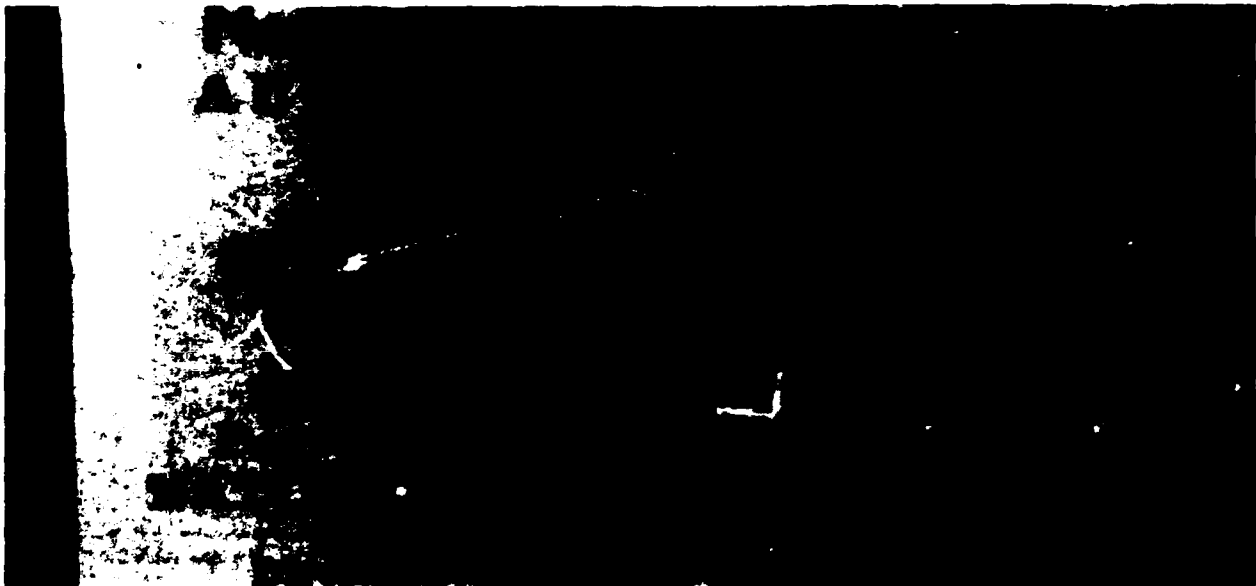

Figure 15. No-knot eyelet.



Figure 17. Assorted thimbles.



Figure 18. Ocean Products Research polyurethane thimbles.

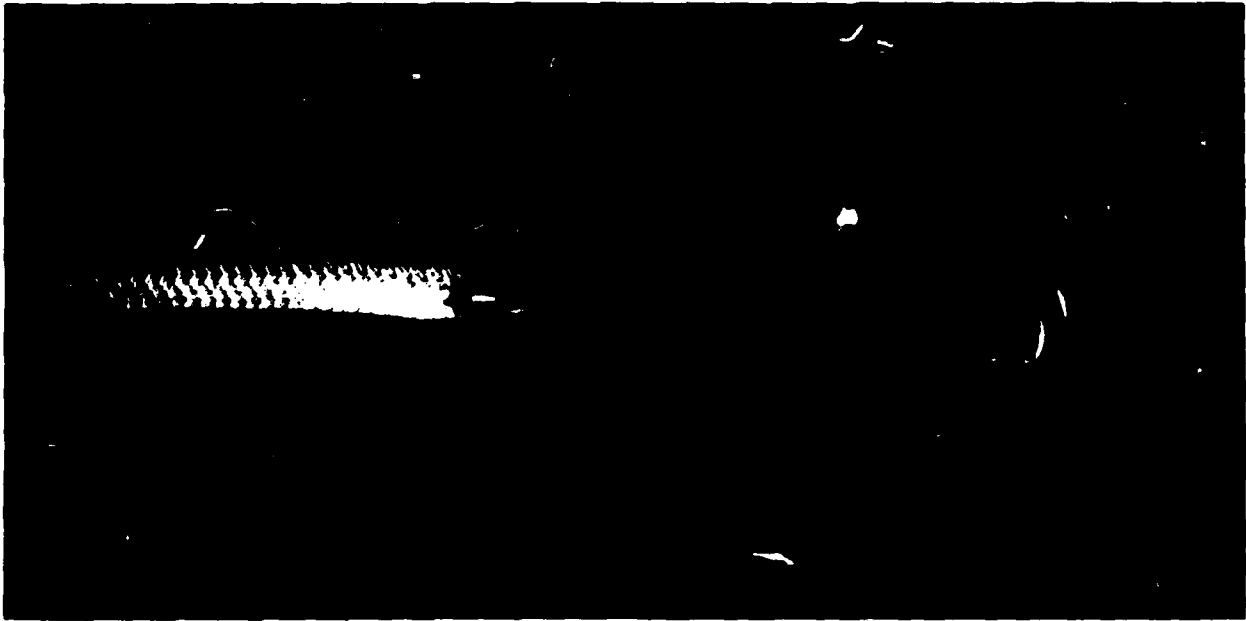

Figure 19. Ocean Products Research polyurethane thimbles,
with molded vertex.

APPENDIX
DEVICE FOR ANCHORING A TEXTILE CABLE

Nov. 12, 1953

G. MORIERAS

3,409,951

DEVICE FOR ANCHORING A TEXTILE CABLE

Filed Nov. 7, 1956

2 Sheets-Sheet 1

FIG. 1.

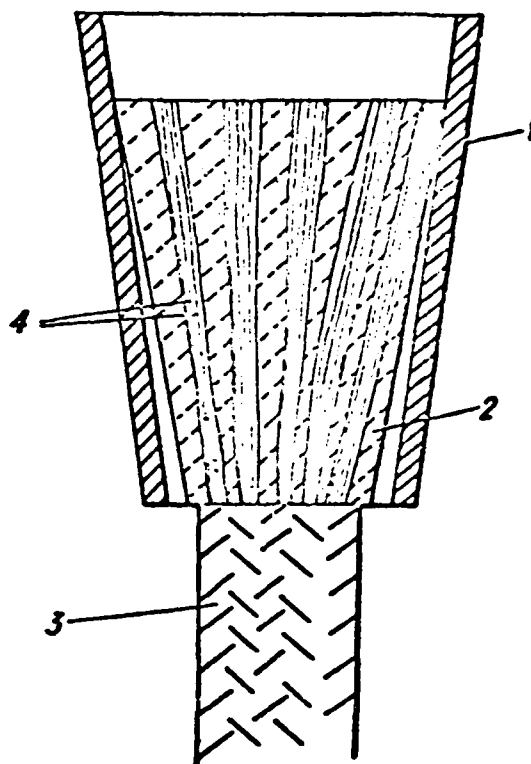

Gilbert Morieras
Inventor
By *Cushman, Deily & Cushman*
Attorneys

Preceding page blank

Nov. 12, 1968

G. MORIERAS

3,409,951

DEVICE FOR ANCHORING A TEXTILE CABLE

Filed Nov. 7, 1966

2 Sheets-Sheet 2

FIG. 2.

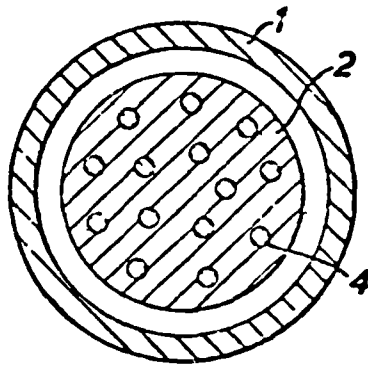

FIG. 3.

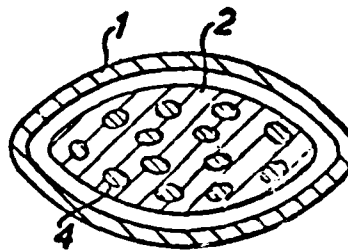

FIG. 4.

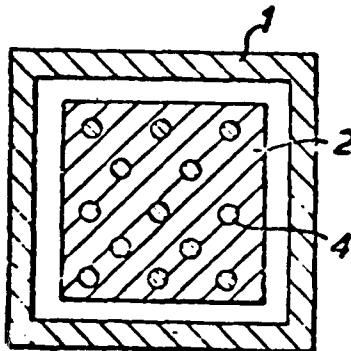
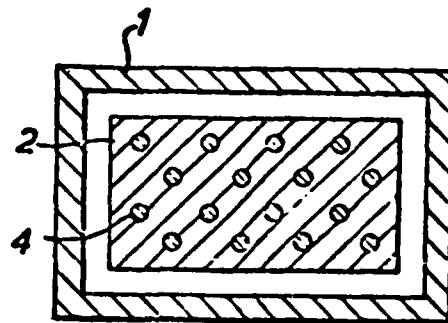

FIG. 5.



INVENTOR
GILBERT MORIERAS

BY *Lawrence D. ...*
ATTORNEYS

C O P Y

UNITED STATES PATENT OFFICE
3,409,951
Patented Nov. 12, 1968

DEVICE FOR ANCHORING A TEXTILE CABLE
Gilbert Morieras, Lyon, France, assignor to Societe
Rhodiaceta, Paris, France, a French body corporate
Filed Nov. 7, 1966, Ser. No. 592,610
Claims priority, application France, Nov. 15, 1965,
33,390
15 Claims. (Cl. 24--123)

ABSTRACT OF THE DISCLOSURE

Anchoring device for a textile cable under tension comprising a core formed by a bundle of parallel filaments and an external envelope covering the core. The device is constituted exteriorly by a rigid sleeve of tapering form and interiorly by a bung also of tapering form which has a common directrix with the sleeve and in which the end of the cable is fixed in any appropriate way. The interior apical angle of the sleeve is less than the apical angle of the bung. The device is particularly advantageous for anchoring cables made of synthetic textile materials such as polyamides, polyesters and polyolefins.

This invention relates to an anchoring device, that is to say a device for attachment to a fixed point, of a textile article operating under tension; such articles include cords, cables, straps, slings, etc., which for simplicity will be described by the single term "cable" in the following description.

For some years metallic cables have to some extent been replaced by cables made from synthetic textile filaments, for example polyamide or polyester filaments. Thus some textile cables have been made which, for a given weight per metre, have a higher resistance to break than have steel cables, and this should allow them to be used advantageously as traction elements (e.g. as cables for masts, catenaries, buoys, ships' slings, etc.). Unfortunately textile cables have not undergone such development in this field of application, largely as the result of the absence of suitable means for anchoring them.

To form an anchoring device with a steel cable, the wires at the end of the cable are untwisted and each wire is individually folded into the shape of a loop; the assembly of wires is then opened up and placed in a sleeve the internal shape of which is generally that of a truncated cone, this sleeve serving as a mould, and finally a low melting point alloy of lower hardness and modulus than the steel comprising the wires of the cable is cast onto the folded wires. After cooling, a compact truncated

C O P Y

3,409,951

conical mass is thus obtained, called a "bung" which has been cast directly into the anchoring sleeve which serves as a mould. In this way the bung when under tension on the one hand does not damage the cable and on the other hand is sufficiently firm not to slip out of the sleeve.

Before this technique can be applied to textile cables, it is necessary to have a casting material which at one and the same time has good adhesion and excellent chemical inertness towards the filaments comprising the cable, a casting and/or polymerisation temperature which does not cause significant degradation of the filaments, sufficient hardness not to slip out of the sleeve when heavy tension is applied and finally a sufficiently low hardness and modulus not to degrade the filaments when subjected to transverse forces.

To satisfy these requirements, which are in some respects incompatible, synthetic resins are used which polymerise at a low temperature, for example under the action of a catalyst, such for example as epoxy resins. However up to the present textile cables fitted with bungs produced by the conventional method of making bungs for steel cables have not been satisfactory, because they cause a strength loss of between 15 and 50% in the area of the bung. (The loss in strength of a cable is given by the difference between the actual strength of the cable and its practical strength as measured with the cable fixed at one of its ends by means of a bung.)

Up to the present bungs produced in practice fit the sleeve tightly, at least at the narrowest point. This arrangement would appear to lead to the optimum fit of the bung (and hence the best retention of the cable through compression) whilst avoiding an elongation stress on the bung. It has now been found that, on the contrary, a bung which is free to stretch within its sleeve can give stronger anchorage than do the earlier techniques.

The arrangement of the invention successfully mitigates the disadvantages of the earlier means. This new arrangement consists externally of a sleeve of a rigid material, for example metal, defining a truncated substantially tapering channel, and internally of a truncated substantially tapering coaxial bung, made of resin, having a common directrix with the channel of the sleeve, into which the end of the cable is fixed by an appropriate method, the arrangement being characterised by the fact that the angle at the top of the channel of the sleeve is less than the angle at the top of the bung. The difference between the two angles is preferably less than five degrees and is advantageously about one degree.

In practice the internal forms of the sleeve and of the bung will be of very simple shapes, such as truncated cones of circular or elliptical cross-section, truncated pyramids, truncated ovoids, or sand mounds.

The invention is illustrated in the accompanying drawings in which FIGURE 1 is a schematic cross-section of an advantageous embodiment of the invention, in which 1 indicates the sleeve, 2 the resin bung, and 3 the

C O P Y

3,409,951

cable consisting of textile filaments 4, whose opened-out ends are fixed into the bung. FIGURES 2 to 5 are schematic cross-sections of alternative embodiments of the invention.

With the device of the invention, the textile material stretches when subjected to a tensile stress, progressively causing the bung to rest against an increasing fraction of the internal surface of the sleeve as the tension increases. In this way, contrary to what takes place with the earlier bungs, there is no sharp discontinuity between the textile material and the resin since the latter can move freely. Thus the tensile stress is absorbed by an increasingly large part of the bung, which eventually is supported, from top to bottom, by the whole of the surface of the sleeve. Furthermore, transverse forces are a maximum at the top of the bung, that is to say where the tensile stress is a minimum, and conversely the compressive stress is low at the narrow end of the bung where the tensile stress is highest. Thus the cable is not weakened, and does not break at the narrow end of the bung.

Finally, the device of the invention makes it possible for the axis of the bung in the sleeve and the axis of tension of the cable to be automatically made to coincide even if the bung has not been strictly cast around the said axis of the cable.

Resins normally used in this field of application, for example epoxy resins and polyesters, may be used for the manufacture of the bung. These resins may with advantage be reinforced by incorporating various materials such as textile fibres, especially glass fibres, whilst the resin is liquid.

The device of the invention is particularly advantageous for anchoring cables made of synthetic textile materials (polyamides, polyesters, polyolefines, etc.) and especially for cables consisting of a core formed by a bundle of elementary filaments which are parallel to one another and are only slightly twisted or not twisted at all, and at least one external cover which is generally plaited, especially the cables whose manufacture is described in our French Patents Nos. 1,327,110, and 1,354,961.

The following examples illustrate the invention. An expert technician could easily introduce modifications, for example by simple substitution of equivalent materials, without going outside the scope of the invention.

Example 1

99 ends of continuous polyhexamethylene adipamide yarns each of 30,000 deniers/5,000 strands and of 40 turns/metre Z (right hand) twist, are passed in parallel, in the form of a web, through a tank containing a self-vulcanising enriched rubber latex. On leaving the tank, the impregnated ends are carried vertically upwards and are then passed through a calibrating die of diameter close to the final diameter of the cable. The drying of the binder is started at the same time.

C O P Y

3,409,951

The combination of ends is again impregnated with fresh binder, and then passes into a plaiting machine comprising 24 spindles, each fed by one continuous filament end, again of polyhexamethylene adipamide, of gauge 15,000 deniers/900 strands, twist 70 turns/metre (12 ends with S (left-hand) twist and 12 with Z twist.)

The assembly is then passed into a coloured polyvinyl chloride composition, and thereafter into a conical elastic sleeve whose smallest diameter substantially corresponds to the diameter of the finished cable.

The cable continuously passes through a tunnel oven in which the temperature rises progressively from 60 to 180° C., remaining in the oven for about 5 minutes.

The finished cable has a diameter of 26 mm. and weighs approximately 634g./m.

A 2.70 m. sample is cut from this cable, and its two ends are untwisted over a length of about 25 cm. The component ends are opened out into contiguous conical webs under uniform tension. A truncated conical mould is filled with an epoxy resin composition of trade name ARALDITE, consisting of the following parts by weight:

	Parts
Epoxy resin (CY 248)	100
Catalyst (HY 965 and 966):	
Polyamide	39
Polyamide and polyamine	1

After polymerisation, each bung has the shape of a truncated cone, 16 cm. high of apical angle about 16°.

Each bung is placed in a metal sleeve of apical angle 15°. The cable is subjected to a tensile stress by means of a tensometer until it breaks. This takes place at a load of 20.3 metric tons and the cable breaks in the middle of the sample.

Example 2

The same cable as in Example 1 is used but the bungs are produced by the earlier conventional method, opening out and spreading out the ends of the cable in the same way and casting the same resin composition into a 16 cm. high sleeve having a top angle of 15° and a base diameter of 40 mm. The cable, fixed at its two ends, is broken by means of the same tensometer as before. The break takes place within the bung at a load of 13.4 metric tons. The comparison between Examples 1 and 2 perfectly illustrates the advance achieved by the device of the invention.

C O P Y

3,409,951

Example 3

Example 1 is repeated with only a single change, namely that the core filaments of polyhexamethylene adipamide are replaced by continuous polyethylene terephthalate filaments.

Breakage takes place in the middle of the sample, at 17.8 metric tons.

Example 4

Example 2 is repeated with the same cable as in Example 3. Breakage takes place within the bung at a load of 13.2 metric tons.

I claim:

1. Device for anchoring a textile cable operating under tension, which comprises a core formed by a bundle of substantially parallel elementary filaments and at least one external envelop covering the said core, the device being constituted exteriorly by a rigid sleeve of generally tapering form, and interiorly by a resin bung, also of generally tapering form which has a common directrix with the sleeve and in which is fixed in any appropriate way the end of the cable, characterised in that the interior apical angle of the sleeve is less than the apical angle of the bung.
2. Anchoring device according to claim 1, in which the difference between the two apical angles is less than 5° .
3. Anchoring device according to claim 2, in which the difference is close to 1° .
4. Textile element equipped at at least one end with an anchoring device comprising in combination a rigid sleeve defining a truncated tapering channel, and contained within it a truncated tapering resin bung in which the end of the cable is so fixed that the free part of the cable emerges from its narrow end, the bung being substantially coaxial and having a common directrix with the channel of the sleeve and the interior apical angle of the sleeve being less than the apical angle of the bung.
5. Textile elements according to claim 4, in which the difference between the two apical angles is less than 5° .
6. Textile elements according to claim 5, in which the difference is less than 1° .
7. Textile elements according to claim 5, consisting essentially of a synthetic polymer.

C O P Y

3,409,951

8. Anchoring device according to claim 2 in which the interior of the sleeve and the bung have the form of a truncated cone of circular cross-section.

9. Anchoring device according to claim 2 in which the interior of the sleeve and the bung have the form of a truncated cone of elliptical cross-section.

10. Anchoring device according to claim 2 in which the interior of the sleeve and the bung have the form of a truncated pyramid.

11. Anchoring device according to claim 2 in which the interior of the sleeve and the bung have the form of a sand mound.

12. Textile elements according to claim 5 in which the interior of the sleeve and the bung have the form of a truncated cone of circular cross-section.

13. Textile elements according to claim 5 in which the interior of the sleeve and the bung have the form of a truncated cone of elliptical cross-section.

14. Textile elements according to claim 5 in which the interior of the sleeve and the bung have the form of a truncated pyramid.

15. Textile elements according to claim 5 in which the interior and the sleeve of the bung have the form a sand mound.

References Cited

UNITED STATES PATENTS

2,048,292	7/1936	Rau	24-123.1
3,263,289	8/1966	Lagarde.....	24-123.2
3,283,380	11/1966	Gassner	24-123.2

BERNARD A. GELAK, Primary Examiner.

Nov. 19, 1968

G. MORIERAS ET AL

3,411,400

SPLICED LOOP AND METHOD OF FORMATION THEREOF

Filed Sept. 6, 1967

2 Sheets-Sheet 1

FIG. 1

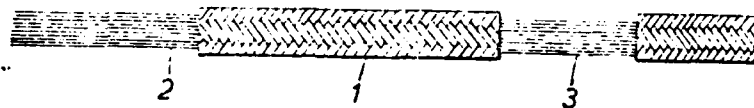
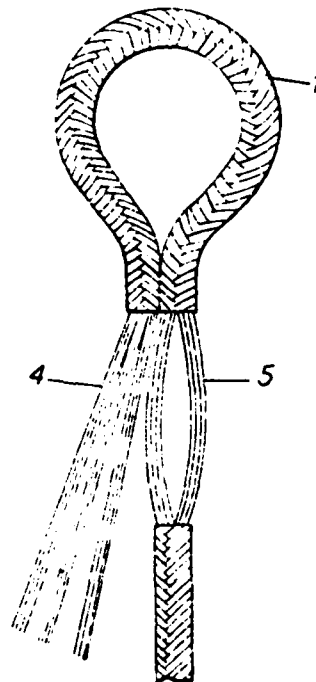

FIG. 2



FIG. 3



29

Inventors
Gilbert Morieras
Michel Luc de Lanoux
By *Cushman, Darby & Cushman*
Attorneys

Nov. 19, 1968

G. MORIERAS ET AL

3,411,400

SPLICED LOOP AND METHOD OF FORMATION THEREOF

Filed Sept. 1, 1967

2 Sheets-Sheet 2

FIG. 4.

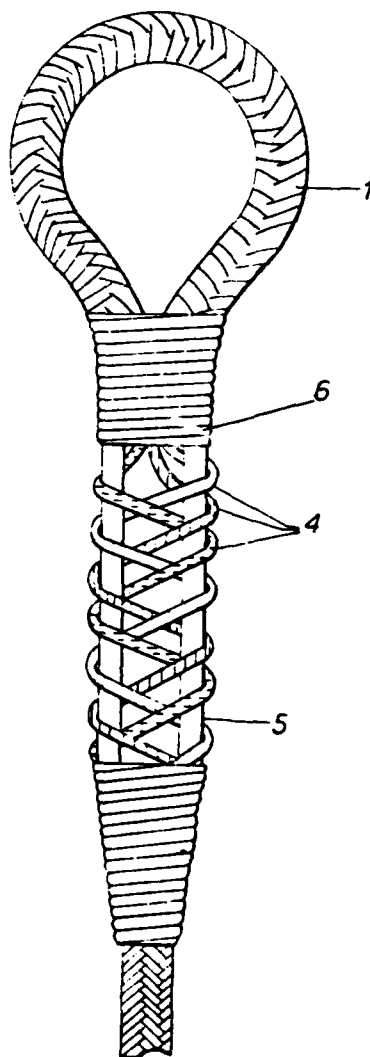

Inventors
Helbert Morieras
Michel Luc de Lanoux
By *Cushman, Darby & Cushman*
Attorneys

1

2

3,411,400
**SPliced LOOP AND METHOD OF
 FORMATION THEREOF**

Gilbert Morieras and Michel Sere de Lanauze, Lyon,
 France, assignors to Societe Rhodiacaeta
 Filed Sept. 6, 1967, Ser. No. 665,793
 Claims priority, application France, Sept. 20, 1966,
 77,007

8 Claims. (Cl. 87-3)

ABSTRACT OF THE DISCLOSURE

The invention describes a spliced loop in a textile rope, and method of making such a loop, in which the rope consists of a plurality of parallel textile core filaments covered by an envelope and comprising a first uncovered portion of said rope from which the envelope has been removed adjacent the free end thereof, a second uncovered portion of said rope, from which the envelope has been removed spaced from said first portion, at least two bundles of filaments in said second uncovered portion, and at least two bundles of filaments in said first uncovered portion, braided with said at least two bundles of said second portion.

The present invention relates to a spliced loop formed at the end of a textile rope, and also to a method for the manufacture thereof.

Recently, a rope has been proposed which consists of an assembly of parallel textile filaments, generally of synthetic origin and constituting a core, covered by an envelope, which is for example braided or extruded around the said core. An example of such a rope is described in French Patent specification No. 1,327,110. As compared with conventional stranded or braided textile ropes these ropes are lighter due essentially to the absence of shortening (stranding) and, consequently, by greater strength for equal diameter or weight. Moreover, when in use they stretch only to a small degree and, relatively to stranded ropes, they exhibit above all permanent anti-irritatory properties.

Relative to steel cables, apart from the majority of the preceding functional properties, these ropes exhibit a high degree of flexibility and excellent handling qualities.

In a conventional rope or cord, which is stranded or braided in order to produce a terminal splice (also known as a spliced loop), the free end of the rope, the "dead" strand, is unstranded or unbraided as the case may be, and is interlaced with the "live" strand at a distance equal to the developed length of the loop which it is desired to form. This interlacing operation, which is a delicate operation and one which requires a considerable amount of time to effect, is carried out with the aid of a manual apparatus known as a "splicer." Due to the interlacing of the filaments of the "dead" strand with those of the "live" strand, the cabling and stranding torsions maintain the assembly in equilibrium. The spliced loop formed is then self-locking.

The application of this principle to a rope formed by an assembly of parallel filaments is obviously impossible, due to the absence of elementary strands.

According to one aspect of the present invention there is provided a spliced loop in a textile rope in which the rope consists of a plurality of parallel textile core filaments covered by an envelope and comprising a first uncovered portion of said rope from which the envelope has been removed adjacent the free end thereof, a second uncovered portion of said rope, from which the envelope

has been removed spaced from said first portion, at least two bundles of filaments in said second uncovered portion, and at least two bundles of filaments in said first uncovered portion, braided with said at least two bundles of said second portion.

The invention also provides a method of forming a spliced loop in a textile rope consisting of a plurality of parallel textile core filaments covered by an envelope, such method comprising stripping the envelope from the core adjacent a free end of the rope to provide a first uncovered portion of said core filaments, stripping the envelope from the core at a position spaced from said first uncovered portion to provide a second uncovered portion of said core filaments, collecting the filaments of said first uncovered portion into a first set of at least two bundles of filaments, collecting the filaments of said second uncovered portion into a second set of at least two bundles of filaments, and braiding the bundles of said first set with the bundles of said second set to form said loop.

In practice n "dead" bundles and $n-1$ "live" bundles are formed. This number n is obviously a function of the diameter of the rope and the selection thereof is within the scope of the person skilled in the art. For ropes the diameter of which is of the order of one centimeter, n is generally equal to 3.

In the present description, the expression "stripped" designates the operation which consists of removing from the rope the envelope surrounding the core formed by the assembly of parallel filaments.

In order that the invention may more readily be understood the following description is given, merely by way of example, reference being made to the accompanying drawings, wherein:

FIGURE 1 is a schematic side elevation of a rope having parallel core yarns and a braided covering, illustrating the first stage of forming a loop according to the invention;

FIGURES 2 and 3 are views similar to FIGURE 1 illustrating the second and third stages;

FIGURE 4 is a further similar view illustrating the final stages of the formation of the loop.

The drawings show substantially the carrying out of the method of the invention. In one particular example, the rope used had as its core $48 \times 10,000$ -denier core elements and $36 \times 30,000$ -denier core elements each formed from continuous polyhexamethylene adipamide filaments assembled without twist and joined together by a latex. This core was enclosed in a braid produced on a machine having 24 spindles fed with a 10,000-denier rope formed from continuous filaments of polyhexamethylene adipamide. The completed rope weighs approximately 315 grams/metre and has a diameter of 20.5 mm.

In forming the loop according to the invention as shown in FIGURE 1, the braid 1 forming the envelope was removed, firstly at the free end of the rope over a length of 60 cm. to form the "dead" strand and secondly over a length 3 of 40 cm., located entirely within the "live" strand of the rope, at a distance from the "dead" strand 2 which was approximately equal to the developed length of the spliced loop which it was desired to produce i.e., in this case 90 cm.

As shown in FIGURE 2, the "dead" strand 2 was divided into three substantially equal bundles 4 and the "live" strand 3 into two also substantially equal bundles 5. After having folded bundles 4 to a position adjacent bundles 5 as shown in FIGURE 3, the three bundles 4 of the "dead" strand were braided, in a conventional manner, on the two bundles 5 of the "live" strand (FIGURE 4), the bundles 4 being passed over the bundles 5 ten times.

In order to improve the appearance of the spliced rope,

3

the splice may be surrounded by a lacing 6 and/or a vulcanised rubber strip.

In FIGURE 4 the braiding of the bundles 4 and 5 and the lacing are shown symbolically and intentionally deformed, so as to facilitate understanding of the invention.

With the aid of a dynamometer, this rope, retained by the spliced loop, was subjected to a tensile force until rupture occurred under a load of 11.5 metric tons. The fracture took place in the "heart" of the test piece, i.e., in the portion located outside the spliced loop.

The spliced loops produced in accordance with the invention are antigravitatory by nature; furthermore, the bundles of the "live" strand remain substantially parallel and the braiding of the bundles of the "dead" strand is balanced. Additionally they are flexible and, in use, notably due to the absence of stranding, these spliced loops exhibit hardly any tendency to stretch. Similarly, under the influence of a tensile force, these loops also have the property of being self-locking.

We claim:

1. A spliced loop in a textile rope comprising in combination:

- (a) a textile rope including a plurality of parallel textile core filaments and an envelope;
- (b) a free end to said textile rope;
- (c) a first uncovered portion of said rope having the envelope removed adjacent said free end;
- (d) a second uncovered portion of said rope spaced from said first uncovered portion and having the envelope removed therefrom;
- (e) at least two bundles of filaments to said second uncovered portion; and
- (f) at least two bundles of filaments to said first uncovered portion, braided with said at least two bundles of said second portion.

2. The spliced loop defined in claim 1, wherein said first uncovered portion includes three bundles of filaments, and said second uncovered portion includes two bundles of filaments.

3. The spliced loop defined in claim 1, wherein said braided bundles are covered with a lacing.

4. The spliced loop defined in claim 1, wherein said

4

braided bundles are covered with a vulcanised rubber strip.

5. A method of forming a loop in a textile rope, said method comprising the steps of:

- (i) providing a textile rope including a plurality of parallel textile core filaments and an envelope and having a free end;
- (ii) stripping the envelope from the core filaments adjacent the free end to provide a first uncovered portion of said core filaments;
- (iii) stripping the envelope at a location spaced from said first uncovered portion to provide a second uncovered portion of said core filaments;
- (iv) collecting the filaments of said first uncovered portion into a first set of at least two bundles of filaments;
- (v) collecting the filaments of said second uncovered portion into a second set of at least two bundles of filaments; and
- (vi) braiding the bundles of said first set with the bundles of said second set to form said loop.

6. The method defined in claim 5, and including collecting the filaments of said first uncovered portion into three bundles, and collecting the filaments of said second uncovered portion into two bundles.

7. The method defined in claim 5 and including the step of covering the braided bundles with lacing.

8. The method defined in claim 5 and including the step of covering the braided bundles with vulcanised rubber strip.

References Cited

UNITED STATES PATENTS

1,524,671	2/1925	Nyman et al.	87-8
2,575,974	11/1951	Peterson	87-8
3,013,463	12/1961	Gathman et al.	87-8
3,018,319	1/1962	Quayle.	

FOREIGN PATENTS

226,862	1/1960	Australia.
---------	--------	------------

JOHN PETRAKES, *Primary Examiner*.

BIBLIOGRAPHY

ASHLEY, C.W. (1944) The Ashley book of knots. Doubleday Doran.

FERER, K.M. (1973) Factors affecting epoxies used as wire rope terminators in the sea. NRL Memorandum Report 2646.

HOOD, H.A. (1975) Private communication.

HUTSON, R. (1975) Private communication.

RIEWALD, P.G. and T.K. Venkatachalam (1975) Kevlar aramid fiber for rope and cable applications. Marine Technology Society, Cable and Connector Committee.

SWENSON, R.C. (1975) Private communication.