

253112

AFAPL-TR-76-41

ADA 029268

HIGH VOLTAGE DESIGN GUIDE FOR AIRBORNE EQUIPMENT

BOEING AEROSPACE COMPANY
P.O. BOX 3999
SEATTLE, WASHINGTON 98124

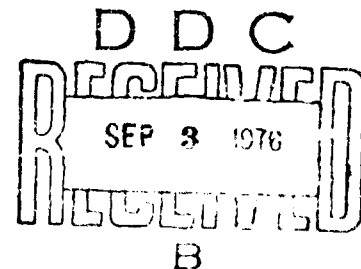

JUNE 1976

TECHNICAL REPORT
FINAL REPORT FOR PERIOD SEPTEMBER 1975 — JUNE 1976

Approved for public release; distribution unlimited

REPRODUCED BY
NATIONAL TECHNICAL
INFORMATION SERVICE
U.S. DEPARTMENT OF COMMERCE
SPRINGFIELD, VA 22161

AIR FORCE AERO PROPULSION LABORATORY
AIR FORCE SYSTEMS COMMAND
WRIGHT PATTERSON AIR FORCE BASE, OHIO 45433

NOTICE

When Government drawings, specifications, or other data are used for any purpose other than in connection with a definitely related Government procurement operation, the United States Government thereby incurs no responsibility nor any obligation whatsoever; and the fact that the government may have formulated, furnished, or in any way supplied the said drawings, specifications, or other data, is not to be regarded by implication or otherwise as in any manner licensing the holder or any other person or corporation, or conveying any rights or permission to manufacture, use, or sell any patented invention that may in any way be related thereto

This final report was submitted by the Boeing Aerospace Company, under Contract F33615-76-C-2008. The effort was sponsored by the Air Force Aero Propulsion Laboratory, Air Force Systems Command, Wright-Patterson AFB, Ohio under Project 3145, Task 32 and Work Unit 38 with Hugh L. Southall/AFAPL/POD-1 as Project Engineer. Mr. William G. Dunbar, Boeing Aerospace Company was technically responsible for the work.

The program at the Boeing Aerospace Company, Seattle, Washington, was supervised by Henry Oman and Sidney W. Silverman, with technical work being done by William G. Dunbar and Joseph W. Seabrook.

This report has been reviewed by the Information Office, (ASD/OIP) and is releasable to the National Technical Information Service (NTIS). At NTIS, it will be available to the general public, including foreign nations.

This technical report has been reviewed and is approved for publication.

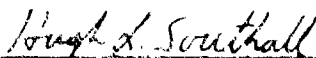

Hugh L. Southall, Capt. USAF
Project Engineer

FOR THE COMMANDER



Phillip E. Stover
Chief, High Power Branch

Copies of this report should not be returned unless return is required by security considerations, contractual obligations, or notice on a specific document.

REPORT DOCUMENTATION PAGE		READ INSTRUCTIONS BEFORE COMPLETING FORM
1. REPORT NUMBER AFAPL-TR-76-41	2. GOVT ACCESSION NO.	3. RECIPIENT'S CATALOG NUMBER
4. TITLE (and Subtitle) HIGH VOLTAGE DESIGN GUIDE FOR AIRBORNE EQUIPMENT		5. TYPE OF REPORT & PERIOD COVERED Final 26 September 1975-June 1976
		6. PERFORMING ORG. REPORT NUMBER 1
7. AUTHOR(s) W. G. Dunbar J. W. Seabrook		8. CONTRACT OR GRANT NUMBER(s) F33615-76-C-2008
9. PERFORMING ORGANIZATION NAME AND ADDRESS Boeing Aerospace Company P.O. Box 3999 Seattle, Washington, 98124		10. PROGRAM ELEMENT, PROJECT, TASK AREA & WORK UNIT NUMBERS Project 3145 Task 32 Work Unit 38
11. CONTROLLING OFFICE NAME AND ADDRESS Air Force Aero-Propulsion Laboratory AFAPL/POD-1 Wright-Patterson AFB, Ohio 45433		12. REPORT DATE June 1976
		13. NUMBER OF PAGES 119
14. MONITORING AGENCY NAME & ADDRESS (if different from Controlling Office)		15. SECURITY CLASS. (of this report) Unclassified
		15a. DECLASSIFICATION/DOWNGRADING SCHEDULE
16. DISTRIBUTION STATEMENT (of this Report) Approved for Public Release; Distribution Unlimited		
17. DISTRIBUTION STATEMENT (of the abstract entered in Block 20, if different from Report)		
18. SUPPLEMENTARY NOTES		
19. KEY WORDS (Continue on reverse side if necessary and identify by block number) Corona High Voltage Test Creepage Impulse Voltage Tracking Dielectric withstanding voltage Partial Discharges Electrical Insulation Paschen Law Field Theory Utilization Factor		
20. ABSTRACT (Continue on reverse side if necessary and identify by block number) This report supplies the theoretical background and design techniques needed by an engineer who is designing electrical insulation for high-voltage high-power components, equipment, and systems on aircraft. A literature survey and abundant bibliography identify references that provide further data on the subjects of partial discharges, corona, field theory and plotting, voids and processes for applying insulation. Both gaseous and solid insulations are treated. Cryogenic and liquid design notes are included.		

20. ABSTRACT (Continued)

Tests and test equipment for high voltage insulation and equipment are defined. Requirements of test plans and procedures for high-voltage high-power equipment are identified and illustrated by examples.

Suggestions for high-voltage specifications are provided. Very few of the Military and Government specifications deal with system voltages above 10kv, thus most aircraft high-voltage specifications will have to be derived from the power industry specifications and standards produced by ASTM, IEEE, and NEMA.

ACCESSION for	
NTIS	Write Section <input checked="" type="checkbox"/>
BBC	Buff Section <input type="checkbox"/>
UNANNOUNCED	<input type="checkbox"/>
JUSTIFICATION	
BY	
DISTRIBUTION/AVAILABILITY CODES	
Dist.	A..TL and/or SPECIAL
A	

CONTENTS

	<u>Page</u>
FRONT COVER	1
NOTICE PAGE	11
DD FORM 1473	111
TABLE OF CONTENTS	v
ILLUSTRATIONS	x
TABLES	xiv
GLOSSARY	1
1.0 INTRODUCTION	13
1.1 Definition of "Insulation"	13
1.2 Design Guide Content	14
2.0 BACKGROUND	15
2.1 Program Plan and Requirements	15
2.2 Requirements Specifications	16
2.3 Planning A High-Voltage Program	16
2.4 Design-and-Test Plan	19
3.0 FUNDAMENTALS OF INSULATIONS	21
3.1 Gases	21
3.1.1 Electronegative Gases	25
3.1.2 Corona	25
3.1.3 Paschen Law	26
3.1.4 Penning Effect	29
3.1.5 Breakdown of Gases	29
3.1.6 Voltage Transients and Time Lag	38
3.2 Solid Insulation	38
3.2.1 Materials Properties	39
3.2.2 Materials Data Pamphlets	43

CONTENTS (CONTINUED)

	<u>Page</u>
3.3 Basic Theory of Partial Discharges in Cracks and Voids	56
3.3.1 Size, Shape, Location, and Distribution of Voids and Cracks	56
3.3.2 Material Dielectric Constant and Conductivity	62
3.3.3 Gas Pressure and Composition	64
3.3.4 Surface Surrounding Void	65
3.3.5 Temperature Effects	65
3.3.6 Impressed Voltage	67
3.4 Surface Effects	71
3.4.1 Effect of Temperature on Flashover Strength	73
3.4.2 Other Effects	75
3.5 Liquid Dielectrics	78
3.5.1 Selection	78
3.5.2 The Effect of Temperature	78
3.5.3 The Effect of Moisture	79
3.5.4 Dissolved Gas	81
3.5.5 Breakdown Phenomena	81
3.5.6 Mineral Oil	82
3.5.7 Askareis	87
3.5.8 Silicone Oils	87
3.5.9 Miscellaneous Insulation Liquids	89
3.5.10 Filtering and Outgassing	90
3.6 Cryogenic Liquids	90
3.6.1 Cryogenic Liquids	90
3.6.2 Dielectric Properties of Cryogenic Liquids	92
3.6.3 Theory of Conductivity and Breakdown	93
3.6.4 Solid Insulators at Cryogenic Temperatures	99
3.6.5 Vacuum at Cryogenic Temperatures	101

CONTENTS (CONTINUED)

	<u>Page</u>
3.6.6 Application Notes	102
3.7 Voltage Stress For Several Electrode Configurations	102
3.7.1 Electric Fields	102
3.7.2 Configurations	104
3.7.3 Empirical Field Equations	107
3.7.4 Utilization Factor	109
3.7.5 Freehand Field Plotting	109
3.7.6 Mathematical Mapping Techniques	111
4.0 EQUIPMENT	112
4.1 Wiring and Connectors	112
4.1.1 Design Considerations	112
4.1.2 High Voltage Cable	115
4.1.3 High Voltage Connectors	118
4.2 Capacitors	119
4.2.1 Construction and Processing	119
4.2.2 Dielectrics	120
4.2.3 Essential Design Features	120
4.2.4 Failure Modes and Mechanisms	121
4.2.5 Effects of Partial Discharges	122
4.2.6 Failure Rate Prediction	124
4.2.7 Check List of Significant Characteristics	126
4.3 Magnetic Devices	127
4.3.1 Encapsulation	128
4.3.2 Terminal Boards and Supports	130
4.3.3 High Voltage Leads	135
4.3.4 Special Design Features	136

CONTENTS (CONTINUED)

	<u>Page</u>
4.4 Solid State and Vacuum Parts	138
4.4.1 Fields	139
4.4.2 Taps and Plates	139
4.4.3 Control Wiring	140
4.4.4 Insulated High Voltage Wiring	141
5.0 TESTS	143
5.1 Insulation Tests	143
5.2 Materials Testing	143
5.3 Component and Equipment Tests	144
5.3.1 Insulation Resistance	146
5.3.2 High Potential Test	146
5.3.3 Impulse Tests	147
5.3.4 Corona Tests	151
5.4 Performance Testing	158
5.4.1 Testing and Detection	158
5.4.2 Equipment Testing	158
5.4.3 High Voltage Testing	158
5.4.4 Parts Tests	159
5.4.5 Circuit Tests	160
5.4.6 System Tests	160
5.5 Facility and Environment	160
5.5.1 Contamination	162
5.5.2 Life Testing	162
6.0 QUALITY ASSURANCE PROVISIONS, SPECIFICATIONS AND STANDARDS	164
6.1 Specifications and Standards	164
6.2 Military Specifications and Standards	164
6.3 Safety	165

TABLE OF CONTENTS (CONTINUED)

	<u>Page</u>
7.0 POSSIBLE PROBLEM AREAS AND SUGGESTED SOLUTIONS	170
7.1 Debris	170
7.2 Mechanical Stress	170
7.3 Flexible Wiring	170
7.4 Manufacturing Cleanliness	170
7.5 Mold Release Agents	171
7.6 Similarity	171
7.7 Testing	171
7.8 Environment and Life	171
7.9 Tabs	172
7.10 Spacers	172
7.11 Coatings	172
7.12 Determining Corona Limitation Voltage	172
8.0 CONCLUSIONS	174
APPENDIX A	175
A1 Freehand Field Plotting	175
A2 Resistance Paper	177
A3 Other Field Plotting Techniques	170
APPENDIX B	181
APPENDIX C	192
APPENDIX D	199

ILLUSTRATIONS

<u>Figure</u>	<u>Page</u>
1. HIGH VOLTAGE, HIGH POWER SYSTEM DEVELOPMENT PLAN	17
2. REQUIREMENTS PLAN	18
3. DESIGN AND TEST PLAN	20
4. VOLTAGE CURRENT CHARACTERISTIC FOR A GAS IN A UNIFORM ELECTRIC FIELD	23
5. DERIVATION OF TOWNSEND'S BREAKDOWN CRITERION	24
6. VOLTAGE BREAKDOWN OF PURE GASES AS A FUNCTION OF PRESSURE TIMES SPACING	28
7. ELECTRODE GEOMETRIES	31
8. BREAKDOWN VOLTAGE CURVES OF GASES BETWEEN A HEMISPHERICALLY-ENDED ROD, OF 0.1 IN. DIAMETER, AND A SPHERE OF 1.0 IN. DIAMETER. THE GAS PRESSURE IS 1 ATM	34
9. BREAKDOWN VOLTAGE AT 60 Hz	35
10. PERFORMANCE OF UNLOADED POLYURETHANE COATED ELECTRODES UNDER DC VOLTAGES	36
11. PERFORMANCE OF ANODIZED ALUMINUM ELECTRODES UNDER DC VOLTAGES	36
12. AC BREAKDOWN VOLTAGE-GAP CHARACTERISTICS IN SF ₆ WITH COPPER PARTICLES OF VARIOUS LENGTH	37
13. RELATION BETWEEN FORMATIVE TIME AND IMPULSE RATIO FOR VARIOUS GAP LENGTHS AND GAS PRESSURE IN A NEGATIVE POINT-SPHERE GAP IN AIR	39
14. DIELECTRIC POLARIZATIONS	42
15. TEMPERATURE AFFECTS AC DIELECTRIC STRENGTH OF TYPE H KAPTON FILM	45
16. HIGH HUMIDITY DEGRADES THE DIELECTRIC STRENGTH OF TYPE H KAPTON FILM	46
17. INSULATION THICKNESS AFFECTS DIELECTRIC STRENGTH OF TYPE H KAPTON FILM	46
18. FILM AREA VS DIELECTRIC STRENGTH OF TYPE H KAPTON	48
19. LIFE AS A FUNCTION OF VOLTAGE FOR TYPE H KAPTON FILM	50
20. HEAT REDUCES THE TIME FOR KAPTON TYPE H FILM TO FALL TO HALF OF ORIGINAL DIELECTRIC STRENGTH	51

ILLUSTRATIONS

<u>Figure</u>	<u>Page</u>
21. DIELECTRIC CONSTANT VS FREQUENCY FOR 1 MIL THICK TYPE H KAPTON FILM	53
22. DISSIPATION FACTOR VS FREQUENCY FOR 1 MIL THICK TYPE H KAPTON FILM	54
23. VOLUME RESISTIVITY OF TYPE H KAPTON FILM AT 1 KHZ DECREASES AS TEMPERATURE IS RAISED	55
24. TEST CIRCUIT FOR MEASUREMENT OF PARTIAL DISCHARGES	57
25. STRESS INCREASE IN VOIDS	59
26. PRESSURE TIMES SPACING AS A FUNCTION OF TEMPERATURES	68
27. DEPENDENCE OF TAN δ ON THE AC VOLTAGE WITH SIMULTANEOUS DC VOLTAGE. IMPREGNATED PAPER CABLE INSULATION. 96.0°C, 50 Hz	70
28. LOWER BREAKDOWN VOLTAGE RESULTS FROM HIGH FREQUENCY	71
29. FLASHOVER FIXTURE	72
30. EFFECT OF SPACING ON FLASHOVER STRESS	73
31. EFFECT OF TEMPERATURE ON 60 HZ FLASHOVER STRESS	74
32. EFFECT OF FREQUENCY ON FLASHOVER STRENGTH FOR CONFIGURATION SHOWN IN FIGURE 29	75
33. VARIATION OF VOLTAGE BREAKDOWN WITH CHANGING INSULATED DIELECTRIC CONSTANT	76
34. EFFECT OF TEMPERATURE ON CONDUCTION CURRENT IN DEGASSED TRANSFORMER OIL	80
35. NORMAL USABLE TEMPERATURE RANGE OF LIQUID DIELECTRIC CLASSES	80
36. OXIDATION OF TRANSFORMER OILS IN ATMOSPHERE AT 100°C. INTERFACIAL TENSION OF 15 DYN/CM VERSUS POLYNUCLEAR OXYGEN CONTENT OF THE OIL	84
37. DISSIPATION FACTOR AT SEVERAL FREQUENCIES FOR LIQUID HYDROGEN, NITROGEN, AND HELIUM	94
38. DISSIPATION FACTOR VERSUS VOLTAGE GRADIENT FOR LIQUID NITROGEN AT 77°K (NOT BOILING) AND THREE FREQUENCIES	94
39. DISSIPATION FACTOR AT 1 KHZ AND UNDER 100 VOLTS	100
40. FIELD LINES BETWEEN A HIGH VOLTAGE CONDUCTOR AND GROUND	103
41. CORONA INITIATION VOLTAGE BETWEEN POINTS, RODS, AND PLATES	105
42. UTILIZATION FACTOR FOR VARIOUS ELECTRIC FIELD DISTRIBUTIONS	110

ILLUSTRATIONS

<u>Figure</u>	<u>Page</u>
43. OUTER JACKET RUPTURE	113
44. CENTER CONDUCTOR DELAMINATION	113
45. HIGH VOLTAGE WIRE	115
46. FIELD GRADIENT FOR SINGLE AND MULTIPLE LAYER DIELECTRIC	116
47. HIGH VOLTAGE CONNECTOR	118
48. DIELECTRIC LIFE OF POLYETHYLENE WITH AND WITHOUT CORONA	123
49. FAILURE RATE OF CAPACITORS	125
50. TERMINAL BOARDS	134
51. HIGH VOLTAGE LEAD AND BUSHING	135
52. HIGH VOLTAGE TERMINALS	136
53. HIGH VOLTAGE TIES	137
54. ROUND CORNERS ON ENCAPSULATED COILS	138
55. CURVED EDGE ON HIGH VOLTAGE PLATE	140
56. WAVEFORM FOR BASIC INSULATION LEVEL (BIL) DEFINITION	149
57. DIELECTRIC-WITHSTANDING-VOLTAGE MARGIN AFFECTS INSULATION LIFE	149
58. RELATION BETWEEN ELECTRICAL STRESS AND NUMBER OF IMPULSES REQUIRED TO PRODUCE BREAKDOWN WITH 1/50 MICROSECOND IMPULSES	151
59. BRIDGE DETECTOR CIRCUIT	154
60. CIRCUIT FOR PARTIAL-DISCHARGE PULSE-HEIGHT DISTRIBUTION ANALYSIS WITH VARIABLE-RISE-TIME PULSE CALIBRATOR	155
61. FREQUENCY SPECTRUM AT CORONA DISCHARGE	157
62. NOISE AND CORONA RECORDINGS	161
63. CIV OF COMMON GASES	173
A1. FREEHAND FIELD MAPPING	176
A2. FREEHAND FIELD MAPPING	176
A3. RESISTANCE PAPER PLOT CIRCUIT	178
A4. PLOT OF EQUIPOTENTIAL LINES USING RESISTANCE PAPER	178
A5. BLOCK DIAGRAM OF ELECTROLYTIC TREATMENT	180

ILLUSTRATIONS

<u>Figure</u>		<u>Page</u>
B1	FINITE DIFFERENCE GRID. POTENTIAL GIVEN AS PERCENTAGE OF NOMINAL TEST VOLTAGE	182
B2	IRREGULAR STAR IN TWO DIMENSIONAL CARTESIAN CO-ORDINATES	184
B3	IRREGULAR STAR IN THREE-DIMENSIONAL CARTESIAN CO-ORDINATES	184
B4	IRREGULAR STAR IN CIRCULAR CYLINDRICAL CO-ORDINATES	185
B5	COMPUTER PROGRAM FLOW CHART	188
C1	IDEALIZED Q-V LOOP TRACE	193
D1	CIRCUIT DIAGRAM OF A TYPICAL CHARGE-VOLTAGE-TRACE-BRIDGE	200

TABLES

<u>Table</u>	<u>Page</u>
1. BREAKDOWN VOLTAGE BETWEEN BARE ELECTRODES SPACED ONE CENTIMETER	30
2. PUBLISHED EQUATIONS FOR SPARKOVER GRADIENTS E_s , IN SF ₆	32
3. SPARKOVER GRADIENTS IN AIR	33
4. PROPERTIES OF INTEREST FOR INSULATING MATERIALS	40
5. TYPICAL ELECTRICAL PROPERTIES OF POLYIMIDE FILM AT 23°C AND 50% RELATIVE HUMIDITY	44
6. COMPARISON OF STEADY-STATE AND IMPULSE FLASHOVER STRESS, V/mm (PEAK) FOR GLASS EPOXY-BAND LAMINATES	74
7. THE AVERAGE CHARACTERISTICS OF MINERAL INSULATING OIL	83
8. MATERIALS COMPATIBILITY WITH MINERAL OILS	86
9. TYPICAL CHARACTERISTICS AND USES OF ASKAREL INSULATING LIQUIDS	88
10. MATERIALS COMPATIBILITY WITH ASKARELS	89
11. BOILING POINTS OF GASES	91
12. PHYSICAL DATA FOR CRYOGENIC FLUIDS	93
13. DIELECTRIC CONSTANT	95
14. COMPARISON OF VOLTAGE BREAKDOWN OF CRYOGENIC LIQUIDS	96
15. INFLUENCE OF ELECTRODES ON ELECTRIC STRENGTH OF CRYOGENIC LIQUIDS	97
16. BREAKDOWN VOLTAGE, kV/mm VS PRESSURE (62.5 mm SPHERICAL ELECTRODES SPACED 1 mm)	98
17. 50 Hz VOLTAGE BREAKDOWN STRESS, MV/cm rms AT LIQUID HELIUM TEMPERATURE, 4.2°K	101
18. MAXIMUM FIELD STRENGTH E WITH A POTENTIAL DIFFERENCE V BETWEEN THE ELECTRODES, FOR DIFFERENT ELECTRODE CONFIGURATIONS	108
19. POLYETHYLENE-DIELECTRIC STRENGTH, V/mil, FOR 30-MIL SHEETS AS FUNCTIONS OF TEMPERATURE AND FREQUENCY	114
20. TEFLON-DIELECTRIC STRENGTH, V/mil, FOR 30-MIL SHEET AS A FUNCTION OF TEMPERATURE AND FREQUENCY	114

TABLES

<u>Table</u>	<u>Page</u>
21. PERFORMANCE OF INSULATING MATERIALS AT LOW TEMPERATURES AND 10^{-4} N/cm ² PRESSURE	129
22. SUCCESSFUL AEROSPACE DIELECTRIC MATERIALS	131
23. PROPERTIES OF 3M SCHOTCHCAST 281 EPOXY	132
24. PROPERTIES OF LAMINATES AND COMPOSITIONS	133
25. TESTS OF ELECTRICAL PROPERTIES OF INSULATION	145
26. CAPACITORS	166
27. CONNECTORS	167
28. WIRE AND CABLES	168
29. EQUIPMENT	169

GLOSSARY

- Adsorption.** The adhesion of gas or liquid molecules to the surfaces of solids or liquids with which they are in contact.
- Aging.** The change in properties of a material with time under specific conditions.
- Alternating Current.** Current in which the charge-flow periodically reverses and is represented by: $I = I_0 \cos(2\pi ft + \phi)$ where I is the current, I_0 is the amplitude, f the frequency, ϕ the phase angle.
- Ambient Temperature.** The temperature of the surrounding cooling medium, such as gas or liquid, which comes into contact with the heated parts of the apparatus.
- Anode.** The electrode through which a direct current enters the liquid, gas, or other discrete part of an electrical circuit; the positively charged pole of an electrochemical cell.
- Anti-Oxidant.** Substance which prevents or slows down oxidation of material exposed to air.
- Arcover Voltage.** The minimum voltage required to create an arc between electrodes separated by a gas or liquid insulation under specified conditions.
- Arc Resistance.** The time required for an arc to establish a conductive path in a material.
- Askarel.** Synthetic liquid dielectric which is non-flammable.
- Bond Strength.** The amount of adhesion between bonded surfaces.
- Breakdown (Puncture).** A disruptive discharge through insulation.
- Breakdown Voltage.** The voltage at which the insulation between two conductors will break down.
- Capacitance (Capacity).** That property of a system of conductors and dielectrics which permits the storage of electricity when potential difference exists between the conductors. Its value is expressed as the ratio of a quantity of electricity to a potential difference. A capacitance value is always positive. The charge which must be communicated to a body to raise its potential one unit, represented by $C = Q/V$, where C is the capacitance, Q the quantity of charge, and V the potential. In a parallel plate condenser

$$C = \frac{KA}{d}$$

where A is the area of the plates, d the distance between them, and K the dielectric constant of the medium.

- Capacitor (Condenser). A device, the primary purpose of which is to introduce capacitance into an electric circuit.
- Cathode. The electrode through which an electric current leaves a liquid, gas, or other discrete part of an electric current; the negatively charged pole of an electrochemical cell.
- Cavity. Depression in a mold.
- Cell. A single unit capable of serving as a d-c voltage source by means of transfer of ions in the course of a chemical reaction.
- Charge. In electrostatics, the amount of electricity present upon any substance which has accumulated electric energy.
- Conductance. The reciprocal of resistance. It is the ratio of current passing through a material to the potential difference at its ends.
- Conductivity. Reciprocal of volume resistivity. Conductance of a unit cube of any material.
- Conductor. An electrical path which offers comparatively little resistance. A wire or combination of wires not insulated from one another, suitable for carrying a single electric current.
- Contaminant. An impurity or foreign substance present in a material which affects one or more properties of the material.
- Corona. A luminous discharge due to ionization of the gas surrounding a conductor around which exists a voltage gradient exceeding a certain critical value. A type of discharge--sometimes visible--in the dielectric of an insulation system caused by an electric field and characterized by the rapid development of an ionized channel which does not completely bridge the electrode. May be continuous or intermittent. Not a materials property, but related to the system, including electrodes.
- Corona resistance. The time that insulation will withstand a specified level field-intensified ionization that does not result in the immediate complete breakdown of the insulation.
- Corrosion. Chemical action which causes destruction of the surface of a metal by oxidation or chemical combination.
- Coulomb. Unit quantity of electricity; i.e., the quantity transferred by 1 ampere in one second.
- Creep. The dimensional change with time of a material under load.
- Creepage. Electrical leakage on a solid dielectric surface.
- Creepage surface on path. An insulating surface which provides physical separation as a form of insulation between two electrical conductors of different potential.

Critical Voltage (of gas). The voltage at which a gas ionizes and corona occurs, preliminary to dielectric breakdown of the gas.

Delamination. The separation of layers in a laminate through failure of the adhesive.

Dielectric. (1) Any insulating medium which intervenes between two conductors and permits electrostatic attraction and repulsion to take place across it. (2) A material having the property that energy required to establish an electric field is recoverable in whole or in part, as electric energy.

Dielectric Adsorption. That property of an imperfect dielectric whereby there is an accumulation of electric charges within the body of the material when it is placed in an electric field.

Dielectric Constant (permittivity or specific inductive capacity). That property of a dielectric which determines the electrostatic energy stored per unit volume for unit potential gradient. The dielectric constant of a medium is defined by ϵ in the equation

$$F = \frac{QQ'}{4\pi\epsilon r^2}$$

where F is the force of attraction between two charges Q and Q' separated by a distance r in a uniform medium.

Dielectric Loss. The time rate at which electric energy is transformed into heat in a dielectric when it is subjected to a changing electric field.

Dielectric Loss Angle (dielectric phase difference). The difference between ninety degrees (90°) and the dielectric phase angle.

Dielectric Loss factor (dielectric loss index). The product of its dielectric constant and the tangent of its dielectric loss angle.

Dielectric Phase Angle. The angular difference in phase between the sinusoidal alternating potential difference applied to a dielectric and the component of the resulting alternating current having the same period as the potential difference.

Dielectric Power Factor. The cosine of the dielectric phase angle (or sine of the dielectric loss angle).

Dielectric Strength. The voltage which an insulating material can withstand before breakdown occurs, usually expressed as a voltage gradient (such as volts per mil).

Dielectric Test. Tests which consist of the application of a voltage higher than the rated voltage for a specified time for the purpose of determining the adequacy against breakdown of insulating materials and spacings under normal conditions.

Dispersion. Finely divided particles in suspension in another substance.

Displacement Current. A current which exists in addition to ordinary conduction current in a-c circuits. It is proportional to the rate of change of the electric field.

Disruptive Discharge. The sudden and large increase in current through an insulation medium due to the complete failure of the medium under the electrostatic stress.

Dissipation Factor (loss tangent, $\tan \delta$, approx. power factor). The tangent of the loss angle of the insulating material.

Electric Field Intensity. The force exerted on a unit charge. The field intensity E is measured by

$$E = \frac{q}{4\pi\epsilon r^2}$$

where r is the distance from the charge q in a medium having a dielectric constant ϵ .

Electric Strength (dielectric strength)(disruptive gradient). The maximum potential gradient that the material can withstand without rupture. The value obtained for the electric strength will depend on the thickness of the material and on the method and conditions of test.

Electrode. A conductor, not necessarily metal, through which a current enters or leaves an electrolytic cell, arc, furnace, vacuum tube, gaseous discharge tube, or any conductor of the non-metallic class.

Electromagnetic Field. A rapidly moving electric field and its associated moving magnetic field, located at right angles both to the electric lines of force and to their direction of motion.

Electron. That portion of an atom which circles around the center, or nucleus. An electron possesses a negative electric charge, and is the smallest charge of negative electricity known.

Encapsulating. Enclosing an article in a closed envelope of plastic.

Energy of a Charge. $W = \frac{1}{2}QV$, given in ergs when the charge Q and the potential V are in electrostatic units.

Energy of the Electric Field. Represented by $W = KE^2$ where E is the electric field intensity in electrostatic units, K the specific inductive capacity, and the energy of the field E in ergs per cm^3 .

Epoxy Resins. Straight-chain thermoplastics and thermosetting resins based on ethylene oxide, its derivatives or homologs.

- Farad.** Unit of capacitance. The capacitance of a capacitor which, when charged with one coulomb, gives a difference of potential of one volt.
- Fiber.** A thread or threadlike structure such as comprises cellulose, wool, silk, or glass yarn.
- Fibre.** A specific form of chemically gelled fibrous materials fabricated into sheets, rods, tubes, and the like.
- Filler.** A substance, often inert, added to a plastic to improve properties and/or decrease cost.
- Flame Resistance.** Ability of the material to extinguish flame once the source of heat is removed.
- Flammability.** Measure of the material's ability to support combustion.
- Flashover.** A disruptive discharge around or over the surface of a solid or liquid insulator.
- Frequency.** The number of complete cycles or vibrations per unit of time.
- Graded Insulation.** Combination insulations with the portions thereof arranged in such a manner as to improve the distribution of the electric field to which the insulation combination is subjected.
- Gradient.** Rate of increase or decrease of a variable magnitude.
- Grounded Parts.** Parts which are so connected that, when the installation is complete, they are substantially of the same potential as the earth.
- Ground Insulation.** The major insulation used between a winding and the magnetic core or other structural parts, usually at ground potential.
- Hall Effect.** The development of a potential difference between the two edges of a strip of metal in which an electric current is flowing longitudinally, when the plane of the strip is perpendicular to a magnetic field.
- Hardener.** A substance or mixture of substances added to plastic composition, or an adhesive to promote or control the curing reaction by taking part in it.
- Heat Sink.** Any device that absorbs and draws off heat from a hot object, radiating it into the surrounding atmosphere.
- Hertz.** (Hz) A term replacing cycles-per-second as an indication of frequency.
- Hygroscopic.** Tending to absorb moisture.
- Hysteresis.** An effect in which the magnitude of a resulting quantity is different during increases in the magnitude of the cause than during decreases due to internal friction in a substance and accompanied by the production of heat within the substance. Electric hysteresis occurs when a dielectric material is subjected to a varying electric field as in a capacitor in an alternating-current circuit.

Impedance. The total opposition that a circuit offers to the flow of alternating current or any other varying current at a particular frequency. It is a combination of resistance R and reactance X, measured in ohms and designated by Z. $Z = (R^2 + X^2)^{1/2}$.

Impregnate. To fill the voids and interstices of a material with a compound. (This does not imply complete fill or complete coating of the surfaces by a hole-free film).

Impulse. A surge of unidirectional polarity.

Impulse Ratio. The ratio of the flashover, sparkover, or breakdown voltage of an impulse to the crest value of the power-frequency flashover, sparkover, or breakdown voltage.

Insulation. Material having a high resistance to the flow of electric current, to prevent leakage of current from a conductor.

Insulation Resistance. The ratio of the applied voltage to the total current between two electrodes in contact with a specific insulator.

Insulation System. All of the insulation materials used to insulate a particular electrical or electronic product.

Insulator. A material of such low electrical conductivity that the flow of current through it can usually be neglected.

Interstice. A minute space between one thing and another, especially between things closely set or between the parts of a body.

Ion. An electrified portion of matter of sub-atomic, atomic, or molecular dimensions such as is formed when a molecule of gas loses an electron (when the gas is stressed electrically beyond the critical voltage) or when a neutral atom or group of atoms in a fluid loses or gains one or more electrons.

Ion Exchange Resins. Small granular or bead-like particles containing acidic or basic groups, which will trade ions with salts in solutions.

Ionization. Generally, the dissociation of an atom or molecule into positive or negative ions or electrons. Restrictively, the state of an insulator whereby it facilitates the passage of current due to the presence of charged particles usually induced artificially.

Laminated Plastics. Layers of a synthetic resin-impregnated or coated base material bonded together by means of heat and pressure to form a single piece.

Lamination. The process of preparing a laminate. Also any layer in a laminate.

Line of Force. Used in the description of an electric or magnetic field to represent the force starting from a positive charge and ending on a negative charge.

Mat. A randomly distributed felt of glass fibers used in reinforced plastics.

Moisture Resistance. The ability of a material to resist absorbing moisture from the air or when immersed in water.

Nylon. The generic name for synthetic fiber-forming polyamides.

Open Cell. Foamed or cellular material with cells which are generally interconnected. Closed cells refers to cells which are not interconnected.

Organic. Designating or composed of matter originating in plant or animal life or composed of chemicals of hydrocarbon origin, either natural or synthetic.

Oscillatory Surge. A surge which includes both positive and negative polarity values.

Overpotential. A voltage above the normal operating voltage of a device or circuit.

Overvoltage. See Overpotential.

Partial Discharge: A partial discharge is an electric discharge that only partially bridges the insulation between conductors when the voltage stress exceeds a critical value. These partial discharges may, or may not, occur adjacent to a conductor.

Partial discharge is often referred to as "corona" but the term "corona" is preferably reserved for localized discharges in cases around a conductor, bare or insulated, remote from any other solid insulation.

Partial Discharge Pulse: A partial discharge pulse is a voltage or current pulse which occurs at some designated location in the test circuit as a result of a partial discharge.

Partial Discharge Pulse Charge: The quantity of charge supplied to the test specimen's terminals from the applied voltage source after a partial discharge pulse has occurred. The pulse charge is often referred to as the apparent charge or terminal charge. The pulse charge is related but not necessarily equal to the quantity of charge flowing in the localized discharge.

Partial Discharge Pulse Energy: The partial discharge pulse energy is the energy dissipated during one individual partial discharge.

Partial Discharge Pulse Repetition Rate: The partial discharge pulse repetition rate is the number of partial discharge pulses of specified magnitude per unit time.

Partial Discharge Pulse Voltage: The peak value of the voltage pulse which, if inserted in the test circuit at a terminal of the test specimen, would produce a response in the circuit equivalent to that resulting from a partial discharge pulse within the specimen. The pulse voltage is also referred to as the terminal corona pulse voltage.

Permittivity. Preferred term for dielectric constant.

pH. The measure of the acidity or alkalinity of a substance, neutrality being at pH 7. Acid solutions are under 7, alkaline solutions over 7.

Phenolic Resin. A synthetic resin produced by the condensation of phenol with formaldehyde.

Plastic. High polymeric substances, including both natural and synthetic products, but excluding the rubbers, that are capable of flowing under heat and pressure at one time or another.

Plastic Deformation. Change in dimensions of an object under load that is not recovered when the load is removed.

Plasticizer. Chemical agent added to plastics to make them softer and more flexible.

Polarity. 1) An electrical condition determining the direction in which current tends to flow. 2) The quality of having two opposite charges.

Polyamide. A polymer in which the structural units are linked by amide or thioamide groupings.

Polycarbonate Resins. Polymers derived from the direct reaction between aromatic and aliphatic dihydroxy compounds with phosgene or by the ester exchange reaction with appropriate phosgene derived precursors.

Polyester. A resin formed by the reaction between a dibasic acid and a dihydroxy alcohol.

Polyethylene. A thermoplastic material composed of polymers of ethylene.

Polyisobutylene. The polymerization product of isobutylene, also called butyl rubber

Polymer. A compound formed by polymerization which results in the chemical union of monomers or the continued reaction between lower molecular weight polymers.

Polymerize. To unite chemically two or more monomers or polymers of the same kind to form a molecule with higher molecular weight.

Polyethyl Methacrylate. A transparent thermoplastic composed of polymers of methyl methacrylate.

Polypropylene. A plastic made by the polymerization of high-purity propylene gas in the presence of an organometallic catalyst at relative low pressures and temperatures.

Polystyrene. A thermoplastic produced by the polymerization of styrene (vinyl benzene).

Polyvinyl Acetate. A thermoplastic material composed of polymers of vinyl acetate

- Polyvinyl Butyral.** A thermoplastic material derived from butyraldehyde.
- Polyvinyl Chloride (PVC).** A thermoplastic material composed of polymers of vinyl chloride.
- Polyvinyl Chloride Acetate.** A thermoplastic material composed of copolymers of vinyl chloride and vinyl acetate.
- Polyvinylidene Chloride.** A thermoplastic material composed of polymers of vinylidene chloride (1,1-dichloroethylene).
- Potential.** Voltage. The work per unit charge required to bring any charge to the point at which the potential exists.
- Potting.** Similar to encapsulating, except that steps are taken to insure complete penetration of all voids in the object before the resin polymerizes.
- Power.** The time rate at which work is done; equal to W/t where W is amount of work done in time t . Power will be obtained in watts if W is expressed in joules and t in seconds.
- Power Factor.** 1) In an alternating current circuit, it is the number of watts indicated by a watt meter, divided by the apparent watts, the latter being the watts as measured by a voltmeter and ammeter. 2) It is the multiplier used with the apparent watts to determine how much of the supplied power is available for use. 3) That quantity by which the apparent watts must be multiplied in order to give the true power. 4) Mathematically, the cosine of the angle of phase difference between current and voltage applied.
- Pressure.** Force measured per unit area. Absolute pressure is measured with respect to zero pressure. Gauge pressure is measured with respect to atmospheric pressure.
- Proton.** A positively charged particle believed to be a nuclear constituent of all atoms.
- Pulp.** Cellulose obtained from wood or other vegetable matter by cooking with chemicals.
- Relative Humidity.** Ratio of the quantity of water vapor present in the air to the quantity which would saturate it at any given temperature.
- Resin.** An organic substance of natural or synthetic origin characterized by being polymeric in structure and predominantly amorphous. Most resins, though not all, are of high molecular weight and consist of long chain or network molecular structure. Usually resins are more soluble in their lower molecular weight forms.
- Resistance.** Property of a conductor that determines the current produced by a given difference of potential. The ohm is the practical unit of resistance.
- Resistivity.** The ability of a material to resist passage of electrical current either through its bulk or on a surface. The unit of volume resistivity is the ohm-cm, of surface resistivity, the ohm.

Roentgen. The amount of radiation that will produce one electrostatic unit of ions per cubic centimeter volume.

Schering Bridge. An alternating current form of wheatstone bridge, used for comparing capacitances or for measuring the phase angle of a capacitor by comparison with a standard capacitor.

Semiconductor. A material whose resistivity is between that of insulators and conductors. The resistivity is often changed by light, heat, an electric field, or a magnetic field. Current flow is often achieved by transfer of positive holes as well as by movement of electrons. Examples include germanium, lead sulfide, lead telluride, selenium, silicon, and silicon carbide. Used in diodes, photocells, thermistors, and transistors.

Sheet. Any material (conducting, insulating, or magnetic) manufactured in sheet form and cut to suit in processing.

Shelf Life. Length of time under specified conditions that a material retains its usability.

Silicone. Polymeric materials in which the recurring chemical group contains silicon and oxygen atoms as links in the main chain.

Solvent. A liquid substance which dissolves other substances.

Sparkover. A disruptive discharge between electrodes of a measuring gap, such as a sphere gap or oil testing gap.

Specific Gravity. The density (mass per unit volume) of any material divided by that of water at a standard temperature.

Staple Fibers. Fibers of spinnable length manufactured directly or by cutting continuous filaments to short lengths.

Storage Life. The period of time during which a liquid resin or adhesive can be stored and remain suitable for use. Also called Shelf Life.

Surface Creepage Voltage. See Creepage.

Surface Flashover. See Flashover.

Surface Leakage. The passage of current over the boundary surfaces of an insulator as distinguished from passage through its volume.

Surface Resistivity. The resistance of a material between two opposite sides of a unit square of its surface. Surface resistivity may vary widely with the conditions of measurement.

Surge. A transient variation in the current and/or potential in a circuit.

Tear Strength. Force required to initiate or continue a tear in a material under specified conditions.

Tensile Strength. The pulling stress required to break a given specimen.

Thermal Conductivity. Ability of a material to conduct heat.

Tensile strength. The pulling stress required to break a given specimen.

Thermal Conductivity. Ability of a material to conduct heat.

Thermal Endurance. The time at a selected temperature for an insulating material or system of materials to deteriorate to some predetermined level of electrical, mechanical, or chemical performance under prescribed conditions of test.

Thermal Expansion (Coefficient of). The fractional change in length (sometimes volume) of a material for a unit change in temperature.

Thermoplastic. A classification of resin that can be readily softened and resoftened by heating.

Tracking. Scintillation of the surface of an insulator, may produce enough heat to leave a degraded track of carbon.

Tracking Resistance. See arc resistance.

Transfer Molding. A method of molding thermosetting materials, in which the plastic is first softened by heat and pressure in a transfer chamber, and then forced into a closed mold for final curing.

Tubing. Extruded non-supported plastic or elastomer materials.

Urea-Formaldehyde Resin. A synthetic resin formed by the reaction of urea with formaldehyde. An amino resin.

Urethane. See Isocyanate Resins.

Vinyl Resin. A synthetic resin formed by the polymerization of compounds containing the group $\text{CH}_2 = \text{CH}-$.

Viscosity. A measure of the resistance of a fluid to flow (usually through a specific orifice).

Volt. Unit of electromotive force. It is the difference of potential required to make a current of one ampere flow through a resistance of one ohm.

Voltage. The term most often used in place of electromotive force, potential, potential difference, or voltage drop, to designate electric pressure that exists between two points and is capable of producing a flow of current when a closed circuit is connected between the two points.

Volume Resistivity (Specific Insulation Resistance). The electrical resistance between opposite faces of a 1-cm cube of insulating material, commonly expressed in ohm-centimeters. The recommended test is ASTM D257-61.

Vulcanization. A chemical reaction in which the physical properties of an elastomer are changed by reacting it with sulfur or other cross-linking agents.

Water Absorption. Ratio of the weight of water absorbed by a material to the weight of the dry material.

Wire. A conductor of round, square, or rectangular section, either bare or insulated.

Working Life. The period of time during which a liquid resin or adhesive, after mixing with catalyst, solvent, or other compounding ingredients, remains usable.

Yield Strength. The lowest stress at which a material undergoes plastic deformation. Below this stress, the material is elastic; above it, viscous.

1. INTRODUCTION

One of the new challenges to the electrical insulation design engineer is the application of materials to high voltage, high power aircraft components. In aircraft, the space and volume constraints require that the high power components be miniaturized, yet be compatible with the airplane's thermal and mechanical environment. Added to these constraints and requirements are the traditional demands for minimizing weight with less insulation and less metal, and at the same time keeping costs realistic.

There can be no miracle insulation that has ideal electrical, thermal, and structural properties. Therefore, the insulation engineer must recognize that each application has its own set of optimum insulations that satisfy all the electrical performance, environmental, and structural constraints. For example, capacitors require materials with high dielectric constants, whereas insulators and feedthroughs require good structural properties with low dielectric constant. For insulation applications other than capacitors, a low dielectric constant is generally preferred because it has low charging current. Insulators for solid state devices have a different and unique requirement --- a heat transfer rate which is usually not associated with low electrical conductivity. These examples show that the design engineer is always evaluating compromises when choosing electrical insulation.

An insulation, before being adopted, should be evaluated by test. Tests should include: (1) temperature cycling in the atmosphere in which it is to be operated, (2) high voltage evaluation, (3) measurement of dielectric constant and loss factor, (4) verification of tracking characteristics, (5) surface resistivity measurements, (6) voltage breakdown measurement, (7) development of models configured to represent the application, otherwise the effects of mechanical stress and the environments will not be correctly tested, (8) exposure to environment, and (9) application of mechanical stresses. These tests will provide some assurance of reduced infant mortality of the final assembly.

1.1 Definition of "Insulation". The purpose of electrical insulation is to physically separate the electromagnetic field boundaries. The insulation

must be composed of materials which have very high resistivity in order to restrict the flow of leakage current between conductors.

Gaseous, liquid, and solid insulations are in use. An insulation system may consist of a single material, a composite structure such as a laminate, or a combination of materials like a cable insulation system having layers of different materials. Electrical insulation encompasses the terms "dielectrics" and "insulators." A "dielectric" is a discrete material or class of material with a high resistivity. It is a non-metal used for isolating electrodes. An "insulator" is a generic expression for a solid material used to mechanically support and electrically isolate one or more conducting elements.

1.2 Design Guide Content. Field theory and theoretical aspects of a gaseous breakdown, insulating materials, and high voltage applications are comprehensively treated in textbooks and technical papers. Applicable portions of this theory will be reviewed, and references where further detail can be found will be noted.

Much of this document is devoted to design techniques associated with electric fields. Partial discharges caused by the inclusion of voids in dielectrics is treated --- application as well as the theoretical aspects of a perfect hole embedded in an ideal block of insulation is discussed. The effects of external gas pressure and of the gas content within the voids is also discussed for specific applications.

Electric properties of insulation are discussed. Specifically, (1) dielectric strength, (2) resistance to corona, creepage and tracking, (3) voltage gradients generated between various electrode configurations, and (4) the utilization factors plotted for the most common electrode configurations. All these data are useful for quick preliminary evaluations of insulation designs.

One of the last two sections in this guide describes testing, test equipment, and the use of incipient failure detection devices. The other section lists common failure mechanisms associated with equipment insulation and possible solutions. Sources of more detailed data and analytical techniques are cited throughout the text.

2. BACKGROUND

There are three important procedures for high density, high voltage, high power airborne equipment dielectric design and packaging. These procedures are:

- The design should make use of high quality materials designed within the electrical and mechanical stress limits of the materials.
- Circuit and component materials should be modeled and proven adequate for the design by electrical and mechanical testing. These tests should be used to determine the electrical, mechanical, and chemical characteristics and compatibility of parts and equipment and not as a failure tool after insulation failure.
- All parts, components, and assemblies should be fabricated in clean rooms by personnel knowledgeable in clean room procedures.

2.1 Program Plan and Requirements. High voltage high power equipment in future airplanes will operate in the 3,000 to 250,000 volt region, which is considerably higher than previously experienced in aircraft equipment. The consequences of a high-voltage breakdown on a mission need not be elaborated on here. The important point is that every high-voltage insulation failure in the past could have been prevented by thoroughly specified requirements, carefully conducted design, and adequate and properly planned testing to demonstrate that all requirements are met. Particularly troublesome are interfaces where equipment and responsibilities meet.

High-voltage circuit and component insulation must be analyzed by specialists, particularly when temperature cycling, high-density packaging and high-power equipment are involved. For example, consider components which are subjected to environmental and electrical testing prior to flight. During testing, the components may be electrically overstressed, connected and re-connected, the cables flexed and vibrated, and occasionally some parts may be exposed to hostile fumes and temperatures. These mechanical, chemical, and electrical stresses degrade electrical insulation. The specialist must show by analyses, tests, or test similarities, that stressing produces insignificant materials degradation and has little impact on the life of the insulation. Improperly tested components must be further analyzed and/or retested to show flightworthiness.

It is essential that the (1) insulation materials, (2) test requirements, and (3) specifications be developed prior to hardware fabrication.

2.2 Requirements Specification. Each item of equipment in an airplane must (1) perform its function, and (2) not interfere with other equipment or systems on the airplane or a companion airplane, when two or more airplanes are involved. For a mission to be successful from both standpoints, the equipment must be correctly specified and must meet specified requirements.

An important initial part of a high-voltage high-power design is the specification of requirements which defines the mission temperature-pressure profile, operating time, voltages, types of enclosures, and the electrical characteristics of nearby materials and equipment. Included must be the testing, storage, and all pertinent military, NASA, and public standards and specifications.

Occasionally, a specification or standard has inadequate electrical or environmental test requirements. Then deviations, deletions, and/or additions must be written. For example, the tests in the military specification for transformers ¹, MIL-T-27, are inadequate to ferret out pinholes and voids in the electrical insulation of low voltage transformers and inductors.

2.3 Planning a High-Voltage Program. A program plan is a necessary element that bridges the requirements specification to the specifications that define the system, equipment and circuits as shown in Figure 1. This program plan should include pre-flight testing, storage, and airplane constraints.

A good high voltage program plan includes a requirements plan and a design-and-test-plan. The requirements plan (Figure 2) includes evaluation of historical data applicable to the equipment and the airplane, operational constraints, and the test and test equipment requirements. Historical data for aerospace equipment operating at voltages up to 10 kilovolts is abundant.² Likewise, materials, designs, and manufacturing techniques for this voltage region are

1. "Transformers and Inductors (Audio, Power, and High-Power Pulse) General Specification Form", MIL-T-270, April, 1974
2. J. E. Sutton and J. E. Stern, "Spacecraft High Voltage Power Supply Construction," NASA TR D7948, Goddard Space Flight Center, Greenbelt Md., April, 1975

readily available. For voltages over 10 kilovolts information is scarce, and research and development tailored to the constraints and requirements unique to the airplane and equipment aboard the airplane is often needed.

High voltage testing becomes hard to define for several reasons. First, the supplier of electronic components may lack some test equipment or test experience within his design organization, necessitating compromises in the hierarchy of testing; second, there are several levels of testing to be performed with difficult-to-evaluate options on when to perform what tests; third, test equipment sensitivity is affected by the equipment being tested and the connection thereto. Some equipment and experiments can actually be designed to test themselves. All these elements must be defined in the requirements plan by the equipment designer, and his customer, before preliminary design review.

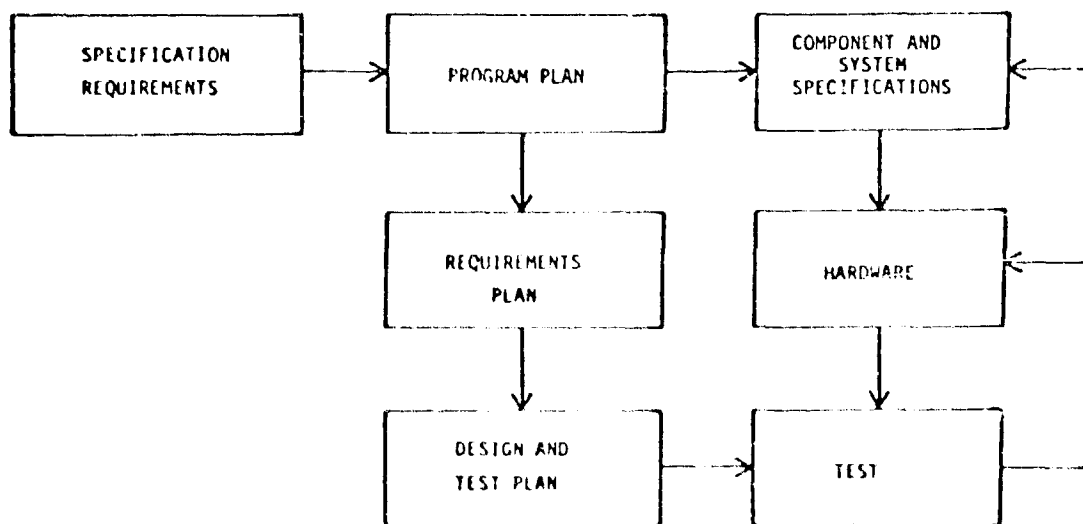

FIGURE 1. HIGH-VOLTAGE, HIGH-POWER SYSTEM DEVELOPMENT PLAN

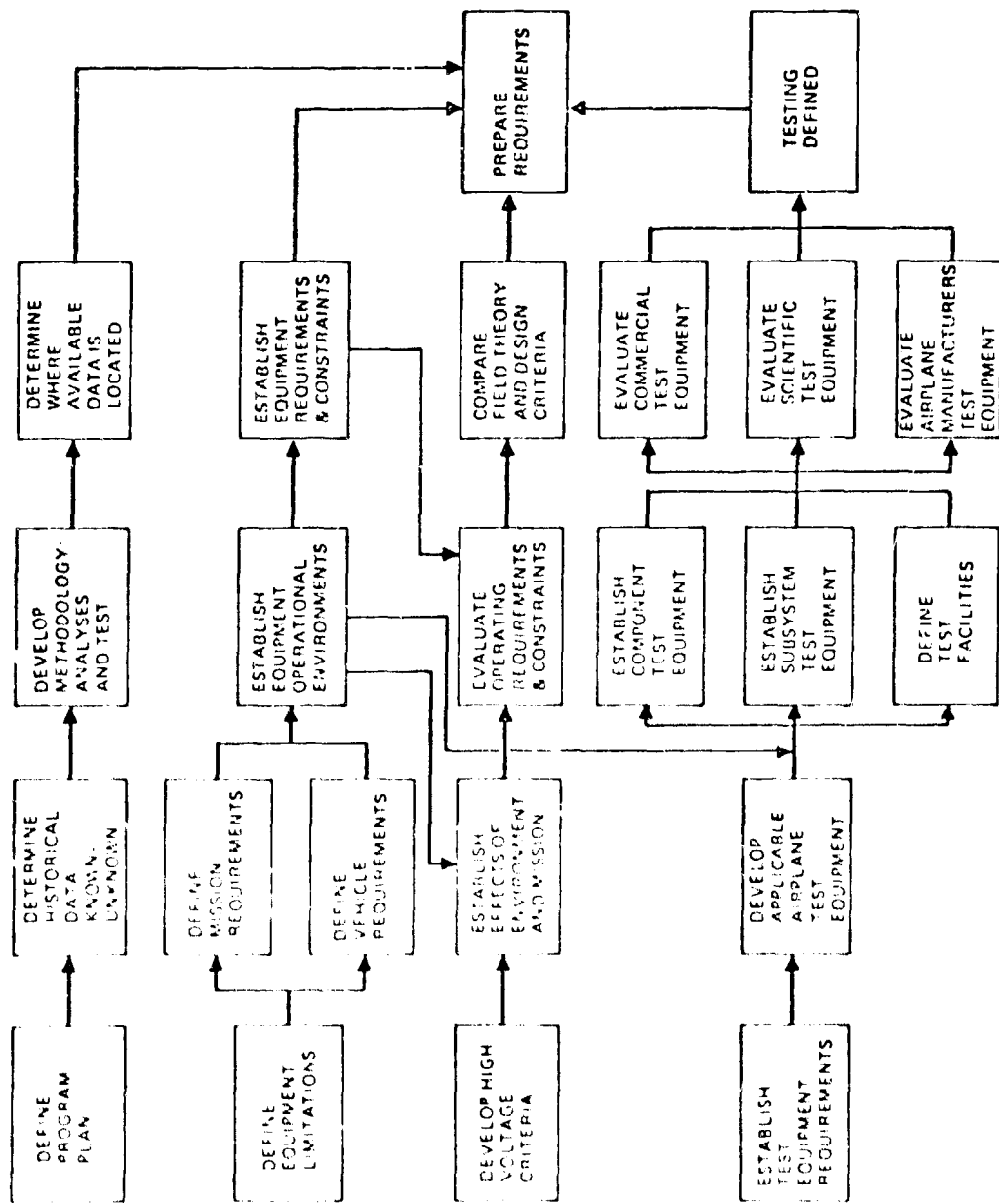

FIGURE 2. REQUIREMENTS PLAN

2.4 Design-and-Test Plan. A design-and-test plan should be developed for each high voltage component aboard the airplane. It should contain the constraints and requirements that affect the design; for example, pressure, temperature, and outgassing products other than air.

Testing should be time sequenced with other phases of the high voltage system development such as design, materials selection and application, and packaging, to avoid delays and costly overruns from improper application of a specific material. The design and test plan, shown in Figure 3, requires that the insulating and conducting materials be selected and tested early in the program to establish their adequacy and life-stress capability.

Dense parts packaging, where mechanically stressed insulation must withstand wide temperature variations, are particularly important to watch. Some insulations crack when subjected to temperatures lower than -20°C , and with high electric fields between parts, cracked insulation is a precursor to partial discharges and ultimate failures.³

3. W.G. Dunbar, "High Voltage Connections for Flight Vehicles," Proc. 9th Intersociety Energy Conversion Engineering Conference, San Francisco, California, August 1974, pp 251-253

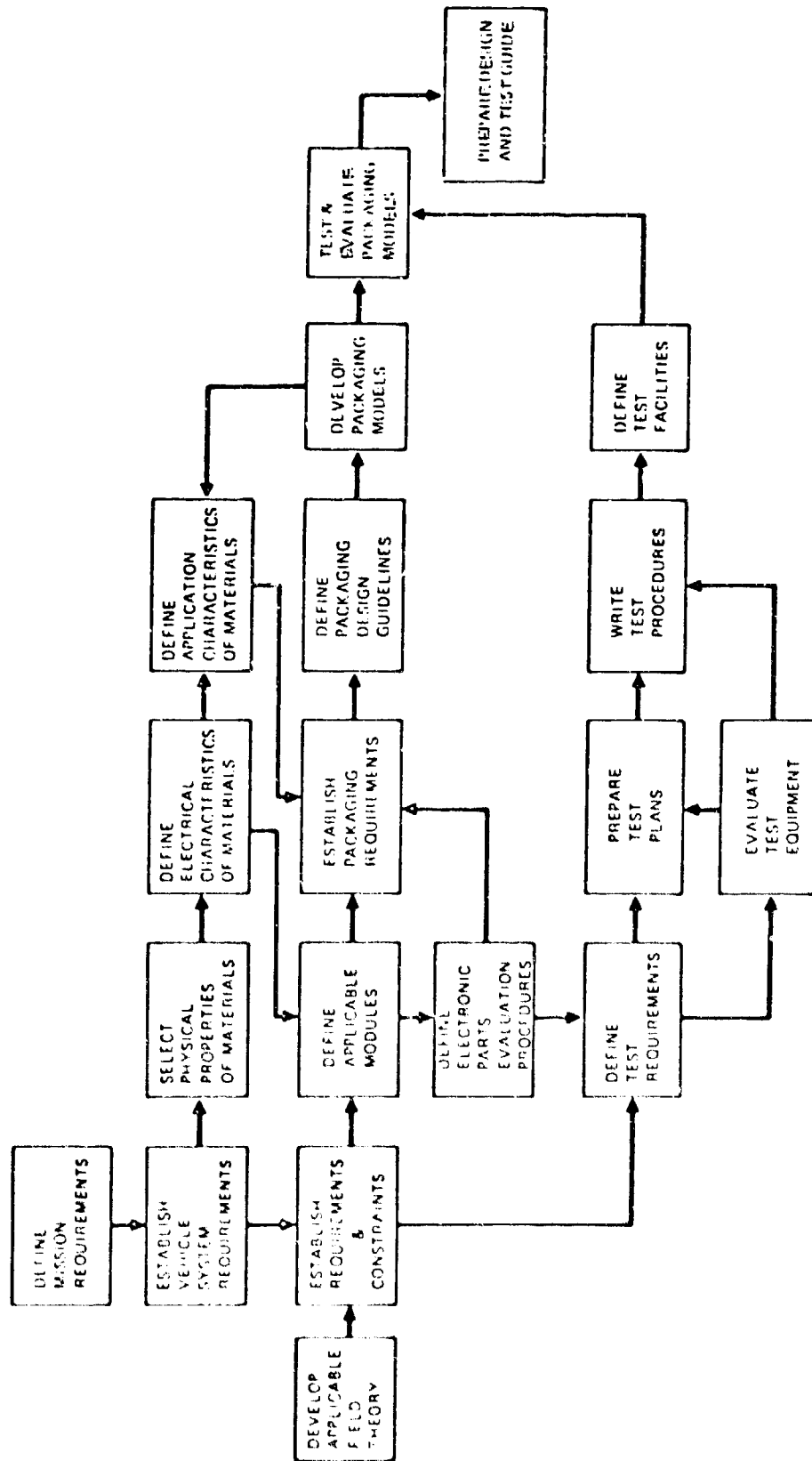

FIGURE 3. DESIGN AND TEST PLAN

3. FUNDAMENTALS OF INSULATIONS

Changes in insulation properties resulting from electric field and temperature variations, mechanical stress, and surface contact with electrodes are fundamental contributors to voltage breakdown. The designer dealing with these changes in insulation properties needs to understand certain fundamental characteristics of insulation behavior. Basic theory of gas, liquid, and solid insulation is provided to an appropriate depth in this section. Excellent texts on dielectric phenomena are listed as References 4 through 8.

3.1 Gases. Much has been written about the theory of gas breakdown, and data obtained under a variety of conditions has been published (References 9 through 17). A brief review and discussion of this theory follows.

- 4) W.R. Smythe, Static and Dynamic Electricity, McGraw-Hill Book Co., New York, N.Y., 1968.
- 5) J.D. Stratton, Electromagnetic Theory, McGraw-Hill Book Co., New York, N.Y., 1941.
- 6) E. Weber, Electromagnetic Fields, John Wiley and Sons, Inc., New York, N.Y., 1950.
- 7) A.R. Von Hippel, Dielectric Materials and Application, John Wiley and Sons, Inc., 1954.
- 8) E.W. Greenfield, Introduction to Dielectric Theory and Measurements, College of Engineering, Washington State University, Pullman, Washington, 1972.
- 9) J.M. Meek and J.D. Craggs, Electrical Breakdown of Gases, Oxford University Press, AmenHouse, London, England, 1953.
- 10) L.B. Loeb, Electrical Coronas, University of California Press, Berkeley, California, 1965.
- 11) J.D. Cobine, Gaseous Conductors, New York, New York, Dover, 1958.
- 12) A. Von Engel, Ionized Gases, London, Oxford University Press, 1955.

J.S. Townsend proposed his theory of gas breakdown in the early 1900's.¹⁸ Much has since been added, but his original work is still the basis for most studies.

When an electrical potential is impressed across a gas, a small pre-breakdown current can be measured because free electrons drift from the cathode or negative electrode to the anode or positive electrode. At low potential the apparent circuit resistance is high because the electrons collide with neutral gas molecules in the gap. Some electrons find their way to the anode due to the elasticity of the collisions. As the potential is raised, electron velocity is increased, and some electrons gain sufficient energy to ionize the gas by collision, separating molecules into new free electrons and positive-ion pairs. The new free electrons are accelerated and ionize more molecules generating electrons at an exponential rate with respect to applied voltage. This process, called avalanche breakdown of the gas, is shown in Figure 4, where the pre-breakdown current is labeled "recombination." Recombination is where the electrons released from a cathode by background radiation, for example, a cosmic ray, tend to return to the cathode by back diffusion and because of the space charge field. The region labeled "secondary ionization" is where the initiating electrons (N_0) cause α ionizations per unit distance traveled through the field. The number

- 13) F.L. Jones, Ionization and Breakdown of Gases, John Wiley and Sons, New York, New York, 1957.
- 14) F. Llewellyn-Jones, The Glow Discharge, Methuer and Co., Ltd., London, England, 1966.
- 15) L.B. Loeb, Basic Processes of Gaseous Electronics, 2nd Edition, University of California Press, Berkeley, California, 1960.
- 16) F.M. Penning, Electrical Breakdown of Gases, MacMillan Company, New York, N.Y., 1957.
- 17) G.P. Thomson, Conduction of Electricity Through Gases, Cambridge University Press, Vol. 2, 3rd Edition, London, England, 1928.
- 18) J.S. Townsend, Electricity in Gases, Oxford University Press, London, England, 1914.

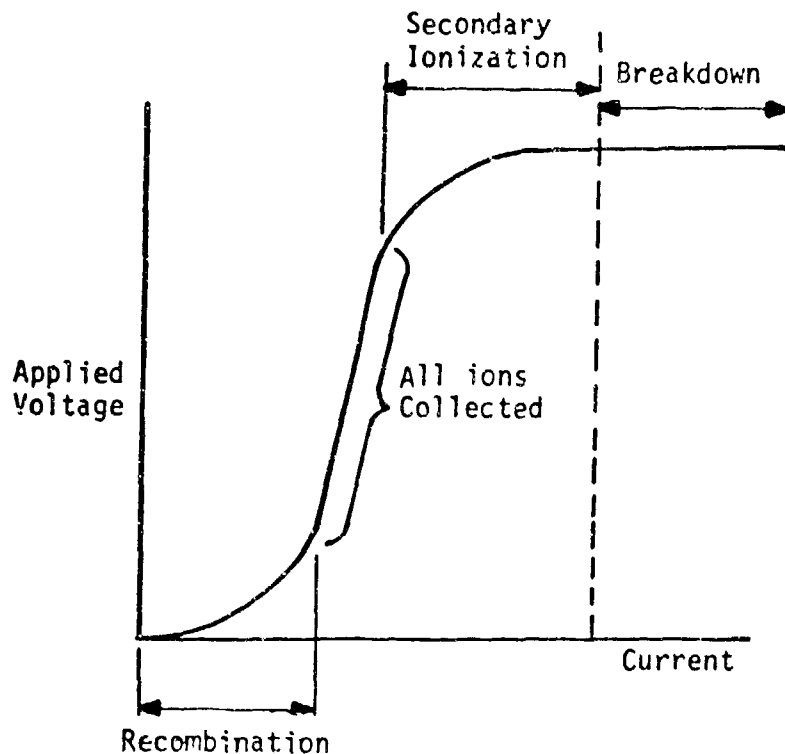

FIGURE 4. VOLTAGE-CURRENT CHARACTERISTIC FOR A GAS IN A UNIFORM ELECTRIC FIELD

of electrons (N) reaching the anode at a distance d is then

$$N = N_0 e^{\alpha d} \quad (3.1)$$

Further increase in applied voltage puts us in the breakdown region where additional electrons are released principally by positive ion bombardment of the cathode. This condition is described by the sequence of events shown in Figure 5.¹⁹ Townsend's criterion for breakdown is

$$\gamma(e^{\alpha d} - 1) = 1 \quad (3.2)$$

19) W.H. Krebs and A.C. Reed, "Low Pressure Electrical Discharge Studies", STL/TR-59-0000-09931, Air Force Contract 04(647)-309, December 1959.

Where γ is the secondary Townsend coefficient and δ is the path in the direction of the field in centimeters.

Three mechanisms for releasing electrons from a cold cathode are:

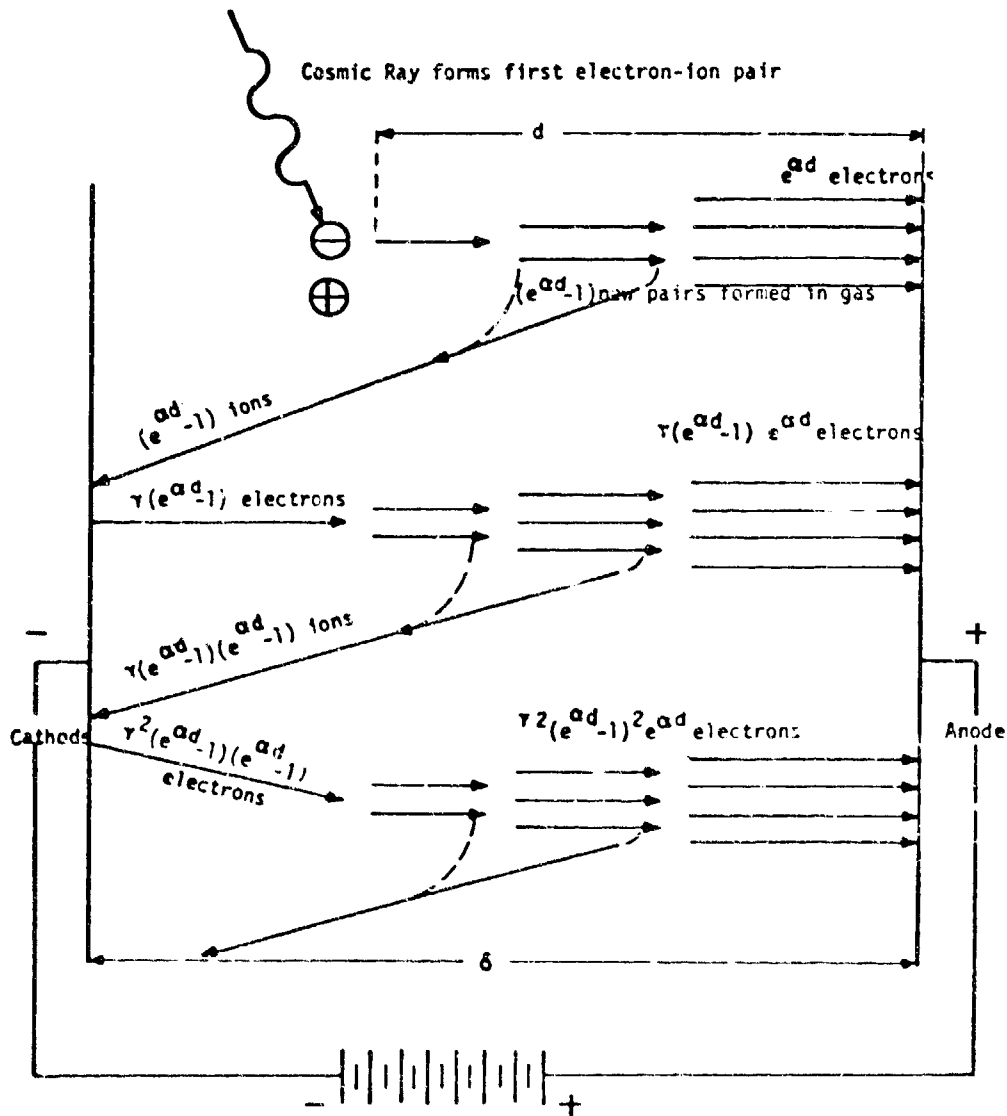

FIGURE 5. DERIVATION OF TOWNSEND'S BREAKDOWN CRITERION

- o Arriving positive ions strike the cathode.
- o Light radiation falls on the cathode.
- o Light results from excitation of molecules by collision with electrons which do not have enough energy to produce ionization.
- o A metastable molecule, which evolved from an electron-molecule collision, diffuses back to the cathode (Figure 5).

3.1.1 Electronegative Gases. Elements having outer rings deficient of one or two electrons form molecules and compounds which are able to capture free electrons, forming heavy and relatively immobile negative ions. The negative charge of such an ion equals the number of free electrons captured. Gases forming such ions, called electronegative gases, have high dielectric strength because the heavy ions arrest the formation of electrical discharges normally initiated by mobile electrons. The number of attaching collisions made by one electron drifting one centimeter in a field is the attachment coefficient n . The criterion for breakdown in an electronegative gas is

$$\frac{\gamma \alpha}{\alpha - n} \left[e^{(\alpha - n) \gamma} - 1 \right] = 1 \quad (3.3)$$

Gases with oxygen and halogen atoms are electronegative and hence good insulators, in contrast to hydrocarbon and noble gases. Some electronegative gases are sulfur hexafluoride (SF_6) dichlorodifluoromethane (CCl_2F_2), perfluoropropane (C_3F_8), perfluorobutane (C_4F_{10}), hexafluoroethene (C_2F_6), chloropentafluoroethene (C_2ClF_5), dichlorotetrafluoroethane ($\text{C}_2\text{Cl}_2\text{F}_4$), and tetrafluoromethane (CF_4).

These gases are chemically inert and have good thermal stability, but can decompose chemically when exposed to partial discharges or arcs. The products of decomposition are often toxic and corrosive.

3.1.2 Corona. Loch¹⁰, describes the phenomena of corona in the following manner. "Except at relatively low pressures, the luminous manifestations at the highly stressed electrode near the threshold for the low currents take on various characteristic shapes, such as flows, multiple

spots, haloes, coronas, brushes, streamers, etc. In consequence, these luminous manifestations gave to the phenomena the general name, coronas. It comes from the French word couronne, literally crown, which typifies one of the various forms observed. This expression, corona, will be used to describe the general class of luminous phenomena appearing associated with the current jump to some microamperes at the highly stressed electrode preceding the ultimate spark breakdown of the gap. Where observed, the sudden current jump, usually just preceding the initial appearance of the corona and the associated value of the potential, will be designated as the corona threshold. The threshold for the appearance of a corona form may be further classified in terms of the characteristic phenomenon or mechanisms associated with it, such as the burst pulse threshold, the streamer threshold, the Trichel pulse threshold, or the glow discharge threshold. The current at many such thresholds is pulsating or intermittent in nature. Depending on the geometry and the spectroscopic nature of the gas, the intermittent or pulsed thresholds may not show luminosity in all cases. If the potential is raised on the order of some hundreds of volts above threshold, the frequencies of the intermittent pulses become so great that they merge to a nearly steady but slightly fluctuating current. Transition from intermittent to the steady state is sometimes sharp and is described as the onset of steady corona. Above the onset of steady corona there will be a limited region, in which current increases nearly proportional to potential increase. This is called the Ohm's law regime. After this the current increases more rapidly than potential, that is, parabolically, eventually leading to a complete spark breakdown, which will be so designated."

Corona is reserved for discharges in gases around a conductor, bare or insulated, remote from any other conductor. Corona should not be confused with partial discharges, ionization or breakdown. Partial discharges are electric discharges which only partially bridge the insulation between conductors. These discharges may, or may not, occur adjacent to a conductor. Ionization describes any process producing positive or negative ions, or electrons, from neutral atoms or molecules and should not be used to denote partial discharges.

3.1.3 Paschen Law. The breakdown voltage of a uniform-field gap in

a gas can be plotted to relate the voltage to the product of the gas pressure times the gap length. This is known as Paschen's law curve.¹⁰ The law may be written in the general form

$$V = f(\rho d)$$

where ρ is the gas density, and d is the distance between parallel plates.

In words, Paschen's law states: "As gas density is increased from standard temperature and pressure, the voltage breakdown is increased because at higher densities the molecules are packed closer, and a higher electric field is required to accelerate the electrons to ionizing energy within the mean free path. The voltage breakdown decreases as gas density is decreased from standard pressure and temperature because the longer mean free path permits the electrons to gain more energy prior to collision. As density is further decreased, the voltage breakdown decreases until a minimum is reached."

As density is further reduced to values less than the Paschen law minimum, the voltage breakdown rises steeply because the spacing between gas molecules becomes so large that although every electron collision produces ionization, it is hard to achieve enough ionizations to sustain the chain reaction. Finally, the pressure becomes so low that the average electron travels from one electrode to the other without colliding with a molecule. This is why the minimum breakdown voltage varies with gas density and spacing. Examples of Paschen-law curves for several gases are shown in Figure 6.

The pressure corresponding to minimum breakdown depends on the spacing of the electrodes; for a 1-centimeter spacing at room temperature this pressure occurs at about 100 Pascals. One Pascal is equal to one newton per square meter or 7.5×10^{-3} torr. A representative minimum for air is 326 volts d.c. For a contact spacing of one centimeter at standard atmospheric conditions the breakdown voltage is 31 kilovolts.

Voltage breakdown, under normal conditions, has no sharply defined starting voltage because its initiation depends on an external source of

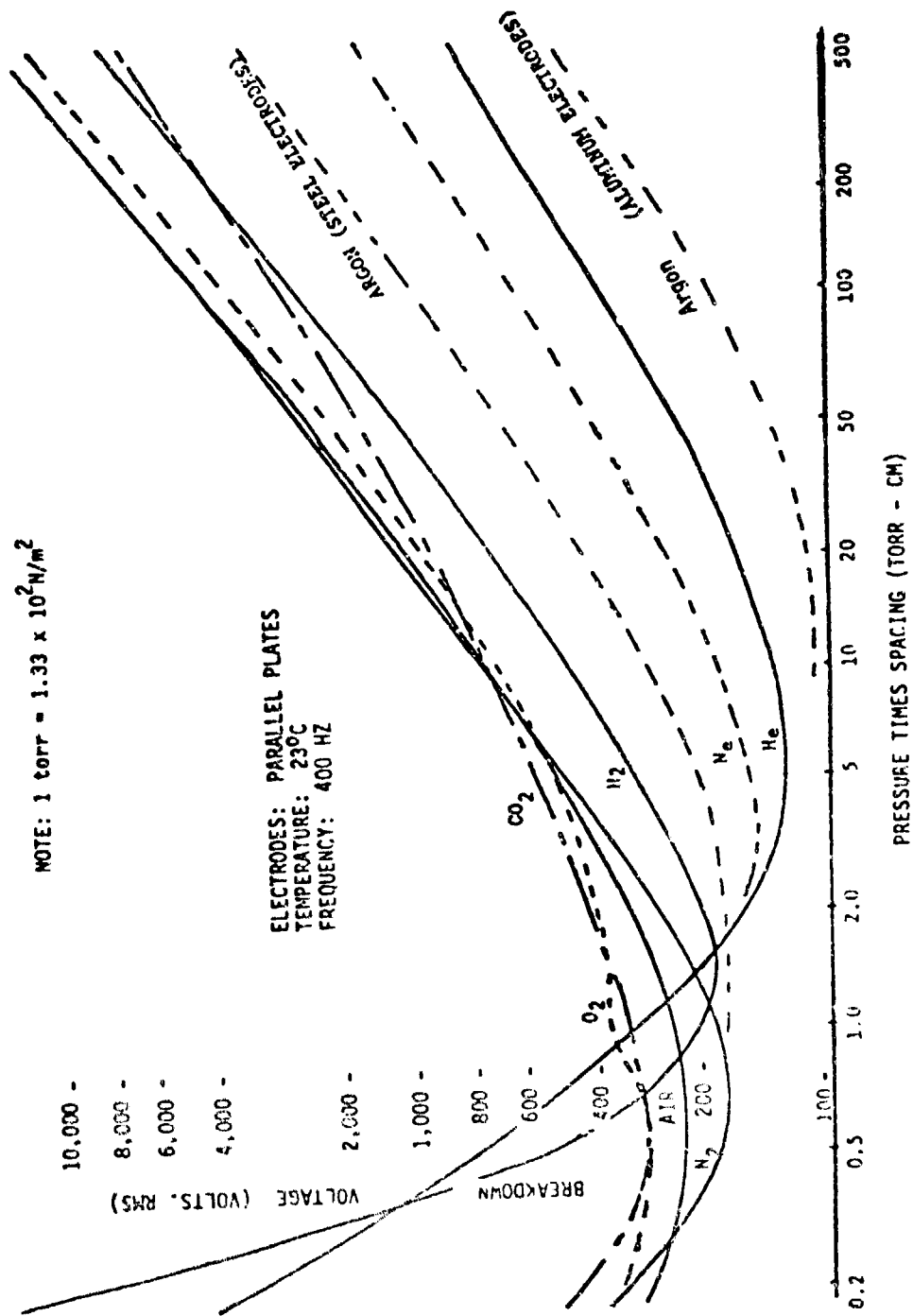

FIGURE 6. VOLTAGE BREAKDOWN OF PURE GASES AS A FUNCTION OF PRESSURE TIMES SPACING

ionization. There is generally a time delay between the application of voltage and breakdown. This time delay varies statistically and is a function of the difference between the applied voltage and the "critical voltage." Ultra-violet and higher-energy radiation will reduce the time delay considerably.

Paschen-law curves for non-uniform fields become difficult to predict because the effective gap length is not easily defined.

3.1.4 Penning Effect. Penning¹⁶ discovered that if a trace (much less than one percent) of a gas such as argon was mixed into a gas such as neon, a large reduction in the breakdown voltage occurred. This is caused by the metastable neon atoms ionizing the argon atoms. Gas mixtures having this characteristic are helium-argon, neon-argon mixtures, helium-mercury, and argon-iodine. Airplane compartments containing helium must be kept free of argon to prevent the possibility of low voltage breakdown.

3.1.5 Breakdown of Gases. Of the gases proposed for pressurizing electrical equipment some can be rejected on the basis of low breakdown voltage, and others on the basis of toxic or corrosive decomposition products. The potentials required for voltage breakdowns in gases at the minimum pressure-spacing condition (Paschen-law minimum) and between parallel plates spaced one centimeter apart at pressure, are listed in Table 1.

Of these gases sulfur hexafluoride is generally the preferred gas because it is stable, electronegative, and easily obtained. Sulfur hexafluoride (SF_6) gas is used in compact switching equipment, substations, cables, and other commercial high voltage equipment. It should be the first gas considered for high-voltage airplane equipment when component density and other criteria suggest that a gas-pressurized installation is best.

Non-Uniform Fields. The utilization factor is defined as the ratio of the average to the maximum gradient across a gap. The minimum sparkover for a non-uniform field, V_s , is given by the relationship

$$V_s = \eta g E_s \quad (3.4)$$

Where E_s is the sparkover gradient and g is the gap dimension. Where η is a function of the electrode geometry and material, and can be calculated for practical configurations such as shown in Figure 7. An example of a breakdown-voltage curve is shown in Figure 8. Equations for the breakdown of SF_6 between the electrodes in Figure 7 are given in Tables 2 and 3. The equations in Table 2 are empirical, except for equations 8 and 9 which were theoretically derived.^{20,21} Experimental work by Azer and Comsa²² developed the effect of radius of

TABLE 1
BREAKDOWN VOLTAGE BETWEEN BARE ELECTRODES SPACED
ONE CENTIMETER

<u>Gas</u>	<u>Minimum at Critical Pressure Spacing</u>		<u>Breakdown Voltage at 1 Atmosphere</u>	
	<u>Volts (a.c.rms)</u>	<u>Volts (d.c.)</u>	<u>Kilovolts (a.c.)</u>	<u>Kilovolts (d.c.)</u>
Air	223-230	315	23	33
Ammonia	---	---	18.5	26
Argon	196	280	3.4	4.8
Carbon Dioxide	305	430	24	28
Freon 14	340	480	22.8	32
Freon 114	295	420	64	90
Freon 115	305	430	64	90
Freon 116	355	500	--	--
Freon C 138	320	450	--	--
Helium	132	189	1.3	1.63
Hydrogen	205	292	12	17
Nitrogen	187	265	22.8	32
Oxygen	310	440	--	--
Sulfur hexafluoride	365	520	67	95

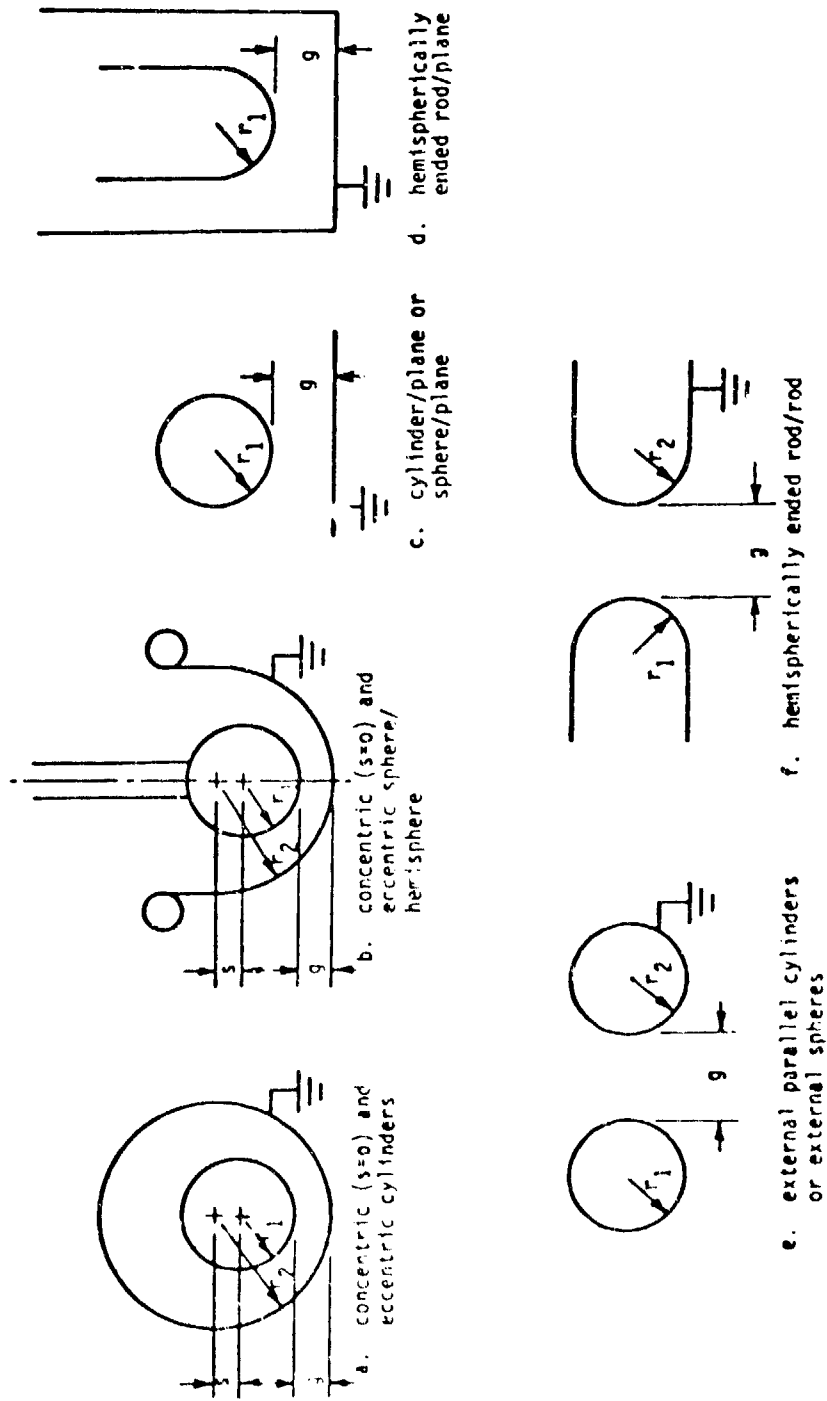

FIGURE 7. ELECTRODE GEOMETRIES

TABLE 2

PUBLISHED EQUATIONS FOR SPARKOVER GRADIENTS E_S IN SF₆

Pressure $p \times 10^5 \text{N/cm}^2$	Electrode Geometry (see Fig. 6)	Range of Dimensions mm (see Fig. 6)	Voltage Waveform	Equation E KV/mm See note
$1 < p < 4$	concentric cylinders	$2.5 \leq r_1 \leq 25$ $30 \leq r_2 \leq 140$	50 Hz	(1) $E = 5.3(1+0.459p) / (1+(2.92-2.29/p)\sqrt{r_1})$
$1 < p < 4$	concentric cylinders	$19 \leq r_1 \leq 100$ $100 \leq r_2 \leq 270$	50 Hz negative impulse	(2) $E = 4.28p+3.8$ (3) $E_c = 6.43p+3.0$
			negative impulse	(4) $E = 4.59p+3.5$
	sphere/sphere	$r_1 = r_2 = 125$ $20 \leq g \leq 80$	50 Hz	(5) $E = 6.12p+2.3$
			negative impulse	(6) $E = 6.74p+2.6$
$1 < p < 4$	concentric cylinders	not specified but expected to be $19 \leq r_1 \leq 100$ $100 \leq r_2 \leq 270$	positive impulse	(7) $E = 8/12p+1.0$
$1 < p < 6$	sphere/plane	$10 \leq r_1 \leq 25$ $20 \leq g \leq 500$	positive impulse	(8) $E = 8.78p + \text{correction factor}$
$1 < p < 5$	sphere/sphere	$r_1 = r_2 = 75$ $0 \leq g \leq 120$	50 Hz	(9) $E = 8.78p / (1+0.557/\sqrt{pr_1})$
	hemispherically ended rod/rod	$r_1 = r_2$ $5 \leq r_1 \leq 15$ $0 \leq g \leq 200$		

TABLE 3
SPARKOVER GRADIENTS IN AIR

Pressure $\mu/m^2 \times 10^5$	Electrode Geometry (See Fig. 6)	Range of Dimension mm (See Fig. 6)	Voltage Waveform	Equation E_s in kV/mm	Typical Error Range
1.013	concentric cylinders	$0.59 \leq r_1 \leq 15.9$ r_2 not specified	50 Hz (1)	$E_s = 3.1(1 + 0.975\sqrt{r_1})$	+ 1.4 - 5.4
1.013	concentric cylinders	$3.96 \leq r_1 \leq 38.1$ $r_2 = 290.5$	50 Hz (2)	$E_s = 2.2(1 + 1.71/\sqrt{r_1})$	
1.013	concentric cylinders	not specified	50 Hz (3)	$E_s = 2.4(1 + 1.49/(r_1)^{0.4})$	
1.013	concentric cylinders		50 Hz (4)	$E_s^2 = 4.56E_s \ln(4.39E_s)$ $= 5.2 + 0.24/r_1$	
1.013	concentric cylinders eccentric cylinders	$10 \leq r_1 \leq 150$ r_2 not specified $12.7 \leq r_1 \leq 38.1$ $r_2 = 61.5$ $5 \leq r_2 \leq (r_2 - r_1)$	50 Hz (5)	$E_s = 2.72(1 + 1.55/\sqrt{r_1})$	± 3.5 ± 3
$1 < P < 5$	concentric cylinders	$25.4 \leq r_1 \leq 80$ r_2 not specified	50 Hz (6)	$E_s = 2.12(1 + 3.55\sqrt{P} \times 10^{-5})$	± 4
1.013	concentric sphere/ hem. sphere eccentric sphere/ hemisphere	$5 \leq r_1 \leq 125$ $72.5 \leq r_2 \leq 203.2$ $8.75 \leq r_1 \leq 38.1$ $r_2 = 72.5$ $0 \leq r_2 \leq 0.5(r_2 - r_1)$	50 Hz (7)	$E_s = 2.4(1 + 3.16/\sqrt{r_1})$	± 4
1.013	parallel external cylinders	$r_1 = r_2$ $0.098 \leq r_1 \leq 4.64$	50 Hz (8)	$E_s = 2.98(1 + 0.95/\sqrt{r_1})$	+ 3.7 - 6.2

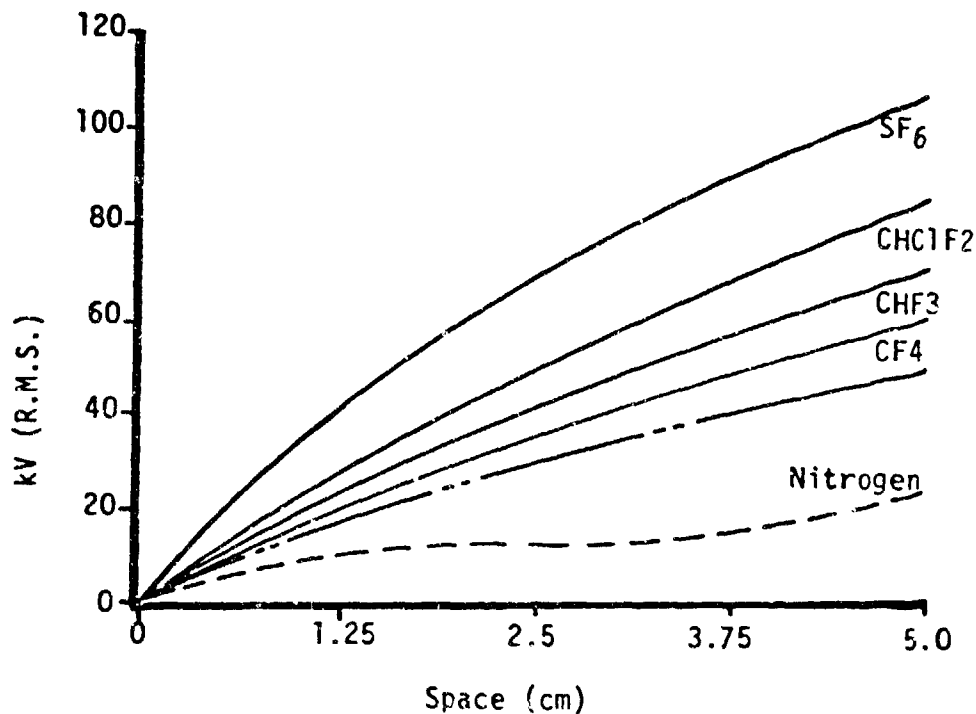

FIGURE 8. BREAKDOWN VOLTAGE CURVES OF GASES BETWEEN A HEMISPHERICALLY-ENDED ROD, OF 0.1 IN. DIAMETER, AND A SPHERE OF 1.0 IN. DIAMETER. THE GAS PRESSURE IS 1 ATM.

curvature on the breakdown voltage of SF₆ between 2 centimeter round rods. Breakdown curves from their work appears in Figure 9.

- 20) J.M. Mattingley and H.M. Ryan, "Correlation of Breakdown Gradients in Compressed Air and SF₆ for Nonuniform Fields," Conf. on Elec. Insulation and Dielectric Phenomena, 1973 Annual Report, National Academy of Sciences, Washington, D.C., 1973 pp 222-233.
- 21) I.D. Chalmers and D.J. Tedford, "Spark Breakdown Phenomena in Air and SF₆ at High Values of pd", Conf. on Elec. Insulation and Dielectric Phenomena, 1971 Annual Report, National Academy of Sciences, Washington, D.C., 1971 pp 136-140.
- 22) A.A. Azer and R.P. Comsa, "Influence of Field Nonuniformity on The Breakdown Characteristics of Sulfur Hexafluoride", IEEE, Trans. on Elec. Insulation, Vol. EI-8, No. 4, Dec. 1973 pp 136-142

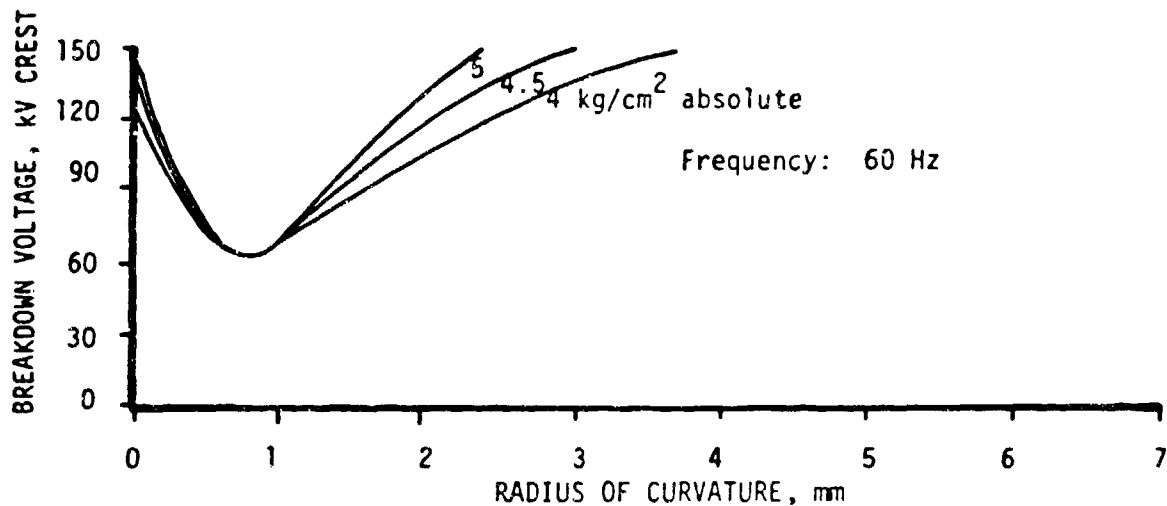

FIGURE 9, BREAKDOWN VOLTAGE AT 60 HZ

Dielectric coated electrodes have higher breakdown voltage than do bare electrodes.²³ Experimental Figures 10 and 11 show measured breakdown voltages for polyurethane-coated and anodized-aluminum electrodes for the gas pressures and thicknesses indicated. This technique for increasing breakdown voltage is not recommended unless the coating materials are given sufficient life testing and the coating process is held to a very tight tolerance. The use of coatings applied to the electrodes can be recommended for improving the safety margin. However, a coating that becomes unbonded will flake or blister, lowering the breakdown voltage to values lower than that of bare electrodes.

The effect of particles entrapped between electrodes was demonstrated by placing small spheres or short tubes between energized electrodes by Cookson and Wootton.^{24,25} Small lengths of copper between coaxial

23) D.J. Chee-Hing and K.D. Srivastava, "Insulation Performance of Dielectric-Coated Electrodes in Sulphur Hexafluoride Gas", IEEE, Trans. on Elec. Insulation, Vol. EI-10, No. 4, December 1975 pp 119-124.

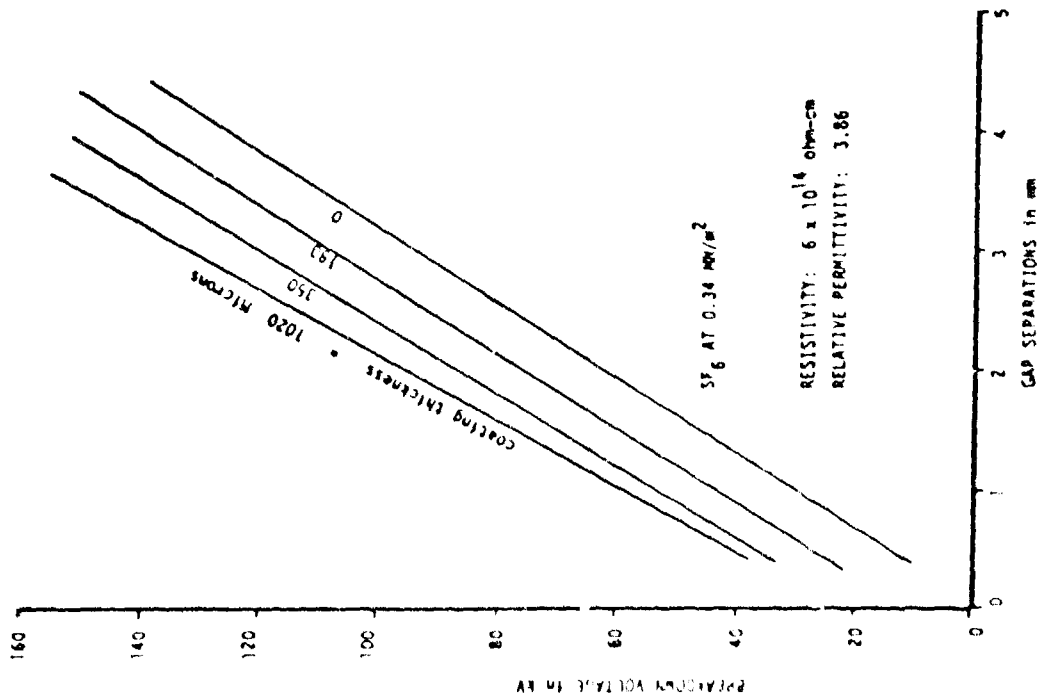

FIGURE 10. PERFORMANCE OF UNLOADED POLYURETHANE COATED ELECTRODES UNDER DC VOLTAGES

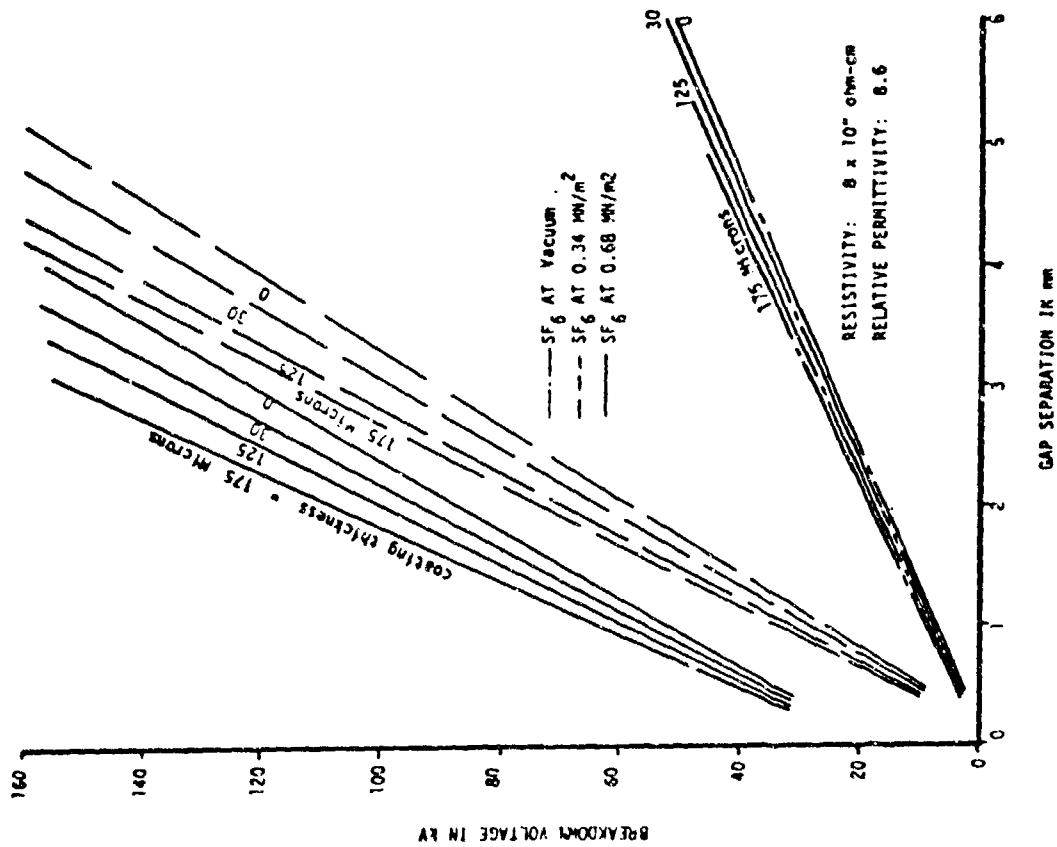

FIGURE 11. PERFORMANCE OF ANODIZED ALUMINUM ELECTRODES UNDER DC VOLTAGES

conductors (Figure 12) shows that the breakdown voltage decreases as the length is increased.

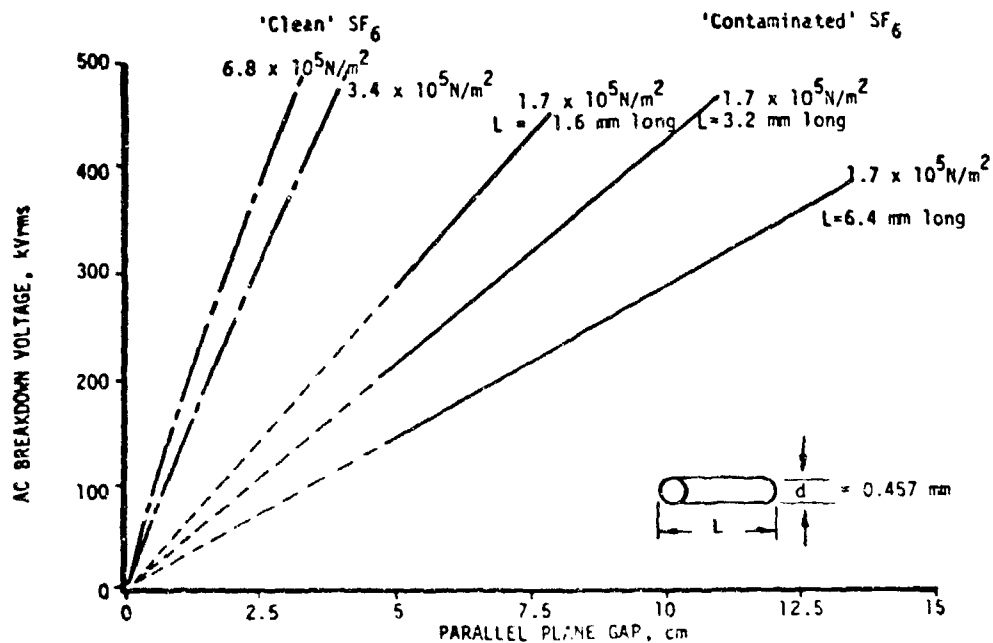

FIGURE 12. AC BREAKDOWN VOLTAGE-GAP CHARACTERISTICS IN SF₆ WITH COPPER PARTICLES OF VARIOUS LENGTH

This explains why small particulates between energized electrodes decrease the breakdown voltage significantly. In more recent work on the same subject²⁵, using nitrogen and SF₆ mixtures, they found that

- 24) A. H. Cookson and O. Farish "Motion of Spherical Particles and AC Breakdown in Compressed SF₆," Conf. on Elec. Insulation and Dielectric Phenomena, 1971 Annual Report, National Academy of Sciences, Washington, D.C. pp 129-135.
- 25) A. H. Cookson and R.E. Wootton, "Particle-Initiated AC and DC Breakdown in Compressed Nitrogen, SF₆, and Nitrogen-SF₆ Mixtures," Conf. on Elec. Insulation and Dielectric Phenomena, 1973 Annual Report, National Academy of Sciences, Washington, D.C. pp. 234-241.

the addition of 10 to 20% SF₆ to nitrogen raised the dielectric breakdown strength of the pressurized mixture to over 80 percent of that of pure SF₆. This phenomenon could reduce the cost of the insulating gas, if it holds true for lower pressures of N₂-SF₆ mixtures--say 2 to 4 atmospheres--which would be safe for airplane installations.

3.1.6 Voltage Transients and Time Lag. The statistical time lag is the time needed for a triggering electron to appear in a gas filled gap. The tip of a breakdown streamer travels at about 10⁸ cm/s. The return stroke is somewhat faster. This implies that streamer breakdown should occur within 10⁻⁷ s after application of breakdown potential, provided adequate triggering electrons are present.

The time to breakdown varies with applied voltage, the gas pressure, the electrode configuration, and the spacing between electrodes. Curves showing the ratio impulse voltage to steady-state breakdown voltage for three electrode configurations in air at one atmosphere pressure are shown in Figure 13. These curves show that very fast, short-duration transients (less than 10 nanoseconds) will not cause breakdown at over-voltages less than 150 percent of steady-state breakdown voltage. Slow transients (less than one microsecond duration) require 105 to 110 percent of steady-state voltage for breakdown. Thus, the transient voltage peak and duration are an important element in estimating the probability of breakdown between electrodes of known configuration.

3.2 Solid Insulation. Ideally, a solid insulation has no conductive elements, no voids or cracks, and has uniform dielectric properties. Practical insulations have thickness variations, may shrink with temperature and age, may have some deposited conductive elements, and their dielectric properties change with temperature, frequency, and mechanical stresses.

In aircraft applications the environmental and electrical stresses vary as a function of time; some independently, others dependent upon each other. These variations make it difficult to select an ideal insulation for a specific application. Furthermore, it isn't possible to extrapolate the operation of a second or third generation device based upon the perfor-

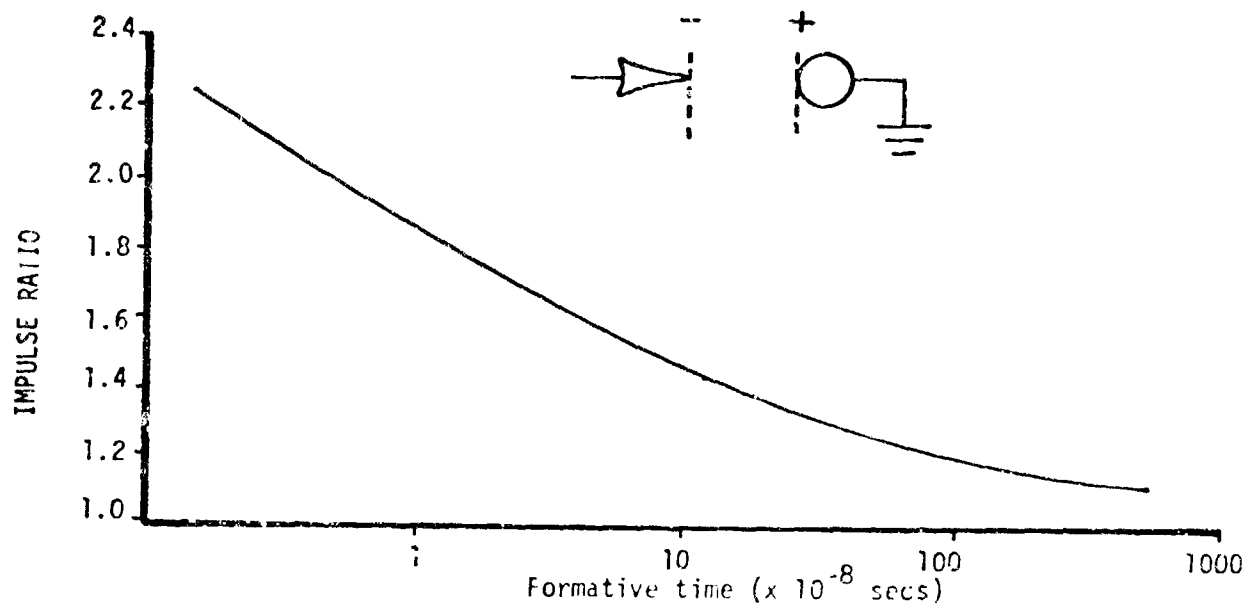

FIGURE 13. RELATION BETWEEN FORMATIVE TIME AND IMPULSE RATIO FOR VARIOUS GAP LENGTHS AND GAS PRESSURE IN A NEGATIVE POINT-SPHERE GAP IN AIR.

mance of a first generation device. For instance, the composition of materials varies from batch-to-batch, and the cleanliness and manner of handling and manufacturing in a production facility are not the same as in a prototype shop. All these matters must be considered when developing an insulation for a new high-voltage product.

The pertinent environmental and electrical characteristics of solid insulations are discussed below.

3.2.1 Materials Properties. Solid insulation has electrical, mechanical, thermal, and chemical properties. These and miscellaneous properties are detailed in Table 4. Sometimes materials are specified to be transparent so the performance engineer can assess parts stressing and bonding. Weight, water absorption, and outgassing are often specified. Most important for all categories of high-voltage insulation is life, which depends upon the electrical stress and environment.

TABLE 4

PROPERTIES OF INTEREST FOR INSULATING MATERIALS

<u>MECHANICAL PROPERTIES</u>	<u>ELECTRICAL PROPERTIES</u>	<u>THERMAL PROPERTIES</u>	<u>CHEMICAL PROPERTIES</u>	<u>MISCELLANEOUS PROPERTIES</u>
Tensile, compressive, shearing, and bending strengths	Electric strength	Thermal conductivity	Resistance to reagents	Specific gravity
Elastic moduli	Surface breakdown strength	Thermal expansion	Effect upon adjacent materials	Refractive index
Hardness	Liability to track	Primary creep	Electro-chemical stability	Transparency
Impact and tearing strengths	Volume and surface resistivities	Plastic flow	Stability against aging and oxidation	Color
Viscosity	Permittivity	Thermal decomposition, Spark, arc, and flame resistances	Solubility	Porosity
Extensibility	Loss tangent	Temperature coefficients of other properties	Solvent crazing	Permeability to gases and vapors
Flexibility	Insulation resistance	Melting point		Moisture Adsorption
Machinability	Frequency coefficients of other properties	Pour point		Surface adsorption of water
Fatigue		Vapor pressure		Resistance to fungus
Resistance to abrasion				Resistance to aging by light
Stress crazing				

Dielectric strength, dielectric constant and the dissipation factor are the most readily measured electrical properties. Dielectric strengths and dielectric constants are well documented for high voltage materials. Less data is available on the dissipation factor, also called loss tangent ($\tan \delta$), which is defined as:

$$\tan \delta = \frac{\sigma}{\omega \epsilon} = \frac{1}{Q} \quad (3.5)$$

where σ is the ac conductivity, and ω is the frequency in radians/s and

$$Q = 2\pi \frac{\text{average energy stored per half cycle}}{\text{energy dissipated per half cycle}} \quad (3.6)$$

Dissipation factor and dielectric constant both vary with frequency and temperature, a characteristic that should not be overlooked.

For a lossy dielectric, its admittance, Y , may be written

$$Y = G + jB \quad (3.7)$$

and for vacuum as a dielectric,

$$Y_0 = G_0 + jB_0$$

but $G_0 = 0$ in a vacuum, then

$$Y/Y_0 = B/B_0 = jG/B_0 = k^* = k' - jk'' \quad (3.9)$$

This ratio k^* is called the complex dielectric constant or permittivity.

The quantity

$$B/B_0 = \omega C / \omega C_0 = \epsilon / \epsilon_0 = k' \quad (3.10)$$

and

$$G/G_0 = C / \omega C_0 = \sigma / \epsilon_0 = k'' \quad (3.11)$$

where C = capacitance.

A dielectric may have four abrupt changes in dielectric constant, the lowest value being at highest frequency and the highest value being at very low frequency, sometimes close to dc (Figure 14). Changes in the real part of the dielectric constant, k' , are associated with significant change in the imaginary part of the dielectric constant, $-jk''$ or loss tangent.

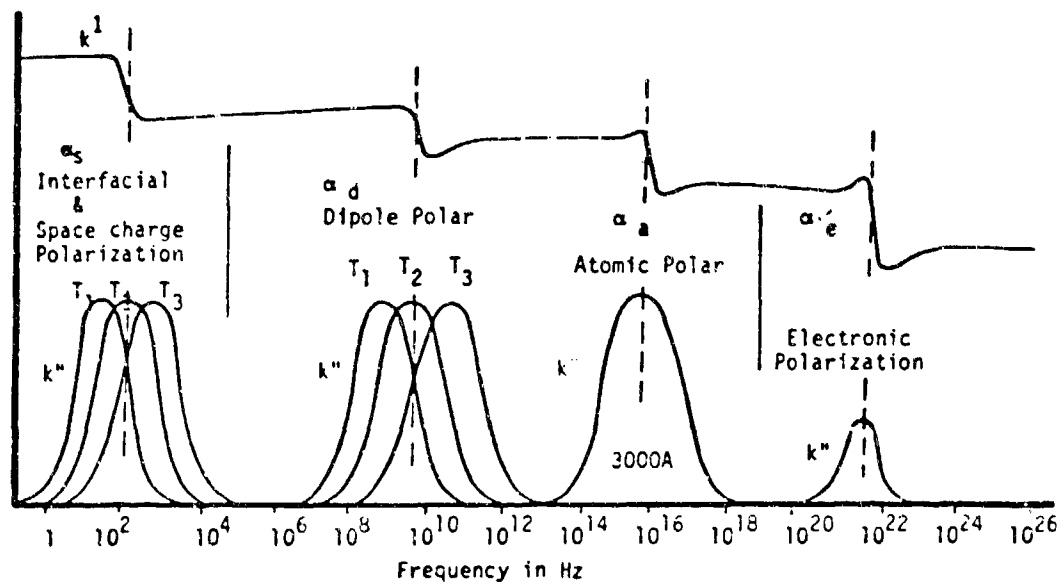

FIGURE 14. DIELECTRIC POLARIZATIONS

The sharp decreases in dielectric constant of course occur when the relaxation time of the particular polarization involved becomes equal or less than the periodicity of the applied field. That is when $\tau \leq \frac{1}{f}$. Under such circumstance the polarization has time to get well under way and contribute to the polarizability. Conversely, when $\tau \gg \frac{1}{f}$, the field reversals are too rapid and a polarization with that time constant mechanism cannot contribute to polarizability or, what is the same thing, to the observed dielectric constant. In general, α_s is effective up to several thousand cycles per second; α_d can be effective from 10^4 up to 10^{12} Hz, and even this wide range can be increased further into the low frequency area by reducing temperatures; α_a shows up in the infra-red spectrum and α_e in the optical region and above.

A high loss tangent means the dielectric will heat when voltage is applied, so the thermal conductivity of the material must be determined and a heat-balance calculation must be made to predict insulation hot-spot temperatures. Hot spots are where the insulation life will first be exhausted.

Frequency determining electronic circuits, if operated near the frequency singularities, can be affected by fluctuating interelectrode capacitance changes. Good reference material about this phenomena can be found in References 26 and 27.

3.2.2 Materials Data Pamphlets. When selecting an insulating material for a high voltage application, the right data seems to be hard to find. Mechanical and chemical data are usually abundant but too often the available electrical data is a simple tabulation of constants, with no hint of how these constants will vary. Most published data needs to be adjusted or translated into the application at hand.

The electrical properties of polyimide film (Kapton) are shown in Table 5. These variations in dielectric strength, dielectric constant, dissipation factor, volume resistivity, surface resistivity, and corona susceptibility are described below for Kapton H, a DuPont polyimide which is often used as a high-voltage insulation in aircraft. Throughout this paragraph English units of measurement are used to preserve consistency with the manufacturer's published data sheets.

Dielectric Strength. Typical values for the dielectric strength of Kapton H range from 7000 V/mil for a 1-mil film to 3600 V/mil for a 5-mil film, at 60 Hz, between 1/2-inch diameter electrodes in 23°C air at one atmosphere pressure for one minute. These dielectric strengths are based on the statistical average breakdown of carefully manufactured polyimide films having the indicated thickness. These values cannot be used in equipment design because:

- . Films vary in thickness within manufacturing tolerances.
- . The composition of Kapton-H varies.
- . The operating temperature will not be 23°C

- 26) A.R. Von Hippel, Dielectric Materials and Applications, John Wiley and Sons, Inc., New York, New York, 1954.
- 27) E.W. Greenfield, Introduction to Dielectric Theory and Measurements, Washington State University, Pullman, Washington, 1972.

TABLE 5
TYPICAL ELECTRICAL PROPERTIES OF POLYIMIDE FILM AT
23°C AND 50% RELATIVE HUMIDITY

<u>PROPERTY</u>	<u>TYPICAL VALUE</u>	<u>TEST CONDITION</u>	<u>TEST METHOD</u>
Dielectric Strength			
1 mil	7,000 v/mil	60 cycles	ASTM
2 mil	5,400 v/mil	¼" electrodes	D-149-61
3 mil	4,600 v/mil		
5 mil	3,600 v/mil		
Dielectric Constant			
1 mil	3.5	1 kilocycle	ASTM
2 mil	3.6		D-150-59T
3 mil	3.7		
5 mil	3.7		
Dissipation Factor			
1 mil	.0025	1 kilocycle	ASTM
2 mil	.0025		D-150-59T
3 mil	.0025		
5 mil	.0027		
Volume Resistivity			
1 mil	1×10^{18} ohm-cm	125 volts	ASTM
2 mil	8×10^{17} ohm-cm		D-257-61
3 mil	5×10^{17} ohm-cm		
5 mil	1×10^{17} ohm-cm		
Corona Threshold Voltage			
1 mil	465 volts	60 cycles	ASTM
2 mil	550 volts	¼" electrodes	1868-61T
3 mil	630 volts		
5 mil	800 volts		
5 mil H/2 mil FEP/ 5 mil H/½ mil varnish	1,600 volts		

- . Voltage transients must be considered.
- . Field stress with other electrode shapes is different.
- . The end-of-life dielectric strength is lower.

A more complete definition of the dielectric strength of Kapton-H is provided in Figures 15, 16, and 17. The effect of temperature on dielectric strength is shown in Figure 15. In aircraft applications, the highest operating temperature for a unit is usually specified, for example

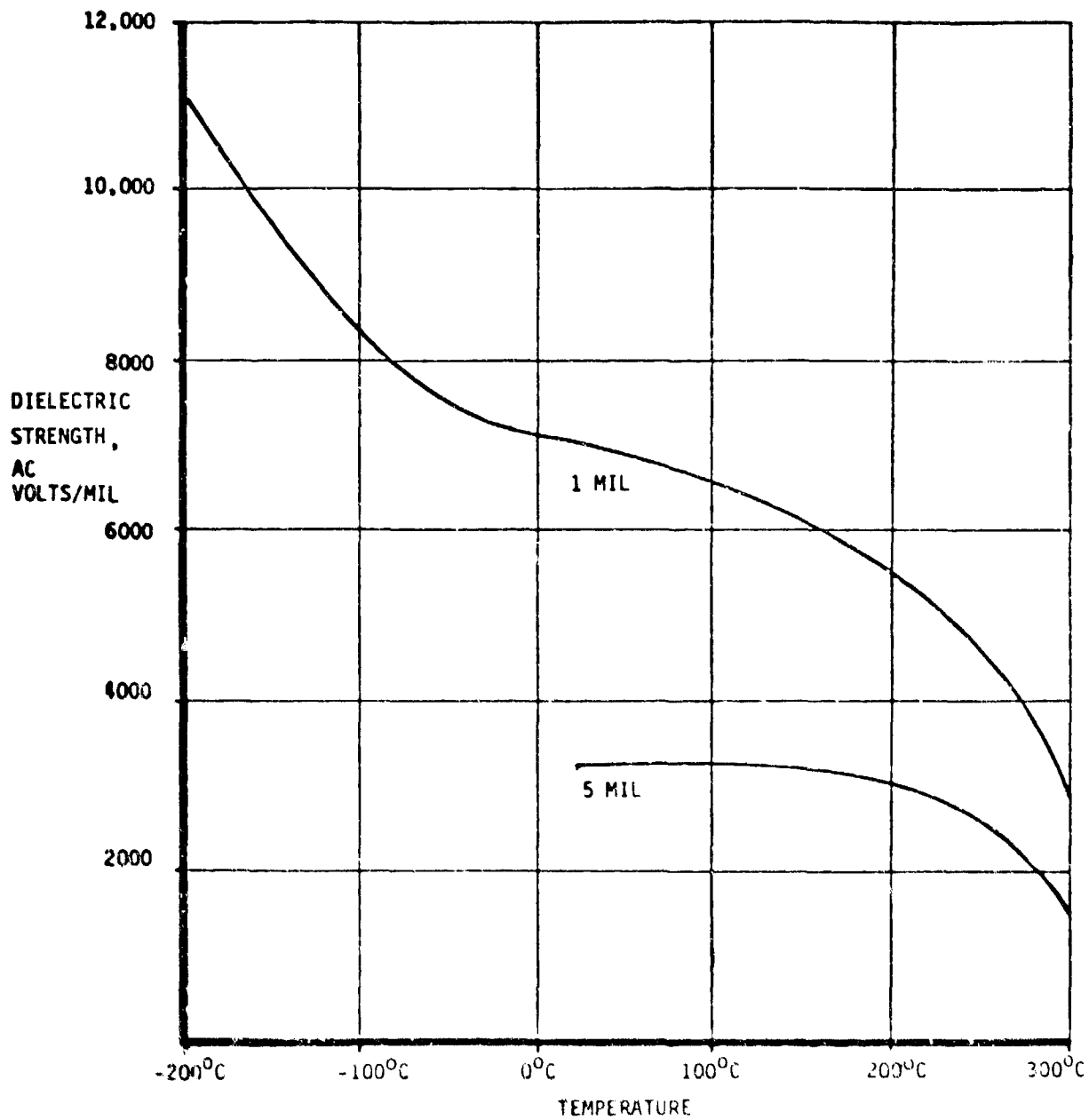

FIGURE 15. TEMPERATURE AFFECTS AC DIELECTRIC STRENGTH TYPE H KAPTON FILM

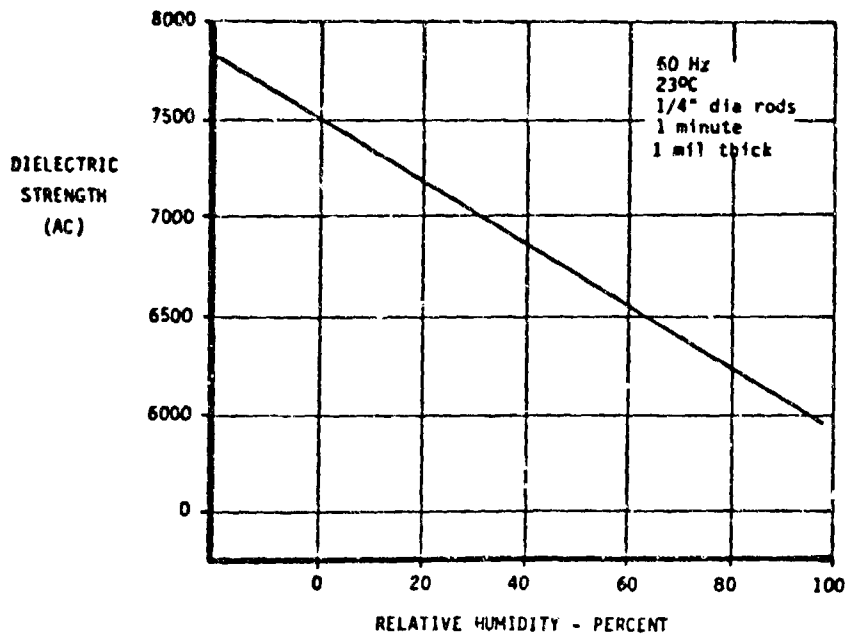

FIGURE 16. HIGH HUMIDITY DEGRADES THE DIELECTRIC STRENGTH OF TYPE H KAPTON FILM

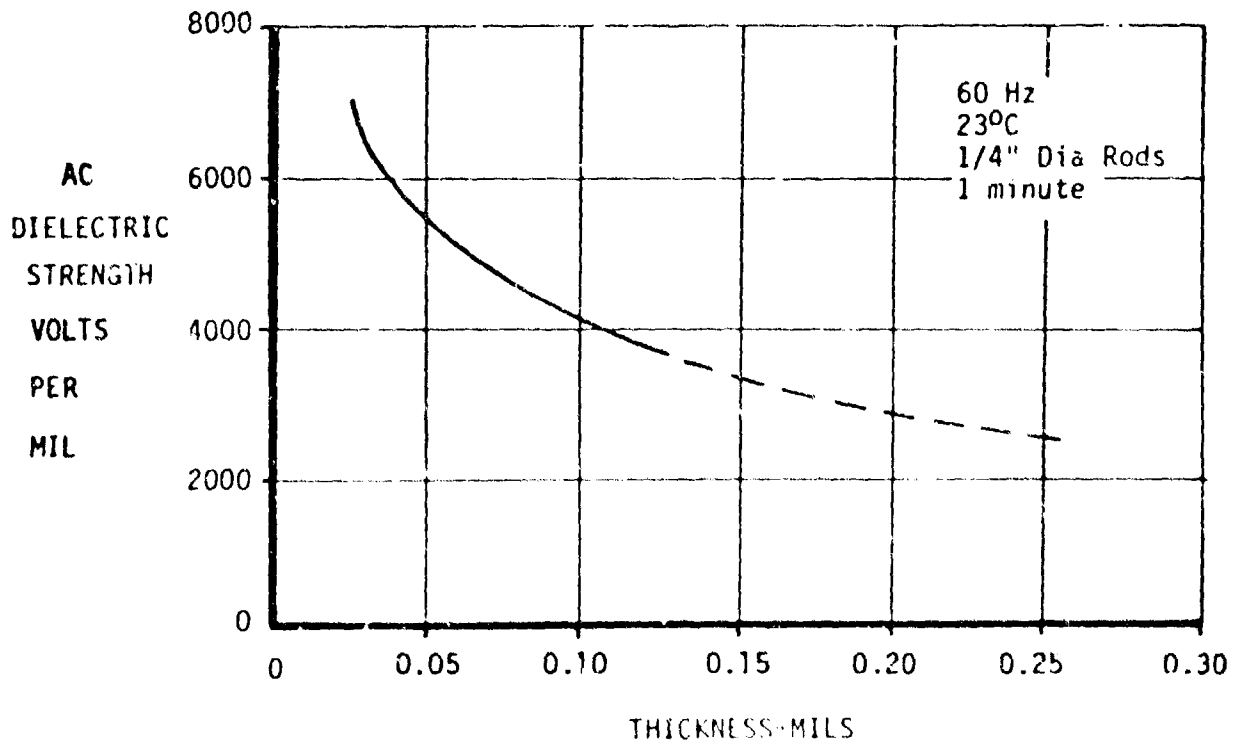

FIGURE 17. INSULATION THICKNESS AFFECTS DIELECTRIC STRENGTH OF TYPE H KAPTON FILM

as 80°C. This is not the insulation design value! The insulation design temperature must be that of the hottest point within the equipment. An electrically insulated heat-generating element will operate at a temperature which is sufficiently hotter than ambient to drive the generated heat through the insulation. For instance, the hot spot within the slot insulation of an electrical machine may be 20°C higher than the nominal temperature in the machine. Such "hot spots" are created by high current densities in wiring and heat generating mechanisms in the insulation itself. It is obvious from Figure 15 that an extra 20°C may lower the dielectric strength considerably when the insulation is either thin or operated at temperatures above 200°C.

Relative humidity also affects the dielectric strength of Type-H Kapton as shown in Figure 16. For this reason, very high-voltage equipment is often packaged in sealed containers back-filled with a dry dielectric gas such as sulfur hexafluoride. Generally, insulation in dry gas has higher dielectric strength than in moist gas. Dielectric strength tests are usually made at near 50% relative humidity.

Many insulations outgas into the surrounding media with time and heat. Often one of the outgassing products is water, which will raise the relative humidity of the gas and may even contribute to the formation of acids in the enclosure.

Most insulation test samples are either 1 mil or 5 mils thick. In high voltage work, thin insulation doesn't have enough dielectric strength so composite insulations having several layers of thin insulation are required. The dielectric strength of insulation decreases with thickness, as shown in Figure 17.

Total area of insulation is a factor often neglected in literature and data sheets. For areas of a few square centimeters, the effect is small, usually requiring less than 5% derating. For large areas, the required derating is considerable, as shown in Figure 18. This loss of dielectric strength is caused by roughness of electrode surfaces and non-uniform thickness of the manufactured insulation.

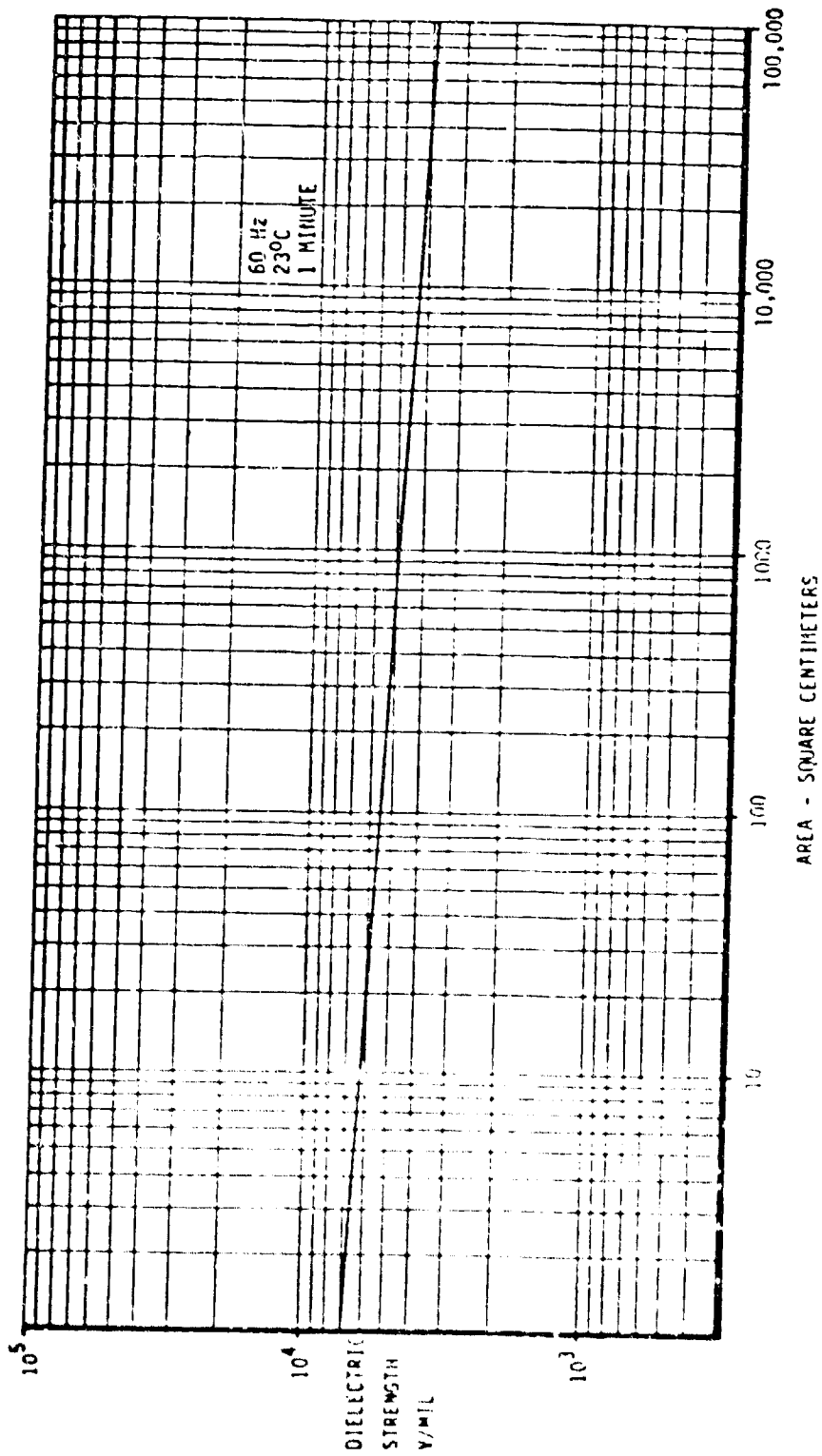

FIGURE 18. FILM AREA VS DIELECTRIC STRENGTH OF TYPE H KAPTON

Insulation Life. Finally, the most important factor in high voltage insulation design is the life of the material. Each year many technical papers are published on the measurement of life factors, the deviations associated with the test data, and the preconditioning of test samples. All these significant factors must be considered. However, the designer often has difficulty in finding data other than from one minute tests at 23°C and 60 Hz between 1/2 inch diameter electrodes. Such tests tell little about the long-life characteristic of the material. The life of Type-H Kapton Polyimide is shown in Figure 19 for film exposed and not exposed to partial discharges. With the exposed samples, partial discharges were present whenever the initiation voltage of 465 volts was exceeded.

The characteristic life of a material can be evaluated as a function of temperature when available data are plotted as an Arrhenius plot with long life on the abscissa and the reciprocal of the absolute temperature on the ordinate (Figure 20). Life as a function of temperature is determined by measuring the breakdown at 50 percent of the one-minute level. Data for the life-temperature plot is taken as follows: 1) numerous samples are kept at constant test temperatures, 2) periodically a few samples are withdrawn and their breakdown voltages are measured, 3) when the statistically developed breakdown voltage of the withdrawn samples is 50 percent of the initial one-minute breakdown voltage, the end-of-life is assumed to be reached for the specific sample and its temperature. The life test must be conducted at several temperatures; therefore, much testing is required to gain this important information.

Dielectric strength has been shown to vary with temperature, time, thickness, area, and humidity. An example will illustrate how these variations affect design. Consider a one-mil-thick Kapton insulation between parallel plates operating at a voltage below that at which corona starts. This insulation is 100 square inches in area, its "hot spot" temperature is 160°C, relative humidity is zero, anticipated life is 1000 hours, and the frequency is 400 Hz. The maximum allowable applied voltage across the insulation can be calculated as follows:

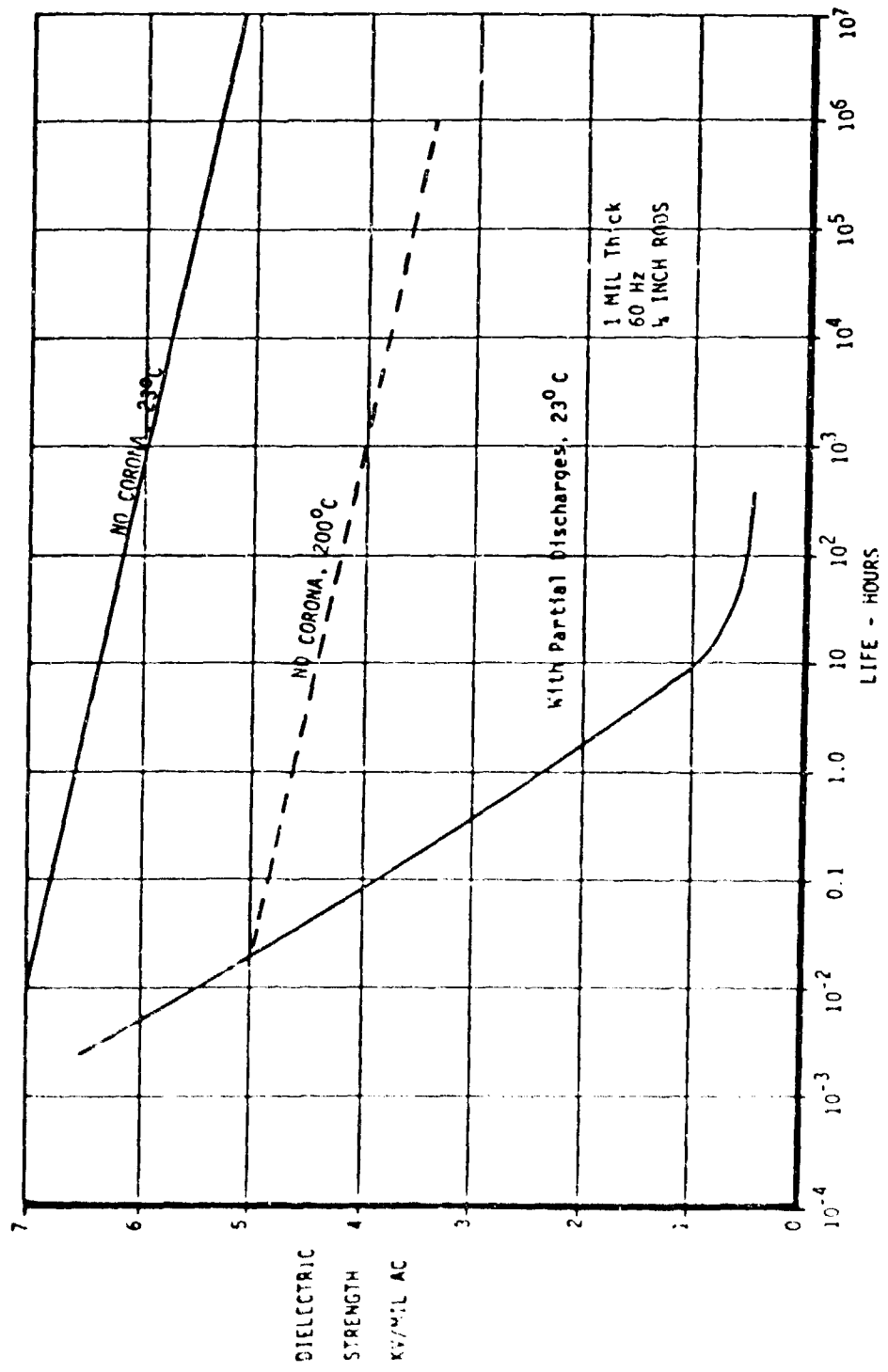

FIGURE 19. LIFE AS A FUNCTION OF VOLTAGE FOR TYPE H KAPTON FILM

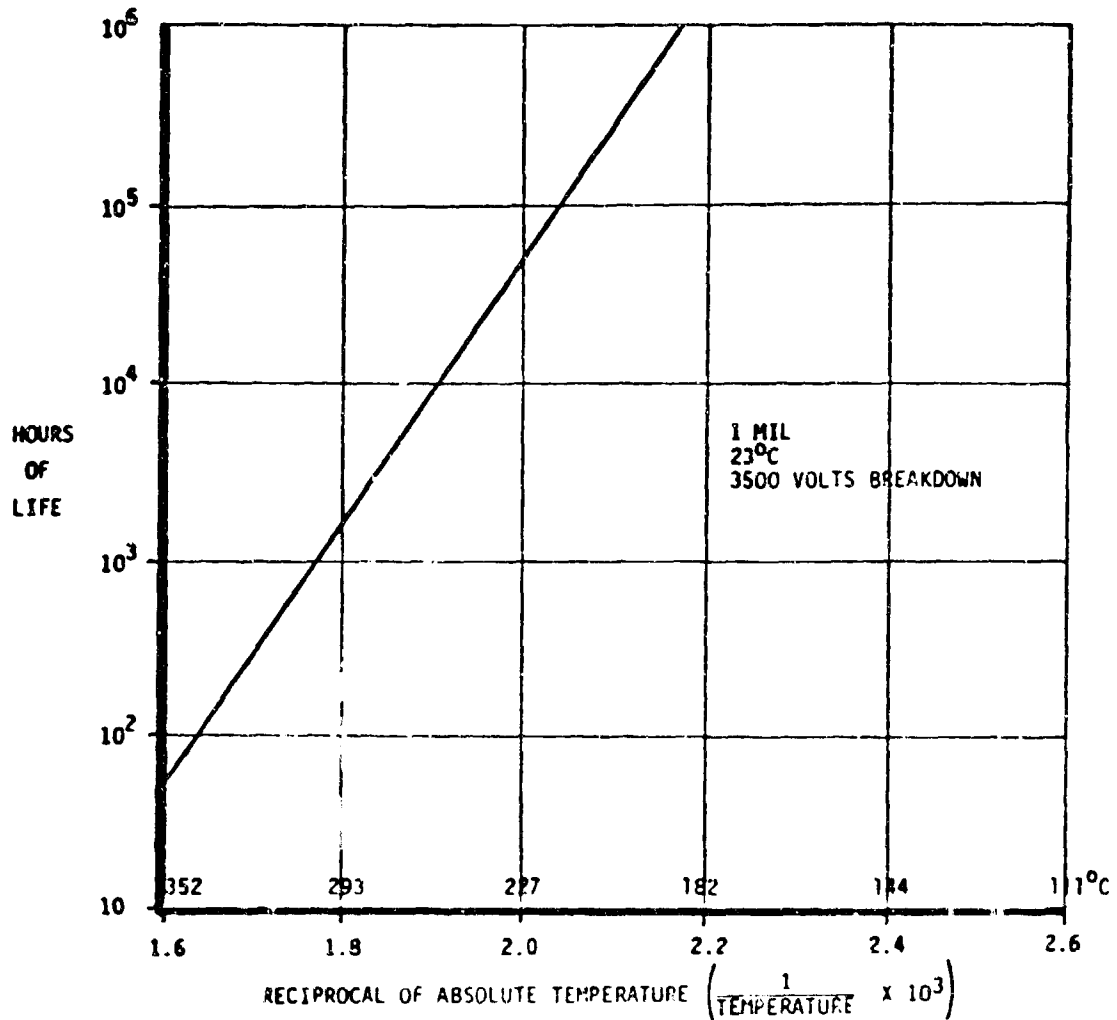

FIGURE 20. HEAT REDUCES THE TIME FOR KAPTON TYPE H FILM TO FALL TO HALF OF ORIGINAL DIELECTRIC STRENGTH

Factor	Effect
(ΔT) Thickness (1 mil)	1.0 thickness variation
(ΔH) Relative humidity (operant)	1.071 initial
(ΔA) Area (100 sq. inches)	0.714
(ΔF) Frequency 400/60	6.67 times 60 Hz life
Life: (400/60 x 1000 6670 equivalent 60 Hz hours at 200°C)	3830 volts (Figure 18)

<u>Factor</u>	<u>Effect</u>
(AI) Impurities (inclusions)	0.66 (particulate)
(AM) Manufacturing and handling	0.925
(AL) 2 σ life	0.66
Voltage - Product of:	Life times factors
	3830 x 0.274 = 1050 volts for a
	1 mil thickness.

One factor not included in the above is the degradation during application of the insulation to the electrodes. Application effects include damage to the insulation by mechanical bending, twisting, cleansing, and placing it on or between the electrodes. The value of the application factor should be lower for dielectrics that must be forced into final position, such as winding insulation that is forced into tight slots.

Dielectric Constant and Dissipation Factor. The effects of frequency on the value of the dielectric constant and dissipation factor at several temperatures are shown in Figures 21 and 22. There are frequency ranges at which the dissipation factor is high and the dielectric constant varies. Sometimes the dielectric must be operated in a regime where the dielectric constant and dissipation factor are constant to avoid dielectric heating and interelectrode capacitance changes. In such designs the operating temperature must be known because the dissipation factor and dielectric constant change with temperature.

Most measurements of dissipation factor are made at 1000 Hz and 23^oC, whereas the insulation will be operated at 400 Hz to 20 kHz, and at 80^o to 200^oC. This leaves for the designer the problem of measuring the dissipation factor, searching for meaningful data, or extrapolating what data he has.

Resistivity. A high volume resistivity reduces heating of the dielectric. Values greater than 10¹² ohm-cm are adequate for most power equipment. High-voltage insulations should have a volume resistivity greater than 10¹⁴ ohm-cm. Polyimides in high-voltage service should be operated at temperatures lower than 200^oC, as suggested in Figure 23.

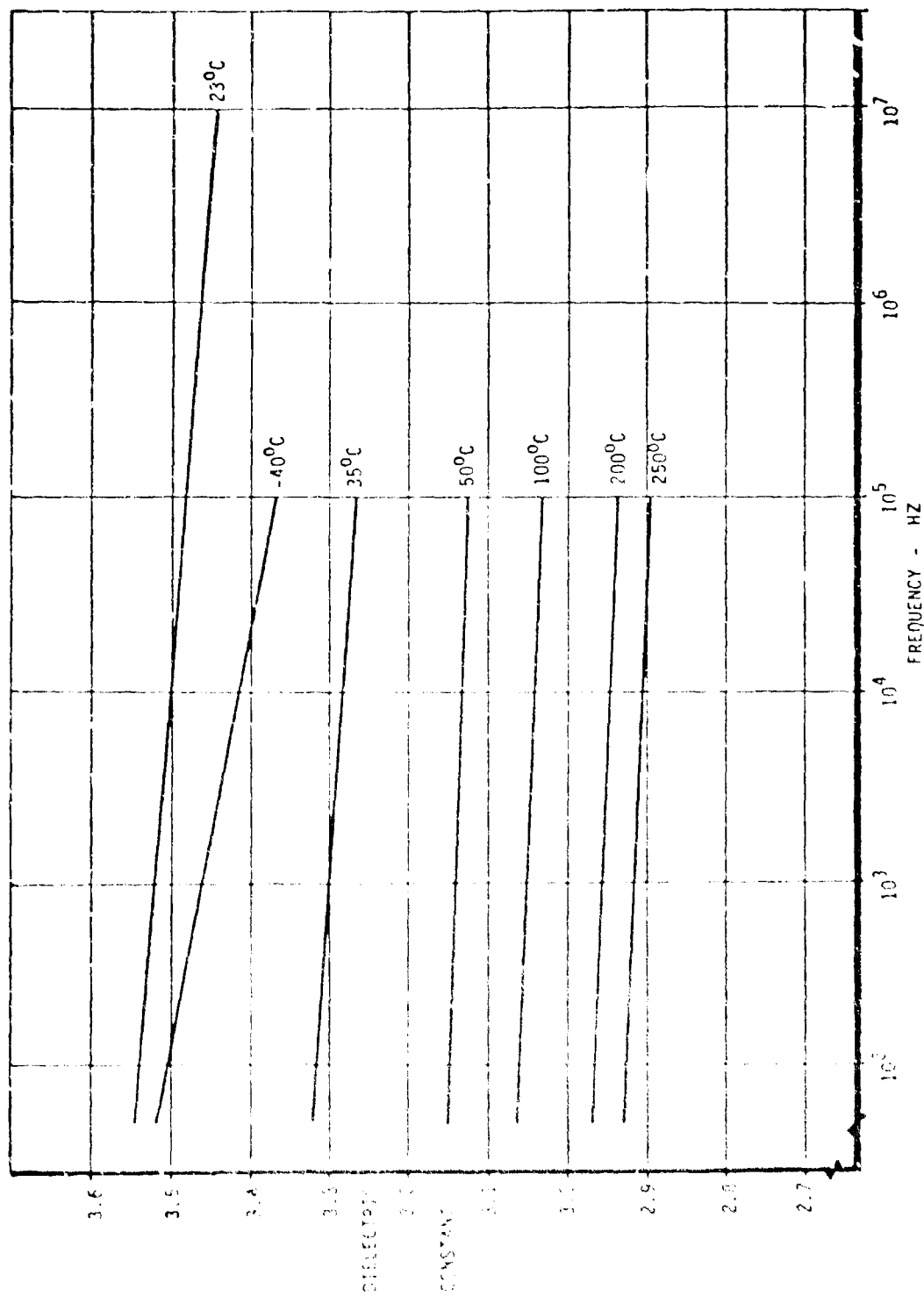

FIGURE 21. DIELECTRIC CONSTANT VS FREQUENCY FOR 1 MIL THICK TYPE H KAPTON FILM

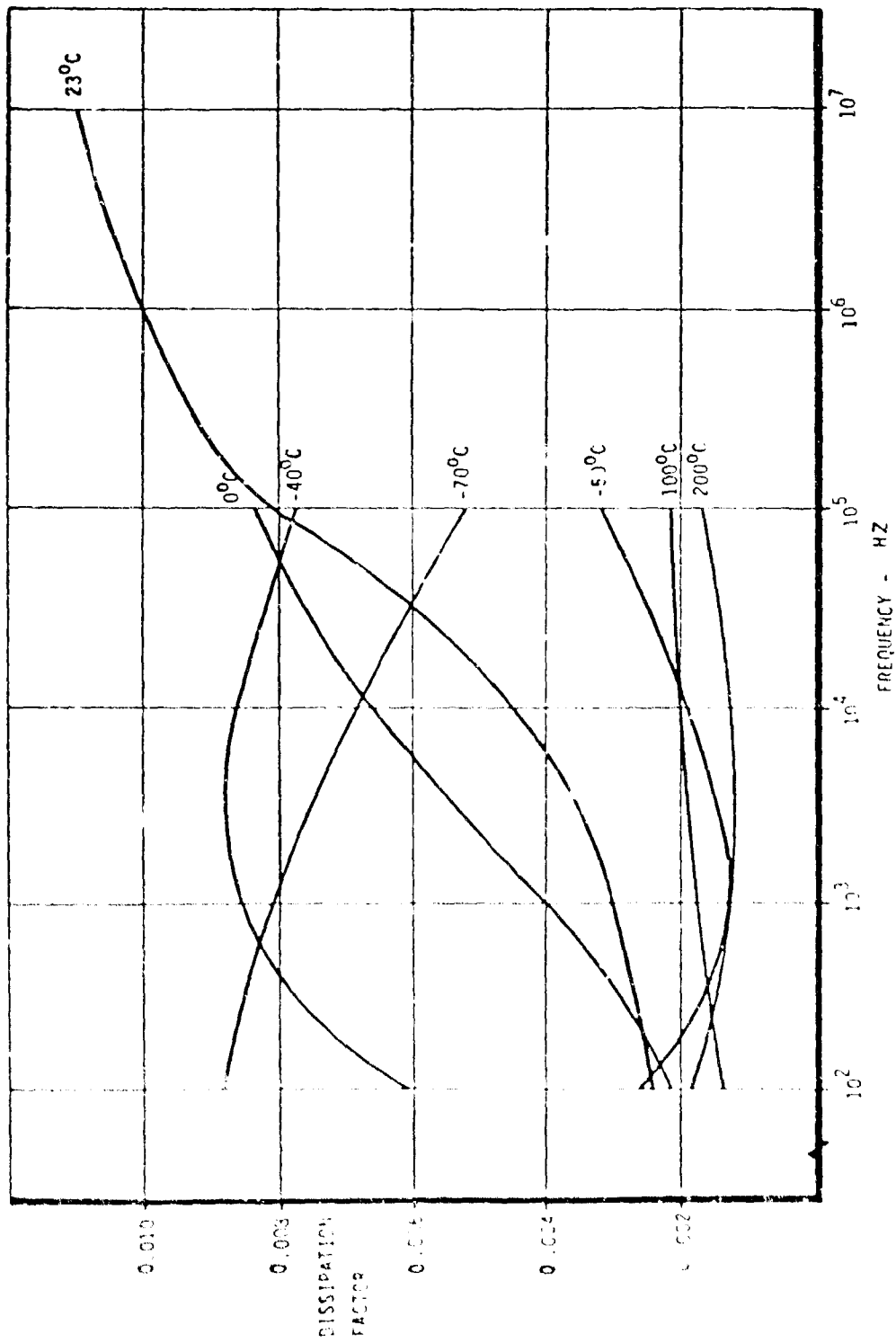

FIGURE 22. DISSIPATION FACTOR VS FREQUENCY FOR 1 MIL THICK TYPE H KAPTON FILM

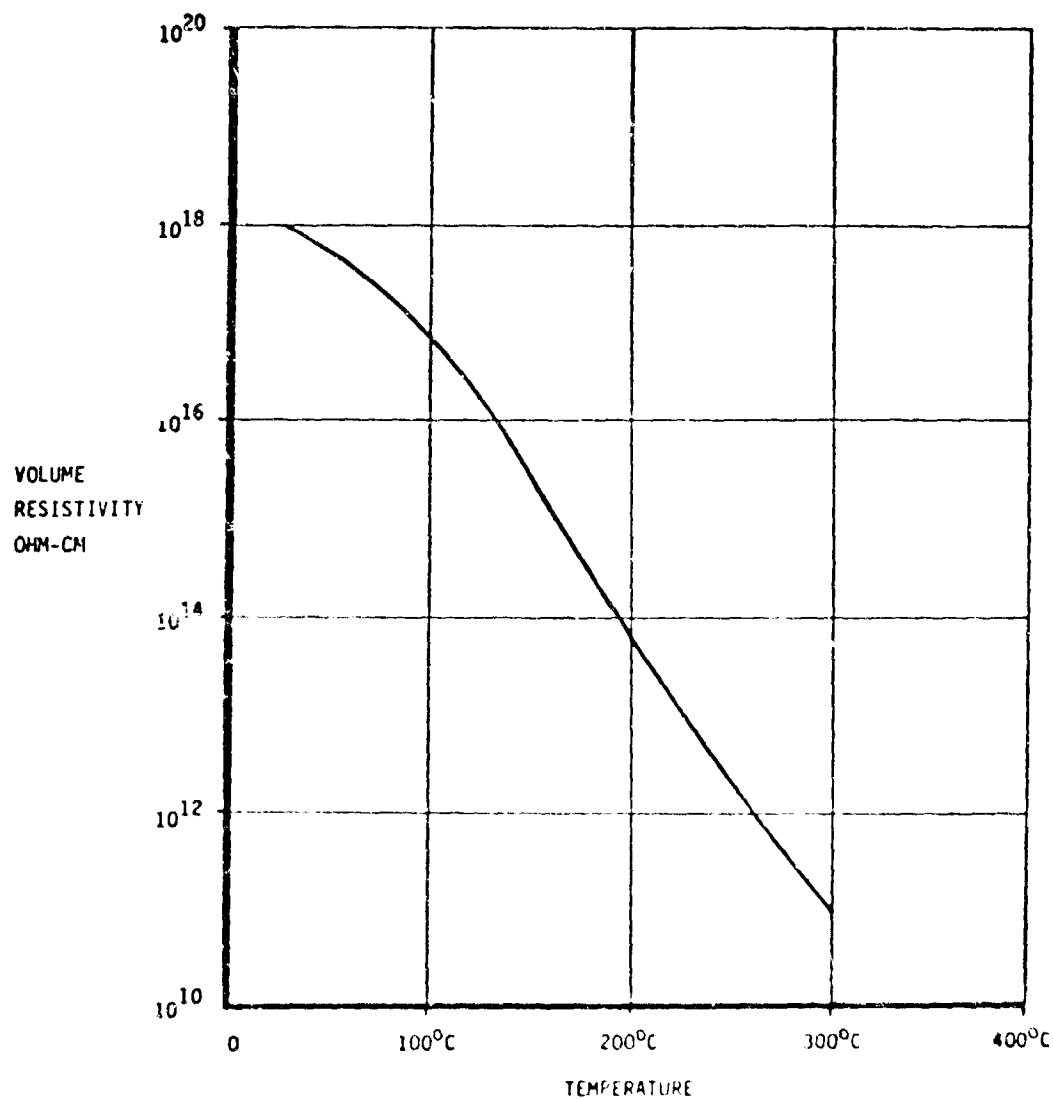

FIGURE 23 VOLUME RESISTIVITY OF TYPE H KAPTON FILM AT 1 KHZ DECREASES AS TEMPERATURE IS RAISED

Surface resistivity must be greater than 10^9 ohm-cm or tracking and eventual flashover will take place. New insulation usually has a surface resistivity greater than 10^{12} ohm-cm at 23°C and 50 percent relative humidity. This value is much less with higher humidity and temperature. If the surface resistivity is reduced to 10^8 to 10^9 ohm-cm by contamination,

a significant surface leakage current will flow. This will dry out the surface and form a dry band. The dry band will be bridged by a small electrical discharge, since the stress locally will exceed the breakdown stress of air at the air-solid interface. The heat from the discharge will decompose the insulation and form a conducting path on the surface. With time, the paths will propagate, forming a tree, and breakdown eventually follows.²⁸

3.3 Basic Theory of Partial Discharges in Cracks and Voids. A microscopic theoretical description of partial discharges is straight-forward and can be readily related to observed phenomenon. Expanding this description to the microscopic regime becomes very complicated because voids and cracks vary in shape, smoothness, and composition, and each partial discharge produces chemical products that change the gas composition within the void and also the surface of the crack or void. As a consequence, a set of theoretical models that can usefully predict the effects of partial discharges must be based largely on the manipulation of empirical data derived from tests using circuits such as shown in Figure 24.

3.3.1 Size, Shape, Location, and Distribution of Voids and Cracks. A precise count of the number of cracks and voids is very hard to get, requiring sectioning the sample dielectric and scanning it with a mass spectrograph or similar instrument. Even then, many cracks and voids would be unaccounted for or lost during the dissection process. It is easier to derive the size, shape, and general location of cracks and voids within the part or dielectric medium from non-destructive optical and electrical observations.

Cracks and voids are easily located in transparent and some slightly opaque materials with polarized light and a magnifying glass. Polarized light shining through the dielectric illuminates the cracks and voids, which then appear as skinny lines, curved surfaces, and bulges in the insulation. Slowly rotating the polarizing screen brings out other portions

28) M.A. Billings, A. Smith, and R. Wilkins, "Tracking in Polymeric Insulation," Trans. on Elec. Insulation, III, Vol. EI-2, No. 3, December 1967, pp. 131-137.

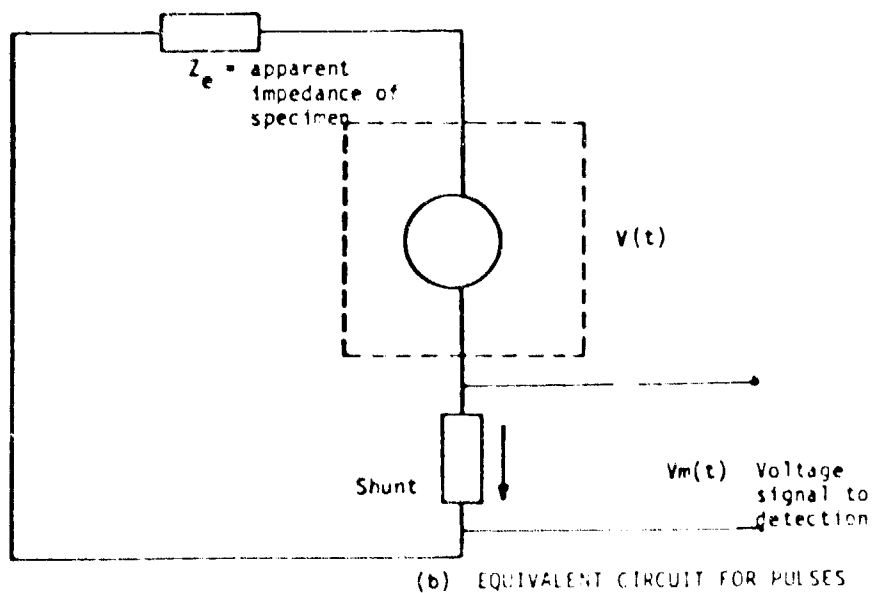
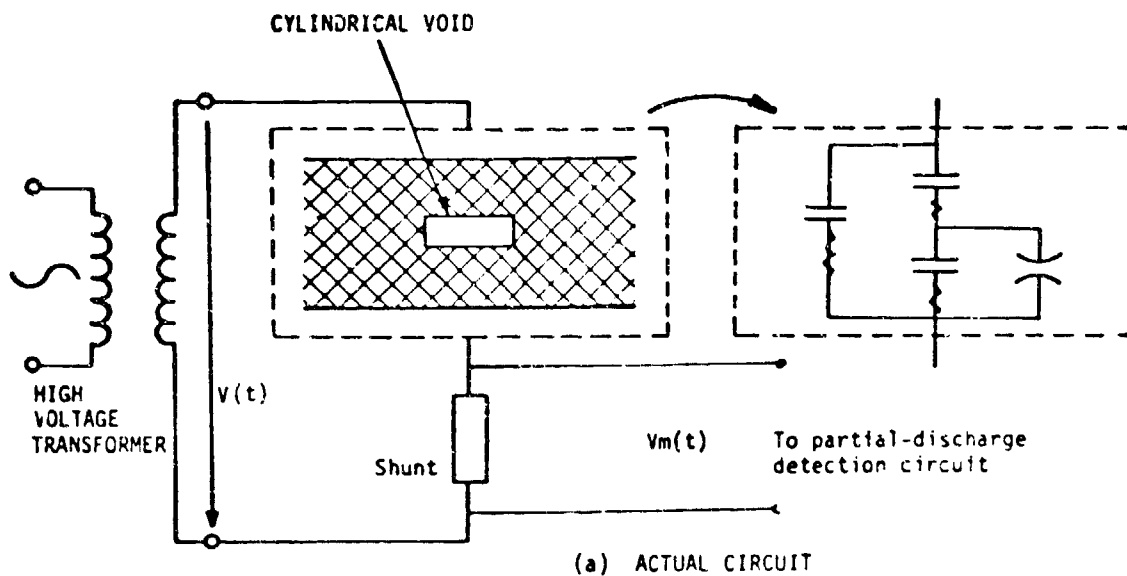

FIGURE 24. TEST CIRCUIT FOR MEASUREMENT OF PARTIAL DISCHARGES

of the cracks and voids. This is a low-cost, effective, and fool-proof method of detection, provided the dielectric is transparent. Only surface cracks and voids can be seen in black and opaque materials, but even these are important to find prior to expensive electrical testing. Interior cracks and voids become evident during electrical testing.

A void in a dielectric is an island having a dielectric constant that differs from that of the dielectric, thus altering the electric field in its vicinity. Shown in Figure 25 are examples of dielectric stress augmentation in voids.²⁹ The following symbols appear in the illustration:

- E_0 = Voltage stress in the gas (disc)
- E_c = Voltage stress in the dielectric in series with the gas filled void
- ϵ_r = Dielectric constant of the material
- E_{om} = Voltage stress in the gas (sphere)
- E_{av} = Voltage stress across the solid dielectric
- V = Voltage across the void

The worst case is that of the disc shaped void shown in cross section on the left side of the figure. Here, with a width much greater than d , virtually all of the electric flux intercepted by the area of the disc ($E_0 \times E_{av} \times \text{area}$) is forced to pass through the void. The stress in the gas dielectric necessary to sustain this flux is seen to be $E_0 = k E_{av}$ where k is the dielectric constant of the dielectric material.

A spherical void is shown in cross section on the right side of Figure 25. Here, part of the average flux in the solid insulation skirts the void while the remainder passes through the void. The effect, however, is such that the maximum stress, E_{om} , always exceeds the average stress, E_{av} , as given by the formula in the figure. A value for polyethylene is shown. If the dielectric constant of the material is increased, the field augmentation will increase proportionally for the disc type void, but for the

29) P.F. Brins, *Plastics for Electrical Insulation*, Interscience Publishers, R.Y., N.Y., 1966, pp. 45-58.

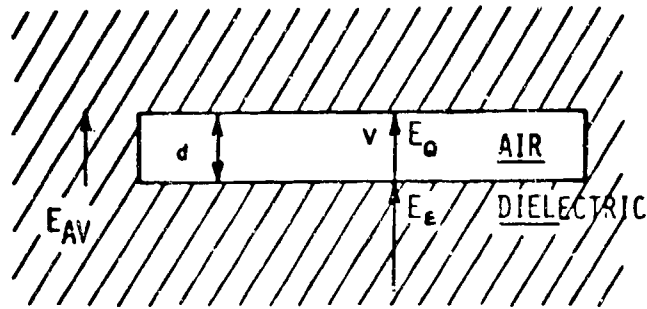

$$E_0 = \epsilon_r E_\epsilon = 2.25 E_\epsilon$$

$$E_0 > 70 \text{ v/MIL} \quad v > 300$$

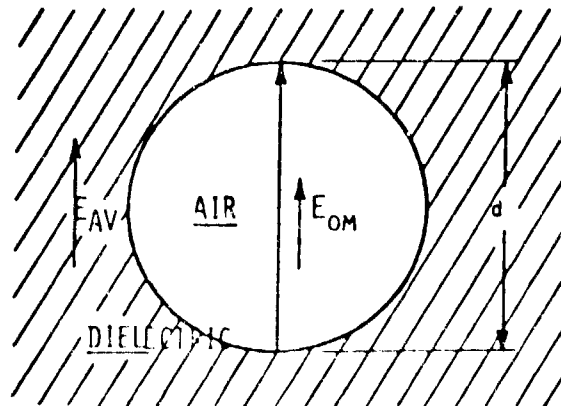

$$E_{OM} = \frac{3\epsilon}{1 + 2\epsilon} E_{AV}$$

$$= 1.23 E_{AV} \text{ (POLYETHYLENE)}$$

FIGURE 25. STRESS INCREASE IN VOIDS

spherical void it is seen to approach a maximum value of $1.5 E_{av}$. A low dielectric constant insulation will minimize the effect of voids.

The effect of void size will now be considered. The capacitance of a small disc shaped void is

$$C_0 = \frac{\epsilon_0 A}{d}$$

Where k is the dielectric constant of the enclosed media (gas = 1.0), A is the area of the disc in square meters, d is the separation between the faces of the disc in meters, and ϵ_0 is the permittivity of evacuated space, 8.885×10^{-12} farad per meter. The value C_c is important because it can be used in calculating the magnitude and energy of a pulse during a partial discharge in the void.

What happens when C_c discharges was analyzed by J.H. Mason³⁰. The small capacitor C_c in the circuit shown in the sketch is instantaneously short-circuited. The consequent charge transfer is:

$$Q_c = \left(C_c + \frac{C_a C_b}{C_a + C_b} \right) \Delta V_c = \Delta V_c \left(\frac{C_a C_c + C_b C_c + C_a C_b}{C_a + C_b} \right) \quad (3-12)$$

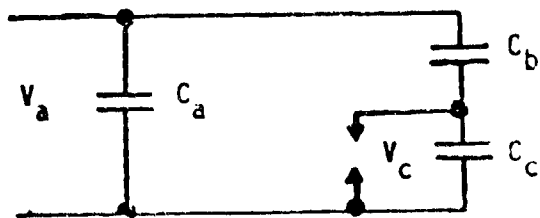

Where:

- V_a = applied voltage
- V_c = voltage across the void
- C_a = capacitance of the total dielectric less that of the void and C_b
- C_b = capacitance of dielectric in series with the void
- C_c = capacitance of the void
- Q_a = apparent discharge magnitude detected at the terminals
- Q_c = discharge magnitude in the void

Simultaneously, a voltage pulse, which is effectively a step voltage (δV_a) having a risetime of between 10 and 100 nsec, is generated at the terminals of the insulation:

30) J. H. Mason, "Discharge Detection and Measurements," Proceedings of IEEE, Vol. 112, No. 7, July 1965, p 1407.

$$V_a = \Delta V_c \left(\frac{C_b}{C_a + C_b} \right) \quad (3-13)$$

The apparent discharge magnitude, observed at the terminals, is:

$$Q_a = \Delta V_a \left(C_a + \frac{C_b C_c}{C_b + C_c} \right) = \Delta V_a \left(\frac{C_a C_b + C_a C_c + C_b C_c}{C_b + C_c} \right) \quad (3-14)$$

We can simplify the handling of the expression by letting: (3-15)

$$C_3 = C_a C_b + C_a C_c + C_b C_c$$

Usually, a small area of the discharge site is almost completely discharged, so that:

$$\Delta V_c \approx V_c = V_i \left(\frac{C_b}{C_b + C_c} \right) \quad (3-16)$$

$$\frac{Q_c}{Q_a} = \left(\frac{\Delta V_c}{\Delta V_a} \right) \left(\frac{C_3}{C_a + C_b} \right) \left(\frac{C_b + C_c}{C_3} \right) \left(\frac{\Delta V_a}{\Delta V_c} \right) \left(\frac{C_a + C_b}{C_b} \right) \quad (3-17)$$

$$= 1 + \frac{C_c}{C_b} \quad (3-18)$$

Most of the charge is released from the region where $\Delta V_c \rightarrow V_c$, so the energy liberated will be:

$$W = 1/2 Q_c V_c = 1/2 Q_a \left(1 + \frac{C_c}{C_b} \right) V_i \left(\frac{1}{1 + \frac{C_c}{C_b}} \right) = 1/2 Q_a V_i \quad (3-19)$$

where:

- W = energy in nanojoules
- V_i = applied voltage in kilovolts peak
- Q_a = charge in picocoulombs

Thus, we have a method of calculating the voltage, charge, and energy of a partial discharge in a void for a given applied voltage from the dimensions of the void and the dielectric constant of the surrounding dielectric.

A method of handling the distribution of voids was recently developed by S. Herabayashi, Y. Shebuya, T. Hasegawa, and T. Inuishi.³¹ First they analyzed a single void for initiating voltage V_s and charge Q caused by partial discharges. Then the "void distribution function" $M(d,s)$ was defined, with s the discharge area and d the gap spacing, assuming that many voids exist within the insulation whose gap spacings and discharge areas are $d \sim d+dt$ and $s \sim s+ds$ respectively. The total number of voids (N_t) can then be described by the expression:

$$N_t = \int_0^\infty \int_0^\infty M^*(V_s, Q) dV_s dQ$$

Where M^* = is another void distribution function.

The number of partial discharges whose charge is $(Q_j - \Delta Q/2) < Q < (Q_j + \Delta Q/2)$ during a half cycle at ac voltage will be determined for each half cycle using a pulse height analyzer or similar recording device, giving the value N_{ij} which corresponds to $N(V_i, Q_j)$. This expression can be then reformed to a reference equation as follows:

$$M^*(V_i, Q_j) = \frac{N_{i+1}^j - N_i^j}{V_{i+1} - V_{i-1}} - \frac{2}{V_i} N_{ij} \quad (3-21)$$

$$+ \frac{2}{V_i^2} \sum_{k=1}^j N_{kj} \left(\frac{V_{k+1} - V_{k-1}}{2} \right)$$

With this analysis tool, several types of partial discharges and other phenomena can be distinguished in test data. These phenomena include loose contacts (pulse at 0 voltage level) creepage paths (pulses with high magnitude at peak voltage and zero magnitude at zero voltage), small voids (single spikes), and partial discharges which have multiple spikes.

3.3.2 Material Dielectric Constant and Conductivity. The previous equation.

31) S. Hirabayashi, et al., "Estimation of the Size of Voids in Coil Insulation of Rotating Machine," IEE Transactions on Electrical Insulation, Vol. EI-9, No. 4, Dec. 1974, pp 129-136.

$$Q_c = \Delta V_c \frac{C_a C_c + C_b C_c + C_a C_b}{C_a + C_b} \quad (3-22)$$

Indicates that for a given charge transfer, V_c depends upon the capacitances C_a , C_b and C_c . Since capacitance is $C = k\epsilon_0 \frac{A}{d}$, each capacitance depends upon the dielectric constant. The lowest voltage across the void will occur with short gap spacing d , and low dielectric constant. As the dielectric constant is increased the field stress across the void increases, resulting in more and bigger partial discharges.

Insulating materials have very high volume resistivity, so conductivity has negligible effect on partial discharges initiated by ac voltages, conductivity is significant when a dc voltage is applied. The dc-circuit analog of the above equation is obtained by substituting for

- C_a a fixed resistor of value R_a .
- C_b a resistance of higher value R_b .
- C_c a resistance of infinite value, or C_c .

Applying a dc voltage across very high resistivity dielectric produces these effects: (1) the initial distribution of the dc potential across the dielectric is related to the capacitance of its components, (2) in time, this distribution changes to relate to the resistivities of the components of the dielectric, (3) initial space charges within voids dissipate, allowing partial discharges to occur, breakdown voltage of the contained gas is exceeded, and (4) the discharge initiation and extinction voltages across the void depend upon the temperature, increasing to temperature decreases. For pure dc the discharge rate R is:³²

$$R = \begin{cases} 0 & E_c < E_d \\ \sigma / E_d k & E_c \geq E_d \end{cases}$$

where:

- E = voltage across the dielectric
- E_c = voltage across the void
- E_d = initiation voltage for the gas filled void
- σ = bulk conductivity of the insulation

(32) H. Feibus, "Corona in Solid Insulation Systems," IEEE Transactions on Electrical Insulation, Vol. EI-5, No. 3, September 1970, pp. 72-78.

3.3.3 Gas Pressure and Composition. Prior to flight, the voids and cracks within unpressurized electrical insulation are at near Earth sea-level ambient pressure. In flight, the ambient pressure falls, and the pressure inside the voids decreases very slowly. In the meantime, the materials surrounding the void are backfilling the void with their outgassing, which may contain hydrogen, hydrocarbons, or halogens (fluorides). Some of these gases, particularly hydrogen and some hydrocarbons, have low breakdown voltage (Figure 6).

Model voids used to evaluate insulations usually have gap thicknesses (dimension d) of 0.025 to 0.25 mm, which are representative of values found in practice.³¹ Voids as small as 0.005mm were measured in oil-filled paper capacitors. They were in unimpregnated paper and between films and electrodes. These voids caused multiple failures, so the capacitors had to be redesigned to eliminate the voids. In those same capacitors, which had been designed for terrestrial use, the voids were found to be filled with a mixture of hydrogen and hydrocarbons from the oil and paper.³³

If the size of the void is known, then the Paschen-law curve can be used in calculating the voltage at which partial discharges will initiate. For example, with hydrogen the pressure-times-spacing-factor is:

$$\begin{aligned} \text{Pressure} &= 1 \times 10^5 \text{ N/m}^2 \text{ at Earth ambient} \\ \text{Distance} &= 2.5 \times 10^{-3} \text{ cm} \\ Pxd &= 250 \text{ pa-Cm} \\ Pa &= \text{N/m}^2 \end{aligned}$$

The voltage at which discharges will initiate across the void can then be obtained from Figure 6. For example, for hydrogen, V_c would be 300 volts.

Conversely, if the applied voltage at which partial discharges occur is known, the above equations can be used to test for the presence of

33) B. Ganger, and G. Water, "On Electrical Aging of Oil-Impregnated High-Voltage Dielectrics," *IEEE Transactions on Electrical Insulation*, Vol. EI-8, No. 3, Sept. 1973, pp. 307-317.

hydrogen.

The field strength within the void or crack will decrease with time as shown by K. Kikuchi, K. Ninomiya, and H. Miyauchi.³⁴ They also found that the dc breakdown strength of cross-linked polyethylene decreased with increased pressure. A fifty percent decrease in breakdown strength was measured for a temperature increase of 45°C using thin sheets (0.1mm) without cable impregnating additives. Thicker sheets (1.0mm) with and without additives had less than 35 percent decrease in breakdown strength.

3.3.4 Surface Surrounding Void. Initially the void or crack surfaces will be reasonably smooth, macroscopically, in encapsulating materials such as epoxies and polyurethanes. Microscopically the surfaces are always rough with caves and jagged protrusions just as are the surfaces of metallic electrodes.

As the void or crack is exposed to partial discharges, the surfaces will be either eroded (silicones) or treeing will take place (epoxies). The treeing tends to go toward the point of high voltage. Both treeing and erosion will make the void bigger, increasing the number and magnitude of the discharges and eventually lead to breakdown of the dielectric.

3.3.5 Temperature Effects. Much useful information concerning molecular structure can be derived by analyzing how the anomalous dispersion is shifted with frequency and temperature. For practical insulation materials, substantial changes in dielectric properties occur at high temperature (Figures 21 and 22). At room temperatures and low frequency, dielectric loss is low and changes but slightly as temperature is increased. On further heating, the viscosity of the polymer is decreased until polar groups can move under the forces supplied by the external field. At some temperature, polarization and relaxation will be in equilibrium with the applied field at all times during a cycle. In such a

34) K. Kikuchi, et al., "Characteristics of DC Dielectric Breakdown of Plastic Insulation," *Transactions of Electrical Insulation and Dielectric Phenomena*, 1971 Annual Conference, Nat. Academy of Sci., pp. 327-331.

high temperature regime, dielectric loss increases very rapidly with temperature. The loss-temperature curve rises continuously and the polymer at high temperatures becomes a semiconductor (Figure 23).

Significant changes in the dielectric constant also occur with change in temperature (Figure 21), altering the parallel and series capacitances surrounding an enclosed void or crack. Lowering the dielectric constants lowers the impressed voltage across the void. The partial discharge initiation voltage would then rise if gas density were held constant inside the void. The density of a gas is a function of temperature and pressure. The gas density is defined as the number of molecules per cubic centimeter at pressure P . Pressure, volume, and temperature of a perfect gas are related by the equation: $PV = NRT$.

where: P = pressure in torr
 V = volume in cubic centimeters
 T = absolute temperature in degrees Kelvin
 N = number of moles
 R = Joules per degree Celcius per mole

As gas density is increased from standard temperature and pressure, the partial discharge initiation voltage is increased because at higher densities the molecules are packed closer, and a higher electric field is required to accelerate the electrons to ionizing energy within the mean free path. The partial discharge initiation voltage decreases as gas density is decreased from standard pressure and temperature because the longer mean free path permits the electrons to gain more energy prior to collision. As density is further reduced, a minimum initiation voltage is eventually reached. The pressure corresponding to minimum initiation voltage depends on the gap spacing. A representative minimum initiation voltage for air is 326 volts dc.

With a further reduction in density, the initiation voltage rises steeply because the spacing between gas molecules becomes so great that although every electron collision produces ionization, it is hard to achieve enough ionizations to sustain the chain reaction. Finally, the pressure becomes so low that the average electron travels from one

electrode to the other without colliding with a molecule. This is the reason why the minimum initiation voltage varies with spacing--as the spacing is decreased the minimum initiation voltage occurs at lower voltage at constant pressure, as shown by the Paschen-Law Curve (Figure 26).

The test conditions for simulating a given operating pressure and temperature can be calculated by using this relationship derived from the ideal gas law:

$$P_t = P_o \left[\frac{273 + t_t}{273 + t_o} \right] \quad (\text{Volume being constant}) \quad (3-24)$$

where:

- t_o = operating temperature in degrees Celcius
- t_t = test temperature in degrees Celcius (usually room temperature)
- P_o = operating pressure in N/m^2
- P_t = test-chamber pressure in N/m^2

3.3.6 Impressed Voltage. Partial discharges are counted with a pulse height analyzer or similar instrument when dc measurements are conducted. The random nature of the discharges make quantitative measurements difficult, especially with capacitors for which most test apparatus is designed to evaluate a 10 picofarad capacitor. With a large capacitor, say 1.0 μ fd, a small reading of 10 picocoulombs represents an actual 100 picocoulomb discharge inside the capacitor void--a very damaging discharge. With transformers, circuit boards, and inductors the readings are realistic. Freuger³⁵ has shown that the ratio of charge transferred in a dielectric void to the change in charge observed in the external circuit (R_{ct}) is:

$$R_{ct} = \frac{\text{charge transfer in the void}}{\text{change in the external pulse}} = \frac{t}{kd} \quad (3-25)$$

where: d is the thickness of the cavity
 t is the thickness of the dielectric

35) F. B. Freuger, Discharge Detection in High Voltage Equipment, Elsevier, 1964

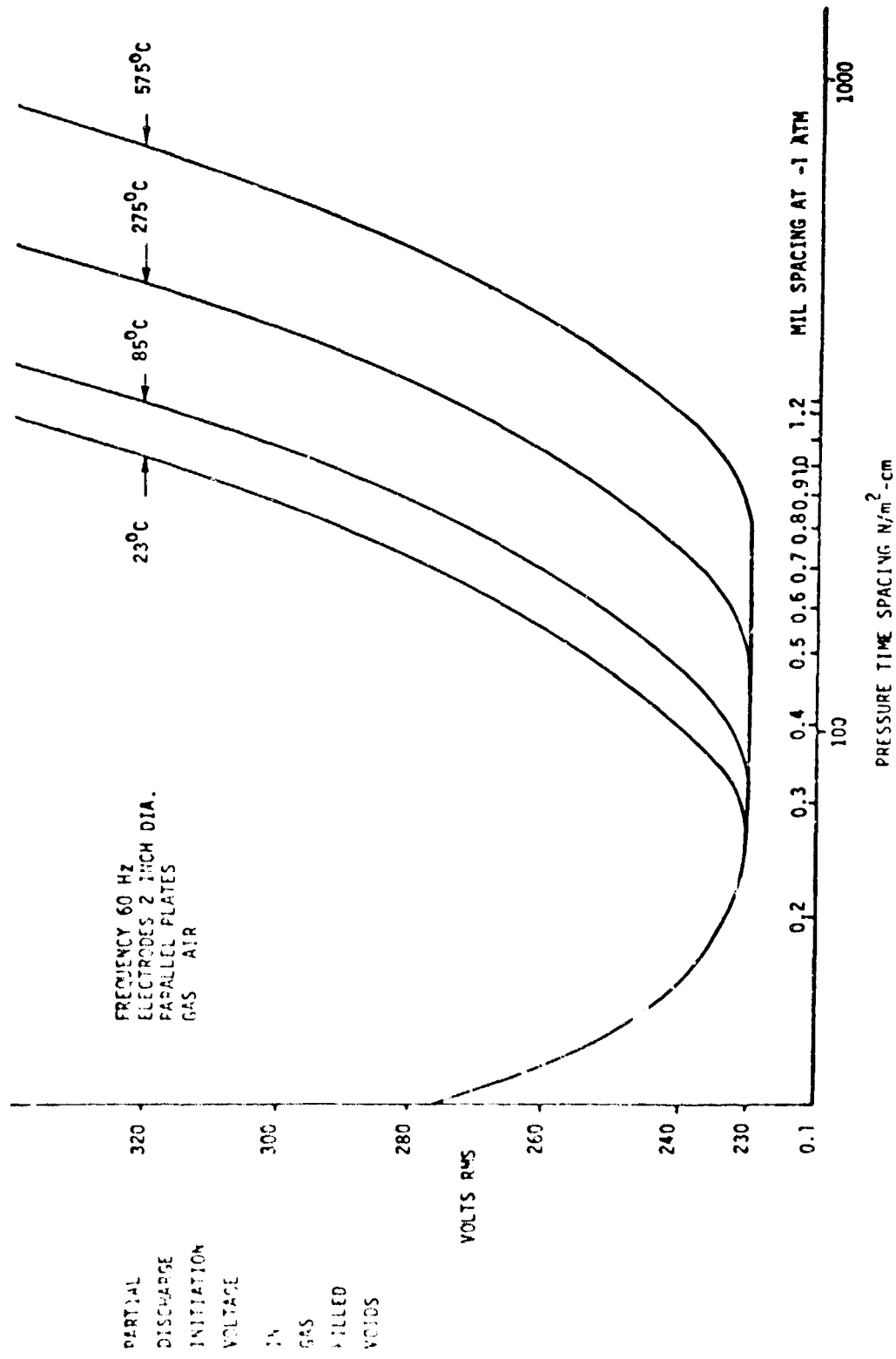

FIGURE 26. PRESSURE TIMES SPACING AS A FUNCTION OF TEMPERATURE

For example: if a void in a dielectric has these features:

$$t = 0.017$$

$$k = 3.4$$

$$d = 0.001$$

then:

$$R_{ct} = \left(1 + \frac{t}{kd}\right) = \left(1 + \frac{0.017}{3.4 \times 0.001}\right) = 6$$

Thus, a 10 pc reading on a corona detection instrument would represent a 60 pc discharge in the capacitor. A 60 pc discharge would damage a typical capacitor.

With 60-Hz ac voltages, the partial discharge counts increase significantly as applied voltage is raised above the initiation voltage. With ac superimposed upon a dc voltage, the partial discharge pulses decrease in both magnitude and number as the percent dc voltage (of dc voltage, rms) is changed from 5 percent to 200 percent. The loss tangent of the material also decreases significantly (Figure 27).

Raising the frequency of ac reduces the voltage at which partial discharge initiates, as shown in Figure 28 for spacecraft epoxies. The initiation voltage is relatively constant for frequencies up to 2kHz. Above 2kHz there is a significant decrease. Much of this decrease can be attributed to the gaseous breakdown within voids, a prime contributor to the partial discharges.

The effect of a square wave is similar to that of adding an impulse to an ac voltage. R.J. Densley³⁶ developed the technique of analyzing square waves. He found that the leading edge of a square wave will have the same effect as an ac voltage with an impulse at the zero voltage point on the sine wave. The impulse from the square wave will initiate partial discharges which may continue throughout the waveform. Most

36) R. J. Densley, "Partial Discharges in Electrical Insulation Under Combined Alternating and Impulse Stresses," IEEE, Transactions on Electrical Insulation, Vol. EI-5, No. 4, December 1970, pp 96-103.

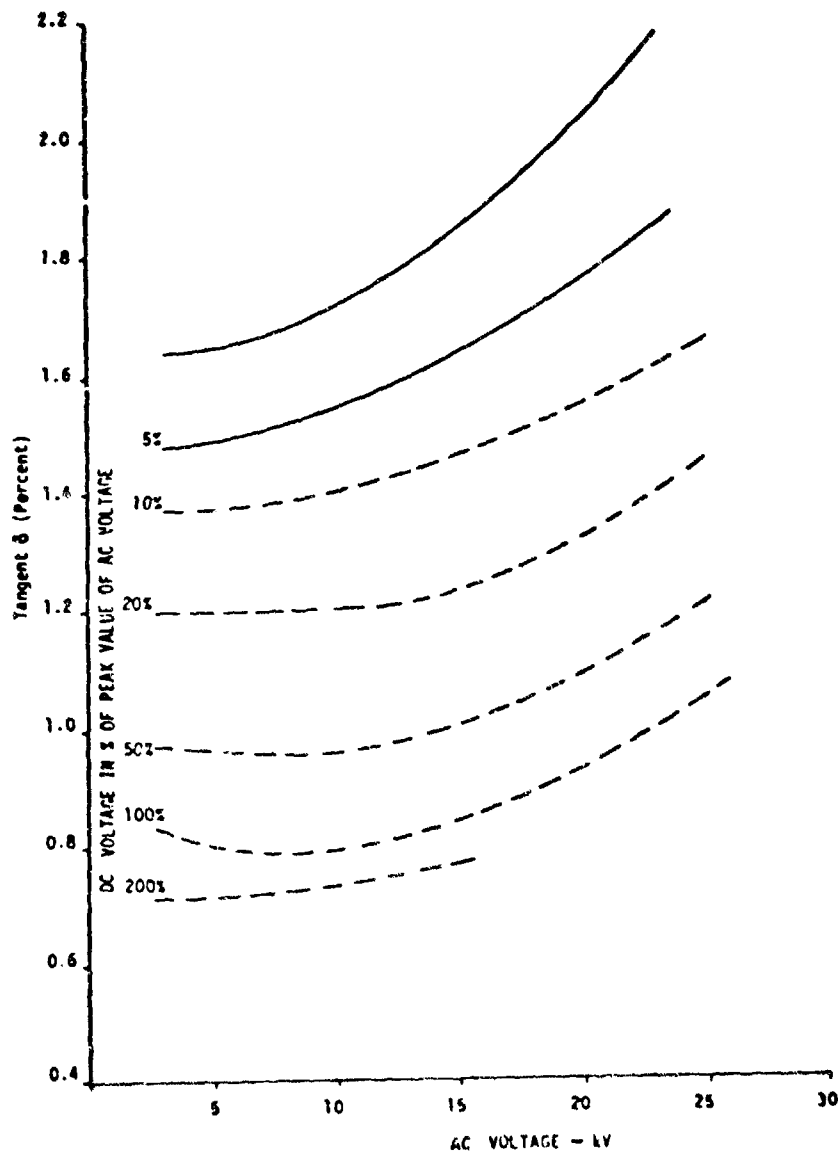

FIGURE 27. DEPENDENCE OF TAN δ ON THE AC VOLTAGE WITH SIMULTANEOUS DC VOLTAGE. IMPREGNATED PAPER CABLE INSULATION. 96.0°C, 50 Hz.

of the discharges occur immediately after the impulse with few or none at the end of the constant voltage plateau. The quantity of the discharges and their duration depends upon the amplitude of the square wave, the reverse stress across the void or crack after the leading edge passes, and the frequency of the square waves.

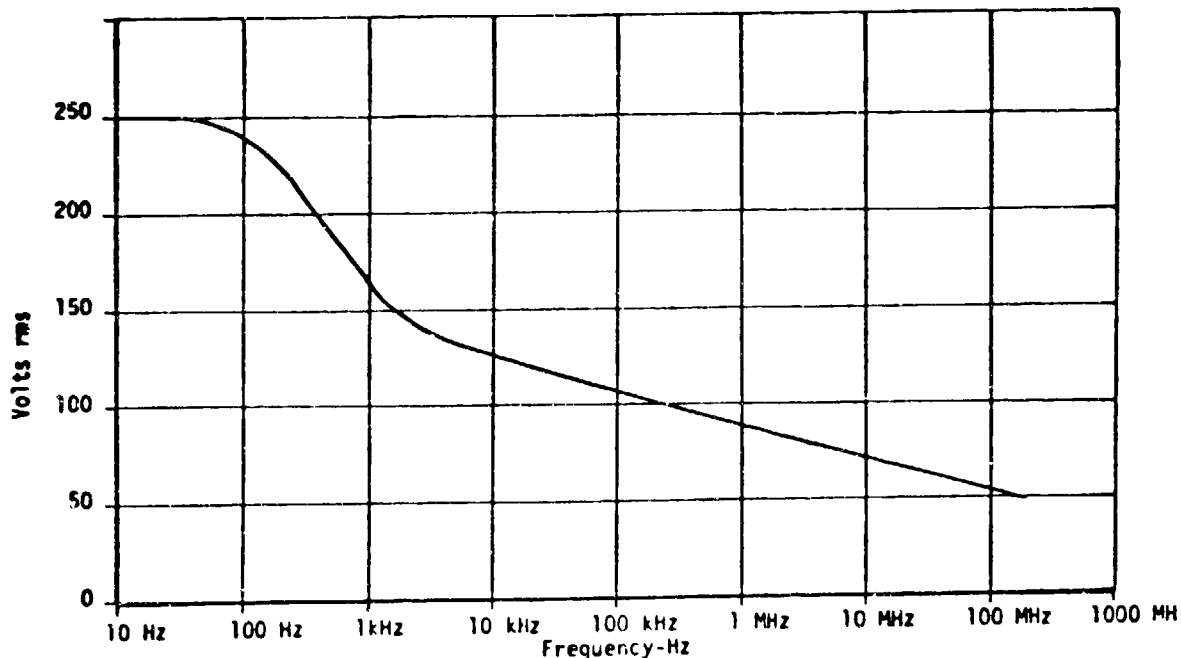

FIGURE 28. LOWER BREAKDOWN VOLTAGE RESULTS FROM HIGHER FREQUENCY

3.4 Surface Effects. In this section, the term "flashover" means that the surface of a solid insulator has become so conductive that it can sustain the flow of substantial current from one high-voltage electrode to the other. Elsewhere in this manual, the term "flashover" also refers to the breakdown of a gas dielectric.

Current flowing across a surface of an insulator, especially when slightly wetted and containing a conductive contaminant, may produce enough heat to generate a track of carbon, which becomes a conductive path tending to reduce the capability of the insulator to resist the voltage. With some materials, the surface erodes, but no "track" is produced. Fillers effectively reduce the tracking tendency of organic materials. Eroding materials, such as acrylics do not require filler protection. Obviously, no tracking is the ideal requirement for an organic insulator. Tracking can also be controlled by reducing the volts per millimeter stress on the surface. Petticoat insulation configurations lengthen the surface creepage path to

reduce stresses tending to cause tracking.

When new, cycloaliphatic epoxy with inorganic filler is applied to the surface of a laminate, the finished product can withstand higher voltage stress than porcelain. Surface erosion and exposure to ultra violet radiation will degrade the epoxy to where it is inferior to the porcelain. In one application having a glass-cloth epoxy-based laminate coated with cycloaliphatic epoxy, the surface was stressed at a voltage of over 45kV/cm impulse and 35kV/cm dc. However, the atmosphere was sulfur hexafluoride atmosphere, and such a high voltage-stress is not recommended for long life equipment.

The flashover voltage was measured between 1.9-centimeter diameter washers on an uncoated glass epoxy-band laminate (Figure 29). The washer was spaced one to four centimeters apart. Shown in Figure 30 is the flashover voltage as a function of spacing at three frequencies. The impulse and steady-state flashover voltage stress is shown for the same configuration in Table 6.

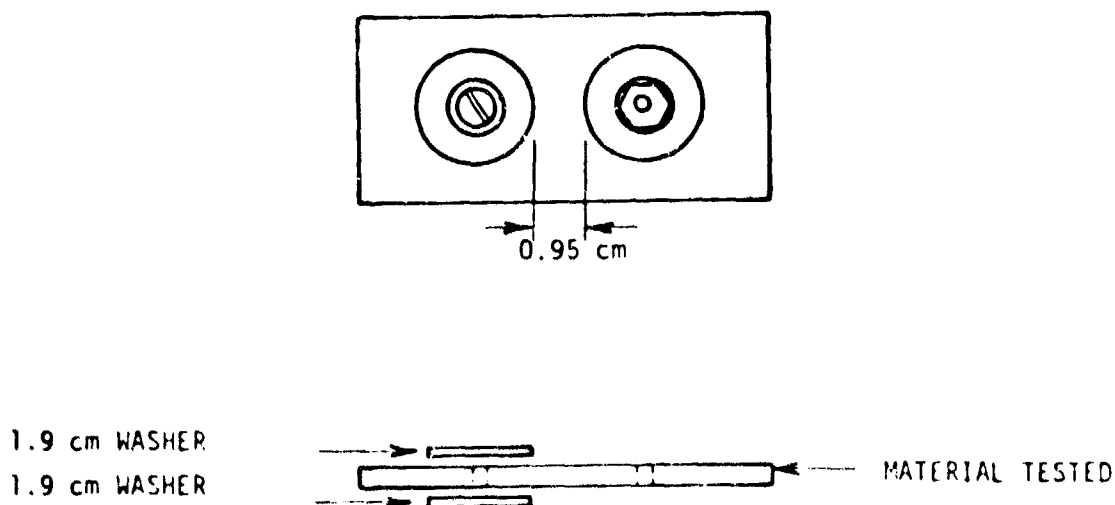

FIGURE 29. FLASHOVER FIXTURE

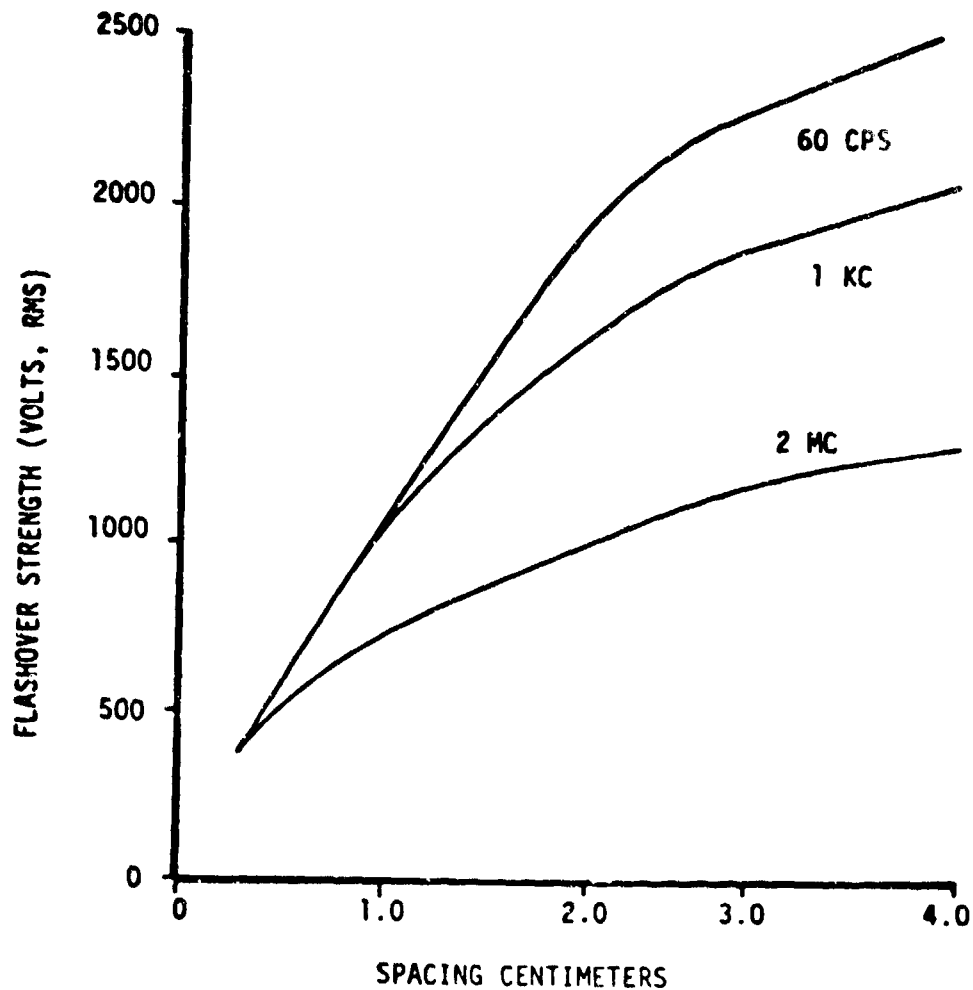

FIGURE 30. EFFECT OF SPACING ON FLASHOVER STRESS

3.4.1 Effect of Temperature On Flashover Strength. It is both interesting and useful to determine the relationship between flashover strength at 25°C and that which would prevail at some other temperature, T. For gaseous breakdown in a uniform field, this relationship involves the ratio of the gas densities at the two temperatures. In order to test this relationship, it is only necessary to multiply the 25°C value by the factor $(25 + 273)/(T + 273)$, which is the inverse ratio of the absolute temperatures involved. This ratio is part of the well-known air density correction factor, which is the commonly used in spark-gap measurements over a considerable range of density and gap

TABLE 6
COMPARISON OF STEADY-STATE AND IMPULSE FLASHOVER STRESS,
V/MM (PEAK) FOR GLASS EPOXY-BAND LAMINATES

<u>Test</u>	<u>Breakdown Stress,</u> <u>Volts/mm</u>
Steady-State	
60Hz	1410
dc positive	1490
dc negative	1670
Impulse	
60Hz	1410
dc positive	1710
dc negative	1860

length. The broken lines in Figure 31 show the values which are obtained when this factor is applied to the 25C flashover values.

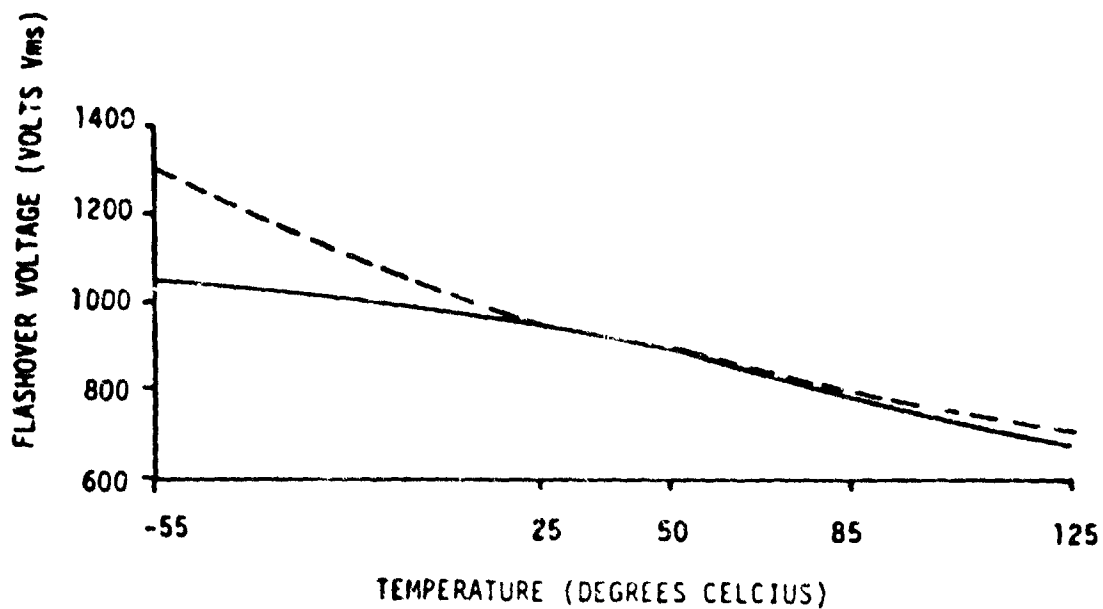

FIGURE 31. EFFECT OF TEMPRATURE ON 60 Hz FLASHOVER STRESS

3.4.2 Other Effects. All materials have lower flashover strength at higher frequencies. The example in Figure 32 illustrates the magnitude of change.

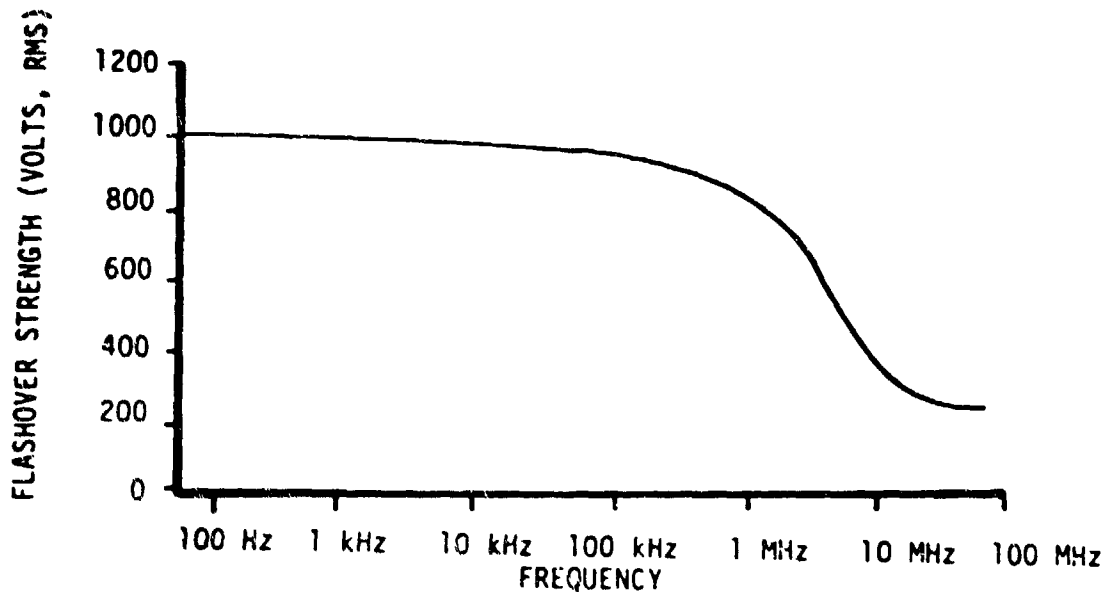

FIGURE 32. EFFECT OF FREQUENCY ON FLASHOVER STRENGTH FOR CONFIGURATION SHOWN IN FIGURE 29

High dielectric constant materials have much lower resistance to surface voltage creep than the low dielectric constant materials. Figure 33 illustrates the advantage in selecting the correct dielectric constant insulation. The "breakdown factor" in the illustration represents the results of many measurements showing how a decreasing flashover voltage can be expected across dielectric when insulations with progressively higher dielectric constants are tested.

A bibliography on surface flashover, surface creepage, and tracking on or within solid insulation is cited in References 37 through 53.

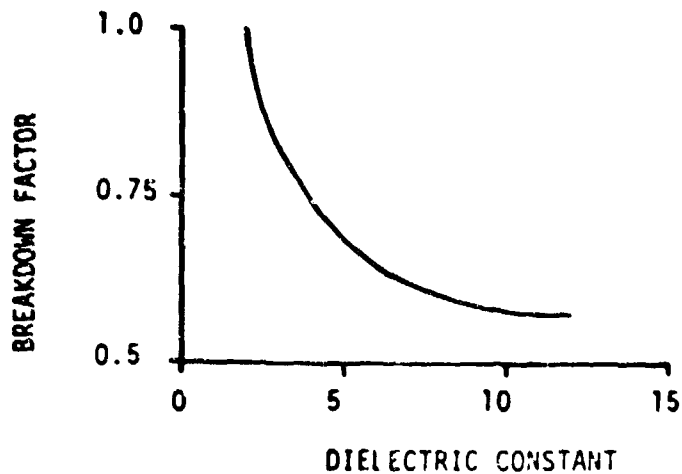

FIGURE 33: VARIATION OF VOLTAGE BREAKDOWN WITH CHANGING INSULATION DIELECTRIC CONSTANT

- 37) G. Alex, (FIMAG Finsterwalde, East Germany): "Tracking Resistance of I-v Insulating Materials," (Beitrag zur Festigkeit von Isolierstoffen des Niederspannungsbereichs gegen Kriechstoeme), *Elektrie*, Vol. 23, No. 9, p 364-6, Sept. 1969. *IEEE Trans. Elect. Insul.*, Vol. EI-1, No. 1, March 1965.
- 38) N. M. Bashara, F. M. Green and D. Lederer, "Pulse Height and Temporal Distribution at Dielectric Surfaces under Corona," *IEEE, Trans. Electrical Insulation*, Vol. EI-1, No. 1, pp. 12-18, March 1965.
- 39) M. V. Billings, and K. W. Humphreys, "An Outdoor Tracking and Erosion Test of Some Epoxy Resins," *IEEE, Trans. on Electrical Insulation*, EI-3, No. 3, August 1968, p. 62-70.
- 40) M. J. Billings, A. Smith, and R. Wilkins, "Tracking in Polymeric Insulation," *IEEE, Transactions on Electrical Insulation*, Vol. EI-2, No. 3, p. 131-6, December 1967.
- 41) M. J. Billings, L. Warren, and R. Wilkins, "Thermal Erosion of Electrical Insulation Materials," *IEEE, Trans. on Electrical Insulation*, Vol. EI-6, No. 2, June 1971, p. 82-50.

- 42) J. J. Chapman, L. J. Frisco and J. S. Smith, "Dielectric Failure of Volume and Surface Types," AIEE Transactions, Communications, & Electronics, Vol. 74, Pt. I, p. 349-356, July 1955.
- 43) A. V. Dmitriev and Chien-Chien Chiang, "Changes in the Properties of Dielectric Surfaces Under the Effects of a Gas Discharge," Zh. Tekhn. Fiz. 36, (In Russian); English Translation: Soviet Phys.-Tech. Phys. 11, p. 547-551, 1966.
- 44) T. A. Dakin and G. A. Mullen, "Continuous Recording of Outdoor Insulator Surface Conductance," IEEE, Transactions on Electrical Insulation, EI-7, No. 4, December 1972, p. 169-175.
- 45) L. J. Frisco, "The Flashover Strength of Solid Dielectrics," AIEE Transactions on Power Apparatus & Systems, Vol. 75, Pt. III, p. 77-83 April 1956.
- 46) Mo. Kurts, "Comparison of Tracking Test Methods," IEEE, Transactions on Electrical Insulation, Vol. EI-6, No. 2, June 1972, p. 76-81.
- 47) J. H. Mason, "The Resistance of Sheet Insulation on Surface Discharges," Proc. Institute of Electrical Engineers, Vol. 107A, P. 551-568, Dec. 1960.
- 48) M. Olyphant, "Arc Resistance," Pt. 1, "Tracking Processes in Thermosetting Materials," Am. Soc. Testing Materials, Bull. 181, p.60-67, April 1952
- 49) M. Olyphant, "Arc Resistance," Pt. 2, "Effect of Testing Conditions on Tracking Properties of Thermosetting Materials," Am. Soc. Testing Materials, Bull. 185, p. 31-38, October 1952.
- 50) T. Orbeck and R. G. Niemi, "Study of Surface Leakage Current and "Dry-Band-Arcing" on Synthetic Insulation Materials and Porcelain Under Wet High Voltage Conditions," Conference on Electrical Insulation and Dielectric Phenomena, 1973 Annual Report, p. 43-50.
- 51) Y. Toriyama, H. Okamoto and M. Kanazashi (Musashi Inst. Technology, Tokyo, Japan), "Breakdown of Insulating Materials by Surface Discharge," IEEE Transactions on Electrical Insulation, Vol. EI-6, No. 3, p. 124-9, September 1971.
- 52) C. F. Wallace and C. A. Bailey, "Dip-Track Test," IEEE, Transactions on Electrical Insulation, Vol. EI-2, No. 3, Dec. 1967, p. 137-140.
- 53) R. Winans, "Safe Minimum Distances for Electrical Creepage and Clearance," Electrical Manufacturing, Vol. 51, No. 1, p. 78-83, January 1953.

3.5 Liquid Dielectrics. Liquid dielectrics may be used as insulators and as a heat transfer medium. Often liquid dielectrics are used in conjunction with solid insulations such as papers, films, and composite materials. By eliminating air or other gases, liquid dielectrics improve dielectric strength of the insulation system. They are also self-healing, in contrast to solid dielectrics, for the affected area of a failure caused by a temporary over-voltage is immediately reinsulated by fluid flow back to it.

Liquids used as insulators are mineral oils, askarels, silicone oils, fluorocarbons (fluorinated liquids), vegetable oils, organic esters including castor oil, and polybutenes (polyhydrocarbon oils).

3.5.1 Selection. In selecting a liquid dielectric, its properties must be evaluated in relation to the application. The most important are dielectric strength, dielectric constant and conductivity, flammability, viscosity, thermal stability, purity, space factor, flash point, chemical stability, and very important--compatibility with other materials of construction and the local atmosphere.

Disadvantages which always accompany the use of liquid dielectrics are cost, weight, and temperature limit. Other disadvantages with many liquids are color stability, oxidation and contamination, and deterioration of materials in contact with the liquid. Deterioration of materials generates moisture, evolves gas, forms corrosive acids, produces sludge, increases dielectric loss, and decreases dielectric strength.

The selected liquid should provide the best required properties, consistent with keeping disadvantages within the acceptable limits.

3.5.2 Effect of Temperature. The temperature of a liquid dielectric affects its life and stability; an chemical deterioration reactions usually proceed faster at higher temperatures. A pure liquid, in the absence of water or oxygen, would be very stable at rather high temperatures.
54

Temperature also affects the dielectric constant of a liquid dielectric.

As temperature increases, fluid viscosity decreases and the higher mobility of the ions permits increased conduction⁵⁵ (Figure 34). Refining techniques, additives, and blending of liquids are used to thermally upgrade liquid dielectrics.^{56,57,58} The normal usable temperature range of liquid dielectric classes is shown in Figure 35.⁵⁹

3.5.3 The Effect of Moisture. Water is soluble to some extent in all insulating liquids. Water usually decreases dielectric strength and increases dielectric loss. Moisture dissolved in pure mineral oil does not affect dielectric strength until it separates from the oil solution and deposits on conductors, solid insulation surfaces, or on solids floating in the oil. However, oil invariably contains suspended fibers, dust, and other contaminants, so the presence of moisture usually lowers the dielectric strength. Polar contaminants dissolved in the oil give moisture its greatest degradation effect on dielectric strength. The effect of moisture varies among the other liquid dielectrics.

- 54) Insulation, Director/Encyclopedia Issue, Lake Publishing Co., Vol. 15, No. 8, June/ July 1969, Copyright 1969.
- 55) I. Y. Megahed and A. A. Zaky, "Influence of Temperature and Pressure on Conduction Currents in Transformer Oil," IEEE Transactions on Electrical Insulation, Vol. EI-4, No. 4, December, 1969, pp. 99-103.
- 56) Akira Miyoshi, "A New Additive for Improving the Thermal Aging Characteristics of Kraft Insulating Paper," IEEE Transactions on Electrical Insulation, Vol. EI-10, No. 1, March 1975, pp. 13-17.
- 57) B. P. Kang, "Thermal Dependency of Viscosity, Power Factor, and Ion Content on Electrical Insulating Oils-II Characteristics of Blended Insulating Oils," IEEE Transactions on Electrical Insulation, Vol. EI-2, No. 1, April 1967, pp. 55-69.
- 58) E. J. McMahon and J. O. Punderson, "Dissipation Factor of Composite Polymer and Oil-Insulating Structures on Extended Exposure to Simultaneous Thermal and Voltage Stress," IEEE Transactions on Electrical Insulation, Vol. EI-3, No. 3, Sept. 1973, pp. 92-97.
- 59) F. M. Clark, Insulating Materials for Design and Engineering Practice, John Wiley and Sons, Inc., Copyright 1962.

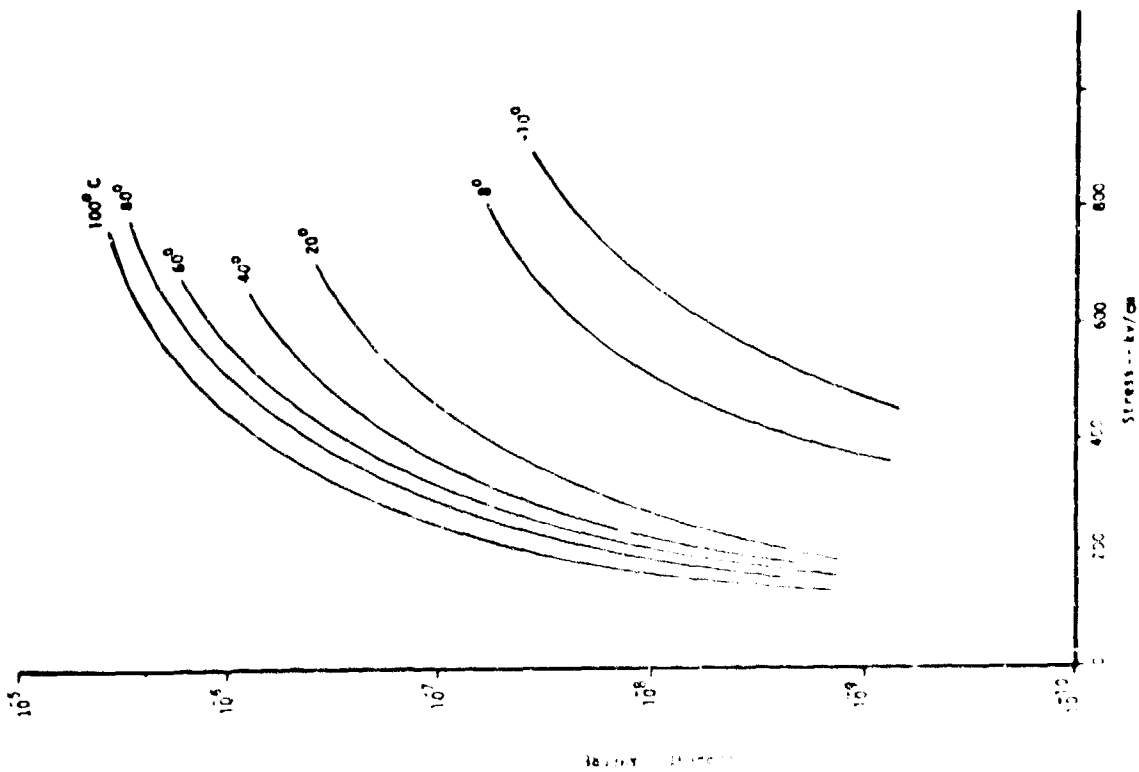

FIGURE 34. EFFECT OF TEMPERATURE ON CONDUCTION CURRENT IN DEGASSED TRANSFORMER OIL

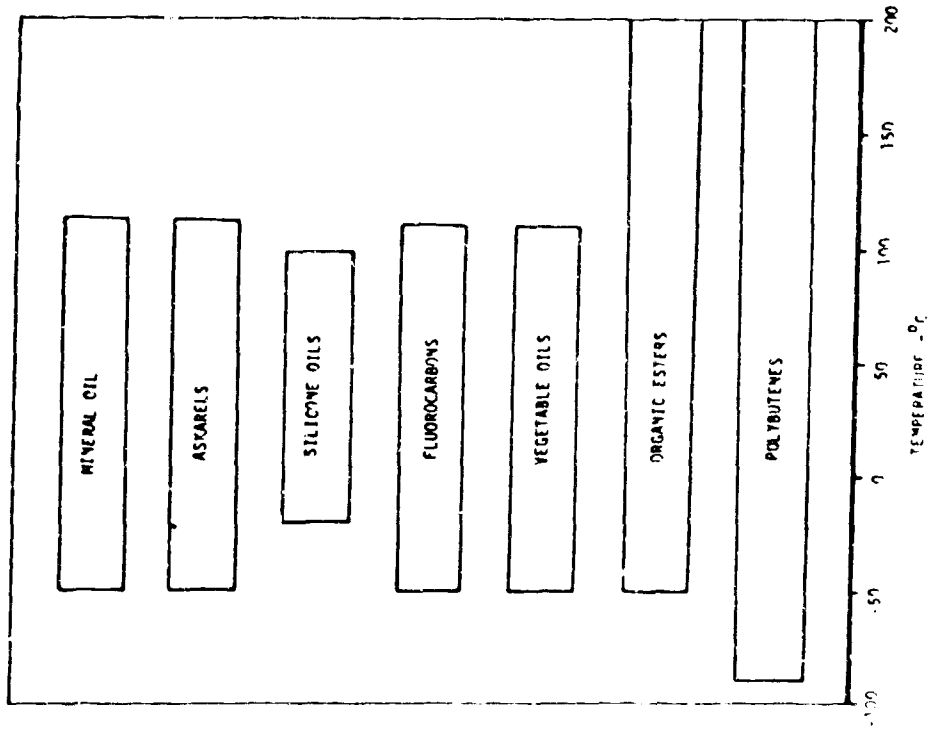

FIGURE 35. NORMAL USABLE TEMPERATURE RANGE OF LIQUID DIELECTRIC CLASSES

In using liquid dielectrics to impregnate cellulosic insulations in transformers, cables, and capacitors, the rate of increase of water solubility in the liquid with increasing temperature is important. When the rate increase in water solubility in the liquid is different from that in the cellulosic insulation, changes in temperature can make the dissolved water separate from the liquid. Such a separation leads to the formation of liquid-water emulsions and severe dielectric degradation.

3.5.4 Dissolved Gas. The effects of gas absorption and liberation in a liquid dielectric must be considered for long term, successful operation.⁶⁰ This is especially true when the liquid is used to impregnate solid dielectrics, as in capacitors and cables.

Changes in pressure can make dissolved gases evolve from a liquid. Also, temperature affects the solubility of gas, so heating can cause dissolved gas to evolve from the liquid. Corona will start gas bubbles in electric fields, leading to eventual dielectric breakdown. Thus, liquids used, as impregnates, must have a low, stable gas content.

3.5.5 Breakdown Phenomena. Parameters affecting dielectric breakdown in insulating liquids include electrode materials, electrode surface area and shape, manufacturing treatments, contamination, and deterioration. Birke, Lackey, and Palmer⁶¹ have developed methods of finding the highest stressed liquid volumes between electrodes, enabling them to predict accurately the dielectric breakdown for different electrode configurations.

Manufacturers treat liquid dielectrics in various ways to improve their properties. To obtain the highest initial dielectric values in mineral oil, there is no danger from over-refining. However, over-refining can adversely affect the stability of the oil and its useful lifetime. The oil must be limited in its aromatic hydrocarbon content, the presence of which decreases the initially high dielectric values of highly refined oil.

60) B. P. Kang, "Stability of Electrical-Insulating Oils," IEEE Transactions on Electrical Insulation, Vol. EI-5, No. 2, June, 1970, pp. 41-46.

61) P. V. Birke, J. Lackey and S. Palmer, "Determination of Highly Stressed Volumes in Oil Dielectrics," IEEE Transactions on Electrical Insulation, Vol. EI-7, No. 3, September, 1972, pp. 139-144.

Liquid dielectrics deteriorate as they are contaminated by sludge, soaps, oxides, and condensation products. These contaminants form faster at higher temperatures and in the presence of reactants, catalysts, nitrogen, sulphur, and acids in the liquid. Ions are found in these contaminants. J.A. Kok⁶² theorizes that colloidal ions with high permittivity drift toward the high electrical stress regions where they form chains of dipoles in between the electrodes. Highly stressed regions may be the edges of metal foil electrodes, at paper folds, and where polar contaminants have been absorbed by paper dielectric.

The colloidal dipoles will be separated from each other by a thin layer of oil until they overcome the energy barrier of the oil layers. The act of overcoming the energy barriers, called flocculation, may be aided by the other contaminants. As the chains of dipoles become conducting paths, gas is developed by electrolysis or evaporation. After that ionization and breakdown soon follow. The whole process can occur within a fraction of a second.

3.5.6 Mineral Oil. Mineral oil is the most widely used of all liquid dielectrics. Average characteristics of mineral oil used in common dielectric applications is shown in Table 7.⁵⁹ Being a product of crude petroleum, both the source and the refining process affect the end quality of the oil. The refining problem is to remove deleterious materials such as sulphur and nitrogen without removing or destroying the crude-oil constituents that are necessary for long life and stability, such as the aromatic hydrocarbons. Like inhibitors which are added during the manufacture of mineral oil, aromatic hydrocarbons slow down the rate of oxidation (Figure 36).

The contaminate products of oxidation reactions are sludge, asphalt, acids, organic esters, soaps, and oxides. Oil color, as an index of the degree of refinement for unused oils, is also a rough measure of deterioration of oil in service. Cloudiness indicates the presence of moisture, sludge, particles of insulation, products of metal corrosion, or other

62) J. A. Kok, Electrical Breakdown of Insulating Liquids, Interscience Publishers, Inc., Copyright 1961.

TABLE 7
THE AVERAGE CHARACTERISTICS OF MINERAL INSULATING OIL

Property	For Use in Solid Type Cables	For Use in Capacitors and Hollow Core Cables	For Use in Transformers, Switches & Circuit Breakers
Condition	Clear	Clear	Clear
Viscosity	100" (98.9°C)	100" (37.8°C)	58" SSU (37.8°C)
Specific Gravity	.930 (15.5/15.5°C)	.885	.885 (15.5/15.5°C)
Color	2.3 (NPA)	1 or less (NPA)	1 or less (NPA)
Neutralization Number	.02 (Mg KOH/gram)	.02 (Mg KOH/gram)	.02 (Mg KOH/gram)
Flash Point (open cup)	235°C	165°C	135°C
Burn Point (open cup)	280°C	185°C	148°C
Pour Point	-5°C	-45°C	-45°C
Free Sulfur	nil	nil	nil
Total (fixed) Sulfur	.35%	.15%	.15% or less
Evaporation (8 hrs/100°C)	8%
Dielectric Strength	30 kv	30 kv	30 kv
Specific Heat (30-35°C)412	.4252
Power Factor (100°C)	.001	.001	.001
Chlorides and Sulfates	nil	nil	nil
Resistivity (100°C)	1-10x10 ¹² (ohm-cm)	50-100x10 ¹² (ohm-cm)	1-10x10 ¹² (ohm-cm)
Coef. of Expansion	.00075		.00070
Specific Optical Dispersion	115-120	115-120	110-115
Thermal Conductivity39 cal/cm/sec/°C
Refractive Index (25°C)	1.4828
Aniline Point	169°F (76°C)

undesirable suspended materials. Contaminants are introduced into mineral oils from:

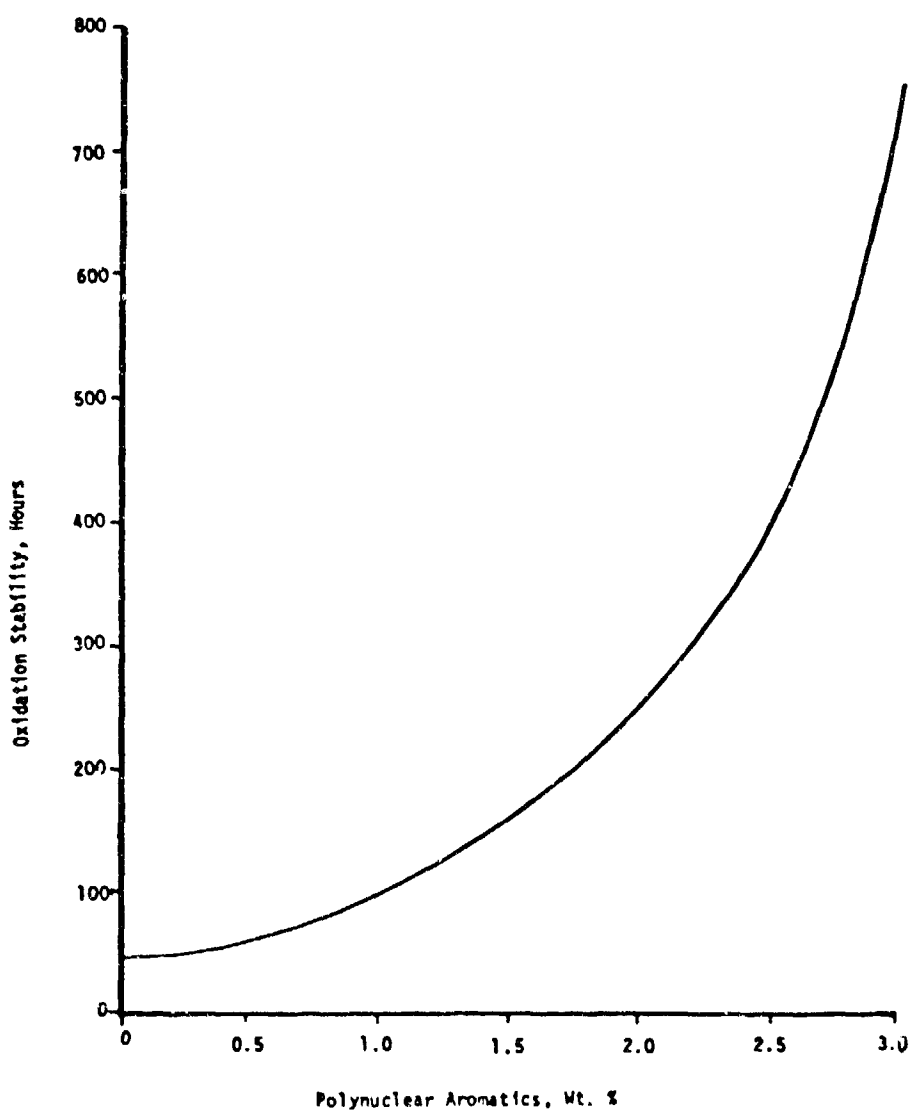

FIGURE 36. OXIDATION OF TRANSFORMER OILS IN ASTM D943 TEST. HOURS TO INTERFACIAL TENSION OF 15 DYN/CM VERSUS POLYNUCLEAR AROMATIC CONTENT OF THE OIL

- a) Improper manufacturing and refining methods.
- b) Improper handling and shipping procedures.
- c) Oxidation of the oil.
- d) Soluble polar particles produced by moisture.
- e) Improper materials of construction or other insulations.

Construction materials which may or may not be used in contact with mineral oils for long periods of time are shown in Table 8. The interfacial test is a sensitive detector of small concentrations of polar contaminants and oxides. This and other tests necessary in specifying electrical insulating oils are discussed by Clark⁵⁹ and by Simo.⁶³ New methods of accelerated testing and rapid measurement are presented by Hiro and Saganuma.⁶⁴

Three types of loss mechanisms are known to exist in mineral oils, all due to contaminants; (1) dipole orientation, (2) space-charge orientation, and (3) ionic conduction.⁶⁵ The magnitude of each of these losses in an oil depends on oil temperature, power frequency, oil viscosity, and the degree of contamination of the oil. These losses, particularly with respect to oil impregnated paper, are discussed by Bartnikas.^{66, 67}

- 63) Simo, "Large Scale Dielectric Test of Transformer Oil with Uniform Field Electrodes," IEEE Transactions on Electrical Insulation, Vol. EI-5, No. 4, December, 1970, pp. 121-126.
- 64) T. Hino and T. Saganuma, "Rapid Measurement of the Deterioration of Oil-Immersed Paper," IEEE Transactions on Electrical Insulation, Vol. EI-7, No. 3, September, 1972, pp. 122-126.
- 65) R. Bartnikas, "Dielectric Loss in Insulating Liquids," IEEE Transactions on Electrical Insulation," Vol. EI-2, No. 1, April 1967, pp. 33-54.
- 66) R. Bartnikas, "Electrical Conduction in Medium Viscosity Oil-Paper Films-Part I," IEEE Transactions on Electrical Insulation, Vol. EI-9, No. 2, June 1974, pp. 57-63.
- 67) R. Bartnikas, "Electrical Conduction in Medium Viscosity Oil-Paper Films, Part II," IEEE Transactions on Electrical Insulation, Vol. EI-9, No. 3, September 1974, pp. 85-91.

New methods of refinement, new additives, new inhibitors, treatments, and new oil blends are being discovered and developed to improve critical parameters of oils without degrading the other parameters in neither oil or oil-solid-dielectric systems.^{56,57,68,69,70}

TABLE 8

MATERIALS COMPATIBILITY WITH MINERAL OILS

<u>Compatible Materials</u>	<u>Uncompatible Materials</u>
Alkyd resins	Acrylic plastics
Cellulose esters	Asphalt
Cork	Chloride flux
Epoxy resins	Copper (bare)
Masonite	Fiber board
Melamine resins	Greases
Nylon	Polyvinyl chloride resins
Phenol-formaldehyde resins	Rubber (natural & synthetic)
Polyamide-imides	Saran resins
Polyester-imides	Silicone resins
Polyethylene Terephthalate (Mylar)	Tars
Polyurethane	Waxes (petroleum)
Pressboard	
Shellac	
Silicone rubber	
Wood	

- 58) D. P. Kang, "Thermal Dependency of Viscosity, Power Factor, and Ion Content on Electrical Insulating Oils-III Predictions of Power Factor of Oil Blends through the Concept of Ion Content," IEEE Transactions on Electrical Insulation, Vol. EI-2, No. 2, August 1967, pp. 121-128.
- 69) Y. N. Rao and T. S. Ramu, "Determination of the Permittivity and Loss Factor of Mixtures of Liquid Dielectrics," IEEE Transactions on Electrical Insulation, Vol. EI-7, No. 4, December 1972, pp. 195-199.

3.5.7 Askarels. Askarels are synthetic liquid dielectrics used primarily in capacitors and transformers. They are chemically stable, non-flammable, and oxidation resistant. Commercial askarels are derived from aromatic hydrocarbons by chlorination to the extent that a chemical equivalent of chlorine and hydrogen is present in each molecule. When an askarel is decomposed by an electric arc, only non-flammable gaseous mixtures of hydrogen chloride and carbon evolve. Typical characteristics of askarels are shown in Table 9.⁵⁹

Askarels provide dielectric constants that are more than twice those of mineral oils. When used for impregnating paper capacitors, their high dielectric constants permit large decreases in capacitor size. Furthermore, askarels are better than mineral oil with respect to matching the dielectric constant of capacitor paper. This contributes to a more evenly distributed dielectric stress in the capacitor.

The askeral liquids do not oxidize as oils do, but they attack and dissolve a wider range of materials than mineral oils do. A partial list of construction materials which may or may not be used with askarels is shown in Table 10.

The dielectric strength of synthetic liquids is little affected by contaminants, extended high temperatures, or moisture content below saturation. The dielectric loss, though, is increased by contaminants and moisture content.

3.5.8 Silicone Oils. Silicone oils most commonly used as liquid dielectrics are dimethyl silicone polymers. These silicones are characterized by a nearly flat viscosity-temperature relationship, resistance to oxidation, stability at high temperature, and excellent high frequency characteristics. They are unique in two important properties: (1) viscosity range from 1 to

70) E. R. Buntin, R. D. Wesselhoff, and E. O. Forster, "A Study of the Electrical Insulation Characteristics of Oil-Impregnated Polypropylene Paper," IEEE Transactions on Electrical Insulation, Vol. EI-7, No. 4, December 1972, pp. 162-169.

TABLE 9

TYPICAL CHARACTERISTICS AND USES OF ASKAREL
INSULATING LIQUIDS

Use	Capacitors	Capacitors	Transformers	Transformers
Condition (25°C)	Clear	Clear	Clear	Clear
Color	Yellow Tint	Light Yellow	Yellow Tint	Yellow Tint
Acid Value (mgKOH/gr)	< .01	< .01	< .01	< .01
Free Chloride ion	Nil	Nil	Nil	Nil
Specific Gravity (25°C)	1.40-1.45	1.54-1.55	1.54-1.55	1.55-1.57
Fire Point (°C)	None	None	None	None
Pour Point (°C)	0 to -7	6 to 12	-40 to -50	-35 to -40
Viscosity (37.8°C)	200 (SSU)	3000 (SSU)	42 (SSU)	54 (SSU)
(98.9°C)	40 (SSU)	46 (SSU)	--	33 (SSU)
(100°C)	1.2 ⁶ (E)	1.4 ⁰ (E)	--	--
Coef. of Expansion(25-65°C)	68 x 10 ⁻⁵	65 x 10 ⁻⁵	67 x 10 ⁻⁵	67 x 10 ⁻⁵
(cc/cc/°C)				
Heat Conductivity (40°C)	.091	.087	.087	.087
kcal/m/h/°C	1.623	1.638	1.607	1.614
Refractive Index (20°C)(D)				
Dielectric Strength(20-90°C)	200	200	200	200
Kv/cm (VDE)	350	350	350	350
VPM (ASTM)	5.3 (20°C)	5.0(20°C)	4.5(25°C)	4.2(25°C)
Dielectric Constant	4.4 (90°C)		3.9(100°C)	3.6(100°C)
Specific Resistance (90°C)	1-5 x 10 ¹²	1-5 x 10 ¹²	1-5 x 10 ¹²	1-5 x 10 ¹²
(ohm-cm)	.015	.015	.01-.05	.01-.05
Power Factor (90°C)				

TABLE 10
MATERIALS COMPATIBILITY WITH ASKARELS

<u>Compatible Materials</u>	<u>Incompatible Materials</u>
Asbestos	Polymers (natural & synthetic)
Cellulose ester resins (cured)	Rubber (natural & synthetic)
Cellulosic cords	Vegetable oil type paints
Cellulosic pressboard	Vegetable oil type varnishes
Cotton paper	
Epoxy resins (cured)	
Kraft paper	
Linen paper	
Paper	
Phenolic resins (cured)	
Polytetrafluoroethylene	
Polyurethane resins (cured)	
Silicone polymers	
Wood	

1,000,000 centistokes, and (2) stability in air to 150°C, and stability when not exposed to air at 200°C and higher.

Silicone liquids resist oxidation and do not form sludge as do mineral oils. Their stability in the presence of oxygen makes them low in fire and explosion hazard, even at temperatures up to 200°C.

3.5.9 Miscellaneous Insulating Liquids. Other liquid dielectrics include fluorocarbons, vegetable oils, organic esters, and polybutene liquids. They are not commonly used, and are not discussed here. For information concerning them, references 54 and 59 are suggested.

3.5.10 Filtering and Outgassing. Oils used as liquid dielectrics should be filtered before use and outgassed when installed. Mineral oils, vegetable oils, and organic esters should be outgassed at 85°C and at a pressure of 10 N/m² (0.7 torr), for four hours.

Oils depressurized to 10³ to 10⁵ N/m² (7 to 760 torr) have little change in conduction current at high voltage (to 680 KV/cm) at temperatures below 50°C. At 50°C and higher temperature the conduction current increases as the pressure is decreased below ambient pressure. This is caused by the release of dissolved gas, namely air and oxygen. Further experimental work in this field ⁷¹ has showed that the presence of air in oil reduces the affinity of dissolved gases to the oil and bubble formation is increased. This is a strong case for the thorough depressurization of oil.

Where possible, mineral oils and askarels while serving as high-voltage dielectrics, should be continuously circulated through activated alumina, for example by thermosyphon action. Such filtering by controlling contamination, limits the loss at dielectric strength in mineral oil and limits dielectric loss in askarel. ⁵⁹

Contaminated oils which do not have the required properties are treated by centrifuging, paper filtration or fuller's earth treatment. Treatment with fuller's earth removes oil soluble moisture, acids and other contaminants.

3.6 Cryogenic Temperatures. Cryogenics refers to the phenomena observed in liquified gases, solid materials and vacuum at temperatures below 100°K. This arbitrary temperature is the threshold below which the properties of dielectrics, liquids, and conductors change significantly.

3.6.1 Cryogenic Liquids. Cryogenic liquids which are likely to be encountered in high-voltage work are listed in Table 11. Their important

71) G. R. Dimelor, I. W. Mills, and J. J. Melchoire, "The Scope of Hydro-generation on a Refining Tool for the Manufacture of Transformer Oils," IEEE Transactions on Electrical Insulation, Vol. EI-4, No. 1, March 1969, pp. 7-12.

TABLE 11
BOILING POINTS OF GASES

Substance	Approximate Boiling Point at 1 Atmosphere	
	$^{\circ}\text{C}$	$^{\circ}\text{F}$
Helium	-269.9	-453.8
Helium	-268.9	-452.0
Hydrogen	-252.8	-423.0
Deuterium	-249.5	-417.1
Tritium	-248.1	-414.6
Neon	-246.0	-410.8
Nitrogen	-195.8	-320.4
Carbon Monoxide	-191.5	-312.7
Fluorine	-188.1	-306.6
Argon	-185.9	-302.6
Oxygen	-183.0	-297.4
Methane	-161.5	-258.7

physical properties are given in Table 12.⁷²

The cryogenic liquids which will probably be used in electrical insulating applications are helium (He^4), hydrogen, and nitrogen. Both hydrogen and nitrogen have higher breakdown voltages than conventional transformer oil, but liquid helium breaks down at a considerably lower voltage.

3.6.2 Dielectric Properties of Cryogenic Liquids. The dissipation losses of liquified helium, hydrogen, and nitrogen are so small they are hard to measure. Published figures for the loss tangent are relative rather than absolute. Comprehensive treatments of techniques for measuring the dissipation loss of cryogenic liquids are published by B.C. Belanger⁷³, and K.N. Mathes^{74,75}. Measurements of dissipation factor (tangent δ) made by K.N. Mathes^{74,75,76} are shown in Figures 37 and 38. Measurements were relative rather than absolute. The frequency dependence of the dissipation factor in Figure 36 may be an artifact of the measurement bridge elements.⁷⁴

Pressure does not have much influence on dissipation factor. The rapid increase with voltage stress is thought to be caused by charge injection at the electrodes, an effect that will be covered in the section on the theory of breakdown.

- 72) H. Weinstock, Cryogenic Technology, Boston Technical Publishers, Inc., Copyright 1969.
- 73) B. Belanger, "Dielectric Problems in the Development of Resistive Cryogenic and Super-conducting Cables," Conference on Electrical Insulation and Dielectric Phenomena, 1973 Annual Report, p. 486-493.
- 74) K. N. Mathes, "Dielectric Properties of Cryogenic Liquids," IEEE Transactions on Electrical Insulation, Vol. EI-2, No. 1, p. 24-32, April 1967.
- 75) K. N. Mathes, "Cryogenic Dielectrics," Conference on Electrical Insulation and Dielectric Phenomena, 1973 Annual Report, p. 547-580.
- 76) M. J. Jefferies and K. N. Mathes, "Dielectric Loss and Voltage Breakdown in Liquid Nitrogen and Hydrogen," IEEE Transactions on Electrical Insulation, Vol. EI-5, No. 3, p. 83-91, September 1970.

TABLE 12
PHYSICAL DATA FOR CRYOGENIC FLUIDS

Substance	Density		Volume Ratio		Heat of Vaporization cal/g
	Gas (NTP) ¹ g/l	Liquid (NBP) ² g/l	Gas (NTP) Liquid (NBP)	Gas (NTP) Liquid (NBP)	
He ⁴ Helium	0.1785	125	700.3		4.9
H ₂ Hydrogen	0.08988	71	789.9		108.0
N ₂ Nitrogen	1.251	808	645.9		47.6
Ne Neon	0.8999	1207	1341.1		20.5
F ₂ Fluorine	1.696	1510	890.0		41.2
Ar Argon	1.784	1400	784.0		39.0
O ₂ Oxygen	1.429	1142	799.2		50.9
CH ₄ Methane	0.7168	415	578.0		121.9

Notes: 1. NTP is Normal Temperature and Pressure 0°C, 10⁵N/m²
2. NBP is Normal Boiling Point at 760 mm

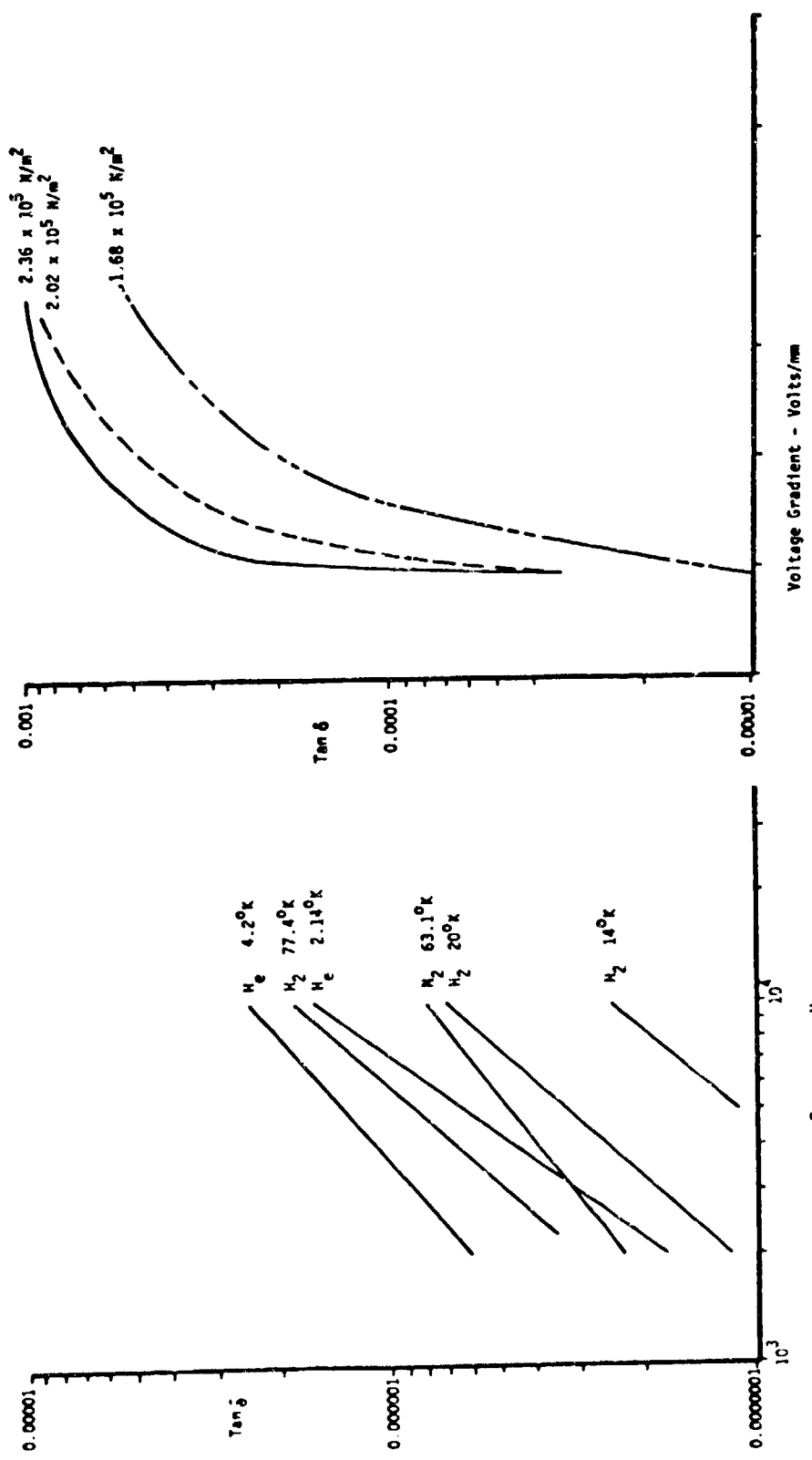

FIGURE 37. DISSIPATION FACTOR AT SEVERAL FREQUENCIES FOR LIQUID HYDROGEN, NITROGEN, AND HELIUM

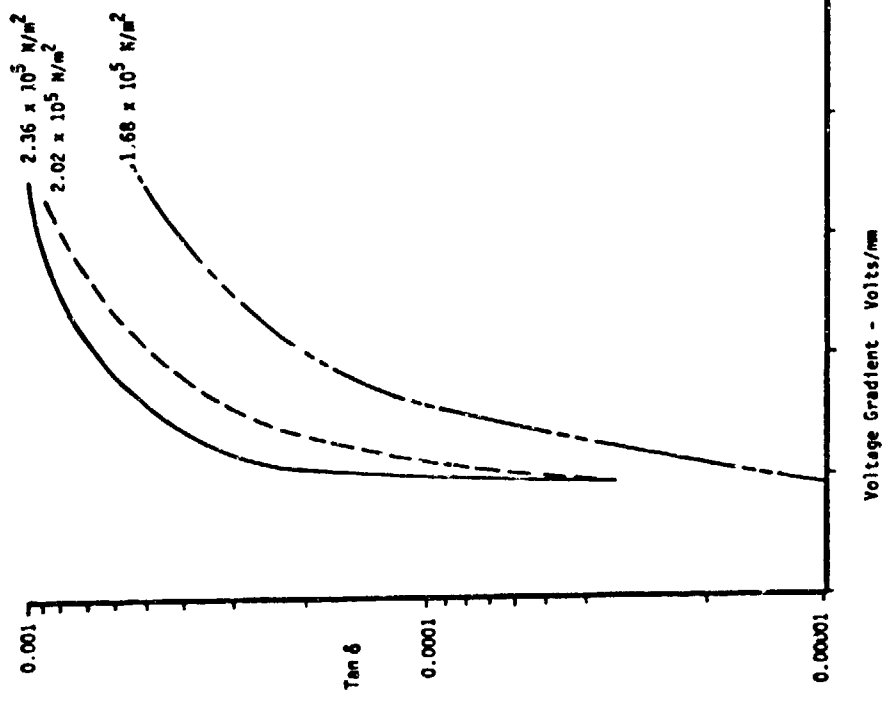

FIGURE 38. DISSIPATION FACTOR VERSUS VOLTAGE GRADIENT FOR LIQUID NITROGEN AT 77°K (NOT BOILING) AND THREE PRESSURES

The dielectric constants of cryogenic liquids appear in Table 13, extracted from the work of R.B. Scott.⁷⁷

Published values of voltage breakdown in liquified helium, hydrogen, and nitrogen must be used with care because the values are sensitive to test conditions. Breakdown voltages measured by various investigations are shown in Table 14.

Details of the test conditions can be found in the cited references. An extensive literature survey and data summarization has been made by Gauster and Schwenterly.⁷⁸

Boiling of the liquified gases at or near the electrodes appears to have no effect on the breakdown voltage. Mathes⁷⁴ observed that when the temperature was dropped to freezing (14°K for H, 63°K for N) the breakdown voltage increased considerably (Table 14). Swan and Lewis⁸⁶ and T.J. Gallagher⁸⁷ showed that the dc dielectric strength of cryogenic liquids was influenced by the metals at the anode and the cathode. (Table 15).

TABLE 13
DIELECTRIC CONSTANT

Liquid	Temperature °K	Dielectric Const.
Helium	4.21	1.0469
	2.21	1.0563
	2.19	1.0563
	2.15	1.0565
	1.83	1.0562
Hydrogen	20.4	1.231
	14.0	1.259
Nitrogen	77.3	1.431
	63.1	1.467

TABLE 14
COMPARISON OF VOLTAGE BREAKDOWN OF CRYOGENIC LIQUIDS

Liquid	Data Source	Electrodes	Spacing (mm)	Temperature °K	Breakdown Strength kV/cm (peak)
He ⁴	Blaisse, Boogart, & Erne 79	5mm tungsten sphere to plane	0.05 to 0.15	4.2	720 dc
	Blank, & Edwards 80	3/8 in. steel spheres	0.15 to 0.5	4.2	1050 to 550 dc
N ₂	Goldschvartz, Steeg, Arts, & Blaisse 81	5mm tungsten sphere to plane	0.01 to 0.1 0.01 to 0.1	2.14 4.2	1600 to 900 dc 1300 to 850 dc
	Gerhold 82	25mm sphere to plane	0.1 to 0.5	4.2	700 to 530 dc
	Mathes 74	1/2 in. steel spheres	0.19 0.5 to 1.0	4.2 4.2	327 60Hz 319 to 294 60Hz
	Fallou, Galand, Bobo, & Dubois 83	15mm sphere to plane	0.1 to 7.5	4.2	700 to 150 50Hz
H	Fallou, & Bobo 74	-	5mm	4.2	566 0.02µs impulse
	Mathes 74	1/2 in. steel spheres 1/2 in. steel spheres	0.19 0.19	20 14	745 60Hz 1340 60Hz
N ₂	Swan & Lewis 84	5mm gold spheres 5mm Pt spheres	.02 to .1 .02 to .1	77.3 77.3	1500 dc 2240 dc
	Blaisse, Boogart, & Erne 79	5mm tungsten sphere to plane	.05 to .15	65	1600 dc
N ₂	Mathes 74	1/2 in. steel spheres 1/2 in. steel spheres	.19 .19	77.3 63	805 60Hz 1010 60Hz
	Fallou & Bobo 85	-	5mm 5mm	77.3 77.3	240 50Hz 660 .02µs impulse

TABLE 15

INFLUENCE OF ELECTRODES ON ELECTRIC STRENGTH OF CRYOGENIC LIQUIDS

Electrode	Argon	Oxygen	Nitrogen
Stainless Steel	1.40	2.38	1.88
Brass	1.01	1.44	1.62
Platinum	1.10	2.00	2.24

- 77) R. B. Scott, Cryogenic Engineering, New York: Van Nostrand, 1959.
- 78) W. F. Gauster and J. W. Schwenterly, "Dielectric Strength of Liquids and Gases at Cryogenic Temperatures - A Literature Survey," Appendix A in Cryogenic Dielectrics and Superconducting and Cryogenic Materials Technology for Power Transmission, Oak Ridge Nat. Lab. Rep., TM-4187, May 1973.
- 79) B. S. Blaisse, A. Van der Boagart and F. Erne, "The Electrical Breakdown in Liquid Helium and Liquid Nitrogen," Bull. Inst. die Froid, p. 330-340 (Annex 1958-1).
- 80) C. Blank and M. H. Edwards, "Dielectric Breakdown in Liquid Helium," Phys. Rev., Vol. 119, p. 50-52, July 1, 1960.
- 81) J. M. Goldschvartz, C. Van Steeg, A.F.M. Arts, and B. S. Blaisse, "Conf. Dielectric Liquids," p. 228, Dublin (1972).
- 82) J. Gerhold, "Cryogenics" 370, October 1972.
- 83) B. Fallou, J. Galand, J. Bobo, and A. Dubois, Bull. Int. Inst. du Froid, Annexe 1959-1, 377 (1969)
- 84) D. W. Swan and T. J. Lewis, Proc. Phys. Soc. 78, 448 (1961).
- 85) B. Fallou, and M. Bobo, "Electrical Properties of Insulating Materials at Cryogenic Temperatures," Conference on Electrical Insulation and Dielectric Phenomena, 1973 Annual Report, p. 514-523.

Polarity also influences DC voltage breakdown as seen in Table 14 for sphere-to-plane and point-to-plane electrode configurations. When the pressure of cryogenic liquids is increased, the voltage breakdown level also increases. Table 16 compares voltage breakdown for a three-fold change in pressure. Additional data has been developed by B. Fallou and M. Bobo⁸⁵, and M.J. Jefferies and K.N. Mathes.⁷⁶

TABLE 16
BREAKDOWN VOLTAGE, kV/mm VS PRESSURE (62.5mm SPHERICAL ELECTRODES
SPACED 1mm)

	1 Bar	3 Bars	Ratio - 3/1 Bars
Liquid He	18	24.5	1.36
Liquid H ₂	28	37.5	1.34
Liquid N ₂	29	44.5	1.53

3.6.3 Theory of Conductivity and Breakdown. The conductivity in cryogenic liquids between plane and spherical electrodes is so low that studying the motion of electrons and ions has not been feasible. Recently though, the conduction current has been artificially increased by using sharp pointed electrodes with radii in the order of 1000 Å^{88,89}. With this

- 86) D. W. Swan and T. J. Lewis, "Influence of Electrode Surface Conditions on the Electrical Strength of Liquified Gases," J. Electrochem Soc. 107, 180-185 (March 1960).
- 87) T. J. Gallagher, "Mobility Conduction, and Breakdown in Cryogenic Liquids: A review," Conference on Electrical Insulation and Dielectric Phenomena, 1973 Annual Report, p. 503-513.
- 88) B. Halbern and R. Gomer, "Journal Chem. Phys." Vol. 43, p. 1069, 1965
- 89) Y. Takahashi, "Electrical Corona in Liquid Nitrogen," Conference on Electrical Insulation and Dielectric Phenomena, 1974 Annual Report, p. 577-584.

"charge-injection" technique, the mobilities of electrons and ions can be studied. He II (superfluid) has a unique characteristic -- the mobility of the positive ion is always greater than that of the negative ion. A summary of the most recent work in this area has been presented by T. J. Gallagher.⁸⁷

Gas bubbles always accompany partial discharges. Y. Takahashi and others believe that the partial discharges are within the gas bubbles.⁸⁹ Using the bubble phenomena, D. Peier explains breakdown in liquid N₂ in terms of an avalanche of emulating bubbles.⁹⁰ The heat required for forming these gas bubbles might be supplied by electron-molecule collisions which do not lead to ionization. The increase in voltage breakdown with increasing pressure, shown in Table 16, supports this concept of partial discharges in bubbles. Three other theories are summarized and referenced by T.J. Gallagher.⁸⁷

3.6.4 Solid Insulators at Cryogenic Temperatures. Solid insulators at cryogenic temperatures show increased breakdown voltage. They do not experience short term degradation with corona, because of the cryogenic liquid environment. In selecting a solid insulation for low temperatures, consideration must be given to physical properties such as coefficient of thermal contraction, since the materials may crack or develop voids when cooled. Physical properties for many practical materials at cryogenic temperatures were compiled by A. Muller.⁹¹

The low -temperature dissipation factor for several materials is shown in Figure 39.⁸⁵ A. Muller⁹¹ and S.J. Rigby and B.M. Weedy⁹² provide a comprehensive list of suitable low-temperature plastics and their dissipation factors.

90) D. Peier, "Breakdown of Liquid Nitrogen in Point-Plane Electrodes," Conference on Electrical Insulation and Dielectric Phenomena, 1974 Annual Report, p. 567-576.

91) A. Muller, "Insulating Tape Characteristics at Cryogenic Temperature," Conference on Electrical Insulation and Dielectric Phenomena, 1973 Annual Report, p. 524-533.

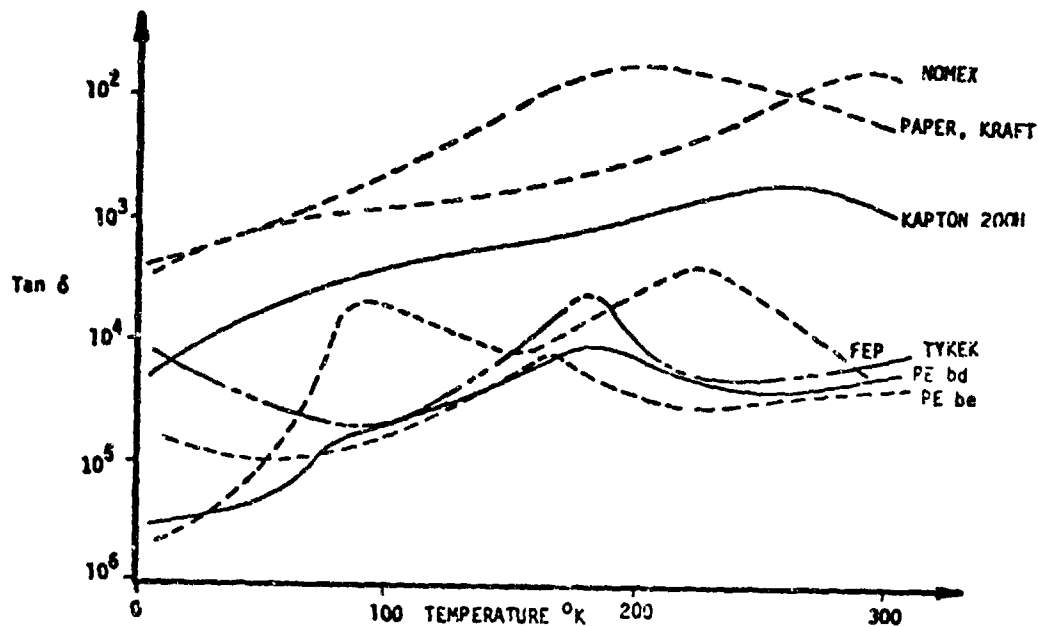

FIGURE 39. DISSIPATION FACTOR AT 1kHz AND UNDER 100 VOLTS

Data on the dielectric strength of solid insulators at cryogenic temperatures is incomplete and the measurements by different investigators often vary considerably. Almost all measurements have been made with films because tape wrapped films can be used to insulate high voltage power cables. Some of the published values appear in References 79, and 91 through 95.

- 92) S. J. Rigby and B. M. Weedy, "Liquid Nitrogen Impregnated Tape Insulation for Cryoresistive Cable," IEEE Transactions on Electrical Insulations, Vol. EI-10, No. 1, p. 1-9, March 1975.
- 93) Z. Iwata, and K. Kikuchi, "Electrical Insulation for Liquid Nitrogen Cooled EHV Cryogenic Cable," Conference on Electrical Insulation and Dielectric Phenomena, 1973 Annual Report, p. 494-502.
- 94) K. Haga, T. Kajima and Y. Fujuvira, "Development of a Liquid-Nitrogen Cooled Power Cable," Underground Transmission and Distribution Conference, 1974.

3.6.5 Vacuum at Cryogenic Temperatures. Vacuum insulation at cryogenic temperatures has been investigated.^{85, 96, 97, 98} Its main disadvantage is the need to support the conductor with insulators, greatly reducing the breakdown voltage of the combination. Most of the ionic activity preceding and during breakdown is at the triple junction between metal, dielectric, and vacuum, and along the dielectric surface.⁹⁶ P. Graneau and H.M. Schneider have measured breakdown voltage limits and tolerance to multiple electrical discharges. They used glass spacers to support the conductor in the vacuum.⁹⁸ To minimize damage from discharges the conductor support insulators must be made from inorganic materials such as glass, alumina, and porcelain.

Vacuum can also be used to enhance the dielectric strength of solid dielectric materials. Data obtained by M. Bobo and published by K.N. Mathes⁷⁵ is shown in Table 17.

TABLE 17
50 Hz VOLTAGE BREAKDOWN STRESS, MV/cm rms AT LIQUID HELIUM
TEMPERATURE, 4.2°K

	PET Film	FEP Film	Polyimide Film
In Boiling He	1.42	1.55	1.62
In Vacuum, 10 ⁻⁷ Torr	2.34	2.18	2.68
In Vacuum Varnished Electrodes	2.9	2.76	3.54

- 95) K. N. Mathes, "Cryogenic Cable Dielectrics," IEEE Transactions on Electrical Insulation, Vol. EI-4, No. 1, p. 2-7, March 1969.
- 96) J. Juchniewicz and A. Tyman, "Voltage Endurance Test of Vacuum Insulation for Cryo-Cables," IEEE Transactions on Electrical Insulation, Vol. EI-10, No. 4, p. 116-119, December 1975.
- 97) P. Graneau, "Lichtenberg Figures Produced by High Voltage Discharge in Vacuum," IEEE Transactions on Electrical Insulation, Vol. EI-8, No. 3, p. 87-92, September 1973.
- 98) P. Graneau and H. M. Schneider, "Vacuum Insulation for Cryo-Cable and its Resistance to Discharges," IEEE Transactions on Electrical Insulation, Vol. EI-9, No. 2, p. 63-68, June 1974.

3.6.6 Application Notes. The dielectric loss is important in high-voltage cryogenic equipment because these losses must be extracted out by refrigeration equipment. For AC cryoresistive cables, a rule of thumb is that the dissipation factor should not exceed 10^{-4} . For superconductivity AC cables it should be less than 10^{-5} (see Reference 73).

For long-term reliability, the insulation must be designed to operate below the corona inception voltage when system voltage is normal. Most materials do not degrade during short periods of partial discharge at cryogenic temperatures, because of the inert-liquid environment. We cannot have any bubbles if we are going to avoid partial discharges during normal operation, so the cryogenic liquid must be kept below its boiling point.

3.7 Voltage Stress for Several Electrode Configurations. Electrode configurations can be classified into three general categories: (1) points, which includes sharp corners, sharp bends in wire filaments, and projections from a surface, such as a solder draw; (2) curved surfaces such as long, spaced wires, a round wire close to a ground plane, corona balls, and a coaxial cable; and (3) parallel plates. Each of these electrode configurations has a unique electric field, depending upon the shape of the electrodes and the spacing between the electrodes. For configurations, such as plates, long parallel conductors and coaxial cylinders, the theoretical equations are well known and the field lines are easily drawn. Often the field is non-uniform, as in a transformer or generator winding. Then plotting the field requires much hand labor or access to a computer.

3.7.1 Electric Fields. The space between and surrounding two or more electrodes is regarded as the electric field. Every point within this space has a definite potential which is related to its physical position in the field. The negative gradient of voltage at any point is a vector which is defined as the electric field-strength E at that point. This gradient can be conceived as a force tending to displace a positive charge in the direction of the vector toward the negative electrode. Shown in Figure 40 is a field plot for an energized insulated conductor next to a ground plane. The field lines emanate perpendicularly from the negative electrode and terminate perpendicularly on the positive electrode. Only one field line crosses the gas-solid

dielectric interface at right angles -- the shortest one. At all other points along the interface the field lines cross at an angle.

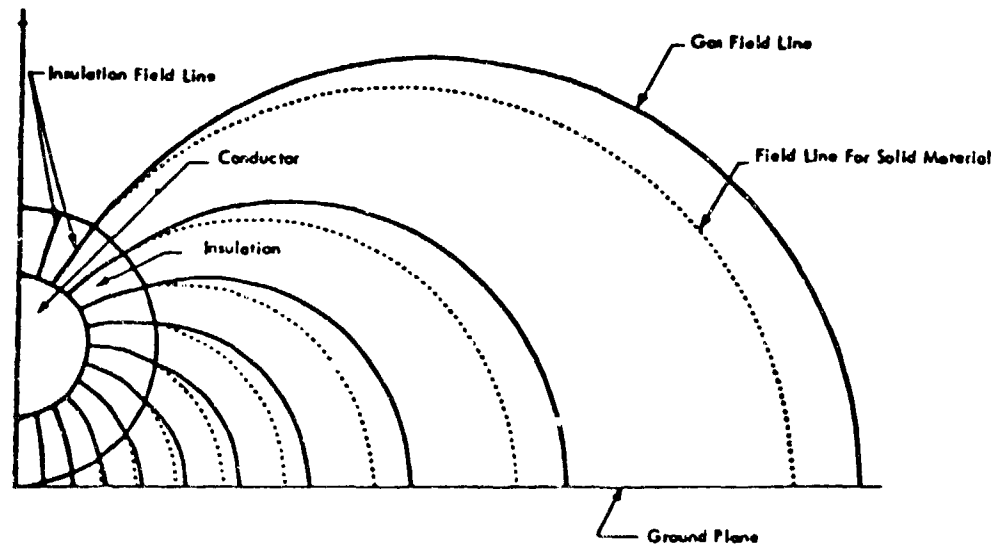

FIGURE 40. FIELD LINES BETWEEN A HIGH VOLTAGE CONDUCTOR AND GROUND

A treatise on electric field theory can be found in most texts on electricity and magnetism, or fields and waves. Von Hippel⁷, Greenfield⁸, and Schwaiger and Sorensen⁹⁹ have written texts on dielectrics which explain the basic principles of field theory. Texts describing field plotting and analysis are by Moore^{100, 101}, Bewley,¹⁰² Smythe,⁴ Stratton⁵, and Weber⁶.

- 99) A. Schwaiger and R. W. Sorensen, Theory of Dielectrics, John Wiley and Sons, Inc., New York, New York, 1932.
- 100) A. D. Moore, Fundamentals of Electric Design, McGraw-Hill Book Company, Inc., New York, New York, 1927.
- 101) A. D. Moore, "Mapping Techniques Applied to Fluid Mapper Patterns," Trans. AIEE, Vol. 71, 1952.
- 102) L. V. Bewley, Two-Dimensional Fields in Electric Engineering, The Macmillan Company, New York, New York, 1948.

3.7.2 Configurations. The best shape and spacing of electrodes in electrical/electronic equipment depends upon the physical construction of the equipment, the applied voltage, the type of insulation and gas pressure, and the operating temperature. For a given electrode spacing and at pressure times spacing values greater than $1500 \text{ N/m}^2\text{-cm}$, a spark will jump between small-radius electrodes at lower voltage than between electrodes having large radii (Figure 41). This indicates that for a given potential difference and spacing the peak field intensity at the electrodes is smallest when the field is homogeneous (parallel plates) and the field lines are thus parallel. Most parallel plates must have edges where the field is more intense than in the center. By rounding the edges properly, this field can be spread over a greater area, reducing the electric field gradient at the electrode (Rogowski¹⁰³).

For electrodes of any given shape the variation in potential, as a function of the distance from one electrode to the other electrode, can be calculated by solving the differential equations for the electrostatic field. For parallel plates, concentric spheres, and coaxial cylinders the equations for the field strength are:⁹⁹

Parallel Plates

$$E_x = \frac{\partial \phi}{\partial x} = -A = \frac{V}{S} \text{ volts/cm} \quad (3-26)$$

where: E_x = voltage gradient at distance x between electrodes volts/cm
 ϕ = potential at the electrode, volts
 x = distance from the reference electrode, cm
 A = constant
 V = volts
 S = spacing between electrodes, cm

103) W. Rogowski and H. Rengier, Arch. Elektrotech., 26, 1926, Page 73.

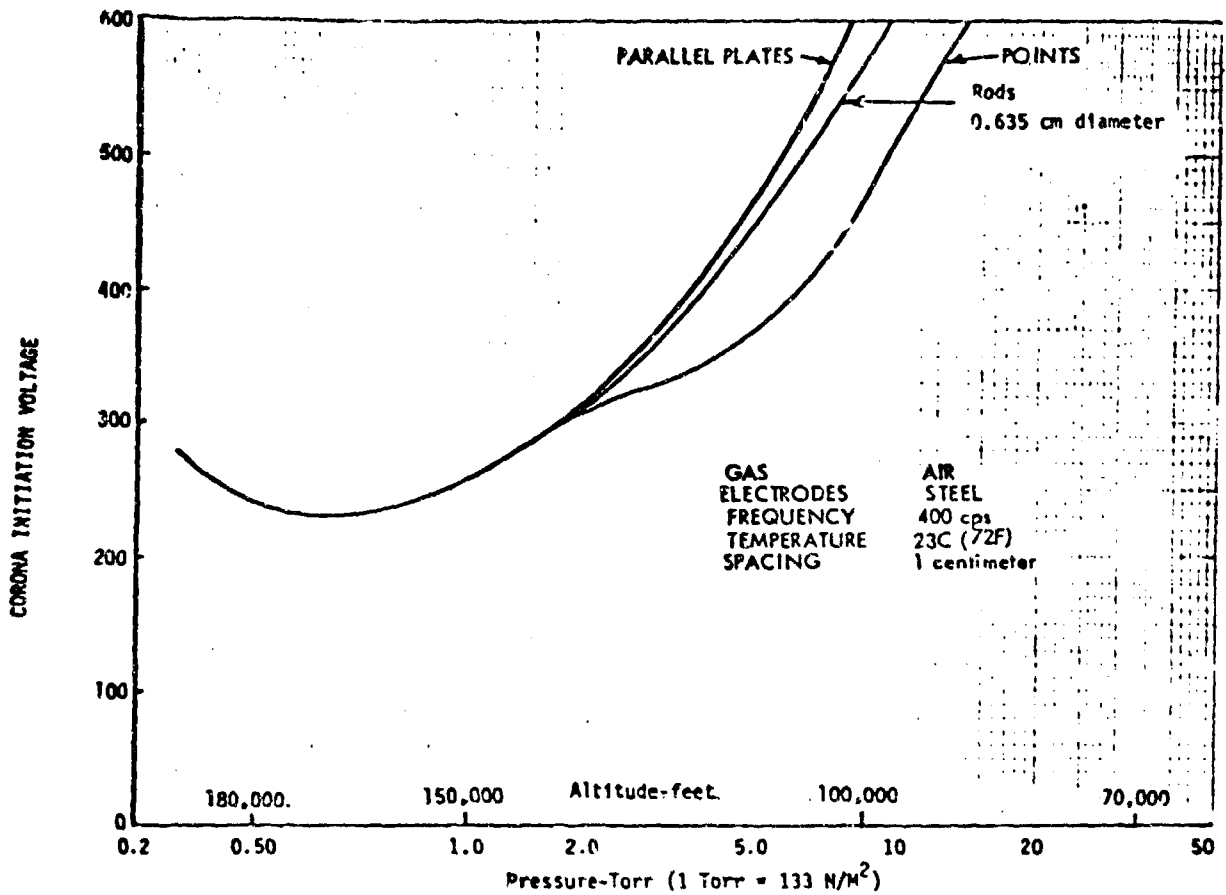

FIGURE 41. CORONA INITIATION VOLTAGE BETWEEN POINTS, RODS, AND PLATES

Concentric Spheres

$$E_x = \frac{V}{x^2} \frac{r_1 r_2}{r_2 - r_1} \quad (3-27)$$

where: $|V_2| > |V_1|$

r_1 = inner sphere (outside) radius, cm

r_2 = outer sphere (inside) radius, cm

V_1 = reference voltage, volts

V_2 = high voltage applied to opposite electrode, volts

The maximum field gradient E_m is at the surface of the smaller sphere where $X = V_1$ is:

$$E_m = \frac{V}{s} \frac{r_2}{r_1} \quad (3-28)$$

Coaxial Cylinders

$$E_m = \frac{V}{r_1 \ln\left(\frac{r_2}{r_1}\right)} \quad (3-29)$$

where: r_1 = inner-conductor outside radius, cm
 r_2 = outer-conductor inside radius, cm
 E_m = maximum field gradient at the inner conductor surface, V/cm.

Field gradient equations for more complicated electrode configurations are too complex for ordinary design application. Two examples of rigorous solutions for complicated electrodes illustrate the point:

Sphere gap (Reference 99, page 89)

The field gradient along the x-axis between two equal/unequal diameter spheres with equal/unequal charge is given below.

$$E_m = \frac{V}{2r(1-x)} \sum_{n=0}^{\infty} x^n \left[\frac{1-x^{2n+1}}{(1+x^{2n+1})^2} \right] \quad (3-30)$$

or:

$$E_m = \frac{V}{2r} \left[1 + \frac{(1+x)^3}{1-x} \left[x \frac{1-x^3}{(1+x^3)^2} + x^2 \left(\frac{1-x^5}{(1+x^5)^2} \right) + x^3 \left(\frac{1-x^7}{(1+x^7)^2} \right) + \dots \right] \right] \quad (3-31)$$

where: r = radius of the sphere, cm
 x = distance from center of the sphere to the point between the spheres, cm

Parallel Cylinders (Reference 102, page 45)

$$E_m = \frac{V}{2r} \left(\frac{1}{\cosh^{-1}\left(\frac{s/2}{r}\right)} \right) \quad (3-32)$$

More difficult field patterns can be rigorously calculated using the techniques of References 4, 5, 6, 99, and 102.

3.7.3 Empirical Field Equations. An empirical field equation or formula is the shortened, simplified form of a rigorous equation. Rigorous equations, manageable with electronic calculators, are still difficult to use in everyday design work; especially if the design has to be assembled piece-wise. Often the equation for the exact required electrode shape is not readily available to the designer. To derive or compute a rigorous equation is an unnecessarily costly and time-consuming process, so it is usually more advantageous to use time-proven empirical equations. Furthermore, the maximum stress is often the only value needed in a design, and the plotting of the complete field using a rigorous equation is not necessary. Empirical equations for the maximum field stresses at the smaller electrodes, for several electrode configurations are given in Table 18.¹⁰⁴ Electrical stresses calculated with these equations are within 10% of values obtained with rigorous equations.

Published empirical equations for sparkover gradients in air and sulfur hexafluoride appear in Tables 2 and 3.¹⁰⁵ The "typical error" in Table 3 represents the difference between the calculated values and experimental results, except for equations (8) and (9) in Table 3. Here the values represent differences between the rigorous and empirical equations.

The electrode geometries used in Tables 2 and 3 are shown in Figure 42. Parameters for the equations in Tables 2 and 3 are as follows:











E_s = Sparkover gradient, kV/mm

g = Gap length, mm

- 104) A. Bowers and P. G. Cath, "The Maximum Electrical Field Strength for Several Simple Electrode Configurations," Philips Technical Review, 6, 1941, p. 270.
- 105) J. M. Mattingley and H. M. Ryan, "Correlation of Breakdown Gradients in Compressed Air and SF₆ for Nonuniform Fields," Conference on Electrical Insulation and Dielectric Phenomena, National Academy of Sciences, Washington, D. C., 1973, pp. 222-233.

TABLE 18

MAXIMUM FIELD STRENGTH E WITH A POTENTIAL DIFFERENCE V BETWEEN THE ELECTRODES, FOR DIFFERENT ELECTRODE CONFIGURATIONS

Configuration		Formula for E
Two parallel plane plates		$\frac{V}{a}$
Two concentric spheres		$\frac{V}{a} \cdot \frac{r+a}{r}$
Sphere and plane plate		$0.9 \frac{V}{a} \cdot \frac{r+a}{r}$
Two spheres at a distance a from each other.		$0.9 \frac{V}{a} \cdot \frac{r+a/2}{r}$
Two coaxial cylinders		$\frac{V}{2.3 r \lg \frac{r+a}{r}}$
Cylinder parallel to plane plate		$0.9 \frac{V}{2.3 r \lg \frac{r+a}{r}}$
Two parallel cylinders		$0.9 \frac{V/2}{2.3 r \lg \frac{r+a/2}{r}}$
Two perpendicular cylinders		$0.9 \frac{V/2}{2.3 r \lg \frac{r+a/2}{r}}$
Hemisphere on one of two parallel plane plates.		$\frac{3V}{a}; (a \gg r)$
Semicylinder on one of two parallel plane plates.		$\frac{2V}{a}; (a \gg r)$
Two dielectrics between plane plates (ϵ_1, ϵ_2)		$\frac{V \epsilon_1}{a_1 \epsilon_2 + a_2 \epsilon_1}$

kV = Applied voltage

r_1 = radius of smaller electrode, mm

r_2 = radius of second or larger electrode, mm

s = spacing, center of r_2 to center of r_1 , mm

p = pressure, N/m²

3.7.4 Utilization Factor. The utilization or efficiency factor is defined as the ratio of the field stress between parallel plates and the maximum field stress at the smaller electrode of a non-uniform configuration with identical spacing non-parallel plate electrodes. The utilization factor is numerically equal to the required voltage de-rating. In equation form:

$$n = \frac{E}{E_m} < 1 \quad (3-33)$$

where: n = utilization factor

E = voltage stress between parallel plates spaced a unit apart, kV/mm

E_m = maximum voltage stress between two conductors - spaced a unit apart, kV/mm

a = spacing, mm

Plots of the utilization factors as a function of electrode spacing for several electrode geometrics are shown in Figure 42. These geometrics are commonly used in many electrical/electronic designs. The utilization factor, which provides a way of quickly estimating the sparkover or breakdown voltage of a configuration, can also be used for estimating the minimum electrode radius for a given spacing when the electrical stress capability of the dielectric is known.

3.7.5 Freehand Field Plotting. For complicated fields, which are very difficult to analyze mathematically, even with computer, freehand flux plotting by the trial and error method is a recourse. Sufficient accuracy may be obtained for most practical engineering problems by plotting the field with "curvilinear" squares. Freehand field plotting techniques are described in Appendix A.

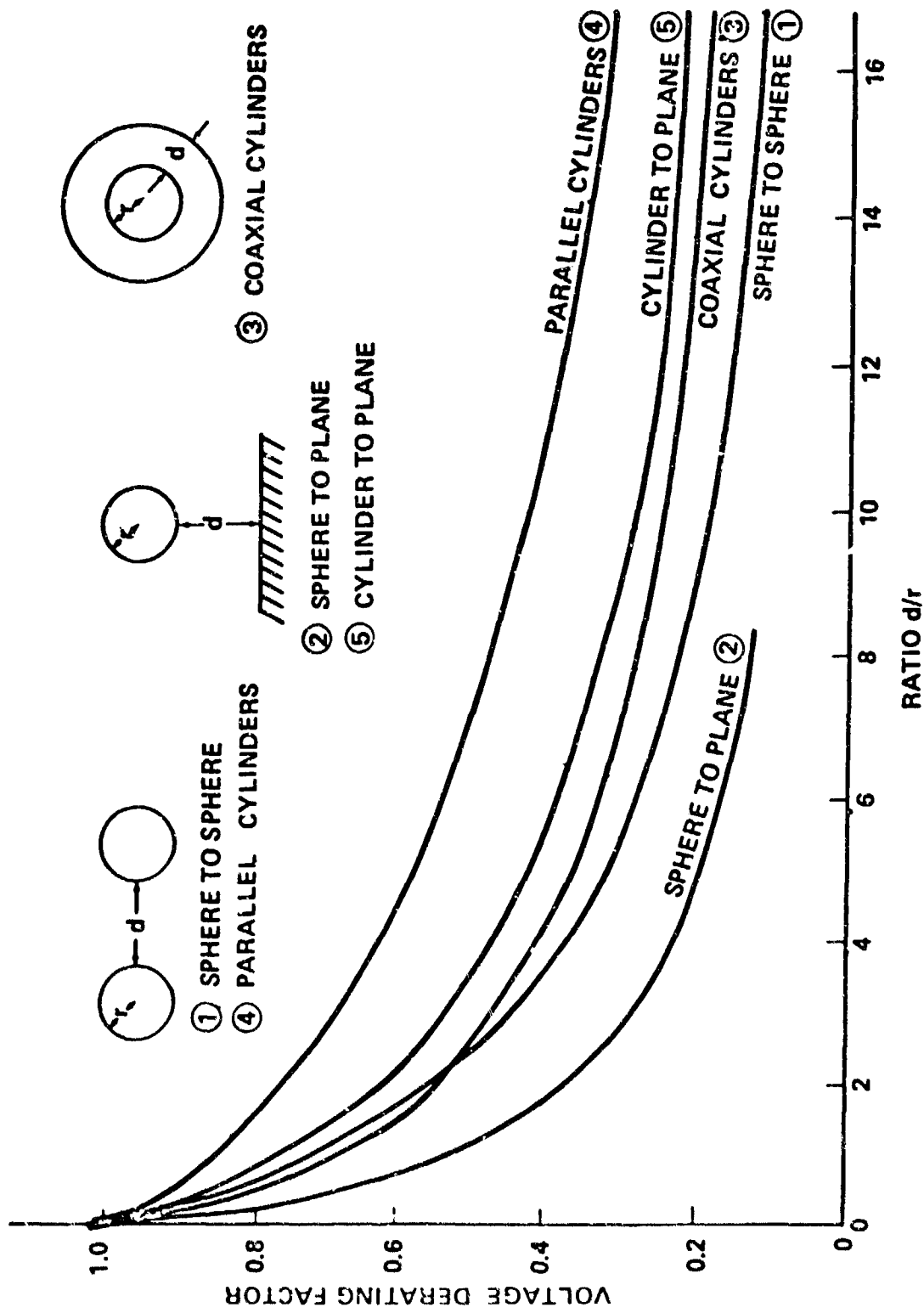

FIGURE 42. UTILIZATION FACTOR FOR VARIOUS ELECTRODE CONFIGURATIONS

3.7.6 Mathematical Mapping Techniques. include:

- o Analytic Solutions
- o Conformal Mapping Techniques
- o Finite-difference Computer Programs
- o Resistance - Network Analogs
- o Conducting - Paper Analogs

For the electronic field problems encountered in the dielectric design of transformers and electric machines the resistance paper analog gives quick, reliable results and is preferred by many designers. Its versatility makes it easy for the designer to quickly prepare a field plot and directly interpret the results (see Appendix A).

4. EQUIPMENT

The principal function of electrical insulation in equipment is to isolate the conductors from each other and their surroundings, restricting current flow to the isolated conductors. This same insulation must support the conductors and transfer heat away from them. High power, high voltage airborne equipment is densely packaged, so materials with high dielectric strength are required.

4.1 Wiring and Connectors. Partial discharges in the electrical wiring generate noise which is conducted to connected equipment. Typically, the noise signature is between 20 KHz and 20 MHz. If the partial discharges are extensive, noise can also be induced in low-level neighboring circuits. In high frequency systems, as in radar, the wave shapes of the electrical signals can have partial discharges. These partial discharges produce ozone, light, acid, and the deterioration of dielectrics. If corona persists over 100 hours, the dielectric may start to deteriorate and eventually a breakdown will result.

4.1.1 Design Considerations. Voltage, frequency, temperature, ambient gas composition, pressure, radiation, and structural requirements must be known when designing insulation for high-voltage equipment. This includes the steady-state operating voltage and also any higher voltage transients, their duration, and their frequency of repetition.

Air Pressure. The pressure of air between electrodes in the electrostatic field is a parameter in determining location of the minimum zones on the Paschen law curve. This air pressure between electrodes may differ from the surrounding ambient air pressure and it may have transients. With higher temperatures and mechanical stress, air trapped in the insulation layers may rupture or force voids in the insulation when the surrounding air pressure is reduced. Figure 43 and Figure 44 show such voids created by air trapped between the center conductor, and in the outer shield.

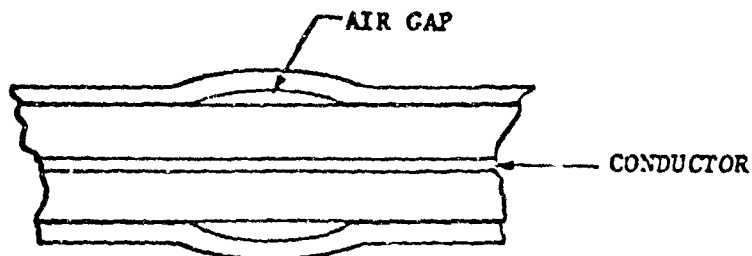

FIGURE 43. OUTER JACKET RUPTURE

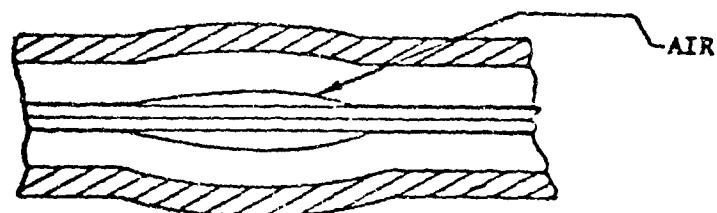

FIGURE 44. CENTER CONDUCTOR DELAMINATION

Temperature. Since each electrical insulation has maximum temperature limits and temperature-life limits, the short-time and continuous temperature, both ambient and local, must be known.

Gases. If the gas between electrodes in the electrostatic field is other than air, Paschen law curves must be determined for that gas.

Environmental conditions. Other environmental factors affecting insulation are ultra-violet and nuclear radiation, and exposure to solvents and chemicals.

Mechanical requirements. Requirements to be satisfied include shock, abrasion, stability, strength, and flexure from vibration.

Frequency. Most of the published aerospace partial discharge initiation voltage data are in terms of 400 Hz, rather than direct current. A formula for comparing dc data with 400 Hz ac data is $V_{ac} = 0.707 V_{dc}$. The direct current initiation voltage for point-to-plane electrode configurations is affected by the polarity of the point, the configuration with the point negative breaking down at a lower voltage. The ac initiation voltage always corresponds to the dc polarity that has the lower voltage.

At high frequencies, the interference generated by partial discharges is worse than at low frequencies. The rate of deterioration of an insulation by partial discharges is usually proportional to frequency. The dielectric strength of insulators is inversely proportional to frequency. Typical loss of dielectric strength with frequency is shown in Table 19 for polyethylene and Table 20 for teflon.

TABLE 19
POLYETHYLENE--DIELECTRIC STRENGTH, V/mil, FOR 30-MIL SHEETS AS FUNCTIONS OF TEMPERATURE AND FREQUENCY*

<u>Temp., °C</u>	F R E Q U E N C Y						
	<u>60 Hz</u>	<u>1 kHz</u>	<u>38 kHz</u>	<u>180 kHz</u>	<u>2 MHz</u>	<u>18 MHz</u>	<u>100 MHz</u>
-55	1,660	1,270	750	700	410	190	160
25	1,300	970	500	460	340	180	130
50	1,140	910	590	580	280	150	150
80	980	970	440	430	220	150	150

TABLE 20
TEFLON--DIELECTRIC STRENGTH, V/mil, FOR 30-MIL SHEET AS FUNCTION OF TEMPERATURE AND FREQUENCY*

<u>Temp., °C</u>	F R E Q U E N C Y						
	<u>60 Hz</u>	<u>1 kHz</u>	<u>38 kHz</u>	<u>180 kHz</u>	<u>2 MHz</u>	<u>18 MHz</u>	<u>100 MHz</u>
-55	1,080	940	660	600	400	240	160
25	850	810	540	500	380	210	140
50	800	770	530	500	360	210	140
85	780	670	530	480	360	220	140
125	870	630	560	520	350	220	140

4.1.2 High Voltage Cable. At high voltages, special precautions must be taken to eliminate air voids and air gaps from the electrostatic field between conductors. High voltage wire is constructed with conducting layers around the stranded center conductor and just within the outer conductor braid, as shown in Fig. 45. In this construction, the air trapped within the stranded center conductor is not electrically stressed and does not have to be eliminated. The insulation can be advantageously made of several layers, with the dielectric constant (ϵ) of each layer being successively higher toward the center. The voltage gradient can then be maintained nearly constant from the inner conducting layer to the outer conducting layer, rather than being much higher near the inner conducting layer (Fig. 46). Equations 4-1 through 4-8 are used to compute the dielectric constants or layer thicknesses needed.

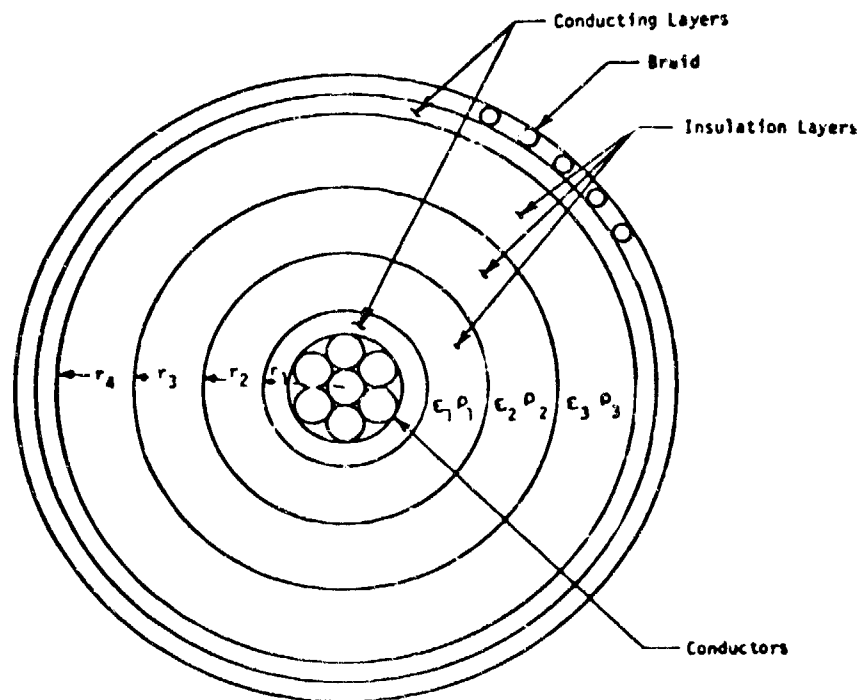

FIGURE 45. HIGH VOLTAGE WIRE

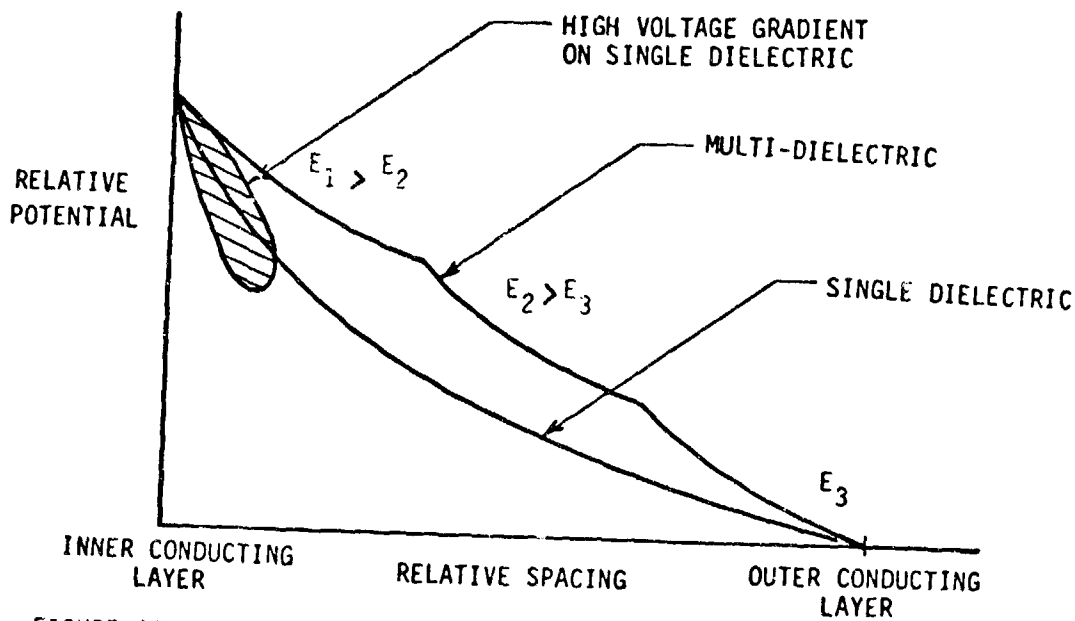

FIGURE 46. FIELD GRADIENT FOR SINGLE AND MULTIPLE LAYER DIELECTRIC

In a coaxial configuration having three layers of insulation (Fig. 45), the voltage stress is not constant across any layer of insulation. In the inner insulation, $\epsilon_1 \rho_1$, the stress (E_1) adjacent to the conductor is in volts per unit of distance

$$E_1 = \frac{V_1}{r_1 \ln(r_2/r_1)} \quad (4-1)$$

The symbols are defined in Fig. 45. The stress within the outer surface of the inner insulation is

$$E_1 = \frac{V_1}{r_2 \ln(r_2/r_1)} \quad (4-2)$$

At the same time, the stress in the $\epsilon_2 \rho_2$ insulation just outside of the interface from insulation ($\epsilon_1 \rho_1$) is

$$E = \frac{\epsilon_1}{\epsilon_2} \left(\frac{V_1}{r_2 \ln(r_2/r_1)} \right) \quad (4-3)$$

Continuing in this manner through insulation layer $\epsilon_3 \rho_3$, we can derive an expression for the voltage at the outer surface of the inner layer of insulation.

$$V_0 = \frac{V_1 \epsilon_1}{\ln (r_2/r_1)} \left[\frac{\ln (r_2/r_1)}{\epsilon_1} + \frac{\ln (r_3/r_2)}{\epsilon_2} + \frac{\ln (r_4/r_3)}{\epsilon_3} \right] \quad (4-4)$$

The other interface voltages can be similarly calculated.

The voltage stress and total allowable voltage when dc is applied to the coaxial configuration in Fig. 45 can be calculated in a similar manner. The stress at the conductor is given by

$$E_1 = \left[\frac{V_1}{\ln (r_2/r_1)} \right] \frac{1}{r_1} \quad (4-5)$$

The stress at the interface between insulation ($\epsilon_1 \rho_1$) and ($\epsilon_2 \rho_2$) changes as one crosses the interface. In insulation ($\epsilon_1 \rho_1$), the stress is

$$E'_1 = \left[\frac{V_1}{\ln (r_2/r_1)} \right] \frac{1}{r_2} \quad (4-6)$$

while in insulation ($\epsilon_2 \rho_2$), the stress is

$$E'_2 = \left[\frac{V_2}{\ln (r_3/r_2)} \right] \frac{1}{r_2} = \left[\frac{V_1}{\ln (r_2/r_1)} \right] \frac{1}{r_2} \left[\frac{\ln (r_3/r_2)}{\ln (r_2/r_1)} \right] \frac{\rho_2}{\rho_1} \quad (4-7)$$

and finally

$$V_0 = V_1 \left[\frac{\rho_1 \ln (r_2/r_1) + \rho_2 \ln (r_3/r_2) + \rho_3 \ln (r_4/r_3)}{\rho_1 \ln (r_2/r_1)} \right] \quad (4-8)$$

4.1.3 High Voltage Connectors. Connectors must also be designed to eliminate air voids between conducting surfaces. One successful method is to make one side of the mating-interface from soft pliable insulation (Fig. 47). When mated, the pliable insulation conforms closely to the opposite dielectric. The pliable insulation should first contact the molded insulation near the center conductor, then the contact should progress out to the shell, without trapping air space.

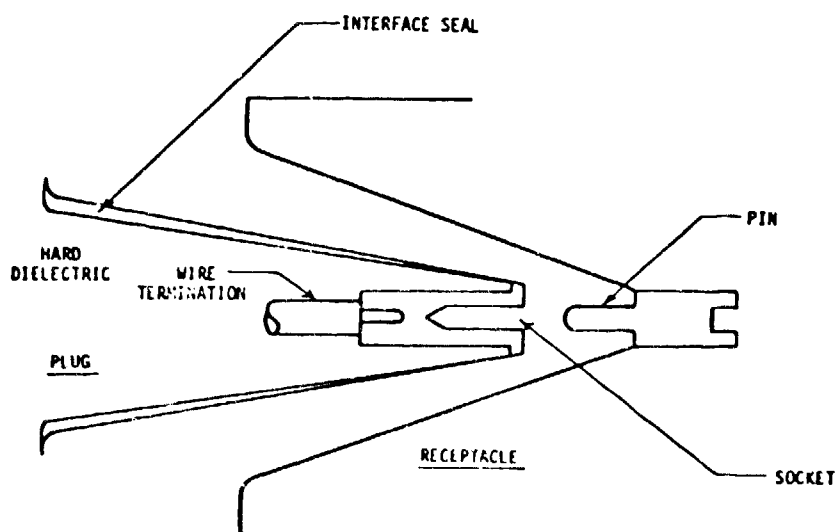

FIGURE 47. HIGH VOLTAGE CONNECTOR

A thin layer of silicon grease has been applied to the insulation surfaces of some connectors to fill micropores in the insulation. Too much grease (more than 5 mils) has a tendency to prevent complete closure of the connector, introduce air cavities, or deform the pliable insulation. Therefore, silicone or other additives are not recommended for properly constructed high-voltage connectors. A properly constructed connector has complete mating on all insulated surfaces of the plug and receptacle.

4.2 Capacitors. High voltage capacitors include voltage ratings of over 2000V or 1000V rms. This threshold is strictly arbitrary and is based on the observation that above these voltage ratings it is usually advisable to connect capacitance elements in series rather than to use a single dielectric pad to withstand the total voltage.

Dielectrics used for high voltage include liquid impregnated paper, plastic film, paper-plastic combinations, mica, ceramics, glass, compressed gas, and vacuum. Unless special requirements with respect to temperature, stability, radiation resistance, or packaging are involved, liquid impregnated paper or plastic offer the best energy-space-cost combination and consequently are more widely available.

This section deals only with high voltage capacitors. Many dielectric configurations which are quite appropriate for low voltage, high performance capacitors for solid-state communication equipment are not applicable to high voltage work, and are not covered here. This excluded category includes electrolytic and ceramic-insulators capacitor types.

Design Features. Design features are strongly influenced by the intended application. The most important design feature of capacitors is the use of the lowest dissipation factor consistent with the dielectric stress that yields an acceptable failure rate. DC capacitors for continuous duty also require low dissipation factor since some AC ripple is usually present. High insulation resistance is also usually required for applications. DC energy storage capacitors require design features that permit extremely high currents as well as very fast charge and discharge rates.

4.2.1 Construction and Processing. Construction and processing have a major effect on high-voltage capacitors performance. Series connection of sections necessitates careful attention to conductor insulation, clearances, geometry, and workmanship while the necessity for liquid impregnation requires meticulous control of materials purity, initially as well as prevention of contamination during processing.

4.2.2 Dielectrics. Liquid impregnation is the most effective means of assuring corona-free performance at rated voltage. All papers and films have surface irregularities that trap air when they are stacked between metal electrodes. Unless the air is replaced by a liquid with dielectric constant reasonably close to that of the paper or film, the stress distribution under an applied potential will be such that the highest stress will appear across the air pockets. Since the air has a dielectric strength far lower than the paper, film or liquid, it will ionize and initiate partial discharges at a potential much lower than that required if no air were present. Under dc-voltage stress, the mechanism is similar except that the stress distribution is controlled by the resistivity of the dielectric materials rather than by their dielectric constants. Another advantage of liquid impregnation is that air, with a dielectric constant of 1.0, is replaced by oils or askarels with dielectric constants of more than five, resulting in a more compact capacitor.

Impregnation with solids such as waxes or resins is feasible for applications but has not been found to be reliable for operation at voltages above 225 volts rms because of susceptibility to partial discharge damage. Unimpregnated plastic film capacitors are also suitable for applications but are subject to partial discharge damage at ac voltage above 225 volts rms unless special design features are provided.

4.2.3 Essential Design Features. In addition to the requirements listed below, all types of high-voltage capacitors must be made from dielectric materials having the highest available dielectric strength and having the longest demonstrated life at rated stress.

Capacitor Requirements

<u>AC Capacitors</u>	<u>DC Capacitors</u>	<u>Energy Storage Capacitors</u>
Low dissipation factor	Low dissipation factor	Low equivalent series resistance (ESR)
High partial discharge threshold	Low insulation resistance	Low insulation resistance
		High current capacity
		Low inductance

4.2.4 Failure Modes and Mechanisms. Failure modes in capacitors include short circuits, open circuits, and parameter drift, of which shorts are by far the most frequent. Shorts may result from one of many mechanisms, the most common being electrical breakdown caused by conducting sites or electrically weak areas in the dielectric. Conducting sites may be particles imbedded in the paper, airborne particles picked up during assembly, foil slivers, or products generated by partial discharge. Weak areas may result from torn paper, thin spots, or dielectric layers missed during assembly.

Even a moderate sized capacitor has many square centimeters of dielectric which has to be ultra thin to achieve reasonably small volume. Consequently stresses in capacitor dielectrics are usually far higher than in dielectrics used in other insulation applications. Measures to assure the highest possible electrical strength and longest life of capacitor dielectrics include multi-layer pads, liquid impregnation, use of series connections for voltage ratings above about 2500 volts, assembly in a controlled environment, high potential testing and, in some cases, burn-in at elevated voltage and temperature.

Even the best dielectric papers contain a finite number of conducting particles of randomly distributed sizes, randomly located in position. Multi-layer construction has least chance of having a conducting particle completely bridge the foil electrodes. Since the thinnest paper contains the most conducting particles (full thickness of paper) per square foot, it is desirable to use the thickest paper possible to keep the number of particles low. However, the thinnest possible paper gives the highest capacity per unit volume. A compromise is therefore necessary.

The dielectric strength of a paper pad increases with the number of layers up to four or five layers. Above this number the increase in strength is no longer proportional to the increase in number of layers. There is also an apparent decrease in electrical strength per unit thickness with individual paper thicknesses greater than 0.75 mils. This appears to be an effect of voltage gradient across the dielectric. It therefore becomes advisable to assemble the capacitor by connecting sections in series rather than using thicker pads.

Plastic films such as polyethylene terephthalate (MYLAR) are able to withstand stresses as high as impregnated paper can but the resulting capacitors are generally larger and more expensive for the same performance. Liquid impregnated paper-polypropylene sandwich dielectrics are competitive with liquid impregnated paper but not as widely used because there are fewer reliable sources of supply.

Parameter drift and open circuits are not commonly encountered failure modes in high voltage capacitors, but there have been instances where inexperienced manufacturers have tried to connect to the aluminum foil electrodes by pressure contact rather than by soldering or welding. This is always disastrous because aluminum oxidizes generating open circuits under low voltage stress and destructive arcing under ac.

With liquid-impregnated capacitors the container terminations and seals are important. All free space must be filled with liquid to preclude gas that can ionize. Rectangular or oval cases are designed with enough flexibility to permit the liquid to expand and contract as temperature and pressure change. Cylindrical or rigid walled cases must be designed with provisions that prevent low pressure gas accumulation between plates.

4.2.5 Effects of Partial Discharges. The life of an insulating material depends upon its type, the operating temperature, voltage stress, applied voltage, physical dimensions, materials control during manufacture, and cleanliness. Also important are small defects in the layers of conducting foil and insulation which may become gas-filled voids. Partial discharges can be generated when the gas is overstressed. These discharges are accompanied by electron bombardment which generates hot spots and acts on the air to produce ozone and nitrous oxides that decompose surrounding materials. Damage to the electrical insulation by electron bombardment and chemical deterioration can be identified by a decrease in insulation resistance and an increase in the dissipation factor. Dielectric materials are often evaluated with breakdown tests, superior materials being expected to exhibit higher breakdown voltages. A breakdown test is useful in finding flaws in the insulation. However, where a solid dielectric is to be impregnated with a liquid or when air voids may be present, the value of a breakdown test may be limited because

breakdown values are usually considerably higher than the voltage at which the insulation is used. This point is illustrated in Fig. 48 which shows the relative breakdown values, where partial discharges start and the range of the useful electrical stresses.

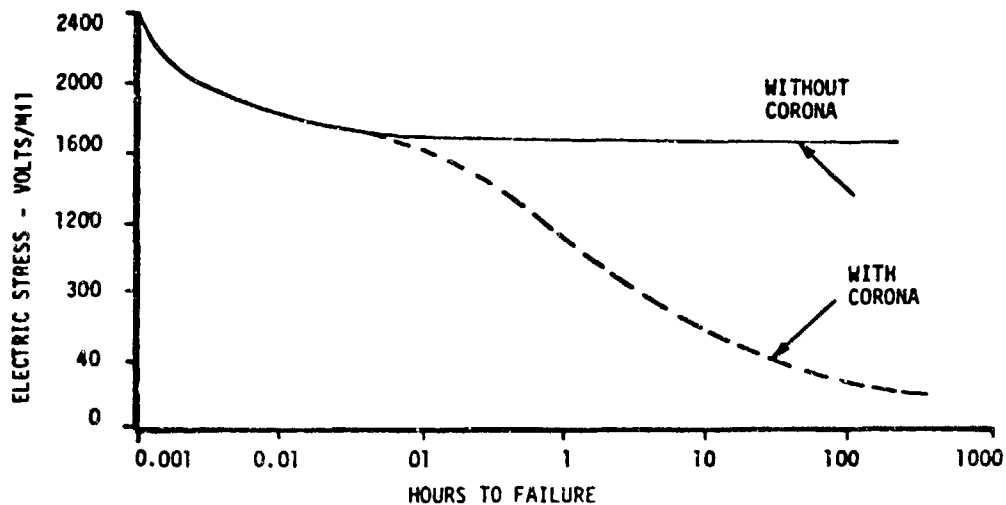

FIGURE 48. DIELECTRIC LIFE OF POLYETHYLENE WITH & WITHOUT CORONA

The discharge inception voltage is very important because a capacitor, if permitted to operate with internal partial discharges, will soon fail as shown in Fig. 48, for polyethelene insulation. Other insulation materials will degrade similarly.

Impregnated paper. As impregnating dielectric liquids age, their molecules polymerize. High temperature and electrical stress accelerate polymerization. In time, continued electron bombardment will carbonize the polymerized molecules and voltage breakdown or puncture of the insulation results.

Gas voids. The partial discharge initiation voltage for gas-filled voids is much lower for solid and impregnated paper dielectrics. Gas-filled voids result from incomplete impregnation during manufacture and must be

detected and eliminated. Dry unimpregnated areas in the insulating paper contain minute voids. Gas-filled voids may also be found at the ends of the individual layers of insulating paper. Also small wrinkles may be formed in the capacitor foil during manufacture. If these small wrinkles are not completely impregnated or filled with solid or liquid insulation, gas-filled voids will be present.

The temperature of the partial discharge across the center of a gas-filled void could be as high as $4,000^{\circ}\text{K}$.¹⁰⁶ The gas itself will be much cooler than the discharge channel, around 550°C . The partial discharge inception voltage (PDIV) across a gas-filled void can be as low as 230 volts rms, at the Paschen-law minimum. After gases such as hydrogen or a hydrocarbon gas evolves the PDIV can decrease to 185 to 200 volts, depending upon the breakdown characteristics of the gas or gases and thickness of the series dielectric.

4.2.6 Failure Rate Prediction. Capacitor life is, as expected, dependent on voltage stress and temperature. The relationship can best be described by a failure rate expressed as the percentage of failures (per 1000 unit-hours) based on a specific confidence level. In continuous operation at rated voltage capacitors exhibit a relatively high initial failure rate, called infant mortality, lasting a few hour decades. This is followed by years of essentially constant or slightly decreasing failure rate and finally a rapidly increasing failure rate as wearout become predominant. This is illustrated by the classical "bathtub" shaped curve (Fig. 49).

It is feasible to relate life or long time breakdown to commonly used values of dielectric strength. Dielectric strength is measured on small specimens during a "life" on the order of 60 seconds, whereas end-of-life breakdown levels of a large specimen such as a capacitor are subject to an area effect as well as long term chemical and physical changes.

106. J.M. Meek and J.D. Craggs, Electrical Breakdown of gases, Oxford at the Clarendon Press, London, England, 1953, pp 415-421.

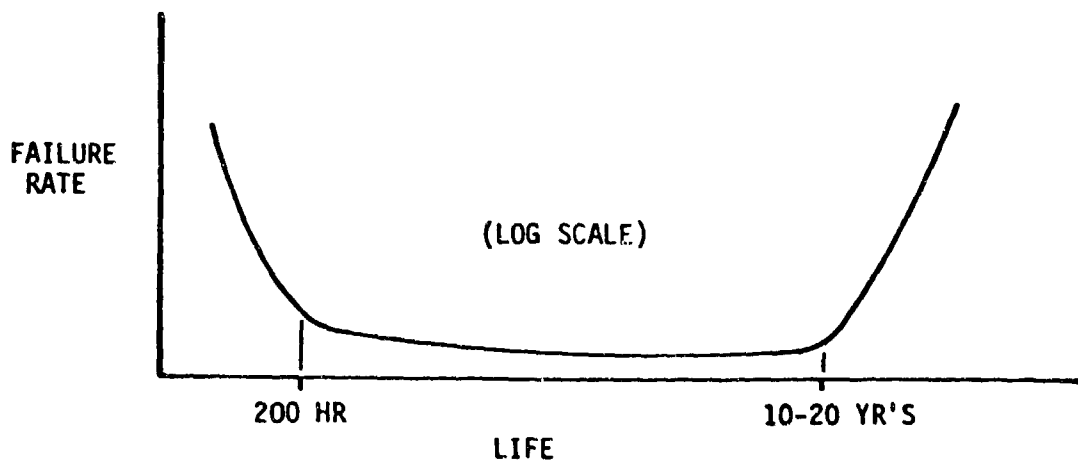

FIGURE 49. FAILURE RATE OF CAPACITORS

Voltage ratings of capacitors are based on life tests using many samples at many voltages and temperatures. Short-time overvoltage tests during manufacturing stages screen out grossly defective parts, but cannot be depended on to reject marginal parts. A burn-in at elevated voltage and temperature is effective in reducing infant mortality of capacitors when reliability is more important than cost. Burn-in is not customarily performed on non-military capacitors. Failure rate data is the basis of reliability-level predictions for established reliability parts, which are then derated to achieve a specific level of reliability. Acceleration factors have been estimated for most types of capacitors, but are not readily available for high voltage capacitors since very few high voltage capacitors are built to military specifications.

The relationship of failure rate to voltage and temperature can be expressed as:

$$\lambda_{\mu} = \lambda_r K^{(T_u - T_r)} \left(\frac{V_u}{V_r}\right)^n \quad (4-9)$$

Where:

λ_{μ} = failure rate at use conditions

λ_r = failure rate at rated conditions

k = temperature acceleration constant
 T_u = use temperature ($^{\circ}\text{C}$)
 T_r = rated temperature ($^{\circ}\text{C}$)
 V_u = use voltage
 V_r = rated voltage
 n = voltage acceleration factor

The following are values of constants k and n for some common dielectrics:

<u>Dielectric</u>	<u>k</u>		<u>n</u>	
	<u>DC</u>	<u>AC</u>	<u>DC</u>	<u>AC</u>
Mineral oil-paper	1.07	1.036	5	5
Askarel-Paper	-	1.09	5	5.6
MYLAR	1.07	-	5-7	-

Published data relating voltage to dielectric thickness for a given life-time are always based on some specified active area of dielectric. This voltage must be derated by a factor which depends upon the ratios of the active area of the capacitor being designed and the active area of the test sample (Fig. 49).

4.2.7 Check List of Significant Characteristics. In selecting the most appropriate capacitor for a particular application, the following characteristics should be considered in relation to application requirements in the interest of attaining the optimum balance of producibility, performance and cost.

CAPACITANCE

Rated value
 Tolerance
 Retrace
 Effect of:
 Temperature
 Voltage
 Age
 Pressure
 Frequency

VOLTAGE RATING

DC continuous
 DC Transient
 Polarity
 AC low frequency
 AC high frequency, RF

TEMPERATURE CAPABILITY**DISSIPATION FACTOR OR Q**

Power factor
 Equivalent series R
 Effect of:
 Temperature
 Voltage
 Frequency
 Capacitance

LEAKAGE CURRENT OR INSULATION RESISTANCE

Effect of:
 Temperature
 Polarity
 Age
 Voltage

STRAY CAPACITANCE AND RESISTANCE TO CASE**IMPEDANCE**

Effect of:
 Frequency
 Series R
 Series X_L

RIPPLE/PULSE CURRENT**FAILURE RATE**

Effect of:
 Voltage
 Temperature
 Ripple current
 Transients

FAILURE MODES**NOISE****VOLUME & WEIGHT PER μ F VOLT OR PER KVAR****MECHANICAL FEATURES**

Enclosure
 Mounting provisions
 Seal
 Flammability
 Effect of:
 Orientation
 Vibration
 Shock
 Humidity

COST**AVAILABILITY**

4.3 Magnetic Devices. Motors, generators, transformers, and inductors are magnetic devices requiring electrical insulation between turns of the coils, between coil layers, between adjacent coils, and between coils and associated parts such as the magnetic cores and structure.

The coil insulation in high-voltage rotating machines may be subjected to gaseous ionization or corona discharge during proof testing and in service. These partial discharges can occur externally from the windings to the metal frame or cores; and internally in voids or crevices in the insulation. Analyses of electrical failures in high-voltage magnetic devices have revealed erosion in the larger cavities of nonhomogeneous insulation. These

larger cavities may have initially developed by thermal aging, mechanical forces, or by partial discharge attack. A combination of these degrading effects is most likely.

The erosion or weakening of insulation through internal discharge attack may be the result of several effects progressing simultaneously:

- Thermal degradation caused by local heating from ionization streamers and increased losses in surrounding solid materials;
- Degradation of solid material and reaction with the gas in the cavity;
- Degradation of the gas and reaction with the cavity surfaces;
- Partial breakdown in solid material (treeing).

4.3.1 Encapsulation. Several manufacturers produce epoxy, polyurethane, and silicone dielectric materials which have been used successfully in aerospace magnetic devices. Some of these materials have restrictions; for example, a minimum operating temperature of -20°C . A material in a particular application may have worked well without restrictions, but the same material in a new application may require restrictions. Scotchcast 280 and 281 are examples. In a large transformer wound with AWG 24 wire, filled Scotchcast 281 was found to be the better product. The filler was fine enough to pass through the winding interspaces, completely filling the coil winding which was 25 cm in diameter, 2.5 cm thick, and 10 cm high. The coefficient of thermal expansion of the coils matched that of the Scotchcast 281 and no cracks or voids developed during temperature cycling between -40°C and $+85^{\circ}\text{C}$.

Another coil, designed for a higher voltage but lower current, was wound with AWG 32 wire, but the inner windings were not totally impregnated with Scotchcast 281, even after a vacuum treatment followed by nitrogen pressurization at five atmospheres. In a redesign the coils were impregnated with Scotchcast 280, and overcoated with Scotchcast 281. This led to difficulties because during the removal from the mold a grease film and dirt were deposited on the Scotchcast 280 by handling. This grease and dirt, where not completely removed, left the two materials poorly bonded, generating cracks and voids which contributed to high partial discharge counts in a subsequent corona

test. Incidentally, controlled introduction of additives between layers of a dielectric is a method of acquiring voids and cracks for testing to confirm theoretical models.

Some insulations will show excellent bonding to glass test tubes for great temperature extremes, but fail when used as a circuit encapsulation. Some materials may separate at the bond when applied to electrical parts; for example, silicone on epoxy materials, and acid-based silicone on water-based silicones. Occasionally a material will not harden when in a sealed evacuated container. Materials also may have bonding problems when subjected to thermal cycling; that is, the insulation will crack or delaminate when cooled to temperatures less than -20°C . Table 21 shows low-temperature performance of some of the dielectrics that are useful for magnetic devices.¹⁰⁷

TABLE 21
PERFORMANCE OF INSULATING MATERIALS AT LOW
TEMPERATURES AND 10^{-4} N/cm² PRESSURE

<u>Material</u>	<u>Voltage</u>	<u>Temperature</u>	<u>Comments</u>
PR 1538	600 Vrms	-40°C	Cracked. No damage - low voltage in vacuum
Solithane 113/300 Formula 12	15 KV	-18°C	Successful
Scotchcast 280/281	400 V _p	-55 to 85°C	Very thin coat Transformer okay
RTV 615 6154	15 KV 15 KV	-55 to 85°C -20 to 85°C	Cracked Successful
DC 3110	4 KV 4 KV	-36°C to 50°C -18°C to 50°C	Cracks appeared Successful
PC 22	1.0 KV	-30°C to 70°C	Successful
DC 3110 DC 1201 Primer	18 KV	-55°C to 70°C	Opaque material

107. W. G. Dunbar, "High Voltage Connections for Flight Vehicles," NAECON 74, National Aerospace and Elec. Conference, Dayton, Ohio, May, 1974

Insulations used for encapsulation and conformal coatings should be applied and then vacuum-pressurized. The coil should be properly cleaned beforehand, the encapsulant outgassed and poured into the mold containing the coil, and the encapsulated coil evacuated until bubbling ceases, followed by 2 to 3 atmospheres of pressurization. The pressurization will usually seal insulated wires by driving the encapsulant into the wire strands at the end of the wire. It will also force insulation into small intraspacial voids in the coils. X-rays may be used to verify large voids between high-voltage windings and grounded surfaces.

The electrical properties of some epoxies, silicones, and polyurethanes, having high service temperatures and good dielectric strengths are listed in Table 22. A more complete listing of the thermal, mechanical, and chemical properties of Scotchcast 281 epoxy is shown in Table 23. A listing of many materials used for encapsulating equipment can be found in Reference 108.

4.3.2 Terminal Boards and Supports. Composite and laminated insulation is used for terminal boards, and also for supports that separate the coils and wiring from the cores, structure, and containers. Some electrical and mechanical properties of glass and nylon containing laminates are shown in Table 24. A more complete list of materials and properties can be found in References 108 and 109.

A terminal board for high potential should be made from qualified insulation. The board may be flat, if the voltage is less than 20 kV, provided the electrical stress is:

Less than 10 volts/mil for long life (10-30 years)

Less than 10-25 volts/mil for short life (1 month to 1 year)

with treated boards in a dry, clean, atmosphere of pure gas these values can be increased 3 times the above value.

108. J.F. Sutton and J.E. Stern, "Spacecraft High-Voltage Power Supply Construction," NASA Tech. Note., NASA TN D-7948, Goddard Spacecraft Center, Greenbelt, Md., April, 1975
109. H.L. Saums, and W.W. Pendleton, Materials for Electrical Insulating and Dielectric Functions, Hayden Book Co., Rochelle Park, N.J. 1973, pp 129-155

TABLE 22
SUCCESSFUL AEROSPACE DIELECTRIC MATERIALS

<u>Material</u>	<u>Service Temperature °C</u>	<u>Dielectric Constant</u>	<u>Dielectric Strength V/mm</u>	<u>Volume Resistivity Ohm - cm</u>
<u>EPOXIES</u>				
XR5192	130	4.62	11,000	1.5×10^{13}
Scotchcast 3	130	3.3	12,000	1×10^{15}
Scotchcast 235	130	5.2	13,000	1×10^{15}
Scotchcast 280	155	4.9	15,000	1×10^{14}
Scotchcast 281	155	4.9	15,000	1×10^{14}
<u>SILICONE RUBBER</u>				
RTV-11	204	3.6	20,000	6×10^{14}
RTV-60	204	3.7	20,000	$1 \times 3 \times 10^{14}$
RTV-615	204	3.0	20,000	1.0×10^{15}
RTV-616	204	3.0	20,000	1.0×10^{15}
Sylgard 182	200	2.7	22,000	2.0×10^{14}
Sylgard 184	200	2.75	22,000	1.0×10^{14}
Sylgard 186	250	3.0	23,000	2×10^{15}
<u>POLYURETHANES</u>				
Solithane 113	121	2.8 - 5.0	13,000 - 20,000	3×10^{14}

Terminal boards operating at voltages greater than 20 kV should be contoured to increase the creepage paths. Three basic methods of contouring are:

- Cutting slots (gas filled regions) between the terminals.
- Building barrier strips between the terminals.
- Mounting the terminals on insulated standoffs.

TABLE 23
 PROPERTIES OF 3M SCOTCHCAST 281 EPOXY

<u>PROPERTY</u>	<u>VALUE</u>
Coefficient of thermal expansion	1.5×10^{-4} cm/cm ^{°C}
Thermal conductivity	1.2×10^{-3} cal/cm-sec ^{°C}
Specific gravity	1.43
Water absorption	0.4%(weight) in 1000 hours at 23 ^o
Shore hardness Number	D65
Service temperature range	-55 ^o C to 155 ^o C
Shelf life (before encapsulation)	12 months
Dielectric constant	4.9 at 100 kHz
Dissipation factor	0.05 at 100 kHz
Dielectric strength	15kV/mm
Volume resistivity	1×10^{14} ohm-cm
Flammability	Self extinguishing
Transparency	Opaque

These three methods are shown in Fig. 50. A combination of the three methods may be necessary for voltages greater than 100 kV. The slots in a slotted board form creepage paths and flashover barriers on both sides of the board. A board with barriers is the most difficult to design. The barriers must be built on both sides of the board, and the board has to be made from materials that will not form creepage paths under the barriers, or in laminated boards, through the board laminates. The barriers must not interfere with the terminals or the wiring.

TABLE 24
 PROPERTIES OF LAMINATES AND COMPOSITIONS

Material Properties

<u>NEMA Grade</u>	<u>Base Material</u>	<u>Resin</u>	<u>Specific Gravity</u>	<u>Water % absorption</u>
G-7	Glass cloth	Silicone	1.68	0.55
G-9	Glass cloth	Melamine	1.9	0.8
G-10	Glass cloth	Epoxy	1.75	0.25
G-11	Glass cloth	Epoxy	1.75	0.25
N-1	Nylon	Phenolic	1.15	0.6
FR-4	Glass	Epoxy	1.75	0.25
FR-5	Glass	Epoxy	1.75	0.25

Mechanical Properties

	<u>Flexural Strength</u> $N/m^2 \times 10^8$ 1.6mm thick	<u>Tensile Strength</u> $N/m^2 \times 10^8$	<u>Compressive Strength</u> $N/m^2 \times 10^8$	<u>Bond Strength</u> kg	<u>Rockwell Hardness</u> M-scale
G-7	1.4	1.6	3.1	295	100
G-9	4.1	2.7	4.5	770	--
G-10	4.1	2.4	4.8	900	110
G-11	4.1	2.4	4.8	725	110
N-1	0.7	0.6	1.9	450	105
FR-4	4.1	2.4	4.8	900	110
FR-5	4.1	2.4	4.8	725	110

Electrical Properties

	<u>Dielectric Constant</u> 1 MHz 0.8mm	<u>Dissipation Factor</u> 1MHz 0.8mm	<u>Dielectric Strength</u> Kv/mm (0.8mm)	<u>Resistivity</u>		<u>Arc Resistance</u> Sec.
				<u>Volume Resistivity</u> GHM-Cm	<u>Surface Resistance</u> Megohms	
G-7	4.2	0.003	11	--	--	180
G-9	7.5	0.018	10	--	--	180
G-10	5.2	0.025	20	10^{12}	10^4	128
G-11	5.2	0.025	16	10^{12}	10^4	115
N-1	3.9	0.038	15	--	--	--
FR-4	5.2	0.025	18	10^{12}	10^4	128
FR-5	5.2	0.025	18	10^{12}	10^4	128

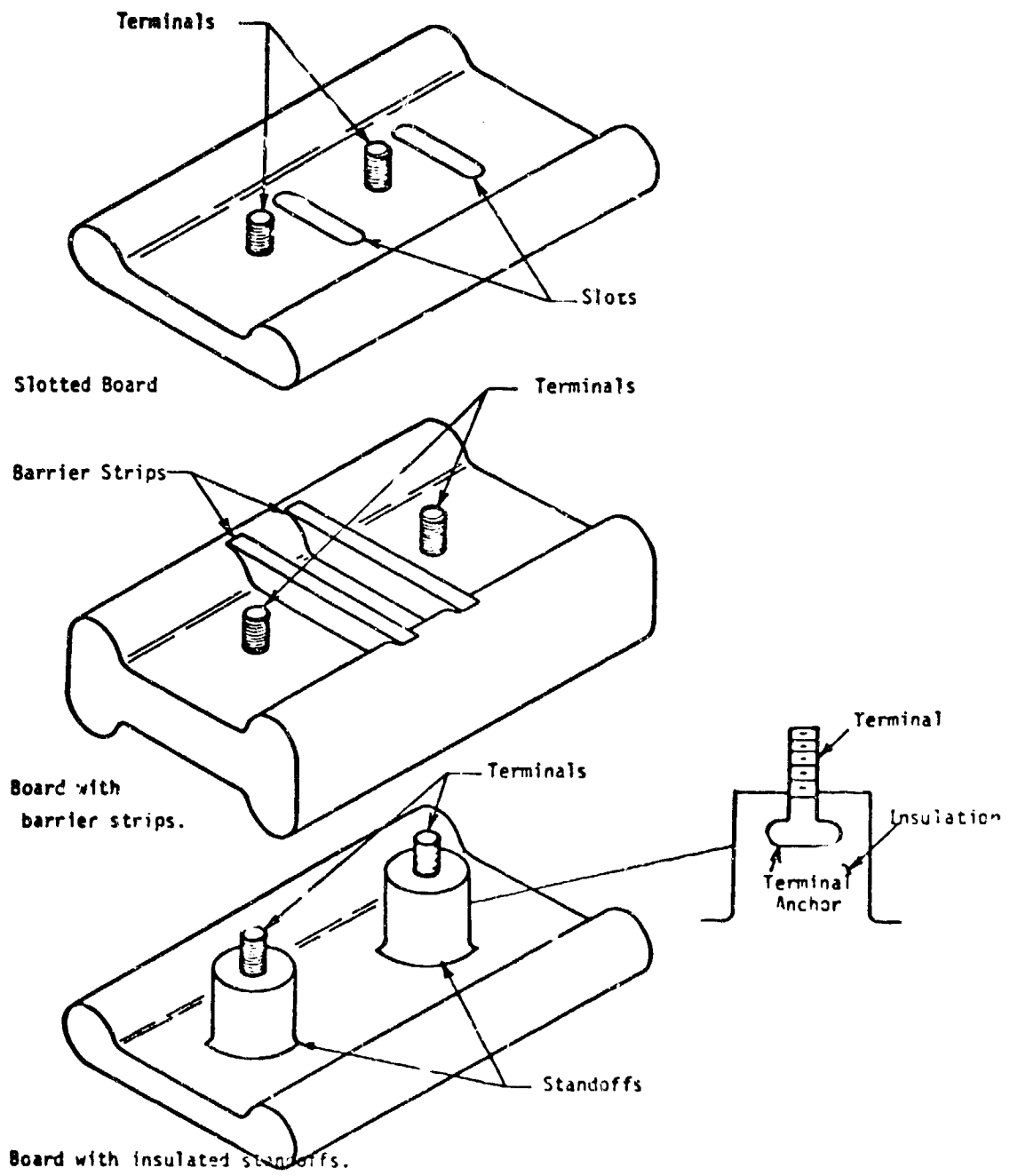

FIGURE 50. TERMINAL BOARDS

Insulated standoffs are a form of the barrier strips. They are difficult to design because they must withstand the forces applied by the terminals, and the terminal anchor must be embedded in the top surface of the standoff. The anchor must be contoured for minimum electrical stress.

4.3.3 High Voltage Leads. Leads between high voltage parts should be made of round, smooth-surfaced polished metal tubing. Steel and nickel-plated metals are preferred, but other softer metals are often used because they are easier to fabricate. The radius of curvature on all bends should be at least 2.5 times the conductor diameter to avoid flattening or crushing the tube at the bend. The ends of the tubes should be flattened as little as possible but this becomes difficult for pieces other than straight sections. When the end of the tubing is flattened the corona suppression shield should extend over the edges and the flattened end of the tubing as shown in Fig. 51. Ample space must be provided between the inside surface of the insulator and the metal tube. A safe design would be based on the assumption that the full voltage stress exists on the top edge of the bushing.

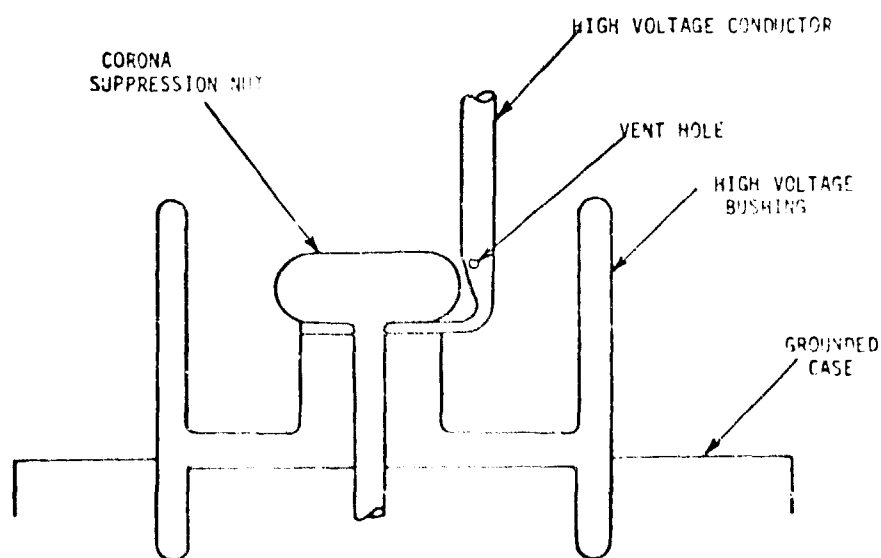

FIGURE 51. HIGH VOLTAGE LEAD AND BUSHING

Hollow tubing must be vented. Vent holes should be drilled through one wall of the tubing at both ends. The vent hole should face the corona shield. No other holes should be drilled in the tubing.

4.3.4 Special Design Features. High voltage flexible lead terminations should be designed to eliminate pressure points on the terminal board (Fig. 52) Pressure points will cause delamination which enhances internal tracking. Also, the terminal should be protected with a corona ball or shield.

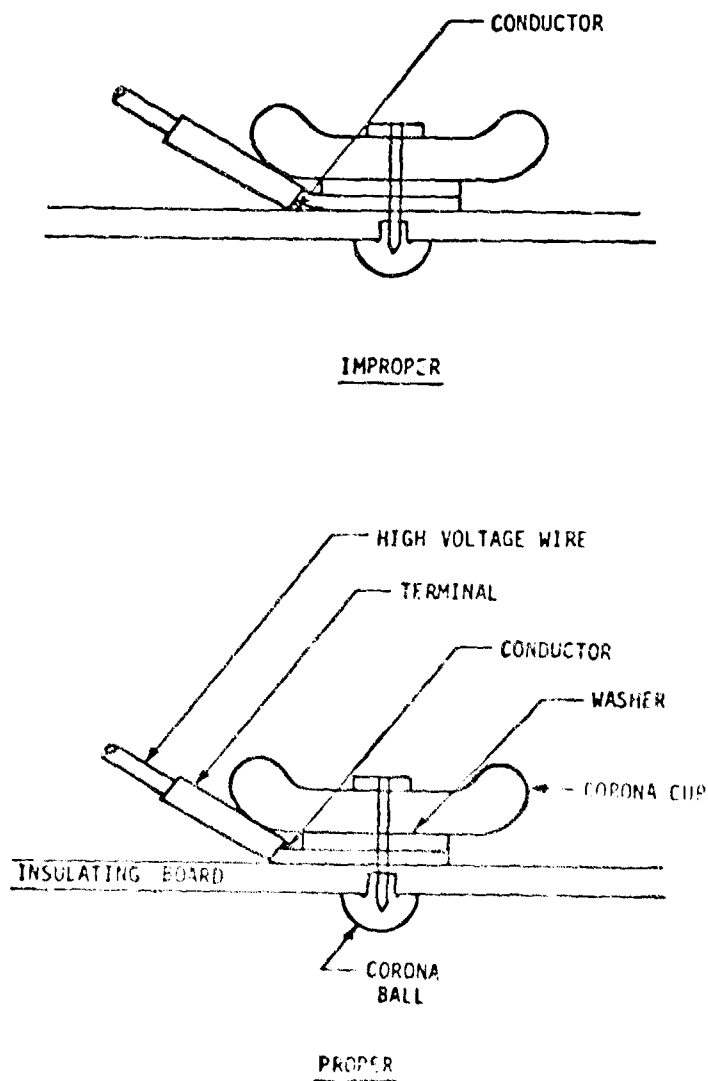

FIGURE 52. HIGH VOLTAGE TERMINALS

Other insulation techniques include either burnishing or enameling over the knots in ties. Otherwise, the feathered ends will become points from which corona discharges will emanate (Fig. 53).

Small pieces of insulation must be cleaned out of the transformer case. Otherwise the "chips" may lodge in the field between a coil and metal, cause corona, which ruins the gas or oil. Wire terminations should be designed and installed so the field approaches that of a parallel plate configuration without point discontinuities.

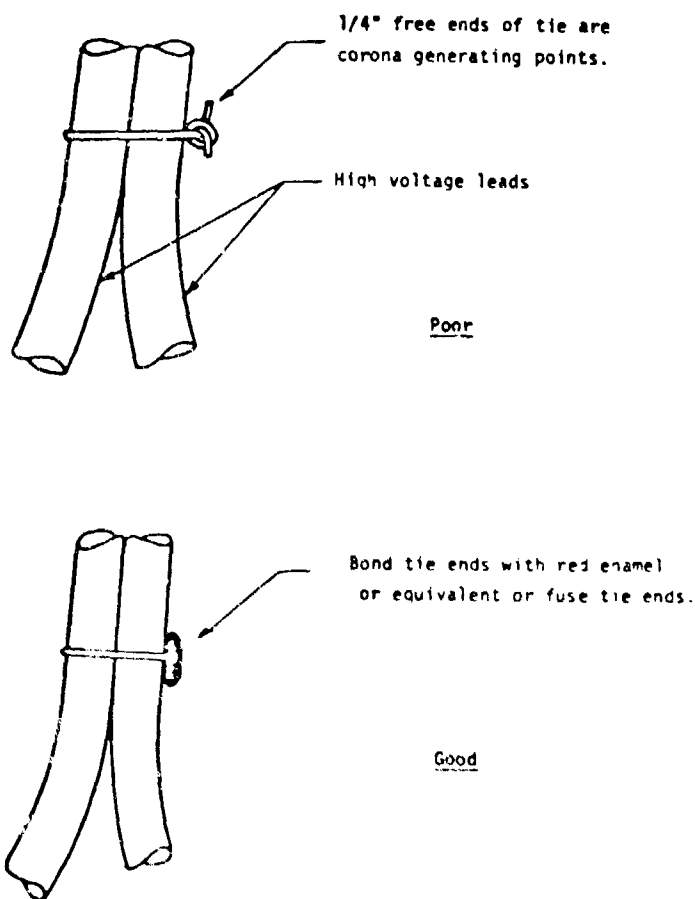

FIGURE 53. HIGH VOLTAGE TIES

Encapsulated coils and the coil supports should have rounded corners (Fig. 54). Rounding the corners eliminates high stress points or low utilization factors in the media between the encapsulated coil and its support, fram, or adjacent coil.

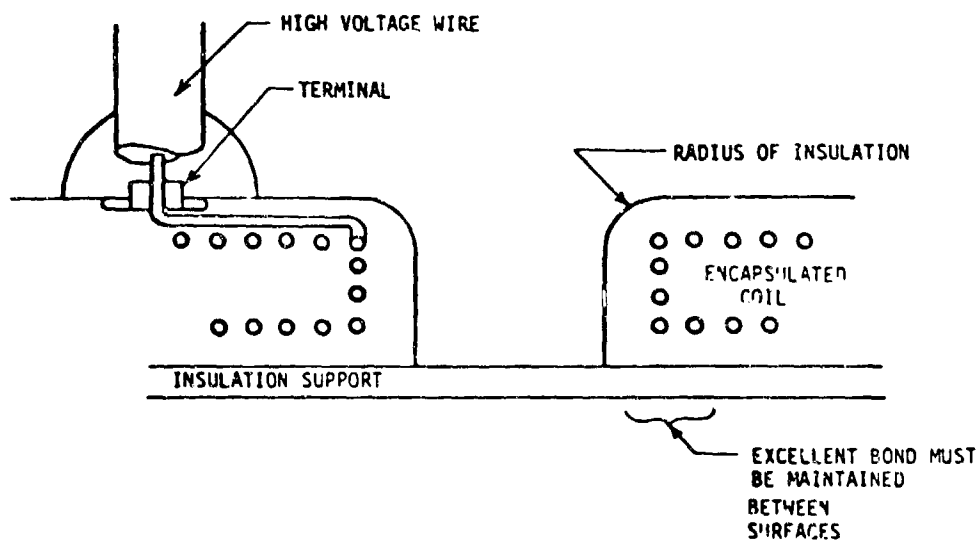

FIGURE 54. ROUND CORNERS ON ENCAPSULATED COILS

4.4 Solid State and Vacuum Parts. Sometimes in aircraft installations, live high voltage circuits must be switched. Devices used to switch aircraft high voltage are hard-vacuum tubes, hydrogen thyratrons, silicon controlled rectifiers (SCR's), and vacuum switches. Associated with these components are resistors, capacitors, wiring, magnetic devices, isolating transformers, or electro-optical isolators, and triggering circuits. A device sometimes used in high voltage circuits is the crowbar, which very quickly shunts the high-voltage conductors with a resistor to harmlessly discharge energy storage capacitors to prevent a damaging dissipation of energy into a fault.

High voltage circuit components protected by a crowbar circuit may be subjected to large voltage transients and excursions preceding and during faults. These transient voltages may be either negative or positive and more than double the normal circuit voltage with high frequency voltage components. The insulating surfaces and thicknesses must be capable of withstanding multiple crowbar actions. Therefore, insulation used in and around these circuits must have a basic insulation level. Boards, terminals, bushings, and other insulation must be impulse tested to show capability for withstanding at least 100 to 500 impulses. See Impulse Testing, paragraph 5.3.3.

The selection of high-voltage switches is beyond the scope of this design manual. The following paragraphs deal with the installation of high-voltage switches and their auxiliaries, and the techniques of making safe and corona-free electrical connections.

4.4.1 Fields. The high voltage insulation design starts with a circuit diagram showing all parts and their voltage levels. The parts are then arranged in a preliminary package which minimizes the voltage between parts and voltage across each part. In designing high voltage assemblies, it is important to avoid crossovers that put a low voltage surface on one part next to a very high voltage surface of another part. Circuits containing resistive or capacitive voltage dividers require careful design, especially if the resistor is long. For instance, a resistor or group of resistors may be a voltage divider between the high voltage terminal and ground. The normal plan is to zig-zag many resistors from the high voltage terminal to the ground terminal, or to have one resistor with one end attached to the high voltage terminal and the other end grounded. Sometimes other high voltage parts near the center of the resistor or resistor chain may be at full voltage or at ground potential, stressing a zone which is not normally designed for voltage stress. This must be avoided.

4.4.2 Taps and Plates. A high voltage rectifier is normally assembled from a series of connected diodes. Occasionally, a voltage tap is required at the center of the diode string. This tap should be made of material having the same diameter as the diode surface, and thick enough for attachment of a round tubular connection. Soldered joints should not

be used because most solder electrodes have lower breakdown potentials than do metals such as steel, nickel, brass, copper, and aluminum.

A potential shaping surface within a stack of series-connected diodes can be a thin plate of metal, provided with a large-radius edge as shown in Fig. 55. This curved edge suppresses corona.

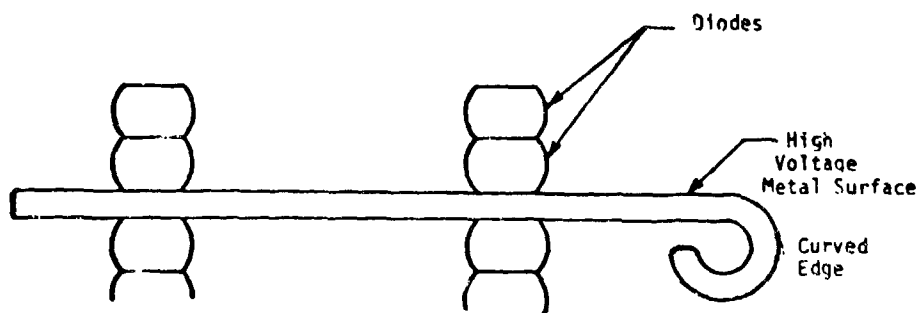

FIGURE 55. CURVED EDGE ON HIGH VOLTAGE PLATE

4.4.3 Control Wiring. High voltage units may use circulating pressurized gas for part of the insulation system, and also for cooling parts.

Electrically controlled switches may also be required for system voltage regulation and performance measurement. These functions are done with components such as fan motors, relays, motor-driven switches, and instrumentation, sensors and circuits, operating at voltages less than 250 volts rms or dc. These devices and circuits as normally insulated are incapable of withstanding the induced transient voltages coupled into them by high voltage faults, crowbar action, and the high voltage start-stop sequences. Therefore, these circuits and their wiring must be shielded.

Low voltage devices and their wiring must be kept away from the high voltage circuits. Low voltage conductor shielding has rough surfaces which

look like multiple points that enhance field gradients with respect to the high voltage, lowering the breakdown voltage between high voltage parts or conductors to the low voltage shields.

Shielding the low voltage components and wiring should be adequate to hold the induced impulses to less than 750 volts peak in common-mode and differential-mode circuits, and to less than 7500 volts peak in the wiring. These limits will prevent destruction of most hardened solid state devices, inductors, capacitors, and resistors used in the control circuits. Many circuits have been evaluated for damage or malfunction by electromagnetic pulses. Some of these data were compiled in Reference 110.

4.4.4 Insulated High Voltage Wiring. A designer may have to interconnect two or more components with a high voltage flexible wire which has insulation inadequate to sustain the full electrical stress of the applied voltage. He can do this if he:

- (1) Increases the diameter of the wire with more insulation. With dc voltage stress, the low resistance of the insulation and near infinite resistance of the gas, will allow the surface of the wire insulation to charge to the conductor voltage level. This larger diameter will lower the voltage gradient in the highly stressed gas next to the conductor. With ac, the voltage at the surface of the wire will be determined by the configuration and dielectric constants of the wire insulation and gas space.
- (2) Provides adequate and rigidly controlled spacing between the wire and ground planes.

Generally, extra-flexible wire should be used only when the bending and intertwining of the tubing through the high voltage volumes is too difficult

110. ---"Component Damage/Malfunction Levels," Technical Memorandum, TM-75, Prepared for U.S. Army Engineering Division, Huntsville, Corps of Engineers, Contract DAC87-72-C-0002, Submitted by Boeing Aerospace Company, Seattle, Washington, December 1974

or will mechanically stress parts during installation. Terminations on extra-flexible wire will not stay in place as they will with solid tubing. Therefore, the terminations must either be keyed to a slot in the insulation barrier, or a special locking device must be developed for the termination and/or wire end.

5. TESTS

High voltage insulation is tested to evaluate its physical and electrical properties and to predict its service life. Equipment tests should be designed to verify the quality of the insulation rather than to serve as a failure analysis tool.

5.1 Insulation Tests. There are two categories of insulation testing: 1) material evaluation and 2) component insulation tests.

Material evaluation tests include tests of the electrical and physical properties. Electrical properties are dielectric strength, dielectric constant, dissipation factor, surface resistivity, volume resistivity, surface resistance, and life at pertinent temperatures. Physical properties include flexural strength, tensile strength, wrap and twist, water absorption, linear and bulk coefficient of thermal expansion, heat capacity, chemical resistance, and flammability. Materials are usually evaluated in commercial testing laboratories and in laboratories operated by manufacturers of insulation.

Component evaluation tests which are designed to evaluate insulation integrity and life, involve measurement of 1) insulation resistance, 2) dielectric withstanding voltage (DWV), 3) basic insulation level (BIL), and 4) corona. Insulation resistance and DWV tests are mandatory, BIL and corona tests are desirable.

5.2 Materials Testing. An accepted standard electrical insulation code, by defining nomenclature and test requirements for the high voltage insulating materials, would enable the design engineer to establish test hardware quantity, test parameters, and needed test equipment. Such a code does not exist in a form satisfactory for aircraft work. The best thing the designer can do is to adapt ASTM, IEEE, and NEMA high voltage testing standards to his aircraft application.

The following sequence of testing will prevent a high potential from being applied to the insulation which may not be in suitable condition for such a test:

1. Visual inspection
2. Insulation resistance measurements
 - Volume resistivity
 - Surface resistivity
3. High potential applied to solid insulation between two metal electrodes.
4. Tracking
5. Final insulation resistance measurement
6. Life test

Electrical insulation when received should be inspected to confirm dimensions and to find any flaws, hidden moisture, dirt or other contaminants. Its insulation resistance should be measured and it should be subjected to a high potential test, to measure leakage.

ASTM Tests. Present ASTM standard tests do not impose all the operating-environmental conditions on airborne equipment. Therefore ASTM tests should be modified by adding the altitude environment and a time-temperature schedule. ASTM high potential tests for terrestrial equipment are not completely applicable to airborne equipment, but are useful for detecting insulation flaws and incipient failures which will show up after the insulation ages.

Electrical properties of insulating materials should be measured in accordance with the test methods in Table 25. Electrical insulation when received should be inspected to confirm dimensions and to find any hidden moisture, dirt or other contaminants. The insulation resistance should be measured, and then the insulation should be subjected to a high potential test to measure leakage current.

5.3 Component and Equipment Tests. The purpose of testing components and equipment is to determine their flightworthiness. The suggested order for these tests is: insulation resistance, high potential (DWV), impulse (BIL), and

TABLE 25
TESTS OF ELECTRICAL PROPERTIES OF INSULATION

<u>TESTED PROPERTY</u>	<u>TEST CONDITION</u>	<u>EVALUATED</u>	<u>TEST METHOD</u>
Dielectric Strength	DC/AC 1/4" Electrodes	When received and following environmental stress	ASTM, D-149-61 (Modified)
Tracking	DC/AC	Following environmental stress	ASTM D-495 or ASTM D-2302
Dielectric Constant	1 Kilohertz	When received	ASTM, D-150-59T
Dissipation Factor	1 Kilohertz	When received	ASTM, D-150-59T
Volume Resistivity	125 volts	When received and following environmental stress	ASTM, D-257-61 (Modified)
Surface Resistivity	DC	When received and following environmental stress	ASTM, D-257-61 (Modified)
Insulation Resistance	DC	Following environmental stress	Based on 0.05 mfd wound parallel- plate capacitor
Life	DC/AC	Vacuum (Plasma)	ASTM, D2304-64T (Modified)

partial discharge test. Partial discharge test instruments are usually referred to as corona test sets.

5.3.1 Insulation Resistance. Insulation resistance is tested by applying across the insulation a low voltage, like 50 to 100 volts dc. An instrument sensitive enough to detect picoamperes measures the resulting current, and the insulation resistance is calculated with Ohm's law.

Insulation resistance should be measured prior to high potential tests to avoid unnecessary failures from defective, damp or dirty insulation. High insulation resistance by itself does not prove that the insulation of a component does not have cracks or other faults where insulation breakdown may subsequently start. Therefore, an insulation resistance test is not a substitute for high potential tests, which should follow an acceptable insulation resistance test.

Insulation resistance should also be measured after high potential tests because insulation damage from a high potential breakdown may otherwise be difficult to detect. Lower insulation resistance after a high potential test indicates a failure. Obviously, insulation resistance must be measured both times at the same temperature.

The test current during measurement of insulation resistance should be limited to 5 milliamperes with the voltage source shorted. Most "Megger" instruments limit direct current output to 4 milliamperes or less. This limitation avoids unnecessary heating of the insulation at the leakage paths if the insulation resistance is low. Insulation resistance that is low because of moisture can usually be restored by baking.

5.3.2 High Potential Test. In a high potential test the intentional grounds of the component being tested are disconnected, and the voltage is applied between mutually insulated elements of the electric equipment and between insulated elements and the frame or "ground." For example, in a three phase Y-connected alternator the windings would be ungrounded at the common point. Normally, the test voltage should not appear across solid-state devices.

A common test voltage for 28-volt and 120-volt equipment is two times normal plus 1000 volts. Some airborne equipment is tested with lower voltage, especially if short-life and dense-packaging is involved. Sometimes this equipment is designed with a DWV that is less than 150 percent of the operating voltage, it should be at least 150 percent for quality hardware.

High potential tests are designed to electrically stress high voltage components and equipment, but with safety margins sufficient to protect the equipment from damage or malfunction. The basic damage/malfunction mechanism for components and equipments relates to the DWV. Parts with similar and/or identical electrical insulation should have similar or identical DWV.

High potential tests are intended to detect insulation flaws, discontinuities, aging cracks, and deteriorated or inferior insulation. A hole or crack in insulation, through which an inductive surge voltage will discharge and ultimately "carbonize" a conductive path, may be detected by a high-potential test if the test voltage is high enough. Test voltages under 1000 volts rms are too low.

The high potential should be applied for 60 seconds. Repeated application of high potential test voltages can reduce the dielectric strength of insulation. Whether any significant reduction in dielectric strength occurs depends on the number of tests, the insulation material, and the insulation thickness. Up to ten high potential tests would probably not permanently damage the insulation.

Some systems have large voltage-transients generated by rectifiers or mechanical switches. The DWV test must exceed the highest of these transients by at least 20%. Each application must be assessed on the basis of required operating life and operating conditions.

5.3.3 Impulse Tests. Impulse or basic insulation level (BIL) tests are required for components and equipment which will be used where electromagnetic pulses (EMP) or switching surges are expected. A BIL test subjects the insulation to a voltage pulse having a rise time of about one microsecond.

High voltage public utility apparatus is specified to meet lightning and transient insulation standards, in addition to the dielectric withstanding voltage requirements. These transient requirements are referred to as the basic insulation level (BIL) for the insulation system. The BIL is based on an impulse with slower rise and longer duration than an EMP. Thus, using the BIL is a conservative approach to designing electrical insulation for fast EMP transients. The slowest EMP transients are essentially the same as the BIL standard transient.

Basic insulation levels were defined during the joint January 1941 meeting of AIEE-EEI and NEMA Committees. This group adopted the basic insulation levels in terms of impulse voltages according to the following definition:

"Basic impulse insulation levels are reference levels expressed as impulse crest voltage with a standard wave no longer than 1.5×40 microseconds (1.5 microseconds rise to 0.90 peak voltage and 40 microseconds decay to 0.5 peak voltage) (see Figure 56). Apparatus insulation as demonstrated by suitable tests shall have capability equal to, or greater than, the basic insulation level."

The above requires that equipment/components conforming to the definition shall have an impulse test value not less than the kilovolt magnitude entitled basic insulation level (BIL). Also, equipment/components conforming to these requirements, with a few exceptions for solid-state devices, should be capable of withstanding the specified voltage, whether the impulse is positive or negative in polarity. Standard atmospheric conditions are assumed.

The joint IEEE-EEI and NEMA committees have agreed upon BIL values for high voltage transmission and distribution equipment/components to ensure continuous system operation during and following lightning and transient conditions. The committee has not standardized BIL values for all low voltage and airborne electrical equipments, that is, equipment/components with operating voltages less than 1200 volts rms (1700 volts crest) or equipment/components operating at altitudes above 10,000 feet.

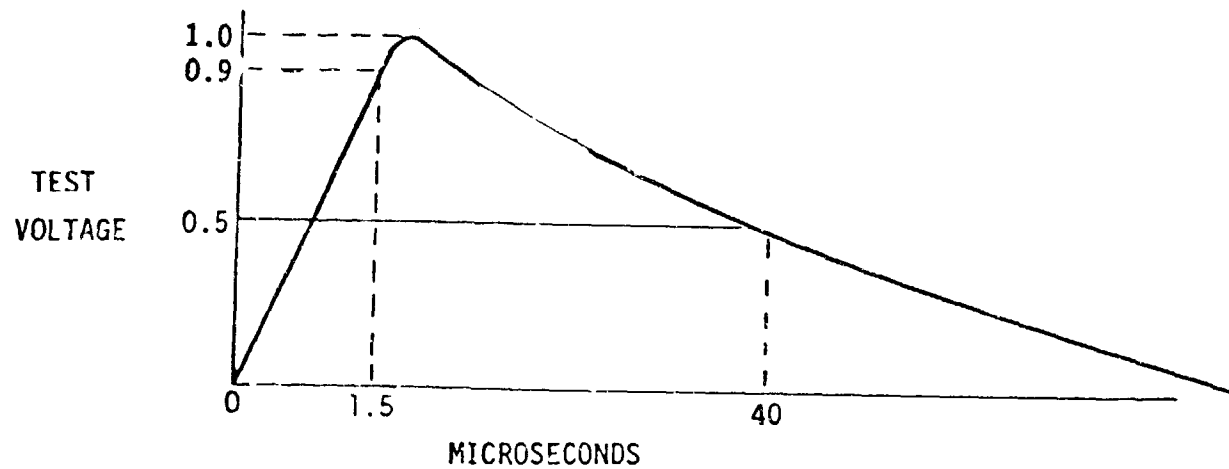

FIGURE 56. WAVEFORM FOR BASIC INSULATION LEVEL (BIL) DEFINITION

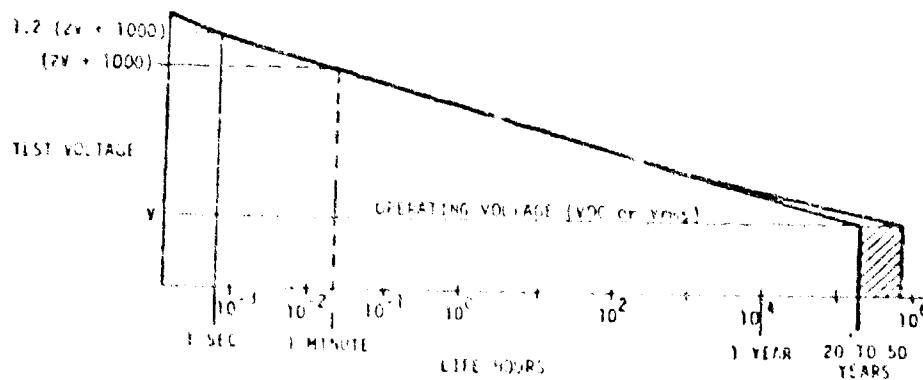

FIGURE 57. DIELECTRIC-WITHSTANDING-VOLTAGE MARGIN AFFECTS INSULATION LIFE

Insulation is able to withstand higher voltages, within limits, as the test duration becomes shorter (Figure 57). Experiments have shown that insulation will function for 20 to 50 years if its initial 1-minute dielectric withstanding voltage (DWV) is two times the operating voltage plus 1000 volts. Experiments have also shown that the electrical insulation breakdown voltage could be increased 20 percent if the DWV time was decreased from 1 minute to 1 to 5 seconds.

Most experimental work has been with either 50 to 60 Hz ac or steady-state dc. Power industry tests show that the steady-state dc voltage that a given insulation can withstand is higher than the crest value of the ac voltage it can withstand. When a dc voltage is applied the dielectric is charged only once. On the other hand, the recurring charging and discharging with an ac applied voltage heats the dielectric by electrically stressing the molecules in the dielectric. When steady-state dc voltage is applied, the only heating of the dielectric is from current flow through the insulation resistance. Early experiments with insulation showed the dc rating of insulation to be:

$$\text{Rating in volts dc} = (1.7 \text{ to } 2.3) (\text{ac rating in volts rms}) (5-1)$$

Factors which decrease the impulse level an insulation can withstand are material aging, power system transients experienced, and the maintenance status of the equipment. Insulation impulse ratings are decreased to the range of 0.75 to 0.85 of their original values by these phenomena.

An insulating material is also degraded by repeated impulses. This degradation is time variant (Figure 58), with less than 10 impulses having little effect on the insulation integrity. The data in Figure 58 implies that the breakdown of insulation proceeds with the growth of pre-breakdown channels created by previous pulsing, a process having three distinct phases: (1) An initial period during which the impulses initiate a pre-breakdown channel, (2) a slow growth of the channel, and (3) a fast growth of the channel. For example, over 10,000 pulses were required for the slow growth of the channel in epoxy insulation for a pin-to-plane configuration, with the pin spaced 5 millimeters from the plane (Ref. 111).

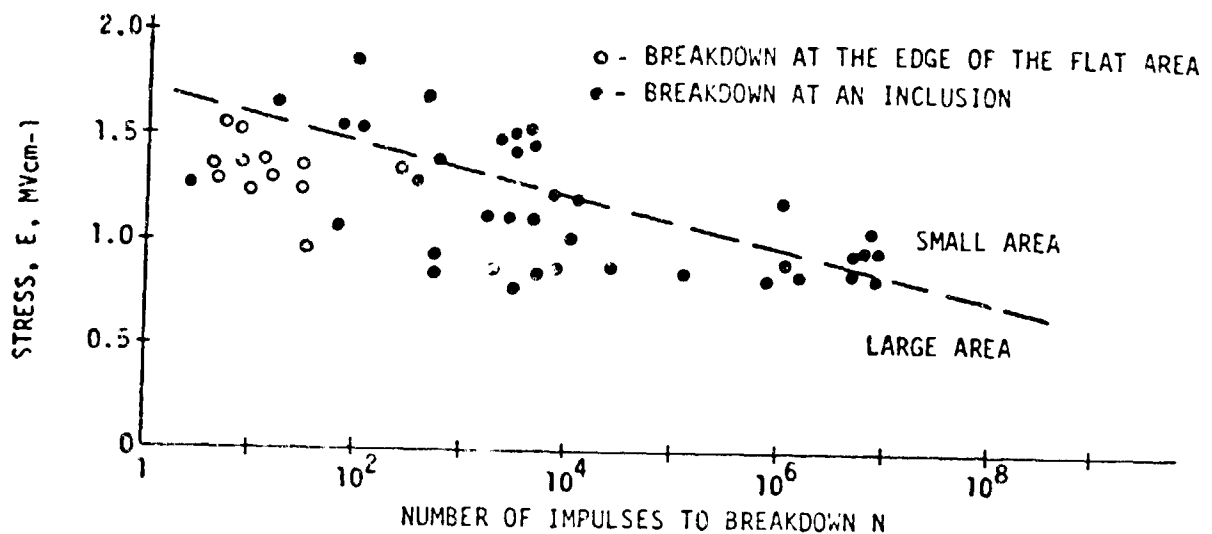

FIGURE 58. RELATION BETWEEN ELECTRICAL STRESS AND NUMBER OF IMPULSES REQUIRED TO PRODUCE BREAKDOWN WITH 1/50 MICROSECOND IMPULSES

Impulse voltages for public utilities are much too high for airborne equipment, where compact packaging requires small bushings and minimum dielectric thicknesses. Although airborne equipment is not normally designed to withstand lightning-induced transients, its impulse test voltages should still be twice the DWV.

5.3.4 Corona Tests. Corona tests are used to seek out insulating material flaws by detecting partial discharges in spaces, cracks, and voids.

The most common insulation imperfections are entrapped gas in voids, cracks within insulation, and insufficient space between an insulated conductor and ground or other insulated parts. For example, a generator coil may have small voids within the insulation, between the active conductors and generator

111. S. Zoledziowski and S. Seay, "Life Curves of Epoxy Resin Under Impulses and the Breakdown Parameter," IEEE, Transactions on Electrical Insulation, Vol. EI-7, No. 2, June 1972, p. 84-99.

magnetic core, or between the turns of two coils within a slot. High voltage coils in the stator will have air gaps between the surface of the coil and the rotor, and between the end turns and the core.

Electronic, sonic, and visual detectors are used to sense and measure partial discharges. These discharges can also be photographed, or observed with photomultipliers. Even their sound has been detected and triangulated to pinpoint the source.

With electronic detectors, both the partial-discharge initiation voltage and the extinction voltage are usually measured. The waveform of the partial-discharge pulse is observed to determine the magnitude and type of discharge. The variation in the number and sequence of pulse heights as a function of voltage and time can be measured, and the pulse energy can be derived from the voltage waveform. From such observations important insulation characteristics are established, including voltage rating, quality of insulating materials, quality of insulation design, insulating materials life potential, and type and size of voids and cracks.

Not enough is known about partial discharges and their effect on materials for their measurement to be the only criterion for insulation life assessment for a given applied voltage. Other tools such as high potential testing, impulse testing, dielectric stress calculation, and life testing are required for a full assessment.

Partial discharge detectors have been designed and calibrated for commercial testing of high voltage transmission lines, electrical machinery, and for testing small samples of dielectric gases and materials. During test, these detectors are directly or indirectly coupled to the test article. Examples are a resistor or coil in series with the test article, and a capacitor soldered to it. These directly coupled detectors, unless modified, are unsuitable for vacuum testing.

The output of the detector must be processed to extract the partial-discharge signature from the noise. A refined bridge circuit that nulls out

transients generated in the power supply is shown in Figure 59. For precise measurements a pulse-height analyzer is used with detection circuits for permanent recording of test data and for evaluating erosion of materials (Figure 60).

Requirements for Partial Discharge Detection. Detectors placed near the article should not distort the electric fields or operating characteristics of the test specimens or articles. The detectors must be sufficiently sensitive so that they can be spaced away from the critical parts of the high voltage field.

Capacitance coupled detectors are recommended for attachment to specific circuits. These detectors give accurate wave shape readout, have excellent response, and are easily installed. The radio frequency coil is recommended for noise pickup because it can be moved about to identify extraneous laboratory generated noise. Finally, either the loop antenna or electrometer are useful for surveillance in vacuum chambers. These detectors are lightweight, easily mounted and are insensitive to light and heat.

Frequency, Waveform and Interference. Assessing the effects of frequency and waveform requires careful instrumentation. Most commercial detectors, as recommended by the ASTM D9.12.12, Section L, Committee on Corona, are designed to operate with either dc or sinusoidal ac, with 50 and 60 Hz ac frequencies preferred. Only recently, (January 1976) did J.G. Biddle Company make a 400 Hz detector and readout which has been needed for many years. Most investigators working with corona and partial discharges have tested, when possible, with 50 or 60 Hz, and extrapolated the resulting data to 400 Hz. When testing dc-to-dc converters having frequencies from 1000 Hz to 20 KHz, they modified their detection equipment to accommodate these frequencies.

With square waves, the detector will pick up the leading and trailing fronts of each wave and display them as very large pulses which look like partial discharges having hundreds of pico-joules of energy. These pulses will, of course, have to be separated from true partial discharge pulses in the subsequent processing. An oscillator, if used, must be kept from becoming overdriven. The detector signal from the test is normally amplified by a high frequency

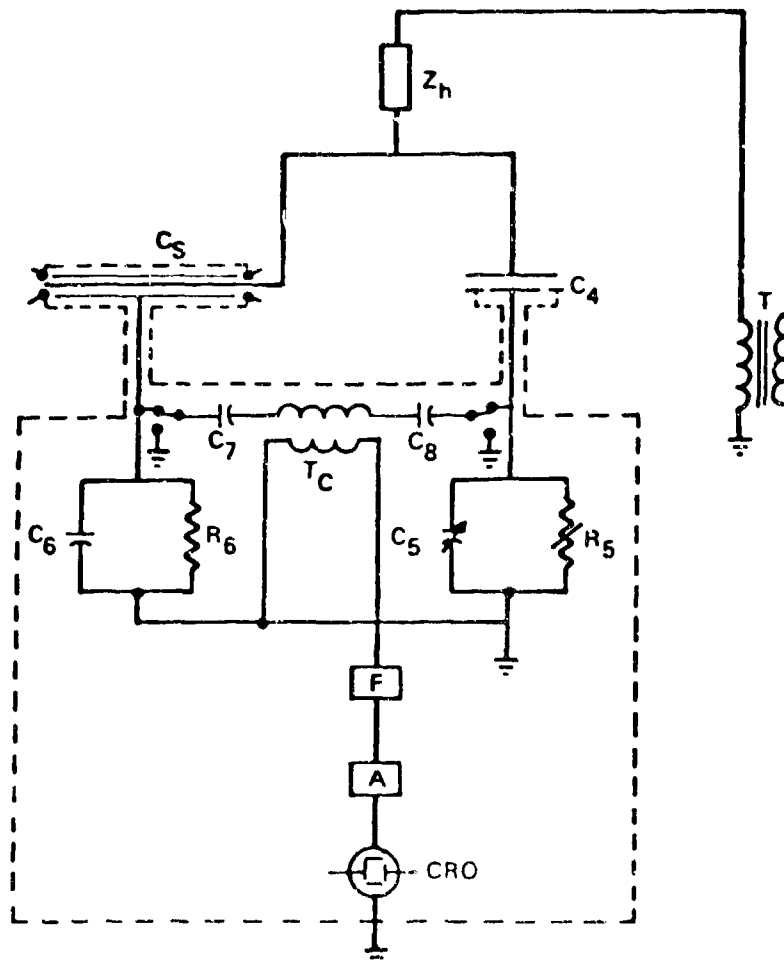

FIGURE 59. BRIDGE DETECTOR CIRCUIT

- T — HIGH VOLTAGE TRANSFORMER
- Z_h — SEPARATING IMPEDANCE (MINIMUM INDUCTANCE 0.1 H)
- C_s — CAPACITANCE OF TEST ARTICLE
- C_4 — COUPLING CAPACITANCE (1,500 TO 3,000 pF)
- C_5 — VARIABLE LOW VOLTAGE CAPACITANCE (0 TO 10,000 pF)
- C_6 — LOW VOLTAGE CAPACITANCE (1,000 TO 3,000 pF)
- C_7, C_8 — FILTERING CAPACITANCE (1,000 pF)
- R_5 — VARIABLE RESISTANCE (0 TO 100,000 OHMS)
- R_6 — RESISTANCE (200 TO 1,000 OHMS)
- T_c — COUPLING TRANSFORMER (INDUCTANCE OF WHICH IS CHOSEN SO TO OBTAIN OSCILLATION FREQUENCY 15 TO 30 KC/S)
- F — BAND PASS FILTER (PASS BAND 10 TO 50 KHZ)
- A — AMPLIFIER
- CRO — OSCILLOSCOPE

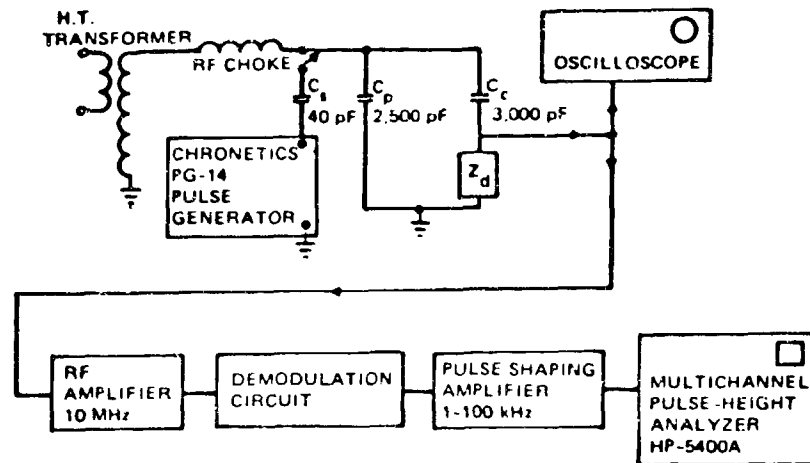

FIGURE 60. CIRCUIT FOR PARTIAL-DISCHARGE PULSE-HEIGHT DISTRIBUTION ANALYSIS WITH VARIABLE-RISE-TIME PULSE CALIBRATOR

amplifier and displayed on the cathode ray tube. Appropriate phasing of the oscilloscope trigger signal with the power frequency, or Z-axis modulation, can be used to blank out the leading-edge from the oscilloscope display.

Signals having a charge of less than one picocoulomb should be measured in a low-EMI screen room. High frequency partial discharge signals of less than one microvolt amplitude are easily lost when the background includes interfering signals of several microvolts. The power supply should be appropriately isolated.

Similarity of Partial Discharge and Calibrating Pulse. Valid readings from partial discharge measuring equipment are obtained only if frequency response of the detector and other circuit elements is broad enough to respond adequately to the frequency content of the partial discharges.

As the frequency content of actual pulses may extend into the range of 100 MHz, any corona detector operating over this frequency spectrum can be adequate for corona-level measurement. It is not a corollary, however, that the particular corona detector must be calibrated by an excitation pulse having a rise time corresponding to a frequency substantially below 100 MHz. Obviously,

in the case of a wide band corona detector, an ideal calibration requires that the rise time correspond to at least 100 MHz if the true response to a corona signal is to be simulated.

With modern pulse generators a calibrating pulse can be shaped to be similar to the pulse from a partial discharge. It is coupled into the detection equipment circuit through a standard quartz or vacuum capacitor.

It is important that the detection equipment be calibrated with respect to the test article, rather than just using a general-purpose calibrating technique. For example, capacitor test set-ups require much more sophisticated calibrating procedures than do set-ups having transformers and inductors because capacitors tend to attenuate their internal partial discharges. Resonant circuits should not appear between the calibrating unit and the test article.

Calibration and Partial Discharge Comparison. A partial discharge has frequency spectrum components up to 100 MHz (Figure 61).¹¹² The transit time for an avalanche discharge is between 0.3 and 20 nanoseconds, depending upon the voltage, gas, and spacing. This indicates that calibrating with a slow pulse of a few microseconds would not be representative of a partial discharge. For example, in measuring partial discharges within 5 microfarad capacitors, calibration with pulse rise times of 5×10^{-7} seconds produced good correlation with the capacitor partial discharges. When longer rise-time calibrating pulses were used, the calibrating pulse correlated poorly with the partial discharge pulse height.

Recommended Measurement System. Of the standard corona test equipment, the bridge detector has the best accuracy, is the most sensitive, and is easily operated. It supersedes the other detectors. Its major limitation is in measurements where square waves and frequencies greater than 60 Hz are used.

Test experience has shown that a universal detector and detector readout instrumentation is yet to be developed. Whereas the standard D1868 ASTM corona test methods are excellent for most commercial and 400 Hz sinusoidal power

112. W. G. Dunbar, "High Voltage Connections for Flight Vehicles", National Aerospace and Electronics Conference, Dayton, Ohio, 1974.

system testing, they have deficiencies for square waves and higher frequencies. RF antennas cannot be placed close enough to the test specimen. RF coils and capacitance detectors on the other hand must be placed close to the partial discharges because of their directionality.

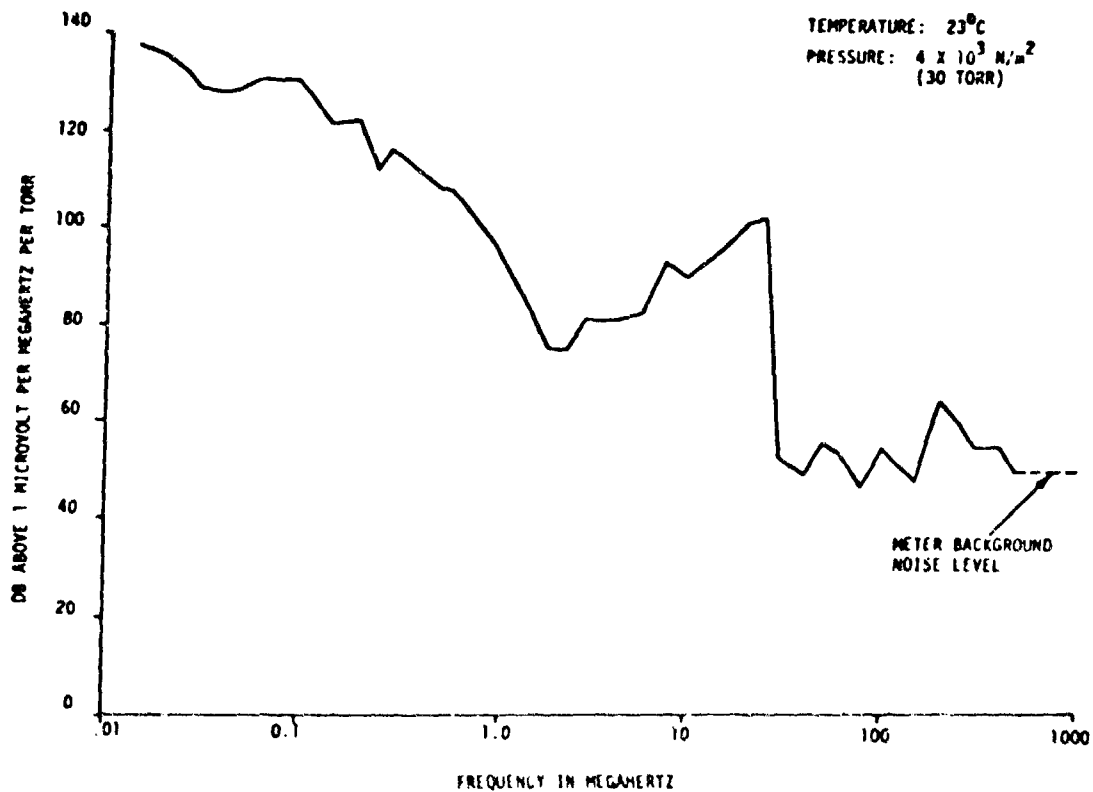

FIGURE 61. FREQUENCY SPECTRUM AT CORONA DISCHARGE

Standardized Measurement Technique, Method, or Procedure. Standardized measurement procedures have been developed by the ASTM committee for the forthcoming D9.12.12 standard method of measuring energy and integrated charge of partial discharges. The resulting procedures will be similar to ones which are being used by technicians working in the partial discharge area, and re-learning will be minimized. Also, use of the proposed ASTM standard procedure will assure that no important element has been left out.

The ASTM D9.12.12 standard partial discharge test method is described in Appendix C. This method can be used, with minimum modifications, for measurement of partial discharge pulses using dc, 60 Hz ac, and 400 Hz ac voltage sources. This standard method cannot be used without modification for measurement of partial discharges where the system frequency is higher than 400 Hz, square waves or ac plus dc.

5.4 Performance Testing. Destructive and non-destructive tests are used for the qualitative evaluation of electrical/electronic parts and insulation. In the following text, the expression "parts" refers to electrical components such as resistors, capacitors and coils.

5.4.1 Testing and Detection. Generally, the test philosophy for electronic parts and hardware should be that sample flight parts as well as engineering, development, prototype and qualification equipment should be thoroughly and extensively tested and stressed repeatedly to establish the margin of the design. Equipment intended for qualification, should first be tested to acceptance levels to verify workmanship and to identify infant-mortality failure causes. Flight equipment should never be subjected to repeated electrical tests. One test of qualified flight equipment should be sufficient to verify workmanship and expose infant-mortality conditions. Cumulative electrical stress can, on the other hand, jeopardize its operating life.

5.4.2 Equipment Testing. A partial discharge detector probe can usually be located near unshielded equipment; otherwise it is necessary to "build in" the detector. Some devices such as photomultipliers, are good detectors in themselves and require no additional detectors when tested. The normal operating characteristics of items being tested should be thoroughly understood so that off-normal operation can be recognized. Partial discharges, when present, will sometimes be superimposed upon normal waveshapes.

5.4.3 High Voltage Testing. AC high voltage testing is normally conducted to establish voltage endurance as a function of time. AC testing is usually a go/no-go type, with voltage being raised to a specified value with samples that break down within a specified time being rejected.

DC high voltage testing procedures usually differ from ac procedures in that leakage current is measured as voltage is raised. Current varying linearly with voltage indicates the equipment is in good condition. As the breakdown point is approached, the leakage current increases at a higher rate, followed by an avalanche current. With some newer insulations, this knee in the current plot is almost a right angle bend, breakdown being reached about when the first sign of the knee appears. The rate of application of voltage rise also affects the breakdown point.

Reproducible measurements are hard to get in very high-temperature high voltage testing because insulators supporting the equipment and wiring must be cooled to keep them from becoming semiconducting. This creates temperature gradients in the chambers, and even though the gas in the chamber is at constant pressure, its density will vary inversely with its temperature. The partial discharge initiation voltage is affected by gas density, so ambiguities are introduced into the susceptibility of the different parts of the high voltage circuit. Careful design of the test, complete temperature instrumentation, and detailed analysis of test results is required for obtaining valid results.

5.4.4 Parts Tests. A part that is to be evaluated for partial discharges should be completely insulated and placed within the configuration in which it will be in the aircraft. Pre-test processing should include cleaning and potting of parts, and the cleaning and solder-balling of the terminations. For example, if the part is normally on a conformally coated circuit board, then the test article should be assembled in the same way. The spacing between the part and the ground plane should be the same as it will be in the final application. This includes all upper, lower and side ground planes which will limit the field gradients and establish the pressure-spacing dimensions for partial discharges.

The altitude chamber feedthroughs and connections must be free of sharp corners and edges to prevent corona from the high voltage gradients present at such points. There should be no gaps, pockets or outgassing materials associated with the chamber feedthroughs or connections to the part being tested.

These outgassing parts can create localized zones of higher pressure near the test article, and raises corona initiation voltage for pressure greater than 100 Pa. The test fixture using one of the most important parts of the test must be in its exact position during test installation. All connections and interconnections must be solid, free of outgassing, and corona-free. The best corona sensors for testing parts, insulated electrodes, and the gaseous break-down between fixed electrodes are directly coupled capacitors, series resistors, or RF coils with the bridge corona detector circuit shown in Figure 59. These sensors are simple, easily connected, and accurate.

5.4.5 Circuit Tests. Circuits consisting of simple assemblies of parts can be tested in the same way as parts. More complex circuits require special tests or additional detectors. An example of a simple circuit is a voltage divider network or a voltage multiplier. A more complex circuit would be a power supply, a filter circuit, or the high-voltage electronic system.

5.4.6 System Tests. A high voltage circuit within an electrical/electronic system is difficult to test and analyze unless the individual high voltage circuits are instrumented as just described. Often detection devices must be placed as near as possible to the high voltage elements. Applicable detectors for this purpose are RF coils, capacitors, antennas, and ultrasonic detectors.

All these detectors will sense external RF electrical noise as well as partial discharge signals, so it is necessary to monitor the power return or common-point ground for noise. This noise, in coincidence circuits is then used to identify and eliminate those observed pulses that are not true partial discharges. Oscillograms of corona and noise signals are shown in Figure 62.

5.5 Facility and Environment. High voltage airborne systems must often be tested in a temperature-controlled vacuum chamber, which of course must be designed to be corona-free. Corona sources that have been encountered in environmental test chambers include:

- a. pressure gauges
- b. heater panels
- c. light sources

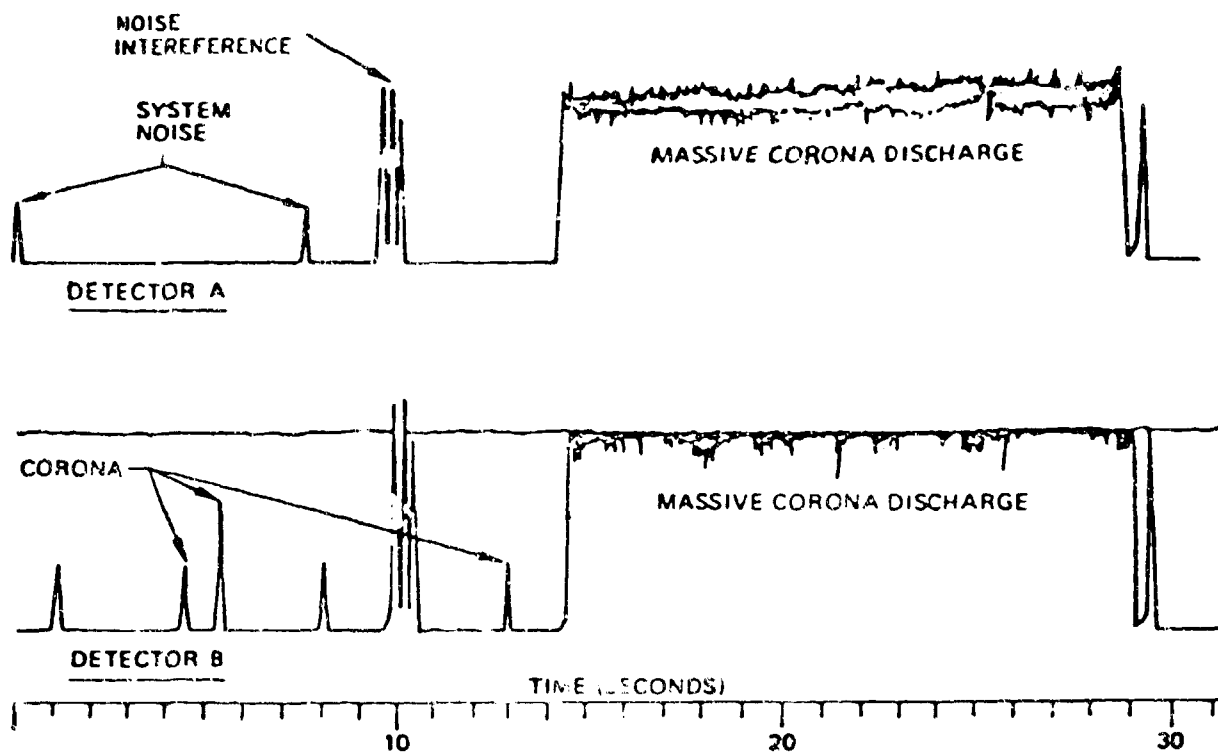

NOISE AND CORONA DISCHARGES RECORDED ON AN OSCILLOGRAPH

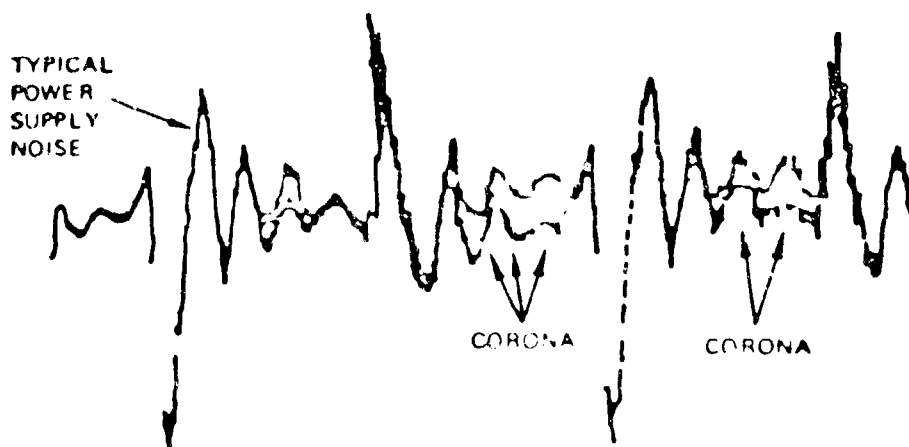

CORONA DETECTED BY REF COIL DISPLAY ON FIBER OPTICS RECORDER

FIGURE 62 NOISE AND CORONA RECORDINGS

d. wiring, cabling, and connectors

Environmental test chambers can be evaluated with the same corona detection circuits and detectors as are used for airborne parts and circuits. The detectors must be capable of operating at pressure less than $4. \times 10^3 \text{ N/M}^2$ (30 torr). They should respond to frequencies up to 100 MHz, should be omnidirectional, and should not contaminate the chamber.

5.5.1 Contamination. The test chambers can be contaminated by foreign gasses, dust particles, oxides, salts, and out-gassing products. Helium, argon, and neon effectivity reduce the partial discharge initiation voltage. Test chambers should be purged to eliminate contaminating gases unless of course the tested unit generates or releases such gases. Helium and hydrogen will leak through ceramic and glass seals of pressurized units.

Dust particles can intensify local dielectric stress, develop tracking, and eventually form a point electrode. Oxides and salts deposited by handling during assembly, storage, transportation, or operation will degrade insulation materials. They also alter the surface composition of the electrodes.

5.5.2 Life Testing. Twenty percent overvoltage will shorten insulation life to about one-fourth of normal (Figure 57). However, in accelerated life tests the insulation must operate free of partial discharges at both normal and over-voltage levels.

Experience has shown that incorporating the following elements into a life test contributes to the development of valid test data.

- a. Partial discharge detection readout should be monitored continuously by electronic means.
- b. Temperature cycling is required to produce the thermo-mechanical stresses that may enhance partial discharge formation. The temperature should be cycled from minimum to the maximum extreme specified for the equipment at least five times. Each cycle should include "soak" time at each temperature extreme to permit the material

components to thermally stabilize. These tests may be performed in either air or vacuum.

- c. If partial discharges become more frequent with increasing temperature, more temperature cycles should be performed to determine whether the partial discharges increased because of temperature or time.
- d. The gas pressure should be kept within the operating range of the tested equipment but at a point corresponding to the closest approach to the Paschen law minimum or highest operating altitude pressure.
- e. After completion of the temperature cycling, the high voltage should be turned off and on five times at 5 minute intervals. The off time should be less than 15 seconds. During the power turn-on the partial discharge detectors should be operating and their output should be recorded. An increase in the magnitude and/or quantity of impulses for each on-off cycle indicates that insulation is deteriorating and should be replaced.
- f. Life testing should follow the temperature cycling, and should continue for at least 25 percent of the expected life of the equipment.

6. QUALITY ASSURANCE PROVISIONS, SPECIFICATIONS AND STANDARDS

The most reliable tests are those which best simulate service conditions. For this reason, valid testing of the durability of materials with respect to long-time breakdown processes such as partial discharge erosion and treeing are time consuming. Attempts to accelerate such tests are unreliable since materials do not respond linearly to changes in test severity. Hence, dependable information can often be obtained only with tests extending over months or years.

A word of caution is needed about the testing for phenomena involving sparking in an altitude chamber. Sparking may not occur in the chamber, but will occur in the equipment when in service because there are free electrons in the airplane environment, but not in the test chamber. A radioactive source of ionizing radiation such as polonium should be placed near the equipment under test in the altitude chamber to insure a supply of electrons in the critical gap volumes. Polonium is recommended because it is not as hard to handle as other gamma sources like cobalt 60.

6.1 Specifications and Standards. Electrical specifications and standards have been well developed for commercial high voltage components and equipment, but not so completely developed for the military counterparts. Agencies that have developed high-voltage specifications and standards are:

- o National Electrical Manufacturers Association
- o Underwriters Laboratories
- o American Standards Association
- o Institute of Electrical and Electronic Engineers
- o U.S. Department of Defense (military specifications and standards)
- o Electrical Equipment Manufacturers

6.2 Military Specifications and Standards. Military specifications and standards applicable to airborne high-voltage components and equipment are listed in Tables 26 through 29.

6.3 Safety. A potential personnel shock hazard results from the "recovery charge phenomenon," where a latent charge builds up in any capacitor-like structure after it has been discharged. Therefore, high voltage connector protective caps having integral shorting contacts should be installed on all open high voltage connectors when not in use. These connector protective caps should be installed on each high voltage cable and equipment prior to shipment and should remain on until installation is complete.

TABLE 26
CAPACITORS

<u>Specification Number</u>	<u>Title</u>	<u>Highest Voltage Rating</u>	<u>Highest Altitude</u>
MIL-C-11693	Capacitors, Feedthrough, RFI, AC and DC	1200 Vdc	4
MIL-C-19978	Capacitors, Fixed, Plastic (Or Paper Plastic) Dielectric	1000 Vdc	4
MIL-C-39006	Capacitors, Fixed, Electrolytic, Tantalum	630 Vdc	7
MIL-C-39014	Capacitors, Fixed, Ceramic, Dielectric	1500 Vdc	5
MIL-C-39022	Capacitors, Fixed, Metalized, Paper-Plastic Film or Plastic Film Dielectric, AC & DC	600 Vdc	5
MIL-C-55514	Capacitors, Fixed, Plastic (or Metalized Plastic) Dielectric, DC	600 Vdc	5
MIL-C-83439	Capacitors, Fixed, Feedthrough, EMI, AC & DC	400 Vdc	3

1 Altitude Code

<u>Code</u>	<u>Highest Applicable Altitude</u>
1	Sea Level
2	50,000 Ft.
3	70,000 Ft.
4	80,000 Ft.
5	100,000 Ft.
6	110,000 Ft.
7	150,000 Ft.

TABLE 27
CONNECTORS

<u>Specification Number</u>	<u>Title</u>	<u>Highest Voltage Rating</u>	<u>Higest Altitude</u>
MIL-C-005015	Connectors, Electric "AV" Type	3,000 Vrms	1
MIL-C-12520	Connector, Plug and Receptacle (Electrical, Waterproof) and Accessories, General Specification for.	3,000 Vrms	1
MIL-C-26482	Connectors, Electrical, Circular, Miniature, Quick Disconnect, Environment Resisting	1,000 Vrms 450 Vrms	1 3
MIL-C-26500	Connectors, General Purpose, Electrical, Miniature, Circular, Environment Resisting, 200°C Ambient Temperature	600 Vrms 300 Vrms 300 Vrms	1 3 6
MIL-C-26518	Connectors, Electrical, Miniature, Rack and Panel Environment Resisting, 200°C Ambient Temperature	600 Vrms 300 Vrms 300 Vrms	1 3 6
MIL-C-81511	Connector, Electric, Circular, High Density, Quick Disconnect, Environment Resisting, Specification for	1000 Vrms 450 450 450	1 2 3 6
MIL-C-83723	Connector, Electric, Circular, Environment Resisting General Specification For	3000 Vrms	1
MIL-C-38999	Connectors, Electrical, Circular, Miniature, High Density, Quick Disconnect, Environment Resistant, Removable Crimp Contacts	900 Vrms	1

TABLE 28
WIRE AND CABLES

<u>Specification Number</u>	<u>Title</u>	<u>Highest Voltage Rating</u>	<u>Highest Altitude</u>
MIL-C-915	Cable, Electrical, Special Purpose, General Specification For	3,000 Vrms	1
MIL-C-3432	Cable and Wire, Electrical (Power and Control); Semi-Flexible, Flexible, and Extra Flexible, (300 and 600 volts)	600	1
MIL-W-5086	Wire, Electrical, 600 Volt, Copper, Aircraft	3,000	1
MIL-W-7072	Wire, Electric, 600-Volt, Aluminum, Aircraft, General Specification For (ASG)	600	1
MIL-C-7078	Cable, Electric, Aerospace Vehicle, General Specifications	600	1
MIL-W-7139	Wire, Electrical, Polytetrafluoroethylene-insulated, Copper, 600-Volt	600	1
MIL-W-8777	Wire, Electrical, Silicone Insulated, Copper, 600 Volt, 200 Deg. C	600	1
MIL-C-13777	Cable, Special Purpose, Electrical, General Specifications	600	1
MIL-W-16878	Wire, Electrical, Insulated, High Temperature	3,000	1
MIL-C-21609	Cable, Electrical, Shielded, 600-Volt	600	1
MIL-W-22759	Wire, Electric, Fluorocarbon-Insulated	1,000	1
MIL-W-25038	Wire, Electrical, High Temperature and Fire Resistant, Aircraft	600	1
MIL-C-27072	Cable, Special Purpose, Electrical Multi-conductor	3,000	1
MIL-C-55021	Cable, Twisted Pairs and Triples, Internal Hook-up	3,000	1
MIL-W-81044	Wire, Electric Cross-Linked Polyalkene-Insulated Copper	600	1
MIL-W-81381	Wire, Electric, Polyimide-Insulated, Copper and Copper Alloy	600	1

TABLE 29

EQUIPMENT

<u>Specification Number</u>	<u>Title</u>	<u>Highest Voltage Ratio</u>	<u>Highest Altitude</u>
W-C-375	Circuit Breaker, Molded Case; Branch-Circuit and Service	600 Vrms	1
MIL-C-17361	Circuit Breaker, Air, Electric, Insulated Enclosure (Shipboard Use)	500 Vrms	1
MIL-C-17587	Circuit Breakers, Air, Electric, Open Frame, Removable Assembly (Shipboard Use)	500 Vrms	1
MIL-F-15733	Filters, Radio Interference	600 Vdc 250 Vrms	2 2
MIL-T-27	Transformers and Inductors (Audio, Power, and High Power Pulse), General Specification for	580 Vrms	3
MIL-C-15305	Coil, Radiofrequency, and Transformers, Intermediate and Radio frequency, General Specification for	200 Vrms	3
MIL-STD-451	SAFETY, Requirement 1, Paragraph 5, Electrical		

7. POSSIBLE PROBLEM AREAS AND SUGGESTED SOLUTIONS

High voltage systems are plagued with annoyances that are unnoticed in lower voltage systems. Some of the more subtle annoyances are listed below.

7.1 Debris. Small dielectric flakes or chips lodged or laying on the surface or edge of a coil will align themselves with the electric field. Secondly, they will be charged to the same potential as the surface to which they are attached acting as a point on the surface. This will decrease the utilization factor of the gas or oil and be a cause of excessive corona and eventual breakdown. Thorough cleaning with high pressure air and inspections are the cure for this problem.

7.2 Mechanical Stress. Terminations should be designed so mechanical stress points are minimized on the insulating boards. This can be accomplished by molding the terminal in a solid insulating material that is attached to the board, or by placing metal spacers with flanges through the board. The metal spacers not only reduce the mechanical stress but also increase the surface utilization factor between the flange edges.

7.3 Flexible Wiring. High voltage extra flexible wiring is acceptable in some limited cases. It should be used only as a last resort. When used, it should be guided from terminal to terminal to eliminate the probability of the wire insulation intermittently touching other surfaces containing higher or lower voltage circuits.

7.4 Manufacturing Cleanliness. No one can overstress the need for manufacturing cleanliness. When papers, films and other cleaned surfaces are handled, gloved hands should be mandatory. Slight amounts of oils or acids may be the cause of an improper bond or encapsulation. Any paper, cloth, film or other dielectric material is suspect and should be inspected by material, shop fabrication personnel, or engineering. Also smoke emitting objects in material's fabrication shops may contaminate the dielectric.

7.5 Mold Release Agents. Silicone products may contaminate certain epoxies, urethanes, and other insulating materials. Compatibility and contamination of materials for bonding purposes should be investigated prior to fabrication. When there is an incompatibility, then personnel working with the contaminates should be properly informed of the condition and take precautions to avoid contamination.

7.6 Similarity. Too often materials and designs are used because they have similar characteristics. Similarity ends at the last pour of a batch, the last section of the roll, and the last fabricated part by a skilled craftsman. New personnel must be informed of the hazards and precautions, the application and handling of parts and materials, and the inspection, calibrating, and testing of all jigs, tools, and assemblies in order to produce an excellent product.

7.7 Testing. Flaws in outer surfaces and between a single conductor and a surface can be visually inspected. When a coil, circuit, or multiple conductor assembly is tested, the test must be designed to include the detection of imperfections between coil layers, circuit parts, and assembly layers. This implies that the total assembly must be energized in such a way that all over-stressed electrical parts will be detected. An over-voltage test and/or over-frequency tests are two methods for testing.

7.8 Environment and life. Most high voltage circuits and parts will be installed in enclosed pressurized containers. This will reduce the probability of thermal shock, but not temperature extremes. Testing an insulation in a small dish is inadequate. Fabricated assembled parts and circuits should be assembled per specification inside the container and tested through the temperature extremes with all circuits normally energized. Five to nine cycles are recommended. Pre-environmental tests and post-environmental tests should include corona, dissipation factor, and insulation resistivity and a visual inspection for breaks, tears, and deformation. Any significant changes in appearance or electrical characteristics are reason for further testing and/or modification prior to qualification and life testing.

7.9 Tabs. Coil winders and circuit assemblers often place small tabs on wires and parts for identification and installation purposes. When these coils and circuits are to be encapsulated, film tape tabs such as mylar adhesive may be a cause for a built-in gas pockets or voids. These voids may be a place for the initiation of partial discharges and eventual voltage breakdown. When tabs are required, make them of porous materials that are compatible and easily wetted with the encapsulant.

7.10 Spacers. Spacers between two energized encapsulated units must be near void-free and have smooth or rounded surfaces to reduce tracking susceptibility across the spacer surface. The two dielectrics will reduce the stress across the spacer and the available charging current but they will not eliminate the problem. The spacer surface should be designed as though the voltage at the dielectric surfaces was from base electrodes not dielectrics.

7.11 Coatings. Coated metal surfaces have higher breakdown voltage characteristics than uncoated surfaces provided the correct coating material is applied. Some coatings do not bond well, flake and reduce the electrical stress capability of the two electrodes. Others may have pin holes and voids or blisters which will also cause flaking. Coatings must be evaluated with proper materials under identical environmental and electrical stress conditions to be fully qualified.

7.12 Determining Corona Limitation Voltage. The corona initiation voltage (CIV) of an electrical apparatus can be determined when the design parameters and the applicable Paschen-law curve are known. The particular Paschen curve used depends on the type of gas the corona would occur in, the temperature of the gas, and the surface condition of the electrodes.

A comparison of Paschen curves for different possible gases is given in Figure 63. It is not necessary to use any of these. If the temperature exceeds 500°F, special Paschen curves must be used. Several curves for insulated and non-insulated wires are given in Reference 113 and 114.

113. "Calculating Corona Critical Field," prepared by W. G. Dutton, DEAF 216-1, The Electric Company, 1966.
114. W. G. Dutton, "Corona Limits of Insulated Airplane High Temperature Wire," Final Technical Report on Corona, Natick AF 11-73, December 1966.

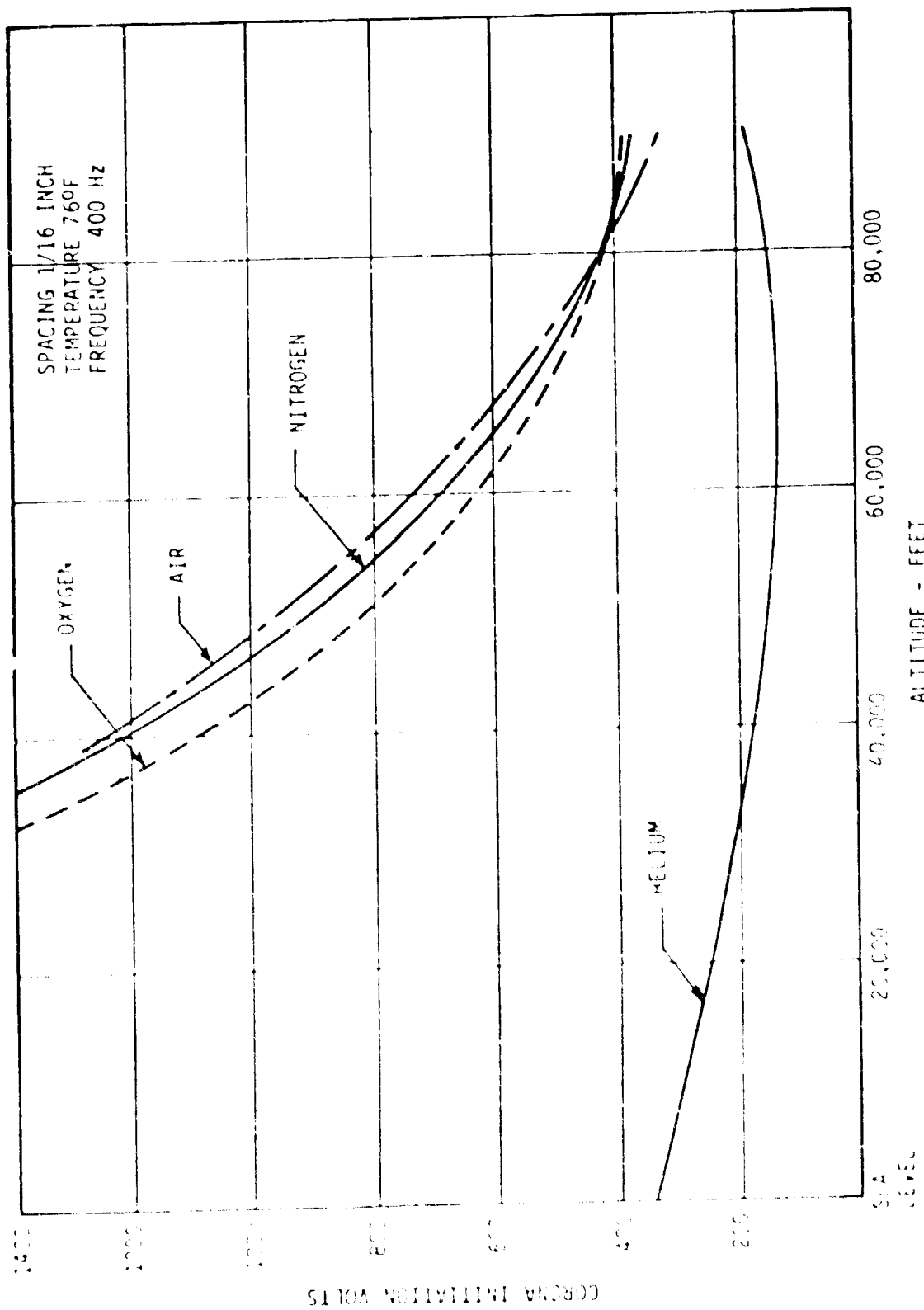

FIGURE 63. CTV OF COMMON GASES

8. CONCLUSIONS

This design guide is intended to be used by designers of compact, high density, high voltage equipment. Formulas and empirical equations are shown for typical high voltage electrode configurations found in electrical equipment. A designer using these empirical formulas and the field plotting methods shown can locate maximum field stresses within electrical insulation systems. Then the proper dielectrics can be selected for the application.

Design configurations and test methodology are described. Each design must be configured within the space and weight allocations. Thus these configurations are only guidelines. Likewise tests should be accompanied by detailed test procedures before a high voltage design is recommended for fabrication.

APPENDIX A
FIELD PLOTTING METHODS

A1. Freehand Field Plotting. Freehand field plotting using "curvilinear" squares is shown in this paragraph. These squares, generated by constant-potential and constant-field lines, have the following properties:

- All sides intersect at right angles.
- All "squares" can be subdivided (by an equal number of equipotential and orthogonal flux lines) into smaller squares, which more closely approach true squares as the subdivision is continued.
- Every curvilinear square has the same capacitance, and the flux per square is proportional to the potential difference across it.
- Field lines leave the conductor at right angles.

If the region is not completely enclosed by known boundary conditions, the designer needs to be sure that the field divides properly as infinite distance is approached. Combined fields from two or more sources are best dealt with by drawing each one separately and then superimposing. Most designs have symmetry that can be used advantageously to reduce the work required.

Each trial suggests changes that must be made to determine the final shape of the field. The correctness of the final field plotted by this cut-and-try process is tested by the following criteria.⁹²

- Do the field lines and equipotential lines intersect everywhere at right angles?
- Are there curvilinear squares everywhere in the dielectric media, or do they become so when subdivided?

Examples of freehand flux plotting are shown in Figures A-1 and A-2. Accurate freehand plotting techniques are found in References 6, 100, 101, 102, and 115 through 119. These references, though old, were used successfully for four decades before computers were available. Many designers continue to use this technique. A block diagram of a computer program for field plotting is outlined in Appendix B.

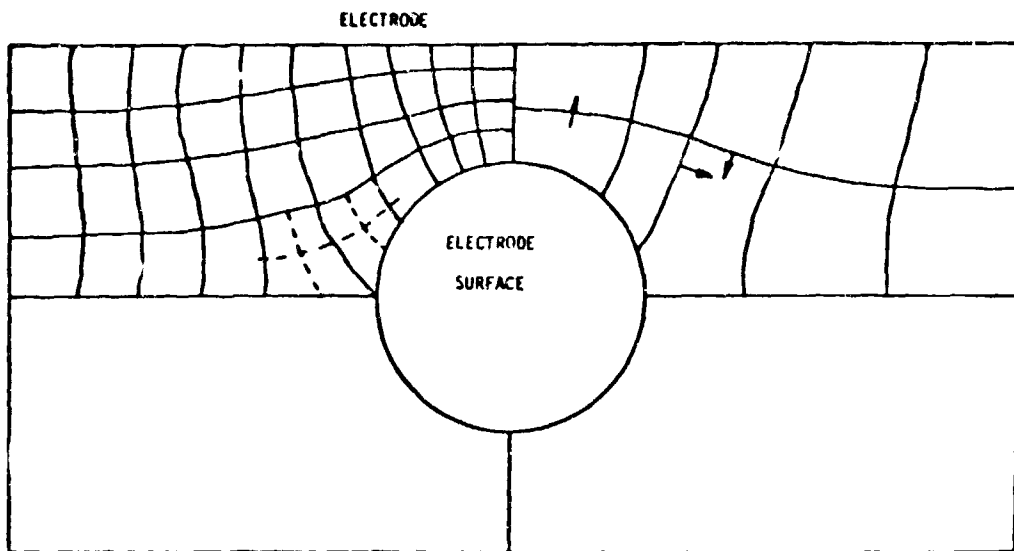

FIGURE A1. FREEHAND FIELD MAPPING

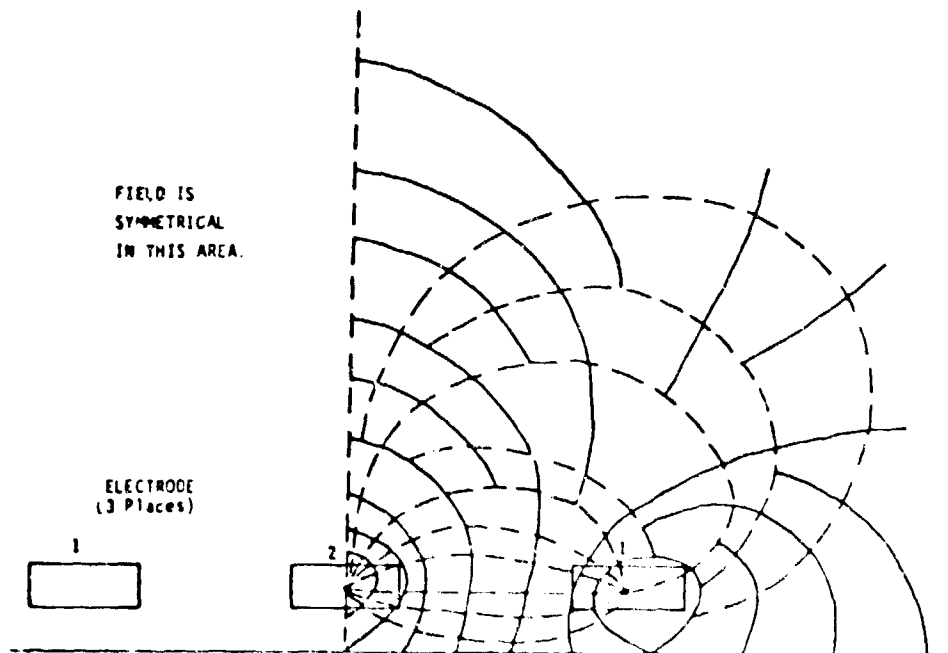

FIGURE A2. FREEHAND FIELD MAPPING

A2. Resistance Paper. A technique for mapping fields uses resistance paper, also called teledeltos paper. This method is rapid, and the plotted equipotential lines resemble a freehand field plot. Non-uniform fields generated by multiple electrodes are easily handled. Furthermore, the designer can easily change the electrode and dielectric shapes to get the highest utilization factors.

The general technique is to represent the electrode on the resistive paper with silver conducting paint. The shape and spacing of the electrodes must be scaled accurately. For best results, space the high and low-potential electrodes about 9 to 12 inches apart. Next, apply a voltage between the conducting surfaces, voltmeter and points of equal potential on the resistance paper are mapped with a terminal connected to a dull-pointed probe (Figure A-3).

In plotting the equipotential lines the voltage between electrodes is set at a convenient value, say 10 volts. The probe is placed on the paper between the electrodes, preferably where the field gradient is highest, and moved until a given voltage, say 4 volts, is read. The spot is recorded with a dot using a non-conducting ink or pencil lead. The probe is moved laterally about one inch and the same 4 volts is sought. Repeating this process for additional points and at other voltages produces points through which equipotential lines can be readily plotted (Figure A-4).

Mathematically, the following has been accomplished.

- The electric field within the paper satisfies the equation

$$\nabla t \cdot \bar{E} = \nabla t \times \bar{E} = 0 \quad (A-1)$$

where $\nabla t = \bar{a}_x \frac{\partial}{\partial x} + \bar{a}_y \frac{\partial}{\partial y}$ (A-2)

- A solution to (1) is a potential function $\phi(x, y)$ in the form $\bar{E}(x, y) = -\nabla t \phi(x, y)$, where $\phi(x, y)$ is the point-to-point voltage measured with the meter.

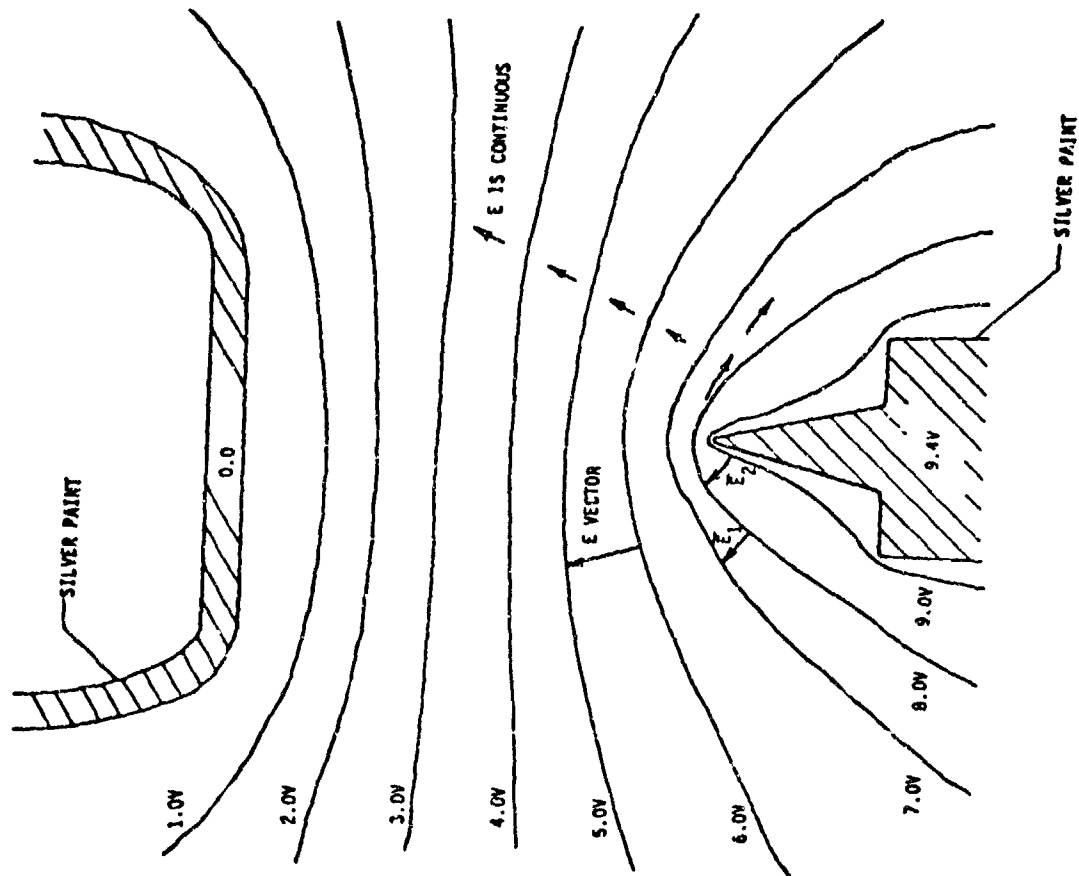

FIGURE A4. PLOT OF EQUIPOTENTIAL LINES USING RESISTANCE PAPER

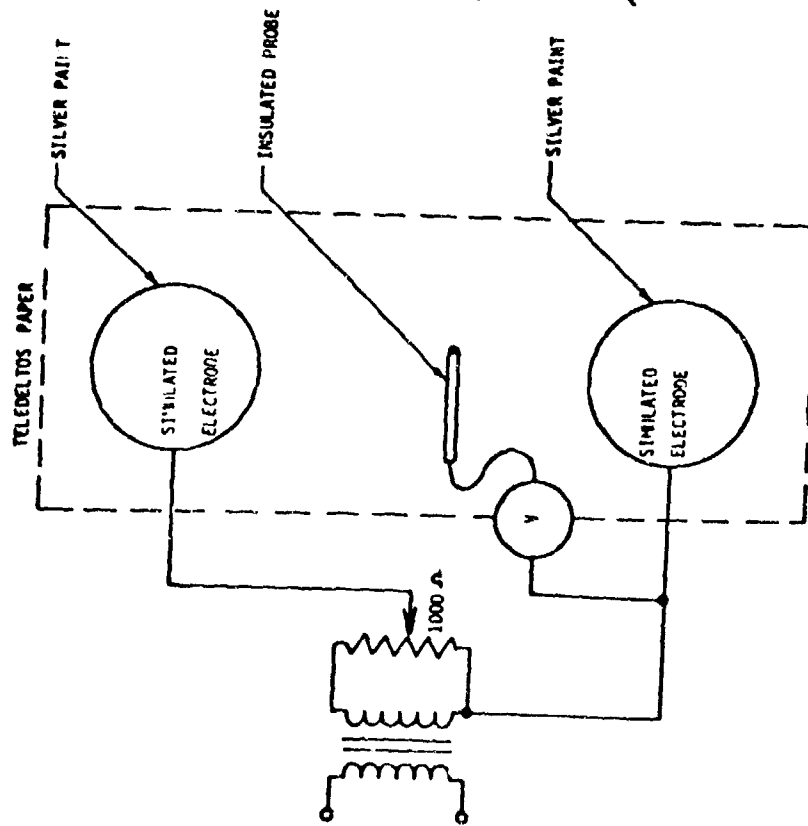

FIGURE A3. RESISTANCE PAPER PLOT CIRCUIT

- The current density within the paper, \bar{J} (ampere/meter²) and \bar{E} is almost linear in the form $\bar{J}(x, y) = \sigma \bar{E}(x, y)$ where σ is the conductivity of the paper (ohms/meter²).

The field lines, if required, can be drawn freehand by using curvilinear square principle, or can be developed by using a conjugate electrode arrangement. Freehand flux plotting is probably easier and quicker. The conjugate electrode approach requires that the electrodes be placed along a selected field line, and that the current flow be restricted along the former electrodes by cutting out the electrode surfaces.

The field lines, once located can be superimposed upon the equipotential lines for the full plot, as shown in Figure A-2.

A3. Other Field Plotting Techniques. Other field plotting devices include electrolytic troughs, rubber membranes, and mathematical analyses.

Electrolytic Trough⁶. A large tank containing a weak solution of copper sulphate is the electrolyte and copper plates are the electrodes. A nickel or platinum wire probe on a pantograph is used to seek the equipotential lines between the electrodes. The detector is Wheatstone bridge having probe and electrodes on its two arms and a calibrated potentiometer as the other arm (Figure A-5).

Rubber Membrane. A thin rubber membrane evenly stretched over a frame can be used to plot fields. The appropriately scaled electrodes protrude upward for positive potentials and downward for negative potentials; the frame represents zero potential. The profile gives an exact replica of the equipotential lines.

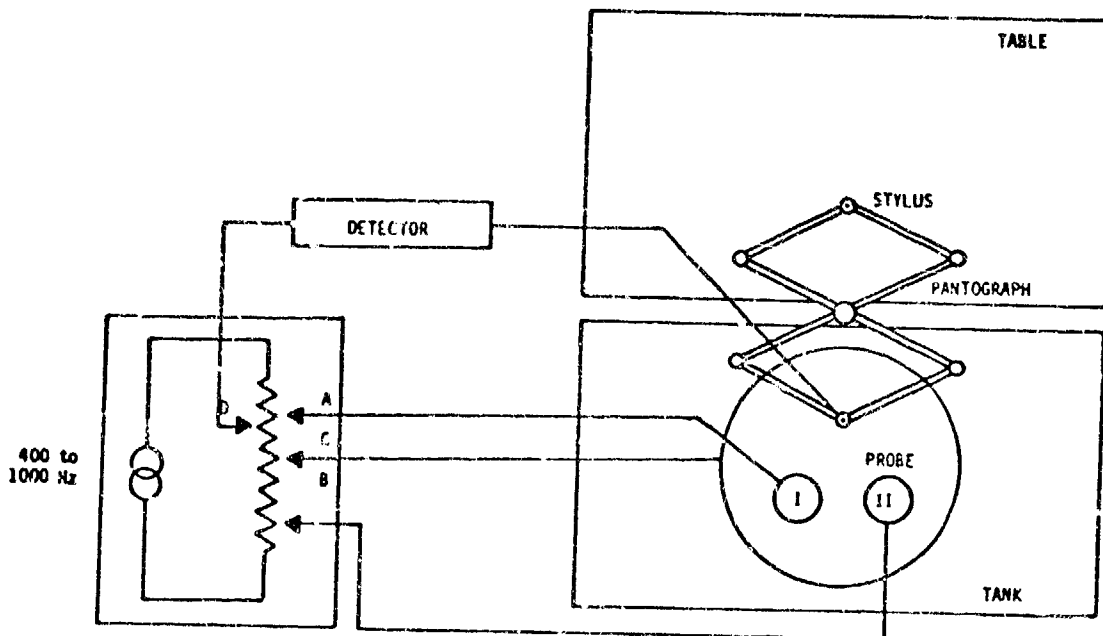

FIGURE A5. BLOCK DIAGRAM OF ELECTROLYTIC TROUGH

115. J.F. Calvert and A.M. Harrison, "Graphical Fluid Mapping," *Electric Journal*, Vol. 25, March 1928.
116. A.D. Moore, "Mapping Magnetic and Electrostatic Fields," *Electric Journal*, Vol. 23, 1926, p. 355-362.
117. A.R. Stevens, "Fundamental Theory of Fluid Plotting," *General Electric Review*, Vol. 29, November 1926, pp. 794-804.
118. R.W. Wieseman, "Graphical Determination of Magnetic Fields-Practical Applications," *AIEE Trans.*, Vol. XLVI, 1927, p. 141.
119. H. Poritsky, "Graphical Field Plotting Methods in Engineering," *AIEE Trans.*, Vol. 57, 1938, p. 727.

APPENDIX B

INTRODUCTION

There are several numerical solutions to the Laplacian equation:

$$\nabla^2 \phi = \frac{\partial^2 \phi}{\partial x^2} + \frac{\partial^2 \phi}{\partial y^2} + \frac{\partial^2 \phi}{\partial z^2} = 0 \quad (B1)$$

Before high-speed computers with large memories became available, the usual numerical solutions were not practical because of the many computations required.

Galloway, Ryan, Eng, Scott, and Mattingly¹²⁰ of Reyrolle Parsons Ltd., England, have developed computer programs using finite-difference equations, and the Gaussian forward-elimination and back-substitution for solution of these finite difference equations (B1, B2, B3, B4). This system of programs is easily adaptable to problems in two dimensions, or three dimensions with one axis of symmetry.^{121, 122, 123}

A charge simulation method adaptable to computer solutions was presented by Singer, Steinbigler, and Weiss.¹²⁴ Charge simulation methods do not need large computer storage and long computation times. Using Gauss' theorem, Misaki, Yamamoto, and Itaka determined the electrostatic potential field distribution for a three dimensional asymmetric problem in circular cylindrical coordinates.¹²⁵

Finite Difference Technique. The numerical method presented here is characterized by a representation of the electrostatic potential field distribution with discrete nodal points. Finite difference equations are determined for each nodal point. The composite of all the finite difference equations is solved by an iteration technique called successive over-relaxation.¹²⁶ This yields the electrostatic potential for each nodal point. This method of solution has been used by Storey and Billings.^{127, 128} It is adaptable to field problems with single or multidiellectrics, several conductors of different potential, to two and three dimensions and in cartesian or circular cylindrical coordinate systems.

To use finite difference equations to solve the Laplacian equation, the field problem is overlayed with a fine grid. The spacing between grid lines

making up the grid can vary. For accuracy and resolution, the grid lines are spaced closer together at the specific areas of interest in the field and wider apart elsewhere. Conducting surfaces and dielectric interfaces can be represented by grid lines; by diagonals between nodal points, or by triangulation of the grid lines.¹²⁹ Figure B-1 shows an example problem.

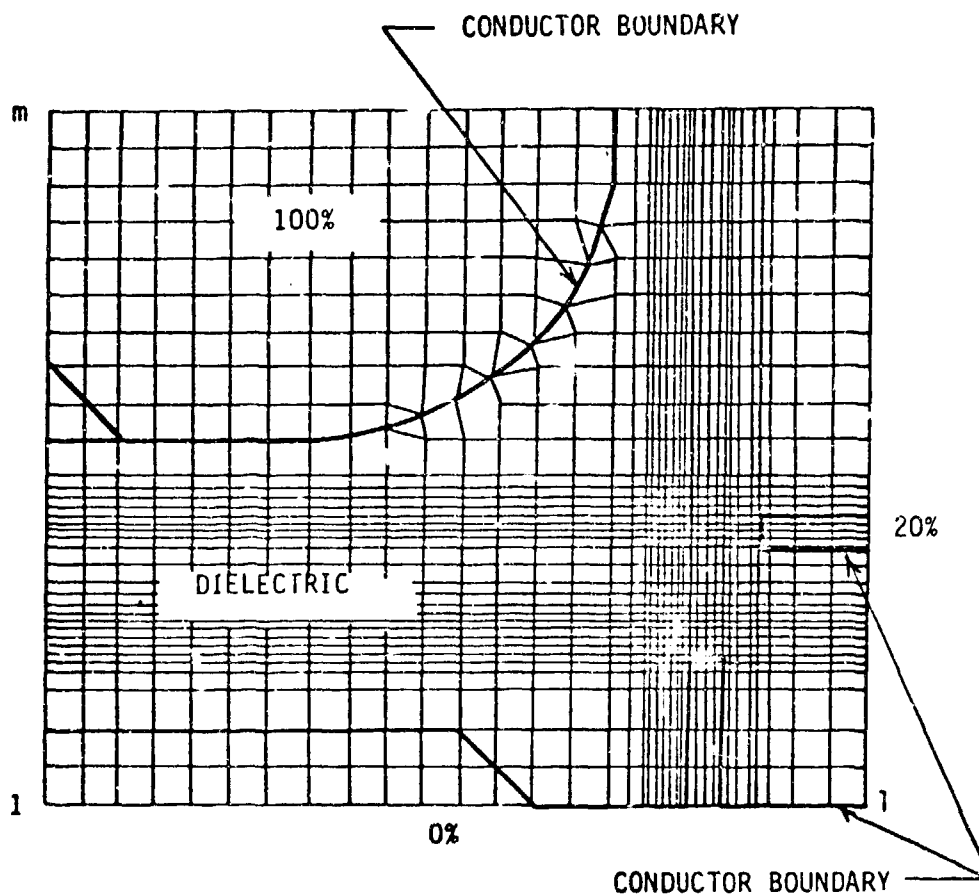

FIGURE B-1. FINITE DIFFERENCE GRID. POTENTIALS GIVEN AS PERCENTAGE OF NOMINAL TEST VOLTAGE

There are present methods of automatic grid generation which are a great aid to triangulation fitting.

Depending on the configuration of the problem, the optimal finite difference equation may be called out for use in the program. The finite difference equations are derived from Taylor's series expansion. Figure B-2 shows a

general 2-dimensional irregular star which represents one node on the grid and its immediate surrounding nodal-points. Using Taylor's series expansion in the x direction at the node (x, y) , yields:

$$\phi(x-1, y) = \phi(x, y) + h_{xx} \frac{\partial \phi}{\partial x} + \frac{h_{xx}^2}{2!} \frac{\partial^2 \phi}{\partial x^2} + \dots \quad (B-2)$$

$$\text{and } \phi(x+1, y) = \phi(x, y) - h_x \frac{\partial \phi}{\partial x} + \frac{h_x^2}{2!} \frac{\partial^2 \phi}{\partial x^2} - \dots \quad (B-3)$$

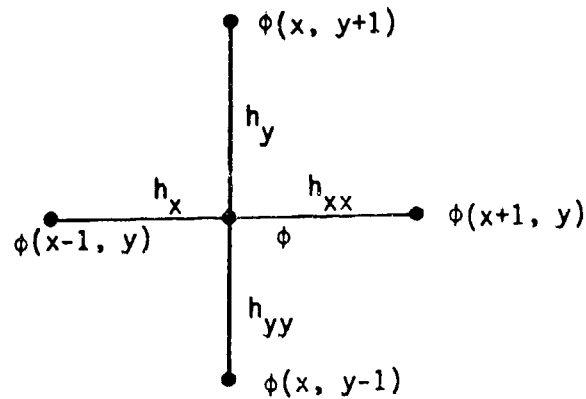

FIGURE B-2. IRREGULAR STAR IN TWO DIMENSIONAL CARTESIAN CO-ORIGINATES

Adding equation 2 multiplied by h_x to equation 3 multiplied by h_{xx} gives:

$$h_x \phi(x+1, y) + h_{xx} \phi(x-1, y) = (h_x + h_{xx}) \phi(x, y) \quad (B-4)$$

$$+ \frac{h_x h_{xx}}{2} (h_x + h_{xx}) \frac{\partial^2 \phi}{\partial x^2}$$

Solving for $\frac{\partial^2 \phi}{\partial x^2}$, and similarly for $\frac{\partial^2 \phi}{\partial y^2}$, then

Substituting into equation (1) yields

$$\left(\frac{1}{h_x h_{xx}} + \frac{1}{h_y h_{yy}}\right)\phi(x, y) = \frac{h_x \phi(x+1, y) + h_{xx} \phi(x-1, y)}{h_x h_{xx} (h_x + h_{xx})} + \frac{h_y \phi(x, y+1) + h_{yy} \phi(x, y-1)}{h_y h_{yy} (h_y + h_{yy})} \quad (B-5)$$

which is the finite difference form of the Laplacian equation in two-dimensional Cartesian co-ordinates.

Referring to Figure B-3, the three dimensional finite difference form of the Laplacian equation in Cartesian co-ordinates is:¹²⁷

$$\left(\frac{1}{h_x h_{xx}} + \frac{1}{h_y h_{yy}} + \frac{1}{h_z h_{zz}}\right) \phi(x, y, z) = \frac{h_x \phi(x+1, y, z) + h_{xx} \phi(x-1, y, z)}{h_x h_{xx} (h_x + h_{xx})} + \frac{h_y \phi(x, y+1, z) + h_{yy} \phi(x, y-1, z)}{h_y h_{yy} (h_y + h_{yy})} + \frac{h_z \phi(x, y, z+1) + h_{zz} \phi(x, y, z-1)}{h_z h_{zz} (h_z + h_{zz})} \quad (B-6)$$

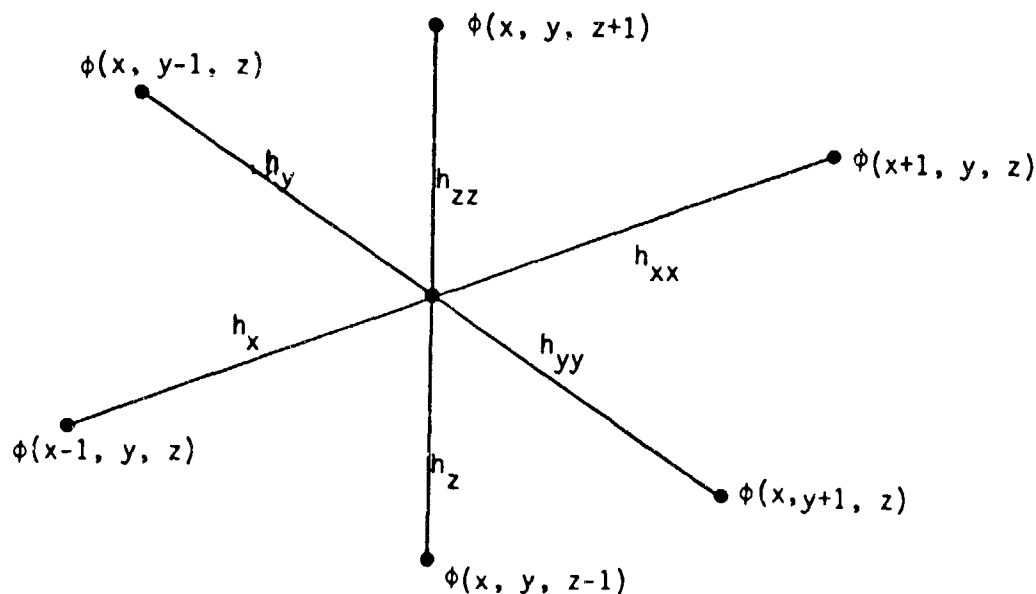

FIGURE B-3. IRREGULAR STAR IN THREE-DIMENSIONAL CARTESIAN CO-ORDINATES

Referring to Figure B-4, the three-dimensional finite difference form in circular cylindrical co-ordinates is:

$$\phi(r, z, \theta) \left(\frac{1}{\Delta_{rr} \Delta_r} + \frac{1}{\Delta_{zz} \Delta_z} + \frac{1}{\Delta_{\theta\theta} \Delta_\theta R_o^2} \right) = \quad (B-7)$$

$$\frac{\phi(r+1, z, \theta) \left(\frac{1}{\Delta_r} + \frac{1}{2R_o} \right) + \phi(r-1, z, \theta) \left(\frac{1}{\Delta_r} - \frac{1}{2R_o} \right)}{\Delta_{rr} + \Delta_r} +$$

$$\frac{\phi(r, z+1, \theta) \left(\frac{1}{\Delta_z} \right) + \phi(r, z-1, \theta) \left(\frac{1}{\Delta_z} \right)}{\Delta_{zz} + \Delta_z} + \frac{\phi(r, z, \theta+1) \left(\frac{1}{\Delta_\theta} \right) + \phi(r, z, \theta-1) \left(\frac{1}{\Delta_\theta} \right)}{R_o^2 (\Delta_{\theta\theta} + \Delta_\theta)}$$

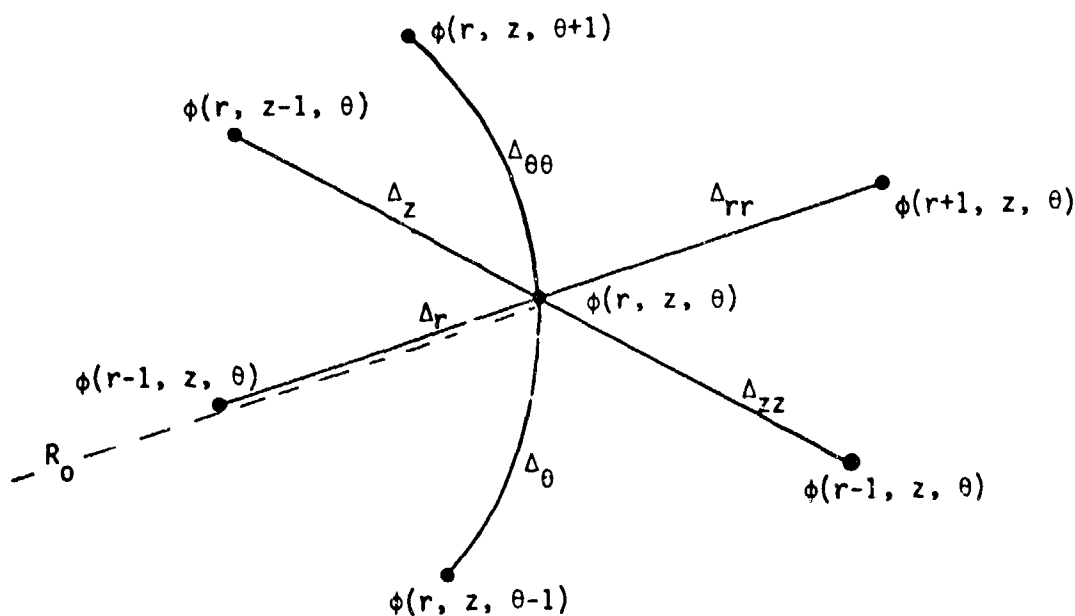

FIGURE B-4. IRREGULAR STAR IN CIRCULAR CYLINDRICAL CO-ORDINATES

Finite difference equations in Cartesian co-ordinates for multiple dielectric systems were developed for two and for three dimensions with one axis of symmetry by Galloway, Ryan, Eng, and Scott,¹²⁰ Storey and Billings,¹²⁷ and Misaki, Yamamoto, and Itaka,¹²⁵ also present techniques for determining finite difference solutions in three-dimensional, asymmetric, multiple dielectric systems.

Successive Over-Relaxation Iteration. To solve the matrix of finite difference equations, successive over-relaxation (SOR) iteration is implemented by using a positive acceleration factor with a Gauss-Seidel iteration.¹³⁰ The finite difference equation for three-dimensional Cartesian co-ordinates is presented as:

$$\begin{aligned} \phi(x, y, z)^{n+1} = & \phi(x, y, z)^n + \left(\frac{\alpha}{k}\right) \left[k_x \{h_x \phi(x+1, y, z)^n + h_{xx} \phi(x-1, y, z)^{n+1}\} \right. \\ & + k_y \{h_y \phi(x, y+1, z)^n + h_{yy} \phi(x, y-1, z)^{n+1}\} \\ & \left. + k_z \{h_z \phi(x, y, z+1)^n + h_{zz} \phi(x, y, z-1)^{n+1}\} - k \phi(x, y, z)^n \right] \end{aligned} \quad (B-8)$$

where $k = \frac{1}{h_x h_{xx}} + \frac{1}{h_y h_{yy}} + \frac{1}{h_z h_{zz}}$ and $k_i = \frac{1}{h_i h_{ii} (h_i + h_{ii})}$ where $i = x, y, z$

It is important that the optimum value (between 1 and 2) for the acceleration factor (α) be used.^{126, 128} The optimum value for α is different for every problem. For problems with many nodes, the following simplified expressions may be used. For a rectangular grid with $1 \times m$ nodes

$$\alpha \text{ optimum} = 2 \left[1 - \pi \left(\frac{1}{(1-1)^2} + \frac{1}{(n-1)^2} \right)^{\frac{1}{2}} \right] \quad (B-9)$$

For a square grid with 1 node per side $\alpha \text{ optimum} = \frac{2}{1 + \sin(\pi/1 - 1)}$.

During the first few iterations, α is taken to be unity.¹³¹

Potential Gradient. Two methods for potential gradient computation are (1) a quadratic method which is recommended for general use on all grid nodes and (2) a more precise differences method for use at specific regions of interest.¹²³

The quadratic method is performed by fitting quadratic equations to the potential values at adjacent points; i.e.,

$$\begin{aligned} \phi_1 &= ax_1^2 + bx_1 + c \\ \phi_2 &= ax_2^2 + bx_2 + c \\ \phi_3 &= ax_3^2 + bx_3 + c \end{aligned} \quad (B-10)$$

The three equations (11) are solved to give values of a and b which are then substituted into the equation for the x-direction gradient

$$E_x = - \frac{\delta\phi}{\delta x} = -(2ax + b) \quad (B-11)$$

Equations of (11) and (12) are determined for each direction and the results yield magnitude and angle of the potential gradient.

The difference method utilizes the forward-difference operator Δ , the central-difference operator δ , and the backward-difference operator.^{123, 126, 128} It incorporates potentials of other nodes in each direction and like the quadratic method computes the potential gradient in each direction. However, the difference method uses many more node potentials, rather than the three for the quadratic method.

The gradient error using the quadratic method is typically less than 2% and using the difference method is typically less than 0.2%.¹²³

Computer Program. The computer program flow chart is given in Figure B-5. It has a time over-run function to print out all the data if there is not enough remaining time for another iteration cycle before convergence. It compares the time taken for the last iteration cycle with the time remaining.

Summary. The numerical method presented gives a practical solution to potential field problems which cannot be represented by standard electrodes and dielectrics. Field distribution can be determined in two dimensions and three dimensions. Important parameters can be obtained such as potential field lines, and potential gradients in magnitude and phase. Errors in the potentials are typically less than 0.5%.

LIST OF SYMBOLS

ϕ	= potential
ϵ	= permittivity
E	= potential gradient
R_0	= distance of any node from axis of symmetry
h_i, h_{ij}	= mesh length for Cartesian co-ordinate system
Δ_i, Δ_{ij}	= mesh length for circular cylindrical co-ordinate system
r, z, θ	= circular cylindrical co-ordinates

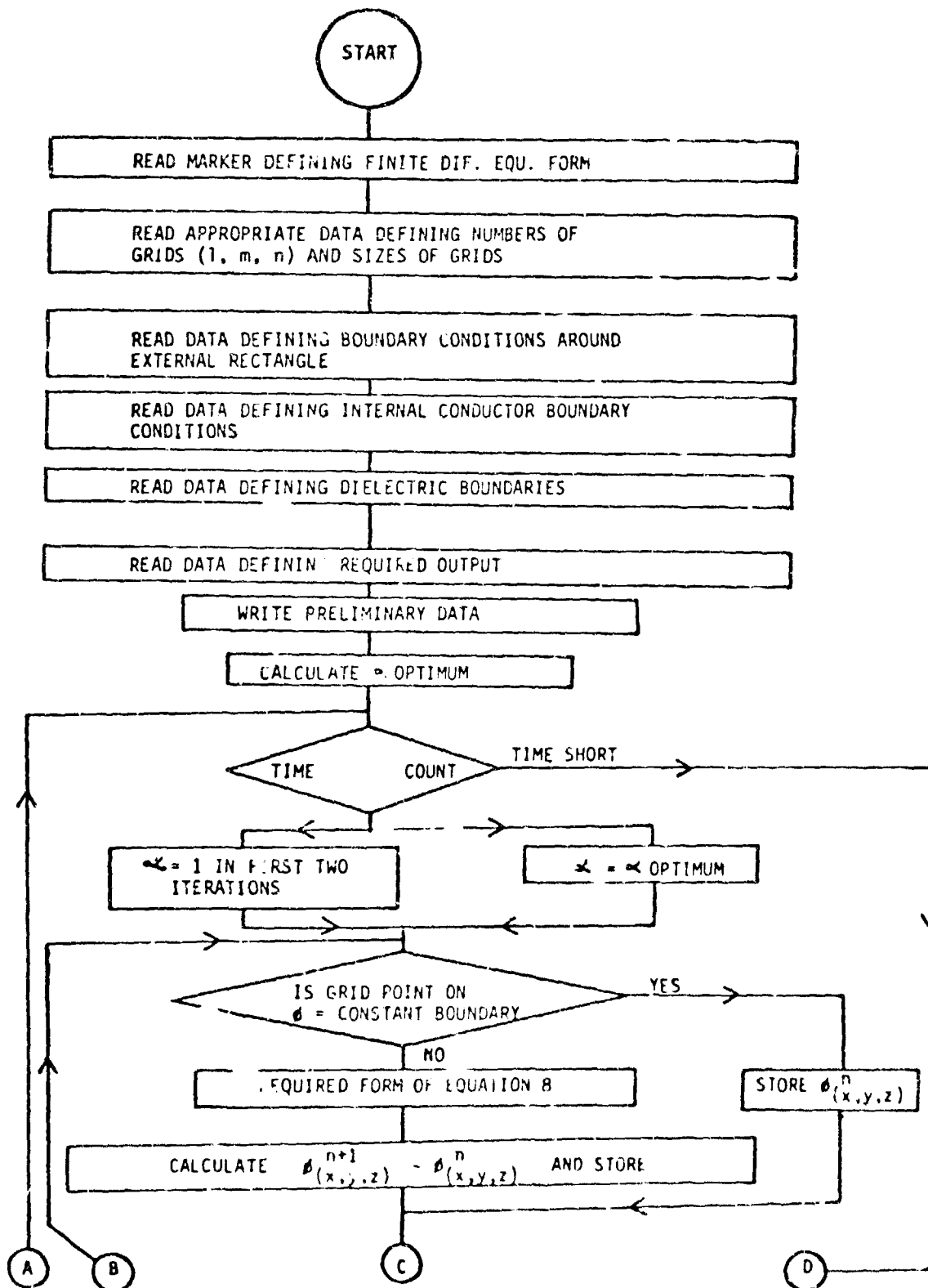

FIGURE B-5. COMPUTER PROGRAM FLOW CHART

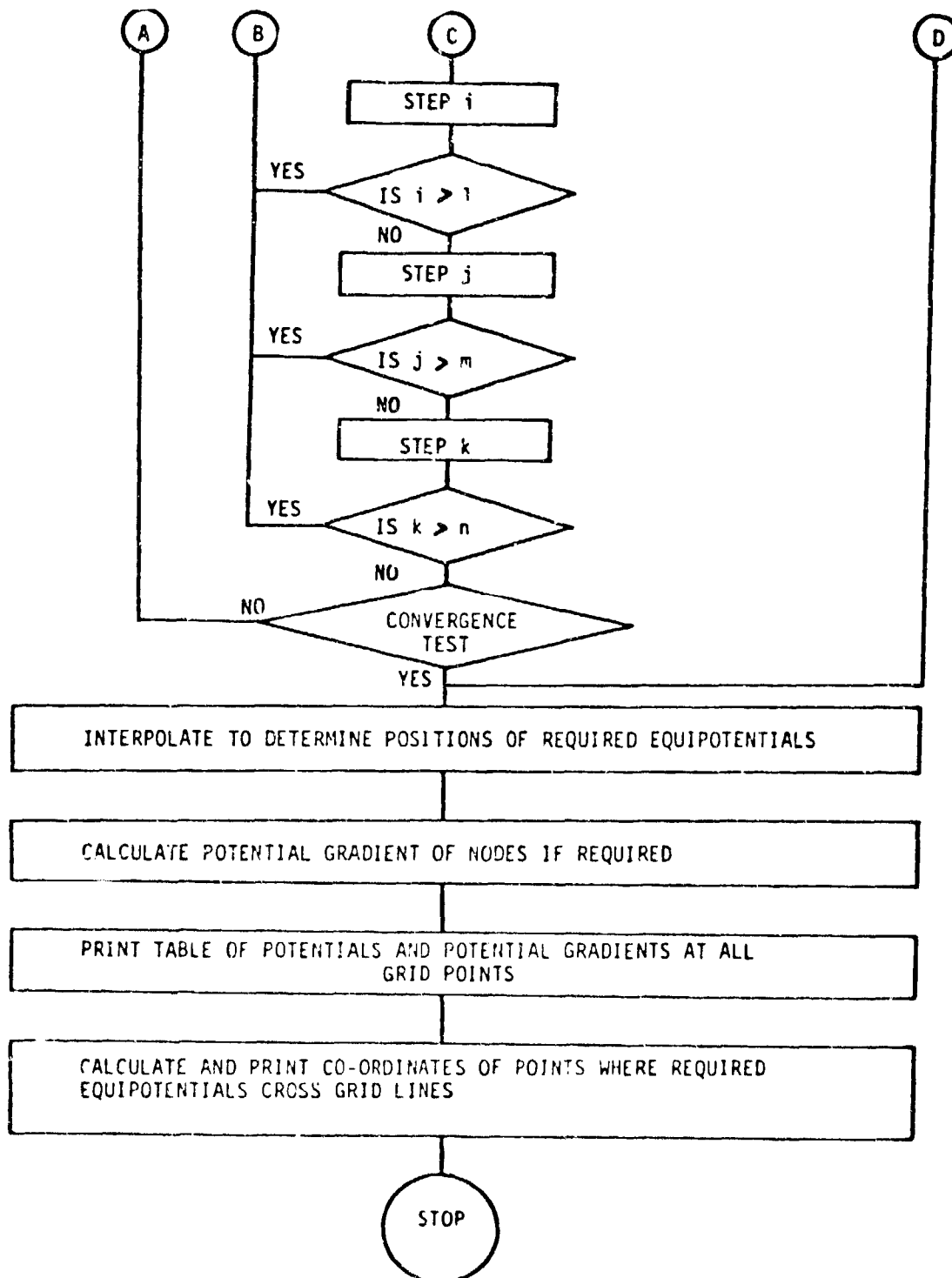

FIGURE B-5. COMPUTER PROGRAM FLOW CHART (Continued)

- x, y, z = Cartesian co-ordinates
 α = acceleration factor
 a, b, c, A, C = constants
 l, m, n = constants governing size of region of solution
 i, j, k = constants
 Δ, δ, ∇ = forward-difference operator, central-difference operator,
 and backward-difference operator

REFERENCES

120. R. H. Galloway, H. M. Ryan, C. Eng and M. F. Scott, "Calculation of Electric Fields by Digital Computer," PROC. IEEE, Vol. 114, No. 6, June 1967, p. 824-829
121. J. M. Mattingley, H. M. Ryan and E. Eng, "Potential and Potential-Gradient Distributions for Standard and Practical Electrode Systems," PROC. IEEE, Vol. 118, No. 5, May 1971, p. 720-732
122. H. M. Ryan, J. M. Mattingley and M. F. Scott, "Computation of Electric Field Distributions in High-Voltage Equipment," IEEE Transactions of Electrical Insulation, Vol. EI-6, No. 4, December 1971, p. 148-154
123. M. F. Scott, J. M. Mattingley and H. M. Ryan, "Computation of Electric Fields: Recent Developments and Practical Applications," IEEE Transactions on Electrical Insulation, Vol. EI-9, No. 1, March 1974, p. 18-25
124. H. Singer, H. Steinbigler and P. Weiss, "A Charge Simulation Method for the Calculation of High Voltage Fields," IEEE Transactions on Power Apparatus and Systems, Vol. PAS-93, No. 5, Sept/Oct. 1974, P.1660-1668
125. T. Misaka, H. Yamamoto and K. Itaka, "An Analysis of Three-Dimensional Asymmetric Field Distribution in SF₆ Gas Insulated Cables," IEEE Transactions on Power Apparatus and Systems, Vol. PAS-92, No. 6, Nov/Dec 1973, P. 2024-2031.
126. K. J. Binns and P. J. Lawrenson, Analysis and Computation of Electric and Magnetic Field Problems, Copyright 1973, Pergamon Press Ltd., Headington Hill Hall, Oxford
127. J. T. Storey, and M. J. Billings, "Determination of the 3-Dimensional Electrostatic Field in a Curved Bushing," PROC. IEE, Vol. 116, No. 4, April 1969, p. 639-643
128. J. T. Storey, and M. J. Billings, "General Digital-Computer Program for the Determination of 3-Dimensional Electrostatic Axially Symmetric Fields," PROC. IEE, Vol. 114, No. 10, p. 1551-1555, 1967.
129. O. W. Anderson, "Laplacian Electrostatic Field Calculations by Finite Elements with Automatic Grid Generation," IEEE Transactions on Power Apparatus and Systems, Vol. PAS-92, No. 5, Sept/Oct 1973, p. 1485-1492

130. R. W. Southworth and S. L. Deleeuw, Digital Computation and Numerical Methods, Copyright 1965, McGraw-Hill, Inc., Library of Congress Catalog Card Number 65-20115
131. "The Determination of the Optimum Accelerating Factor for Successive Over-Relaxation," Computer Journal, 1961, Vol. 4, p. 73.

APPENDIX C

STANDARD METHOD OF TEST FOR MEASUREMENT OF ENERGY AND INTEGRATED CHARGE OF PULSE AND PULSELESS PARTIAL DISCHARGES (CORONA) USING CHARGE-VOLTAGE TRACE TECHNIQUES

Scope. This method is intended to supplement measurement of individual pulses of partial discharges as covered in ASTM D-1868, by measuring the sum of these discharges per cycle in terms of energy. In addition, the technique provides information concerning the increase in specimen capacitance resulting from cavity discharges, and an indirect means of determining the dielectric loss angle, $\tan \delta$, as covered in ASTM D-150.

Significance. Pulse measurements of partial discharges indicate only the magnitude of individual discharges. However, if there are numerous discharges per cycle, it may be important to know their sum, since this sum can be related to the total volume of internal gas spaces which are discharging. Also, in some cases of internal (cavity type) discharges, they may be of a glow, pulseless or psuedo-glow nature, which are not indicated by conventional pulse-discharge detectors.

This method is useful for dc, ac, and dc impressed-on ac voltages. The frequency range for ac voltages is 0 to 400 Hz. Higher-frequency square wave voltages require a change in the detection circuitry to accommodate the square wave rise and fall times and high-frequency harmonics.

Principle of the Method. The method requires the placing of the test specimen, considered essentially as a high-voltage capacitor, in series with a low-voltage capacitor, across a sinusoidal test-voltage source. Two other bridge arms provide a voltage for balancing at an applied voltage level below inception of partial discharges, the sinusoidal voltage across the low-voltage capacitor. Any partial discharges which occur at higher applied voltages in the specimen will be integrated by the low-voltage capacitor to produce an unbalanceable voltage. The unbalanced voltage controls the vertical deflection of an oscilloscope beam, while a voltage proportional to and in phase with the test voltage controls the horizontal deflection. A description of a suitable circuit for this method is detailed in Appendix D.

The oscilloscope display is simply a horizontal line below the discharge inception voltage where no unbalanceable voltages are produced. Above the discharge inception voltage the display opens into an approximate parallelogram. The height of the parallelogram represents the sum of the partial discharges per half cycle, and the area represents the energy dissipated per cycle by the discharges (Figure C-1).

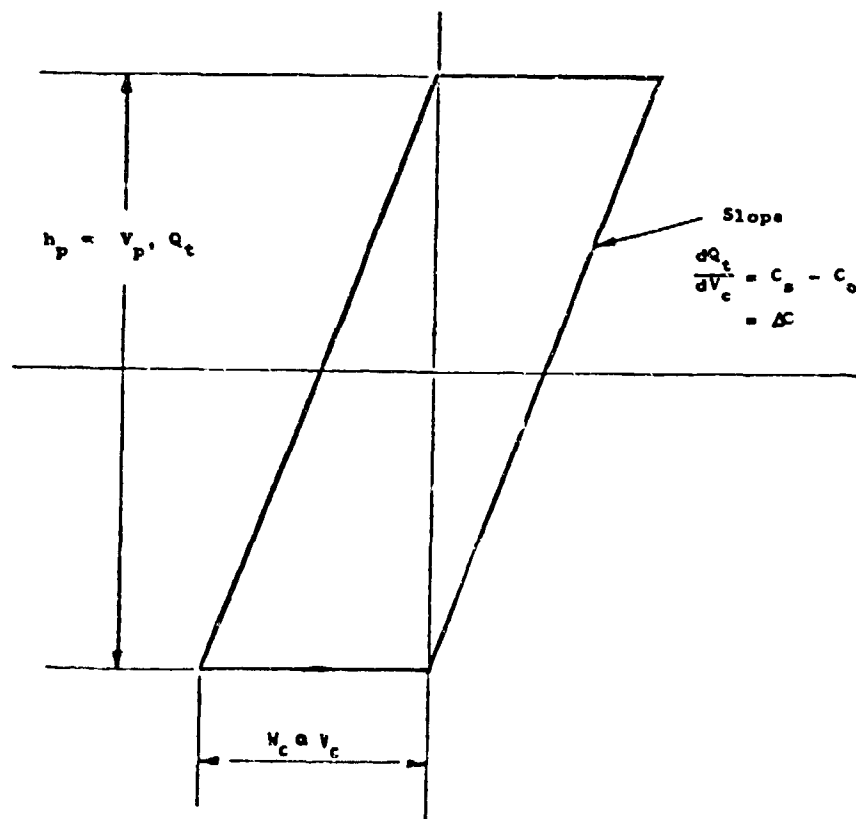

FIGURE C1. IDEALIZED Q - V LOOP TRACE

Precautions - Harmonics. The test voltage must be reasonably free from harmonics in order to produce the required horizontal line below the inception voltage. Harmonics will produce a wavy rather than a flat line. If the waviness is too severe, the voltage source may have to be filtered to remove the harmonics. The removal of harmonics is more important when the quantities to be measured are small.

Surface Discharges. All discharges in the test specimen are measured, whether on the surface or in internal cavities. If it is desired to measure only internal cavities, the other discharges must be avoided. In the case of an insulated conductor with an outer electrode on the surface (such as a cable or generator coil), the surface discharges at the end of this outer electrode can be removed from the measurement with a closely-spaced guard ring connected to ground or by insulating-fluid immersion.

Calibration of Oscilloscope Coefficients. In order to evaluate the parallelogram (Figure C-1), it is necessary to determine the deflection sensitivities of the oscilloscope. The horizontal-deflection sensitivity S_x is found from observing the horizontal deflection D_h to a test voltage having a peak-to-peak value of V_c as measured by accurate independent means.

$$S_x = V_c / D_h \quad (C-1)$$

The vertical-deflection sensitivity, S_y , may be found from observing the vertical deflection, D_v , to a known charge, Q_c , injected into the low-voltage capacitor. The charge may be produced by a square-wave generator having a peak-to-peak voltage, E_c , coupled to the low-voltage capacitor through a calibrating capacitor, C_c , of a much smaller value.

$$S_y = \frac{Q_c}{D_v} = \frac{E_c C_c}{D_v} \quad (C-2)$$

Alternatively Q_t may be determined from the turns ratio, n , of the detector transformer, T , and the voltage, V_p , required at the vertical input of the oscilloscope to produce a vertical deflection of the same magnitude as that produced by the discharges. V_p may be directly measured by connecting a peak-to-peak reading voltmeter directly across the vertical input of the oscilloscope as shown in figure C-1, and read when the parallelogram is obtained. Then:

$$Q_t = n V_p C_4 \quad (C-3)$$

Where Q_t is the total charge per half cycle.

Calculation of Results. Integrated Charge. The integrated charge per half cycle, Q_t , is the product of the vertical deflection, D_y , of the oscilloscope (of the height of the parallelogram) multiplied by the vertical-deflection

sensitivity S_y .

$$Q_t = D_y S_y \quad (C-4)$$

Energy. The energy per cycle is the area of the parallelogram measured in the same units as the deflection sensitivities.

$$W = A S_x S_y \quad (C-5)$$

Where the parallelogram is well defined the area is the product of the parallelogram height, D_y , and width, D_x , conveniently measured along the center axes of the oscilloscope raster.

$$\text{Thus:} \quad W = D_x D_y S_x S_y \quad (C-6)$$

Volume of Internal Gas Space. If Q_t is graphed vs crest voltage applied, V_c , for a sufficient range of voltages above the discharge-inception voltage, one will usually obtain a straight line, if one has avoided the effect of surface discharges from a surface electrode edge with a guard electrode or oil immersion. The slope of this line $dQ_t/dV_c = C_s - C_o$ is equal to the difference between the capacitance of the specimen with the discharging cavities shorted out, C_s , and the capacitance, C_o , of the sample measured below the discharge-inception voltage. It is the same slope as the straight portion side of the parallelogram figure, after conversion to proper units. If the internal gas space is considered as a simple gas capacitance in series with the solid insulation, then the following calculation gives the fraction of cavities in the insulation:

$$\frac{\text{volume of internal gas space}}{\text{volume of solid insulation}} = \frac{C_s - C_o}{k_s C_o} \quad (C-7)$$

where k_s is the dielectric constant of the solid or solid-liquid insulating system.

Interpretational Analysis. The peak-to-peak-voltage height, h_p , of the parallelogram in Figure C-1, whether measured on the oscilloscope or with a peak-indicating meter, is used to calculate the total charge transferred by all the discharges occurring in a half cycle ($Q_t - nV_p C_4$) as the voltage swings from positive to negative crest and vice versa. The width of the parallelogram, w_c , is proportional to the peak or crest value of the applied voltage, V_c , which for

the idealized straightedged parallelogram in Figure C-1 is equal to the partial-discharge inception-voltage value. Figure C-1 applies therefore in cases where the discharge onset in all cavities occurs at the same value of applied voltage. In such circumstances,

$$V_p = Kh_p = Q_t/nC_4 \quad (C-8)$$

and $V_c = K_o W_c \quad (C-9)$

where K and K_o are calibration constants. With Q_t and V_c determined from the parallelogram, the energy-loss per cycle, W, due to all discharges is given by

$$W = Q_t V_c \quad \text{joules} \quad (C-10)$$

and the power loss, P, is therefore

$$P = \frac{\omega}{2\pi} W = \frac{\omega Q_t V_c}{2\pi} \quad \text{watts} \quad (C-11)$$

where ω is the radian frequency.

In practical insulating systems voids generally discharge at unequal voltages, with the result that at first discharge initiation not all the cavities necessarily discharge. Moreover, with increasing applied voltage increasingly more cavities begin to discharge and this effect further accentuates the smooth corner curvatures of the parallelogram in contrast to the sharp edges of the idealized trace shown in Figure C-1. As a result, equations C-10 and C-11 can no longer be used when a certain degree of accuracy is required and the discharge-energy-loss per cycle must now be determined using a planimeter. The area, A, determined by the planimeter constitutes a direct measure of the corona energy and power loss:

$$\begin{aligned} \text{i.e., } A &= \int h_p d(W_c) = \int Q_t/nC_4 K_o \cdot d\left(\frac{V_c}{K_o}\right) \\ &= \frac{1}{nC_4 k k_o} \int Q_t d(V_c) \end{aligned} \quad (C-12)$$

$$W = A (nC_4 k k_o) \quad \text{joules} \quad (C-13)$$

and $P = \frac{\omega}{2\pi} A (nC_4 k k_o) \quad \text{watts} \quad (C-14)$

Sometimes it is desirable to determine the effect of discharges on the dissipation-factor value, $\tan \delta$, particularly since the latter is normally employed in the measurement of "ionization factor" of cables. The discharge-power loss, P , may be expressed in terms of the $\tan \delta$ value, as,

$$P = \omega C_x \tan \delta \left(\frac{V_c}{2} \right)^2 \quad (C-15)$$

$$\text{or } \tan \delta = \frac{2P}{\omega C_x V_c^2} \quad (C-16)$$

Hence for the idealized case in Figure C-1

$$\tan \delta = \frac{Q_t}{C_x V_c} \quad (C-17)$$

However, for an insulating system having cavities with a wide distribution of partial discharge initiation voltages, P must again be determined in terms of equation (C-14).

Report. Identification - Includes information which describes the kind or type of material so as to permit reordering the same material, to permit comparison between different materials or different production lots of the same material and to permit other types of comparison between different materials.

Description -- Includes information as to name, color, grade form, manufacturer, source, size, shape, and fabrication details which are not primarily related to identification.

Method of Test -- Includes a description of the test procedure, test apparatus, test specimen, test conditions (stresses), the amplitude of each stress and the length of time applied, preconditioning and history, and ambient conditions and any other factors which may influence the performance of the test and the result obtained, and which will permit exact duplication of the tests at a later time.

Test Results -- Includes experimental values obtained and number of test specimens along with results from appropriate calculations such as average, mean, statistical deviation, etc.

Observations -- Includes information of importance to the understanding or interpretation of the test method and results which have not been included in the foregoing sections.

APPENDIX D

CIRCUIT FOR STANDARD METHOD OF TEST FOR MEASUREMENT OF ENERGY AND INTEGRATED CHARGE OF PULSE AND PULSELESS PARTIAL DISCHARGES USING CHARGE-VOLTAGE TRACE

A suitable circuit for the loop-trace (parallelogram) method is shown in Figure D-1. A detailed list of the circuit components and the measurement procedure follows:

Apparatus. Bridge. The bridge shown in Figure D-1 consists of four essentially capacitive arms. There are two high-voltage arms, as in a high-voltage Schering type bridge. One of these, C_x , (or C_2) is the specimen to be measured. The second, (C_1), is a high-voltage discharge-free capacitor, usually a 100 pF standard capacitor, with $\tan \delta < .0001$. The two low-voltage arms, C_3 and C_4 , are capacitance arms, balancing the bridge at a voltage just below the discharge-inception voltage, and then raising the voltage above the discharge-inception voltage. The unbalance voltage above the discharge-inception voltage is proportional to the sum of the discharges in the specimen per half cycle, providing certain precautions are taken. The unbalance voltage of the bridge is displayed on the vertical axis of an oscilloscope, and the horizontal axis is driven by a voltage proportional to and in phase with the high voltage applied to the bridge. The oscilloscope display properly consists of a horizontal line at balance below the discharge-inception voltage. Above the discharge-inception voltage, the display breaks into an approximate parallelogram, with small steps on each sloping side, but with a flat, smooth trace on the top and bottom. The sloping sides of the parallelogram are the discharging portion of the voltage cycle, and the top and bottom are the nondischarging portions of the cycle.

Normal losses in the specimen are balanced by a variable resistor R_1 in series with C_1 . A convenient range for R_1 is from 0-1 megohm. Further balance is provided by variable resistor R_4 in parallel with C_4 . Resistor R_4 also functions to control the average voltage level across C_4 which might rise to unacceptable values if the discharges of one polarity recurrently exceed those of the other polarity. Resistor R_4 should have a sufficiently high value to avoid any significant drain on the charge accumulated on C_4 during one half cycle of the test voltage. Thus $R_4 C_4 > 1/2 f$ where f is the frequency of the test voltage.

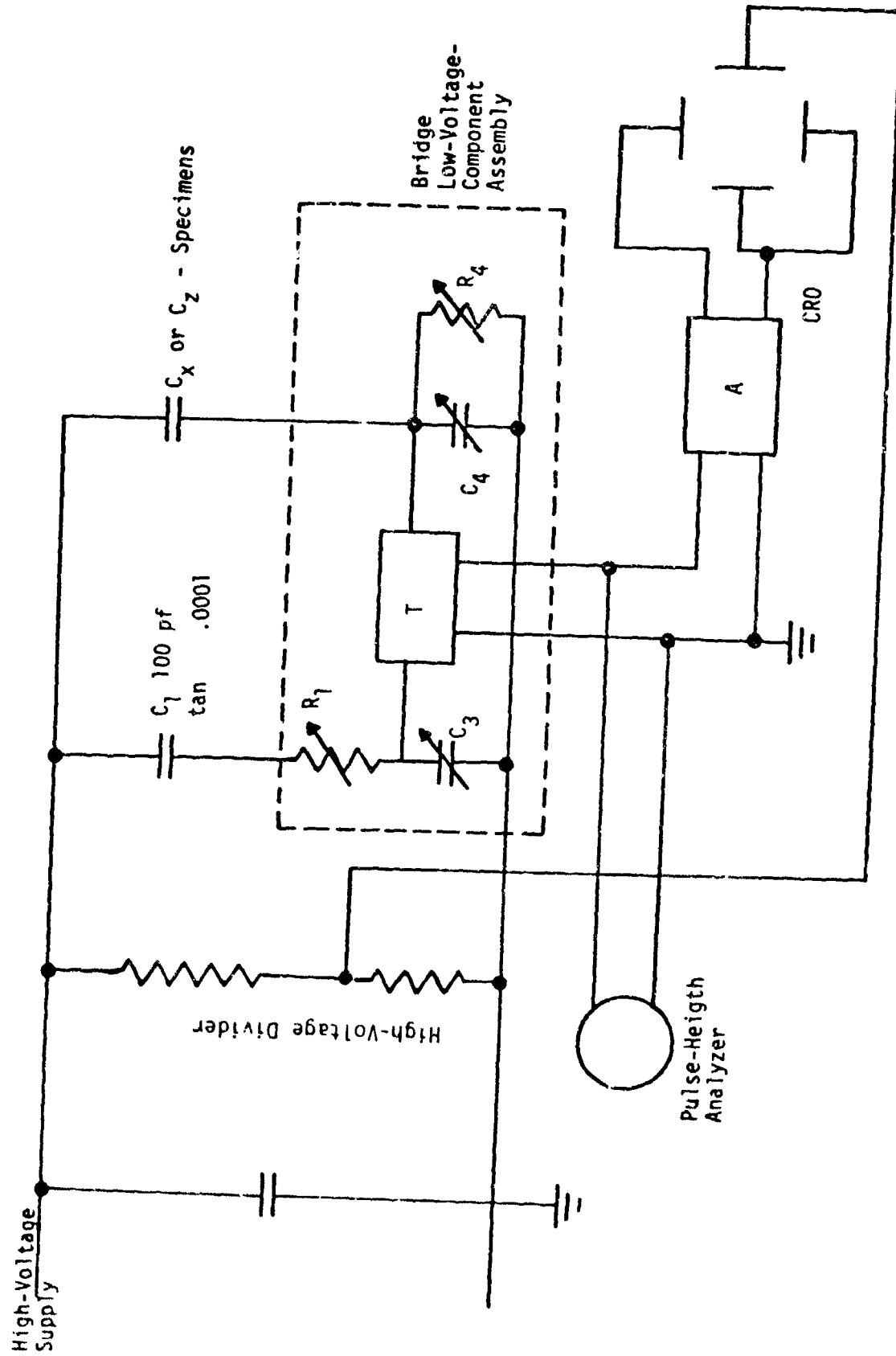

FIGURE D-1, CIRCUIT DIAGRAM OF A TYPICAL CHARGE-VOLTAGE-TRACE BRIDGE

The loss tangents of variable capacitors C_3 and C_4 should preferably be less than 0.0001. If greater than 0.0001, and unequal in value, their loss tangents will have to be compensated for by adjustment of R_4 and R_1 . In this latter case, it would not be possible to calculate the loss tangent of C_x from the values of R_1 and C_2 or R_4 and C_4 .

Transformer T should have a ratio near unity (3/1 has been used), with the primary having the most turns. The primary should have a 60-Hz impedance greater than 0.2 Ω .

High Voltage Supply. A high voltage transformer with a variable supply voltage having a minimum amount of harmonics and ripple is required. Special filtering to remove harmonics or ripple may be required if they are great, and high sensitivity is desired. It is also necessary to place a capacitor between the high voltage supply terminal and ground, in parallel with the bridge terminals. This should be as large as possible to minimize voltage drop at the bridge terminals due to discharges.

Measurement Procedure. The specimen, C_x , is connected in the bridge, as indicated in Figure D-1. The applied voltage is raised to 500 to 1000 volts (rms), which is usually below the discharge-inception voltage. With thick specimens, higher voltages may be used. With very thin specimens, it may be necessary to stay below 300 volts to obtain an initial balance. In balancing the bridge, element C_4 is usually set first so as to achieve maximum sensitivity without exceeding 100 volts on the element $C_4 > (V_t/100) C_x$. This requires a knowledge of the approximate capacitance of the specimens. If this is not known, a safe high value of C_4 may be chosen for a preliminary balance. The value of C_x is then calculated from this: $C_x = (C_1 C_4 / C_3)$, and C_4 is then reset for a second balance. Balance of capacitance is achieved by adjusting C_3 after C_4 is set. Balance of the $\tan \delta$ of the specimen is made by adjusting R_4 or R_1 .

After initial low voltage balance is achieved, the voltage is raised to selected levels above the discharge-onset voltage, which is evident from a sudden change in the oscilloscope trace from a nearly horizontal line to an open (approximate) parallelogram with step sides. Whether or not the steps are apparent depends on the detector sensitivity and the ratio of individual pulse discharge size to the sum of these per cycle.

Then the voltage is raised above the discharge onset voltage, the parallelogram figure may sometimes tilt so as to have sloping top and bottom sides or develop a curved top. This is due to changing $\tan \delta$ or capacitance of the solid (or liquid) insulation of the specimen with voltage, not due to discharges. If this happens, a small adjustment in C_3 , R_1 or R_4 may correct the orientation and curvature so that the top and bottom are horizontal and flatter.