

ey 4

NOV

1978

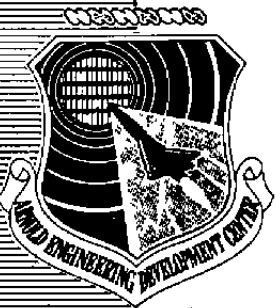

**THE DEVELOPMENT OF
HOT-WIRE ANEMOMETER TEST CAPABILITIES
FOR $M_\infty = 6$ AND $M_\infty = 8$ APPLICATIONS**

**VON KÁRMÁN GAS DYNAMICS FACILITY
ARNOLD ENGINEERING DEVELOPMENT CENTER
AIR FORCE SYSTEMS COMMAND
ARNOLD AIR FORCE STATION, TENNESSEE 37389**

September 1976

Final Report for Period September 25 – October 7, 1975

Approved for public release; distribution unlimited.

Proprietary

Prepared for

**SPACE AND MISSILE SYSTEMS ORGANIZATION (RSSE)
PO BOX 92960, WORLDWAY POSTAL CENTER
LOS ANGELES, CALIFORNIA 90009**

NOTICES

When U. S. Government drawings specifications, or other data are used for any purpose other than a definitely related Government procurement operation, the Government thereby incurs no responsibility nor any obligation whatsoever, and the fact that the Government may have formulated, furnished, or in any way supplied the said drawings, specifications, or other data, is not to be regarded by implication or otherwise, or in any manner licensing the holder or any other person or corporation, or conveying any rights or permission to manufacture, use, or sell any patented invention that may in any way be related thereto.

Qualified users may obtain copies of this report from the Defense Documentation Center.

References to named commercial products in this report are not to be considered in any sense as an endorsement of the product by the United States Air Force or the Government.

This report has been reviewed by the Information Office (OI) and is releasable to the National Technical Information Service (NTIS). At NTIS, it will be available to the general public, including foreign nations.

APPROVAL STATEMENT

This technical report has been reviewed and is approved for publication.

FOR THE COMMANDER

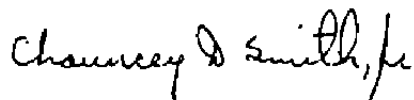

CHAUNCEY D. SMITH, JR.
Lt Colonel, USAF
Chief Air Force Test Director, VKF
Directorate of Test



ALAN L. DEVEREAUX
Colonel, USAF
Director of Test

UNCLASSIFIED

20. ABSTRACT (Continued)

subsequent detailed analysis is performed using the tape record. Auxiliary systems have been fabricated which permit model boundary-layer surveys to be made in steps as small as 0.001 in. Optical techniques have been developed that make it possible to monitor and measure probe position relative to the model surface in 0.001-in. increments. Representative results obtained in two series of boundary-layer studies using these capabilities at free-stream Mach numbers of 6 and 8 are shown.

PREFACE

The work reported herein was conducted by the Arnold Engineering Development Center (AEDC), Air Force Systems Command (AFSC), at the request of the Space and Missile Systems Organization (SAMSO/RSSE) for Aeronutronic Ford Corporation under Program Element 63311F, Project 627A, Task 01. The results were obtained by ARO, Inc. (a subsidiary of Sverdrup & Parcel and Associates, Inc.), contract operator of AEDC, AFSC, Arnold Air Force Station, Tennessee, under ARO Project Number V41B-84A. The authors of this report were J. C. Donaldson, C. G. Nelson, and J. E. O'Hare, ARO, Inc. Data reduction was completed on December 19, 1975, and the manuscript (ARO Control No. ARO-VKF-TR-76-38) was submitted for publication on March 30, 1976.

The suggestions and assistance of Dr. A. Demetriades, Dr. A. J. Laderman, and Mr. L. Von Seggern of Aeronutronic Ford Corporation in the development of capabilities discussed herein are gratefully acknowledged.

CONTENTS

	<u>Page</u>
1.0 INTRODUCTION	5
2.0 GENERAL CONSIDERATIONS	6
3.0 TUNNEL DESCRIPTION	6
4.0 MECHANISM FOR BOUNDARY-LAYER SURVEYS	7
5.0 INSTRUMENTATION	8
6.0 HOT-WIRE ANEMOMETER PROBES	11
7.0 OPTICAL-MECHANICAL TECHNIQUE FOR POSITIONING PROBES	11
8.0 DATA ACQUISITION AND REDUCTION	13
9.0 CONCLUSIONS	15
REFERENCES	15

ILLUSTRATIONS

Figure

1. Tunnel B	
a. Tunnel Assembly	17
b. Tunnel Test Section	17
2. Probe Drive Mechanism	18
3. Typical Survey Probe Assemblies	
a. Multi-Probe Rake, Remotely Actuated Shield	19
b. Hot-Wire Anemometer Probe, Mechanically Actuated Shield	20
4. Assembled Instrumentation	21
5. Hot-Wire Measurements Instrumentation in the Data Record Mode	22
6. Silhouette Photograph of a Typical Fine-Wire Mounting	23
7. Television Cameras and Mount	24
8. High-Resolution Television Images	
a. Pitot Pressure Probe near Surface	25
b. Model Surface Profile with Roughness	26
9. Video and Light Source System	27
10. Typical Qualitative Hot-Wire Anemometer Response Signal from a Survey through the Boundary Layer on a Blunt Body	28
11. Typical Qualitative Hot-Wire Anemometer Signal Map from Surveys of the Boundary Layer on a Sharp Cone	29
12. Typical Variations of Velocity and Temperature Fluctuations across the Boundary Layer of a Sharp Cone at Zero Angle of Attack	30
NOMENCLATURE	31

1.0 INTRODUCTION

Recent considerations of the design and performance of hypersonic flight vehicles have emphasized the importance of studies of transition to turbulence in the associated boundary layers. Limitations in the analytical models of the flow have generally dictated reliance upon empirical foundations in formulating prediction methods. Important to a characterization of boundary-layer transition is information from the interior of the layer regarding the progression of small disturbances (flow fluctuations) as a phenomenon related to the transition process.

Hot-wire anemometry techniques are generally recognized as a principal method for the measurement of flow fluctuation parameters. Measurements in the wind tunnels of the von Kármán Gas Dynamics Facility have been discussed by Donaldson and Wallace (Ref. 1). These studies were conducted in intermittent-flow tunnels. The efficient application of the techniques in a "production-type" of operation was required, however, to make the method economically attractive for use in continuous-flow wind tunnels. Such applications have been made in cooperation with Aeronutronic Ford Corporation of Newport Beach, California.

A series of experimental studies has been conducted in the 50-in. (1.27 m) Hypersonic Tunnel (B) of the von Kármán Gas Dynamics Facility to examine the relative roles of natural instability, mass addition, and surface roughness in promoting boundary-layer transition on a blunt body (Refs. 2 and 3). Another series of experiments was made to examine effects of mass transfer on turbulent viscous flow properties of a slender cone at angles of attack (Refs. 4 and 5). In both investigations, the hot-wire anemometer was the principal instrument for measuring flow fluctuation parameters.

This report discusses the anemometer instrumentation and optical and mechanical equipment which have been assembled within the von Kármán Gas Dynamics Facility for making flow-fluctuation measurements in the wind tunnel applications cited. The basic electronic equipment and certain auxiliary components are listed, and the specialized optical and mechanical devices which have facilitated the use of hot-wire anemometers in boundary-layer surveys are described. The capabilities for survey probe construction which have been developed and the data handling techniques which have been used for the specific testing applications are outlined.

The hot-wire anemometry instrumentation and techniques described can be used in other wind tunnels of the von Kármán Facility; however, alternate methods for positioning the probes and for mounting the high-resolution television system would be required.

2.0 GENERAL CONSIDERATIONS

The application of a hot-wire anemometer to the task of measuring fluctuating components of various flow parameters is essentially the immersion of a very small heated wire into the flow and the observation of the heat-transfer phenomena which result, using known or calibrated behavior characteristics of the wire material and of cylinders oriented at a given attitude with respect to the mean flow direction.

Quantitative results can be deduced from simultaneous comparisons of several response histories of the sensor operated at different sensitivities while maintaining position and orientation with respect to the mean flow direction. Time limitations often dictate that boundary-layer explorations be made in a cursory manner. As an example, a boundary layer may be surveyed in a single continuous traverse using only one wire-heating current (wire sensitivity). The resulting response history of the wire is, nevertheless, of sufficient content to define heights within the layer where significant changes of the nature of the flow, that is, changes of the local resultant rate of heat transfer, occurred. Specifically, these qualitative data are useful in exploratory investigations concerned with movement or alteration of transition regions, in contrast to a concern for the magnitude of the parameter fluctuations.

The fidelity with which the response signals are handled by the electronic components is a crucial consideration in view of the nature of some of the heat-transfer perturbations to be detected by the sensor. As an example, the frequencies of the flow fluctuations encountered by the sensor in a hypersonic boundary layer may be on the order of 100 kHz, and the perturbations introduced by mass addition through a porous surface may contribute significant components which have an associated frequency on the order of 1 MHz. The necessity of handling signals of this nature also places restrictions upon the size of the sensor because the finite heat capacity of the sensing element results in a time lag in the sensor response which must be compensated for in the electronic circuitry.

These considerations have served as a partial guide in the choice and design of the major electrical and mechanical components which have been assembled for specific hot-wire anemometry applications and which are discussed in detail in subsequent sections of this report.

3.0 TUNNEL DESCRIPTION

The Hypersonic Tunnel B of the von Kármán Gas Dynamics Facility (Fig. 1) is a continuous, closed-circuit, variable-density wind tunnel with an axisymmetric contoured nozzle and a 50-in. (1.27-m) diameter test section. The tunnel can be operated at a nominal

Mach number of 6 or 8, using interchangeable nozzle sections, at stagnation pressures from 20 to 300 psia (140 to 2,100 kpa) and 50 to 900 psia (340 to 6,200 kpa), respectively, at stagnation temperatures up to 1,350°R (750°K). The tunnel test section is equipped with a model injection system whereby a model may be injected into the test section for a test run and, subsequently, retracted for model cooling or model configuration changes without interrupting the tunnel flow. Two fused quartz windows on each side of the test section are used for the shadowgraph (or schlieren) flow visualization system. The viewing area of each window is about 17.25 in. (0.438 m) in diameter. An access port (or an additional window panel) is also available on top of the test section.

An auxiliary gas supply system is available to deliver various gases to the test article. Air, nitrogen, helium, Freon[®]-12, and sulfur hexafluoride have been used at various mass flow rates. However, air is the only injectant gas which has been used with the hot-wire anemometer. A resistance-type heater is available for preheating injectant air. Equipment for measuring and regulating the mass flow supplied to the test article is part of the system. Sonic orifice plates with various orifice diameters and needle-type control valves are used for most applications. For very low mass flows (down to 2×10^{-6} lbm/sec (0.91×10^{-6} kg/sec)), hot-film anemometer mass flowmeters and micrometering valves are available.

4.0 MECHANISM FOR BOUNDARY-LAYER SURVEYS

A probe-drive mechanism is available which makes it possible to change probes without interrupting the tunnel flow. The mechanism is housed immediately above the port in the top of the tunnel test section (Figs. 1 and 2). Access to the test section is through a 40-in. (1.02-m) long, 4-in. (0.10-m) wide slot which can be sealed by a pneumatically operated door. Separate drive motors are provided to (1) insert the mechanism into the test section or retract it into the housing, (2) position the mechanism at any desired axial station over a range of 35 in. (0.89 m) with a precision of ± 0.001 in. (± 0.025 mm), and (3) survey a flow field of approximately 10 in. (0.25 m) depth with a precision of ± 0.001 in. (± 0.025 mm). The relative position of the survey probe with reference to the model surface is measured and monitored using a high-resolution closed-circuit television system (Section 7.0). The drive axis of the probe support strut for the flow-field surveys can be pitched to any angle between 7 deg forward and 15 deg aft with reference to the vertical in order that the surveys can be made in the direction normal to a model surface; for example, that of the cone in Fig. 3a. An offset extension of the strut is available which permits surveys to be made downstream of the test section access port. A holder for the measurement probe(s) is mounted at the bottom of the strut. The foot of the drive strut can be equipped with a hydraulically operated shield to protect the hot-wire probe during injection and retraction through the tunnel boundary layer, during

changes of tunnel conditions, and at all times when the probe is not being used. The shield is shown in the raised position in Fig. 3a.

An alternate approach has been successful for probing the very thin boundary layer on a blunt body using a rotary-type mechanism mounted on the foot of the drive strut. Boundary-layer traverses in incremental steps of 0.001 in. (0.025 mm) were achieved with a survey probe mounted on a wheel rotated by a worm gear. For the thin boundary layers (on the order of 0.02 in. (0.5 mm)), the arc described by the tip of the probe during the survey approximated the chord in length and orientation relative to the direction normal to the surface. Protection of the hot-wire anemometer when not in use was achieved using a mechanically actuated mini-shield shown in Fig. 3b. The rotary drive and the shielding mechanism were designed and fabricated by Aeronutronic Ford Corporation.

5.0 INSTRUMENTATION

The assembled components of hot-wire anemometer instrumentation and associated electronic equipment are shown in Fig. 4 and schematically in Fig. 5. Descriptions of the capabilities and functions of the components are given in this section.

5.1 HOT-WIRE ANEMOMETER INSTRUMENTATION

The principal instrument of the VKF hot-wire anemometer system is the Aeronutronic Ford Corporation constant-current Model ADP12/13 amplifier/current control. Some of the features of this unit are:

1. Use of wide-band modular operational amplifiers for stable, drift-free operation;
2. Pushbutton selection of up to fifteen, individually adjustable wire heating currents;
3. Buffered analog outputs for d-c wire voltage and wire current;
4. Amplifier low-frequency gain adjustable from 50 to 500;
5. Compatibility with the Shapiro/Edwards Model G50 square-wave generator in wire time-constant adjustments;

6. Wire time-constant compensation adjustable from 5 to 500 μ sec with a 500 to 1 "floor-to-ceiling" ratio;
7. Low-frequency cutoff adjustable from 5 Hz to 20 kHz; and
8. High-frequency cutoff adjustable from 60 kHz to 3 MHz.

5.2 MAGNETIC TAPE RECORDER

Hot-wire response signals are tape recorded using a Bell and Howell VR3700B magnetic tape recorder equipped with wide-band "Group II" electronics. High-frequency cutoff for this machine is 500 kHz for FM recording and 2 MHz for direct recording, at a tape speed of 120 in./sec (3.05 m/sec). The signal-to-noise ratio at 120 in./sec (3.05 m/sec) is 35 db for FM and 22 db for direct. Both 1-in. (2.54-cm) and 0.5-in. (1.27-cm) record/reproduce heads are available. Wide-band record electronics for this machine are currently limited to seven FM channels and four direct channels.

5.3 SPECTRUM ANALYZER

A real-time frequency analysis of the hot-wire response signal is provided by a Hewlett-Packard spectrum analyzer which consists of the following components:

1. Model 141T mainframe with variable persistence CRT display,
2. Model 8552B high-resolution IF section,
3. Model 8553B RF tuning section, and
4. Model 8556A LF tuning section.

These components cover the frequency range from 20 Hz to 110 MHz. The real-time analysis is particularly useful in the identification of undesirable signals such as electrical noise pickup and sensor strain-gage effects.

5.4 AUXILIARY SUPPORT EQUIPMENT

Various instruments available for direct support of hot-wire tests are listed below:

1. Oscilloscopes: Tektronix Model 551 with dual-trace plug-in units and other more recent single-beam models;
2. High-sensitivity and -precision digital voltmeters with auto-ranging: Hewlett-Packard Model 3440A/3443A, Data Precision Model 3500, Fluke Model 8375A;

3. Voltage-to-frequency converters: VIDAR Model 260;
4. Frequency counters: CMC Model 605A, Data Precision Model 5740;
5. True-rms voltmeters with d-c output: Hewlett-Packard Models 3400 and 3403C;
6. X-Y plotters: Hewlett-Packard Models 7045A, 7047A, and 7001A;
7. Bandpass filter: Krohn-Hite Models 3103 and 3202;
8. Square-wave generator for wire time constant adjustment: Shapiro/Edwards Model G-50;
9. Time code generator: Datametrics Model SP425-A/B;
10. Tape search unit: Datametrics Model SP-425 TS; and
11. Wide-band amplifier: Dynamics Electronics Model 7525.

5.5 SUPPORT EQUIPMENT FABRICATED BY THE VKF

Several components have been fabricated by the VKF for support of hot-wire testing:

1. Analog Computer: This computer, which was designed to facilitate wire calibrations, uses analog multifunction modules for computing outputs proportional to the hot-wire resistance and the square of the wire heating current;
2. Data Interval Timer: During data acquisition, for example for each selected wire sensitivity, it is desirable to record a "valid data" identification tone on the magnetic tape record. The timer unit provides an adjustable (up to 10 sec) contact closure in response to a momentary pushbutton command;
3. Hot-Wire Switch. This unit permits selection of either of several hot wires or a calibration resistor at the input to the system;
4. Plotter Sweep Control: When anemometer signals are being recorded on magnetic tape, it is desirable to have a display of the history of the rms level of the recorded a-c wire voltage for real-time validation of the recording. This control unit utilizes digital techniques to generate a time-sweep with an infinite-hold interlocked with the tape machine "record" mode; and

5. Tone Detector: This unit detects the "valid data" tone on the tape record as it is played back and provides a delayed sequencing signal.

6.0 HOT-WIRE ANEMOMETER PROBES

Capabilities have been developed within the von Kármán Facility for the fabrication of hot-wire anemometer probes suitable for hypersonic flows. The probe design is the same as that of probes supplied initially by Aeronutronic Ford Corporation and described by Doughman in Ref. 6. Platinum-rhodium alloy (90 and 10 percent, respectively) wires, drawn by the Wollaston process, of 20- and 50- μ in. (0.51- and 1.27- μ m) nominal diameter and approximately 150 diameters length are attached to sharpened three-mil nickel wire supports using a gold-bonding technique (Ref. 7). The wire supports are inserted through an alumina cylinder of 0.031-in. (0.79-mm) diameter and 0.4-in. (1.0-cm), length which is, in turn, cemented to an alumina cylinder of 0.094-in. (2.39-mm) diameter and 3.0-in. (7.6-cm) length carrying the hot-wire leads through the probe holder. A silhouette photograph (made by the VKF) of a highly magnified typical wire mounting is shown in Fig. 6.

Before hot-wire anemometer measurements were attempted in Tunnel B, a preliminary investigation was conducted to establish that fine hot wires would survive in the environment of the tunnel test section. The probes used in the survivability study had wires of 20- and 50- μ in. (0.51- and 1.27- μ m) diameter and length-to-diameter ratios between 150 and 250. Wires of these dimensions were chosen based on the experience of Aeronutronic Ford Corporation in similar testing environments. From the results of this investigation, it was determined that carefully prepared wires could be used in the Tunnel B test section with a favorable chance of survival. The preliminary study and subsequent test applications have demonstrated that one wire in three will survive for sufficient time for meaningful measurements.

An oven-calibration sequence is used to determine the behavior of sensor resistance with temperature and to infer effective sensor length. The heat-loss and recovery temperature characteristics of individual hot-wire probes are calibrated in the free-stream flow of the tunnel test section. A Reynolds number variation for the calibration is produced by varying tunnel stilling chamber pressure with nominally constant stilling chamber temperature.

7.0 OPTICAL-MECHANICAL TECHNIQUE FOR POSITIONING PROBES

Surveys of the relatively thin boundary layer on a blunt body in hypersonic flow require a method of determining probe position which has high precision. Probes of the

appropriate dimensions for thin layers can easily be damaged by vibrations of probe or model when the sensor is in close proximity to the surface. Moreover, the wire of an anemometer probe can be destroyed by the arcing which can occur with a system that depends on an electrical contact with the surface.

A technique has been devised which permits viewing the probe, in real-time, as it is positioned in close proximity to the model. The technique also permits measurements of the separation distance between probe and surface and allows the viewer to assess uncertainties associated with vibrations.

7.1 VIEWING SYSTEM

The survey probe position relative to the model surface is viewed using a high-resolution, closed-circuit television system. The television camera scans 1,225 horizontal lines (compared to 525 lines on a standard television camera), at a rate of 30 frames per second. A 15-in. (0.38-m) focal-length lens was modified to provide a 30-in. (0.76-m) effective focal-length telephoto-macro lens by the addition of a negative lens and an extension tube. This lens produces a magnification factor of 2.6 on the face of the camera vidicon tube with the lens located 34 in. (0.86 m) from the centerline of the wind tunnel test section. The television system electronically magnifies the image from the camera vidicon tube by a factor of 14.6 before displaying the image on a 14-in. (0.36-m) (diagonal) high-resolution monitor picture tube. This gives a total optical-electronic system magnification factor of 38. The primary lens, supplementary lens, and the camera are mounted on a common plate to provide a rigid support (Fig. 7).

The high-resolution television monitor is used for measurements of the magnified image of the probe and the model surface profile (Fig. 8). Measurements can be made on the face of the monitor picture tube with a transparent overlay having scale lines representing 0.001 in. (0.025 mm) at the centerline of the test section. Figure 8a is a photograph taken directly from the television monitor showing a 0.004-in. (0.1-mm) diameter pitot pressure probe near the surface of a model. The magnified silhouette of the model can also be used in estimating local surface roughness (Fig. 8b).

7.2 CAMERA MOUNT

The television camera and lens system are mounted on a heavy-duty motorized X-Y traversing table (Fig. 7). The table is isolated from tunnel vibrations by mounting it with the optics system which has a foundation separate from that of the tunnel. The camera can be positioned to view any point along the upper half of the model surface by using the table drive motors. The optical axis of the camera remains perpendicular to the axis

of the wind tunnel and on axis with the light source throughout its X-Y traversing range. The field of view at the centerline of the test section is approximately 0.2 by 0.3 in. (5 by 7.6 mm). As an aid in locating a particular area in the test section, a standard closed-circuit television camera with a normal focal-length lens is mounted adjacent to the high-resolution television camera and aligned on a common point at the centerline of the test section. An outline of the area covered by the high-resolution television system is indicated on the monitor screen for the standard television camera. The camera table can then be positioned using the outline. Subsequent fine adjustments of position are accomplished by viewing the high-resolution monitor.

7.3 LIGHT SOURCE

The continuous light source of the Tunnel B flow visualization system which provides an 18-in. (0.46-m) diameter collimated beam of light through the test section is used to backlight the model and probe (Fig. 9). This type of illumination provides a high-contrast silhouette of the probe and model for optimum resolution. The collimated light beam is aligned normal to the vertical plane of the model so that the probe, which traverses in the vertical plane, is always illuminated tangent to the top surface of the model. The view provided by the high resolution television monitor is an accurate representation of the probe position in relation to the top surface of the model.

8.0 DATA ACQUISITION AND REDUCTION

Flow-field data from the hot-wire probe are recorded on magnetic tape for subsequent reduction and analysis of the measurements. The typical magnetic tape recording of hot-wire response signals during a discrete-point traverse of a model boundary layer contains a five-second record for each setting of the hot-wire sensitivity at each point of the boundary-layer profile, using a tape speed of 120 in./sec (3.05 m/sec). If 10 measurement points are chosen along the traverse and 15 wire sensitivities are included at each point, one profile would produce 150 data records or approximately one full (9,600 ft (2.93 km)) reel of magnetic tape.

Figure 5 shows a block diagram of the instrumentation components for the recording of hot-wire response signals. The tape machine is set in the "record" mode at the desired transport speed. The first wire-heating current is selected, and the data interval timer is activated. When the timer completes the "valid data" interval, the second current is selected, and the timer is again activated. This procedure is continued until data for all desired wire-heating currents have been acquired. As the recording progresses, the quality of the data is continuously monitored on the spectrum analyzer to ensure that spurious signals are avoided. Concurrently, the rms level of the recorded signal is monitored on an X-Y plotter using the reproduce circuits of the tape machine. The analyzer and plotter traces

permit a real-time assessment of the nature of the sensor response and the quality of the signal.

The recovery of data from a magnetic tape record for signal processing becomes relatively inefficient if the playback speed is reduced below recording speed by more than a factor of two. The capabilities of the VKF data systems permit the recovery of the a-c and d-c components of the wire response voltage and the frequency spectrum of the a-c component at a tape playback rate of 60 in./sec (1.52 m/sec).

Reproduced signals from the tape recorder channels assigned to the a-c and d-c components are applied to the input of a multiplexed analog-to-digital converter. The a-c signals are routed through rms-to-dc converters before entering the multiplexer. The "valid data" signal is used to initiate a data acquisition routine wherein 250 to 1,000 samples of each channel are digitized and averaged for each data interval. The averages are presented in tabular form.

The reproduced a-c component of the wire voltage signal is applied to the input of the spectrum analyzer using the LF tuning section. The ordinate output (signal amplitude) of the analyzer is connected to a computer-controlled analog-to-digital converter. The abscissa output (frequency) is a function of analyzer scan time. The "valid data" signal is used to initiate the analyzer sweep and a data acquisition routine. Within the data routine, the analyzer ordinate output signal is sampled 20,000 times during the sweep, and the samples are stored on computer disk-storage in the form of 1,000 sums of 20 samples each. This procedure permits, for example, the frequency spectra of up to 150 sets of data contained on a 9,600-ft (2.93 km) reel of magnetic tape to be analyzed in 30 min with a real-time frequency scan of from 4 to 400 kHz and a bandwidth of 2 kHz and the results to be stored in digital form on a single disk for further processing.

Computer routines have been written to furnish a preliminary reduction of hot-wire measurements which permit evaluation of the turbulent fluctuation intensities and assessment of data quality during the testing. The data reduction procedures used are those discussed by Morkovin in Ref. 7. Corrections of the signal to account for the limited frequency response of the anemometer system, such as those set forth in Ref. 8, will be included in future expansions of the data handling capabilities.

Typical hot-wire anemometer data are presented in Figs. 10 through 12 to illustrate the type of results obtained in the experiments conducted in cooperation with Aeronutronic Ford Corporation (Ref. 2 through 5). A qualitative survey of the boundary layer on a blunt body (Ref. 2) gave the results presented in Fig. 10. The rotary actuator used to sweep the hot-wire anemometer through the layer as indicated in the figure is briefly described in Section 4.0. A series of qualitative surveys of the boundary layer on a sharp

cone (Ref. 5) is presented in Fig. 11. Pitot pressure and total temperature profiles (not shown) were also acquired to determine the mean-flow conditions across the layer. Quantitative hot-wire anemometer measurements obtained in discrete-point surveys of a sharp cone boundary layer (Ref. 5) are shown in Fig. 12, reduced to the form of velocity and temperature fluctuations.

9.0 CONCLUSIONS

The wind tunnel test capabilities of the von Kármán Gas Dynamics Facility have been extended by the assembly of equipment and development of techniques for making hot-wire anemometer measurements in boundary layers on models of hypersonic flight vehicles. Provisions have been made for the fabrication and calibration of hot-wire anemometer probes required for the test environment. Data handling techniques have been developed which permit efficient assessment of data quality during testing. Optical and mechanical devices have been assembled which allow determination of probe position relative to the model surface with a precision consistent with requirements for the thin layers investigated.

REFERENCES

1. Donaldson, J. C. and Wallace, J. P. "Flow Fluctuation Measurements at Mach Number 4 in the Test Section of the 12-Inch Supersonic Tunnel (D)." AEDC-TR-71-143 (AD728630), August 1971.
2. Demetriades, A. and Laderman A. J. "Boundary-Layer Transition in High-Gradient Regions." Part 2 of "Final Report, Volume I, Advanced Penetration Problems Program." SAMSO TR No. 75-51, December 1974.
3. Laderman, A. J. "Effect of Mass Addition on the Boundary Layer over a Smooth-Wall Hemispherical Blunt Body at $M_\infty = 6$." Aeronutronic Ford Corporation Publication No. U-6160, August 1975.
4. Laderman, A. J. "Effect of Mass Addition and Angle-of-Attack on the Hypersonic Boundary Layer Turbulence over a Slender Cone." Philco-Ford Corporation Publication No. U-6047, September 1973.
5. Demetriades, A. "Hydrodynamic Stability and Transition to Turbulence in the Hypersonic Boundary Layer over a Sharp Cone." Aeronutronic Ford Corporation Publication No. U-6139, April 15, 1975.

6. Doughman E. L. "Development of a Hot-Wire Anemometer for Hypersonic Turbulent Flows." The Review of Scientific Instruments, Vol. 43, No. 8, August 1972, pp. 1200-1202.
7. Morkovin, Mark V. "Fluctuations and Hot-Wire Anemometry in Compressible Flows." AGARDograph 24, November 1956.
8. Laderman, A. J. and Demetriades A. "Turbulence Measurements in the Hypersonic Boundary Layer over a Cooled Wall." Philco-Ford Corporation Publication No. U-5079, September 1972.

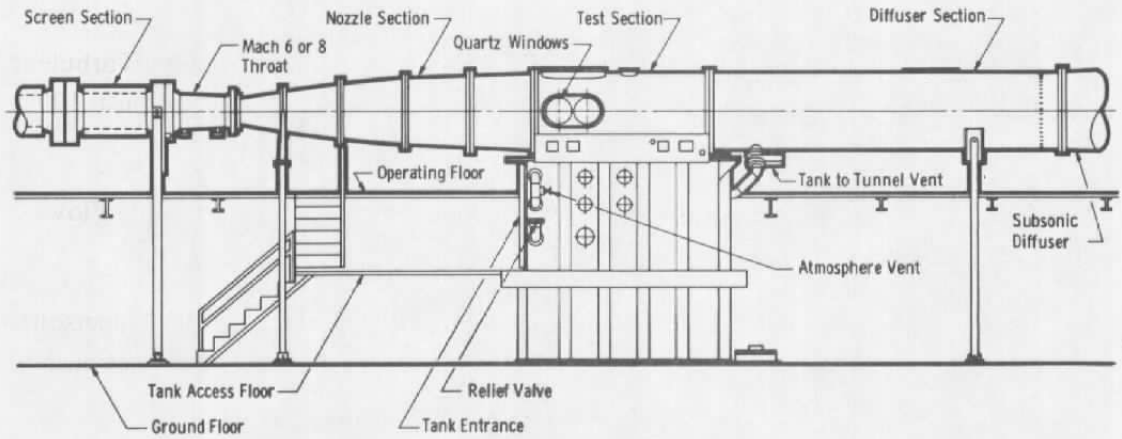

a. Tunnel assembly

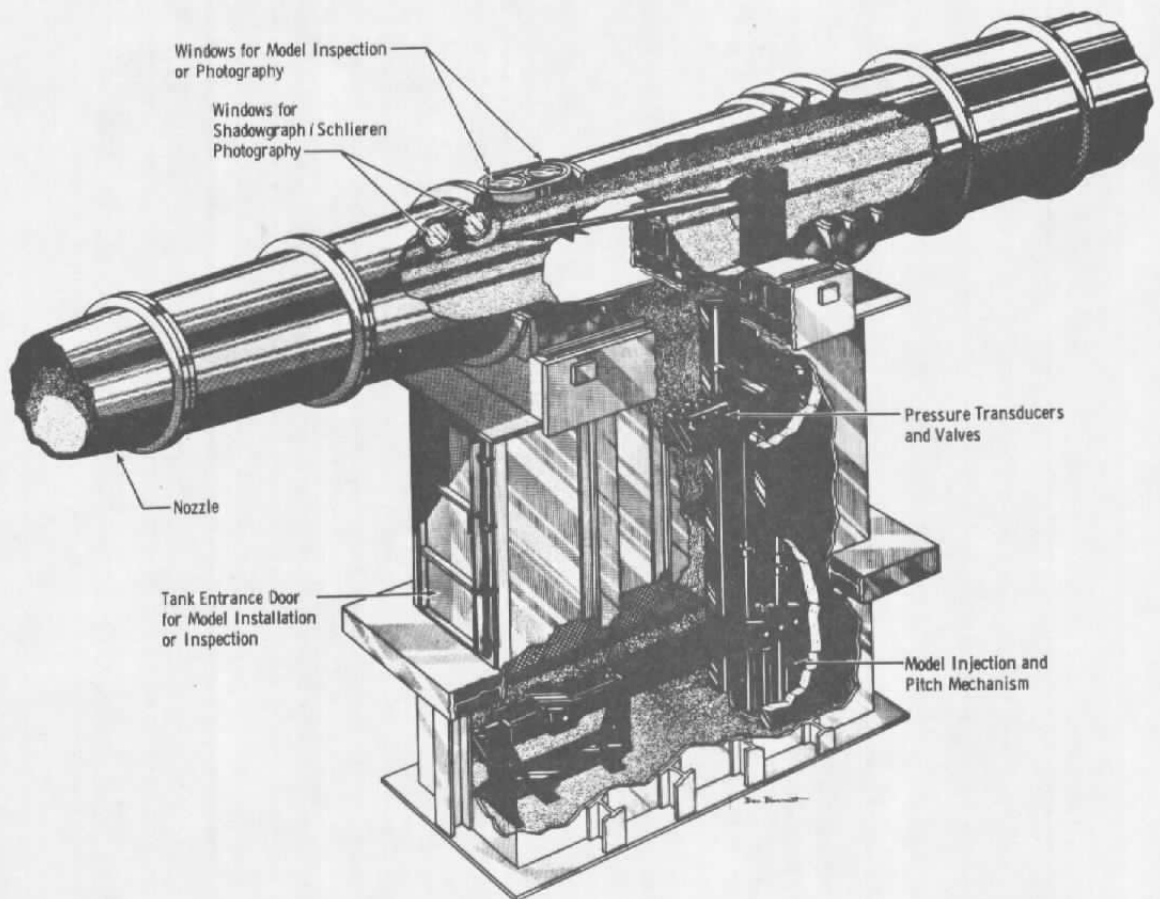

b. Tunnel test section
Figure 1. Tunnel B.

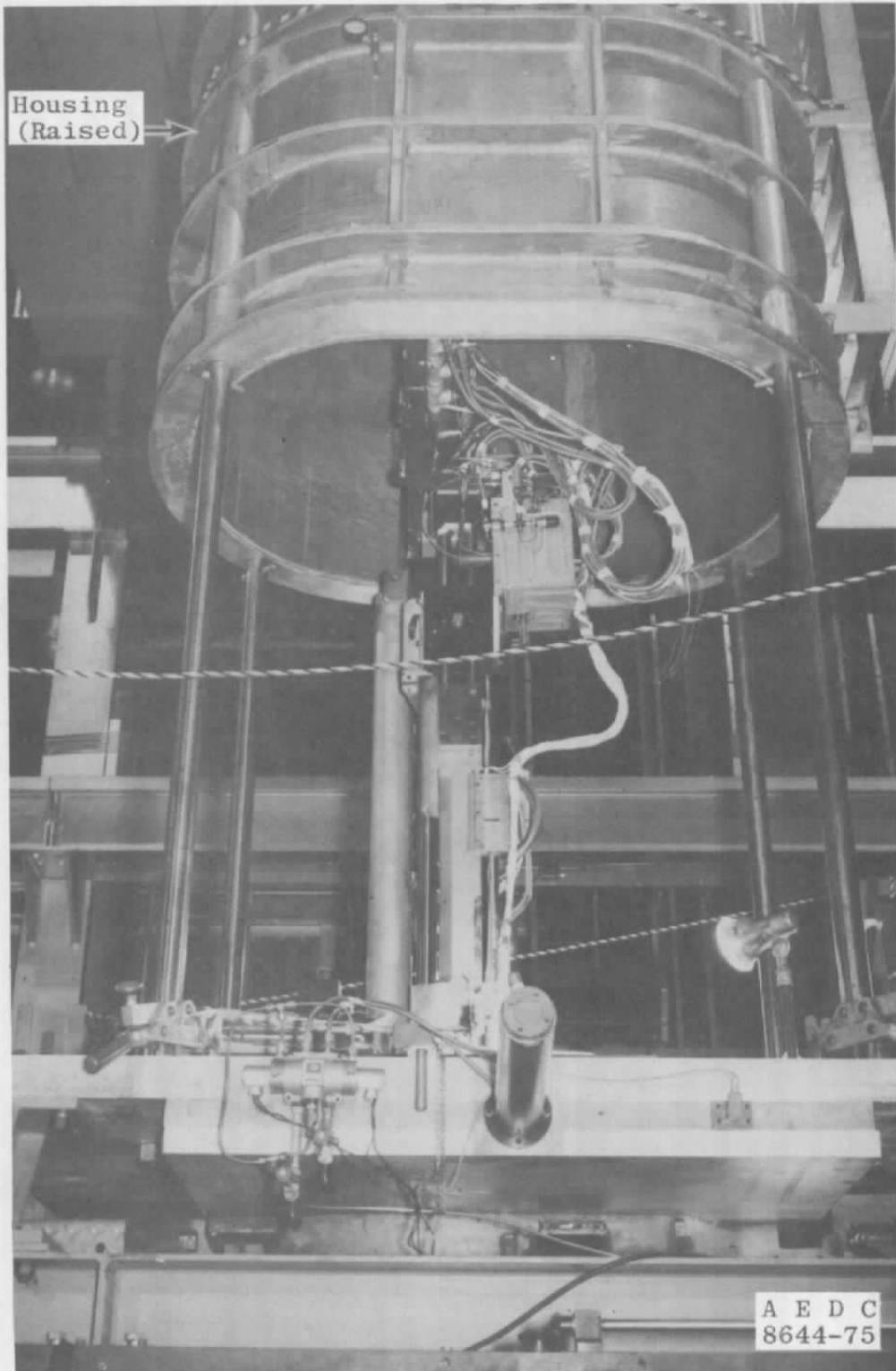
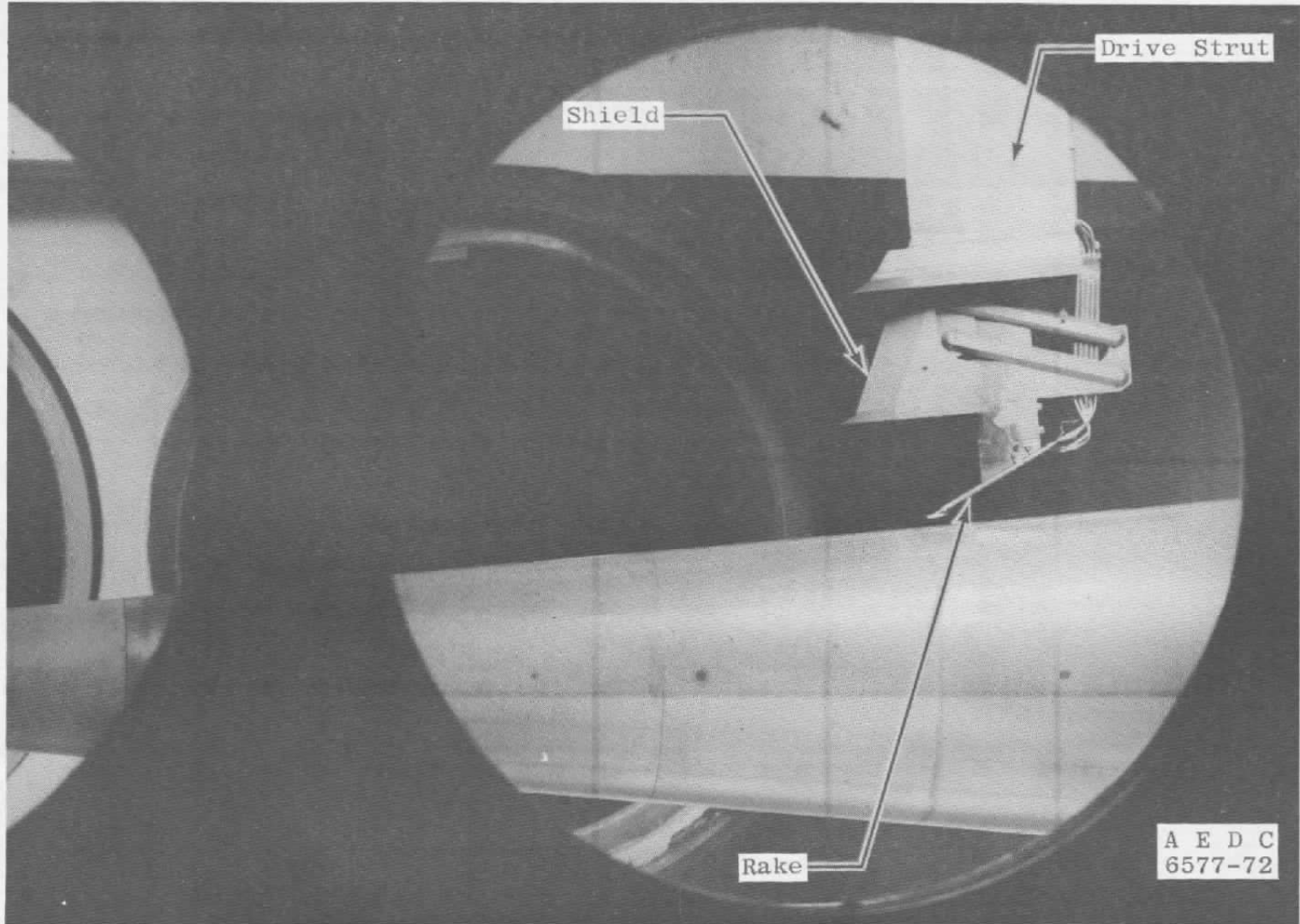
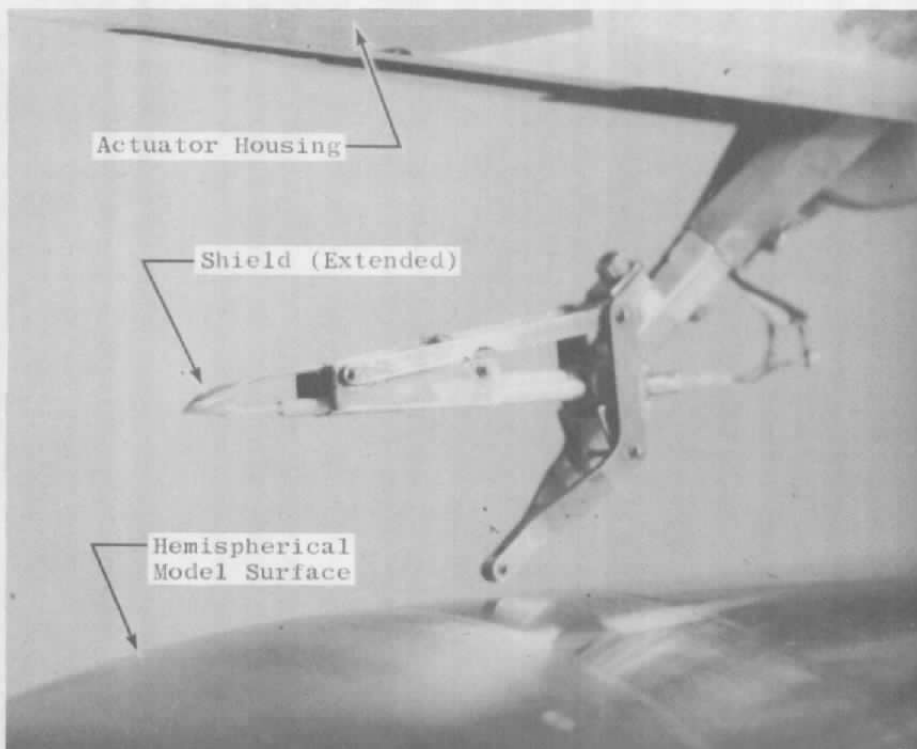

Figure 2. Probe drive mechanism.



RIS

a. Multi-probe rake, remotely actuated shield
Figure 3. Typical survey probe assemblies.



b. Hot-wire anemometer probe, mechanically actuated shield
Figure 3. Concluded.

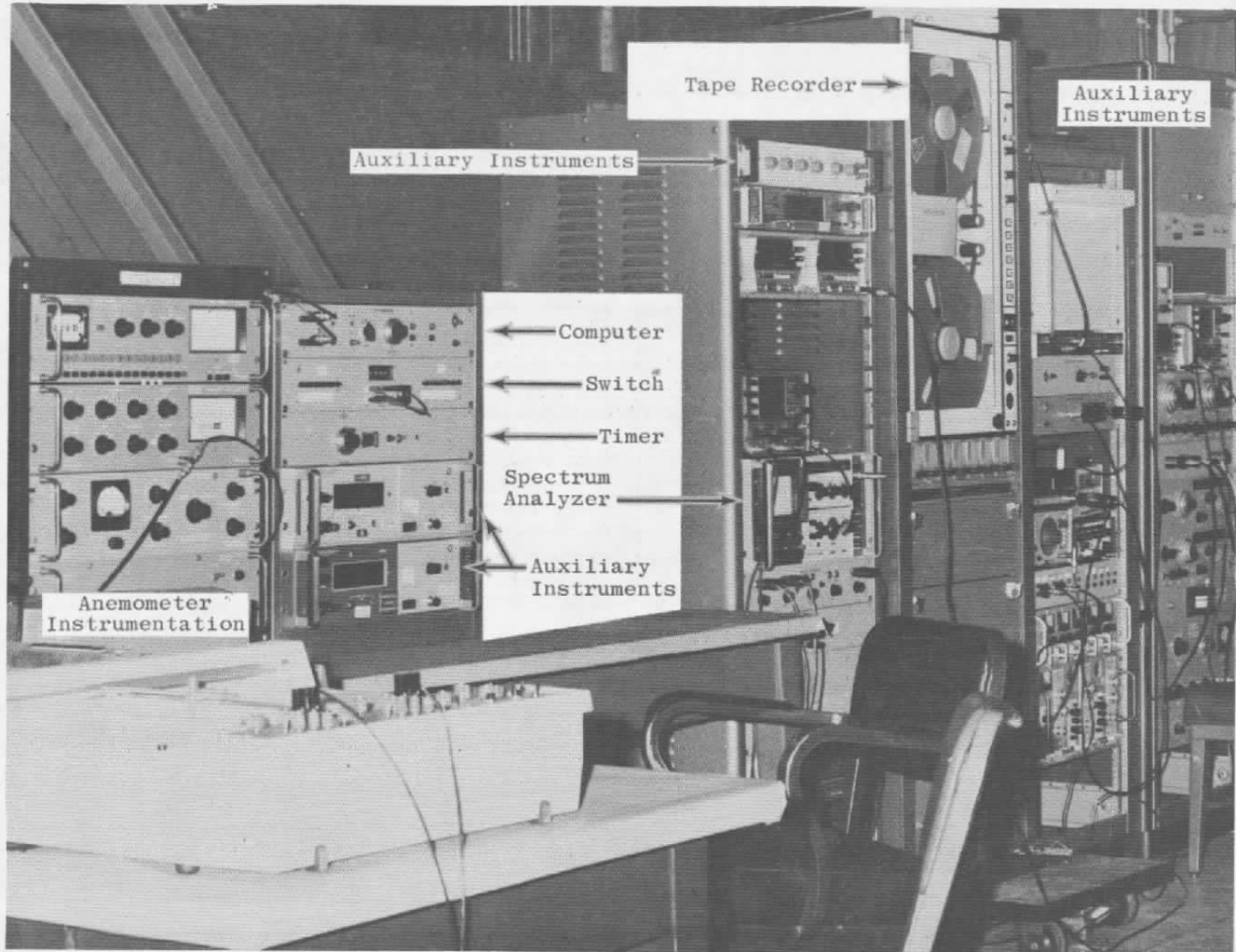

Figure 4. Assembled instrumentation.

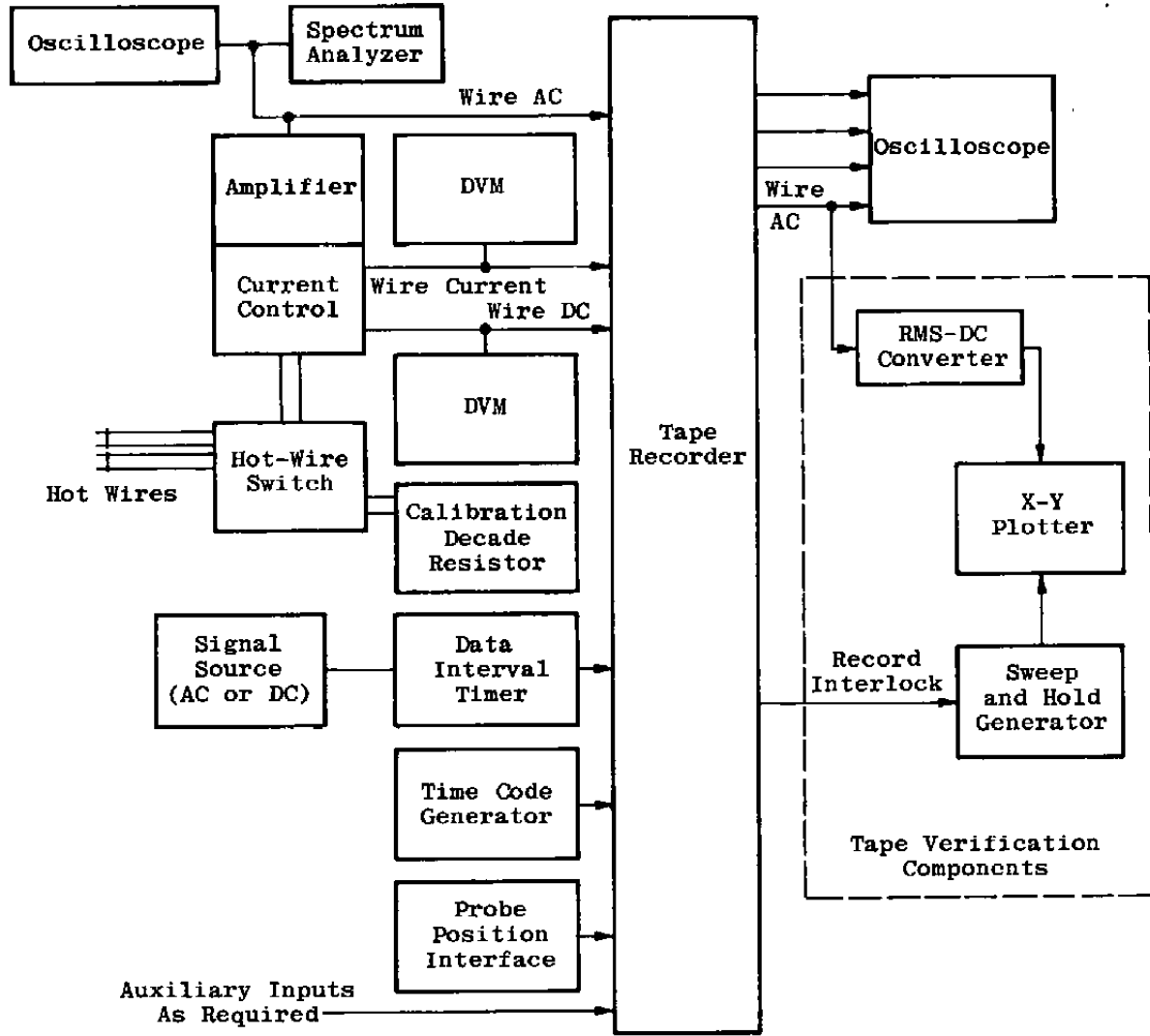

Figure 5. Hot-wire measurements instrumentation in the data record mode.

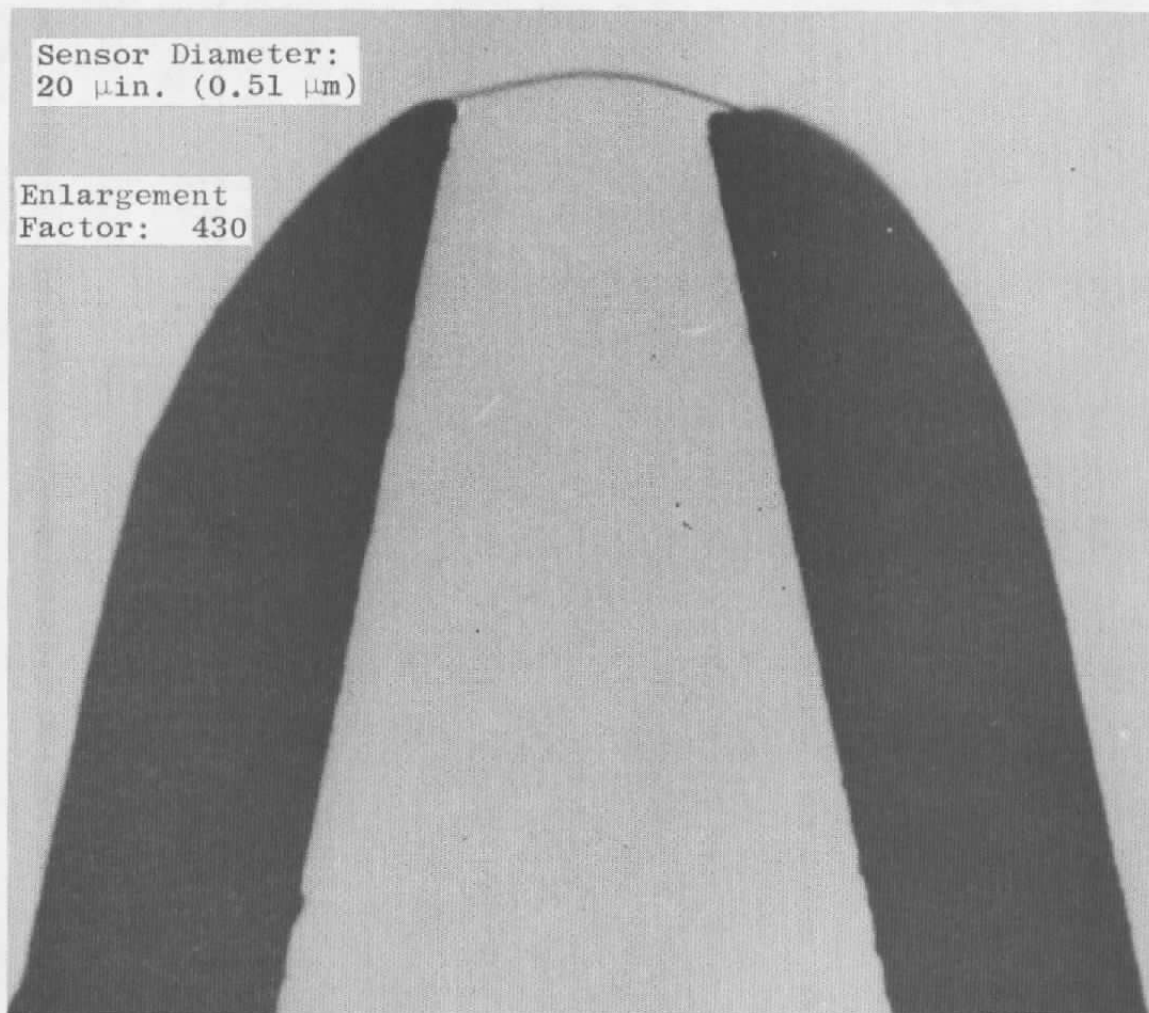

Figure 6. Silhouette photograph of a typical fine-wire mounting.

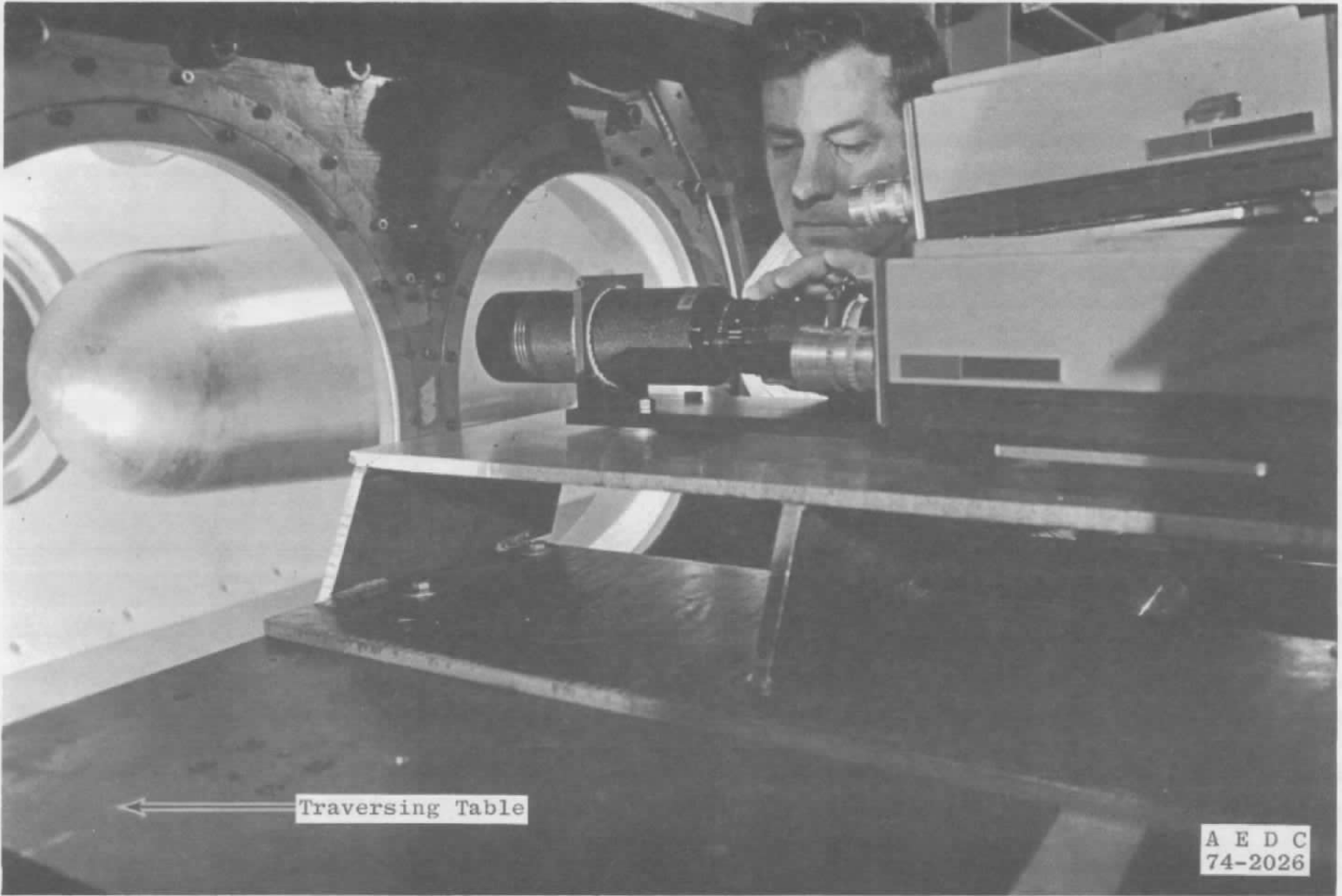
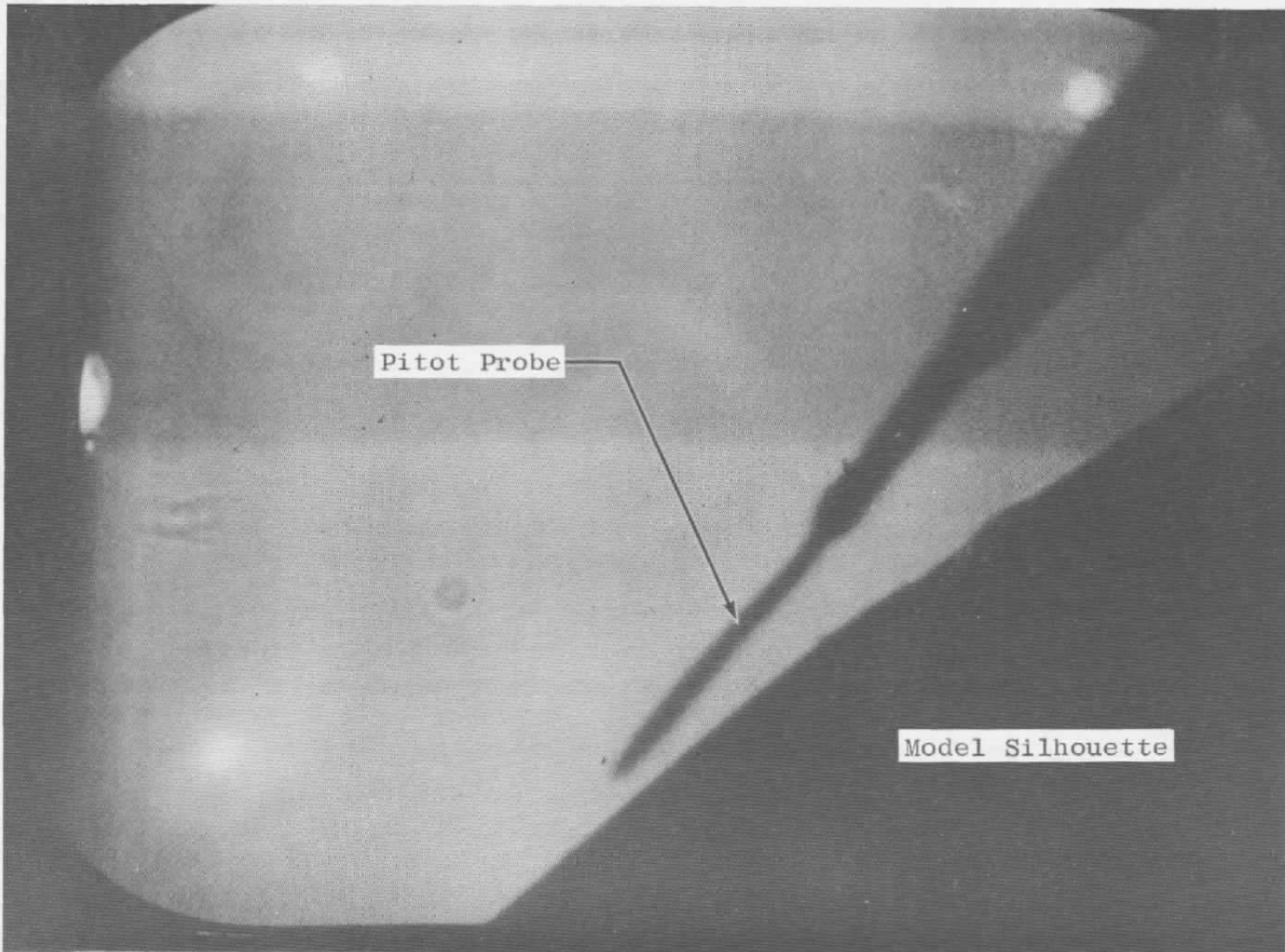
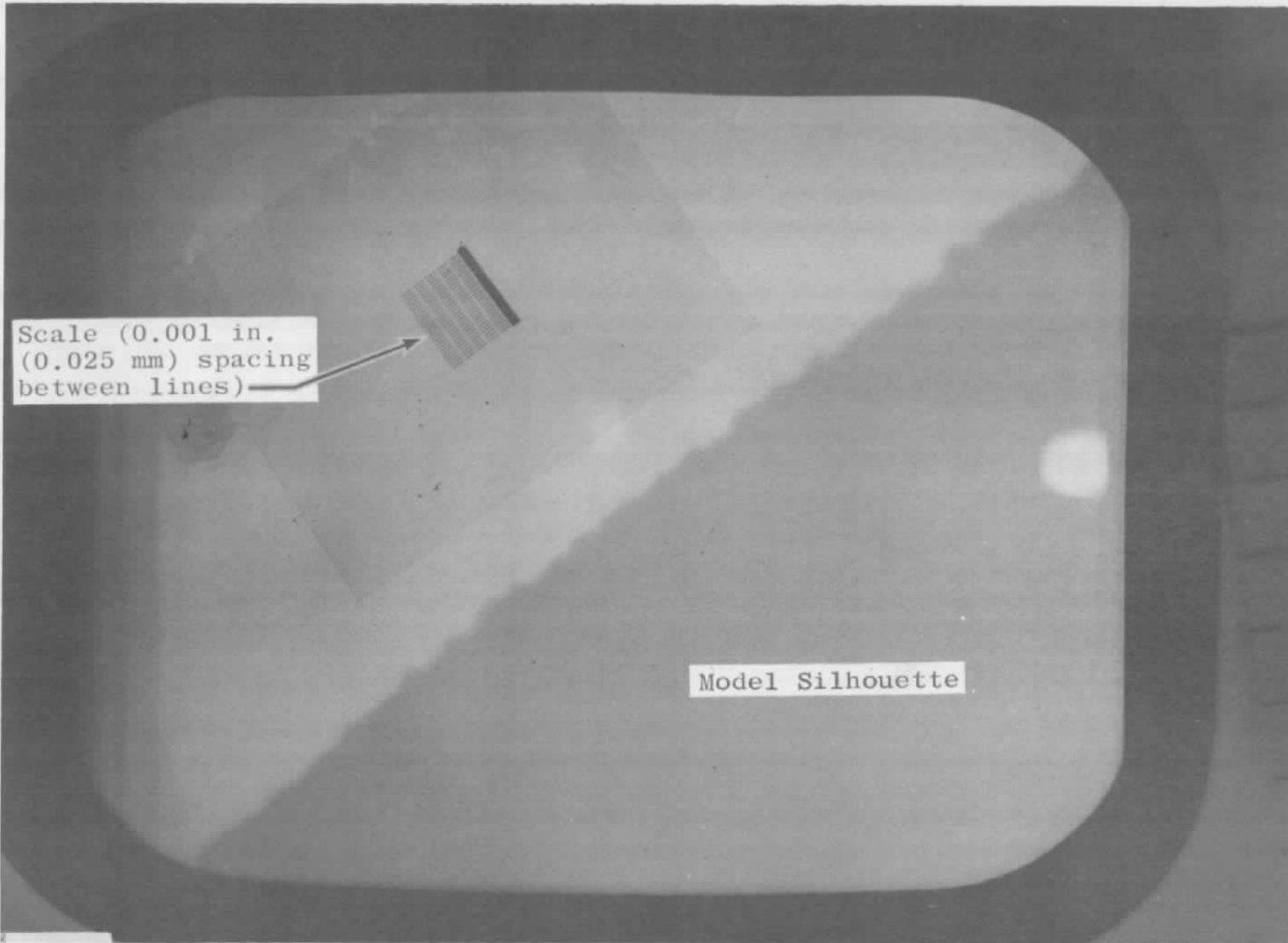

Figure 7. Television cameras and mount.



a. Pitot pressure probe near surface
Figure 8. High-resolution television images.



Scale (0.001 in.
(0.025 mm) spacing
between lines)

Model Silhouette

b. Model surface profile with roughness
Figure 8. Concluded.

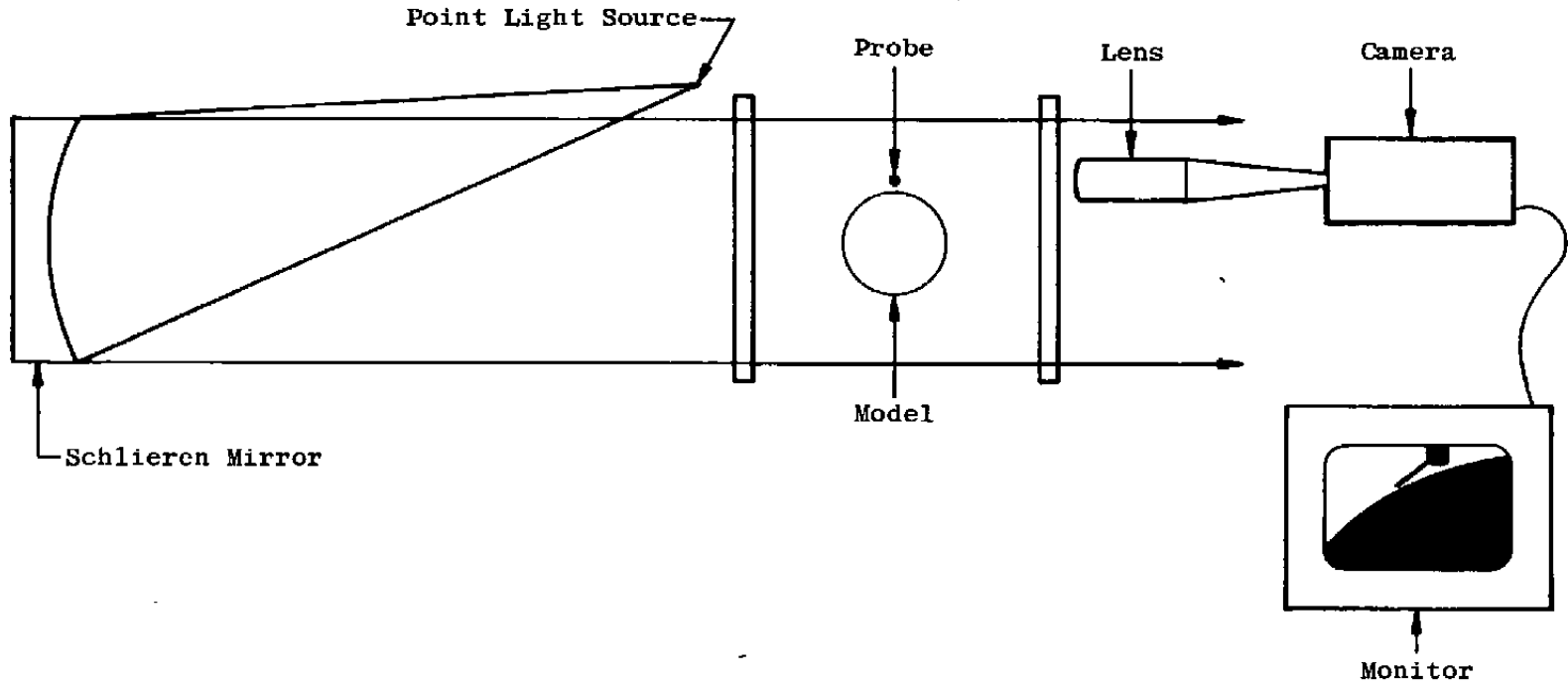
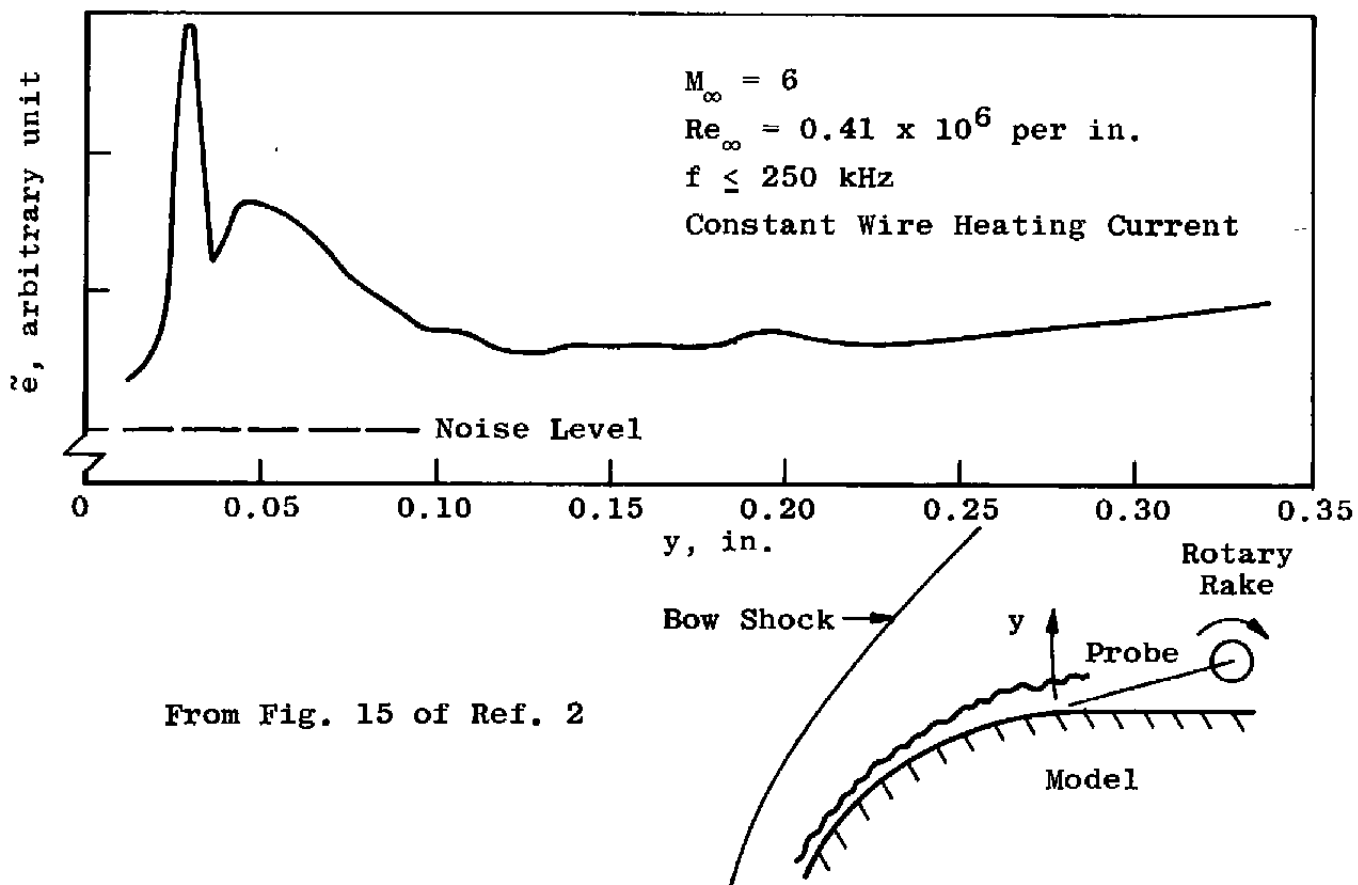

Figure 9. Video and light source system.



From Fig. 15 of Ref. 2

Figure 10. Typical qualitative hot-wire anemometer response signal from a survey through the boundary layer on a blunt body.

$M_\infty = 8$

$Re_\infty = 0.14 \times 10^6$ per in.

Zero Angle of Attack

\tilde{e} is in arbitrary units

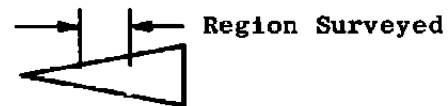

From Fig. 21 of Ref. 5

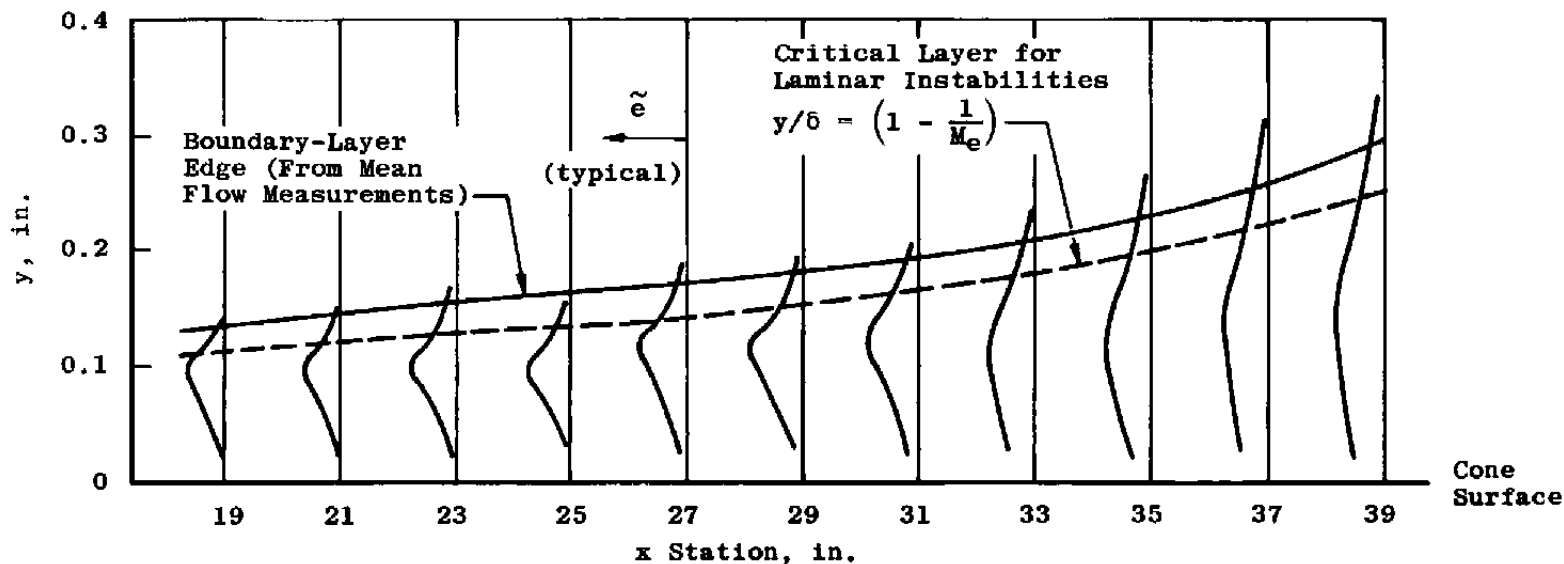

Figure 11. Typical qualitative hot-wire anemometer signal map from surveys of the boundary layer on a sharp cone.

From Fig. 10 of Ref. 5

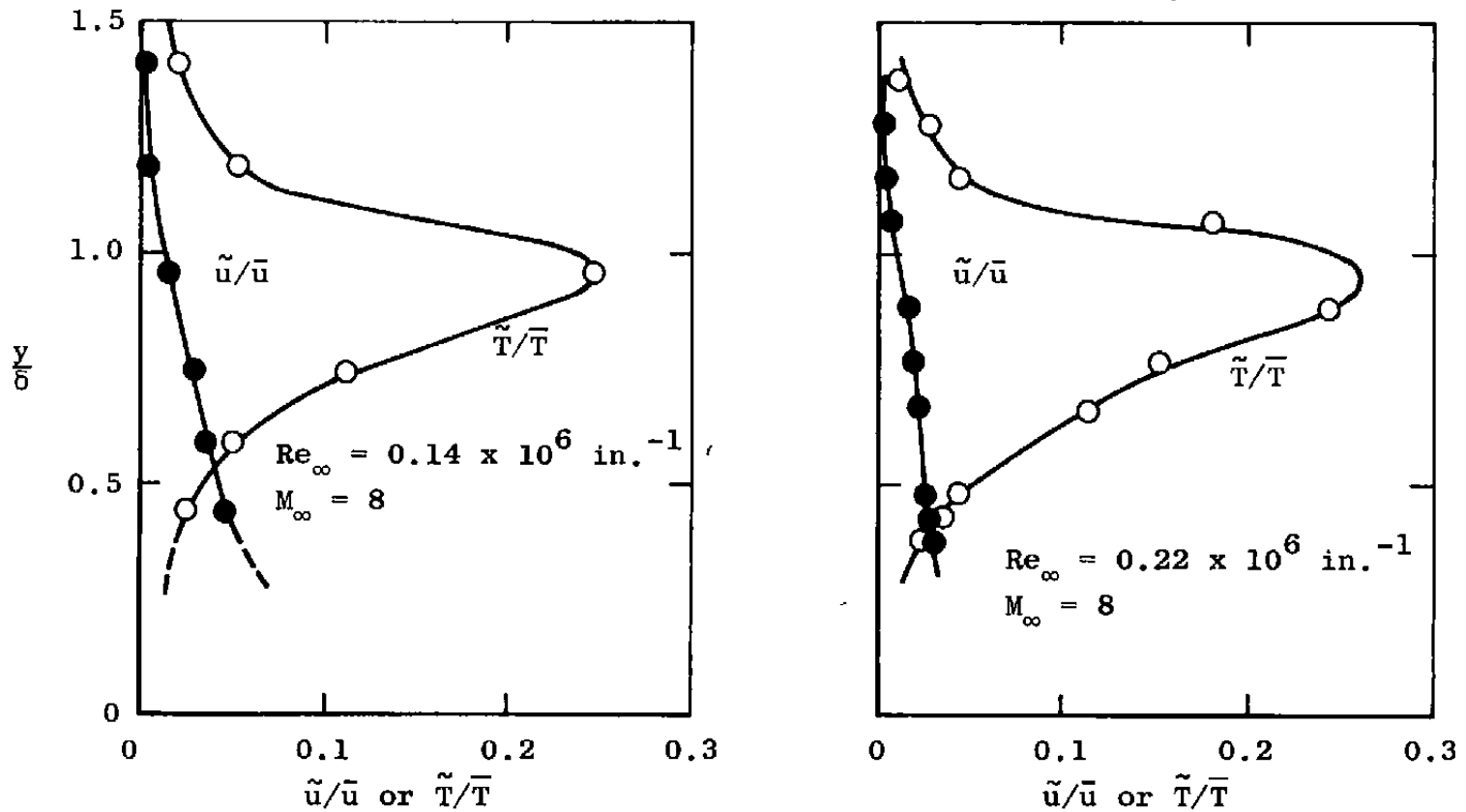

Figure 12. Typical variations of velocity and temperature fluctuations across the boundary layer of a sharp cone at zero angle of attack.

NOMENCLATURE

e	Hot-wire anemometer a-c output, arbitrary unit
f	Frequency, Hz
M	Mach number
Re	Unit Reynolds number, in. ⁻¹
T	Temperature, °R
u	Flow velocity, ft/sec
x	Axial distance from nosetip of model, in.
y	Distance from surface of model, in.
δ	Thickness of boundary layer on model, in.

SUBSCRIPTS

e	At boundary layer edge
∞	In free stream

SUPERSCRIPTS

(~)	Root mean square (rms) value of fluctuating quantity
($\bar{\quad}$)	Mean value, average with respect to time