

AD-A031 066

LTV AEROSPACE CORP DALLAS TEX VOUGHT SYSTEMS DIV F/G 1/3
S-3A GRAPHITE/EPOXY SPOILER DEVELOPMENT PROGRAM. VOLUME II.(U)

JUL 75 E G BLOSSER, S A MCGOVERN, O E DHONAU N62269-73-C-0610
2-53443/4R-3172-VOL-2 NADC-75141-30 NL

UNCLASSIFIED

1 OF 1
AD
A031066

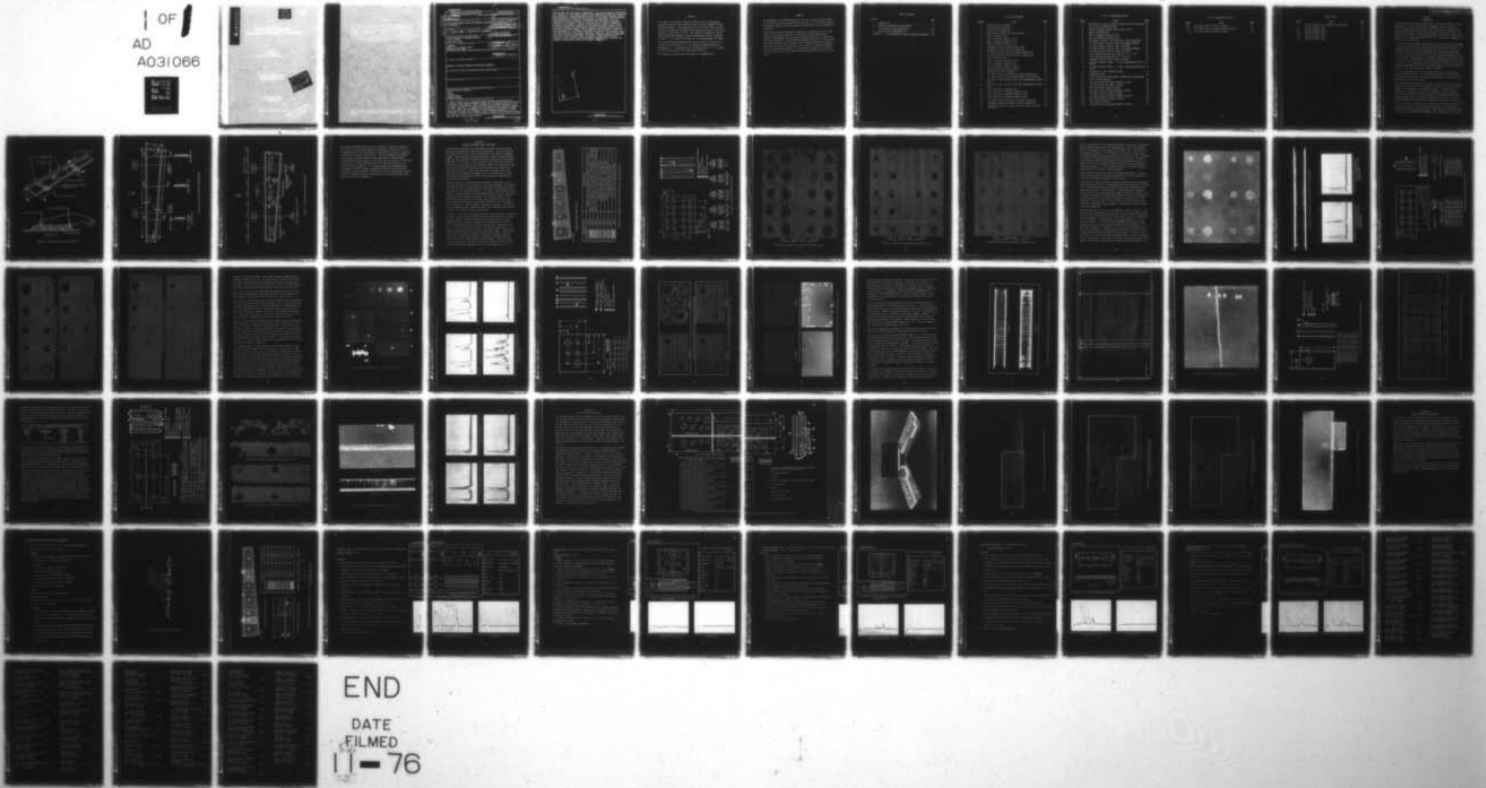

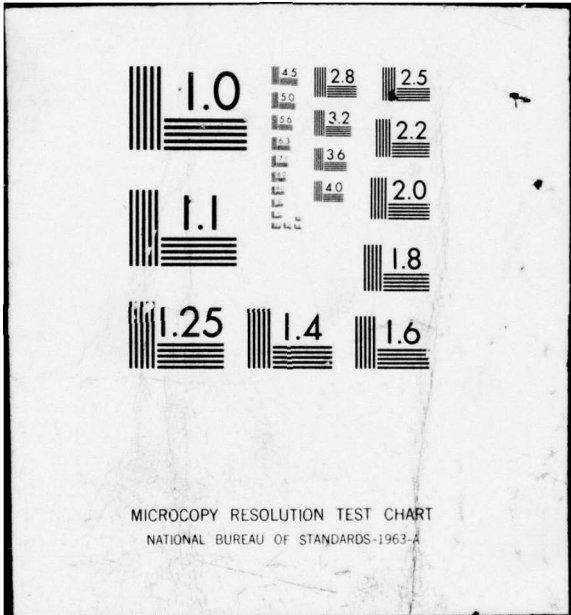

UNCLASSIFIED

SECURITY CLASSIFICATION OF THIS PAGE (When Data Entered)

19 REPORT DOCUMENTATION PAGE		READ INSTRUCTIONS BEFORE COMPLETING FORM	
18 1. REPORT NUMBER NADC-75141-30	2. GOVT ACCESSION NO.	9 3. RECIPIENT'S CATALOG NUMBER	
6 4. TITLE (and Subtitle) S-3A Graphite/Epoxy Spoiler Development Program, (Volume II)		5. TYPE OF REPORT & PERIOD COVERED Final Technical Report, Jun 74 to Jul 75	
7. AUTHOR(s) 10 E. G. Blosser, S. A. McGovern, O. E. Dhenau		14 6. PERFORMING ORG. REPORT NUMBER 2-53443/4R-3172-Vol-2	
9. PERFORMING ORGANIZATION NAME AND ADDRESS Vought Corporation (Systems Division) P. O. Box 5907 Dallas, TX 75222		15 8. CONTRACT OR GRANT NUMBER(s) N62269-73-C-0610	
11. CONTROLLING OFFICE NAME AND ADDRESS Commander Naval Air Development Center Warminster, PA 18974		11 10. PROGRAM ELEMENT PROJECT, TASK AREA & WORK UNIT NUMBERS 12 11. REPORT DATE Jul 1975	
14. MONITORING AGENCY NAME & ADDRESS (if different from Controlling Office)		12 12. NUMBER OF PAGES 58	
15. SECURITY CLASS. (of this report) UNCLASSIFIED		15a. DECLASSIFICATION/DOWNGRADING SCHEDULE	
16. DISTRIBUTION STATEMENT (of this Report) <p style="text-align: center;">Approved for Public Release; distribution unlimited</p>			
17. DISTRIBUTION STATEMENT (of the abstract entered in Block 20, if different from Report)			
18. SUPPLEMENTARY NOTES			
19. KEY WORDS (Continue on reverse side if necessary and identify by block number) Non-destructive inspection S-3A Spoiler Graphite/epoxy Composite Repair			
20. ABSTRACT (Continue on reverse side if necessary and identify by block number) <p>After testing of the S-3A Graphite/Epoxy Spoilers was satisfactorily completed, under Contract N62269-73-C-0610, the contracted effort was extended to include the development of NDI standards for the composite spoiler to be included in Volume II. In addition to the fabrication of reference standards for this report, the development of field inspection techniques was pursued using the ultrasonic unit available to Navy inspection personnel. A Sonic Instruments ultrasonic unit (Federal Stock No. 6RX6635-070-6669-SXTX) borrowed</p>			

DD FORM 1 JAN 73 1473

EDITION OF 1 NOV 65 IS OBSOLETE
S/N 0102-014-6601

UNCLASSIFIED

SECURITY CLASSIFICATION OF THIS PAGE (When Data Entered)

408116

JB

UNCLASSIFIED

SECURITY CLASSIFICATION OF THIS PAGE (When Data Entered)

from the Navy was used in this investigation. The initial phase of developing NDI standards for the composite spoiler was accomplished through the fabrication and evaluation of eleven experimental Quality Control Defect Specimens (QCDS). These preliminary reference panels were built to investigate the best material for producing built-in defects, the minimum detectable defect size, the influence of varying the number of skin plies, the influence on attenuation properties of the amount of resin in honeycomb cells, and the influence on attenuation and physical properties of the amount of bleeder material used. The final standards were designed utilizing the information gained from the preliminary reference panels. These standards were fabricated in triplicate with two panels to be furnished to the Navy for field use and one panel to be retained by VSD for use in future production inspection. All reference panels were characterized by radiography, ultrasonic through transmission (immersion and contact) and ultrasonic pulse-echo methods. Procedures for field inspection using contact ultrasonic through transmission were developed and complete technique data sheets are included as Appendix A.

ADDITIONAL FOR

NTIS White Ensign
D/C DAY 20-10

UNCLASSIFIED
JUSTIFICATION

BY _____
DISTRIBUTION/AVAILABILITY

SIGNATURE _____
DATE _____

AI

UNCLASSIFIED

SECURITY CLASSIFICATION OF THIS PAGE (When Data Entered)

FOREWARD

This report was prepared by Vought Systems Division of LTV Aerospace Corporation, Dallas, Texas under the terms of contract N62269-74-C-0610 (Amendment P00006). This supplement to the final report covers the NDI standard and inspection procedures work accomplished during the period of January 2, 1975 to July 10, 1975. The program was sponsored by the Air Vehicle Technology Department, Naval Air Development Center, Warminster, PA 18974. Mr. A. Manno, Code 30334, was the program manager for NADC.

The following Vought Systems Division personnel were the principal contributors to the program: Mr. E. G. Blosser, Advanced Manufacturing Technology; Dr. S. A. McGovern, Quality Assurance, NDI. Mr. O. E. Dhonau was the Project Engineer for Vought Systems Division.

This report was prepared under VSD Report No. 2-53443/4R-3172.

SUMMARY

The development of the graphite/epoxy spoilers for the S3A aircraft brought on the need for inspection capability in the field. As a part of the contract a program to develop inspection standards and techniques for this purpose was undertaken.

Preliminary specimens were defined, developed, and evaluated prior to preparation of the selected standards. The spoiler was zoned according to structural requirements and the need for specimen definition to inspect each zone was investigated. Ten preliminary specimens were used in this evaluation. As a result of these investigations a final standard specimen was designed, containing four types of construction which simulated the spoiler structure, and which contained known defects. A procedure for comparative evaluation of the standard and an actual spoiler was then prepared for each of the four areas.

TABLE OF CONTENTS

SECTION	PAGE
1 INTRODUCTION	1
2 REFERENCE STANDARD PANEL DEVELOPMENT	6
3 FINAL REFERENCE PANEL FABRICATION	35
4 CONCLUSIONS AND RECOMMENDATION	42
APPENDIX A S3A GRAPHITE/EPOXY SPOILER INSPECTION PROCEDURE .	43

LIST OF ILLUSTRATIONS

<u>Figure</u>	<u>Title</u>	<u>Page</u>
1	COMPOSITE SPOILER ASSEMBLY	2
2	SPOILER GENERAL DIMENSIONS	3
3	CORE AND SKIN ARRANGEMENT	4
4	GRAPHITE/EPOXY STRUCTURAL ZONE DEFINITION	7
5	QCDS-2 SPECIMEN DETAIL	8
6	QCDS-2 ULTRASONIC RECORD AT X1+3	9
7	QCDS-2 ULTRASONIC RECORD AT X1+6	10
8	QCDS-2 ULTRASONIC RECORD AT X1+8	11
9	RADIOGRAPH OF QCDS-2 SPECIMEN (PLAN VIEW)	12
10	RADIOGRAPH OF QCDS-2 SPECIMEN (EDGE VIEW)	13
11	CRT SCOPE DISPLAY OF QCDS-2 SPECIMEN IN NORMAL AREA	13
12	CRT SCOPE DISPLAY OF QCDS-2 SPECIMEN IN DEFECT AREA	13
13	QCDS-3 SPECIMEN DETAIL	15
14	QCDS-3 ULTRASONIC RECORD AT X0.1+2	16
15	QCDS-3 ULTRASONIC RECORD AT X1+3	16
16	QCDS-3 ULTRASONIC RECORD AT X10+0.4	17
17	QCDS-3 ULTRASONIC RECORD AT X10+MAX	17
18	RADIOGRAPH OF DEFECT SPECIMENS	18
19	CRT SCOPE DISPLAY FOR PULSE-ECHO ON QCDS-3 NORMAL AREA	19
20	CRT SCOPE DISPLAY FOR PULSE-ECHO ON QCDS-3 IN DEFECT AREA	19
21	CRT SCOPE DISPLAY FOR QCDS-3 WITH THRU TRANSMISSION IN NORMAL AREA	19
22	CRT SCOPE DISPLAY FOR QCDS-3 WITH THRU TRANSMISSION IN DEFECT AREA	19
23	QCDS-4 AND QCDS-5 SPECIMEN DETAIL	21
24	QCDS-4 AND QCDS-5 ULTRASONIC RECORD AT X10+1	22
25	QCDS-4 AND QCDS-5 ULTRASONIC RECORD AT X10+2	22
26	QCDS-4 AND QCDS-5 ULTRASONIC RECORD AT X10+6	23
27	RADIOGRAPH OF QCDS-4 AND QCDS-5 SPECIMENS (PLAN VIEW)	23
28	RADIOGRAPH OF QCDS-4 AND QCDS-5 SPECIMENS (EDGE VIEW)	24
29	ULTRASONIC RECORD OF #2 STATIC SPOILER IN AREA OF SKIN PLY VARIATION	25

LIST OF ILLUSTRATIONS (CONT'D)

<u>Figure</u>	<u>Title</u>	<u>Page</u>
30	RADIOGRAPH OF #2 STATIC SPOILER IN AREA OF SKIN PLY VARIATION	26
31	QCDS-6 THRU -10 SPECIMEN DETAIL	28
32	ULTRASONIC RECORD OF QCDS-6 THRU -10 AT X0.1+0.4	29
33	QCDS-11 SPECIMEN DETAIL	30
34	QCDS-11 ULTRASONIC RECORD AT X1+7	32
35	QCDS-11 ULTRASONIC RECORD AT X10+1	32
36	RADIOGRAPH'S OF QCDS-11 SPECIMEN (PLAN VIEW AND END VIEW)	33
37	CRT SCOPE DISPLAY OF QCDS-11 AREA 1 FOR NORMAL COMPONENT	34
38	CRT SCOPE DISPLAY OF QCDS-11 AREA 1 FOR DEFECT	34
39	CRT SCOPE DISPLAY OF QCDS-11 AREA 2 FOR NORMAL COMPONENT	34
40	CRT SCOPE DISPLAY OF QCDS-11 AREA 2 FOR DEFECT	34
41	FINAL STANDARD SPECIMEN DETAIL (QCDS-12, -13, & -14)	36
42	FINAL STANDARD SPECIMENS QCDS-12, -13, AND -14	37
43	ULTRASONIC RECORD OF AREA 4 (SOLID LAMINATE)	38
44	ULTRASONIC RECORD OF AREAS 1, 2, AND 3 (HONEYCOMB AND TAB) AT X10+3.6	39
45	ULTRASONIC RECORD OF AREAS 1, 2, AND 3 (HONEYCOMB AND TAB) AT X10+5	40
46	RADIOGRAPH OF FINAL STANDARD SPECIMEN	41
A-1	TRANSDUCER HOLDER	44
A-2	SPOILER INSPECTION ZONE/REFERENCE STANDARD AREA COORDINATION	45
A-3	AREA 1 DEFECT LOCATIONS	46
A-4	CRT SCOPE DISPLAY FOR NORMAL RESPONSE IN AREA 1	46
A-5	CRT SCOPE DISPLAY FOR DEFECT IN AREA 1	46
A-6	AREA 2 AND AREA 3 DEFECT LOCATIONS	47
A-7	CRT SCOPE DISPLAY OF NORMAL RESPONSE IN AREA 2	47
A-8	CRT SCOPE DISPLAY OF DEFECT IN AREA 2	47
A-9	CRT SCOPE DISPLAY FOR NORMAL RESPONSE IN AREA 3	48
A-10	CRT SCOPE DISPLAY FOR DEFECT IN AREA 3	48
A-11	AREA 4 DEFECT LOCATION	49
A-12	CRT SCOPE DISPLAY FOR NORMAL RESPONSE IN AREA 4	49

LIST OF ILLUSTRATIONS (CONT'D)

<u>Figure</u>	<u>Title</u>	<u>Page</u>
A-13	CRT SCOPE DISPLAY FOR DEFECT IN AREA 4	49
A-14	CRT SCOPE DISPLAY FOR NORMAL RESPONSE IN AREA 4	50
A-15	CRT SCOPE DISPLAY FOR DEFECT IN AREA 4	50

LIST OF TABLES

<u>Table</u>	<u>Title</u>	<u>Page</u>
I	EFFECT OF BLEEDING ON THICKNESS AND FIBER VOLUME	27
A-I	MACHINE SETTINGS AREA 1	46
A-II	MACHINE SETTINGS AREA 2	47
A-III	MACHINE SETTINGS AREA 3	48
A-IV	MACHINE SETTINGS AREA 4	49
A-V	MACHINE SETTINGS AREA 4	50

SECTION 1 INTRODUCTION

The S-3A spoilers are surfaces hinged off the rear spar of the wing. They function as roll control devices and speedbrakes. Each wing has four spoilers, three upper and one lower. The lower spoiler is located on the wing underside, and is a simple beam supported by two hinge fittings. The spoiler is positioned by a push rod attached to each fitting. The spoiler is quadrilateral in shape, approximately 80" long, 8" wide at the outboard and 15" wide at the inboard end.

A composite spoiler assembly composed of only four basic parts was designed as a direct replacement for the existing lower metal spoiler assembly. The complete assembly, including the trailing edge seal is shown in Figure 1. The composite spoiler fits in the same space as the existing lower metal spoiler, is hinged off the existing outer panel rear spar supports, and utilizes the same actuation system. The general dimensions are shown in Figure 2. The spoiler is composed of two contoured graphite/epoxy skins of variable thickness, a glass reinforced plastic honeycomb core, and two existing metal hinge fittings attached with fourteen bolts threaded into inserts potted in the core. The skin arrangement is shown in Figure 3.

The S-3A Graphite/Epoxy Spoiler Development Program was conducted under Contract N62269-73-C-0610. Five graphite/Epoxy spoilers were fabricated. One was sectioned to evaluate processes and manufacturing, three were static tested and one was fatigue tested.

After testing was satisfactorily completed, all allotted funds had not been spent; so VSD applied for an extension of the contract to include the development of NDI standards for the composite spoiler. In addition to the fabrication of reference standards, the development of field inspection techniques was pursued using the ultrasonic unit available to Navy inspection personnel. A Sonic Instruments ultrasonic unit (Federal Stock No. 6RX6635-070-6669-SXTX) borrowed from the Navy was used in this investigation.

The initial phase of developing NDI standards for the composite spoiler was accomplished through the fabrication and evaluation of ten experimental Quality Control Defect Specimens (QCDS). These preliminary reference panels were built to investigate the best material for producing built-in defects,

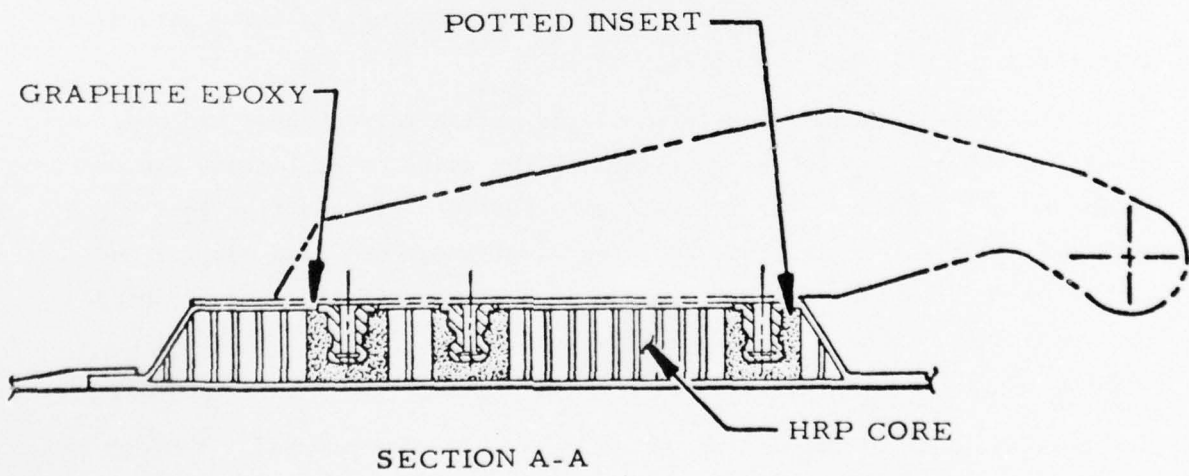
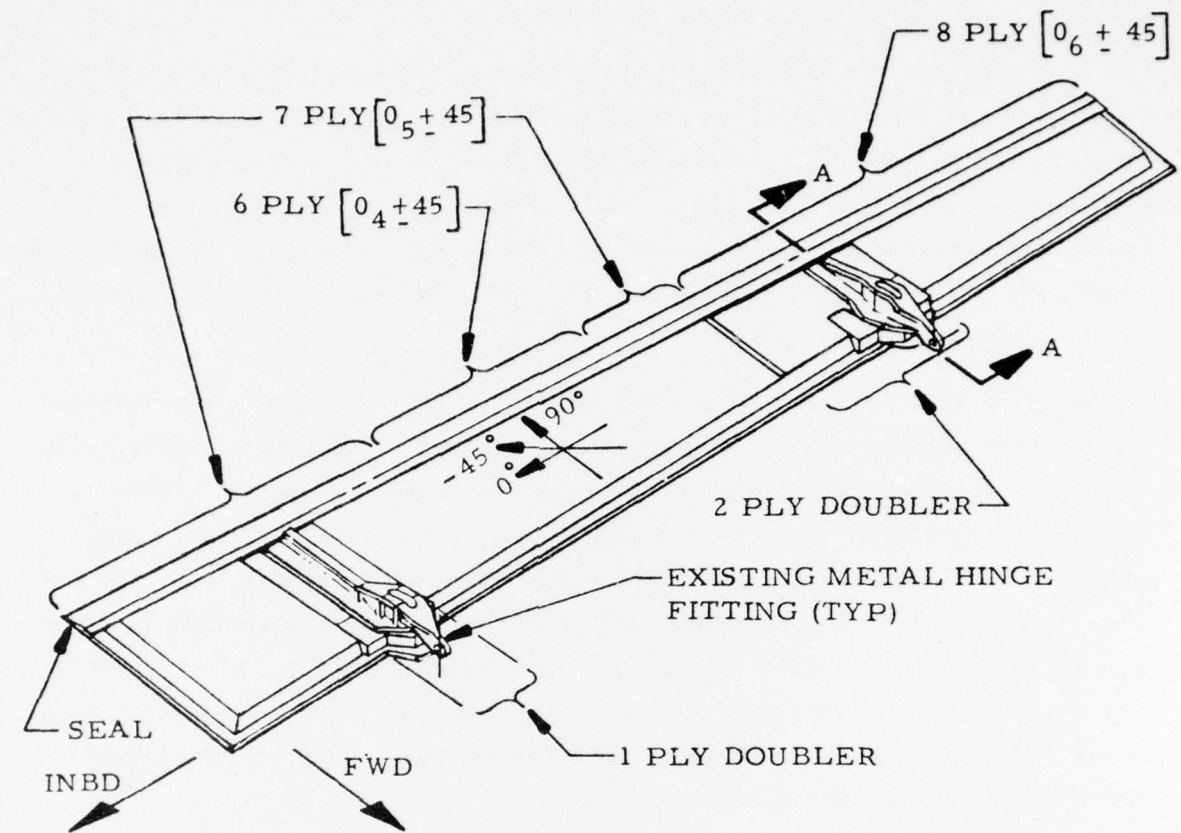

FIGURE 1 COMPOSITE SPOILER ASSEMBLY

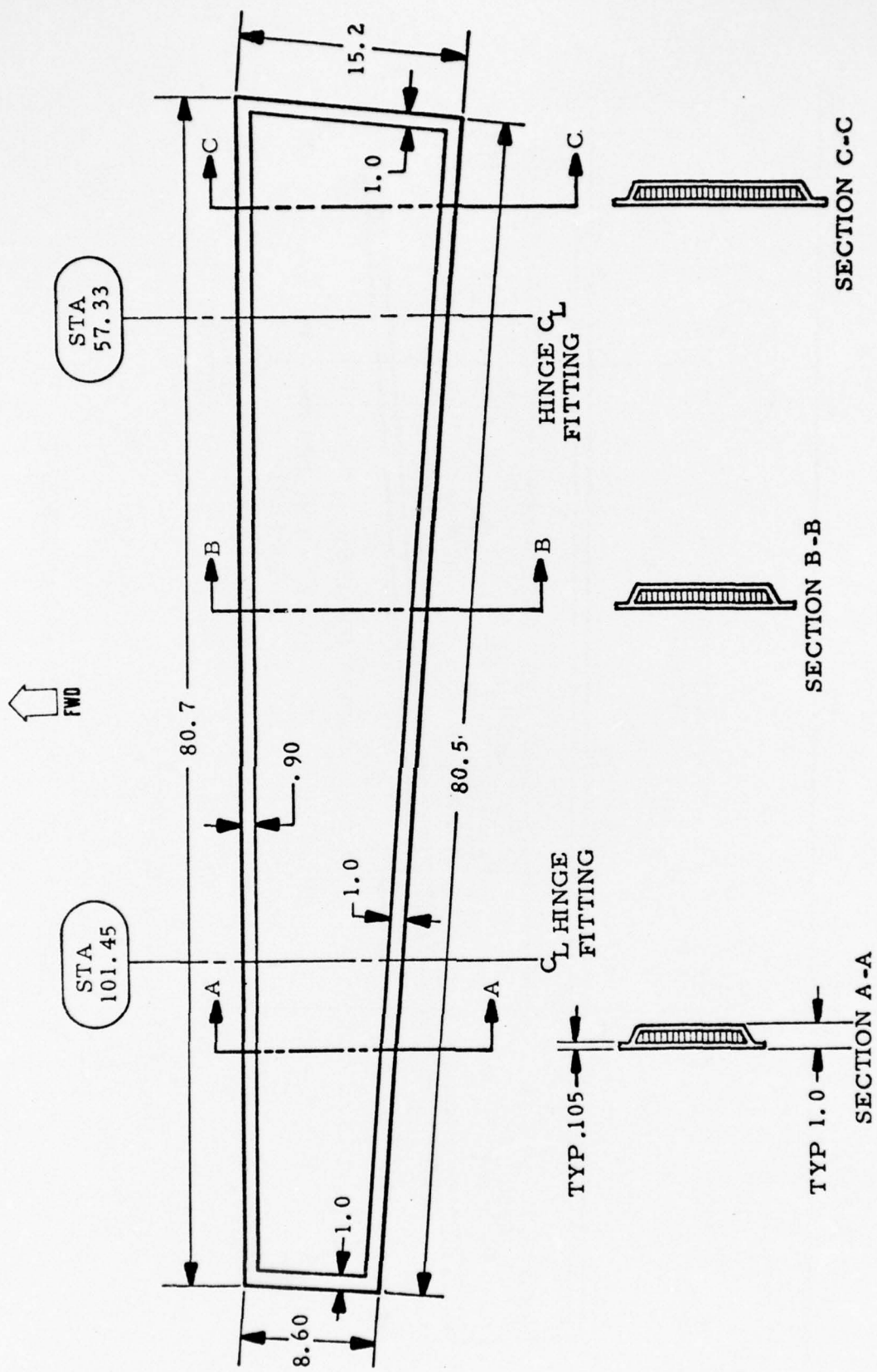
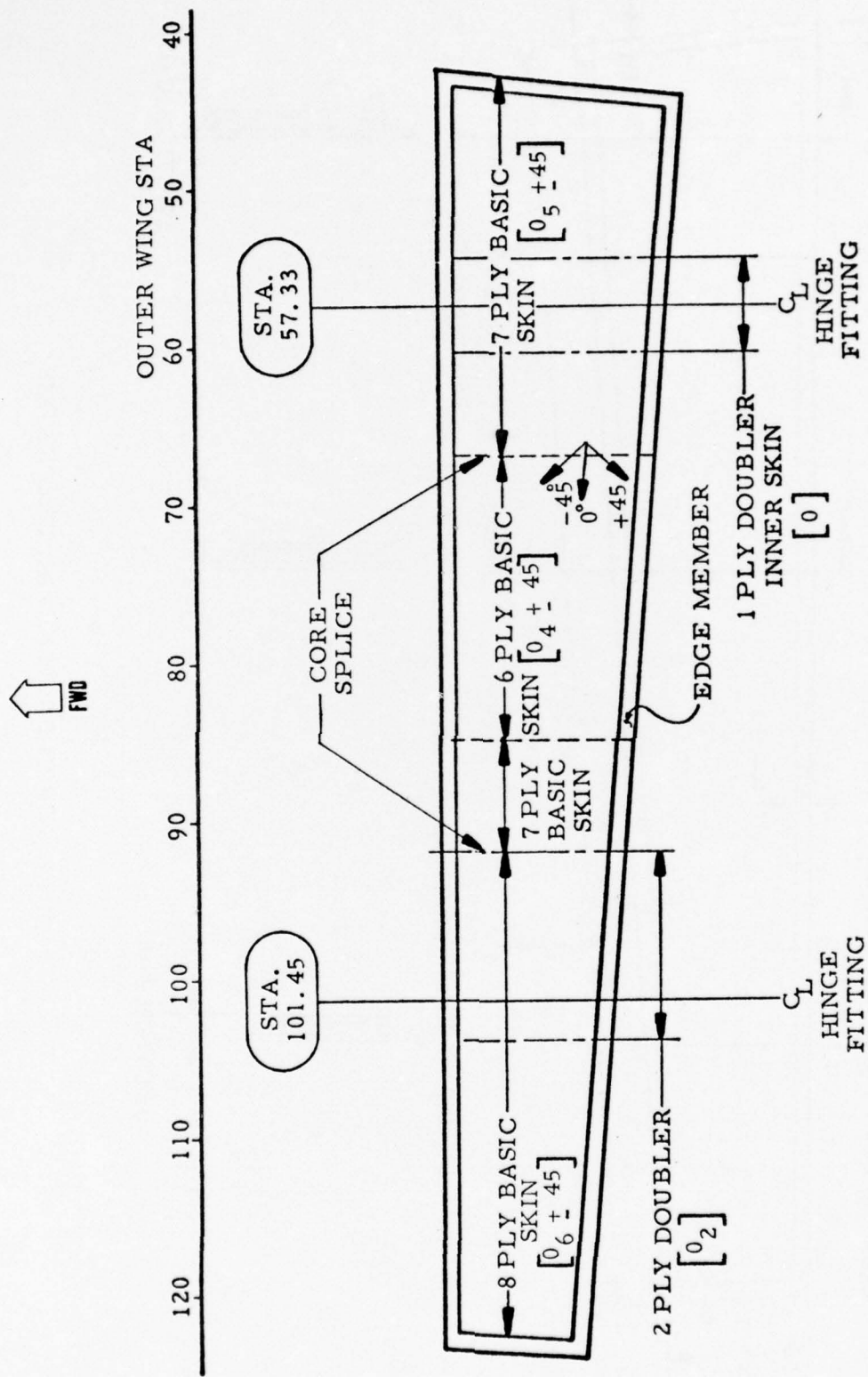

FIGURE 2 SPOILER GENERAL DIMENSIONS



CORE DENSITY IS 5.5#/FT³

FIGURE 3 CORE AND SKIN ARRANGEMENT

the minimum detectable defect size, the influence of varying the number of skin plies, the influence on attenuation properties of the amount of resin in honeycomb cells, and the influence on attenuation and physical properties of the amount of bleeder material used. The final standards were designed utilizing the information gained from the preliminary reference panels. These standards were fabricated in triplicate with two panels to be furnished to the Navy for field use and one panel to be retained by VSD for use in future production inspection. All reference panels were characterized by radiography, ultrasonic through transmission (immersion and contact) and ultrasonic pulse-echo methods. Procedures for field inspection using contact ultrasonic through transmission were developed and complete technique data sheets are included as Appendix A.

SECTION 2
REFERENCE STANDARD PANEL DEVELOPMENT

Ten experimental specimens were fabricated to provide the basis for the design and configuration of the final standard panel. The basic materials and processes used were the same as those used in the spoiler development program. These specimens were designated Quality Control Defect Specimens (QCDS) and were used both in defining fabrication techniques and inspection procedures. At the start of work all areas of the spoiler which have different cross section geometry were defined as zones. The lower spoiler has eight distinct zones of construction as required by either functional or structural constraints. Figure 4 defines these structural zones. One requirement of the specimen development work is the determination of how many different standards were required to satisfactorily inspect each of the defined spoiler zones.

Specimen QCDS-2 was a honeycomb panel 7.62 inches by 8.69 inches, with 8 ply faces representing the average skin thickness encountered in the spoiler. This panel was used in evaluating the various materials available to simulate bond line or interlaminar defects. Five types of defect materials were placed in the adhesive bond line both above and below the core. Two types of chemical filter materials were used. The first was a type "E" glass filter, Gelman Instrument Co.; the second was a teflon Millipore filter. These materials were encased in mylar tape or RTV 140. RTV 11 was used as the fifth material. Details of QCDS-2 are shown in Figure 5. NDI results of the completed specimen indicated the best of the candidate materials was the glass filter material sealed in mylar tape.

Figures 6, 7, and 8 show reproductions of the C-scan recordings at increasing gain settings obtained with ultrasonic through transmission with the panel immersed in water. The gain settings for the Sperry UM 721 unit used for immersed through transmission are shown with a notation such as X1+3. The X1 indicates the machine setting of the Coarse gain adjustment, while the +3 indicates the Fine gain setting. The larger the gain setting, the greater the amplification of the received ultrasonic signal. Other machine settings given include the frequency of pulse tuning (Tuned), the pulse length (PL), and the reject setting. The types of transducers used for transmitting (T) and receiving (R) are also indicated. The glass fiber filter sealed in mylar tape (#4) was selected as the one of the five materials used which best represented a lack of bond between skin and core.

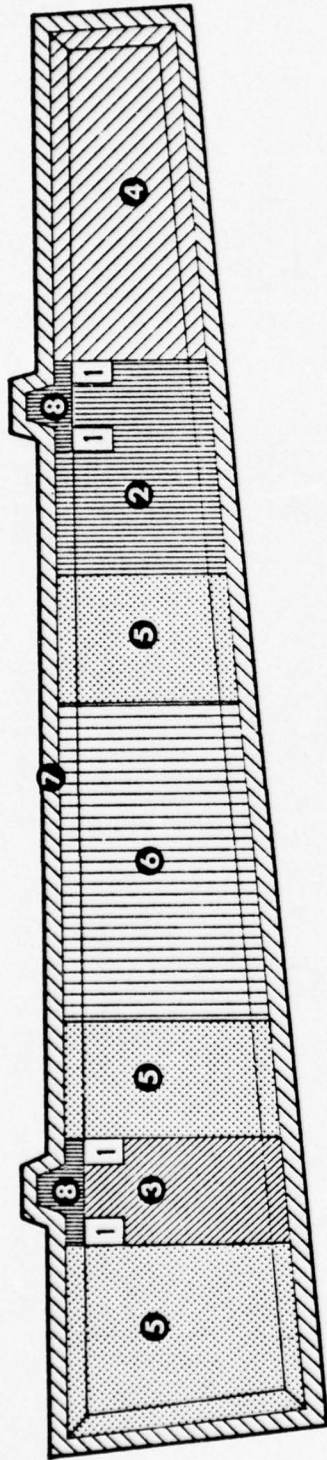

← INBD

LOWER SPOILER ZONE CHART

SPOILER ZONE	DESCRIPTION
Zone 1	Sandwich, lower skin, upper skin, doubler & 4 ply tab skin
Zone 2	Sand., 8 ply lower skin, 8 ply upper skin, 2 ply doubler on upper skin
Zone 3	Sand., 7 ply lower skin, 7 ply upper skin, 1 ply doubler on upper skin
Zone 4	Sandwich, 8 ply lower skin, 8 ply upper skin
Zone 5	Sandwich, 7 ply lower skin, 7 ply upper skin
Zone 6	Sandwich, 6 ply lower skin, 6 ply upper skin
Zone 7	Solid laminate edge band (21 plies)
Zone 8	Tab stiffener over edge band at hinges

FIGURE 4: GRAPHITE / EPOXY STRUCTURAL ZONE DEFINITION

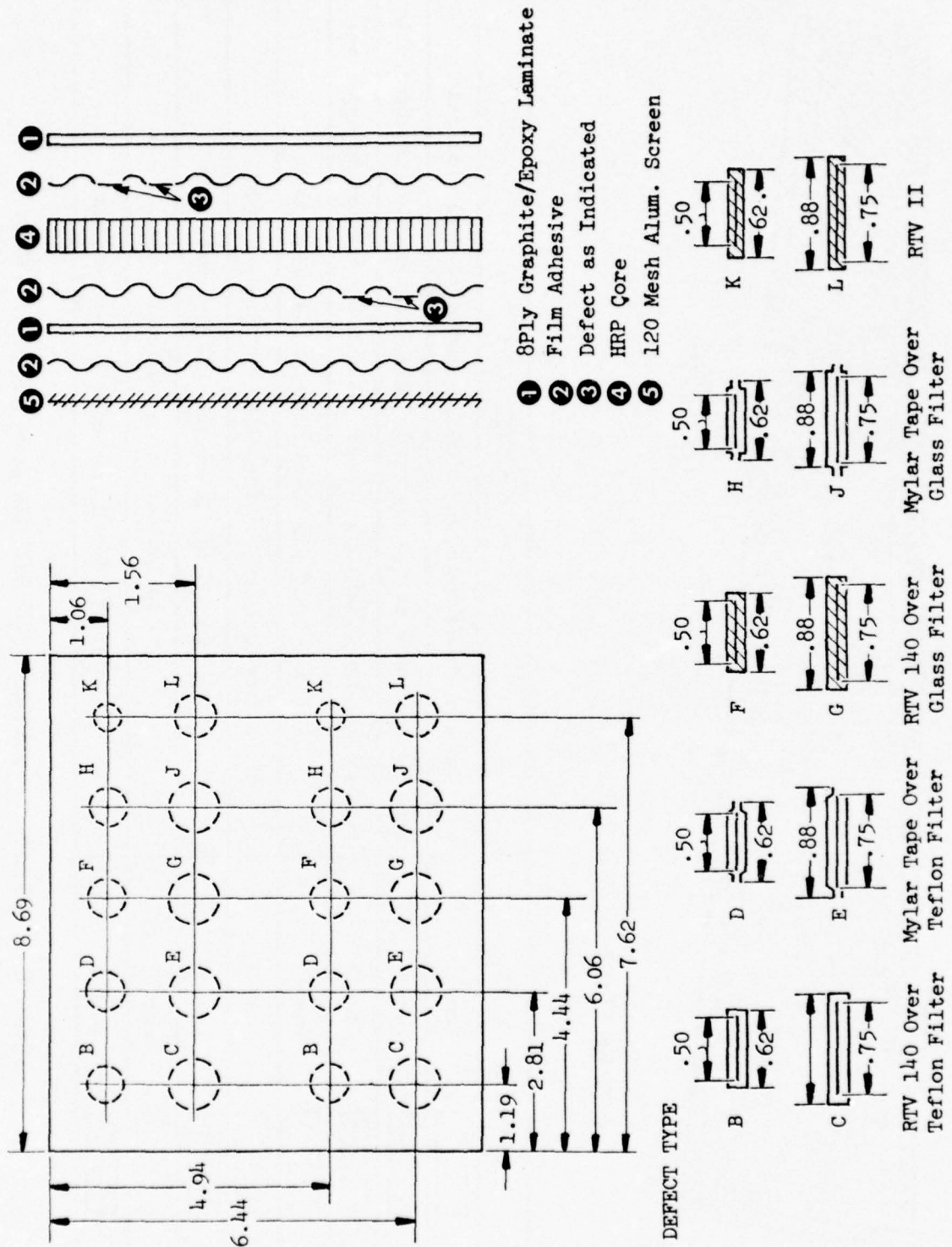
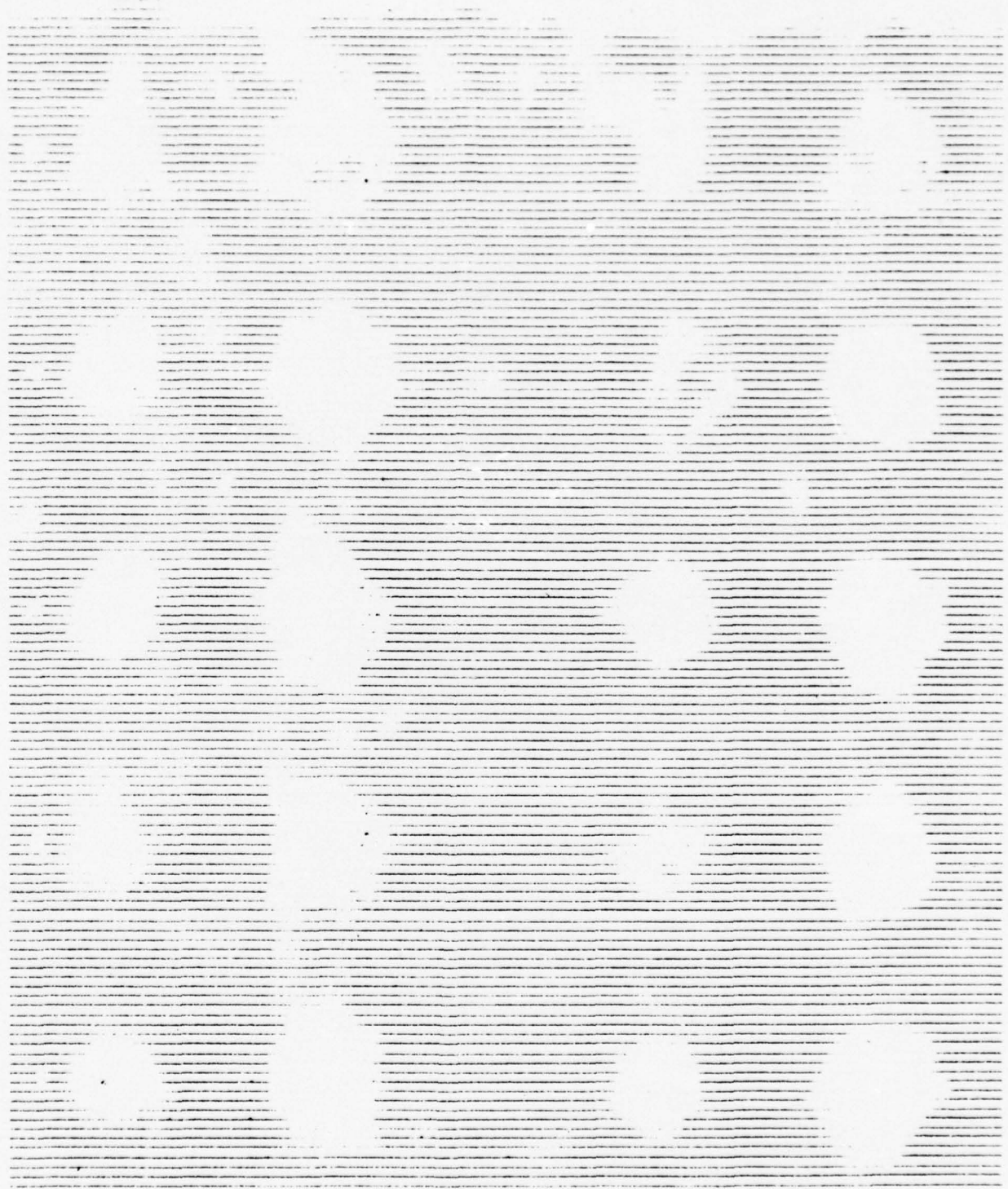
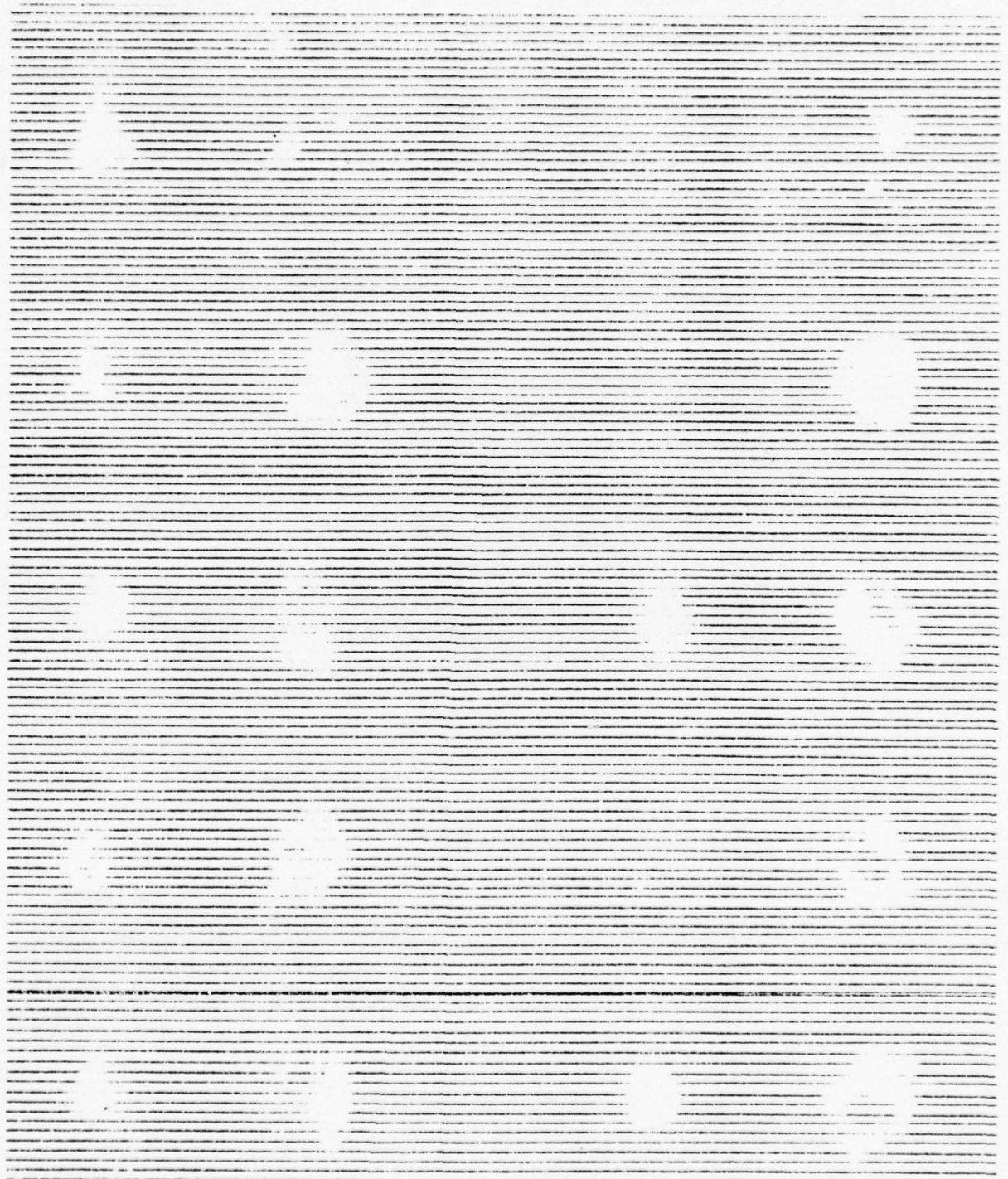

FIGURE 5: QCDS -2 SPECIMEN DETAIL



X1+3 TUNED 1 MHz PL 50%
T&R 1/2' 1MHz Foc REJECT 0

FIGURE 6: QCDS-2 ULTRASONIC RECORD @ X1+3



X1+6 TUNED 1 MHz PL 50%
T&R 1/2" 1MHz Foc REJECT 0

FIGURE 7: QCDS-2 ULTRASONIC RECORD @ X1+6

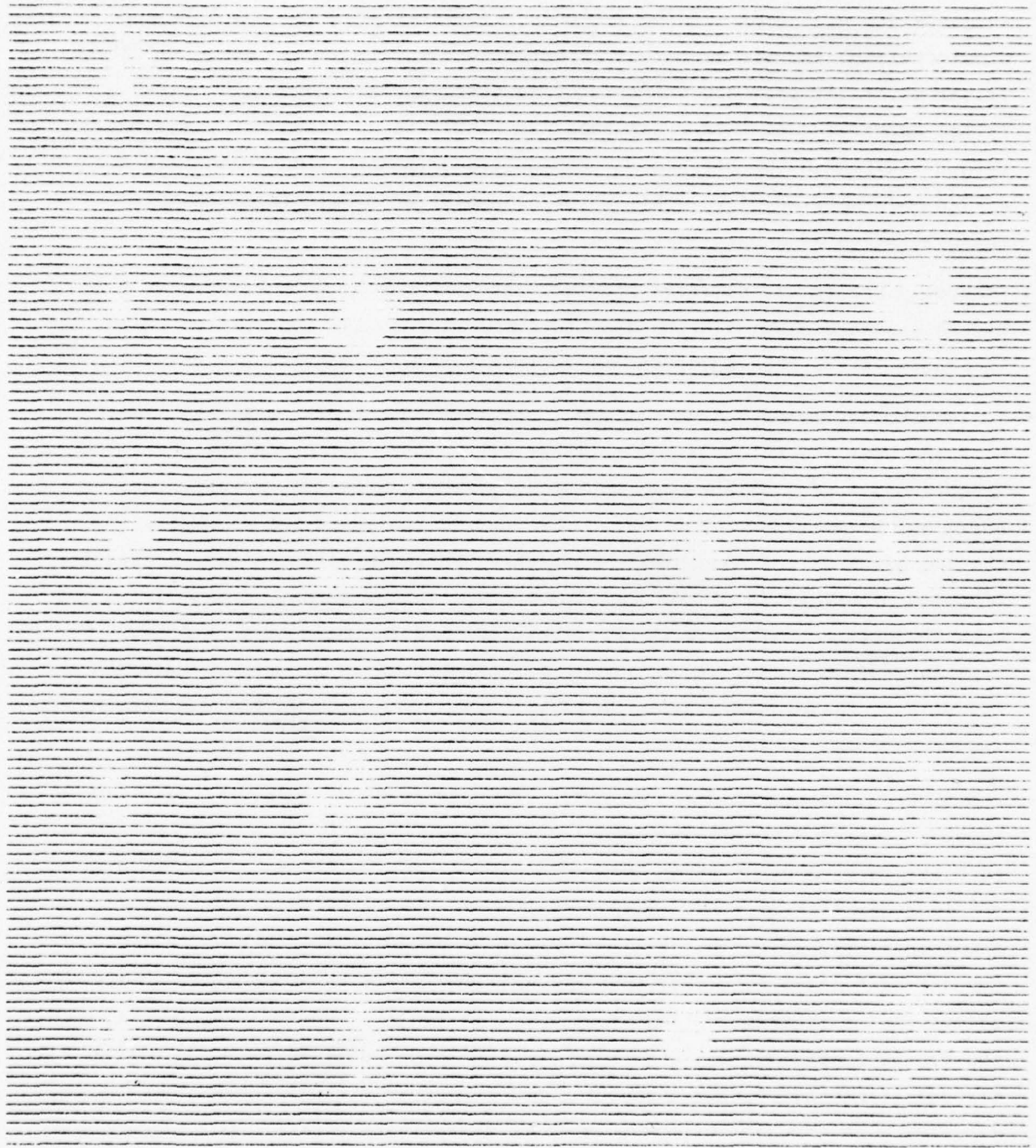

X1+8 TUNED 1 MHz PL 50%
T&R 1/2" 1MHz Foc REJECT 0

FIGURE 8: QCDS-2 ULTRASONIC RECORD @ X1+8

One of the objectives of the standards development program was to adequately simulate defects such as skin ply delaminations or skin to core debonds. Both of these defects are air gaps which have been left in the material by the separation of layers. The inclusion of filter material which is approximately 80-85% air space was selected to simulate an air gap. Different filter materials provided differing responses to ultrasound. The glass filter material sealed in mylar tape was highly sound attenuating and remained visible in the ultrasonic through transmission C-scan recording at a high gain setting, i.e., this material exhibited a gain level response representative of a naturally occurring defect.

Figures 9 and 10 are positive prints of radiographs of QCDS-2. Figure 9 was an exposure made with the beam perpendicular to the top surface while in Figure 10 the beam was parallel to this surface.

Pulse-echo and through transmission inspection techniques were investigated with the Navy's Sonic unit. A satisfactory pulse-echo method was not found since a meaningful difference in display between normal and defect areas could not be obtained. The difficulty in distinguishing the responses in the two areas is not encountered when through transmission is used. Figure 11 shows a photograph of the instrument display in a through transmission mode transmitting with a 2.25 MHz transducer and receiving with a 1 MHz transducer in a normal area. Figure 12 shows the display when the transducers are placed over a built-in defect. The responses in the two areas are readily recognized.

The QCDS-3 specimen is a 21 ply solid laminate as shown in Figure 13. Two types of defect material were used; one set was glass fiber filters sealed in mylar tape, and the other set was teflon tape. Defect sizes ranged from 3/8 inch diameter to 1 inch diameter, and all were located in Ply 13 as shown in Figure 13. The results of these embedded materials again show the sealed filters to give a gainlevel response more representative of a defect in the material. Figures 14, 15, 16, and 17 show reproductions of the C-scan recordings at increasing gain settings obtained with ultrasonic through transmission with the panel immersed in water. The defects constructed with the teflon tape show two disadvantages: First they disappear from the recording at a lower gain setting (Fig. 16) than the glass in mylar defects, two of which still show up at the maximum gain setting (Fig. 17).

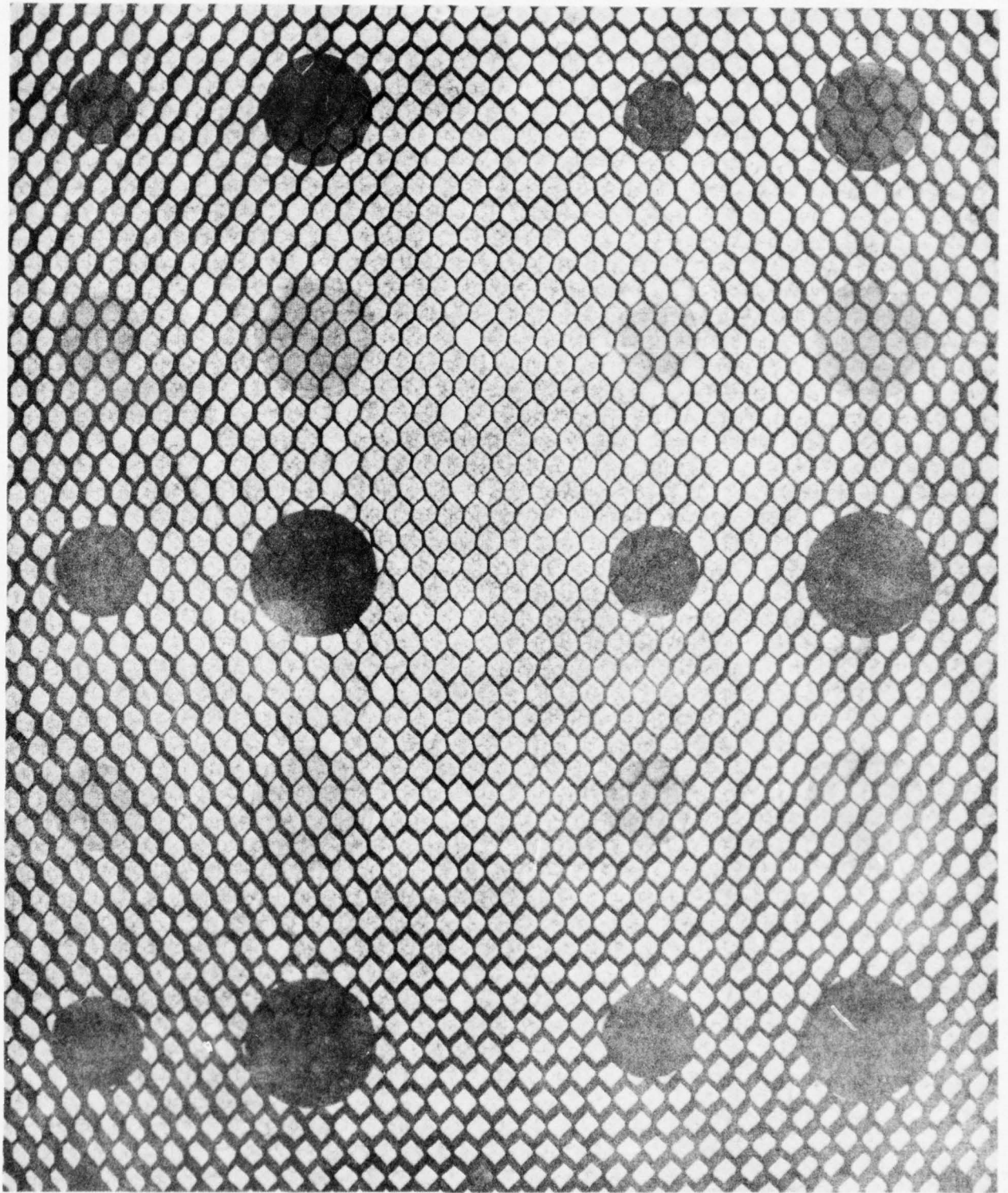

FIGURE 9: RADIOGRAPH OF QCDS-2 SPECIMEN (PLAN VIEW)

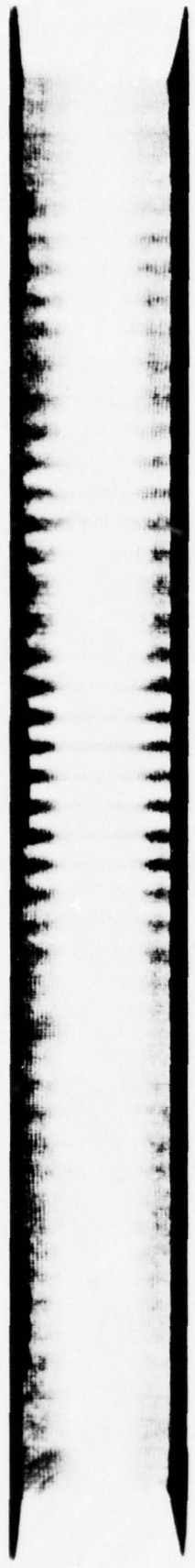

FIGURE 10: RADIOGRAPH OF QCDS-2 SPECIMEN (EDGE VIEW)

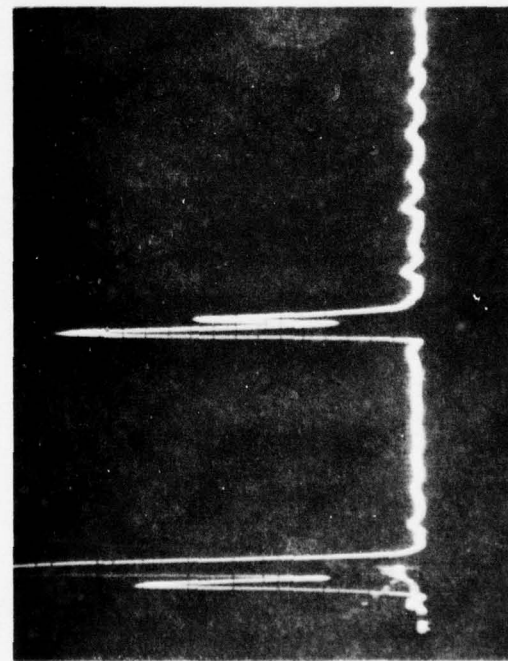

FIGURE 11: CRT SCOPE DISPLAY OF QCDS-2 SPECIMEN IN NORMAL AREA BY THRU TRANSMISSION

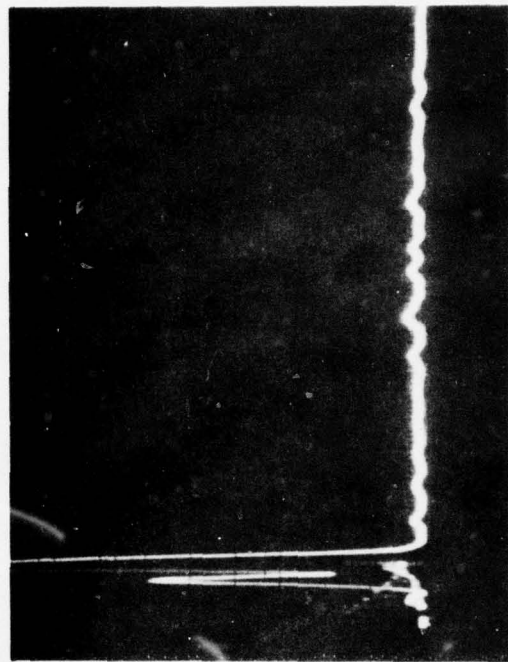
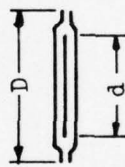
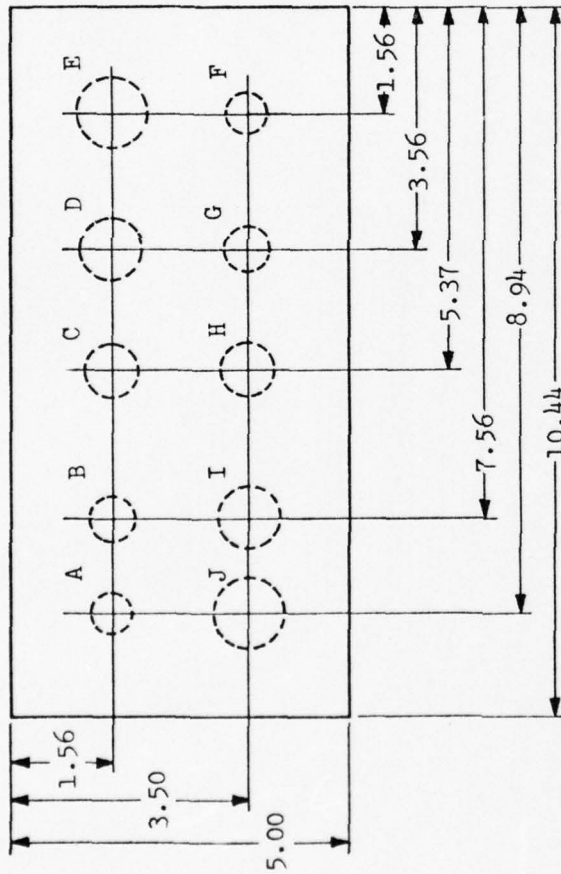

FIGURE 12: CRT SCOPE DISPLAY OF QCDS-2 SPECIMEN IN DEFECT AREA BY THRU TRANSMISSION



DEFECT TYPE A - E

D material is mylar tape
d material is glass filter

DEFECT	D dim.	d dim.
A	.50	.37
B	.62	.50
C	.75	.62
D	1.00	.88
E	1.12	1.00

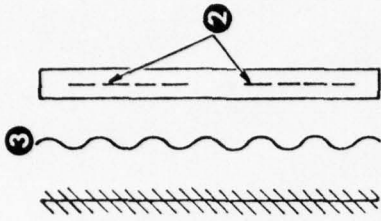

DEFECT TYPE F - J

d material is teflon tape

- 1 21 ply graphite/epoxy laminate
- 2 defects in ply 13
- 3 film adhesive (M1113)
- 4 120 mesh alum. screen

DEFECT	d dim.
F	.37
G	.50
H	.62
I	.88
J	1.00

FIGURE 13: QCDS-3 SPECIMEN DETAIL

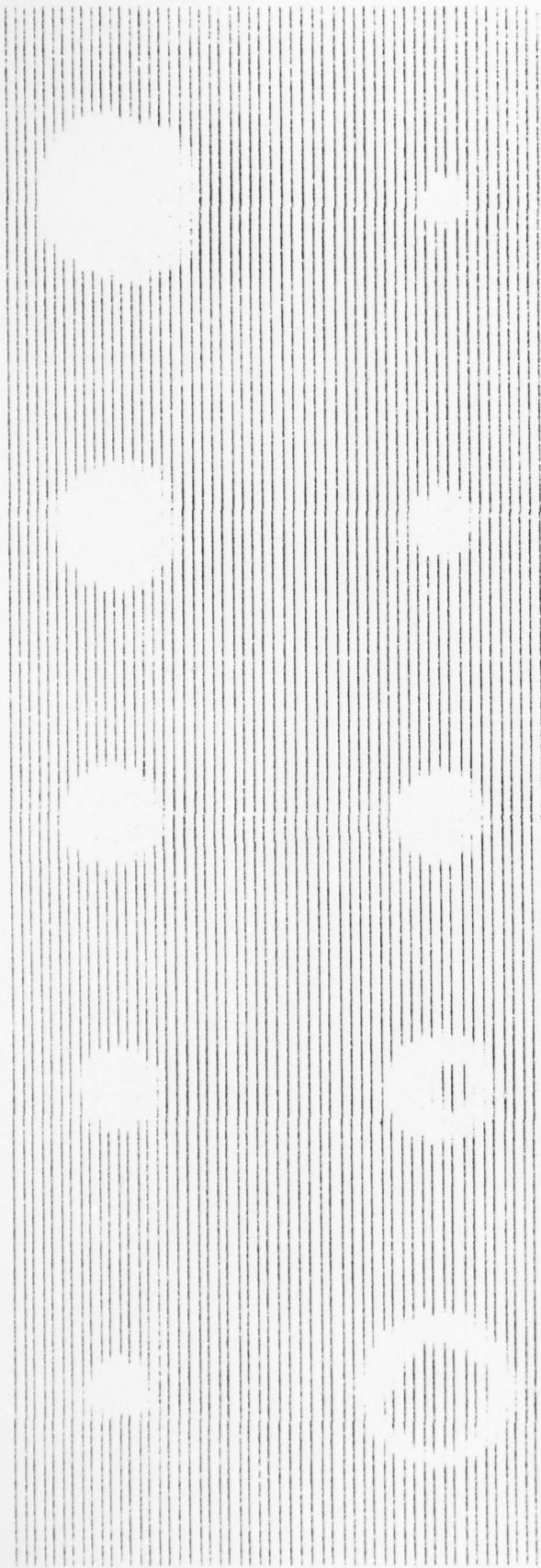

FIGURE 14: QCDS-3 ULTRASONIC RECORD @ X0.1 + 2

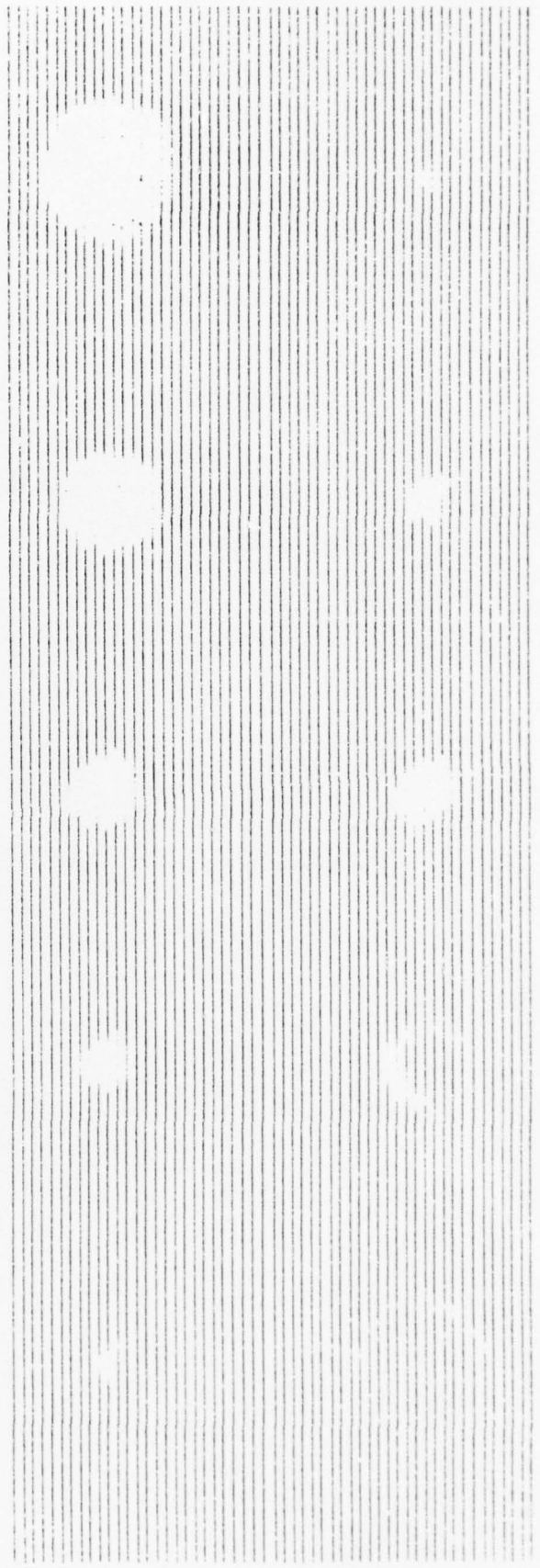

FIGURE 15: QCDS-3 ULTRASONIC RECORD @ X1 + 3

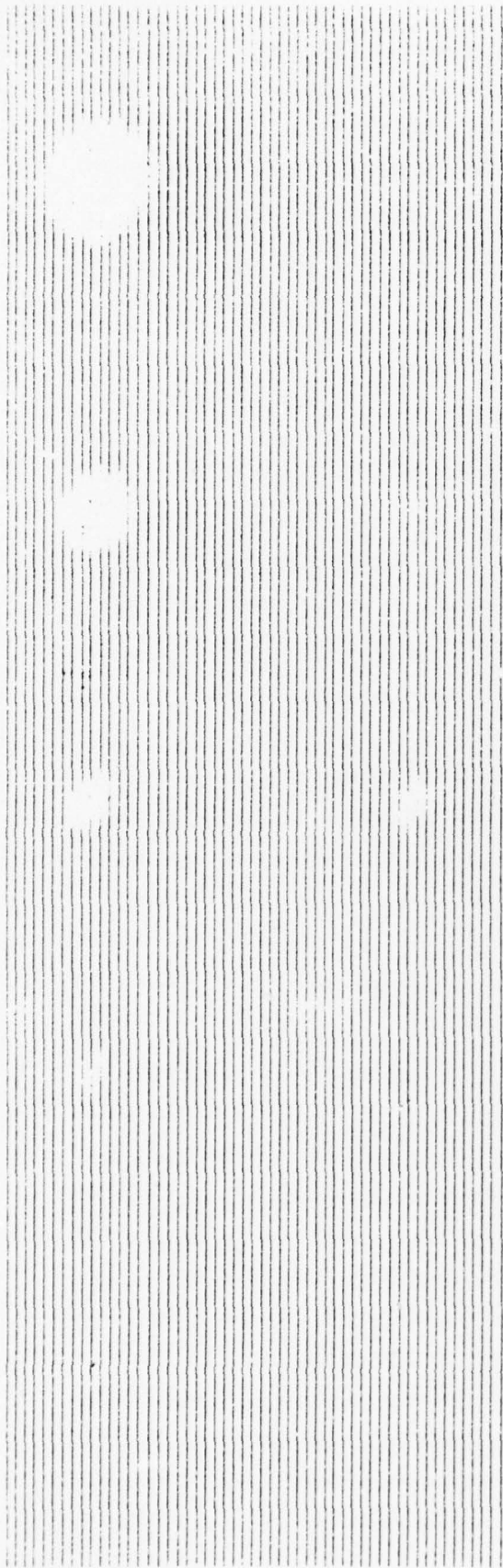

FIGURE 16: QCDS-3 ULTRASONIC RECORD @ X10 + 0.4

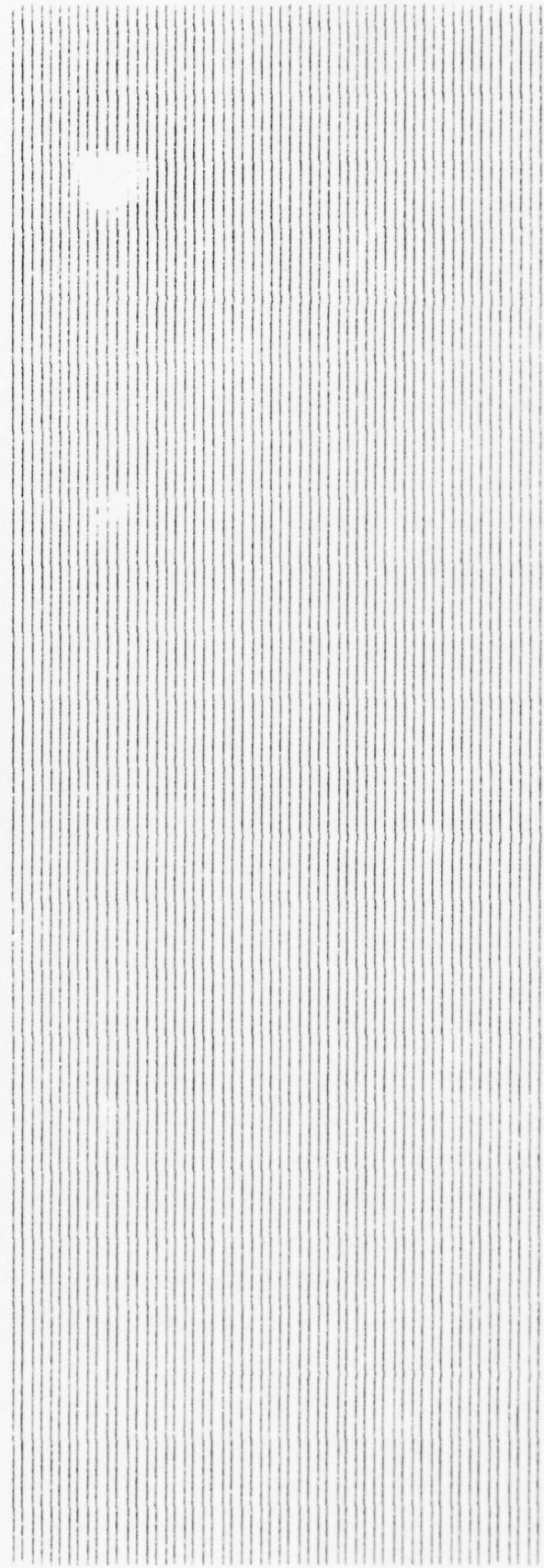

FIGURE 17: QCDS-3 ULTRASONIC RECORD @ X10 + MAX

Second, the two teflon defects of the largest diameter disappear before the smaller defects (Fig. 15). The inconsistency of results with the teflon material and the desirability of results at high gain settings led to the choice of glass fiber filter sealed in mylar tape as the defect material to be used in following preliminary specimens and in the final standards.

Figure 18 is a positive print made from the radiograph of the solid laminate reference panels QCDS-3 and QCDS-6 through 10. The radiograph shows the combination of the glass filter with the mylar tape quite well.

Pulse-echo and through transmission inspection techniques were investigated for the solid laminate using the Navy ultrasonic unit. Figure 19 shows the instrument display when using a 2.25 MHz transducer in the pulse-echo mode in a normal section of laminate. The shorter return time for the signal over a built-in defect is shown in Figure 20. Since thickness variations in a laminate will also produce a time shift in the display, much caution should be used in drawing conclusions from pulse-echo time shifts.

Figures 21 and 22 show the instrument display obtained using a through transmission method on the same normal and defect areas. The transducers used were a 0.5" diameter 2.25 MHz for transmitting and 1.0 MHz for receiving. The simple contrast of large received signals in Figure 21 and no received signal in Figure 22 is more obvious than the time shift seen with the pulse-echo method. Thickness variations in the laminate would only cause small amplitude changes in the peaks seen in Figure 21. It should also be noted that depth of a defect from the surface is not obtainable with "C" scan thru transmission ultrasonic inspection.

Two honeycomb sandwich reference panels were fabricated representing the minimum and maximum numbers of skin plies present in the spoiler. QCDS-4 had six ply upper and lower skins, while QCDS-5 had eight ply lower and ten ply upper skins. Each specimen contained 6 defects fabricated from glass filters enclosed in mylar tape; construction details are shown in Figure 23. The information furnished by these two panels along with the examination of the ply drop-off area in one of the static test spoilers provided a basis for deciding whether or not the final reference standard should include a separate reference area for each ply thickness in the spoiler. Three ultrasonic C-scan recordings of QCDS-4 and 5 using immersion through transmission are shown in Figures 24, 25, and 26. Both these panels were more highly attenuating than QCDS-2 (compare gain settings Figures 6 and 24) and QCDS-5

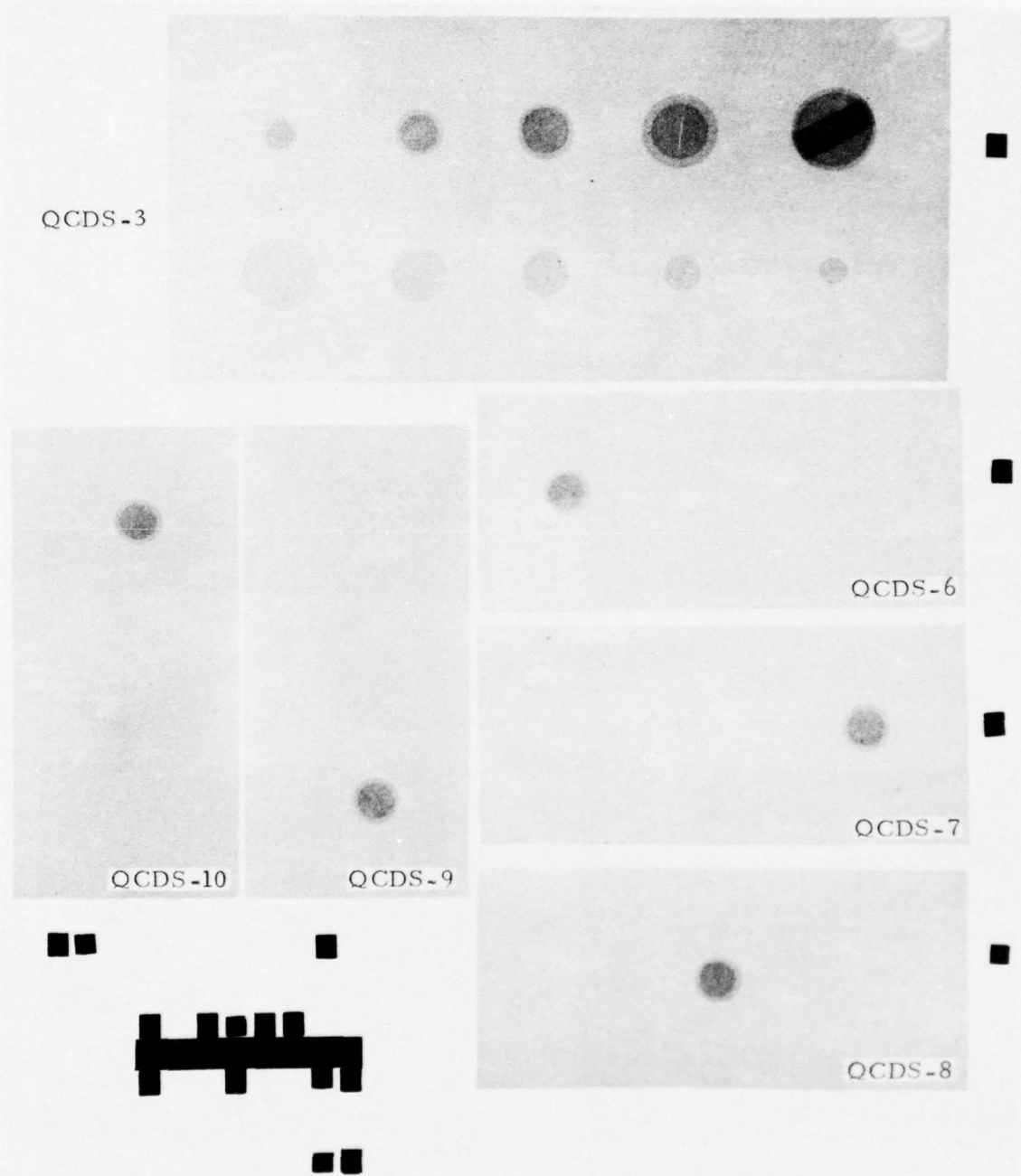

FIGURE 18: RADIOGRAPH OF DEFECT SPECIMENS

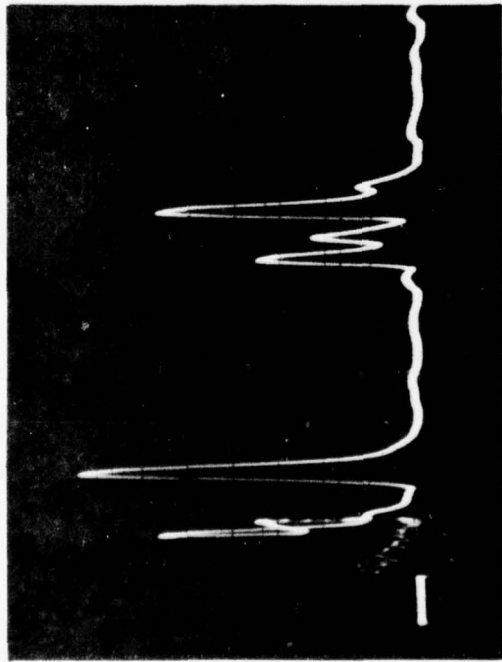

FIGURE 19: CRT SCOPE DISPLAY FOR PULSE ECHO ON QCDS-3 NORMAL AREA

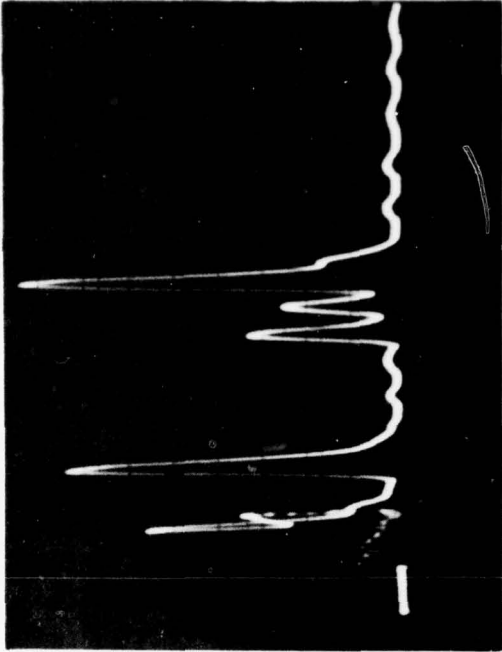

FIGURE 20: CRT SCOPE DISPLAY FOR PULSE ECHO ON QCDS-3 IN DEFECT AREA

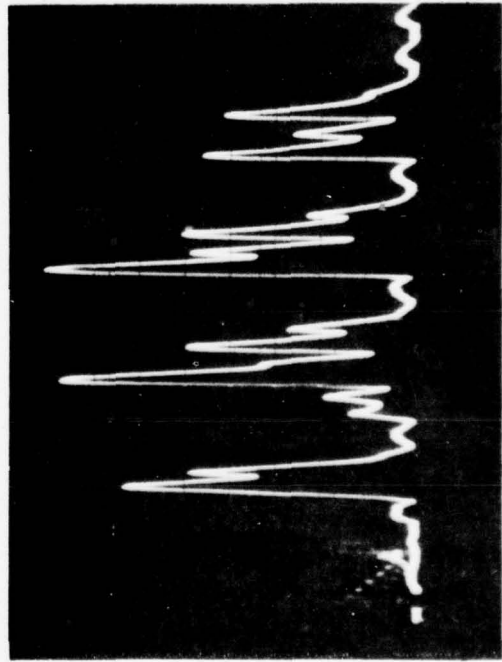

FIGURE 21: CRT SCOPE DISPLAY FOR QCDS-3 WITH THRU TRANSMISSION IN NORMAL AREA

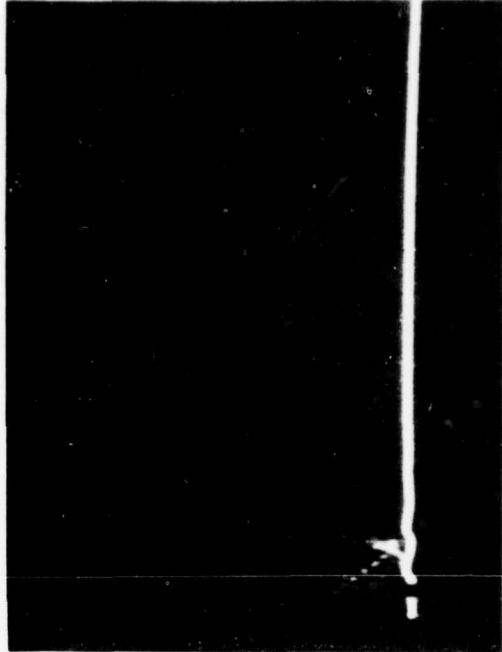
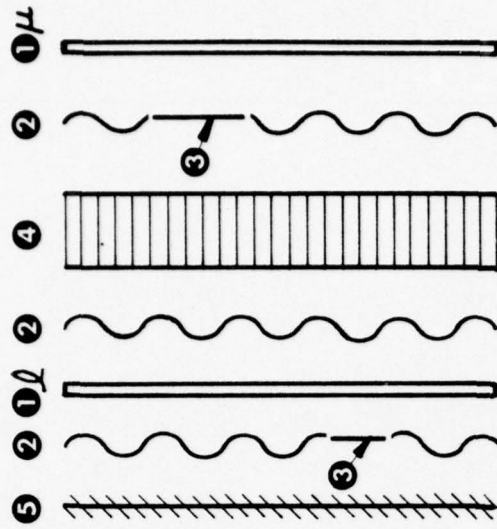
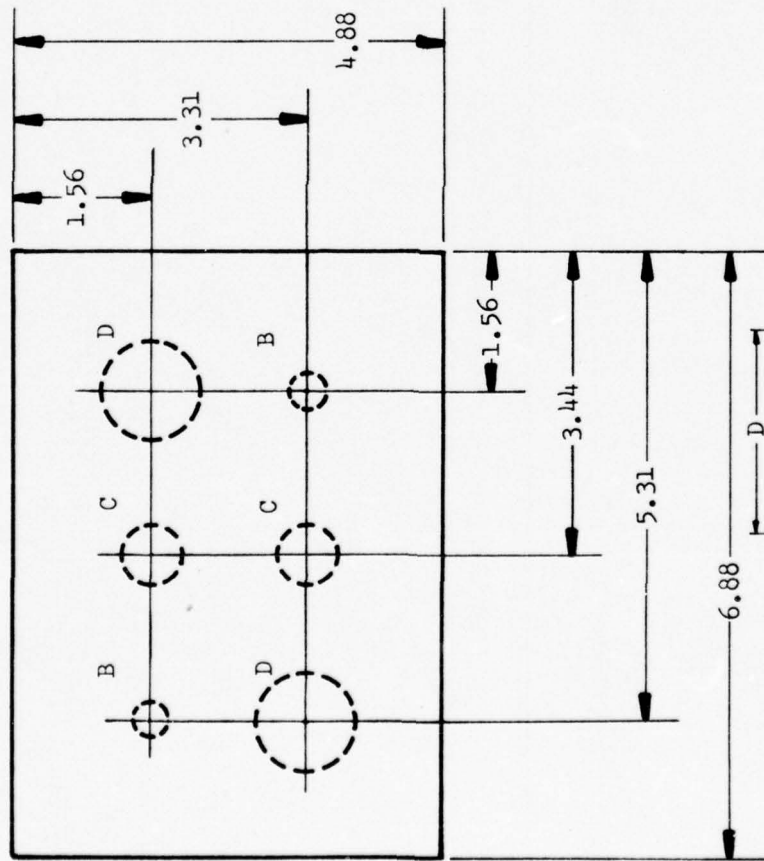

FIGURE 22: CRT SCOPE DISPLAY FOR QCDS-3 WITH THRU TRANSMISSION IN DEFECT AREA



- 1.0 GRAPHITE / EPOXY LAMINATE
(6 PLY QCDS-4, 10 PLY QCDS-5)
- 1/4 GRAPHITE / EPOXY LAMINATE
(6 PLY QCDS-4, 8 PLY QCDS-5)
- 2 FILM ADHESIVE (MILL3)
- 3 DEFECT MATERIAL
- 4 HRP CORE
- 5 120 MESH ALUMINUM SCREEN



DEFECT TYPE

GLASS FILTER IN MYLAR TAPE

DEFECT	D dim	d dim
B	.37	.25
C	.67	.50
D	1.12	1.00

FIGURE 23: QCDS-4 AND QCDS-5 SPECIMEN DETAIL

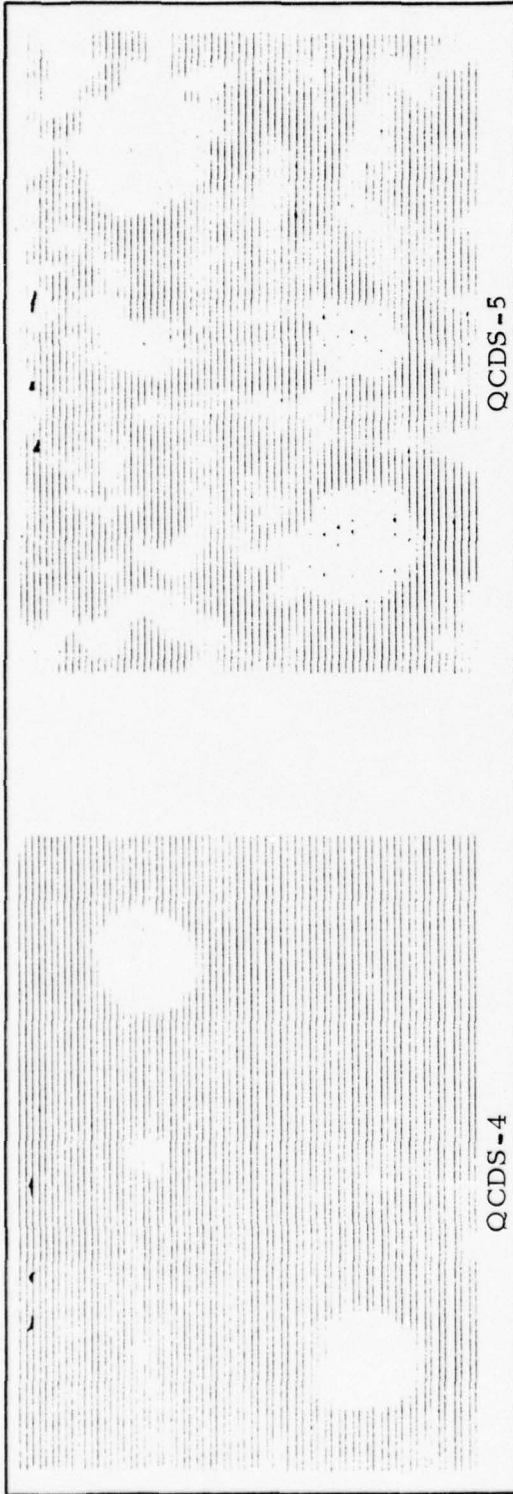

FIGURE 24: QCDS -4 AND QCDS -5 ULTRASONIC RECORD AT X10+1

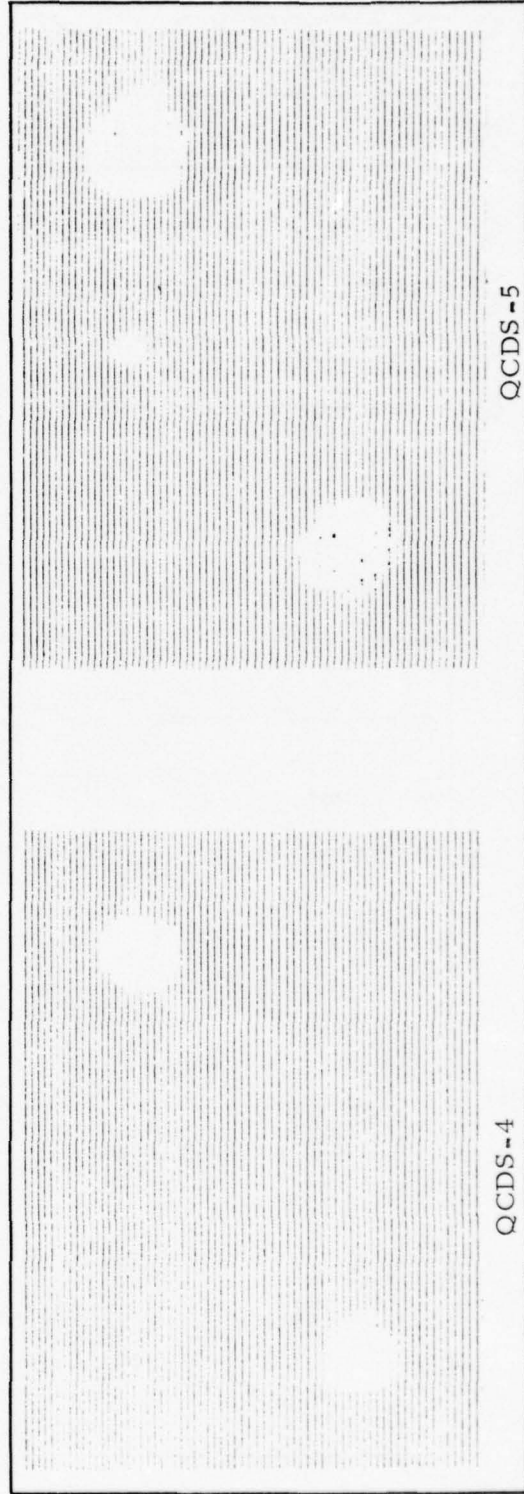
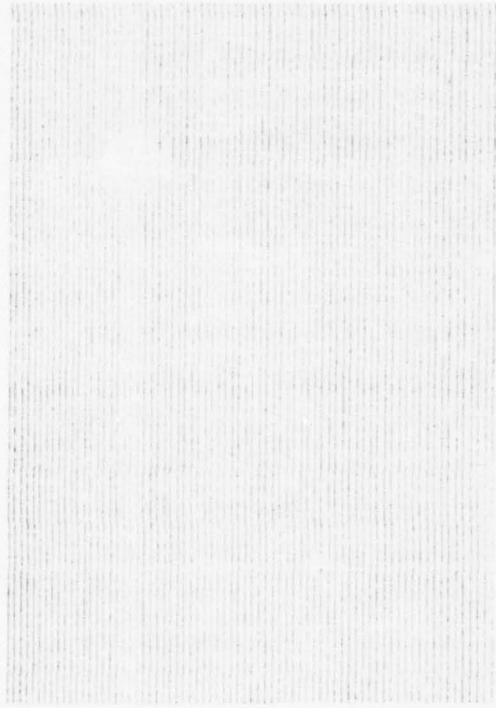
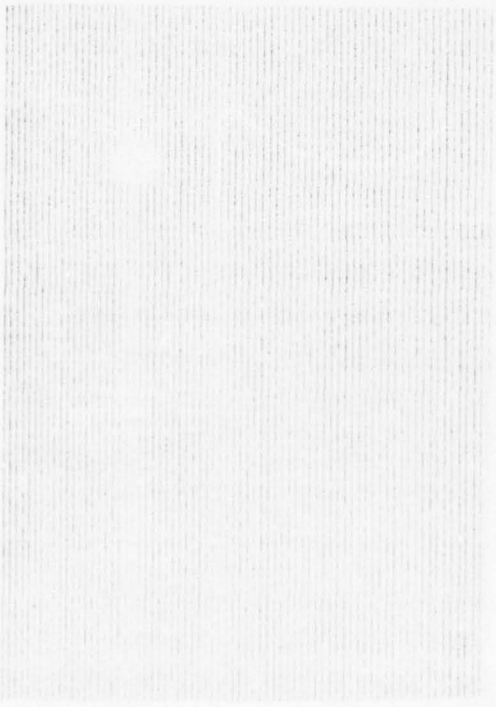

FIGURE 25: QCDS -4 AND QCDS -5 ULTRASONIC RECORD AT X10+ 2



QCDS -4



QCDS -5

FIGURE 26: QCDS -4 AND QCDS -5 ULTRASONIC RECORD AT X10+6

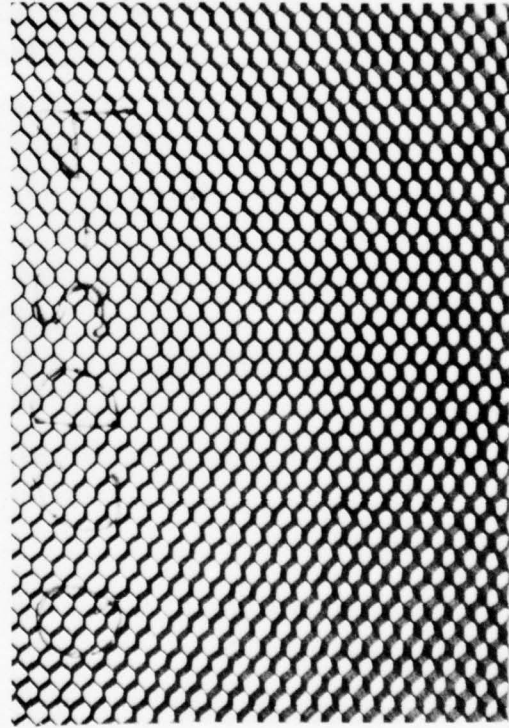

QCDS -4

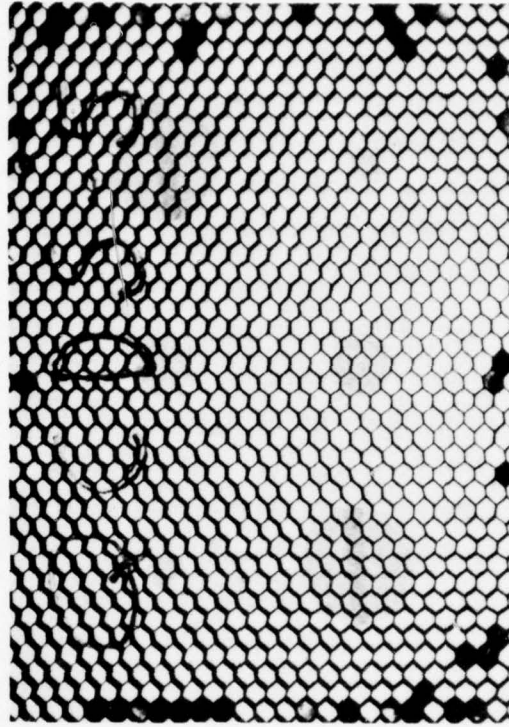

QCDS -5

FIGURE 27: RADIOGRAPH OF QCDS -4 AND QCDS -5 SPECIMENS (PLAN VIEW)

was more highly attenuating than QCDS-4. Figure 27, a positive print of the radiograph of the two panels, also shows more density in core cells. In Figure 28, positive prints of radiographs of these panels with the beam perpendicular to the core walls, shown an even greater contrast in densities within the panel. As reported in previous studies (2-42000/5QCR-5) the difference in sound attenuation level is due to differing amounts of resin accumulation in the core and has no relation to the number of skin plies in the test panels.

Static test article #2 was examined ultrasonically and radiographically in the section where skin plies drop from 10 ply to 6 ply. Figure 29 shows a reduced reproduction of the ultrasonic through transmission C-scan recordings of the spoiler. Numbers indicate the number of skin plies. No difference in attenuation level is noticed as the ply number changes. However, it will be noted that the core splice area and the beveled edge always show as attenuating areas because of the change in local densities. Figure 30 shows a positive print of the radiograph made of this area. Skin ply changes are only discernible as gradual density variation.

The final standards were designed with an average number of skin plies since the variation does not appear to significantly affect NDI results.

Five 21-ply solid laminate panels designated QCDS-6, -7, -8, -9 and -10 were fabricated to determine the effect of over or under bleeding resin from the advanced composite material on physical properties including thickness, fiber volume, ultrasonic and radiographic responses. Construction details of these specimens are shown in Figure 31. Each specimen contained one defect as indicated for reference in radiographic and ultrasonic evaluation. The number of bleeder plies used for each specimen and the effect on thickness and fiber volume percent is shown in Table I. Figure 32 presents a reduced reproduction of the ultrasonic thru transmission recordings for each of the five specimens and a radiograph for each is shown in Figure 18. Neither ultrasonics or radiography indicates a measurable difference in the panels evaluated.

A single specimen designated QCDS-11 was fabricated to represent the area of the outboard tab stiffener. The basic difference in construction is due to the addition of a precured skin and core stiffener area to the basic spoiler cross section. The section of the specimen which represents the spoiler

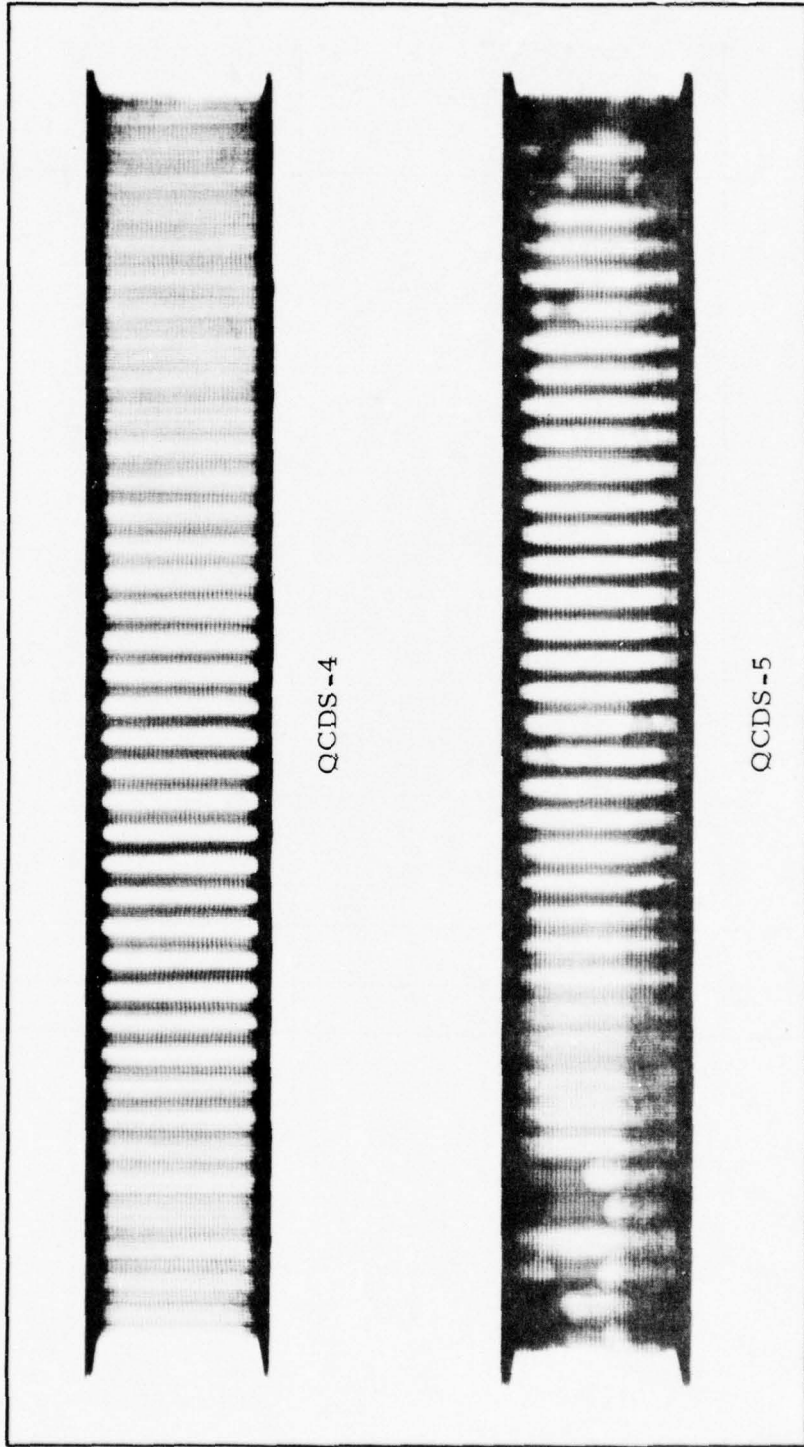

QCDS-4

QCDS-5

FIGURE 28: RADIOGRAPH OF QCDS-4 AND QCDS-5 SPECIMENS (EDGE VIEW)

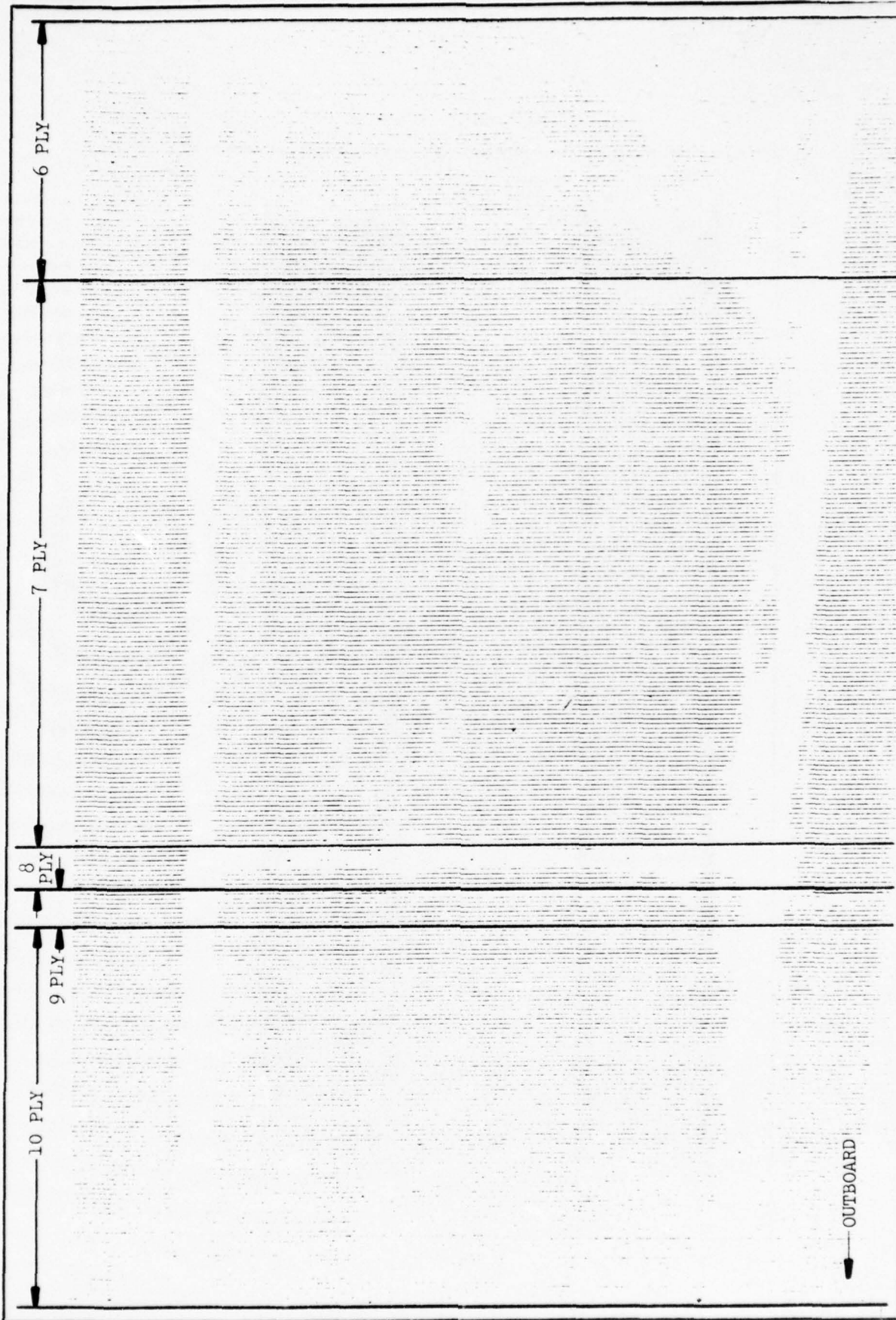
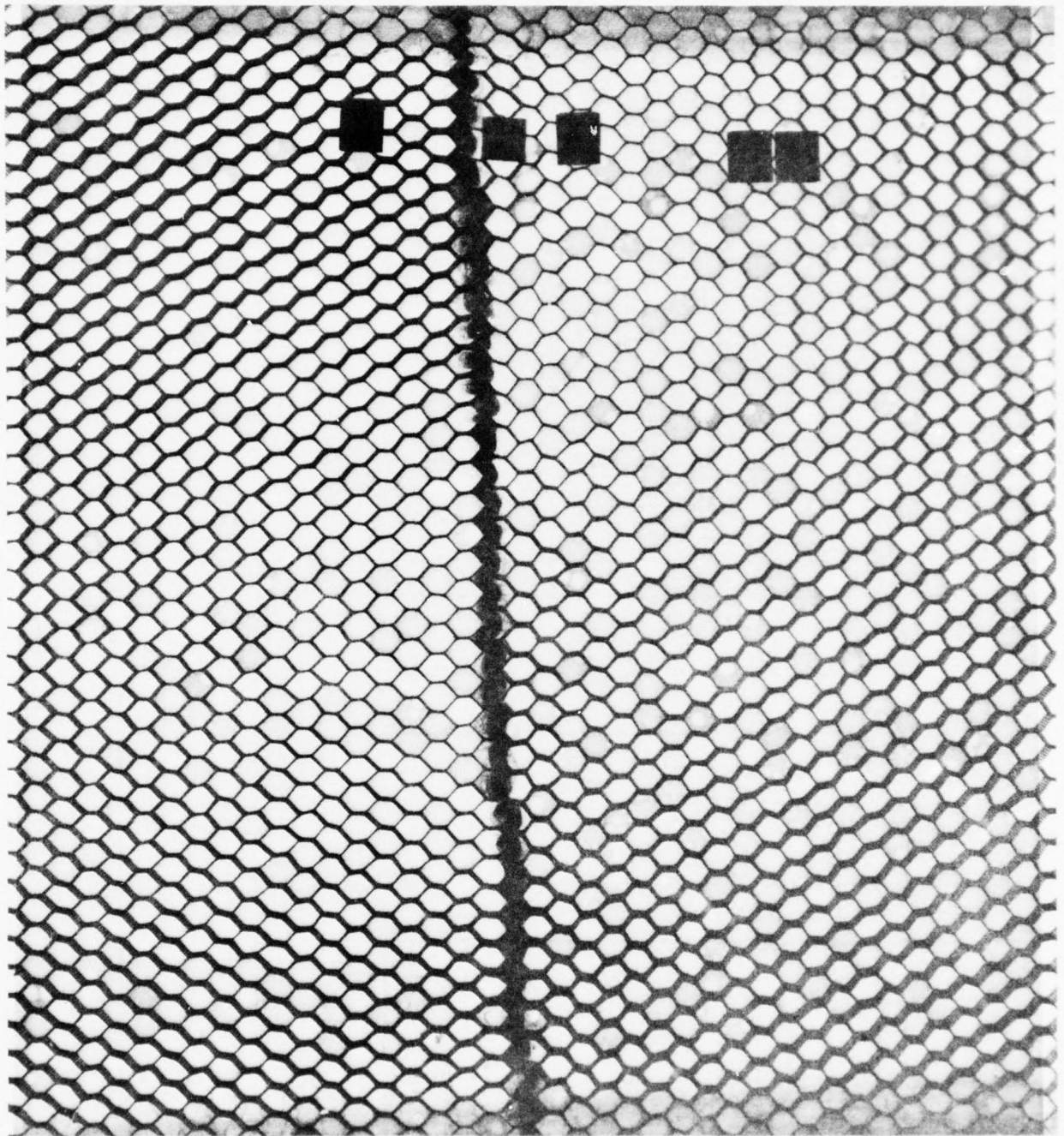
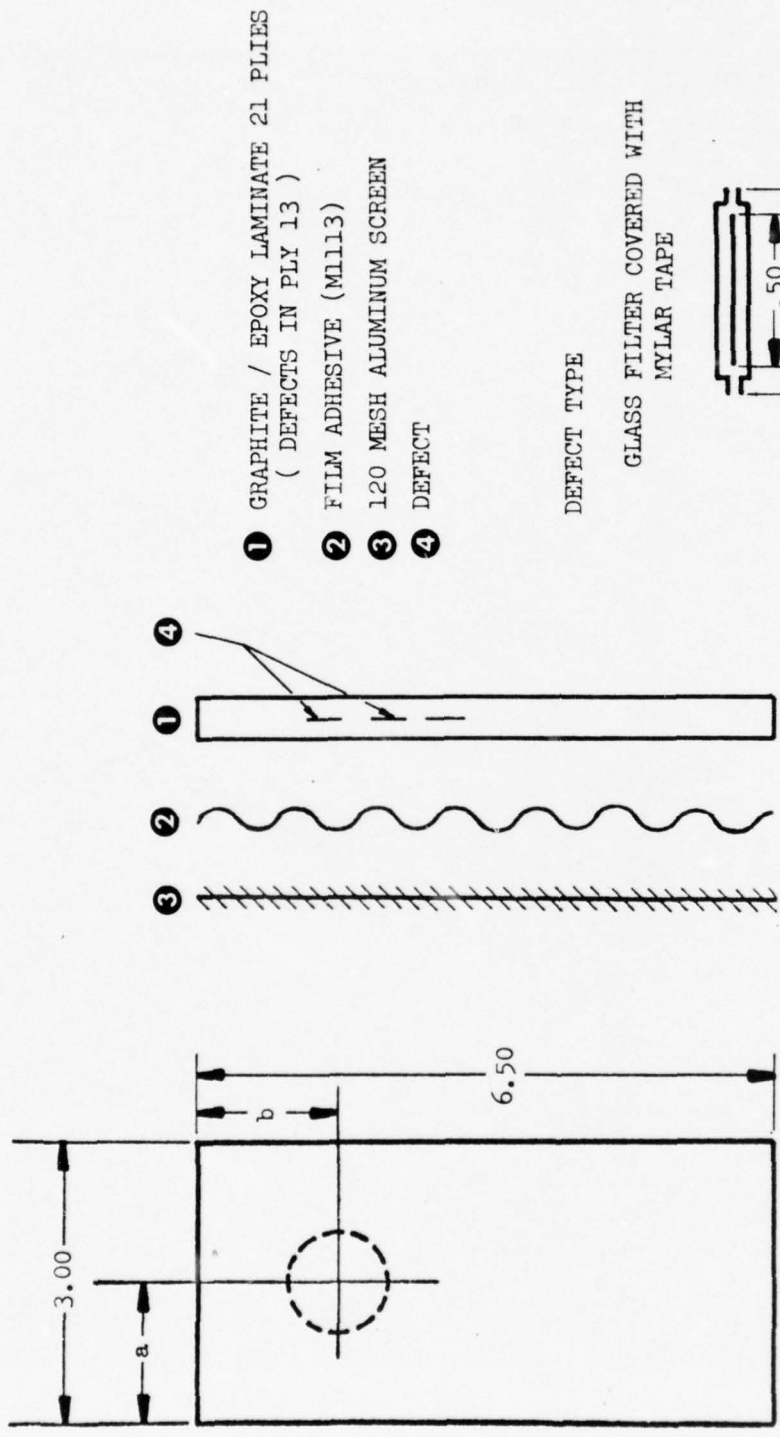

FIGURE 29: ULTRASONIC RECORD OF # 2 STATIC SPOILER IN AREA OF SKIN PLY VARIATION



OUTBOARD —

FIGURE 30: RADIOGRAPH OF #2 STATIC SPOILER IN AREA OF SKIN PLY VARIATION



- 1 GRAPHITE / EPOXY LAMINATE 21 PLYS
(DEFECTS IN PLY 13)
- 2 FILM ADHESIVE (M1113)
- 3 120 MESH ALUMINUM SCREEN
- 4 DEFECT

DEFECT TYPE

GLASS FILTER COVERED WITH
MYLAR TAPE



SPECIMEN NO.	a dim	b dim
QCDS-6	1.69	1.31
QCDS-7	1.31	5.19
QCDS-8	1.50	3.25
QCDS-9	1.31	1.31
QCDS-10	1.69	5.19

FIGURE 31: QCDS-6 THRU QCDS-10 SPECIMEN DETAIL

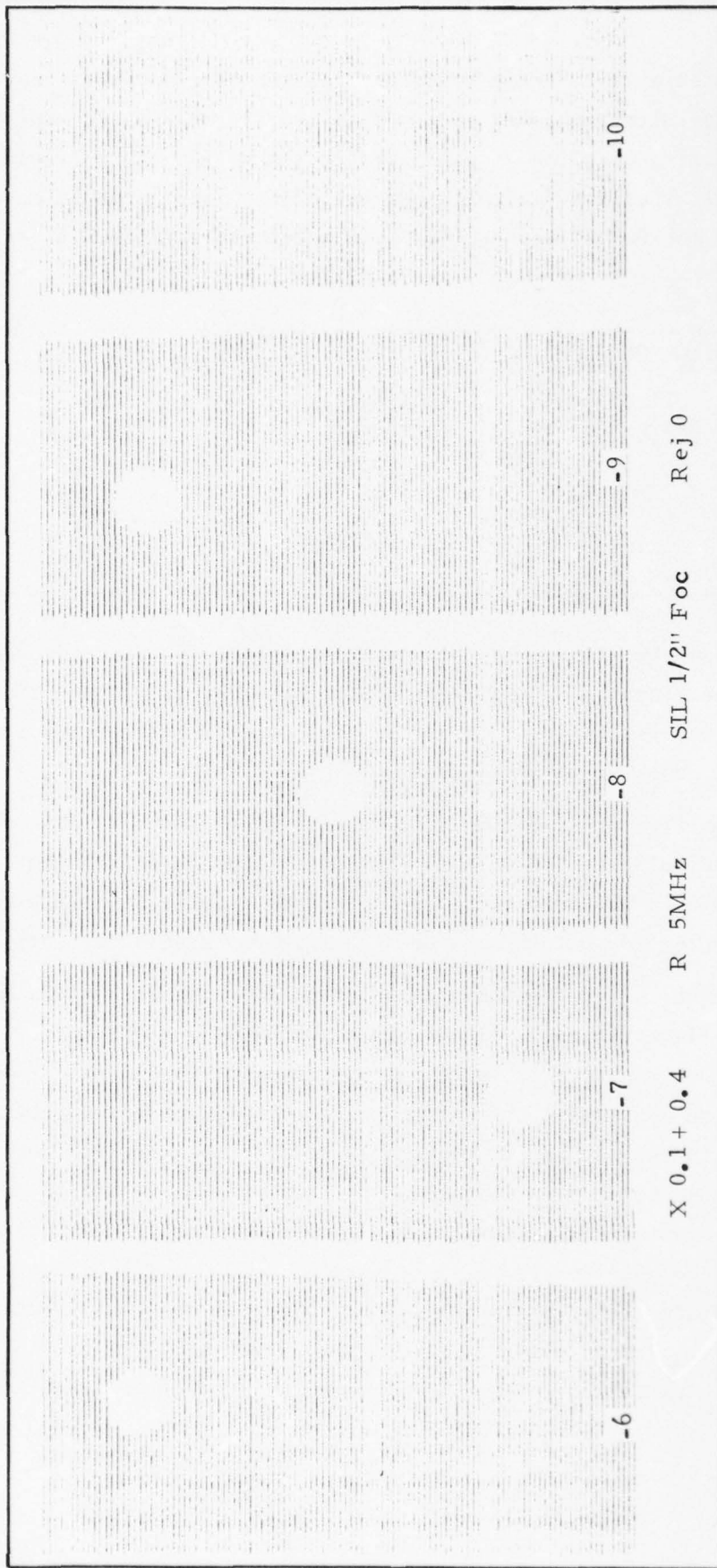

FIGURE 32: ULTRASONIC RECORD OF QCDS -6 THRU -10 AT X 0.1 + 0.4

honeycomb with added skin is referred to as Area 2; the section which represents the spoiler edge with the added core and skin stiffener is referred to as Area 1. Configuration details are presented in Figure 33. Several defects were simulated in this specimen including two which were fabricated by removing adhesive from the bond line and four with added glass filters covered with mylar tape.

TABLE I EFFECT OF BLEEDING ON THICKNESS AND FIBER VOLUME

Specimen Number	Plies of Resin Bleeder	Average Thickness	Fiber Volume %
QCDS-6	14	0.1212	66.6
-7	10	0.1216	66.7
-8	7 (optimum)	0.1211	66.7
-9	3	0.1292	65.0
-10	0	0.1371	59.8

Figures 34 and 35 show the ultrasonic through transmission C-scan recordings at two sensitivity settings. The two areas where adhesive was removed are not detected due to the filling of these areas with epoxy from the composite material, or flow of adhesive into the area.

Figure 36 shows a positive print of radiographs made of the panel. A view with the beam perpendicular to the skin surface and a view made with the beam parallel to the skin surface are shown. The four defects created with added material are detected, but those where adhesive was removed are not.

Evaluation of this panel using the Sonic unit showed that the area containing the precured tab stiffener (Area 1, Figure 33) gave slightly different responses than the area representative of the main body of the spoiler (Area 2, Figure 33). Figure 37 shows a photograph of the instrument display obtained when using a through transmission mode in the precured tab stiffener section (Area 1; transmitting with 2.25 MHz and receiving with 1 MHz transducers). Figure 38 shows the display when the transducers are placed over a built-in defect. The displays shown in Figures 39 and 40 are those obtained when placing the transducers in corresponding positions in the other section of the panel (Area 2). The displays in Areas 1 and 2 are similar, but the gain settings were: Coarse 4 and Fine 7 for Area 1 while in Area 2 settings were Coarse 6, Fine 5.

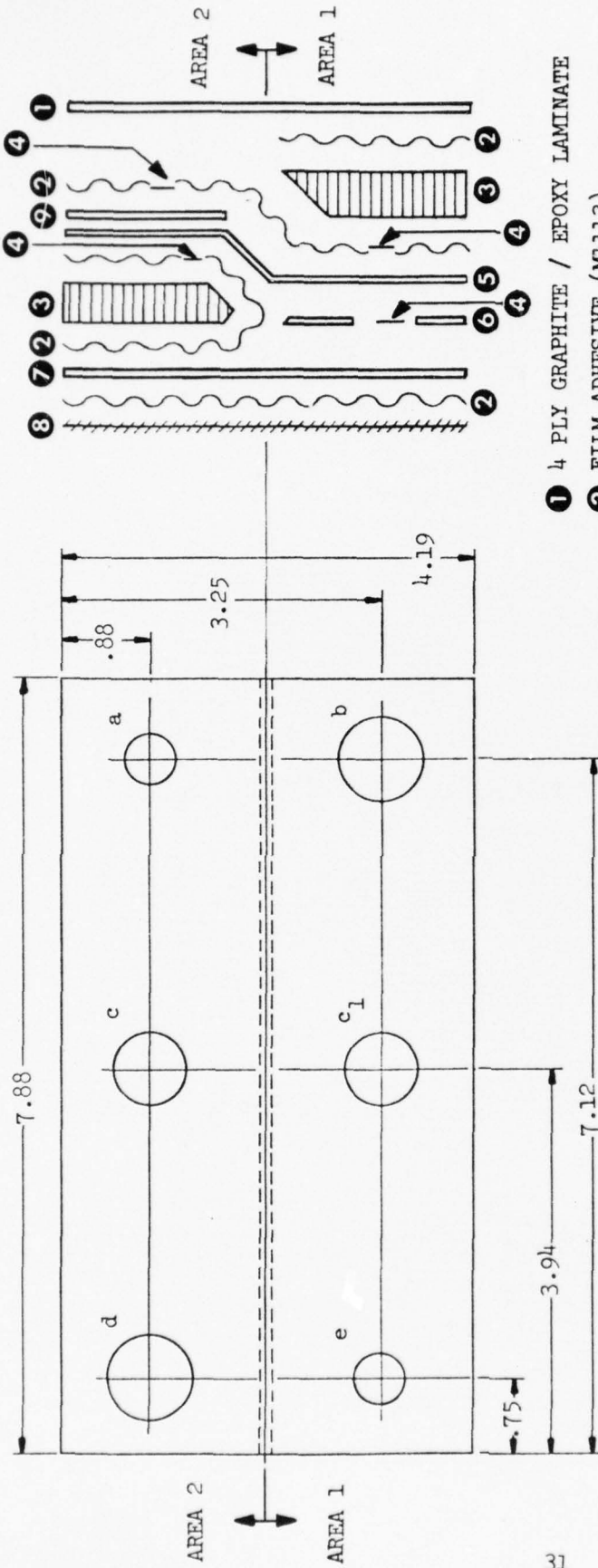

31

- 1 4 PLY GRAPHITE / EPOXY LAMINATE
- 2 FILM ADHESIVE (M1113)
- 3 HRP CORE
- 4 DEFECT OR VOID
- 5 8 PLY GRAPHITE / EPOXY LAMINATE
- 6 5 PLY GRAPHITE / EPOXY LAMINATE (DEFECT IN TOP PLY)
- 7 8 PLY GRAPHITE / EPOXY LAMINATE
- 8 120 MESH ALUMINUM SCREEN
- 9 2 PLY GRAPHITE / EPOXY LAMINATE

DEFECT INFORMATION

DEFECT	d dim	D dim	TYPE	LOCATION
a	.50	.62	glass & mylar	in adhesive above 8 ply laminate
b	.88	1.00	" "	" " " " " "
c	.75	.88	" "	in adhesive between core and 8 ply upper laminate
c ₁	.75	.88	" "	in top ply of 5 ply laminate
d	-	1.00	void only	in adhesive above upper 8 ply laminate
e	-	.62	void only	" " " " " "

FIGURE 33: QCDS-11 SPECIMEN DETAIL



FIGURE 34: QCDS -11 ULTRASONIC RECORD AT X1+7

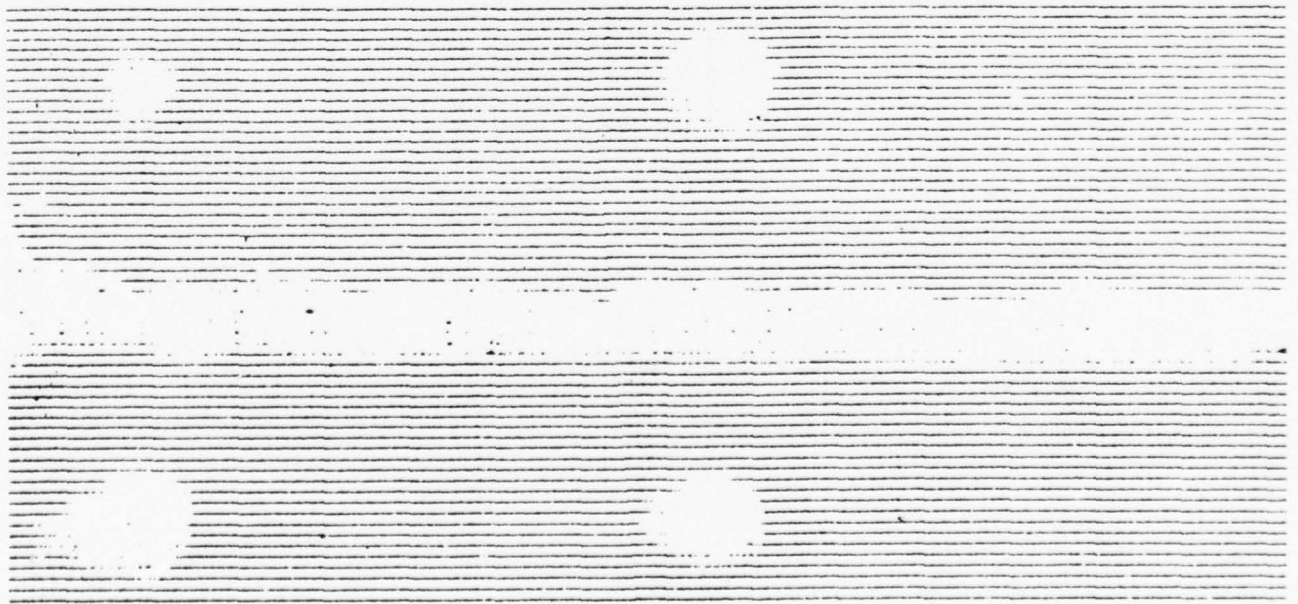
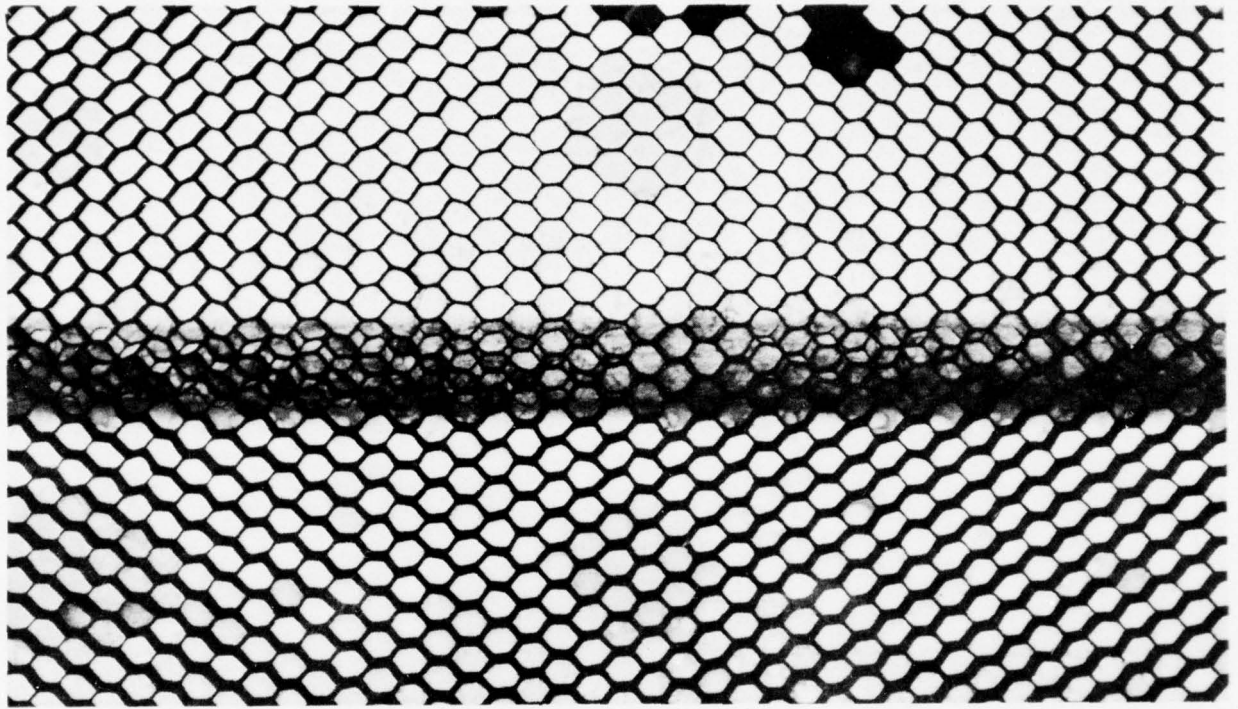
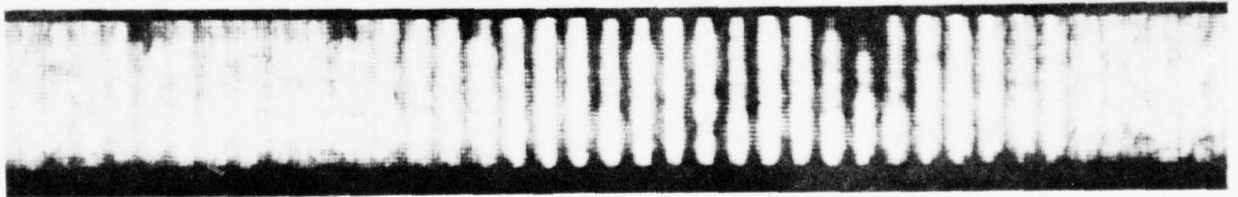

FIGURE 35: QCDS -11 ULTRASONIC RECORD AT X10+1



PLAN VIEW



EDGE VIEW

FIGURE 36: RADIOGRAPH'S OF QCDS-11 SPECIMEN

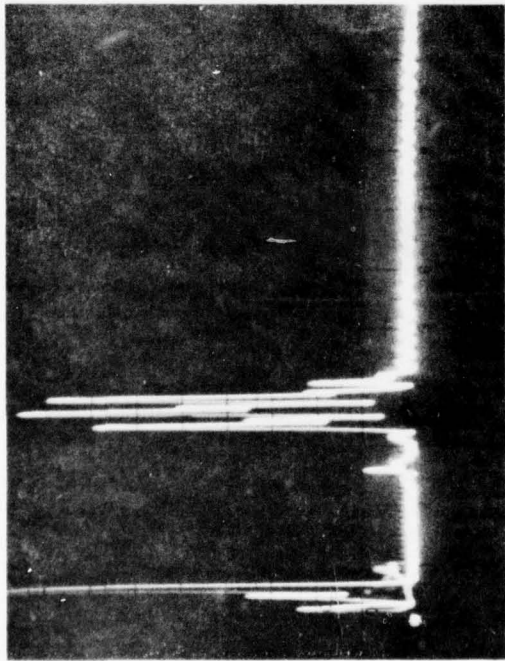

FIGURE 37: CRT SCOPE DISPLAY OF QCDS-II
AREA 1 FOR NORMAL COMPONENT

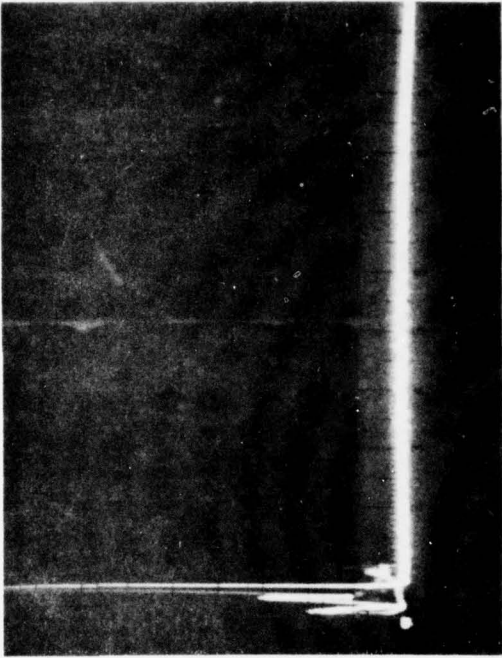

FIGURE 38: CRT SCOPE DISPLAY OF QCDS-II
AREA 1 FOR DEFECT

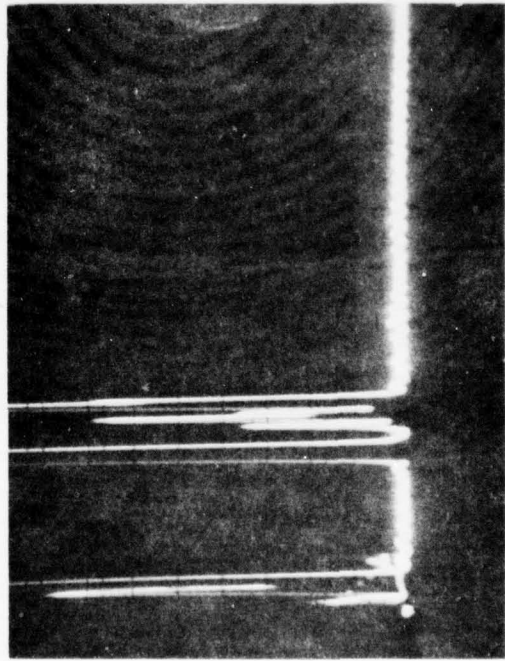

FIGURE 39: CRT SCOPE DISPLAY OF QCDS-II
AREA 2 FOR NORMAL COMPONENT

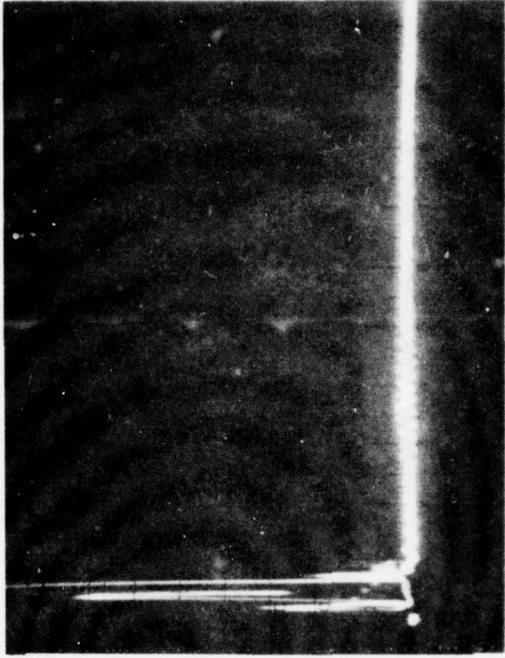
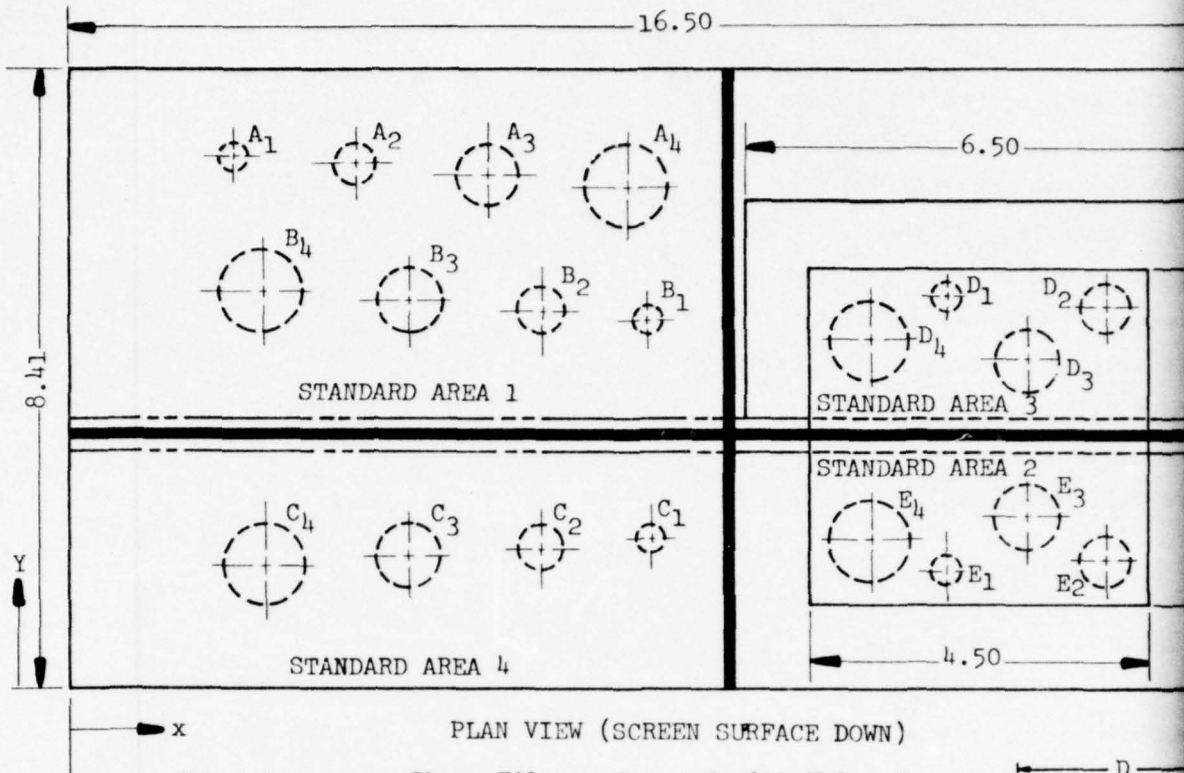

FIGURE 40: CRT SCOPE DISPLAY OF QCDS-II
AREA 2 FOR DEFECT

SECTION 3
FINAL REFERENCE STANDARDS

The information gained from the preliminary reference panels, QCDS-2 through -11 indicated that the composite spoiler should be inspected by calibration for four separate inspection areas: (1) the main honeycomb section, (2) the tab stiffener area which extends out over the solid laminate, (3) the tab stiffener area within the main honeycomb section, under the 2-ply skin doubler, and (4) the solid laminate edge. Three panels including each of these four areas were designed with each area containing four defects fabricated with glass fiber filters covered by mylar tape. Defect sizes range from 1/4 inch diameter to 1 inch diameter. Figure 41 shows details of the layout and construction of these panels which were designated QCDS-12, -13, and -14.

All materials and processes utilized during the fabrication were the same as those employed during the completion of contract H62269-74-C-0629. All exposed honeycomb was sealed to prevent introduction of moisture into the specimens. The same finish is applied to the specimens as that applied to the complete spoilers with the exception of the addition of a coat of white epoxy paint to the screen (aerodynamic) surface. Three panels were fabricated and cured together to try to obtain close duplication. The three panels are shown in Figure 42. Each of the three panels was evaluated using ultrasonic immersion through transmission, radiography and ultrasonic contact through transmission. Figures 43, 44, and 45 show reduced reproductions of the ultrasonic immersion through transmission C-scan recordings of a representative panel. Figure 43 shows the recording made for the solid laminate (Area 4) while Figures 44 and 45 shows recordings made at two gain settings for the honeycomb and tab stiffener (Areas 1, 2, and 3). A positive print of the radiograph of the panel is shown in Figure 46. Inspection techniques using contact ultrasonic through transmission are detailed in Appendix A. A procedure for each of the four standard areas is presented including step instructions, table of machine settings, a figure showing the standard specimen construction in the area which the procedure covers and two scope displays of the standard showing the CRT response to normal and defective construction.



All Defects are Glass Filters Covered with Mylar Tape

DEFECT	DEFECT SIZES		DEFECT LOCATIONS		REMARKS
	d	D	x	y	
A ₁	.250	.275	2.15	7.25	Located in lower skin to core bond line STANDARD AREA 1
A ₂	.500	.625	3.75	7.15	
A ₃	.750	.875	5.50	7.00	
A ₄	1.000	1.125	7.60	6.85	
B ₁	.250	.375	7.85	5.00	Located in upper skin to core bond line STANDARD AREA 1
B ₂	.500	.625	6.35	5.15	
B ₃	.750	.875	4.55	5.30	
B ₄	1.000	1.125	2.50	5.40	
C ₁	.250	.375	7.85	2.00	Located in ply 13 of edge band (solid laminate) STANDARD AREA 4
C ₂	.500	.625	6.35	1.85	
C ₃	.750	.875	4.55	1.70	
C ₄	1.000	1.125	2.50	1.55	
D ₁	.250	.375	12.10	5.35	Located in bond line between tab skin and upper skin STANDARD AREA 3
D ₂	.500	.625	14.10	5.30	
D ₃	.750	.875	13.00	4.65	
D ₄	1.000	1.125	10.85	4.75	
E ₁	.250	.375	12.10	1.55	Located in bond line between tab honeycomb and edge laminate. STANDARD AREA 2
E ₂	.500	.625	14.10	1.75	
E ₃	.750	.875	13.00	2.35	
E ₄	1.000	1.125	10.85	2.00	

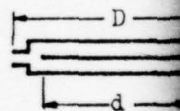

- 1.
- 2.
- 3.
- 4.
- 5.
- 6.
- 7.
- 8.
- 9.

FIGURE 41: FINAL STANDARD SPECIMEN DET

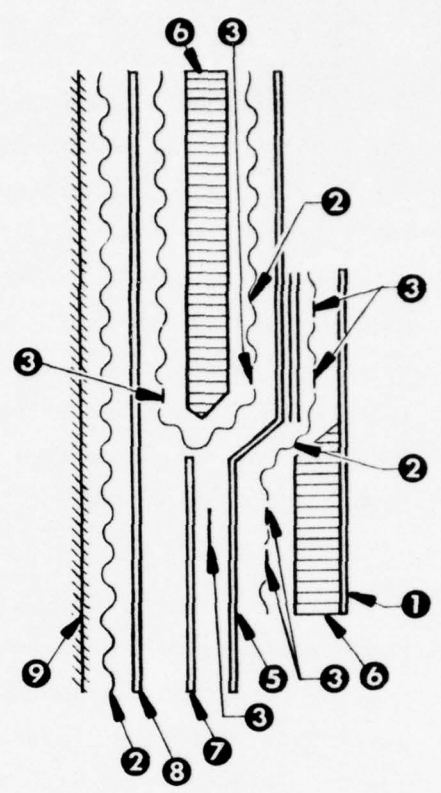
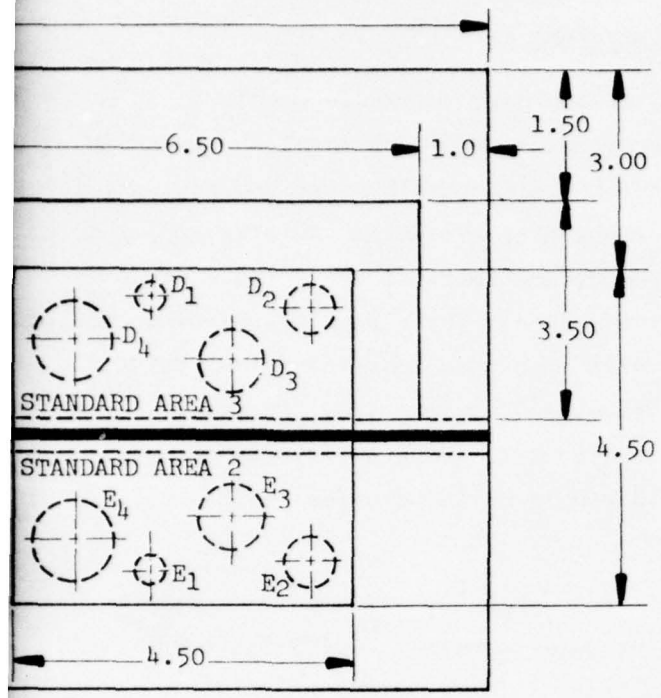

(E DOWN)

Mylar Tape

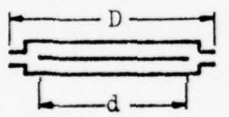

tin to core
tin to core
of edge band
se between skin
se between edge

1. Simulated tab stiffener (fabricated from material made for contract N 62269-74-C-0629)
2. Film adhesive (M1113)
3. Defects
4. Two ply 0° doubler (simulates outbd hinge area)
5. 8 ply upper skin
6. HRP core
7. 5 ply (+ 45°) spacer
8. 8 ply lower skin
9. 120 mesh aluminum screen

STANDARD SPECIMEN DETAIL (QCDS-12, -13 & 14)

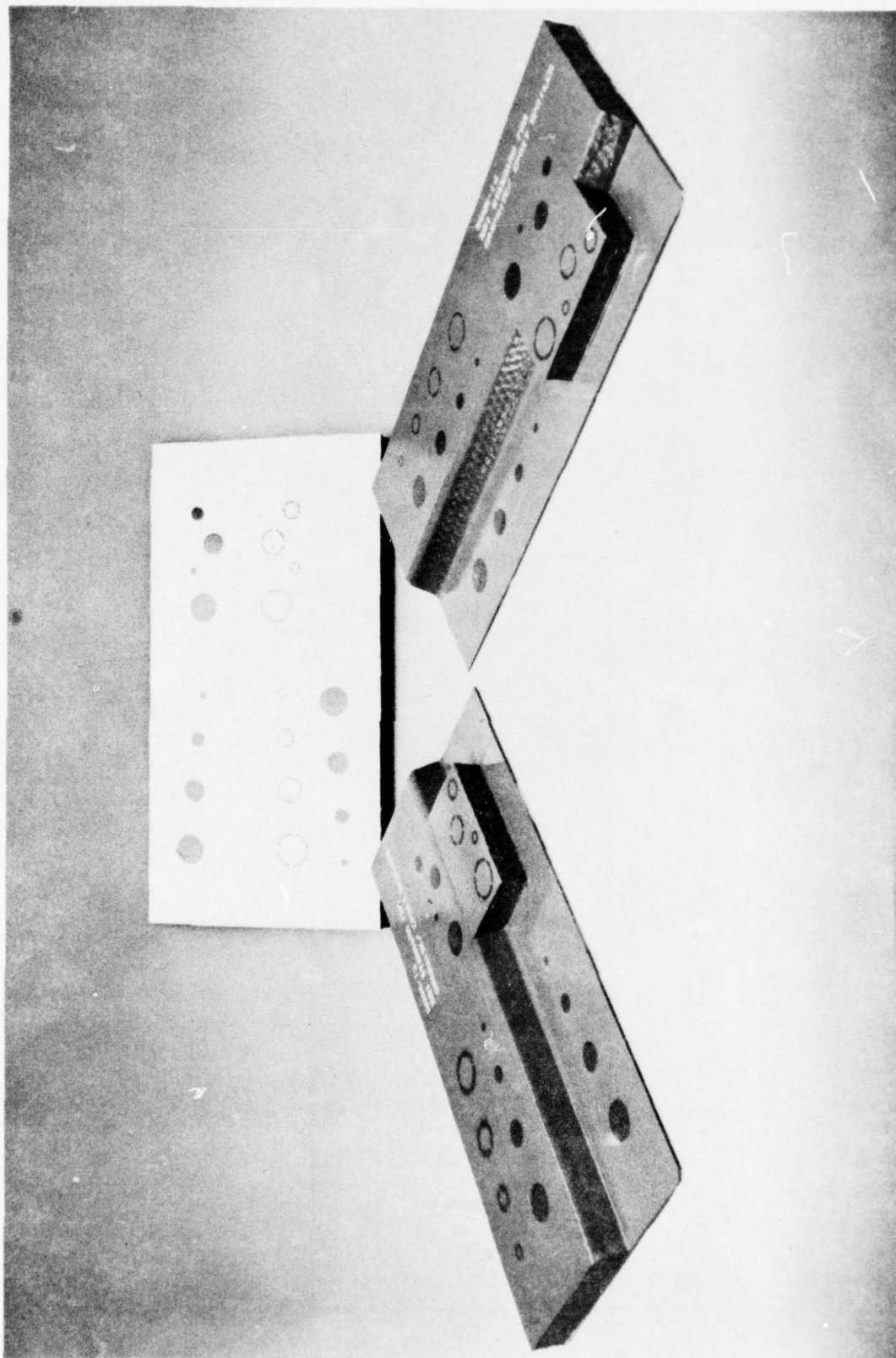

FIGURE 42: FINAL STANDARD SPECIMENS, QCDS-12, -13 AND -14

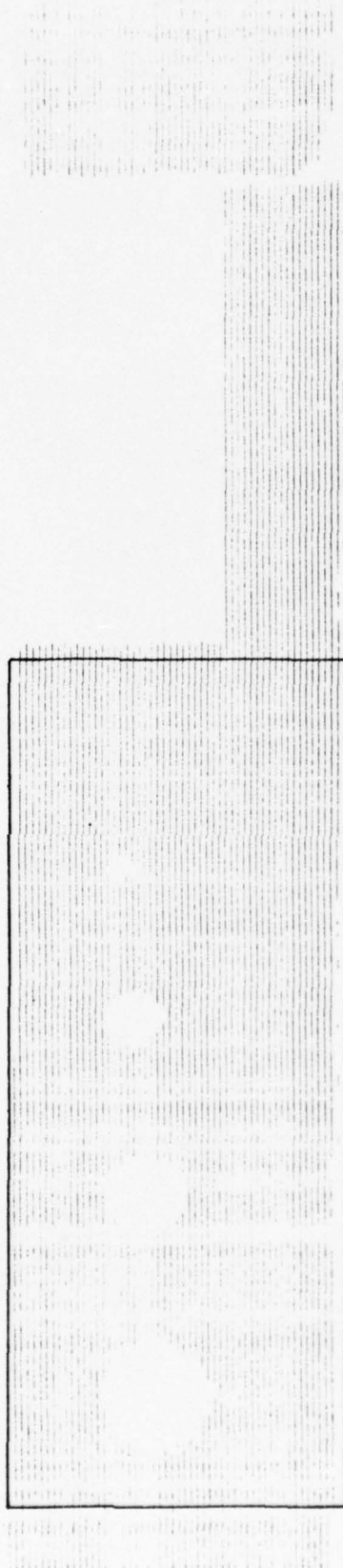

FIGURE 43: ULTRASONIC RECORD OF AREA 4 (SOLID LAMINATE)

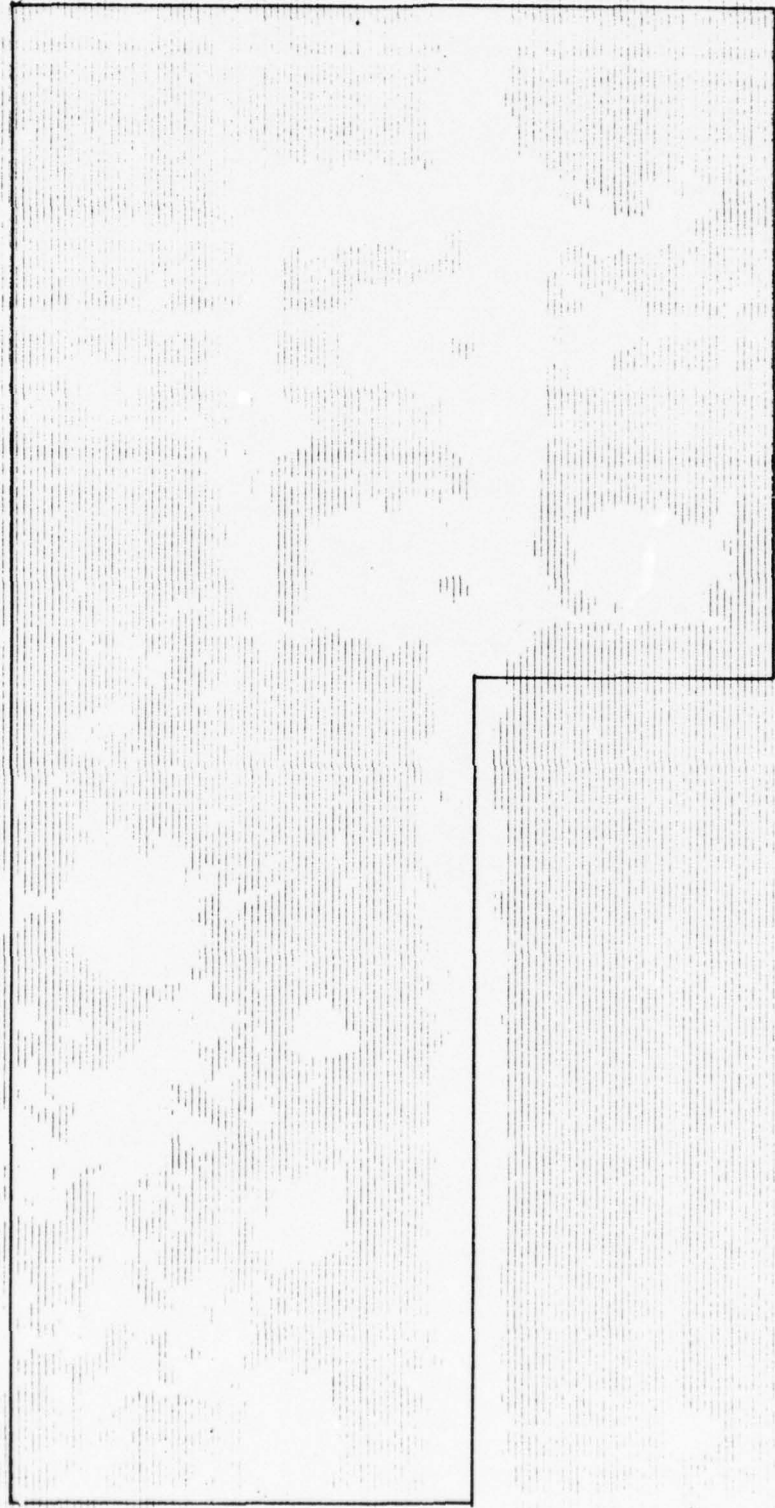

FIGURE 44: ULTRASONIC RECORD OF AREAS 1, 2 & 3
(HONEYCOMB AND TAB) AT X10+3.6

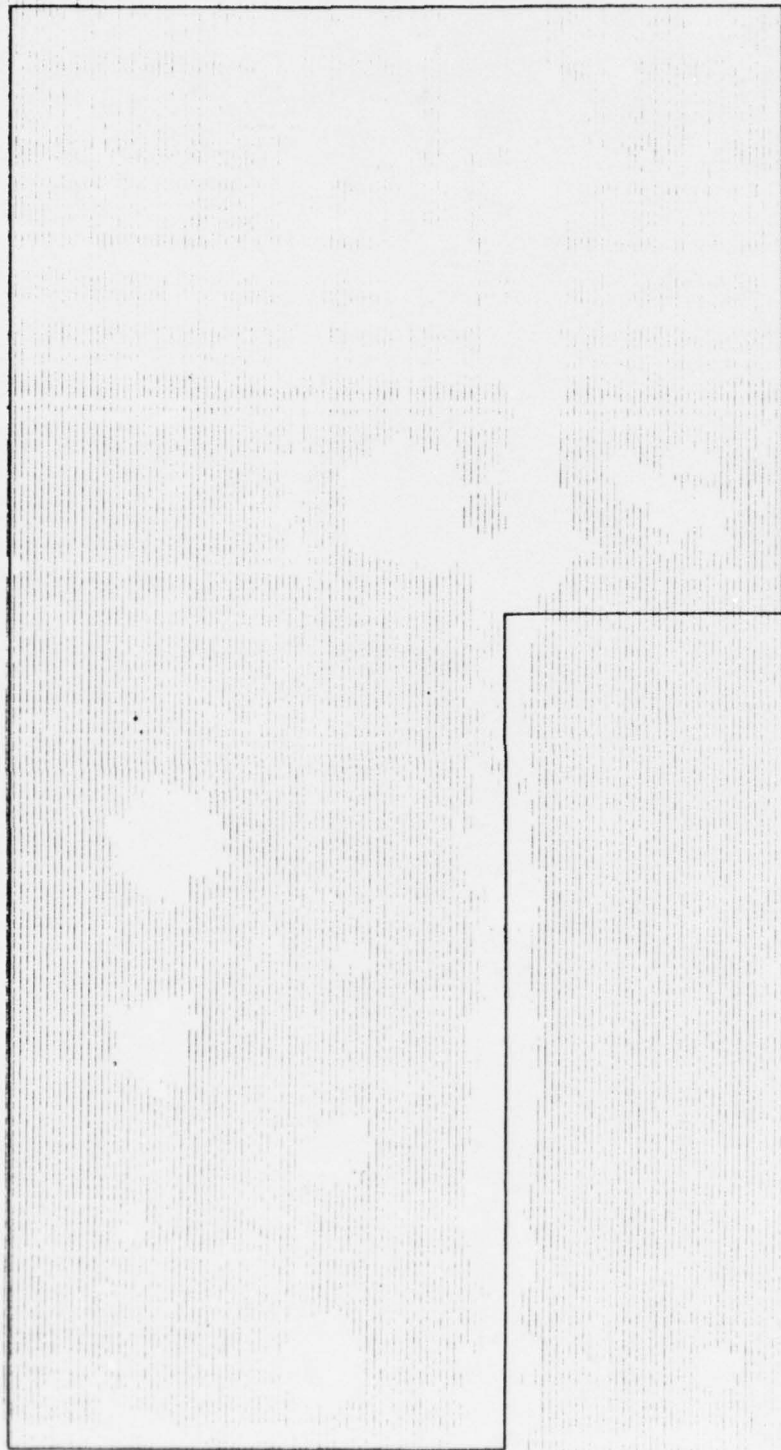

FIGURE 45: ULTRASONIC RECORD OF AREAS 1, 2 & 3
(HONEYCOMB AND TAB) AT X10+5

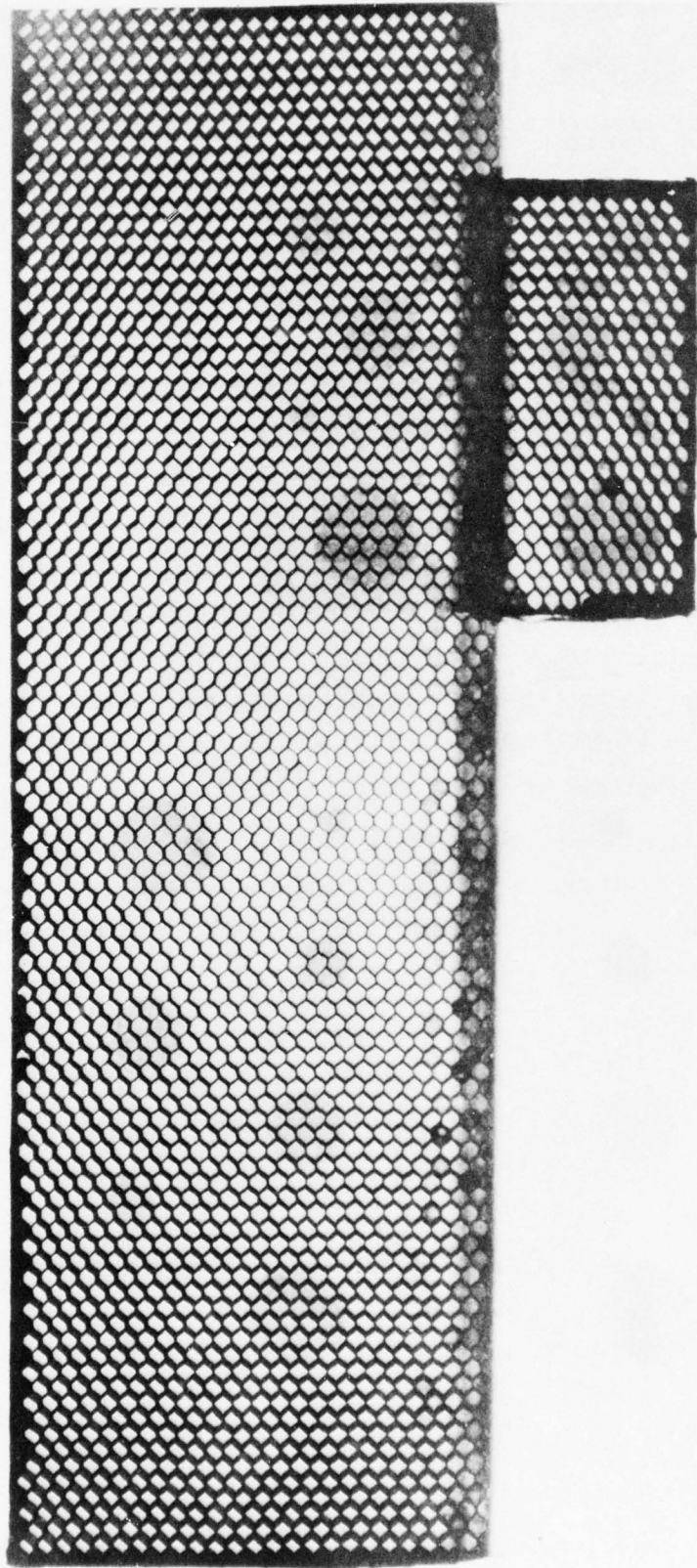

FIGURE 46: RADIOGRAPH OF FINAL STANDARD SPECIMEN

SECTION 4
CONCLUSIONS AND RECOMMENDATIONS

As a result of the work done and reported on in the preceding sections, several conclusions and recommendations have been made. Contact ultrasonic through transmission is a reliable and sensitive method which will allow the detection of delaminations or debonds as small as 1/4" in diameter in the solid laminate areas or 1/2" in diameter in the honeycomb areas of the composite spoiler. It should be remembered that with any contact inspection method, the surface preparation of the part being inspected can have great influence on results. Every effort should be made to insure a clean, smooth surface for inspection.

Ultrasonic through transmission, as detailed for inspection of the composite spoiler, does have some limitations. Through transmission, can locate and define the dimensions of a delamination or debond but does not provide information concerning the distance of the defect from the surface of the part. It also should be noted that with through transmission it is possible to increase the sensitivity setting so that ultrasonic waves being driven around a small defect can be detected.

Other techniques for backup and for providing additional information about a defect located with ultrasonic through transmission are being investigated and will be reported in report Number NADC-76234-30 under contract Number 62269-75-C-0428.

S-3A GRAPHITE/EPOXY SPOILER INSPECTION PROCEDURE

I. This ultrasonic procedure will be used to detect delaminations or debonds in skins or adhesive bondlines.

II. Equipment

1. Ultrasonic Flaw Detector manufactured by Sonic Instruments, Inc.
(Federal Stock No. 6RX6635-070-6669-5X-7X)
2. Transducers
2.25 MHz, 0.5" diameter, Type LZ-C2
1.0 MHz, 0.5" diameter, Type SFZ
3. Cable, two - 8 ft. microdot/BNC connectors
4. Transducer holder (see Fig. A-1) or equivalent
5. Couplant, water soluble cellulose base gel
6. Battery power unit, if applicable.

III. Access

Lower spoiler should be at maximum extension

IV. Preparation of Part

Surface of part must be clean and free of such surface irregularities as blistered or chipped paint.

V. Procedure

1. Place transducers in holder. Attach cables to transducers. Attach cable from 2.25 MHz transducer to "T" receptacle and 1 MHz transducer cable to "R" receptacle on instrument. Turn on instrument for warm up.
2. Select area of inspection using inspection area/reference standard usage instruction, Figure A-2. Turn to procedure sheet specified for this area and follow calibration and inspection instructions.
3. Inspect all of the selected area before proceeding to another area of inspection.

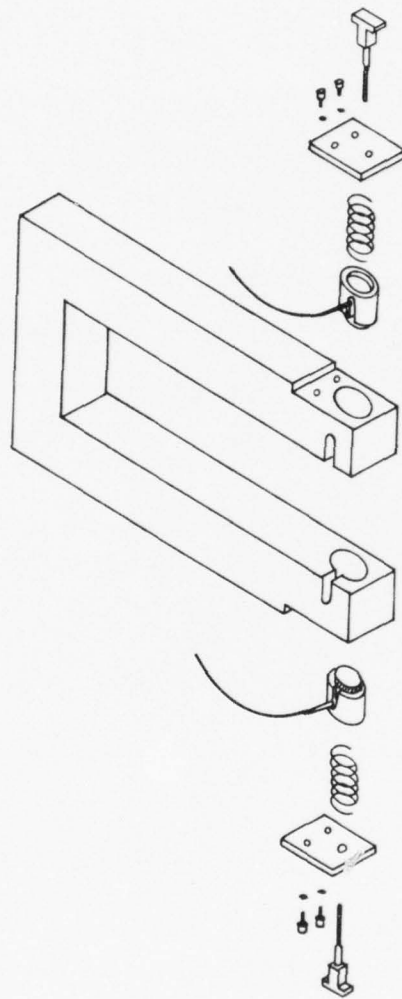
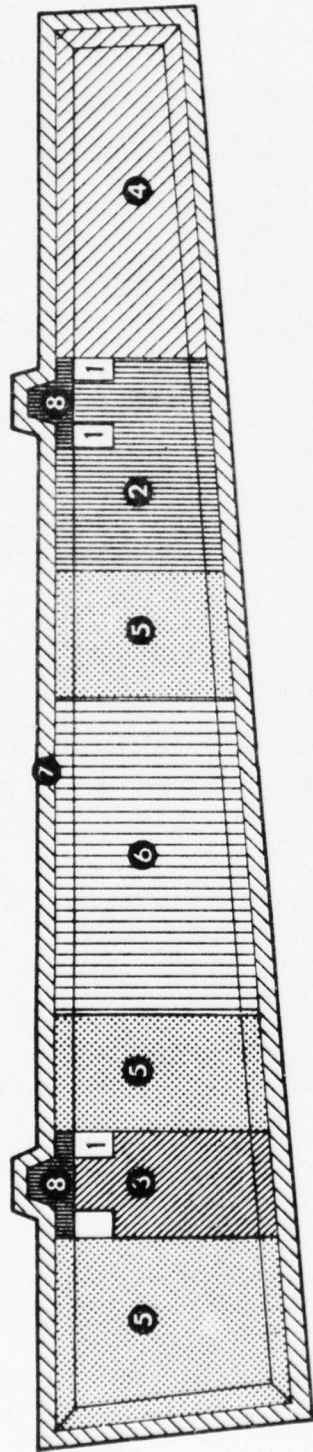

FIGURE A-1: TRANSDUCER HOLDER



LOWER SPOILER ZONE CHART

← INBD

SPOILER	STANDARD
Zone 1	Area 3
Zone 2	Area 1
Zone 3	Area 1
Zone 4	Area 1
Zone 5	Area 1
Zone 6	Area 1
Zone 7	Area 4
Zone 8	Area 2

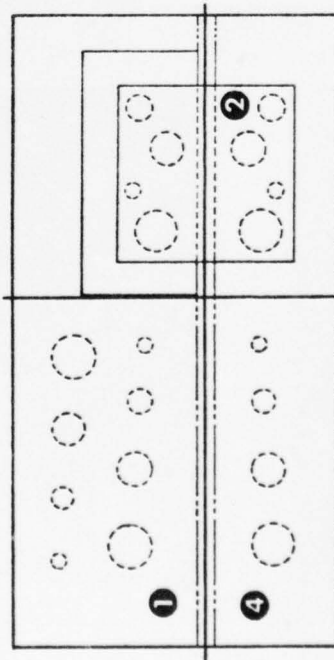

REFERENCE STANDARD AREAS

Procedure Sheet	1	Applies To	Area	1	Inspection
"	2	"	"	2	"
"	3	"	"	3	"
"	4	"	"	4	"
"	4A	"	"	4	"

FIGURE A-2: SPOILER INSPECTION ZONE / REFERENCE STANDARD AREA COORDINATION

PROCEDURE

Inspection Area - Honeycomb section of spoiler, excluding tab stiffener area.

Reference Standard - Area 1

Procedure

1. Place couplant on both surfaces of Area 1 on Reference Standard.
2. Place transducers in holder on Area 1 of Reference Standard, with 2-25MHZ transducer on inner surface (red surface) of standard.
3. Adjust spring tension on holder to obtain tight fit on standard.
4. Position transducers in an area where there is no marked defect. Adjust instrument initial setting as shown in Table A-1.
5. Adjust gain controls, if necessary, to produce the display shown in Figure A-4.
6. Move transducers over largest marked defect. Display should be as in Figure A-5.
7. Slide transducer holder off and on marked defects, checking tension adjustment, good coupling and responses shown on display.
8. Place couplant on both surfaces of spoiler in area of inspection.
9. Position transducer holder on spoiler. Compare display to that obtained on reference panel. (Figure A-4, and Figure A-5)
10. Slide transducers to scan within defined limits of inspection area, taking care to assure adequate coupling between transducers and spoiler.
11. A display like that shown in Figure A-5 will indicate a probable delamination or debond.
12. Mark and report defect indications.

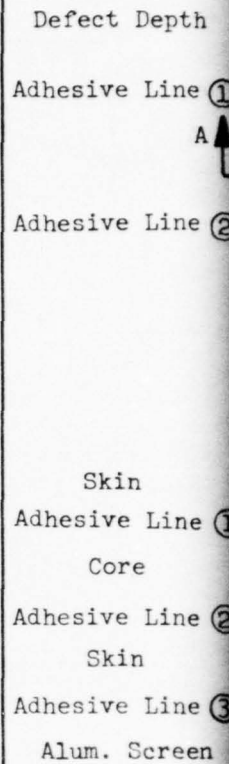

FIGUR



FIGURE A-1

PROCEDURE 1

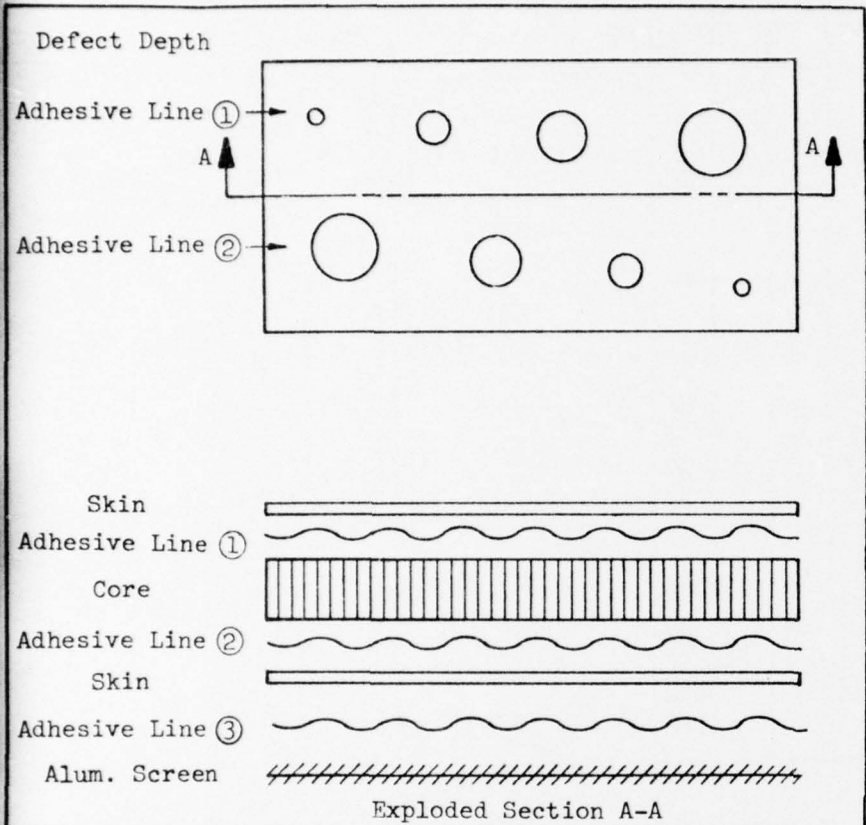

TABLE A-1, MACHINE SETTINGS
AREA 1

Sweep Range	Coarse <u>1</u> Fine <u>4</u>
Sweep Delay	Coarse <u>0-3</u> Fine <u>Max</u>
Attenuator	<u>all down</u>
Gain	Coarse <u>6</u> Fine <u>0</u>
Reject	<u>8</u>
Freq. - MHz	<u>1.0</u>
Damping	<u>7</u>
Mode	<u>Thru</u>
Rep. Rate	<u>Auto</u>
Filter	<u>on</u>

FIGURE 3. AREA 1 DEFECT LOCATIONS

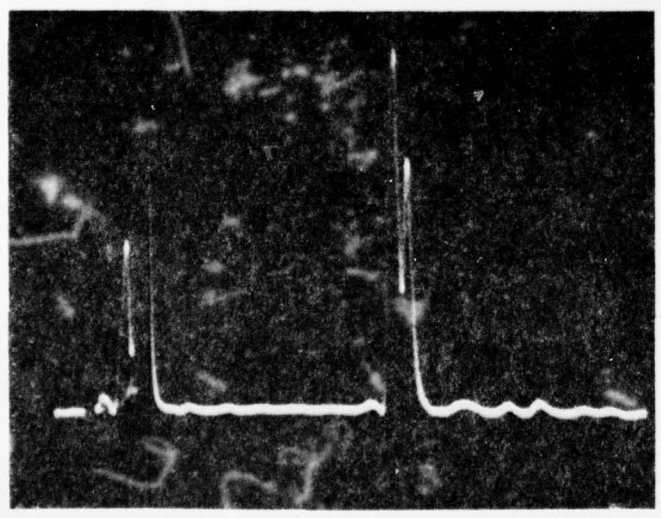

FIGURE A-4: SCOPE DISPLAY FOR NORMAL RESPONSE IN AREA 1

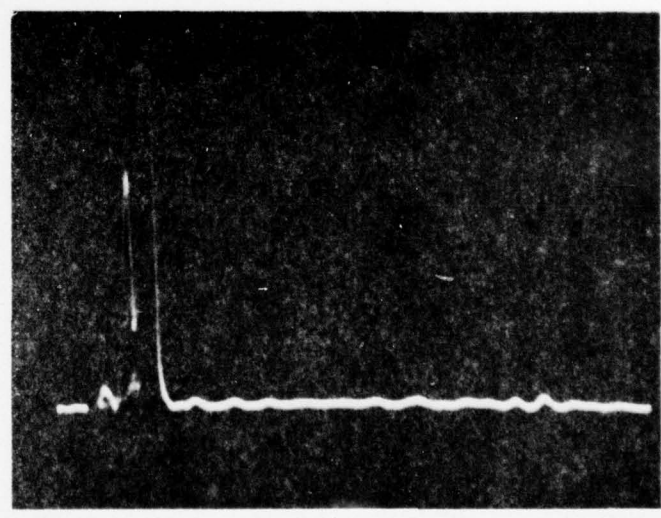

FIGURE A-5: SCOPE DISPLAY FOR DEFECT IN AREA 1

Inspection Area - Tab stiffener area which extends over solid laminate edge.

Reference Standard - Area 2

PROCEDURE

1. Place couplant on both surfaces of Area 2 on Reference Standard.
2. Place transducers in holder on Area 2 with 2.25 MHz transducer on inner (red) surface of **standard**.
3. Adjust spring tension on holder to obtain tight fit on **standard**.
4. Position transducers in an area where there is no marked defect. Adjust initial instrument settings as shown in Table A-II.
5. Adjust gain controls, if necessary, to produce the display shown in Figure A-7.
6. Move transducers over largest marked defect. Display should be as in Figure A-8.
7. Slide transducer off and on marked defects, checking tension adjustment, good coupling, and responses shown on display.
8. Place couplant on both surfaces of spoiler in area of inspection. Note that this area is very limited in size and careful positioning of transducers is necessary.
9. Position transducer holder on spoiler. Compare display to that obtained on reference panel. (Figure A-7 and Figure A-8)
10. Slide transducers to scan within defined limits of inspection area, taking care to assure adequate coupling between transducers and spoiler. Note that definite edge effects are obtained if transducers extend over the edge of the part.
11. A display like that shown in Figure A-8 will indicate a probable delamination or debond.
12. Mark and report defect indications.

Tab Sti

Adhe
Ski
Doub
Ski

Alum. S

Fl

FIGUR

PROCEDURE 2

TABLE A-II, MACHINE SETTINGS
AREA 2

Sweep Range	Coarse <u>1</u> Fine <u>5</u>
Sweep Delay	Coarse <u>0-3</u> Fine <u>Max</u>
Attenuator	All Down
Gain	Coarse <u>4</u> Fine <u>8</u>
Reject	7
Freq-MHz	1.0
Damping	7
Mode	Thru
Rep. Rate	Auto
Filter	on

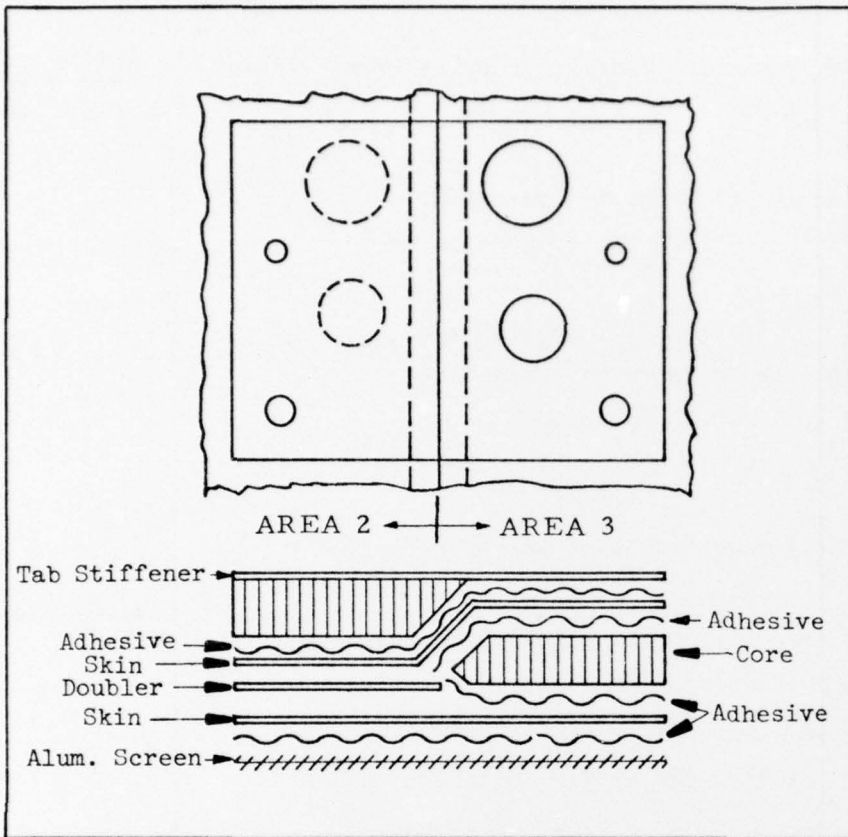

FIGURE 6. AREA 2 AND AREA 3 DEFLECTION LOCATIONS

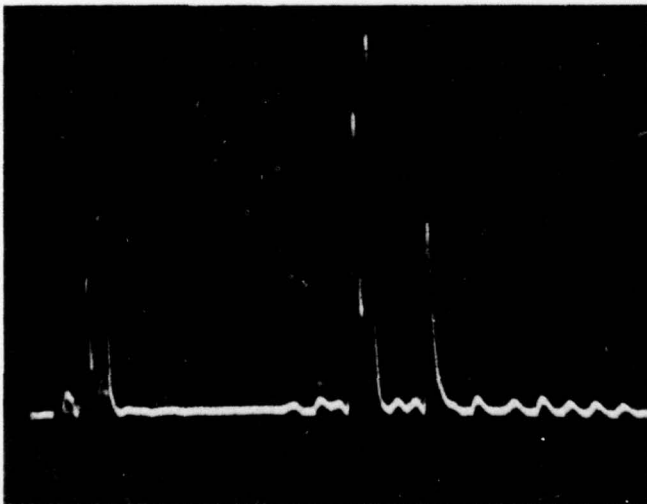

FIGURE A-7: SCOPE DISPLAY OF NORMAL RESPONSE IN AREA 2

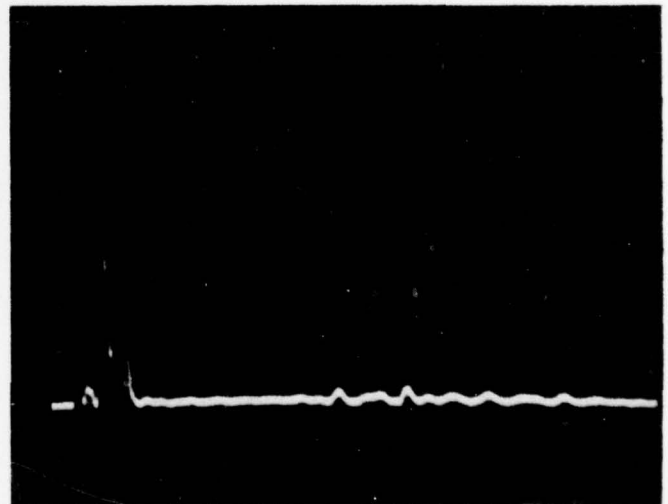

FIGURE A-8: SCOPE DISPLAY OF DEFECT IN AREA 2

Spoiler Inspection Area - Tab stiffener area which extends into honeycomb section.

Reference Standard - Area 3 - See Figure A-6.

Procedure:

1. Place couplant on both surfaces of Area 3 on Reference Standard.
2. Place transducers in holder on Area 3 with 2.25 MHz transducer on inner (red) surface of standard.
3. Adjust spring tension on holder to obtain tight fit on standard.
4. Position transducers in an area where there is no marked defect. Adjust initial instrument settings as shown in Table A-III.
5. Adjust gain control, if necessary, to produce the display shown in Figure A-9.
6. Move transducers over largest marked defect. Display should be as in Figure A-10.
7. Slide transducer off and on marked defects, checking tension adjustment, good coupling, and responses shown on display.
8. Place couplant on both surfaces of spoiler in area of inspection. Note that this area is very limited in size and careful positioning of transducers is necessary.
9. Position transducer holder on spoiler. Compare display to that obtained on reference panel. (Figure A-9 and Figure A-10)
10. Slide transducers to scan within defined limits of inspection area, taking care to assure adequate coupling between transducers and spoiler. Note that definite edge effects are obtained if transducers extend over the edge of the 2 ply skin doubler.
11. A display like that shown in Figure A-10 will indicate a probable delamination or debond.
12. Mark and report defect indications.

PROC

Tab Stiff

Skin
Double
Skin
Alum. Se

FIGURE



FIGURE A

PROCEDURE 3

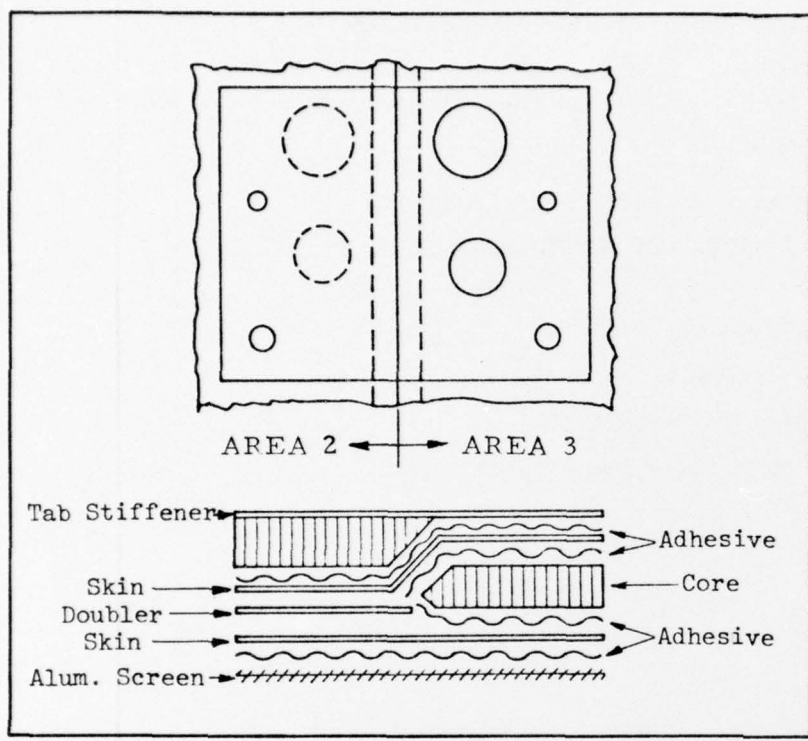

TABLE A-III, MACHINE SETTINGS AREA 3

Sweep Range	Course <u>1</u>	Fine <u>5</u>
Sweep Delay	Course <u>0-3</u>	Fine <u>Max</u>
Attenuator	<u>All Down</u>	
Gain	Course <u>6</u>	Fine <u>5</u>
Reject	<u>7</u>	
Freq-MHz	<u>1.0</u>	
Damping	<u>7</u>	
Mode	<u>Thru</u>	
Rep. Rate	<u>Auto</u>	
Filter	<u>On</u>	

FIGURE 6: AREA 2 AND AREA 3 DEFECTION LOCATIONS

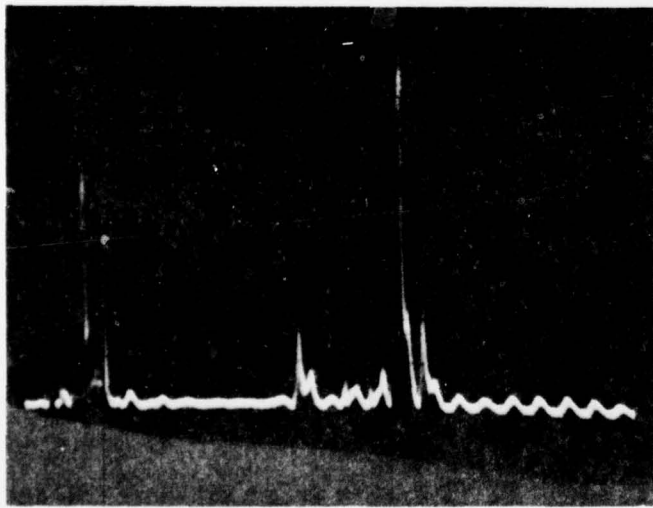

FIGURE A-9: SCOPE DISPLAY FOR NORMAL RESPONSE IN AREA 3

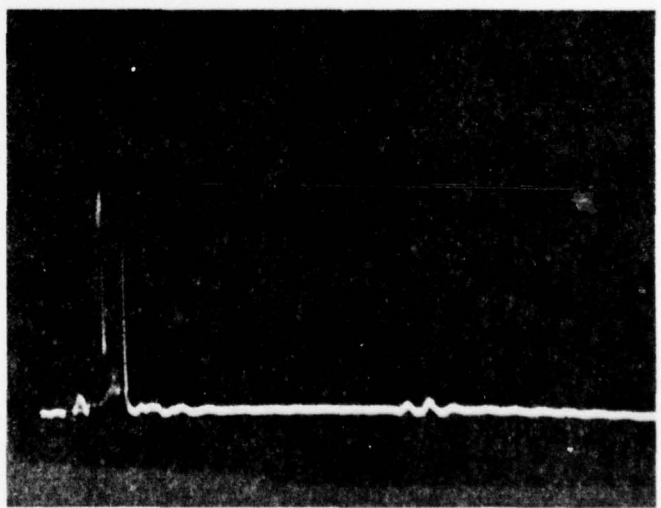

FIGURE A-10: SCOPE DISPLAY OF DEFECT IN AREA 3

Spoiler Inspection Area - Solid laminate leading edge

Reference Standard - Area 4

Procedure

1. Place couplant on both surfaces of Area 4 on Reference Standard.
2. Place transducers in holder on Area 4 of Reference Standard, with 2-2MHZ transducer on inner surface (red surface) of panel. Use adjustment washer in 2.25MHZ side of transducer holder to allow transducers to move closer together.
3. Adjust spring tension on holder to obtain tight fit on **standard**.
4. Position transducers in an area where there is no marked defect. Adjust instrument initial setting as shown in Table A-IV.
5. Adjust gain controls, if necessary, to produce the display shown in Figure A-12.
6. Move transducers over largest marked defect. Display should be as in Figure A-13.
7. Slide transducer holder off and on marked defect, checking tension adjustment, good coupling and responses shown on display.
8. Place couplant on both surfaces of spoiler in area of inspection.
9. Position transducer holder on spoiler. Compare display to that obtained on reference panel. (Figures A-12 and A-13)
10. Slide transducers to scan within defined limits of inspection area, taking care to assure adequate coupling between transducers and spoiler.
11. A display like that shown in Figure A-12 will indicate a probable delamination or debond
12. Mark and report defect indications.

PROCEDURE 4

TABLE A-IV, MACHINE SETTINGS
AREA 4

Sweep Range	Coarse <u>1</u>	Fine <u>2</u>
Sweep Delay	Coarse <u>0-3</u>	Fine <u>Max</u>
Attenuator	<u>All Down</u>	
Gain	Coarse <u>1</u>	Fine <u>9</u>
Reject	<u>7</u>	
Freq-MHz	<u>12</u>	
Damping	<u>7</u>	
Mode	<u>Thru</u>	
Rep. Rate	<u>Auto</u>	
Filter	<u>On</u>	

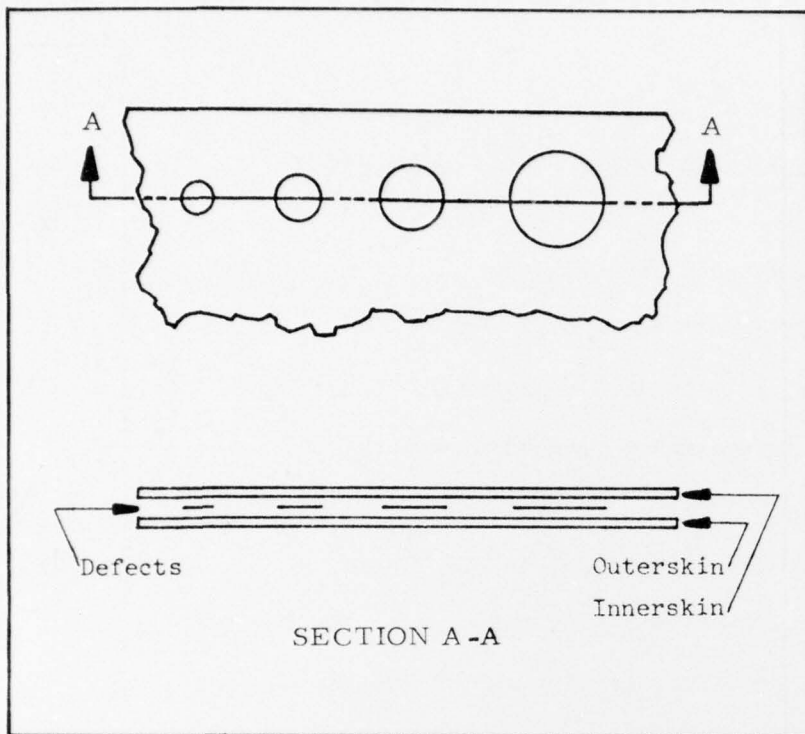

FIGURE A-11: AREA 1 DEFECT LOCATION

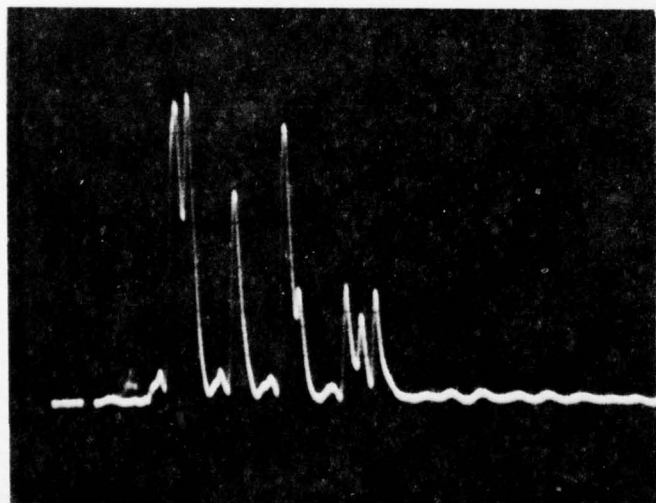

FIGURE A-12: SCOPE DISPLAY FOR NORMAL RESPONSE IN AREA 4

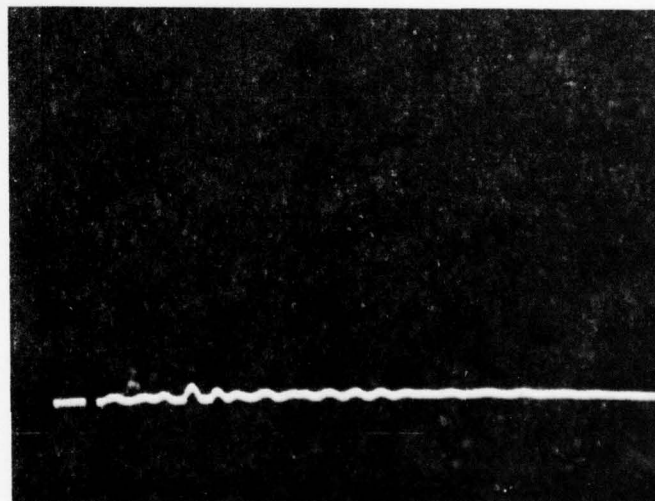

FIGURE A-13: SCOPE DISPLAY FOR DEFECT IN AREA 4

Spoiler Inspection Area - Solid Laminated Edge (Alternate Procedure)

Reference Standard - Area 4

1. Place couplant on inner (red) surface of Area 4 on Reference Standard.
2. Remove transducers from holder and disconnect 1.0 MHz transducer and cable from "R" post.
3. **Adjust** initial instrument settings as shown in Table A-V.
4. Place 2.25 MHz transducer in an area where there is no marked defect.
5. Adjust gain controls, if necessary, to produce display as in Figure A-14.
6. Adjust Fine Sweep Range Control to place major peak on a vertical grid mark.
7. Move transducer over largest marked defect. Major peak in display should shift one full unit to the left as in Figure A-15.
8. Place couplant on inner (red) surface of spoiler in area of inspection.
9. Place transducer on spoiler, **compare** display to that obtained on reference panel. (Figures A-14 and A-15)
10. Slide transducers to scan within defined limits of inspection area, taking care to assure adequate coupling between transducer and spoiler.
11. A display like that shown in Figure A-15 will indicate a probable delamination or debond.
12. Mark and report defect indications.

ALTE

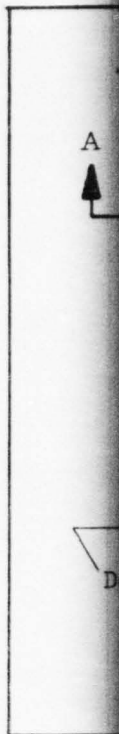

FIG

FIGURE

ALTERNATE PROCEDURE 4

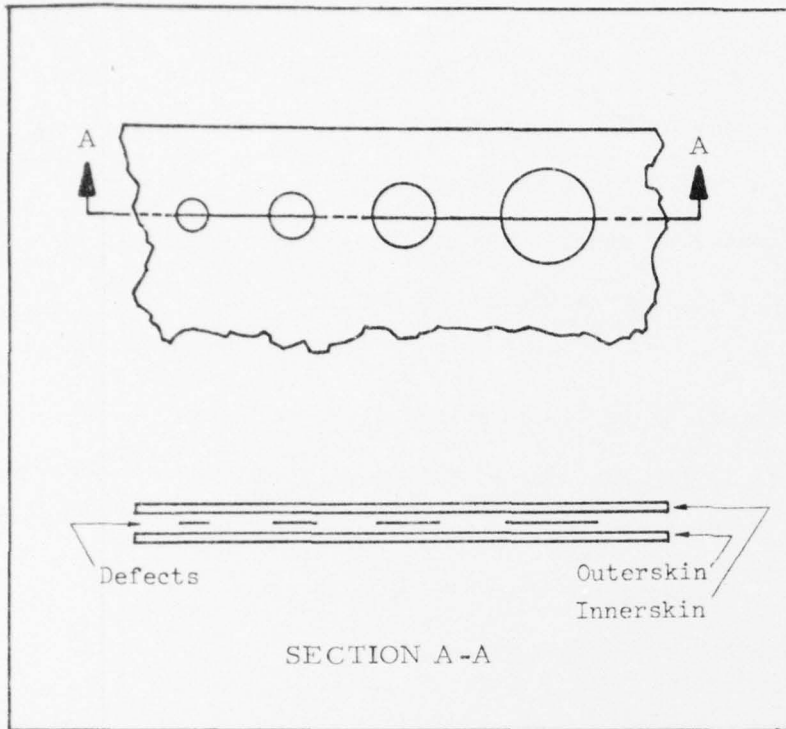

TABLE A-V, MACHINE SETTINGS
AREA 4

Sweep Range	Coarse <u>1</u> Fine <u>Min</u>
Sweep Delay	Coarse <u> </u> Fine <u>Max</u>
Attenuator	<u>All Down</u>
Gain	Coarse <u>2</u> Fine <u>2</u>
Reject	<u>6</u>
Freq-MHz	<u>2.25</u>
Damping	<u>Max</u>
Mode	<u>Pulse-Echo</u>
Rep. Rate	<u>Auto</u>
Filter	<u>on</u>

FIGURE A-11: AREA 1 DEFECT LOCATION

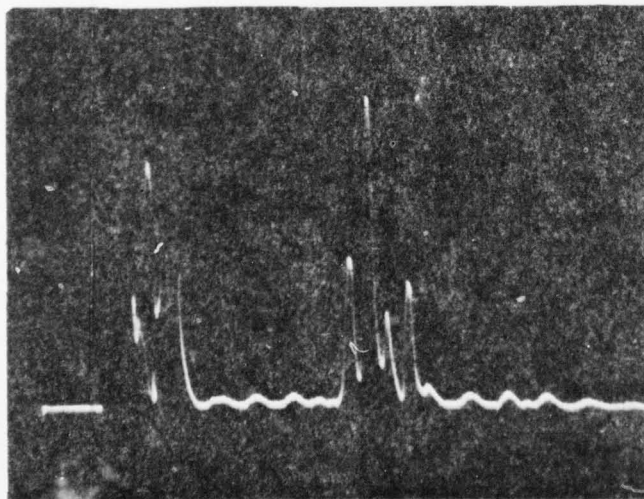

FIGURE A-14: SCOPE DISPLAY FOR NORMAL RESPONSE IN AREA 4

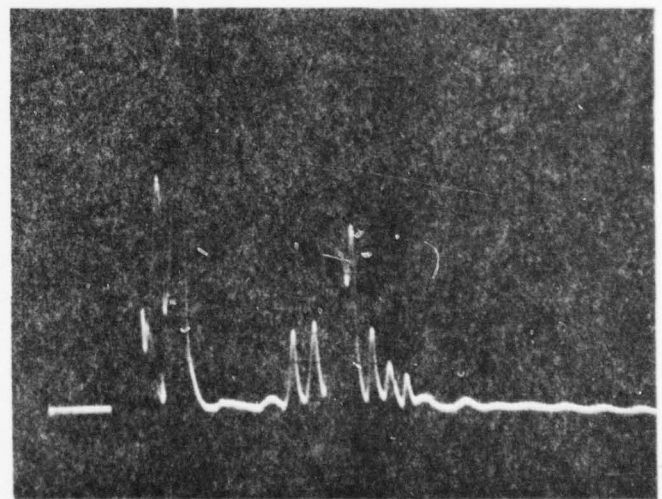

FIGURE A-15: SCOPE DISPLAY OF DEFECT IN AREA 4

Naval Air Systems Command Washington, DC 20360 Attn: AIR-50174	(2 Cys)	Naval Postgraduate School Monterey, CA 95940 Attn: Prof. R. Ball	(1 Cy)
Naval Air Systems Command Washington, DC 20360 Attn: AIR-530	(2 Cys)	Naval Postgraduate School Monterey, CA 95940 Attn: Prof. M. H. Bank	(1 Cy)
Naval Air Systems Command Washington, DC 20360 Attn: AIR-320B	(1 Cy)	Air Force Office of Scientific Research Washington, DC 20333 Attn: Mr. J. Pomerantz	(1 Cy)
Naval Air Systems Command Washington, DC 20360 Attn: AIR-52032D	(1 Cy)	Air Force Materials Lab Wright-Patterson AFB, OH 45433 Attn: LAM (Tech. Library)	(1 Cy)
Naval Air Systems Command Washington, DC 20360 Attn: AIR-5302	(1 Cy)	Air Force Materials Lab Wright-Patterson AFB, OH 45433 Attn: LT-1/Mr. W. Johnston	(1 Cy)
Naval Air Systems Command Washington, DC 20360 Attn: AIR-53021	(1 Cy)	Air Force Materials Lab Wright-Patterson AFB, OH 45433 Attn: LTF/Mr. T. Cordell	(1 Cy)
Naval Air Systems Command Washington, DC 20360 Attn: AIR-530215	(1 Cy)	Air Force Materials Lab Wright-Patterson AFB, OH 45433 Attn: FBSC/Mr. L. Kelly	(1 Cy)
Naval Sea Systems Command Washington, DC 20362 Attn: Code 035, Mr. C. Pohler	(1 Cy)	Air Force Materials Lab Wright-Patterson AFB, OH 45433 Attn: MAC/Mr. G. Peterson	(1 Cy)
Naval Ship Engineering Center Hyattsville, MD 20782 Attn: Code 6101E03 Mr. W. Graner	(1 Cy)	Air Force Materials Lab Wright-Patterson AFB, OH 45433 Attn: MXA/Mr. F. Fecek	(1 Cy)
Office of Naval Research Washington, DC 20362 Attn: Dr. N. Perrone	(1 Cy)	Air Force Materials Lab Wright-Patterson AFB, OH 45433 Attn: MBC/Mr. T. Reinhard, Jr.	(1 Cy)
Naval Ship R&D Center Bethesda, MD 20034 Attn: Code 173.2, Mr. W. Cauch	(1 Cy)	Air Force Flight Dynamics Lab Wright-Patterson AFB, OH 45433 Attn: FB/Mr. P. Parmley	(2 Cys)
Naval Ship R&D Center Annapolis, MD 21402 Attn: Code 2870 Mr. H. Edelstein	(1 Cy)	Air Force Flight Dynamics Lab Wright-Patterson AFB, OH 45433 Attn: FBC/Mr. C. Wallace	(1 Cy)
Naval Ordnance Lab White Oak, MD 20910 Attn: Mr. F. R. Barnet	(1 Cy)	Air Force Flight Dynamics Lab Wright-Patterson AFB, OH 45433 Attn: FBC/Mr. E. Zink	(1 Cy)
Naval Research Lab Washington, DC 20375 Attn: Dr. I. Wolock	(1 Cy)	U.S. Army Materials Command Research Division Washington, DC 20315 Attn: Mr. D. J. Jones	(1 Cy)

U.S. Army Materials Research Agency
Watertown, MA
Attn: Dr. E. Lenoe (1 Cy)

U.S. Army Research Office
Durham, NC 27701

U.S. Army Aviation Materials Lab
Fort Eustis, VA 23603
Attn: Mr. R. Beresford (1 Cy)

Plastics Tech. Evaluation Center
Picatinny Arsenal
Dover, NJ 07801
Attn: Librarian, Bldg. 176
SARPA-FR-M-D (1 Cy)

Plastics Tech. Evaluation Center
Picatinny Arsenal
Dover, NJ 07801
Attn: Mr. H. Peibly (1 Cy)

National Aeronautics & Space Adm.
(ADM)
Washington, DC 20546
Attn: Secretary

Scientific & Tech. Information Facility
College Park, MD
Attn: NASA Representative (1 Cy)

National Aeronautics & Space Adm.
Langley Research Center
Hampton, VA 23365
Attn: Mr. J. P. Peterson (1 Cy)

National Aeronautics & Space Adm.
Langley Research Center
Hampton, VA 23365
Attn: Mr. R. Pride (1 Cy)

National Aeronautics & Space Adm.
Langley Research Center
Hampton, VA 23365
Attn: Mr. M. Card (1 Cy)

National Aeronautics & Space Adm.
Lewis Research Center
Cleveland, OH 44153
Attn: Technical Library (1 Cy)

National Aeronautics & Space Adm.
George C. Marshall Space Flt. Center
Huntsville, AL 35812
Attn: Mr. A. Wilson (1 Cy)

National Aeronautics & Space Adm.
George C. Marshall Space Flt. Center
Huntsville, AL 35812
Attn: S & E-ASTN-ES
Mr. E. E. Engler (1 Cy)

National Aeronautics & Space Adm.
George C. Marshall Space Flt. Center
Huntsville, AL 35812
Attn: S & E-ASTN-M
Mr. R. Schwinghamer (1 Cy)

National Aeronautics & Space Adm.
George C. Marshall Space Flt. Center
Huntsville, AL 35812
Attn: S & E-ASTM-MNM
Dr. J. M. Stuckey (1 Cy)

Defense Documentation Center
Cameron Station
Alexandria, VA 22314 (12 Cys)

Federal Aviation Administration
Airframes Branch, FS-120
Washington, DC 20553
Attn: Mr. J. Dougherty

Avco
Aero Structures Division
Nashville, TN 37202
Attn: Mr. W. Ottenville (1 Cy)

Avco
Space Systems Division
Lowell, MA 01851
Attn: Dr. M. J. Salkind (1 Cy)

Bell Aerospace Company
Buffalo, NY 14240
Attn: Zone I-85, Mr. F. Anthony (1 Cy)

Bell Helicopter Company
Fort Worth, TX 76100
Attn: Mr. Charles Harvey (1 Cy)

Bendix Products
Aerospace Division
South Bend, IN 46619
Attn: Mr. R. V. Cervelli (1 Cy)

Boeing Company
Seattle, WA 98124
Attn: Code 206, Mr. R. Horton (1 Cy)

Boeing Company
Renton, WA 98055
Attn: Dr. R. June (1 Cy)

Boeing Company Vertol Division Philadelphia, PA 19142 Attn: Mr. R. Pinckney	(1 Cy)	General Electric Company Philadelphia, PA 19101 Attn: Mr. L. McCreight	(1 Cy)
Boeing Company Vertol Division Philadelphia, PA 19142 Attn: Mr. D. Hoffstedt	(1 Cy)	Great Lakes Carbon Corporation New York, NY 10017 Attn: Mr. W. Benn, Mgr. Markey Development	(1 Cy)
Boeing Company Wichita, KS 67210 Attn: Mr. V. Reneau/MS 16-39	(1 Cy)	Grumman Aerospace Corporation Bethpage, L.I., NY 11714 Attn: Mr. R. Hadcock	(1 Cy)
Cabot Corporation Billerica Research Center Billerica, MA 01821	(1 Cy)	Grumman Aerospace Corporation Bethpage, L.I., NY 11714 Attn: Mr. S. Dastin	(1 Cy)
Drexel University Philadelphia, PA 19104 Attn: Dr. P. C. Chou	(1 Cy)	Hercules Powder Company, Inc. Cumberland, MD 21501 Attn: Mr. D. Hug	(1 Cy)
E. I. DuPont Company Wilmington, DE 19898 Attn: Dr. Carl Zweben Bldg. 262/Room 316	(1 Cy)	H. I. Thompson Fiber Glass Company Gardena, CA 90249 Attn: Mr. N. Myers	(1 Cy)
Fairchild Industries Hagerstown, MD 21740 Attn: Mr. D. Ruck	(1 Cy)	ITT Research Institute Chicago, IL 60616 Attn: Dr. R. Cornish	(1 Cy)
Ferro Corporation Huntington Beach, CA 92646 Attn: Mr. J. L. Bauer	(1 Cy)	J. P. Stevens & Co., Inc. New York, NY 10036 Attn: Mr. H. Shullock	(1 Cy)
Georgia Institute of Technology Atlanta, GA Attn: Prof. W. H. Horton	(1 Cy)	Kaman Aircraft Corporation Bloomfield, CT 06002 Attn: Technical Library	(1 Cy)
General Dynamics Convair San Diego, CA 92138 Attn: Mr. D. Dunbar	(1 Cy)	Lehigh University Bethlehem, PA 18015 Attn: Dr. G. C. Sih	(1 Cy)
General Dynamics Convair San Diego, CA 92138 Attn: Mr. W. Scheck	(1 Cy)	Lockheed-California Company Burbank, CA 91520 Attn: Mr. E. K. Walker	(1 Cy)
General Dynamics Fort Worth, TX 76101 Attn: Mr. P. Shockey Dept. 23, Mail Zone P-46	(1 Cy)	Lockheed-California Company Burbank, CA 91520 Attn: R. L. Vaughn	(1 Cy)
		Lockheed-Georgia Company Marietta, GA Attn: Adv. Composites Info. Center Dept. 72-14, Zone 42	(1 Cy)

Vought Corporation P.O. Box 5907 Dallas, TX 75222 Attn: Mr. O. E. Dhonau 2-53443	(1 Cy)	Rockwell International Columbus, OH 43216 Attn: Mr. O. G. Acker	(1 Cy)
Vought Corporation P.O. Box 5907 Dallas, TX 75222 Attn: Mr. C. R. Foreman 2-57110	(1 Cy)	Rockwell International Columbus, OH 43216 Attn: Mr. K. Clayton	(1 Cy)
Martin Company Baltimore, MD 21203 Attn: Mr. J. E. Pawken	(1 Cy)	Rockwell International Tulsa, OK 74151 Attn: Mr. E. Sanders	(1 Cy)
Materials Sciences Corporation Blue Bell, PA 19422	(1 Cy)	Rockwell International Tulsa, OK 74151 Attn: Mr. J. H. Powell	(1 Cy)
McDonnell Douglas Corporation St. Louis, MO 63166 Attn: Mr. R. C. Goran	(1 Cy)	Owens Corning Fiberglass Granville, OH 43023 Attn: Mr. D. Mettes	(1 Cy)
McDonnell Douglas Corporation St. Louis, MO 63166 Attn: Mr. O. B. McBee	(1 Cy)	Rohr Corporation Riverside, CA 92503 Attn: Dr. F. Riel	(1 Cy)
McDonnell Douglas Corporation St. Louis, MO 63166 Attn: Mr. C. Stenberg	(1 Cy)	Rohr Corporation Riverside, CA 92503 Attn: Mr. R. Elkin	(1 Cy)
McDonnell Douglas Corporation Long Beach, CA 90801 Attn: Mr. H. C. Schjelderup	(1 Cy)	Ryan Aeronautical Company San Diego, CA 92112 Attn: Mr. R. Long	(1 Cy)
McDonnell Douglas Corporation Long Beach, CA 90801 Attn: Mr. G. Lehman	(1 Cy)	Sikorsky Aircraft Stratford, CT 06497 Attn: Mr. J. Ray	(1 Cy)
Minnesota Mining & Manufacturing Co. St. Paul, MN 55104 Attn: Mr. W. Davis	(1 Cy)	Southwest Research Institute San Antonio, TX 78206 Attn: Mr. G. C. Grimes	(1 Cy)
Northrop Aircraft Corporation Norair Division Hawthorne, CA 90250 Attn: Mr. R. D. Hayes	(1 Cy)	University of Oklahoma Norman, OK 93069 Attn: Dr. G. M. Nordby	(1 Cy)
Northrop Aircraft Corporation Norair Division Hawthorne, CA 90250 Attn: Mr. J. V. Noyes	(1 Cy)	Union Carbide Corporation Cleveland, OH 44101 Attn: Dr. H. F. Volk	(1 Cy)
Northrop Aircraft Corporation Norair Division Hawthorne, CA 90250 Attn: Mr. P. E. Lee	(1 Cy)		

