

AD-A031 077

ARMY ENGINEER DIV NORTH PACIFIC BONNEVILLE OREG DIV --ETC F/G 13/12  
FISH LADDERS FOR LITTLE GOOSE AND LOWER GRANITE DAMS, SNAKE RIV--ETC(U)  
OCT 76 L Z PERKINS

UNCLASSIFIED

TR-129-1

NL

1 OF 1  
AD  
A031077

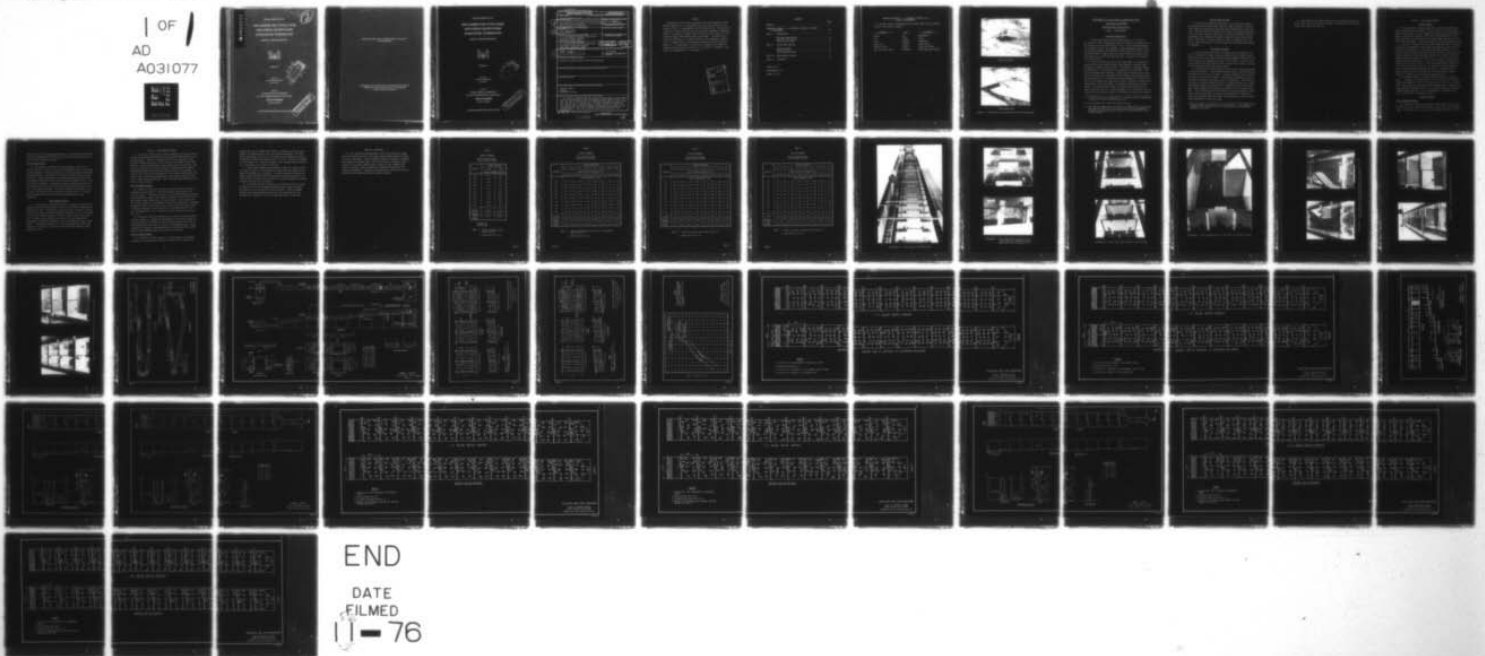

END

DATE  
FILMED  
11-76

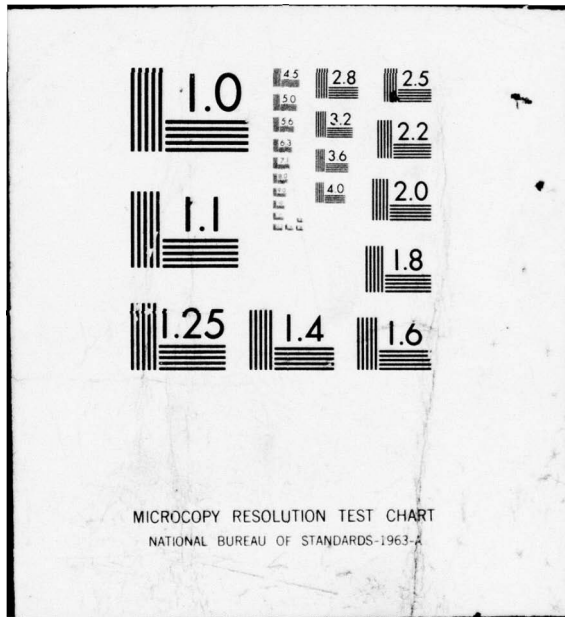

AD A031077

TECHNICAL REPORT NO. 129-1

1-22  
②

FISH LADDERS FOR LITTLE GOOSE  
AND LOWER GRANITE DAMS  
SNAKE RIVER, WASHINGTON

HYDRAULIC MODEL INVESTIGATION



OCTOBER 1976

SPONSORED BY  
U.S. ARMY ENGINEER DISTRICT  
WALLA WALLA

CONDUCTED BY  
DIVISION HYDRAULIC LABORATORY  
U.S. ARMY ENGINEER DIVISION, NORTH PACIFIC  
CORPS OF ENGINEERS  
BONNEVILLE, OREGON

D D C  
RECEIVED  
OCT 21 1976  
R. G. LUTS

THIS DOCUMENT HAS BEEN APPROVED FOR PUBLIC RELEASE

DISTRIBUTION STATEMENT A  
Approved for public release  
Distribution Unlimited

Destroy this report when no longer needed. Do not return  
it to the originator.

The findings in this report are not to be construed as an official  
Department of the Army position unless so designated  
by other authorized documents.

TECHNICAL REPORT NO. 129-1

**FISH LADDERS FOR LITTLE GOOSE  
AND LOWER GRANITE DAMS  
SNAKE RIVER, WASHINGTON**

HYDRAULIC MODEL INVESTIGATION

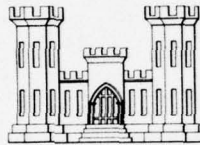

OCTOBER 1976

SPONSORED BY  
U.S. ARMY ENGINEER DISTRICT  
WALLA WALLA

CONDUCTED BY  
DIVISION HYDRAULIC LABORATORY  
U.S. ARMY ENGINEER DIVISION, NORTH PACIFIC  
**CORPS OF ENGINEERS**  
BONNEVILLE, OREGON

THIS DOCUMENT HAS BEEN APPROVED FOR PUBLIC RELEASE

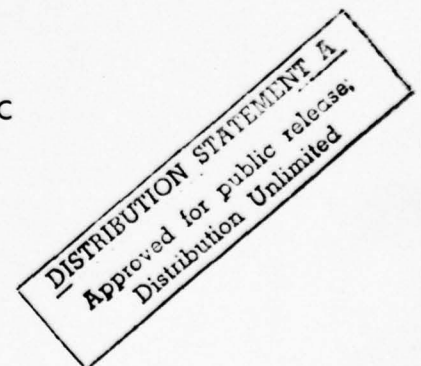

Unclassified

SECURITY CLASSIFICATION OF THIS PAGE (When Data Entered)

REPORT DOCUMENTATION PAGE		READ INSTRUCTIONS BEFORE COMPLETING FORM
1. REPORT NUMBER Technical Report No. 129-1	2. JOVT ACCESSION NO.	3. RECIPIENT'S CATALOG NUMBER
4. TITLE (and Subtitle) 6 Fish Ladders For Little Goose And Lower Granite Dams, Snake River, Washington, Hydraulic Model Investigations.		5. TYPE OF REPORT & PERIOD COVERED 9 Final Report.
7. AUTHOR(s) 10 Louis Z. Perkins		6. PERFORMING ORG. REPORT NUMBER
9. PERFORMING ORGANIZATION NAME AND ADDRESS U. S. Army Engineer Division, North Pacific Division Hydraulic Laboratory Bonneville, Oregon 97008		8. CONTRACT OR GRANT NUMBER(s)
11. CONTROLLING OFFICE NAME AND ADDRESS U. S. Army Engineer District, Walla Walla Building 602, City-County Airport Walla Walla, Washington 99362	12. REPORT DATE 11 October 1976	10. PROGRAM ELEMENT, PROJECT, TASK AREA & WORK UNIT NUMBERS 12 42p.
14. MONITORING AGENCY NAME & ADDRESS (if different from Controlling Office) 14 TR-129-1	13. NUMBER OF PAGES 37	15. SECURITY CLASS. (of this report) Unclassified
16. DISTRIBUTION STATEMENT (of this Report) Approved for public release; distribution unlimited.		
17. DISTRIBUTION STATEMENT (of the abstract entered in Block 20, if different from Report)		
18. SUPPLEMENTARY NOTES		
19. KEY WORDS (Continue on reverse side if necessary and identify by block number) Hydraulic Models Fishways Regulating Sections		
20. ABSTRACT (Continue on reverse side if necessary and identify by block number) A 1:10-scale hydraulic model was used to develop designs for the overflow section, weir upstream from the fish counting station, orifice control section, and exit of a 20-ft-wide, 1V on 10H-slope fish ladder for Little Goose Dam. Data from this study were used to design a similar fish ladder for Lower Granite Dam. An improved type of control section with vertical slots and submerged orifices in the bulkheads was developed in the model for use at Lower Granite. This type of control section was installed at both projects.		

DD FORM 1 JAN 73 1473 EDITION OF 1 NOV 65 IS OBSOLETE

Unclassified  
SECURITY CLASSIFICATION OF THIS PAGE (When Data Entered)

408953

YB

PREFACE

The hydraulic model studies described herein were authorized by the Division Engineer, U. S. Army Engineer Division, North Pacific, at the request of the U. S. Army Engineer District, Walla Walla. The tests were conducted at the North Pacific Division Hydraulic Laboratory, Bonneville, Oregon, from February to August 1964 (Little Goose fish ladder) and from January to August 1966 (Lower Granite fish ladder). The studies were supervised by Messrs. H. P. Theus, Director of the Laboratory (retired), and A. J. Chanda, Head of the Laboratory Hydraulics Section (retired). Messrs. R. L. Johnson and P. M. Smith were in charge of the respective studies and were assisted by Messrs. D. E. Fox and G. D. Bocksler. This report was compiled by Mr. L. Z. Perkins.

ACCESSION for	
NTIS	White Section <input checked="" type="checkbox"/>
DGC	Buff Section <input type="checkbox"/>
UNANNOUNCED	
JUSTIFICATION	
BY	
DISTRIBUTION AVAILABILITY CODES	
Dist.	AVAIL. an/or Special
A	

CONTENTS

	Page
PREFACE . . . . .	i
CONVERSION FACTORS, U. S. CUSTOMARY TO METRIC (SI) UNITS OF MEASUREMENT . . . . .	iii
PART I: INTRODUCTION . . . . .	1
Prototype Descriptions . . . . .	1
Need for Model Studies . . . . .	2
Description of Model . . . . .	2
PART II: LITTLE GOOSE STUDIES . . . . .	4
Overflow Section . . . . .	4
Control Section . . . . .	4
Fish Counting Station . . . . .	5
PART III: LOWER GRANITE STUDIES . . . . .	6
PART IV: DISCUSSION . . . . .	8

TABLES A TO D

PHOTOGRAPHS 1 TO 7

PLATES 1 TO 14

CONVERSION FACTORS, U. S. CUSTOMARY TO METRIC (SI)  
UNITS OF MEASUREMENT

U. S. customary units of measurement used in this report can be converted to metric (SI) units as follows:

<u>Multiply</u>	<u>By</u>	<u>To Obtain</u>
inches	2.54	centimeters
feet	0.3048	meters
miles	1.609344	kilometers
square feet	0.092903	square meters
feet per second	0.3048	meters per second
cubic feet per second	0.0283168	cubic meters per second

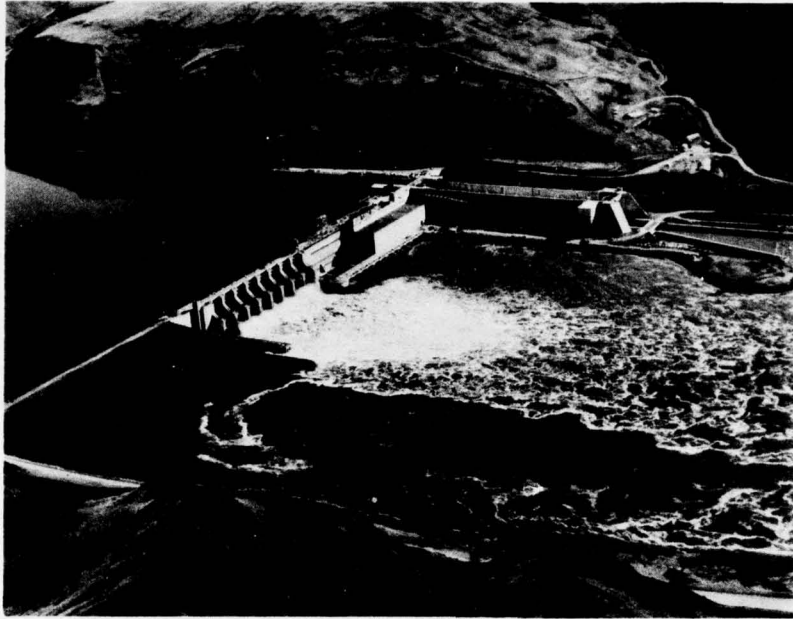

Little Goose Dam



Lower Granite Dam

Figure 1. Aerial views of Little Goose and Lower Granite Dams.

FISH LADDERS FOR LITTLE GOOSE AND LOWER GRANITE DAMS

SNAKE RIVER, WASHINGTON

Hydraulic Model Investigations

PART I: INTRODUCTION

Prototype Descriptions

1. Little Goose and Lower Granite Dams (figure 1) are located 70.3 and 107.5 miles, respectively, above the mouth of the Snake River.\* The projects have been constructed by the U. S. Army Corps of Engineers for navigation, power, and recreation. Normal operating forebay levels vary between elevations 633 and 638 at Little Goose and from 733 to 738 at Lower Granite.\*\* Each project has one 20-ft-wide fish ladder with a floor slope of 1V on 10H and identical weirs. Outlines of the ladders are shown on plate 1.

2. Flow in the upper portion of each fish ladder is regulated by a control section and diffusion chamber that maintain a constant ladder discharge as forebay elevations vary. The quantity of discharge depends on the pattern of flow selected for standard pools in the ladder. The diffusion chambers were designed to supply about 10 percent of the total flow in the portions of the ladders above tailwater with maximum forebay elevations and up to 75 percent with minimum elevations.\*\*\* Earlier projects on the Columbia and Snake Rivers utilize a series of orifices at the upstream end of the fish ladders to accommodate fluctuations in forebay levels. An orifice control section for Little Goose fish ladder was model-tested (see PART II). After development of an orifice-slot control section for Lower Granite (PART III) the design was used at both projects.

---

\* A table of factors for converting U. S. customary units of measurement to metric (SI) units is shown on page iii.

\*\* All elevations are in feet above mean sea level.

\*\*\* Flow down the ladders and from diffusion chambers (plate 1) will maintain required velocities of 2 fps over weirs that are submerged by tailwater and provide adequate quantities of attraction flow at the fishway entrances.

### Need for Model Studies

3. The layout and operating conditions of fish facilities proposed for Little Goose and Lower Granite Dams were almost identical to those in fish ladders previously model-tested and under construction at other projects. However, experience indicated that reducing the ladder width from 24 to 20 ft would require a model study to insure satisfactory hydraulic performance and to determine discharge ratings for various heads on the weirs. Model tests of control sections of both fish ladders were necessary to check performance of initial designs and to develop modifications if necessary.

### Description of Model

4. The 1:10-scale Little Goose fish ladder model (photograph 1 and plate 2) included a straight, 36-pool overflow section of ladder between weirs 591 and 627,\* the control section between bulkheads 628 and 637, the exit section, and an appropriate portion of the forebay. Following tests of the typical weirs and control section, the model was revised to include the fish counting station and adjacent weirs.

5. Water used in the model was recirculated from a large sump through a system of pipelines. A rock-filled baffle was used to establish uniform distribution of flow into the model. Tailwater elevations were controlled by means of an adjustable tailgate. Water-surface elevations were measured with staff gages, point gages, and water manometers. Velocities were measured in a horizontal plane by means of a midget current meter. Diffusion chamber inflows were measured by a calibrated orifice in the supply pipe; total discharge in the ladder was measured over a 90-degree V-notch weir. Pools between weirs 614 and 616 were used as typical pools in which heads, current directions, and velocities were measured. Equations of hydraulic similitude based on Froudian relationships were used to transfer model measurements to prototype terms.

---

\* The weir numbers correspond to the crest elevations. The designation of bulkheads in the control section is a continuation of the numbering sequence of the weirs.

6. That portion of the model upstream from the diffusion chamber was used to test orifice-slot control bulkheads 728 through 737 for the Lower Granite fish ladder (see PART III).

## PART II: LITTLE GOOSE STUDIES

### Overflow Section

7. Flow conditions in typical pools 614 and 615 were satisfactory with the initial design condition of 12 in. of head on the weirs (photograph 2 and plate 3). Flow was symmetrical within the pools and down the length of the overflow section. The fins on the upstream faces of the weirs controlled the orifice jets and confined higher velocities to each side of the fish ladder. Velocities through the orifices averaged 9.2 fps.

8. The plan A orifices in weir 627 were larger than those in successive weirs to compensate for lower approach velocities at the top of the overflow section (plate 2). With normal operating conditions of 10 to 12 in. of head on weirs, head on weir 627 was the same as the head on the typical weirs with a given discharge; however, flow from the oversized orifices caused the head on weir 626 to be 1.1 to 1.6 in. greater. The additional head was excessive. The size of the orifices in weir 627 was reduced to 18 by 18 in. (plan B). With the revised design condition of 12-in. head on the plan B weir 627, the head on the typical weirs was 10.8 in., and the ladder discharge was 72.2 cfs. Flow conditions in pools 614 and 615 were also satisfactory with that design condition (plate 4). Velocities at the orifices averaged 8.8 fps.

9. Discharge ratings for weirs 614 and 627 (plan B) are shown on plate 5. Surging to a maximum height of 6 in. occurred in the overflow section with heads of 7 to 10.5 in. on weir 627 (4.7 to 8.9 in. on weir 614). Those heads were below the normal operating range. Plunging flow, characterized by upstream currents at the surface of the pool and downstream currents along the floor, was maintained to a maximum head of 13.9 on weir 614 and a discharge of 80.0 cfs.

### Control Section

#### Plan A (Original Design)

10. The plan A control section shown in photograph 3 and on plate 2 had two 18- by 37-in. orifices with center lines 3.5 ft from the ladder walls. The orifices were on the floor in bulkheads 628 to 631 and 1.0 ft

above the floor in the remaining bulkheads. The difference in heads that occurred on bulkheads 637 and 636 with the forebay at elev 638 (0.31 ft, table A) were considered excessive.

#### Plan C (Final Design)

11. The orifices in bulkhead 637 were enlarged to 18 by 39 in. (plan B) and then to 18 by 40 in. in the final design (plan C) to improve head distribution. Heads on bulkheads in the plan C control section with forebay elevations 1 ft below to 1 ft above the normal levels are shown in table B. With forebay elev 638, the maximum variation of heads from the average through the control section was plus and minus 0.07 ft. That variation was acceptable. Discharges through the section were 40.0 cfs with forebay elev 633 to 56.6 cfs with forebay elev 638, 55 and 78 percent of the ladder discharge. The higher velocities in the pools, 5.3 to 8.9 fps, were confined to the orifice jets (plates 6 and 7). Flow patterns throughout the control section were satisfactory for both conditions.

#### Fish Counting Station

12. Studies of the fish counting station, located in a level section between weirs 563 and 564 (plates 1 and 8), were limited to checking the design of weir 564. The overflow sections and outer orifices of weir 564 were sized to provide a minimum slide gate opening of 1.0 ft at the center orifice with a ladder discharge of 58.8 cfs (10-in. head on plan B weir 627). Details of weir 564 and that portion of the counting station reproduced are shown in photograph 4. Flow conditions are shown in photograph 5. The design discharge of 58.8 cfs was passed with a slide gate opening of 1.03 ft; 72.2 cfs (12-in. head on weir 627) required a gate opening of 1.43 ft.

### PART III: LOWER GRANITE STUDIES

13. The plan C orifice control section developed in the Little Goose studies was satisfactory hydraulically and could have been adapted for use at Lower Granite. However, some species of fish are reluctant to move upstream through this type of control section at Ice Harbor Dam and other projects. Large concentrations of fish, mainly scrap fish and shad, sometimes occur in pools of the orifice control sections but not in ladder pools which provide both overflow and orifice flow for fish passage. The orifice-slot control section proposed for Lower Granite would provide both types of flow, reduce the concentration of scrap fish, and speed up passage of salmon and steelhead trout. Few if any shad will migrate upstream as far as Lower Granite.

#### Plan A (Original Design)

14. Details of the plan A orifice-slot control section are shown in photograph 6 and on plate 9. Head and discharge characteristics are listed in table C. Variations with the elev 738 forebay (design condition) were satisfactory; however, the maximum variations of +0.42 ft and -0.25 ft with minimum normal forebay elev 733 were excessive. With forebay elev 738 and 739, control was at bulkheads 735 and 734, respectively. Discharge through the section varied from 30.8 to 63.8 cfs within the normal range of forebay elevations. Those flows were 42.7 and 88.4 percent of the 72.2 cfs required for 12 in. of head on the first overflow section weir (weir 727).

15. Velocities and flow directions in the control section are shown on plates 10 and 11. Although the dissipation of velocities through the slots was adequate, flow from the slots was directed toward the wall in even-numbered pools and toward the center of odd-numbered pools. Better dissipation of energy in odd-numbered pools was indicated by the higher heads on those bulkheads when the forebay was at elev 738.

#### Plan C-5 (Final Design)

16. The plan C-5 control section, the final design, was developed from plan A by experimentally varying the orifice sizes, the slot sill

heights, and the fin lengths and locations to create more nearly uniform heads on the bulkheads and to pass the required discharges. The final design (photograph 7 and plate 12) differed from the original as follows: the height of orifices was reduced from 37 to 24 in., the sill in bulkhead 737 was lowered 6 in., and fins adjacent to the orifices were shortened to 18 in. and placed 15 in. from the orifices.

17. Head on the bulkheads and discharges through the control section are listed in table D. The variations in heads from the average and the range of discharges were acceptable. The small variations in heads with higher forebay elevations and the progressive variation through the control section with lower pools indicated that energy dissipation was nearly uniform in all parts of the section.

18. Velocities and flow directions in the control section are shown on plates 13 and 14 for minimum and maximum normal forebay elevations. Flow patterns in the pools were uniform and stable. Almost straight-through flow occurred between the orifices, and velocities from the upstream slot dissipated in the left downstream corner of each pool.

#### PART IV: DISCUSSION

19. Flow conditions and discharges in the Little Goose fish ladder and in the overflow section of the Lower Granite ladder should be similar to those in the model. Owing to different approach conditions, two bends, and a longer pool between weirs 733 and 734 (plate 1), hydraulic characteristics of the Lower Granite control section may vary somewhat from those in the model. Both prototype fish ladders have been built and operated successfully. Fish have passed through the overflow and control sections of both ladders without any apparent problem.

TABLE A

## HEAD ON BULKHEADS

Plan A Control Section  
Little Goose Fish Ladder

Bulkhead	Forebay Elevation	
	633	638
	Head on Bulkhead in Feet	
628	0.47	1.00
629	0.53	1.07
630	0.46 <sup>1</sup>	1.07
631	0.53	1.03
632	0.49	1.05
633	0.49	0.93
634	0.50	0.96
635	0.50	0.96
636	0.46 <sup>1</sup>	0.84 <sup>1</sup>
637	0.57 <sup>2</sup>	1.15 <sup>2</sup>
Average	0.50	1.00
Maximum Variation from Average	+0.07	+0.15
	-0.04	-0.16

<sup>1</sup> Extreme low

<sup>2</sup> Extreme high

NOTES: 1. Details of control section  
shown on plate 2.

2. Head on weir 627, 12 in.

TABLE A

TABLE B

## HEAD ON BULKHEADS

Plan C Control Section  
Little Goose Fish Ladder

Bulkhead	Forebay Elevation							
	632	633	634	635	636	637	638	639
	Control Section Discharge in CFS							
	36.8	40.0	43.9	47.1	49.9	53.1	56.6	59.1
	Head on Bulkhead in Feet							
628	0.38	0.49	0.58	0.68	0.76	0.87	0.96	1.08
629	0.43	0.54	0.64	0.73	0.84	0.94	1.07	1.14
630	0.39	0.51	0.61	0.70	0.81	0.92	1.07	1.03
631	0.43	0.55	0.67	0.79	0.88	0.98	1.07	1.18
632	0.40	0.51	0.64	0.74	0.85	0.96	1.00	1.10
633	0.40	0.50	0.59	0.68	0.76	0.83	0.96	1.11
634	0.39	0.50	0.57	0.71	0.87	0.98	0.99	1.08
635	0.40	0.50	0.64	0.71	0.79	0.88	0.98	1.08
636	0.38	0.42	0.45	0.55	0.67	0.76	0.93	1.13
637	0.40	0.48	0.61	0.71	0.77	0.88	0.97	1.07
Average	0.40	0.50	0.60	0.70	0.80	0.90	1.00	1.10
Maximum Variation from Average	+0.03	+0.05	+0.07	+0.09	+0.08	+0.08	+0.07	+0.08
	-0.02	-0.08	-0.15	-0.15	-0.13	-0.14	-0.07	-0.07

NOTES: 1. Orifice in bulkhead 637, 18 by 40 in. Other details shown on plate 2.

2. Head on weir 627, 12 in.

TABLE B

TABLE C

## HEAD ON BULKHEADS

Plan A Control Section  
Lower Granite Fish Ladder

Bulkhead	Forebay Elevation							
	732	733	734	735	736	737	738	739
	Control Section Discharge in CFS							
	25.2	30.8	37.1	43.0	49.6	56.2	63.8	70.8
Head on Bulkhead in Feet								
728	0.18	0.25	0.36	0.46	0.57	0.75	0.92	1.11
729	0.19	0.28	0.40	0.54	0.66	0.81	0.95	1.10
730	0.25	0.35	0.47	0.58	0.71	0.86	1.00	1.10
731	0.29	0.42	0.55	0.67	0.78	0.89	0.98	1.12
732	0.36	0.45	0.57	0.68	0.80	0.90	0.99	1.12
733	0.36	0.54	0.64	0.77	0.85	0.93	1.03	1.05
734	0.52	0.57	0.67	0.75	0.84	0.96	0.94	1.17
735	0.56	0.67	0.74	0.82	0.92	0.93	1.12	1.06
736	0.44	0.55	0.63	0.77	0.91	0.97	1.02	1.07
737	0.85	0.92	0.97	0.96	0.96	1.00	1.05	1.10
Average	0.40	0.50	0.60	0.70	0.80	0.90	1.00	1.10
Maximum Variation from Average	+0.45	+0.42	+0.37	+0.26	+0.16	+0.10	+0.12	+0.07
	-0.22	-0.25	-0.24	-0.24	-0.23	-0.15	-0.08	-0.05

- NOTES: 1. Details of control section shown on plate 9.  
2. Head on weir 727, 12 in.

TABLE C

TABLE D

## HEAD ON BULKHEADS

Plan C-5 Control Section  
Lower Granite Fish Ladder

Bulkhead	Forebay Elevation							
	732	733	734	735	736	737	738	739
	Control Section Discharge in CFS							
	18.5	24.4	30.8	36.8	43.6	50.2	57.5	64.5
Head on Bulkhead in Feet								
728	0.14	0.22	0.34	0.48	0.65	0.84	1.06	1.29
729	0.15	0.26	0.37	0.52	0.65	0.82	0.96	1.13
730	0.19	0.30	0.42	0.55	0.74	0.87	0.97	1.07
731	0.23	0.37	0.50	0.63	0.71	0.81	0.93	1.06
732	0.29	0.41	0.54	0.65	0.77	0.86	0.98	1.11
733	0.40	0.54	0.68	0.78	0.88	0.96	1.08	1.17
734	0.47	0.61	0.71	0.79	0.84	0.92	1.00	1.06
735	0.64	0.72	0.78	0.83	0.88	0.97	1.02	1.09
736	0.68	0.73	0.78	0.87	0.95	1.02	1.03	1.07
737	0.81	0.84	0.88	0.90	0.93	0.93	0.97	0.95
Average	0.40	0.50	0.60	0.70	0.80	0.90	1.00	1.10
Maximum Variation from Average	+0.41	+0.34	+0.28	+0.20	+0.15	+0.12	+0.08	+0.19
	-0.26	-0.28	-0.26	-0.22	-0.15	-0.09	-0.07	-0.15

NOTES: 1. Details of control section are shown on plate 12.

2. Head on weir 727, 12 in.

TABLE D

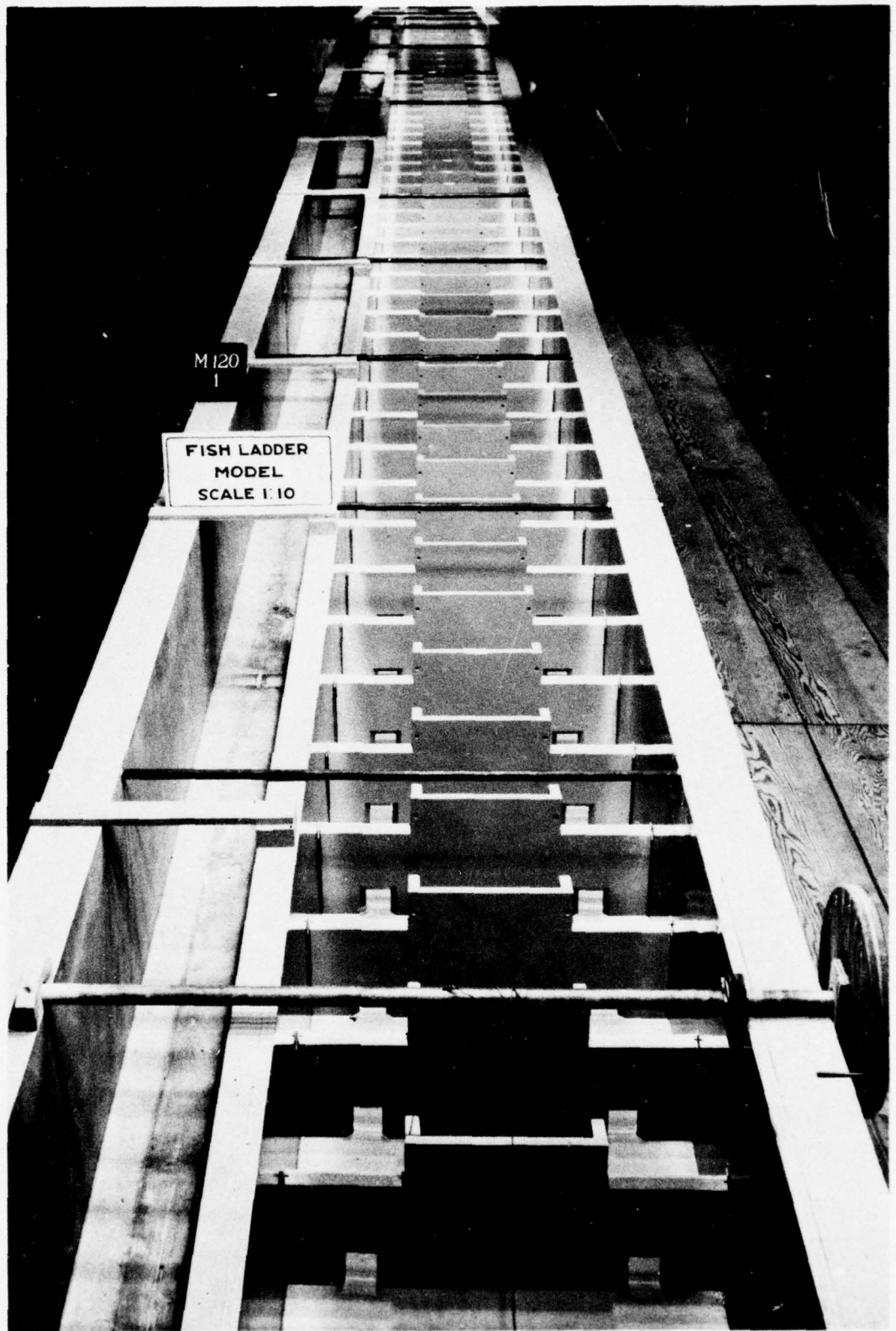

Photograph 1. Little Goose fish ladder model.

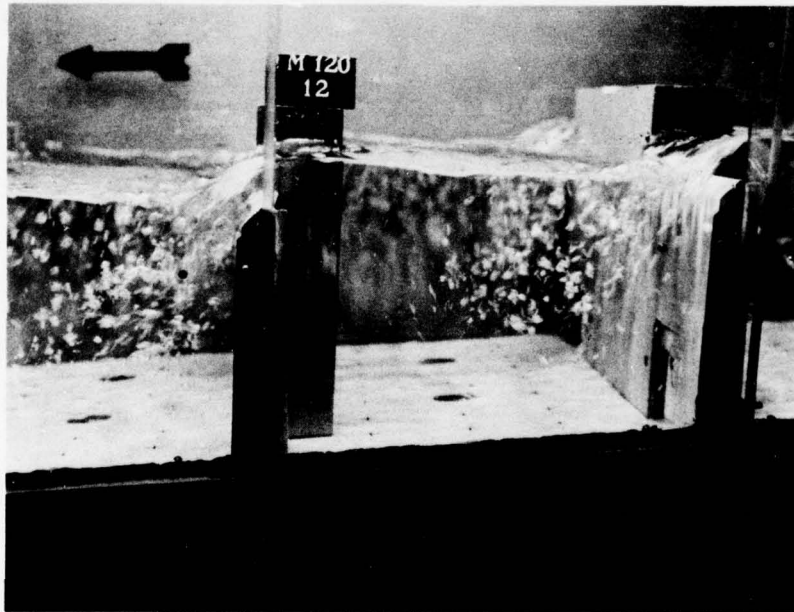
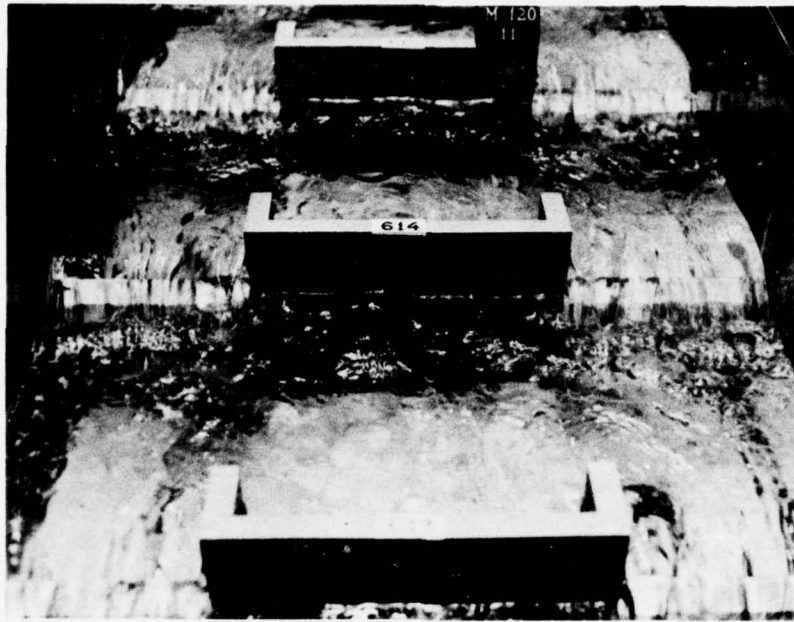

Photograph 2. Flow conditions in typical pools of Little Goose fish ladder with 12-in. head on weir 614; discharge 76 cfs.

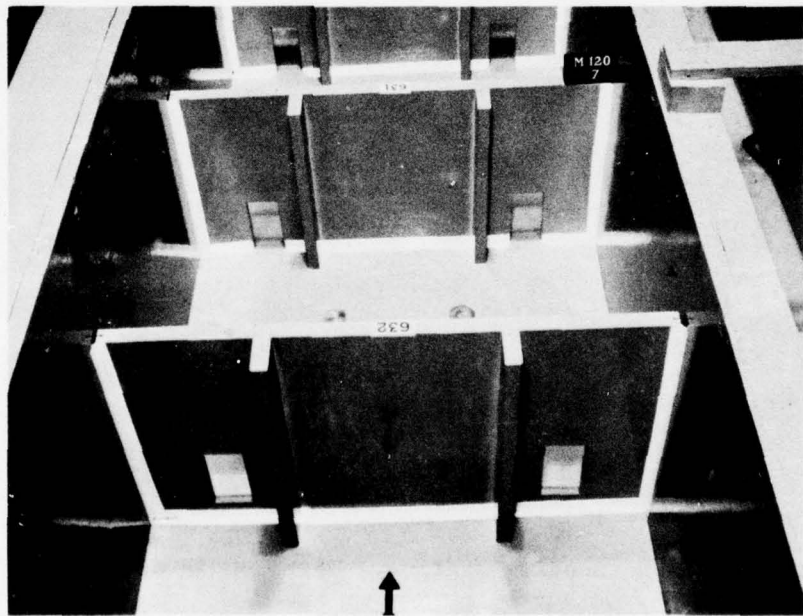
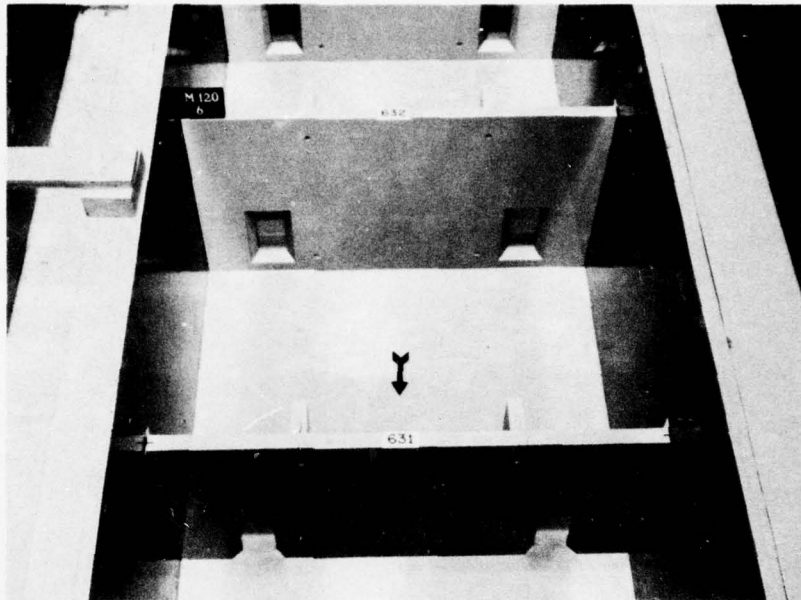

Photograph 3. Plan A Little Goose orifice control section.

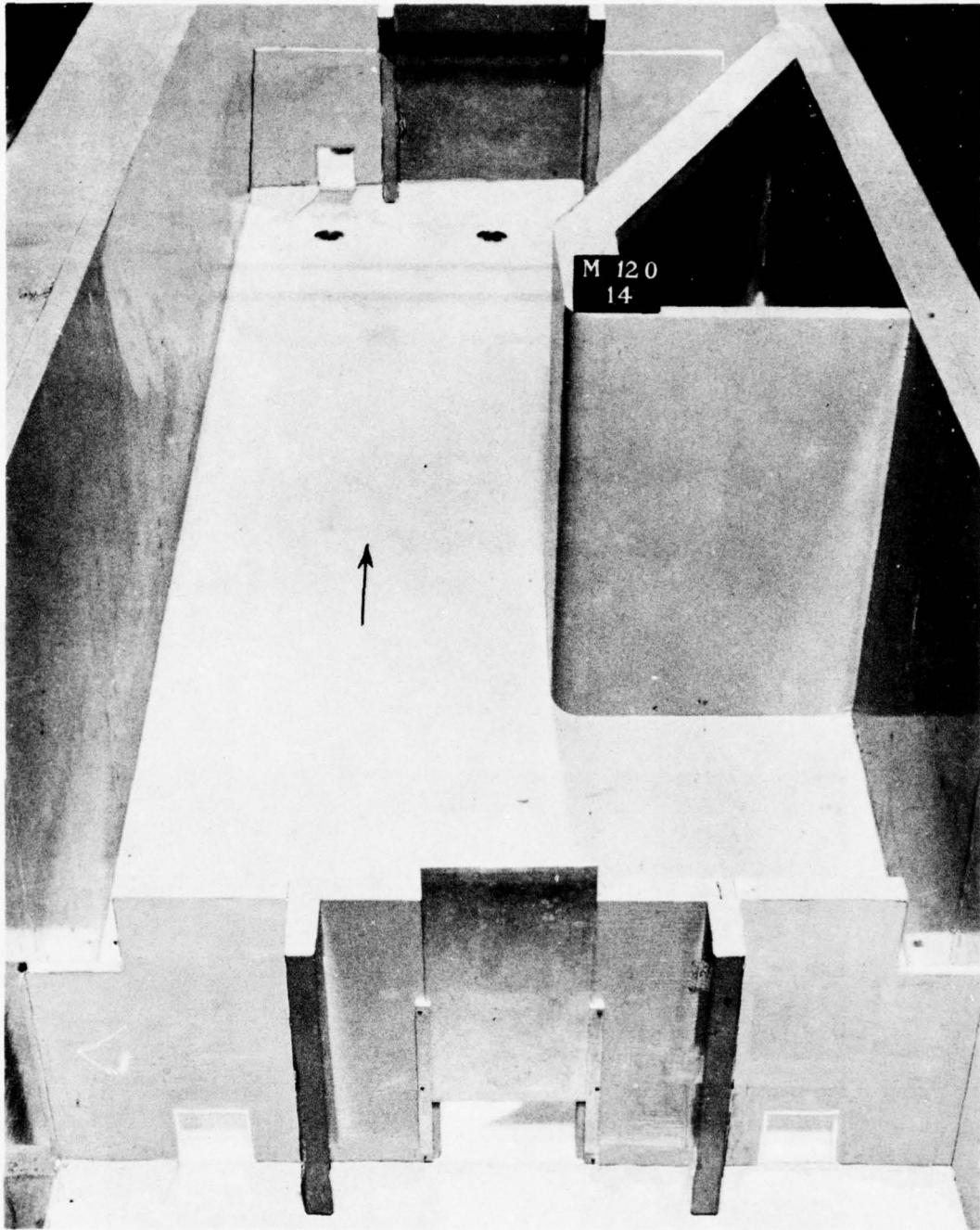

Photograph 4. Fish counting station. Weir 564 is at bottom of picture.

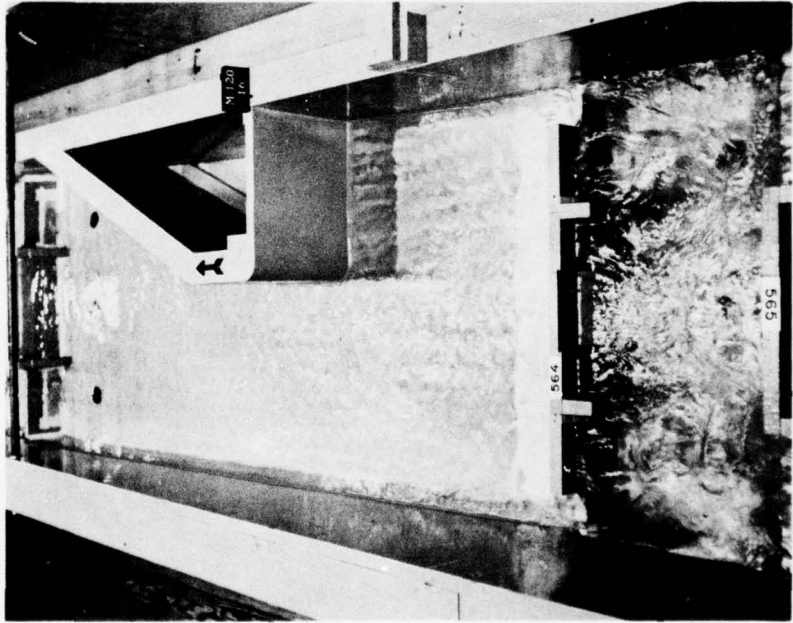
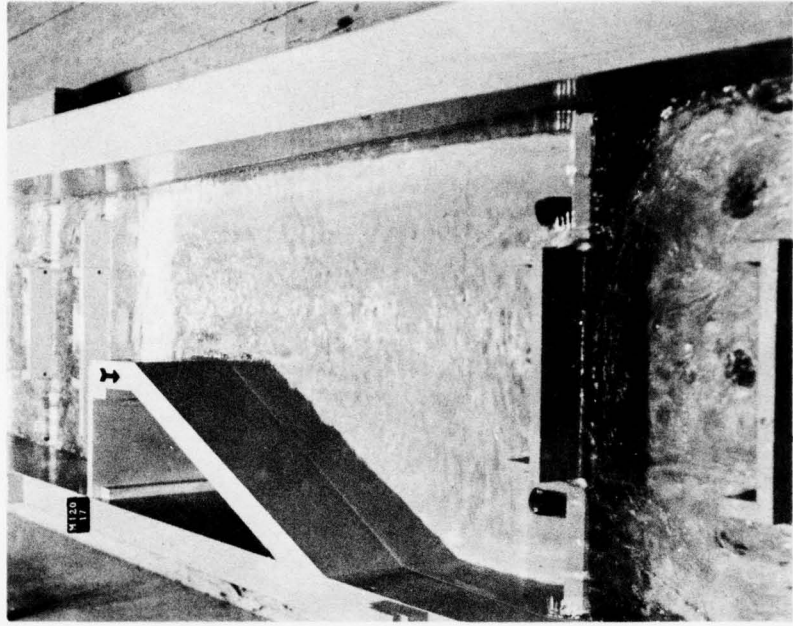

Photograph 5. Flow conditions at fish counting station; 12-in. head on weir 627; discharge 72.2 cfs; slide gate in weir 564 open 1.43 ft.

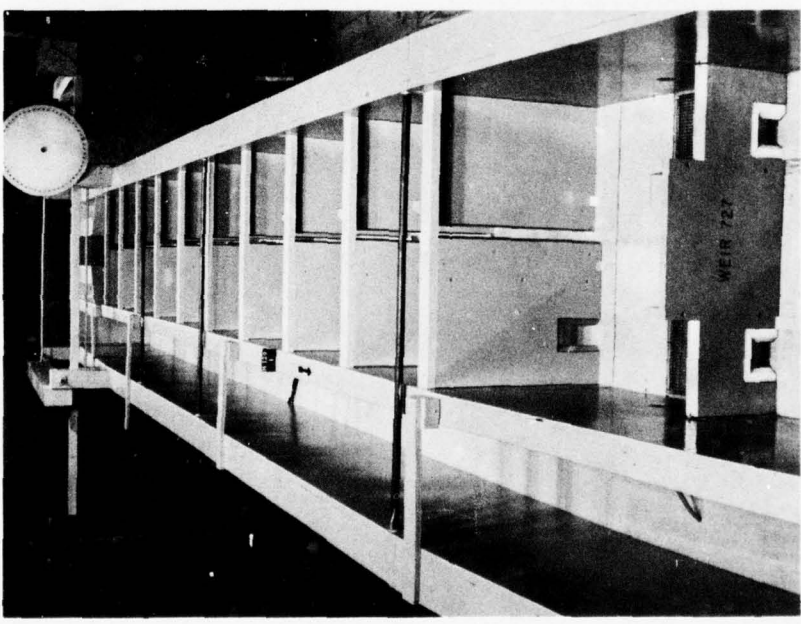
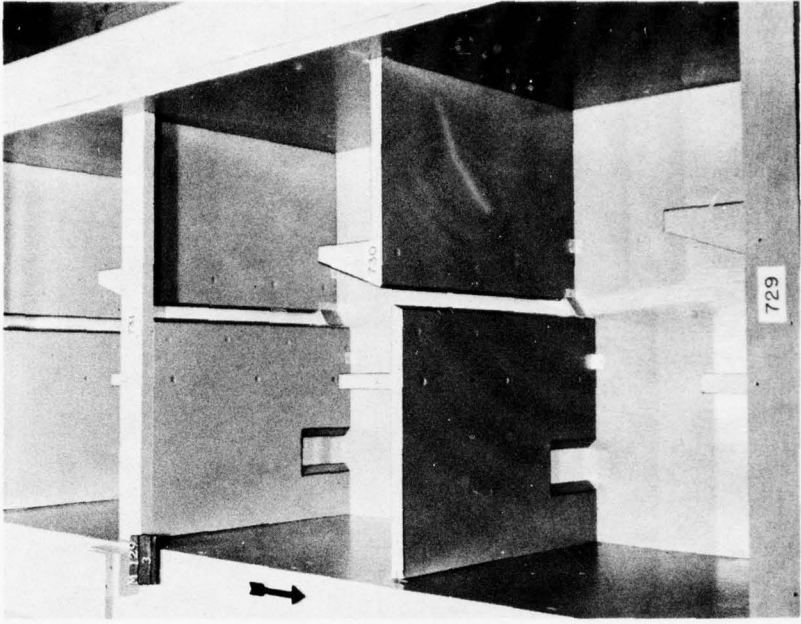

Photograph 6. Plan A Lower Granite control section.

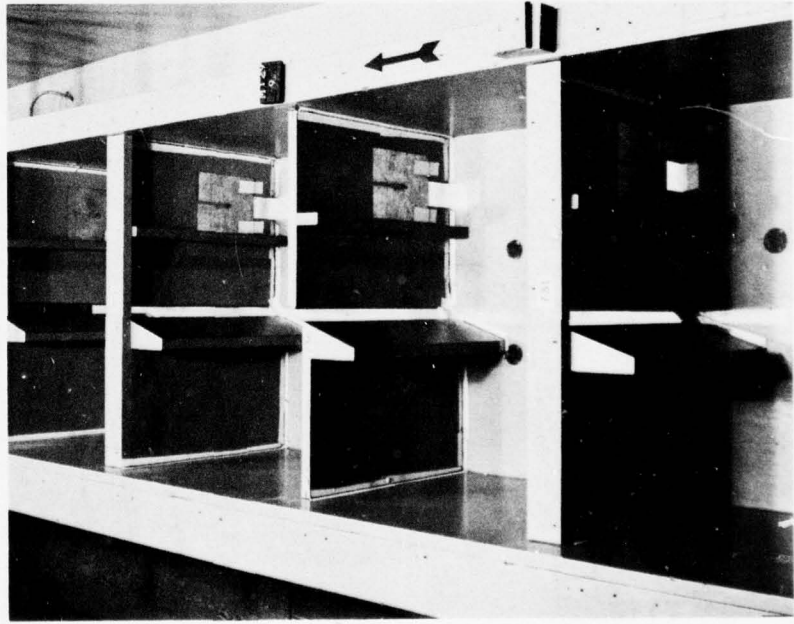
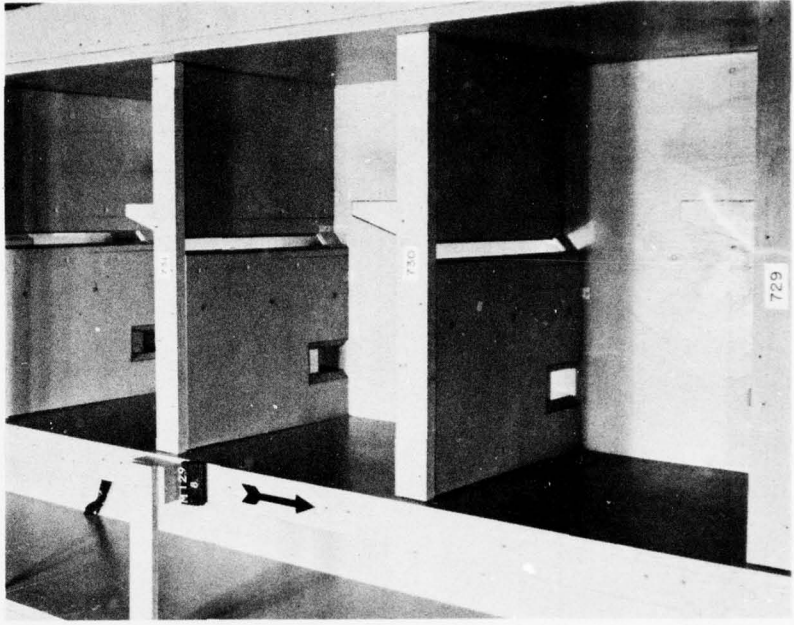

Photograph 7. Plan C-5 Lower Granite control section (final design).

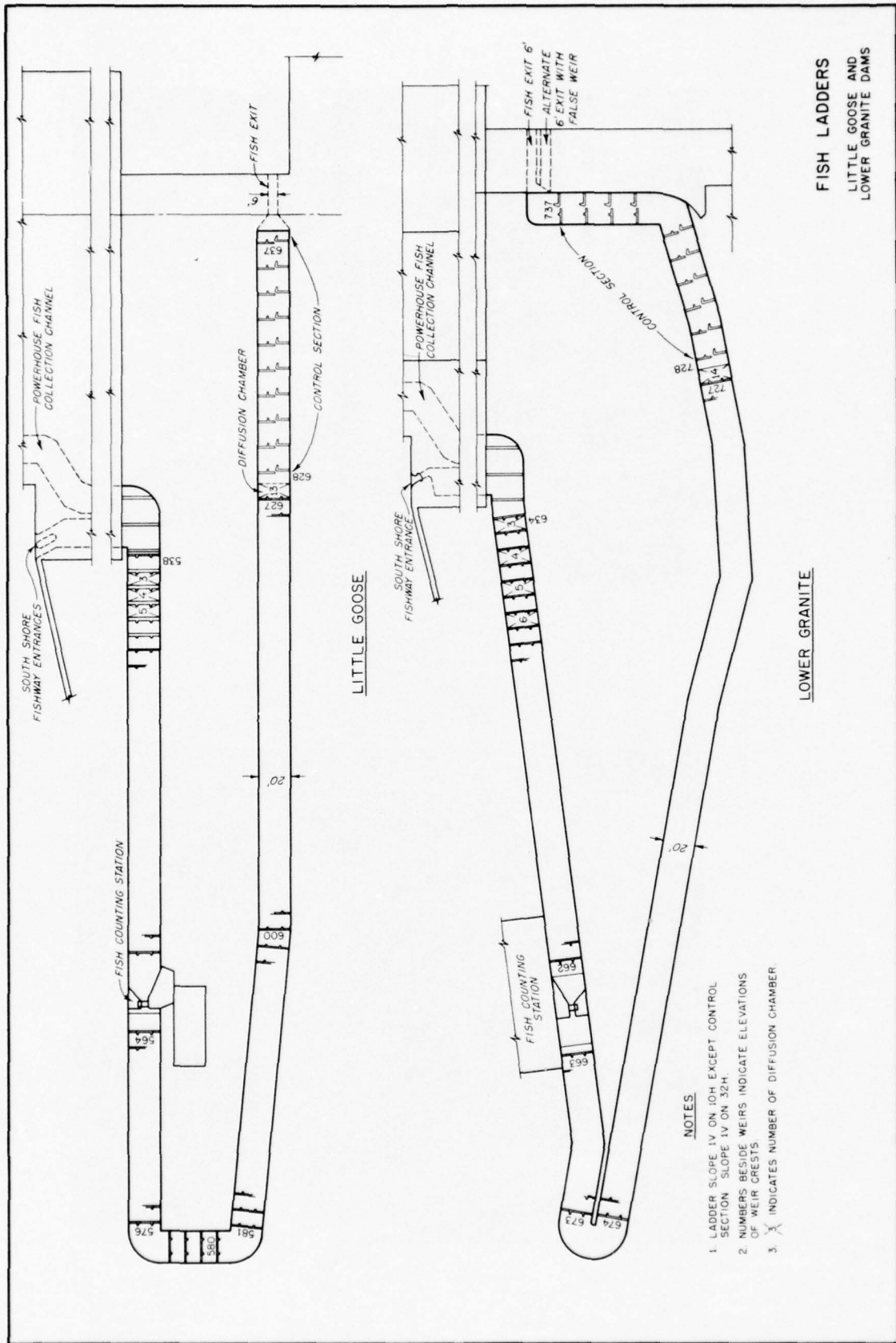

**FISH LADDERS**  
**LITTLE GOOSE AND**  
**LOWER GRANITE DAMS**

- NOTES**
1. LADDER SLOPE 1V ON 10H, EXCEPT CONTROL SECTION SLOPE 1V ON 32H.
  2. NUMBERS BESIDE WEIRS INDICATE ELEVATIONS OF WEIR CRESTS.
  3. X INDICATES NUMBER OF DIFFUSION CHAMBER

PLATE 1

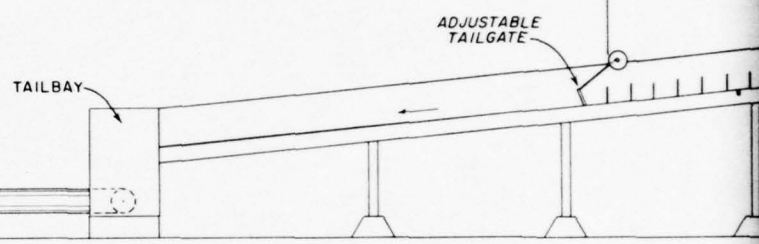
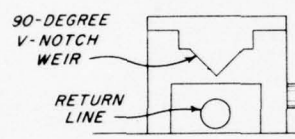
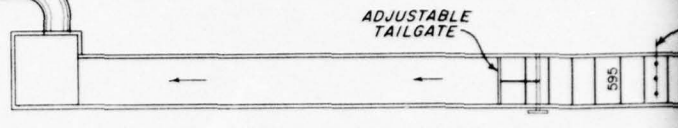
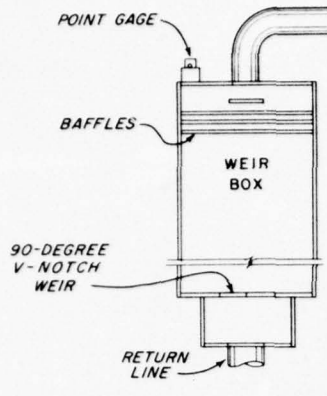

WEIR BOX

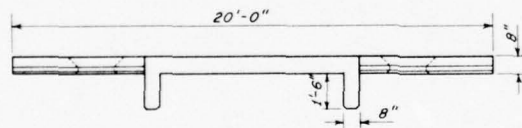

PLAN

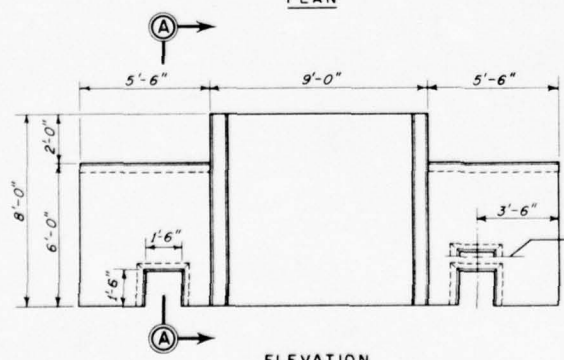

ELEVATION

WEIRS 591 TO 627

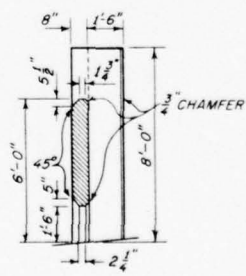

SECTION A-A

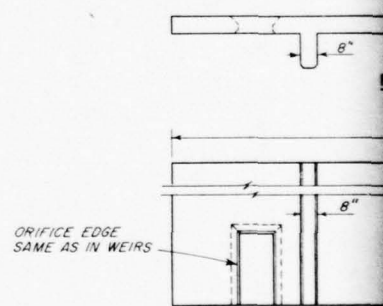

BULKHEADS

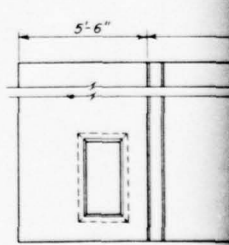

BULKHEADS

EL





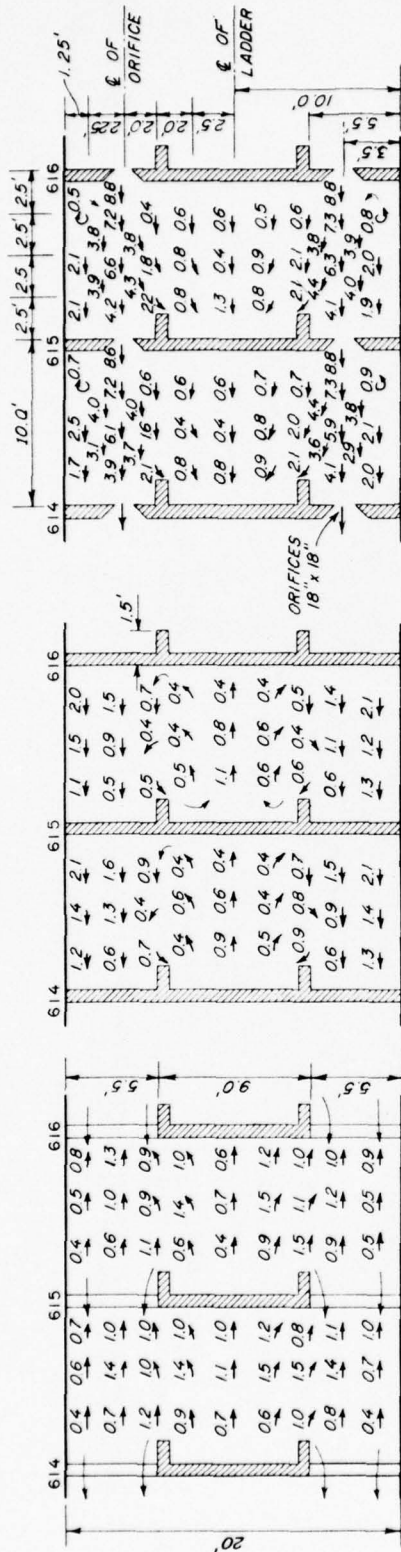

CENTER LINE OF UPSTREAM ORIFICE

MID-DEPTH

TOP OF DOWNSTREAM WEIR

PLANS

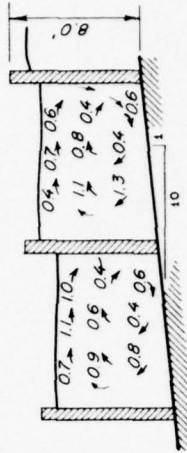

CENTER LINE OF POOLS

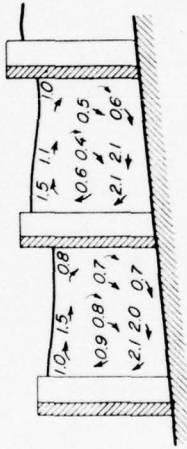

5.5 FT FROM LEFT WALL

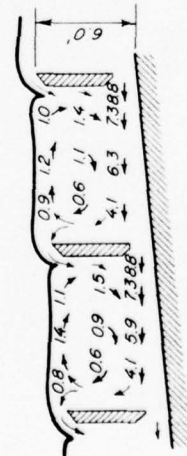

3.5 FT FROM LEFT WALL

ELEVATIONS

NOTES

1. VELOCITIES (FPS) MEASURED IN HORIZONTAL PLANE
2. HEAD DETERMINED FROM WATER-SURFACE ELEVATION 5-FT UPSTREAM FROM WEIR 627.

VELOCITIES AND FLOW DIRECTIONS

PLAN A LITTLE GOOSE FISH LADDER

12-IN. HEAD ON PLAN B WEIR 627

DISCHARGE 72.2 CFS

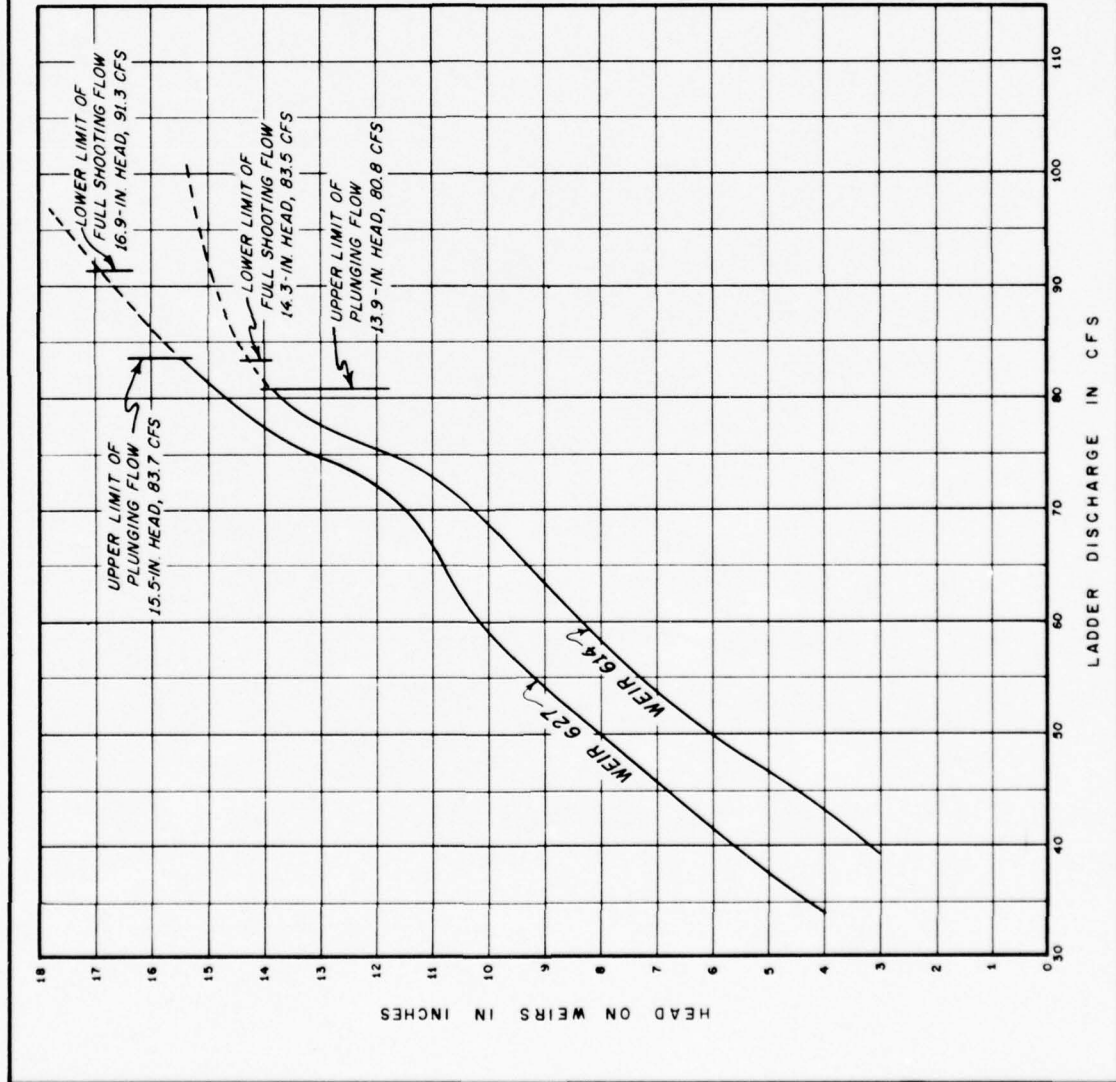

NOTES

1. HEAD DETERMINED FROM WATER-SURFACE ELEVATIONS 5-FT UPSTREAM FROM WEIRS (SEE PLATE 2 FOR WEIR LOCATION).
2. DATA INCONSISTANT ABOVE UPPER LIMIT OF PLUNGING FLOW.

DISCHARGE CURVES  
 LITTLE GOOSE FISH LADDER  
 PLAN B WEIR 627, PLAN A WEIR 614  
 (18-BY-18-IN. ORIFICES IN ALL WEIRS)

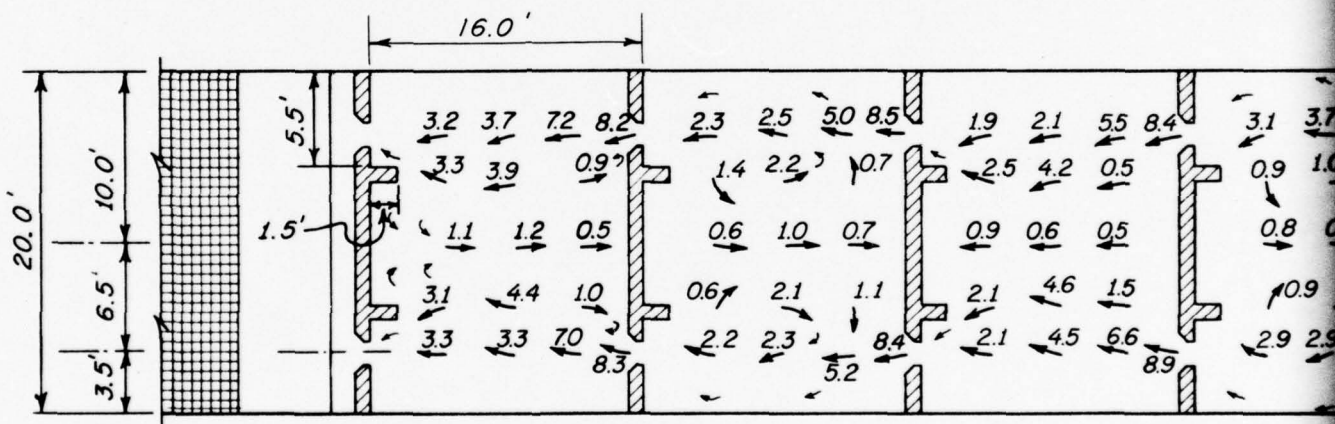
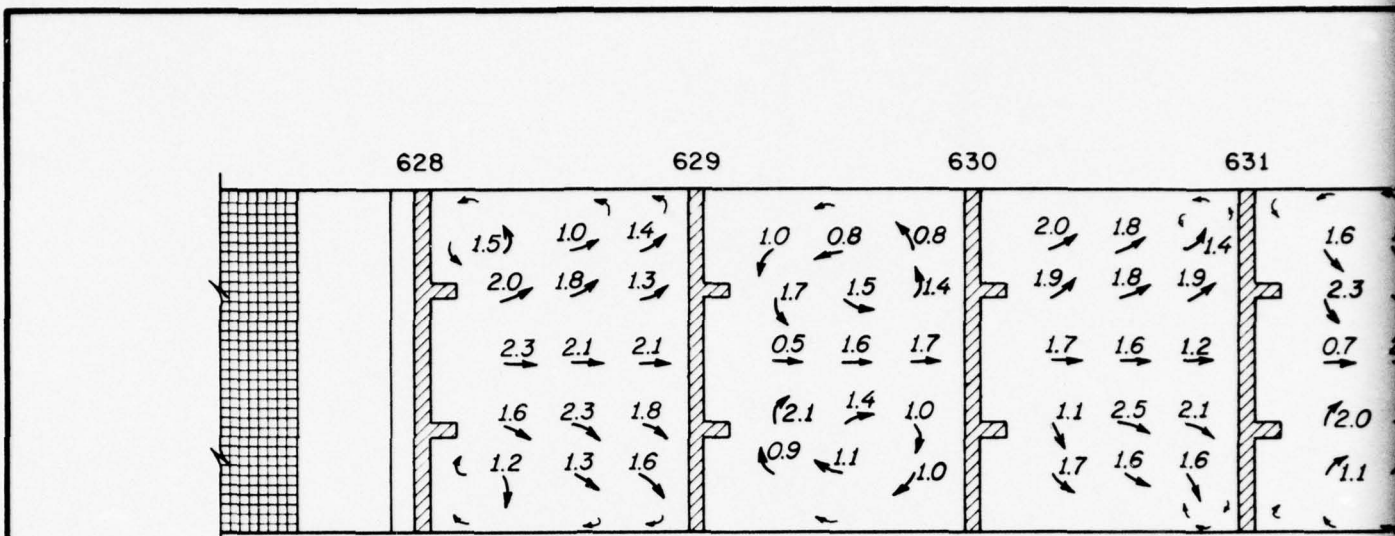

CENTER L

NOTES

1. VELOCITIES (FPS) MEASURED IN HORIZONTAL PLANE.
2. HEAD ON WEIR 627, 12 IN.
3. 18 - BY 37 - IN. ORIFICES IN BULKHEADS 628 TO 636.
4. 18 - BY 40 - IN. ORIFICE IN BULKHEAD 637.

21

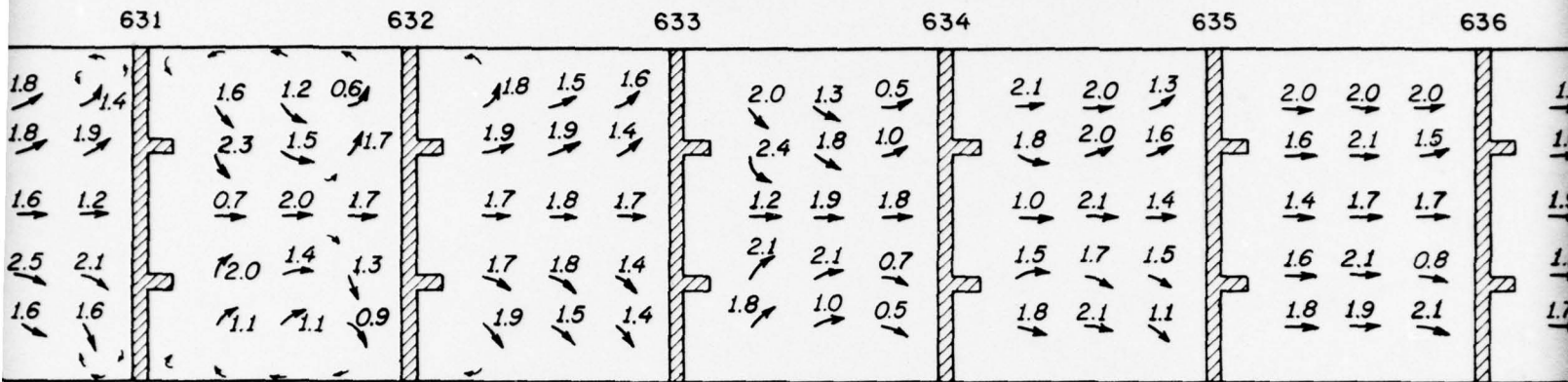

1 FT BELOW WATER SURFACE

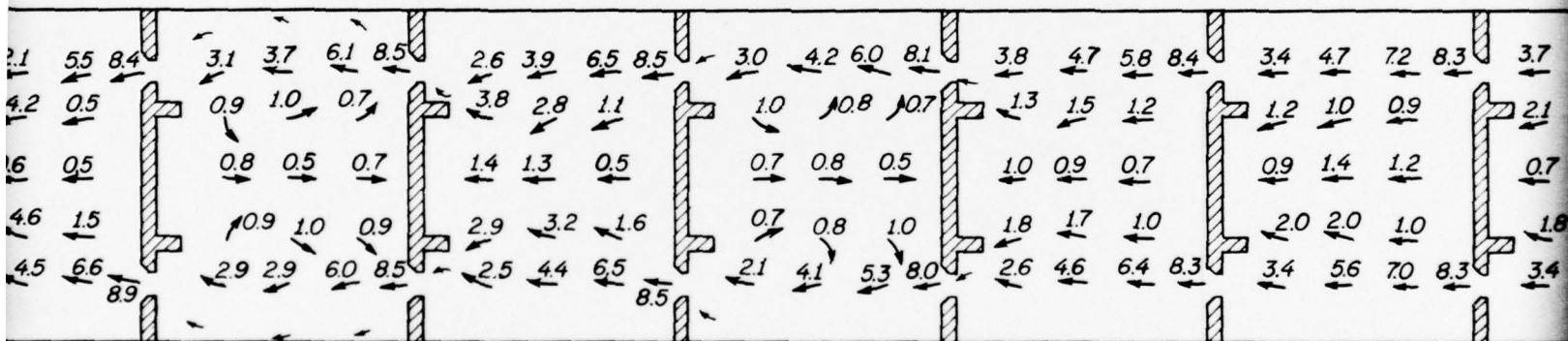

CENTER LINE OF ORIFICES IN UPSTREAM BULKHEAD

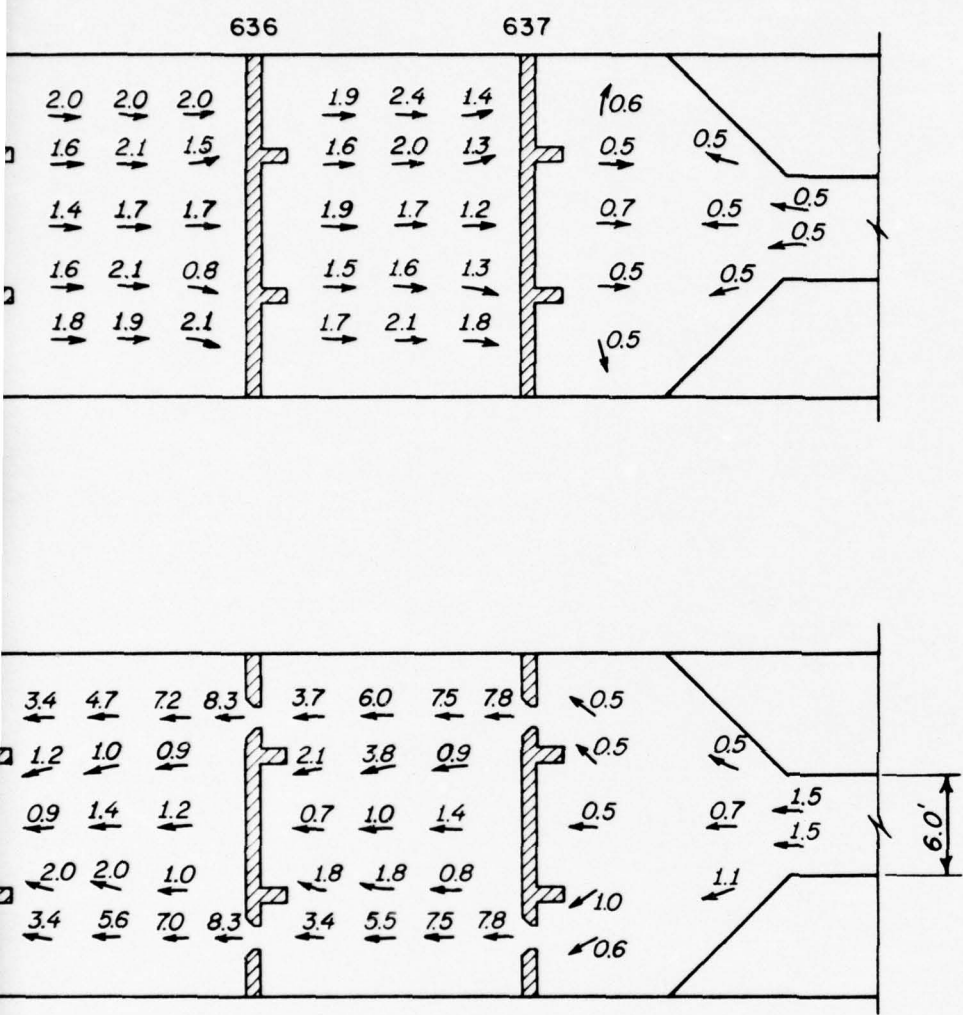

VELOCITIES AND FLOW DIRECTIONS  
PLAN C CONTROL SECTION  
LITTLE GOOSE FISH LADDER  
FOREBAY ELEV 638, DISCHARGE 56.6 CFS

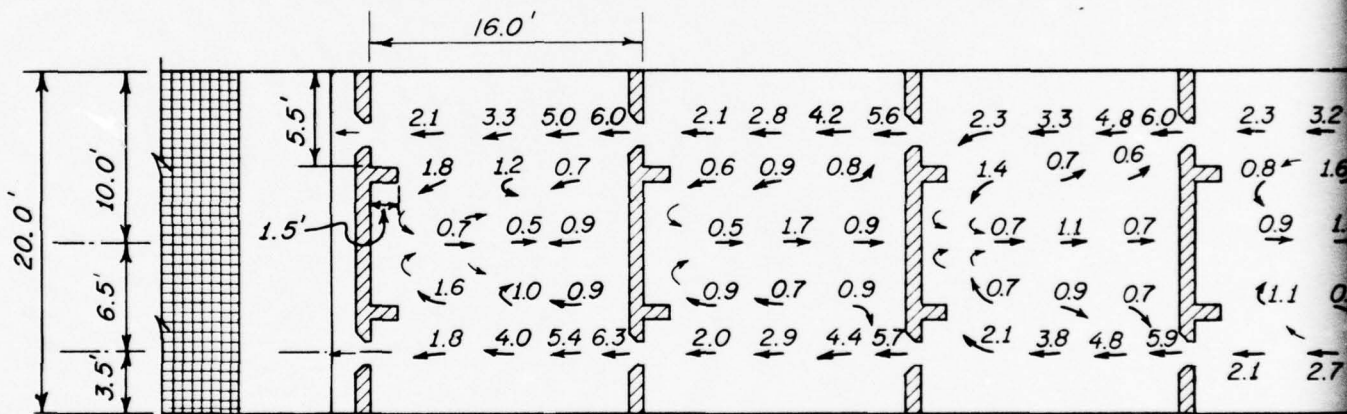
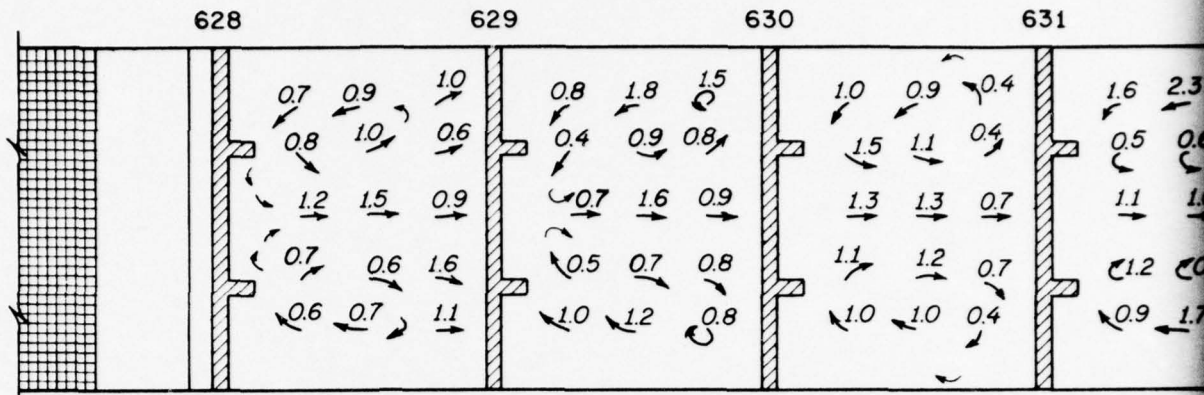

CENTER LINE

NOTES

1. VELOCITIES (FPS) MEASURED IN HORIZONTAL PLANE.
2. HEAD ON WEIR 627, 12 IN.
3. 18 - BY 37 - IN. ORIFICES IN BULKHEADS 628 TO 636.
4. 18 - BY 40 - IN. ORIFICE IN BULKHEAD 637.

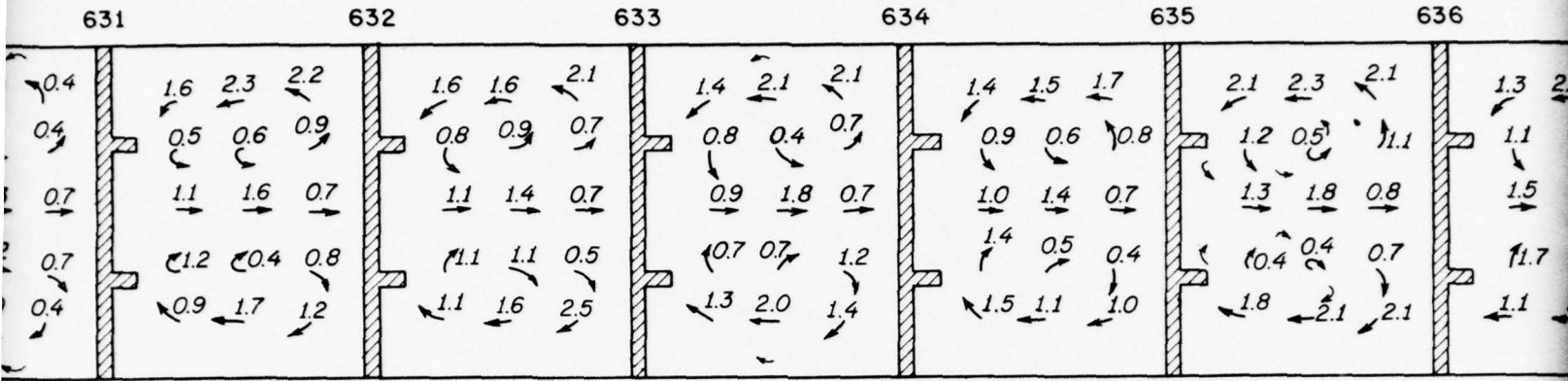

1 FT BELOW WATER SURFACE

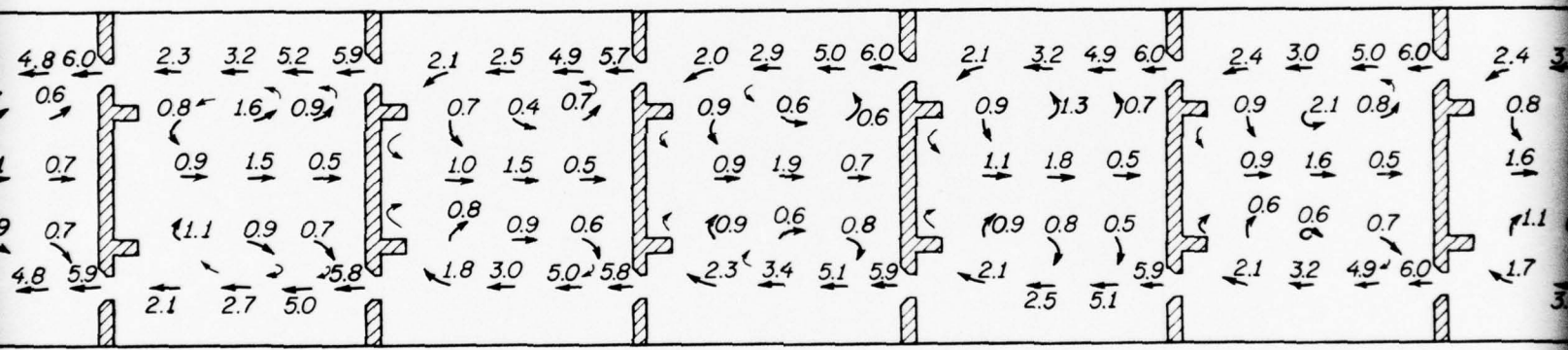

CENTER LINE OF ORIFICES IN UPSTREAM BULKHEAD

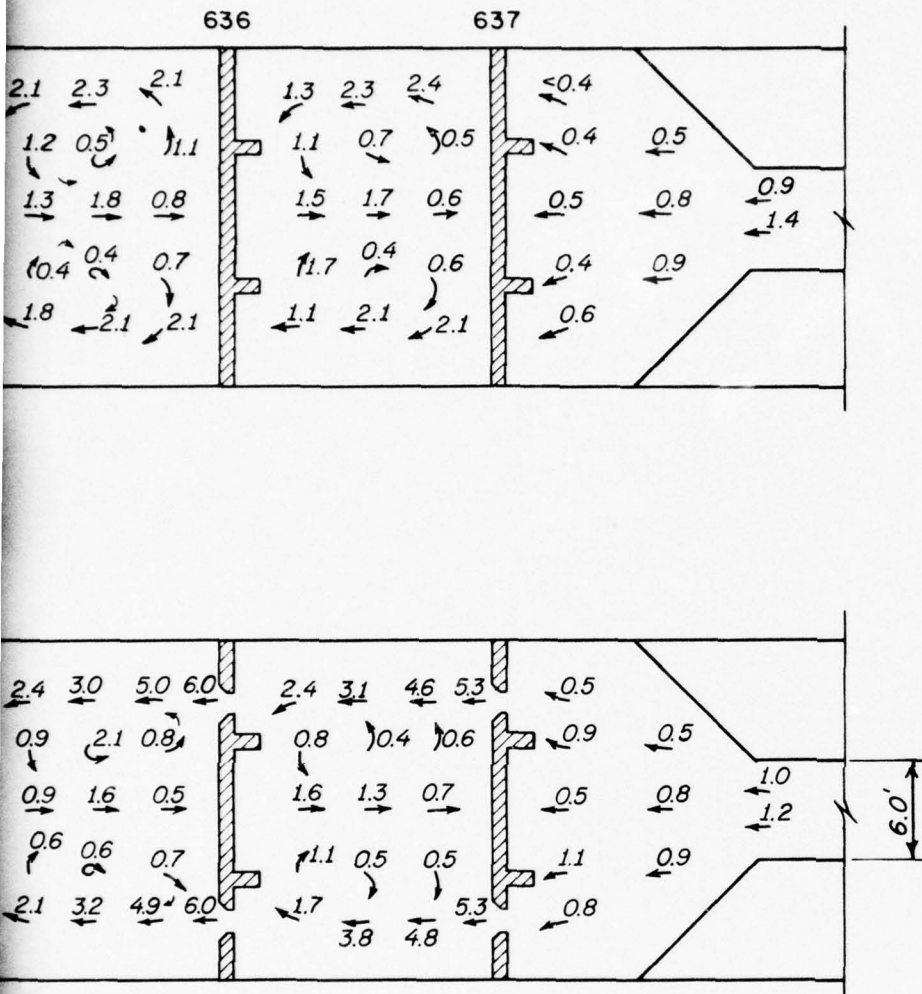

VELOCITIES AND FLOW DIRECTIONS

PLAN C CONTROL SECTION  
LITTLE GOOSE FISH LADDER

FOREBAY ELEV 633, DISCHARGE 40.0 CFS

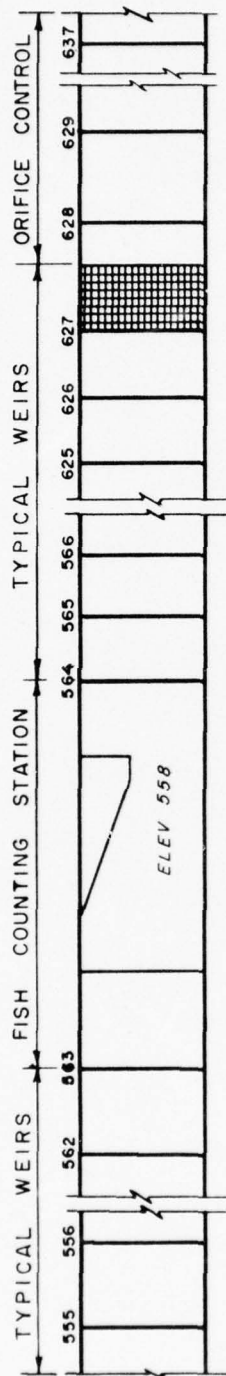

**PLAN**

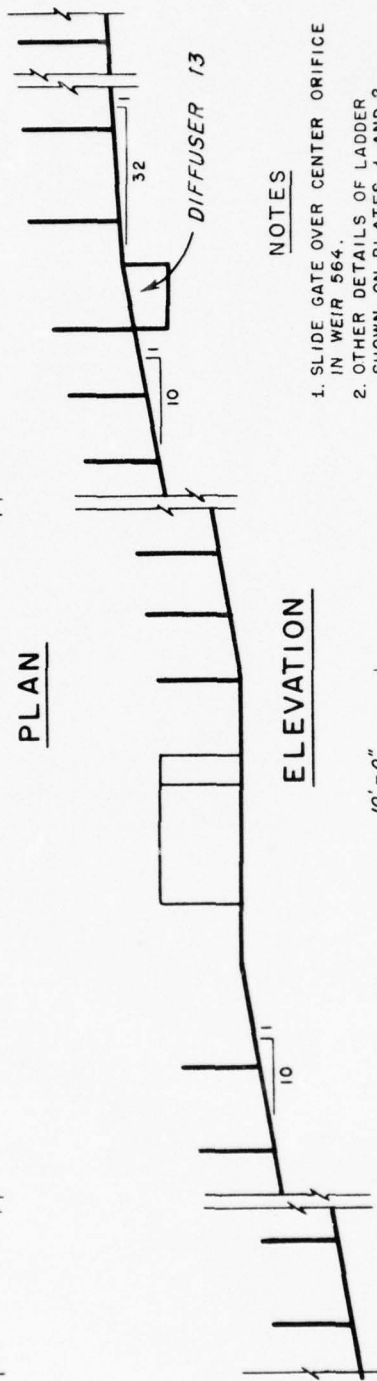

**ELEVATION**

**NOTES**

1. SLIDE GATE OVER CENTER ORIFICE IN WEIR 564.
2. OTHER DETAILS OF LADDER SHOWN ON PLATES 1 AND 2.

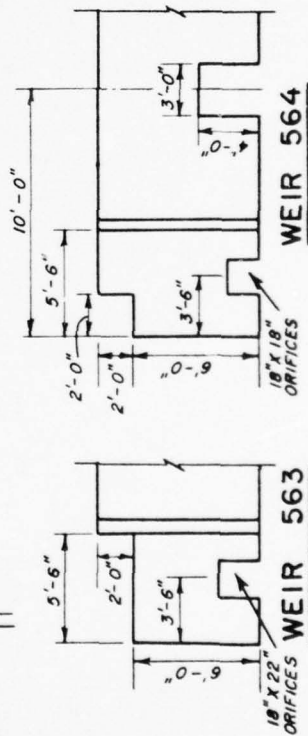

**MODEL LAYOUT  
COUNTING STATION**

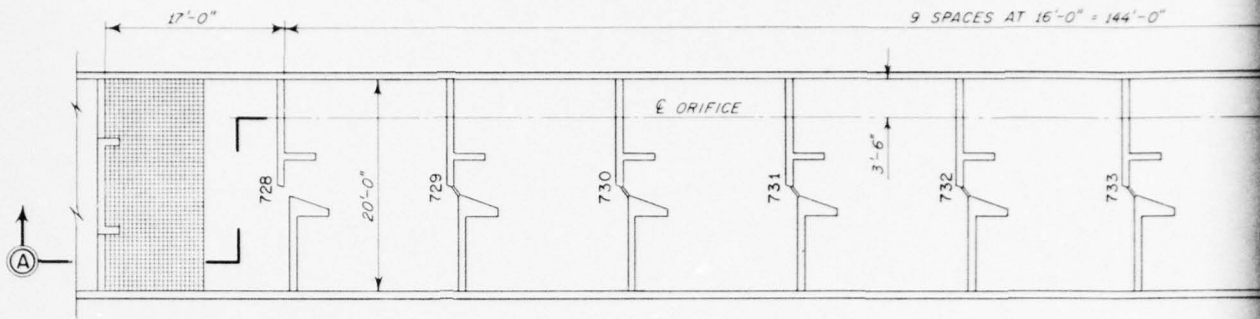

PLAN

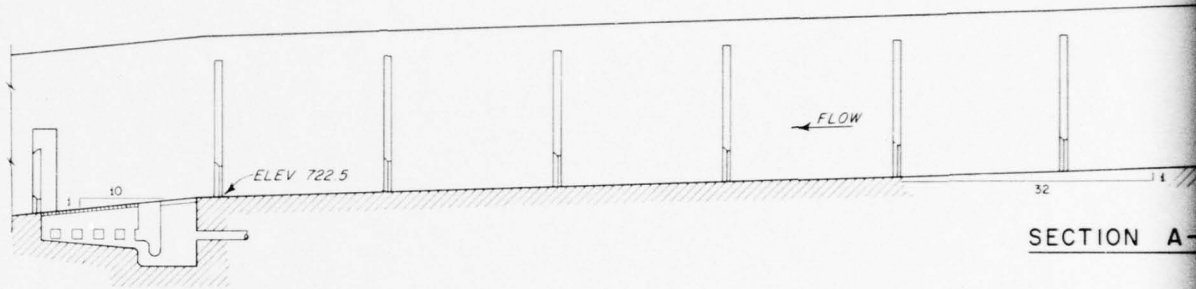

SECTION A-A

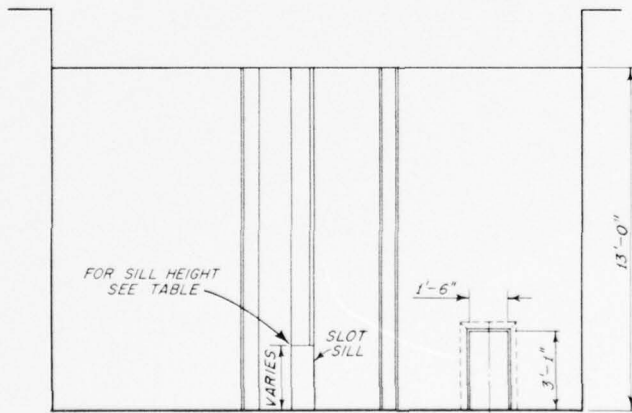

ELEVATION

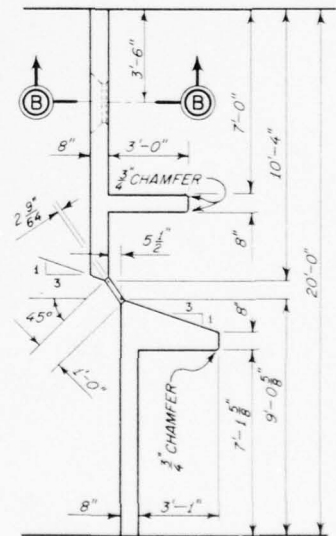

PLAN

BULKHEAD DETAILS



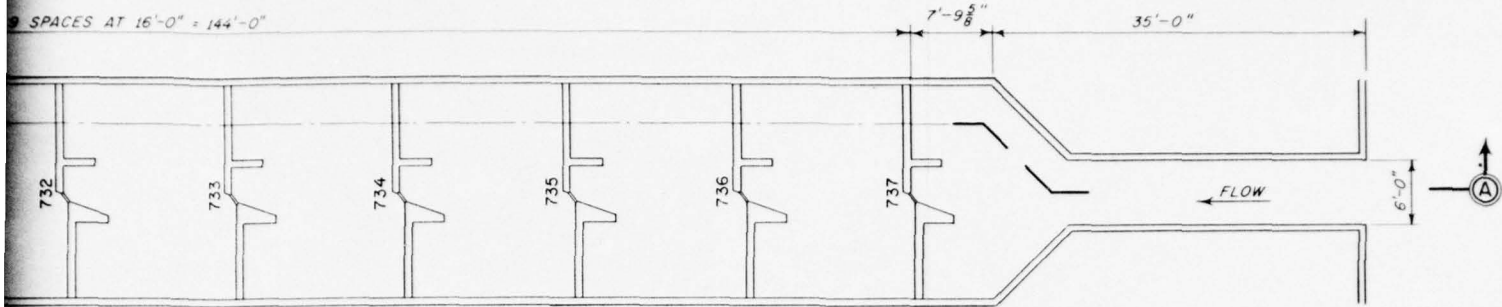

PLAN

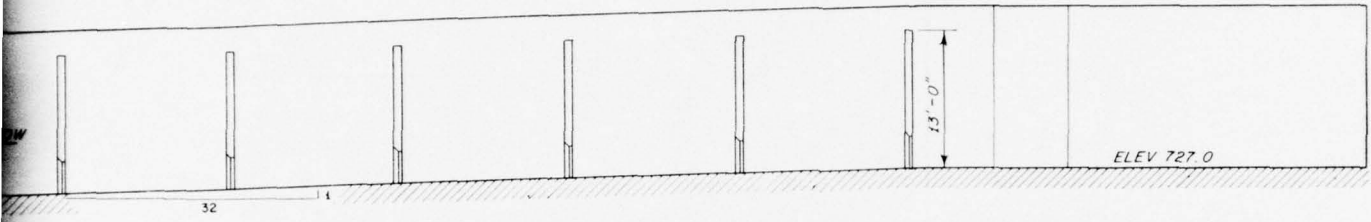

SECTION A-A

BULKHEAD NO.	SILL HEIGHT
728	0
729	0'-6"
730	1'-0"
731	1'-6"
732	2'-0"
733	2'-6"
734	3'-0"
735	3'-6"
736	4'-0"
737	4'-6"

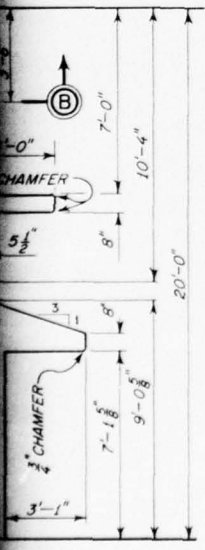

PLAN

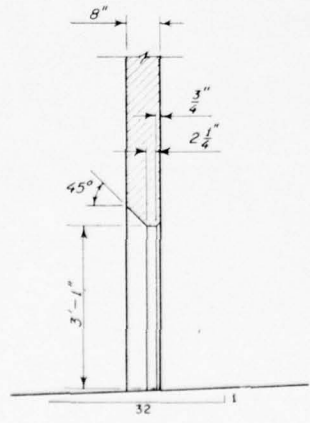

SECTION B-B

MODEL LAYOUT  
 PLAN A CONTROL SECTION  
 LOWER GRANITE FISH LADDER

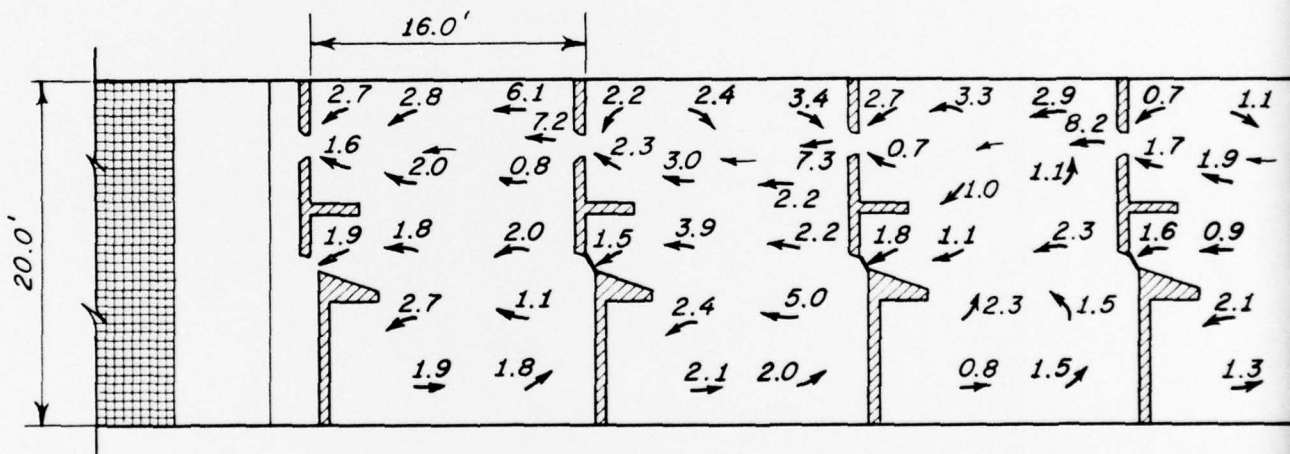
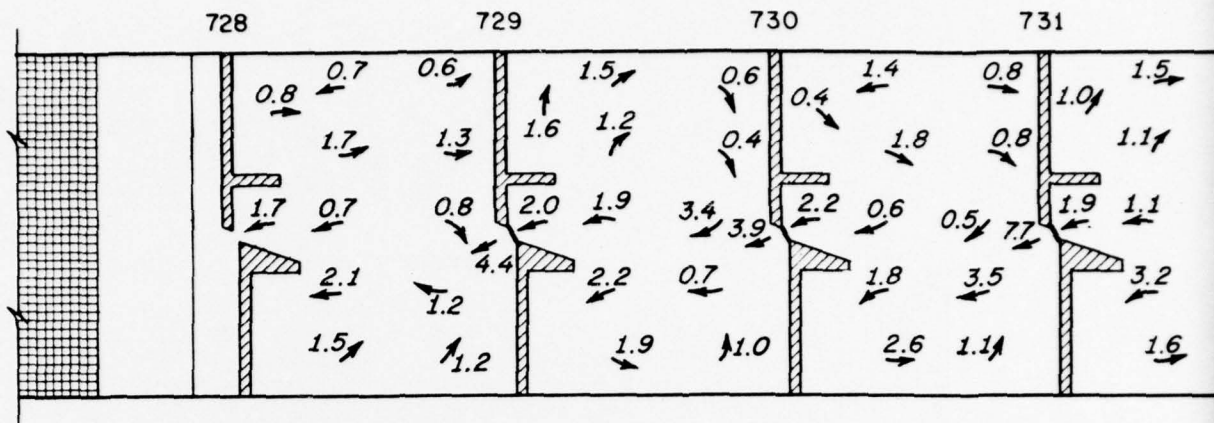

**NOTES**

1. VELOCITIES (FPS) MEASURED IN HORIZONTAL PLANE.
2. HEAD ON WEIR 727, 12 IN.
3. BULKHEAD ORIFICES 18 BY 37 IN.
4. DETAILS OF BULKHEADS AND CONTROL SECTION SHOWN ON PLATE 9.

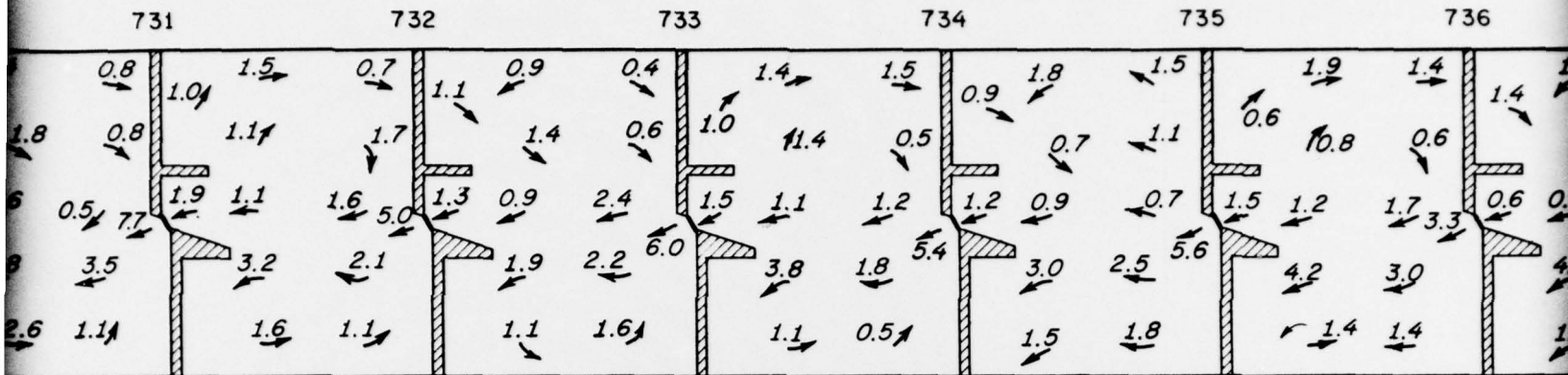

1 FT BELOW WATER SURFACE

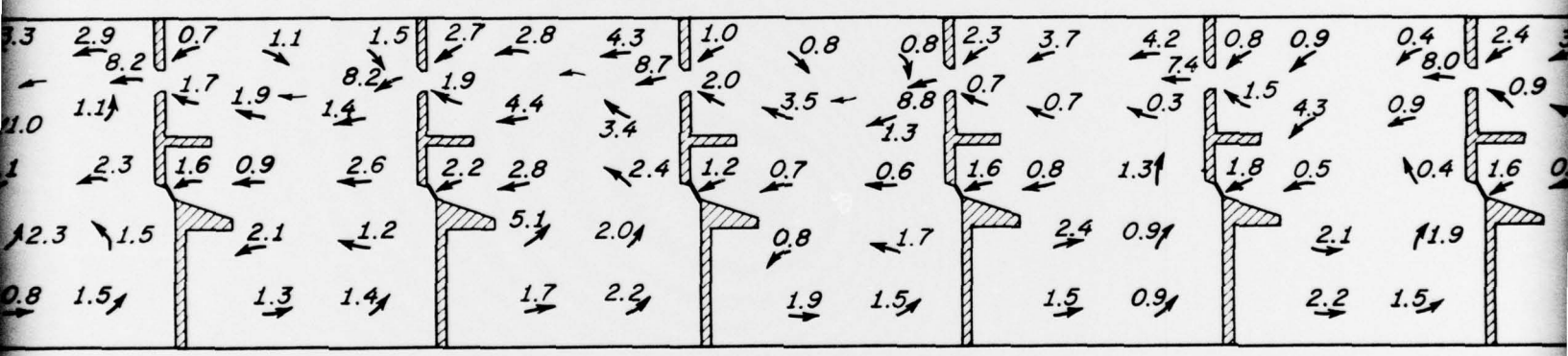

CENTER LINE OF ORIFICES

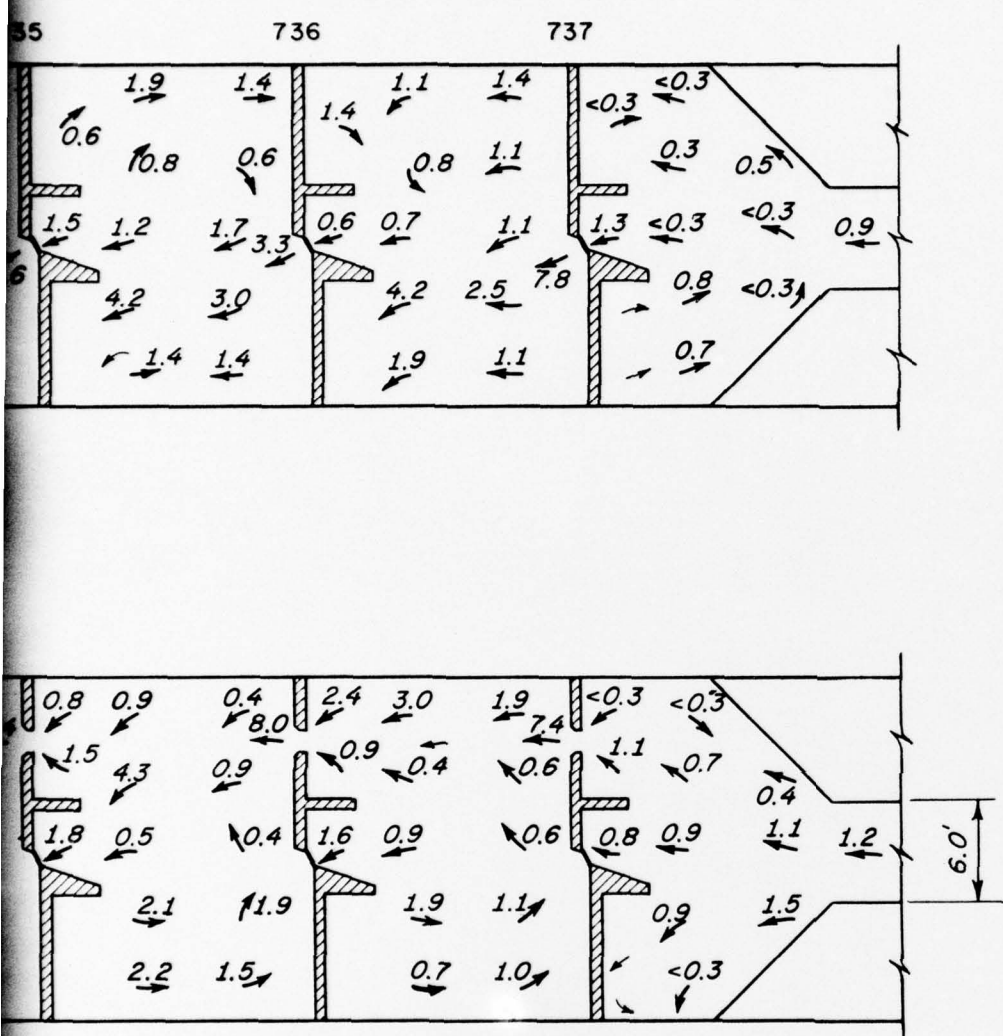

VELOCITIES AND FLOW DIRECTIONS

PLAN A CONTROL SECTION  
LOWER GRANITE FISH LADDER

FOREBAY ELEV 738, DISCHARGE 63.8 CFS

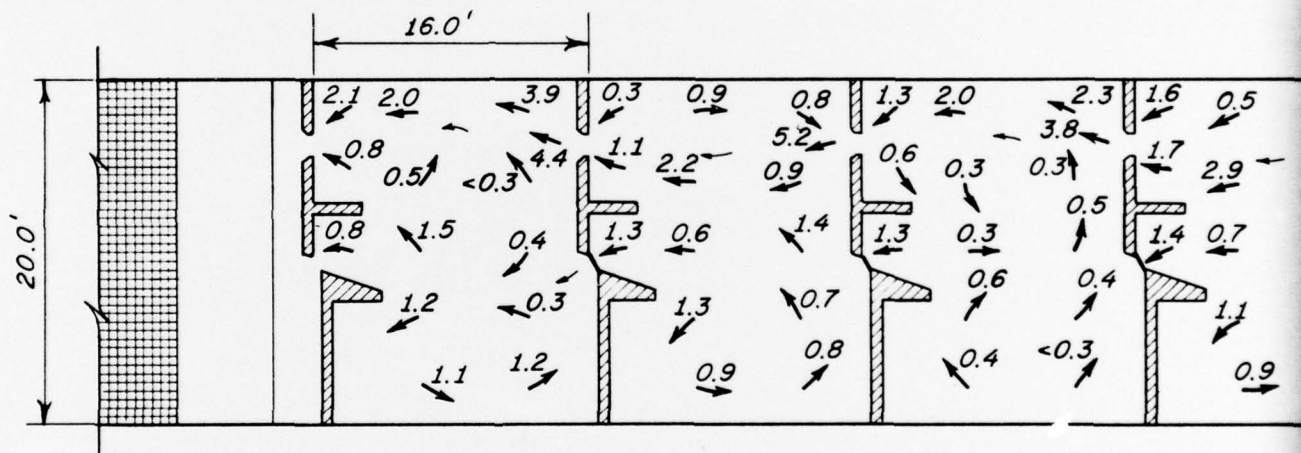
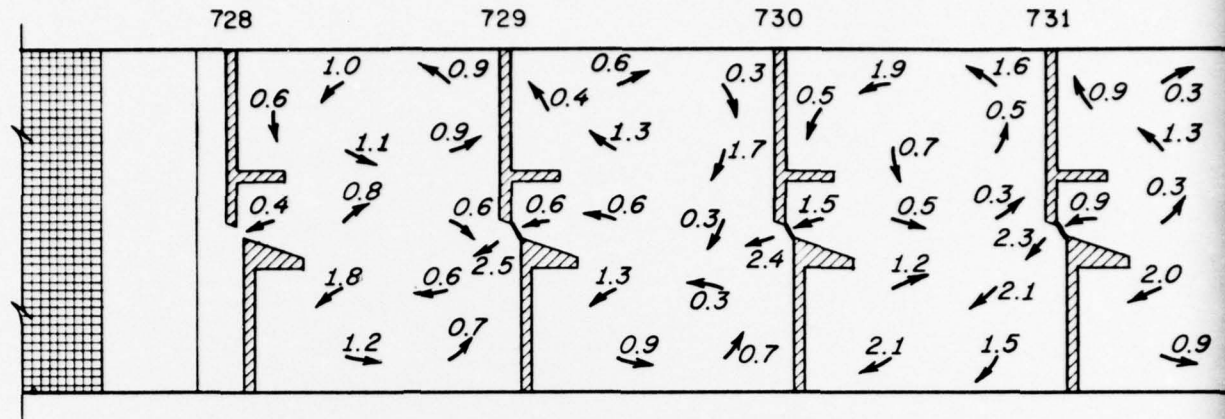

### NOTES

1. VELOCITIES (FPS) MEASURED IN HORIZONTAL PLANE.
2. HEAD ON WEIR 727, 12 IN.
3. BULKHEAD ORIFICES 18 BY 37 IN.
4. DETAILS OF BULKHEADS AND CONTROL SECTION SHOWN ON PLATE 9.

21

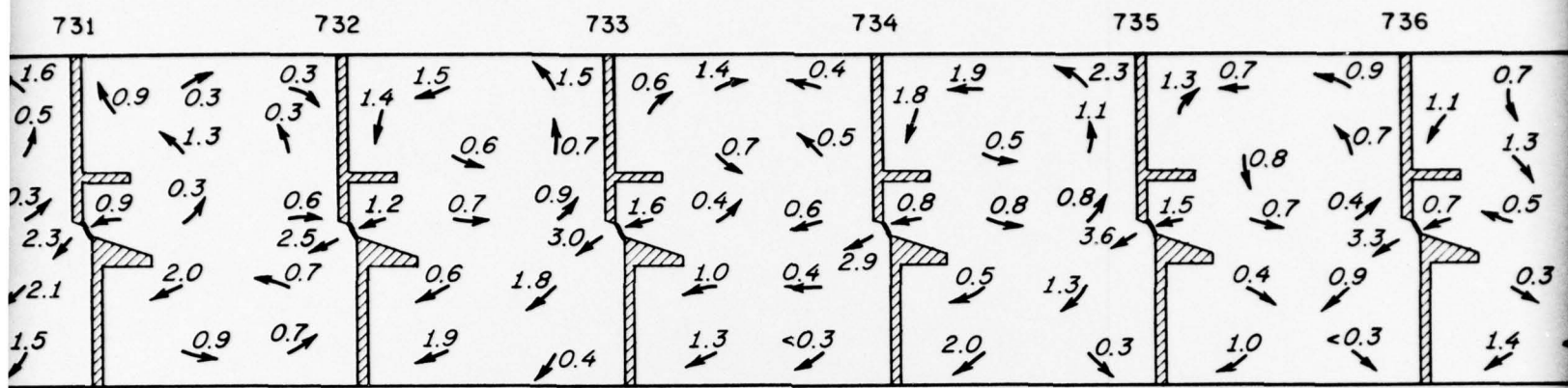

1 FT BELOW WATER SURFACE

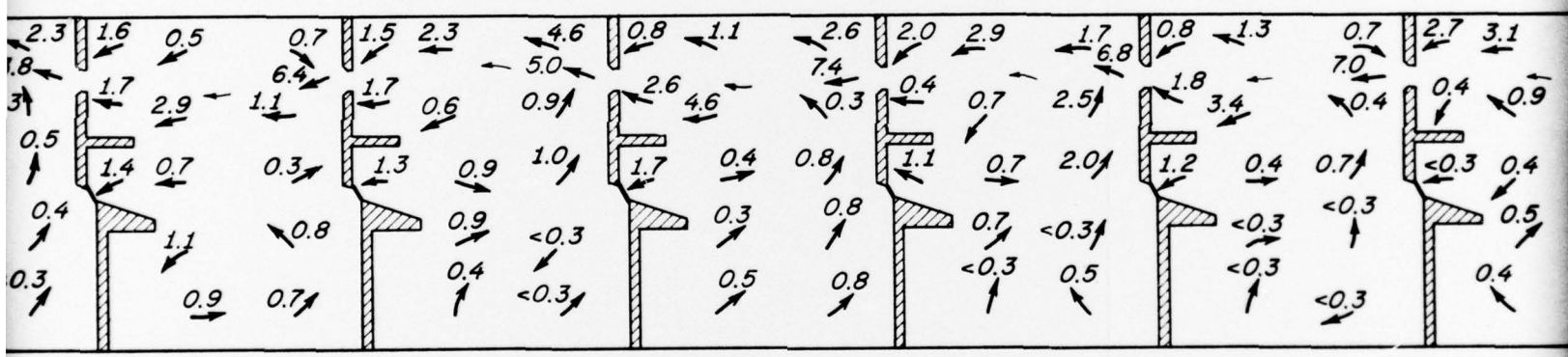

CENTER LINE OF ORIFICES

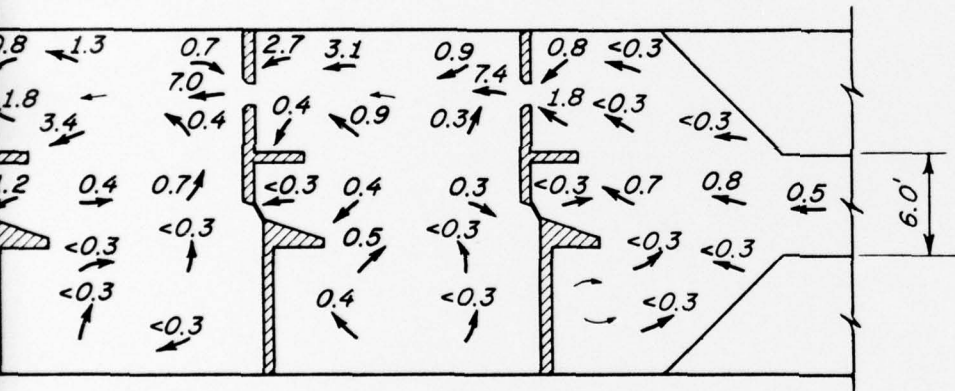
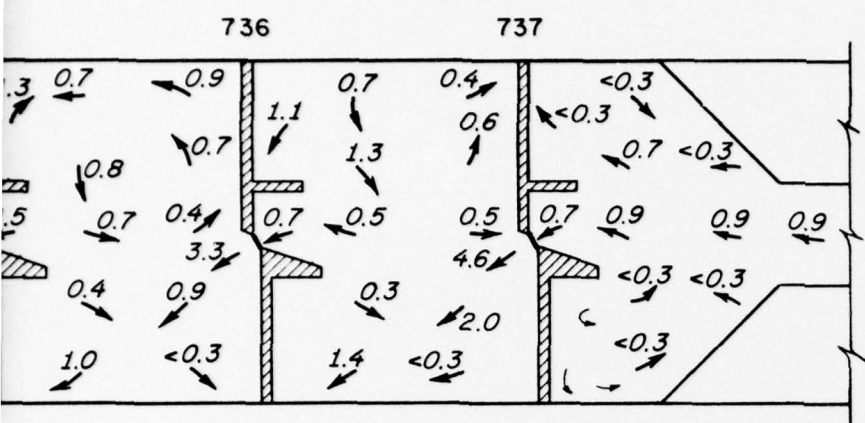

VELOCITIES AND FLOW DIRECTIONS  
PLAN A CONTROL SECTION  
LOWER GRANITE FISH LADDER  
FOREBAY ELEV 733, DISCHARGE 30.8 CFS

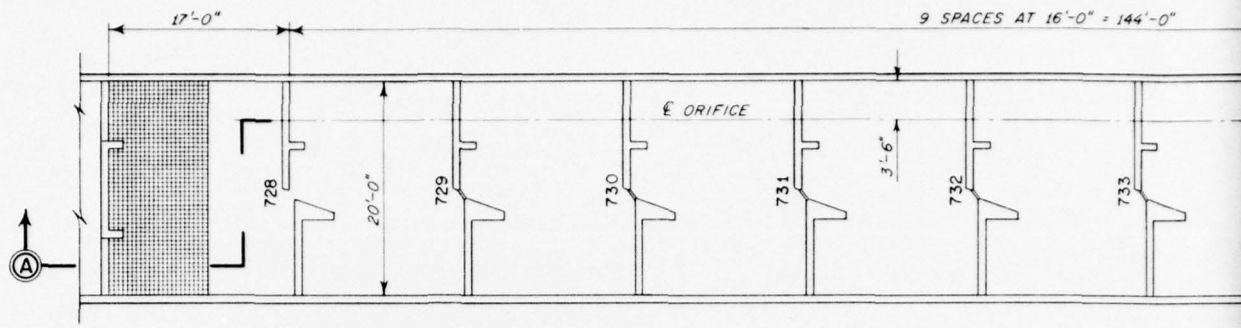

PLAN

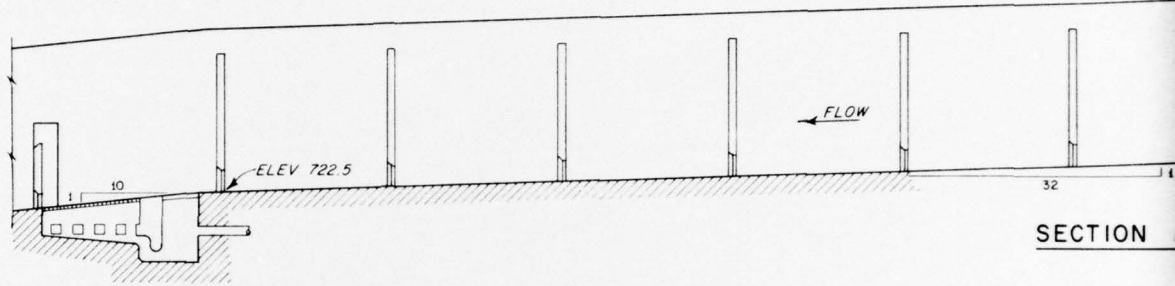

SECTION A

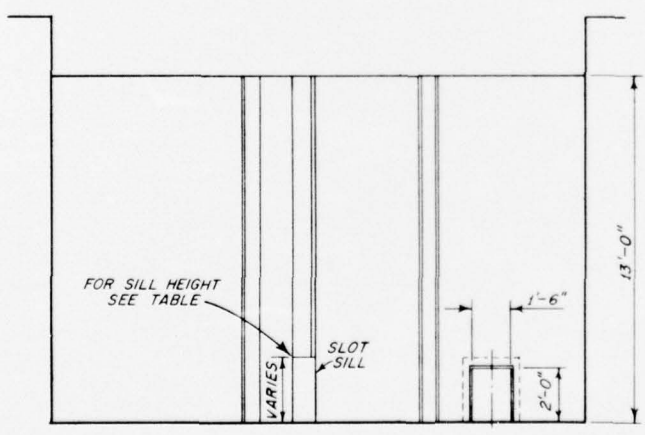

ELEVATION

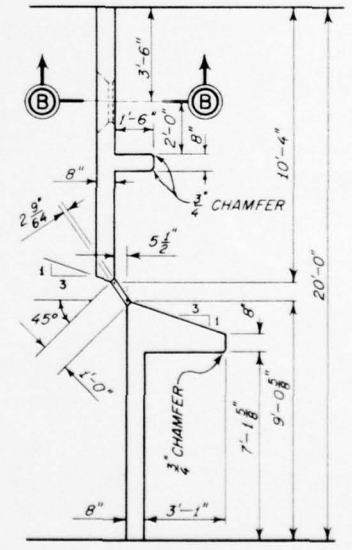

PLAN

BULKHEAD DETAILS

2

PACES AT 16'-0" = 144'-0"

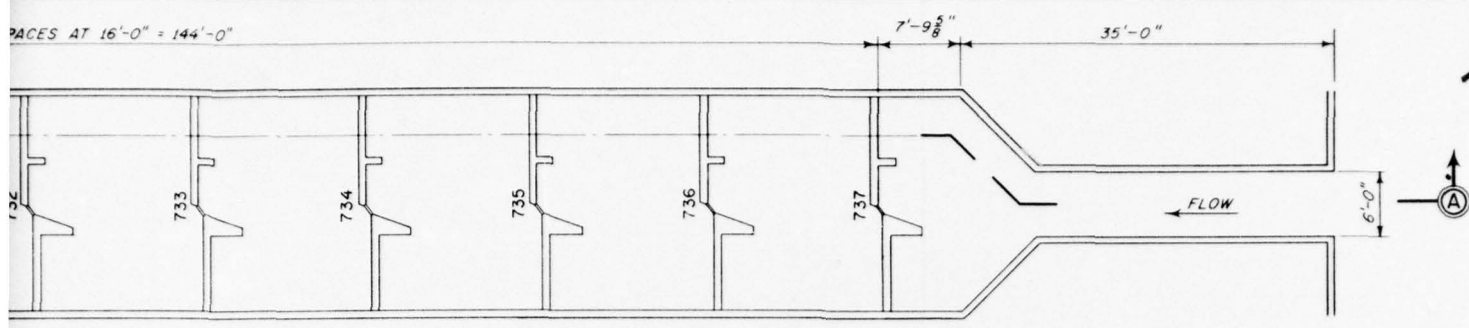

PLAN

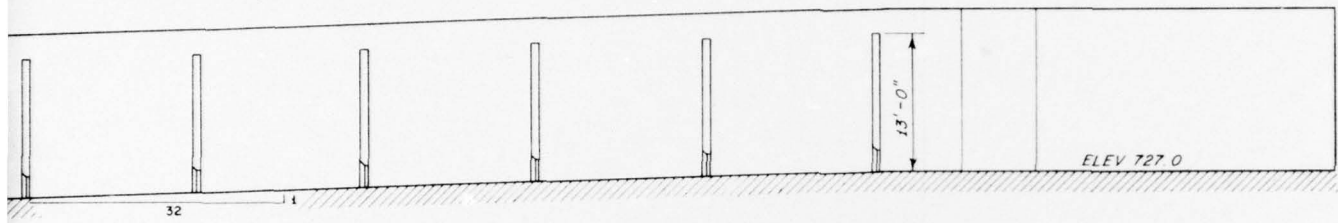

SECTION A-A

BULKHEAD NO.	SILL HEIGHT
728	0
729	0'-6"
730	1'-0"
731	1'-6"
732	2'-0"
733	2'-6"
734	3'-0"
735	3'-6"
736	4'-0"
737	4'-0"

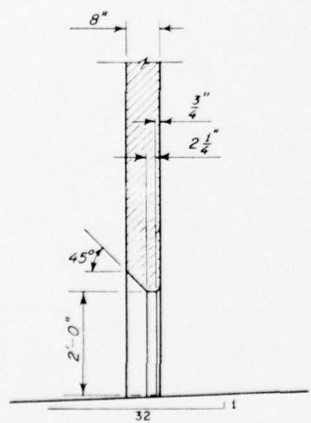
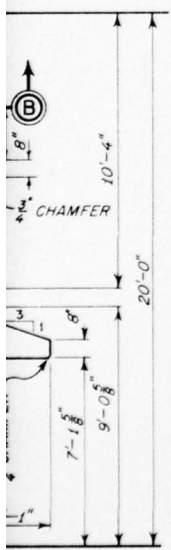

SECTION B-B

MODEL LAYOUT  
 PLAN C-5 CONTROL SECTION  
 LOWER GRANITE FISH LADDER

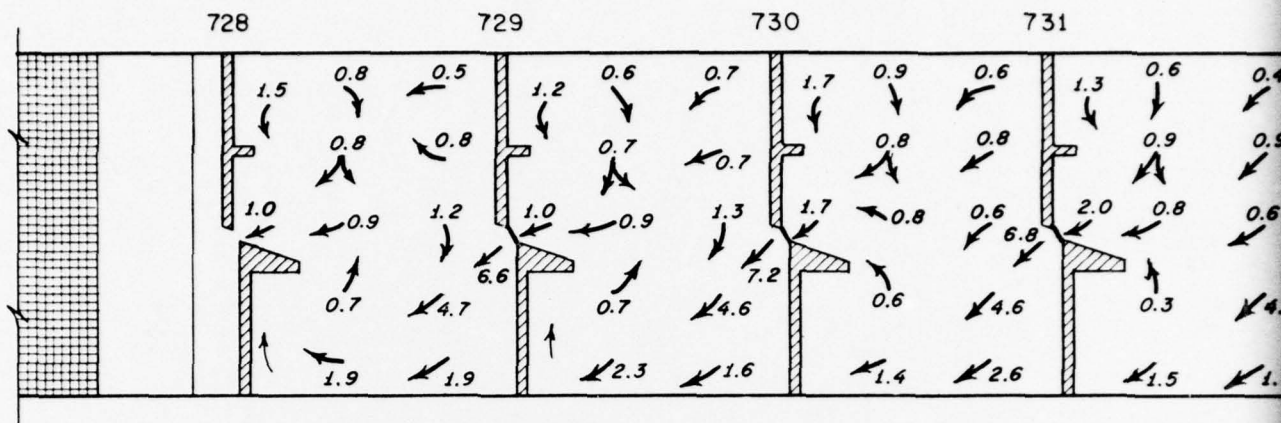

1 F

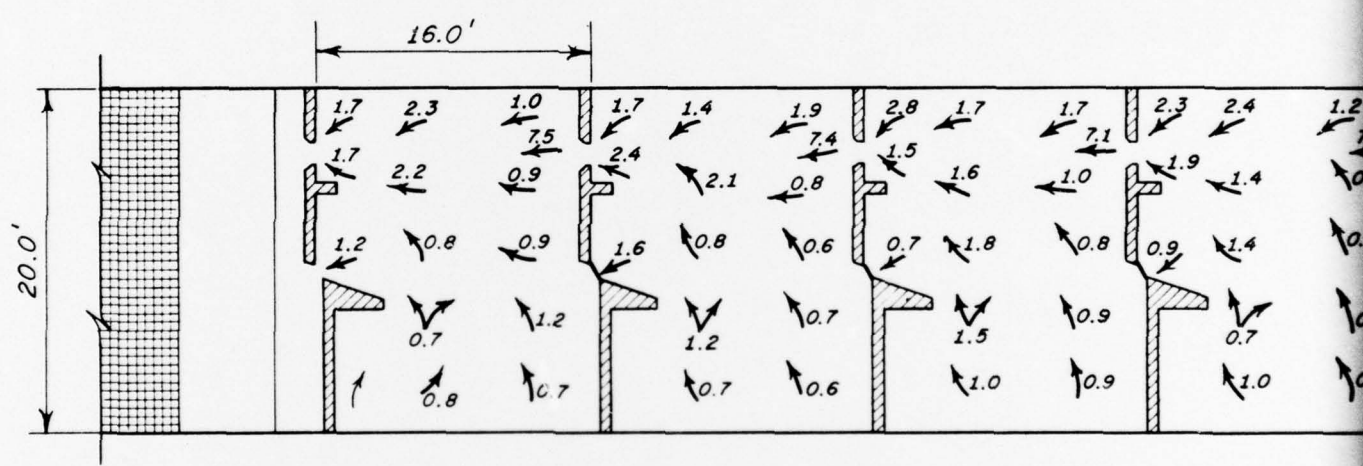

NOTES

1. VELOCITIES (FPS) MEASURED IN HORIZONTAL PLANE.
2. HEAD ON WEIR 727, 12 IN.
3. BULKHEAD ORIFICES 18 BY 24 IN.
4. DETAILS OF BULKHEADS AND CONTROL SECTION SHOWN ON PLATE 12.

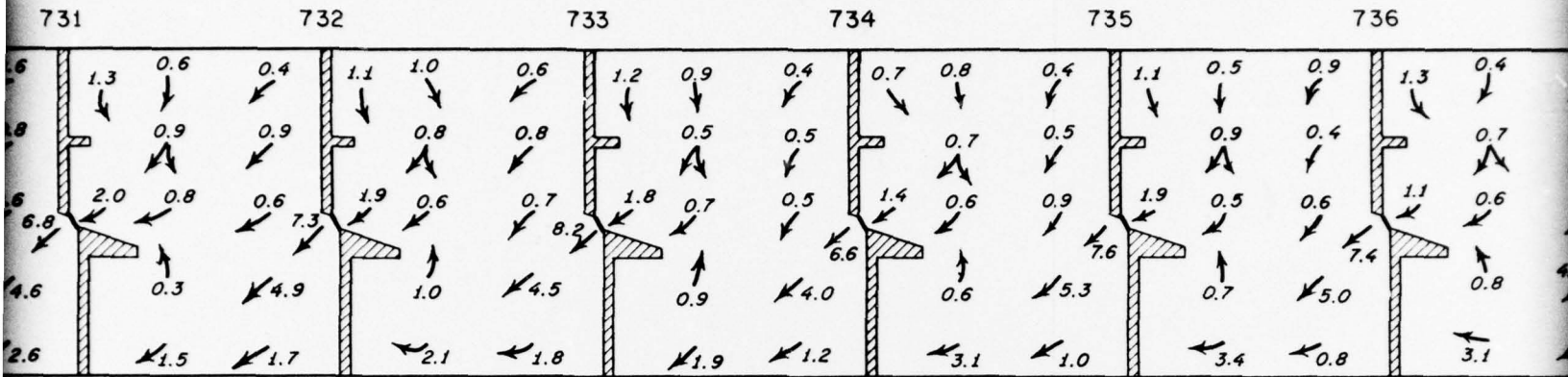

1 FT BELOW WATER SURFACE

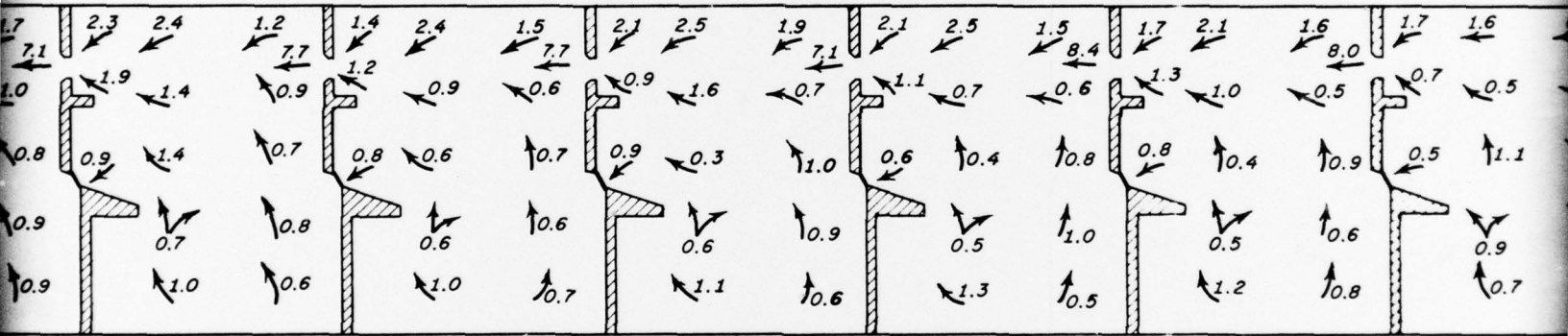

CENTER LINE OF ORIFICES

VEL  
FOR

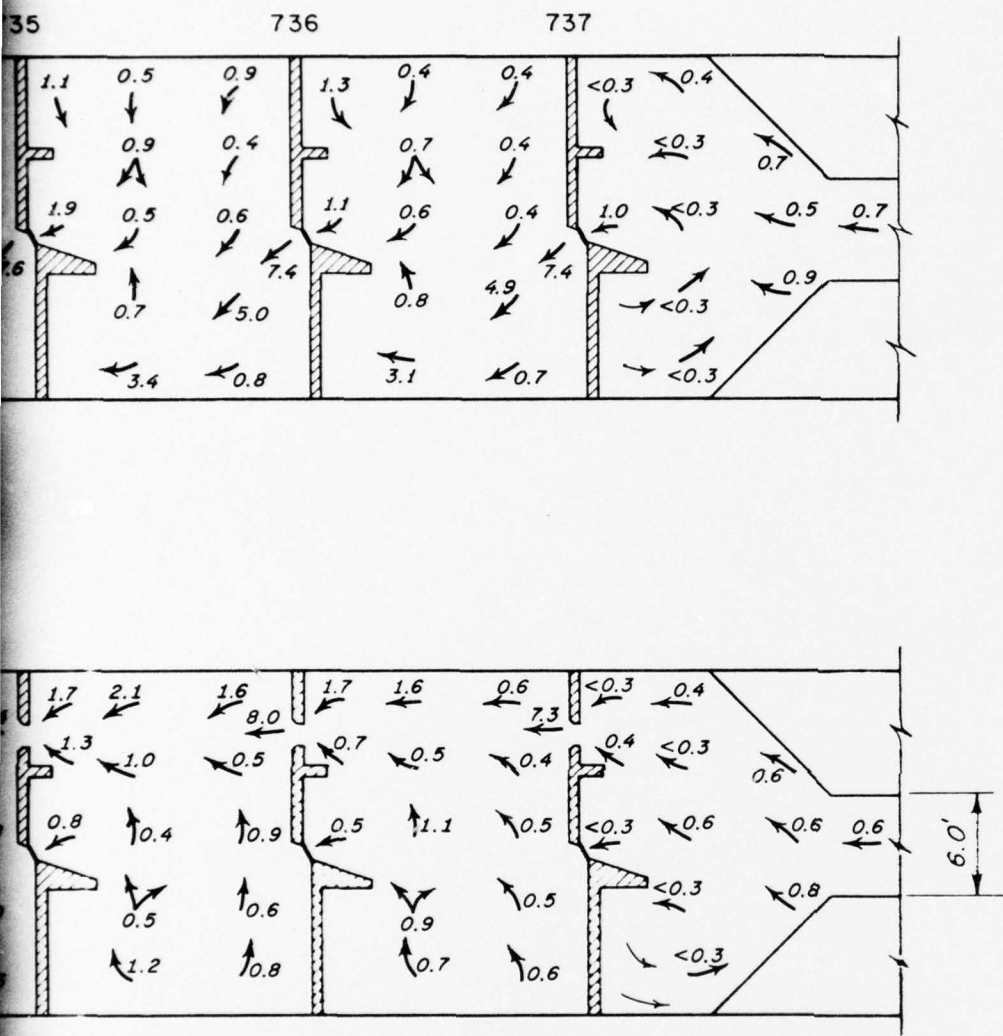

VELOCITIES AND FLOW DIRECTIONS  
PLAN C-5 CONTROL SECTION  
LOWER GRANITE FISH LADDER  
FOREBAY ELEV 738, DISCHARGE 57.5 CFS

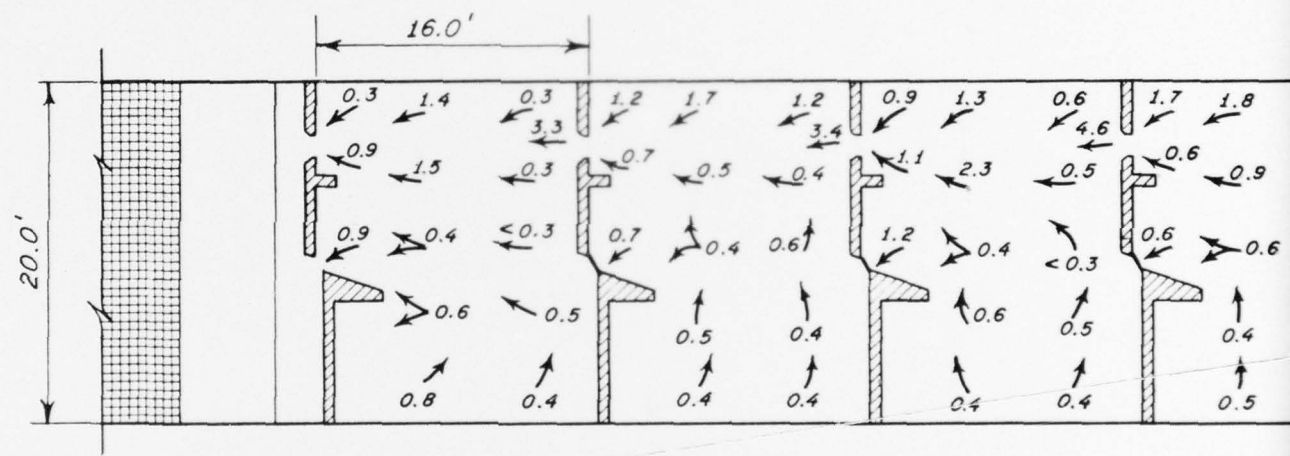
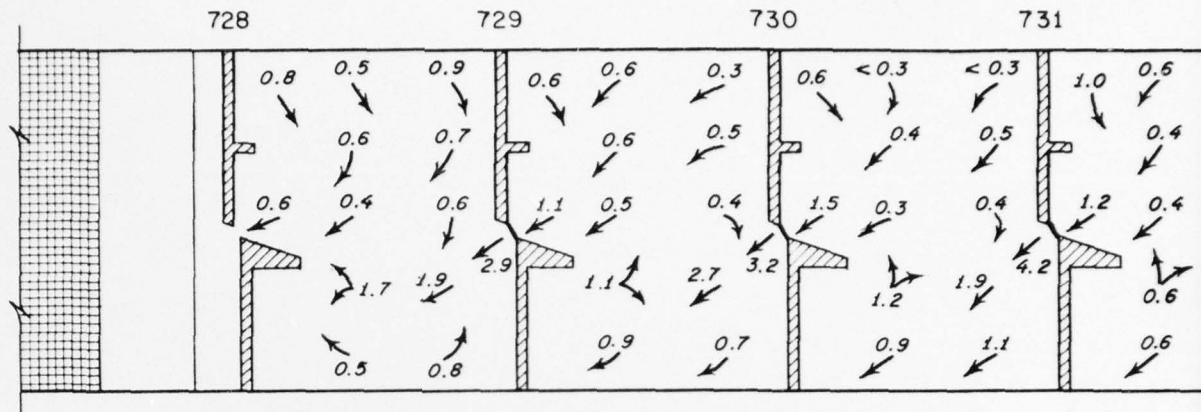

**NOTES**

1. VELOCITIES (FPS) MEASURED IN HORIZONTAL PLANE.
2. HEAD ON WEIR 727, 12 IN.
3. BULKHEAD ORIFICES 18 BY 24 IN.
4. DETAILS OF BULKHEADS AND CONTROL SECTION SHOWN ON PLATE 12.



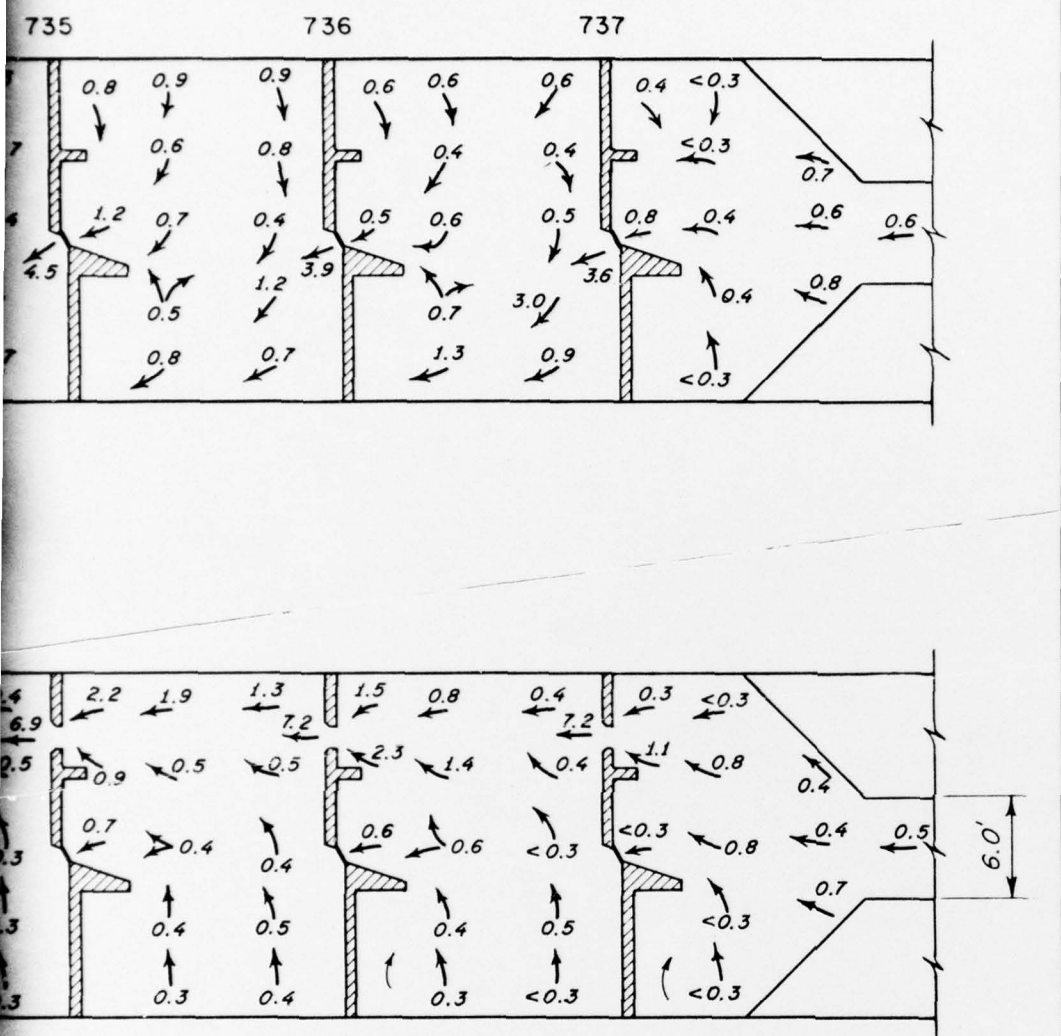

VELOCITIES AND FLOW DIRECTIONS  
PLAN C-5 CONTROL SECTION  
LOWER GRANITE FISH LADDER  
FOREBAY ELEV 733, DISCHARGE 24.4 CFS